

SERVICE MANUAL



CI 9060/9120

**SIX CHANNEL AMPLIFIER
TWELVE CHANNEL AMPLIFIER**

CI 9060/9120

**SIX CHANNEL AMPLIFIER
TWELVE CHANNEL AMPLIFIER**

PRODUCT SAFETY SERVICING GUIDELINES

CAUTION : DO NOT ATTEMPT TO MODIFY THIS PRODUCT IN ANY WAY. NEVER PERFORM CUSTOMIZED INSTALLATIONS WITHOUT MANUFACTURER'S APPROVAL. UNAUTHORIZED MODIFICATIONS WILL NOT ONLY VOID THE WARRANTY, BUT MAY LEAD TO YOUR BEING LIABLE FOR ANY RESULTING PROPERTY DAMAGE OR USER INJURY.

SERVICE WORK SHOULD BE PERFORMED ONLY AFTER YOU ARE THOROUGHLY FAMILIAR WITH ALL OF THE FOLLOWING SAFETY CHECKS AND SERVICING GUIDELINES. TO DO OTHERWISE, INCREASES THE RISK OF POTENTIAL HAZARDS AND INJURY TO THE USER.

WHILE SERVICING, USE AN ISOLATION TRANSFORMER FOR PROTECTION FROM AC LINE SHOCK.

SAFETY CHECKS

AFTER THE ORIGINAL SERVICE PROBLEM HAS BEEN CORRECTED. A CHECK SHOULD BE MADE OF THE FOLLOWING.

SUBJECT : FIRE & SHOCK HAZARD

1. BE SURE THAT ALL COMPONENTS ARE POSITIONED IN SUCH A WAY AS TO AVOID POSSIBILITY OF ADJACENT COMPONENT SHORTS. THIS IS ESPECIALLY IMPORTANT ON THOSE MODULES WHICH ARE TRANSPORTED TO AND FROM THE REPAIR SHOP.
2. NEVER RELEASE A REPAIR UNLESS ALL PROTECTIVE DEVICES SUCH AS INSULATORS, BARRIERS, COVERS, SHIELDS, STRAIN RELIEFS, POWER SUPPLY CORDS, AND OTHER HARDWARE HAVE BEEN REINSTALLED PER ORIGINAL DESIGN. BE SURE THAT THE SAFETY PURPOSE OF THE POLARIZED LINE PLUG HAS NOT BEEN DEFEATED.
3. SOLDERING MUST BE INSPECTED TO DISCOVER POSSIBLE COLD SOLDER JOINTS, SOLDER SPLASHES OR SHARP SOLDER POINTS. BE CERTAIN TO REMOVE ALL LOOSE FOREIGN PARTICLES.
4. CHECK FOR PHYSICAL EVIDENCE OF DAMAGE OR DETERIORATION TO PARTS AND COMPONENTS. FOR FRAYED LEADS, DAMAGED INSULATION (INCLUDING AC CORD). AND REPLACE IF NECESSARY FOLLOW ORIGINAL LAYOUT, LEAD LENGTH AND DRESS.
5. NO LEAD OR COMPONENT SHOULD TOUCH A RECEIVING TUBE OR A RESISTOR RATED AT 1 WATT OR MORE. LEAD TENSION AROUND PROTRUDING METAL SURFACES MUST BE AVOIDED.
6. ALL CRITICAL COMPONENTS SUCH AS FUSES, FLAMEPROOF RESISTORS, CAPACITORS, ETC. MUST BE REPLACED WITH EXACT FACTORY TYPES, DO NOT USE REPLACEMENT COMPONENTS OTHER THAN THOSE SPECIFIED OR MAKE UNRECOMMENDED CIRCUIT MODIFICATIONS.
7. AFTER RE-ASSEMBLY OF THE SET ALWAYS PERFORM AN AC LEAKAGE TEST ON ALL EXPOSED METALLIC PARTS OF THE CABINET, (THE CHANNEL SELECTOR KNOB, ANTENNA TERMINALS. HANDLE AND SCREWS) TO BE SURE THE SET IS SAFET TO OPERATE WITHOUT DANGER OF ELECTRICAL SHOCK. DO NOT USE A LINE ISOLATION TRANSFORMER DURING THIS TEST USE AN AC VOLTMETER, HAVING 5000 OHMS PER VOLT OR MORE SENSITIVITY, IN THE FOLLOWING MANNER; CONNECT A 1500 OHM 10 WATT RESISTOR, PARALLELED BY A .15 MFD, 150V AC TYPE CAPACITOR BETWEEN A KNOWN GOOD EARTH GROUND (WATER PIPE, CONDUIT, ETC.) AND THE EXPOSED METALLIC PARTS, ONE AT A TIME.
MEASURE THE AC VOLTAGE ACROSS THE COMBINATION OF 1500 OHM RESISTOR AND .15 MFD CAPACITOR.
REVERSE THE AC PLUG AND REPEAT AC VOLTAGE MEASUREMENTS FOR EACH EXPOSED METALLIC PART.

VOLTAGE MEASURE MUST NOT EXCEED 75 VOLTS R.M.S. THIS CORRESPONDS TO 0.5 MILLIAMPS AC ANY VALUE EXCEEDING THIS LIMIT CONSTITUTES A POTENTIAL SHOCK HAZARD AND MUST BE CORRECTED IMMEDIATELY.

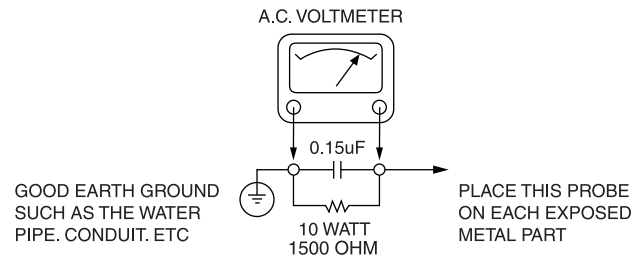

SUBJECT : GRAPHIC SYMBOLS



THE LIGHTNING FLASH WITH ARROWHEAD SYMBOL, WITHIN AN EQUILATERAL TRIANGLE, IS INTENDED TO ALERT THE USER TO THE PRESENCE OF UNINSULATED "DANGEROUS VOLTAGE" WITHIN THE PRODUCT'S ENCLOSURE THAT MAY BE OF SUFFICIENT MAGNITUDE TO CONSTITUTE A RISK OF ELECTRIC SHOCK.



THE EXCLAMATION POINT WITHIN AN EQUILATERAL TRIANGLE IS INTENDED TO ALERT THE USER TO THE PRESENCE OF IMPORTANT OPERATING AND MAINTENANCE (SERVICING) INSTRUCTIONS IN THE LITERATURE ACCOMPANYING THE APPLIANCE.

SUBJECT : TIPS ON PROPER INSTALLATION

1. NEVER INSTALL ANY PRODUCT IN A CLOSED-IN RECESS, CUBBYHOLE OR CLOSELY FITTING SHELF SPACE. OVER OR CLOSE TO HEAT DUCT, OR IN THE PATH OF HEATED AIR FLOW.
2. AVOID CONDITIONS OF HIGH HUMIDITY SUCH AS: OUTDOOR PATIO INSTALLATIONS WHERE DEW IS A FACTOR, NEAR STEAM RADIATORS WHERE STEAM LEAKAGE IS A FACTOR, ETC.
3. AVOID PLACEMENT WHERE DRAPERIES MAY OBSTRUCT REAR VENTING. THE CUSTOMER SHOULD ALSO AVOID THE USE OF DECORATIVE SCARVES OR OTHER COVERINGS WHICH MIGHT OBSTRUCT VENTILATION.
4. WALL AND SHELF MOUNTED INSTALLATIONS USING A COMMERCIAL MOUNTING KIT MUST FOLLOW THE FACTORY APPROVED MOUNTING INSTRUCTIONS A PRODUCT MOUNTED TO A SHELF OR PLATFORM MUST RETAIN ITS ORIGINAL FEET (OR THE EQUIVALENT THICKNESS IN SPACERS) TO PROVIDE ADEQUATE AIR FLOW ACROSS THE BOTTOM, BOLTS OR SCREWS USED FOR FASTENERS MUST NOT TOUCH ANY PARTS OR WIRING. PERFORM LEAKAGE TEST ON CUSTOMIZED INSTALLATIONS.
5. CAUTION CUSTOMERS AGAINST THE MOUNTING OF A PRODUCT ON SLOPING SHELF OR A TILTED POSITION, UNLESS THE PRODUCT IS PROPERLY SECURED.
6. A PRODUCT ON A ROLL-ABOUT CART SHOULD BE STABLE ON ITS MOUNTING TO THE CART. CAUTION THE CUSTOMER ON THE HAZARDS OF TRYING TO ROLL A CART WITH SMALL CASTERS ACROSS THRESHOLDS OR DEEP PILE CARPETS.
7. CAUTION CUSTOMERS AGAINST THE USE OF A CART OR STAND WHICH HAS NOT BEEN LISTED BY UNDERWRITERS LABORATORIES, INC. FOR USE WITH THEIR SPECIFIC MODEL OF TELEVISION RECEIVER OR GENERICALLY APPROVED FOR USE WITH T.V.'S OF THE SAME OR LARGER SCREEN SIZE.
8. CAUTION CUSTOMERS AGAINST THE USE OF EXTENSION CORDS, EXPLAIN THAT A FOREST OF EXTENSIONS SPROUTING FROM A SINGLE OUTLET CAN LEAD TO DISASTROUS CONSEQUENCES TO HOME AND FAMILY.

SERVICING PRECAUTIONS

CAUTION : Before servicing the A/V Receiver covered by this service data and its supplements and addends, read and follow the **SAFETY PRECAUTIONS**. **NOTE** : if unforeseen circumstances create conflict between the following servicing precautions and any of the safety precautions in this publication, always follow the safety precautions.

Remember Safety First:

General Servicing Precautions

1. Always unplug the A/V Receiver AC power cord from the AC power source before:
 - (1) Removing or reinstalling any component, circuit board, module, or any other assembly.
 - (2) Disconnecting or reconnecting any internal electrical plug or other electrical connection.
 - (3) Connecting a test substitute in parallel with an electrolytic capacitor.

Caution : A wrong part substitution or incorrect polarity installation of electrolytic capacitors may result in an explosion hazard.
2. Do not spray chemicals on or near this A/V Receiver or any of its assemblies.
3. Unless specified otherwise in this service data, clean electrical contacts by applying an appropriate contact cleaning solution to the contacts with a pipe cleaner, cottontipped swab, or comparable soft applicator.
Unless specified otherwise in this service data, lubrication of contacts is not required.
4. Do not defeat any plug/socket B+ voltage interlocks with which instruments covered by this service manual might be equipped.
5. Do not apply AC power to this A/V Receiver and/or any of its electrical assemblies unless all solid-state device heat sinks are correctly installed.
6. Always connect test instrument ground lead to the appropriate ground before connecting the test instrument positive lead. Always remove the test instrument ground lead last.

Insulation Checking Procedure

Disconnect the attachment plug from the AC outlet and turn the power on. Connect an insulation resistance meter(500V) to the blades of the attachment plug. The insulation resistance between each blade of the attachment plug and accessible conductive parts (Note 1) should be more than 1M-ohm.

Note 1 : Accessible Conductive Parts including Metal panels, Input terminals, Earphone jacks, etc.

Electrostatically Sensitive (ES) Devices

Some semiconductor (solid state) devices can be damaged easily by static electricity. Such components commonly are called Electrostatically Sensitive (ES) Devices. Examples of typical Es devices are integrated circuits and some field effect transistors and semiconductor chip components.

The following techniques should be used to help reduce the incidence of component damage caused by static electricity.

1. Immediately before handling any semiconductor component or semiconductor-equipped assembly, drain off any electrostatic charge on your body by touching a known earth ground. Alternatively, obtain and wear a commercially available discharging wrist strap device, which should be removed for potential shock reasons prior to applying power to the unit under test.
2. After removing an electrical assembly equipped with ES devices, place the assembly on a conductive surface such as aluminum foil, to prevent electrostatic charge buildup or exposure of the assembly.
3. Use only a grounded-tip soldering iron to solder or unsolder ES devices.
4. Use only an antistatic solder removal device. Some solder removal devices not classified a "anti-static" can generate electrical charges sufficient to damage ES devices.
5. Do not use freonpropelled chemicals. These can generate electrical charge sufficient to damage ES devices.
6. Do not remove a replacement ES device from its protective package until immediately before you are ready to install it. (Most replacement ES devices are packaged with leads electrically shorted together by conductive foam, aluminum foil, or comparable conductive material).
7. Immediately before removing the protective material from the leads of a replacement ES device, touch the protective material to the chassis or circuit assembly into which the device will be installed.

Caution : Be sure no power is applied to the chassis or circuit, and observe all other safety precautions.

8. Minimize bodily motions when handling unpackaged replacement ES devices. (Normally harmless motion such as the brushing together of your clothes fabric or the lifting of your foot from a carpeted floor can generate static electricity sufficient to damage an ES device.)

Specifications

Power Rating

85 Watts continuous average power into 6 Ohms at any frequency between 20Hz and 20kHz with all channels driven at less than 0.03% THD.

86 Watts continuous average power into 4 Ohms at any frequency between 20Hz and 20kHz with all channels driven at less than 0.03% THD.

IM Distortion (SMPTE)

80 Watts into 6 Ohms < 0.03 %

80 Watts into 4 Ohms < 0.03 %

IM Distortion (CCIF, Any Combination from 1kHz to 20kHz)

80 Watts into 6 Ohms < 0.03 %

80 Watts into 4 Ohms < 0.03 %

THD + Noise at 1 Watt into 6 Ohms

20Hz 0.03 %

1kHz 0.03 %

10kHz 0.03 %

20kHz 0.03 %

THD + Noise at 80 Watts into 6 Ohms

20Hz 0.03 %

1kHz 0.03 %

10kHz 0.03 %

20kHz 0.03 %

Frequency Response @ 1 Watt into 6 Ohms

10Hz to 20kHz + 0.5, -1.0dB

Power Bandwidth (-3dB)

5Hz to 45kHz

Gain

28dB

Amplifier Trimmer Adjustment Range

14 ± 2 dB

Damping Factor

>30

Dynamic Headroom into 6 Ohms

1.6dB

OMC Activation

< 3 Ohms across any speaker terminal

ATO Logic

SENSE Input Sensitivity >10mV rms

12V Trigger Input Voltage Range 10.0V to 20.0V DC, 100k Ohms

12V Trigger Output Current 25 ± 5mA, 470 Ohms

Input Impedance

25k Ohms

Input Sensitivity

80 Watt into 6 Ohms 1V rms

1 Watt into 6 Ohms 114mV rms

Damping Factor 20Hz to 20kHz >31

Rise Time

5kHz, 50V peak-to-peak square wave,
20% to 80% 4 µs

Power Consumption (Continuous, All Channels Driven)

Quiescent 84/168VA

Maximum 960/1920VA

80 Watts into 6 Ohms 744/1488VA

80 Watts into 4 Ohms 900/1800VA

GENERAL

Power (available in 240V) 120VAC/50-60Hz

Ambient Operating Temperature < 100 °F (40 °C)

Operating Temperature 68 °F (20 °C)

above ambient temperature

Ventilation Air Flow 150 cubic feet/minute maximum

Net Chassis Dimensions 17.2x5.3x17.8 inches (437x133x451 mm)

or 3 rack heights

Maximum Gross Dimensions 18.9x19.0x5.7 inches (480.1x481.7x144.8 mm)

(includes rack mounting hardware,

feet and speaker terminals)

Weight CI 9060, Packed 58 lb (26.4 Kg), 68 lb (31 Kg)

Weight CI 9120, Packed 80 lb (36.5 Kg), 90 lb (41 Kg)

FlexPad™

©2000 NAD Electronics International, a division of Lenbrook Industries Limited

ATO Logic™

©2000 NAD Electronics International, a division of Lenbrook Industries Limited

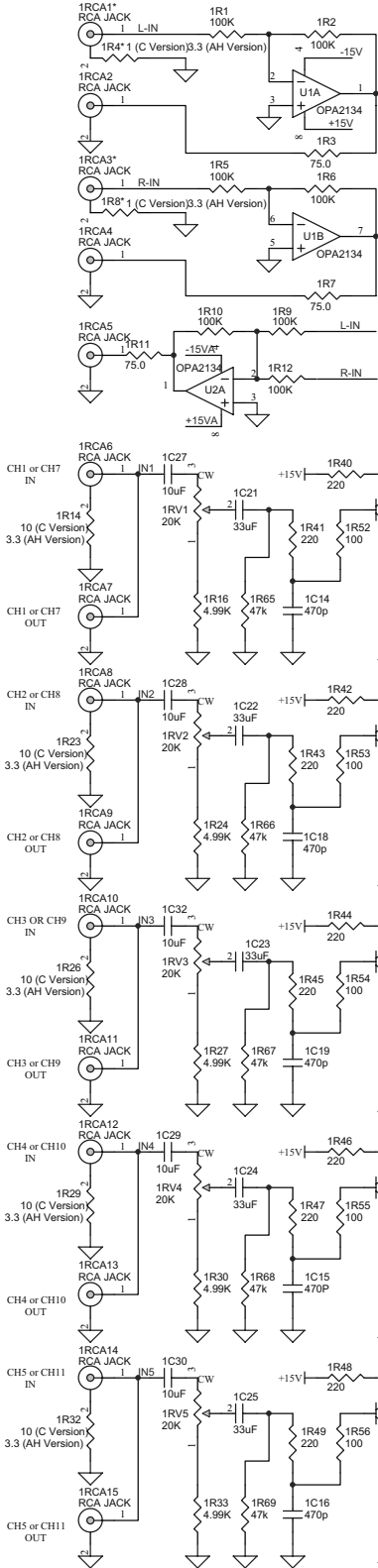

FlexPad

NOTE:
Six RCA Jumpers are provided for each FlexPad that is installed in a chassis. For Mono operation, an RCA Jumper is installed on the rear panel from J5 to J6, another from J7 to J8, another from J9 to J10, another from J11 to J12, another from J13 to J14, and the last from J15 to J16. J17 is not needed, and omitting it prevents the user from continuing the daisy-chain onto the second FlexPad, if installed.

Components with the *** mark are not inserted in C19120's second FlexPad.

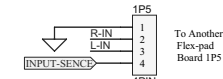
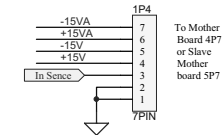
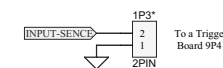
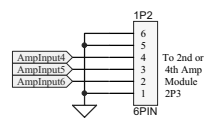
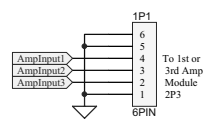
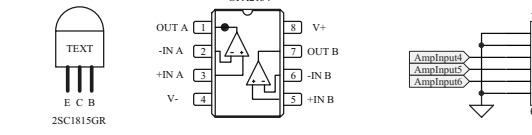
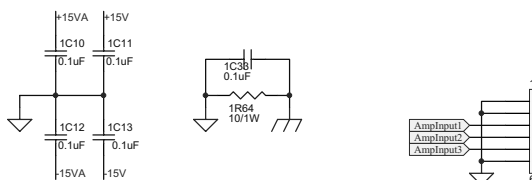
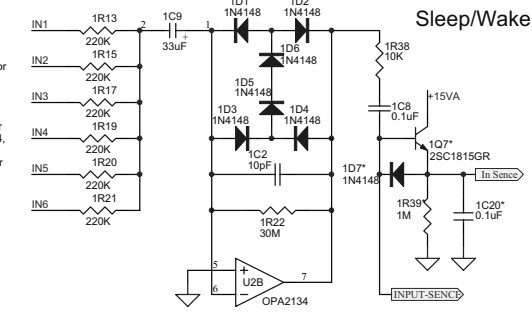

Note:
IN C19060, IP5 IS NOT INSERT

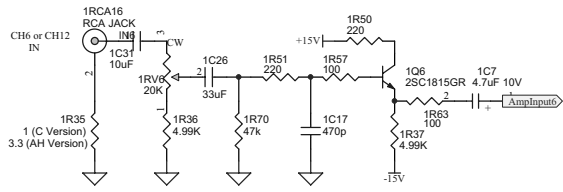

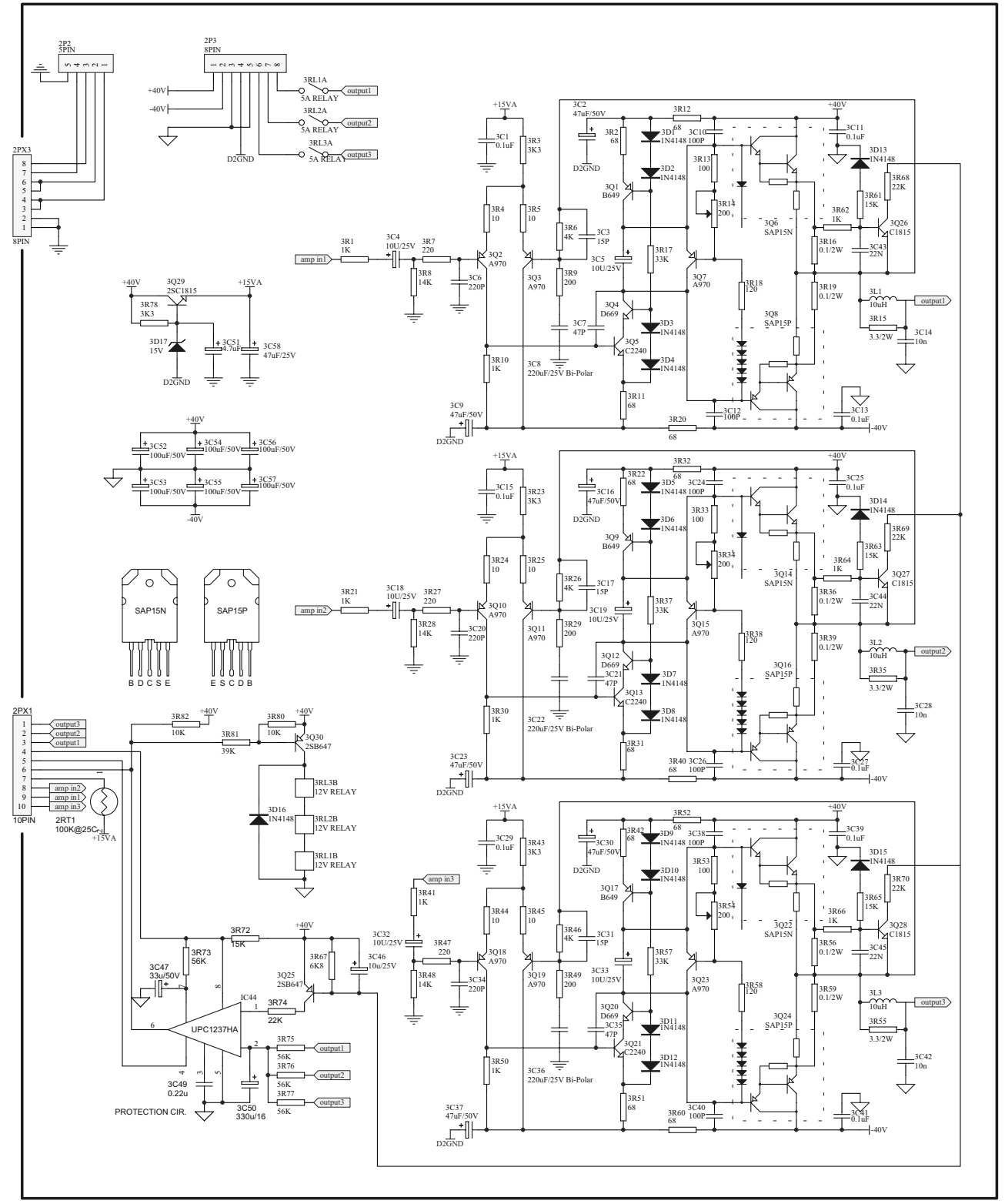
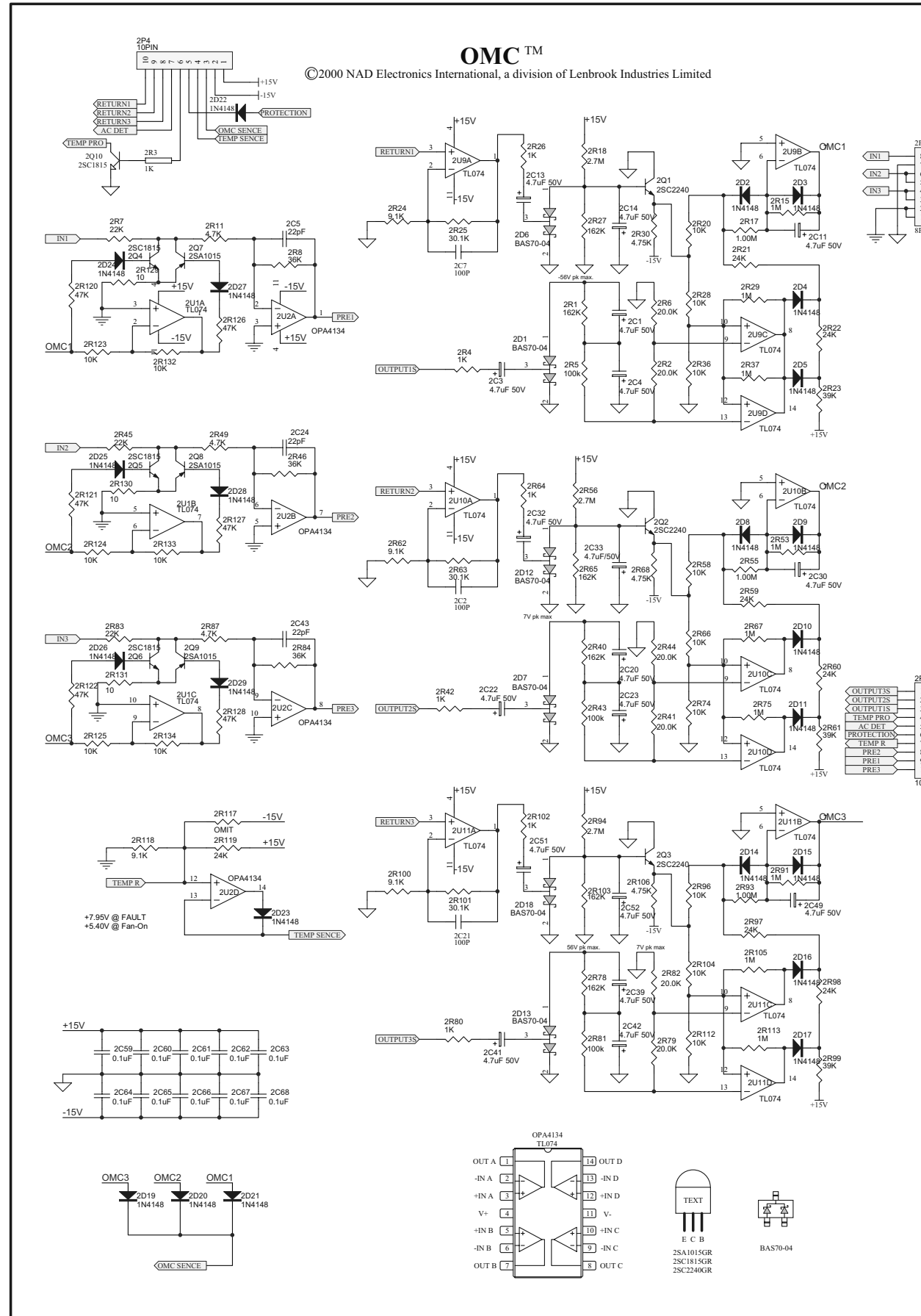

EXPLODED VIEW

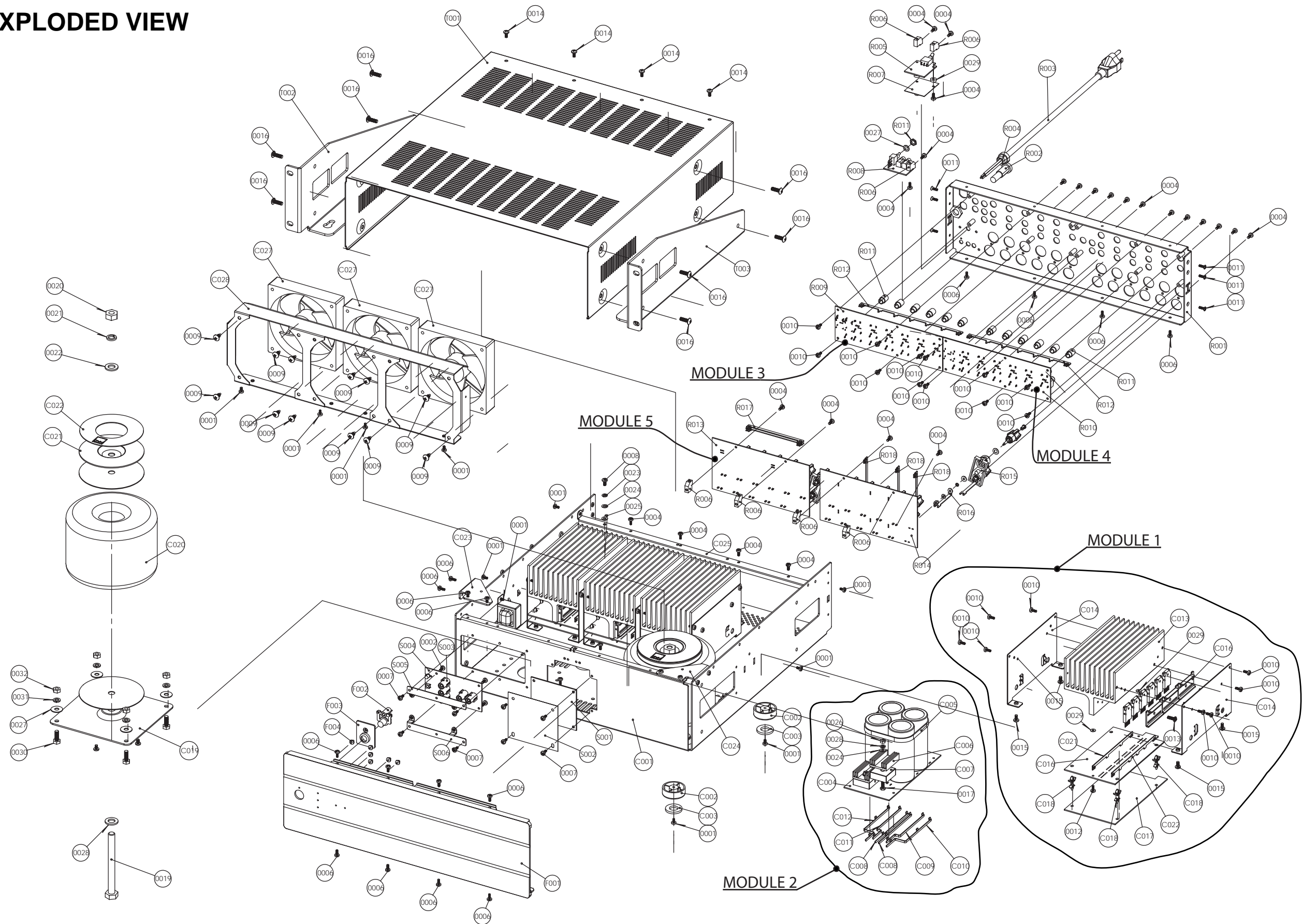

Exploded View

C001	66-008001-0	Chassis	1
C002	75-001008-0	Foot	4
C003	79-008001-0	Foot Pad, MX-48HF	4
C004	01-12002-01	Assembled Power Board 1 (Horizontal)	1
C005	84-008001-0	Cable Tie	1
C006	70-008002-0	Heatsink B, H=39mm	2
C007	33-33542-00	Bridge	2
C008	69-008002-0	Bus Bar A	2
C009	69-008003-0	Bus Bar B	1
C010	69-008004-0	Bus Bar C	1
C011	69-008005-0	Bus Bar D	1
C012	69-008006-0	Bus Bar E	1
C013	70-008001-1	Heatsink	4
C014	66-008003-0	Heatsink Support	8
C015	66-008003-0	Transistor Clamper, with Clamper Brace	12
C016	01-12001-01	Assembled AMP Board (up)	4
C017	01-12001-02	Assembled AMP Board (lower)	4
C018	85-008002-0	Spacer Support	16
C019	66-008004-0	Transformer Plate	2
C020	18-20102-20	Main Transformer (C)	2
	18-20102-10	Main Transformer (AH)	2
C021	66-005007-0	Metal Disc	2
C022	94-005004-0	Transformer label	2
C023	66-008010-0	Subfascia Left Bracket	1
C024	66-008011-0	Subfascia Right Bracket	1
C026	66-008012-0	Fan Housing	1
C027	35-01224-00	Fan	3
C028	33- 33542-01	Bridge with Heatsink B, & 0017/24/26/28	2
F001	67-008001-0	Fascia	1
F002	74-008001-0	Power Button	1
F003	77-008001-0	Power Button Housing	1
F004	76-008001-0	LED Lens	6

S001	78-008001-0	Protect Film	1
S002		Assembled Power Board 2 (Vertical)	1
S003	75-005001-0	Sleeve (1P)	5
S004	01-12006-00	Assembled Key Board	1
S005	66-008008-0	LED pcb Top Bracket	1
S006	66-008009-0	LED pcb Bottom Bracket	1

T001	66-008002-0	Top Cover	1
T002	66-008005-0	Rack Mount Left Bracket	1
T003	66-008006-0	Rack Mount Right Bracket	1

R001	67-008003-0	Rear Panel (C)	1
	67-008002-0	Rear Panel (AH)	1
R002	20-20000-03	Fuse Holder	1
R003	15-13125-10	9120 AC Cord (AH Version)	1
	15-05250-20	9060 AC Cord (C Version), Section 1	1
	15-05250-21	IEC Male Connector (C Version), Section 2	1
R004	85-008003-0	Strain Relief Bushing (AH)	1
	85-008004-0	Strain Relief bushing (C)	1
R005	01-12007-00	Assembled Switch Board	1

R006	85-008001-0	Spacer Support	7
R007	78-008002-0	Protect Film (B)	1
R008	01-12008-00	Assembled Trigger Board	1
R009	01-12003-01	Assembled Flex Pad Board 1	1
R010	01-12003-02	Assembled Flex Pad Board 2	1
R011	73-003001-0	Rotate Knob	12
R012	69-008009-0	BUS BAR H	2
R013	01-12004-00	Assembled Mother Board	1
R014	01-12005-00	Assembled Slave Mother Board	1
R015	17-01001-00	Binding Post	12
R016	69-008001-0	BDP Pin	24
R017	69-008010-0	BUS BAR I	2
R018	69-008011-0	BUS BAR J	3

0001	61-023106-0	Self Taping Screw, STB3×6-HOZn	22
0002	61-023206-0	Self Taping Screw, BTB3×6-HOZn	4
0003	61-023408-0	Self Taping Screw, PTB3×8-Ozn	24
0004	61-023108-5	Self Taping Screw, STB3.5×8-HOZn	20
0005	61-023208-5	Self Taping Screw, BTB3.5×8-HOZn	8
0006	61-024108-1	Self Taping Screw, STB4X8-HZn	1
0007	61-025112-0	Self Taping Screw, TB5×12A-OZn	12
0008	61-033506-0	Machine Screw, MP3×6(White Zn painted)	48
0009	61-073508-0	Machine Screw, MO3×8-OZn	6
0010	61-023510-0	Machine Screw, MB3×10-OZn	8
0011	61-044516-0	Machine Screw, MT4×16-Ozn	12
0012	61-023510-0	Machine Screw, MB3×10-Oz	8
0013	61-024506-0	Machine Screw, MB4×6-OZn	16
0014	61-024508-0	Machine Screw, MB4×8-Ozn	4
0015	64-104020-0	Bolt, GB5781-86 M4×20	2
0016	61-025515-0	Machine Screw, MB5×15-Ozn	8
0017	62-011002-0	Nut, GB6170 M10	2
0018	63-021020-0	Spring Washer, GB859-87 •10	2
0019	64-110103-0	Blot, GB5782-83 M10x103	2
0020	63-040408-0	Spring Washer, GB862.2 •4	1
0021	63-010408-0	Washer, GB97.1-85 •4	1
0022	32-20608-00	Grounding Tab, RNBL2-4	1
0023	62-010402-0	Nut, GB6170 M4	3
0024	63-010608-0	Washer, ID=•6, OD=•10	9
0025	63-020408-0	Spring Washer, GB859-87 •4	1
0026	86-004001-0	Plastic Washer, •3×3	10
0027	64-106016-0	Bolt, GB5783-86, M6x16	8
0028	63-020610-0	Spring Washer, GB859-87,•6	8
0029	62-010602-0	Nut, GB6170, M6	8

CI 9060 / 9120 Six and Twelve Channel Amplifier
Parts List

<u>Reference Number</u>	<u>Part number</u>	<u>Description</u>
Module 1	01-12001-00	Amplifier Module Attached to the Heatsink
Module 2	01-12002-00/01-06002-00	Power Supply Module
Module 3	01-12002-01 C-version 01-12002-02 AH-version	FlexPad Module Channel 1-6
Module 4	01-12003-01 C-version 01-12003-02 AH-version	FlexPad Module Channel 7-12
Module 5**	1-12004-xx / 1-12005-xx	Speaker Terminal Modules and ATO Logic M/S
RCA J	29-20001-01	FlexPad RCA Jumpers

Module 5**

- 01-12004-20 ATO Logic Mother Board, and Speaker terminals, C-version
- 01-12004-10 ATO Logic Mother Board, and Speaker terminals, AH-version
- 01-12005-20 ATO Logic Slave Board, and Speaker terminals, C-version
- 01-12005-10 ATO Logic Slave Board, and Speaker terminals, AH-version

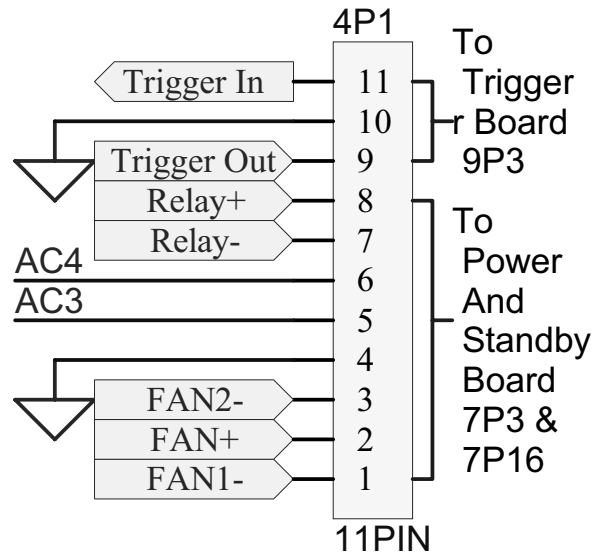

When installing the 01-12004-10 or the 01-12004-20 into the CI9060, do reuse the 11PIN 4P1 wire assembly from the original Mother board assembly. The 4P1 wire assembly of the 01-12004-10/20 are only long enough to fit into the CI9120

MEMO

30-42002-00 Shoulder Washer Assembly Instruction

63-120530-0 Shoulder Washer

90-008005-0 Shoulder Washer Polybag

61-275318-0 SAE#10-32

12-01101-05 RELAY 832A-1A-C-BH DC 12V (7RL1)

SERVICE MANUAL

C1 9060/9120

© NAD 2011

NAD ELECTRONICS LTD
TORONTO