

**D1050**

**USB DAC**

# **SERVICE MANUAL**

**D1050**

**USB DAC**

**NAD**

# TABLE OF CONTENTS

DESCRIPTION	PAGE
SERVICE CAUTION.....	3-4
SPECIFICATIONS.....	5
BLOCK DIAGRAM.....	6
WIRING DIAGRAM.....	7-10
TROUBLE SHOOTING GUIDE A.....	11
TROUBLE SHOOTING GUIDE B.....	12
EXPLODED VIEW .....	13-14
EXPLODED VIEW PARTS LIST .....	13-14
CIRCUIT DIAGRAMS.....	15-21
PCB LAYOUT.....	22-29
ELECTRICAL VIEW PARTS LIST.....	30-39

# PRODUCT SAFETY SERVICING GUIDELINES

CAUTION : DO NOT ATTEMPT TO MODIFY THIS PRODUCT IN ANY WAY. NEVER PERFORM CUSTOMIZED INSTALLATIONS WITHOUT MANUFACTURER'S APPROVAL. UNAUTHORIZED MODIFICATIONS WILL NOT ONLY VOID THE WARRANTY, BUT MAY LEAD TO YOUR BEING LIABLE FOR ANY RESULTING PROPERTY DAMAGE OR USER INJURY.

SERVICE WORK SHOULD BE PERFORMED ONLY AFTER YOU ARE THOROUGHLY FAMILIAR WITH ALL OF THE FOLLOWING SAFETY CHECKS AND SERVICING GUIDELINES. TO DO OTHERWISE, INCREASES THE RISK OF POTENTIAL HAZARDS AND INJURY TO THE USER.

WHILE SERVICING, USE AN ISOLATION TRANSFORMER FOR PROTECTION FROM AC LINE SHOCK.

## SAFETY CHECKS

AFTER THE ORIGINAL SERVICE PROBLEM HAS BEEN CORRECTED. A CHECK SHOULD BE MADE OF THE FOLLOWING.

### SUBJECT : FIRE & SHOCK HAZARD

1. BE SURE THAT ALL COMPONENTS ARE POSITIONED IN SUCH A WAY AS TO AVOID POSSIBILITY OF ADJACENT COMPONENT SHORTS. THIS IS ESPECIALLY IMPORTANT ON THOSE MODULES WHICH ARE TRANSPORTED TO AND FROM THE REPAIR SHOP.
2. NEVER RELEASE A REPAIR UNLESS ALL PROTECTIVE DEVICES SUCH AS INSULATORS, BARRIERS, COVERS, SHIELDS, STRAIN RELIEFS, POWER SUPPLY CORDS, AND OTHER HARDWARE HAVE BEEN REINSTALLED PER ORIGINAL DESIGN. BE SURE THAT THE SAFETY PURPOSE OF THE POLARIZED LINE PLUG HAS NOT BEEN DEFEATED.
3. SOLDERING MUST BE INSPECTED TO DISCOVER POSSIBLE COLD SOLDER JOINTS, SOLDER SPLASHES OR SHARP SOLDER POINTS. BE CERTAIN TO REMOVE ALL LOOSE FOREIGN PARTICLES.
4. CHECK FOR PHYSICAL EVIDENCE OF DAMAGE OR DETERIORATION TO PARTS AND COMPONENTS. FOR FRAYED LEADS, DAMAGED INSULATION (INCLUDING AC CORD). AND REPLACE IF NECESSARY FOLLOW ORIGINAL LAYOUT, LEAD LENGTH AND DRESS.
5. NO LEAD OR COMPONENT SHOULD TOUCH A RECEIVING TUBE OR A RESISTOR RATED AT 1 WATT OR MORE. LEAD TENSION AROUND PROTRUDING METAL SURFACES MUST BE AVOIDED.
6. ALL CRITICAL COMPONENTS SUCH AS FUSES, FLAMEPROOF RESISTORS, CAPACITORS, ETC. MUST BE REPLACED WITH EXACT FACTORY TYPES, DO NOT USE REPLACEMENT COMPONENTS OTHER THAN THOSE SPECIFIED OR MAKE UNRECOMMENDED CIRCUIT MODIFICATIONS.
7. AFTER RE-ASSEMBLY OF THE SET ALWAYS PERFORM AN AC LEAKAGE TEST ON ALL EXPOSED METALLIC PARTS OF THE CABINET, (THE CHANNEL SELECTOR KNOB, ANTENNA TERMINALS. HANDLE AND SCREWS) TO BE SURE THE SET IS SAFET TO OPERATE WITHOUT DANGER OF ELECTRICAL SHOCK. DO NOT USE A LINE ISOLATION TRANSFORMER DURING THIS TEST USE AN AC VOLTMETER, HAVING 5000 OHMS PER VOLT OR MORE SENSITIVITY, IN THE FOLLOWING MANNER; CONNECT A 1500 OHM 10 WATT RESISTOR, PARALLELED BY A .15 MFD, 150V AC TYPE CAPACITOR BETWEEN A KNOWN GOOD EARTH GROUND (WATER PIPE, CONDUIT, ETC.) AND THE EXPOSED METALLIC PARTS, ONE AT A TIME.  
MEASURE THE AC VOLTAGE ACROSS THE COMBINATION OF 1500 OHM RESISTOR AND .15 MFD CAPACITOR.  
REVERSE THE AC PLUG AND REPEAT AC VOLTAGE MEASUREMENTS FOR EACH EXPOSED METALLIC PART.

VOLTAGE MEASURE MUST NOT EXCEED 75 VOLTS R.M.S. THIS CORRESPONDS TO 0.5 MILLIAMP AC ANY VALUE EXCEEDING THIS LIMIT CONSTITUTES A POTENTIAL SHOCK HAZARD AND MUST BE CORRECTED IMMEDIATELY.

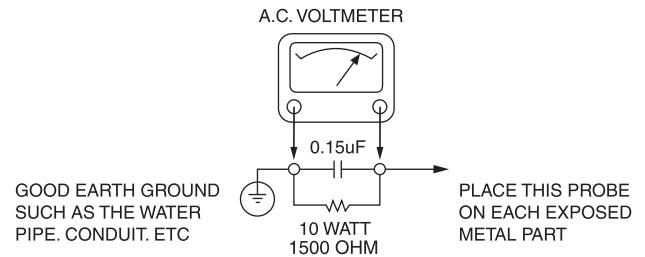

### SUBJECT : GRAPHIC SYMBOLS



THE LIGHTNING FLASH WITH ARROWHEAD SYMBOL, WITHIN AN EQUILATERAL TRIANGLE, IS INTENDED TO ALERT THE USER TO THE PRESENCE OF UNINSULATED "DANGEROUS VOLTAGE" WITHIN THE PRODUCT'S ENCLOSURE THAT MAY BE OF SUFFICIENT MAGNITUDE TO CONSTITUTE A RISK OF ELECTRIC SHOCK.



THE EXCLAMATION POINT WITHIN AN EQUILATERAL TRIANGLE IS INTENDED TO ALERT THE USER TO THE PRESENCE OF IMPORTANT OPERATING AND MAINTENANCE (SERVICING) INSTRUCTIONS IN THE LITERATURE ACCOMPANYING THE APPLIANCE.

### SUBJECT : TIPS ON PROPER INSTALLATION

1. NEVER INSTALL ANY PRODUCT IN A CLOSED-IN RECESS, CUBBYHOLE OR CLOSELY FITTING SHELF SPACE. OVER OR CLOSE TO HEAT DUCT, OR IN THE PATH OF HEATED AIR FLOW.
2. AVOID CONDITIONS OF HIGH HUMIDITY SUCH AS: OUTDOOR PATIO INSTALLATIONS WHERE DEW IS A FACTOR, NEAR STEAM RADIATORS WHERE STEAM LEAKAGE IS A FACTOR, ETC.
3. AVOID PLACEMENT WHERE DRAPERIES MAY OBSTRUCT REAR VENTING. THE CUSTOMER SHOULD ALSO AVOID THE USE OF DECORATIVE SCARVES OR OTHER COVERINGS WHICH MIGHT OBSTRUCT VENTILATION.
4. WALL AND SHELF MOUNTED INSTALLATIONS USING A COMMERCIAL MOUNTING KIT MUST FOLLOW THE FACTORY APPROVED MOUNTING INSTRUCTIONS A PRODUCT MOUNTED TO A SHELF OR PLATFORM MUST RETAIN ITS ORIGINAL FEET (OR THE EQUIVALENT THICKNESS IN SPACERS) TO PROVIDE ADEQUATE AIR FLOW ACROSS THE BOTTOM, BOLTS OR SCREWS USED FOR FASTENERS MUST NOT TOUCH ANY PARTS OR WIRING. PERFORM LEAKAGE TEST ON CUSTOMIZED INSTALLATIONS.
5. CAUTION CUSTOMERS AGAINST THE MOUNTING OF A PRODUCT ON SLOPING SHELF OR A TILTED POSITION, UNLESS THE PRODUCT IS PROPERLY SECURED.
6. A PRODUCT ON A ROLL-ABOUT CART SHOULD BE STABLE ON ITS MOUNTING TO THE CART. CAUTION THE CUSTOMER ON THE HAZARDS OF TRYING TO ROLL A CART WITH SMALL CASTERS ACROSS THRESHOLDS OR DEEP PILE CARPETS.
7. CAUTION CUSTOMERS AGAINST THE USE OF A CART OR STAND WHICH HAS NOT BEEN LISTED BY UNDERWRITERS LABORATORIES, INC. FOR USE WITH THEIR SPECIFIC MODEL OF TELEVISION RECEIVER OR GENERICALLY APPROVED FOR USE WITH T.V.'S OF THE SAME OR LARGER SCREEN SIZE.
8. CAUTION CUSTOMERS AGAINST THE USE OF EXTENSION CORDS, EXPLAIN THAT A FOREST OF EXTENSIONS SPROUTING FROM A SINGLE OUTLET CAN LEAD TO DISASTROUS CONSEQUENCES TO HOME AND FAMILY.

# SERVICING PRECAUTIONS

**CAUTION** : Before servicing the A/V Receiver covered by this service data and its supplements and addends, read and follow the **SAFETY PRECAUTIONS**. **NOTE** : if unforeseen circumstances create conflict between the following servicing precautions and any of the safety precautions in this publication, always follow the safety precautions.

*Remember Safety First:*

## General Servicing Precautions

1. Always unplug the A/V Receiver AC power cord from the AC power source before:
  - (1) Removing or reinstalling any component, circuit board, module, or any other assembly.
  - (2) Disconnecting or reconnecting any internal electrical plug or other electrical connection.
  - (3) Connecting a test substitute in parallel with an electrolytic capacitor.**Caution** : A wrong part substitution or incorrect polarity installation of electrolytic capacitors may result in an explosion hazard.
2. Do not spray chemicals on or near this A/V Receiver or any of its assemblies.
3. Unless specified otherwise in this service data, clean electrical contacts by applying an appropriate contact cleaning solution to the contacts with a pipe cleaner, cottontipped swab, or comparable soft applicator.  
Unless specified otherwise in this service data, lubrication of contacts is not required.
4. Do not defeat any plug/socket B+ voltage interlocks with which instruments covered by this service manual might be equipped.
5. Do not apply AC power to this A/V Receiver and/or any of its electrical assemblies unless all solid-state device heat sinks are correctly installed.
6. Always connect test instrument ground lead to the appropriate ground before connecting the test instrument positive lead. Always remove the test instrument ground lead last.

## Insulation Checking Procedure

Disconnect the attachment plug from the AC outlet and turn the power on. Connect an insulation resistance meter(500V) to the blades of the attachment plug. The insulation resistance between each blade of the attachment plug and accessible conductive parts (Note 1) should be more than 1M-ohm.

**Note 1** : Accessible Conductive Parts including Metal panels, Input terminals, Earphone jacks, etc.

## Electrostatically Sensitive (ES) Devices

Some semiconductor (solid state) devices can be damaged easily by static electricity. Such components commonly are called Electrostatically Sensitive (ES) Devices. Examples of typical Es devices are integrated circuits and some field effect transistors and semiconductor chip components.

The following techniques should be used to help reduce the incidence of component damage caused by static electricity.

1. Immediately before handling any semiconductor component or semiconductor-equipped assembly, drain off any electrostatic charge on your body by touching a known earth ground. Alternatively, obtain and wear a commercially available discharging wrist strap device, which should be removed for potential shock reasons prior to applying power to the unit under test.
2. After removing an electrical assembly equipped with ES devices, place the assembly on a conductive surface such as aluminum foil, to prevent electrostatic charge buildup or exposure of the assembly.
3. Use only a grounded-tip soldering iron to solder or unsolder ES devices.
4. Use only an antistatic solder removal device. Some solder removal devices not classified a "anti-static" can generate electrical charges sufficient to damage ES devices.
5. Do not use freonpropelled chemicals. These can generate electrical charge sufficient to damage ES devices.
6. Do not remove a replacement ES device from its protective package until immediately before you are ready to install it. (Most replacement ES devices are packaged with leads electrically shorted together by conductive foam, aluminum foil, or comparable conductive material).
7. Immediately before removing the protective material from the leads of a replacement ES device, touch the protective material to the chassis or circuit assembly into which the device will be installed.

**Caution** : Be sure no power is applied to the chassis or circuit, and observe all other safety precautions.

8. Minimize bodily motions when handing unpackaged replacement ES devices. (Normally harmless motion such as the brushing together of your clothes fabric or the lifting of your foot from a carpeted floor can generate static electricity sufficient to damage an ES device.)

# Specifications

D 1050	SOURCE		
	AUDIO SPECIFICATIONS	USB	COAXIAL
Maximum Output Level	2.0V	2.0V	2.0V
Signal/Noise Ratio (A-weighted)	≥115dB	≥115dB	≥115dB
Crosstalk (1kHz)	≥110dB	≥120dB	≥120dB
Crosstalk (10kHz)	≥105dB	≥105dB	≥130dB
Frequency Response (20Hz - 20kHz)	±0.5dB	0dB to -0.3dB	0dB to -0.3dB
Total Harmonic Distortion	≤0.001%	≤0.0006%	≤0.0006%
IMD (SMPTE)	0.005%	0.005%	0.005%
IMD (CCIF)	0.003%	0.003%	0.003%
<b>GENERAL</b>			
Standby Power	≤0.5W		
Supports bit rate/sample rate	up to 24/192		
Unit Dimension (WxHxD) - Gross*	58 x 186 x 208mm 2 5/16 x 7 3/8 x 8 1/4" **		
Net Weight	1kg (2.2lb)		
Shipping Weight	2.1kg (4.6lb)		

\* Gross dimensions include extended buttons and rear panel terminals.

\*\* Non-metric measurements are approximate. NAD Electronics will not assume any liability for errors being made by retailers, custom installers, cabinet makers, or other end users based on information contained in this document.

Note: Installers should allow a minimum clearance of 55mm for wire/cable management.

# BLOCK DIAGRAM

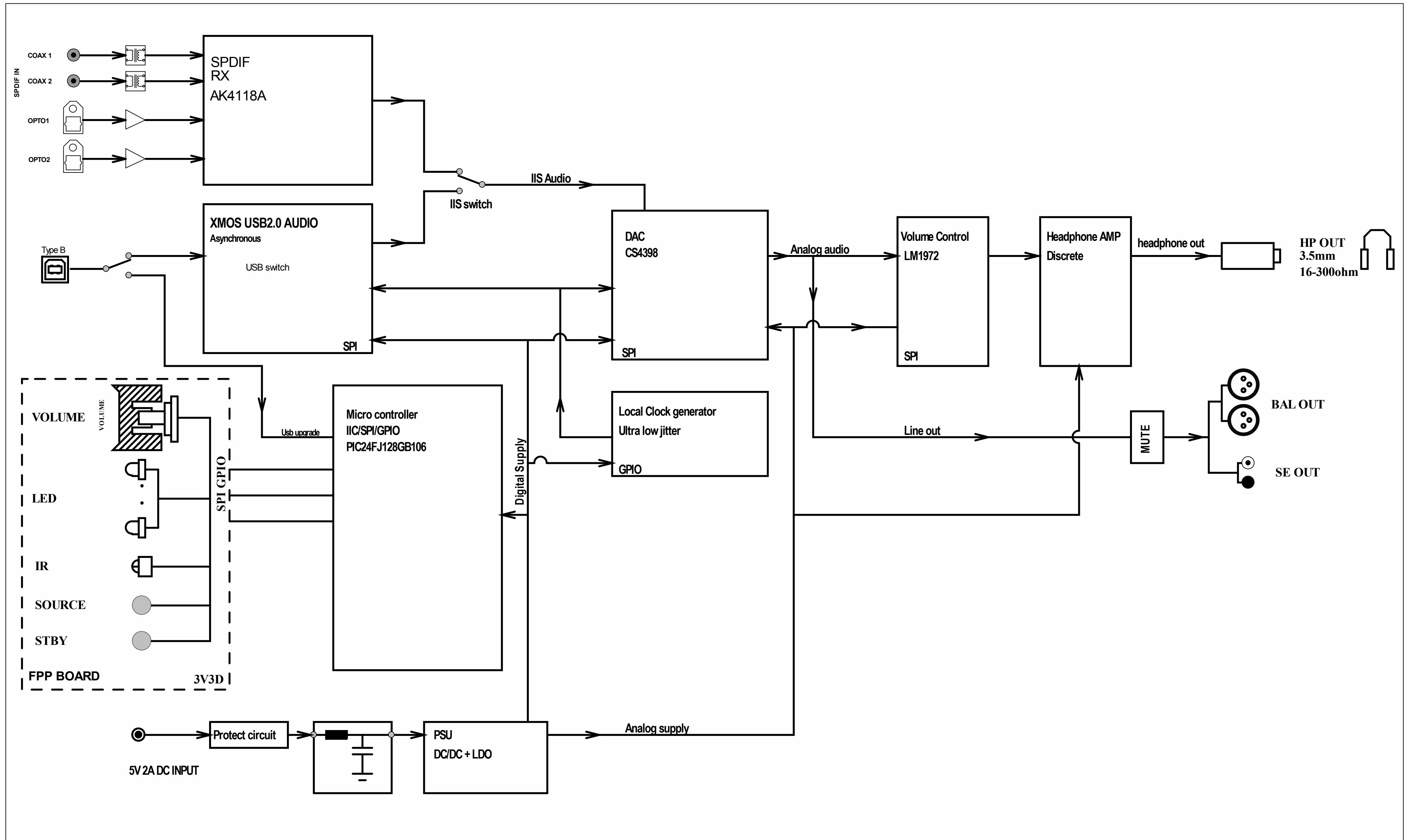

# WIRING DIAGRAM

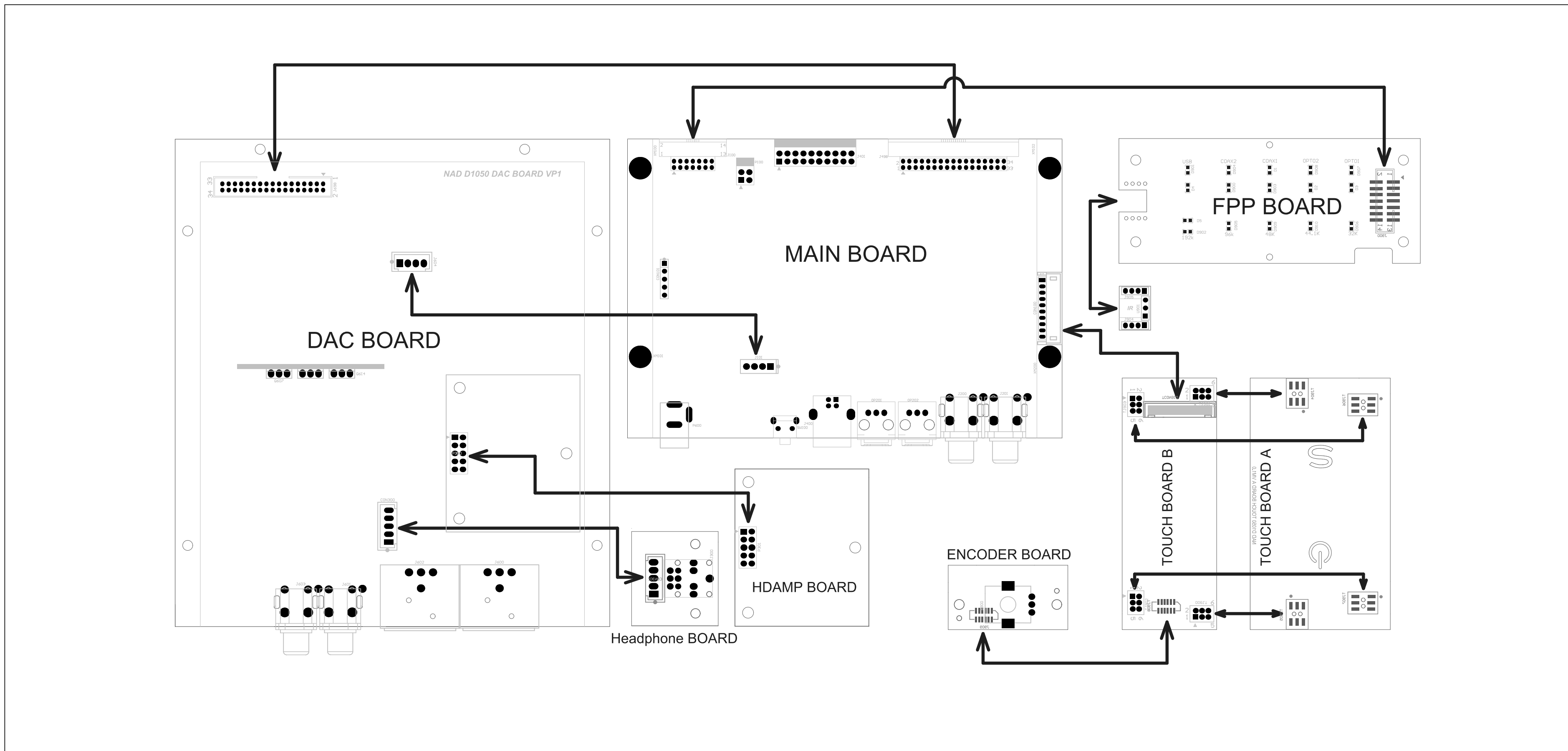

# XS1-L01A-TQ128

## MAIN BOARD

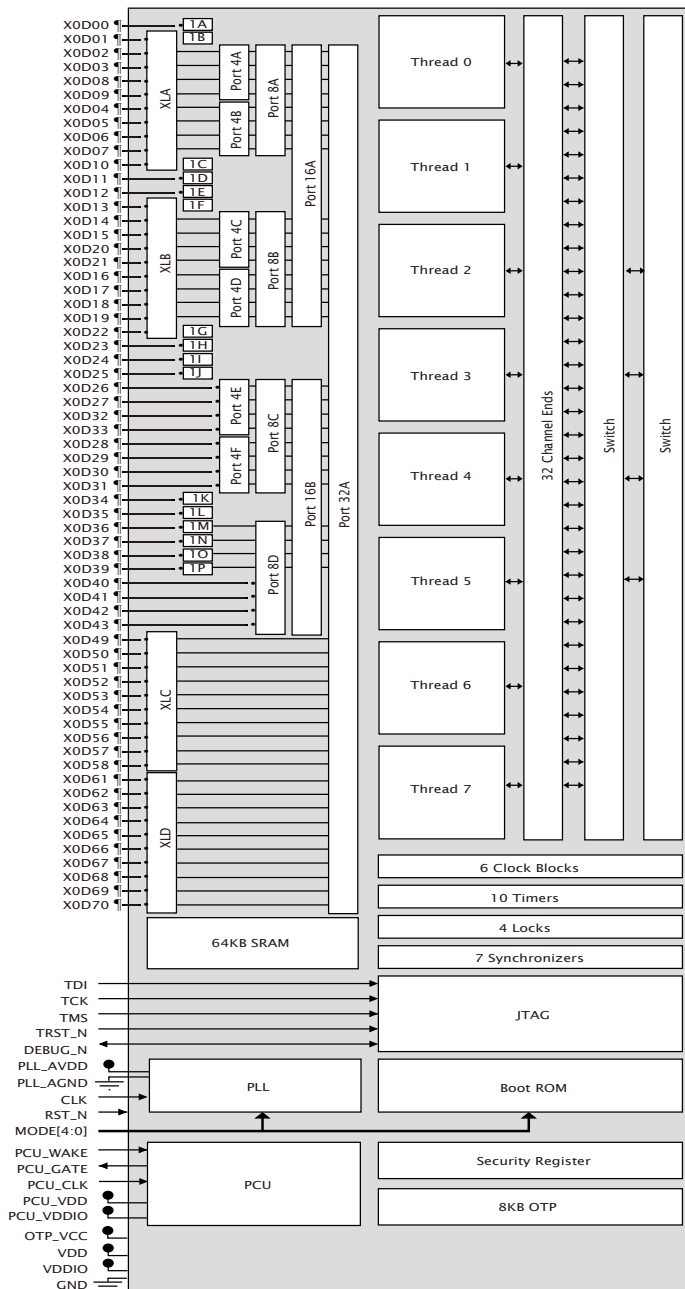



# AL4118A MAIN BOARD

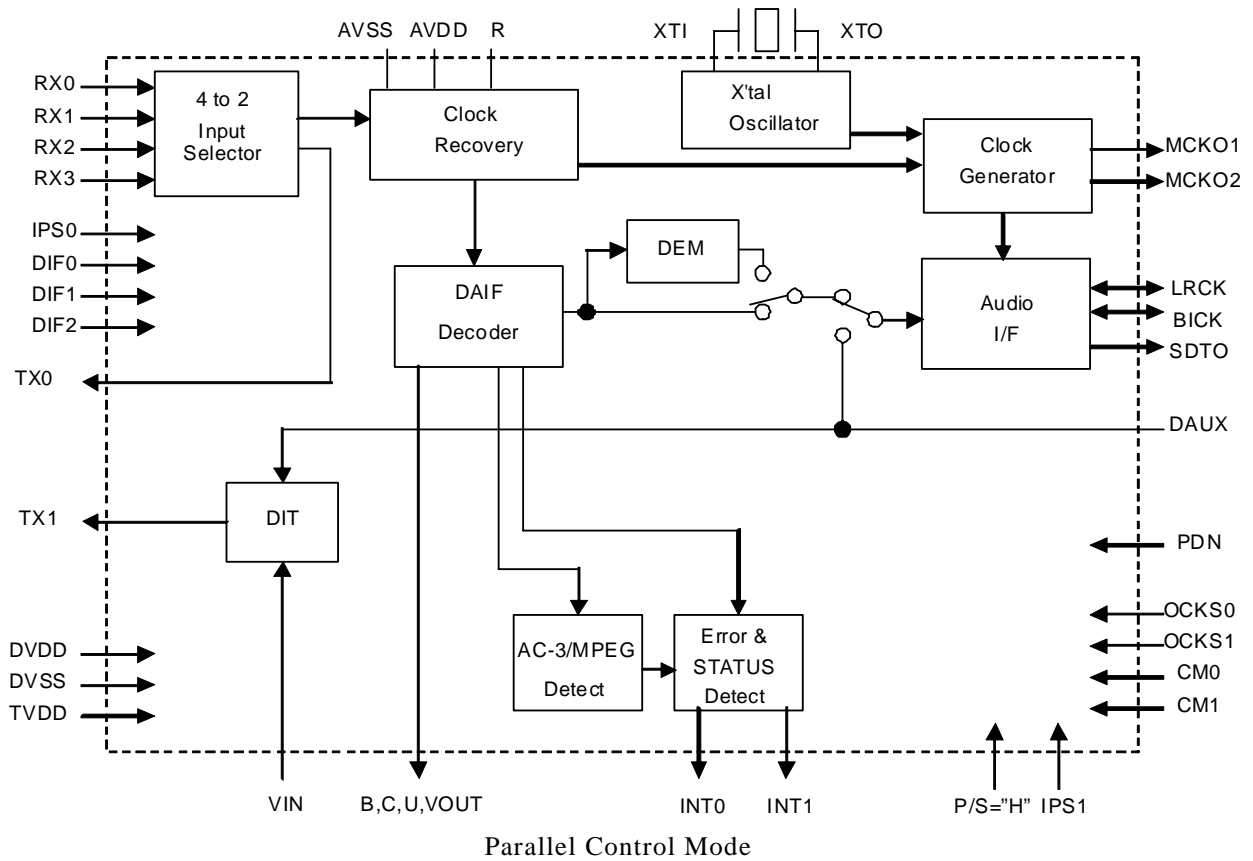
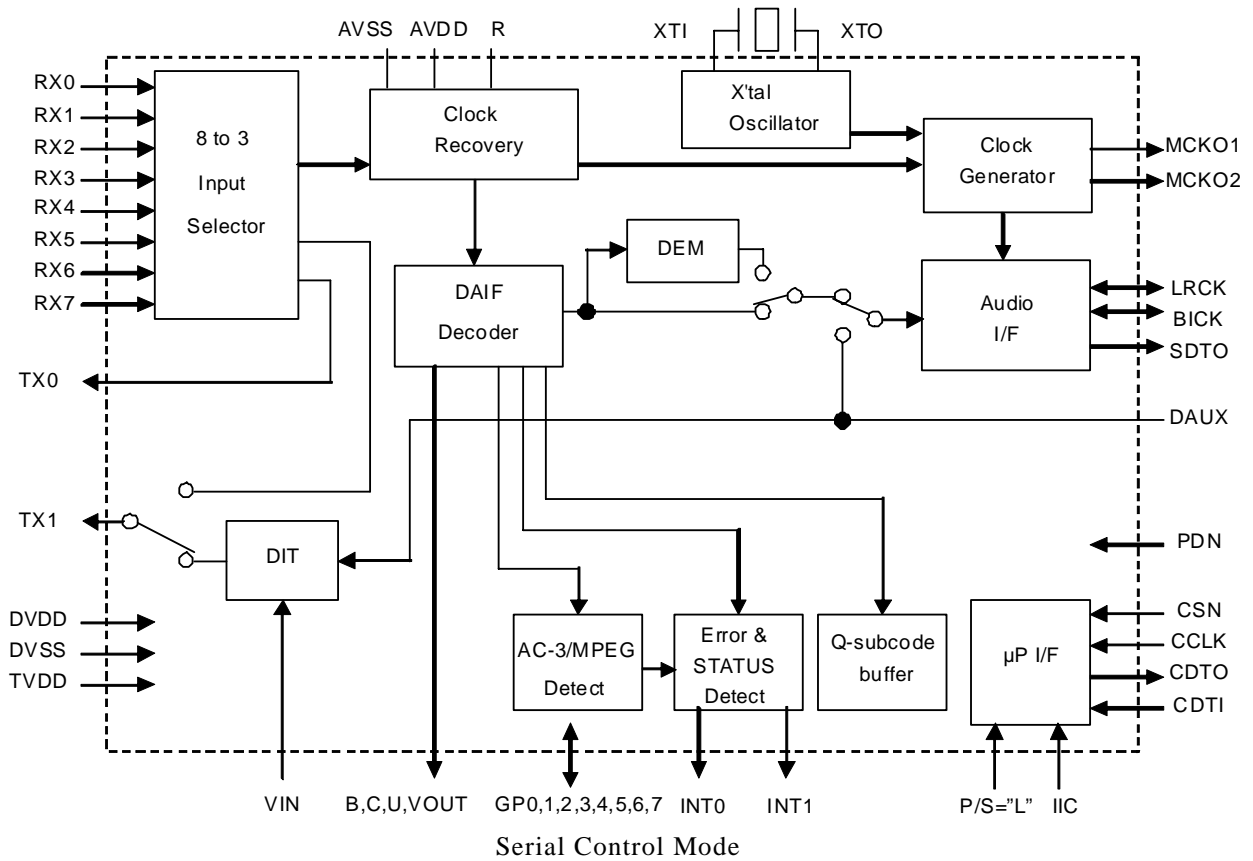

# PIC24FJ128GB106 MAIN BOARD

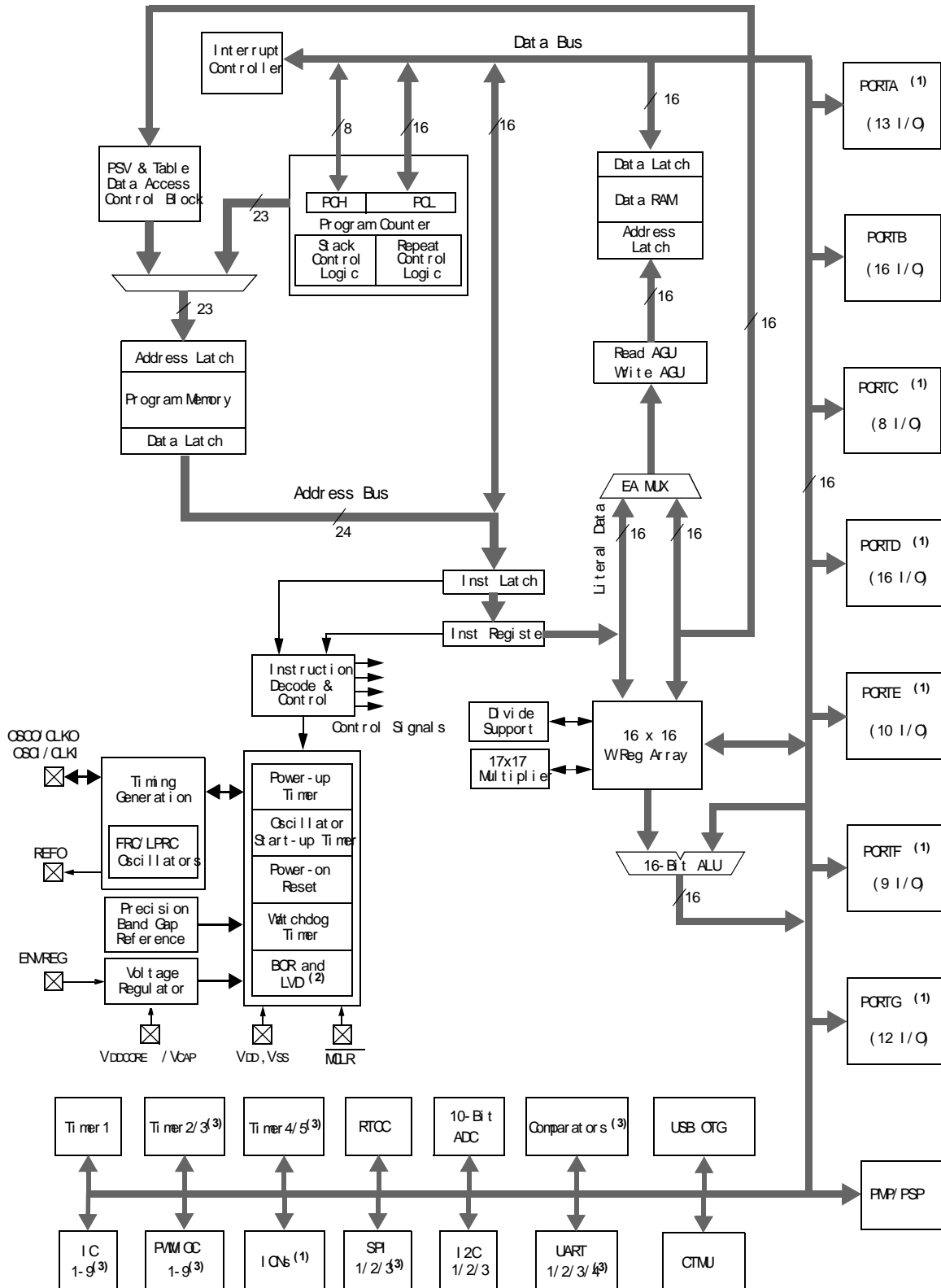

# TROUBLE SHOOTING GUIDE A

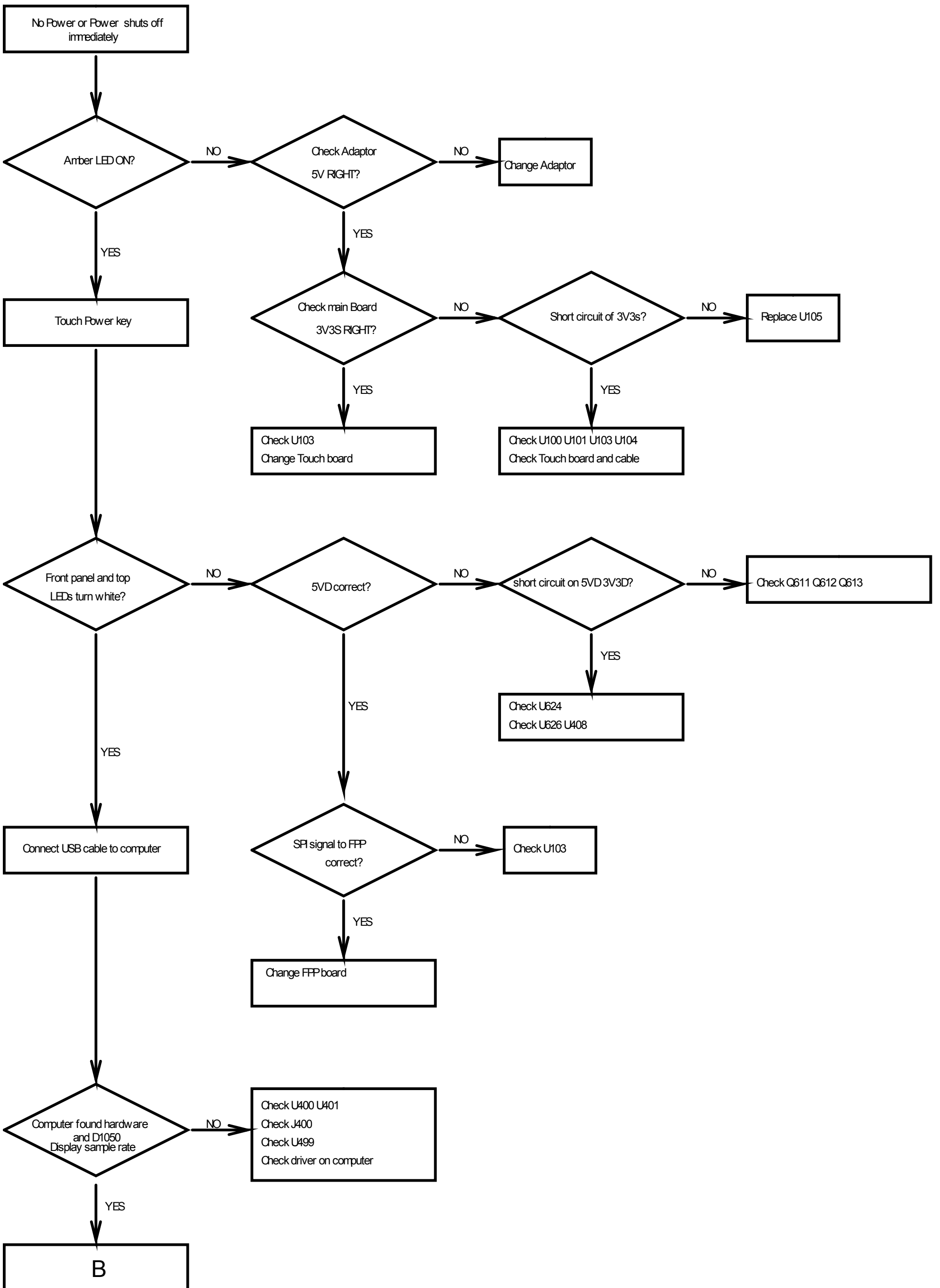

# TROUBLE SHOOTING GUIDE B

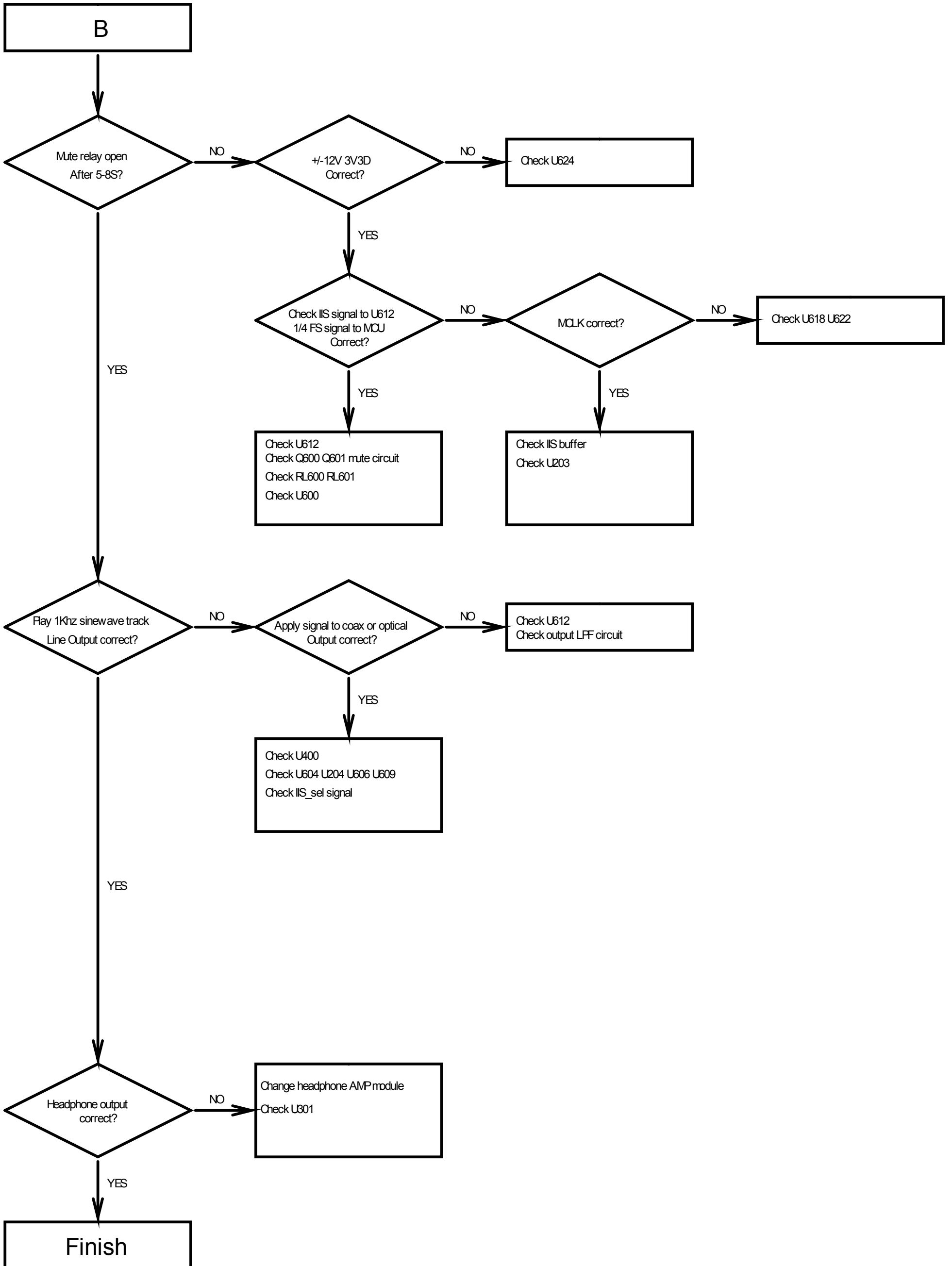

# EXPLODED VIEW

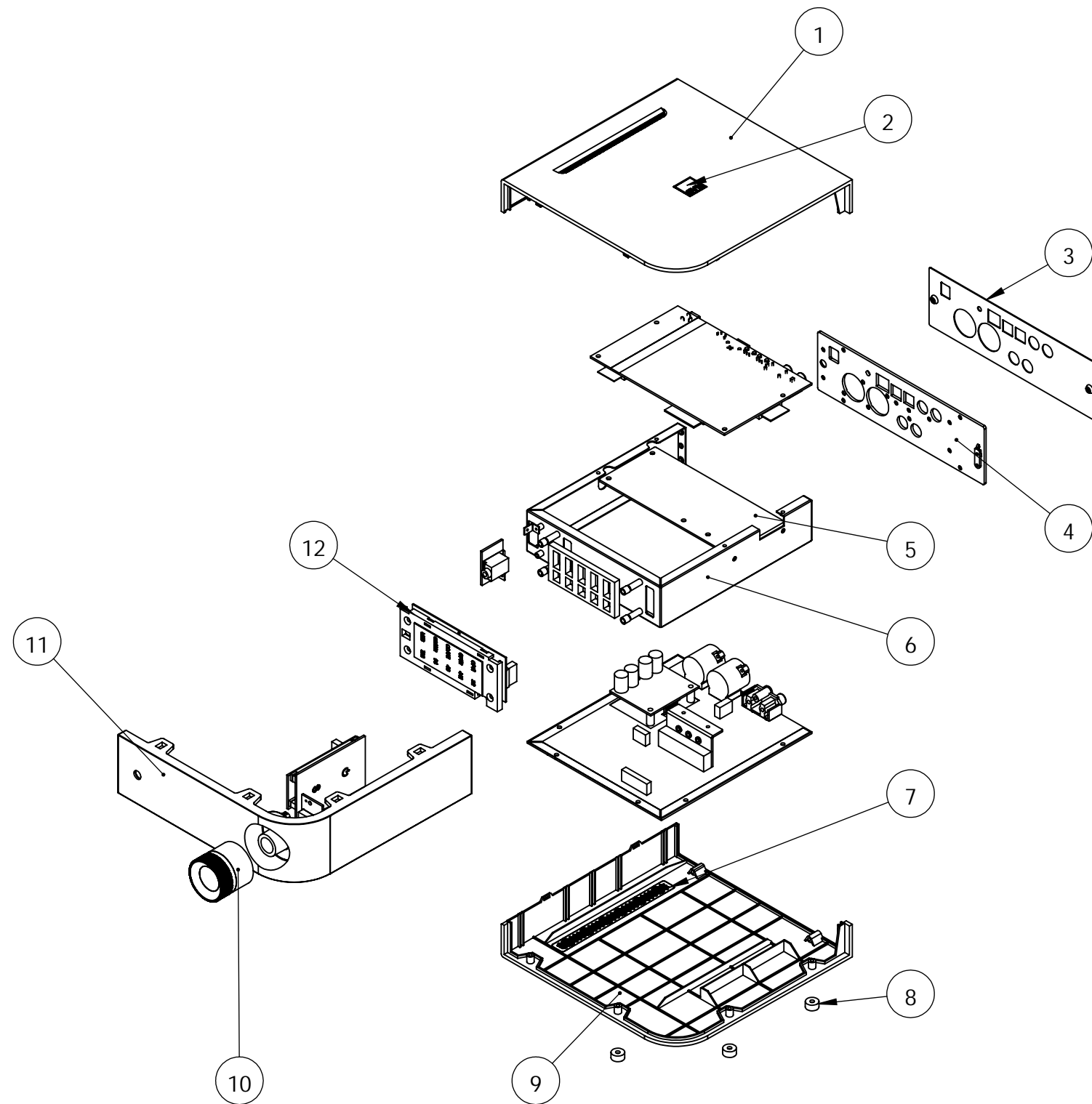

D1050 PART LIST

ITEM	PART NO.	PART NAME	QTY	REMARK
1	77-351001-1	TOP PANEL	1	
2	70-351003-1	BADGE	1	
3	67-351002-0C	REAR PLATE	1	
4	70-351002-2	INNER PLATE	1	
5	70-351004-0	HEAT SINK	1	
6	66-351003-1	U TYPE BRACKET	1	
7	66-351002-0	VENT PLATE	2	
8	75-351002-0	ROUND COVER	4	
9	77-351002-1	BOTTOM COVER	1	
10	J71-325002-0	KNOB_SEC	1	
11	76-351001-0B	FROTN PANEL	1	
12	75-351001-0	LED BRACKET	1	

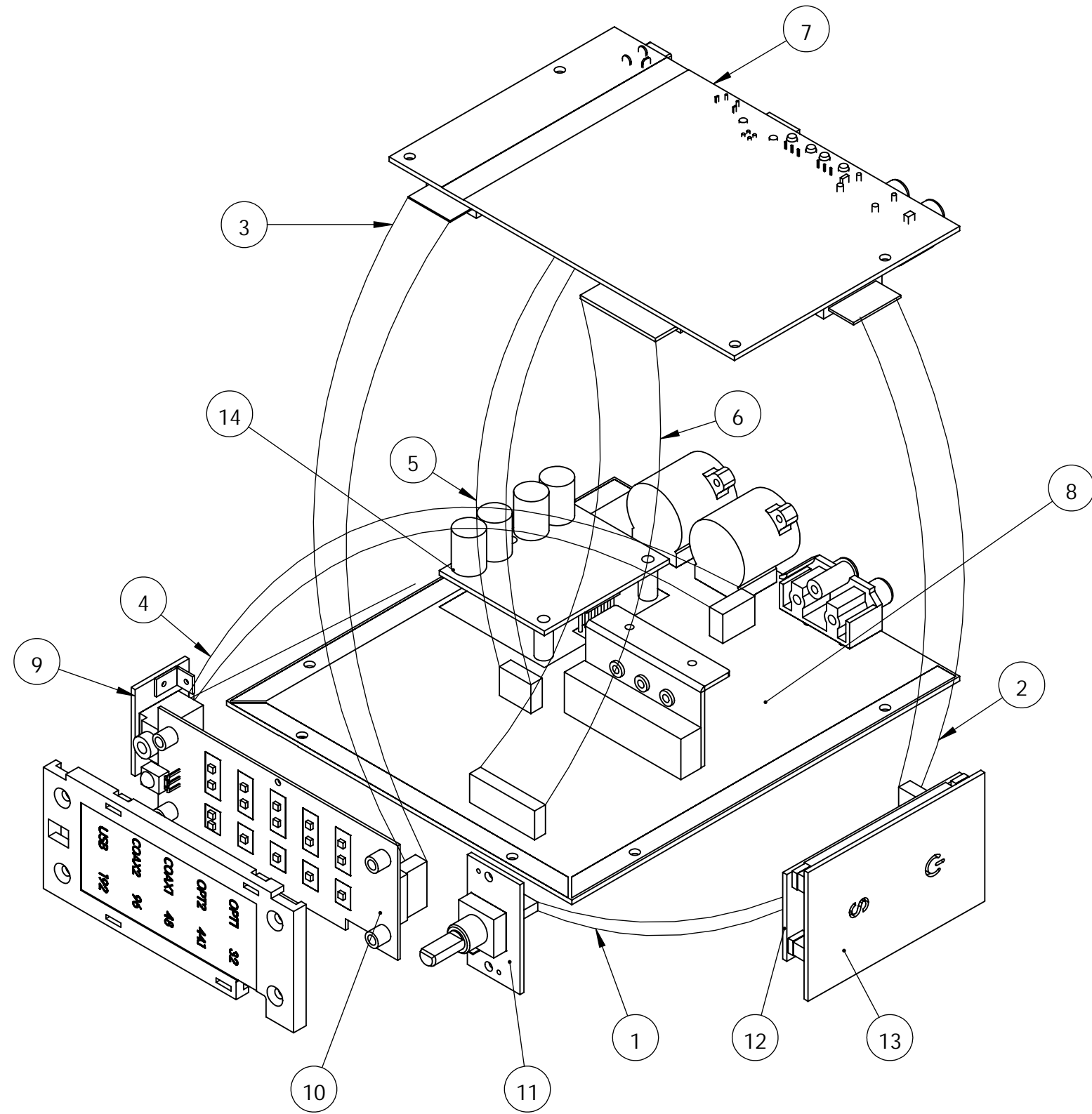

ITEM	PN.	NAME
1	14-04306-00	
2	14-40510-00	
3	14-40514-00	
4	14-40505-00	
5	14-40504-00	
6	14-40534-00	
7	01-40502-00	MAIN BOARD
8	01-40501-00	DAC BOARD
9	01-40506-00	HP-CKX BOARD
10	01-40503-01	FPP BOARD
11	01-40509-00	ENCODER BOARD
12	01-40504-00	TOUCH B BOARD
13	02-40508-00	TOUCH A BOARD
14	01-40505-00	HPAMP BOARD

CIRCUIT DIAGRAMS

1.DAC BOARD VM1.0

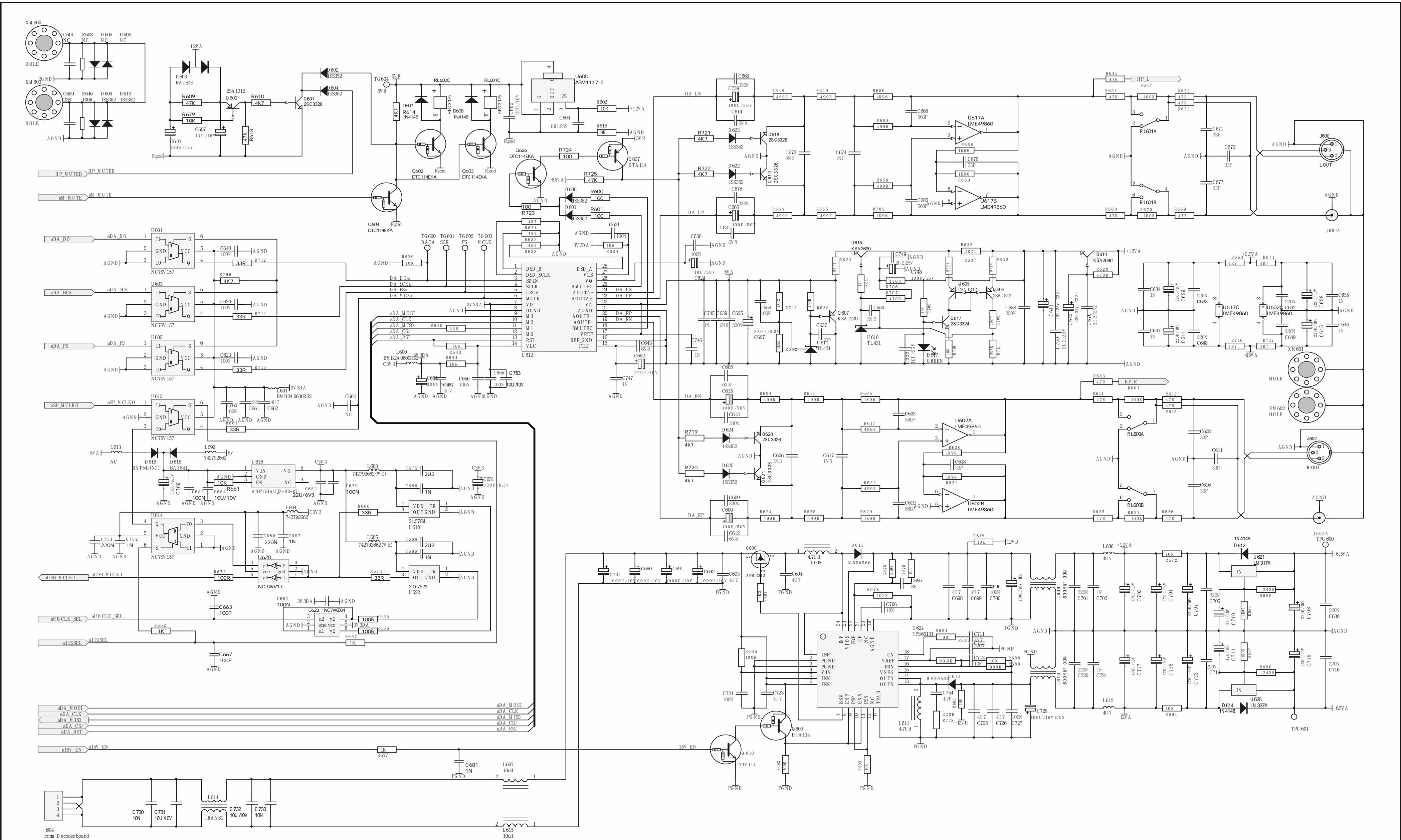

2. HPAMP BOARD VM1.0 AND HP-CKX BOARD VM1.0

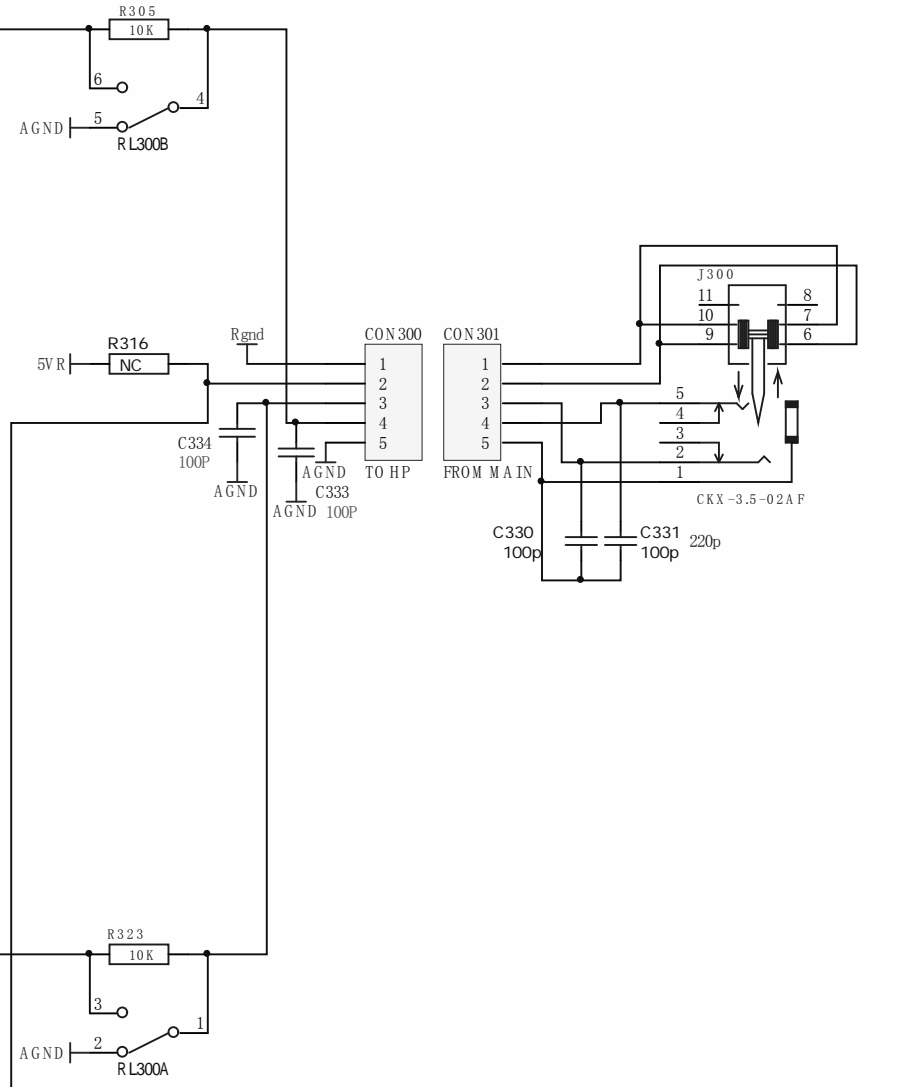
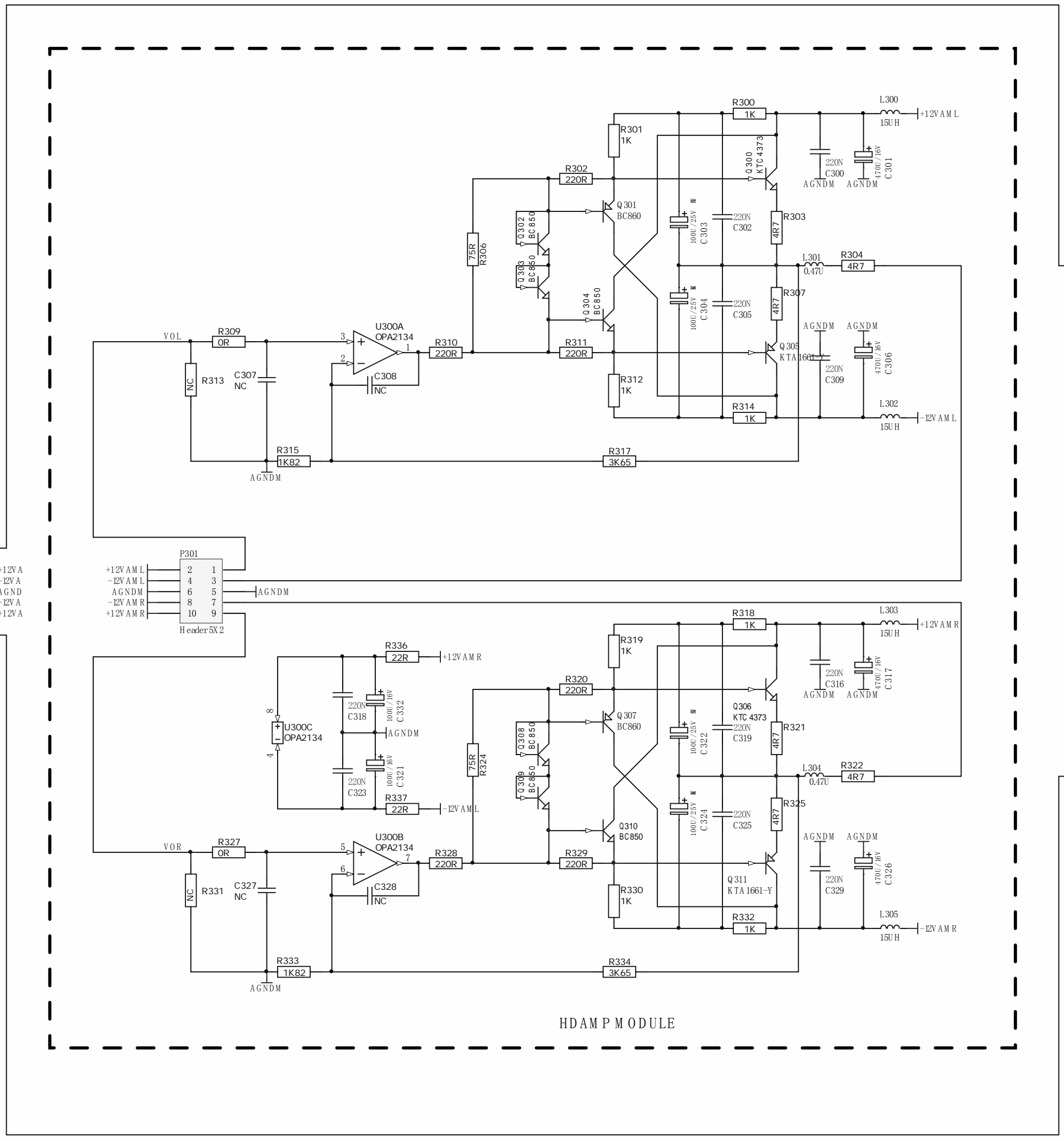
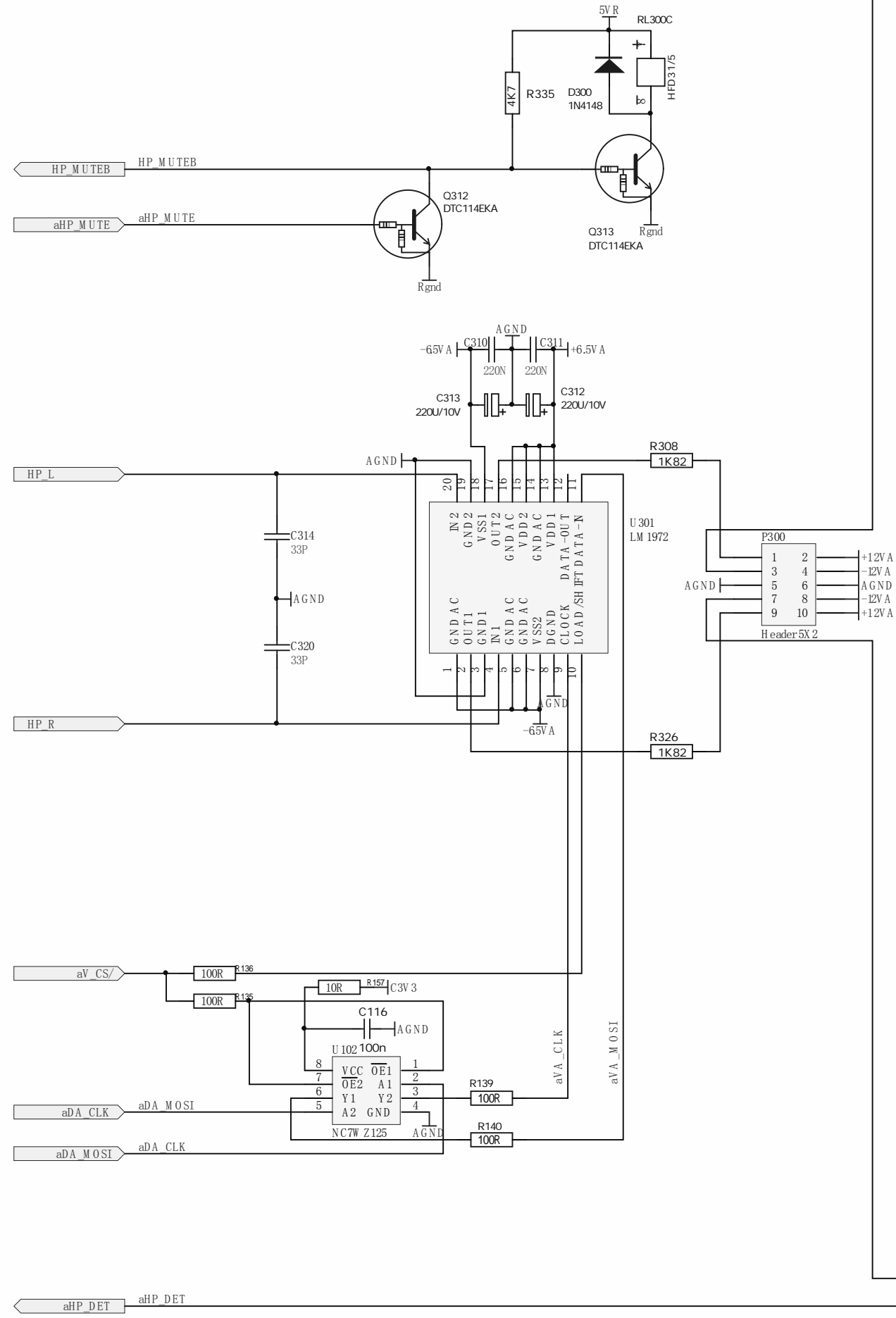



3.MAIN BOARD VM1.0(1/3)

MAIN\_MCU VM1.0

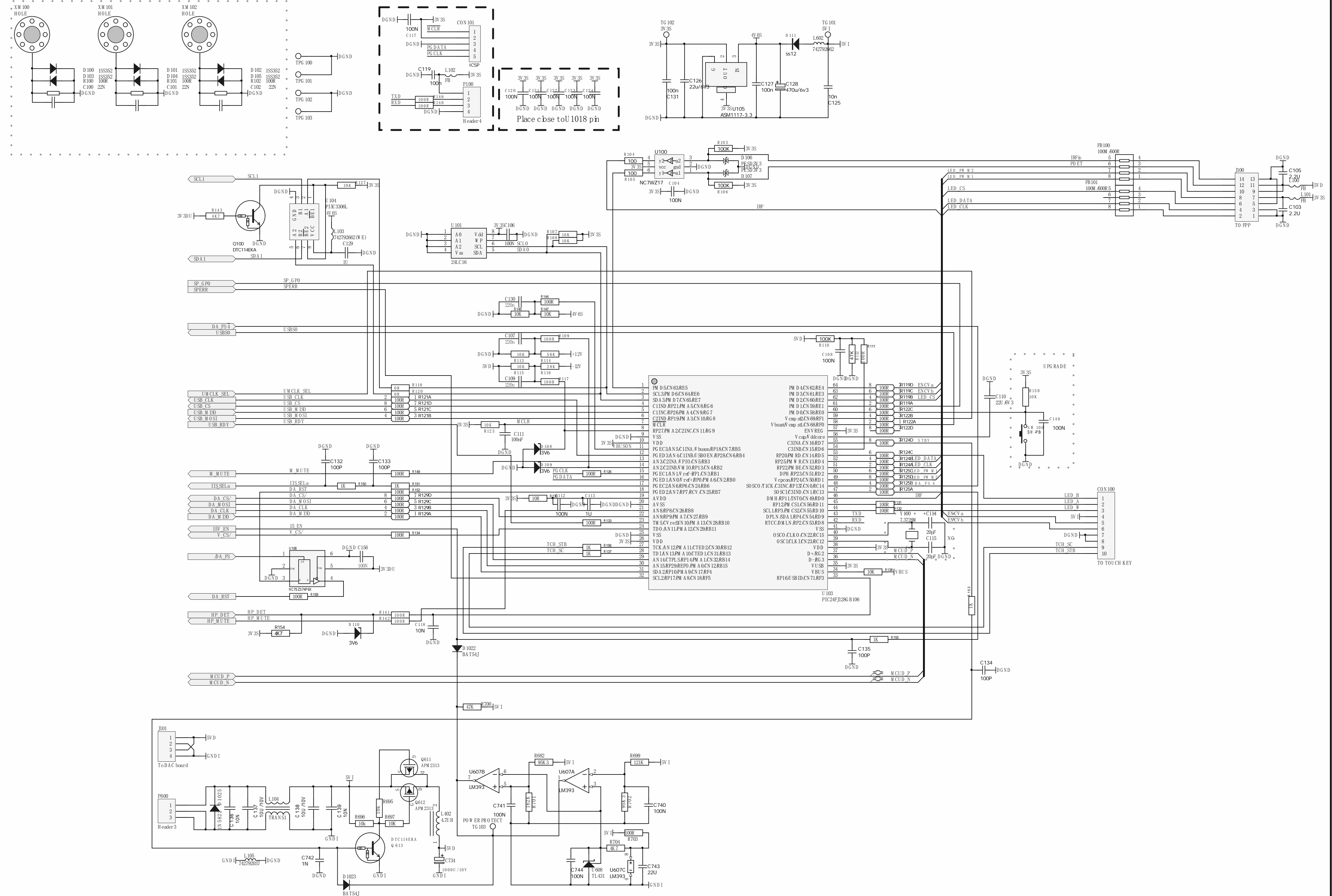

3.MAIN BOARD VM1.0(2/3)

MAIN\_SPDIF VM1.0

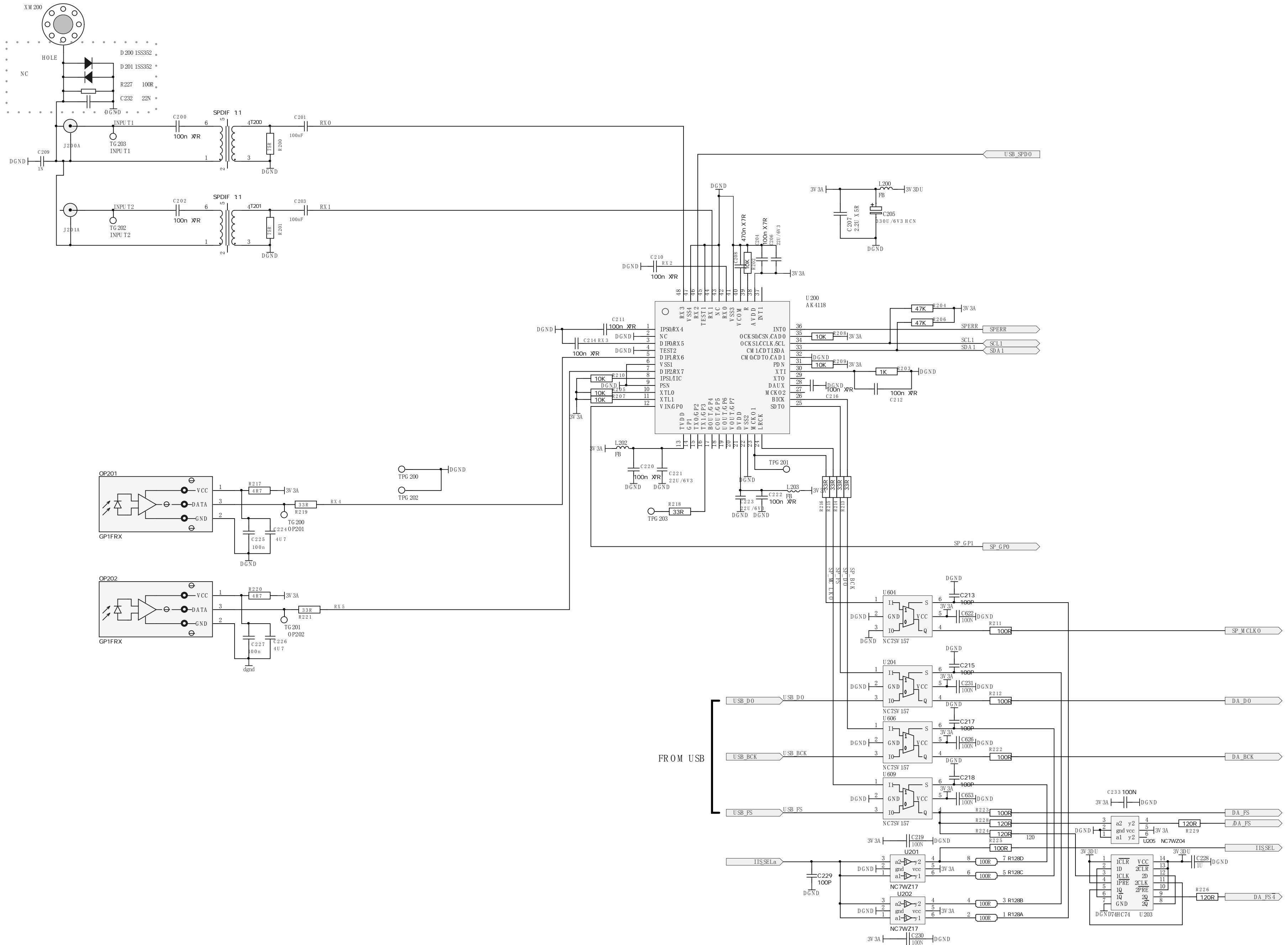

3.MAIN BOARD VM1.0(3/3)

MAIN\_USB VM1.0

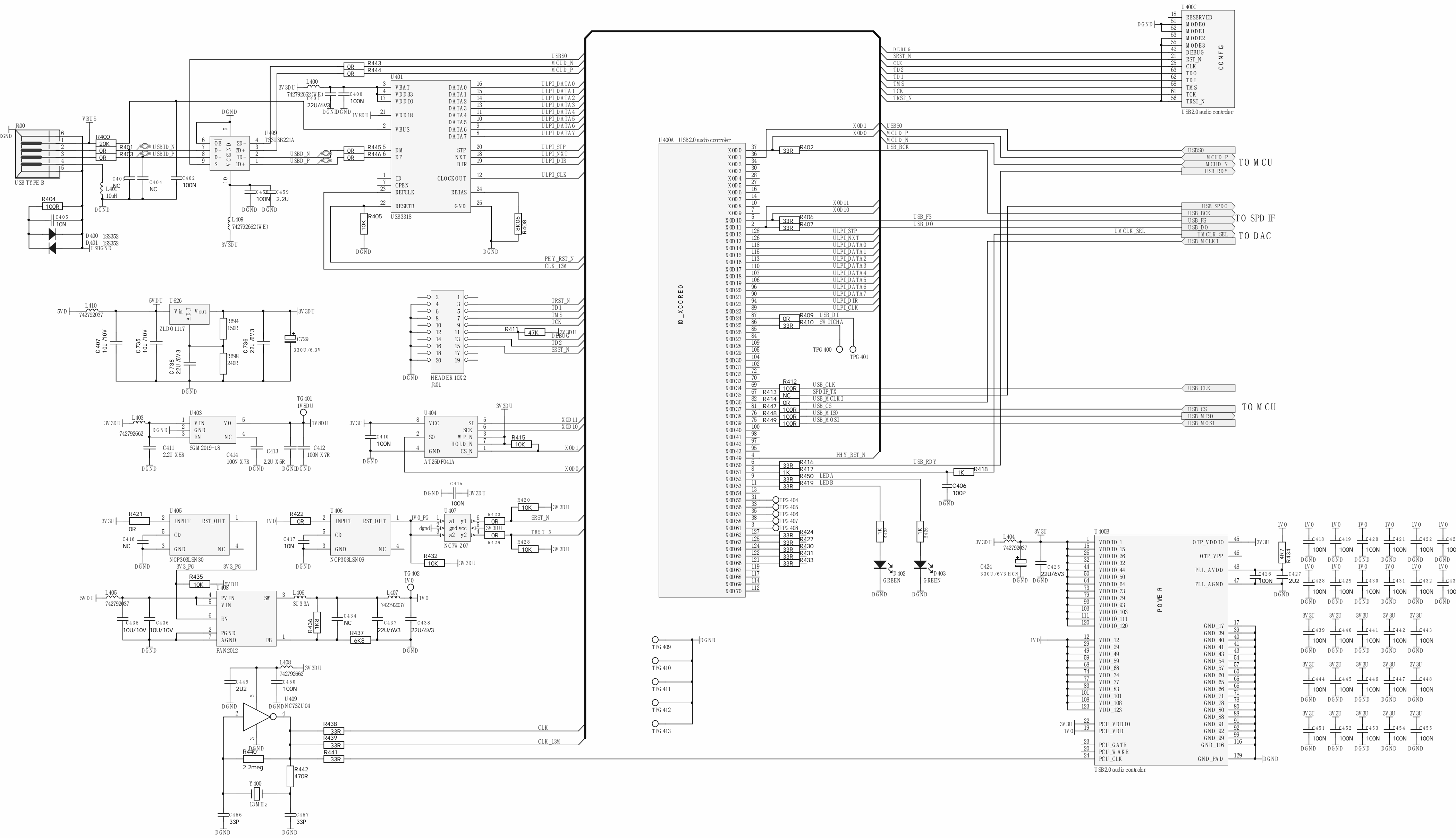

4.FPP BOARD VM1.0

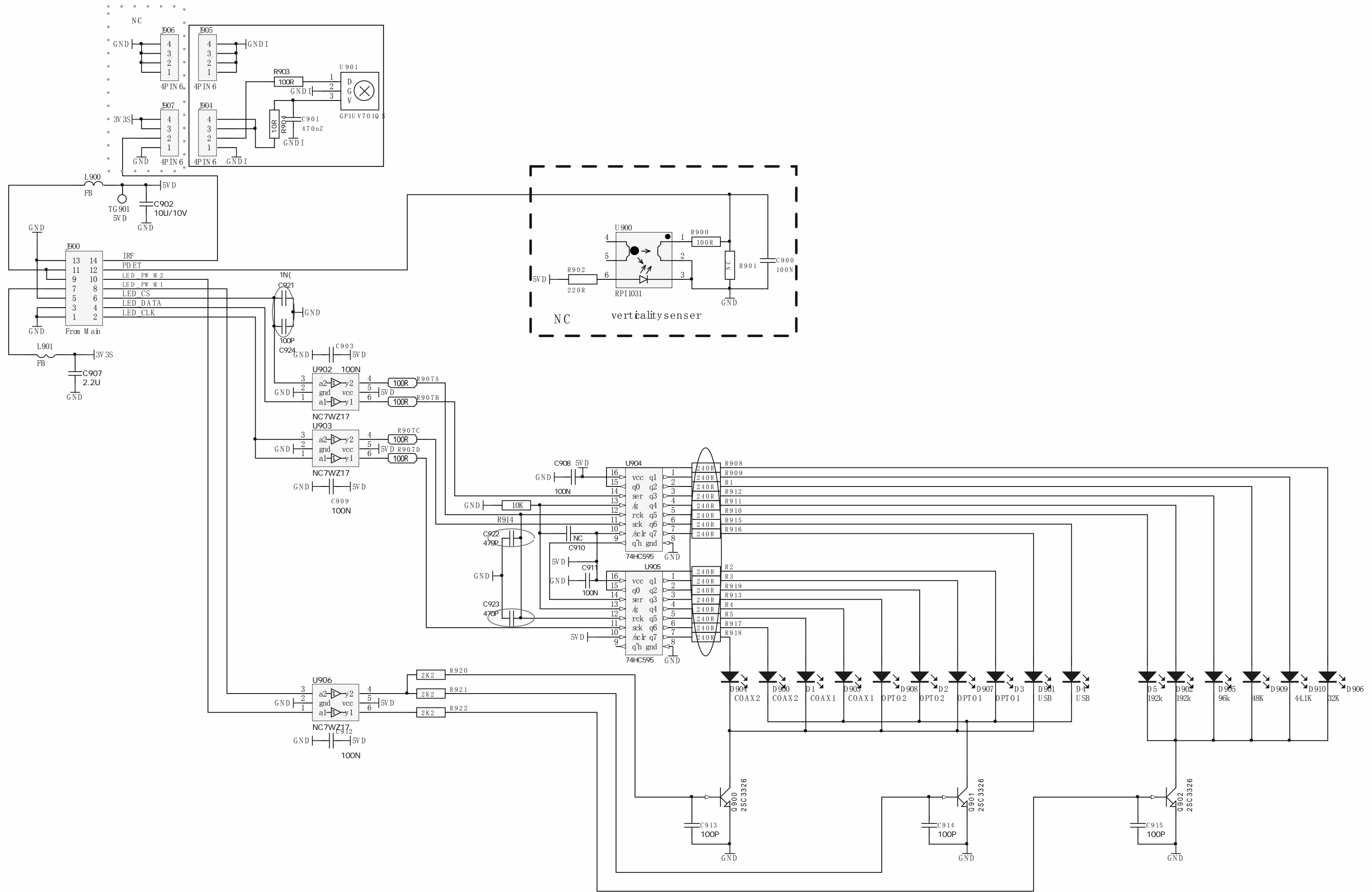

5. ENCODE BOARD VM1.0

TOUCH A BOARD VM1.0 AND TOUCH B BOARD VM1.0

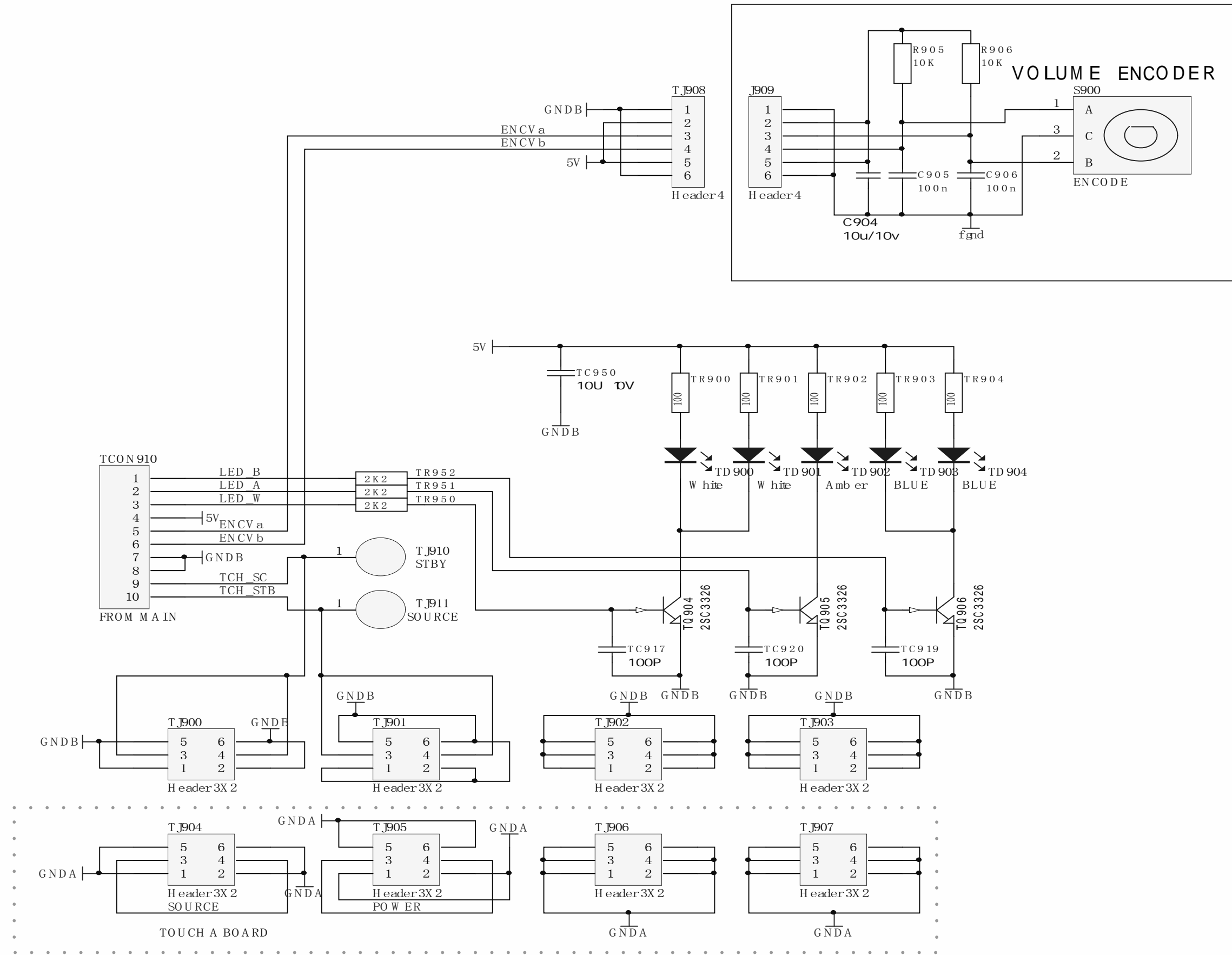

# PCB LAYOUT

## 1.DAC BOARD VM1.0

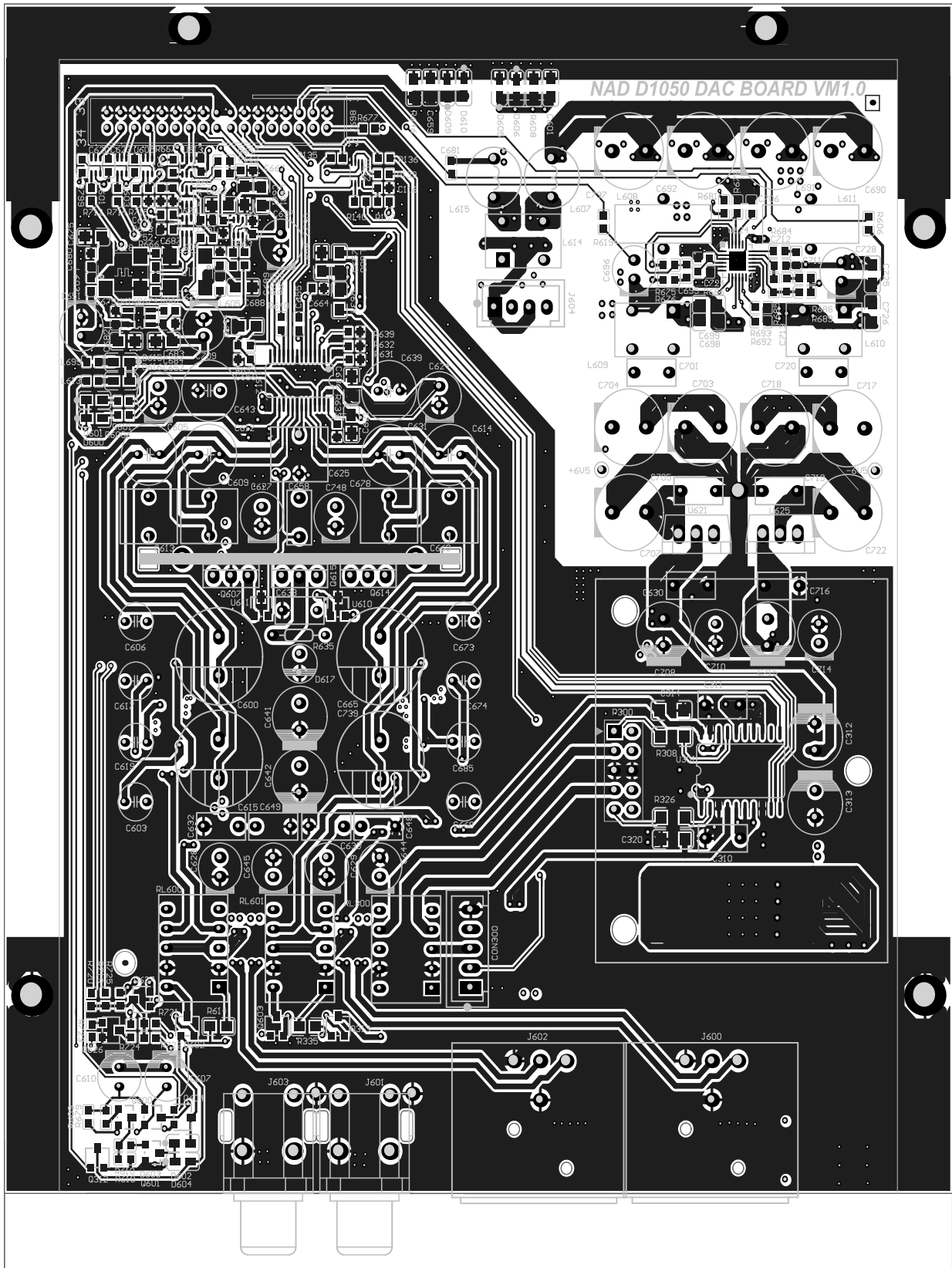

Top Layer

# 1.DAC BOARD VM1.0

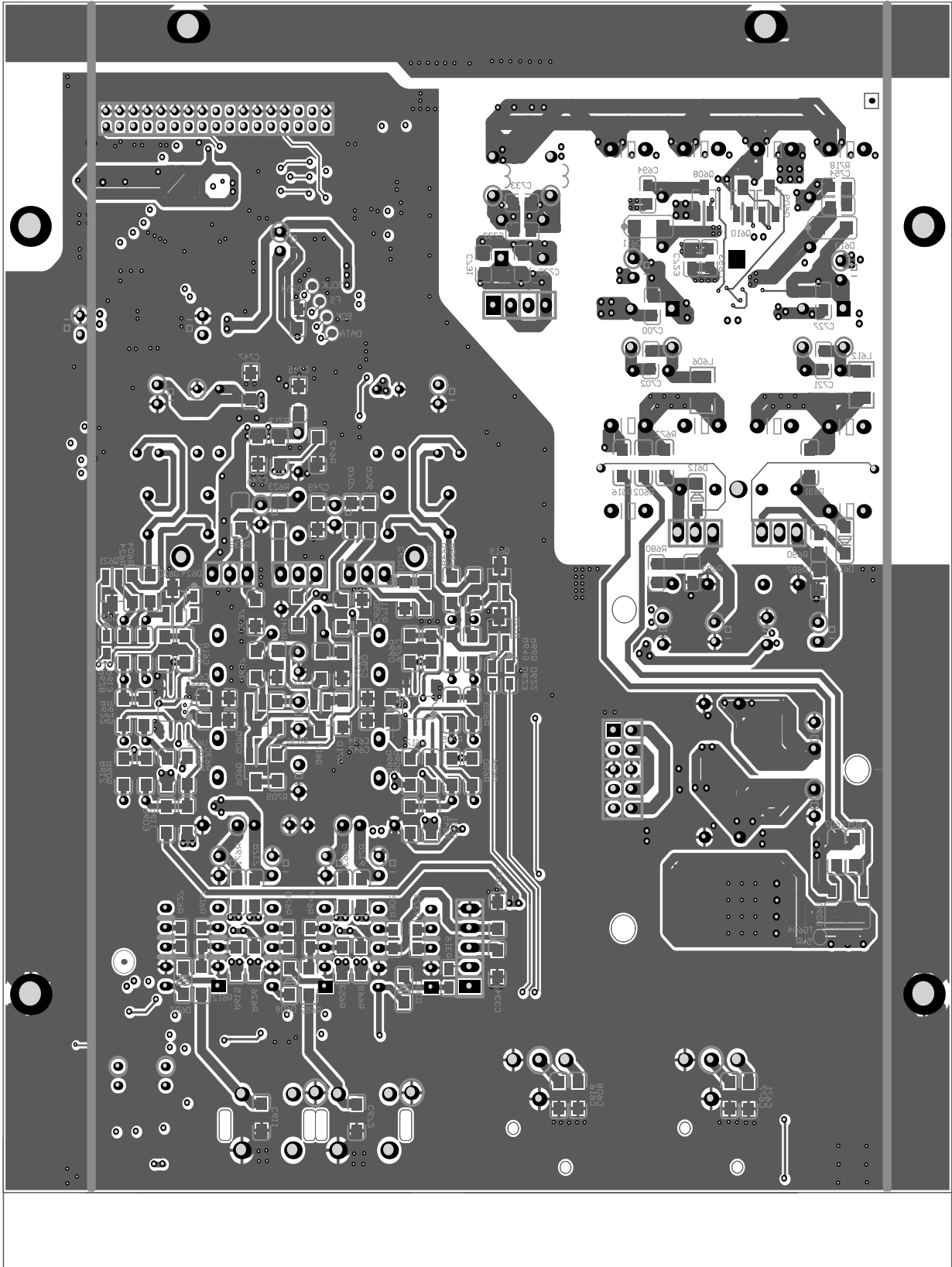

Bottom Layer

## 2.HPAMP BOARD VM1.0

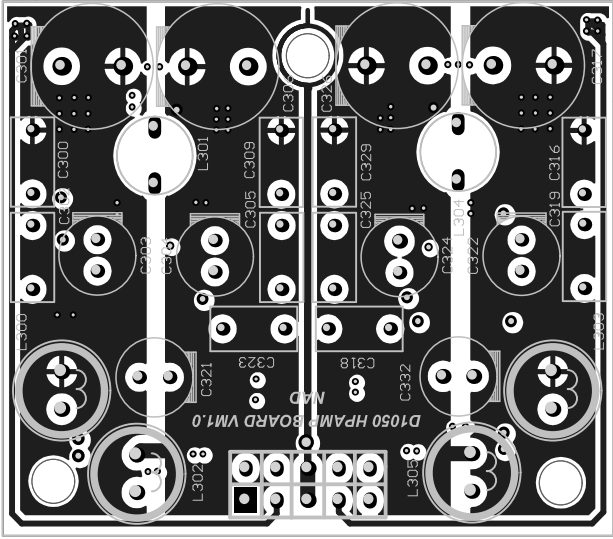

Top Layer

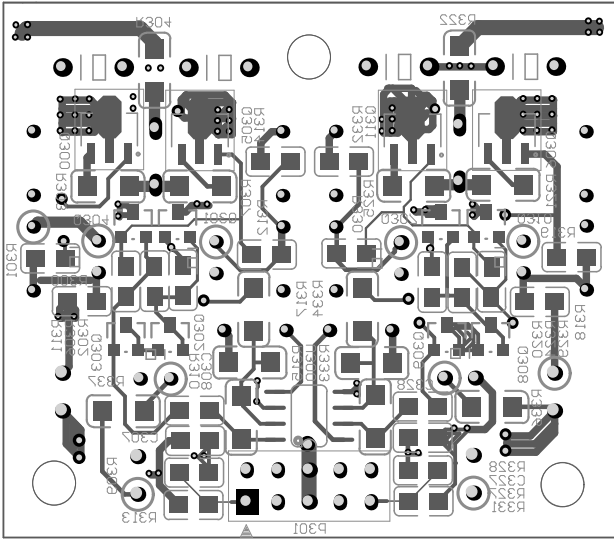

Bottom Layer

## 3.HP-CKX BOARD VM1.0

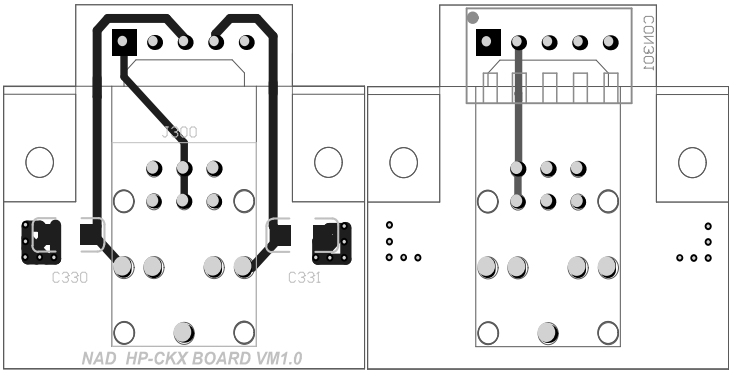

Top Layer

Bottom Layer



# 4.MAIN BOARD VM1.0

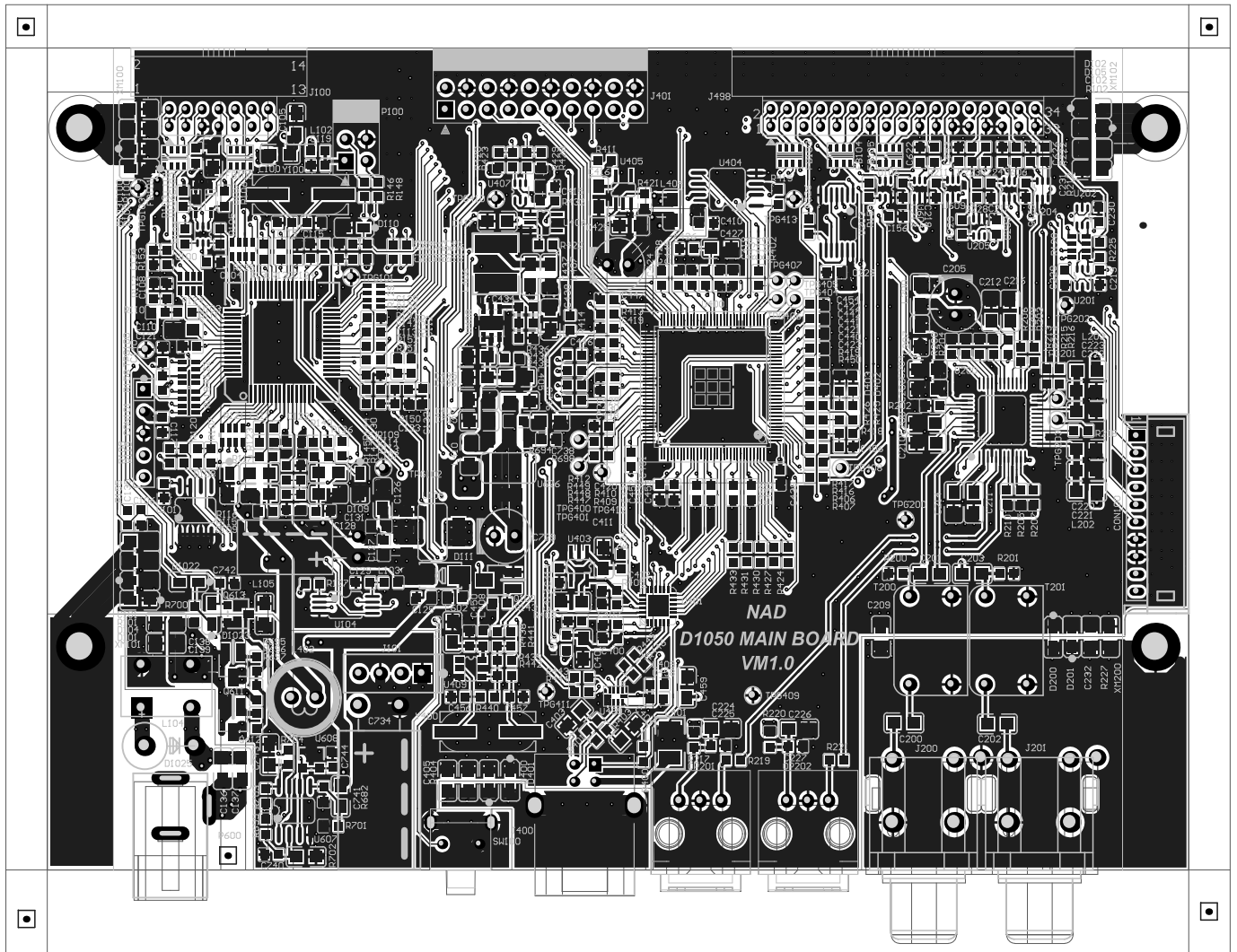

Top Layer

# 4.MAIN BOARD VM1.0

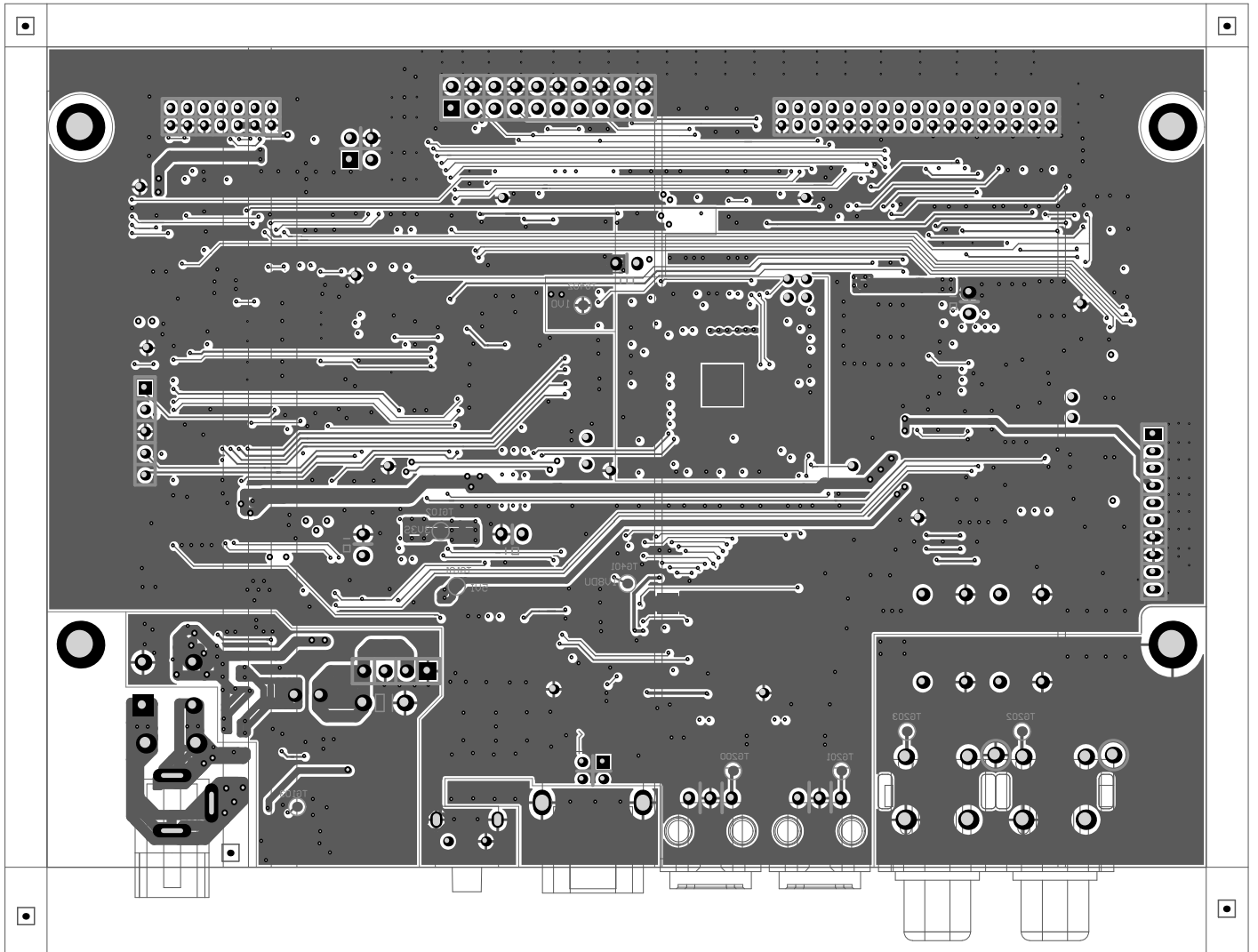

Bottom Layer





# 8.TOUCH B BOARD VM1.0

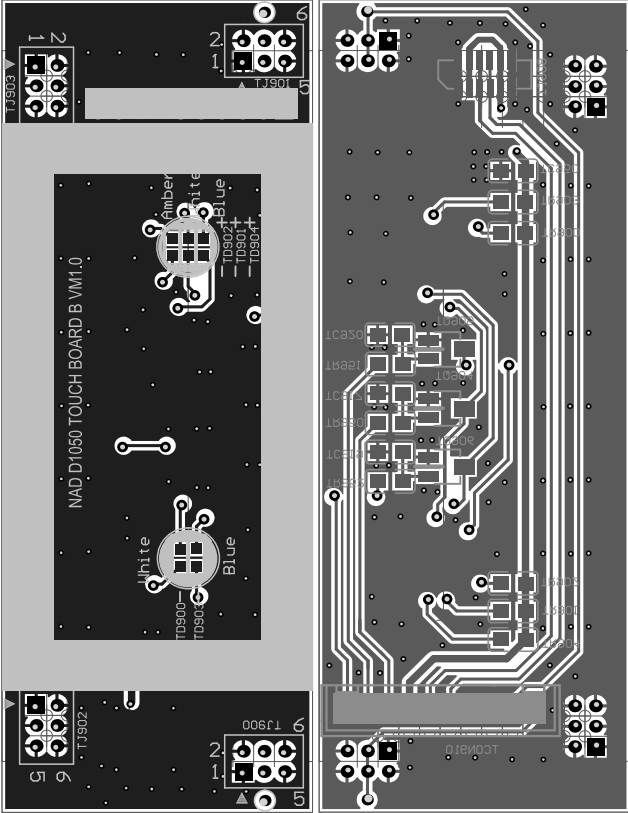

Top Layer

Bottom Layer

# ELECTRICAL PARTS LIST

<b>PCB-1:DAC BOARD</b>			
<b>CIRCUIT NO.</b>	<b>PART NO.</b>		<b>DESCRIPTION</b>
	<b>PCB INFO</b>		
	A16-40501-21	DAC PCB	VM1.0,FR-4,1.6mm,183.5mmX105mm
	<b>DIODES</b>		
D600, D601, D602, D604, D609, D610, D622, D623, D624, D625	33-40352-01	Switch Diode SMD	1SS352
D603	33-40054-00	Schottky Diode	BAT54S, SOT23
D300, D607, D608, D612, D614	33-44148-17	Switch Diode SMD	1N4148W-NR
D611, D613	33-30560-01	DIODE SCHOTTKY	MBR0560-TP
D615	33-40054-02	Schottky Rectifier Diode	BAT54J
	<b>TRANSISTORS</b>		
Q312, Q313, Q602, Q603, Q604, Q610, Q626	31-00114-05	Digital transistor	DTC114EKA
Q609, Q627	31-00114-01	Digital transistor	DTA114,SOT23,Tape
Q608	31-02301-01	P-CH MOSFET	APM2301
Q600, Q605, Q606	31-01312-00	Transistor	2SA1312GR(TE85L,F) TO-236MOD
Q601, Q618, Q619, Q620, Q621	31-03326-01	Transistor	2SC3326-A(TE85L,F), SC-59
Q617	31-03324-00	Transistor	2SC3324-GR(TE85L,F) TO-236MOD
Q614, Q615	31-02690-00	Transistor	KSC2690AYS TO-126
Q607	31-01220-00	Power Transistor	KSA1220AYS,TO-126
	<b>ICS</b>		
U102	03-07125-02	Buffer	NC7WZ125K8X
U612	03-04398-01	DAC	CS4398-CZZ
U620	03-07017-01	dual schmitt, high z when power off	NC7WV17P6X
U624	03-65131-01	Dual DC/DC convertor	TPS65131RGER
U601, U603, U605, U613, U614	03-07157-02	2:1 multiplexer	NC7SV157P6X
U623	03-00704-02	TinyLogic UHS Dual Inverter	NC7WZ04P6X
U301	03-01972-01	Audio Attenuator	LM1972M
U600	03-01117-01	Linear Regulator	AMS1117-5.0
U602, U617	03-49860-01	Dual OPAMP	LME49860MA/NOPB
U616	03-00151-33	Ragulator	ADP151AUJZ-3.3-R7
U610, U611	03-00431-05	Shunt Regulator	TL431CDBZR
U625	03-00337-00	Ragulator	LM337T TO-220
U621	03-00317-00	3-Terminal Adjustable Regulator	LM317T
	<b>RESISTORS</b>		
R684	07-90000-00	Chip Resistor	0Ω, 0603, ±5%
R681	07-90339-00	Chip Resistor	3.3Ω,0603,1/10W,±5%,RC0603JR-073R3L
R157	07-90100-00	Chip Resistor	10Ω,0603,1/10W,±5%,RC0603JR-0710RL
R640, R666, R667, R674, R712, R714, R715	07-90330-00	Chip Resistor	33Ω,0603,1/10W,±5%,RC0603JR-0733RL
R135, R136, R139, R140, R600, R601, R655, R656, R673, R686, R723, R724	07-90101-00	Chip Resistor	100Ω,0603,1/10W,±5%,RC0603JR-07100RL
R657, R662, R677	07-91001-00	Chip Resistor	1KΩ,0603,1/10W,±1%,RC0603FR-071KL
R610	07-94701-00	Chip Resistor	4.7KΩ,0603,1/10W,±1%,RC0603FR-074K7L
R631, R632, R633, R719, R720, R721, R722, R799	07-90472-00	Chip Resistor	4.7KΩ,0603,1/10W,±5%,RC0603JR-074K7L
R639, R643, R661, R676, R679, R688, R693, R619, R606	07-90103-00	Chip Resistor	10KΩ,0603,1/10W,±5%,RC0603JR-0710KL
R609, R618, R725	07-94702-00	Chip Resistor	47KΩ,0603,1/10W,±1%,RC0603FR-0747KL
R685	07-99092-00	Chip Resistor	90.9KΩ,0603,1/10W,±1% RC0603FR-0790K9L
R692	07-90104-00	Chip Resistor	100KΩ,0603,1/10W,±5%,RC0603JR-07100KL
R678	07-91023-00	Chip Resistor	102K,0603,1/10W,±1%,RC0603FR-07102KL
R675, R689	07-99093-00	Chip Resistor	909K,0603,1/10W,±1%,RC0603FR-07909KL

R634, R644	07-90100-01	Chip Resistor	10Ω,0805,1/8W,±5%,RC0805JR-0710RL
R646	07-90101-01	Chip Resistor	100Ω,0805,1/8W,±5%,RC0805JR-07100RL
R718	07-90221-01	Chip Resistor	220Ω,0805,1/8W,±5%,RC0805JR-07220RL
R680, R690	07-92430-01	Chip Resistor	243Ω,0805,1/8W,±1%,RC0805FR-07243RL
R683, R687	07-91051-01	Chip Resistor	1.05KΩ,0805,1/8W,±1%
R614	07-94701-01	Chip Resistor	4.7KΩ,0805,1/8W,±1%,RC0805FR-074K7L
R335	07-90472-01	Chip Resistor	4.7KΩ,0805,1/8W,±5%,RC0805JR-074K7L
R305, R323	07-91002-01	Chip Resistor	10KΩ,0805,1/8W,±1%,RC0805FR-0710KL
R607, R627, R647, R670	07-91003-01	Chip Resistor	100KΩ,0805,1/8W,±1%,RC0805FR-07100KL
R671, R663, R716, R717	07-94708-02	Chip Resistor	4.7Ω,1206,1/4W,±1%,RC1206FR-074R7L
R637	07-92219-02	Chip Resistor	22.1Ω,1206,1/4W,±1%,RC1206FR-0722R1L
R638	07-91000-02	Chip Resistor	100Ω,1206,1/4W,±1%,RC1206FR-07100RL
R709	07-92200-02	Chip Resistor	220Ω,1206,1/4W,±1%,RC1206FR-07220RL
R636	07-92210-02	Chip Resistor	221Ω,1206,1/4W,±1%,RC1206FR-07221RL
R706, R707	07-94700-02	Chip Resistor	470Ω,1206,1/4W,±1%,RC1206FR-07470RL
R708	07-92001-02	Chip Resistor	2KΩ,1206,1/4W,±1%,RC1206FR-072KL
R616	07-90000-92	Chip Resistor	MMF204FRE0R,0Ω,0.4W,±1%
R623	07-92218-92	Chip Resistor	MELF0204,2.21Ω,1/4W,±1%
R602, R672, R691	07-91009-92	MELF Resistors	MMF204FRE10R,10Ω,1/4W,±1%
R603, R611, R612, R615, R625, R626, R645, R651, R652, R653, R668, R669	07-94709-92	MELF Resistors	MMF204FRE47R, 47Ω, ±1%
R620	07-94700-92	MELF Resistors	MMF204FRE470R,470Ω,1/4W,±1%
R604, R613, R617, R622, R624, R628, R648, R649, R654, R659, R664, R665	07-94990-92	MELF Resistors	MMF204FRE499R,499Ω,1/4W,±1%
R605, R621, R629, R630, R650, R658, R660, R705	07-91961-92	MELF Resistors	MELF0204,1.96KΩ,1/4W,±1%
R308, R326, R642, R713	07-91821-92	MELF Resistors	MELF0204,1.82KΩ,1/4W,±1%
R641	07-91001-92	MELF Resistors	MMF204FRE1K,1KΩ,1/4W,±1%
R711	07-92551-92	MELF Resistors	MELF0204,2.55KΩ,1/4W,±1%
R710	07-91002-92	MELF Resistors	MMF204FRE10K,10KΩ,1/4W,±1%
	<b>CAPACITORS</b>		
C695	26-80951-00	Ceramic Capacitor SMD	8pF,50V,0603,NPO,CC0603CRNP09BN8R0
C713	26-10051-00	Ceramic Capacitor SMD	10pJ,50V,0603,NPO,C1608C0G1H100JT
C663, C667	26-10151-00	Ceramic Chip Capacitor	100pF,50V,0603,NPO
C680, C681, C687, C689, C752	26-10251-10	Ceramic Chip Capacitor	1N,50V,NPO,0603
C711	26-47251-00	Ceramic Chip Capacitor	4n7K,50V,0603,X7R
C706	26-10351-00	Ceramic Chip Capacitor	10nK,50V,0603,X7R,C2012X7R1H103KT
C116, C620, C623, C660, C724, C640, C655, C656, C679, C683, C697	26-10411-00	Ceramic Chip Capacitor	100nF,16V,0603, X7R
C686, C712, C751	26-22411-10	Ceramic Chip Capacitor	220nF,16V, X7R, 0603
C754	26-47951-01	Ceramic Capacitor SMD	4.7PJ,50V,0805,NPO,C2012C0G1H4R7JT
C702, C721	26-10212-01	Ceramic Chip Capacitor	1nJ,100V,0805,NPO
C730, C733	26-10351-01	Ceramic Chip Capacitor	10nK,50V,0805,X7R
C659	26-22312-01	Ceramic Chip Capacitor	22nF,100V,0805, X7R
C621, C636, C700, C727	26-10451-41	Ceramic Chip Capacitor	0.1uF,50V,5%,X7R,0805,C0805X104J050T
C675, C688	26-22521-01	Ceramic Chip Capacitor	2.2uF,±10%,25V,X5R,0805
C657, C662, C693, C694, C723	26-47511-01	Ceramic Chip Capacitor	4.7uF, 16V, X5R,0805
C698, C699, C725, C726	26-47521-11	Ceramic Capacitor SMD	4.7uK,25V,X5R,0805,C2012X5R1E475KTJ00E

C684, C731, C732, C753	26-10611-01	Ceramic Chip Capacitor	10uF,0805,10V,C0805C106M8PACTU/C2012X5R1A106M
C661 C682	26-22660-11	Ceramic Chip Capacitor	22uF, 6.3V, X5R, 0805
C314, C320, C608, C611, C616, C618, C637, C671, C672, C676, C677	26-33052-02	Ceramic Chip Capacitor	1206, 33pF, 500V, NPO, ±5%
C333, C334	26-10151-02	Ceramic Chip Capacitor	100pJ,50V,1206,NPO
C634, C635, C646, C647, C745, C746, C747	26-10222-12	Ceramic Chip Capacitor	1nJ,200V,1206,NPO
C604, C666	26-10621-12	Ceramic Chip Capacitor	10uF, 25V, X5R, 1206, C3216X5R1E106KT
C650	26-22251-12	Ceramic Chip Capacitor	2.2nJ,50V,1206,NPO,C3216C0G1H222J
C670, C749, C750	26-22551-02	Chip Capacitor	2.2uK,50V,1206,X7R,CC1206KKX7R9BB225
C602	26-22611-02	Chip Capacitor	22uM,10V,1206,X5R,C3216X5R1A226MT
C609, C613, C625, C669, C678	25-33412-04	Metallize Polypropylene Capacitor	MKP2,330nF / 100V
C603, C619, C668, C685	25-56161-00	Metallized polystyrene Film Capacitor	ASS21,560P,±5%, 63/100V
C617, C674	25-15261-01	Metallized polystyrene Film Capacitor	ASS21,1500P,±5%, 63/100V
C605, C612, C614, C631, C639, C643	25-68212-04	Polypropylene Film Capacitor	ASS21,6.8nF,100V,±5%
C606, C673	25-33261-00	Polypropylene Film Capacitor	ASS21,3.3nF,100V,±5%
	76-000001-0	Teflon	18AWG-L
C310, C311, C630, C632, C633, C638, C648, C649, C701, C705, C716, C719, C720	25-22451-00	Polypropylene Film Capacitor	CL23B-50V-224K R5
C658	25-10412-04	Metallized Polyester Film Capacitor	CL23B-100V-104JR, C242A104J20A201
C748	06-10111-05	Alu Electrolytic Capacitor	CD263,100uF,16V,±20%,105 °C, F2.5
C703, C704, C707, C717, C718, C722	06-47111-18	Alu Electrolytic Capacitor	470uF,16V,±20%,105 °C, UPW1C471MPD,Pitch=5mm 10*12.5mm
C607	06-47011-03	Alu Electrolytic Capacitor	CD263(X),47uF,16V,±20%,F2.5
C696, C728	06-10111-48	Alu Electrolytic Capacitor	ULR107M1CE08RR,100uF,16V, ±20%,105 °C, F2.5
C600, C615, C665, C739	06-10151-14	Alu Electrolytic Capacitor	UKZ1H101MHM,100uF,50V,±20%,85 °C
C624	06-10051-20	Alu Electrolytic Capacitor	10uF,50V,±20%,105 °C, EEUFC1H100L(H)
C610	06-10121-14	Alu Electrolytic Capacitor	EEUFC1E101SH,100uF,25V,±20%,105 °C
C710, C714	06-47011-16	Alu Electrolytic Capacitor	47uF,16V,±20%,85 °C, ECEA1CKS470(I)
C312, C313, C708, C715	06-22111-27	Alu Electrolytic Capacitor	220uF,10V,±20%,85 °C, ECEA1AKA221
C628, C629, C644, C645, C652	06-22111-25	Alu Electrolytic Capacitor	UFW1A221MEDTD, 220uF, 10V, ±20%, 85 °C
C627, C654, C651, C709	06-33160-10	Alu Electrolytic Capacitor	ULR337M0JE08TU, 330uF, 6.3V, ±20%, 105 °C, F2.5
C641, C642	06-22121-12	Alu Electrolytic Capacitor	220uF,25V,±20%,105 °C, EEUFC1E221
C690, C691, C692, C737	06-10211-12	ALU Electrolytic CAP	EEUFC1A102B,1000uF,10V,±20%,105 °C
	<b>INDUCTANCE</b>		
L603, L605, L604, L699	08-04102-31	Chip Ferrite Bead	742792662, 1000ohm @ 100MHz, I <sub>max</sub> =600mA
L600, L601	08-04601-05	Ferrite Chip	600ohm @ 100MHz 2A MPZ2012S601A
L606, L612	08-04181-03	Ferrite Bead SMD	180R/100MHz,3A,1210,CBW322513U181T
L608, L611	08-01509-00	Inductor	5uH, ±30%, T44-2
L608, L611	J19-00442-00	Ferrite Ring	T44-2
L609, L610, L614	08-05550-00	Resonance Inductor	T9*5*3-55uH
L607, L615	08-02100-07	Filter Choke	10uH, 2.6A,744772100
	<b>CRRSTAL</b>		
U618	04-22452-09	Oscillator	SRTD3T-24.576MHZ TR
U618	or 04-22452-06	VCXO	24.576MHz, C3391-24.576MHz,SMD 5*7
U622	04-22252-05	Oscillator	SRTD3T-22.5792MHZ TR
U622	or 04-22252-03	VCXO	22.5792MHz, C3398-22.579200MHz,SMD 5*7
	<b>CONNECTORS</b>		



R635	07-22218-01	Metal Film Resistor	RJ13, 2.21Ω, 1/6W, ±1%, Pitch=7.5mm
D617	33-50550-00	LED (Green)	L-513GD
RL300, RL600, RL601	12-02202-15	SIGNAL RELAY	HFD31 5V
J698	13-22034-00	Connector Socket	2.0mm, 2x17Pin, CNT-B200-2*17-GS-2.8-N
P300	13-22510-09	Connector	CNT-F254-2*5-GS-850-N, 2.54, 2x5Pin
CON300	13-22505-03	Housing	XH 2.5A-5A
	85-048001-0	PCB Spacer	LCI-11
(J601, J603)	17-01002-04	RCA	AV2-8.4-14
J600, J602	J17-09103-13	Mic Connector	NC3MAAH
J604	13-22504-00	Connector	XHB 2.5A-4A
<b>PCB-2:HPAMP BOARD</b>			
<b>CIRCUIT NO.</b>	<b>PART NO.</b>		<b>DESCRIPTION</b>
	<b>PCB INFO</b>		
	A16-40505-21	HPAMP PCB	VM1.0,FR-4,1.6mm,,TG130
	<b>TRANSISTORS</b>		
Q305, Q311	31-01661-00	Transistor	KTA1661-Y
Q300, Q306	31-04373-00	Transistor	KTC4373-Y
Q301, Q307	31-00860-00	Transistor	BC860B,215
Q302, Q303, Q304, Q308, Q309, Q310	31-00850-02	Transistor	BC850B,215
	<b>ICS</b>		
U300	03-02134-00	运放	OPA2134UA
	<b>RESISTORS</b>		
R317, R334	07-93651-92	Chip Resistor	MELF0204,3.65KΩ,1/4W,±1%
R336, R337	07-92209-02	Chip Resistor	22Ω,1206,1/4W,±1%,RC1206FR-0722RL
R306, R324	07-90750-01	Chip Resistor	75Ω,0805,1/8W,±5%,RC0805JR-0775RL
R302, R310, R311, R320, R328, R329	07-90221-01	Chip Resistor	220Ω,0805,1/8W,±5%,RC0805JR-0722ORL
R300, R301, R312, R314, R318, R319, R330, R332	07-91001-01	Chip Resistor	1KΩ,0805,1/8W,±1%,RC0805FR-0711KL
R315, R333	07-91821-92	MELF Resistors	MELF0204,1.82KΩ,1/4W,±1%
R303, R304, R307, R321, R322, R325	07-94708-92	MELF Resistors	MELF0204,4.7Ω,1/4W,±1%
R309, R327	07-90000-01	Chip Resistor	0Ω,0805,1/8W,±5%
	<b>INDUCTANCE</b>		
L300, L302, L303, L305	08-01150-01	Power Inductor	JP0808-150M,15uH±20%,2A
L301, L304	08-02428-00	Air Coil Inductor	R04-0.4uH
	<b>CONNECTORS</b>		
C301, C306, C317, C326	06-47111-18	Alu Electrolytic Capacitor	470uF,16V,±20%,105℃,UPW1C471MPD,Pitch=5mm 10*12.5mm
C303, C304, C321, C322, C324, C332	06-10121-14	Alu Electrolytic Capacitor	EEUFC1E101SH,100uF,25V,±20%,105℃
C300, C302, C305, C309, C316, C318, C319, C323, C325, C329,	25-22451-00	Polypropylene Film Capacitor	CL23B-50V-224K R5
P301	13-12510-14	Connector	2.54mm,2*5Pin,CNT-M254-2*5_GS-6/3-N
<b>PCB-3:HP-CKX BOARD</b>			
<b>CIRCUIT NO.</b>	<b>PART NO.</b>		<b>DESCRIPTION</b>
	<b>PCB INFO</b>		
	A16-40506-22	HP-CKX PCB	VM2.0,FR-4,1.6mm,TG130,
	A16-40560-22	HP-CKX PCB	vm2.0,FR-4,1.6mm,120.8mmX70mm
	<b>CAPACITORS</b>		
C330, C331	26-10151-02	Ceramic Chip Capacitor	100pJ,50V,1206,NPO
	<b>CONNECTORS</b>		
J300	17-02001-70	Phone Jack	CKX-3.5-02AF
	14-40505-00	wire	L=265mm
	66-359003-0	Pcb BRACKET	SECC N5 T=0.8mm
	61-022504-1	Machine screw	MB2x4
	61-022506-5	Machine Screw	MB2.5x6
<b>PCB-4:MAIN BOARD</b>			
<b>CIRCUIT NO.</b>	<b>PART NO.</b>		<b>DESCRIPTION</b>
	<b>PCB INFO</b>		
	A16-40502-23	main PCB	VM2.0,FR-4,1.6mm,,130mmX87mm
	A16-40520-23	main PCB	VM3.0,FR-4,1.6mm,,292mmX214.1mm

	<b>DIODES</b>		
D100, D101, D102, D103, D104, D105, D400, D401	33-40352-01	Switch Diode SMD	1SS352
D106, D107	33-00330-01	ESD DIODE	PESD3V3
D111	33-20014-02	Surface Mount Schottky Barrier Rectifier	SS14, 1A 40V
D108, D109, D110	33-14709-09	Zener Diode	BZT52C4V7, 4.7V, 350mW
D403, D402	33-50603-01	GREEN LED	SML-310MTT86
D1022, D1023	33-40054-02	Schottky Rectifier Diode	BAT54J
D112	33-16209-16	Zener Diode	ZMM6V2, 6.2V, 1/2W
D1025	33-25822-00	Schottky Barrier Rectifier	1N5822
	<b>TRANSISTORS</b>		
Q100, Q613	31-00114-05	Digital transistor	DTC114EKA
Q611, Q612	31-02301-01	P-CH MOSFET	APM2301
	<b>ICS</b>		
U105	03-01117-33	Linear Regulator	LM1117MPX-3.3/AMS1117-3.3
U106	03-03746-01	IC	NC7SZ374P6X, SC70-6
U100, U201, U202	03-00717-01	SCHMITT DRIVER	NC7WZ17
U205	03-00704-02	TinyLogic UHS Dual Inverter	NC7WZ04P6X
U103	03-24128-14C	MCU	PIC24FJ128GB106T-I/PT
U103	03-24128-01	MCU	PIC24FJ128GB106T-I/PT
U400	03-01128-01	MCU	XS1-L01A-TQ128-C5
U200	03-04118-01	Receiver	AK4118AEQ
U401	03-03318-01	Reference Clock	USB3318C-CP-TR
U101	03-02416-02	EEPROM	24LC16A / 24LC16BT-I/SN, SO8
U403	03-02019-18	Low Power, Low Dropout, RF - Linear Regulators	SGM2019-1.8YN5G/TR
U404	03-25041-12	Flash	AT25DF041A-SH-T
U404	03-25041-01	Flash	AT25DF041A-SH-T
U405	03-00303-30	voltage detector	NCP303LSN30T1G
U406	03-00303-09	voltage detector	NCP303LSN09T1G
U407	03-00707-02	Buffer	NC7WZ07P6X
U408	03-02012-01	Regulator	FAN2012MPX
U409	03-00704-03	Inverter	NC7SZU04M5X
U499	03-00221-02	High-Speed USB 2.0 (480 Mbps) 1:2 Multiplexer/Demultiplexer Switch With Single Enable	TS3USB221ARSER
U204, U604, U606, U609	03-07157-02	2:1 multiplexer	NC7SV157P6X
U203	03-07474-02	TRIGGERED DUAL-D FLIP-FLOP	SN74HC74PWR
U104	03-03306-01	2-bit Bus Switch	PI5C3306LE
U608	03-00431-05	Shunt Regulator	TL431CDBZR
U607	03-00393-03	Dual Differential Comparator	LM393DR
U607	or 03-00393-01	Dual Differential Comparator	LM393DR2G
U626	03-01117-09	Regulator	ZLDO1117GTA
	<b>RESISTORS</b>		
R118, R120, R401, R403, R409, R414, R421, R422, R423, R429, R443, R444, R445, R446	07-90000-00	Chip Resistor	0Ω, 0603, ±5%
R217, R220, R434	07-90479-00	Chip Resistor	4.7Ω, 0603, 1/10W, ±5%, RC0603JR-074R7L
R130	07-90100-00	Chip Resistor	10Ω, 0603, 1/10W, ±5%, RC0603JR-0710RL
R213, R214, R215, R216, R218, R219, R221, R402, R406, R407, R410, R416, R419, R424, R427, R430, R431, R433, R438, R439, R441, R450	07-90330-00	Chip Resistor	33Ω, 0603, 1/10W, ±5%, RC0603JR-0733RL
R200, R201	07-90750-00	Chip Resistor	75Ω, 0603, 1/10W, ±5%, RC0603JR-0775RL
R104, R105, R109, R111, R117, R126, R131, R132, R133, R134, R141, R142, R144, R146, R148, R149, R152, R159, R211, R212, R222, R223, R225, R412, R447, R448, R449, R703	07-90101-00	Chip Resistor	100Ω, 0603, 1/10W, ±5%, RC0603JR-07100RL
R224, R226, R228, R229	07-90121-00	Chip Resistor	120Ω, 0603, 1/10W, ±5%, RC0603JR-07120RL

R694	07-91500-00	Chip Resistor	150Ω,0603,1/10W,±1%,RC0603FR-07150RL
R698	07-90241-00	Chip Resistor	240Ω,0603,1/10W,±5%,RC0603JR-07240RL
R442	07-94700-00	Chip Resistor	470Ω,0603,1/10W,±1%,RC0603FR-07470RL
R137, R150, R151, R153, R155, R156, R203, R417, R418, R425, R426	07-91001-00	Chip Resistor	1KΩ,0603,1/10W,±1%,RC0603FR-071K1L
R436	07-91801-00	Chip resistor	1.8KΩ,0603,1/10W,±1%,RC0603FR-071K8L
R143, R154, R704	07-94701-00	Chip Resistor	4.7KΩ,0603,1/10W,±1%,RC0603FR-074K7L
R437	07-96801-00	Chip Resistor	6.8KΩ,0603,1/10W,±1%,RC0603FR-076K8L
R408	07-98061-00	Chip Resistor	8.06KΩ,0603,1/10W,±1%,RC0603FR-078K06L
R107, R108, R123, R127, R138, R145, R147, R158, R205, R207, R208, R209, R210, R405, R415, R420, R428, R432, R435, R695, R696, R697	07-90103-00	Chip Resistor	10KΩ,0603,1/10W,±5%,RC0603JR-0710K1L
R202	07-91002-00	Chip Resistor	10KΩ,0603,1/10W,±1%,RC0603FR-0710K1L
R400	07-92002-00	Chip Resistor	20KΩ,0603,1/10W,±1%,RC0603FR-0720K1L
R112, R204, R206, R411, R700	07-90473-00	Chip Resistor	47KΩ,0603,1/10W,±5%,RC0603JR-0747K1L
R103, R106, R110	07-90104-00	Chip Resistor	100KΩ,0603,1/10W,±5%,RC0603JR-07100K1L
R699	07-91213-00	Chip Resistor	121KΩ,0603,1/10W,±1%,RC0603FR-07121K1L
R701	07-91623-00	Chip Resistor	162KΩ,0603,1/10W,±1%,RC0603FR-07162K1L
R440	07-92204-00	Chip resistor	2.2MΩ,0603,1/10W,±1%,RC0603FR-072M2L
R100, R101, R102, R404	07-90101-01	Chip Resistor	100Ω,0805,1/8W,±5%,RC0805JR-07100RL
R113, R115	07-90103-01	Chip Resistor	10KΩ,0805,1/8W,±5%,RC0805JR-0710K1L
R116	07-92802-01	Chip Resistor	28KΩ,0805,1/8W,±1%,RC0805FR-0728K1L
R114	07-90563-01	Chip Resistor	56KΩ,0805,1/8W,±5%,RC0805JR-0756K1L
R682, R702	07-99532-01	Chip Resistor	95.3KΩ,0805,1/8W,±1%,RC0805FR-0795K3L
R160	07-91000-02	Chip Resistor	100Ω,1206,1/4W,±1%,RC1206FR-07100RL
R119, R121, R122, R124, R125, R128, R129	07-90101-10	Chip Resistor NET	100Ω, ±5% R0603X4
<b>CAPACITORS</b>			
C456, C457	26-33051-00	Ceramic Chip Capacitor	33P,0603,50V,NPO
C132, C133, C134, C135, C213, C215, C217, C218, C229, C406	26-10151-00	Ceramic Chip Capacitor	100pJ,50V,0603,NPO,C1608C0G1H101JT
C742	26-10251-10	Ceramic Chip Capacitor	1nJ,50V,0603,NPO,C1608C0G1H102JT
C104, C106, C108, C111, C112, C117, C119, C120, C121, C122, C123, C124, C127, C131, C140, C156, C219, C225, C227, C230, C231, C233, C400, C402, C410, C412, C414, C415, C418, C419, C420, C421, C422, C423, C426, C428, C429, C430, C431, C432, C433, C439, C440, C441, C442, C443, C444, C445, C446, C447, C448, C450, C451, C452, C453, C454, C455, C458, C622, C626, C653, C740, C741, C744	26-10411-00	Ceramic Chip Capacitor	100nF,16V 0603, X7R
C113, C129, C228, C181	26-10521-10	Ceramic Chip Capacitor	1uF,25V,±10%,0603,X5R
C209	26-10212-01	Ceramic Chip Capacitor	1nJ,100V,0805,NPO
C136, C139, C405, C417	26-10351-01	Ceramic Chip Capacitor	10nK,50V,0805,X7R
C100, C101, C102	26-22312-01	Ceramic Chip Capacitor	22nF,100V 0805, X7R

C200, C202, C204, C210, C211, C212, C214, C216, C220, C222, C201, C203	26-10411-01	Ceramic Chip Capacitor	100nK,16V,0805,X7R
C208	26-47411-01	Ceramic Chip Capacitor	470nK,16V,0805,X7R
C427, C449, C103, C105, C459, C207, C411, C413	26-22521-01	Ceramic Chip Capacitor	2.2uF,±10%,25V,X5R,0805
C224, C226	26-47511-01	Ceramic Chip Capacitor	4.7uF, 16V, X5R,0805
C137, C138, C407, C435, C436, C735	26-10611-01	Ceramic Chip Capacitor	10uF,0805,10V,C0805C106M8PACTU/C2012X5R1A106M
C110, C126, C206, C221, C223, C401, C425, C437, C438, C736, C738, C743	26-22660-11	Ceramic Chip Capacitor	22uF, 6.3V, X5R, 0805
C118, C125	26-10351-00	Ceramic Chip Capacitor	10nK,50V,0603,X7R,C2012X7R1H103KT
C107, C109, C130	26-22411-10	Ceramic Chip Capacitor	220nF, 16V, X7R, 0603
C734	06-10211-12	Alu Electrolytic Capacitor	1000uF,10V,±20%,105℃,EEUFC1A102(B)
C205, C424, C729	06-33160-11	Alu Electrolytic Capacitor	ULR337MOJE06RR,330uF,6.3V,±20%,105℃,F2.5
C128	06-47160-00	Alu Electrolytic Capacitor	CD289,470uF,6.3V,±20%,Pitch=2.5mm D=6.3mm
<b>INDUCTANCE</b>			
FB100, FB101, FB103, FB104, FB105	08-04601-10	Ferrite Bead SMD	CBA321609-4U-601
L401	08-05100-01	Inductor	LQH32CN100K33L,10uH,1210
L100	08-04102-11	Chip Bead	74279205 1000ohm@100MHz
L400, L403, L408, L409, L101, L102,L602	08-04102-31	Chip Ferrite Bead	742792662, 1000ohm@100MHz,Imax=600mA
L404, L405, L407, L200, L202, L203, L105, L410	08-04331-06	Ferrite Bead SMD	742792037, 330ohm@100MHz, ±25%, 2A
L406	08-04100-24	Inductor SMD	74477410,10uH
T200, T201	22-22133-00	Transformer	PE-65612NL
L402	08-01479-00	Power Inductor	JP0909-4R7M,4.7uH
L104	08-05550-00	Resonance Inductor	T9*5*3-55uH
<b>CRYSTAL</b>			
Y400	04-11302-01	Crystal SMD	HC-49/SMD,13MHz,CL=20pF,FL=20PPM
<b>CONNECTORS</b>			
SW100	11-04101-13	Tact Switch	IT-1102VLD-1160
J400	J17-08001-58	USB connector	292304-1
(J200, J201)	17-01002-31	RCA JACK	RCA-214EA
P600	17-07101-03	DC Phone Jack	DC-005
J100	13-22014-05	Connector Socket	2.0mm,2x7Pin,CNT-B200-2*7-GD-3/8.6-N
J498	13-22034-01	Connector Socket	2.0mm, 2x17Pin,CNT-B200-2*17-GD-3/8.6-N
CON100	13-22010-02	Connector Socket	2.0mm,1*10Pin,90°,PH-S10A
P100	13-12504-39	Connector	2.54mm, 2x2Pin,CNT-M254-2*2-GD-6/3/2-N
OP201, OP202	17-06001-07	Optical Receive	DLR2180/25M
CON101	13-12505-19	Connector Socket	2.54mm,5Pin, CNT-M254-1*5-GS-4/3-1.5-N
	70-351001-1	Heatsink	AL1050
	61-023508-0	Machine Screw	MB3x8
	78-351001-0	Insulated Pad	46x11x2.5mm
	14-40504-00	Connector Wire	L=190mm
	14-40534-00	Connector Wire	IDC PH2.0-34P,L=75mm
	14-40514-10	Connector Wire	IDC PH2.0-14P,L=200mm
	14-40510-00	Connector Wire	L=120mm
	19-15022-00	Ferrite Ring	740417
	79-351002-0	PORON bar	PORON,73x3x0.5mm
	79-351004-0	LED foam	EVA,68x32x5mm
	86-108020-0	IR Receiver Foam	EVA,Black, 6.5x7.5x2.5
	90-359002-0		PET T=0.07
	66-351003-1	U type bracket	SECC T=0.8
	61-023106-0	Self Tapping Screw	STB 3x6
	61-063512-0	Machine Screw	MF3x12
	61-023506-0	Machine Screw	MB3x6
	85-320001-0	Nylon Spacer	3-5mm
	66-351001-0	bar bracket	SECC-N5, T=1.5mm
	70-351002-2	inner plate	AL 1015
	70-351004-0	Heatsink B	AL 1050

	61-063506-0	Machine Screw	MF3x6
	61-062506-5	Machine Screw	MF2.5X6mm
	61-063208-0	Self Tapping Screw	BTF3x8
<b>PCB-5:FPP BOARD</b>			
<b>CIRCUIT NO.</b>	<b>PART NO.</b>		<b>DESCRIPTION</b>
	<b>PCB INFO</b>		
	A16-40503-22	FPP PCB	VM2.0,FR-4,TG130,95.7X39.7mm
	A16-40530-22	FPP PCB	VM2.0,FR-4,1.0mm,,213x124.2mm
	<b>DIODES</b>		
D1, D2, D3, D4, D5, D900, D901, D902, D903, D904, D905, D906, D907, D908, D909, D910	N33-50603-91	LED	WR-PB1608UW-M58
	<b>TRANSISTORS</b>		
Q900, Q901, Q902	31-03326-01	Transistor	2SC3326-A(TE85L,F), SC-59
	<b>ICS</b>		
U902, U903, U906	03-00717-01	TinyLogic UHS Dual Buffer with Schmitt Trigger	NC7WZ17
U904, U905	03-00595-01	Shift Register	SN74HC595D/74HC595D/MM74HC595M
U901	03-34838-00	IR Receiver	TSOP34838
	<b>RESISTORS</b>		
R903	07-91000-00	Chip Resistor	100Ω,0603,1/10W,±1%,RC0603FR-07100RL
R1, R2, R3, R4, R5, R908, R909, R910, R911, R912, R913, R915, R916, R917, R918, R919	07-92400-00	Chip Resistor	240Ω,0603,1/10W,±1%,RC0603FR-07240RL
R920, R921, R922	07-92201-00	Chip Resistor	2.2KΩ,0603,1/10W,±1%,RC0603FR-072K2L
R907	07-90101-10	Chip Resistor NET	100Ω, ±5% R0603X4
R914	07-91002-00	Chip Resistor	10KΩ,0603,1/10W,±1%,RC0603FR-0710KL
R904	07-91009-01	Chip Resistor	10Ω,0805,1/10W,±1%,RC0805FR-0710RL
	<b>CAPACITORS</b>		
C913, C914, C915, C924	26-10151-00	Ceramic Chip Capacitor	100pF,50V,0603,NPO
C922, C923	26-47151-00	Ceramic Chip Capacitor	470pJ,50V,0603,NPO
C921	26-10251-10	Ceramic Chip Capacitor	1nJ,50V,0603,NPO,C1608C0G1H102JT
C901	26-47411-00	Ceramic Chip Capacitor	470nZ,16V,0603,Y5V
C907	26-22521-01	Ceramic Chip Capacitor	2.2uF,±10%,25V,X5R,0805
C902	26-10611-01	Ceramic Chip Capacitor	10uF,0805,10V,C0805C106M8PACTU/C2012X5R1A106M
C903, C908, C909, C911, C912	26-10411-00	Ceramic Chip Capacitor	100nF,16V,0603, X7R
	<b>INDUCTANCE</b>		
L901	08-04102-31	Chip Ferrite Bead	742792662, 1000ohm@100MHz,Imax=600mA
L900	08-04102-11	Chip Bead	74279205 1000ohm@100MHz
	<b>CONNECTORS</b>		
J900	13-22014-04	Connector Socket	2.0mm, 2x7Pin,CNT-B200-2*7-GM-7.5-TR
	75-351001-0	LED bracket	ABS765B
	76-351002-0A	film	PET
<b>PCB-6:ENCODE BOARD</b>			
<b>CIRCUIT NO.</b>	<b>PART NO.</b>		<b>DESCRIPTION</b>
	<b>PCB INFO</b>		
	A16-40509-21	ENCODER PCB	VM1.0,FR-4,1.0mm,20.5x38mm
	A16-40530-22	FPP PCB	VM2.0FR-4,1.0mm,213x124.2mm
	<b>RESISTORS</b>		
R905, R906	07-91002-01	Chip Resistor	10KΩ,0805,1/8W,±1%,RC0805FR-0710KL
	<b>CAPACITORS</b>		
C904	26-10611-01	Ceramic Chip Capacitor	10uF,0805,10V,C0805C106M8PACTU/C2012X5R1A106M
C905, C906	26-10411-01	Ceramic Chip Capacitor	100nK,16V,0805,X7R
	<b>CONNECTORS</b>		
J909	13-21006-05	FFC Connector	1.0-9-6PB/ F10009Y-6-A013
S900	28-24308-03	ENCODER	EC12E2430803

<b>PCB-7:Touch B BOARD</b>			
<b>CIRCUIT NO.</b>	<b>PART NO.</b>		<b>DESCRIPTION</b>
	<b>PCB INFO</b>		
	A16-40504-21	Touch PCB	VM1.0,FR-4,1.0mm,80x30mm
	A16-40530-22	FPP PCB	VM2.0,FR-4,1.0mm,213x124.2mm
	<b>DIODES</b>		
TD902	33-50603-04	AMBER LED	SML-311YTT86
TD900, TD901	N33-50603-91	LED	WR-PB1608UW-M58
TD903, TD904	33-50603-60	LED (Blue)	L-C191LBCT
	<b>TRANSISTORS</b>		
TQ904, TQ905, TQ906	31-03326-01	Transistor	2SC3326-A(TE85L,F), SC-59
TR903, TR904	07-91000-01	CHIP Resistor	100Ω,0805,1/8W,±1%,RC0805FR-07100RL
TR902	07-91600-01	CHIP Resistor	160Ω,0805,1/8W,±1%,RC0805FR-07160RL
TR900, TR901	07-92200-01	CHIP Resistor	220Ω,0805,1/8W,±1%,RC0805FR-07220RL
TR950, TR951, TR952	07-92201-01	Chip Resistor	2.2KΩ,0805,1/8W,±1%,RC0805FR-072K2L
	<b>CAPACITORS</b>		
TC917, TC919, TC920	26-10151-01	Ceramic Chip Capacitor	100pJ,50V,0805,NPO,C2012C0G1H101JT
TC950	26-10611-01	Ceramic Chip Capacitor	10uF,0805,10V,C0805C106M8PACTU/C2012X5R1A106M
	<b>CONNECTORS</b>		
TJ908	13-21006-05	FFC Connector	1.0-9-6PB/ F10009Y-6-A013
TCON910	13-22010-00	Connector Socket	PH 2.0A-10A
TJ900, TJ901, TJ902, TJ903	13-22006-06	Connector	2.0m, 2x3pin, CNT-F200-2*3-GS-430/2.4
	90-325003-0	diffusible film	MB-533,16x16x0.3mm
	79-351001-1	button EVA	EVA,56x30x7
	90-351001-1	diffusible film A	MB-533,69x29x0.2mm
	86-351001-0	button adhesive	YS247D,70x44.5mm
<b>PCB-8:Touch A BOARD</b>			
<b>CIRCUIT NO.</b>	<b>PART NO.</b>		<b>DESCRIPTION</b>
	<b>PCB INFO</b>		
	A16-40508-21	Touch A PCB	VM1.0,FR-4,1.0mm,80x44.5mm
	A16-40530-22	FPP PCB	VM2.0,FR-4,1.0mm,213x124.2mm
	<b>CONNECTORS</b>		
TJ904, TJ905, TJ906, TJ907	13-12006-05	Connector	2.0mm, 2x3Pin,CNT-M200-2*3-GM-4/6/0-2.0-TR
<b>MISC AND MACHANCIAL PARTS</b>			
	<b>CONNECTORS</b>		
CONNECT TOUCH TJ908 AND ENCODE J909	14-04306-00	6PIN CABLE	1.0mm,6pin,L=50mm,0.1x0.65
	JA38-00248-00	AC adaptor	GPE248-050400-Z,Input:100-240VAC 50/60Hz 0.75A;Output:5V 4A, US SAA BS GS
	<b>PLASTIC PARTS</b>		
	76-351001-0B	front pannel	PC
	77-351001-1	top cover	ABS765B
	77-351002-1	bottom cover	ABS765B
	75-351002-0	round cover	ABS765B
	79-351003-0	Feet	
	90-040002-0	Polybag	60x90mm
	79-351005-0	Black rubber suport	25*10*4.5
	78-325008-0	insulpad F	GK-17,30x5x0.4mm
	78-359004-0	insulpad D	GK-17,45x55x0.4mm
	<b>METAL PARTS</b>		
	67-351002-0C	rear plate	SECC-N5,T=0.6mm
	80-351002-0	rear plate	SECC-N5,T=0.6mm
	65-351002-0	rear plate	SECC-N5, T=0.6mm
	66-351002-0	vent plate	SUS 304
	70-351003-1	Badge	AL,17x17mm
	J71-325002-0	knob_sec assy	

<b>FASTENERS</b>			
	61-022206-6	Self Tapping Screw	BTB2.6x6
	61-062506-5	Machine Screw	MF2.5X6mm
	61-063208-0	Self Tapping Screw	BTF3x8
	61-023208-0	Self Tapping Screw	BTB3x8
<b>PACKING</b>			
	88-351001-0B	gift box	
	88-351002-1A	shipping box	445x278x357mm
	88-351003-2	egg_A	
	90-351003-1		360x260
	88-351005-0A	sleeve box	
	88-351006-0A	accessory box	
	88-351007-0	clap board A	296x250mm
	88-351008-1	clap board B	442x276mm
	90-351004-1	shrink film	PET,500x400mm
	30-44050-01	Quick start Guide	157g, 420X297mm
	90-325002-0	Non-woven Cloth	40mmx20mm
	94-351001-0	S/N Label	47x9mm
	86-004709-0	Copperplate Label	47x9mm
	94-351002-0	S/N Label	53x10mm
	86-000053-0	Copperplate Label	53x10mm
	94-351003-0	shipping box version Label	115x85mm,R=1mm
	30-51500-01	Guarantee Card(2013)	
	94-000006-0	Sealed Label	PC, Φ65mm

# SERVICE MANUAL

**D1050**

**USB DAC**