

SERVICE MANUAL



L 70

AV SURROUND
SOUND DVD RECEIVER

L 70

AV SURROUND
SOUND DVD RECEIVER

Identification of controls

FRONT PANEL

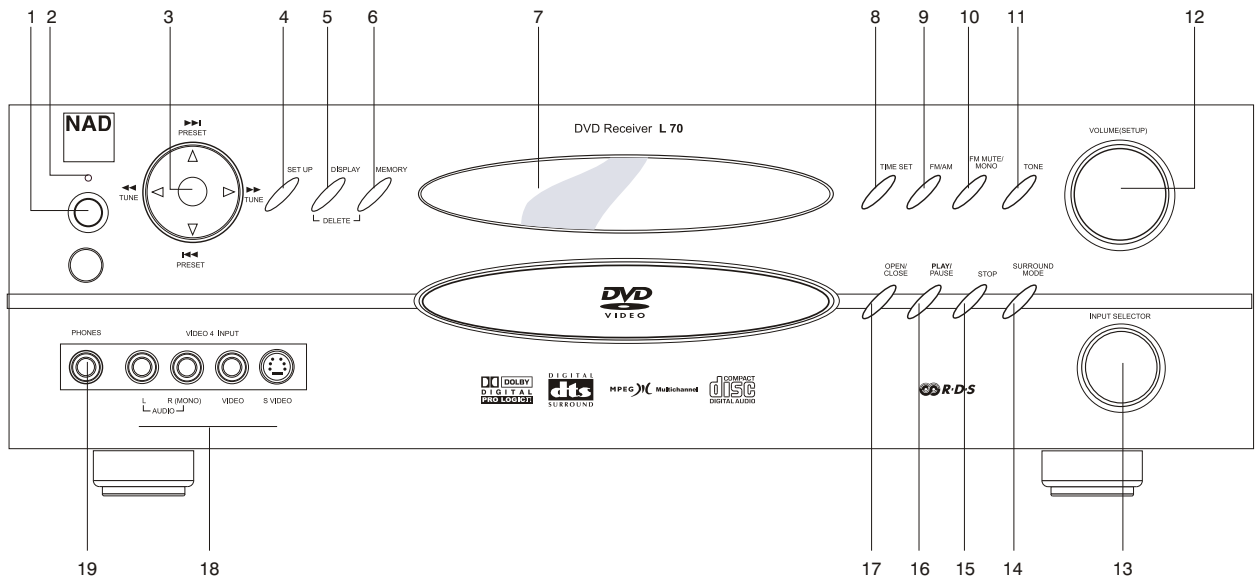

Identification of controls

REAR PANEL

ATTENTION!

Please make all connections to your L70 receiver with the unit unplugged. (It is also advisable to power-down or unplug all associated components while making or breaking any signal or AC power connections.)

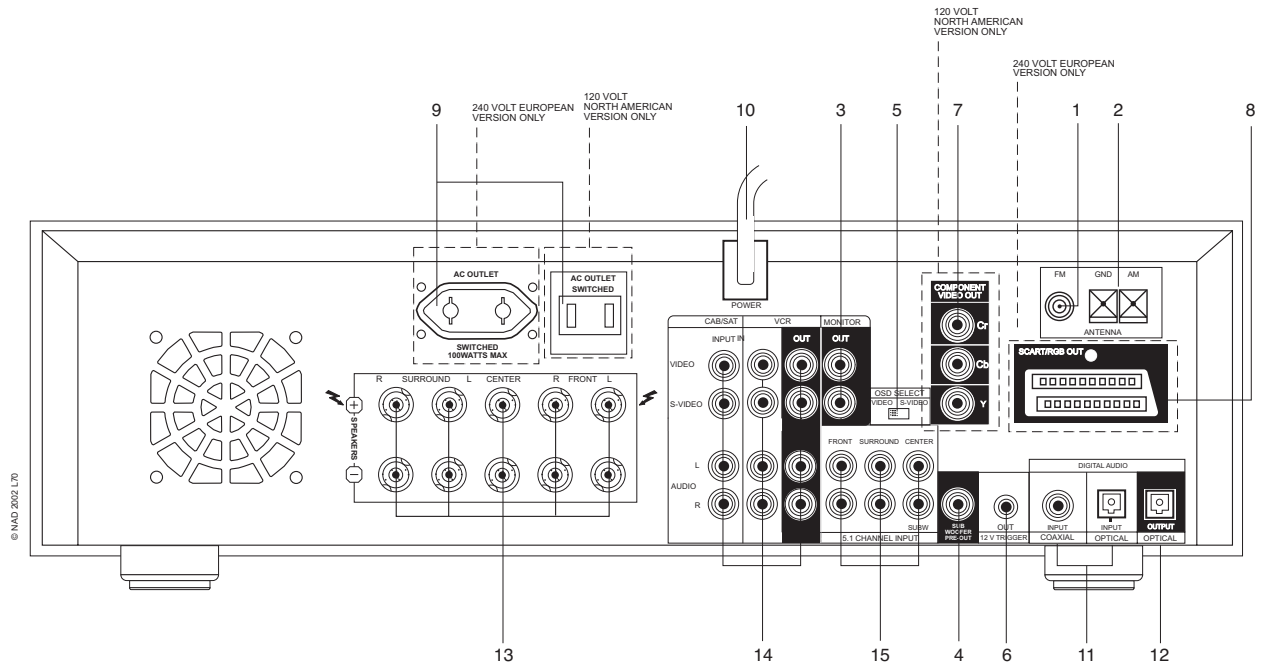

SECTION 1

SUMMARY

CONTENTS

PRODUCT SAFETY SERVICING GUIDELINES.....	1-4
SERVICING PRECAUTIONS	1-5
* General Servicing Precautions	
* Insulation checking procedure	
* Electrostatically Sensitive Devices	
SPECIFICATIONS	1-6
DISASSEMBLY	1-7
PRINCIPAL PART LOCATION	1-8
RESET PROCEDURES	1-8
EXPLODED VIEW	1-9 ~ 1-10

PRODUCT SAFETY SERVICING GUIDELINES

CAUTION : DO NOT ATTEMPT TO MODIFY THIS PRODUCT IN ANY WAY. NEVER PERFORM CUSTOMIZED INSTALLATIONS WITHOUT MANUFACTURER'S APPROVAL. UNAUTHORIZED MODIFICATIONS WILL NOT ONLY VOID THE WARRANTY, BUT MAY LEAD TO YOUR BEING LIABLE FOR ANY RESULTING PROPERTY DAMAGE OR USER INJURY.

SERVICE WORK SHOULD BE PERFORMED ONLY AFTER YOU ARE THOROUGHLY FAMILIAR WITH ALL OF THE FOLLOWING SAFETY CHECKS AND SERVICING GUIDELINES. TO DO OTHERWISE, INCREASES THE RISK OF POTENTIAL HAZARDS AND INJURY TO THE USER.

WHILE SERVICING, USE AN ISOLATION TRANSFORMER FOR PROTECTION FROM AC LINE SHOCK.

SAFETY CHECKS

AFTER THE ORIGINAL SERVICE PROBLEM HAS BEEN CORRECTED. A CHECK SHOULD BE MADE OF THE FOLLOWING.

SUBJECT : FIRE & SHOCK HAZARD

1. BE SURE THAT ALL COMPONENTS ARE POSITIONED IN SUCH A WAY AS TO AVOID POSSIBILITY OF ADJACENT COMPONENT SHORTS. THIS IS ESPECIALLY IMPORTANT ON THOSE MODULES WHICH ARE TRANSPORTED TO AND FROM THE REPAIR SHOP.
2. NEVER RELEASE A REPAIR UNLESS ALL PROTECTIVE DEVICES SUCH AS INSULATORS, BARRIERS, COVERS, SHIELDS, STRAIN RELIEFS, POWER SUPPLY CORDS, AND OTHER HARDWARE HAVE BEEN REINSTALLED PER ORIGINAL DESIGN. BE SURE THAT THE SAFETY PURPOSE OF THE POLARIZED LINE PLUG HAS NOT BEEN DEFEATED.
3. SOLDERING MUST BE INSPECTED TO DISCOVER POSSIBLE COLD SOLDER JOINTS, SOLDER SPLASHES OR SHARP SOLDER POINTS. BE CERTAIN TO REMOVE ALL LOOSE FOREIGN PARTICLES.
4. CHECK FOR PHYSICAL EVIDENCE OF DAMAGE OR DETERIORATION TO PARTS AND COMPONENTS. FOR FRAYED LEADS, DAMAGED INSULATION (INCLUDING AC CORD). AND REPLACE IF NECESSARY FOLLOW ORIGINAL LAYOUT, LEAD LENGTH AND DRESS.
5. NO LEAD OR COMPONENT SHOULD TOUCH A RECEIVING TUBE OR A RESISTOR RATED AT 1 WATT OR MORE. LEAD TENSION AROUND PROTRUDING METAL SURFACES MUST BE AVOIDED.
6. ALL CRITICAL COMPONENTS SUCH AS FUSES, FLAMEPROOF RESISTORS, CAPACITORS, ETC. MUST BE REPLACED WITH EXACT FACTORY TYPES, DO NOT USE REPLACEMENT COMPONENTS OTHER THAN THOSE SPECIFIED OR MAKE UNRECOMMENDED CIRCUIT MODIFICATIONS.
7. AFTER RE-ASSEMBLY OF THE SET ALWAYS PERFORM AN AC LEAKAGE TEST ON ALL EXPOSED METALLIC PARTS OF THE CABINET, (THE CHANNEL SELECTOR KNOB, ANTENNA TERMINALS. HANDLE AND SCREWS) TO BE SURE THE SET IS SAFET TO OPERATE WITHOUT DANGER OF ELECTRICAL SHOCK. DO NOT USE A LINE ISOLATION TRANSFORMER DURING THIS TEST USE AN AC VOLTMETER, HAVING 5000 OHMS PER VOLT OR MORE SENSITIVITY, IN THE FOLLOWING MANNER; CONNECT A 1500 OHM 10 WATT RESISTOR, PARALLELED BY A .15 MFD, 150V AC TYPE CAPACITOR BETWEEN A KNOWN GOOD EARTH GROUND (WATER PIPE, CONDUIT, ETC.) AND THE EXPOSED METALLIC PARTS, ONE AT A TIME.
MEASURE THE AC VOLTAGE ACROSS THE COMBINATION OF 1500 OHM RESISTOR AND .15 MFD CAPACITOR.
REVERSE THE AC PLUG AND REPEAT AC VOLTAGE MEASUREMENTS FOR EACH EXPOSED METALLIC PART.

VOLTAGE MEASURE MUST NOT EXCEED 75 VOLTS R.M.S. THIS CORRESPONDS TO 0.5 MILLIAMPER AC ANY VALUE EXCEEDING THIS LIMIT CONSTITUTES A POTENTIAL SHOCK HAZARD AND MUST BE CORRECTED IMMEDIATELY.

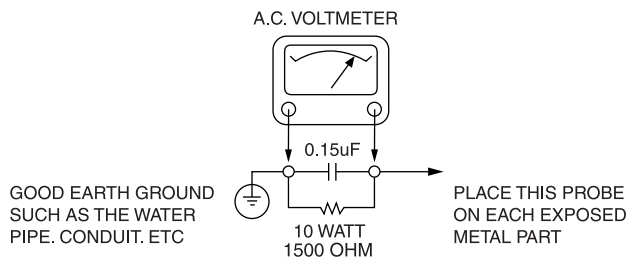

SUBJECT : GRAPHIC SYMBOLS



THE LIGHTNING FLASH WITH ARROWHEAD SYMBOL, WITHIN AN EQUILATERAL TRIANGLE, IS INTENDED TO ALERT THE USER TO THE PRESENCE OF UNINSULATED "DANGEROUS VOLTAGE" WITHIN THE PRODUCT'S ENCLOSURE THAT MAY BE OF SUFFICIENT MAGNITUDE TO CONSTITUTE A RISK OF ELECTRIC SHOCK.



THE EXCLAMATION POINT WITHIN AN EQUILATERAL TRIANGLE IS INTENDED TO ALERT THE USER TO THE PRESENCE OF IMPORTANT OPERATING AND MAINTENANCE (SERVICING) INSTRUCTIONS IN THE LITERATURE ACCOMPANYING THE APPLIANCE.

SUBJECT : TIPS ON PROPER INSTALLATION

1. NEVER INSTALL ANY PRODUCT IN A CLOSED-IN RECESS, CUBBYHOLE OR CLOSELY FITTING SHELF SPACE. OVER OR CLOSE TO HEAT DUCT, OR IN THE PATH OF HEATED AIR FLOW.
2. AVOID CONDITIONS OF HIGH HUMIDITY SUCH AS: OUTDOOR PATIO INSTALLATIONS WHERE DEW IS A FACTOR, NEAR STEAM RADIATORS WHERE STEAM LEAKAGE IS A FACTOR, ETC.
3. AVOID PLACEMENT WHERE DRAPERIES MAY OBSTRUCT REAR VENTING. THE CUSTOMER SHOULD ALSO AVOID THE USE OF DECORATIVE SCARVES OR OTHER COVERINGS WHICH MIGHT OBSTRUCT VENTILATION.
4. WALL AND SHELF MOUNTED INSTALLATIONS USING A COMMERCIAL MOUNTING KIT MUST FOLLOW THE FACTORY APPROVED MOUNTING INSTRUCTIONS A PRODUCT MOUNTED TO A SHELF OR PLATFORM MUST RETAIN ITS ORIGINAL FEET (OR THE EQUIVALENT THICKNESS IN SPACERS) TO PROVIDE ADEQUATE AIR FLOW ACROSS THE BOTTOM, BOLTS OR SCREWS USED FOR FASTENERS MUST NOT TOUCH ANY PARTS OR WIRING. PERFORM LEAKAGE TEST ON CUSTOMIZED INSTALLATIONS.
5. CAUTION CUSTOMERS AGAINST THE MOUNTING OF A PRODUCT ON SLOPING SHELF OR A TILTED POSITION, UNLESS THE PRODUCT IS PROPERLY SECURED.
6. A PRODUCT ON A ROLL-ABOUT CART SHOULD BE STABLE ON ITS MOUNTING TO THE CART. CAUTION THE CUSTOMER ON THE HAZARDS OF TRYING TO ROLL A CART WITH SMALL CASTERS ACROSS THRESHOLDS OR DEEP PILE CARPETS.
7. CAUTION CUSTOMERS AGAINST THE USE OF A CART OR STAND WHICH HAS NOT BEEN LISTED BY UNDERWRITERS LABORATORIES, INC. FOR USE WITH THEIR SPECIFIC MODEL OF TELEVISION RECEIVER OR GENERICALLY APPROVED FOR USE WITH T.V.'S OF THE SAME OR LARGER SCREEN SIZE.
8. CAUTION CUSTOMERS AGAINST THE USE OF EXTENSION CORDS, EXPLAIN THAT A FOREST OF EXTENSIONS SPROUTING FROM A SINGLE OUTLET CAN LEAD TO DISASTROUS CONSEQUENCES TO HOME AND FAMILY.

SERVICING PRECAUTIONS

CAUTION : Before servicing the A/V Receiver covered by this service data and its supplements and addends, read and follow the **SAFETY PRECAUTIONS**. **NOTE** : if unforeseen circumstances create conflict between the following servicing precautions and any of the safety precautions in this publication, always follow the safety precautions.

Remember Safety First:

General Servicing Precautions

1. Always unplug the A/V Receiver AC power cord from the AC power source before:
 - (1) Removing or reinstalling any component, circuit board, module, or any other assembly.
 - (2) Disconnecting or reconnecting any internal electrical plug or other electrical connection.
 - (3) Connecting a test substitute in parallel with an electrolytic capacitor.**Caution** : A wrong part substitution or incorrect polarity installation of electrolytic capacitors may result in an explosion hazard.
2. Do not spray chemicals on or near this A/V Receiver or any of its assemblies.
3. Unless specified otherwise in this service data, clean electrical contacts by applying an appropriate contact cleaning solution to the contacts with a pipe cleaner, cottontipped swab, or comparable soft applicator.
Unless specified otherwise in this service data, lubrication of contacts is not required.
4. Do not defeat any plug/socket B+ voltage interlocks with which instruments covered by this service manual might be equipped.
5. Do not apply AC power to this A/V Receiver and/or any of its electrical assemblies unless all solid-state device heat sinks are correctly installed.
6. Always connect test instrument ground lead to the appropriate ground before connecting the test instrument positive lead. Always remove the test instrument ground lead last.

Insulation Checking Procedure

Disconnect the attachment plug from the AC outlet and turn the power on. Connect an insulation resistance meter(500V) to the blades of the attachment plug. The insulation resistance between each blade of the attachment plug and accessible conductive parts (Note 1) should be more than 1M-ohm.

Note 1 : Accessible Conductive Parts including Metal panels, Input terminals, Earphone jacks, etc.

Electrostatically Sensitive (ES) Devices

Some semiconductor (solid state) devices can be damaged easily by static electricity. Such components commonly are called Electrostatically Sensitive (ES) Devices. Examples of typical Es devices are integrated circuits and some field effect transistors and semiconductor chip components.

The following techniques should be used to help reduce the incidence of component damage caused by static electricity.

1. Immediately before handling any semiconductor component or semiconductor-equipped assembly, drain off any electrostatic charge on your body by touching a known earth ground. Alternatively, obtain and wear a commercially available discharging wrist strap device, which should be removed for potential shock reasons prior to applying power to the unit under test.
2. After removing an electrical assembly equipped with ES devices, place the assembly on a conductive surface such as aluminum foil, to prevent electrostatic charge buildup or exposure of the assembly.
3. Use only a grounded-tip soldering iron to solder or unsolder ES devices.
4. Use only an antistatic solder removal device. Some solder removal devices not classified a "anti-static" can generate electrical charges sufficient to damage ES devices.
5. Do not use freonpropelled chemicals. These can generate electrical charge sufficient to damage ES devices.
6. Do not remove a replacement ES device from its protective package until immediately before you are ready to install it. (Most replacement ES devices are packaged with leads electrically shorted together by conductive foam, aluminum foil, or comparable conductive material).
7. Immediately before removing the protective material from the leads of a replacement ES device, touch the protective material to the chassis or circuit assembly into which the device will be installed.

Caution : Be sure no power is applied to the chassis or circuit, and observe all other safety precautions.

8. Minimize bodily motions when handing unpackaged replacement ES devices. (Normally harmless motion such as the brushing together of your clothes fabric or the lifting of your foot from a carpeted floor can generate static electricity sufficient to damage an ES device.)
9. Resetting the L70 is by pressing three front panel keys; PLAY, then STOP, then separately hold the AM/FM key for more than 5 sec. The L70 will switch off.

SPECIFICATIONS

Amplifier Section

Output Power (Front) :

F.T.C Rating:

60 watts RMS per channel minimum, both channels driven into 8 ohms from 20 Hz to 20kHz with no more than 0.09% total harmonic distortion

Surround Output Power (0.5% THD, 1 kHz, 8 ohms) :

50 + 50 Watt (Front)

50 Watt (Center)

50 + 50 Watt (Rear)

Total Harmonic Distortion (Front) :

0.05 % (at 30 watts, 1 kHz)

Delay Time :

DOLBY DIGITAL : REAR : 0 - 15 ms

CENTER : 0 - 5 ms

DOLBY PRO LOGIC : REAR : 15 - 30 ms

Audio Input Sensitivity/Impedance :

*LINE : 320 mV/47 k ohms

Output Level / Impedance :

VCR REC : 300 mV/2.2 k ohms

Frequency Response :

*LINE : 10 Hz - 60 kHz, +1/ -3 dB

Signal-to-Noise Ratio : 1 Watt

*LINE : 70 dB (IHF-A)

Tone Control :

BASS : ± 10 dB at 100 Hz

TREBLE : ± 10 dB at 10 kHz

Digital Audio Section

Sampling Frequency :

32 kHz, 44.1 kHz, 48 kHz, 96 kHz

DIGITAL Input Level/Impedance

COAXIAL : 0.5 Vp-p/75 ohms

OPTICAL : -15 dBm ~ -21 dBm

Video Section

Input Sensitivity /Impedance : 1.0 Vp-p/75 ohms

Output Level /Impedance : 1.0 Vp-p/75 ohms

*LINE means CABLE/SAT, VCR, VIDEO4

- Improvements may result in specifications and features changing without notice.
- Illustrations may differ slightly from production models.

FM Tuner Section

(Without notes 100.1 MHz, 65 dBf)

Tuning Range :

87.5 MHz - 108.0 MHz C: 50 kHz steps

AH: 100 kHz steps

AM Suppression Ratio: C: 50 dB

AH: 60 dB

Total Harmonic Distortion (1 kHz) :

Mono : 0.4%

Stereo : 0.5%

Frequency Respones : 20 Hz - 15 kHz, +1/ -1. 5 dB

Stereo Separation (1 kHz) : C: 40 dB

AH: 35 dB

Signal-to-Noise Ratio :

Mono : 70 dB

Stereo : 65 dB

AM Tuner Section

Tuning Range:

C : 522 kHz - 1,620 kHz (9 kHz steps)

AH : 520 kHz - 1,710 kHz (10 kHz steps)

Usable Sensitivity : 55 dB/m

Total Harmonic Distortion : 0.1% at 85 dB/m

Signal-to-Noise Ratio : 40 dB at 85 dB/m

General

Power Requirements :

C : 230V AC, 50Hz

AH : 120V AC, 60Hz

Power Consumption : C: 1.3A

AH: 2.5A

AC Outlets : unswitched x 1, Total 100 W max. (1A)

Dimensions (W x H x D) : 435 x 133 x 375

Weight (net) : 16.3 kg

DISASSEMBLY

1> REMOVAL OF TOP COVER

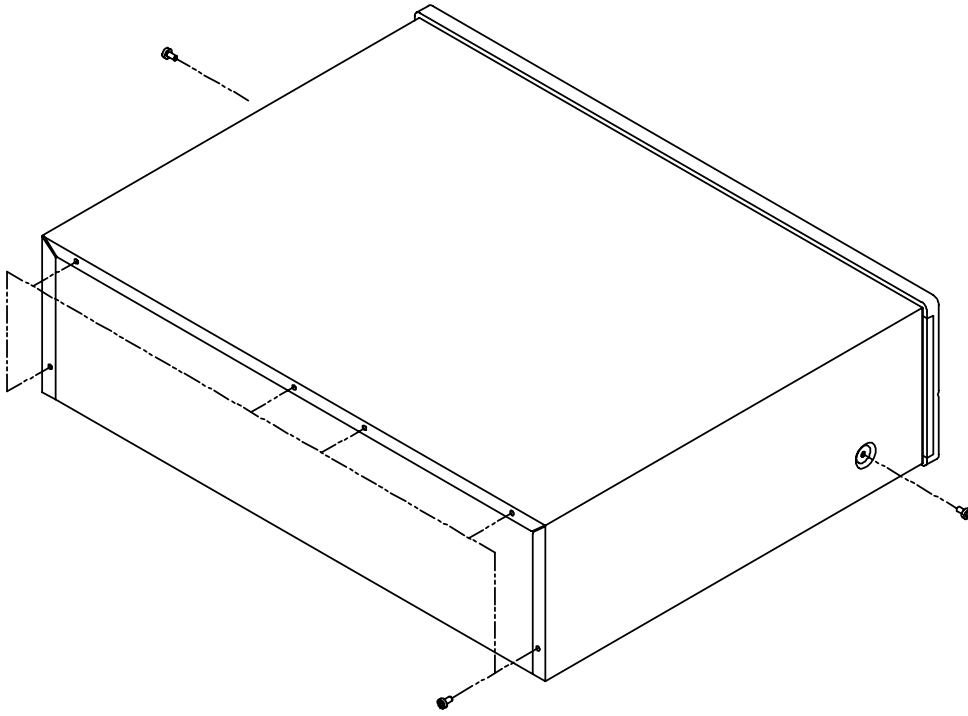

2> REMOVAL OF FRONT PANEL

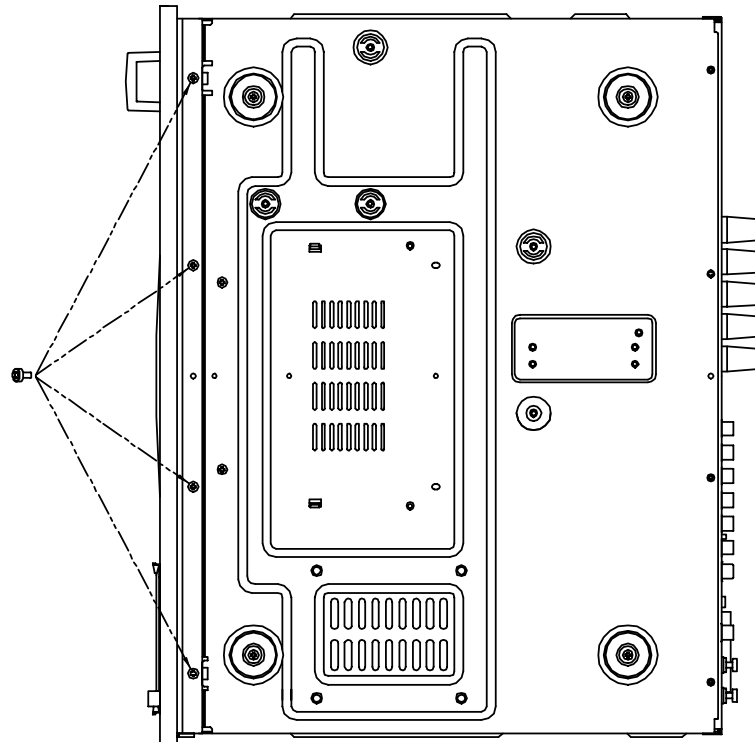
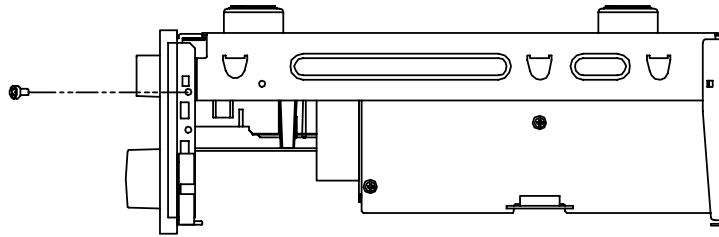

PRINCIPAL PARTS LOCATION L70

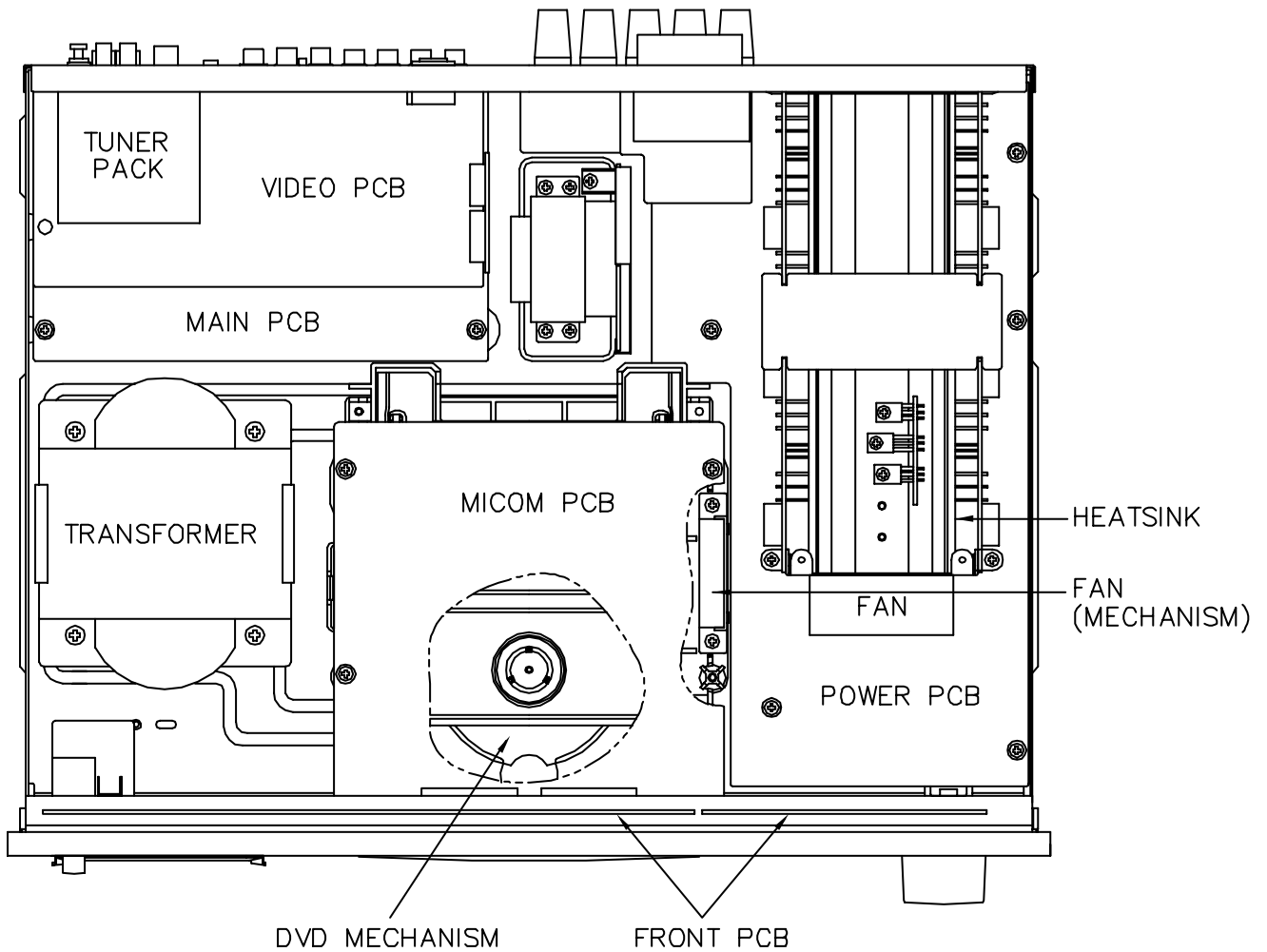

RESET PROCEDURE FOR Receiver Functions Only (place L70 in FM mode):
 Press Play then Stop then the FM/AM key, holding in the FM/AM key for more than 5 seconds.

RESET PROCEDURE FOR DVD-Player Functions Only (DVD OSD mode):
 Select DEFAULTS to restore factory defaults.
 The factory default password is 2580.



EXPLODED VIEW AH & C

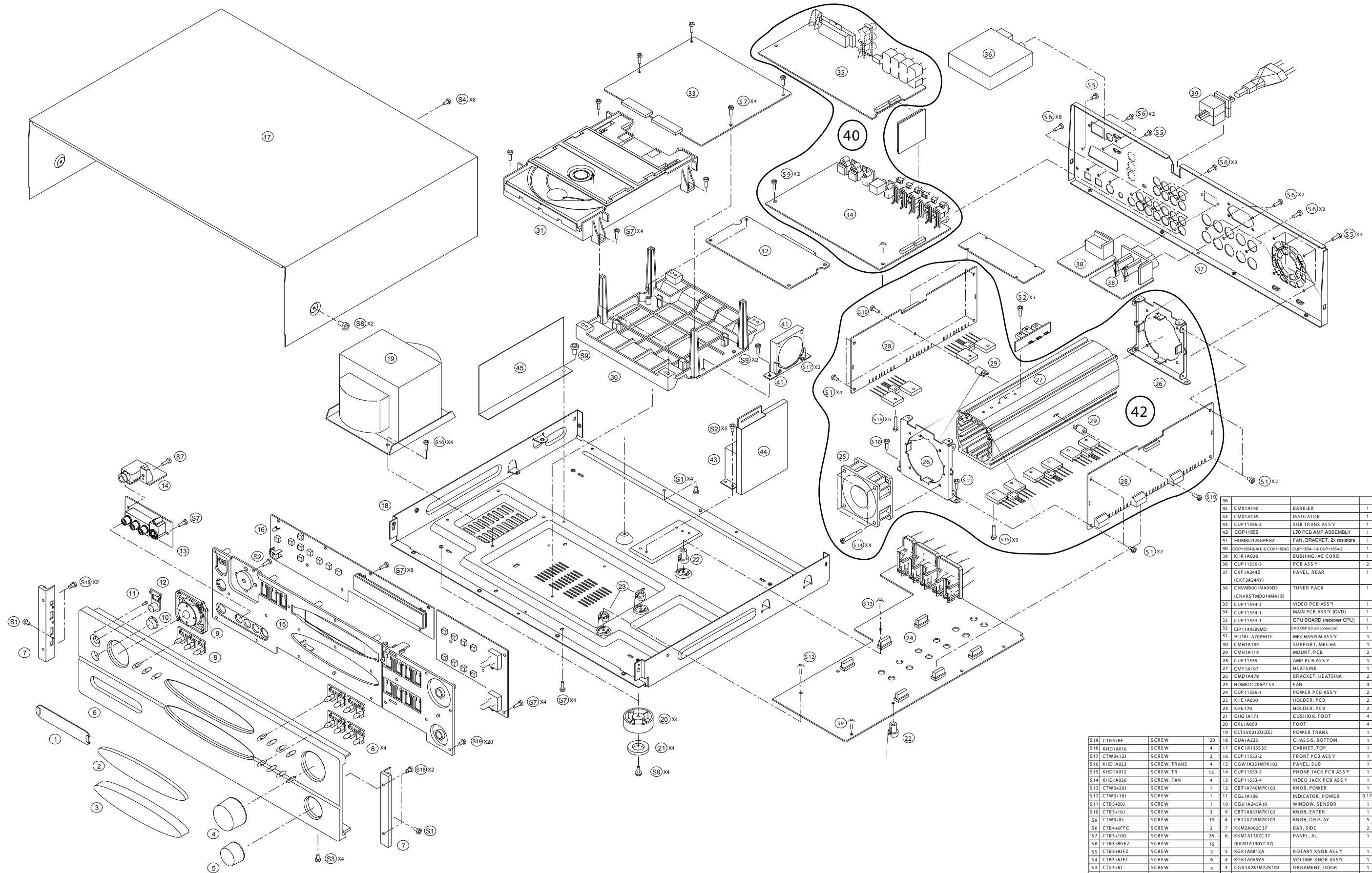

46	CMX1A140	BARRIER	1				
45	CMX1A139	INSULATOR	1				
44	CUP11556-2	SUB TRANS ASS'Y	1				
43	COP11555	L70 PCB AMP ASSEMBLY	1				
42	HDMKD1249PFS2	FAN, BRACKET, 2x resistors	1				
41	COP11554(B/AH) & COP11554C	CUP11554-1 & CUP11554-2	1				
40	KHR1A028	BUSHING, AC CORD	1				
39	CUP11556-3	PCB ASS'Y	2				
38	CKF1A244Z (CKF2A244Y)	PANEL, REAR	1				
37	CNVMB001MA09D5 (CNVKS5TMB014MA18)	TUNER PACK	1				
36	CUP11554-2	VIDEO PCB ASS'Y	1				
35	CUP11554-1	MAIN PCB ASS'Y (DVD)	1				
34	CUP11553-1	CPU BOARD (receiver CPU)	1				
33	DIP11445B5MD	DVD DSP (23 pin connector)	1				
32	HJDL1-A700HD3	MECHANISM ASS'Y	1				
31	CMHTA189	SUPPORT, MECHA	1				
30	CMHTA119	MOUNT, PCB	2				
29	CUP11555	AMP PCB ASS'Y	1				
28	CMY1A197	HEATSINK	1				
27	CMD1A479	BRACKET, HEATSINK	2				
26	HDMKD1206P1S3	FAN	3				
25	CUP11556-1	POWER PCB ASS'Y	2				
24	RHE1A030	HOLDER, PCB	2				
23	RHE170	HOLDER, PCB	2				
22	CHG1A171	CUSHION, FOOT	4				
21	CKL1A060	FOOT	4				
20	CLTVS0312U1ZE1	POWER TRANS	1				
19	CUA1A223	CHASSIS, BOTTOM	1				
18	KHD1A016	CABINET, TOP	1				
17	CTW3+12J	FRONT PCB ASS'Y	1				
16	CGW1A351M7K102	PANEL, SUB	1				
15	CUP11553-2	PHONE JACK PCB ASS'Y	1				
14	CUP11553-5	VIDEO JACK PCB ASS'Y	1				
13	CUP11553-4	VIDEO JACK PCB ASS'Y	1				
12	CBT1A746M7K102	KNOB, POWER	1				
11	CGL1A188	INDICATOR, POWER	0.17				
10	CGU1A245A10	WINDOW, SENSOR	1				
9	CBT1A853M7K102	KNOB, ENTER	1				
8	CBT1A745M7K102	KNOB, DISPLAY	5				
7	KKM2A062C37	BAR, SIDE	2				
6	KKM1A1302C37	PANEL, AL	1				
5	KKM1A130YC37	PANEL, AL	1				
4	KGK1A081ZA	ROTARY KNOB ASS'Y	1				
3	KGK1A063YA	VOLUME KNOB ASS'Y	1				
2	CGR1A287M7K102	ORNAMENT, DOOR	1				
1	CGU1A244A8	WINDOW, FIP	1				
0.17	CGR1A288M7K102	COVER, JACK	1				
NO.	PARTS NO.	DESCRIPTION	QTY	NO.	PARTS NO.	DESCRIPTION	QTY

EXPLODED VIEW AH & C

				46			
				45	CMX1A140	BARRIER	1
				44	CMX1A139	INSULATOR	1
				43	CUP11556-2	SUB TRANS ASS'Y	1
				42	COP11555	L70 PCB AMP ASSEMBLY	1
				41	HDMKD1245PFS2	FAN, BRACKET, 2x resistors	1
				40	COP11554B(AH) & COP11554C	CUP11554-1 & CUP11554-2	1
				39	KHR1A028	BUSHING, AC CORD	1
				38	CUP11556-3	PCB ASS'Y	2
				37	CKF1A244Z (CKF2A244Y)	PANEL, REAR	1
				36	CNVMB001MA09DS (CNVKSTMB014MA18)	TUNER PACK	1
				35	CUP11554-2	VIDEO PCB ASS'Y	1
				34	CUP11554-1	MAIN PCB ASS'Y (DVD)	1
				33	CUP11553-1	CPU BOARD (receiver CPU)	1
				32	CIP11445BSMD	DVD DSP (23 pin connector)	1
				31	HJDRL-A700HD3	MECHANISM ASS'Y	1
				30	CMH1A189	SUPPORT, MECHA	1
				29	CMH1A119	MOUNT, PCB	2
				28	CUP11555	AMP PCB ASS'Y	1
				27	CMY1A197	HEATSINK	1
				26	CMD1A479	BRACKET, HEATSINK	2
				25	HDMKD1206PTS3	FAN	3
				24	CUP11556-1	POWER PCB ASS'Y	2
				23	KHE1A030	HOLDER, PCB	2
				22	KHE170	HOLDER, PCB	2
				21	CHG1A171	CUSHION, FOOT	4
				20	CKL1A060	FOOT	4
				19	CLT5V031ZU(ZE)	POWER TRANS	1
S19	CTB3+6F	SCREW	20	18	CUA1A223	CHASSIS, BOTTOM	1
S18	KHD1A016	SCREW	4	17	CKC1A135S35	CABINET, TOP	1
S17	CTW3+12J	SCREW	2	16	CUP11553-2	FRONT PCB ASS'Y	1
S16	KHD1A023	SCREW, TRANS	4	15	CGW1A351M7K102	PANEL, SUB	1
S15	KHD1A012	SCREW, TR	15	14	CUP11553-5	PHONE JACK PCB ASS'Y	1
S14	KHD1A036	SCREW, FAN	4	13	CUP11553-4	VIDEO JACK PCB ASS'Y	1
S13	CTW3+20J	SCREW	1	12	CBT1A746M7K102	KNOB, POWER	1
S12	CTW3+16J	SCREW	1	11	CGL1A188	INDICATOR, POWER	0.17
S11	CTB3+20J	SCREW	1	10	CGU1A245A10	WINDOW, SENSOR	1
S10	CTB3+16J	SCREW	3	9	CBT1A853M7K102	KNOB, ENTER	1
S9	CTW3+8J	SCREW	13	8	CBT1A745M7K102	KNOB, DISPLAY	5
S8	CTB4+6FFC	SCREW	2	7	KKM2A062C37	BAR, SIDE	2
S7	CTB3+10G	SCREW	26	6	KKM1A130ZC37 (KKM1A130YC37)	PANEL, AL	1
S6	CTB3+8GFZ	SCREW	15	5	KGK1A081ZA	ROTARY KNOB ASS'Y	1
S5	CTB3+8JFZ	SCREW	5	4	KGK1A063YA	VOLUME KNOB ASS'Y	1
S4	CTB3+8JFC	SCREW	6	3	CGR1A287M7ZK102	ORNAMENT, DOOR	1
S3	CTS3+8J	SCREW	4	2	CGU1A244A8	WINDOW, FIP	1
S2	CTB3+8J	SCREW	6	1	CGR1A288M7K102	COVER, JACK	1
S1	CTB3+6J	SCREW	15				
NO.	PARTS NO.	DESCRIPTION	Q'TY	NO.	PARTS NO.	DESCRIPTION	Q'TY

SECTION 2

ELECTRICAL CONTENTS

CONTENTS

IC BLOCK DIAGRAMS & PIN DESCRIPTION	2-12 ~ 2-34
DIAGRAMS	2-35
1. BLOCK DIAGRAM	2-35
2. WIRING DIAGRAM	2-37
3. SCHEMATIC DIAGRAM	2-39
● FRONT & μ -COM PART.....	2-39
● INPUT & VOLUME PART.....	2-41
● DSP & CODEC PART	2-43
● VIDEO PART	2-45
● AMP PART	2-47
● POWER PART.....	2-49
● DVD BACK-END PART	2-51

IC PIN FUNCTION (IC81 : TMP87PS71AF(OTP)-ANAM 1359DAT(MICOM))

PIN No.	SYMBOL	I/O	DESCRIPTION
1	OSD_H	I	OSD INPUT SENSING PORT
2	REMOTE	I	REMOTE CONTROL DATA INPUT PORT
3	RDS_CK	O	CLK/DATA PORT FOR RDS IC(SA6579TV1)
4	RDS_DA	I	
5	F_MUTE	O	FUNCTION MUTE CONTROL OUTPUT PORT("H")
6	EVOL_DA	O	DATA / CLK / CHIP ENABLE CONTROL PORT FOR ELECTRONIC VOL. IC(M62446AFP)
7	EVOL_CK	O	
8	EVOL_CE	O	
9	TEST	-	
10	FUNC_A	I	FUNCTION SELECTOR (ENCODER) CONTROL PORT
11	FUNC_B	I	
12	RESET		RESET INPUT PORT("L")
13	X-IN	I	8MHz CRYSTAL CONNECTOR PORT
14	X-OUT	O	
15	VSS(GND)		DEVICE GND PORT
16	BACKUP	I	BACKUP MODE CONTROL PORT("L")
17	MREQ		DVD INTERFACE
18	FREQ		DVD INTERFACE
19	SCKO		DVD INTERFACE
20	DVD_IN		DVD INTERFACE
21	DVD_OUT		DVD INTERFACE
22	CLK1	O	CLK OUTPUT PORT FOR AK4586, CS49326, LC7476 & NJU3713
23	CS_CE	O	CHIP ENABLE PORT FOR CS49326
24	DATA1	O	DATA OUTPUT PORT FOR AK4586, CS49326, LC74763 & NJM3713
25	AK_CE	O	CHIP ENABLE PORT FOR AK4586
26	OSD_CE	O	CHIP ENABLE PORT FOR OSD IC(LC74763)
27	POWER	O	POWER ON CONTROL PORT("H")
28	PLL_DIN	I	PLL DATA INPUT PORT
29	FUNC_CE	O	CHIP ENABLE PORT FOR FUNCTION IC(TC9163/9164)
30	CLK2	O	CLK OUTPUT PORT FOR PLL & FUNCTION IC
31	DATA2	O	DATA OUTPUT PORT FOR PLL & FUNCTION IC
32	PLL_CE	O	PLL CHIP ENABLE PORT
33	+5V	I	POWER SUPPLY PORT
34~44	VFL GRID	O	VFL GRID CONTROL PORT
45~61	VFL SEGMENT	O	VFL SEGMENT CONTROL PORT
62~65	OPTION/VFL SEG.	O	OPTION CONTROL / VFL SEGMENT CONTROL PORT
66	-VKK	I	VFL POWER SUPPLY PORT(-30V)
67	OPTION	I	OPTION CONTROL PORT
68	H/P_IN	I	HEADPHONE IN/OUT SENSING PORT
69	PROTECT	I	PROTECT INPUT PORT("L")
70	STEREO	I	TUNER STEREO SENSING PORT
71	TUNED	I	TUNER TUNED SENSING PORT
72	VOL_B	I	MASTER VOLUME UP/DOWN CONTROL PORT
73	VOL_A	I	
74	CS_INTREQ	I	INTERRUPT REQUEST INPUT PORT FROM CS49326
75	CS/AK_DOUT	I	DATA INPUT PORT FROM AK4586 & CS49326
76~78	KEY_IN	I	KEY CONTROL INPUT PORT
79	CS_RST	O	RESET OUTPUT PORT FOR CS493263
80	EXP_CE	O	CHIP ENABLE PORT FOR NJU3713

u-COM IC PIN ASSIGNMENT & BLOCK DIAGRAM

PIN ASSIGNMENTS (TOP VIEW)

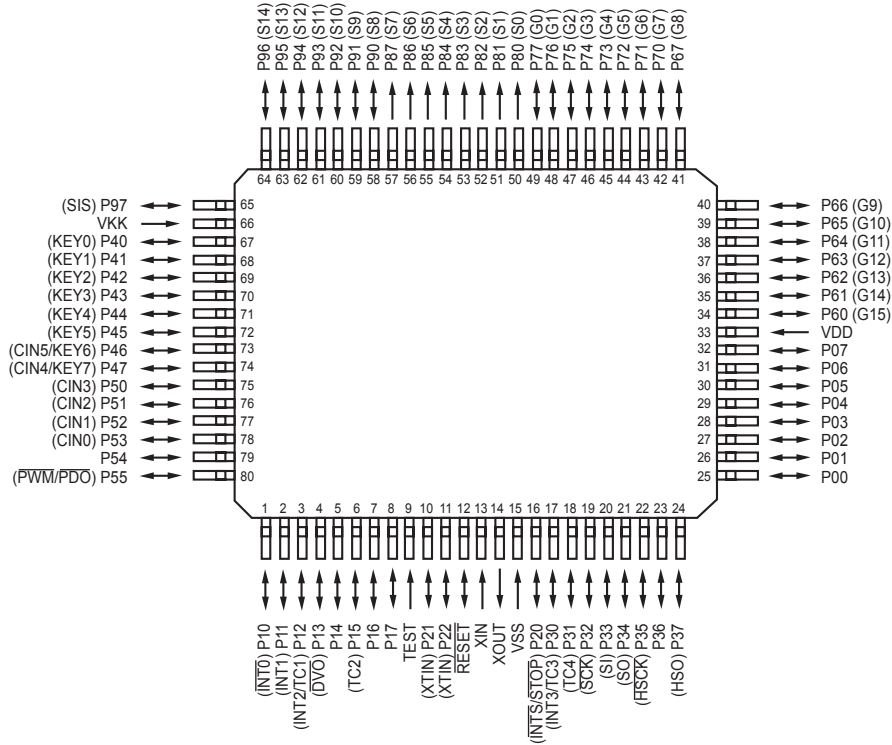

BLOCK DIAGRAM

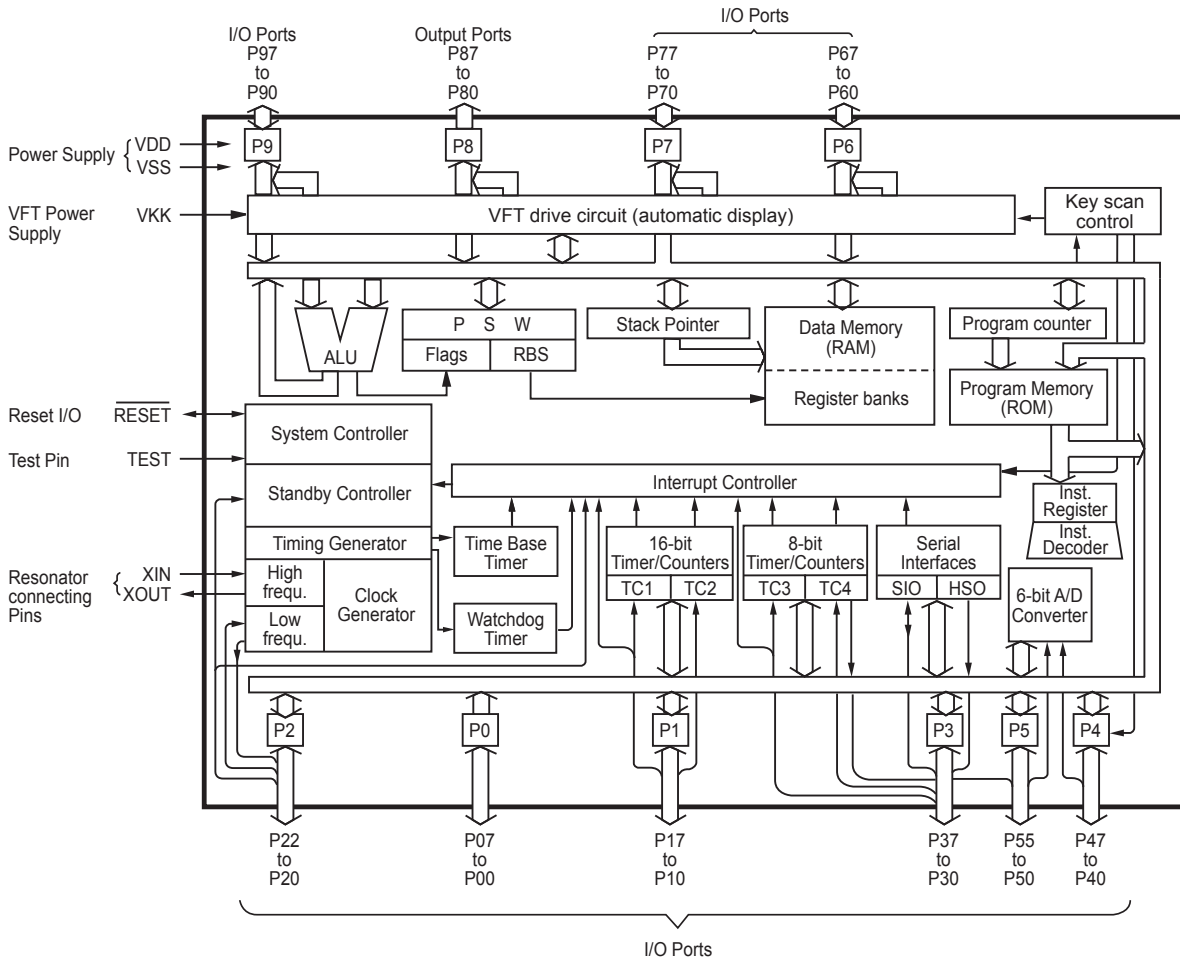

PIN ASSIGNMENT.(IC41: CS493264)

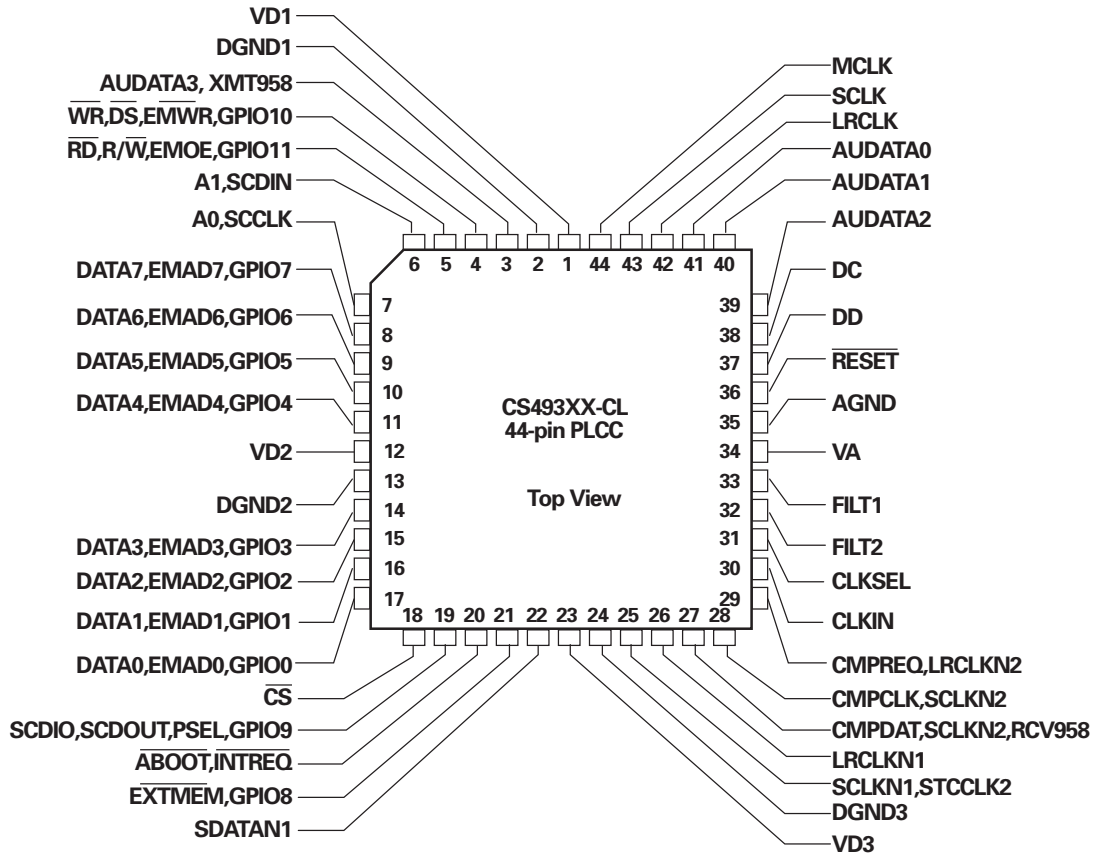

(TOP VIEW)

BLOCK DIAGRAM(IC41: CS493264)

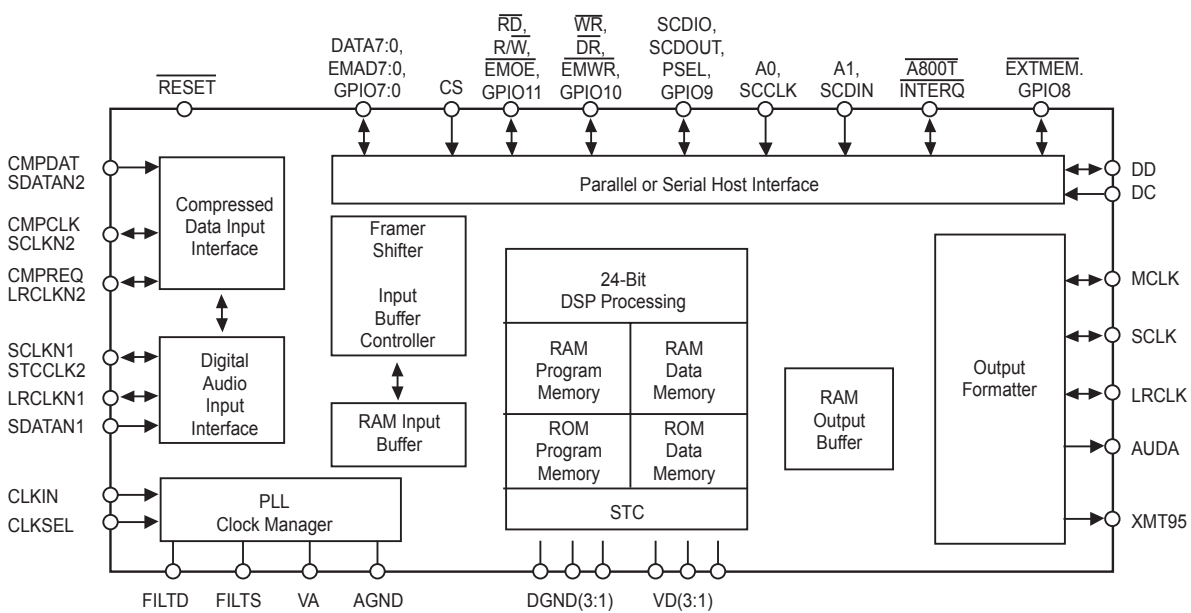

AUDIO DSP(CS49326 : IC41)

PIN No.	Pin Name	I/O	Function
1,12,23	+VD1	-	Digital Power supply. Normally +2.5v
2,13,24	DGND	-	Digital Ground
3	AUD3	O	SPDIF transmitter output/Digital audio output(N.C)
4	WR	I	Host write strobe pin(connected to GND with an external resistor)
5	RD	I	Host parallel output enable pin(pulled up with an external resistor)
6	CS_DA	I	SPI Serial data input pin
7	CS_CK	I	Serial control clock input pin
8	EMAD7	I/O	Serial data IN/OUTPUT pins(pulled up with an external resistor)
9	EMAD6	I/O	
10	EMAD5	I/O	
11	EMAD4	I/O	
14	EMAD3	I/O	
15	EMAD2	I/O	
16	EMAD1	I/O	
17	EMAD0	I/O	
18	CS_CE	I	Host parallel chip select pin
19	SCDIO(AK_DOUT)	O	Serial control port data output pin
20	INTREQ	O	Control port interrupt request output pin
21	EXTMEM	I/O	External Memory Chip Selector(pulled up with an external resistor)
22	SDATAN1(SDI)	I	PCM audio data input number 1 pin
25	SCLKN1(BICK)	I	PCM audio input bit clock pin
26	LRCLKN1(LRCK)	I	PCM audio input sample rate clock pin
27	CMPDAT(SDI)	I	PCM audio data input number 2 pin
28	CMPCLK(BICK)	I	PCM audio input bit clock pin
29	CREQ(LRCK)	I	PCM audio input sample rate clock pin
30	CLKIN(XIN)	I	Master clock input(used external clock)
31	CLKSEL(GND)	I	DSP clock mode select pin: connect the GND
32	FILT1		Connects to an external filter for the on-chip phase-locked loop
33	FILT1		Connects to an external filter for the on-chip phase-locked loop
34	+2.5V	-	Analog Power supply for clock generator . Normally +2.5V
35	AGND	-	Analog ground supply for clock generator PLL.
36	RESET(CS_RST)	I	Master reset input pin
37	DBDATA	-	Reserved pin and should be pulled up with an external resistor.
38	DBCLK	-	Reserved pin and should be pulled up with an external resistor.
39	AUD2(SDO2)	O	PCM multi-format digital-audio data output2 pin
40	AUD1(SDO1)	O	PCM multi-format digital-audio data output1 pin
41	AUD0(SDO0)	O	PCM multi-format digital-audio data output0 pin
42	LRCLK	I	Audio output sample rate clock pin
43	SCLK(BICK)	I	Audio output bit clock pin
44	MCLK	I	Audio master clock output pin

■ NJU3713
 (IC28 : EXPANDER / MAIN)

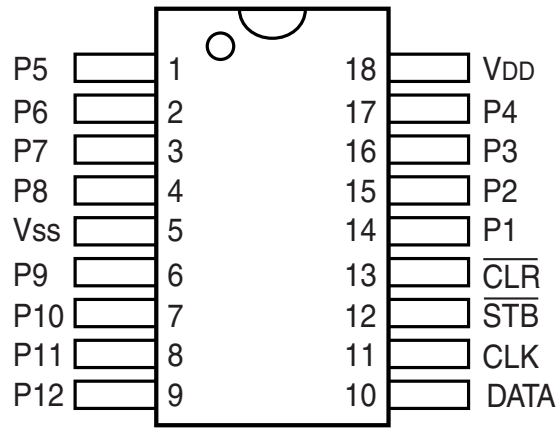

■ BLOCK DIAGRAM

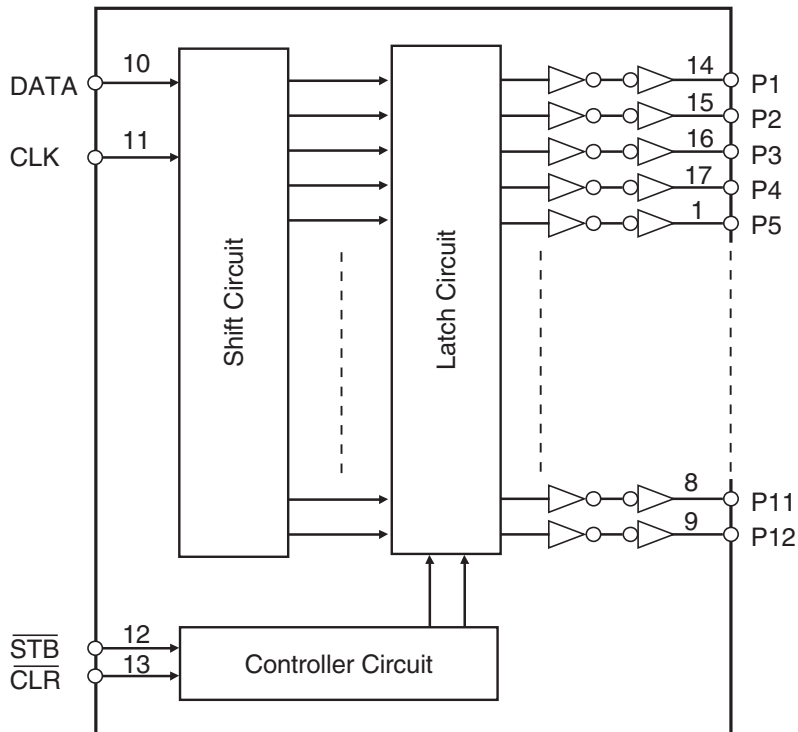

PIN ASSIGNMENT (IC42: AK4586)

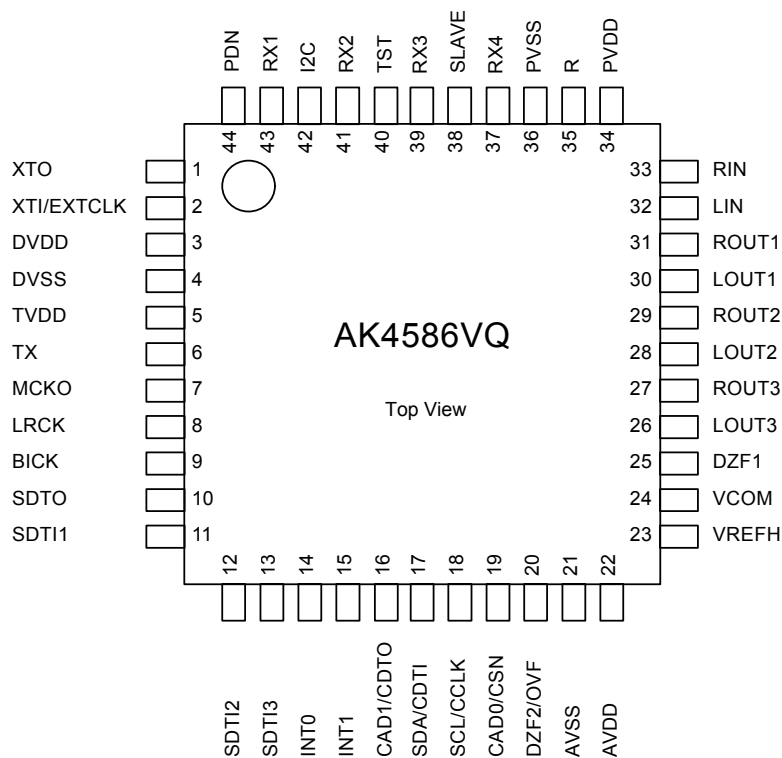

BLOCK DIAGRAM (IC42: AK4586)

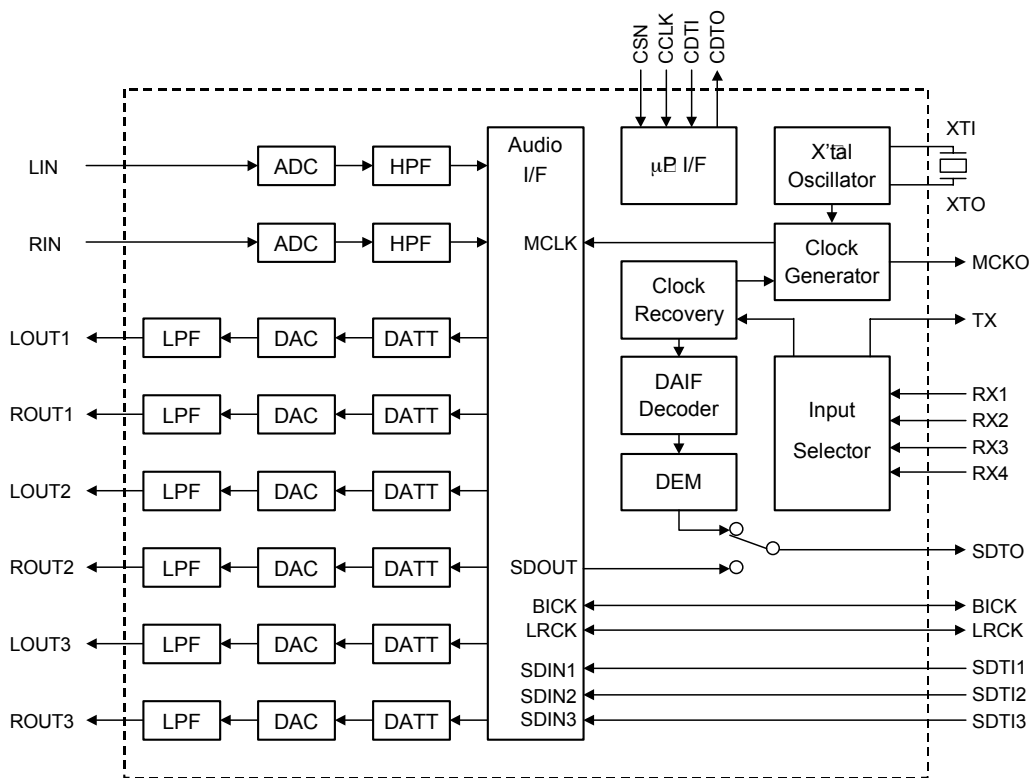

PIN/FUNCTION (IC42: AK4586)

No.	Pin Name	I/O	Function
1	XTO	O	X'tal Output Pin
2	XTI	I	X'tal Input Pin
	EXTCLK	I	External Master Clock Input Pin
3	DVDD	-	Digital Power Supply Pin, 4.5V 5.5V
4	DVSS	-	Digital Ground Pin, 0V
5	TVDD	-	Output Buffer Power Supply Pin, 2.7V 5.5V
6	TX	O	Transmit channel (through data) Output Pin
7	MCKO	O	Master Clock Output Pin
8	LRCK	I/O	Input/Output Channel Clock Pin
9	BICK	I/O	Audio Serial Data Clock Pin
10	SDTO	O	Audio Serial Data Output Pin
11	SDTI1	I	DAC1 Audio Serial Data Input Pin
12	SDTI2	I	DAC2 Audio Serial Data Input Pin
13	SDTI3	I	DAC3 Audio Serial Data Input Pin
14	INT0	O	Interrupt 0 pin
15	INT1	O	Interrupt 1 pin
16	CDTO	O	Control Data Output Pin in 4-wire serial control mode
	CAD1	I	Chip Address 1 Pin in I ² C bus control mode
17	CDTI	I	Control Data Input Pin in 4-wire serial control mode
	SDA	I/O	Control Data Input/Output Pin in I ² C bus control mode
18	CCLK	I	Control Data Clock Pin in 4-wire serial control mode
	SCL	I	Control Data Clock Pin in I ² C bus control mode
19	CSN	I	Chip Select Pin in 4-wire serial control mode
	CAD0	I	Chip Address 0 Pin in I ² C bus control mode
20	DZF2	O	Zero Input Detect 2 Pin (Note 1) When the input data of the group 1 follow total 8192 LRCK cycles with "0" input data, this pin goes to "H".
	OVF	O	Analog Input Overflow Detect Pin (Note 2) This pin goes to "H" if the analog input of Lch or Rch is overflows.
21	AVSS	-	Analog Ground Pin, 0V
22	AVDD	-	Analog Power Supply Pin, 4.5V 5.5V
23	VREFH	I	Positive Voltage Reference Input Pin, AVDD
24	VCOM	O	Common Voltage Output Pin, AVDD/2 Large external capacitor around 2.2μF is used to reduce powersupply noise.
25	DZF1	O	Zero Input Detect 1 Pin (Note 1) When the input data of the group 1 follow total 8192 LRCK cycles with "0" input data, this pin goes to "H".
26	LOUT3	O	DAC3 Lch Analog Output Pin
27	ROUT3	O	DAC3 Rch Analog Output Pin
28	LOUT2	O	DAC2 Lch Analog Output Pin
29	ROUT2	O	DAC2 Rch Analog Output Pin
30	LOUT1	O	DAC1 Lch Analog Output Pin
31	ROUT1	O	DAC1 Rch Analog Output Pin
32	LIN	I	Lch Analog Input Pin
33	RIN	I	Rch Analog Input Pin
34	PVDD	-	PLL Power Supply Pin, 4.5V 5.5V
35	R	-	External Resistor Pin 18Ω +/-1% resistor to PVSS externally.
36	PVSS	-	PLL Ground Pin, 0V
37	RX4	I	Receiver Channel 4 Pin (Internal biased pin)
38	SLAVE	I	Slave Mode Pin "L": Master mode or Slave mode, "H": Slave mode
39	RX3	I	Receiver Channel 3 Pin (Internal biased pin)
40	TST	I	Test Pin This pin should be connected to DVSS.
41	RX2	I	Receiver Channel 2 Pin (Internal biased pin)
42	I2C	I	Control Mode Select Pin "L": 4-wire Serial, "H": I ² C Bus
43	RX1	I	Receiver Channel 1 Pin (Internal biased pin)
44	PDN	I	Power-Down & Reset Pin When "L", the AK4586 is powered-down, all output pins go to "L" and the control registers are reset to default state. If the state of CAD1-0 changes, then the AK4586 must be reset by PDN.

■ NJM2296M (VIDEO SW / IC51, 52, 53)

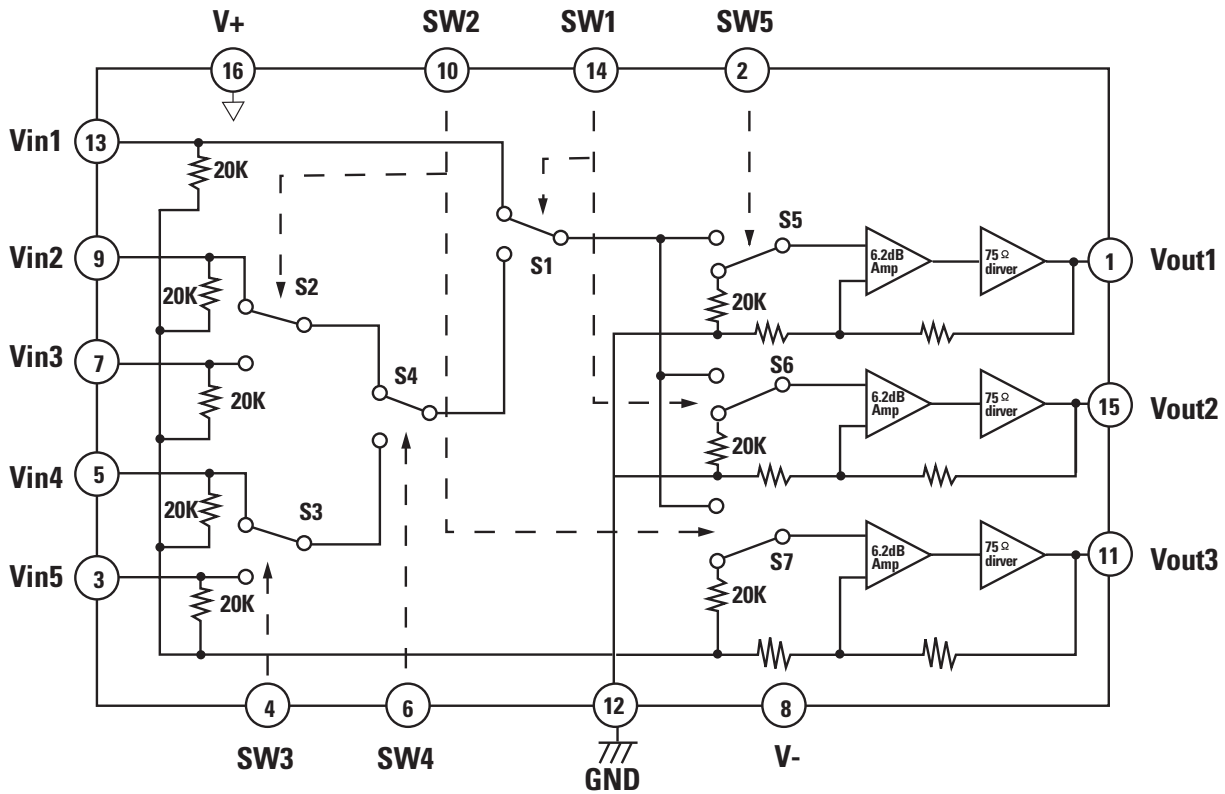

* Normally mute
 Above circuits show that the switches are set at low.

■ OPA2134UA / NJM 2068MD (OP AMP / IC16~21, IC45~53)

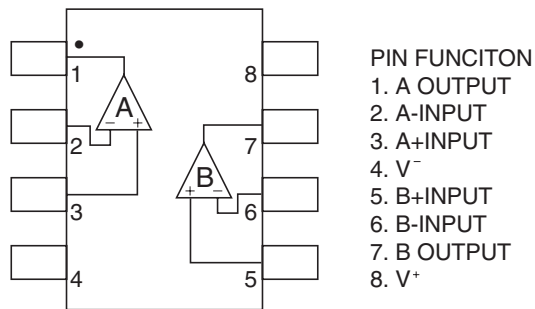

TC9164AF (FUNCTION IC11)

■ BLOCK DIAGRAM

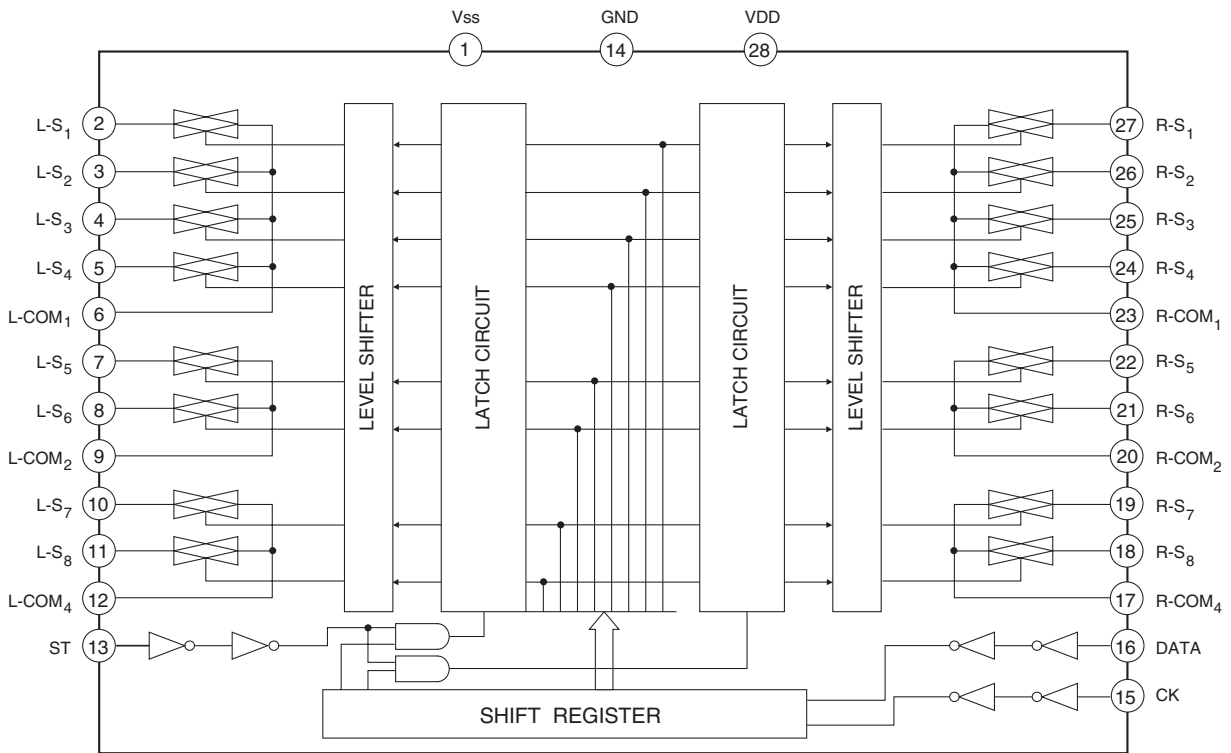

TC9162AF (FUNCTION IC12)

■ BLOCK DIAGRAM

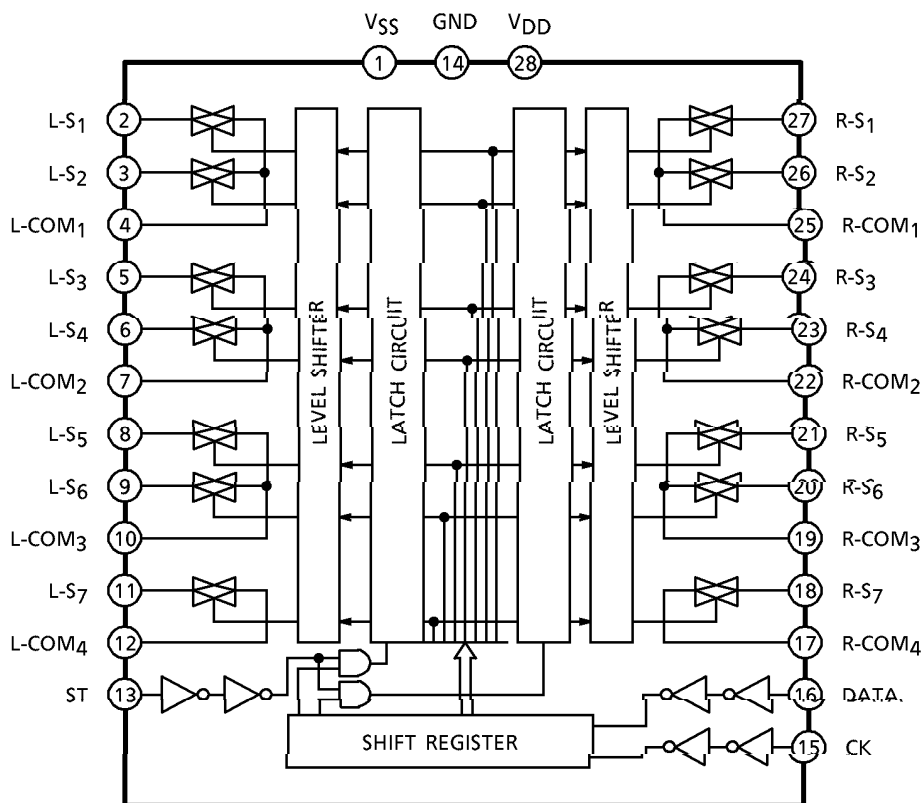

■ M62446FP (ELECTRONIC VOLUME/INPUT : IC13)

SYSTEM BLOCK DIAGRAM

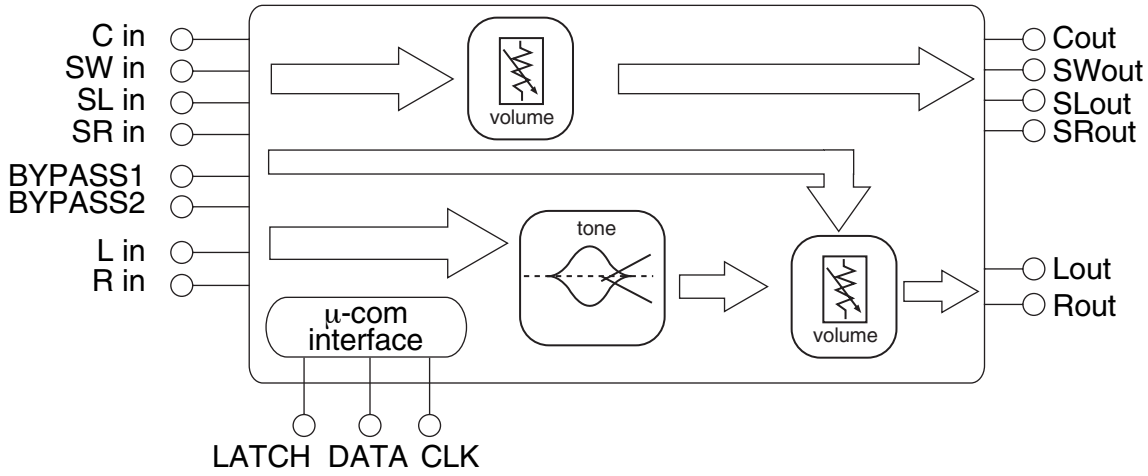

PIN CONFIGURATION AND IC INTERNAL BLOCK DIAGRAM

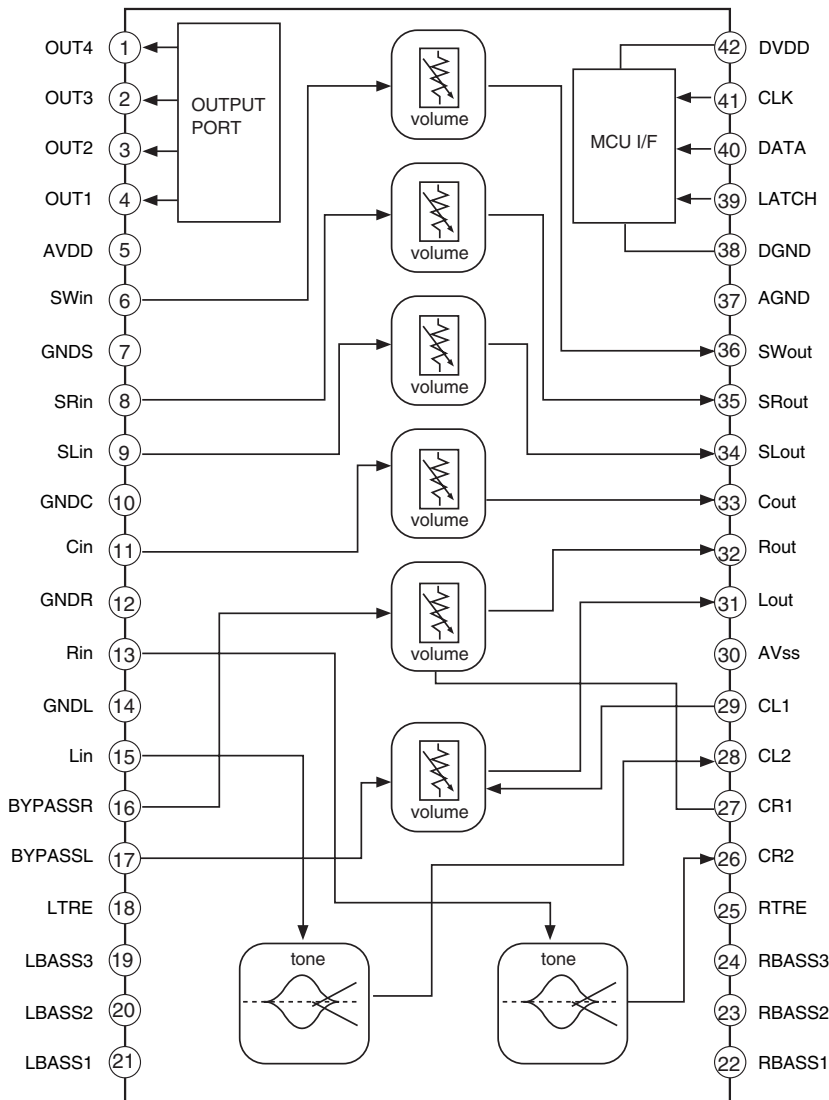

■ LC74763 (OSD IC54)

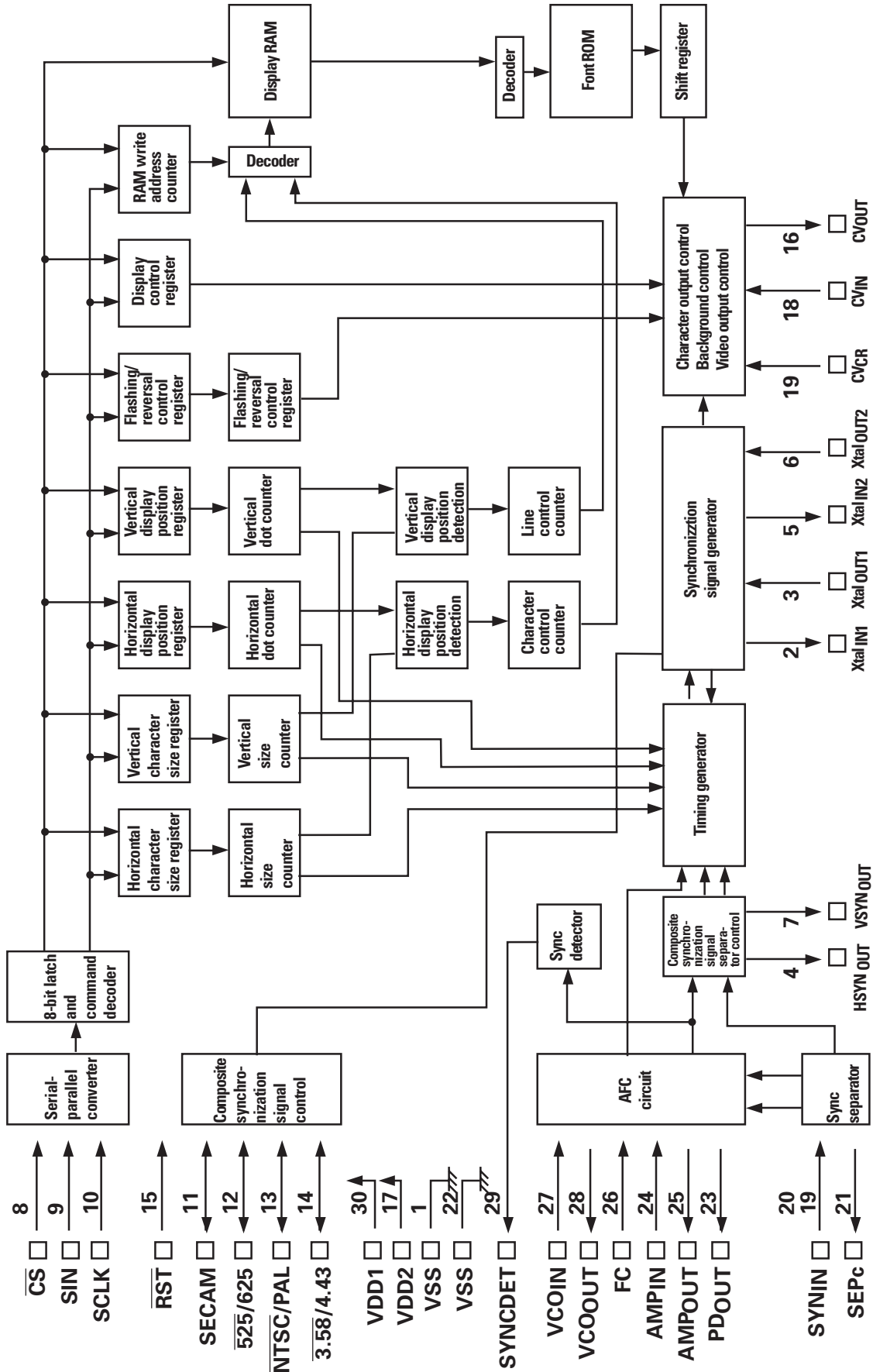

■ SAA6579TV1 (RDS FILTER IC82)

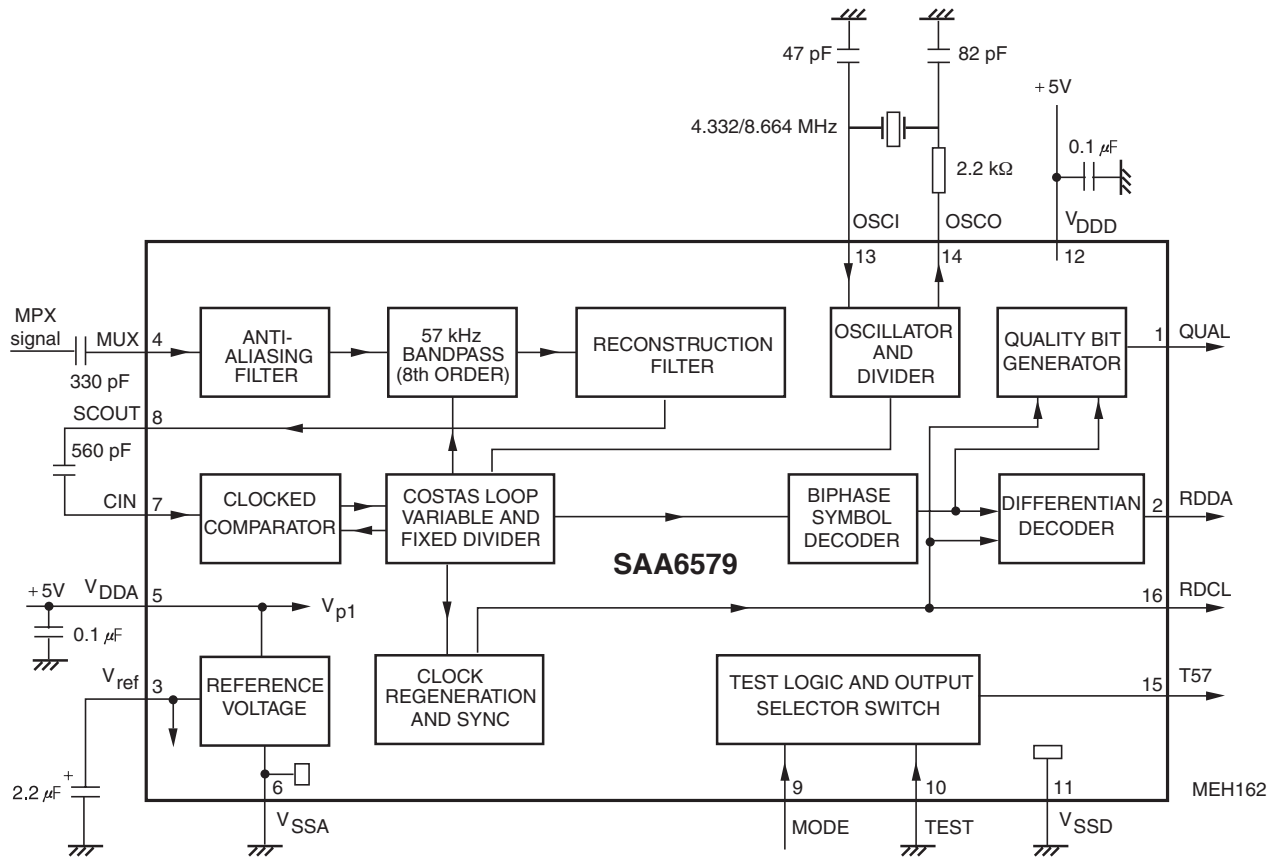

■ TC74 HCU04AFN (INVERTER IC31)

■ 74LCX08 (IC15: AND GATE)
74VHC08 (IC83 : AND GATE)

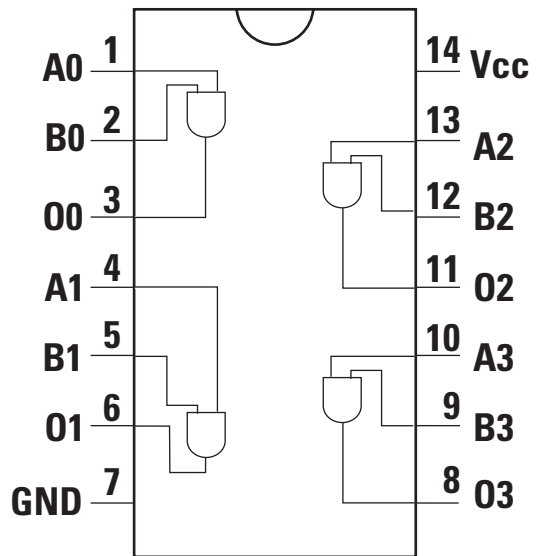
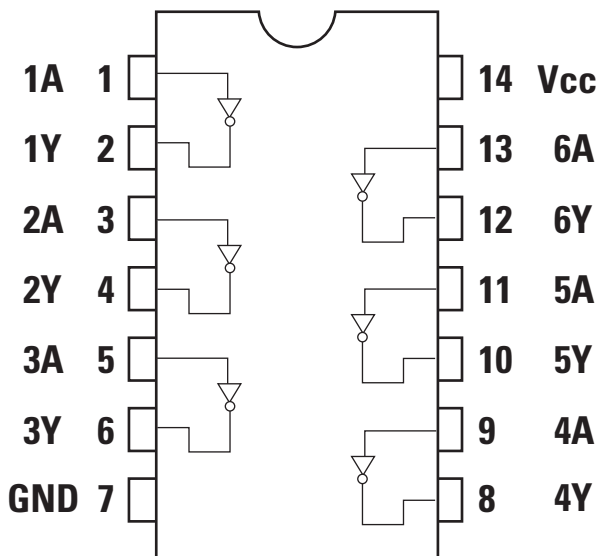

■ HY57V161610D (IC10, IC11 : SDRAM)

FUNCTIONAL BLOCK DIAGRAM

1Mx16 Synchronous DRAM

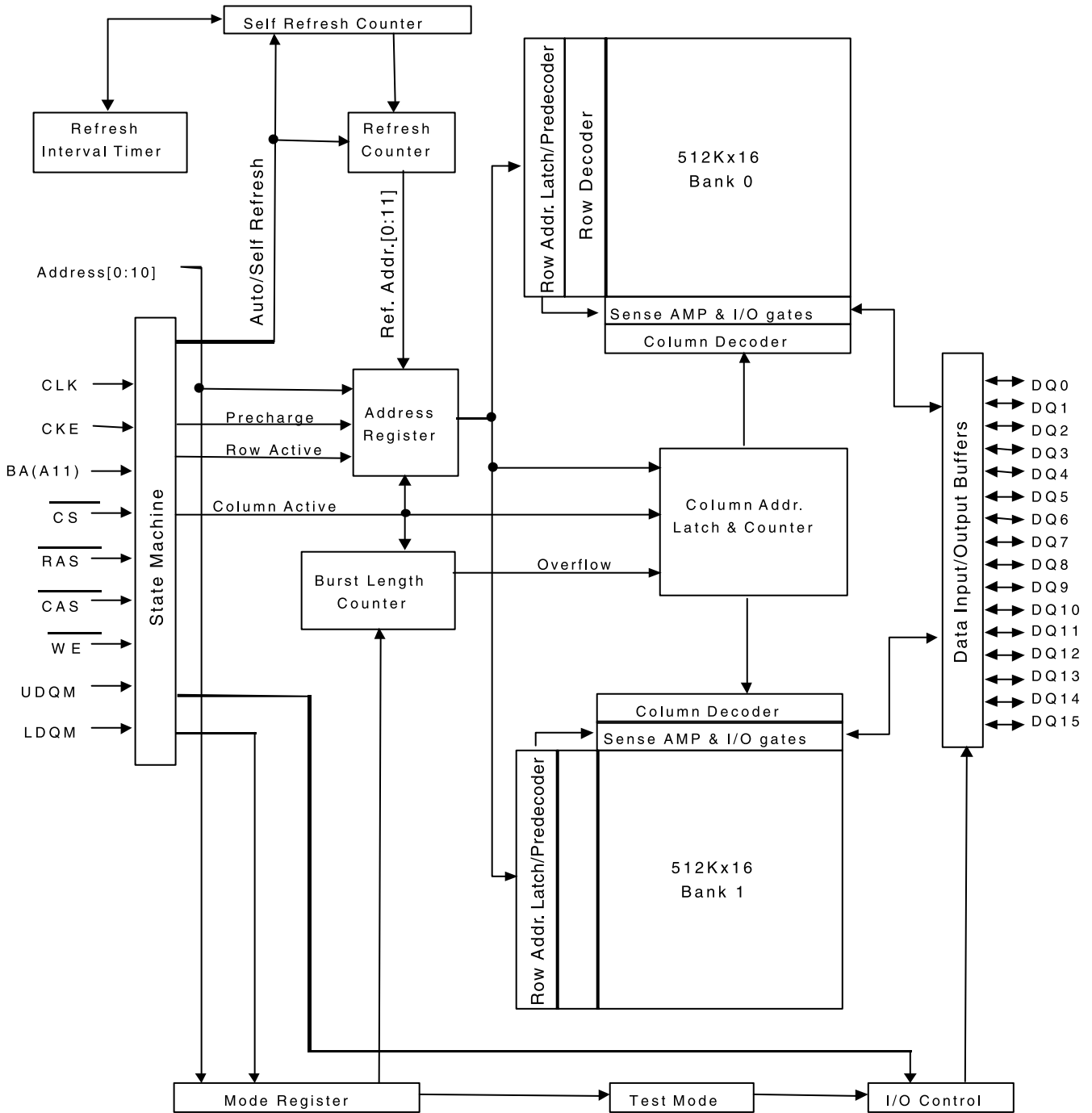

■ HY57V161610D

PIN CONFIGURATION

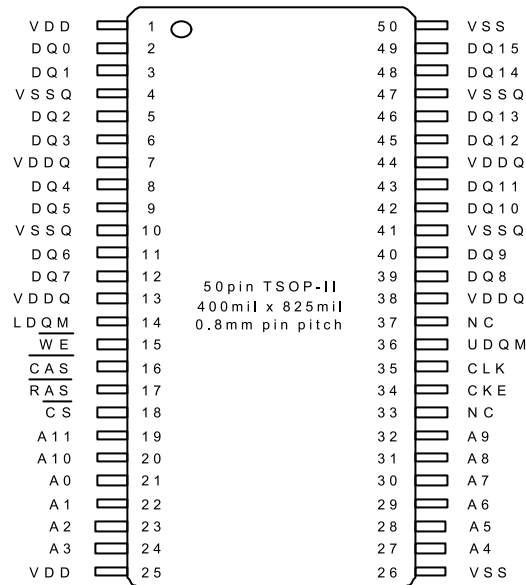

PIN DESCRIPTION

PIN	PIN NAME	DESCRIPTION
CLK	Clock	The system clock input. All other inputs are referenced to the SDRAM on the rising edge of CLK.
CKE	Clock Enable	Controls internal clock signal and when deactivated, the SDRAM will be one of the states among power down, suspend or self refresh.
$\overline{\text{CS}}$	Chip Select	Command input enable or mask except CLK, CKE and DQM
BA	Bank Address	Select either one of banks during both $\overline{\text{RAS}}$ and $\overline{\text{CAS}}$ activity.
A0 ~ A10	Address	Row Address : RA0 ~ RA10, Column Address : CA0 ~ CA7 Auto-precharge flag : A10
$\overline{\text{RAS}}$, $\overline{\text{CAS}}$, $\overline{\text{WE}}$	Row Address Strobe, Column Address Strobe, Write Enable	$\overline{\text{RAS}}$, $\overline{\text{CAS}}$ and $\overline{\text{WE}}$ define the operation. Refer function truth table for details
LDQM, UDQM	Data Input/Output Mask	DQM control output buffer in read mode and mask input data in write mode
DQ0 ~ DQ15	Data Input/Output	Multiplexed data input / output pin
VDD/VSS	Power Supply/Ground	Power supply for internal circuit and input buffer
VDDQ/VSSQ	Data Output Power/Ground	Power supply for DQ
NC	No Connection	No connection

■ SWAN-2™ (ES4318 : IC01) FUNCTIONAL DESCRIPTION

The following figure shows the internal block diagram for the Swan-2™ ES4318.

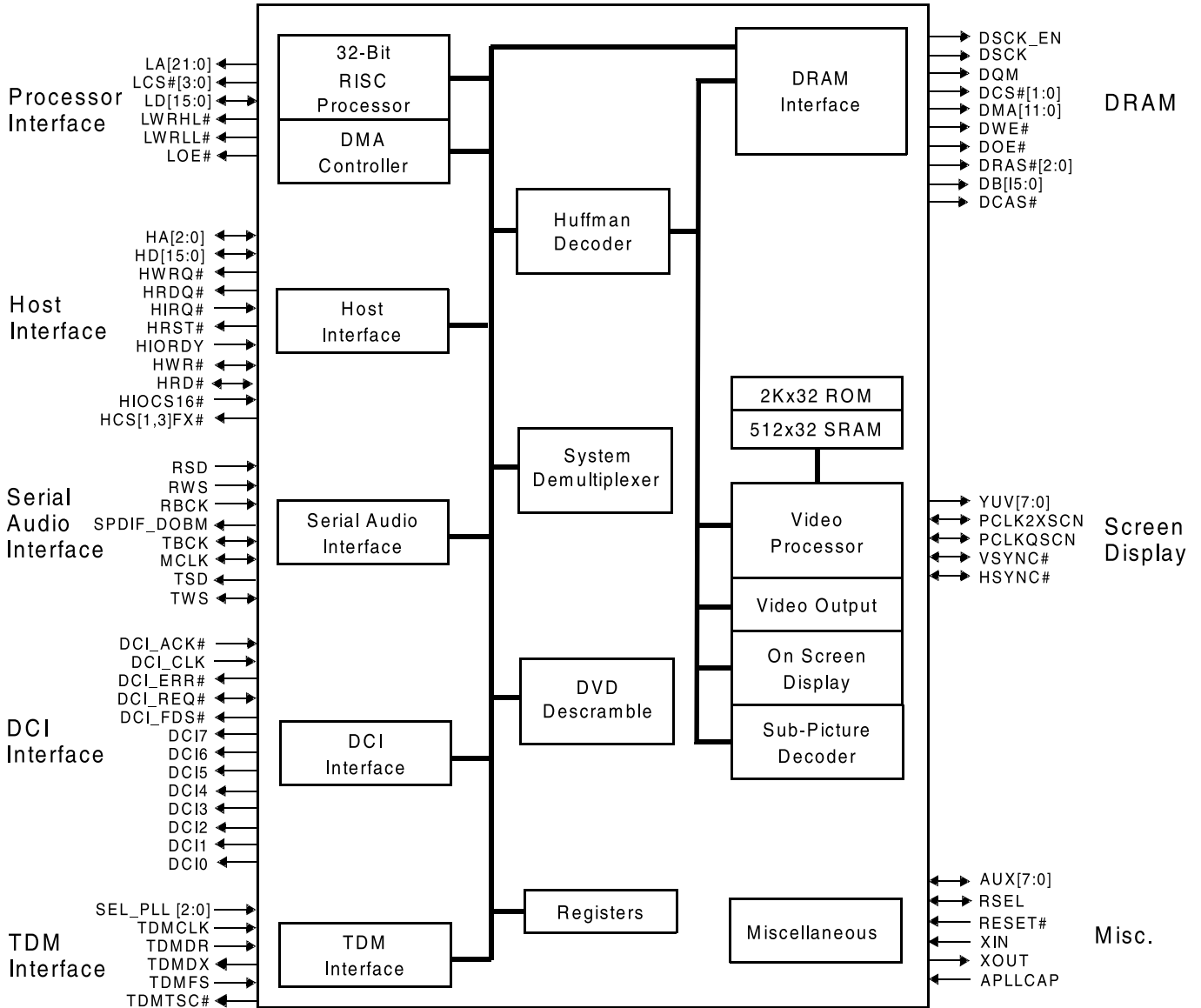

PIN GEOGRAPHY

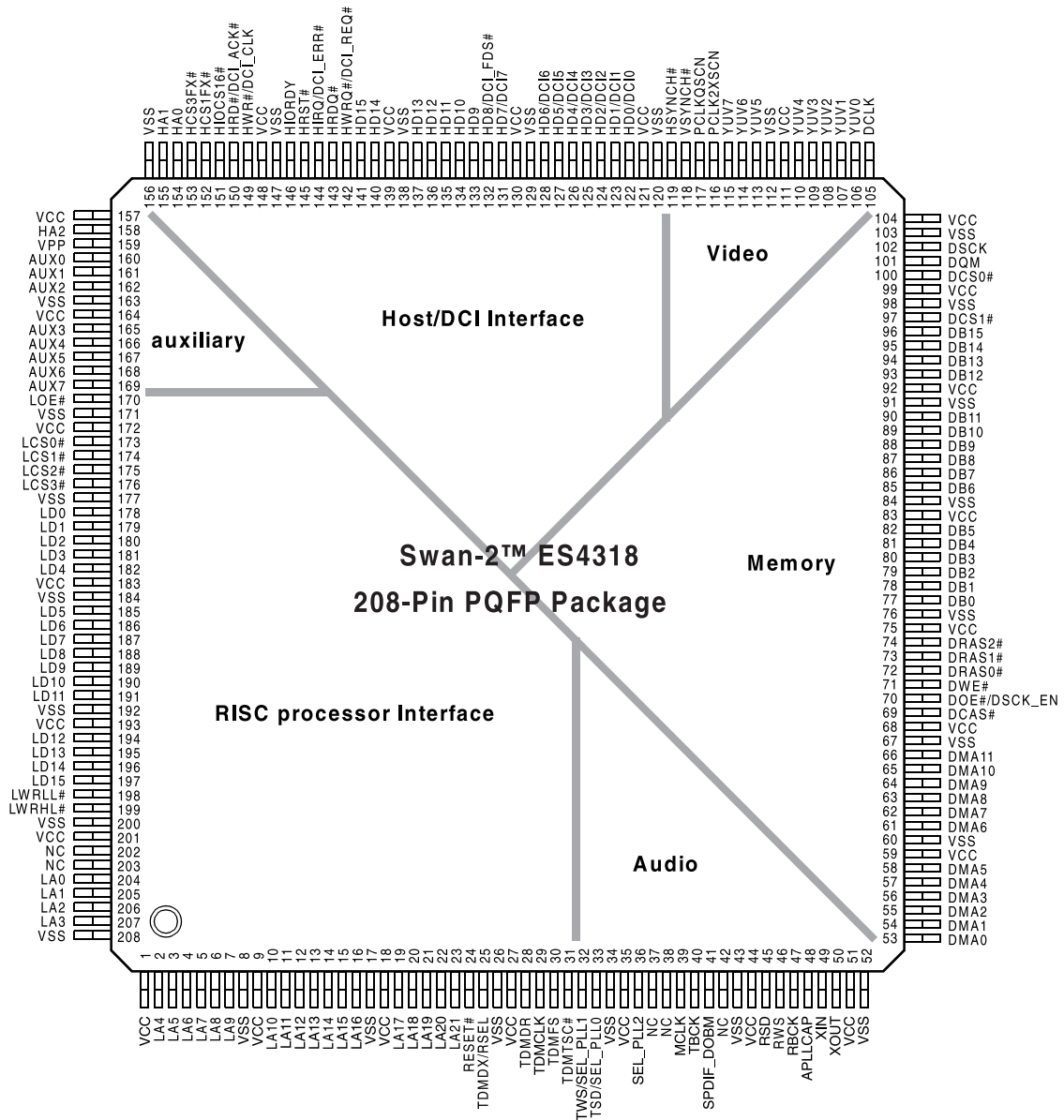

■ SWAN-2™ ES4318 PIN DESCRIPTION

Name	Number	I/O	Definition																				
VCC	1, 9, 18, 27, 35, 44, 51, 59, 68, 75, 83, 92, 99, 104, 111, 121, 130, 139, 148, 157, 164, 172, 183, 193, 201	I	3.65 V ± 150 mv.																				
LA[21:0]	23:19, 16:10, 7:2, 207:204	O	Device address output.																				
VSS	8, 17, 26, 34, 43, 52, 60, 67, 76, 84, 91, 98, 103, 112, 120, 129, 138, 147, 156, 163, 171, 177, 184, 192, 200, 208	I	Ground.																				
RESET#	24	I	Reset input, active low.																				
TDMDX		O	TDM transmit data.																				
RSEL	25	I	ROM Select <table border="1"> <thead> <tr> <th>RSEL</th> <th>Selection</th> <th>OM</th> <th>R</th> </tr> </thead> <tbody> <tr> <td>0</td> <td>16-bit</td> <td></td> <td></td> </tr> <tr> <td>1</td> <td>8-bit</td> <td>ROM</td> <td></td> </tr> </tbody> </table>	RSEL	Selection	OM	R	0	16-bit			1	8-bit	ROM									
RSEL	Selection	OM	R																				
0	16-bit																						
1	8-bit	ROM																					
TDMDR	28	I	TDM receive data.																				
TDMCLK	29	I	TDM clock input.																				
TDMFS	30	I	TDM frame synch.																				
TDMTSC#	31	O	TDM output enable, active low.																				
TWS		O	Audio transmit frame sync.																				
SEL_PLL1	32	I	Select PLL1.																				
TSD		O	Audio transmit serial data port.																				
SEL_PLL0	33	I	Select PLL0. <table border="1"> <thead> <tr> <th>SEL_PLL2</th> <th>SEL_PLL0</th> <th>Clock Output</th> <th></th> </tr> </thead> <tbody> <tr> <td>0</td> <td>0</td> <td>2.5 x DCLK</td> <td></td> </tr> <tr> <td>0</td> <td>1</td> <td>3 DCLK</td> <td>x</td> </tr> <tr> <td>1</td> <td>0</td> <td>3.5 x DCLK</td> <td></td> </tr> <tr> <td>1</td> <td>1</td> <td>4 DCLK</td> <td>x</td> </tr> </tbody> </table>	SEL_PLL2	SEL_PLL0	Clock Output		0	0	2.5 x DCLK		0	1	3 DCLK	x	1	0	3.5 x DCLK		1	1	4 DCLK	x
SEL_PLL2	SEL_PLL0	Clock Output																					
0	0	2.5 x DCLK																					
0	1	3 DCLK	x																				
1	0	3.5 x DCLK																					
1	1	4 DCLK	x																				
SEL_PLL2	36		Select PLL2. See the table for pin number 33.																				
MCLK	39	I/O	Audio master clock for audio DAC.																				
TBCK	40	I/O	Audio transmit bit clock.																				
SPDIF_DOBM	41	O	S/PDIF (IEC958) Format Output.																				
RSD	45	I	Audio receive serial data.																				
RWS	46	I	Audio receive frame synch.																				
RBCK	47	I	Audio receive bit clock.																				
APLLCAP	48	I	Analog PLL Capacitor.																				
XIN	49	I	Crystal input.																				
XOUT	50	O	Crystal output.																				
DMA[11:0]	66:61, 58:53	O	DRAM address bus.																				
DCAS#	69	O	Column address strobe, active low.																				
DOE#	70	O	Output enable, active low.																				
DSCK_EN		I	Clock Enable, active low.																				
DWE#	71	O	DRAM write enable, active low.																				
DRAS[2:0]#	74:72	O	Row address strobe, active low.																				
DB[15:0]	96:93, 90:85, 82:77	I/O	DRAM data bus.																				
DCS[1:0]#	97, 100	O	SDRAM chip select [1:0], active low.																				
DQM	101	O	Data input/output mask.																				
DSCK	102	O	Clock to SDRAM.																				
DCLK	105	I	Clock Input (27 MHz)																				
YUV[7:0]	115:113, 110:106	O	8-bit YUV output.																				
PCLK2XSCN	116	I/O	2X pixel clock.																				
PCLKQSCN	117	I/O	Pixel clock.																				
VSYNCH#	118	I/O	Vertical synch for screen video interface, programmable for rising or falling edge, active low.																				
HSYNCH#	119	I/O	Horizontal sync for screen video interface, programmable for rising or falling edge, active low.																				
HD[15:0]	141:140, 137:131, 128:122	O	Host data bus.																				
HCS1FX#	152	O	Host select 1.																				
HCS3FX#	153	O	Host select 3.																				
HIOCS16#	151	I	Device 16-bit data transfer.																				
HA[2:0]	158, 155:154	I/O	Host address bus.																				
VPP	159	I	Peripheral protection voltage. See AppNote 2.																				
HWR#/DCI_ACK#	149	I,I	Host write/DCI Interface Acknowledge Signal, active low.																				
HRD#/DCI_CLK	150	I,I	Host read/DCI Interface Clock.																				
HD[15:0]	141:140, 137:131, 128:122	I/O	Host data bus.																				
HWRO#	142	O	Host write request.																				
HRDQ#	143	O	Host read request.																				
HIRQ	144	I/O	Host interrupt.																				
HRST#	145	O	Host reset.																				
HIORDY	146	I	Host I/O ready.																				
HWR#	149	O	Host write request.																				
AUX[7:0]	169:165, 162:160	I/O	Auxiliary ports.																				
LOE#	170	O	Device output enable, active low.																				
LCS[3:0]#	176:173	O	Chip select [3:0], active low.																				
LD[15:0]	197:194, 191:185, 182:178	I/O	Device data bus.																				
LWRL#	198	O	Device write enable, active low.																				
LWRHL#	199	O	Device write enable, active low.																				
NC	37, 38, 42, 203:202		No Connect pins. Leave open.																				

CS4955 (VIDEO ENCODER : IC14)

PIN DESCRIPTION

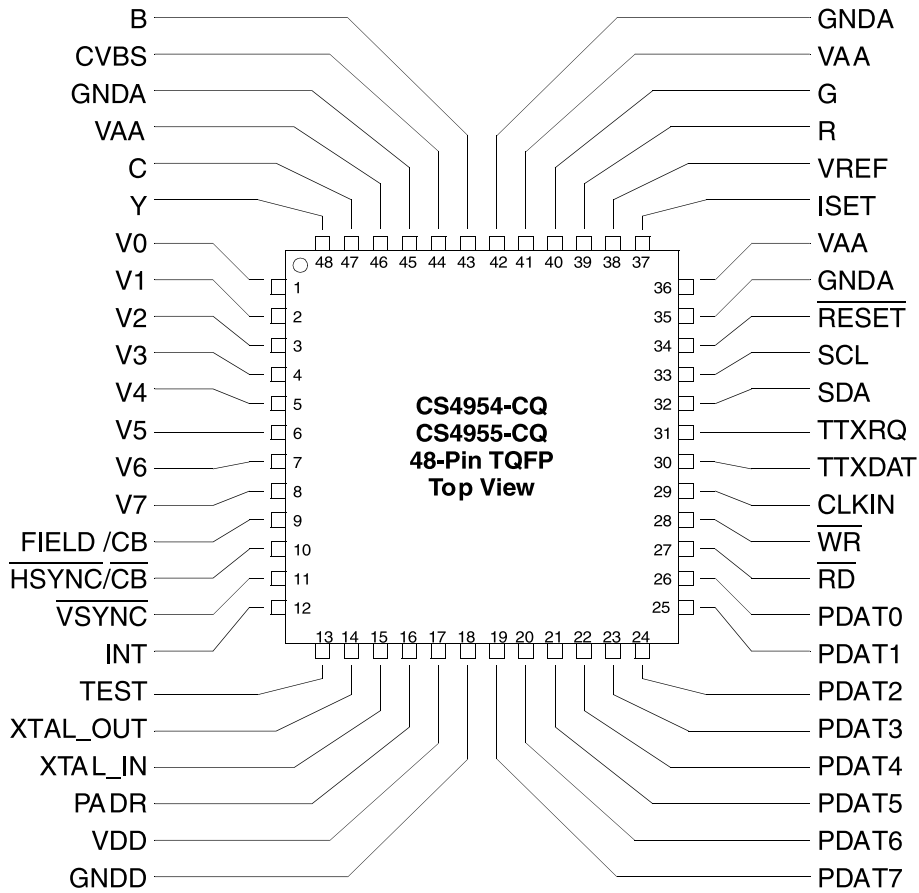

BLOCK DIAGRAM

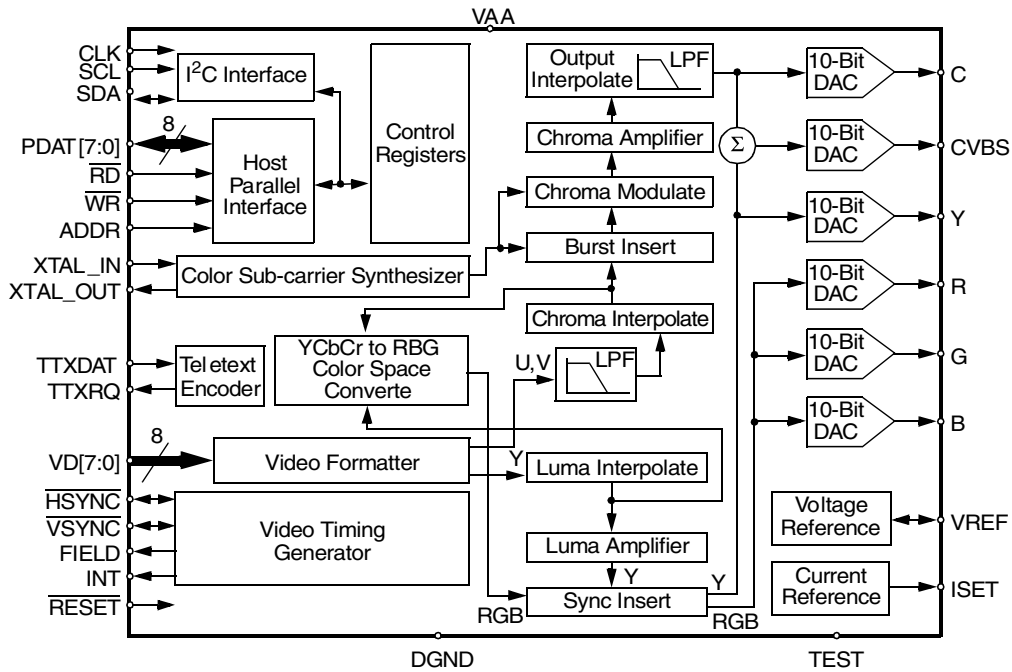

■ CS4955

Pin Name	Pin Number	Type	Description
V [7:0]	8, 7, 6, 5, 4, 3, 2, 1	IN	Digital video data inputs
CLK	29	IN	27 MHz input clock
PADDR	16	IN	Address enable line
XTAL_IN	15	IN	subcarrier crystal input
XTAL_OUT	14	OUT	subcarrier crystal output
HSYNC/CB	10	I/O	Active low horizontal sync, or composite blank signal
VSYN \bar{C}	11	I/O	Active low vertical sync.
FIELD/CB	9	OUT	Video field ID. Selectable polarity or composite blank
RD	27	IN	Host parallel port read strobe, active low
WR	28	IN	Host parallel port write strobe, active low
PDAT [7:0]	19, 20, 21, 22, 23, 24, 25, 26	I/O	Host parallel port/ general purpose I/O
SDA	32	I/O	I ² C data
SCL	33	IN	I ² C clock input
CVBS	44	CURRENT	Composite video output
Y	48	CURRENT	Luminance analog output
C	47	CURRENT	Chrominance analog output
R	39	CURRENT	Red analog output
G	40	CURRENT	Green analog output
B	43	CURRENT	Blue analog output
VREF	38	I/O	Internal voltage reference output or external reference input
ISET	37	CURRENT	DAC current set
TTXDAT	30	IN	Teletext data input
TTXRQ	31	OUT	Teletext request output
INT	12	OUT	Interrupt output, active high
RESET	34	IN	Active low master RESET
TEST	13	IN	TEST pin. Ground for normal operation
VAA	36, 41, 46	PS	+ 5 V or + 3.3 V supply (must be same as VDD)
GNDD	18	PS	Ground
VDD	17	PS	+5 V or 3.3 V supply (must be same as VAA)
GNDA	35, 42, 45	PS	Ground

HY29F400 (FLASH MEMORY : IC03)

■ PIN CONFIGURATIONS

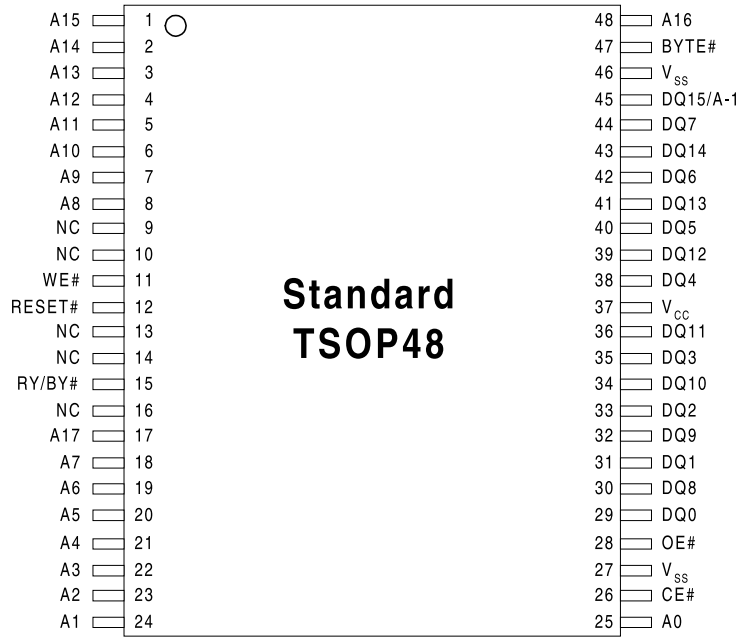

■ BLOCK DIAGRAM

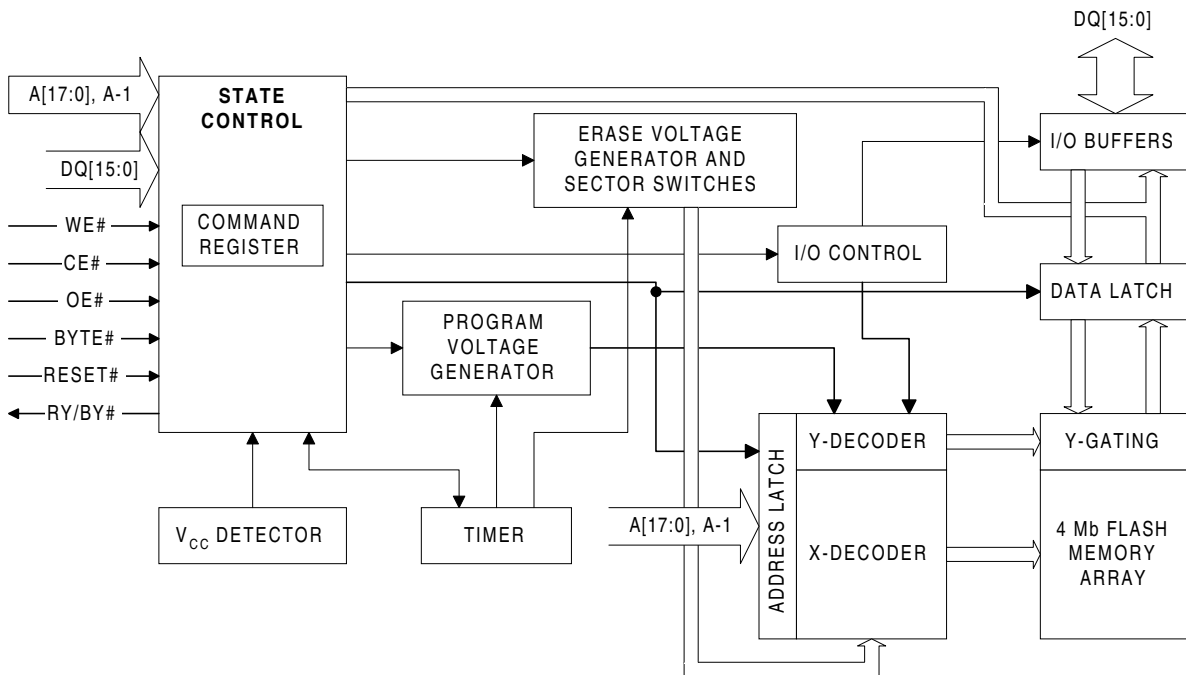

■ HY29F400

SIGNAL DESCRIPTIONS

Name	Type	Description
A[17:0]	Inputs	Address, active High. In Word mode, these 18 inputs select one of 262,144 (256K) words within the array for read or write operations. In Byte mode, these inputs are combined with the DQ15/A-1 input (LSB) to select one of 524,288 (512K) bytes within the array for read or write operations.
DQ[15]/A[-1], DQ[14:0]	Inputs/Outputs Tri-state	Data Bus, active High. In Word mode, these pins provide a 16-bit data path for read and write operations. In Byte mode, DQ[7:0] provide an 8-bit data path and DQ[15]/A[-1] is used as the LSB of the 19-bit byte address input. DQ[14:8] are unused and remain tri-stated in Byte mode.
BYTE#	Input	Byte Mode, active Low. Controls the Byte/Word configuration of the device. Low selects Byte mode, High selects Word mode.
CE#	Input	Chip Enable, active Low. This input must be asserted to read data from or write data to the HY29F400. When High, the data bus is tri-stated and the device is placed in the Standby mode.
OE#	Input	Output Enable, active Low. This input must be asserted for read operations and negated for write operations. BYTE# determines whether a byte or a word is read during the read operation. When High, data outputs from the device are disabled and the data bus pins are placed in the high impedance state.
WE#	Input	Write Enable, active Low. Controls writing of commands or command sequences in order to program data or erase sectors of the memory array. A write operation takes place when WE# is asserted while CE# is Low and OE# is High. BYTE# determines whether a byte or a word is written during the write operation.
RESET#	Input	Hardware Reset, active Low. Provides a hardware method of resetting the HY29F400 to the read array state. When the device is reset, it immediately terminates any operation in progress. The data bus is tri-stated and all read/write commands are ignored while the input is asserted. While RESET# is asserted, the device will be in the Standby mode.
RY/BY#	Output Open Drain	Ready/Busy Status. Indicates whether a write or erase command is in progress or has been completed. RY/BY# is valid after the rising edge of the final WE# pulse of a command sequence. It remains Low while the device is actively programming data or erasing, and goes High when it is ready to read array data.
V _{CC}	--	5-volt power supply.
V _{SS}	--	Power and signal ground.

EEPROM : IC13

■ PIN CONFIGURATION

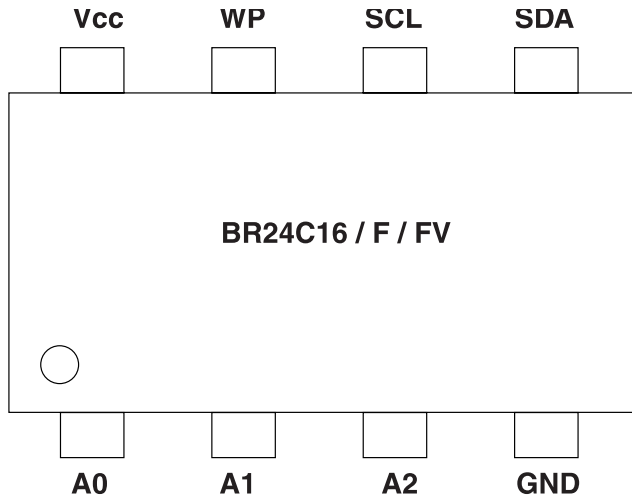

■ PIN NAME



Pin name	I / O	Function
V _{cc}		Power supply
GND		Ground (0V)
A0, A1, A2	I	Out of use. Please connect to GND.
SCL	I	Serial clock input
SDA	I / O	Slave and word address, serial data input, serial data output
WP	I	Write protect pin

* 1 An open drain output requires a pull-up resistor.

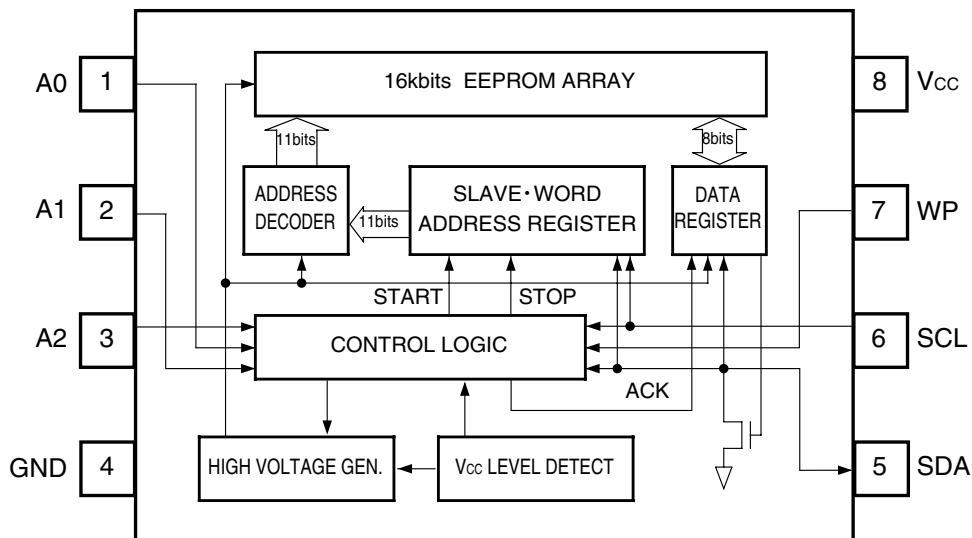
■ BLOCK DIAGRAM

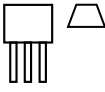

■ TRANSISTOR, REGULATOR IC BLOCK DIAGRAM

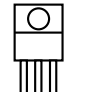
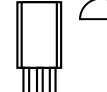
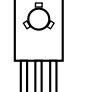
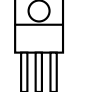
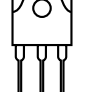
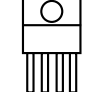
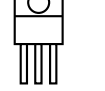
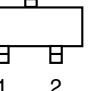
<p>TO-92S</p>  <p>1. Emitter 2. Collector 3. Base</p> <p>123</p> <p>KRA102M KRC102M KSC2785Y KSA1175Y</p>	<p>TO-92</p>  <p>1. Emitter 2. Collector 3. Base</p> <p>123</p> <p>KTC3200GR KSB811Y KTA1271Y KSA733 KTA1268GR</p>	<p>TO-220</p>  <p>1. INPUT 2. OUTPUT 3. GND</p> <p>123</p> <p>NJM7912FA</p>	<p>TO-92L</p>  <p>1. Emitter 2. Collector 3. Base</p> <p>123</p> <p>KSC2316Y KSA316Y</p>
<p>TO-126</p>  <p>1. Emitter 2. Collector 3. Base</p> <p>123</p> <p>KTC3114A KTA1360Y KTC3423Y</p>	<p>TO-220</p>  <p>1. INPUT 2. GND 3. OUTPUT</p> <p>123</p> <p>MC7812C MC7806C</p>	<p>TO-3P</p>  <p>1. Base 2. Collector 3. Emitter</p> <p>1 2 3</p> <p>2SB1559 2SD2389</p>	<p>TO-220</p>  <p>1. INPUT 2. OUTPUT 3. GND 4. CONTROL</p> <p>1234</p> <p>KIA78R05 KA78R05 KIA278R12 KA278R12 KIA278R06 KA278R06</p>
<p>TO-220</p>  <p>1. Base 2. Collector 3. Emitter</p> <p>123</p> <p>KTB1369Y KTD2061Y</p>	<p>SOT-23</p>  <p>1. Emitter 2. Base 3. Collector</p> <p>1 2 3</p> <p>KRA102S KRC102S KTA1304</p>		

1. BLOCK DIAGRAM

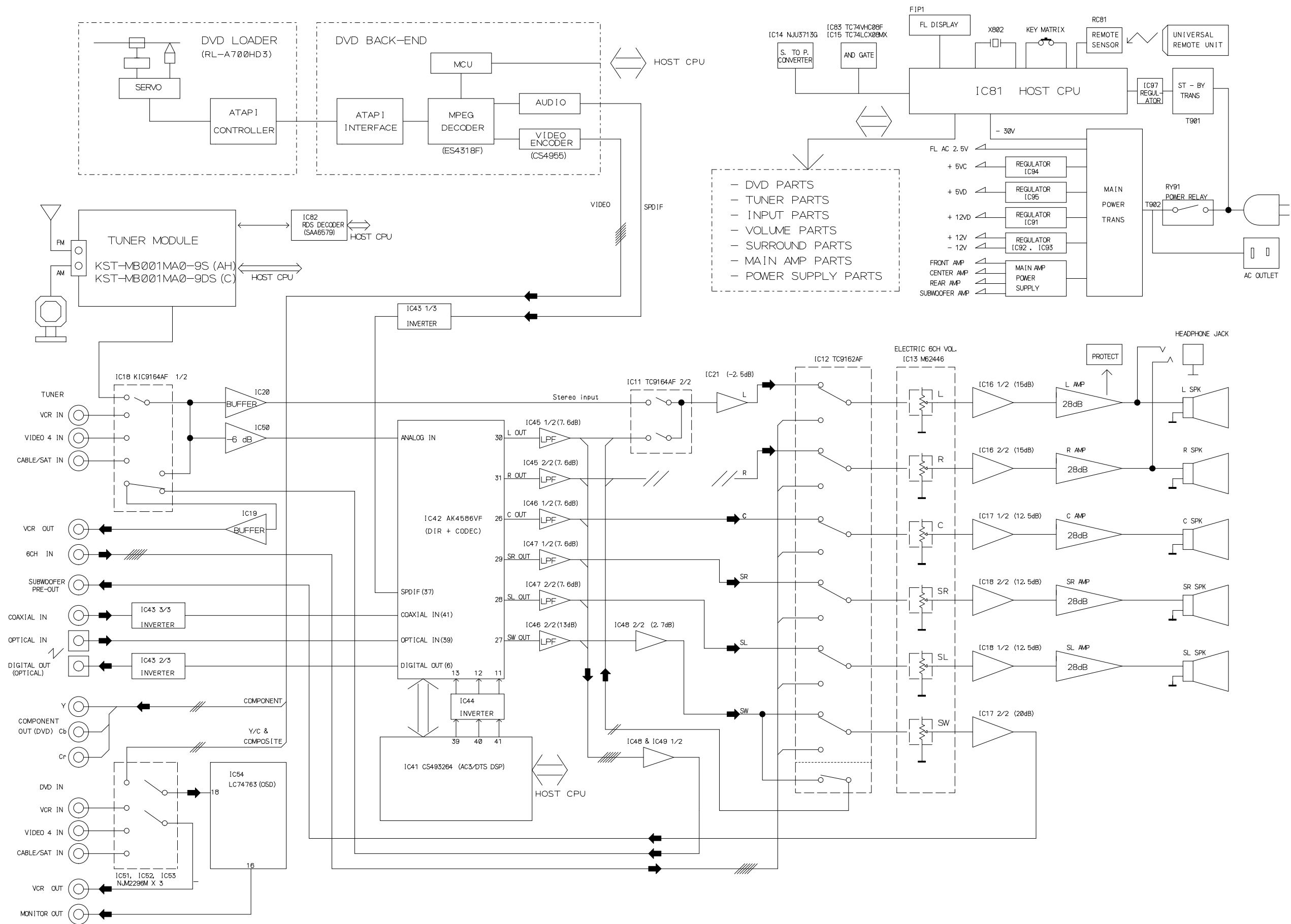

2. WIRING DIAGRAM

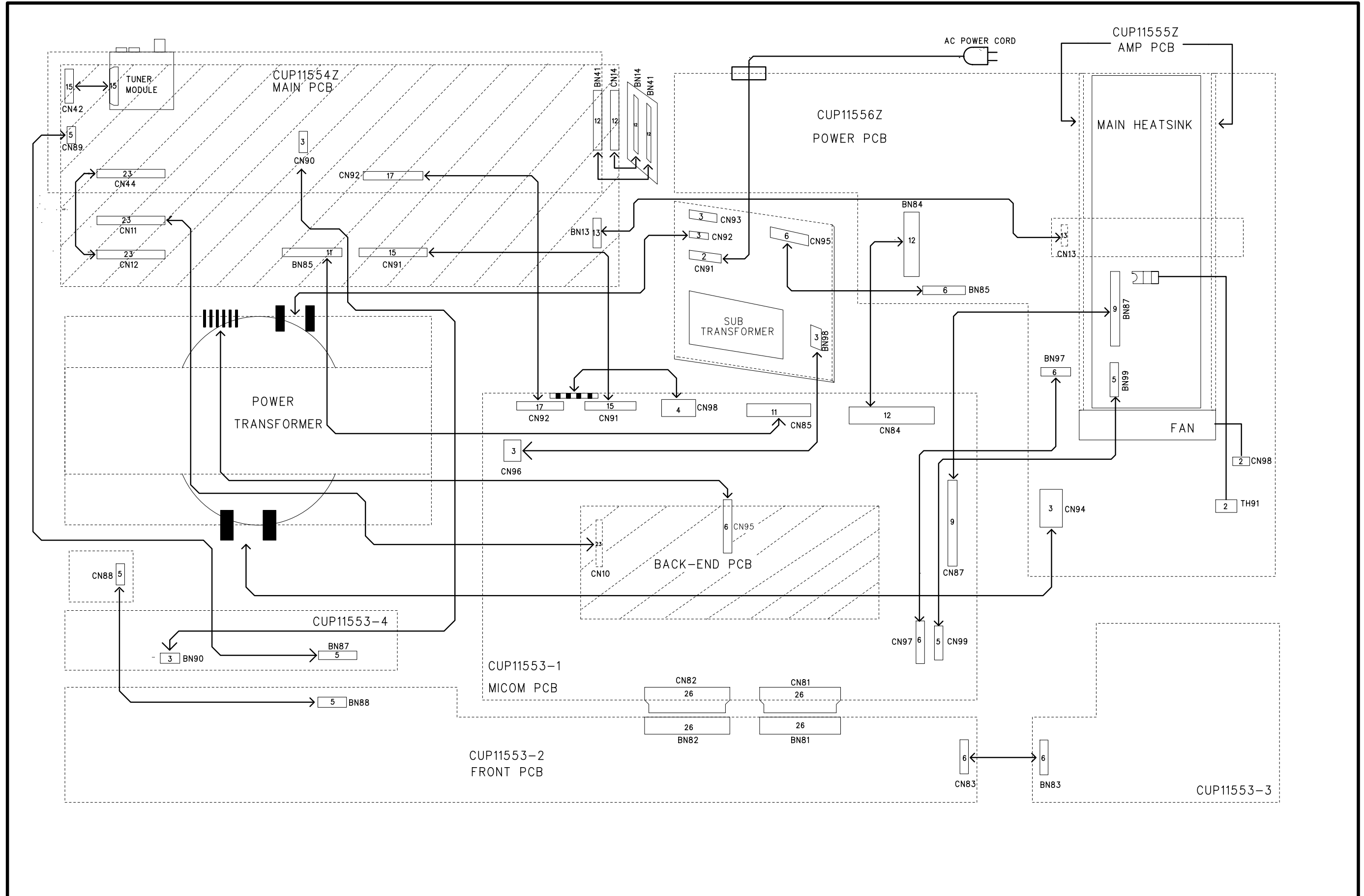

3. SCHEMATIC DIAGRAM FRONT & μ-COM PART

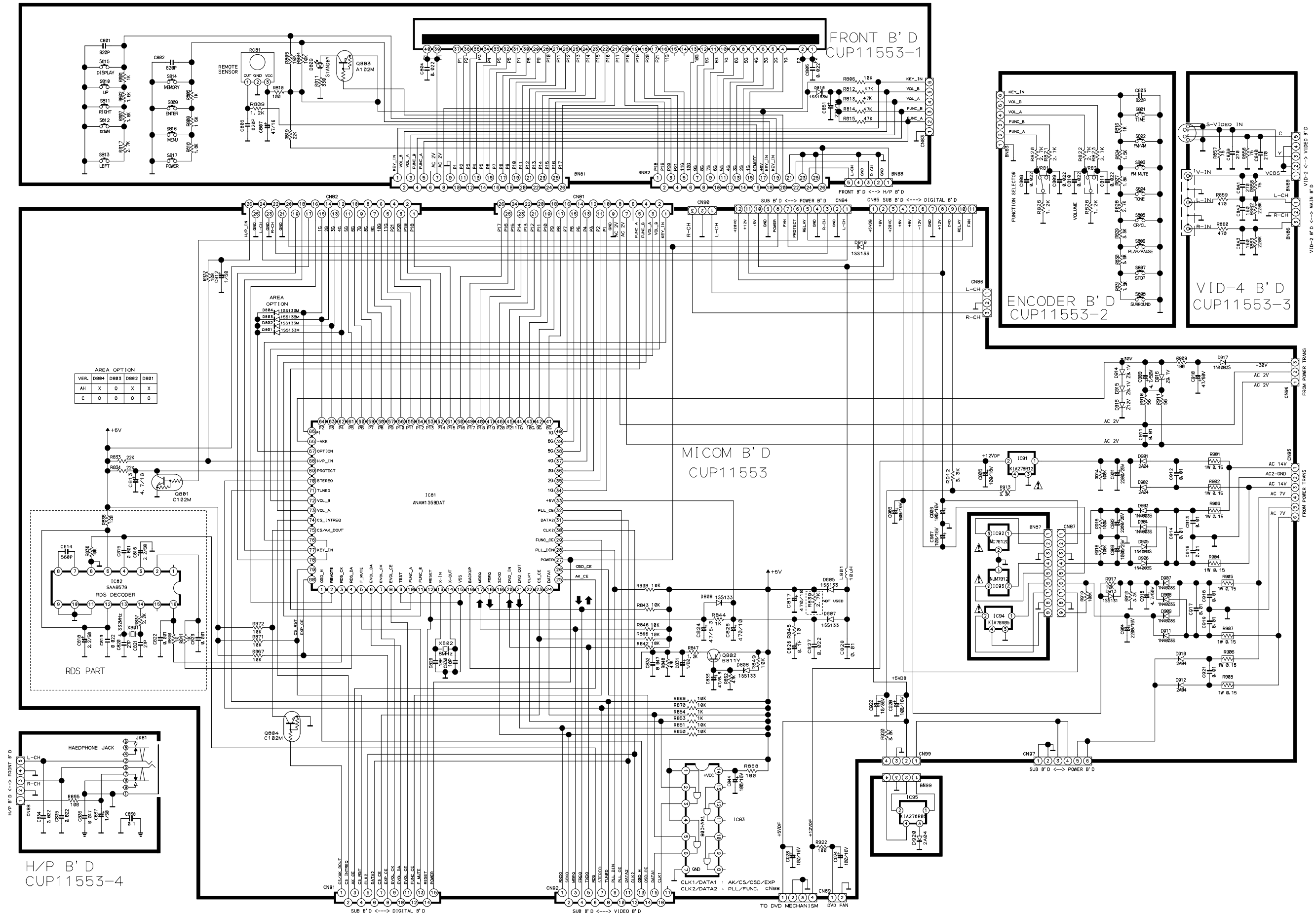

AREA OPTION

VER.	DB84	DB85	DB82	DB81
AH	X	O	X	X
C	O	O	O	O

INPUT & VOLUME PART

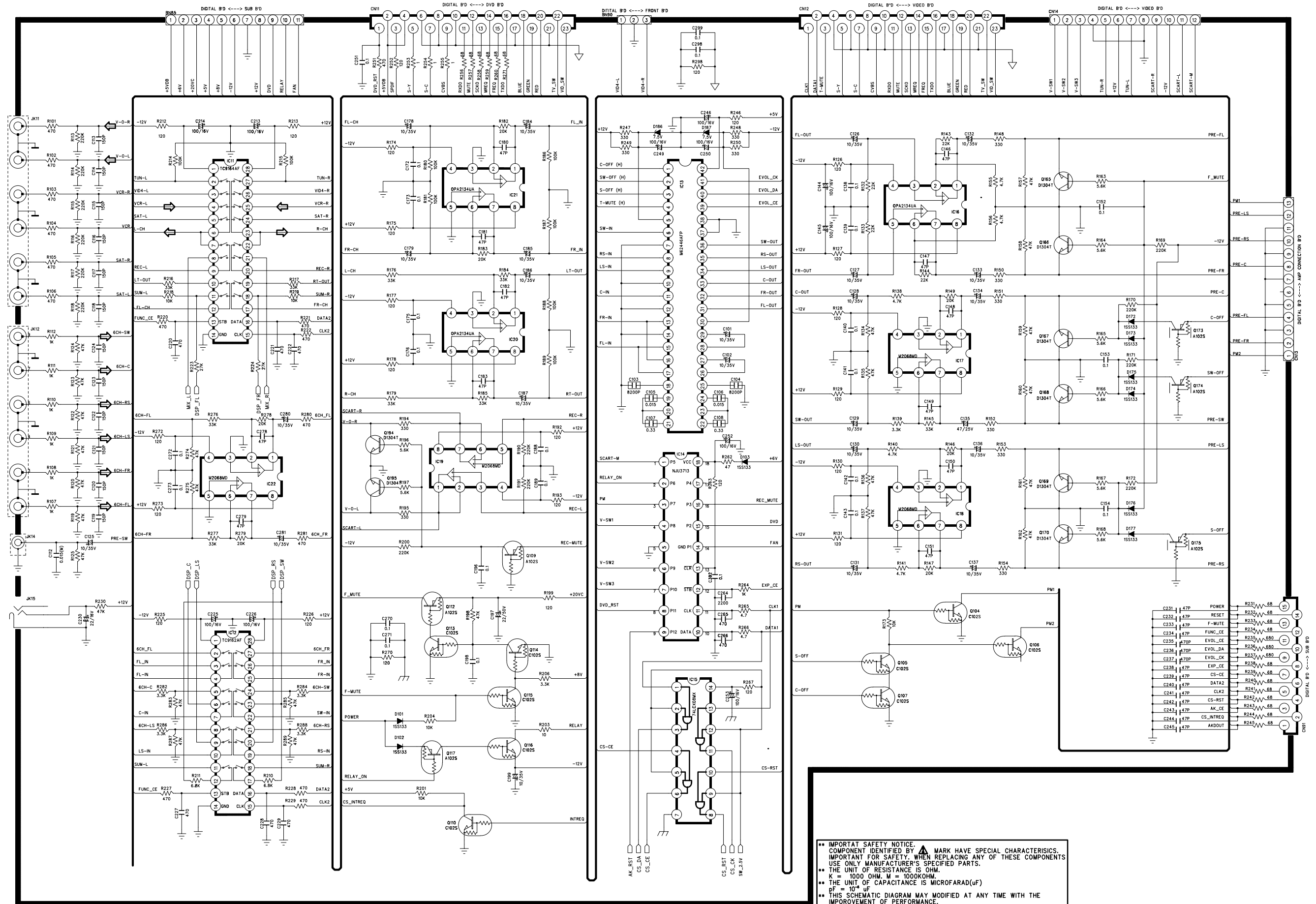

DSP & CODEC PART

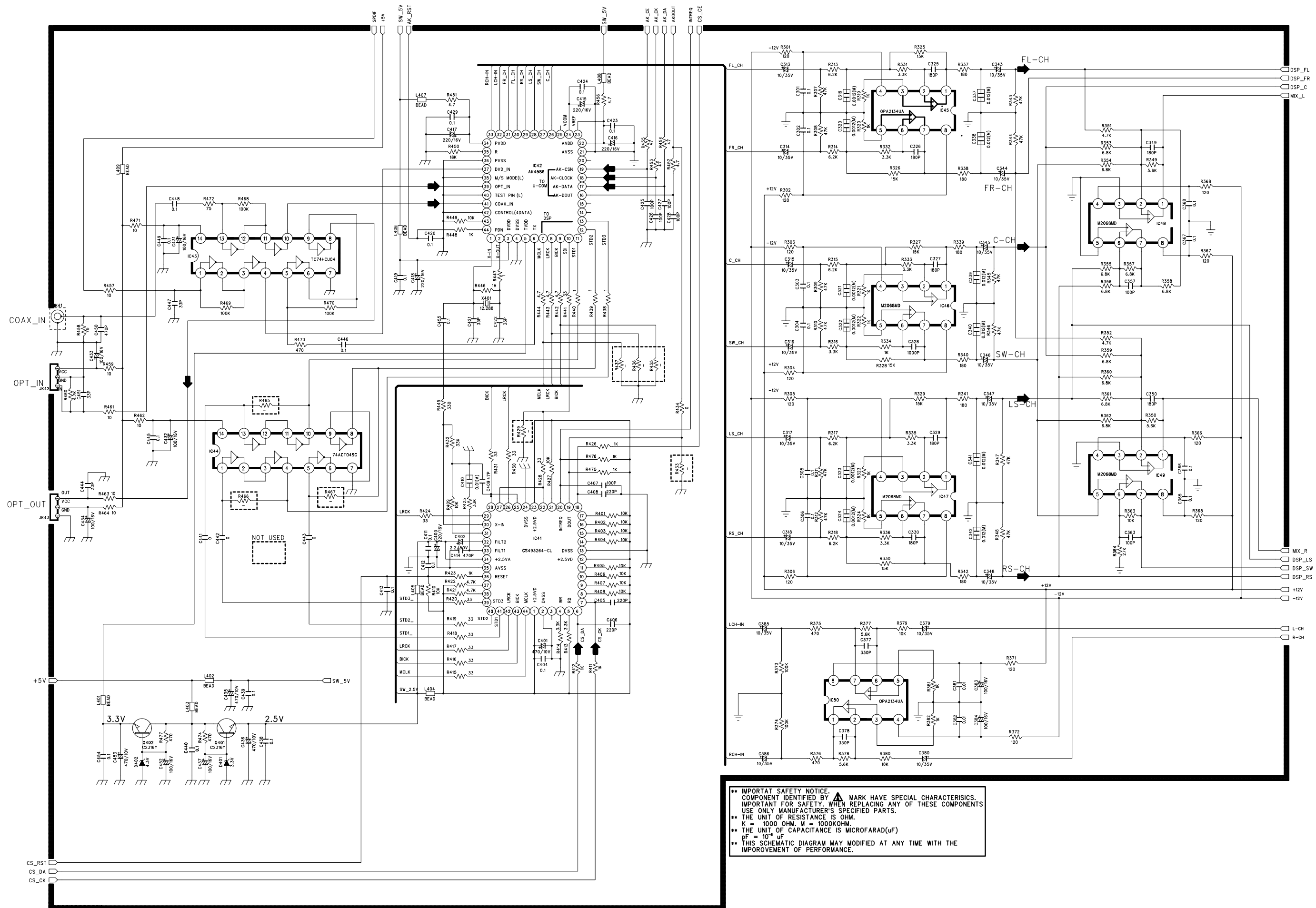

**** IMPORTANT SAFETY NOTICE.**
COMPONENT IDENTIFIED BY MARK HAVE SPECIAL CHARACTERISTICS.
IMPORTANT FOR SAFETY. WHEN REPLACING ANY OF THESE COMPONENTS
USE ONLY MANUFACTURER'S SPECIFIED PARTS.
**** THE UNIT OF RESISTANCE IS OHM.**
K = 1000 OHM, M = 1000KOHM.
**** THE UNIT OF CAPACITANCE IS MICROFARAD (uF)**
pF = 10⁻¹² uF
**** THIS SCHEMATIC DIAGRAM MAY MODIFIED AT ANY TIME WITH THE**
IMPROVEMENT OF PERFORMANCE.

VIDEO PART

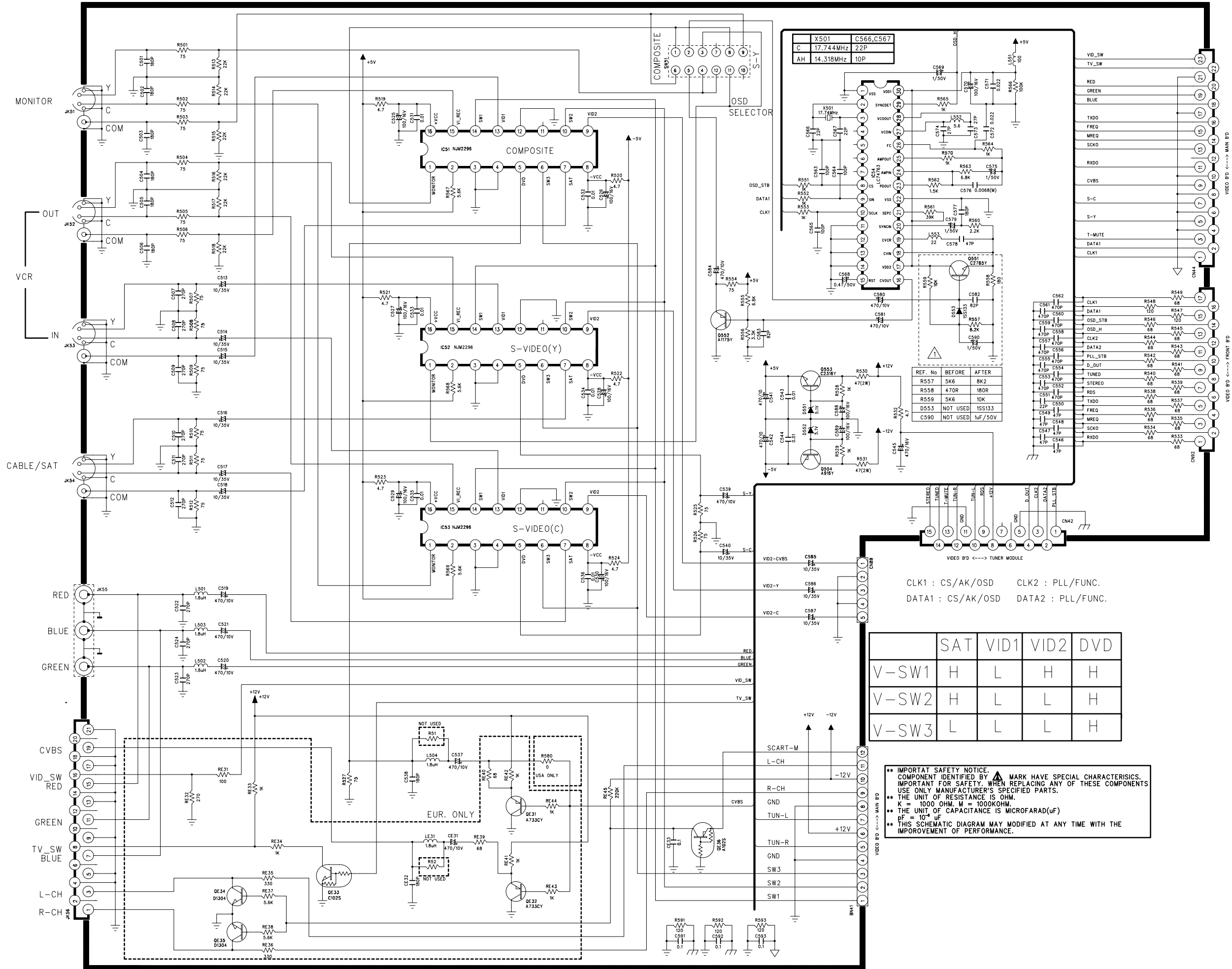

AMP. PART

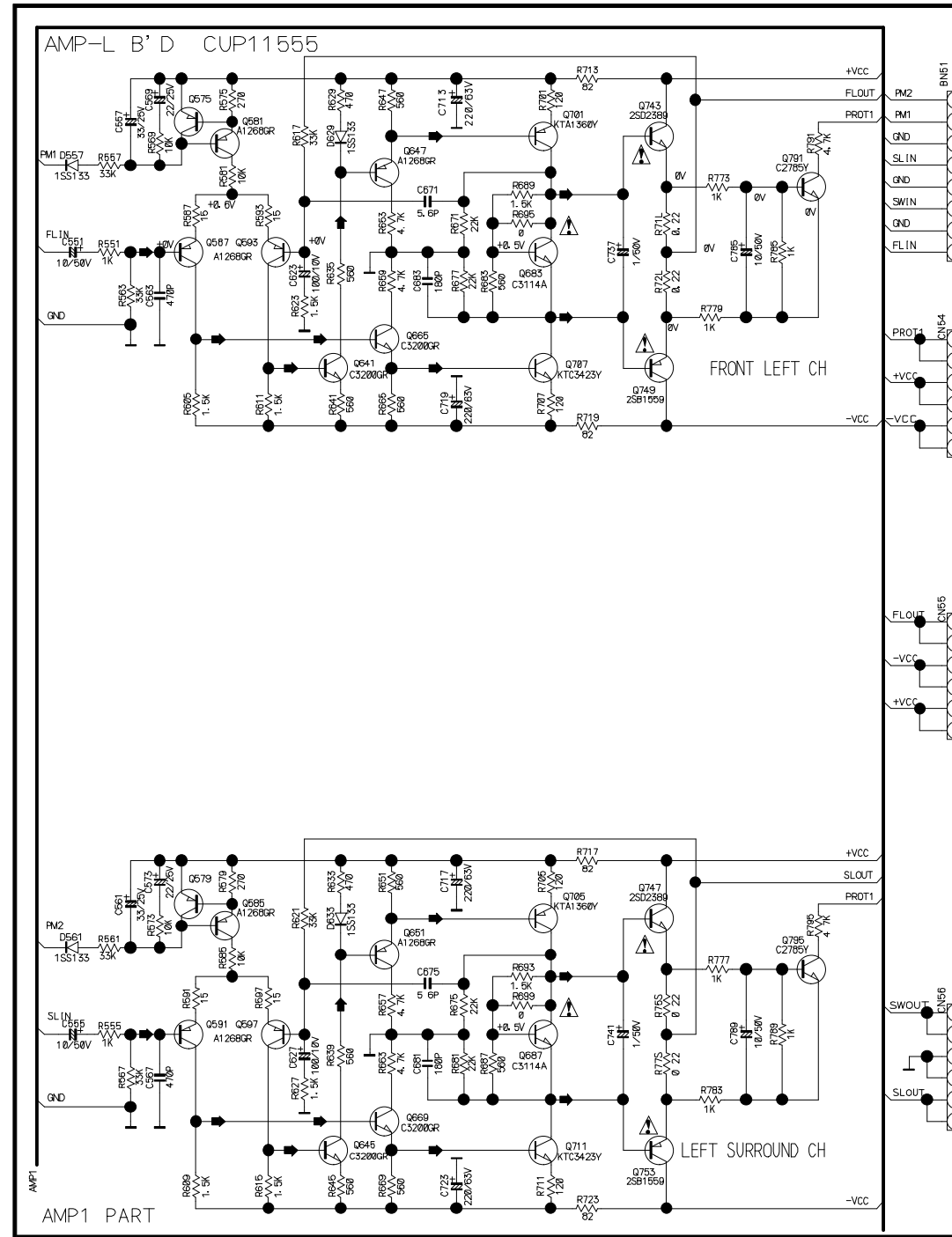

5CH AMPLIFIER PART

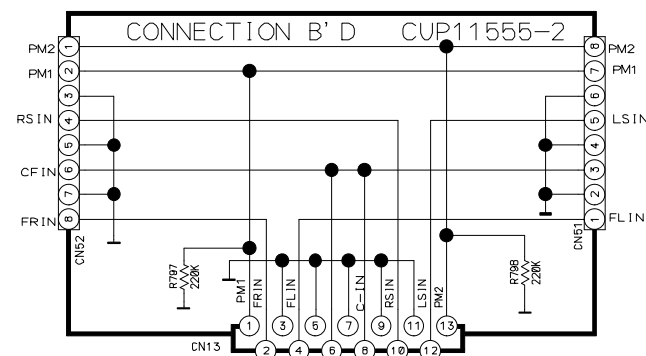
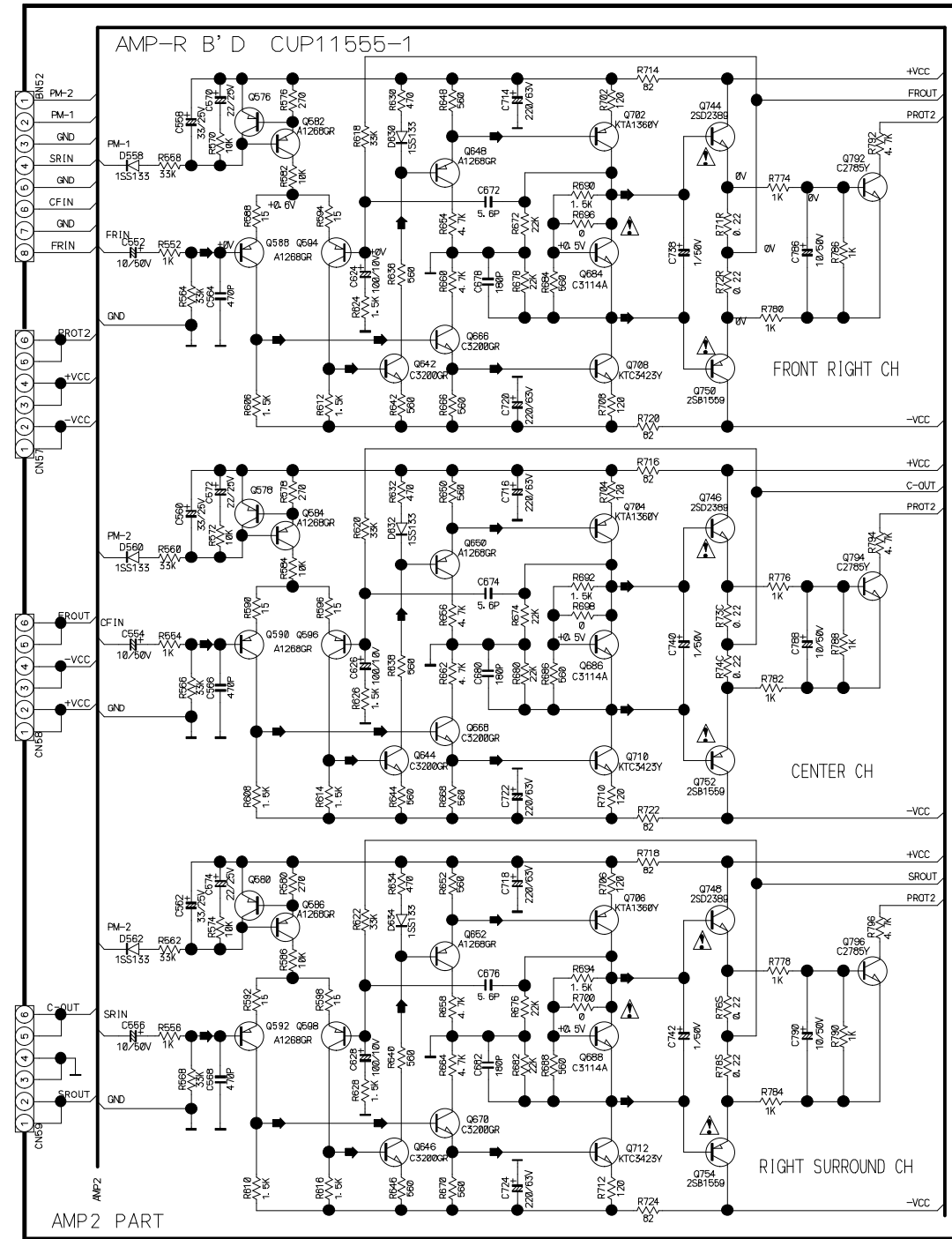

**** IMPORTANT SAFETY NOTICE.**
 COMPONENTS IDENTIFIED BY  MARK HAVE SPECIAL CHARACTERISTICS.
 IMPORTANT FOR SAFETY WHEN REPLACING ANY OF THESE COMPONENTS
 USE ONLY MANUFACTURER'S SPECIFIED PARTS.
 ** THE UNIT OF RESISTANCE IS OHM
 K=1000 OHM, M=1000 KOHM.
 ** THE UNIT OF CAPACITANCE IS MICROFARAD (uF)
 pF=10⁻⁶ uF
 ** THIS SCHEMATIC DIAGRAM MAY MODIFIED AT ANY TIME WITH THE
 IMPROVEMENT OF PERFORMANCE.
 ** ALL VOLTAGE ARE MEASURED WITH GROUND.
 DC-VALUES WITH NO SIGNAL AC-RMS

POWER PART

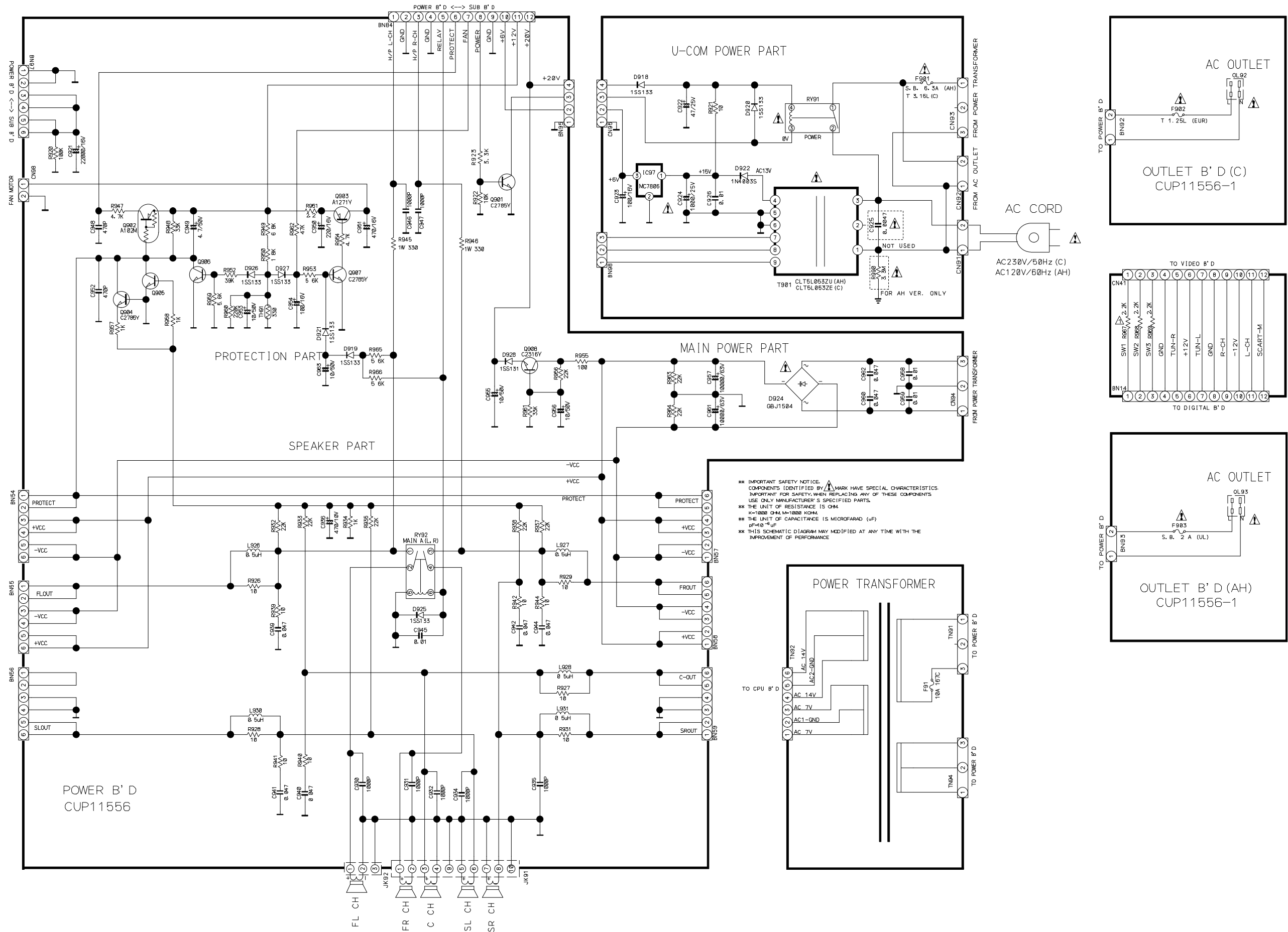

DVD BACK_END PART

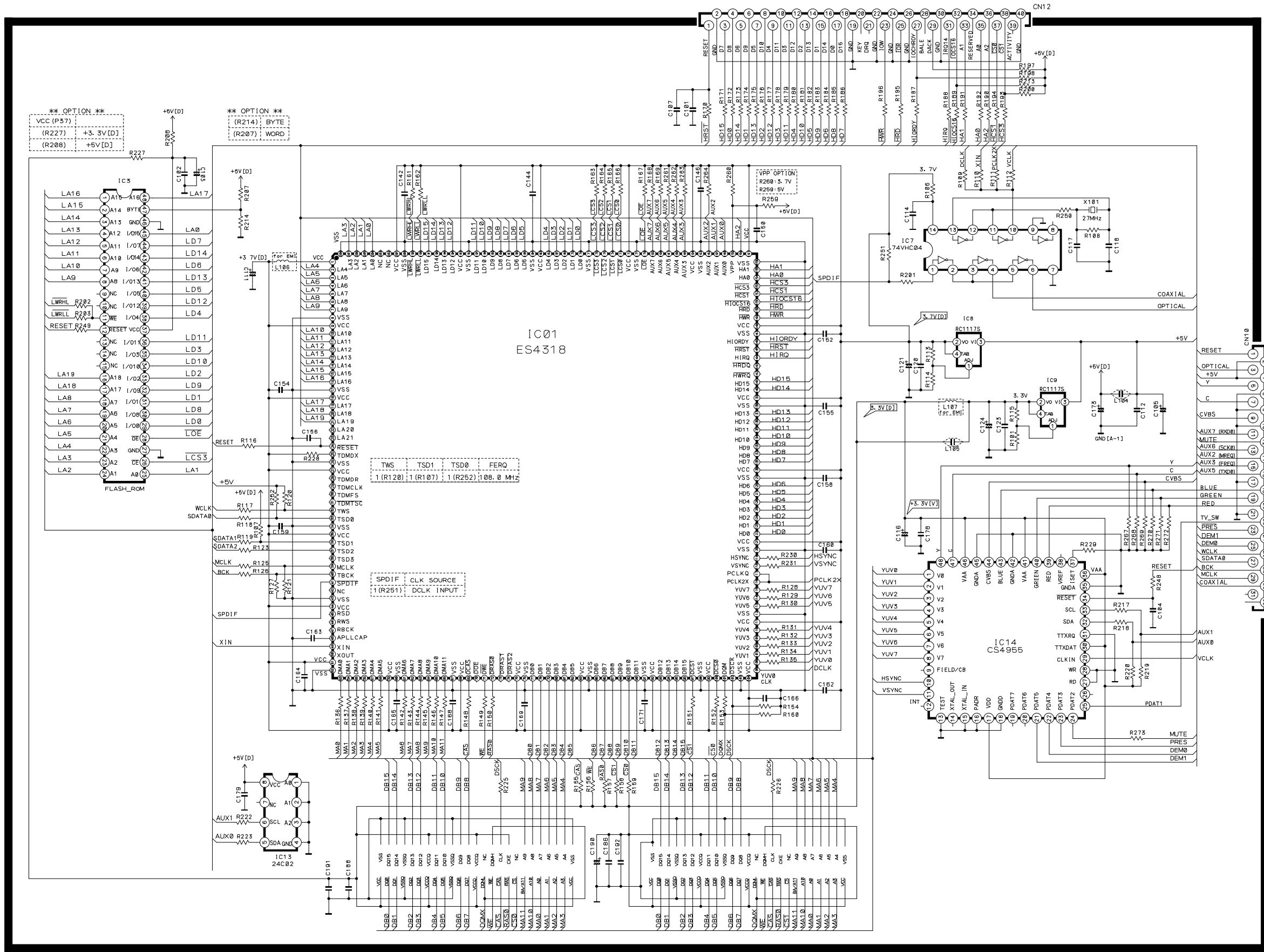

R101	360	R171	33	R241	NS	C141	NS
R102	NS	R172	33	R242	NS	C142	0.1
R103	NS	R173	33	R243	NS	C143	NS
R104	NS	R174	33	R244	NS	C144	0.1
R105	NS	R175	33	R245	NS	C145	NS
R106	0	R176	33	R246	NS	C146	0.1
R107	4.7K	R177	33	R247	NS	C147	NS
R108	1M	R178	33	R248	1K	C148	NS
R109	120	R179	33	R249	1K	C149	NS
R110	120	R180	33	R250	330	C150	0.1
R111	120	R181	33	R251	4.7K	C151	NS
R112	120	R182	33	R252	4.7K	C152	0.1
R113	220	R183	33	R253	NS	C153	NS
R114	430	R184	33	R254	NS	C154	0.1
R115	220	R185	33	R255	NS	C155	0.1
R116	1K	R186	33	R256	NS	C156	0.1
R117	10	R187	47	R257	NS	C157	NS
R118	10	R188	47	R258	NS	C158	0.1
R119	10	R189	47	R259	NC	C159	0.1
R120	4.7K	R190	33	R260	0	C160	0.1
R121	47K	R191	33	R261	47K	C161	NS
R122	NS	R192	33	R262	47K	C162	0.1
R123	10	R193	47	R263	47K	C163	150p
R124	NS	R194	47	R264	4.7K	C164	0.1
R125	10	R195	47	R265	NS	C165	0.1
R126	10	R196	47	R266	82	C166	0.1
R127	47K	R197	4.7K	R267	75	C167	NS
R128	33	R198	4.7K	R268	75	C168	0.01
R129	33	R199	NS	R269	75	C169	0.1
R130	33	R200	4.7K	R270	1K	C170	NS
R131	33	R201	33	R271	NS	C171	0.1
R132	33	R202	NC	R272	75	C172	NS
R133	33	R203	10	R273	100/6.3	C173	100/6.3
R134	33	R204	NS	R274	100/6.3	C174	NS
R135	33	R205	NS	R275	100/6.3	C175	NS
R136	10	R206	NS	R276	NS	C176	NS
R137	10	R207	NC	R277	NS	C177	NS
R138	10	R208	0	R278	NS	C178	0.1
R139	10	R209	NS	R279	NS	C179	0.1
R140	10	R210	NS	R280	NS	C180	NS
R141	10	R211	NS	R281	NS	C181	NS
R142	10	R212	NS	R282	NS	C182	NS
R143	10	R213	4.7K	R283	NS	C183	NS
R144	10	R214	0	R284	NS	C184	NS
R145	10	R215	NS	R285	NS	C185	NS
R146	10	R216	NS	R286	NS	C186	0.1
R147	10	R217	100	R287	NS	C187	NS
R148	33	R218	100	R288	NS	C188	0.1
R149	33	R219	1.5K	R289	NS	C189	NS
R150	33	R220	1.5K	R290	NS	C190	47/6.3
R151	33	R221	NS	R291	NS	C191	0.1
R152	33	R222	100	R292	NS	C192	0.1
R153	33	R223	100	R293	NS	C193	NS
R154	47K	R224	NS	R294	NS	C194	NS
R155	47K	R225	10	R295	NS	C195	NS
R156	47K	R226	10	R296	NS	C196	0
R157	47K	R227	NC	R297	NS	C197	0
R158	47K	R228	4.7K	R298	NS	C198	NS
R159	47K	R229	4K	R299	NS	C199	NS
R160	47K	R230	33	R300	NS	C200	NS
R161	NC	R231	33	R301	NS	C201	NS
R162	47K	R232	NS	R302	NS	C202	NS
R163	47K	R233	NS	R303	NS	C203	NS
R164	47K	R234	NS	R304	NS	C204	NS
R165	47K	R235	NS	R305	NS	C205	NS
R166	47K	R236	NS	R306	NS	C206	NS
R167	47K	R237	NS	R307	NS	C207	NS
R168	47K	R238	NS	R308	NS	C208	NS
R169	47K	R239	NS	R309	NS	C209	NS
R170	47	R240	NS	R310	NS	C210	NS

SECTION 3

ELECTRICAL PARTS LIST

■ RESISTORS AND CAPACITORS

Notes : • Part numbers are indicated for most mechanical parts.

Please use this part number for parts order.

• **IMPORTANT SAFETY NOTICE.**

Components identified by Δ mark have special characteristics important for safety.

When replacing any of these components, use only manufacture's specified parts.

• The unit of resistance is OHM (Ω)

K=1000 (Ω), M=1000 (K Ω)

• The unit of capacitance is MICROFARAD (μ F)

P=10⁻⁶ μ F

■ Numbering System of Resistor

Example

CRD 25 F J 101
Type Wattage Shape Tolerance Value

Resistor Type	Wattage	Tolerance
K(C)RD: Carbon	20:1/5W	F:= \pm 1%
K(C)RG: Metal Oxide	25:1/4W 50:1/2W 1:1W	J:= \pm 5% K:= \pm 10%
K(C)RG: Metal Cement	2:2W 3:3W	
K(H)RJ: Carbon. CHIP	10:1/10W 14:1/4W	

■ Numbering System of Capacitor

Example

HCKR 1H 101 K B
Type Voltage Value Tolerance Peculiarity

Capacitor Type	Voltage		Tolerance
	HCEA Type	Other	
HCB: Ceramic	0J:6.3V	1H:50V DC	C: \pm 0.25pF
CCC: Ceramic	1A:10V	1:125V DC	G: \pm 2%
CCK: Ceramic	1C:16V	KC:400V AC	J: \pm 5%
HCQI: Polyester	1E:25V		K: \pm 10%
HCQP: Polypropylene	1H:50V		Z: +80%, -20%
HCQS: Polystyrol	1V:35V		
HCUS: Ceramic			
HCEA: ELECT			
HCEA: ELECT. CHIP			

LOAD NO.	PART NO.	DESCRIPTION	SPECIFICATION
	CUP11553-1	MICOM PCB	
BN87	CWB1D909130BM	WIRE ASS'Y	
BN99	CWB1E904170BM	WIRE ASS'Y	
C813	HCEA1HH4R7T	CAPACITOR , ELECT	4.7uF 50V
C814	CCKT1H561KB	CAPACITOR , CERAMIC	560pF 50V KB
C815	CCKT1H102KB	CAPACITOR , CERAMIC	1000pF 50V KB
C816, C818	HCEA1HH2R2T	CAPACITOR , ELECT	2.2uF 50V
C817	HCEA1AH471T	CAPACITOR , ELECT	470uF 10V
C819	CCKT1H223ZF	CAPACITOR , CERAMIC	0.022uF 50V ZF
C820, C821	CCCT1H270JC	CAPACITOR , CERAMIC	22pF 50V JC
C822, C823	CCKT1H102KB	CAPACITOR , CERAMIC	1000pF 50V KB
C824	HCEA1AH470T	CAPACITOR , ELECT	47uF 10V
C825	HCEA1AH471T	CAPACITOR , ELECT	470uF 10V
C826	BCES0HD104	CAPACITOR , GOLD	EECS0HD104V
C827	CCKT1H223ZF	CAPACITOR , CERAMIC	0.022uF 50V ZF
C828	CCKT1H103ZF	CAPACITOR , CERAMIC	0.01uF 50V ZF
C829, C830	CCCT1H180JC	CAPACITOR , CERAMIC	18pF 50V JC
C831	HCEA1HH1R0T	CAPACITOR , ELECT	1uF 50V
C832	CCKT1H473ZF	CAPACITOR , CERAMIC	0.047uF 50V ZF
C833	HCEA1AH470T	CAPACITOR , ELECT	47uF 10V
C844	HCEA1CH470T	CAPACITOR , ELECT	47uF 16V
C851	HCEA1CH221T	CAPACITOR , ELECT	220uF 16V
C901~C903	CCEA1EKR222E	CAPACITOR , ELECT	2200uF/25V
C904	CCEA1CKR222E	CAPACITOR , ELECT	2200uF/16V

LOAD NO.	PART NO.	DESCRIPTION	SPECIFICATION
C905~C908	HCEA1CH101T	CAPACITOR , ELECT	100uF 16V
C909	HCEA1HH4R7T	CAPACITOR , ELECT	4.7uF 50V
C910	HCEA1HH470T	CAPACITOR , ELECT	47uF 50V
C911~C915	CCKT1H103ZF	CAPACITOR , CERAMIC	0.01uF 50V ZF
C916	HCEA1HH4R7T	CAPACITOR , ELECT	4.7uF 50V
C917~C919	CCKT1H103ZF	CAPACITOR , CERAMIC	0.01uF 50V ZF
C920	HCEA1CH101T	CAPACITOR , ELECT	100uF 16V
C921	CCKT1H103ZF	CAPACITOR , CERAMIC	0.01uF 50V ZF
C922	HCEA1VH100T	CAPACITOR , ELECT	10uF 35V
C923, C924	HCEA1CH101T	CAPACITOR , ELECT	100uF 16V
CN81, CN82	BJP26GA133ZK	FLEXIBLE CONNECTOR(PLUG)	TMC-D26P-A1
CN84	KJP12GA19ZM	WAFER	
CN85	KJP11GA19ZM	WAFER	MOLEX-53014
CN86	KJP03GA19ZM	WAFER	
CN87	KJP09GA01ZM	WAFER	MOLEX5267-09A
CN89	KJP02GA01ZM	WAFER	MOLEX 5267-02A
CN90	KJP03GA19ZM	WAFER	
CN91	KJP15GA117ZG	CARD CABLE , WAFER	15P 1M/M S/T
CN92	KJP17GA117ZG	WAFER , CARD CABLE	GF102-17S-TS
CN95	KJP06GA01ZM	WAFER	MOLEX 5267-06A
CN96	KJP03GA01ZM	WAFER	MOLEX 5267-03A
CN97	KJP06GA19ZM	WAFER	MOLEX53014-0610
CN98, CN99	KJP04GA01ZM	WAFER	MOLEX 5267-04A
D801	HVD1SS133MT	DIODE (C VER.)	1SS133T-77
D802	HVD1SS133MT	DIODE (C VER.)	1SS133T-77
D803	HVD1SS133MT	DIODE	1SS133T-77
D804	HVD1SS133MT	DIODE (C VER.)	1SS133T-77
D805~D808	HVD1SS133MT	DIODE	1SS133T-77
D810	HVD1SS133MT	DIODE	1SS133T-77
D901, D902	HVD2A04H	RECT. , DIODE(2A)	
D903~D909	KVD1N4003ST	DIODE	1N4003
D910, D912	HVD2A04H	RECT. , DIODE(2A)	
D911	KVD1N4003ST	DIODE	1N4003
D913	HVD1SS133MT	DIODE	1SS133T-77
D914~D906	HVDMTZJ9.1BT	DIODE , ZENER	9.1V 1/2W
D917	KVD1N4003ST	DIODE	1N4003
D918	HVDMTZJ12BT	DIODE , ZENER	12V 1/2W
D919	HVD1SS133MT	DIODE	1SS133T-77
D920	HVD2A04H	RECT. , DIODE(2A)	
IC81	HVIANAM1359DAT	I.C , MICOM	
IC82	BVISAA6579TV1	I.C , RDS FILTER	SAA6579T/V1
IC83	HVITC74VHC08F	I.C , QUAD AND GATE (2 IN)	TC74VHC08F
IC91	HVIKIA278R12PI	12V REGULATOR	KIA278R12PI
IC92	HVIMC7812C	12V REGULATOR	KA7812-ABTU
IC93	HVINJM7912FA	-12V REGULATOR	
IC94	HVIKIA78R05PI	5V REGULATOR	KIA78R05PI
IC95	HVIKIA278R06PI	6V REGULATOR	KIA278R06
JW81, JW82	CWE8202110RV	WIRE, ASS'Y	
JW83	CWE8202150RV	WIRE ASS'Y	
L801	HLQ02C100KT	COIL , AXAIL	10uH
Q801	HVTKRC102MT	TRANSISTOR	KRC102M
Q802	HVTKSB811YT	TRANSISTOR	
Q804	HVTKRC102MT	TRANSISTOR	KRC102M
R832	CRD20TJ101T	RESISTOR , CARBON	100 OHM 1/5W J
R833, R834	CRD20TJ223T	RESISTOR , CARBON	22K OHM 1/5W J

LOAD NO.	PART NO.	DESCRIPTION	SPECIFICATION
R835	CRD20TJ101T	RESISTOR , CARBON	100 OHM 1/5W J
R836	CRD20TJ103T	RESISTOR , CARBON	10K OHM 1/5W J
R837	CRD20TJ222T	RESISTOR , CARBON	2.2K OHM 1/5W J
R838	CRD20TJ103T	RESISTOR , CARBON	10K OHM 1/5W J
R840, R841	CRD20TJ102T	RESISTOR , CARBON	1K OHM 1/5W J
R842, R843	CRD20TJ103T	RESISTOR , CARBON	10K OHM 1/5W J
R844	CRD20TJ102T	RESISTOR , CARBON	1K OHM 1/5W J
R845	CRD20TJ100T	RESISTOR , CARBON	10 OHM 1/5W J
R846	CRD20TJ103T	RESISTOR , CARBON	10K OHM 1/5W J
R847	CRD20TJ122T	RESISTOR , CARBON	1.2K OHM 1/5W J
R848	CRD20TJ473T	RESISTOR , CARBON	47K OHM 1/5W J
R849~R851	CRD20TJ103T	RESISTOR , CARBON	10K OHM 1/5W J
R852	CRD20TJ473T	RESISTOR , CARBON	47K OHM 1/5W J
R853, R854	CRD20TJ102T	RESISTOR , CARBON	1K OHM 1/5W J
R866	CRD20TJ103T	RESISTOR , CARBON	10K OHM 1/5W J
R867	CRD20TJ103T	RESISTOR , CARBON	10K OHM 1/5W J
R868	CRD20TJ101T	RESISTOR , CARBON	100 OHM 1/5W J
R869~R872	CRD20TJ103T	RESISTOR , CARBON	10K OHM 1/5W J
R901~R908	KRQ1AJR15H	RESISTOR , FUSIBLE	0.15 OHM , 1W J
R909	CRD20TJ181T	RESISTOR , CARBON	180 OHM 1/5W J
R910, R911	CRD25TJ560T	RESISTOR , CARBON	56 OHM 1/4W J
R912, R913	CRD20TJ332T	RESISTOR , CARBON	3.3K OHM 1/5W J
R914~R916	CRD20TJ104T	RESISTOR , CARBON	100K OHM 1/5W J
R917	CRD20TJ102T	RESISTOR , CARBON	1K OHM 1/5W J
R918	CRD20TJ332T	RESISTOR , CARBON	3.3K OHM 1/5W J
R919	CRD20TJ104T	RESISTOR , CARBON	100K OHM 1/5W J
R920	CRD20TJ332T	RESISTOR , CARBON	3.3K OHM 1/5W J
R922	CRD25TJ101T	RESISTOR , CARBON	100 OHM 1/4W J
X801	HOX04332A200C	CRYSTAL	4.332MHz
X802	HOX08000E160C	CRYSTAL	8MHz
	HLZ9Z009Z	FERRITE CORE	LF-50BR
	CUP11553-2	FRONT PCB	
BN81	BJP26GB132ZK	FLEXIBLE CONNECTOR(SOCKET)	TMC-D26X-A1
BN82	BJP26GB132ZK	FLEXIBLE CONNECTOR(SOCKET)	TMC-D26X-A1
BN88	CWB1C905100EN	WIRE ASS'Y	
C801, C802	HCBS1H821KBT	CAPACITOR , CERAMIC	820pF 50V K
C804, C805	HCBS1H223ZFT	CAPACITOR , CERAMIC	0.022uF 50V Z
C806	HCBS1H821KBT	CAPACITOR , CERAMIC	820pF 50V K
C807	HCEA1CKS470T	CAPACITOR, ELECT	
CN83	KJP06GA19ZM	WAFER	MOLEX53014-0610
D809	BVDSEL2E10CFT	L.E.D , BLUE	
FIP1	KFLHNA11SM28	F.I.P	HNA-11SM28
Q803	HVTKRA102MT	TRANSISTOR	KRA102M
R801	CRD20TJ102T	RESISTOR , CARBON	1K OHM 1/5W J
R802	CRD20TJ152T	RESISTOR , CARBON	1.5K OHM 1/5W J
R803	CRD20TJ102T	RESISTOR , CARBON	1K OHM 1/5W J
R804~R806	CRD20TJ103T	RESISTOR , CARBON	10K OHM 1/5W J
R807	CRD20TJ182T	RESISTOR , CARBON	1.8K OHM 1/5W J
R808	CRD20TJ152T	RESISTOR , CARBON	1.5K OHM 1/5W J
R809	CRD20TJ122T	RESISTOR , CARBON	1.2K OHM 1/5W J
R810	CRD20TJ101T	RESISTOR , CARBON	100 OHM 1/5W J
R811	CRD20TJ331T	RESISTOR , CARBON	330 OHM 1/5W J
R812~R815	CRD20TJ473T	RESISTOR , CARBON	47K OHM 1/5W J
R817	CRD20TJ272T	RESISTOR , CARBON	2.7K OHM 1/5W J

LOAD NO.	PART NO.	DESCRIPTION	SPECIFICATION
R818	CRD20TJ182T	RESISTOR , CARBON	1.8K OHM 1/5W J
R819	CRD20TJ223T	RESISTOR , CARBON	22K OHM 1/5W J
RC81	HRVKSM603TH2	REMOTE SENSER	KSM-603TH2
S809	HST1A019ZT	SW , TACT	
S810~S817	CST1A012ZT	SW , TACT	SKHV10910G
	CUP11553-3	ENCODER PCB	
BN83	CWB1C906050EN	WIRE ASS'Y	
C803	HCBS1H821KBT	CAPACITOR , CERAMIC	820pF 50V K
C808~C811	HCBS1H223ZFT	CAPACITOR , CERAMIC	0.022uF 50V Z
R816	CRD20TJ102T	RESISTOR , CARBON	1K OHM 1/5W J
R820~R823	CRD20TJ272T	RESISTOR , CARBON	2.7K OHM 1/5W J
R824	CRD20TJ152T	RESISTOR , CARBON	1.5K OHM 1/5W J
R825, R826	CRD20TJ272T	RESISTOR , CARBON	2.7K OHM 1/5W J
R827	CRD20TJ182T	RESISTOR , CARBON	1.8K OHM 1/5W J
R828	CRD20TJ272T	RESISTOR , CARBON	2.7K OHM 1/5W J
R829	CRD20TJ332T	RESISTOR , CARBON	3.3K OHM 1/5W J
R830	CRD20TJ562T	RESISTOR , CARBON	5.6K OHM 1/5W J
R831	CRD20TJ752T	RESISTOR , CARBON	7.5K OHM 1/5W J
S801~S808	CST1A012ZT	SW , TACT	SKHV10910G
VR81	HSR2A015Z	ENCODER	EC16B12S00B2ZZZ
VR82	HSR2A018Z	VR , ENCODER	EC16B24T03B2ZZZ
	CUP11553-4	JACK PCB	
BN86	CWZL70BN86	WIRE ASS'Y	3P , 100MM
BN89	CWB1C905350EN	WIRE ASS'Y	
C839~C841	CCKT1H271KB	CAPACITOR , CERAMIC	270pF 50V KB
C842, C843	CCKT1H151KB	CAPACITOR , CERAMIC	150pF 50V KB
JK82	CJJ9M003Y	JACK , S-VIDEO(GOLD)	
JK83	KJJ4S027Z	JACK BOARD(3P) WITH SWITCH	
R856~R858	CRD20TJ750T	RESISTOR , CARBON	75 OHM 1/5W J
R859, R860	CRD20TJ471T	RESISTOR , CARBON	470 OHM 1/5W J
R862, R863	CRD20TJ224T	RESISTOR , CARBON	220K OHM 1/5W J
	CUP11553-5	HEADPHONE PCB	
C834, C835	CCKT1H223ZF	CAPACITOR , CERAMIC	0.022uF 50V ZF
C836	CCKT1H473ZF	CAPACITOR , CERAMIC	0.047uF 50V ZF
C837	HCEA1HH1R0T	CAPACITOR , ELECT	1uF 50V
C838	CCKT1H104ZF	CAPACITOR , CERAMIC	0.1uF 50V
CN88	KJP05GA19ZM	WAFER	MOLEX53014-0510
JK81	HJJ2E020Z	JACK , HEADPHONE	HTJ-064-05NG
R855	CRD20TJ101T	RESISTOR , CARBON	100 OHM 1/5W J
	CUP11554-1	MAIN PCB	
C101, C102	HCEA1VH100T	CAPACITOR , ELECT	10uF 35V
C103, C104	HCQI1H822JZT	CAPACITOR , MYLAR	8200pF 50V J
C105, C106	HCQI1H153JZT	CAPACITOR , MYLAR	0.015uF 50V J
C107, C108	KCFE1J334JBT	CAPACITOR , FILM	0.33uF 63V J
C112	HCQI1H153JZT	CAPACITOR , MYLAR	0.015uF 50V J
C113~C124	HCUS1H151JA	CAPACITOR , CHIP	150pF
C125~C134	HCEA1VH100T	CAPACITOR , ELECT	10uF 35V
C135	HCEA1EH470T	CAPACITOR , ELECT	47uF 25V
C136, C137	HCEA1VH100T	CAPACITOR , ELECT	10uF 35V
C138~C143	HCUS1E104ZF	CAPACITOR , CHIP	0.1uF 25V
C144, C145	HCEA1CH101T	CAPACITOR , ELECT	100uF 16V

LOAD NO.	PART NO.	DESCRIPTION	SPECIFICATION
C146~C151	HCUS1H470JA	CAPACITOR , CHIP	47pF
C152~C154	HCUS1E104ZF	CAPACITOR , CHIP	0.1uF 25V
C172, C173	HCUS1E104ZF	CAPACITOR , CHIP	0.1uF 25V
C175, C176	HCUS1E104ZF	CAPACITOR , CHIP	0.1uF 25V
C178, C179	HCEA1VH100T	CAPACITOR , ELECT	10uF 35V
C180~C183	HCUS1H470JA	CAPACITOR , CHIP	47pF
C184~C187	HCEA1VH100T	CAPACITOR , ELECT	10uF 35V
C188, C189	HCUS1E104ZF	CAPACITOR , CHIP	0.1uF 25V
C196, C198	HCUS1E104ZF	CAPACITOR , CHIP	0.1uF 25V
C197	HCEA1HH220T	CAPACITOR , ELECT	22uF 50V
C199	HCEA1VH100T	CAPACITOR , ELECT	10uF 35V
C213, C214	HCEA1CH101T	CAPACITOR , ELECT	100uF 16V
C220~C222	HCUS1H471JA	CAPACITOR , CHIP	470pF
C225, C226	HCEA1CH101T	CAPACITOR , ELECT	100uF 16V
C227~C229	HCUS1H471JA	CAPACITOR , CHIP	470pF
C230	HCEA1CH220T	CAPACITOR , ELECT	22uF 16V
C231~C237	HCUS1H470JA	CAPACITOR , CHIP	47pF
C238~C245	HCUS1H470JA	CAPACITOR , CHIP	47pF
C246	HCEA1CH101T	CAPACITOR , ELECT	100uF 16V
C249, C250	HCEA1CH101T	CAPACITOR , ELECT	100uF 16V
C251	HCUS1E104ZF	CAPACITOR , CHIP	0.1uF 25V
C252, C253	HCEA1CH101T	CAPACITOR , ELECT	100uF 16V
C264	HCUS1H222KC	CAPACITOR , CHIP	2200pF
C265, C266	HCUS1H471JA	CAPACITOR , CHIP	470pF
C270~C273	HCUS1E104ZF	CAPACITOR , CHIP	0.1uF 25V
C278, C279	HCUS1H470JA	CAPACITOR , CHIP	47pF
C280, C281	HCEA1VH100T	CAPACITOR , ELECT	10uF 35V
C301~C306	HCUS1E104ZF	CAPACITOR , CHIP	0.1uF 25V
C313~C318	HCEA1VH100T	CAPACITOR , ELECT	10uF 35V
C319~C324	HCQI1H122JZT	CAPACITOR , MYLAR	1200pF 50V J
C325~C327	HCUS1H181JA	CAPACITOR , CHIP	180pF
C328	HCUS1H102KC	CAPACITOR , CHIP	1000pF
C329, C330	HCUS1H181JA	CAPACITOR , CHIP	180pF
C337~C342	HCQI1H122JZT	CAPACITOR , MYLAR	1200pF 50V J
C343~C348	HCEA1VH100T	CAPACITOR , ELECT	10uF 35V
C349, C350	HCUS1H181JA	CAPACITOR , CHIP	180pF
C357, C363	HCUS1H101JA	CAPACITOR , CHIP	100pF
C365~C368	HCUS1E104ZF	CAPACITOR , CHIP	0.1uF 25V
C377, C378	HCUS1H331JA	CAPACITOR , CHIP	330pF
C379, C380	HCEA1VH100T	CAPACITOR , ELECT	10uF 35V
C381, C382	HCUS1H103KC	CAPACITOR , CHIP	0.01uF
C383, C384	HCEA1CH101T	CAPACITOR , ELECT	100uF 16V
C385, C386	HCEA1VH100T	CAPACITOR , ELECT	10uF 35V
C392, C404	HCUS1E104ZF	CAPACITOR , CHIP	0.1uF 25V
C401	HCEA1AH471T	CAPACITOR , ELECT	470uF 10V
C402	HCEA1HH2R2T	CAPACITOR , ELECT	2.2uF 50V
C403	HCEA1CH221T	CAPACITOR , ELECT	220uF 16V
C405, C406	HCUS1H221JA	CAPACITOR , CHIP	220pF
C407	HCUS1H101JA	CAPACITOR , CHIP	100pF
C408	HCUS1H221JA	CAPACITOR , CHIP	220pF
C409	HCUS1H470JA	CAPACITOR , CHIP	47pF
C410	HCQI1H103JZT	CAPACITOR , MYLAR	0.01uF 50V J
C411~C413	HCUS1E104ZF	CAPACITOR , CHIP	0.1uF 25V
C414, C450	HCUS1H471JA	CAPACITOR , CHIP	470pF
C415~C418	HCEA1CH221T	CAPACITOR , ELECT	220uF 16V

LOAD NO.	PART NO.	DESCRIPTION	SPECIFICATION
C419, C420	HCUS1E104ZF	CAPACITOR , CHIP	0.1uF 25V
C421, C422	HCUS1H330JA	CAPACITOR , CHIP	33pF
C423, C424	HCUS1E104ZF	CAPACITOR , CHIP	0.1uF 25V
C425~C428	HCUS1H101JA	CAPACITOR , CHIP	100pF
C429	HCUS1E104ZF	CAPACITOR , CHIP	0.1uF 25V
C431~C434	HCEA1CH101T	CAPACITOR , ELECT	100uF 16V
C435, C436	HCEA1AH471T	CAPACITOR , ELECT	470uF 10V
C437, C452	HCEA1CH101T	CAPACITOR , ELECT	100uF 16V
C438~C440	HCUS1E104ZF	CAPACITOR , CHIP	0.1uF 25V
C441~C443	HRJ10DJ0R0T	RESISTOR , CHIP	JUMPER
C444, C447	HCUS1H330JA	CAPACITOR , CHIP	33pF
C445, C446	HCUS1E104ZF	CAPACITOR , CHIP	0.1uF 25V
C448, C449	HCUS1E104ZF	CAPACITOR , CHIP	0.1uF 25V
C451	HCUS1H330JA	CAPACITOR , CHIP	33pF
C453	HCEA1AH471T	CAPACITOR , ELECT	470uF 10V
C454, C455	HCUS1E104ZF	CAPACITOR , CHIP	0.1uF 25V
CN11, CN12	KJP23GA117ZG	WAFER , CARD CABLE	GF102-23S-TS
CN13	KJP13GA115ZG	WAFER, CARD CABLE	GF120-13S-TS
CN14	KJP12GA98ZM	WAFER	
CN91	KJP15GA117ZG	CARD CABLE , WAFER	15P 1M/M S/T
D101~D103	HVD1SS133MT	DIODE	1SS133T-77
D172~D177	HVD1SS133MT	DIODE	1SS133T-77
D186, D187	HVDMTZJ7.5AT	DIODE , ZENER	7.5V 1/2W
D401	HVDMTZJ3.3BT	DIODE , ZENER	3.3V 1/2W
D402	HVDMTZJ4.3CT	DIODE , ZENER	4.3V 1/2W
IC11	HVITC9164AF	I.C , FUNCTION	TC9164AF
IC12	HVITC9162AF	I.C , FUNCTION	TC9162AF
IC13	HVIM62446AFP	I.C , VOLUME	M62446AFP
IC14	HVINJU3713G	I.C , EXPANDER	NJU3713G
IC15	HVI74LCX08MX	I.C , AND GATE(QUAD/2IN LV)	74LCX08MX
IC16	BVIOPA2134UA	OP AMP	OPA2134UA
IC17~IC19	HVINJM2068MDTE1	I.C , OP AMP	NJM2068MD-TE1
IC20~IC21	BVIOPA2134UA	OP AMP	OPA2134UA
IC22	HVINJM2068MDTE1	I.C , OP AMP	NJM2068MD-TE1
IC41	HVICS493264-CL	I.C , DSP	CS493264
IC42	HVIK4586VQ	I.C, DIR+CODEC	AK4586
IC43	HVITC74HCU04AFN	I.C , INVERTER	TC74HCU04AFN
IC44	HVI74ACT04SC	I.C , HEX INVERTER	74ACT04SC
IC45, IC50	BVIOPA2134UA	OP AMP	OPA2134UA
IC46~IC49	HVINJM2068MDTE1	I.C , OP AMP	NJM2068MD-TE1
JK11	CJJ4R020Z	JACK , BOARD	GOLD. PLATE
JK12	CJJ4R035Z	JACK , BOARD	
JK14	CJJ4M042Z	JACK , BOARD	RCA-115AG-01
JK15	CJJ2D008Z	JACK , STEREO	
JK41	CJJ4M044Z	JACK, BOARD	
JK42	HJSTORX179	MODULE , OPTICAL(RECEIVE)	TORX179
JK43	HJS9L001Z	MODULE, OPTICAL	TOTX178
L401~L409	HLZ9J003Z	BEAD , FERRITE(CHIP)	BLM21A121SPT
Q104~Q107	HVTKRC102S	TRANSISTOR , CHIP	KRC102S
Q109, Q112	HVTKRA102S	TRANSISTOR , CHIP	KRA102S
Q110	HVTKRC102S	TRANSISTOR , CHIP	KRC102S
Q113~Q116	HVTKRC102S	TRANSISTOR , CHIP	KRC102S
Q117	HVTKRA102S	TRANSISTOR , CHIP	KRA102S
Q165~Q170	HVTKTD1304T	TRANSISTOR , CHIP (MUTE)	KTD1304
Q173~Q175	HVTKRA102S	TRANSISTOR , CHIP	KRA102S

LOAD NO.	PART NO.	DESCRIPTION	SPECIFICATION
Q194, Q195	HVTKTD1304T	TRANSISTOR , CHIP (MUTE)	KTD1304
Q401, Q402	HVTKSC2316YT	TRANSISTOR	KSC2316Y
R101~R106	HRJ10DJ471T	RESISTOR , CHIP	70 OHM 1/10W
R107~R112	HRJ10DJ102T	RESISTOR , CHIP	1K OHM 1/10W
R113~R118	HRJ10DJ224T	RESISTOR , CHIP	220K OHM 1/10W
R119~R125	HRJ10DJ473T	RESISTOR , CHIP	47K OHM 1/10W
R126~R131	HRJ10DJ121T	RESISTOR , CHIP	120 OHM 1/10W
R132, R133	HRJ10DJ223T	RESISTOR , CHIP	22K OHM 1/10W
R134~R137	HRJ10DJ473T	RESISTOR , CHIP	47K OHM 1/10W
R138	HRJ10DJ472T	RESISTOR , CHIP	4K7 OHM 1/10W
R139	HRJ10DJ332T	RESISTOR , CHIP	3K3 OHM 1/10W
R140, R141	HRJ10DJ472T	RESISTOR , CHIP	4K7 OHM 1/10W
R143, R144	HRJ10DJ223T	RESISTOR , CHIP	22K OHM 1/10W
R145	HRJ10DJ333T	RESISTOR , CHIP	33K OHM 1/10W
R146, R147	HRJ10DJ203T	RESISTOR , CHIP	20K OHM 1/10W
R148	HRJ10DJ331T	RESISTOR , CHIP	330 OHM 1/10W
R149	HRJ10DJ203T	RESISTOR , CHIP	20K OHM 1/10W
R150~R154	HRJ10DJ331T	RESISTOR , CHIP	330 OHM 1/10W
R155, R156	HRJ10DJ472T	RESISTOR , CHIP	4K7 OHM 1/10W
R157~R162	HRJ10DJ473T	RESISTOR , CHIP	47K OHM 1/10W
R163~R168	HRJ10DJ562T	RESISTOR , CHIP	5K6 OHM 1/10W
R169~R172	HRJ10DJ224T	RESISTOR , CHIP	220K OHM 1/10W
R173	HRJ10DJ103T	RESISTOR , CHIP	10K OHM 1/10W
R174, R175	HRJ10DJ121T	RESISTOR , CHIP	120 OHM 1/10W
R176	HRJ10DJ333T	RESISTOR , CHIP	33K OHM 1/10W
R177, R178	HRJ10DJ121T	RESISTOR , CHIP	120 OHM 1/10W
R179	HRJ10DJ333T	RESISTOR , CHIP	33K OHM 1/10W
R180, R181	HRJ10DJ104T	RESISTOR , CHIP	100K OHM 1/10W
R182, R183	HRJ10DJ203T	RESISTOR , CHIP	20K OHM 1/10W
R184, R185	HRJ10DJ333T	RESISTOR , CHIP	33K OHM 1/10W
R186~R189	HRJ10DJ104T	RESISTOR , CHIP	100K OHM 1/10W
R190, R191	HRJ10DJ224T	RESISTOR , CHIP	220K OHM 1/10W
R192, R193	HRJ10DJ121T	RESISTOR , CHIP	120 OHM 1/10W
R194, R195	HRJ10DJ331T	RESISTOR , CHIP	330 OHM 1/10W
R196, R197	HRJ10DJ562T	RESISTOR , CHIP	5K6 OHM 1/10W
R198	HRJ10DJ473T	RESISTOR , CHIP	47K OHM 1/10W
R199	HRJ10DJ121T	RESISTOR , CHIP	120 OHM 1/10W
R200	HRJ10DJ224T	RESISTOR , CHIP	220K OHM 1/10W
R201	HRJ10DJ103T	RESISTOR , CHIP	10K OHM 1/10W
R203	HRJ10DJ100T	RESISTOR , CHIP	10 OHM 1/10W
R204	HRJ10DJ103T	RESISTOR , CHIP	10K OHM 1/10W
R206	HRJ10DJ332T	RESISTOR , CHIP	3K3 OHM 1/10W
R210, R211	HRJ10DJ682T	RESISTOR , CHIP	6K8 OHM 1/10W
R212, R213	HRJ10DJ121T	RESISTOR , CHIP	120 OHM 1/10W
R214, R215	HRJ10DJ104T	RESISTOR , CHIP	100K OHM 1/10W
R216, R217	HRJ10DJ333T	RESISTOR , CHIP	33K OHM 1/10W
R218, R219	HRJ10DJ103T	RESISTOR , CHIP	10K OHM 1/10W
R220~R222	HRJ10DJ471T	RESISTOR , CHIP	470 OHM 1/10W
R223, R224	HRJ10DJ273T	RESISTOR , CHIP	27K OHM 1/10W
R225, R226	HRJ10DJ121T	RESISTOR , CHIP	120 OHM 1/10W
R227~R229	HRJ10DJ471T	RESISTOR , CHIP	470 OHM 1/10W
R230	HRJ10DJ271T	RESISTOR , CHIP	270 OHM 1/10W
R231~R234	HRJ10DJ680T	RESISTOR , CHIP	68 OHM 1/10W
R235~R237	HRJ10DJ681T	RESISTOR , CHIP	680 OHM 1/10W
R238~R245	HRJ10DJ680T	RESISTOR , CHIP	68 OHM 1/10W

LOAD NO.	PART NO.	DESCRIPTION	SPECIFICATION
R246	HRJ10DJ121T	RESISTOR , CHIP	120 OHM 1/10W
R247~R250	CRD20TJ331T	RESISTOR , CARBON	330 OHM 1/5W J
R251	HRJ10DJ471T	RESISTOR , CHIP	470 OHM 1/10W
R252	HRJ10DJ121T	RESISTOR , CHIP	120 OHM 1/10W
R253~R255	HRJ10DJ1R0T	RESISTOR , CHIP	1 OHM 1/10W
R256~R260	HRJ10DJ680T	RESISTOR , CHIP	68 OHM 1/10W
R262	HRJ10DJ470T	RESISTOR , CHIP	47 OHM 1/10W
R263	HRJ10DJ121T	RESISTOR , CHIP	120 OHM 1/10W
R264	HRJ10DJ102T	RESISTOR , CHIP	1K OHM 1/10W
R265, R266	HRJ10DJ4R7T	RESISTOR , CHIP	4R7 OHM 1/10W
R267, R270	HRJ10DJ121T	RESISTOR , CHIP	120 OHM 1/10W
R271	HRJ10DJ680T	RESISTOR , CHIP	68 OHM 1/10W
R272, R273	HRJ10DJ121T	RESISTOR , CHIP	120 OHM 1/10W
R274~R275	HRJ10DJ473T	RESISTOR , CHIP	47K OHM 1/10W
R276, R277	HRJ10DJ333T	RESISTOR , CHIP	33K OHM 1/10W
R278, R279	HRJ10DJ203T	RESISTOR , CHIP	20K OHM 1/10W
R280, R281	HRJ10DJ471T	RESISTOR , CHIP	470 OHM 1/10W
R282, R284	HRJ10DJ332T	RESISTOR , CHIP	3K3 OHM 1/10W
R283, R285	HRJ10DJ473T	RESISTOR , CHIP	47K OHM 1/10W
R286, R288	HRJ10DJ332T	RESISTOR , CHIP	3K3 OHM 1/10W
R287, R289	HRJ10DJ473T	RESISTOR , CHIP	47K OHM 1/10W
R301~R306	HRJ10DJ121T	RESISTOR , CHIP	120 OHM 1/10W
R307~R312	HRJ10DJ473T	RESISTOR , CHIP	47K OHM 1/10W
R313~R315	HRJ10DJ622T	RESISTOR , CHIP	6K2 OHM 1/10W
R316	HRJ10DJ332T	RESISTOR , CHIP	3K3 OHM 1/10W
R317, R318	HRJ10DJ622T	RESISTOR , CHIP	6K2 OHM 1/10W
R319~R324	HRJ10DJ102T	RESISTOR , CHIP	1K OHM 1/10W
R325~R330	HRJ10DJ153T	RESISTOR , CHIP	15K OHM 1/10W
R331~R333	HRJ10DJ332T	RESISTOR , CHIP	3K3 OHM 1/10W
R334	HRJ10DJ102T	RESISTOR , CHIP	1K OHM 1/10W
R335, R336	HRJ10DJ332T	RESISTOR , CHIP	3K3 OHM 1/10W
R337~R342	HRJ10DJ181T	RESISTOR , CHIP	180 OHM 1/10W
R343~R348	HRJ10DJ473T	RESISTOR , CHIP	47K OHM 1/10W
R349, R350	HRJ10DJ562T	RESISTOR , CHIP	5K6 OHM 1/10W
R351, R352	HRJ10DJ472T	RESISTOR , CHIP	4K7 OHM 1/10W
R357, R358	HRJ10DJ682T	RESISTOR , CHIP	6K8 OHM 1/10W
R363	HRJ10DJ103T	RESISTOR , CHIP	10K OHM 1/10W
R364	HRJ10DJ273T	RESISTOR , CHIP	27K OHM 1/10W
R365~R368	HRJ10DJ121T	RESISTOR , CHIP	120 OHM 1/10W
R371, R372	HRJ10DJ121T	RESISTOR , CHIP	120 OHM 1/10W
R373, R374	HRJ10DJ104T	RESISTOR , CHIP	100K OHM 1/10W
R375, R376	HRJ10DJ471T	RESISTOR , CHIP	470 OHM 1/10W
R377, R378	HRJ10DJ562T	RESISTOR , CHIP	5K6 OHM 1/10W
R379, R380	HRJ10DJ103T	RESISTOR , CHIP	10K OHM 1/10W
R381, R382	HRJ10DJ102T	RESISTOR , CHIP	1K OHM 1/10W
R401~R410	HRJ10DJ103T	RESISTOR , CHIP	10K OHM 1/10W
R411, R412	HRJ10DJ471T	RESISTOR , CHIP	470 OHM 1/10W
R413, R414	HRJ10DJ332T	RESISTOR , CHIP	3K3 OHM 1/10W
R415~R420	HRJ10DJ330T	RESISTOR , CHIP	33 OHM 1/10W
R421, R422	HRJ10DJ472T	RESISTOR , CHIP	4K7 OHM 1/10W
R423, R426	HRJ10DJ102T	RESISTOR , CHIP	1K OHM 1/10W
R424, R428	HRJ10DJ330T	RESISTOR , CHIP	33 OHM 1/10W
R425, R432	HRJ10DJ333T	RESISTOR , CHIP	33K OHM 1/10W
R427, R449	HRJ10DJ103T	RESISTOR , CHIP	10K OHM 1/10W
R430~R431	HRJ10DJ330T	RESISTOR , CHIP	33 OHM 1/10W

LOAD NO.	PART NO.	DESCRIPTION	SPECIFICATION
R434	HRJ10DJ0R0T	RESISTOR , CHIP	JUMPER
R438~R440	HRJ10DJ1R0T	RESISTOR , CHIP	1 OHM 1/10W
R441	HRJ10DJ330T	RESISTOR , CHIP	33 OHM 1/10W
R442~R444	HRJ10DJ4R7T	RESISTOR , CHIP	4R7 OHM 1/10W
R445	HRJ10DJ331T	RESISTOR , CHIP	330 OHM 1/10W
R446	HRJ10DJ105T	RESISTOR , CHIP	1M OHM 1/10W
R447	HRJ10DJ1R0T	RESISTOR , CHIP	1 OHM 1/10W
R448	HRJ10DJ102T	RESISTOR , CHIP	1K OHM 1/10W
R450	HRJ10DJ183T	RESISTOR , CHIP	18K OHM 1/10W
R451, R452	HRJ10DJ4R7T	RESISTOR , CHIP	4R7 OHM 1/10W
R453, R455	HRJ10DJ470T	RESISTOR , CHIP	47 OHM 1/10W
R456	HRJ10DJ4R7T	RESISTOR , CHIP	4R7 OHM 1/10W
R457	HRJ10DJ100T	RESISTOR , CHIP	10 OHM 1/10W
R458	HRJ10DJ750T	RESISTOR , CHIP	75 OHM 1/10W
R459	HRJ10DJ100T	RESISTOR , CHIP	10 OHM 1/10W
R460	HRJ10DJ472T	RESISTOR , CHIP	4K7 OHM 1/10W
R461~R464	HRJ10DJ100T	RESISTOR , CHIP	10 OHM 1/10W
R468~R470	HRJ10DJ104T	RESISTOR , CHIP	100K OHM 1/10W
R471	HRJ10DJ100T	RESISTOR , CHIP	10 OHM 1/10W
R472	HRJ10DJ750T	RESISTOR , CHIP	75 OHM 1/10W
R473, R474	HRJ10DJ471T	RESISTOR , CHIP	470 OHM 1/10W
R475,R476	HRJ10DJ102T	RESISTOR , CHIP	1K OHM 1/10W
R477	HRJ10DJ471T	RESISTOR , CHIP	470 OHM 1/10W
X401	HOX12288E220TF	CRYSTAL(HC-49/S,ATS)	12.288MHZ
	CUP11554-2	VIDEO PCB	
BN41	KJP12GB99ZM	CONNECTOR	
BN85	CWB1C911200EN	WIRE ASS'Y	
BN90	CWZL70BN90	WIRE ASS'Y	
C501~C506	HCUS1H181JA	CAPACITOR , CHIP	180pF
C507~C512	HCUS1H271JA	CAPACITOR , CHIP	270pF
C513~C518	HCEA1VH100T	CAPACITOR , ELECT	10uF 35V
C519~C521	HCEA1AH471T	CAPACITOR , ELECT	470uF 10V
C522~C524	HCUS1H271JA	CAPACITOR , CHIP	270pF
C525~C530	HCEA1CH101T	CAPACITOR , ELECT	100uF 16V
C531~C536	HCUS1H103KC	CAPACITOR , CHIP	0.01uF
C537, C539	HCEA1AH471T	CAPACITOR , ELECT	470uF 10V
C538	HCUS1H181JA	CAPACITOR , CHIP	180pF
C540	HCEA1VH100T	CAPACITOR , ELECT	10uF 35V
C541, C542	HCEA1AH471T	CAPACITOR , ELECT	470uF 10V
C543, C544	HCUS1H103KC	CAPACITOR , CHIP	0.01uF
C545	HCEA1CH471T	CAPACITOR , ELECT	470uF 16V
C546~C550	HCUS1H470JA	CAPACITOR , CHIP	47pF
C551	HCUS1H220JA	CAPACITOR , CHIP	22pF
C552~C562	HCUS1H471JA	CAPACITOR , CHIP	470pF
C563~C565	HCUS1H101JA	CAPACITOR , CHIP	100pF
C566, C567	HCUS1H220JA	CAPACITOR , CHIP (C VER.)	22pF
	HCUS1H100JA	CAPACITOR , CHIP (AH VER.)	10pF
C568	HCEA1HHR47T	CAPACITOR , ELECT	R47uF 50V
C569	HCEA1HH1R0T	CAPACITOR , ELECT	1uF 50V
C570	HCEA1CH101T	CAPACITOR , ELECT	100uF 16V
C571, C572	HCUS1H223KC	CAPACITOR , CHIP	0.022uF
C573, C574	HCUS1H270JA	CAPACITOR , CHIP	27pF
C575	HCEA1HH1R0T	CAPACITOR , ELECT	1uF 50V
C576	HCQ11H682JZT	CAPACITOR , MYLAR	6800pF 50V J

LOAD NO.	PART NO.	DESCRIPTION	SPECIFICATION
C577	HCUS1H181JA	CAPACITOR , CHIP	180pF
C578	HCUS1H470JA	CAPACITOR , CHIP	47pF
C579	HCEA1HH1R0T	CAPACITOR , ELECT	1uF 50V
C580, C581	HCEA1AH471T	CAPACITOR , ELECT	470uF 10V
C582, C583	HCUS1H820JA	CAPACITOR , CHIP	82pF
C584	HCEA1AH471T	CAPACITOR , ELECT	470uF 10V
C585~C587	HCEA1VH100T	CAPACITOR , ELECT	10uF 35V
C588~C589	HCEA1CH101T	CAPACITOR , ELECT	100uF 16V
C590	HCEA1HH1R0T	CAPACITOR , ELECT	1uF 50V
CE31	HCEA1AH471T	CAPACITOR , ELECT (C VER.)	470uF 10V
CE32	HCUS1H181JA	CAPACITOR , CHIP (C VER.)	180pF
CE33	HCUS1E104ZF	CAPACITOR , CHIP (C VER.)	0.1uF 25V
CN42	KJP15GA115ZG	WAFER , CARD CABLE	GF120-15S-TS
CN44	KJP23GA117ZG	WAFER , CARD CABLE	GF102-23S-TS
CN89	KJP05GA19ZM	WAFER	MOLEX53014-0510
CN92	KJP17GA117ZG	WAFER , CARD CABLE	GF102-17S-TS
D551	HVDMTZJ5.1BT	DIODE , ZENER	5.1V 1/2W
D552	HVDMTZJ5.1BT	DIODE , ZENER	5.1V 1/2W
D553	HVD1SS133MT	DIODE	1SS133T-77
IC51~IC53	HVINJM2296M	I.C , VIDEO SW	NJM2296M
IC54	HVILC74763M	I.C , OSD	LC74763
JK51~JK54	CJJ9N003Z	JACK , (S-VIDEO+VHS)	
JK55	KJJ4S014Z	JACK , R.G.B (AH VER.)	
JK56	KJP21GA118ZP	SCART CONNECTOR (C VER.)	
L501~L504	HLQ02C1R8KT	COIL	1.8uH,K
L551	KLQ101J405T	COIL, PEAKING(RADIAL)	100uH J
L552	KLQ5R6J405T	COIL, PEAKING(RADIAL)	5.6uH J
L553	KLQ220J405T	COIL, PEAKING(RADIAL)	22uH J
LE31	HLQ02C1R8KT	COIL (C VER.)	1.8uH,K
Q551	KVTKSC2785YT	TRANSISTOR	KSC2785Y
Q552	KVTKSA1175YT	TRANSISTOR	KSA1175Y
Q553	HVTKSC2316YT	TRANSISTOR	KSC2316Y
Q554	HVTKSA916YT	TRANSISTOR	KSA916Y
QE31, QE32	KVTKSA733CYT	TRANSISTOR (C VER.)	KSA733CY
QE33	HVTKRC102S	TRANSISTOR , CHIP (C VER.)	KRC102S
QE34, QE35	HVTKTD1304T	TRANSISTOR , CHIP (C VER.)	KTD1304
QE36	HVTKRA102S	TRANSISTOR , CHIP (C VER.)	KRA102S
R501~R512	HRJ10DJ750T	RESISTOR , CHIP	75 OHM 1/10W
R513~R518	HRJ10DJ223T	RESISTOR , CHIP	22K OHM 1/10W
R519~R524	HRJ10DJ4R7T	RESISTOR , CHIP	4R7 OHM 1/10W
R525~R527	HRJ10DJ750T	RESISTOR , CHIP	75 OHM 1/10W
R528, R529	HRJ10DJ102T	RESISTOR , CHIP	1K OHM 1/10W
R530, R531	KRG2ANJ470H	RESISTOR , METAL OXIDE FILM	47 OHM 2W J
R532	HRJ10DJ4R7T	RESISTOR , CHIP	4R7 OHM 1/10W
R533~R546	HRJ10DJ680T	RESISTOR , CHIP	68 OHM 1/10W
R547, R548	HRJ10DJ121T	RESISTOR , CHIP	120 OHM 1/10W
R549	HRJ10DJ680T	RESISTOR , CHIP	68 OHM 1/10W
R551~R553	HRJ10DJ102T	RESISTOR , CHIP	1K OHM 1/10W
R554	HRJ10DJ750T	RESISTOR , CHIP	75 OHM 1/10W
R555	HRJ10DJ682T	RESISTOR , CHIP	6K8 OHM 1/10W
R556	HRJ10DJ332T	RESISTOR , CHIP	3K3 OHM 1/10W
R557	HRJ10DJ822T	RESISTOR , CHIP	8K2 OHM 1/10W
R558	HRJ10DJ181T	RESISTOR , CHIP	180 OHM 1/10W
R559	HRJ10DJ103T	RESISTOR , CHIP	10K OHM 1/10W
R560	HRJ10DJ222T	RESISTOR , CHIP	2K2 OHM 1/10W

LOAD NO.	PART NO.	DESCRIPTION	SPECIFICATION
R561	HRJ10DJ393T	RESISTOR , CHIP	39K OHM 1/10W
R562	HRJ10DJ152T	RESISTOR , CHIP	1K5 OHM 1/10W
R563	HRJ10DJ682T	RESISTOR , CHIP	6K8 OHM 1/10W
R564, R565	HRJ10DJ102T	RESISTOR , CHIP	1K OHM 1/10W
R566	HRJ10DJ104T	RESISTOR , CHIP	100K OHM 1/10W
R567~R569	HRJ10DJ562T	RESISTOR , CHIP	5K6 OHM 1/10W
R570	HRJ10DJ102T	RESISTOR , CHIP	1K OHM 1/10W
R580	HRJ10DJ0R0T	RESISTOR , CHIP (AH VER.)	JUMPER
RE31	HRJ10DJ101T	RESISTOR , CHIP (C VER.)	100 OHM 1/10W
RE32	HRJ10DJ271T	RESISTOR , CHIP (C VER.)	270 OHM 1/10W
RE33, RE34	HRJ10DJ102T	RESISTOR , CHIP (C VER.)	1K OHM 1/10W
RE35, RE36	HRJ10DJ331T	RESISTOR , CHIP (C VER.)	330 OHM 1/10W
RE37, RE38	HRJ10DJ562T	RESISTOR , CHIP (C VER.)	5K6 OHM 1/10W
RE39, RE40	HRJ10DJ680T	RESISTOR , CHIP (C VER.)	68 OHM 1/10W
RE41, RE42	HRJ10DJ102T	RESISTOR , CHIP (C VER.)	1K OHM 1/10W
RE43, RE44	HRJ10DJ750T	RESISTOR , CHIP (C VER.)	75 OHM 1/10W
RE45	HRJ10DJ224T	RESISTOR , CHIP (C VER.)	220K OHM 1/10W
SW51	KSS2D004Z	SW , SLIDE	JSS4208A
X501	HOX17744D220F	CRYSTAL (C VER.)	17.744MHz
	HOX14318D220F	CRYSTAL (AH VER.)	14.318MHz
	CUP11555	AMP PCB ASS'Y	
BN51	KJP08GB99ZM	CONNECTOR , HOUSING	MOLEX35237-0810
BN52	KJP08GB99ZM	CONNECTOR , HOUSING	MOLEX35237-0810
C551, C552	HCEA1HH100T	CAPACITOR , ELECT	10uF 50V
C554~C556	HCEA1HH100T	CAPACITOR , ELECT	10uF 50V
C557, C558	HCEA1EH330T	CAPACITOR , ELECT	33uF 25V
C560~C562	HCEA1EH330T	CAPACITOR , ELECT	33uF 25V
C563, C564	CCKT1H471KB	CAPACITOR , CERAMIC	470pF 50V KB
C566~C568	CCKT1H471KB	CAPACITOR , CERAMIC	470pF 50V KB
C569, C570	HCEA1EH220T	CAPACITOR , ELECT	22uF 50V
C572~C574	HCEA1EH220T	CAPACITOR , ELECT	22uF 50V
C623, C624	HCEA1AH101T	CAPACITOR , ELECT	100uF 10V
C626~C628	HCEA1AH101T	CAPACITOR , ELECT	100uF 10V
C671, C672	HCBS1H5R6KCT	CAPACITOR , CERAMIC	5.6pF 50V K
C674~C676	HCBS1H5R6KCT	CAPACITOR , CERAMIC	5.6pF 50V K
C678	CCKT1H181KB	CAPACITOR , CERAMIC	180pF 50V KB
C680~C683	CCKT1H181KB	CAPACITOR , CERAMIC	180pF 50V KB
C713, C714	HCEA1JH221E	CAPACITOR , ELECT	220uF 63V
C716~C720	HCEA1JH221E	CAPACITOR , ELECT	220uF 63V
C722~C724	HCEA1JH221E	CAPACITOR , ELECT	220uF 63V
C737~C738	HCEA1HH1R0T	CAPACITOR , ELECT	1uF 50V
C740~C742	HCEA1HH1R0T	CAPACITOR , ELECT	1uF 50V
C785, C786	HCEA1HH100T	CAPACITOR , ELECT	10uF 50V
C788~C790	HCEA1HH100T	CAPACITOR , ELECT	10uF 50V
CN13	KJP13GA115ZG	WAFER, CARD CABLE	GF120-13S-TS
CN51, CN52	KJP08GA98ZM	WAFER	MOLEX35336-0810
CN54~CN59	BJP06GB131ZK	CONNECTOR(PLUG)	TAC-L06P-B3
D557, D558	HVD1SS133MT	DIODE	1SS133T-77
D560~D562	HVD1SS133MT	DIODE	1SS133T-77
D629, D630	HVD1SS133MT	DIODE	1SS133T-77
D632~D634	HVD1SS133MT	DIODE	1SS133T-77
Q575, Q576	HVTKTA1268GRT	TRANSISTOR	KTA1268GR
Q578~Q582	HVTKTA1268GRT	TRANSISTOR	KTA1268GR
Q584~Q588	HVTKTA1268GRT	TRANSISTOR	KTA1268GR

LOAD NO.	PART NO.	DESCRIPTION	SPECIFICATION
Q590~Q594	HVTKTA1268GRT	TRANSISTOR	KTA1268GR
Q596~Q598	HVTKTA1268GRT	TRANSISTOR	KTA1268GR
Q641, Q642	HVTKTC3200GRT	TRANSISTOR	KTC3200GR
Q644~Q646	HVTKTC3200GRT	TRANSISTOR	KTC3200GR
Q647, Q648	HVTKTA1268GRT	TRANSISTOR	KTA1268GR
Q650~Q652	HVTKTA1268GRT	TRANSISTOR	KTA1268GR
Q665, Q666	HVTKTC3200GRT	TRANSISTOR	KTC3200GR
Q668~Q670	HVTKTC3200GRT	TRANSISTOR	KTC3200GR
Q683, Q684	HVTKTC3114A	TRANSISTOR , BIAS	KTC3114A
Q686~Q688	HVTKTC3114A	TRANSISTOR , BIAS	KTC3114A
Q701, Q702	HVTKTA1360Y	TRANSISTOR , PRE DRIVE	KTA1360Y
Q704~Q706	HVTKTA1360Y	TRANSISTOR , PRE DRIVE	KTA1360Y
Q707, Q708	HVTKTC3423Y	TRANSISTOR , PRE DRIVE	KTC3423Y
Q710~Q712	HVTKTC3423Y	TRANSISTOR , PRE DRIVE	KTC3423Y
Q743, Q744	BVT2SD2389P-OKM	TRANSISTOR , POWER	2SD2389P-OKM
Q746~Q748	BVT2SD2389P-OKM	TRANSISTOR , POWER	2SD2389P-OKM
Q749, Q750	BVT2SB1559P-OKM	TRANSISTOR , POWER	2SB1559P-OKM
Q752~Q754	BVT2SB1559P-OKM	TRANSISTOR , POWER	2SB1559P-OKM
Q791, Q792	KVTKSC2785YT	TRANSISTOR	KSC2785Y
Q794~Q796	KVTKSC2785YT	TRANSISTOR	KSC2785Y
R551, R552	CRD20TJ102T	RESISTOR , CARBON	1K OHM 1/5W J
R554~R556	CRD20TJ102T	RESISTOR , CARBON	1K OHM 1/5W J
R557, R558	CRD20TJ333T	RESISTOR , CARBON	33K OHM 1/5W J
R560~R564	CRD20TJ333T	RESISTOR , CARBON	33K OHM 1/5W J
R566~R568	CRD20TJ333T	RESISTOR , CARBON	33K OHM 1/5W J
R569, R570	CRD20TJ103T	RESISTOR , CARBON	10K OHM 1/5W J
R572~R574	CRD20TJ103T	RESISTOR , CARBON	10K OHM 1/5W J
R575, R576	CRD20TJ181T	RESISTOR , CARBON	180 OHM 1/5W J
R578~R580	CRD20TJ181T	RESISTOR , CARBON	180 OHM 1/5W J
R581, R582	CRD20TJ103T	RESISTOR , CARBON	10K OHM 1/5W J
R584~R586	CRD20TJ103T	RESISTOR , CARBON	10K OHM 1/5W J
R587, R588	CRD20TJ150T	RESISTOR , CARBON	15 OHM 1/5W J
R590~R594	CRD20TJ150T	RESISTOR , CARBON	15 OHM 1/5W J
R596~R598	CRD20TJ150T	RESISTOR , CARBON	15 OHM 1/5W J
R605, R606	CRD20TJ152T	RESISTOR , CARBON	1.5K OHM 1/5W J
R608~R612	CRD20TJ152T	RESISTOR , CARBON	1.5K OHM 1/5W J
R614~R616	CRD20TJ152T	RESISTOR , CARBON	1.5K OHM 1/5W J
R617, R618	CRD20TJ333T	RESISTOR , CARBON	33K OHM 1/5W J
R620~R622	CRD20TJ333T	RESISTOR , CARBON	33K OHM 1/5W J
R623, R624	CRD20TJ152T	RESISTOR , CARBON	1.5K OHM 1/5W J
R626~R628	CRD20TJ152T	RESISTOR , CARBON	1.5K OHM 1/5W J
R629, R630	CRD20TJ471T	RESISTOR , CARBON	470 OHM 1/5W J
R632~R634	CRD20TJ471T	RESISTOR , CARBON	470 OHM 1/5W J
R635, R636	CRD20TJ561T	RESISTOR , CARBON	560 OHM 1/5W J
R638~R642	CRD20TJ561T	RESISTOR , CARBON	560 OHM 1/5W J
R644, R648	CRD20TJ561T	RESISTOR , CARBON	560 OHM 1/5W J
R650~R652	CRD20TJ561T	RESISTOR , CARBON	560 OHM 1/5W J
R653, R654	CRD20TJ472T	RESISTOR , CARBON	4.7K OHM 1/5W J
R656~R660	CRD20TJ472T	RESISTOR , CARBON	4.7K OHM 1/5W J
R662~R664	CRD20TJ472T	RESISTOR , CARBON	4.7K OHM 1/5W J
R665, R666	CRD20TJ561T	RESISTOR , CARBON	560 OHM 1/5W J
R668~R670	CRD20TJ561T	RESISTOR , CARBON	560 OHM 1/5W J
R671, R672	CRD20TJ223T	RESISTOR , CARBON	22K OHM 1/5W J
R674~R678	CRD20TJ223T	RESISTOR , CARBON	22K OHM 1/5W J
R680~R682	CRD20TJ223T	RESISTOR , CARBON	22K OHM 1/5W J

LOAD NO.	PART NO.	DESCRIPTION	SPECIFICATION
R683, R684	CRD20TJ561T	RESISTOR , CARBON	560 OHM 1/5W J
R686~R688	CRD20TJ561T	RESISTOR , CARBON	560 OHM 1/5W J
R689, R690	CRD20TJ152T	RESISTOR , CARBON	1.5K OHM 1/5W J
R692~R694	CRD20TJ152T	RESISTOR , CARBON	1.5K OHM 1/5W J
R701, R702	CRD20TJ121T	RESISTOR , CARBON	120 OHM 1/5W J
R704~R708	CRD20TJ121T	RESISTOR , CARBON	120 OHM 1/5W J
R710~R712	CRD20TJ121T	RESISTOR , CARBON	120 OHM 1/5W J
R713, R714	CRD20TJ330T	RESISTOR , CARBON	33 OHM 1/5W J
R716~R720	CRD20TJ330T	RESISTOR , CARBON	33 OHM 1/5W J
R71L, R71R	KRF5EKR22	RESISTOR , CEMENT	0.22 OHM 5W K
R722~R724	CRD20TJ330T	RESISTOR , CARBON	33 OHM 1/5W J
R72L, R72R	KRF5EKR22	RESISTOR , CEMENT	0.22 OHM 5W K
R73C, R74C	KRF5EKR22	RESISTOR , CEMENT	0.22 OHM 5W K
R75S~R78S	KRF5EKR22	RESISTOR , CEMENT	0.22 OHM 5W K
R773, R774	CRD20TJ102T	RESISTOR , CARBON	1K OHM 1/5W J
R776~R780	CRD20TJ102T	RESISTOR , CARBON	1K OHM 1/5W J
R782~R784	CRD20TJ102T	RESISTOR , CARBON	1K OHM 1/5W J
R785, R786	CRD20TJ472T	RESISTOR , CARBON	4.7K OHM 1/5W J
R788~R792	CRD20TJ472T	RESISTOR , CARBON	4.7K OHM 1/5W J
R794~R796	CRD20TJ472T	RESISTOR , CARBON	4.7K OHM 1/5W J
R797, R798	CRD20TJ224T	RESISTOR , CARBON	4.7K OHM 1/5W J
	HDMKD1206PTS3	MOTOR , FAN(60X60X25MM)	KD1206PTS3
	CUP11556-1	POWER PCB	
BN54~BN59	BJP06GA130ZK	CONNECTOR(SOCKET)	TAC-L06X-A3
BN84	CWB1C912130EN	WIRE ASS'Y	
BN95	CWB1E904150BM	WIRE ASS'Y	
BN97	CWB1C906120EN	WIRE ASS'Y	
C921	HCET16VFHS223ND	E-CAPACITOR FHS	22000uF 16V
C923	HCEA1CH101T	CAPACITOR , ELECT	100uF 16V
C930~C932	CCKT1H102KB	CAPACITOR , CERAMIC	1000pF 50V KB
C934, C935	CCKT1H102KB	CAPACITOR , CERAMIC	1000pF 50V KB
C936	HCEA1AH471T	CAPACITOR , ELECT	470uF 10V
C939~C942	CCKT1H473ZF	CAPACITOR , CERAMIC	0.047uF 50V ZF
C944	CCKT1H473ZF	CAPACITOR , CERAMIC	0.047uF 50V ZF
C945	CCKT1H103ZF	CAPACITOR , CERAMIC	0.01uF 50V ZF
C946, C947	CCKT1H102KB	CAPACITOR , CERAMIC	1000pF 50V KB
C948	CCKT1H471KB	CAPACITOR , CERAMIC	470pF 50V KB
C949	HCEA1HH4R7T	CAPACITOR , ELECT	4.7uF 50V
C950	HCEA1CH221T	CAPACITOR , ELECT	
C951	HCEA1CH471T	CAPACITOR , ELECT	
C952	CCKT1H471KB	CAPACITOR , CERAMIC	470pF 50V KB
C953	HCEA1HH100T	CAPACITOR , ELECT	10uF 50V
C954	HCEA1CH101T	CAPACITOR , ELECT	100uF 16V
C955, C956	HCEA1HH100T	CAPACITOR , ELECT	10uF 50V
C957	HCET63VFHS153ND	CAPACITOR , ELECT	15000uF/63V
C958, C959	CCKT1H103ZF	CAPACITOR , CERAMIC	0.01uF 50V ZF
C960	CCKT1H473ZF	CAPACITOR , CERAMIC	0.047uF 50V ZF
C961	HCET63VFHS153ND	CAPACITOR , ELECT	15000uF/63V
C962	CCKT1H473ZF	CAPACITOR , CERAMIC	0.047uF 50V ZF
C963	HCEA1VH100T	CAPACITOR , ELECT	10uF 35V
CN94	KJP03GA90ZM	WAFER	MOLEX35313-0310
CN98	KJP02GA01ZM	WAFER	MOLEX 5267-02A
D918~D921	HVD1SS133MT	DIODE	1SS133T-77
D924	BVDGBJ1504	DIODE , BRIDGE	GBJ1504

LOAD NO.	PART NO.	DESCRIPTION	SPECIFICATION
D925~D928	HVD1SS133MT	DIODE	1SS133T-77
JK91	CJJ5Q007Z	TERMINAL,SP(RRRR/BBBB)	
JK92	CJJ5N005Z	TERMINAL,SP(R/B)	
L926~L928	CLEY0R5KAK	COIL , SPEAKER	0.5uH K
L930, L931	CLEY0R5KAK	COIL , SPEAKER	0.5uH K
Q901	KVTKSC2785YT	TRANSISTOR	KSC2785Y
Q902	HVTKRA102MT	TRANSISTOR	KRA102M
Q903	HVTKTA1271YT	TRANSISTOR	KTA1271Y
Q904~Q907	KVTKSC2785YT	TRANSISTOR	KSC2785Y
Q908	HVTKSC2316YT	TRANSISTOR	KSC2316Y
R920	CRD20TJ104T	RESISTOR , CARBON	100K OHM 1/5W J
R922	CRD20TJ103T	RESISTOR , CARBON	10K OHM 1/5W J
R923	CRD20TJ332T	RESISTOR , CARBON	3.3K OHM 1/5W J
R926~R929	KRD25FJ100T	RESISTOR , CARBON	
R931	KRD25FJ100T	RESISTOR , CARBON	
R932, R933	CRD20TJ223T	RESISTOR , CARBON	22K OHM 1/5W J
R934	CRD20TJ102T	RESISTOR , CARBON	1K OHM 1/5W J
R935	CRD20TJ223T	RESISTOR , CARBON	22K OHM 1/5W J
R937, R938	CRD20TJ223T	RESISTOR , CARBON	22K OHM 1/5W J
R939~R942	CRD25TJ100T	RESISTOR , CARBON	
R944	CRD25TJ100T	RESISTOR , CARBON	
R945, R946	KRG1ANJ331H	RESISTOR , METAL OXIDE FILM	330 OHM 1W J
R947	CRD20TJ472T	RESISTOR , CARBON	4.7K OHM 1/5W J
R948	CRD20TJ333T	RESISTOR , CARBON	33K OHM 1/5W J
R949	CRD20TJ682T	RESISTOR , CARBON	6.8K OHM 1/5W J
R950	CRD20TJ182T	RESISTOR , CARBON	1.8K OHM 1/5W J
R951	CRD20TJ101T	RESISTOR , CARBON	100 OHM 1/5W J
R952	CRD20TJ393T	RESISTOR , CARBON	
R953	CRD20TJ562T	RESISTOR , CARBON	5.6K OHM 1/5W J
R954	CRD20TJ472T	RESISTOR , CARBON	4.7K OHM 1/5W J
R955	CRD20TJ101T	RESISTOR , CARBON	100 OHM 1/5W J
R956	CRD20TJ223T	RESISTOR , CARBON	22K OHM 1/5W J
R957, R958	CRD20TJ102T	RESISTOR , CARBON	1K OHM 1/5W J
R959	CRD20TJ562T	RESISTOR , CARBON	5.6K OHM 1/5W J
R960	CRD20TJ224T	RESISTOR , CARBON	
R961, R962	CRD20TJ333T	RESISTOR , CARBON	33K OHM 1/5W J
R963, R964	CRD20TJ223T	RESISTOR , CARBON	22K OHM 1/5W J
R965, R966	CRD20TJ474T	RESISTOR , CARBON	
RY92	HSL3A015ZE	RELAY	OSA-SS-212DM5
TH91	KRTP42T7D330B	THERMAL SENSOR , POSISTOR	P42T7D330BW20
	CUP11556-2	STANDBY TRANSFORMER ASS'Y	
BN98	CWB1C903170BM	WIRE ASS'Y	
C922	HCEA1EH470T	CAPACITOR , ELECT	47uF 25V
C924	HCEA1EH102E	CAPACITOR , ELECT	1000uF 25V
C926	CCKT1H103ZF	CAPACITOR , CERAMIC	0.01uF 50V ZF
CN91	KJP02KA060ZY	WAFER	7.92MM(YUNHO)
CN92	KJP02GA89ZM	WAFER	MOLEX35328-02
CN93	KJP03GA89ZM	WAFER	MOLEX35328-0310
CN95	KJP04GA01ZM	WAFER	MOLEX 5267-04A
D922	KVD1N4003ST	DIODE	1N4003
F901	KBA2C3150TLE	FUSE (C VER.)	
	KBA2C6300TLU	FUSE (AH VER.)	
IC97	HVIMC7806	6V REGULATOR	
R921	CRD20TJ100T	RESISTOR , CARBON	10 OHM 1/5W J

LOAD NO.	PART NO.	DESCRIPTION	SPECIFICATION
R990	BRDERC12UGK335T	RESISTOR , CARBON(AH VER.)	3.3M OHM 1/2W
RY91	HSL1A008ZE	RELAY	SDT-S-112DMR
T901	CLT5L053ZE	TRANSFORMER, SUB (C VER.)	
	CLT5L053ZU	TRANSFORMER, SUB (AH VER.)	
	CUP11556-3	CONNECTOR PCB	
BN14	KJP12GB99ZM	CONNECTOR	
CN41	KJP12GA98ZM	WAFER	
R967	CRD20TJ222T	RESISTOR , CARBON	2.2K OHM 1/5W J
R968	CRD20TJ222T	RESISTOR , CARBON	2.2K OHM 1/5W J
R969	CRD20TJ222T	RESISTOR , CARBON	2.2K OHM 1/5W J
	CUP11556-4	OUTLET PCB	
BN92	CWB4DA32130PU	WIRE , ASS'Y (C VER.)	
BN93	CWB4DA32130PU	WIRE , ASS'Y (AH VER.)	
F902	KBA2C1250TLE	FUSE(C VER.)	
F903	KBA2C2000TLU	FUSE(AH VER.)	
OL92	KJJ7A021Z	AC OUT LET 230V 1P (C VER.)	A302D0060P(1P)
OL93	KJJ7A012Z	AC OUT LET 120V 1P (AH VER.)	A302D0030P(1P)
	CIP11445BSMD	DVD MAIN PCB (CUP11445W)	139 * 72 (FR-4)
C101, C102	HCUS1E104ZF	CAPACITOR , CHIP	0.1uF
C103	HCEC0JRV2101T	CAPACITOR , CHIP ELECT	100uF/6.3V
C104	HCUS1E104ZF	CAPACITOR , CHIP	0.1uF
C105, C111	HCEC0JRV2101T	CAPACITOR , CHIP ELECT	100uF/6.3V
C112, C114	HCUS1E104ZF	CAPACITOR , CHIP	0.1uF
C116	HCEC0JRV2470T	CAPACITOR , CHIP ELECT	47uF/6.3V
C117, C118	HCUS1H270JA	CAPACITOR , CHIP	27pF
C120	HCUS1E104ZF	CAPACITOR , CHIP	0.1uF
C121	BCEC0JSE331T	CAPACITOR , CHIP ELECT	330uF/6.3
C123	HCUS1E104ZF	CAPACITOR , CHIP	0.1uF
C124	HCEC0JRV2101T	CAPACITOR , CHIP ELECT	100uF/6.3V
C142, C144	HCUS1E104ZF	CAPACITOR , CHIP	0.1uF
C146, C150	HCUS1E104ZF	CAPACITOR , CHIP	0.1uF
C152	HCUS1E104ZF	CAPACITOR , CHIP	0.1uF
C154~C156	HCUS1E104ZF	CAPACITOR , CHIP	0.1uF
C158~C160	HCUS1E104ZF	CAPACITOR , CHIP	0.1uF
C162	HCUS1E104ZF	CAPACITOR , CHIP	0.1uF
C163	HCUS1H151JA	CAPACITOR , CHIP	150pF
C164~C166	HCUS1E104ZF	CAPACITOR , CHIP	0.1uF
C168, C169	HCUS1E104ZF	CAPACITOR , CHIP	0.1uF
C171	HCUS1E104ZF	CAPACITOR , CHIP	0.1uF
C173	HCEC0JRV2101T	CAPACITOR , CHIP ELECT	100uF/6.3V
C178, C179	HCUS1E104ZF	CAPACITOR , CHIP	0.1uF
C186, C188	HCUS1E104ZF	CAPACITOR , CHIP	0.1uF
C190	HCEC0JRV2470T	CAPACITOR , CHIP ELECT	47uF/6.3V
C191, C192	HCUS1E104ZF	CAPACITOR , CHIP	0.1uF
C285	BCEC0JSE331T	CAPACITOR , CHIP ELECT	330uF/6.3
C286, C287	HCUS1E104ZF	CAPACITOR , CHIP	0.1uF
CN10	KJP23GA117ZG	WAFER , CARD CABLE	GF102-23S-TS
CN12	KJP40GB80ZP	40P HEADER (ANGLE TYPE)	2110DR40G
IC01	HVIES4318F	I.C , DVD MPEG DECODER	ES4318F
IC03	HVIHY29F400ABT7	FLASH MEMORY(4M)	HY29F400ABT70
IC07	HVI74VHC04MX	I.C , INVERTER	74VHC04M
IC08, IC09	HVIRC1117ST	I.C , ADJ REGULATOR	RC1117ST

LOAD NO.	PART NO.	DESCRIPTION	SPECIFICATION
IC10, IC11	HVIHY57V161610D	I.C , SDRAM(16M)	HY57V161610DTC8
IC13	HVIBR24C16F	I.C , EEPROM(16K)	2K*8 SOP8
IC14	HVICS4955	I.C , VIDEO ENCODER	CS4955
L101	HLZ9Z005Z	FERRITE CORE	6*10(A) + COIL
L102	HLZ9Z005Z	FERRITE CORE	6*10(A) + COIL
L104, L105	HRJ10DJ0R0T	RESISTOR , CHIP	JUMPER
R101	HRJ10DJ361T	RESISTOR , CHIP	360 OHM 1/10W
R106	HRJ10DJ0R0T	RESISTOR , CHIP	JUMPER
R107	HRJ10DJ472T	RESISTOR , CHIP	4K7 OHM 1/10W
R108	HRJ10DJ105T	RESISTOR , CHIP	1M OHM 1/10W
R109~R112	HRJ10DJ121T	RESISTOR , CHIP	120 OHM 1/10W
R113, R115	HRJ10DJ221T	RESISTOR , CHIP	220 OHM 1/10W
R114	HRJ10DJ431T	RESISTOR , CHIP	430 OHM 1/10W
R116	HRJ10DJ102T	RESISTOR , CHIP	1K OHM 1/10W
R117~R119	HRJ10DJ100T	RESISTOR , CHIP	10 OHM 1/10W
R120	HRJ10DJ472T	RESISTOR , CHIP	4K7 OHM 1/10W
R121, R127	HRJ10DJ473T	RESISTOR , CHIP	47K OHM 1/10W
R123~R126	HRJ10DJ100T	RESISTOR , CHIP	10 OHM 1/10W
R128~R135	HRJ10DJ330T	RESISTOR , CHIP	33 OHM 1/10W
R136~R147	HRJ10DJ100T	RESISTOR , CHIP	10 OHM 1/10W
R148~R153	HRJ10DJ330T	RESISTOR , CHIP	33 OHM 1/10W
R154~R160	HRJ10DJ473T	RESISTOR , CHIP	47K OHM 1/10W
R162~R169	HRJ10DJ473T	RESISTOR , CHIP	47K OHM 1/10W
R170	HRJ10DJ470T	RESISTOR , CHIP	47 OHM 1/10W
R171~R186	HRJ10DJ330T	RESISTOR , CHIP	33 OHM 1/10W
R187~R189	HRJ10DJ470T	RESISTOR , CHIP	47 OHM 1/10W
R190~R192	HRJ10DJ330T	RESISTOR , CHIP	33 OHM 1/10W
R193~R196	HRJ10DJ470T	RESISTOR , CHIP	47 OHM 1/10W
R197, R198	HRJ10DJ472T	RESISTOR , CHIP	4K7 OHM 1/10W
R200, R213	HRJ10DJ472T	RESISTOR , CHIP	4K7 OHM 1/10W
R201	HRJ10DJ330T	RESISTOR , CHIP	33 OHM 1/10W
R203	HRJ10DJ100T	RESISTOR , CHIP	10 OHM 1/10W
R208, R214	HRJ10DJ0R0T	RESISTOR , CHIP	JUMPER
R217, R218	HRJ10DJ101T	RESISTOR , CHIP	100 OHM 1/10W
R219, R220	HRJ10DJ152T	RESISTOR , CHIP	1K5 OHM 1/10W
R222, R223	HRJ10DJ101T	RESISTOR , CHIP	100 OHM 1/10W
R225, R226	HRJ10DJ101T	RESISTOR , CHIP	100 OHM 1/10W
R228	HRJ10DJ472T	RESISTOR , CHIP	4K7 OHM 1/10W
R229	HRJ10DF402T	RESISTOR , CHIP	4K OHM 1/10W
R230, R231	HRJ10DJ330T	RESISTOR , CHIP	33 OHM 1/10W
R248, R249	HRJ10DJ102T	RESISTOR , CHIP	1K OHM 1/10W
R250	HRJ10DJ331T	RESISTOR , CHIP	330 OHM 1/10W
R251, R252	HRJ10DJ472T	RESISTOR , CHIP	4K7 OHM 1/10W
R260	HRJ10DJ0R0T	RESISTOR , CHIP	JUMPER
R261~R264	HRJ10DJ473T	RESISTOR , CHIP	47K OHM 1/10W
R267	HRJ10DJ750T	RESISTOR , CHIP	75 OHM 1/10W
R268	HRJ10DJ820T	RESISTOR , CHIP	82 OHM 1/10W
R269~R272	HRJ10DJ750T	RESISTOR , CHIP	75 OHM 1/10W
R273	HRJ10DJ102T	RESISTOR , CHIP	1K OHM 1/10W
X101	HOX27000E180S	CRYSTAL , CHIP(27MHZ,SMD)	HC-49/US
	CJDL70CCC	MECHANISM ASS'Y	
	HJDRL-A700HD3	1 DVD MECHANISM (HD3 P/U)	RL-A700(HD3)
	HDMKD1245pFS2	MOTOR , FAN	
	HLZ9Z004Z	FERRITE CORE	6*5*34

LOAD NO.	PART NO.	DESCRIPTION	SPECIFICATION
BN12	CWC1B4A23A300B	CABLE, CARD	29X7.7X19
	CWE4202050AS	WIRE ASS'Y	
	CWE4202100AR	WIRE ASS'Y	
	CWZDR700BN47	WIRE ASS'Y	
	CWZHTS5000BN12	CABLE,ATAPI(FLATE,40P)	
	CLZ9W003Z	FERRITE , RING	
	CWC1B4A15A150B	CABLE , CARD	
	CWC1B4A17A120B	CABLE , CARD	
	CWC1B4A23A100B	CABLE , CARD	
	CWC1C4A13B200B	CABLE , CARD	
PWR1	CWC1C4A15B080B	CABLE , CARD	KST-MB014MA1-8
	CLT5V031ZE	TRANSISTORANS , MAIN (C VER.)	
TUN1	CLT5V031ZU	TRANSISTORANS , MAIN (AH VER.)	KST-MB001MA0-9
	CNVKSTMB014MA18	MODULE , TUNER (C VER.)	
	CNVMB001MA09DS	MODULE , TUNER (AH VER.)	
	CQXL70CCC	INSTRANSISTORUCTION MANUAL ASSY	
	CARTL70CCC	REMOTE UNIT	
	CQX1A797Y	MANUAL, INSTRANSISTORUCTION (C VER.)	
	CQX1A801Z	MANUAL, INSTRANSISTORUCTION (AH VER.)	
	CSA267	ANT , FM.T (LUG TYPE)	
	CSA3A011Z	AM LOOP ANTENNA ASS'Y	LEADWIRE TYPE
	HABAAAM1.5V	BATTERY	
	KLR001	ADAPTOR , MATCHING(300-75)	NTSC , UL

SERVICE MANUAL

L 70

**AV SURROUND
SOUND DVD RECEIVER**

© NAD 2002

**NAD ELECTRONICS LTD
TORONTO**