

M17

AV Surround sound Preampfier

M17

AV Surround sound Preampfier

SERVICE MANUAL



CONTENTS

DESCRIPTION	PAGE
SPECIFICATIONS -----	3
WIRING DIAGRAM -----	4-5
BLOCK DIAGRAM -----	6-12
SPECIAL FUNCTION -----	13
DETAILS & WAVEFORMS ON SYSTEM & TEST & DEBUGGING -----	14-15
PCB LAYOUT -----	16-39
SCHEMATIC DIAGRAM -----	40-73
ELECTRICAL PARTS LIST -----	74-94
EXPLODED VIEW -----	95
EXPLODED VIEW PARTS LIST -----	96
PACKING ACCESSORY SECTION -----	97

SPECIFICATIONS

CONNECTIONS	M17
HDMI	Up to 1080p
Optical	3 Vpp
Coaxial	0.5 Vpp
Ethernet	RJ45 10/100 Ethernet Tx
LINE LEVEL INPUT	
Input Impedance (R and C)	56kΩ + 220pF
Input Sensitivity	40mV (ref. 500mV out)
Maximum Input Signal	>8Vrms
Signal/Noise Ratio, A-weighted	>90dB (ref. 500mV in, 500mV out, volume set to unity gain) >80dB (ref. 2V out, volume maximum)
Channel Separation	>70dB (ref. 1kHz / 10kHz)
Frequency Response	±0.3dB (ref. 20Hz - 20kHz, Tone Active) ±0.3dB (ref. 20Hz - 20kHz, Tone Defeat)
Frequency Response (subwoofer out)	10 - 200Hz (ref. -3dB)
OUTPUT	
XLR	>2Vrms
Maximum output level	>8Vrms into 600Ω
THD (CCIF IMD, DIM 100)	<0.005% (ref. 20Hz - 20kHz, 2V out)
Tone Controls	Treble ±10dB at 10kHz (ref. 2V in, 2V out) Bass ±10dB at 100kHz (ref. 2V in, 2V out)
GENERAL	
Standby power	<0.5W
Unit Dimension (WxHxD) - Gross*	435 x 156 x 386mm 17 1/8 x 6 3/16 x 15 1/4 inches**
Net weight	10.9kg (24lb)
Shipping weight	17.5kg (38.6lb)

* Gross dimensions include feet, extended buttons and rear panel terminals.

** Non-metric measurements are approximate. NAD Electronics will not assume any liability for errors being made by retailers, custom installers, cabinet makers, or other end users based on information contained in this document.

Note: Installers should allow a minimum clearance of 55mm for wire/cable management.

WIRING DIAGRAM

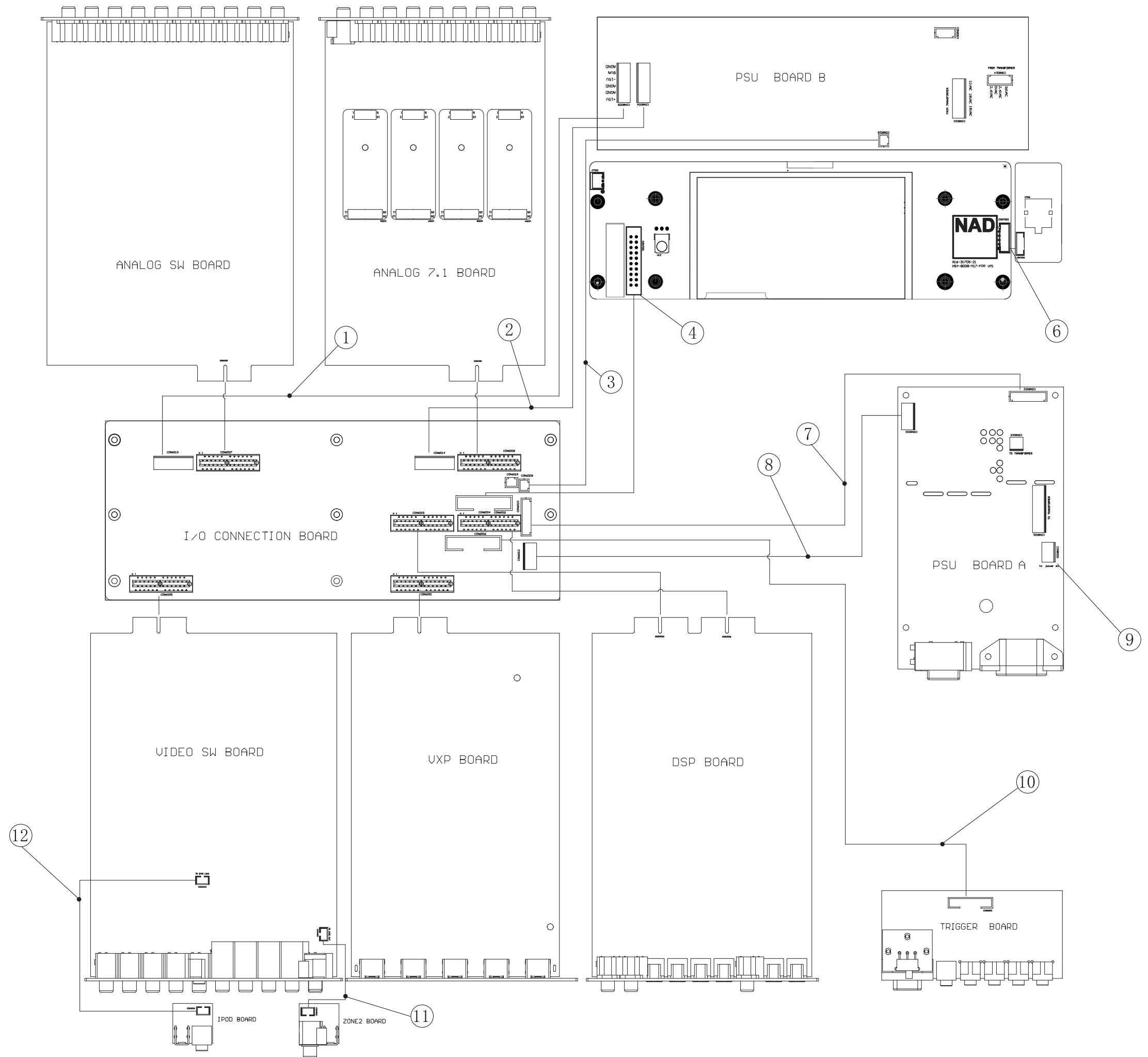

WIRING DIAGRAM PARTS LIST

ITEM	Part Number	Description	Remark
1	14-11506-01	CABLE L=120mm	PSUB to connect board
2	14-11506-00	CABLE L=240mm	PSUB to connect board
3	14-11502-02	CABLE L=120mm	PSUB to connect board
4	14-32220-11	CABLE	CON7001
6	14-11506-02	CABLE L=100mm	FPP to Encoder board
7	14-11508-00	CABLE L=250mm	PSUA to connect board
8	14-11504-00	CABLE ,L=180mm	PSUA to connect board
9	14-11502-01	CABLE ,L=100mm	PSUA to power switch
10	14-11520-00	CABLE L=380mm	CON9000,CON6006
11	14-11503-00	CABLE L=100mm	con4001 to con4002
12	14-11503-00	CABLE L=100mm	con4003 to con4004

BLOCK DIAGRAM

M17 Audio 7.1 Board_1

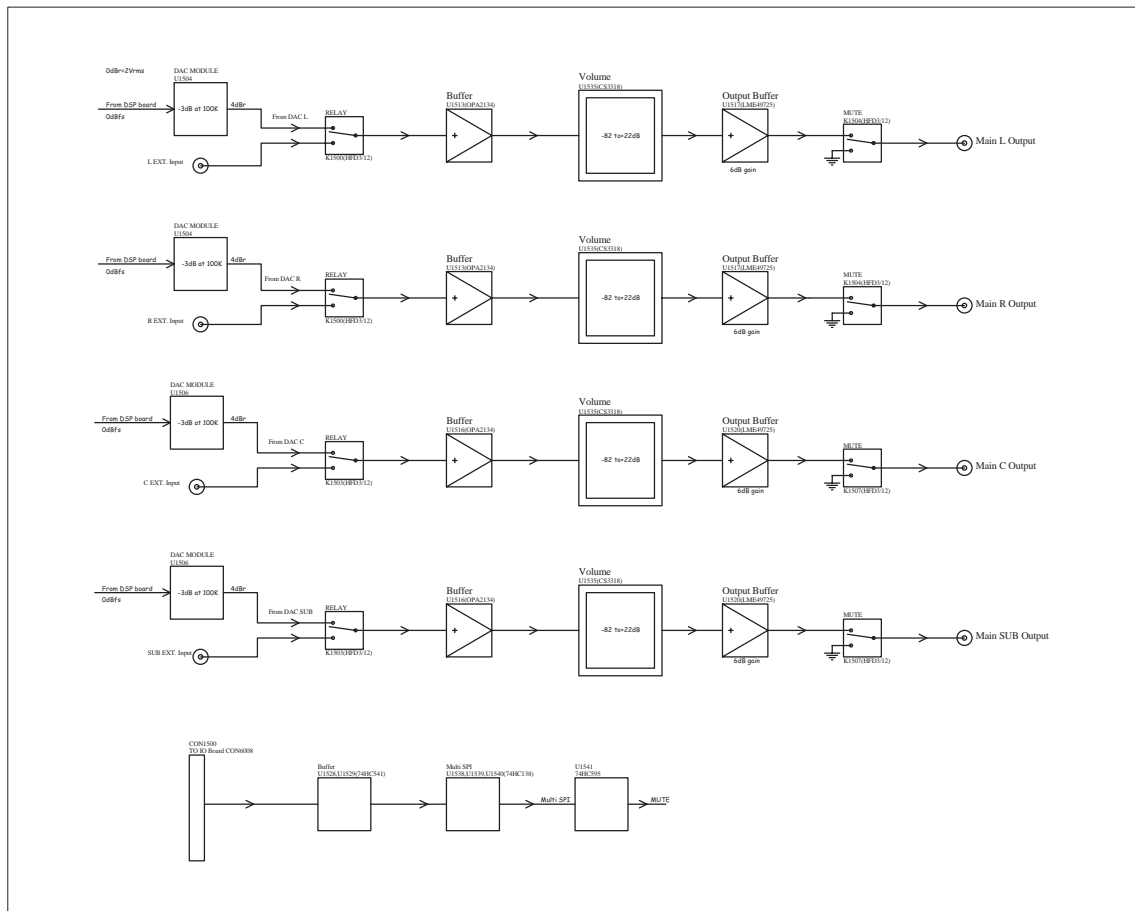

M17 Audio 7.1 Board_2

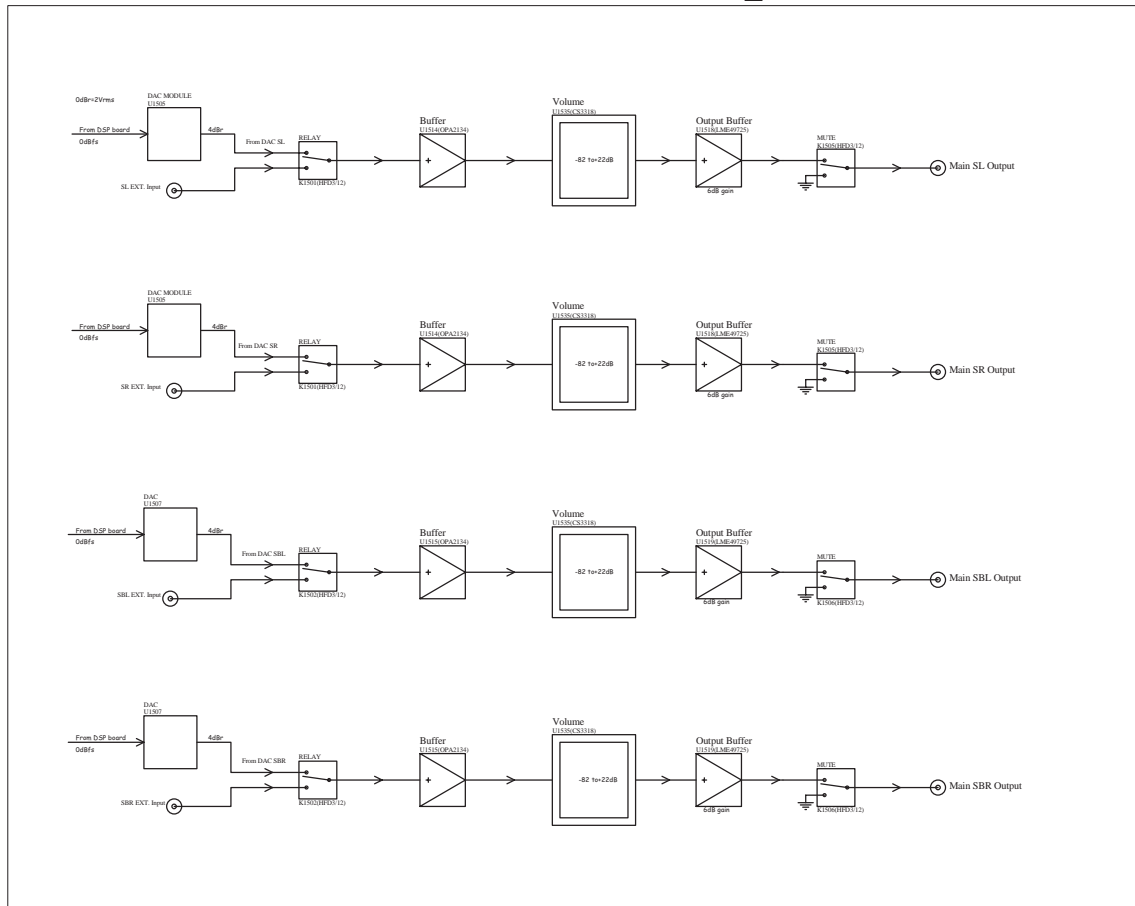

M17 Audio_analog Board

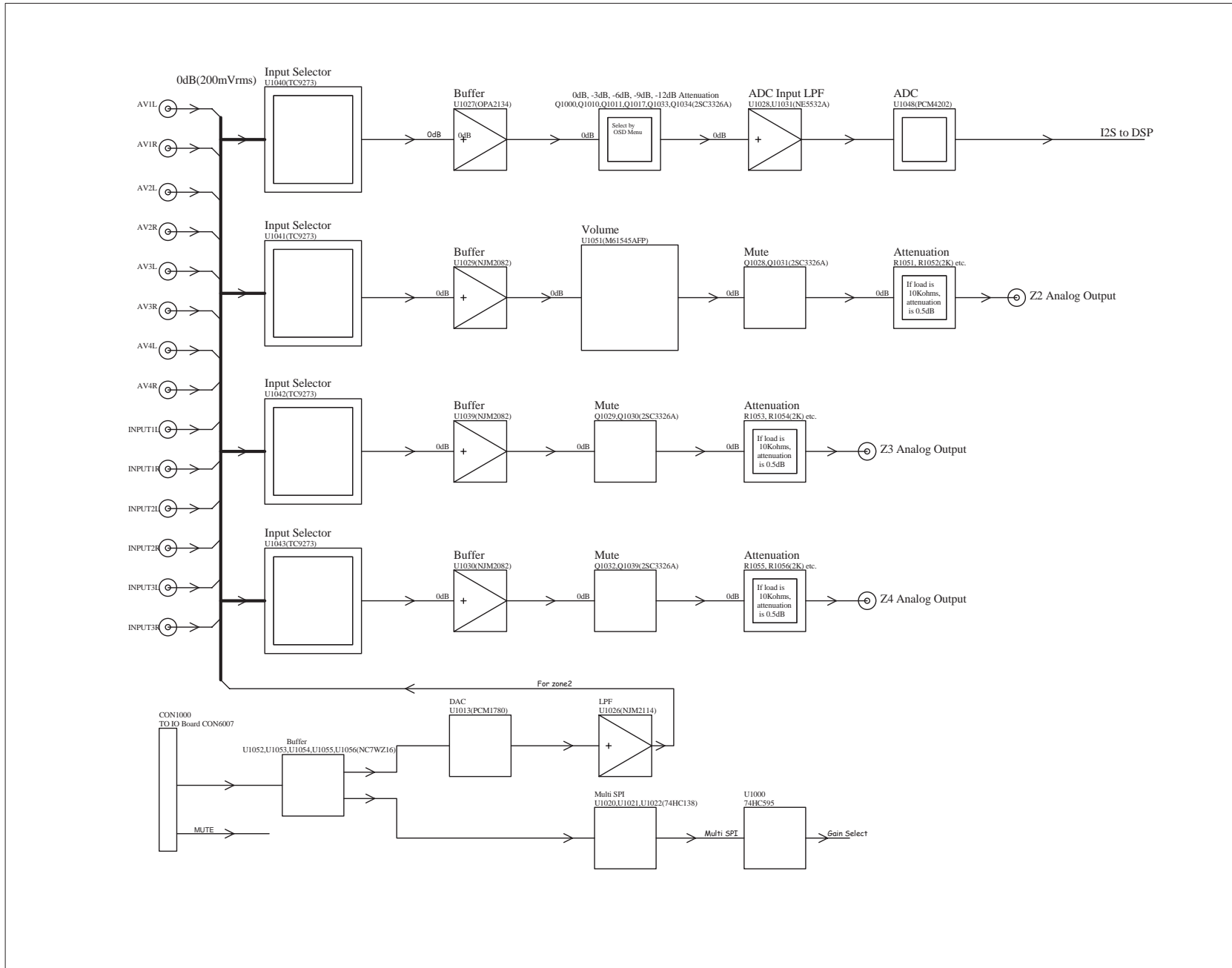

M1+ DSP BOARD

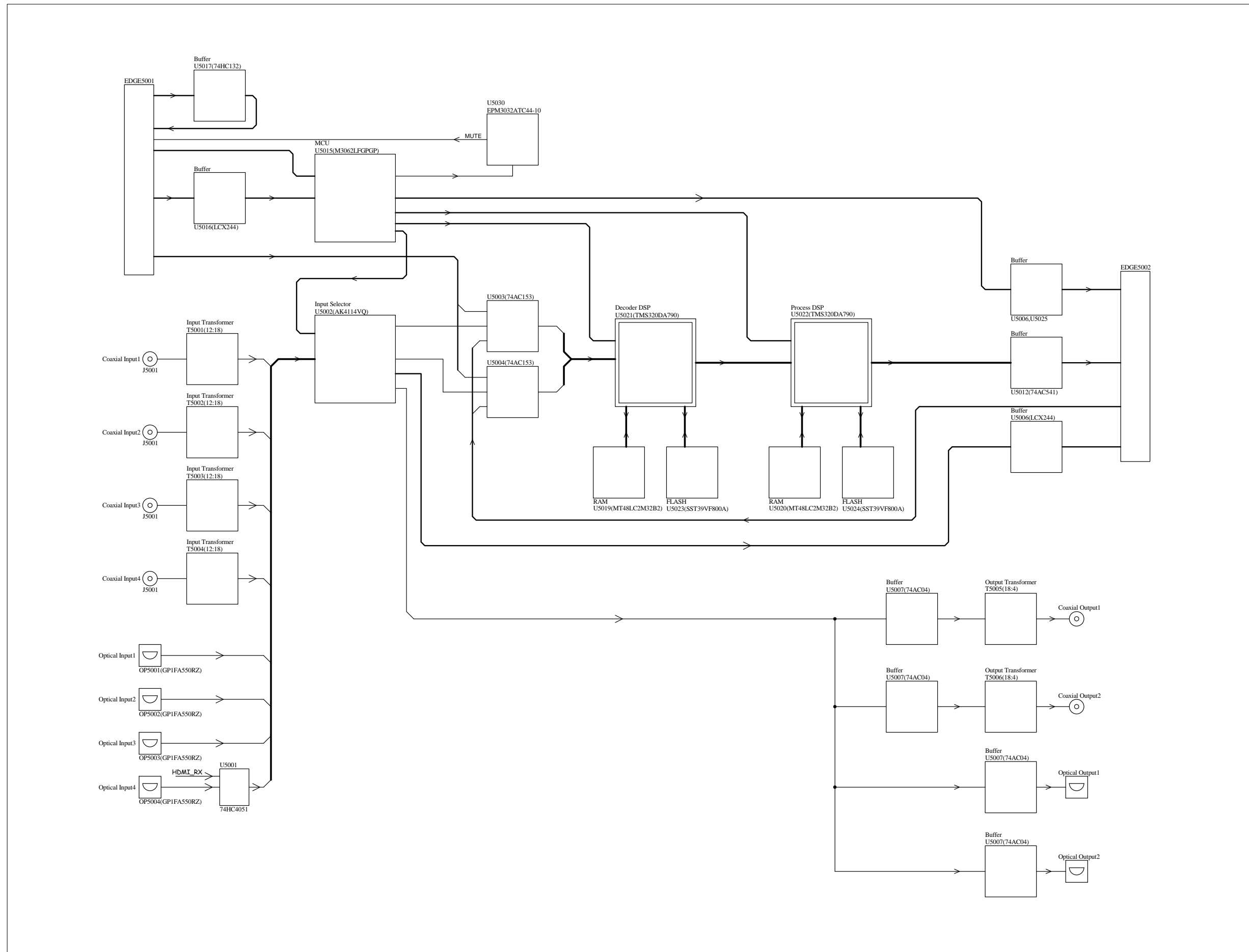

M17 FPP BOARD

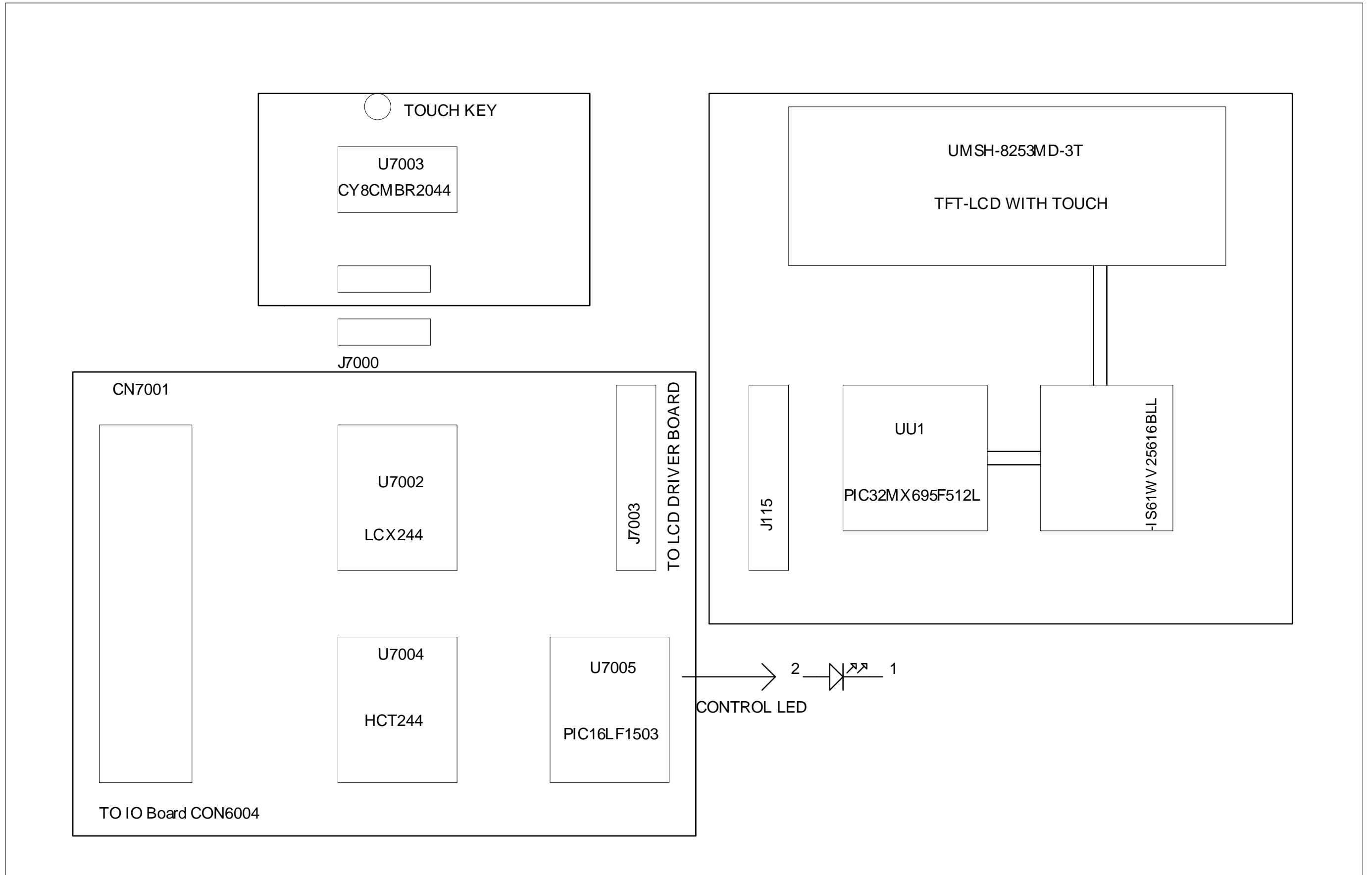

M1+ I/O BOARD

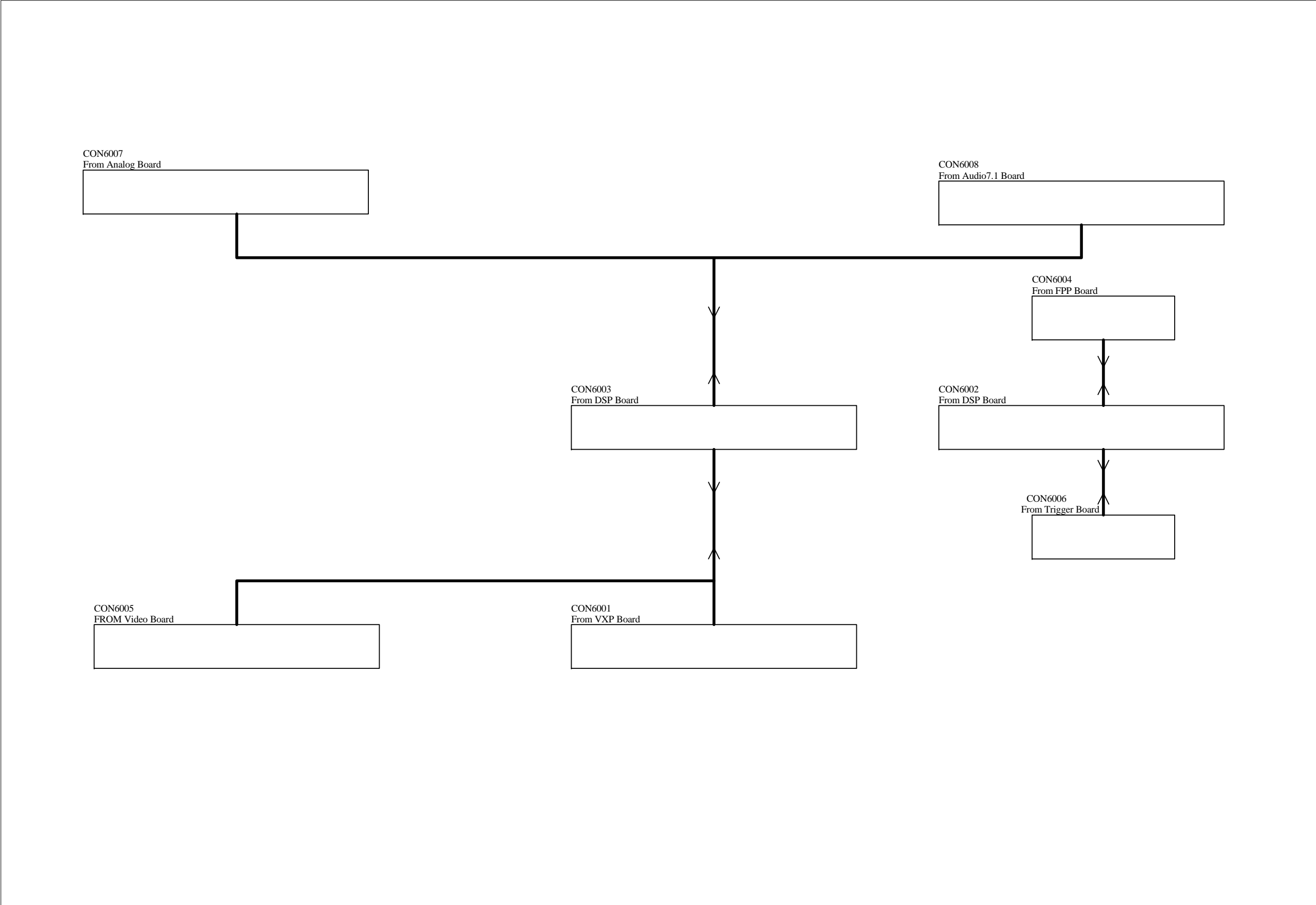

M1+ PSU BOARD

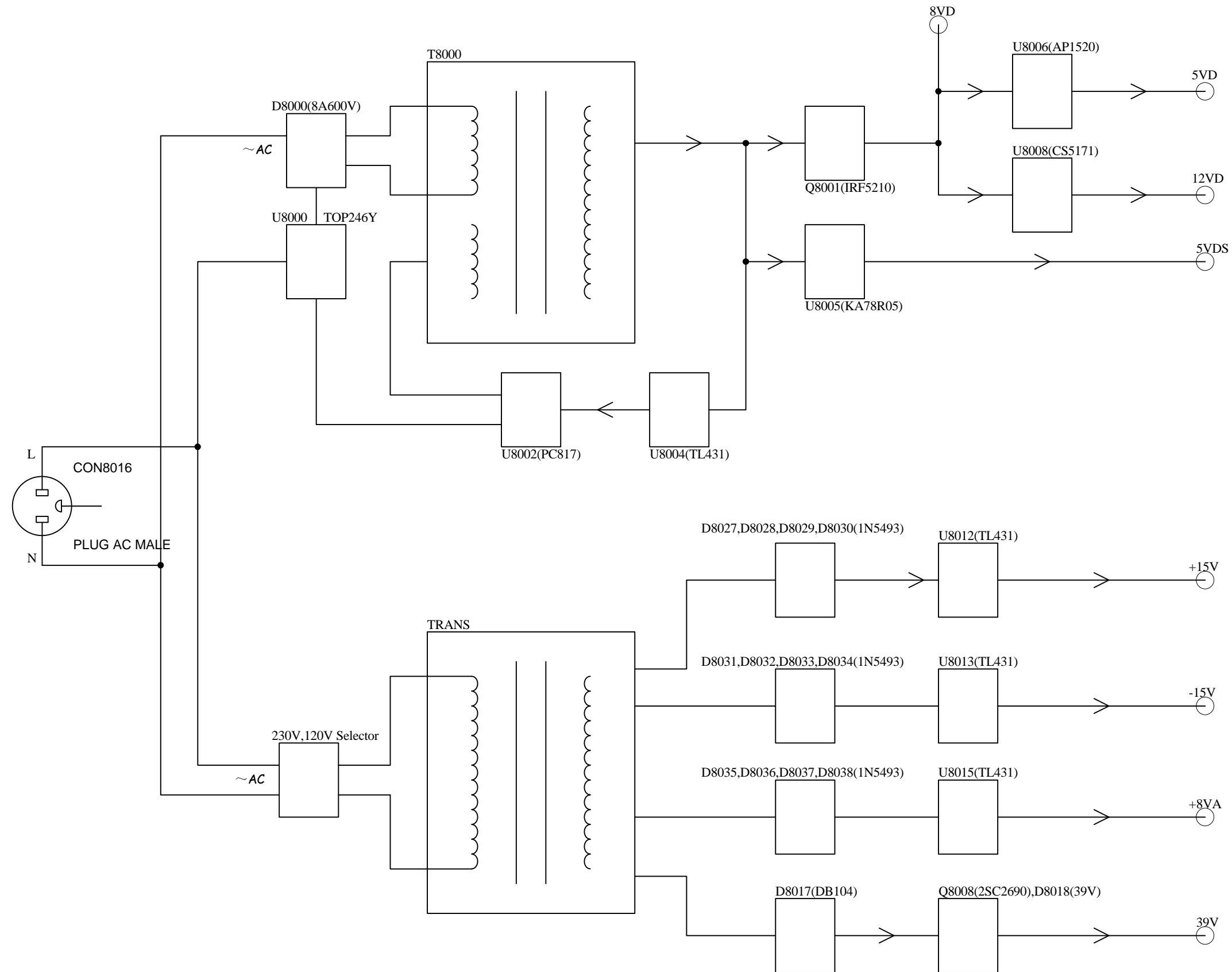

M17 Trigger Board

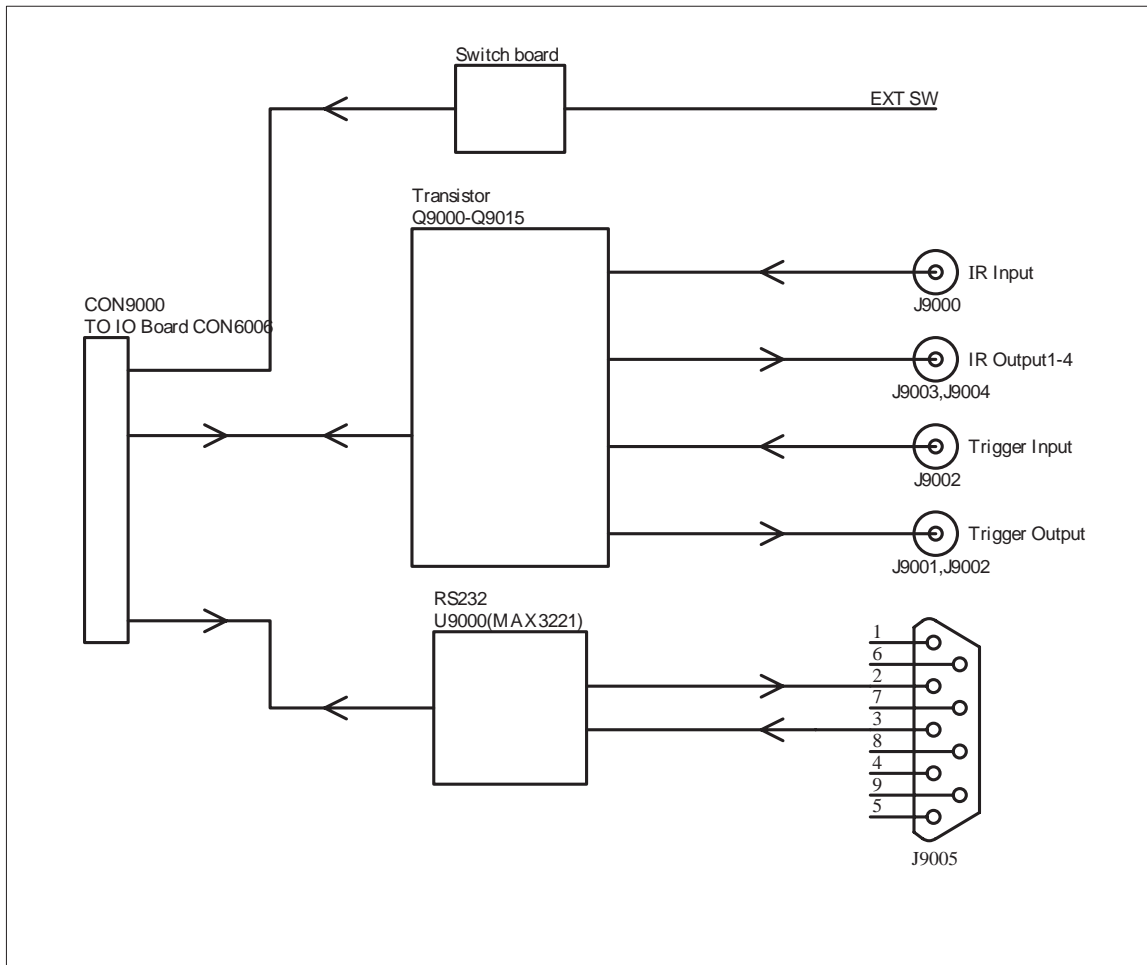

M17 Video Board

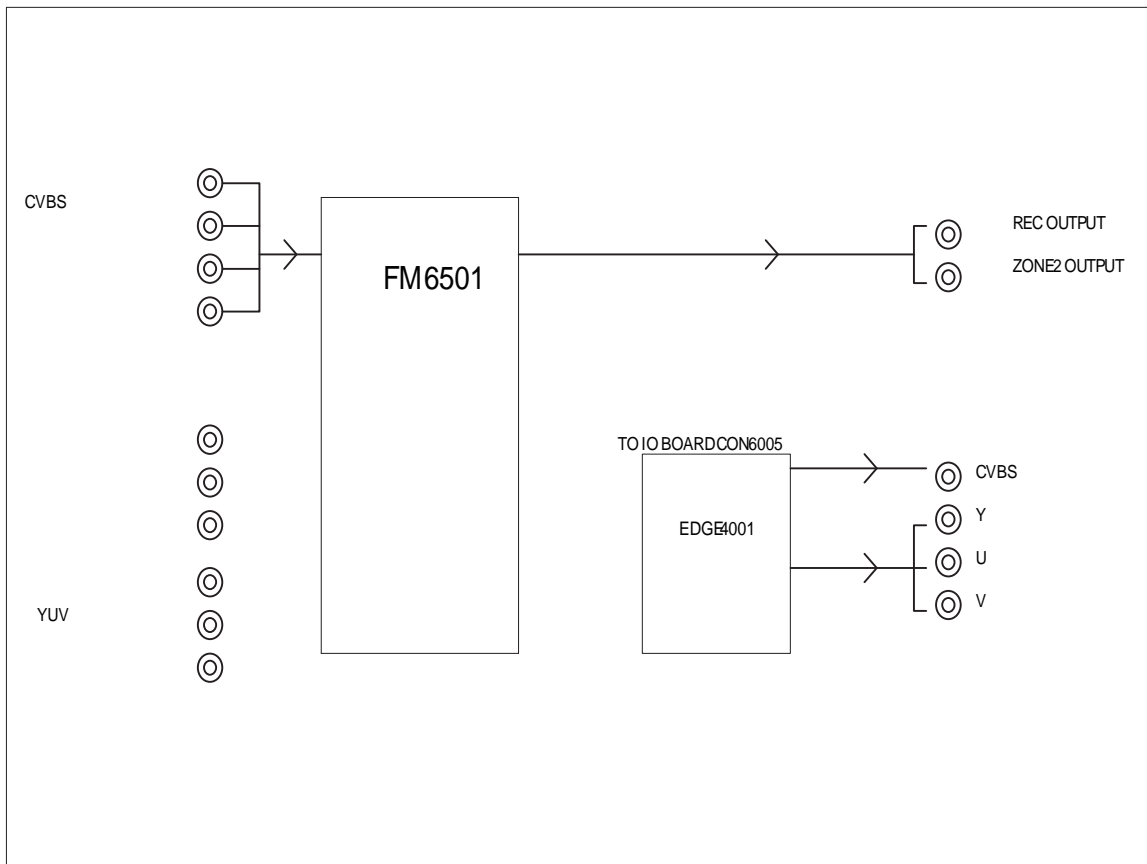

DETAILS & WAVEFORMS ON SYSTEM & TEST & DEBUGGING

Video Wave

(1) Test the signal of S MONITOR OUT by the wave of oscilloscope. Video source is 100% color Bar

(a) Target, Y-signal

Point : S_video Y
 Adjustment Value : $700 \pm 70\text{mV}$
 Waveform

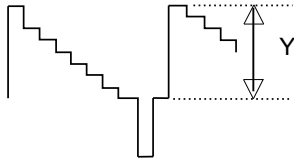

Y-signal of S MONITOR OUT

(b) Target, C-signal

Point : S_video C
 Test Value : $286 \pm 28\text{mV}$
 Waveform

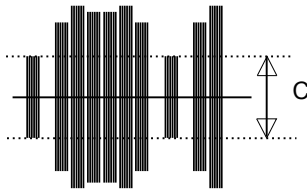

C-signal of S-MONITOR

(c) Target, PR/CR-signal

Point : Component PR/CR
 Test Value : $*700 \pm 70\text{mV}$
 Waveform

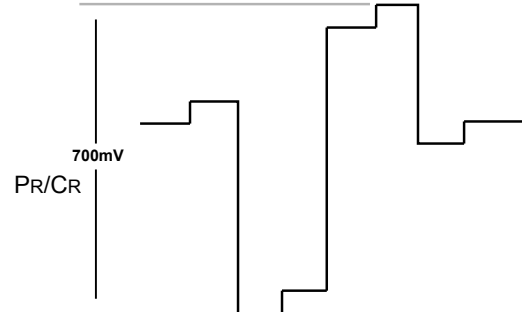

PR/CR-signal COMPONENT OUT

(2) Adjust the signal of COMPONENT OUT by the wave of oscilloscope.

(a) Target, Y-signal

Point : Component Y
 Test Value : $700 \pm 70\text{mV}$
 Waveform

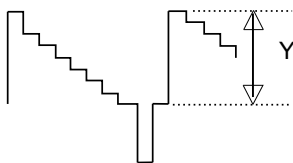

Y-signal COMPONENT OUT

(b) Target, PB/CB-signal

Point : Component PB/CB
 Test Value : $*700 \pm 70\text{mV}$
 Waveform

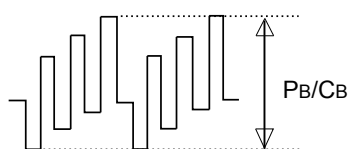

PB/CB-signal COMPONENT OUT

AUDIO OUTPUT TO AUDIO DAC

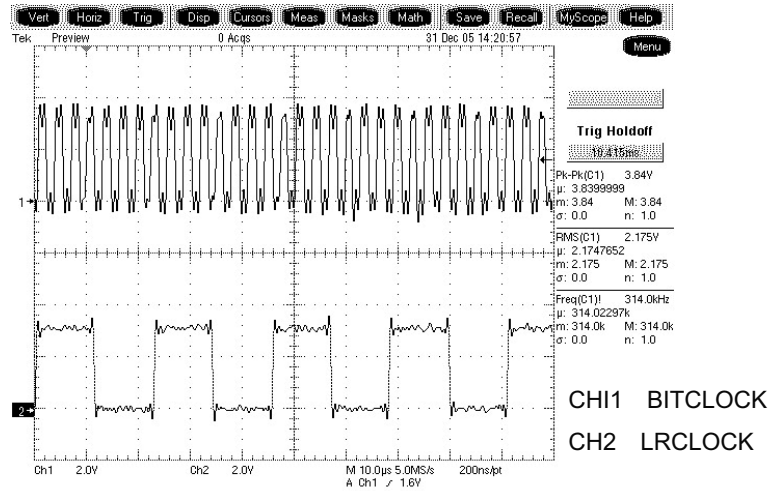

AUDIO OUTPUT (1KHZ 0DB)

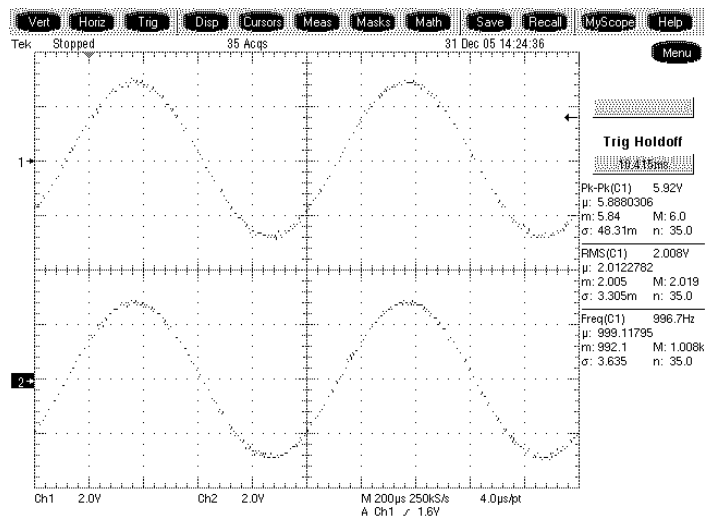

PCB LAYOUT

DSP BOARD - COPPER SIDE

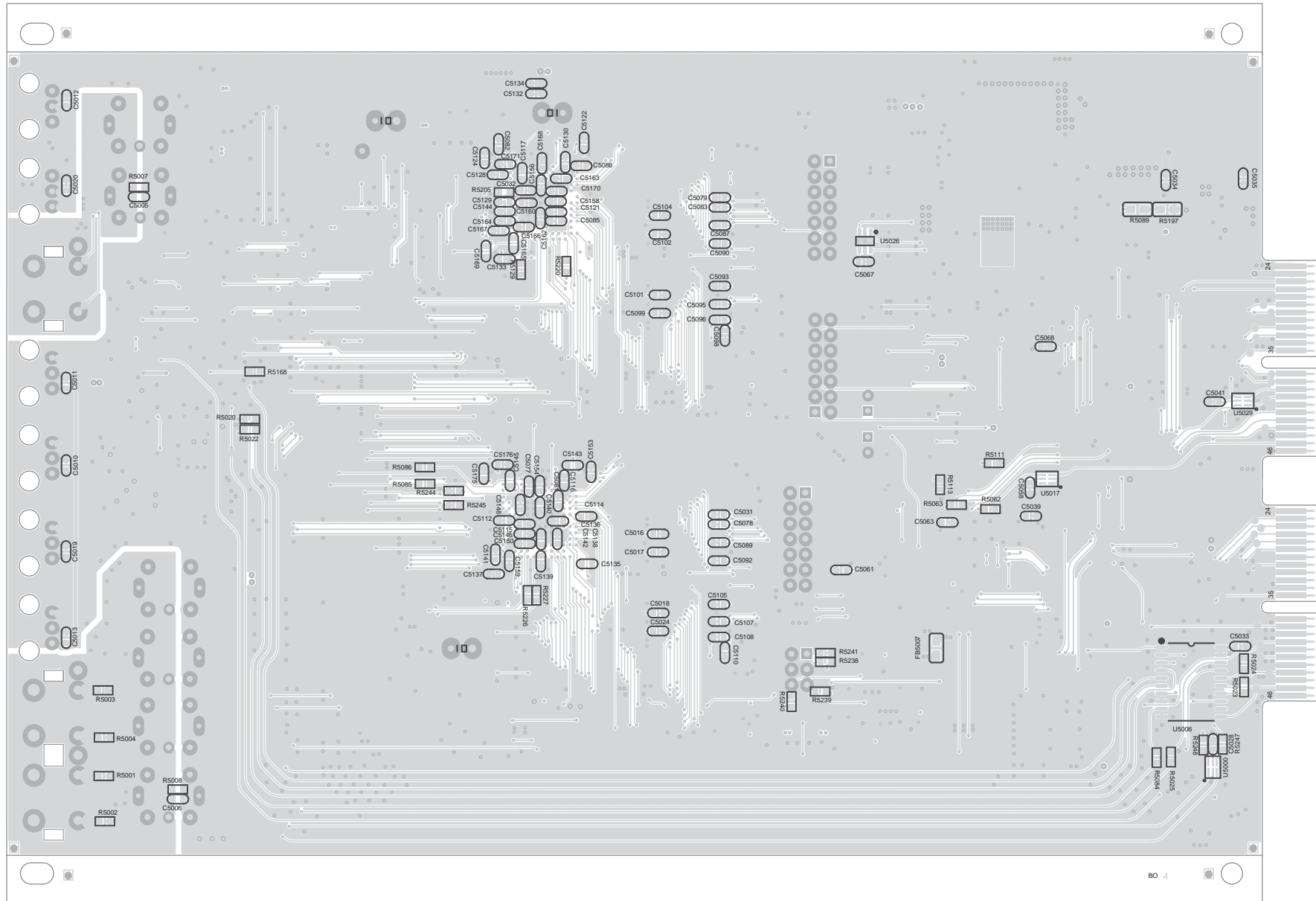

DSP BOARD - COMPONENT SIDE

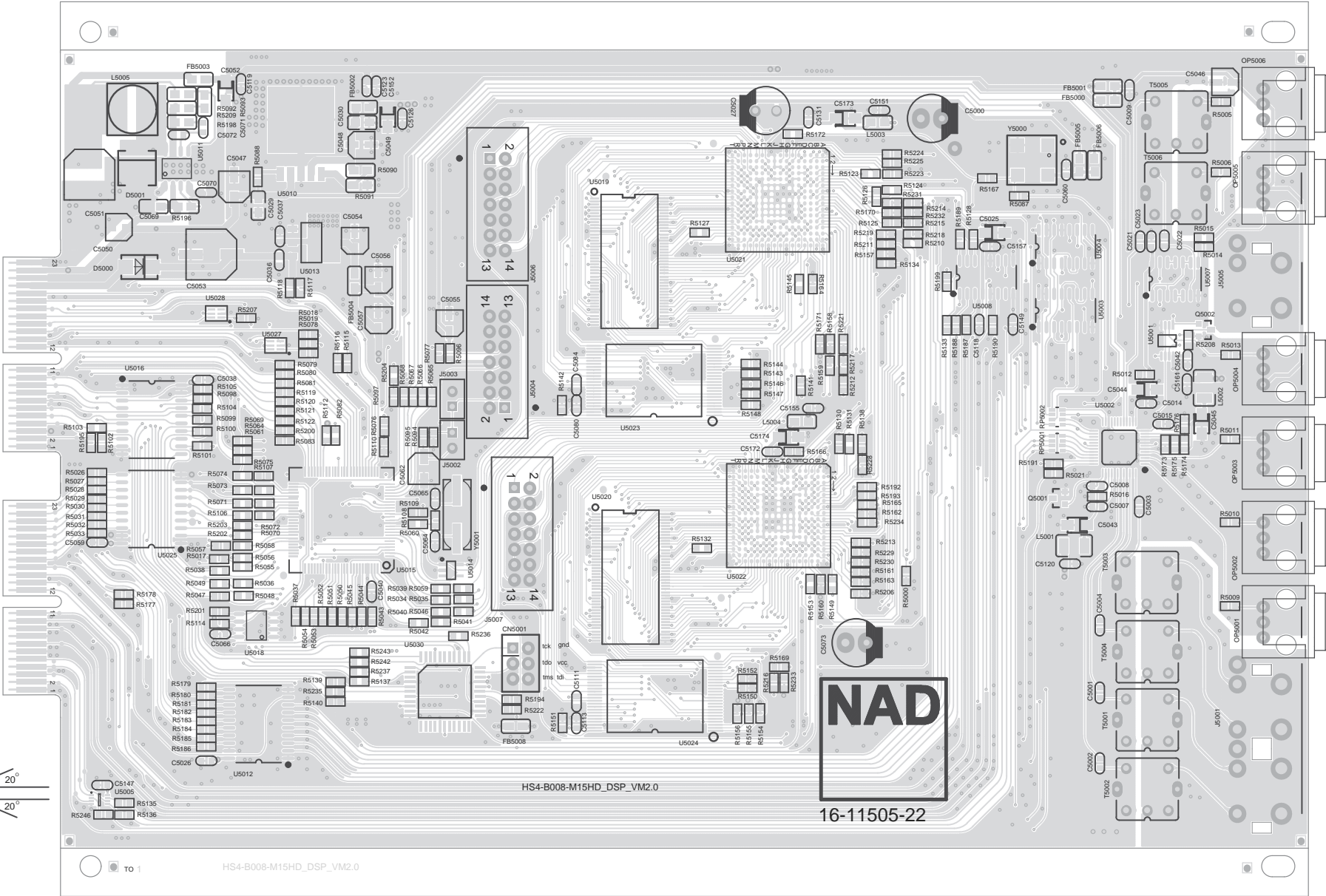

KEYBOARD - COPPER SIDE

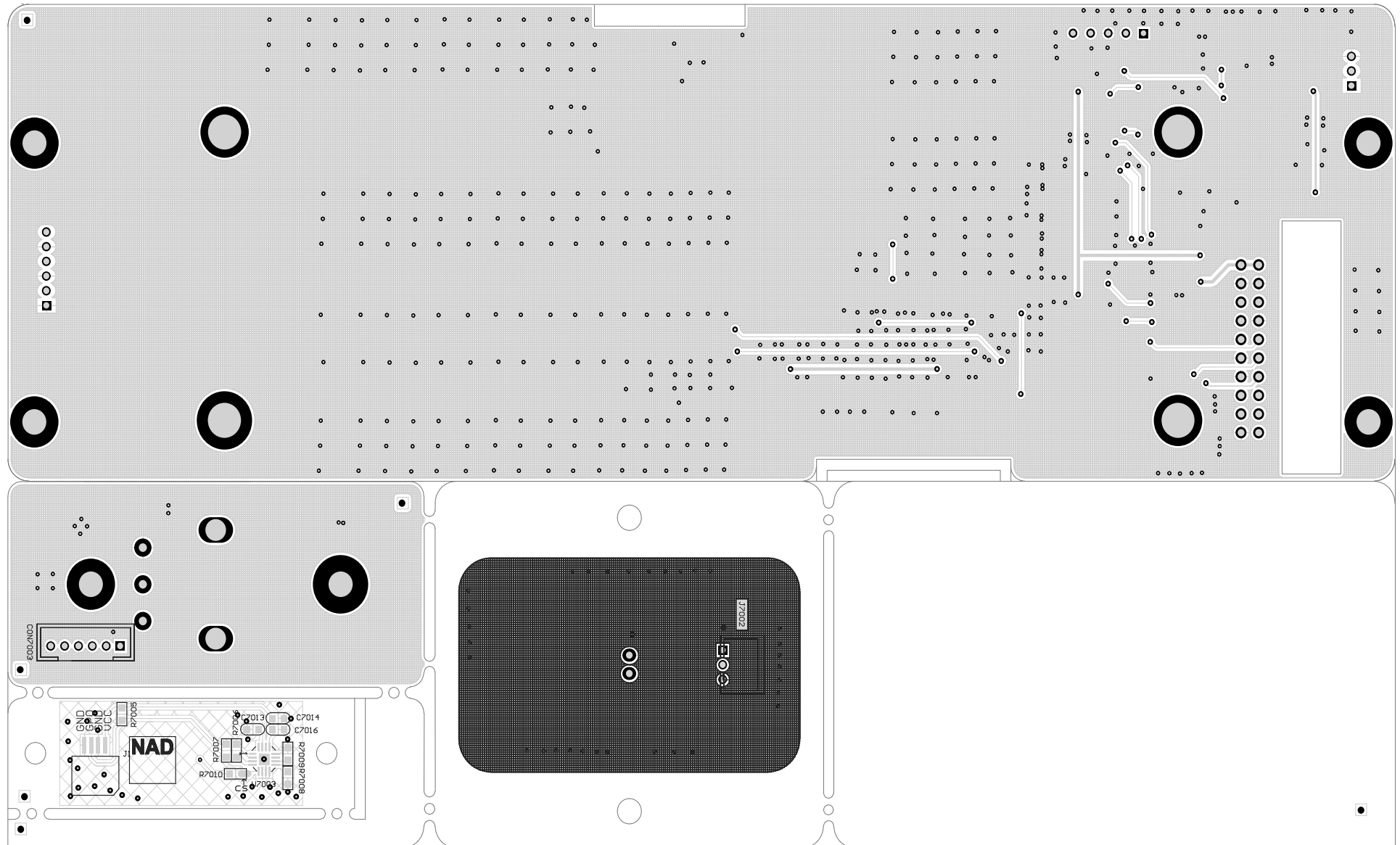

KEYBOARD - COMPONENT SIDE

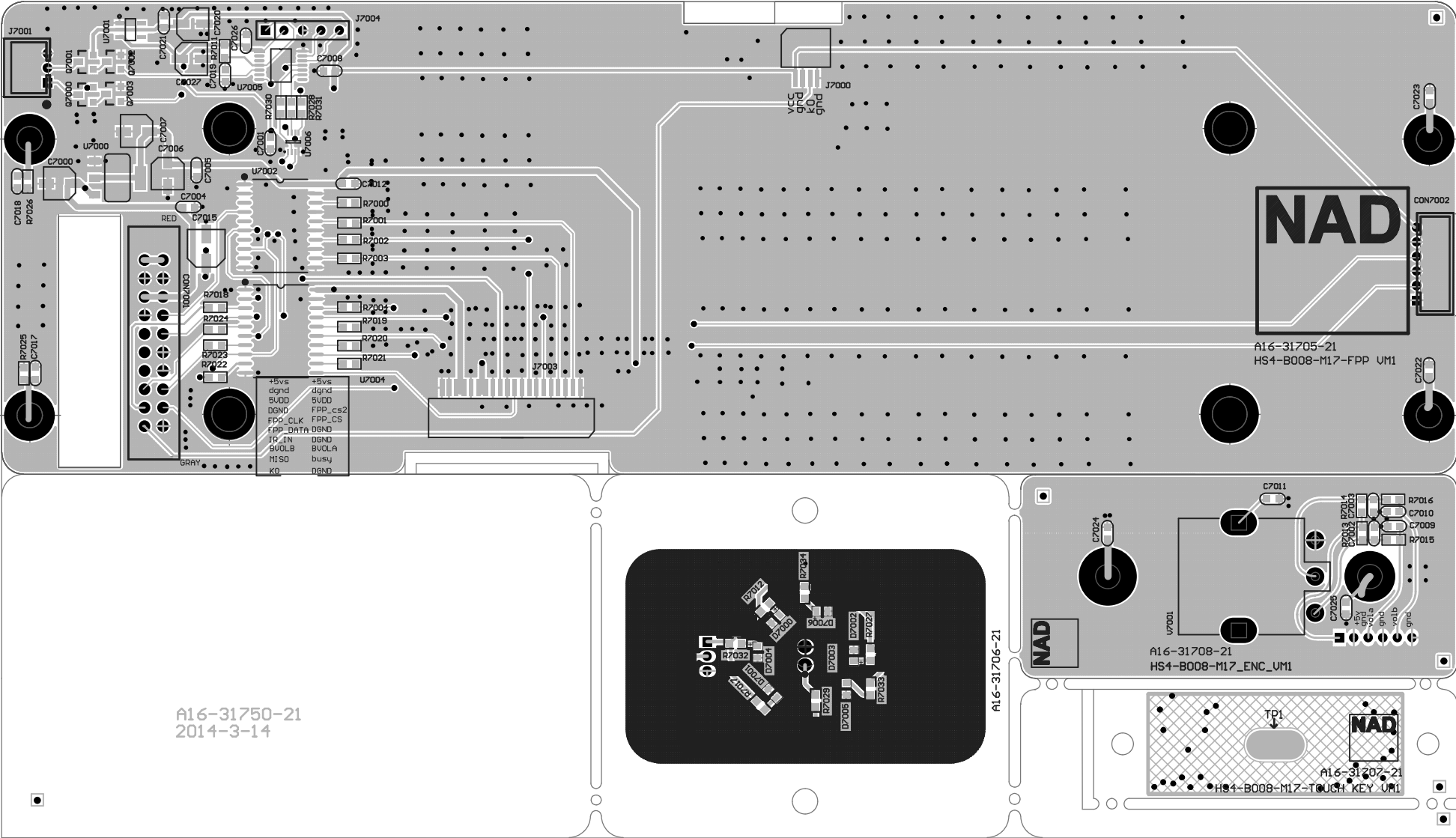

VIDEO BOARD - COPPER SIDE

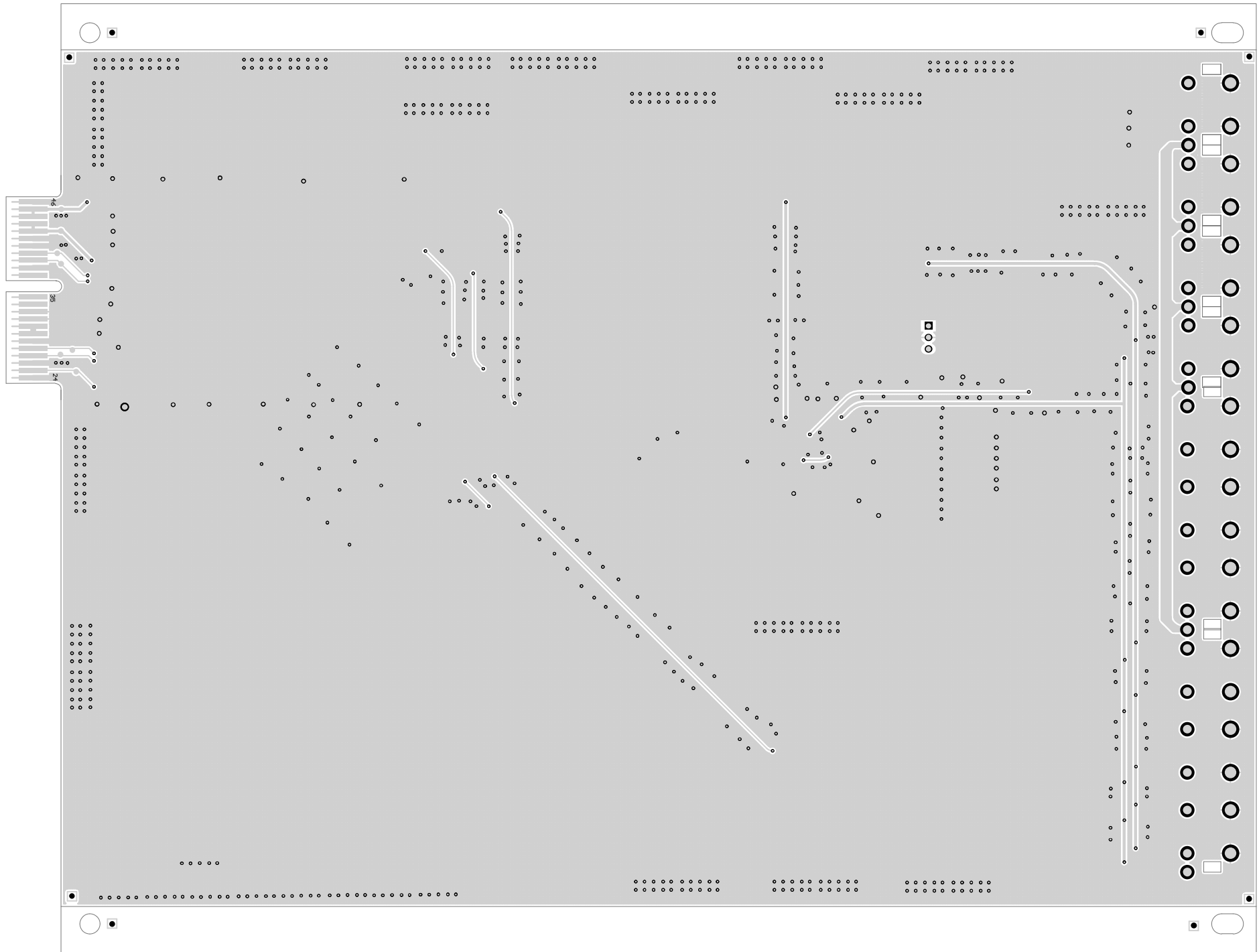

AUDIO 7_1 BOARD - COPPER SIDE

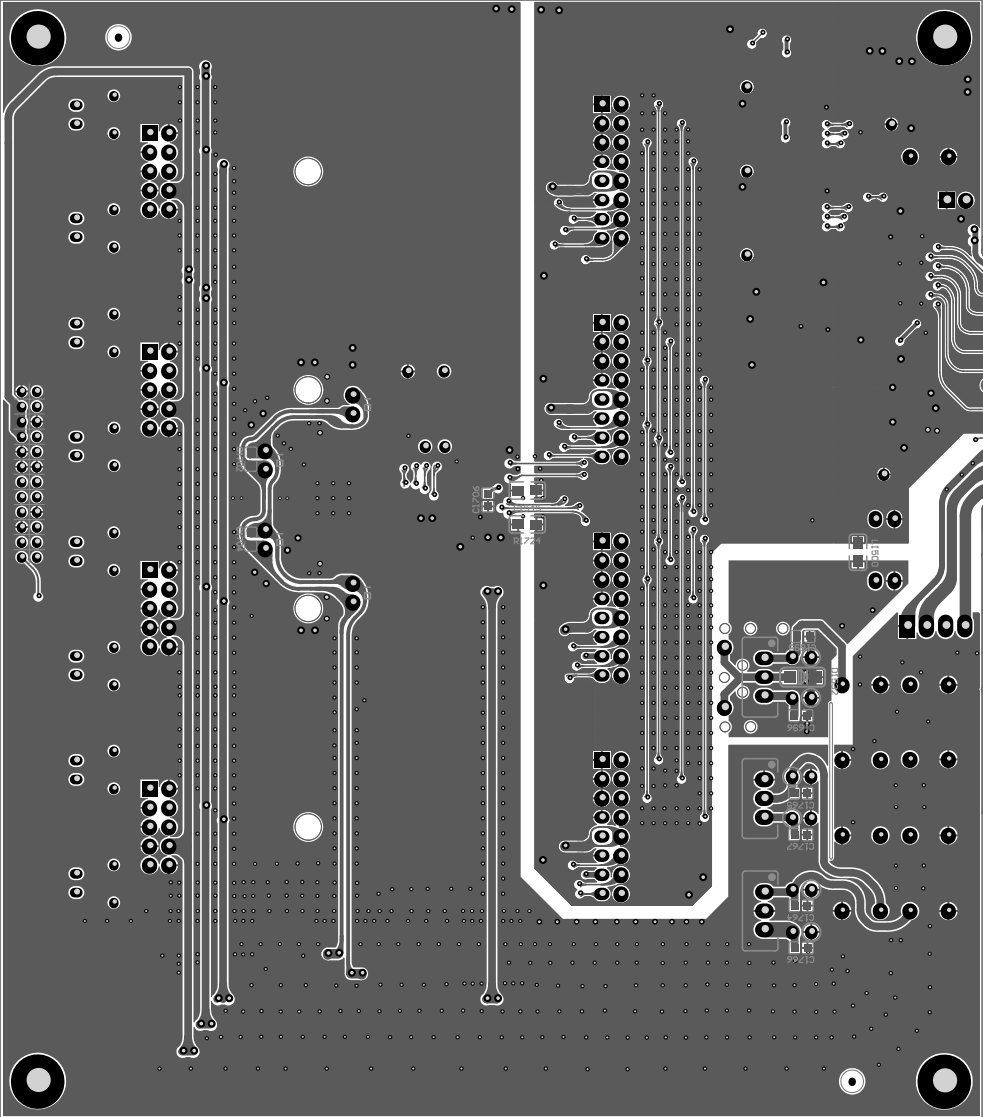

AUDIO 7_1 BOARD - COMPONENT SIDE

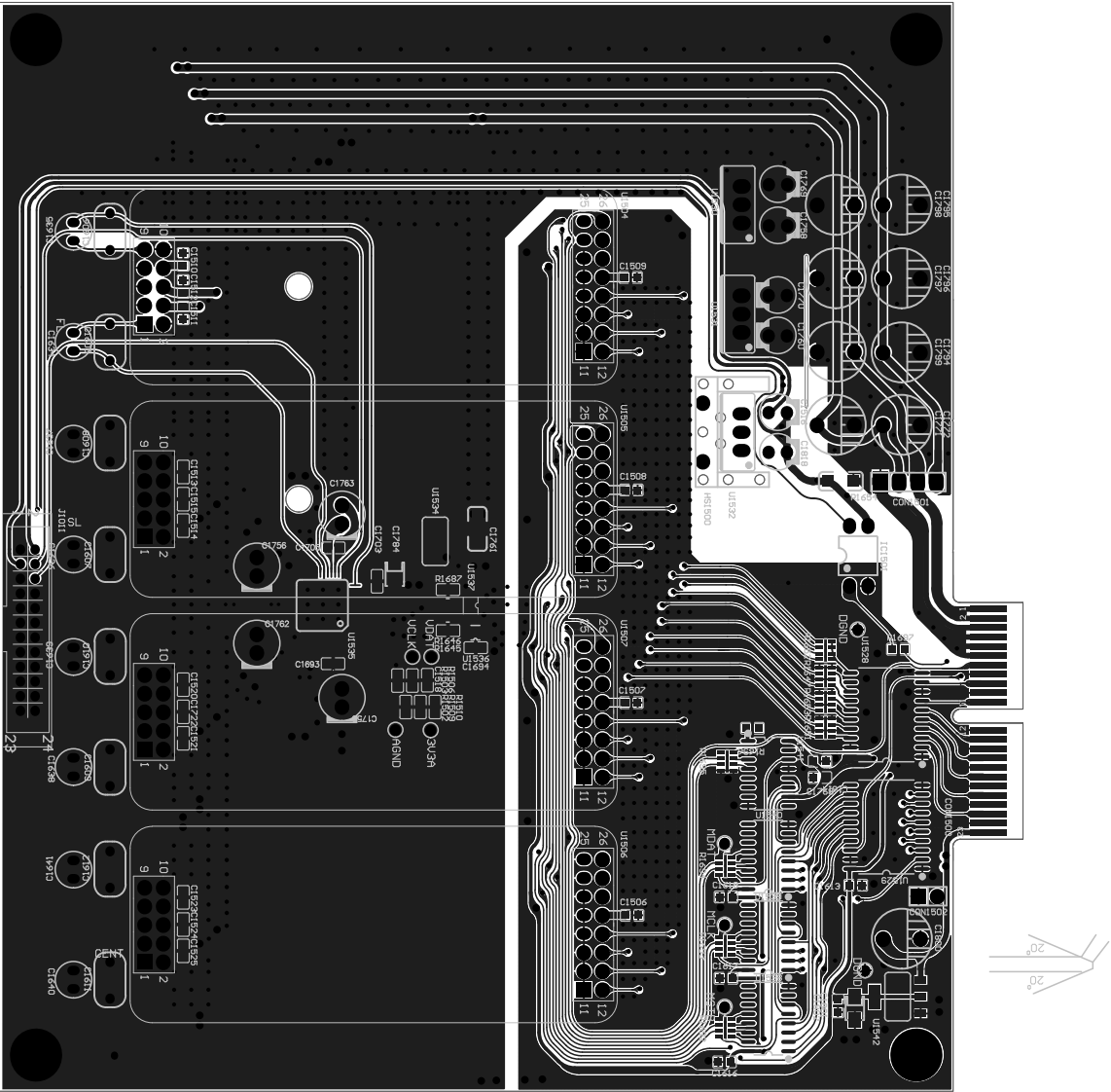

DAC BOARD - COPPER SIDE

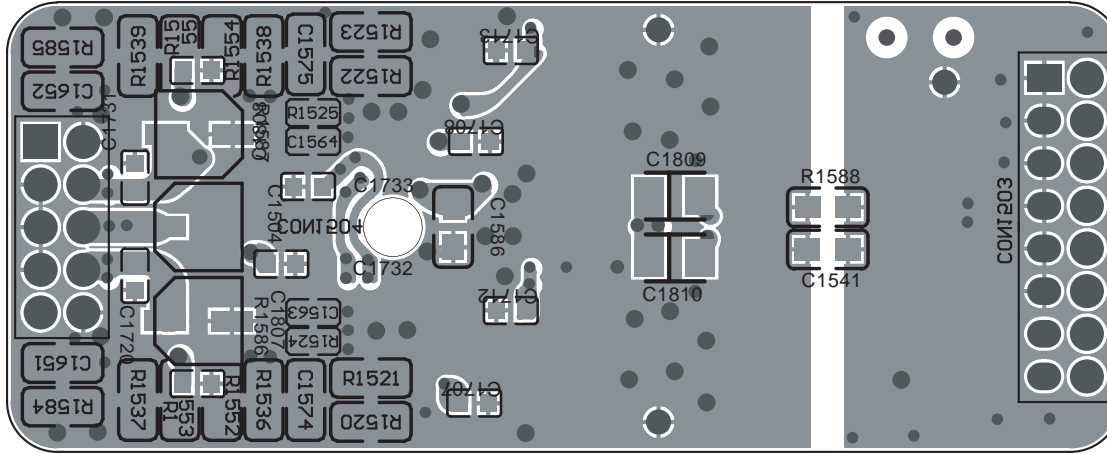

DAC BOARD - COMPONENT SIDE

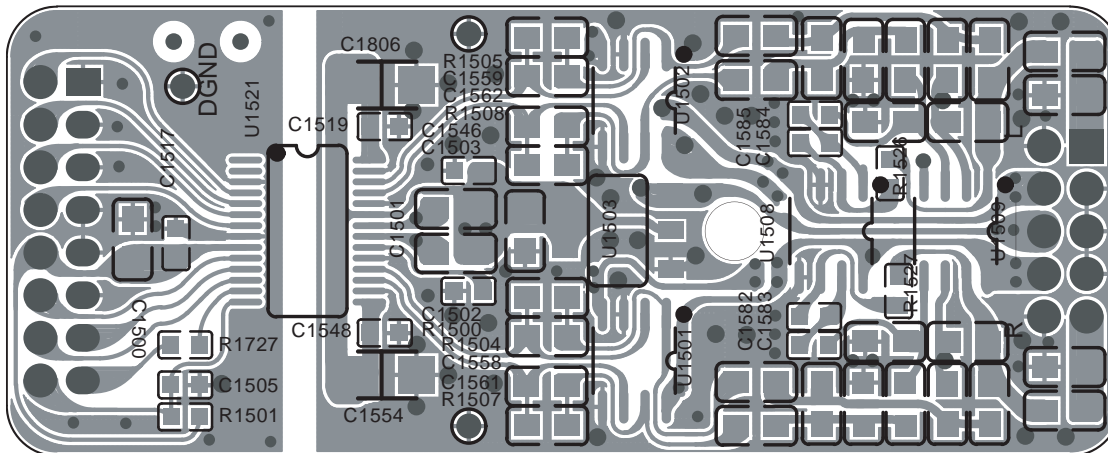

AUDIO INTERFACE BOARD - COPPER SIDE

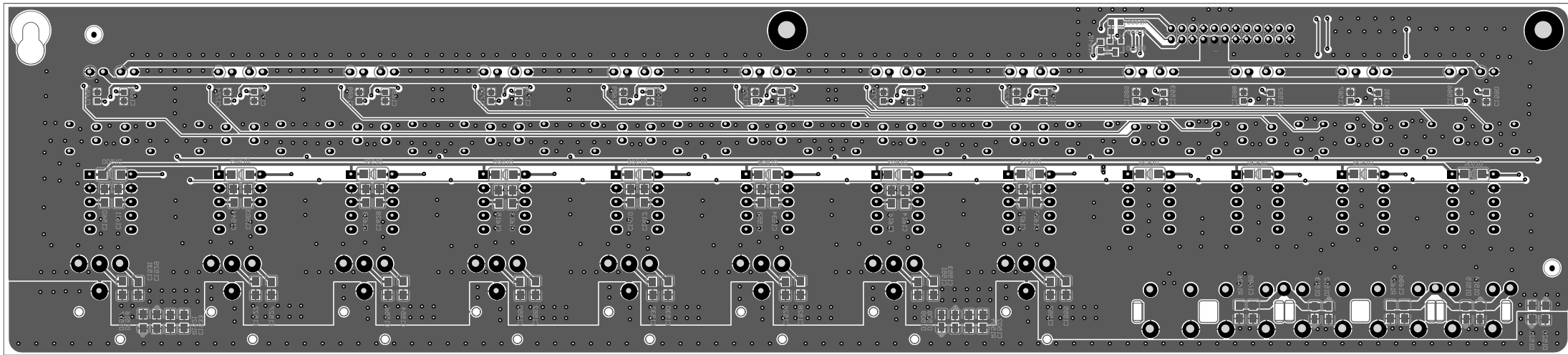

AUDIO INTERFACE BOARD - COMPONENT SIDE

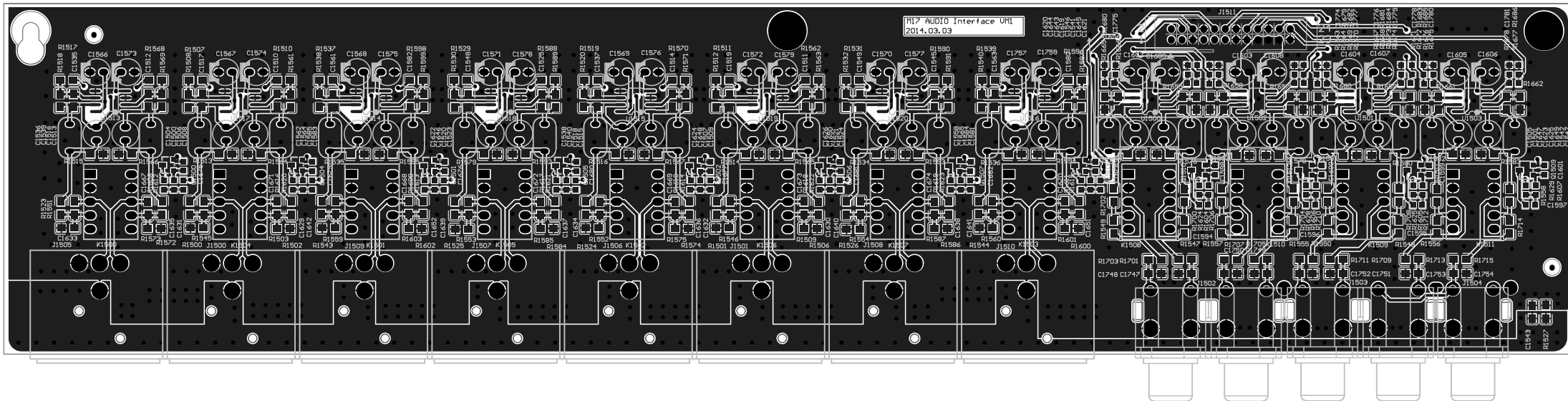

I/O BOARD - CODD9F SIDE

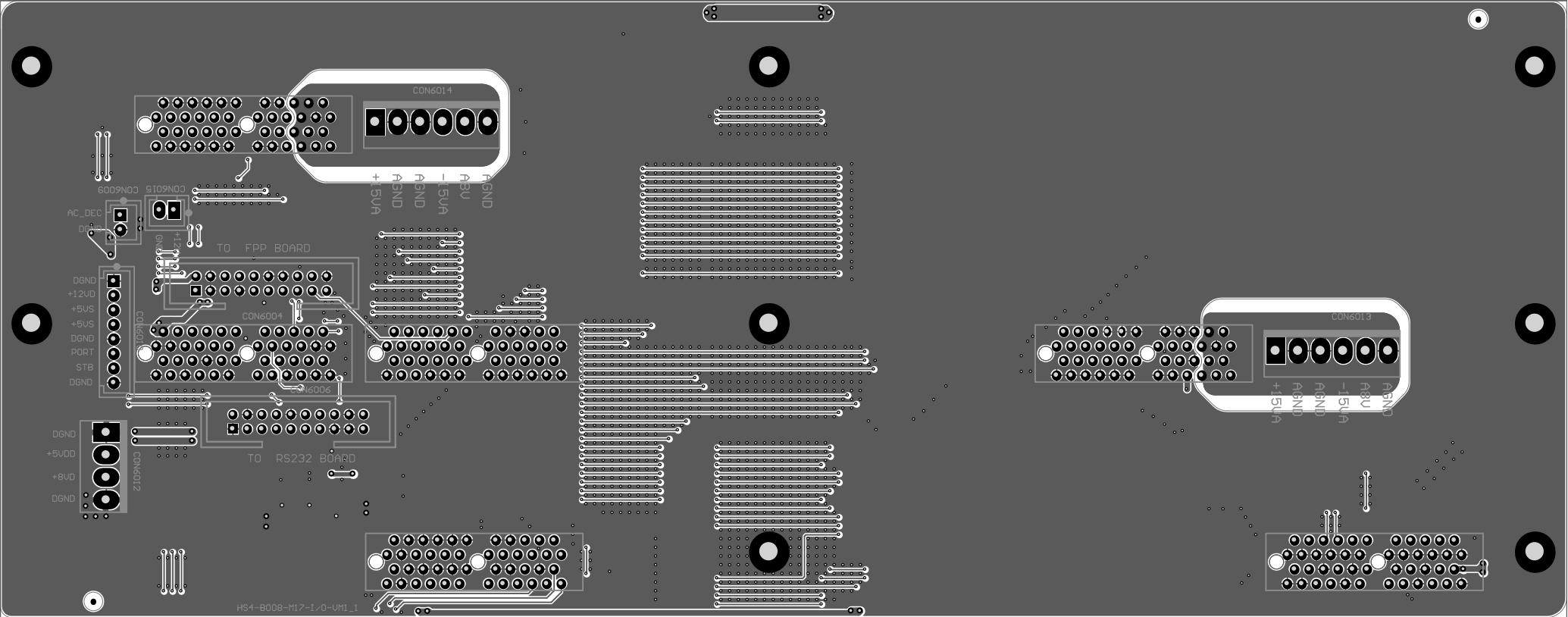

I / O BOARD - COADCB9BH SIDE

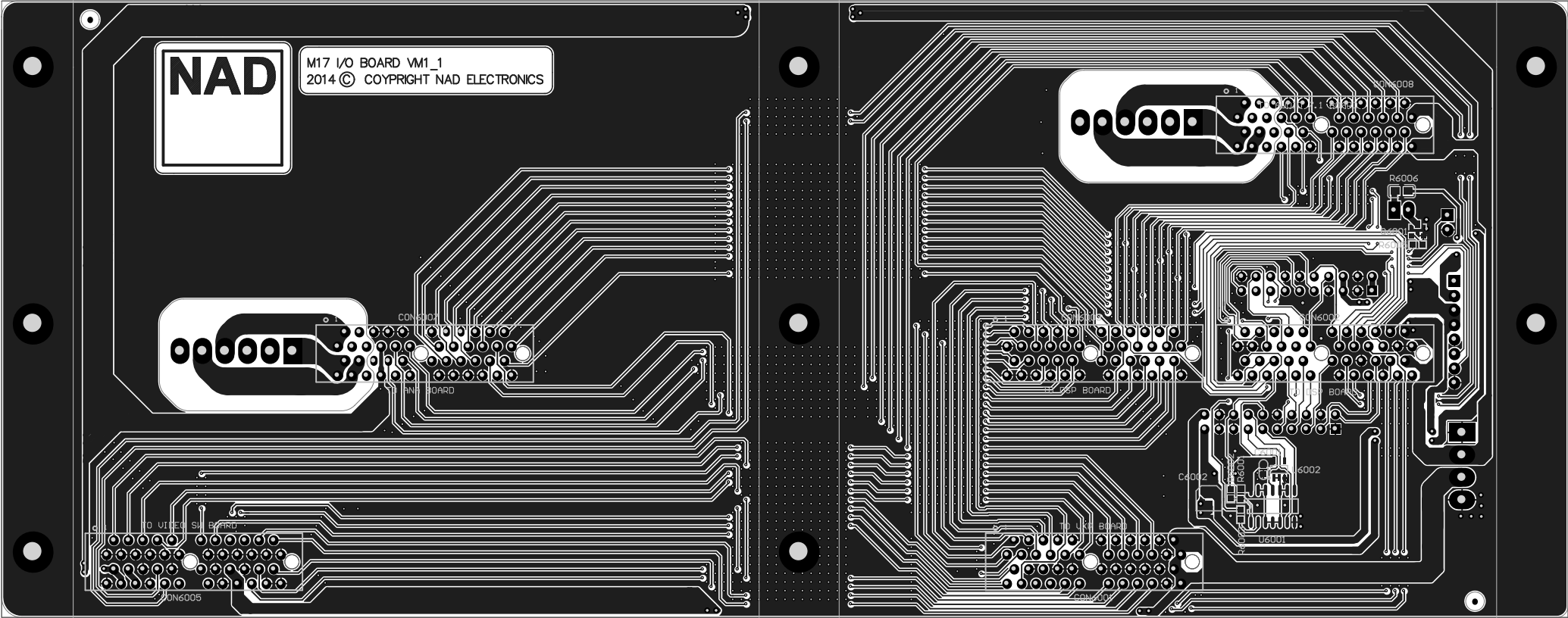

LED DRIVER- COPPER SIDE

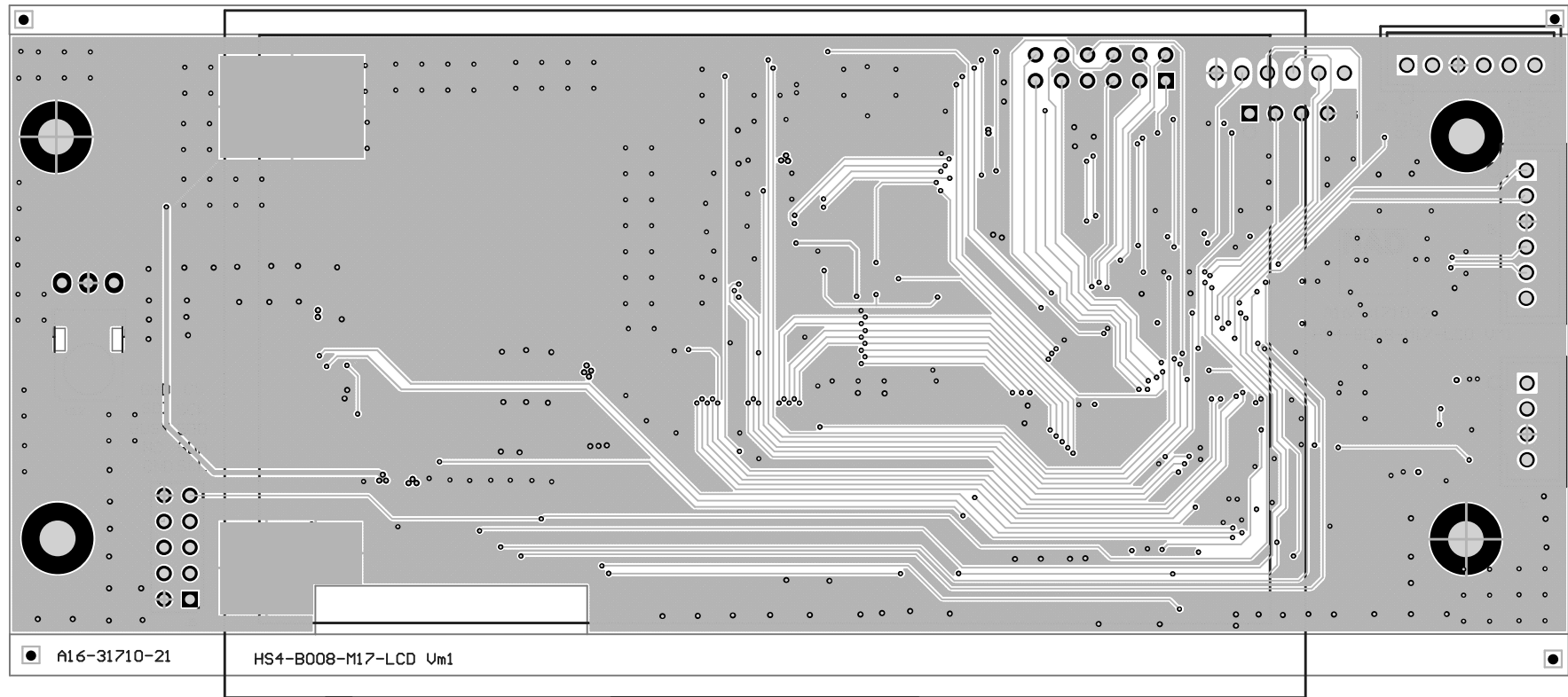

LED DRIVER-COMPONENT SIDE

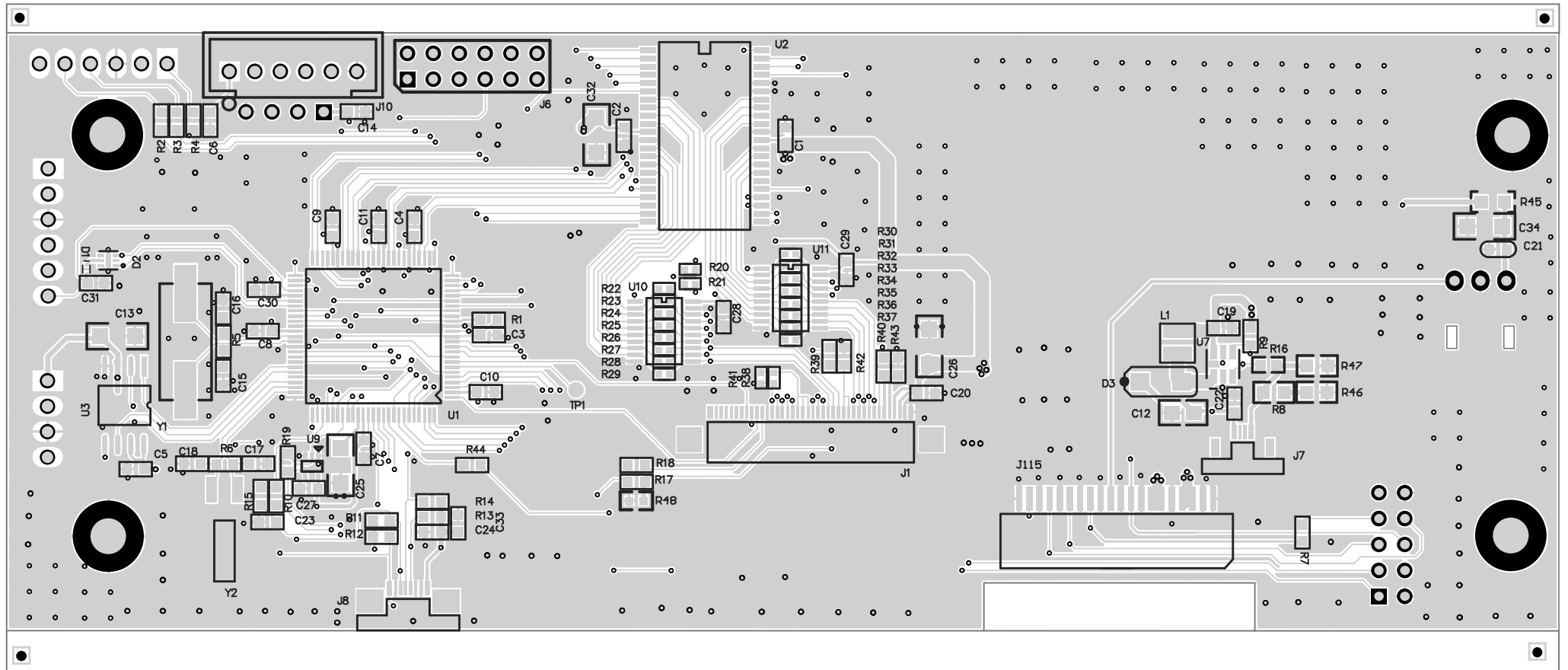

PSU A BOARD - COPPER SIDE

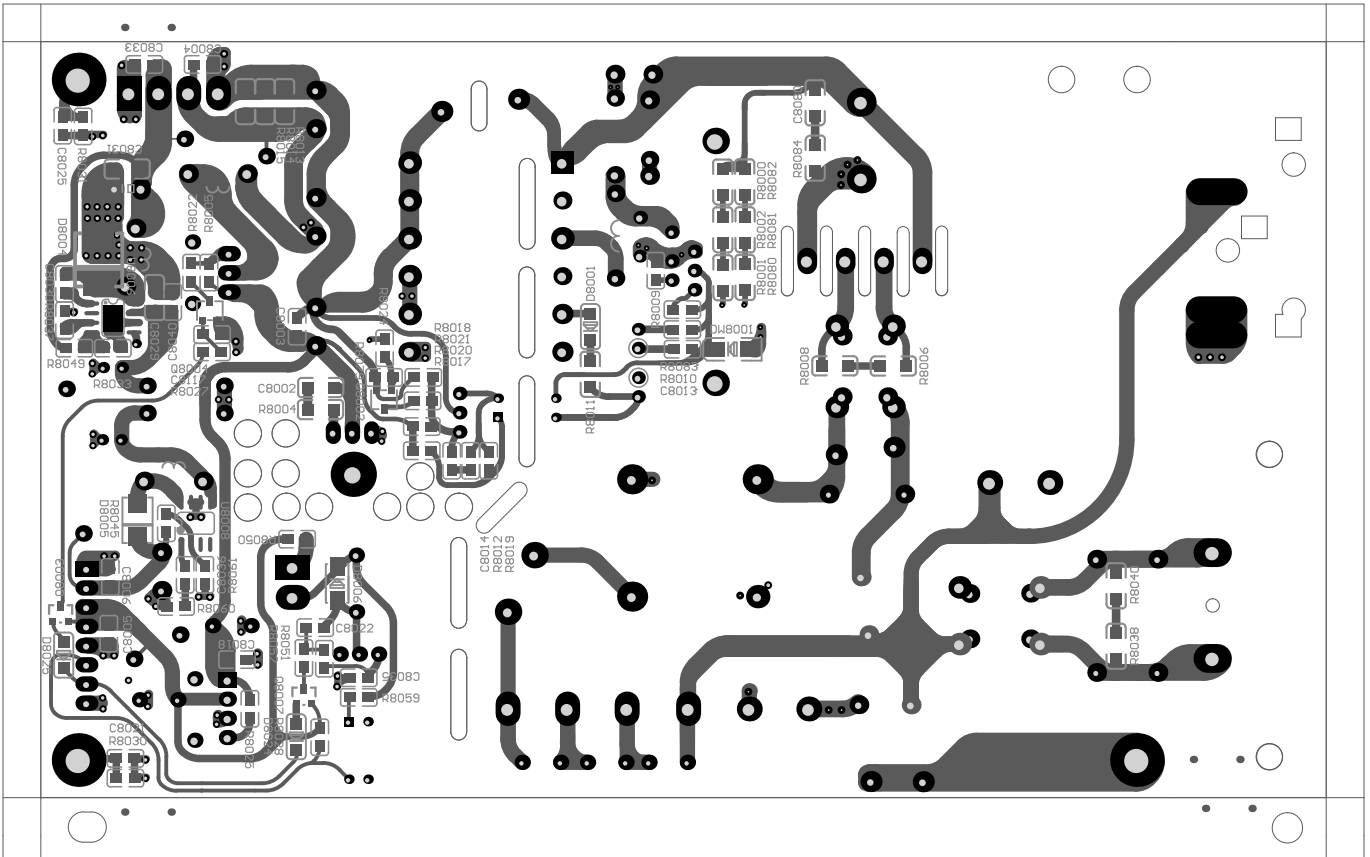

PSU A BOARD - COMPONENT SIDE

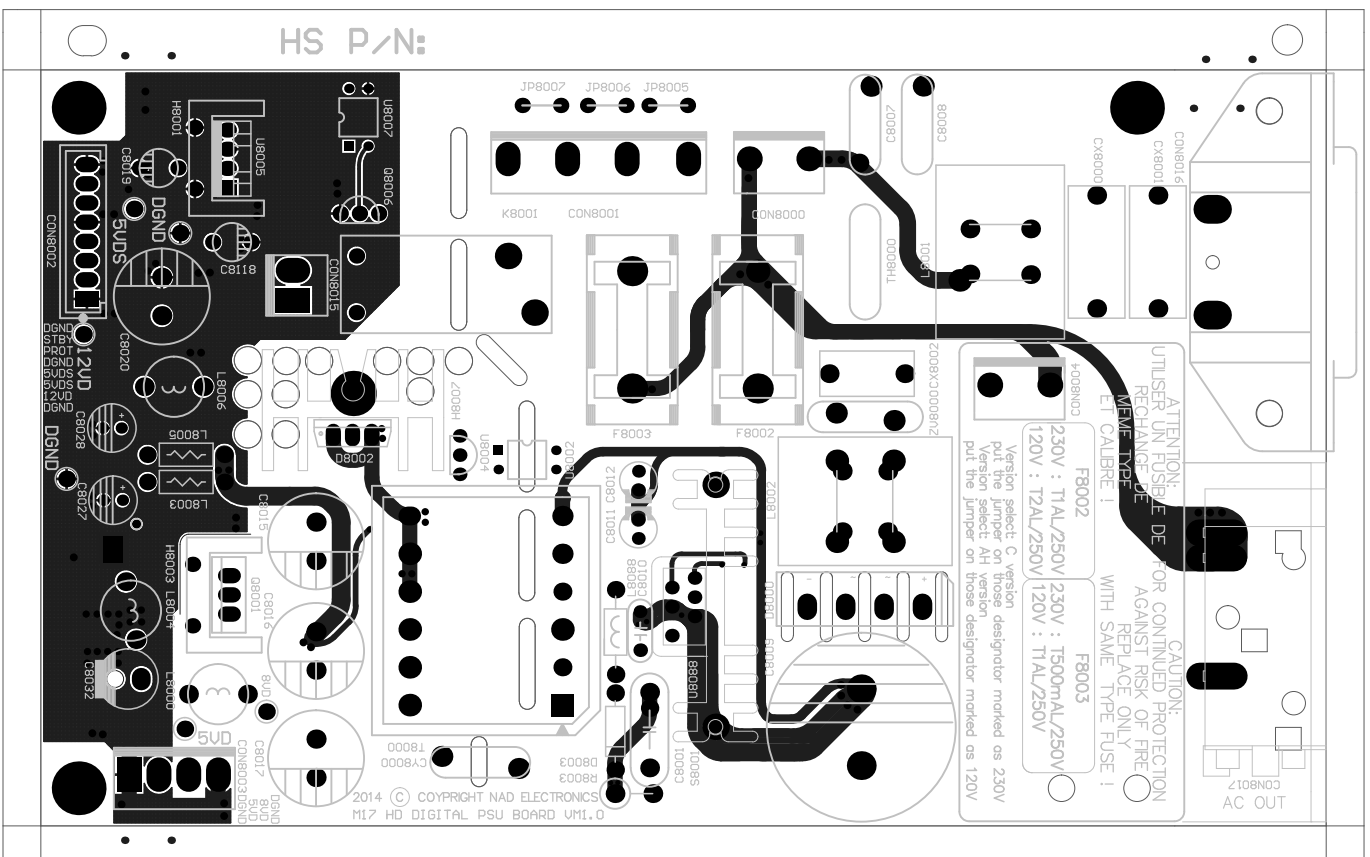

PSU B BOARD - COPPER SIDE

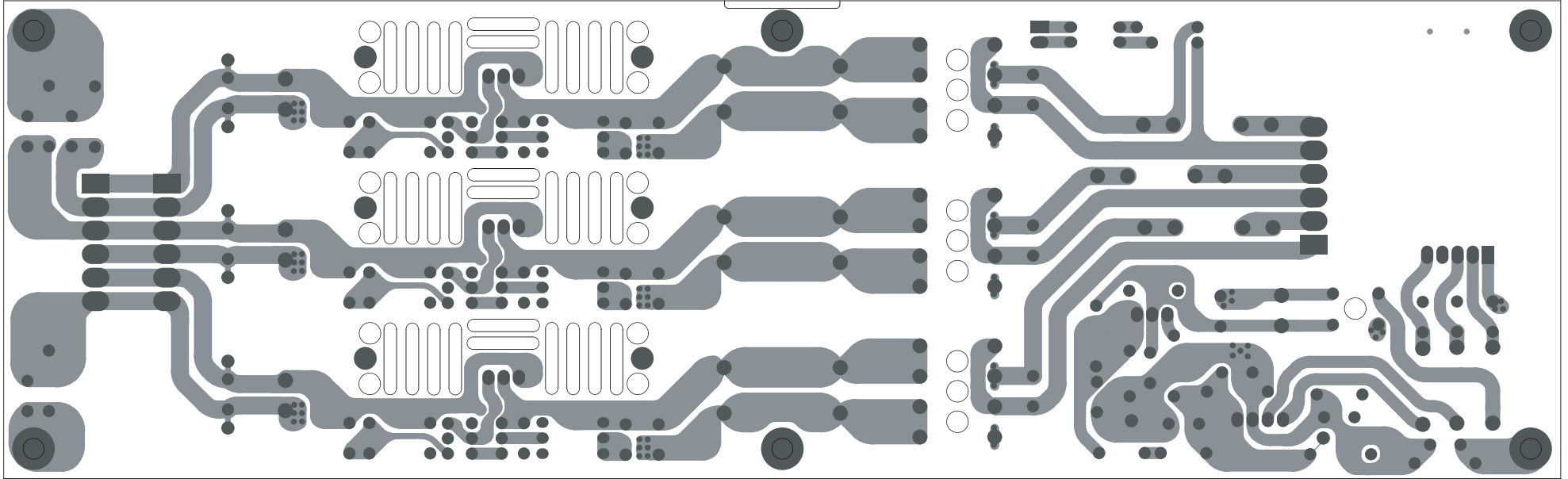

PSU B BOARD - COMPONENT SIDE

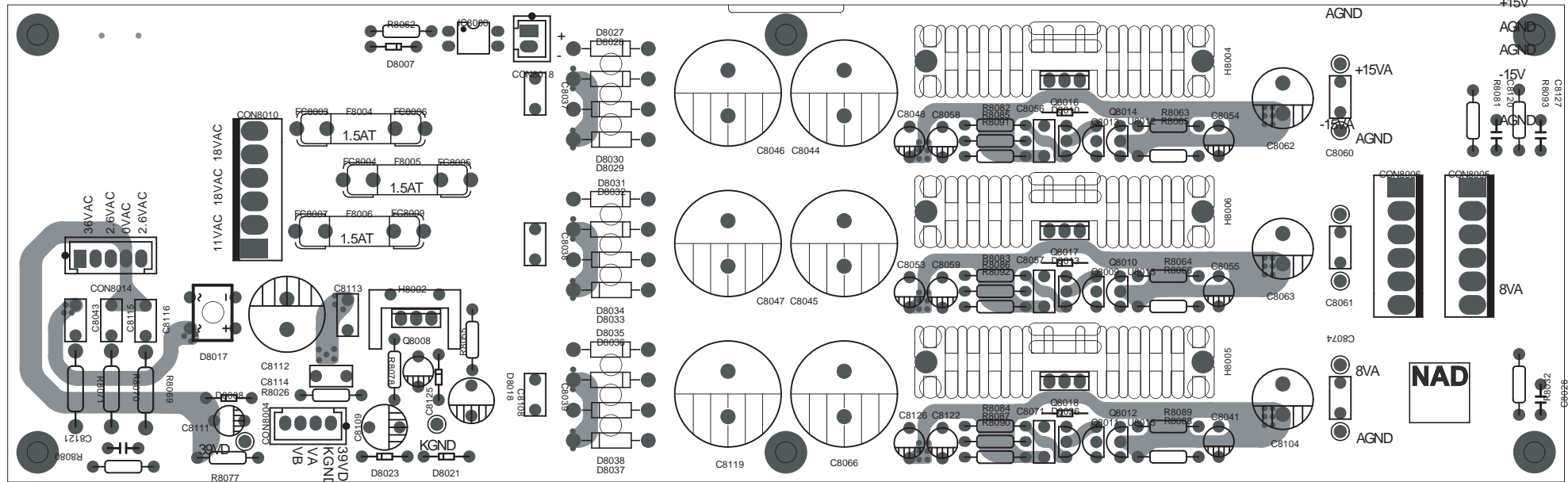

AUDIO ANALOG BOARD - COPPER SIDE

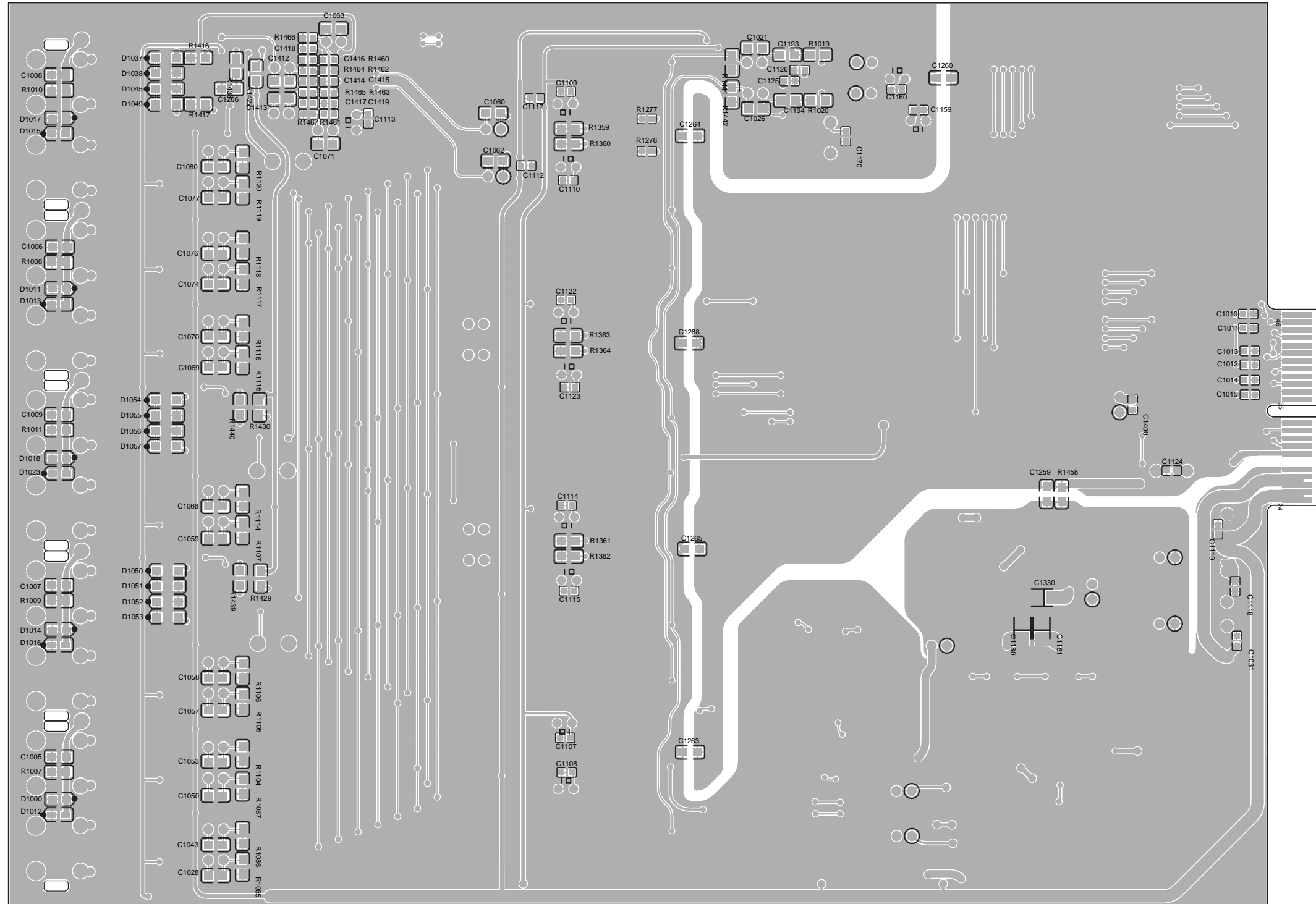

SWITCH BOARD - COPPER SIDE

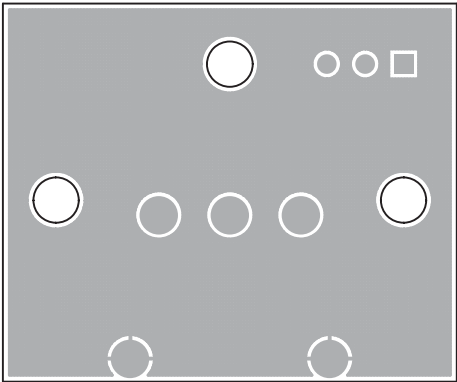

SWITCH BOARD - COMPONENT SIDE

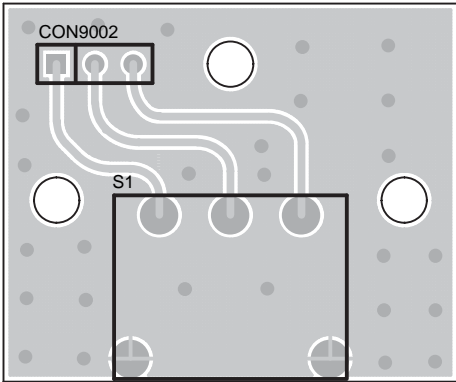

TRIGGER BOARD - COPPER SIDE

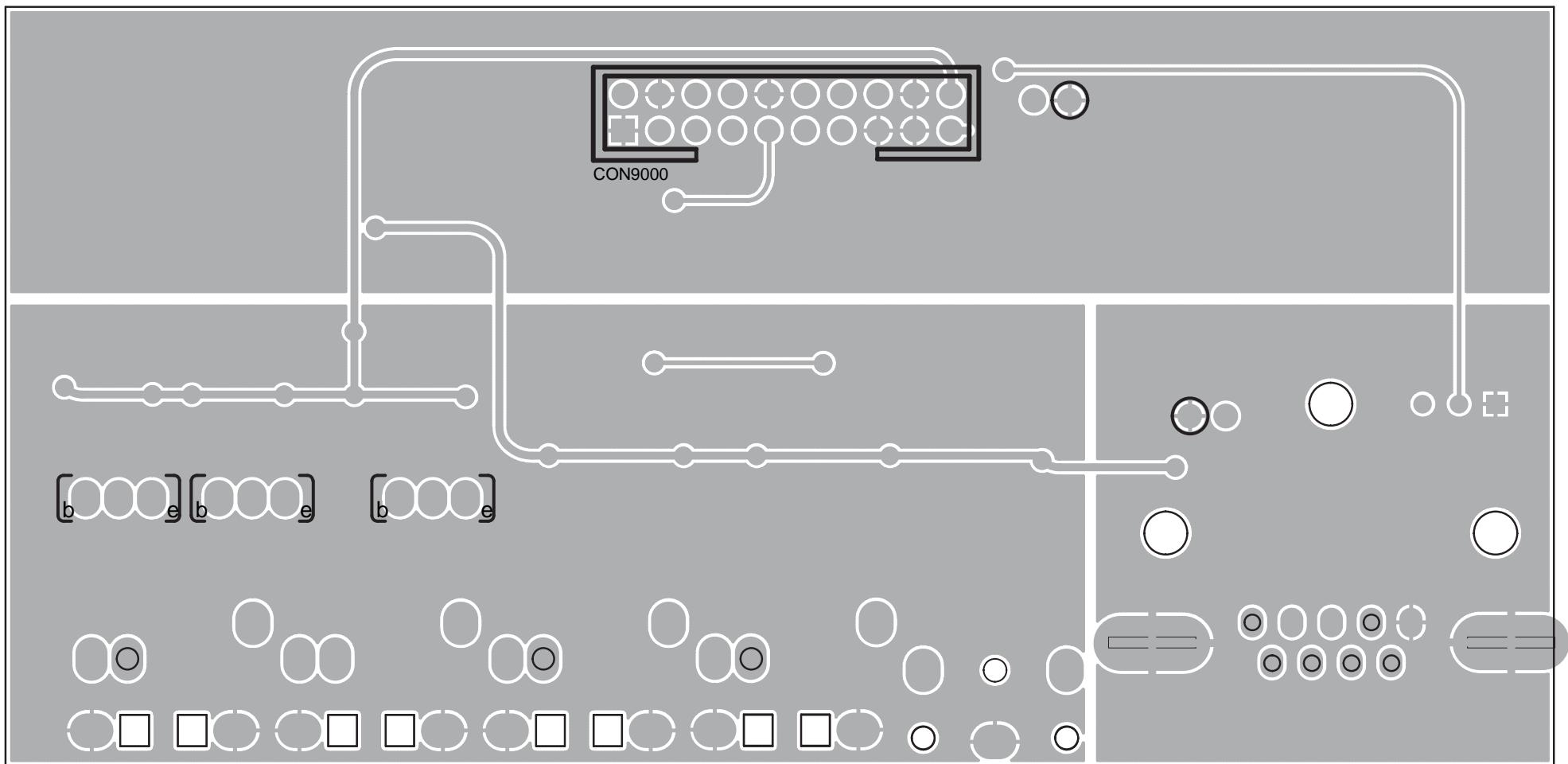

TRIGGER BOARD - COMPONENT SIDE

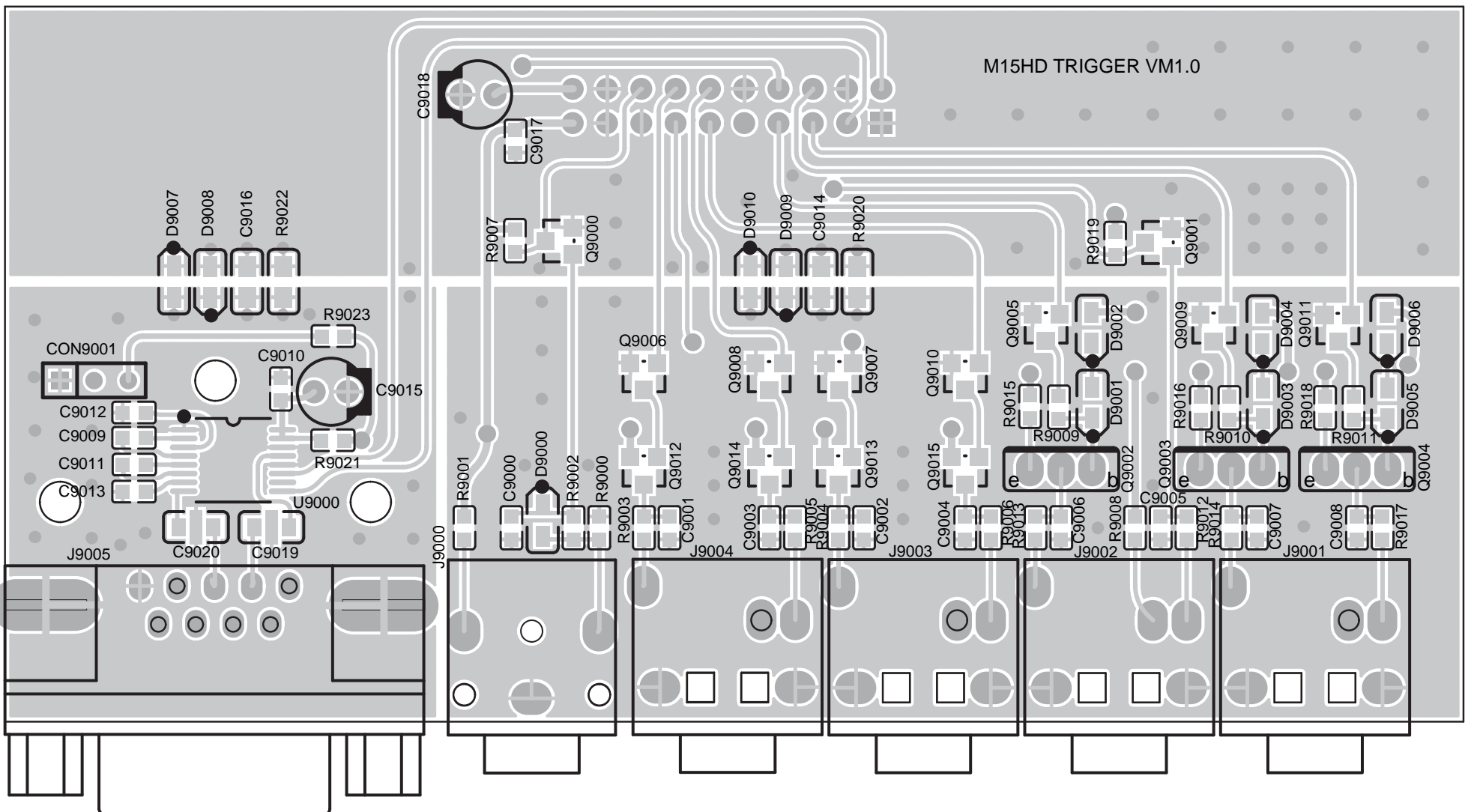

HDMI BOARD - CODD9F SIDE

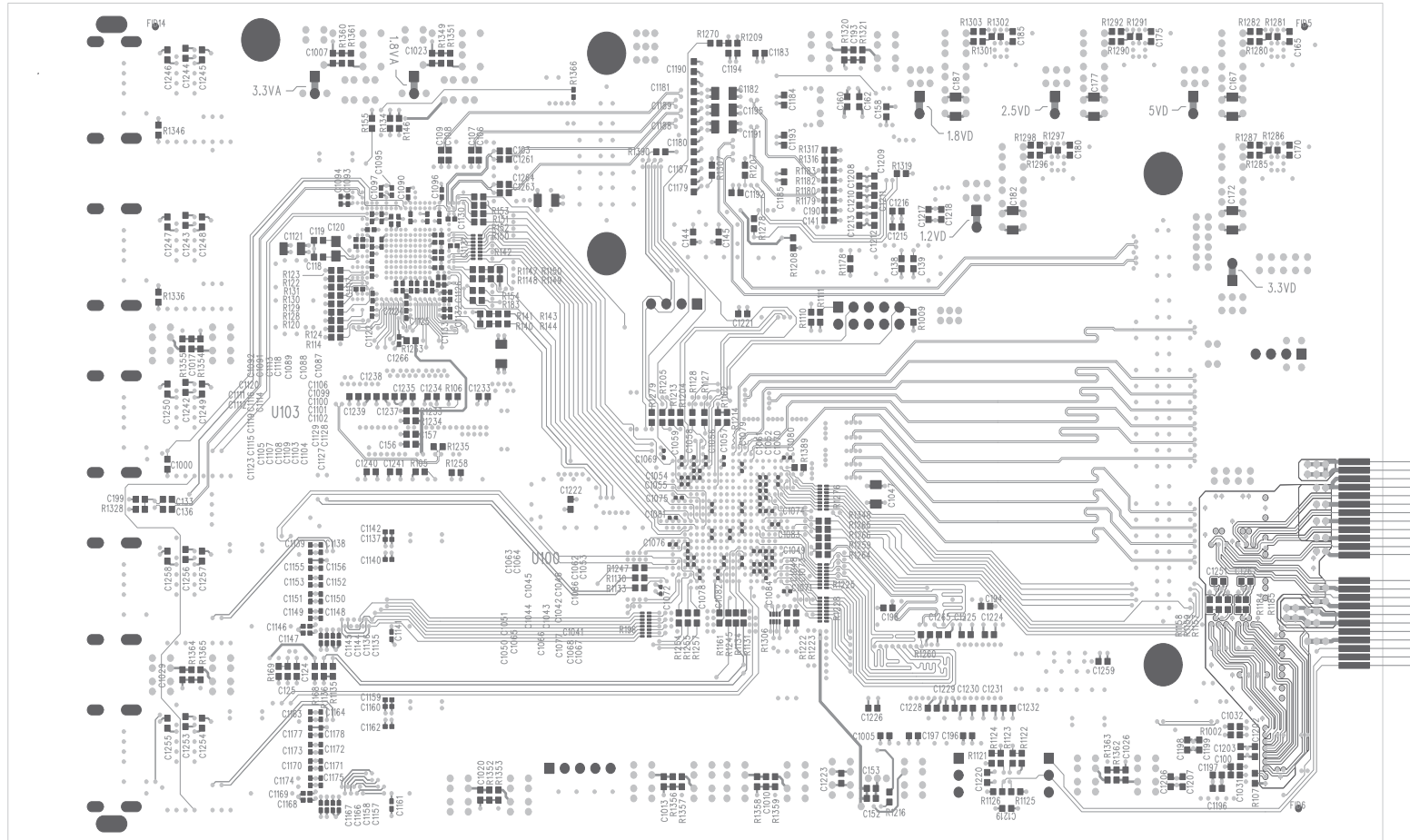

HDMI BOARD - COMPONENT SIDE

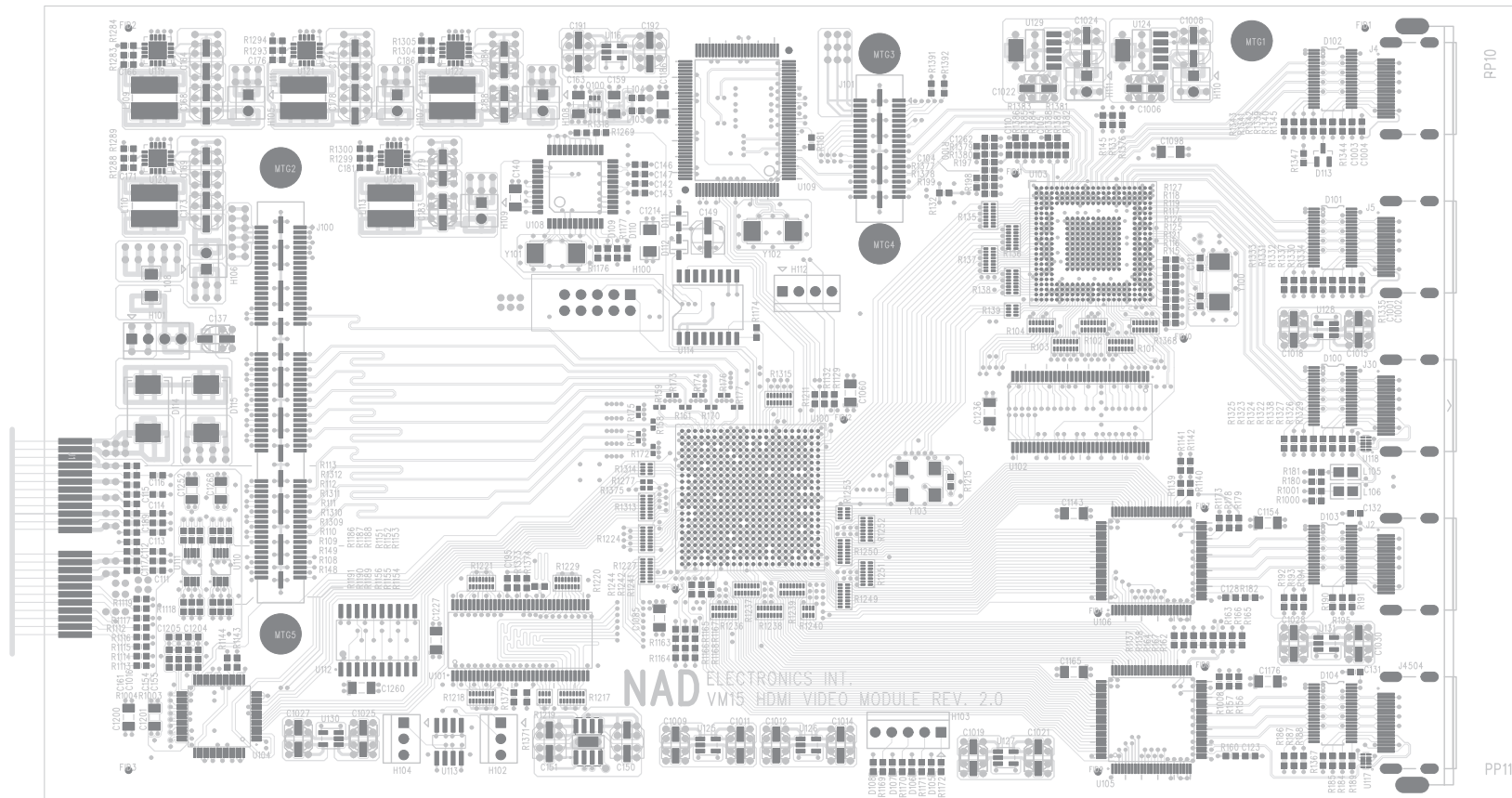

BKT1

HDMI EXPANDER BOARD - CODD9F SIDE

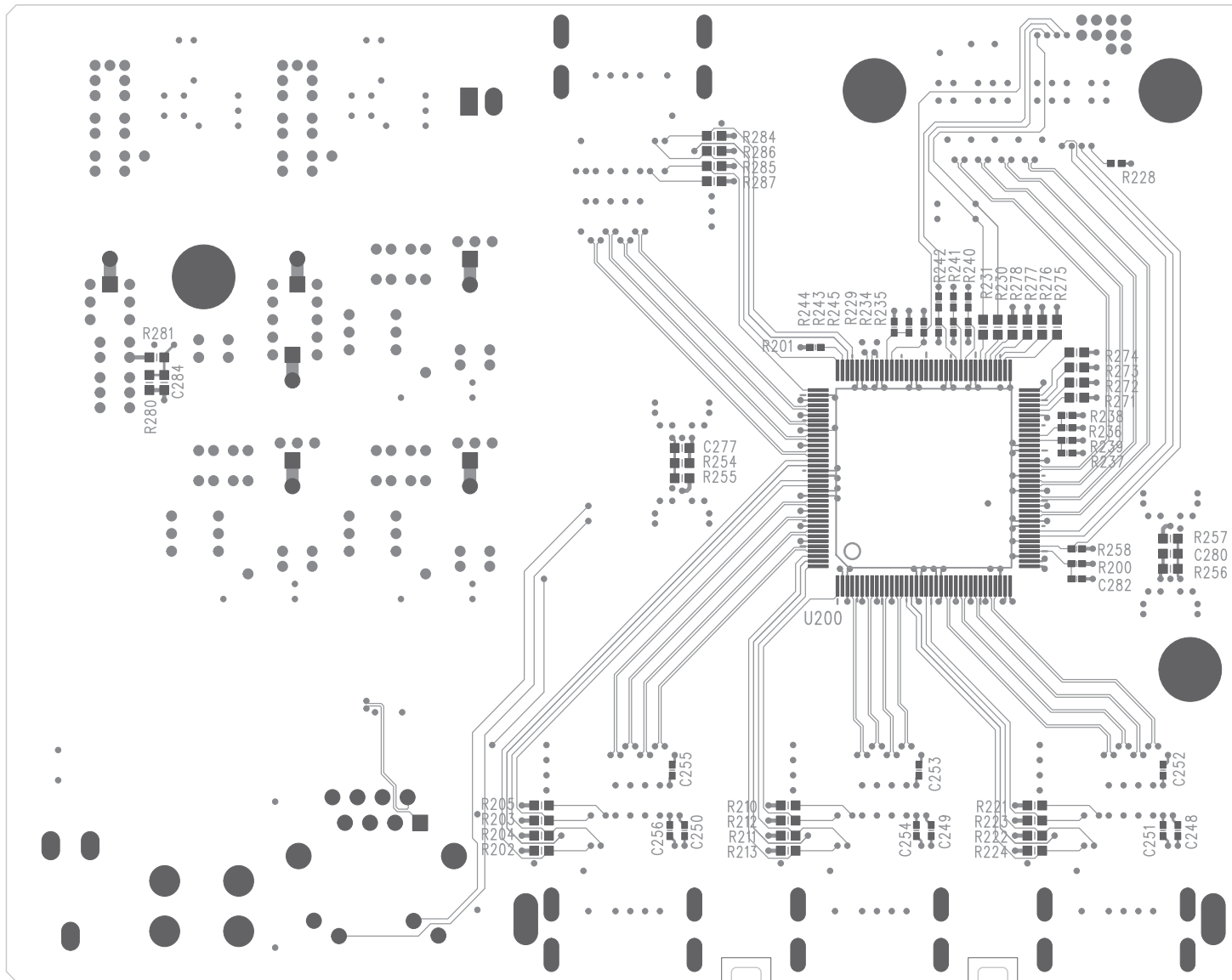

HDMI EXPANDER BOARD - COADC9BH SIDE

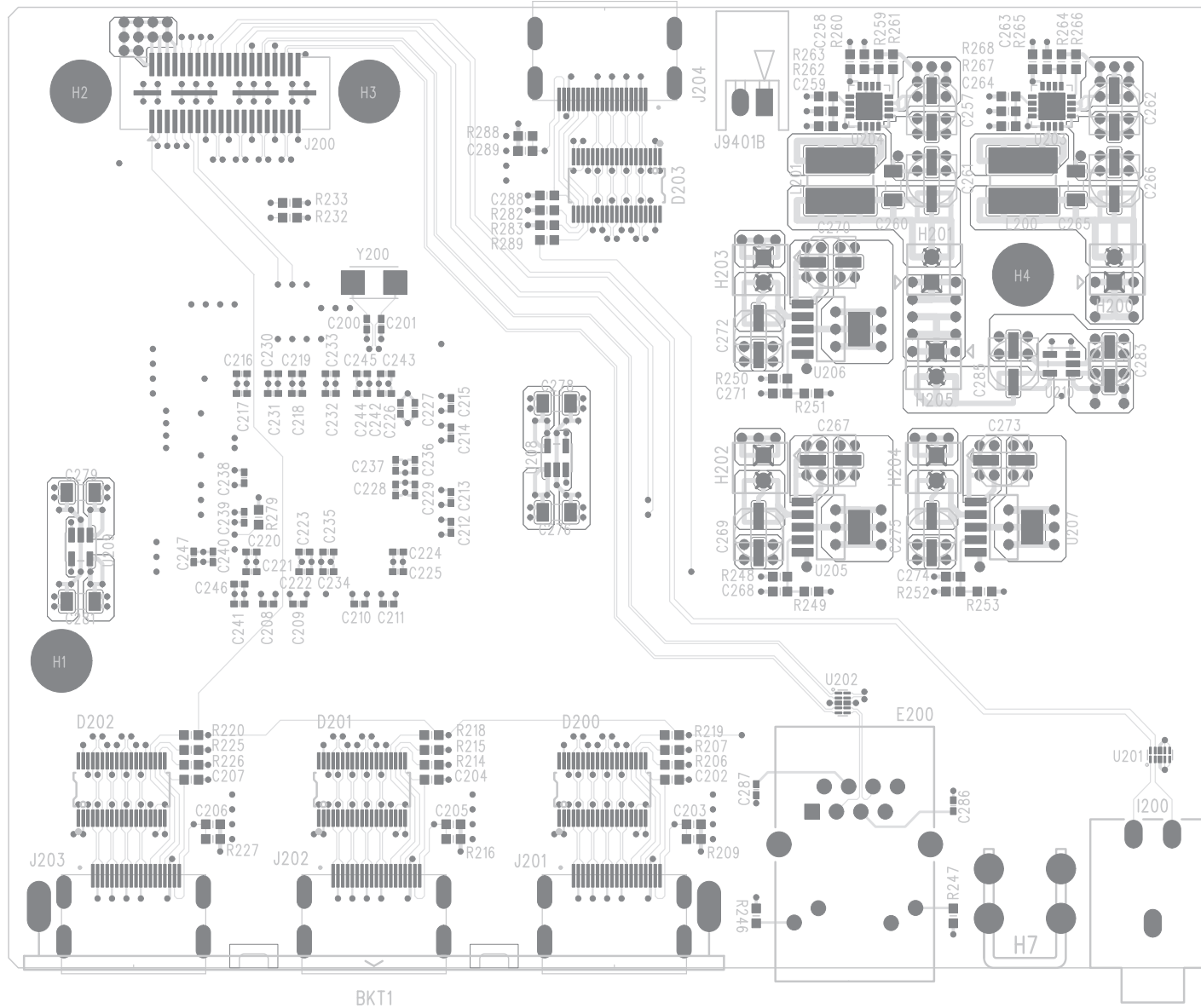

SCHEMATIC DIAGRAM

DSP-1

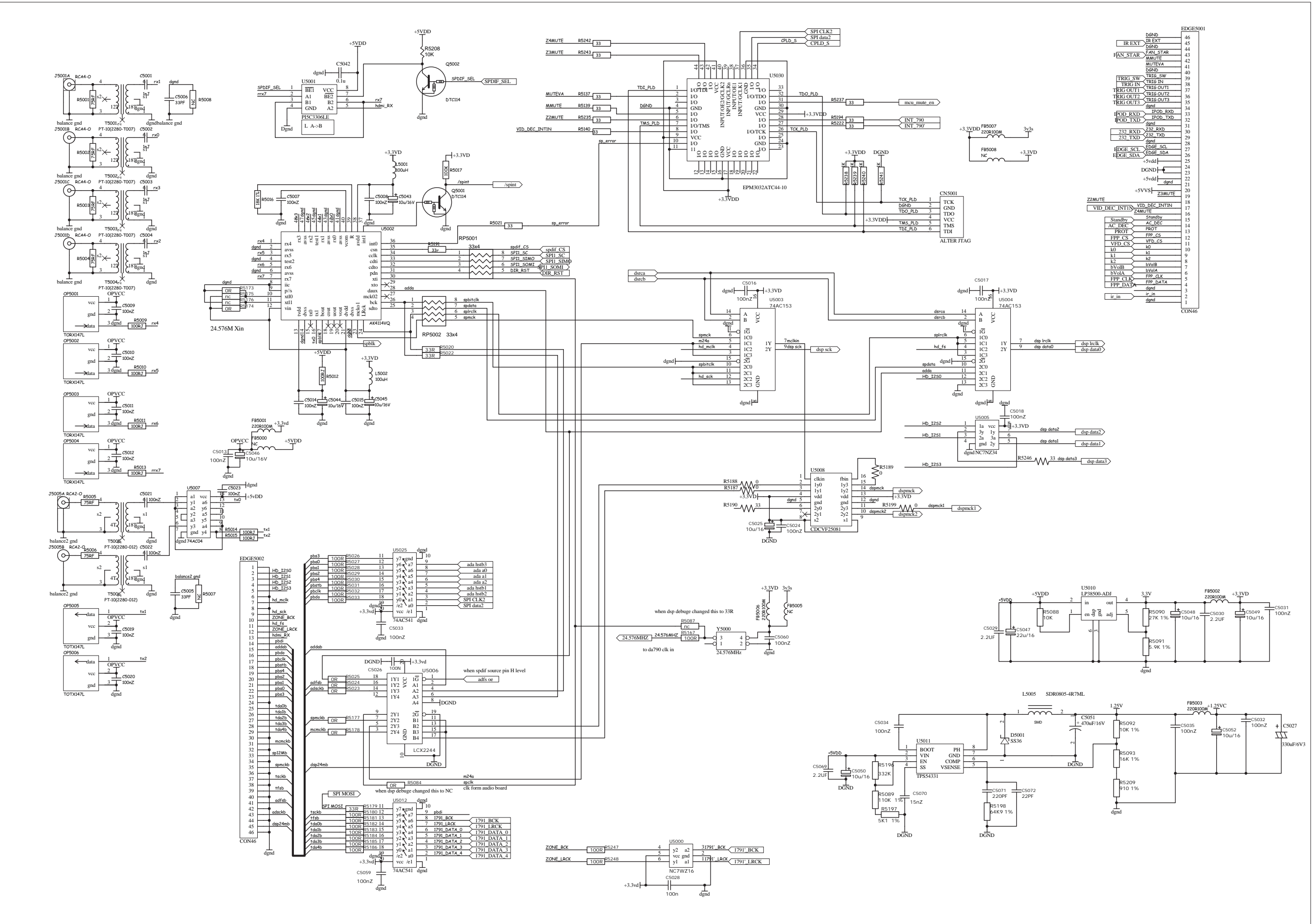

DSP-2

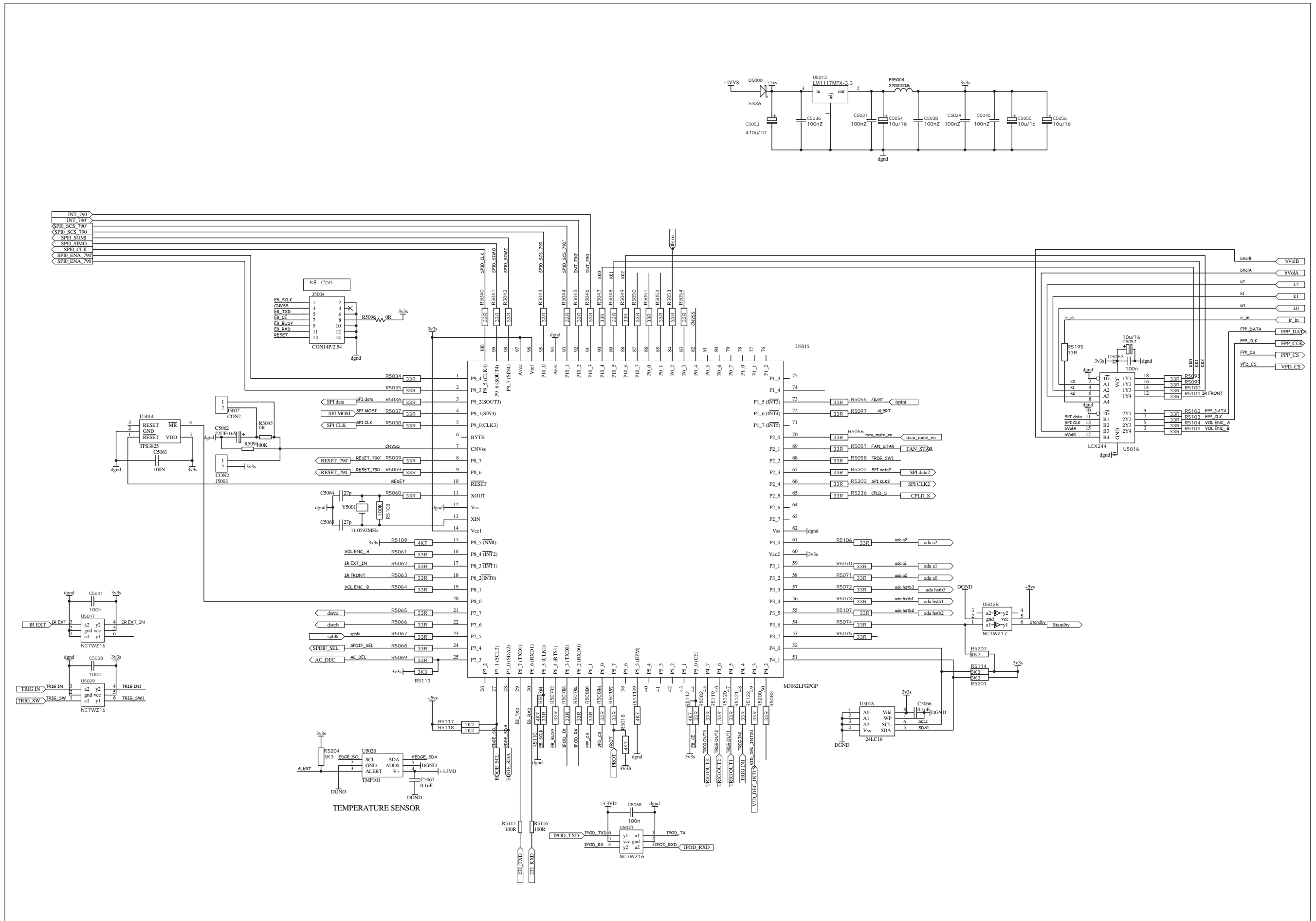

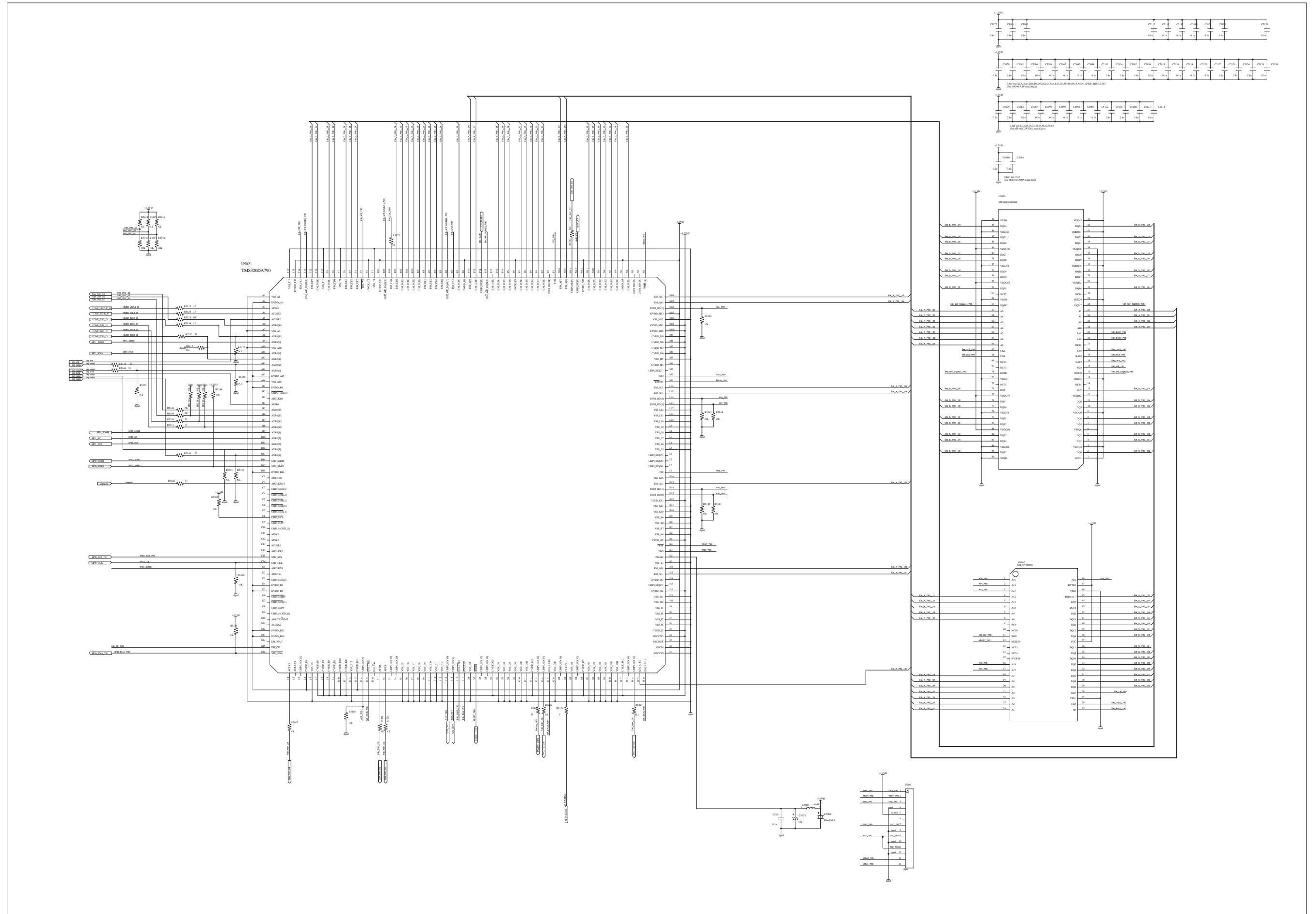

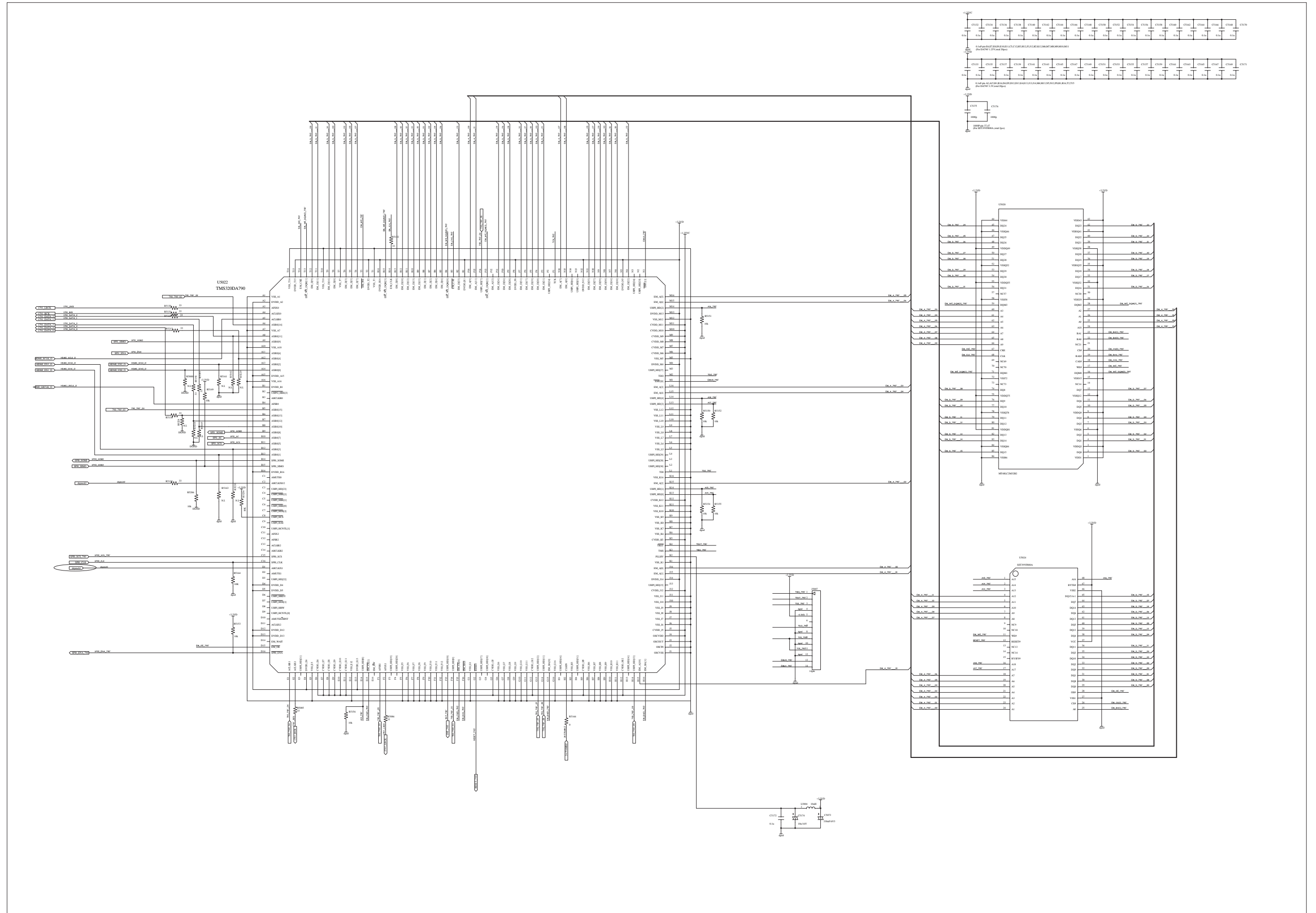

KEYBOARD

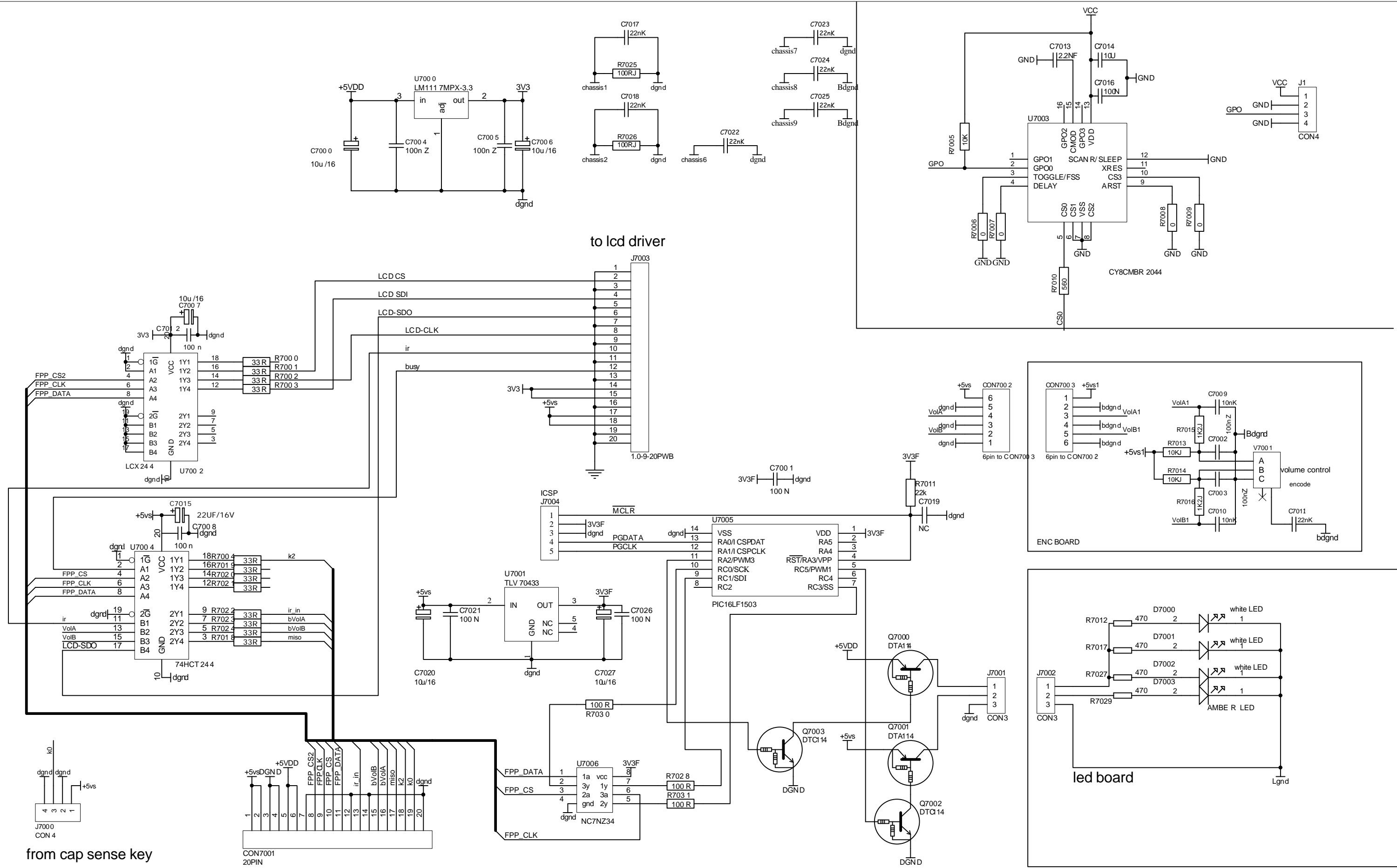

from cap sense key

m15hd	mcu pin	m17
k0	p10.4	stb key L active
miso	p9.1	lcd miso
k2	p10.6	lcd busy

VIDEO BOARD

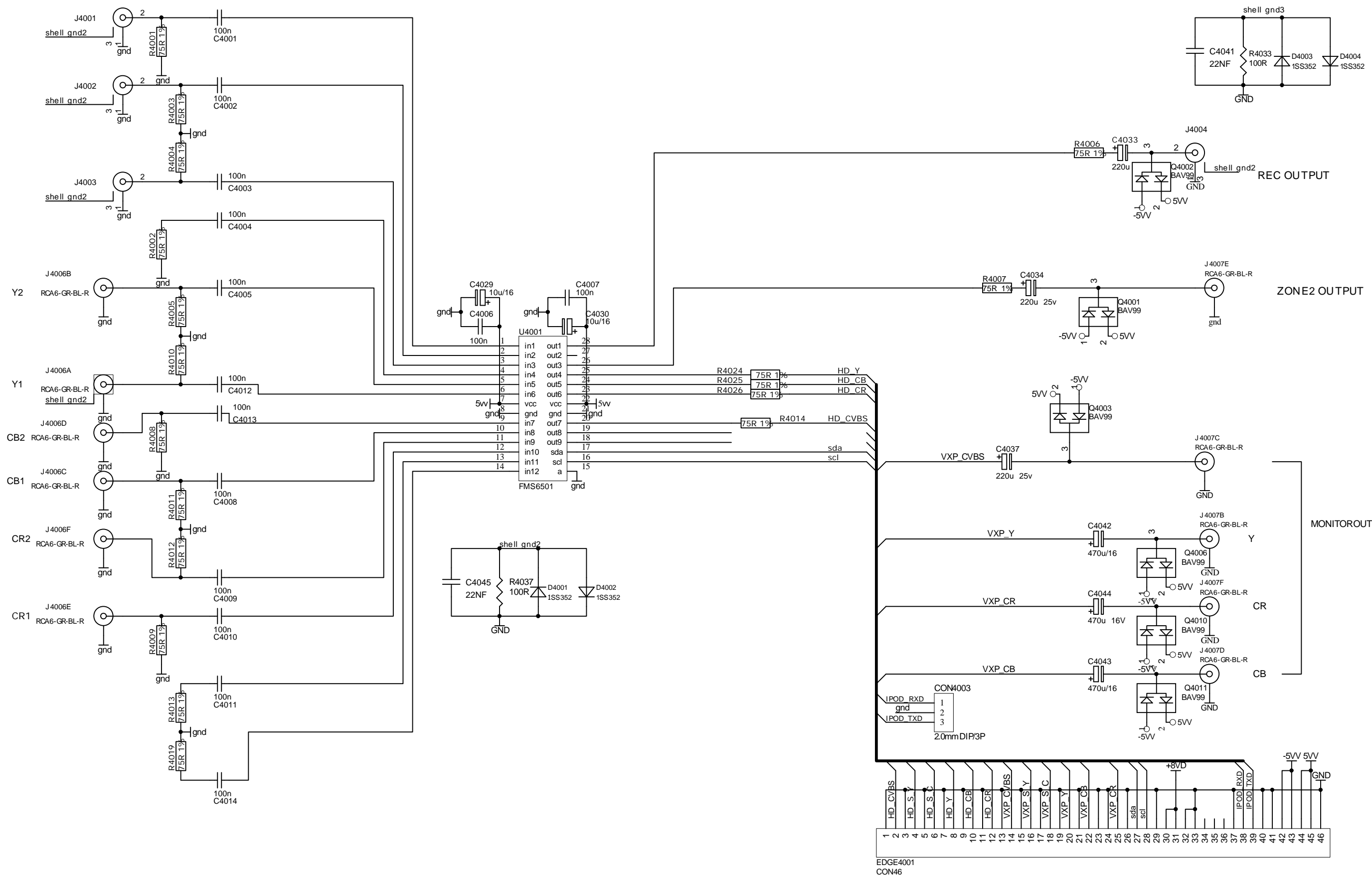

AUDIO 7.1 BOARD

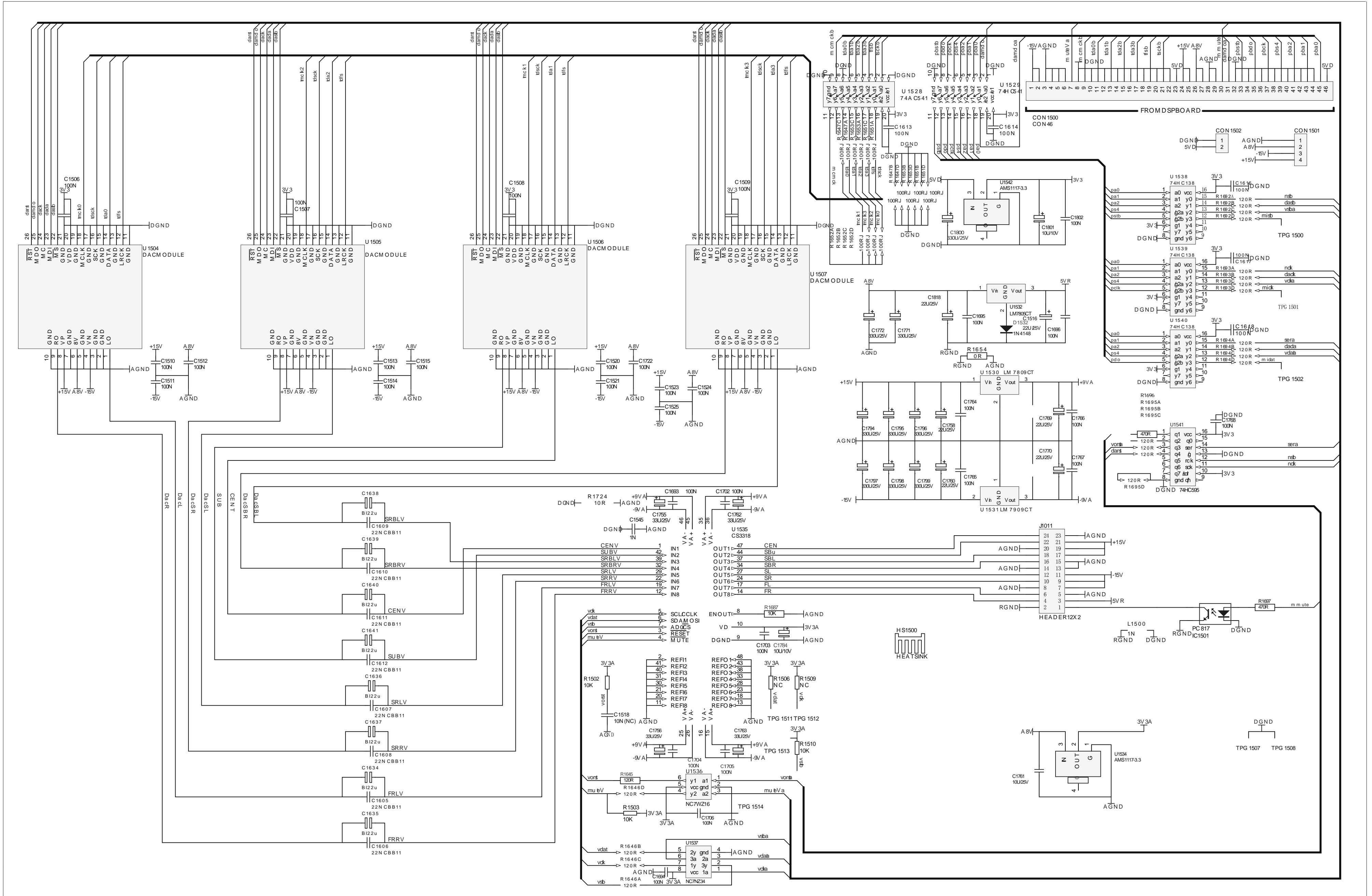

AUDIO INTERFACE BOARD

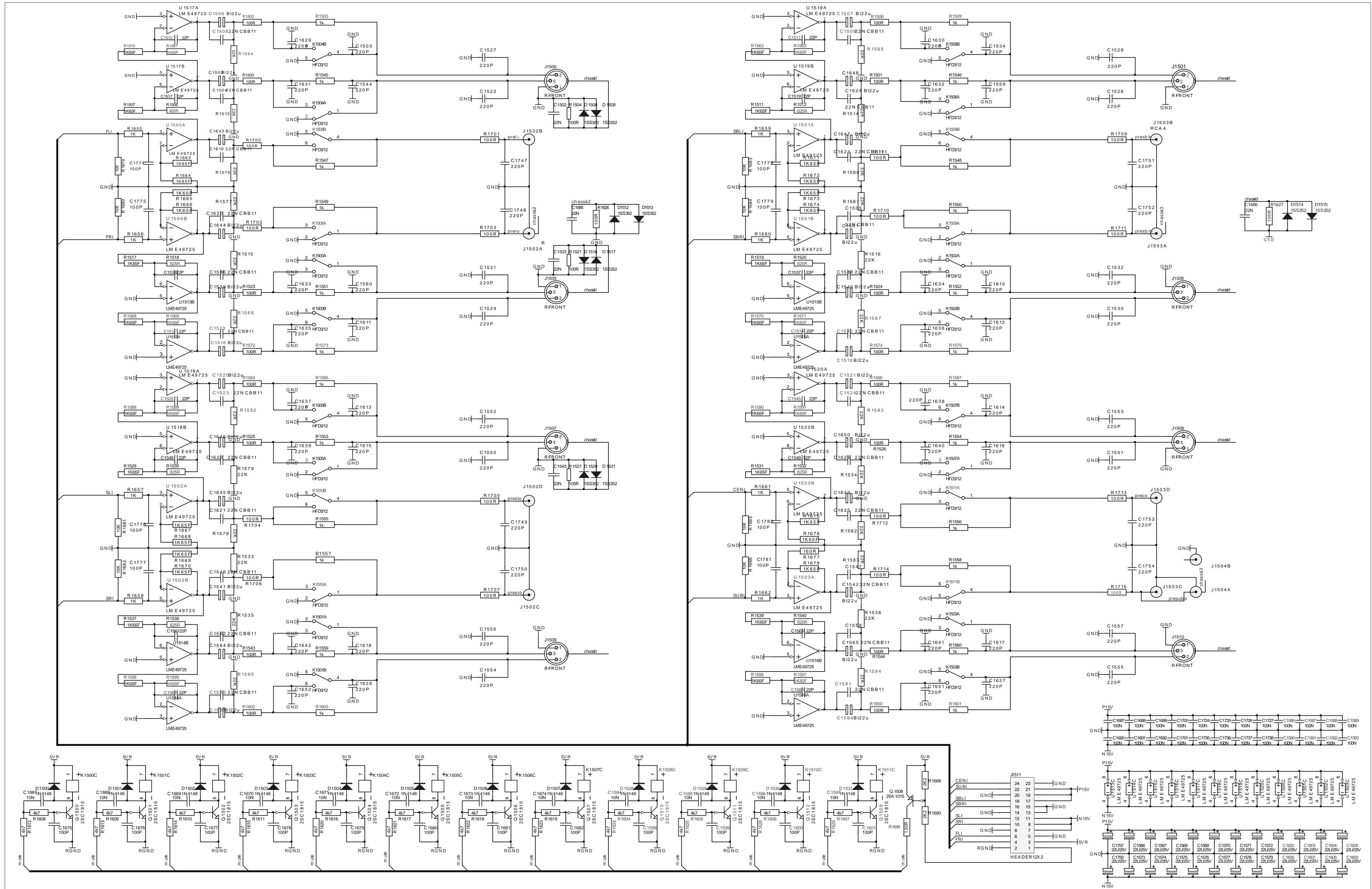

I/O BOARD

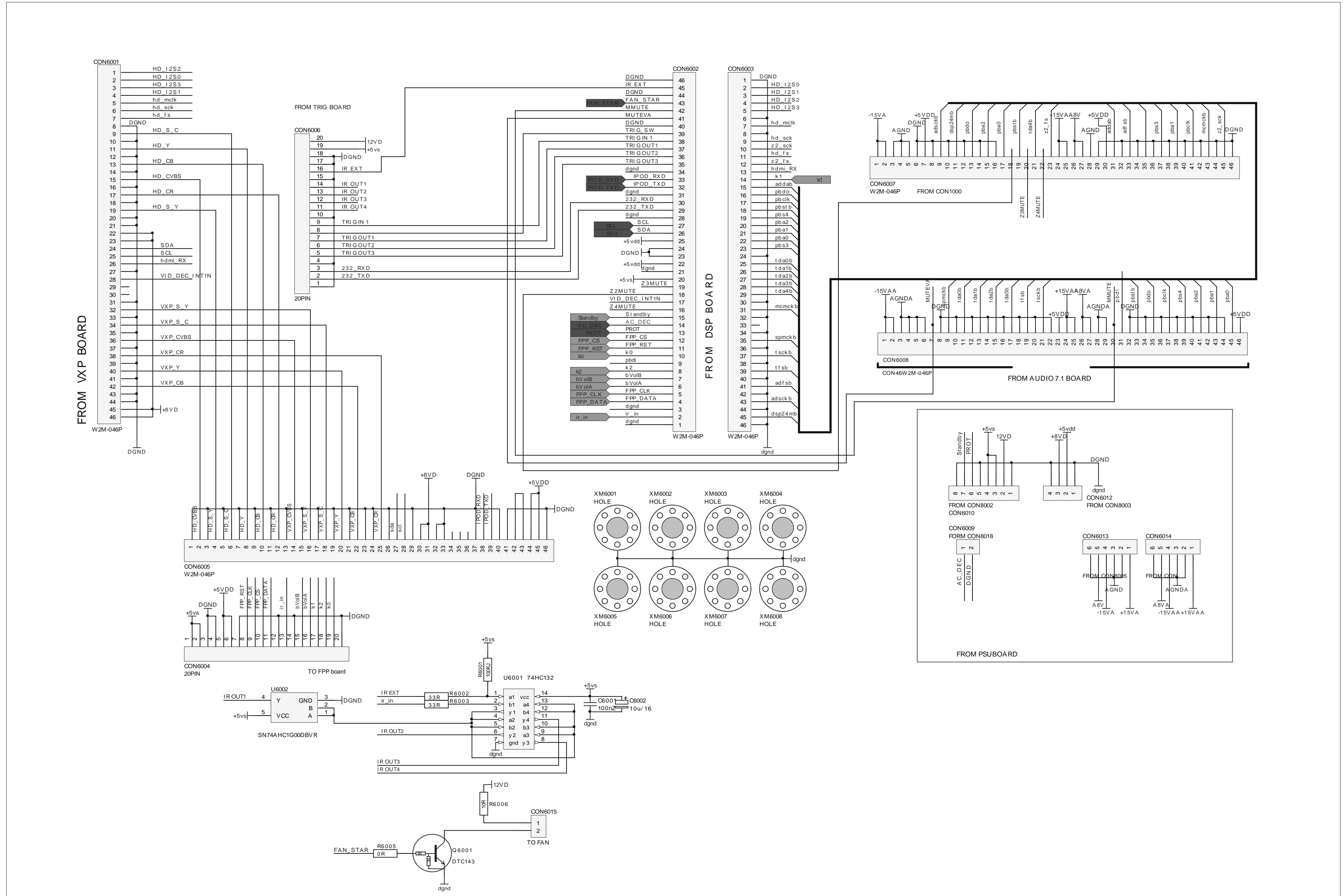

LED DRIVER BOARD

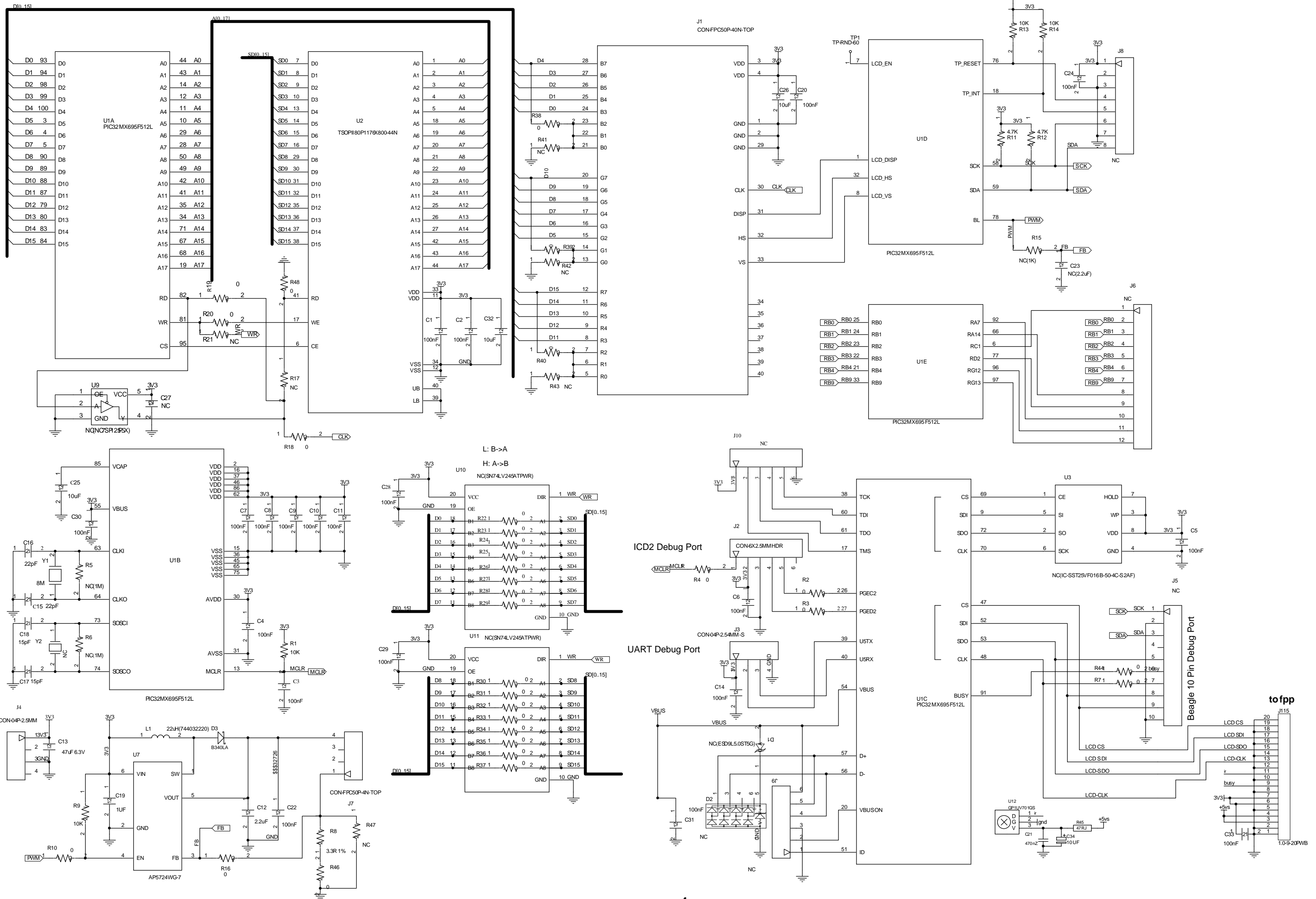

PSU A AND PSU B BOARD

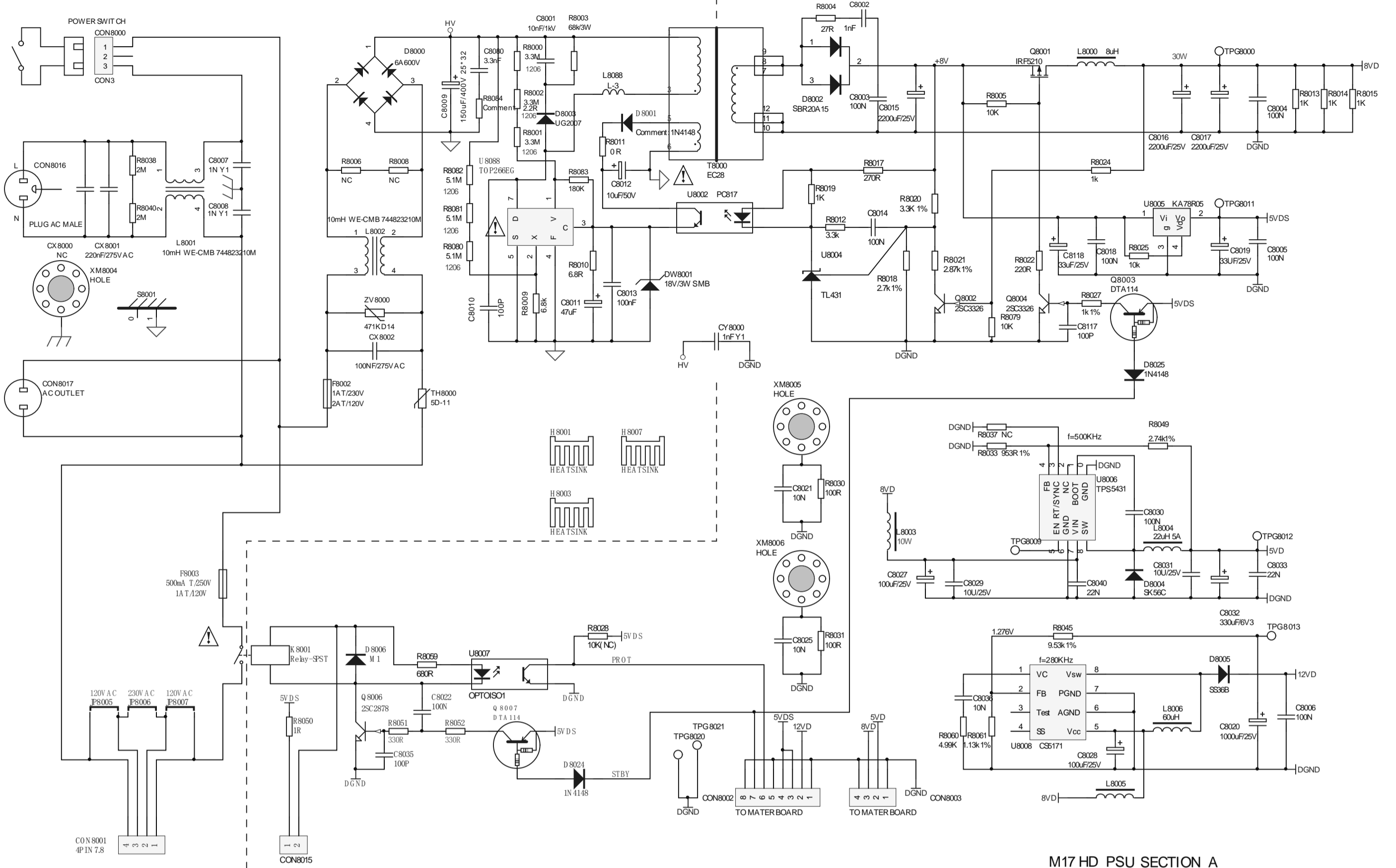

M17 HD PSU SECTION A

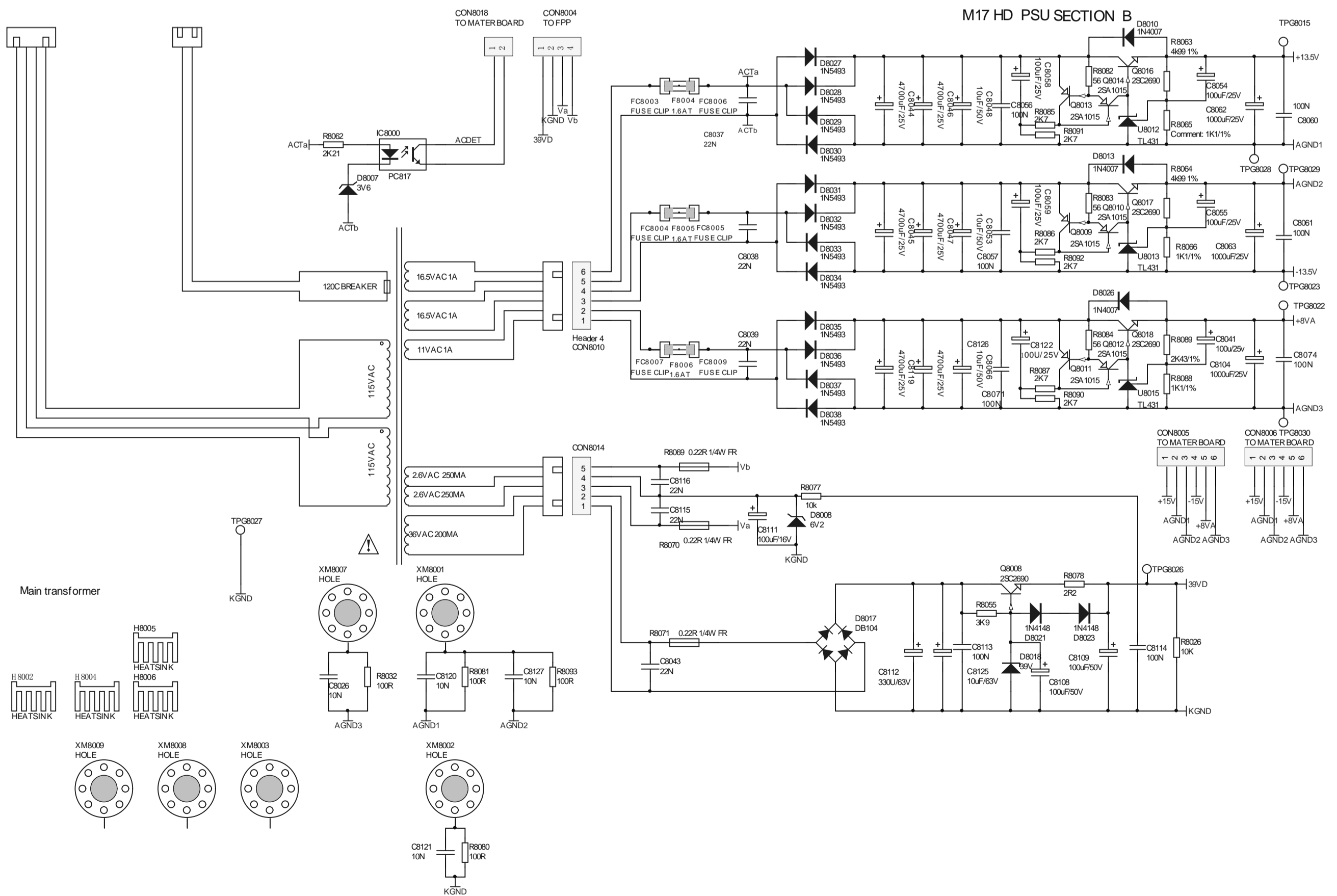

M17 HD PSU SECTION B

AUDIO ANALOG BOARD

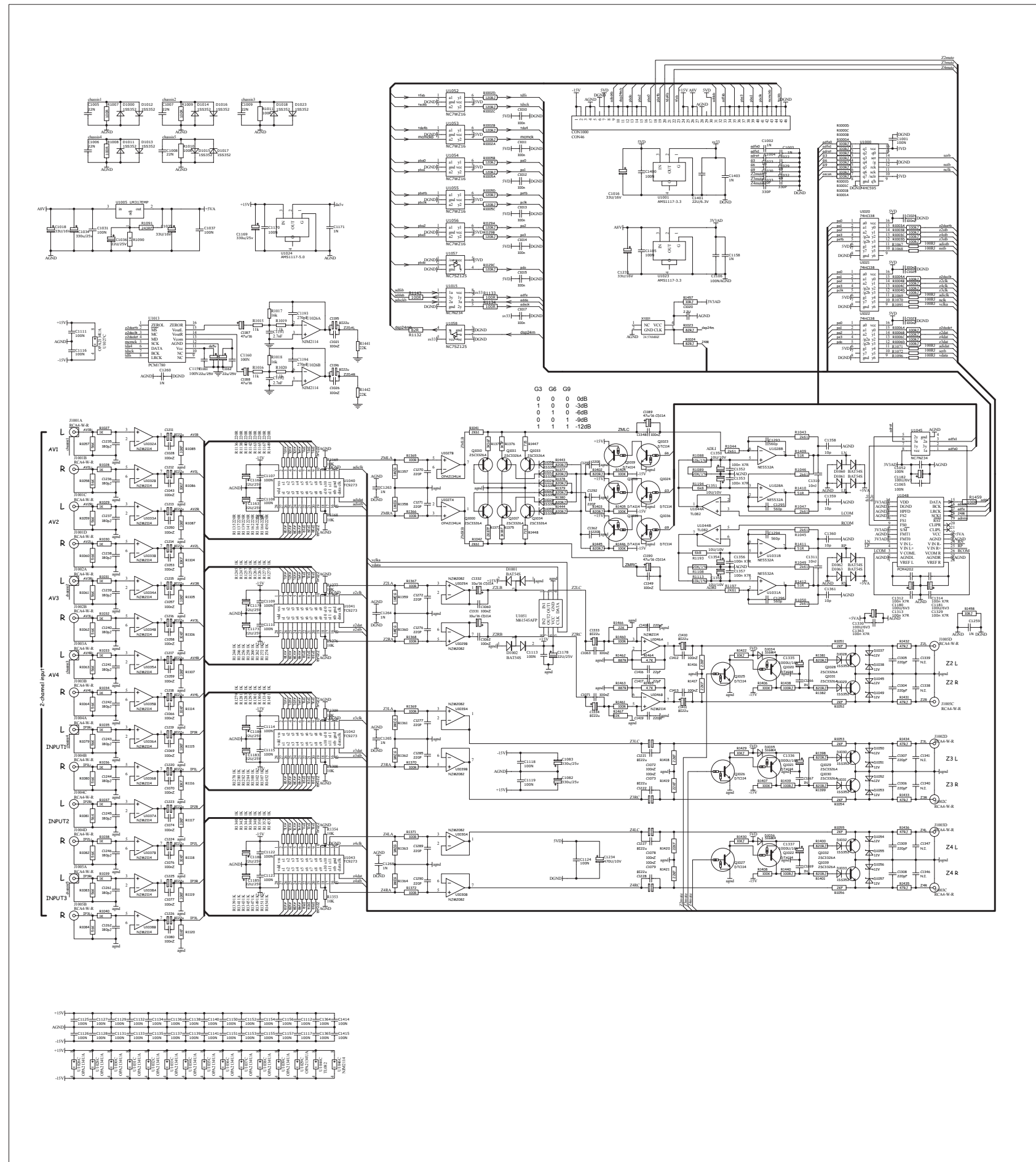

DAC BOARD

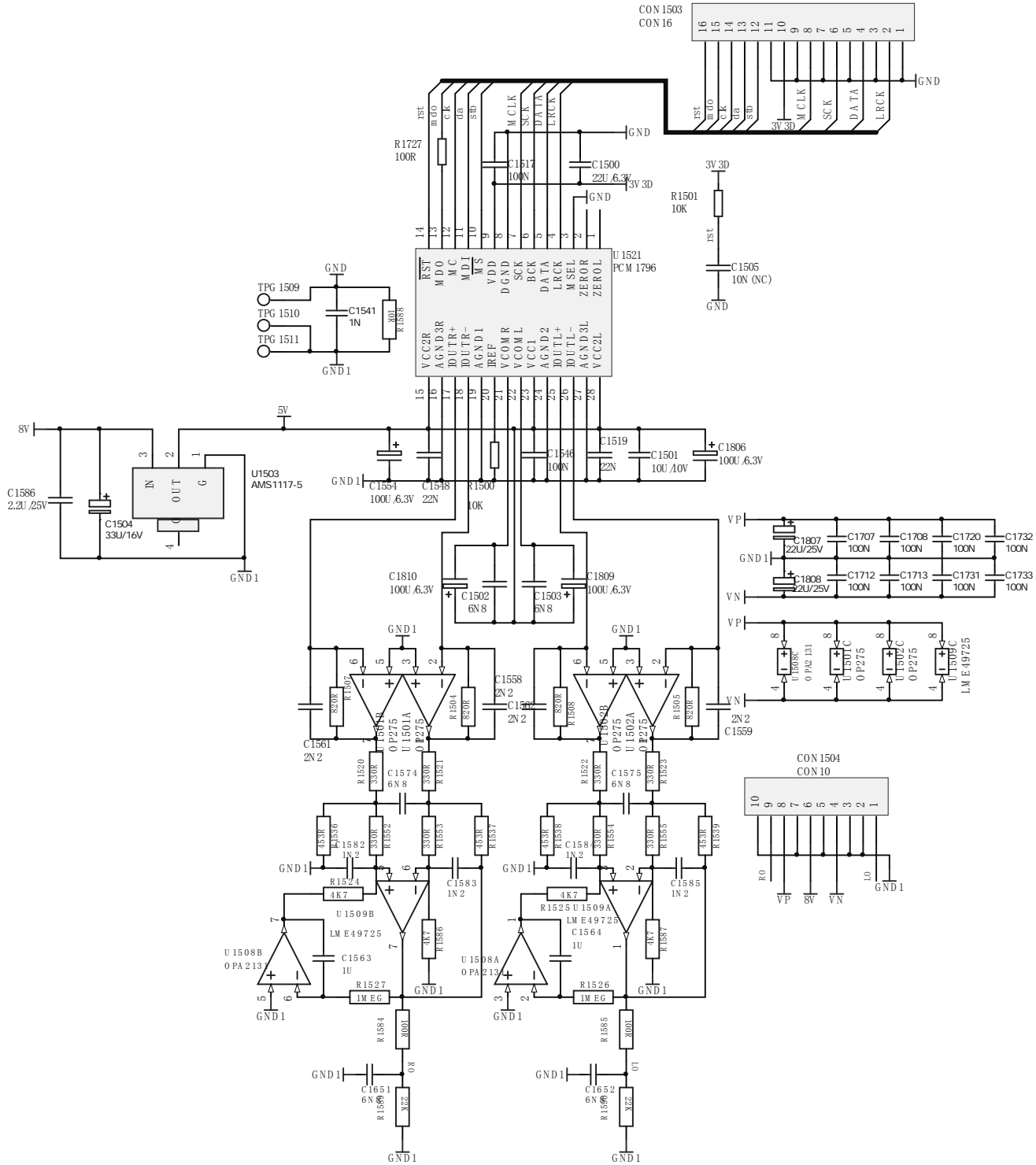

TRIGGER AND SWITCH BOARD

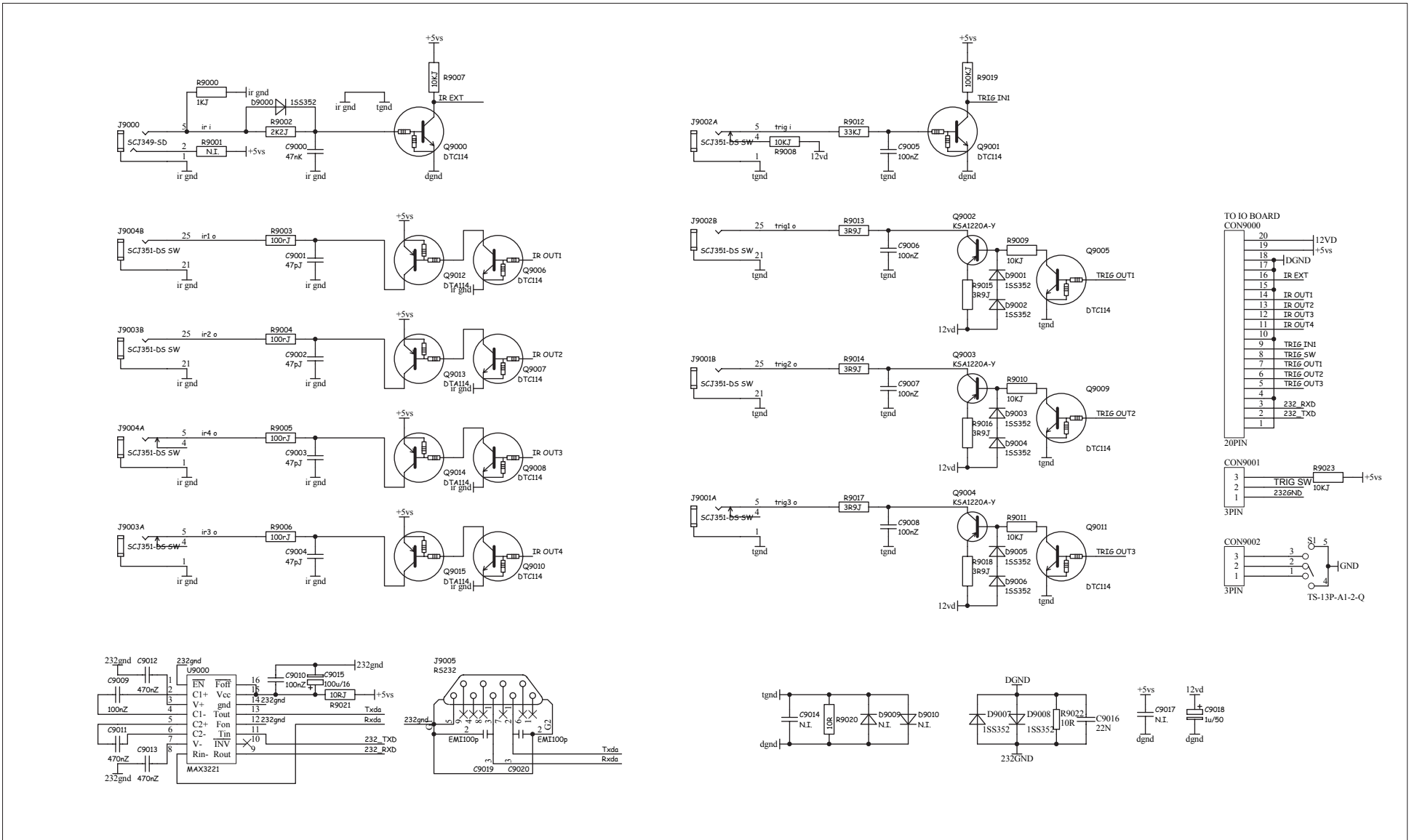

HDMI BOARD(1/16)

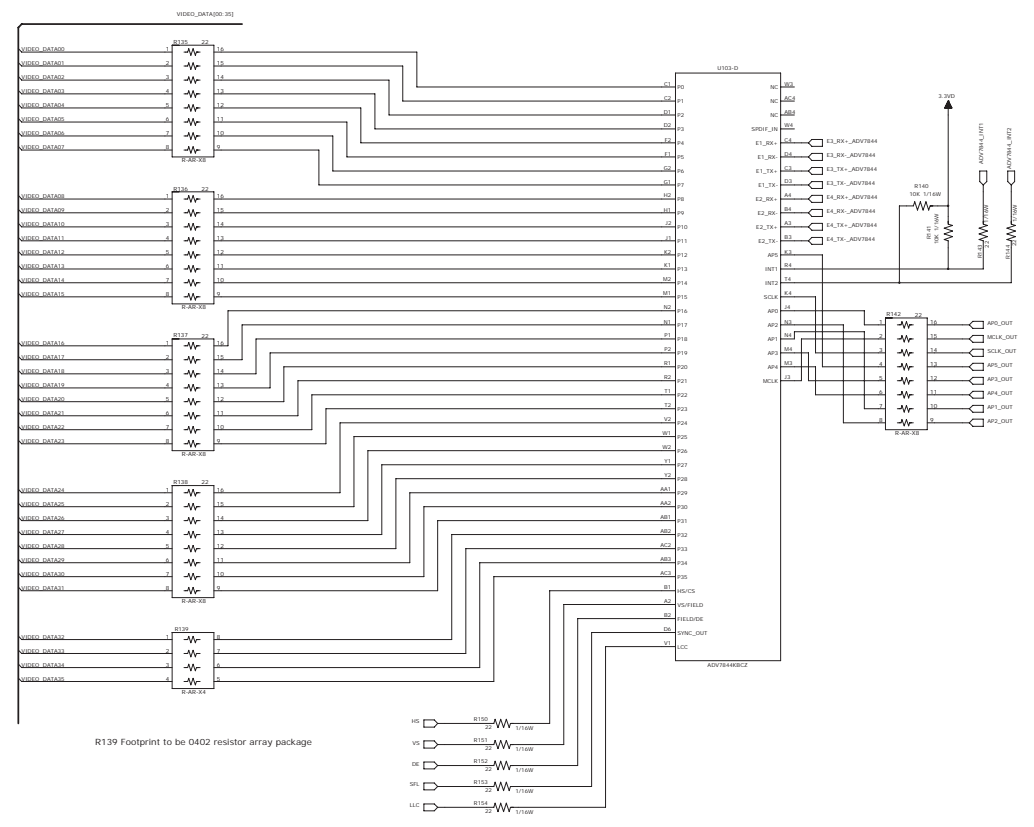
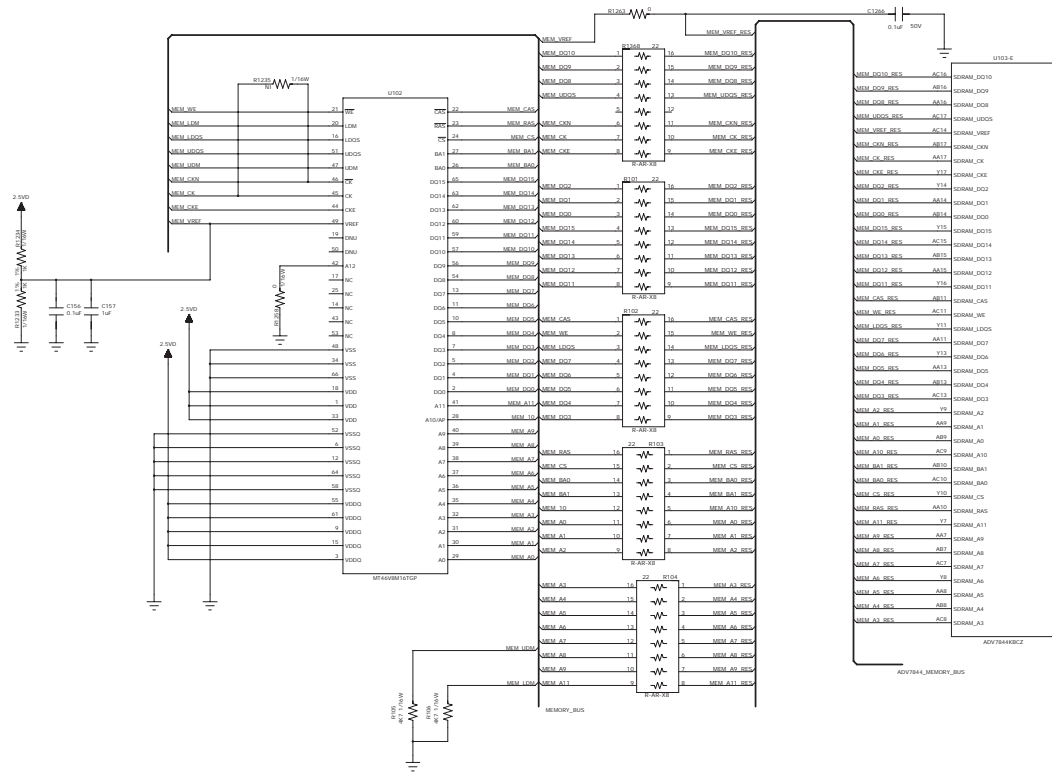

R139 Footprint to be 0402 resistor array package

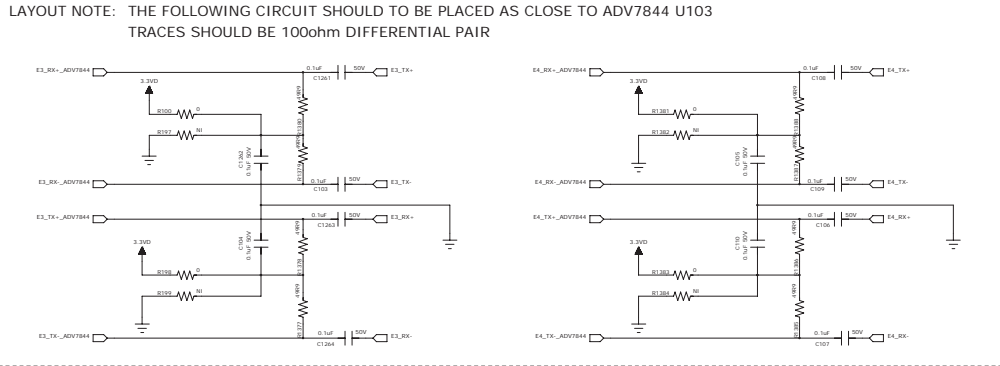

NOTE: Place Y100 as close to ADV7844 with C122 and C121 as close as possible

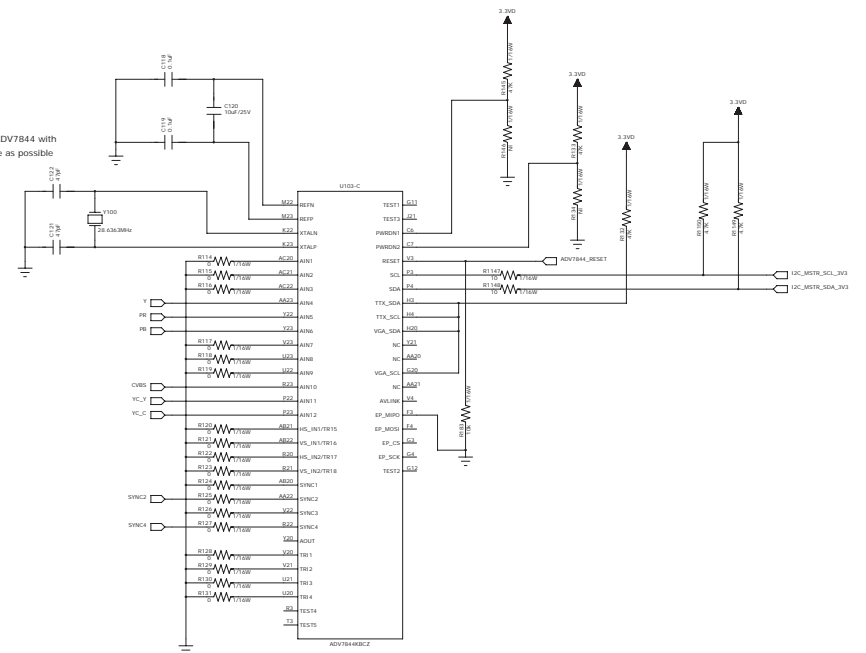

HDMI BOARD(2/16)

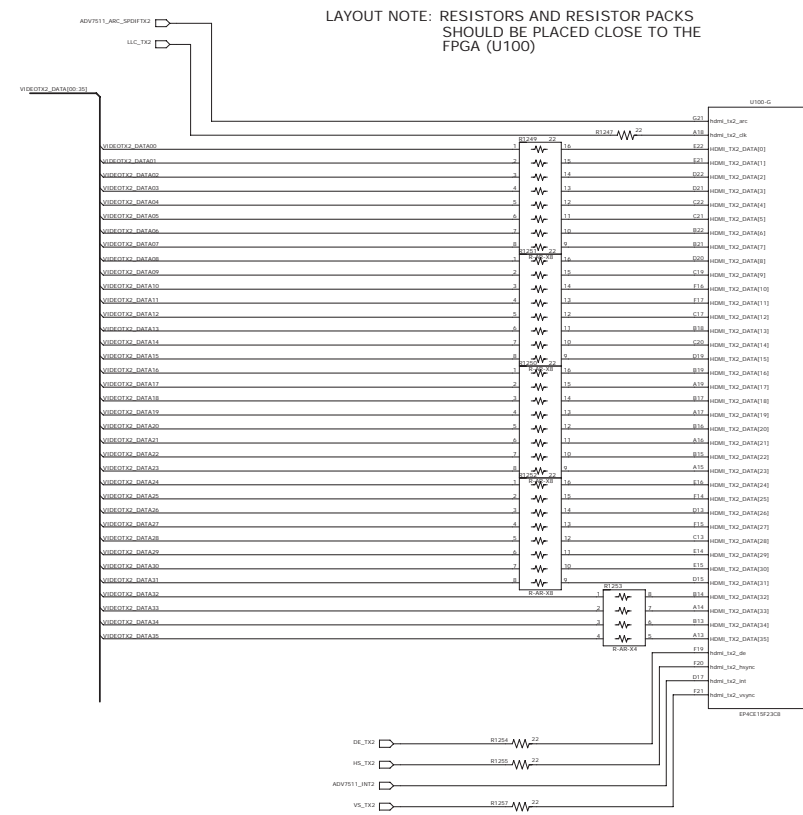
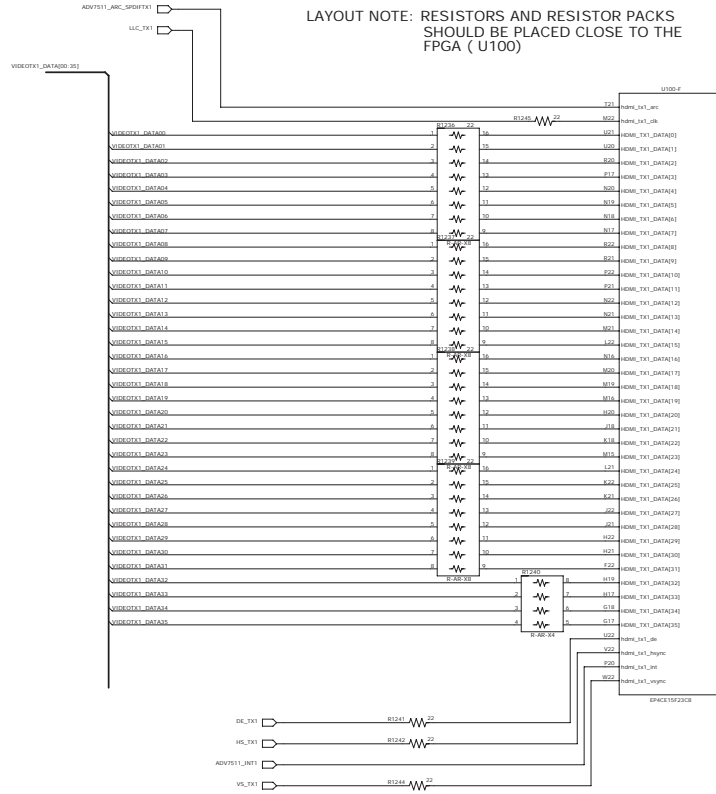

HDMI BOARD(3/16)

HDMI TRANSMITTER

HDMI OUT 1

HDMI OUT 2

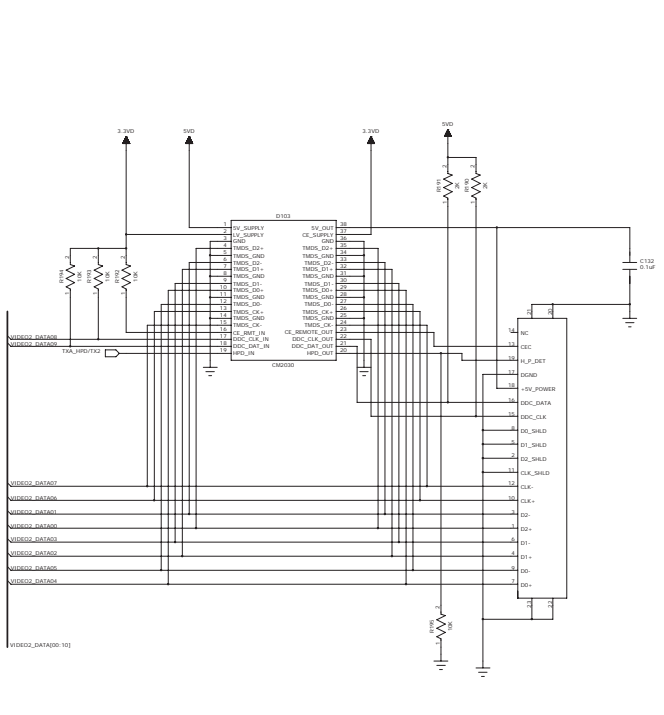
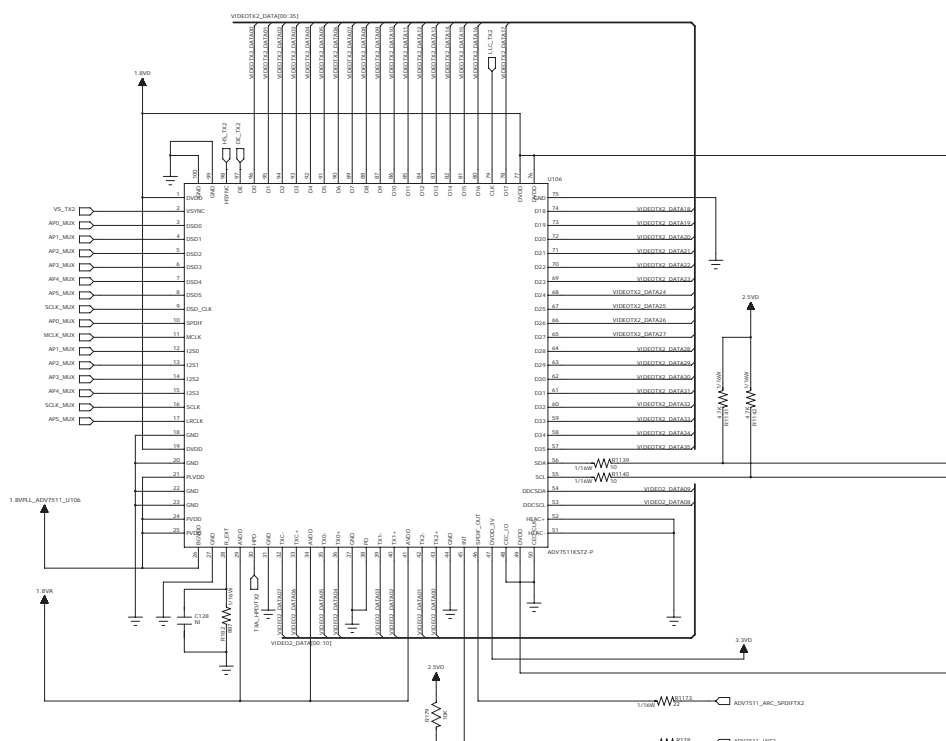
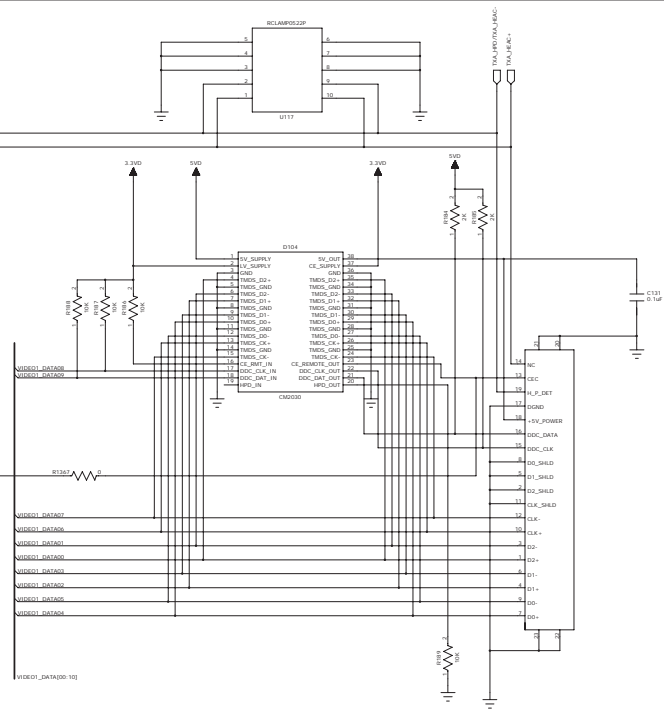
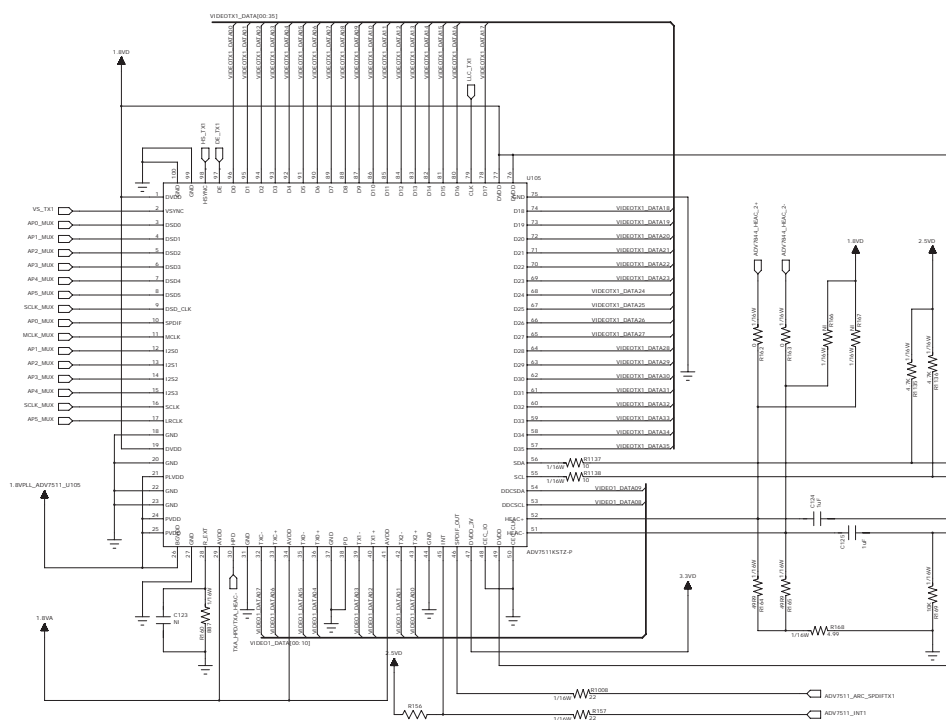

HDMI BOARD(4/16)

EDGE CONNECTOR

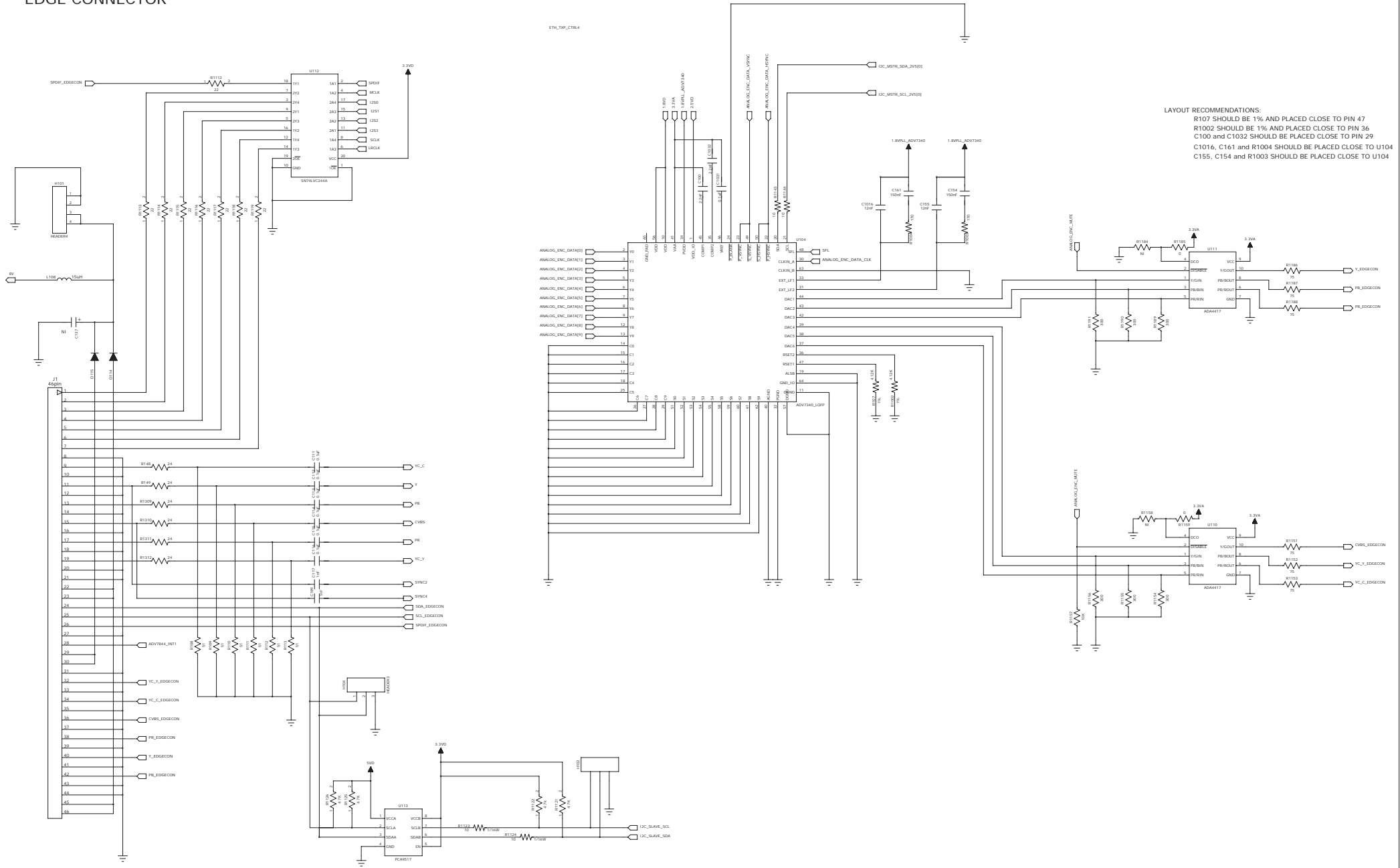

HDMI BOARD(5/16)

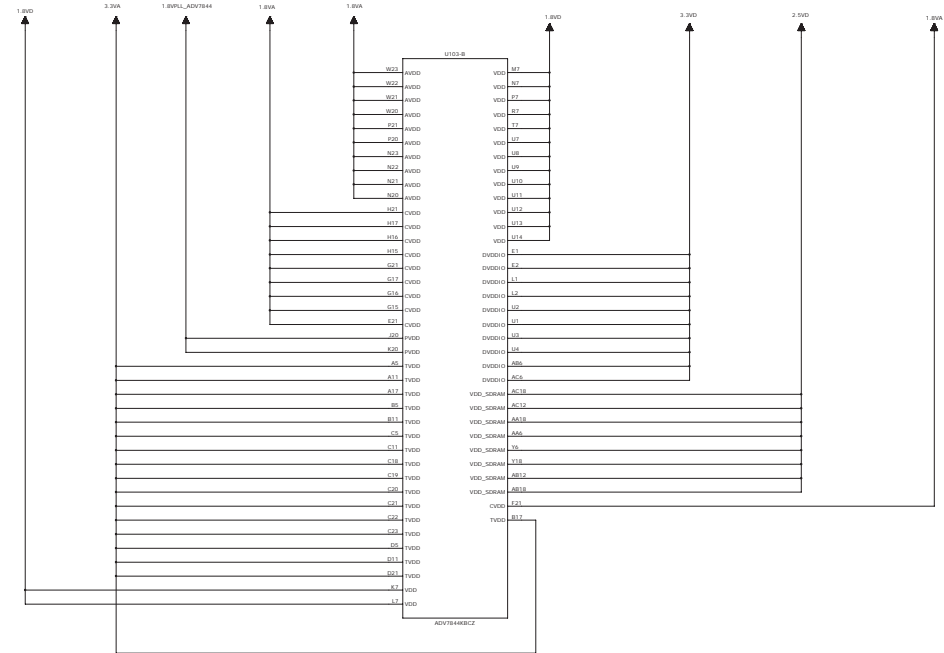
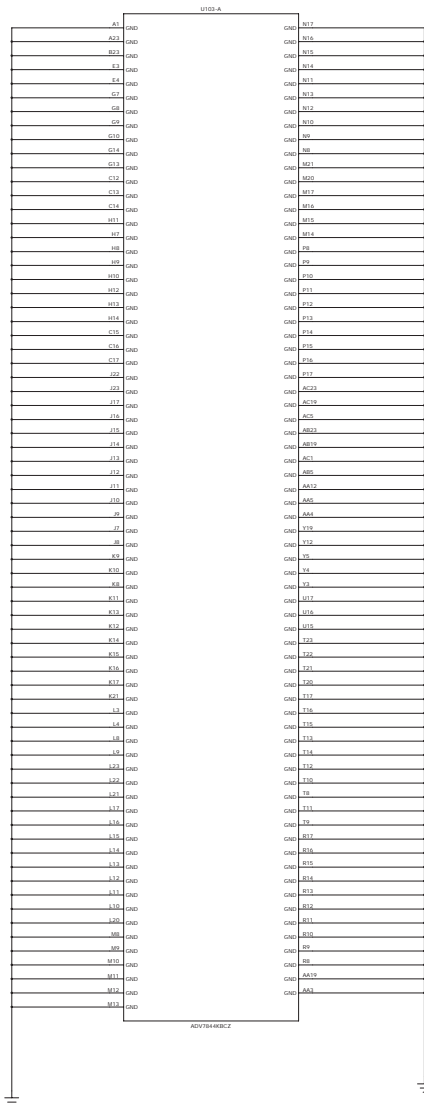

HDMI BOARD(6/16)

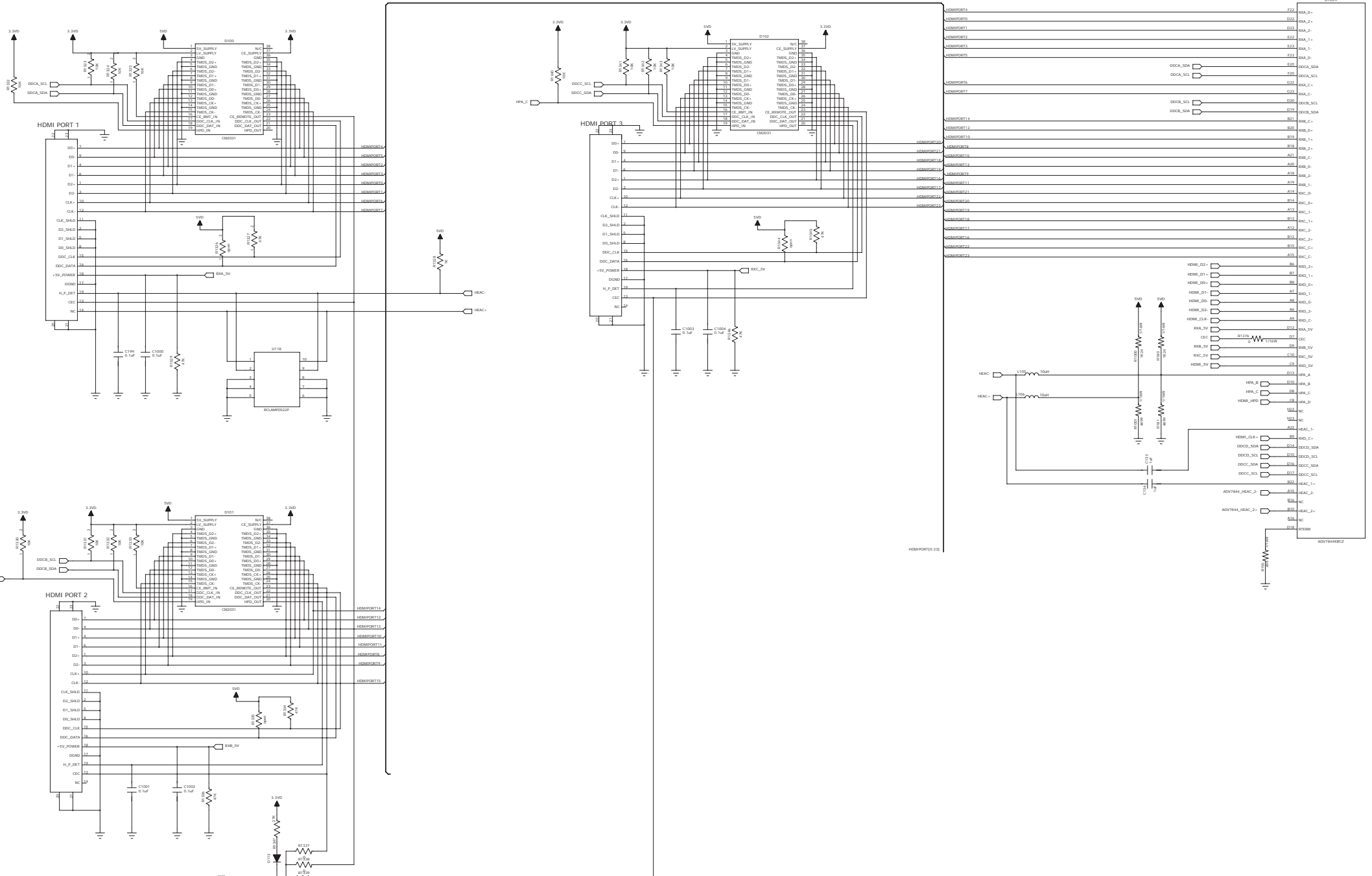

HDMI BOARD(7/16)

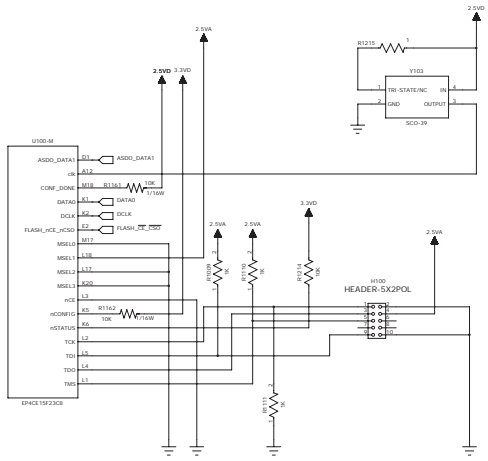

U100-E

APL_OUT	E12	VIDEO_RK_AUDIO10
APL_OUT	E12	VIDEO_RK_AUDIO10
APL_OUT	E13	VIDEO_RK_AUDIO11
APL_OUT	E13	VIDEO_RK_AUDIO11
APL_OUT	E14	VIDEO_RK_AUDIO12
APL_OUT	E14	VIDEO_RK_AUDIO12
APL_OUT	E15	VIDEO_RK_AUDIO13
APL_OUT	E15	VIDEO_RK_AUDIO13
APL_OUT	E16	VIDEO_RK_AUDIO14
APL_OUT	E16	VIDEO_RK_AUDIO14
MCLK_OUT	H12	VIDEO_RK_AUDIO15
ILIC	H11	VIDEO_RK_AUDIO16
VIDEO_DATA00	E4	VIDEO_RK_DATA00
VIDEO_DATA01	E4	VIDEO_RK_DATA01
VIDEO_DATA02	E7	VIDEO_RK_DATA02
VIDEO_DATA03	C7	VIDEO_RK_DATA03
VIDEO_DATA04	B7	VIDEO_RK_DATA04
VIDEO_DATA05	A7	VIDEO_RK_DATA05
VIDEO_DATA06	D8	VIDEO_RK_DATA06
VIDEO_DATA07	D8	VIDEO_RK_DATA07
VIDEO_DATA08	D8	VIDEO_RK_DATA08
VIDEO_DATA09	C8	VIDEO_RK_DATA09
VIDEO_DATA10	B8	VIDEO_RK_DATA10
VIDEO_DATA11	A8	VIDEO_RK_DATA11
VIDEO_DATA12	A8	VIDEO_RK_DATA12
VIDEO_DATA13	H9	VIDEO_RK_DATA13
VIDEO_DATA14	A4	VIDEO_RK_DATA14
VIDEO_DATA15	D9	VIDEO_RK_DATA15
VIDEO_DATA16	H9	VIDEO_RK_DATA16
VIDEO_DATA17	H9	VIDEO_RK_DATA17
VIDEO_DATA18	H9	VIDEO_RK_DATA18
VIDEO_DATA19	A9	VIDEO_RK_DATA19
VIDEO_DATA20	H10	VIDEO_RK_DATA20
VIDEO_DATA21	H10	VIDEO_RK_DATA21
VIDEO_DATA22	D10	VIDEO_RK_DATA22
VIDEO_DATA23	F10	VIDEO_RK_DATA23
VIDEO_DATA24	F10	VIDEO_RK_DATA24
VIDEO_DATA25	D10	VIDEO_RK_DATA25
VIDEO_DATA26	H10	VIDEO_RK_DATA26
VIDEO_DATA27	H10	VIDEO_RK_DATA27
VIDEO_DATA28	D10	VIDEO_RK_DATA28
VIDEO_DATA29	H10	VIDEO_RK_DATA29
VIDEO_DATA30	A10	VIDEO_RK_DATA30
VIDEO_DATA31	H11	VIDEO_RK_DATA31
VIDEO_DATA32	H11	VIDEO_RK_DATA32
VIDEO_DATA33	E11	VIDEO_RK_DATA33
VIDEO_DATA34	F11	VIDEO_RK_DATA34
VIDEO_DATA35	E11	VIDEO_RK_DATA35
VIDEO_DATA36	A5	VIDEO_RK_DATA36
VIDEO_DATA37	D5	VIDEO_RK_DATA37
VIDEO_DATA38	H5	VIDEO_RK_DATA38
VIDEO_DATA39	H5	VIDEO_RK_DATA39
VIDEO_DATA40	B10	VIDEO_RK_DATA40
VIDEO_DATA41	A10	VIDEO_RK_DATA41
VIDEO_DATA42	H11	VIDEO_RK_DATA42
VIDEO_DATA43	E11	VIDEO_RK_DATA43
VIDEO_DATA44	F11	VIDEO_RK_DATA44
VIDEO_DATA45	E11	VIDEO_RK_DATA45
VIDEO_DATA46	A5	VIDEO_RK_DATA46
VIDEO_DATA47	D5	VIDEO_RK_DATA47
VIDEO_DATA48	H5	VIDEO_RK_DATA48
VIDEO_DATA49	H5	VIDEO_RK_DATA49
VIDEO_DATA50	A9	VIDEO_RK_DATA50
VIDEO_DATA51	H9	VIDEO_RK_DATA51
VIDEO_DATA52	H9	VIDEO_RK_DATA52
VIDEO_DATA53	D9	VIDEO_RK_DATA53
VIDEO_DATA54	A9	VIDEO_RK_DATA54
VIDEO_DATA55	H9	VIDEO_RK_DATA55
VIDEO_DATA56	F9	VIDEO_RK_DATA56
VIDEO_DATA57	F9	VIDEO_RK_DATA57
VIDEO_DATA58	D9	VIDEO_RK_DATA58
VIDEO_DATA59	H9	VIDEO_RK_DATA59
VIDEO_DATA60	E7	VIDEO_RK_DATA60
D0	B3	VIDEO_RK_AUDIO1
H0	A3	VIDEO_RK_AUDIO2
ADV7844_INT1	E11	VIDEO_RK_AUDIO3
ADV7844_INT2	E9	VIDEO_RK_AUDIO4
ADV7844_RSSET	H5	VIDEO_RK_AUDIO5
V0	D3	VIDEO_RK_AUDIO6

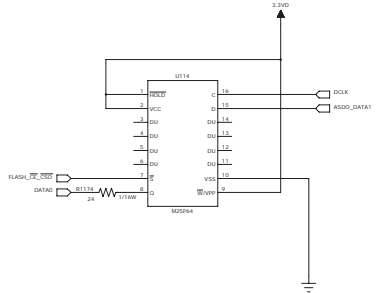

HDMI BOARD(8/16)

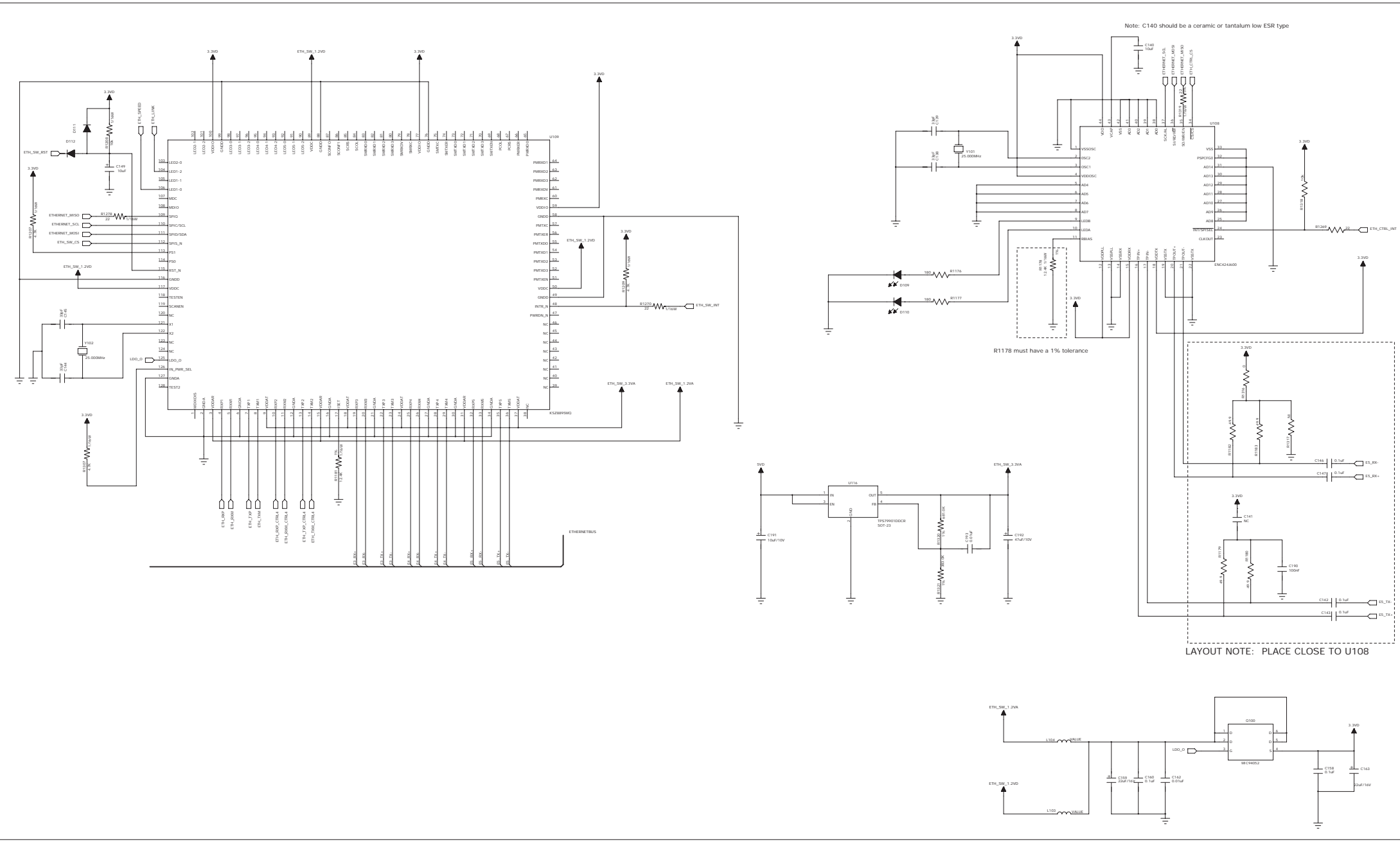

HDMI BOARD(9/16)

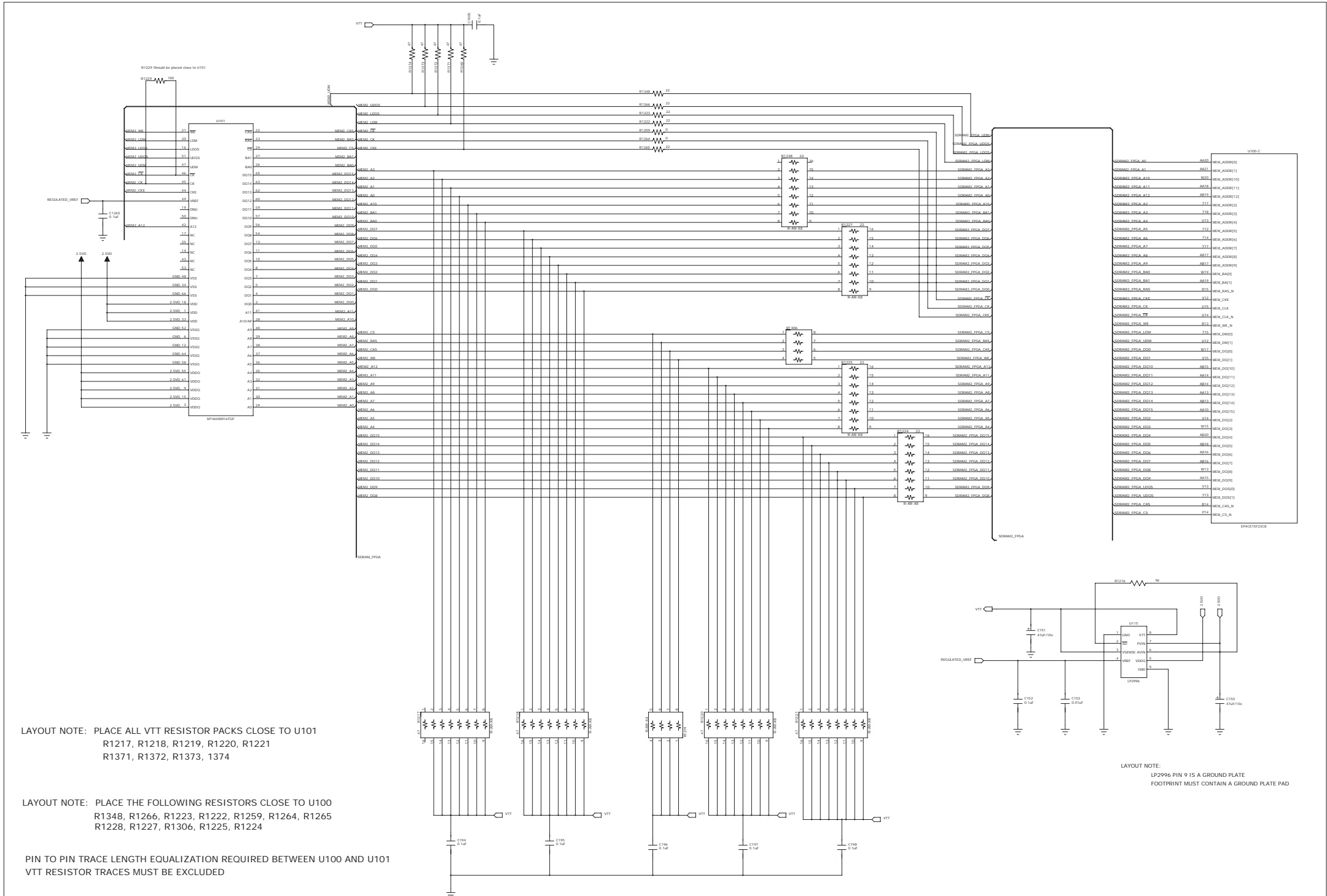

LAYOUT NOTE: PLACE ALL VTT RESISTOR PACKS CLOSE TO U101
R1217, R1218, R1219, R1220, R1221
R1371, R1372, R1373, 1374

LAYOUT NOTE: PLACE THE FOLLOWING RESISTORS CLOSE TO U100
R1348, R1266, R1223, R1222, R1259, R1264, R1265
R1228, R1227, R1306, R1225, R1224

PIN TO PIN TRACE LENGTH EQUALIZATION REQUIRED BETWEEN U100 AND U101
VTT RESISTOR TRACES MUST BE EXCLUDED

LAYOUT NOTE:
LP2996 PIN 9 IS A GROUND PLATE
FOOTPRINT MUST CONTAIN A GROUND PLATE PAD

HDMI BOARD(10/16)

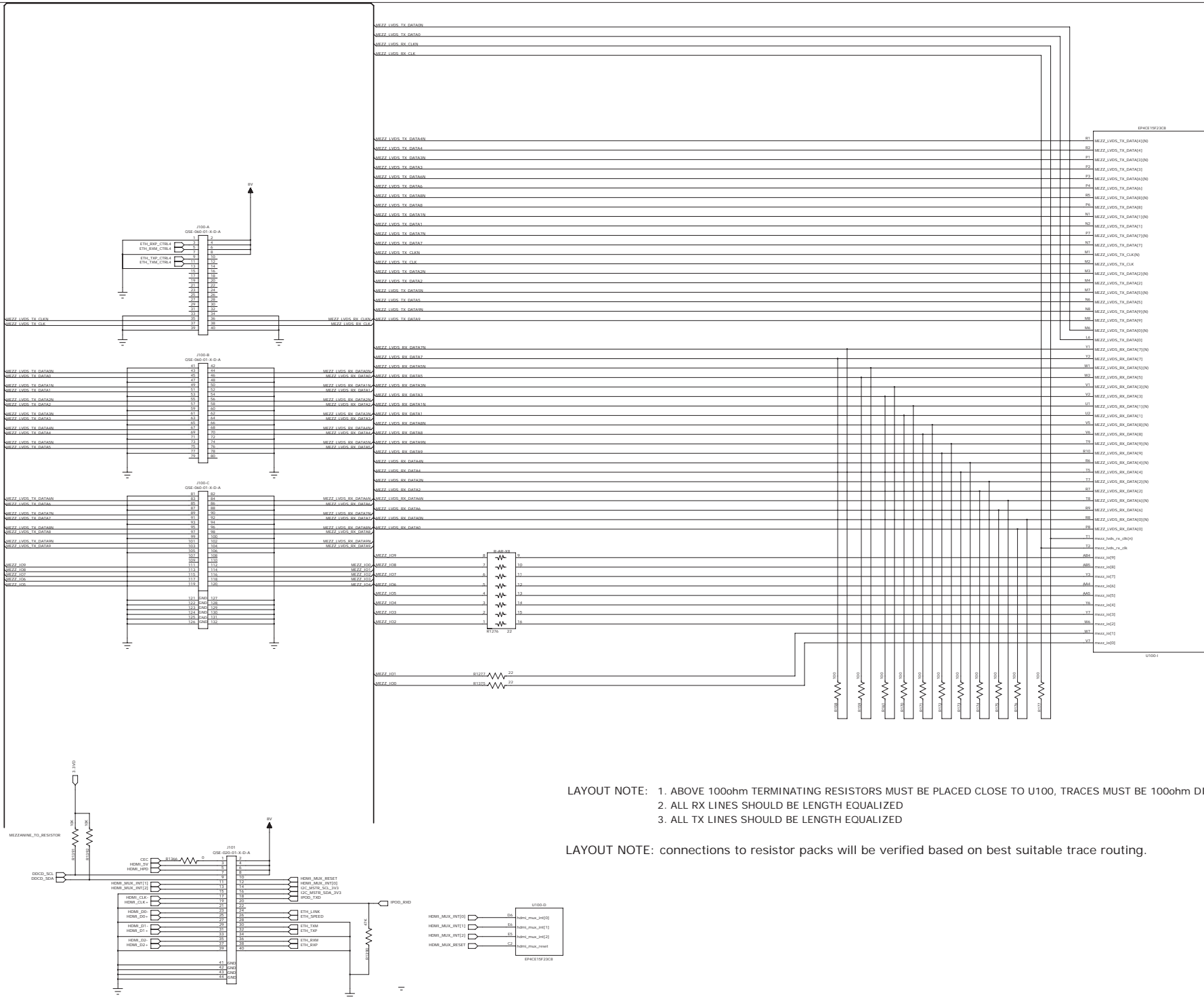

LAYOUT NOTE: 1. ABOVE 100ohm TERMINATING RESISTORS MUST BE PLACED CLOSE TO U100, TRACES MUST BE 100ohm DIFFERENTIAL PAIR
 2. ALL RX LINES SHOULD BE LENGTH EQUALIZED
 3. ALL TX LINES SHOULD BE LENGTH EQUALIZED

LAYOUT NOTE: connections to resistor packs will be verified based on best suitable trace routing.

HDMI BOARD(11/16)

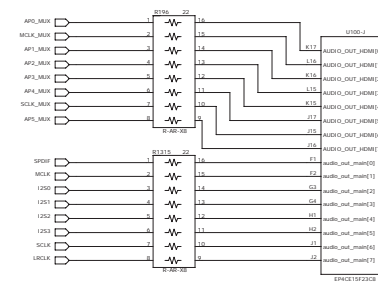
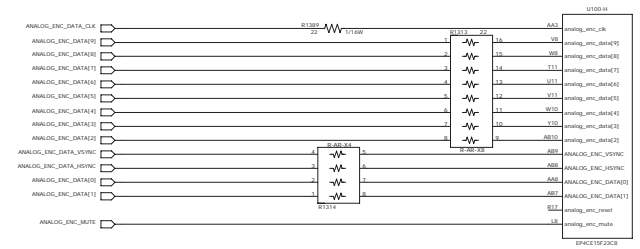
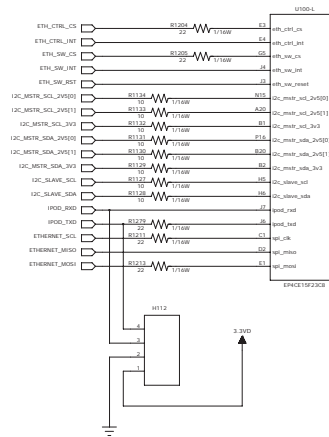
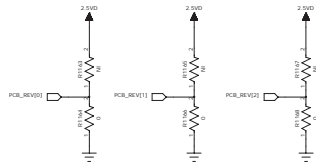
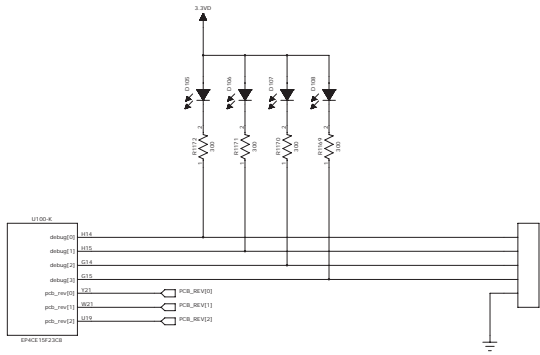

HDMI BOARD(12/16)

LAYOUT NOTE:

OVERLAY H105, H106, H107, H108, H109 ACROSS THERE ASSIGNED NET
 THESE TRACES SHOULD BE EXPOSED ON THE TOP OR BOTTOM OF THE PCB
 TRACES MUST BE VISIBLE TO ALLOW FOR POSSIBLE CUTTING.
 HEADERS TO BE USED TO MEASURE CURRENT ACROSS THESE TRACES

U119, U120, U121, U122 & U123 ALL COMPONENTS HAVE A CENTER GROUND PAD

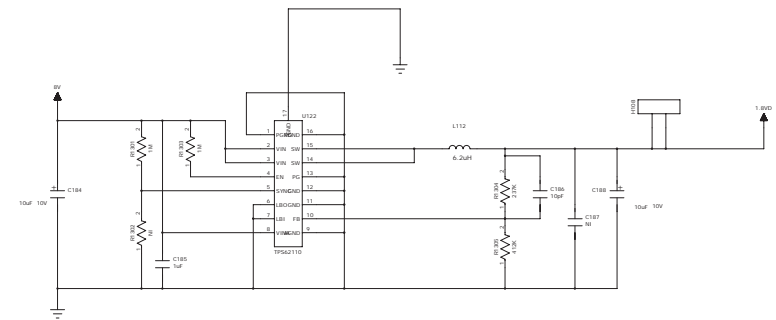
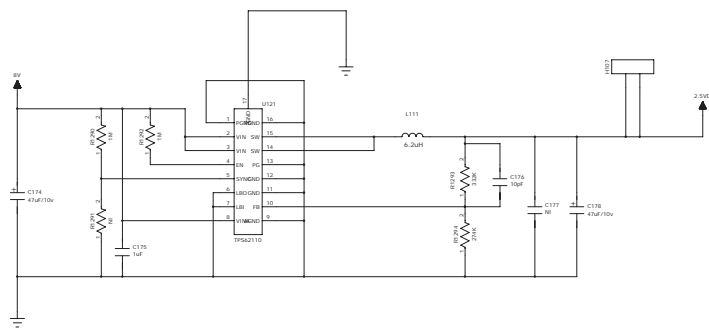
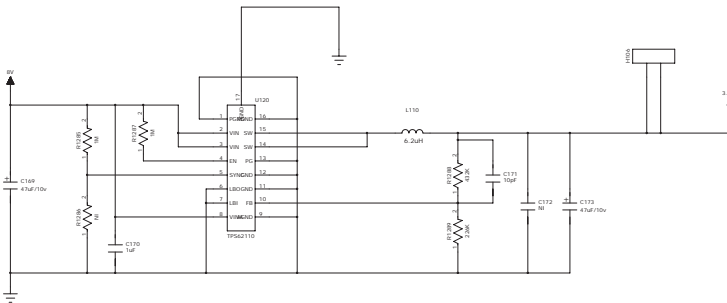
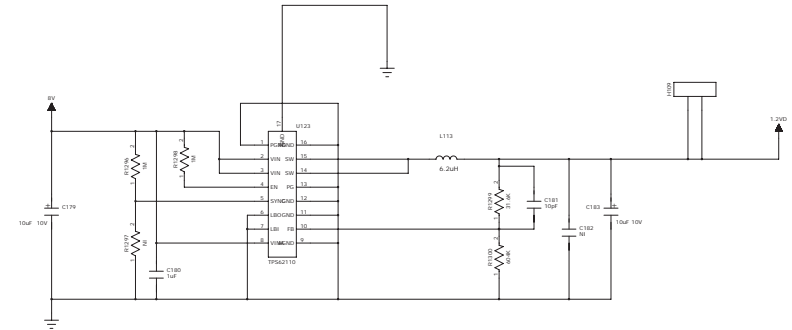
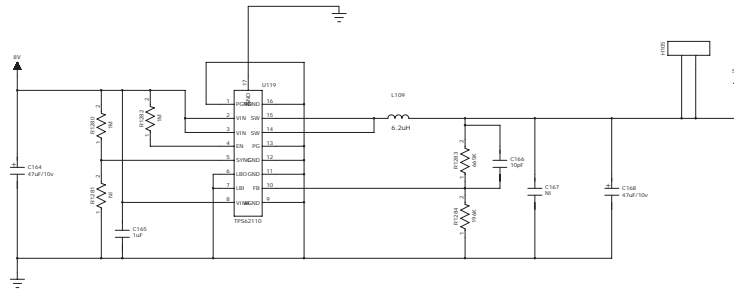

HDMI BOARD(13/16)

LAYOUT NOTE:

OVERLAY H110, H111 ACROSS THERE ASSIGNED NET
 THESE TRACES SHOULD BE EXPOSED ON THE TOP OR BOTTOM OF THE PCB
 TRACES MUST BE VISIBLE TO ALLOW FOR POSSIBLE CUTTING.
 HEADERS TO BE USED TO MEASURE CURRENT ACROSS THESE TRACES

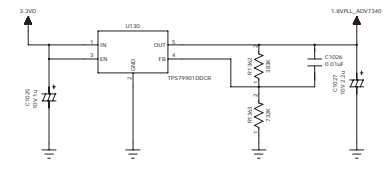
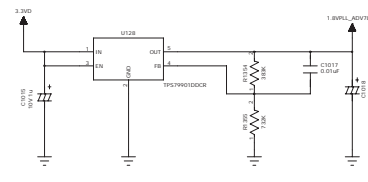
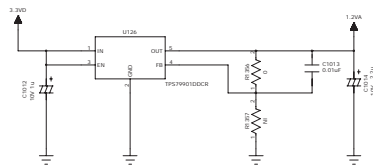
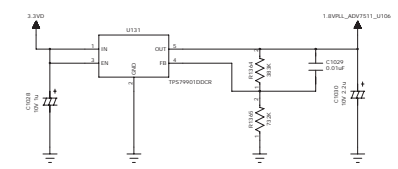
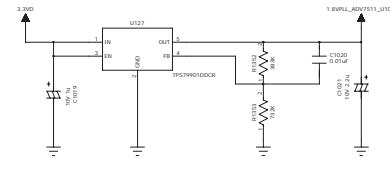
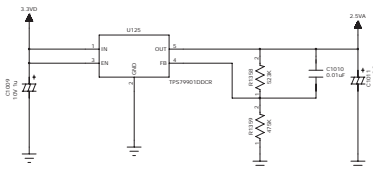
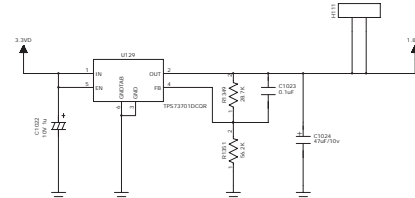
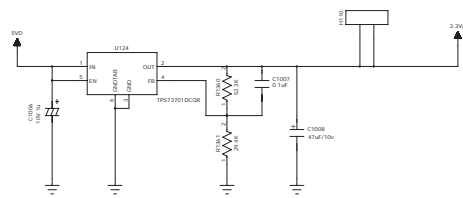

HDMI BOARD(14/16)

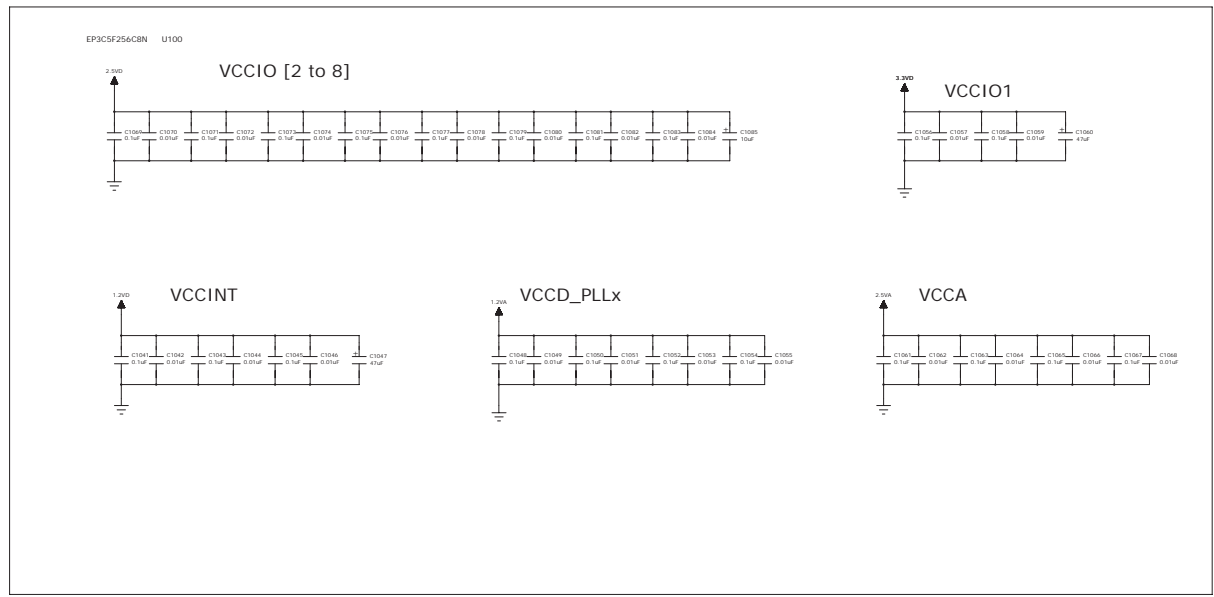
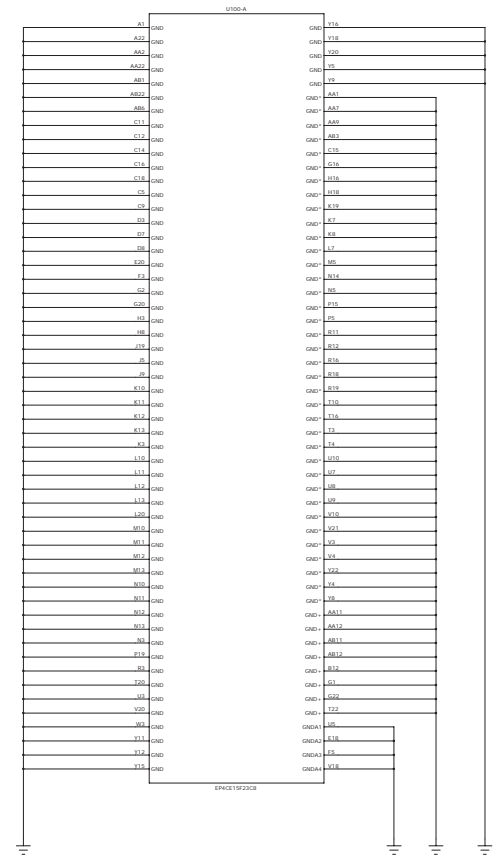
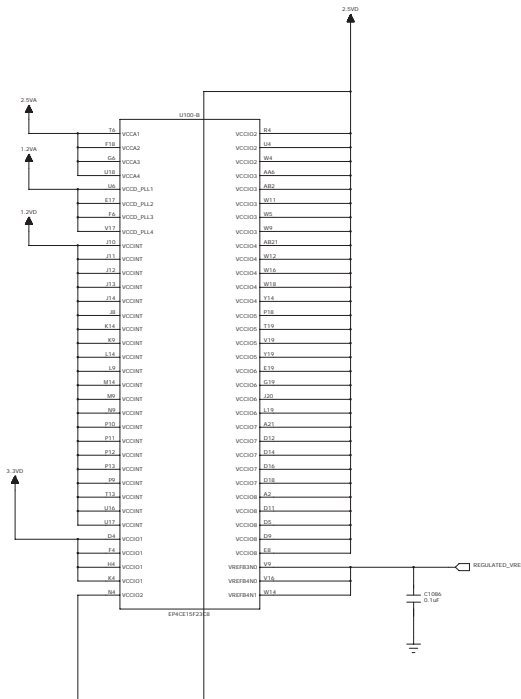

HDMI BOARD(15/16)

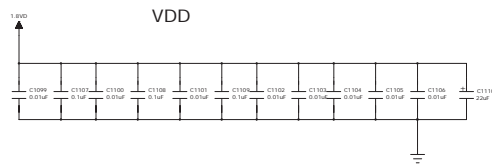
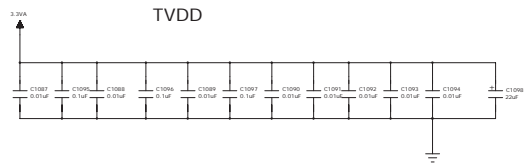

DECOUPLING ADV7844 U103

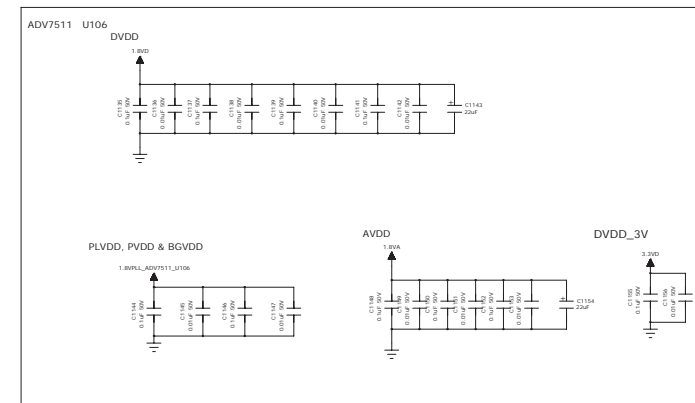
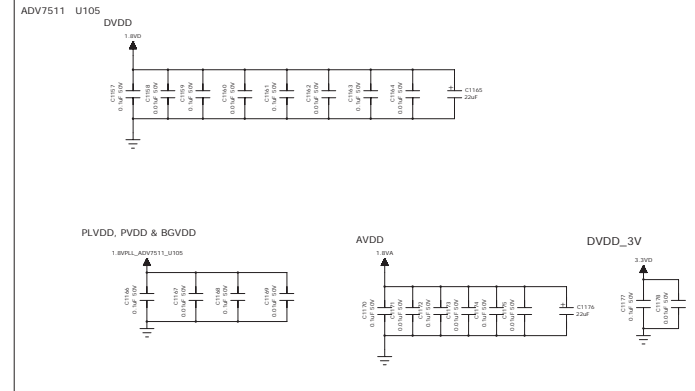
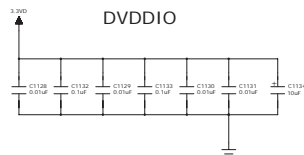
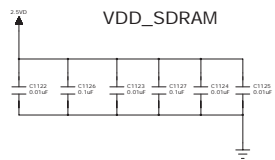
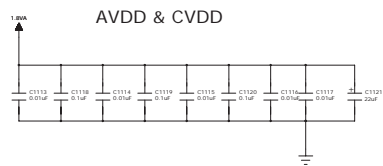
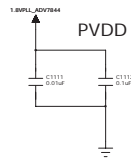

HDMI BOARD(16/16)

DECOUPLING

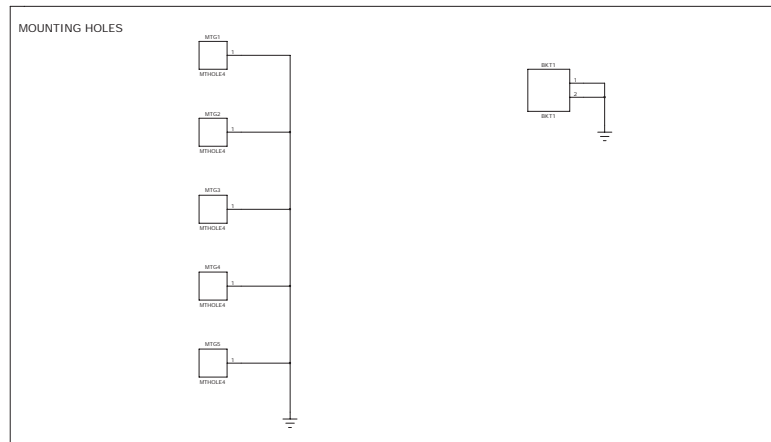
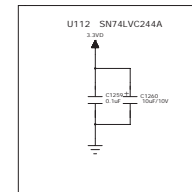
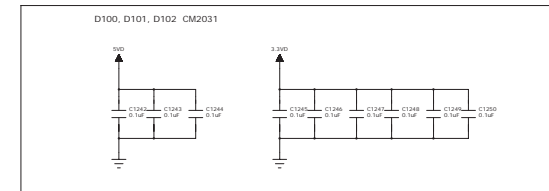
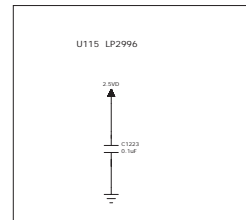
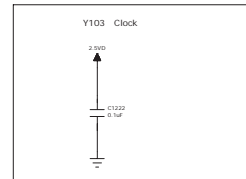
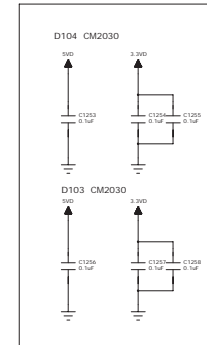
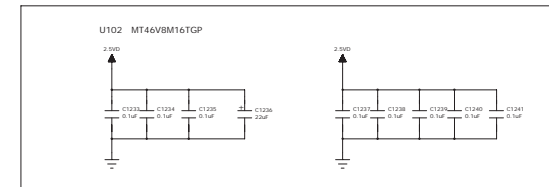
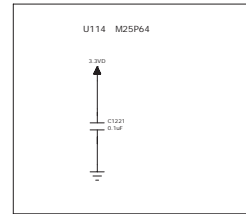
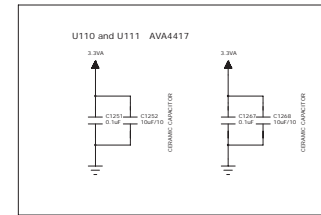
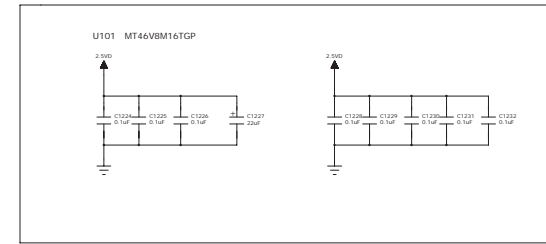
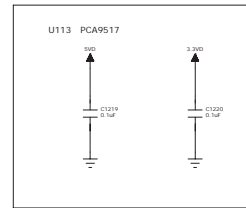
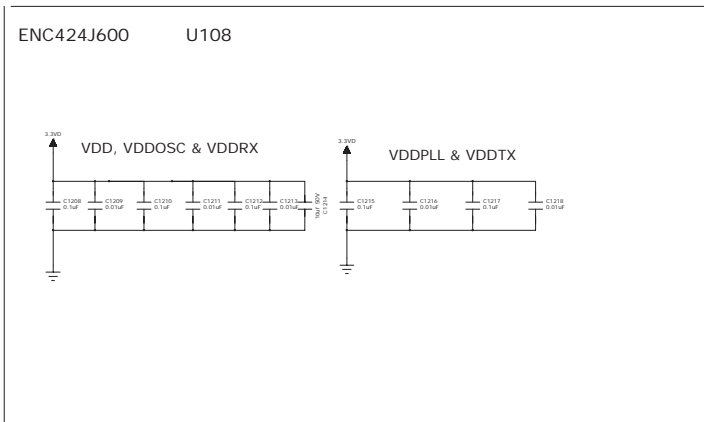
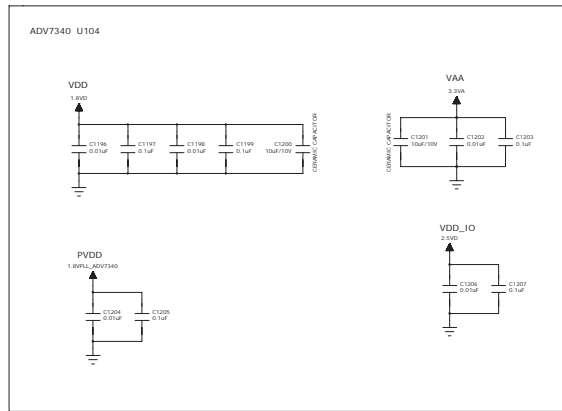
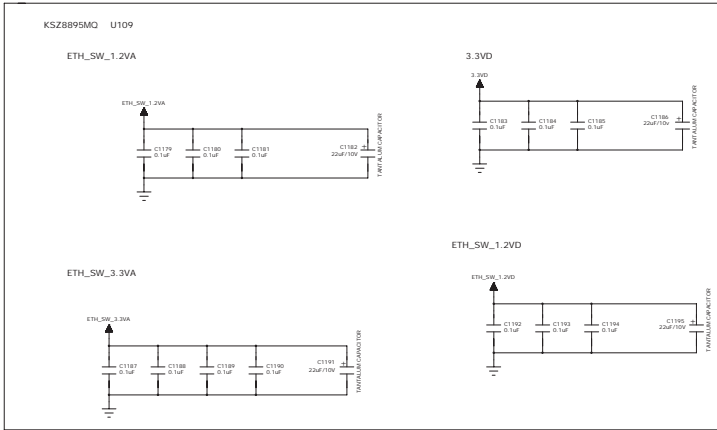

HDMI EXPANDER BOARD(1/4)

HDMI INPUT PORTS

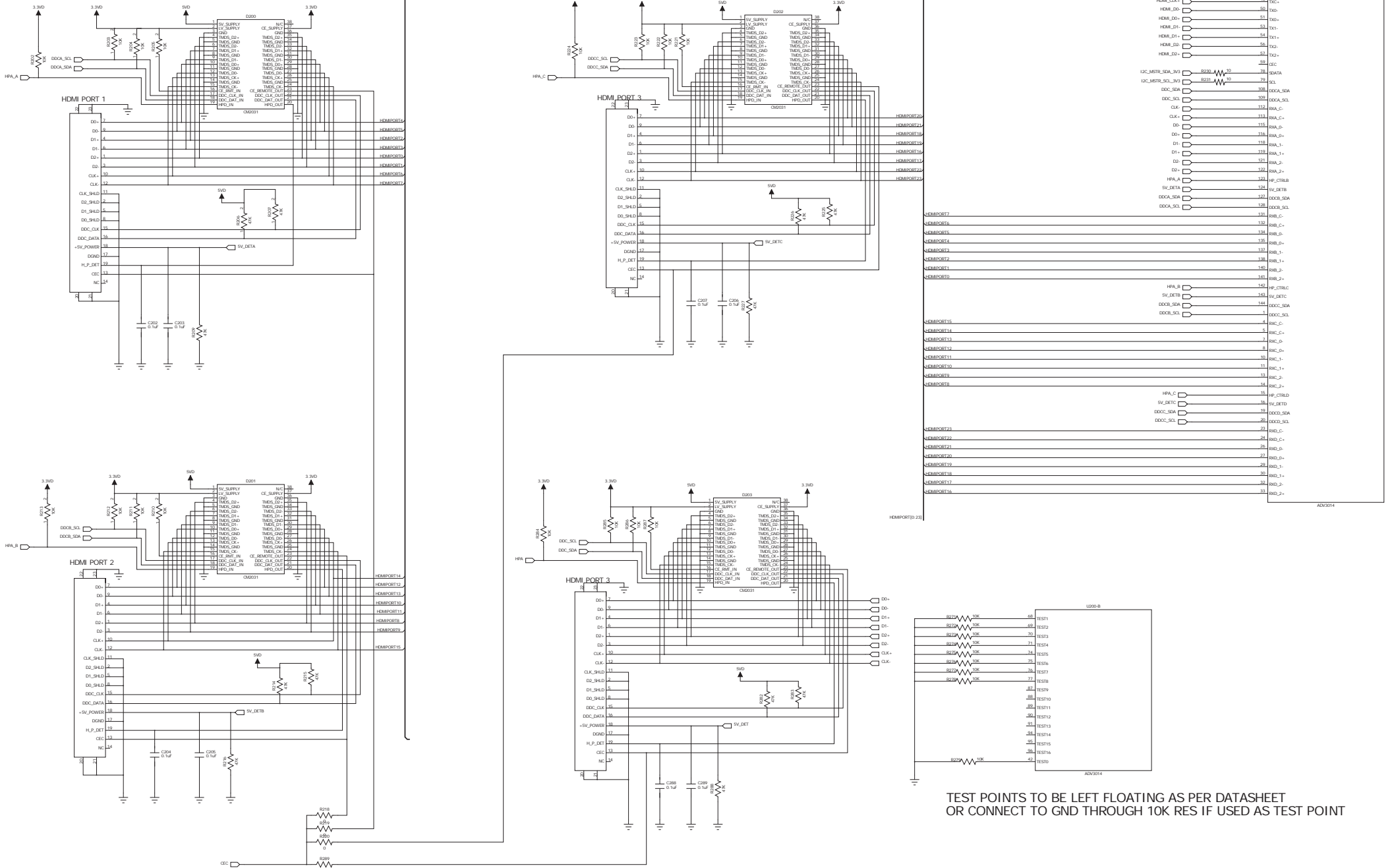

TEST POINTS TO BE LEFT FLOATING AS PER DATASHEET OR CONNECT TO GND THROUGH 10K RES IF USED AS TEST POINT

HDMI EXPANDER BOARD(2/4)

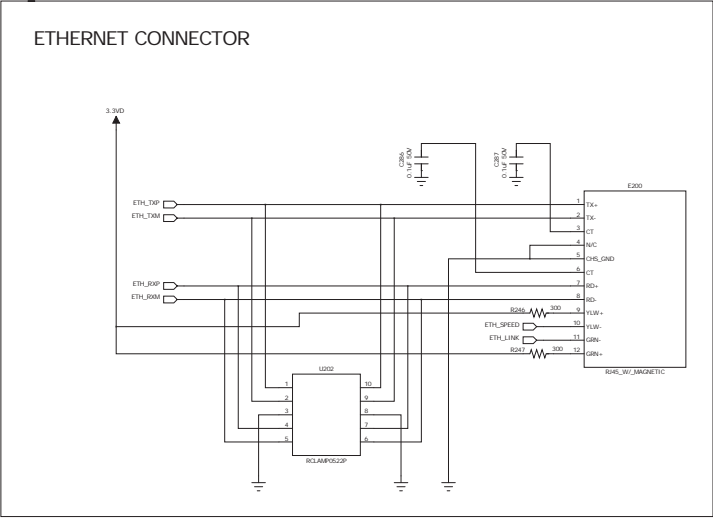
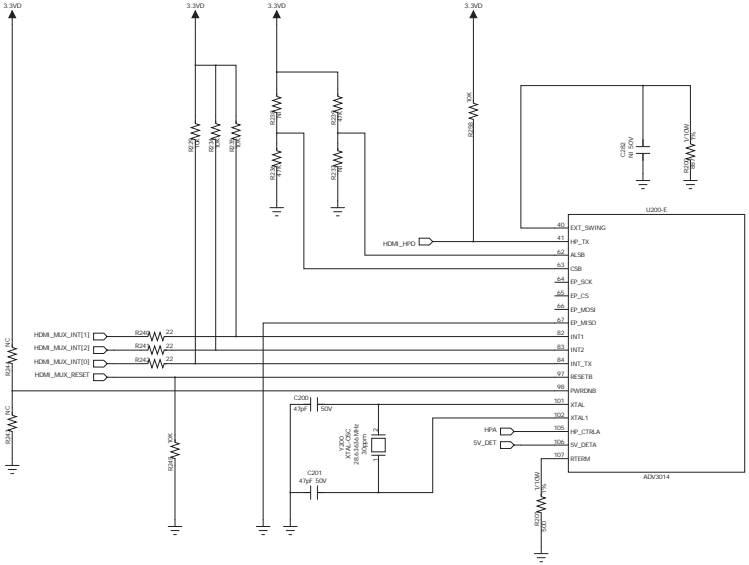
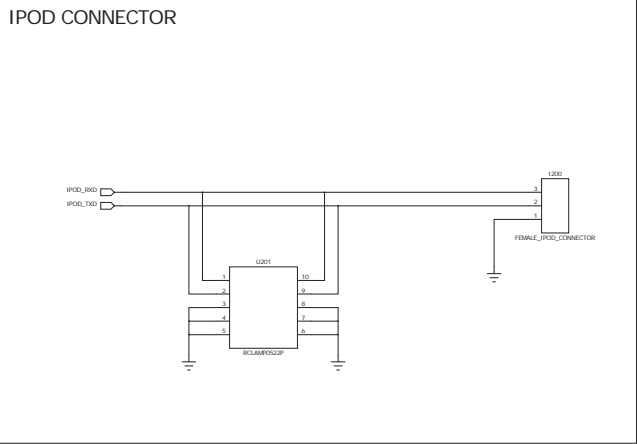
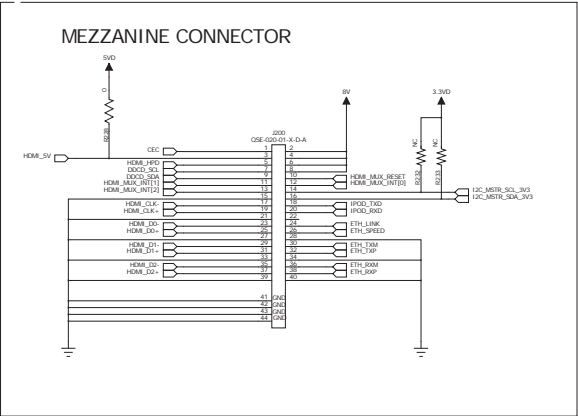

HDMI EXPANDER BOARD(3/4)

CVDD, TVDD and PVDD MUST BE FILTERED AND HAVE GOOD DECOUPLING

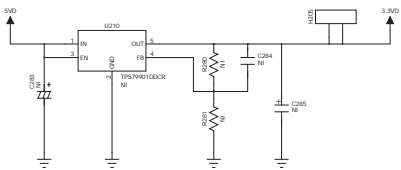
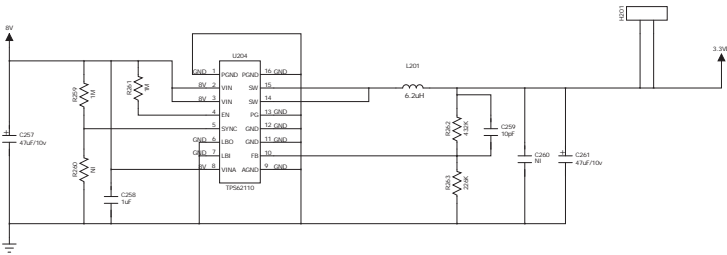
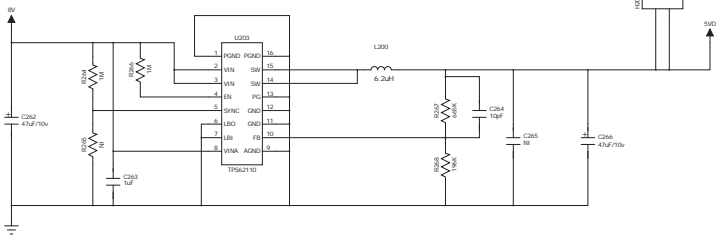
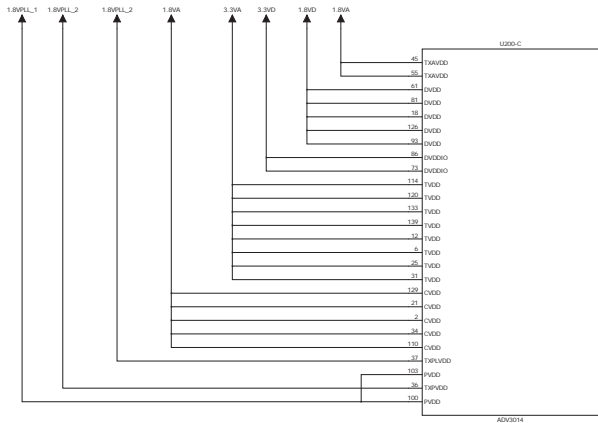
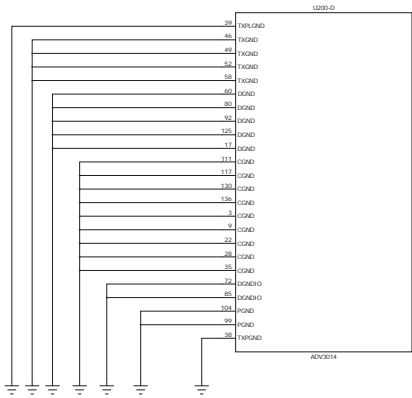

- U210 TPS79901DDCCR
- C283 1uF 10V
- C284 0.1uF 10V
- C285 47uF/10V
- R280 681K
- R281 383K

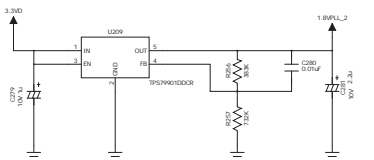
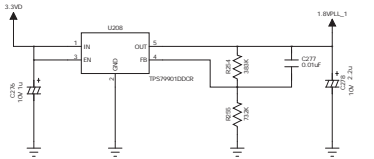
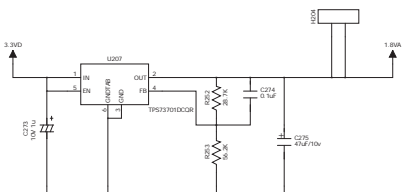
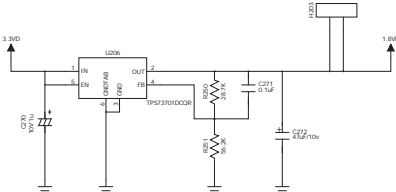
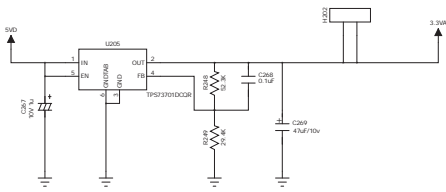

HDMI EXPANDER BOARD(4/4)

ADV3014 U200

TVDD

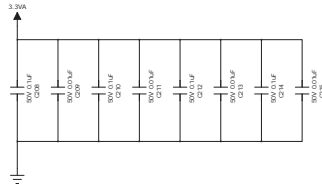

CVDD

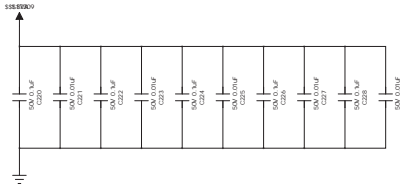

PVDD

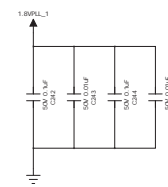

DVDD_IO

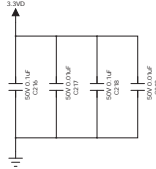

DVDD

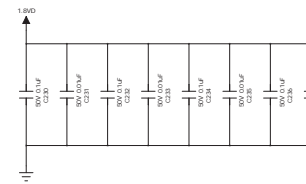

TXAVDD

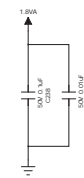

TXPVDD

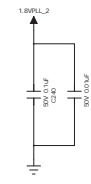

TXPLVDD

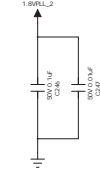

CM2031 D200, D201 AND D202

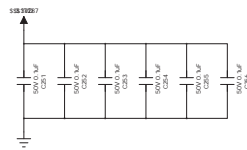
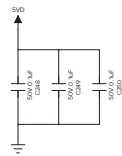

ELECTRICAL PARTS LIST

PCB-1:ANALOG BOARD			
CIRCUIT NO.	PART NO.		DESCRIPTION
	PCB INFO		
	A16-11521-21	ANALOG PCB	VM1.0, FR-4,1.6mm,1OZ,TG130, 216.57mmX164.5mm
	DIODES		
D1000, D1011, D1012, D1013, D1014, D1015, D1016, D1017, D1018, D1023, D1024, D1025, D1026, D1027, D1028, D1029, D1030, D1031, D1032, D1033, D1058, D1059	33-40352-01	Switch Diode	1SS352(TPH3,F)
D1001, D1002,D1060,D1061,D1062,D1063	33-40054-00	Schottky Diode	BAT54S, SOT23
D1034, D1035, D1036	33-20004-02	Surface Mount Rectifier	M4A,SMA,Tape
D1037, D1038, D1045, D1049, D1050, D1051, D1052, D1053, D1054, D1055, D1056, D1057	33-11200-11	Zener Diode SMD	12V,1/2W, LL34
D1201	33-44148-17	Switch Diode SMD	1N4148W-NR
	TRANSISTORS		
Q1000, Q1010, Q1011, Q1017, Q1028, Q1029, Q1030, Q1031, Q1032, Q1033,Q1034,Q1039	31-03326-01	Transistor	2SC3326A
Q1018, Q1019, Q1020, Q1021, Q1022, Q1035, Q1202	31-00114-01	Transistor	DTA114, SOT23, Tape
Q1023, Q1024, Q1025, Q1026, Q1027,Q1036, Q1204	31-00114-05	Transistor	DTC114, SOT23, Tape
Q1201	31-01815-03	Transistor	C1815
	IC		
U1000	03-00595-01	Shift Registers	74HC595, SOIC0.15inch, Tube/Tape
U1013	03-01780-01	Audio Digital-to-Analog Converter	PCM1780
U1015, U1045	03-00734-01	Buffer	NC7NZ34K8X
U1052, U1053, U1054, U1055, U1056	03-00716-01	Buffer	NC7WZ16P6X
U1057, U1058	03-07125-01	Buffer	NC7SZ125P5X
U1020, U1021, U1022	03-00138-05	Line Decoder	74HC138D
U1020, U1021, U1022	03-00138-02	Line Decoder	74HC138, SOIC0.15inch, Tube/Tape
U1024	03-01117-01	Linear Regulator	LM1117MPX-5.0/AMS1117-5.0
U1001, U1023	03-01117-33	Linear Regulator	LM1117MPX-3.3/AMS1117-3.3
U1026, U1032, U1033, U1034, U1035, U1036, U1037, U1038, U1046, U1201	03-02114-01	Dual OPAMP	NJM2114M-TE2,DMP8
U1027	03-02134-00	Dual OpAmp	OPA2134UA, SOIC0.15inch, Tube/Tape
U1028,U1031	03-05532-03	Dual OPAMP	NE5532DR SOIC8
U1029, U1030, U1039	03-02082-01	Dual OpAmp	NJM2082MD-TE2
U1040	03-09488-01	Analog Switch	TC94A88FG(BH,DRY)
U1044	03-00082-02	Dual OpAmp	TL082CD
U1048	03-04202-01	ADC	PCM4202
U1051	03-61545-01	Serial Data Control Dual Electronic Volume	M61545AFP
U1005	03-00317-03	3-Terminal Regulator	LM317EMP,SOT-223
	CAPACITOR		
C1358, C1359, C1360, C1361	26-10051-00	Chip capacitor	10PJ,50V,0603,NPO
C1416, C1417	26-22051-00	Chip capacitor	22P,0603,50V,NPO
C1202	26-33051-00	Ceramic Chip Capacitor	33pJ,50V,0603,NPO
C1201, C1203, C1207	26-10151-00	Ceramic Chip Capacitor	100pJ,50V,0603,NPO
C1418, C1419	26-22151-00	Ceramic Chip Capacitor	220pJ,50V,0603,NPO
C1030, C1032, C1033	26-33151-00	Multilayer Ceramic CAP	330PJ,50V,0603,NPO
C1293, C1294, C1295, C1296	26-56151-00	Multilayer Ceramic CAP	560pJ,50V,0603,NPO
C1002, C1003, C1004, C1022, C1023, C1029, C1158, C1171, C1403	26-10251-10	Multilayer Ceramic CAP	1nJ,50V,0603,NPO
C1206	26-10351-00	Ceramic Chip Capacitor	10nK,50V,0603,X7R
C1001, C1010, C1011, C1012, C1013, C1014, C1015, C1017, C1024, C1025, C1027, C1031, C1037, C1052, C1065, C1105, C1106, C1107, C1108, C1111, C1112, C1113, C1116, C1117, C1118, C1119, C1124, C1125, C1126, C1127, C1128, C1129, C1131, C1132, C1133, C1134, C1135, C1136, C1137, C1138, C1139, C1140, C1141, C1150, C1151, C1152, C1153, C1154, C1155, C1156, C1157, C1159, C1160, C1170, C1208, C1209, C1312, C1313, C1314, C1329, C1352, C1353, C1356, C1357, C1363, C1364, C1365, C1414, C1415	26-10451-10	Multilayer Ceramic CAP	100nK,50V,0603,X7R

C1235, C1236, C1237, C1238, C1239, C1240, C1241, C1242, C1243, C1244, C1245, C1246, C1261, C1262	26-18151-01	Multilayer Ceramic CAP	180PJ,50V,0805,NPO
C1270, C1271, C1272, C1276, C1277, C1285, C1289, C1290, C1291, C1292, C1362, C1304, C1305, C1306, C1307, C1308, C1309	26-22151-01	Multilayer Ceramic CAP	220PJ,50V,0805,NPO
C1193, C1194	26-27151-11	Multilayer Ceramic CAP	270pJ, 50V, NPO, 0805
C1259, C1260, C1263, C1266, C1267, C1269	26-10251-11	Multilayer Ceramic CAP	1nJ,50V,0805,NPO
C1191, C1192	26-27251-01	Multilayer Ceramic CAP	2n7K,50V,0805,X7R
C1310, C1311	26-10351-01	Multilayer Ceramic CAP	10nK,50V,0805,X7R
C1021, C1026, C1028, C1043, C1050, C1053, C1057, C1058, C1059, C1060, C1062, C1063, C1066, C1069, C1070, C1071, C1072, C1073, C1074, C1076, C1077, C1078, C1079, C1080, C1348, C1349, C1400, C1412, C1413,	26-10451-11	Multilayer Ceramic CAP	100NK,50V,0805,X7R
C1020	26-22511-01	Ceramic Chip Capacitor	2.2uF
C1401	26-22660-11	Chip capacitor	22U/6V3 X5R 0805
C1350, C1351, C1354, C1355	06-10011-11	Chip Tan capacitor	TPSA106M010R0900
C1180, C1181, C1182, C1330	27-10160-00	Tan Electrolytic Capacitor	100UF,6.3V,
C1161, C1162, C1163, C1164, C1178	06-22021-00	ALU Electrolytic CAP	CD110,22uF,25V,±20%,F2.5
C1016, C1018, C1035, C1036, C1233	06-33011-00	Alu Electrolytic Capacitor	CD11C,33uF,16V,±20%,F2.5
C1331, C1332, C1187, C1188, C1189, C1190, C1204, C1205	06-47011-08	ALU Electrolytic CAP	CD11A,47uF,16V,ELNA,F2.5
C1335, C1336, C1337	06-10211-04	ALU Electrolytic CAP	CD263,1000uF,16V,±20%,10×16,F5.0
C1195, C1196, C1211, C1212, C1213, C1214, C1215, C1216, C1217, C1218, C1219, C1220, C1221, C1222, C1223, C1224, C1225, C1226, C1227, C1228, C1333, C1334, C1410, C1411	06-22011-04	ALU Electrolytic CAP	CD71,22uF,16V,±20%,D=5,F2.5
C1034, C1082, C1083, C1169	06-33121-00	ALU Electrolytic CAP	CD263X,330uF,25V,±20%,F5.0
C1234, C1229	06-47111-09	ALU Electrolytic CAP	CD263,470uF,10V
	RESISTOR		
R1023, R1024, R1132	07-90820-00	Chip Resistor	82R,0603,1/10W,±5%
R1067, R1068, R1069, R1070, R1071, R1072, R1095, R1096, R1133, R1134, R1143, R1459, R1460, R1461	07-90101-00	Chip Resistor	100R,0603,1/10W,±5%
R1462 R1463	07-98870-00	Chip Resistor	887R,0603,1/10W,±1%
R1208	07-90102-00	Chip Resistor	1KΩ,0603,1/10W,±5%
R1204	07-92201-00	Chip Resistor	2.2KΩ,0603,1/10W,±1%
R1210	07-90222-00	Chip Resistor	2.2KΩ,0603,1/10W,±5%
R1043, R1050	07-92431-00	Chip Resistor	2.43KΩ,1/10W,±1%,RC0603FR-072K43L
R1044, R1045, R1046, R1047, R1049, R1197	07-92611-00	Chip Resistor	2.61KΩ,0603,1/10W,±1%,RC0603
R1206, R1207, R1464 R1465	07-94701-00	Chip Resistor	4.7KΩ,0603,1/10W,±1%
R1088, R1113, R1193, R1194	07-96801-00	Chip Resistor	6.8KΩ,0603,1/10W,±1%
R1168, R1169, R1202	07-91002-00	Chip Resistor	10KΩ,0603,1/10W,±1%
R1209	07-91802-00	Chip Resistor	18KΩ,0603,1/10W,±1%
R1205, R1466, R1467	07-90223-00	Chip Resistor	22KΩ,0603,1/10W,±5%
R1201	07-90333-00	Chip Resistor	33KΩ,0603,1/10W,±5%
R1203	07-90433-00	Chip Resistor	43KΩ,0603,1/10W,±5%
R1458	07-90000-01	Chip Resistor	0Ω,0805,1/8W,±5%
R1457	07-90100-01	Chip Resistor	10R,0805,1/8W,±5%
R1431, R1432, R1433, R1434, R1435, R1436	07-90470-01	Chip Resistor	47R,0805,1/8W,±5%
R1365, R1366, R1367, R1368, R1369, R1370, R1371, R1372, R1438, R1439, R1440	07-90101-01	Chip Resistor	100R,0805,1/8W,±5%
R1135, R1136, R1137, R1138, R1139, R1140, R1141, R1142, R1162, R1163, R1164, R1165, R1166, R1167, R1449, R1450	07-90221-01	Chip Resistor	220Ω,0805,1/8W,±5%
R1091	07-92700-01	Chip Resistor	270Ω,0805,±1%
R1447, R1448	07-97150-01	Chip Resistor	715R,0805,1/8W,±1%
R1090, R1377, R1378, R1379, R1380, R1381, R1382, R1398, R1399, R1400, R1401, R1402, R1403, R1443, R1444, R1445	07-98200-01	Chip Resistor	820R,0805,1/8W,±1%
R1027, R1028, R1029, R1030, R1031, R1032, R1033, R1034, R1035, R1036, R1037, R1038, R1039, R1040	07-90102-01	Chip Resistor	1K,0805,1/8W,±5%
R1019, R1020	07-91101-01	Chip Resistor	1.1K, 1/8W, 1%, 0805
R1375, R1376	07-91301-01	Chip Resistor	1.3K,0805,1/8W,±1%
R1051, R1052, R1053, R1054, R1055, R1056	07-92001-01	Chip Resistor	2K,0805,1/8W,±1%
R1041, R1042	07-92611-01	Chip Resistor	2.61KΩ,0805,1/10W,±1%,RC0805
R1373, R1374	07-93161-01	Chip Resistor	3.16KΩ,0805,1/8W,±1%,RC0805
R1085, R1086, R1087, R1104, R1105, R1106, R1107, R1114, R1115, R1116, R1117, R1118, R1119, R1120, R1422, R1429, R1430	07-91002-01	Chip Resistor	10K,0805,1/8W,±1%
R1015, R1016	07-91102-01	Chip Resistor	11K,0805,1/8W,±1%
R1017, R1018	07-91602-01	Chip Resistor	16K,0805,1/8W,±1%

R1416, R1417, R1418, R1419, R1420, R1421, R1441, R1442	07-92202-01	Chip Resistor	22K,0805, 1/8W,±1%
R1057, R1058, R1059, R1060, R1061, R1062, R1063, R1064, R1079, R1080, R1081, R1082, R1083, R1084	07-90563-01	Chip Resistor	56K,0805, 1/8W,±5%
R1404, R1405, R1406, R1407, R1408,R1446	07-90104-01	Chip Resistor	100K,0805, 1/8W,±5%
R1357, R1358, R1359, R1360, R1361, R1362, R1363, R1364	07-90105-01	Chip Resistor	1M,0805, 1/8W,±5%
R1409, R1410, R1411, R1412	07-90510-02	Chip Resistor	51Ω,1206, 1/4W,±5%
R1000, R1001, R1003, R1004, R1006	07-90101-10	Chip Resistor NET	100R,R0603x4,±5%
R1002, R1005, R1129	07-90121-10	Chip Resistor NET	120R, 5%, R0603X4
	CRYSTALS		
X1001	04-22452-02	Crystal	24.576MHz 10ppm,CL=15pF,SMD 5*7
	BEAD		
R1007, R1010	08-04601-08	Bead	CBW201209U601T
	RELAY		
K1201	12-02202-10	SIGNAL RELAY	HFD3 5V
	CONNECTOR		
J1001, J1002, J1003, J1004, J1005	17-01004-17	4POL RCA	AV4-8.4-13
	67-151007-0B	Rear Panel Audio	SECC-N5 T=1.6mm
	80-151007-0	Rear Panel Audio	SECC-N5 T=1.6mm
	65-151007-0	Rear Panel Audio	SECC-N5 T=1.6mm
	61-023208-0	Self Taping Screw	BTB3X8
PCB-2:AUDIO 7.1 DAC BOARD			
CIRCUIT NO.	PART NO.		DESCRIPTION
	PCB INFO		
	A16-31701-21	AUDIO 7.1 DAC PCB	VM1.0 FR-4,1.6mm,TG130,158.5x139.5mm
	DIODES		
D1532	33-44148-19	Switch Diode	1N4148W-7-F
	IC		
U1528	03-00541-05	Octal Buffer	74AC541, SOIC0.3inch, Tube/Tape
U1529	03-00541-08	Octal Buffer	74HC541, SOIC0.3inch, Tube/Tape
U1529	or 03-00541-06	Octal Buffer	74HC541, SOIC0.3inch, Tube/Tape
U1537	03-00734-01	Buffer	NC7NZ34K8X
U1536	03-00716-01	Buffer	NC7WZ16P6X
U1534, U1542	03-01117-33	Regulator IC	ASM1117-3.3
U1538, U1539, U1540	03-00138-05	Line Decoder	74HC138D
U1538, U1539, U1540	or03-00138-02	Line Decoder	MM74HC138M
U1541	03-00595-01	Shift Registers	SN74HC595D/74HC595D/MM74HC595M
U1535	03-03318-00	Analog Volume Control	CS3318-CQZ
U1532	03-07805-00	Regulator IC	L7805CV
U1530	03-07809-03	Regulator IC	LM7809
U1531	03-07909-00	Regulator IC	LM7909
IC1501	A03-00817-11	Photo Coupler	EL817(B)-F
	CAPACITOR		
C1506, C1507, C1508, C1509, C1510, C1511, C1512, C1513, C1514, C1515, C1520, C1521, C1523, C1524, C1525, C1693, C1694, C1695, C1696, C1702, C1703, C1704, C1705, C1706, C1722, C1764, C1765, C1766, C1767, C1768, C1802, C1613, C1614, C1616, C1617, C1618	26-10451-00	Chip capacitor	0603, 100NF, 50V, Y5V
C1545, L1500	26-10251-11	Chip capacitor	0805, 1nF, 50V, NPO
C1784, C1801	06-10011-11	Chip Tan capacitor	10UF 10V 20%
C1761	26-10621-12	Chip capacitor	10uF,25V,±10%,1206,X5R
C1605, C1606, C1607, C1608, C1609, C1610, C1611, C1612	25-22312-09	Metallized polystyrene Film Capacitor	CBB11,22nF, 100V, ±5%
C1516, C1758, C1760, C1769, C1770, C1818	06-22021-05	ALU Electrolytic CAP	CD284, 22UF, 25V, 20%,
C1755, C1756, C1762, C1763	06-33021-02	Alu Electrolytic Capacitor	SSG,33uF,25V,±20%,F2.5
C1771, C1772, C1794, C1795, C1796, C1797, C1798, C1799, C1800	06-33121-00	ALU Electrolytic CAP	CD263, 330uF, 25V 20%
C1634, C1635, C1636, C1637, C1638, C1639, C1640, C1641	06-22011-04	ALU Electrolytic CAP	CD71, 22uF, 16V, ±20%
	RESISTOR		
R1645	07-90121-00	Chip resistor	0603, 120R, 5%
R1696, R1697	07-90471-00	Chip resistor	0603, 470R, 5%
R1502, R1503, R1510, R1687	07-90103-00	Chip resistor	0603, 10k, 5%
R1724	07-90100-01	Chip resistor	0805, 10R, 5%
R1654	07-90000-02	Chip resistor	1206, 0R, 5%
R1651	07-90330-10	Chip resistor	33R, 5%, R0603X4
R1652	07-90820-10	Chip resistor	82Ω,0603X4,±5%,YC164-JR-0782RL
R1647, R1653	07-90101-10	Chip resistor	100R, 5%, R0603X4

R1646, R1692, R1693, R1694, R1695	07-90121-10	Chip resistor	120R, 5%, R0603X4
	CONNECTOR		
U1504, U1505, U1506, U1507(上)	13-22516-06	Connector	CNT-F254-2*8-GS-850-N, 2.54, 2X8Pin
U1504, U1505, U1506, U1507(下)	13-22510-09	Connector	CNT-F254-2*5-GS-850-N, 2.54,2X5Pin
J1011	13-22024-00		
	METAL PARTS		
	85-048001-0	PCB Spacer	LCI-11
HS1500	61-023206-0	Self Tapping Screw	BTB3x6
HS1500	70-004001-0	Heat sink	
PCB-3:MODULE BOARD			
CIRCUIT NO.	PART NO.		DESCRIPTION
	PCB INFO		
	A16-11510-21	MODULE PCB	VM1.0 FR-4,1.6mm,1oz,TG130, 26.7mmX66.5mm
	IC		
U1521	03-01796-01	Digital to analog convertor	PCM1796DB
U1501, U1502	03-01652-00	Opamp	OPA1652AID
U1501, U1502	or 03-00275-01	Opamp	OP275GSZ
U1509	03-49725-01	Dual OpAmp	LME49725MA
U1503	03-01117-01	Regulator	AMS1117-5.0
U1508	03-00082-01	Dual OpAmp	TL082BCD
U1508	or N03-02131-01	Dual OpAmp	OPA2131UA
	CAPACITOR		
C1519, C1548	26-22351-00	Chip capacitor	0603, 22NF, 50V, X7R
C1517, C1546, C1707, C1708, C1712, C1713, C1720, C1731, C1732, C1733	26-10451-00	Chip capacitor	0603, 100NF, 50V, Y5V
C1563, C1564	26-10521-10	Chip capacitor	1uF,25V,±10%,0603,X5R
C1541	26-10251-11	Chip capacitor	0805, 1nF, 50V, NPO
C1582, C1583, C1584, C1585	26-12251-11	Chip capacitor	0805, 1.2NF, 50V, NPO 5%
C1558, C1559, C1561, C1562	26-22251-21	Chip capacitor	0805, 2.2NF, 50V, NPO 5%
C1502, C1503, C1574, C1575, C1651, C1652	26-68221-01	Chip capacitor	6.8nF,25V,±5%,0805,NPO
C1586	26-22521-01	Chip capacitor	2.2uFK, 25V X5R, 0805
C1501	26-10611-11	Chip capacitor	10uFK, 10V, X5R 0805
C1500	26-22660-11	Chip capacitor	22U/6V3 X5R 0805
C1554, C1806	27-10160-00	Chip Tan capacitor	100uF,6.3V,20%,3528
C1504	06-33011-04	Chip Alu capacitor	33U/16V E5*5.4
C1807, C1808	06-22021-06	Chip Alu capacitor	VES-25V220ME55R, 22uF, 25V, ±20%, 105°C, 5*5.4
C1809, C1810	27-10160-00	Chip Tan capacitor	100UF 6.3V 20%
	RESISTOR		
R1588	07-90100-00	Chip resistor	0603, 10R, 5%
R1727	07-90101-00	Chip resistor	0603, 100R, 5%
R1500, R1501	07-90103-00	Chip resistor	0603, 10k, 5%
R1524, R1525, R1586, R1587	07-94701-00	Chip resistor	0603, 4.7k, 1%
R1526, R1527	07-91004-00	Chip resistor	0603, 1M, 1%
R1584, R1585	07-90101-01	Chip resistor	0805, 100R, 5%
R1520, R1521, R1522, R1523, R1552, R1553, R1554, R1555	07-93300-01	Chip resistor	0805,330R, 1%
R1536, R1537, R1538, R1539	07-94530-01	Chip resistor	0805, 453R, 1%
R1504, R1505, R1507, R1508	07-98200-01	Chip Resistor	0805,820Ω, ±1%
	CONNECTOR		
CON1503	13-12516-02	Connector	CNT-M254-2*8-GS-6/3-N, 2.54, 2X8Pin
CON1504	13-12510-11	Connector	CNT-M254-2*5-GS-6/3-N, 2.54, 2X5Pin
PCB-4:AUDIO INTERFACE BOARD			
CIRCUIT NO.	PART NO.		DESCRIPTION
	PCB INFO		
	A16-31702-22	AUDIO Interface	VM1.1 FR-4,1.6mm,1oz,TG130
	DIODES		
D1500, D1501, D1502, D1503, D1504, D1505, D1506, D1507,D1528,D1529, D1530,D1531	33-44148-17	Switch Diode SMD	1N4148W-NR
D1508, D1509, D1512, D1513, D1514, D1515, D1516, D1517, D1520, D1521	33-40352-01	Diodes	1SS352
	TRANSISTORS		
Q1500, Q1501, Q1502, Q1503, Q1504, Q1505, Q1506, Q1507,Q1509, Q1510, Q1511, Q1512	31-01815-03	Transistor	C1815
Q1508	31-01015-03	Transistor	A1015

	IC		
U1513, U1514, U1515, U1516, U1517, U1518, U1519, U1520, U1500, U1501, U1502, U1503	03-49725-01	Dual OpAmp	LME49725MA
	CAPACITOR		
C1687, C1688, C1689, C1690, C1691, C1692, C1700, C1701, C1724, C1725, C1726, C1727, C1735, C1736, C1737, C1738, C1586, C1587, C1588, C1589, C1590, C1591, C1592, C1593	26-10451-00	Chip capacitor	0603, 100NF, 50V, Y5V
C1667, C1668, C1669, C1670, C1671, C1672, C1673, C1674, C1594, C1595, C1596, C1597	26-10351-00	Ceramic Chip Capacitor	10nK,50V,0603,X7R
C1675, C1676, C1677, C1678, C1679, C1680, C1681, C1682, C1774, C1775, C1776, C1777, C1778, C1779, C1780, C1781, C1598, C1599, C1600, C1601	26-10151-00	Ceramic Chip Capacitor	100pJ,50V ,0603,NPO
C1517, C1519, C1535, C1537, C1548, C1549, C1561, C1563, C1510, C1511, C1512, C1514, C1525, C1545, C1580, C1582	26-22051-01	Ceramic Chip Capacitor	100pJ,50V ,0603,NPO
C1522, C1526, C1527, C1528, C1529, C1530, C1531, C1532, C1550, C1551, C1552, C1553, C1554, C1555, C1556, C1557, C1747, C1748, C1749, C1750, C1751, C1752, C1753, C1754, C1503, C1534, C1544, C1559, C1560, C1610, C1611, C1612, C1613, C1614, C1615, C1616, C1617, C1618, C1627, C1628, C1629, C1630, C1631, C1632, C1633, C1634, C1635, C1636, C1637, C1638, C1639, C1640, C1641, C1642, C1651, C1652	26-22151-01	Chip capacitor	0805, 220PF, 50V, NPO
C1503, C1533, C1543, C1685, C1686	26-22351-01	Chip capacitor	0805, 22NF, 50V, X7R
C1504, C1505, C1536, C1538, C1546, C1547, C1558, C1562, C1619, C1620, C1621, C1622, C1623, C1624, C1625, C1626, C1508, C1509, C1513, C1515, C1523, C1524, C1581, C1583	25-22312-09	Metallized polystyrene Film Capacitor	CBB11,22nF, 100V, ±5%
C1566, C1567, C1568, C1569, C1570, C1571, C1572, C1573, C1574, C1575, C1576, C1577, C1578, C1579, C1757, C1759, C1602, C1603, C1604, C1605, C1606, C1607, C1608, C1609	06-22021-05	ALU Electrolytic CAP	CD284, 22UF, 25V, 20%,
C1500, C1501, C1539, C1540, C1541, C1542, C1564, C1565, C1643, C1644, C1645, C1646, C1647, C1648, C1649, C1650, C1506, C1507, C1516, C1518, C1520, C1521, C1584, C1585	06-22011-04	ALU Electrolytic CAP	CD71, 22uF, 16V, ±20%
	RESISTOR		
R1649	07-90121-00	Chip resistor	0603, 120R, 5%
R1655, R1656, R1657, R1658, R1659, R1660, R1661, R1662	07-90102-00	Chip resistor	0603, 1K, 5%
R1688, R1690	07-90222-00	Chip resistor	0603, 2K2, 5%
R1608, R1609, R1610, R1611, R1612, R1613, R1614, R1615, R1616, R1617, R1618, R1619, R1620, R1621, R1622, R1623, R1604, R1605, R1606, R1607, R1624, R1625, R1628, R1629	07-90472-00	Chip resistor	0603, 4K7, 5%
R1679, R1680, R1681, R1682, R1683, R1684, R1685, R1686	07-90103-00	Chip resistor	0603, 10k, 5%
R1500, R1501, R1504, R1521, R1523, R1524, R1525, R1526, R1527, R1543, R1544, R1626, R1627, R1700, R1701, R1702, R1703, R1704, R1705, R1706, R1707, R1708, R1709, R1710, R1711, R1712, R1713, R1714, R1715, R1502, R1506, R1572, R1574, R1584, R1586, R1600, R1602	07-90101-01	Chip resistor	0805, 100R, 5%
R1545, R1546, R1547, R1548, R1549, R1550, R1551, R1552, R1553, R1554, R1555, R1556, R1557, R1558, R1559, R1560, R1503, R1509, R1573, R1575, R1585, R1587, R1601, R1603	07-91001-01	Chip resistor	0805, 1k, 1%
R1677	07-91600-01	Chip resistor	0805, 160R, 1%

R1508, R1512, R1518, R1520, R1530, R1532, R1538, R1540	07-98250-01	Chip resistor	825Ω,0805,1/8W,±1%,RC0805FR-07825RL
R1507, R1511,R1517, R1519, R1529, R1531, R1537, R1539, R1663, R1664, R1665, R1666, R1667, R1668, R1669, R1670, R1671, R1672, R1673, R1674, R1675, R1676, R1678,R1510, R1561, R1562, R1563, R1568, R1569, R1570, R1571, R1588, R1589, R1590, R1591, R1596, R1597, R1598, R1599	07-91651-01	Chip resistor	0805, 1.65K, 1%
R1513, R1514, R1515, R1516, R1533, R1534, R1535, R1536, R1576, R1577, R1578, R1579, R1580, R1581, R1582, R1583,R1564, R1565, R1566, R1567, R1592, R1593, R1594, R1595	07-90223-01	Chip resistor	0805, 22K, 5%
	RELAY		
K1500, K1501, K1502, K1503, K1504, K1505, K1506, K1507,K1508, K1509, K1510, K1511	12-02202-15	SIGNAL RELAY	HFD31/5 5VDC
	CONNECTOR		
J1504	17-01001-07	1POL RCA	RCA1-BK 1 heads,Black,AV-8.4-14PB1
J1502	17-01004-17	4POL RCA	AV4-8.4-13
J1503	17-01004-18	4POL RCA	AV4-8.4-13,
J1500, J1501, J1505, J1506, J1507, J1508, J1509, J1510	J17-09103-13		
J1511	13-22024-00		
	14-31724-00	Connector Wire	24Pin,L=60mm,CNT-C200-24-60
PCB-5:IO BOARD			
CIRCUIT NO.	PART NO.		DESCRIPTION
	PCB INFO		
	MA16-31703-22	IO PCB	VM1.1 FR-4,1.6mm,2 LAYERS,1oz,TG130,
	TRANSISTORS		
Q6001	31-00143-01	Digital transistor	DTC143
	IC		
U6001	03-00132-02	Quad 2-Input NAND Gate	74HC132
U6002	03-00100-02	SINGLE-NANDGATE	SN74AHC1G00DBVR
	RESISTOR		
R6005	07-90000-00	Chip Resistor	0R ,0603, 1/10W, 5%
R6001	07-90104-00	Chip Resistor	100K,0603, 1/10W
R6002, R6003	07-90330-00	Chip Resistor	33R,0603,1/10W,±5%
R6006	07-90100-01	Chip Resistor	10R,0805,1/8W,±5%
	CAPACITOR		
C6001	26-10451-00	Ceramic Chip Capacitor	100n
C6002	06-10011-09		10u/16V, 20%, 4*5.4
	CONNECTOR		
CON6002, CON6003, CON6005, CON6001, CON6007, CON6008	13-21246-00	AMR-46pins	EH02311-DCB-DF
CON6004, CON6006	13-22520-11		2.54*2*10 DIP
CON6009, CON6015	13-22502-00		CON2.54/2P
CON6010	13-22508-00		CON2.54/8P
CON6014, CON6013	13-23906-00		CON3.96/6P
CON6012	13-23904-00		CON3.96/4P
PCB-6:HDMI BOARD			
CIRCUIT NO.	PART NO.		DESCRIPTION
	PCB INFO		
	A16-11523-21	HDMI PCB	REV.2, 8 LAYERS,, 228.5x125.5mm
	DIODES		
D105, D106, D107, D108, D109, D110	33-50603-01	GREEN LED	SML-310MTT86
D111, D112	33-44148-17	Switch Diode SMD	1N4148W-NR
D114, D115	33-20003-00	Diode	ES3D,200V,3A
D113	33-20054-03	Schottky Diode	BAT54
D113	or 33-20054-02	Schottky Diode	BAT54,215
	TRANSISTORS		
Q100	31-94052-01	P-Channel MOSFET	MIC94052YC6TR
	IC		
U101	03-04616-02	DDR SDRAM	MT46V16M16P-5B:K
U101	orN03-56163-02	DDR SDRAM	K4H561638N-LCCC
U102	03-01262-02	DDR SDRAM	H5DU1262GTR-E3C

U102	orN03-46816-01	DOUBLE DATA RATE DDR SDRAM	MT46V8M16TGP
U124, U129	03-73701-01	1A Low-Dropout Regulator	TPS73701DCQR
U119, U120, U121, U122, U123	03-62110-01	DC/DC Converter	TPS62110RSAR
U117, U118	03-00524-03	ESD Production IC	RClamp0524PA
U117, U118	or 03-04010-01	ESD Production IC	TPD4S010DQAR
U115	03-02996-01	DDR Termination Regulator	LP2996MRX
U109	03-08895-01	Ethernet Switch	KSZ8895MQ
U100	03-15238-01	CYCLONE IV FPGA	EP4CE15F23C8N
U108	03-42460-01	Ethernet Controller	ENC424J600-I/PT
U110, U111	03-44173-01	Video Reconstruction Filter	ADA4417-3ARMZ-R7
U104	03-07340-01	Video DACs	ADV7340BSTZ
U105, U106	03-07511-01	HDMI Transmitter	ADV7511KSTZ
U103	03-07844-01	HDMI Receiver	ADV7844KBCZ-5
U112	03-00244-01	Octal Buffer	74LCX244WM/74LCX244WMX/ MC74LCX244DWR2G/
U116, U125, U126, U127, U128, U130, U131	03-79901-01	LDO	TPS79901DDCR
D103, D104	03-02030-01	ESD Production	CM2030-A0TR
D100, D101, D102	03-02031-01	ESD Production	CM2031-A0TR
U113	03-09517-02	I2C Repeater	PCA9517DR
U114	03-02564-03	Serial FLASH	M25P64-VMF6TP
CAPACITOR			
C1042, C1044, C1046, C1049, C1051, C1053, C1055, C1057, C1059, C1062, C1064, C1066, C1068, C1070, C1072, C1074, C1076, C1078, C1080, C1082, C1084, C1136, C1138, C1140, C1142, C1145, C1147, C1149, C1151, C1153, C1156, C1158, C1160, C1162, C1164, C1167, C1169, C1171, C1173, C1175, C1178, C1101, C1102, C1103, C1104, C1105, C1106, C1111, C1113, C1114, C1115, C1116, C1117, C1122, C1123, C1124, C1125, C1128, C1129, C1130, C1131, C1087, C1088, C1089, C1090, C1091, C1092, C1093, C1094, C1099, C1100	26-10351-08	Ceramic Chip Capacitor	10nF,50V,0402,X7R,±10%
C1041, C1043, C1045, C1048, C1050, C1052, C1054, C1056, C1058, C1061, C1063, C1065, C1067, C1069, C1071, C1073, C1075, C1077, C1079, C1081, C1083, C1086, C1144, C1146, C1148, C1150, C1152, C1155, C1157, C1159, C1161, C1163, C1166, C1168, C1170, C1172, C1174, C1177, C1135, C1137, C1139, C1141, C1266, C1118, C1119, C1120, C1126, C1127, C1132, C1133, C1095, C1096, C1097, C1107, C1108, C1109, C1112	26-10411-08	Ceramic Chip Capacitor	100nF,16V,X7R,±10%
C166, C171, C176, C181, C186	26-10051-00	Ceramic Chip Capacitor	10pJ,50V,0603,NPO
C138, C139, C144, C145	26-33051-00	Ceramic Chip Capacitor	33pJ,50V,0603,NPO
C121, C122	26-47051-00	Ceramic Chip Capacitor	47PJ,50V,0603,NPO
C117, C189	26-10251-10	Ceramic Chip Capacitor	1nJ,50V,0603,NPO
C100, C1032	26-22251-10	Ceramic Chip Capacitor	2n2J,50V,0603,NPO
C153, C162, C193, C1010, C1013, C1017, C1020, C1026, C1029, C1196, C1198, C1202, C1204, C1206, C1209, C1211, C1213, C1216, C1218	26-10351-00	Ceramic Chip Capacitor	10nK,50V,0603,X7R,±10%
C155, C1016	26-12351-10	Ceramic Chip Capacitor	12nK,0603,50V,X7R
C155, C1016	or26-12351-00	Ceramic Chip Capacitor	12nF,0603,50V,X5R
C111, C112, C113, C114, C115, C116, C118, C119, C131, C132, C142, C143, C146, C147, C152, C156, C158, C160, C194, C195, C196, C197, C198, C199, C1000, C1001, C1002, C1003, C1004, C1005, C1007, C1023, C1031, C1179, C1180, C1181, C1183, C1184, C1185, C1187, C1188, C1189, C1190, C1192, C1193, C1194, C1197, C1199, C1203, C1205, C1207, C1208, C1210, C1212, C1215, C1217, C1219, C1220, C1221, C1222, C1223, C1224, C1225, C1226, C1228, C1229, C1230, C1231, C1232, C1233, C1234, C1235, C1237, C1238, C1239, C1240, C1241, C1242, C1243, C1244, C1245, C1246, C1247, C1248, C1249, C1250, C1251, C1253, C1254, C1255, C1256, C1257, C1258, C1259, C1265, C1267, C103, C104, C105, C106, C107, C108, C109, C110, C1261, C1262, C1263, C1264, C190	26-10451-10	Ceramic Capacitor SMD	100nK,50V,0603,X7R,±10%
C154, C161	26-15421-00	Ceramic Capacitor SMD	150nK,25V,0603,X7R,C1608X7R1E154KT000N

C124, C125, C133, C136, C157, C165, C170, C175, C180, C185	26-10511-20	Ceramic Chip Capacitor	1uK,16V,0603,X7R
C120, C1009, C1011, C1015, C1018, C1019, C1021, C1025, C1027, C1028, C1030	26-10611-21	Ceramic Chip Capacitor	10uK,16V,0805,X5R
C1214, C1200, C1201, C1252, C1268, C140	26-10611-22	Ceramic Chip Capacitor	10uK,16V,1206,X7R
C150, C151, C167, C172, C177, C182, C187	26-22611-22	Ceramic Capacitor SMD	22uF,16V,X5R,1206,±20%
C1006, C1012, C1022	06-10951-01	Chip Alu Electrolytic Capacitor	1uF, 50V, 20%, 4*5.4
C1014	06-22951-08	Chip Alu Electrolytic Capacitor	2.2uF, 50V, 20%, 4*5.4
C1085, C1134, C1260	06-10011-11	Chip Tan Electrolytic Capacitor	10uF,10V,±20%
C1098, C1110, C1121, C1143, C1154, C1165, C1176, C1227, C1236, C1182, C1191, C1195, C1186,C159,C163	06-22060-02	Chip Tan Electrolytic Capacitor	22uF, 6.3V, ±20%, TPSA226M006R0500
C1047, C1060	06-47060-10	Chip Tan Electrolytic Capacitor	CA45B, 47uF, 6.3V
C149, C179, C183, C184, C188, C191	06-10021-06	Chip Alu Electrolytic Capacitor	VSS or CS or VE2 Series,10uF,25V,±20%,85℃
C192, C168, C173, C1008, C1024	06-47011-11	Electrolytic Capacitor SMD	47uF, 16V, ±20%,EEE1CA470WR
C169, C164, C178, C174	06-47011-18	Electrolytic Capacitor SMD	47uF,10V,±20%,VZH470M1A0506-TR0
	RESISTOR		
R1366	07-90000-08	Chip Resistor	0R 0402
R1277, R1375	07-92209-08	Chip Resistor	22Ω,0402,1/16W,±1%
R158, R159, R161, R170, R171, R172, R173, R174, R175, R176, R177	07-91000-08	Chip Resistor	100Ω,0402,1/16W,±1%
R114, R115, R116, R117, R118, R119, R120, R121, R122, R123, R124, R125, R126, R127, R128, R129, R130, R131, R162, R163, R1258, R1376, R1159, R1163, R1166, R1168, R1185, R1316, R1337, R1338, R1339, R1356, R1367, R100, R198, R1259, R1263, R1264, R1381, R1383	07-90000-00	Chip Resistor	0Ω, 0603, ±5%
R1215	07-91008-00	Chip resistor	1Ω,0603,1/10W,±1%
R168	07-94998-00	Chip Resistor	4.99Ω,0603,1/10W,±1%
R1123, R1124, R1127, R1128, R1129, R1130, R1131, R1132, R1133, R1134, R1137, R1138, R1139, R1140, R1143, R1144, R1147, R1148	07-91009-00	Chip resistor	10Ω,0603,1/10W,±1%
R143, R144, R150, R151, R152, R153, R154, R157, R178, R1008, R1112, R1113, R1114, R1115, R1116, R1117, R1118, R1119, R1173, R1204, R1205, R1211, R1213, R1222, R1223, R1241, R1242, R1244, R1245, R1247, R1254, R1255, R1257, R1265, R1266, R1269, R1270, R1278, R1279, R1319, R1348, R1389	07-92209-00	Chip resistor	22Ω,0603,1/10W,±1%
R148, R149, R1174, R1309, R1310, R1311, R1312	07-92409-00	Chip Resistor	24Ω,0603,1/10W,±1%,RC0603FR-0724RL
R1260, R1371, R1372, R1373, R1374	07-94709-00	Chip resistor	47Ω,0603,1/10W,±1%
R164, R165, R1179, R1180, R1182, R1183, R1377, R1378, R1379, R1380, R1385, R1386, R1387, R1388	07-94999-00	Chip Resistor	49.9Ω,0603,1/10W,±1%
R108, R109, R110, R111, R112, R113	07-95109-00	Chip Resistor	51Ω,0603,1/10W,±1%
R1151, R1152, R1153, R1186, R1187, R1188	07-97509-00	Chip Resistor	75Ω,0603,1/10W,±1%
R1229	07-91000-00	Chip Resistor	100Ω,0603,1/10W,±1%
R1003, R1004	07-91690-00	Chip Resistor	169Ω,0603,1/10W,±1%
R1176, R1177	07-91800-00	Chip Resistor	180Ω,0603,1/10W,±1%,RC0603FR-07180RL
R1154, R1155, R1156, R1169, R1170, R1171, R1172, R1189, R1190, R1191	07-93000-00	Chip Resistor	300Ω,0603,1/10W,±1%
R155	07-94990-00	Chip Resistor	499Ω,0603,1/10W,±1%
R160, R182	07-98870-00	Chip Resistor	887Ω,0603,1/10W,±1%
R1009, R1110, R1111, R1328, R1233, R1234	07-91001-00	Chip Resistor	1KΩ,0603,1/10W,±1%
R180, R1000	07-91241-00	Chip Resistor	1.24KΩ,0603,1/10W,±1%
R184, R185, R190, R191	07-92001-00	Chip Resistor	2KΩ,0603,1/10W,±1%
R107, R1002	07-94121-00	Chip Resistor	4.12KΩ,0603,1/10W,±1%
R105, R106, R1121, R1125, R1126, R1122, R1135, R1136, R1141, R1142, R1149, R1150, R1207, R1209, R1307	07-94701-00	Chip Resistor	4.7KΩ,0603,1/10W,±1%
R181, R1001	07-94991-00	Chip Resistor	4.99KΩ,0603,1/10W,±1%
R140, R141, R156, R169, R179, R183, R186, R187, R188, R189, R192, R193, R194, R195, R1157, R1161, R1162, R1208, R1214, R1318, R1322, R1323, R1324, R1325, R1330, R1331, R1332, R1333, R1340, R1341, R1342, R1343, R1391, R1392	07-91002-00	Chip Resistor	10KΩ,0603,1/10W,±1%
R1178, R1181	07-91242-00	Chip Resistor	12.4KΩ,0603,1/10W,±1%
R1347	07-92702-00	Chip Resistor	27KΩ,0603,1/10W,±1%
R1349	07-92872-00	Chip Resistor	28.7KΩ,0603,1/10W,±1%,RC0603FR-0728K7L
R1361	07-92942-00	Chip Resistor	29.4KΩ,0603,1/10W,±1%
R1299	07-93162-00	Chip Resistor	31.6KΩ,0603,1/10W,±1%,RC0603FR-0731K6L

R132, R133, R145, R1327, R1329, R1334, R1336, R1345, R1346, R1390	07-94702-00	Chip Resistor	47KΩ,0603,1/10W,±1%
R1360	07-95232-00	Chip Resistor	52.3KΩ,0603, 1/10W, ±1%, RC0603FR-0752K3L
R1351	07-95622-00	Chip Resistor	56.2KΩ,0603,1/10W,±1%,RC0603FR-0756K2L
R1284	07-91963-00	Chip Resistor	196KΩ,0603,1/10W,±1%
R1289	07-92263-00	Chip Resistor	226KΩ,0603,1/10W,±1%,RC0603FR-07226KL
R1304	07-92373-00	Chip Resistor	237KΩ,0603,1/10W,±1%,RC0603FR-07237KL
R1294	07-92743-00	Chip Resistor	274KΩ,0603, 1/10W, ±1%
R1293	07-93323-00	Chip Resistor	332KΩ,0603,1/10W,±1%,RC0603FR-07332KL
R1321, R1352, R1354, R1362, R1364	07-93833-00	Chip Resistor	383KΩ,0603,1/10W,±1%,RC0603FR-07383KL
R1305	07-94123-00	Chip Resistor	412KΩ,0603,1/10W,±1%,RC0603FR-07412KL
R1288	07-94323-00	Chip Resistor	432KΩ,0603,1/10W,±1%,RC0603FR-07432KL
R1359	07-94753-00	Chip Resistor	475KΩ,0603,1/10W,±1%,RC0603FR-07475KL
R1358	07-95233-00	Chip Resistor	523KΩ,0603, 1/10W, ±1%,RC0603FR-07523KL
R1300	07-96043-00	Chip Resistor	604KΩ,0603,1/10W,±1%
R1283	07-96653-00	Chip Resistor	665KΩ,0603,1/10W,±1%,RC0603FR-07665KL
R1320	07-96813-00	Chip Resistor	681KΩ,0603,1/10W,±1%,RC0603FR-07681KL
R1353, R1355, R1363, R1365	07-97323-00	Chip Resistor	732KΩ,0603,1/10W,±1%,RC0603FR-07732KL
R1280, R1282, R1285, R1287, R1290, R1292, R1296, R1298, R1301	07-91004-00	Chip Resistor	1MΩ,0603,1/10W,±1%
R139, R1240, R1253, R1306, R1314	07-90220-28	Resistor NET	22Ω,R0402X4,0.063W,YC124-JR-0722R
R1219	07-90470-28	Resistor NET	47Ω,R0402X4,0.063W,YC124-JR-0747R
R101, R102, R103, R104, R135, R136, R137, R138, R142, R196, R1224, R1225, R1227, R1228, R1236, R1237, R1238, R1239, R1249, R1250, R1251, R1252, R1276, R1313, R1315, R1368	07-90220-38	Resistor NET	22Ω,R0602X8,0.063W,YC248-JR-0722R
R1217, R1218, R1220, R1221	07-90470-18	Resistor NET	47Ω,R0602X8,1/16W,±5%, YC248-JR-0747RL
	INDUCTOR		
L109, L110, L111, L112, L113	08-04629-00	Power Inductor	6.2uH,MSS7341-622NL
L105, L106	08-04100-02	Inductor SMD	10uH, ±10%, 0805
L108	08-04101-02	Ferrite SMD	100R@100MHz,CBG321609U101T
L103,L104	08-04208-00	Inductor SMD	LQW18ANR20G00D,200nH,±2%
	CRYSTALS		
Y101, Y102	04-12502-08	Crystal SMD	CB-F-25.000M-18-3050-1060
Y101, Y102	or04-12502-07	Crystal SMD	CS10-25.000MABJ-UT
Y100	04-12862-04	Crystal SMD	6035SMD-2PAD 28.63636MHZ/18PF
Y100	or04-12862-00	Crystal SMD	28.63636MHZ,CS10-28.63636MABJ-uT
Y103	04-22702-04	Oscillator	OF-2.5-6-27.000M-20-1070-1
Y103	or04-22702-03	Clock Oscillator	27.0000Mhz, 2.5V, 20PPM, O27.0-VX3DP
	CONNECTOR		
J2, J4, J5, J30, J4504	17-08119-02	HDMI Socket	1747981-1
J101	13-08040-00	HIGH SPEED SOCKET	20x2Pins, QTE-020-07-F-D-A
	07-20103-50	Metal Film Resistor	10KΩ,1/6W,±5%
	06-10951-02	Alu Electrolytic Capacitor	CD110,1uF,50V ±20%,F2.5
H105, H106, H107, H108, H109, H110, H111	13-12502-15	CONNECTOR	2Pin,2.54mm
H102, H104	13-12503-13	CONNECTOR	3Pin,2.54mm
H101, H112	13-22504-12	CONNECTOR	4Pin,2.54mm
H103	13-22505-07	CONNECTOR	2.54mm, 5Pin, CNT-W254-1*5-TS-1140
H100	13-22510-12	Connector	2.54mm,2*5Pin
	67-151005-3	HDMI Bracket	SECC-N5 T=1.0mm
PCB-7:HDMI EXPANDER BOARD			
CIRCUIT NO.	PART NO.		DESCRIPTION
	PCB INFO		
	A16-11522-21	HDMI EXPANDER PCB	VM1.0, FR-4,1.6mm,6 LAYERS,1OZ,TG130, 120.4X122mm
	IC		
U200	03-03014-01	HDMI Switch	ADV3014KSTZ
D200, D201, D202, D203	03-02031-01	ESD Production	CM2031-A0TR
U208, U209	03-79901-01	LDO	TPS79901DDCR
U205, U206, U207	03-73701-01	1A Low-Dropout Regulator	TPS73701DCQR

U203, U204	03-62110-01	DC/DC Converter	TPS62110RSAR
U202	03-00524-03	ESD Production IC	RClamp0524PA
U202	or 03-04010-01	ESD Production IC	TPD4S010DQAR
	CAPACITOR		
C200, C201	26-47051-08	Ceramic Capacitor SMD	47pF,±5% ,COG 50V,C1005C0G1H470JT
C209, C211, C213, C215, C217, C219, C221, C223, C225, C227, C229, C231, C233, C235, C237, C239, C241, C243, C245, C247	26-10351-08	Ceramic Chip Capacitor	10nF,50V,0402,X7R,±10%
C208, C210, C212, C214, C216, C218, C220, C222, C224, C226, C228, C230, C232, C234, C236, C238, C240, C242, C244, C246, C248, C249, C250, C251, C252, C253, C254, C255, C256, C286, C287	26-10411-08	Ceramic Chip Capacitor	100nF,16V,X7R,±10%
C259, C264	26-10051-00	Ceramic Chip Capacitor	10pJ,50V,0603,NPO
C277, C280	26-10351-00	Ceramic Chip Capacitor	10nK,50V,0603,X7R,±10%
C202, C203, C204, C205, C206, C207, C268, C271, C274, C288, C289	26-10451-10	Ceramic Capacitor SMD	100nK,50V,0603,X7R,±10%
C258, C263	26-10511-20	Ceramic Chip Capacitor	1uK,16V,0603,X7R
C276, C278, C279, C281	26-10611-21	Ceramic Chip Capacitor	10uK,16V,0805,X5R
C260, C265	26-22611-22	Ceramic Capacitor SMD	22uF,16V,X5R,1206,±20%
C267, C270, C273,	06-10951-01	Chip Alu Electrolytic Capacitor	1uF, 50V, 20%, 4*5.4
C269, C272, C275	06-47011-11	Electrolytic Capacitor SMD	47uF, 16V, ±20%,EEE1CA470WR
C257, C261, C262, C266	06-47011-18	Electrolytic Capacitor SMD	47uF,10V,±20%,VZH470M1A0506-TR0
	RESISTOR		
R228	07-90000-08	Chip Resistor	0R 0402
R240, R241, R242	07-92209-08	Chip Resistor	22Ω,0402,1/16W,±1%
R201	07-94990-08	Chip Resistor	499Ω,0402,1/16W,±1%
R200	07-98870-08	Chip Resistor	887Ω,0402,1/16W,±1%
R229, R234, R235, R245, R258	07-90103-08	Chip Resistor	10KΩ,0402,1/16W,±5%
R236, R239	07-90473-08	Chip Resistor	47KΩ,0402,1/16W,±5%
R218, R219, R220, R289	07-90000-00	Chip Resistor	0Ω, 0603, ±5%
R230, R231	07-91009-00	Chip resistor	10Ω,0603,1/10W,±1%
R246, R247	07-93000-00	Chip Resistor	300Ω,0603,1/10W,±1%,RC0603FR-07300RL
R202, R203, R204, R205, R210, R211, R212, R213, R221, R222, R223, R224, R271, R272, R273, R274, R275, R276, R277, R278, R279, R284, R285, R286, R287	07-91002-00	Chip Resistor	10KΩ,0603,1/10W,±1%
R250, R252	07-92872-00	Chip Resistor	28.7KΩ,0603,1/10W,±1%,RC0603FR-0728K7L
R249	07-92942-00	Chip Resistor	29.4KΩ,0603,1/10W,±1%
R206, R207, R209, R214, R215, R216, R225, R226, R227, R282, R283, R288	07-94702-00	Chip Resistor	47KΩ,0603,1/10W,±1%
R248	07-95232-00	Chip Resistor	52.3KΩ,0603, 1/10W, ±1%,RC0603FR-0752K3L
R251, R253	07-95622-00	Chip Resistor	56.2KΩ,0603,1/10W,±1%,RC0603FR-0756K2L
R268	07-91963-00	Chip Resistor	196KΩ,0603,1/10W,±1%
R263	07-92263-00	Chip Resistor	226KΩ,0603,1/10W,±1%,RC0603FR-07226KL
R254, R256	07-93833-00	Chip Resistor	383KΩ,0603,1/10W,±1%,RC0603FR-07383KL
R262	07-94323-00	Chip Resistor	432KΩ,0603,1/10W,±1%,RC0603FR-07432KL
R267	07-96653-00	Chip Resistor	665KΩ,0603,1/10W,±1%,RC0603FR-07665KL
R255, R257	07-97323-00	Chip Resistor	732KΩ,0603,1/10W,±1%,RC0603FR-07732KL
R259, R261, R264, R266	07-91004-00	Chip Resistor	1MΩ,0603,1/10W,±1%
	INDUCTOR		
L200, L201	08-04629-00	Power Inductor	6.2uH,MSS7341-622NL
	CRYSTALS		
Y200	04-12862-04	Crystal SMD	6035SMD-2PAD 28.63636MHZ/18PF
Y200	or04-12862-00	Crystal SMD	28.63636MHz
	CONNECTOR		
J201, J202, J203	17-08119-05	HDMI SOCKET	SD-47408-001
J200	13-08040-01	HIGH SPEED SOCKET	20x2Pins, QSE-020-01-F-D-A
H200, H201, H202, H203, H204, H205	13-12502-15	CONNECTOR	2Pin,2.54mm
E200	17-08001-38	RJ45 Connector	J00-0065NL
	67-151022-1	HDMI Bracket	SECC-N5 T=1.0mm
	MECHANICAL PARTS		
	67-151021-0A	Rear Panel HDMI	SECC-N5 T=1.6mm
	80-151021-0	Rear Panel HDMI	SECC-N5 T=1.6mm
	65-151021-0	Rear Panel HDMI	SECC-N5 T=1.6mm
	78-151011-0	PCB Insulate Sheet	PC T=0.4mm
	85-127002-0	RIVET-PLAST	RIVET PLASTIC SNAP ITW #254

	85-151011-0	SPACER SUPPORT	PDC-26D
HDMI PCB(6)	61-062506-6	Machine Screws	MF2.6X6
	69-151011-0	Copper Spacer	H62, H=25mm
	61-023506-1	Machine Screw	MB3X6-Ni
	94-151015-0	Serial No. Label	50x13mm
	86-000078-0	Copperplate Label	50x13mm
PCB-8:VID BOARD			
CIRCUIT NO.	PART NO.		DESCRIPTION
	PCB INFO		
	A16-31704-21	VID PCB	VM1.0,FR-4,1.6mm,TG130,207*164.5mm
	TRANSISTORS		
D4001, D4002, D4003, D4004	33-40352-01	Switch Diode	1SS352
Q4001, Q4002, Q4003, Q4006,Q4010, Q4011	33-40099-01	Switch Diode	BAV99
	IC		
U4001	03-06501-01	video switch	FMS6501MSA28X
	CAPACITOR		
C4001, C4002, C4003, C4004, C4005, C4006, C4007, C4008, C4009, C4010, C4011, C4012, C4013, C4014	26-10451-00	Chip capacitor	0603, 100nZ, 50V, Y5V
C4041, C4045	26-22351-00	Chip capacitor	0603, 22NF, 50V, X7R
C4033, C4034, C4037	06-22121-05	SMD Alu Electrolytic Capacitor	220UF, 25V, 20%, 8*10.5
C4042, C4043, C4044	06-47111-06	SMD Alu Electrolytic Capacitor	470UF, 10V, 20%, 8*10.5
C4029, C4030	06-10011-09	SMD Alu Electrolytic Capacitor	10UF, 16V, 20%, 4*5.4
	RESISTOR		
R4033, R4037	07-90101-00	Chip resistor	0603, 100R, 5%
R4001, R4002, R4003, R4004, R4005, R4006, R4007, R4008, R4009, R4010, R4011, R4012, R4013, R4014, R4019, R4024, R4025, R4026	07-97509-00	Chip resistor	0603, 75R, 1%
	CONNECTOR		
CON4003	13-22003-00	SOCKET	PH 2.0A-3A
J4001, J4002 J4003-4004	17-01001-29	RCA	AV-8.4-8
J4006	17-01006-01	RCA Jack	RCA6-GR-BL-R 6 heads,Green-Blue-Red,AV6-8.4-13
J4007	17-01005-00	RCA Jack	AV5-8.4-13PB
	67-267008-0A	Rear Panel VIDEO	SECC-N5 T=1.6mm
	80-267008-0	Rear Panel VIDEO	SECC-N5 T=1.6mm
	65-267008-0	Rear Panel VIDEO	SECC-N5 T=1.6mm
	61-023208-0	Self Taping Screw	BTB3X8
PCB-9:DSP BOARD			
CIRCUIT NO.	PART NO.		DESCRIPTION
	PCB INFO		
	A16-31712-21	DSP PCB	VM1.0,FR-4,1.6mm,TG130,216.5x148.5mm
	DIODES		
D5000, D5001	33-20036-00	SCHOTTKY RECTIFIER	SS36
	TRANSISTORS		
Q5001, Q5002	31-00114-05	Digital transistor	DTC114
	IC		
U5009	03-70433-01	Regulator IC	TLV70433DBVR
U5007	03-00004-01	6-Inverter	74AC04
U5003, U5004	03-00153-01	Dual 4-channel Multiplexer	74AC153
U5012, U5025	03-00541-05	Octal Buffer	74AC541
U5001	03-03306-01	2-Bit Bus Switch w/Individual Low Enables	PI5C3306LE
U5002	03-04114-01	SPDIF	AK4114VQ
U5008	03-25081-01	Clock Driver	CDCVF25081D
U5006,U5016	03-00244-01	Octal Buffer	LCX244
U5010	03-38500-01	Linear Regulator	LP38500TS-ADJ
U5011	03-54331-01	DC/DC CONVERTER	TPS54331D
U5015	03-03062-01	MCU	M3062LFGPGP
U5005	03-00734-01	Buffer	NC7NZ34
U5023	03-39800-71	Multi-Purpose Flash	SST39VF800A-70-4C-EKE
U5024	03-39800-72	Multi-Purpose Flash	SST39VF800A-70-4C-EKE
	03-39800-70	Multi-Purpose Flash	SST39VF800A-70-4C-EKE
U5021, U5022	03-00790-01	DSP	D790E001BZDH300
U5014	03-03825-33	Supervisory Circuit	TPS3825

U5019, U5020	03-04832-60	SDRAM	MT48LC2M32B2P-6:G
U5018	03-02416-02	EEPROM	24LC16
U5000, U5017, U5029, U5027	03-00716-01	Buffer	NC7WZ16P6X
U5028	03-00717-01	Buffer	NC7WZ17P6X
U5026	03-00101-00	Digital Temperature Sensor	TMP101
U5030	03-03032-01	CPLD	EPM3032ATC44-10N
	CAPACITOR		
C5028, C5042, C5066, C5077, C5078, C5079, C5080, C5081, C5082, C5083, C5084, C5085, C5086, C5087, C5089, C5090, C5092, C5093, C5095, C5096, C5098, C5099, C5101, C5102, C5104, C5105, C5107, C5108, C5110, C5111, C5112, C5113, C5114, C5115, C5116, C5117, C5118, C5119, C5120, C5121, C5122, C5123, C5124, C5126, C5128, C5129, C5130, C5131, C5132, C5133, C5134, C5135, C5136, C5137, C5138, C5139, C5140, C5141, C5142, C5143, C5144, C5145, C5146, C5147, C5148, C5149, C5150, C5151, C5152, C5153, C5154, C5155, C5156, C5157, C5158, C5159, C5160, C5161, C5162, C5163, C5164, C5165, C5166, C5167, C5168, C5169, C5170, C5171, C5172	26-10451-00	Ceramic Chip Capacitor	100nZ,50V,0603,Y5V
C5007, C5008, C5009, C5010, C5011, C5012, C5013, C5014, C5015, C5016, C5017, C5018, C5019, C5020, C5021, C5022, C5023, C5024, C5031, C5032, C5033, C5034, C5035, C5036, C5037, C5038, C5039, C5040, C5041, C5059, C5060, C5063, C5026, C5058, C5061, C5067, C5068	26-10451-00	Ceramic Chip Capacitor	100n
C5001, C5002, C5003, C5004	26-10251-00	Ceramic Chip Capacitor	1n
C5070	26-15351-00	Ceramic Chip Capacitor	15n
C5064, C5065	26-27051-00	Ceramic Chip Capacitor	27p
C5072	26-22051-00	Ceramic Chip Capacitor	22p
C5005, C5006	26-33051-00	Ceramic Chip Capacitor	33p
C5071	26-22151-00	Ceramic Chip Capacitor	220p
C5175, C5176	26-10251-00	Ceramic Chip Capacitor	1000p
C5029, C5030, C5069	26-22511-01	Ceramic Chip Capacitor	2.2uF
C5048, C5050, C5054, C5055, C5056, C5057, C5046	06-10011-09	SMD Alu Electrolytic Capacitor	10u/16V, 20%, 4*5.4
C5025, C5049, C5052, C5043, C5044, C5045, C5173, C5174	06-10011-11	Chip Tan capacitor	10UF 10V 20%
C5047, C5062	06-22011-05	SMD Alu Electrolytic Capacitor	22UF/16V, 20%, 5*5.4
C5051, C5053	06-47111-06	SMD Alu Electrolytic Capacitor	470u/10V, 20%
C5000, C5027, C5073	06-33160-01	Alu Electrolytic Capacitor	HCM,330uF,6.3V,±20%,105°C,F3.5
	RESISTOR		
R5166, R5172, R5084, R5095, R5096, R5173, R5174, R5188, R5189, R5199	07-90000-00	Chip Resistor	0R, 0603, 1/10W, 5%
R5017, R5094, R5108	07-90104-00	Chip Resistor	100K,0603, 1/10W
R5023, R5024, R5025, R5026, R5027, R5028, R5029, R5030, R5031, R5032, R5033, R5115, R5116, R5177, R5178, R5182, R5183, R5184, R5185, R5186, R5187, R5009, R5010, R5011, R5012, R5013, R5014, R5015, R5167, R5247, R5248, R5249	07-90101-00	Chip Resistor	100R,0603,1/10W,±5%
R5238, R5239, R5240, R5241	07-90102-00	Chip Resistor	1k ,0603, 1/10W, 5%
R5088, R5141, R5142, R5143, R5144, R5145, R5146, R5147, R5148, R5149, R5150, R5151, R5152, R5153, R5154, R5155, R5156, R5208, R5231, R5232, R5233, R5234, R5205 R5206 R5164 R5160	07-90103-00	Chip Resistor	10k ,0603, 1/10W, 5%

R5020, R5022, R5021, R5097, R5135, R5136, R5137, R5139, R5140, R5165, R5168, R5194, R5019, R5034, R5035, R5036, R5037, R5038, R5039, R5040, R5041, R5042, R5043, R5044, R5045, R5046, R5047, R5048, R5049, R5050, R5051, R5052, R5053, R5054, R5055, R5056, R5057, R5058, R5059, R5060, R5061, R5062, R5063, R5064, R5065, R5066, R5067, R5068, R5069, R5070, R5071, R5072, R5073, R5074, R5075, R5076, R5077, R5078, R5079, R5080, R5081, R5082, R5083, R5085, R5086, R5098, R5099, R5100, R5101, R5102, R5103, R5104, R5105, R5106, R5107, R5119, R5120, R5121, R5122, R5179, R5180, R5181, R5195, R5200, R5191, R5222, R5235, R5237, R5242, R5243, R5202, R5203, R5236, R5123, R5124, R5127, R5128, R5129, R5130, R5131, R5132, R5133, R5134, R5138, R5190, R5192, R5193, R5210, R5211, R5212, R5213, R5246, R5169, R5125, R5126, R5223, R5224, R5225, R5220, R5226, R5227	07-90330-00	Chip Resistor	33R,0603,1/10W,±5%
R5117, R5118	07-90122-00	Chip Resistor	1K2,0603,1/10W,±5%
R5113, R5114, R5201, R5204	07-90332-00	Chip Resistor	3K3,0603,1/10W,±5%
R5018, R5109, R5110, R5111, R5112, R5207	07-90472-00	Chip Resistor	4K7,0603,1/10W,±5%
R5001, R5002, R5003, R5004, R5005, R5006	07-97509-00	Chip Resistor	75R,0603,1/10W,±1%
R5209	07-99100-01	Chip Resistor	910Ω, 1/8W,±1%,RC0805FR-07910RL
R5197	07-95101-01	Chip Resistor	5.1K,0805,1/8W,±1%
R5091	07-95901-01	Chip Resistor	5.9K,0805,1/8W,±1%
R5092	07-91002-01	Chip Resistor	10K 1% 0805, 1/8W
R5093	07-91602-01	Chip Resistor	16K 1% 0805, 1/8W
R5016	07-91802-01	Chip Resistor	18K 1% 0805, 1/8W
R5090	07-92702-01	Chip Resistor	27K,0805,1/8W,±1%
R5198	07-96492-01	Chip Resistor	64.9K,0805,1/8W,±1%
R5089	07-91103-01	Chip Resistor	110K,0805,1/8W,±1%
R5196	07-93323-01	Chip Resistor	332K,0805,1/8W,±1%
RP5001, RP5002	07-90330-10	Chip Resistor Network	33R,0603
	INDUCTOR		
L5001, L5002	08-04101-06	RF Choke	100uH ±10% 40mA
L5001, L5002	or08-04101-00	Inductor SMD	100uH,1210
L5003, L5004	08-04100-02	Inductor SMD	10uH, ±10%, 0805
L5005	08-04479-01	Inductor SMD	SDR0805-4R7ML
FB5001, FB5002, FB5003, FB5004,FB5006, FB5007	08-04221-01	Ferrit Bead	220R100M
	CRYSTALS		
Y5001	04-11102-01	Crystal	11.059MHz, 49SMD
Y5000	04-22452-01	Crystal	HLX-0-3-5-24.576M-50-0070-2-TR
	IC		
OP5001, OP5002, OP5003, OP5004	17-06001-07	Optical Receive	DLR2180/25M
OP5005, OP5006	03-01180-01	Optical Transmission	DLT1180A-2(25M)
OP5005, OP5006	or 03-00147-00	Optical Transmission	TOTX147L(25M,F,T)
	TRANS		
T5005, T5006	22-82005-00	Common Inductor	T8-20/5-1.8mH
T5005, T5006	or22-22801-20	TRANS	PT-10(HKS-999-115)
T5001, T5002, T5003, T5004	22-82020-01	Common Inductor	T8-20/20-1.8mH
T5001, T5002, T5003, T5004	or22-22800-07	TRANS	PT-10(2280-T007)
	CONNECTOR		
	67-151010-1A	Rear Panel DSP	SECC-N5 T=1.6mm
	80-151010-1	Rear Panel DSP	SECC-N5 T=1.6mm
	65-151010-1	Rear Panel DSP	SECC-N5 T=1.6mm
	61-023208-0	Self Taping Screw	BTB3X8
CN5001	13-12506-15	Connector	2.54mm, 2x3Pin, CNT-M254-2*3-GS-5.8/3-N
J5003	13-12502-19	Connector	2.54mm, 2Pin, CNT-M254-1*2-GS-5.6/3-N
J5004 J5006 J5007	13-22514-10	Connector	2.54mm, 2*7Pin
J5005	17-01002-13	2RCA	AV2-8.4-13PB1
J5001	17-01004-19	4RCA	AV4-8.4-13
PCB-10:FPP BOARD			
CIRCUIT NO.	PART NO.		DESCRIPTION

	PCB INFO		
	A16-31705-21	FPP PCB	VM1.0,FR-4,1.6mm,TG130,200*65mm
	TRANSISTORS		
Q7000,Q7001	31-00114-01	Transistor	DTA114EKA
Q7002,Q7003	31-00114-05	Digital transistor	DTC114EKAT146
	IC		
U7005	03-01503-00	MCU	PIC16LF1503T-I/ST
U7004	03-00244-05	Octal Buffer	SN74HCT244DWR
U7002	03-00244-01	Octal Buffer	SN74LVC244ADWR
U7000	03-01117-33	Linear Regulator	AMS1117-3.3
U7001	03-70433-01	Regulator IC	TLV70433DBVR
U7006	03-00734-01	Buffer	NC7NZ34K8X
	CAPACITOR		
C7012, C7001, C7008, C7004, C7005, C7021, C7026	26-10451-00	Ceramic Chip Capacitor	100nZ,50V,0603,Y5V
C7017, C7018, C7022,C7023	26-22351-00	Ceramic Chip Capacitor	22nK,50V,0603,X7R
C7015	06-22011-05	SMD Alu Electrolytic Capacitor	VSS or CS series, 22uF,16V,±20%,5x5.4
C7000, C7006, C7007,C7020, C7027	06-10011-09	SMD Alu Electrolytic Capacitor	VSS/CS/VES Series,10uF,16V,±20%,85 °C
	RESISTOR		
R7000, R7001, R7002, R7003,R7004, R7018, R7019, R7020,R7021, R7022, R7023, R7024	07-90330-00	Chip Resistor	33Ω,0603,1/10W,±5%,RC0603JR-0733RL
R7025, R7026	07-90101-00	Chip Resistor	100Ω,0603,1/10W,±5%,RC0603JR-07100RL
R7011	07-90223-00	Chip Resistor	22KΩ,0603,1/10W,±5%,RC0603JR-0722KL
R7028, R7030, R7031	07-90101-00	Chip Resistor	100Ω,0603,1/10W,±5%,RC0603JR-07100RL
	CONNECTOR		
J7000	13-21004-01	FPC Connector SMD	1.0mm, 4Pin,GL76S05-04
J7003	13-21020-05	FPC Connector SMD	1.0-9-20PWB
CON7002	13-22006-01	Connector Socket	CON2MM/6P,DIP
CON7001	14-32220-11	Cable	2.54mm, 10*2pin, L=230mm
FPP to Encoder board	14-11506-02	CABLE	UL2468#26AWG,L=100mm
J7001	13-22003-01	Connector Socket	PH 2.0A-3AW
	STRUCTURAL PARTS		
	70-267013-0	SPACER	
CONNECT J7001 AND J7002	14-11503-10	CABLE	UL2547#26AWG,L=100mm
PCB-11:LED BOARD			
CIRCUIT NO.	PART NO.		DESCRIPTION
	PCB INFO		
	A16-31706-22	LED PCB	VM2.0,FR-4,1.6mm,TG130,56*50mm
	DIODES		
D7000,D7001,D7002	33-50603-90	white ChipLED	WR-PB1608UW-G-M23
	RESISTOR		
R7029	07-90471-00	Chip Resistor	470Ω,0603,1/10W,±5%,RC0603JR-07470RL
R7012, R7017, R7027	07-90751-01	Chip Resistor	230Ω,0603,1/10W,±5%,RC0603JR-07230RL
	CONNECTOR		
D7003	33-50565-01	LED	φ5, BL-BB5JC274
J7002	13-22003-01	Connector Socket	PH 2.0A-3AW
PCB-12:TOUCH KEY BOARD			
CIRCUIT NO.	PART NO.		DESCRIPTION
	PCB INFO		
	A16-31707-21	Touch Key PCB	VM1.0,FR-4,1.6mm,2 LAYERS,1OZ,TG130,50*15mm
	IC		
U7003	03-02044-02	four button capsense controller	CY8CMBR2044-24LKXI
	CAPACITOR		
C7016	26-10451-00	Ceramic Chip Capacitor	100n ,0603
C7014	26-10611-20	Ceramic Chip Capacitor	10uF,10V,0603,X5R,±20%
C7013	26-22251-00	Ceramic Chip Capacitor	2n2K,50V,0603,X7R
	RESISTOR		
R7006, R7007, R7008, R7009	07-90000-00	Chip Resistor	0Ω, 0603, ±5%

R7010	07-90561-00	Chip Resistor	560Ω,0603,1/10W,±5%,RC0603JR-07560RL
R7005	07-90103-00	Chip Resistor	10K,0603
	CONNECTOR		
J1	13-21004-01	FPC Connector SMD	1.0mm, 4Pin,GL76S05-04
	14-31704-01	Cable	FFC, PH1.0, 1*4P, L=50mm, 1.0*4*50*A(4/4/8/8)
PCB-13:ENCODER BOARD			
CIRCUIT NO.	PART NO.		DESCRIPTION
	PCB INFO		
	A16-31708-21	ENCODER PCB	VM1.0,FR-4,1.6mm,TG130,60*28mm
	CAPACITOR		
C7002,C7003	26-10451-00	Ceramic Chip Capacitor	100n ,0603
C7009, C7010	26-10351-00	Ceramic Chip Capacitor	10n,0603
C7011, C7024, C7025	26-22351-00	Ceramic Chip Capacitor	22n,0603
	RESISTOR		
R7015, R7016	07-90122-00	Chip Resistor	1K2,0603
R7013, R7014	07-90103-00	Chip Resistor	10K,0603
	CONNECTOR		
CON7003	13-22006-00	Connector Socket	CON2MM/6P,DIP
V7001	28-00160-02	Encoder	RE160F-40E3-20A-24P-N
PCB-14:LED DRIVER BOARD			
CIRCUIT NO.	PART NO.		DESCRIPTION
	PCB INFO		
	A16-31710-22	LCD DRIVER PCB	VM2.0,FR-4,1.6mm,4 LAYERS,1OZ,G130,152.2*65.5mm
	IC		
U1	03-00695-01	MCU	PIC32MX695F512L-80I/PF
U2	03-25616-01	SRAM	IS61WV25616BLL-10TL
U7	03-05724-01	WHITE LED STEP-UP CONVERTER	AP5724WG-7
	DIODES		
D3	33-34013-01	Diode Schottky	B340LA-13-F
	RESISTOR		
R20, R22, R23, R24, R25, R26, R27, R28, R29, R30, R31, R32, R33, R34, R35, R36, R37, R38	07-90000-08	Chip Resistor	0R 0402
R2, R3, R4, R7, R18, R19, R39, R40, R44, R48	07-90000-00	Chip Resistor	0Ω, 0603, ±5%
R15, R49	07-90102-00	Chip Resistor	1KΩ,0603,1/10W,±5%,RC0603JR-071KL
R11, R12	07-90472-00	Chip Resistor	4.7KΩ,0603,1/10W,±5%,RC0603JR-074K7L
R16	07-90512-00	Chip Resistor	5.1KΩ,0603,1/10W,±5%,RC0603JR-075K1L
R1, R13, R14	07-90103-00	Chip Resistor	10KΩ,0603,1/10W,±5%
R50	07-90104-00	Chip Resistor	100KΩ,0603,1/10W,±5%,RC0603JR-07100KL
R8	07-93308-01	chip resisitor	3.3Ω,0805,1/8W,±1%, RC0805FR-073R3L
R45	07-90470-01	Chip Resistor	47Ω,0805,1/8W,±5%,RC0805JR-0747RL
R46	07-90000-01	Chip Resistor	0Ω,0805,1/8W,±5%
	CAPACITOR		
C1, C2, C3, C4, C5, C6, C7, C8, C9, C10, C11, C14, C20, C22, C24, C28, C29, C30, C31, C33	26-10451-00	Ceramic Chip Capacitor	100N,0603,50V,Y5V
C15, C16	26-22051-00	Ceramic Chip Capacitor	22pJ,50V,0603,NPO
C21	26-47411-10	Ceramic Chip Capacitor	470nK,16V,0603,X7R
C19	26-10511-10	Ceramic Chip Capacitor	0603, 1uF, 16V, X5R, ±10%
C23	26-22560-10	Ceramic Chip Capacitor	2.2uF,0603,6.3V,X5R,CC0603KRX5R5BB 225
C12	26-22521-21	Ceramic Chip Capacitor	2.2uF,± 10%,25V,X7R,0805,GRM21BR71E225KA
C13	26-47611-02	Ceramic Chip Capacitor	47uK,10V,1206,X5R,GRM31CR61A476M E15L

C25, C26, C32, C34	26-10611-02	Ceramic Chip Capacitor	1206, 10uF, 16V, X5R, ±10%
	INDUCTOR		
L1	08-04220-14	Inductor SMD	744032220,22uH,±10%,1210
	CRYSTAL		
Y1	04-18001-04	Crystal SMD	8MHz,CL=18PF,FL=20PPM
	CONNECTOR		
J1	13-20540-01	FPC Connector	40Pin,0.5mm,0.5S-1S-40PWB
J7	13-20519-00	FPC Connector	FH19C-4S-0.5SH
J8	13-20508-01	FPC Connector	FPC PH0.5 8P
J115	13-21020-05	FFC SOCKET	1.0-9-20PWB
U12	03-34838-00	IR Receiver	TSOP34838
CONNECT J115 AND J7003	14-00520-00	Cable	1.0mm,20pin,L=50mm,0.1x0.65
	66-017004-0	IR Bracket	TIN Plate t=0.3mm
	79-382001-0	Gasket	14x9x8mm
PCB-15:PSU BOARD A			
CIRCUIT NO.	PART NO.		DESCRIPTION
	PCB INFO		
	A16-31711-21	PSU PCB A	VM1.0 FR-4,1.6mm,TG130, 113x180mm
	DIODES		
D8001, D8024, D8025	33-44148-17	Switch Diode	1N4148W-NR
DW8001	33-11800-30	Zener Diode	18V, 3W, ±5%, SMB
D8006	33-20001-01	Diode	M1
D8005	33-20036-00	Schottky Rectifier Diode	SS36B
D8004	33-20056-00	Schottky Rectifier Diode	SK56C
D8002	33-20150-01	Ultrafast Rectifier	SBR20A150CT
D8003	33-22007-00	Rectifier Diode	UG2007
D8000	33-30862-00	Rectifier Bridge	KBU806,8A/600V
	TRANSISTORS		
Q8002, Q8004	31-03326-01	NPN TRANS	2SC3326A
Q8003, Q8007	31-00114-01	Transistor	DTA114EKA
Q8006	31-02878-01	Transistor	2SC2878 TO-92
Q8001	31-05210-00	MOSFET	IRF5210 TO-220
	IC		
U8008	03-05171-03	DC-DC CONVERTER	CS5171EDR8G
U8006	03-22670-01	DC-DC CONVERTER	LM22670MR-ADJ
U8088	03-00266-01	Power controller IC	TOP266EG
U8002, U8007	A03-00817-11	Photo Coupler	EL817(B)-F
U8004	03-00431-02	Voltage Norm	TL431
U8005	03-07805-10	Voltage Regulators	KA78R05
	RESISTOR		
R8017	07-92700-01	Chip Resistor	270Ω ,0805,1/8W,±1%
R8061	07-91131-01	Chip Resistor	1.13KΩ,0805,1/8W,±1%,RC0805
R8033	07-99530-01	Chip Resistor	953Ω ,1/8W,±1%,RC0805FR-07953RL
R8018	07-92701-01	Chip Resistor	2.7KΩ ,0805,1/8W,±1%
R8021	07-92871-01	Chip Resistor	2.87KΩ ,0805,1/8W,±1%
R8012	07-93301-01	Chip Resistor	3.3KΩ ,0805,1/8W,±1%
R8020	07-93001-01	Chip Resistor	3KΩ,0805,1/8W,±1%,RC0805FR-073KL
R8060	07-94991-01	Chip Resistor	4.99KΩ ,0805,1/8W,±1%
R8049	07-92741-01	Chip Resistor	2.74KΩ ,0805,1/8W,±1%
R8045	07-99531-01	Chip Resistor	9.53KΩ,0805,1/8W,±1%,RC0805
R8009	07-96801-01	Chip Resistor	6.8KΩ,0805,1/8W,±1%,RC0805FR-076K8L
R8050	07-90109-01	Chip Resistor	1Ω ,0805,1/8W,±5%
R8010	07-90689-01	Chip Resistor	6.8Ω ,0805,1/8W,±5%
R8030, R8031	07-90101-01	Chip Resistor	100Ω ,0805,1/8W,±5%
R8022	07-90221-01	Chip Resistor	220Ω ,0805,1/8W,±5%
R8051, R8052	07-90331-01	Chip Resistor	330Ω ,0805,1/8W,±5%
R8059	07-90681-01	Chip Resistor	680Ω ,0805,1/8W,±5%
R8019, R8027	07-91001-01	Chip Resistor	1KΩ ,0805,1/8W,±1%
R8024	07-90102-01	Chip Resistor	1KΩ,0805,1/8W,±5%
R8005, R8079, R8025	07-90103-01	Chip Resistor	10KΩ,0805,1/8W,±5%
R8011	07-90000-02	Chip Resistor	0Ω, 1206, 1/4W, ±5%
R8004	07-90270-02	Chip Resistor	27Ω,1206,1/4W,±5%,RC1206JR-0727RL
R8013, R8014, R8015	07-90102-02	Chip Resistor	1KΩ,1206,1/4W,±5%
R8006, R8008, R8038, R8040	07-90105-02	Chip Resistor	1MΩ,1206,1/4W,±5%,RC1206JR-071ML
R8000, R8001, R8002	07-90335-02	Chip Resistor	3.3MΩ,1206,1/8W,±5%,RC1206JR-073M3L
R8083	07-90184-01	Chip Resistor	180KΩ,0805,1/8W,±5%,RC0805JR-07180KL
R8084	07-90229-02	Chip Resistor	2.2Ω,1206,1/4W,±5%,RC1206JR-072R2L
R8081,R8080,R8082	07-90515-02	Chip Resistor	5.1M, 1206, ±5% RC1206JR-075M1L
R8003	07-30683-04	Metal Oxide film Resistor	RY21.68KΩ, 2W, ±5%
ZV8000	07-70471-03	TVS	TUR10D471

TH8000	07-70050-02	NTC	5D-11
JP8006	21-06500-00	Jumper	L=5mm
JP8005, JP8007	21-06500-00	Jumper	L=5mm
	A14-31702-00	Wire	UL1672#18AWG, L=90mm
	CAPACITOR		
C8035, C8117	26-10151-01	Ceramic Chip Capacitor	0805,100PF, 50V, NPO
C8002	26-68151-02	Ceramic Chip Capacitor	680pJ,50V,1206,NPO,C3216C0G1H681J T
C8025	26-33151-01	Ceramic Chip Capacitor	330pJ,50V,0805,NPO
C8021, C8022, C8036	26-10351-01	Ceramic Chip Capacitor	10nK,50V,0805,X7R
C8033, C8040	26-22351-01	Ceramic Chip Capacitor	22nK,50V,0805,X7R
C8003, C8004, C8005, C8006, C8014, C8018, C8030, C8013	26-10451-01	Ceramic Chip Capacitor	100nK,50V,0805,X7R
C8029, C8031	26-10621-12	Ceramic Chip Capacitor	10uF,25V,±10%,1206,X5R
C8080	26-33262-02	Chip Resistor	3.3nK,630V,1206,X7R,C3216X7R2J332K
CX8002	A25-10422-07	Interfernece Suppression Cap	MPX,0.1uF/275V,13mm*6mm,10%,Pitch=
CX8000	A25-47422-08	Interfernece Suppression Cap	MPX,470nF,275VAC,X2,±
C8007, C8008,CY8000	A05-10242-00	Hign Voltage Cermatic Capacitor	1nF, 400V(X1), 250V(Y1), ±5%
C8010	05-10113-00	High Voltage Cermatic Capacitor	100pF, 10%, 1KV,
C8001	05-47213-00	High Voltage Ceramic Capacitor	4.7nF,1KV,±10%,CT81-1KV-12b-2B4-472KT5B
C8012	06-10051-02	Alu Electrolytic Capacitor	CD263(X), 10uF,50V, ±20%
C8011	06-47021-02	Alu Electrolytic Capacitor	CD263(X), 47uF,25V, ±20%
C8015, C8016, C8017	06-22211-06	Alu Electrolytic Capacitor	CD284, 2200uF, 16V, ±20%, 105 °C, F5.0
C8020	06-10221-03	Alu Electrolytic Capacitor	CD289,1000uF,25V,±20%,10x30,F5.0
C8032	06-33160-01	Alu Electrolytic Capacitor	HCN,330uF,6.3V,±20%,105 °C,F3.5
C8019, C8118	06-33021-01	Alu Electrolytic Capacitor	CD284, 33uF, 25V, ±20%,105 °C, F5.0
C8027, C8028	06-10121-10	Alu Electrolytic Capacitor	CD289,100uF,25V,±20%,105 °C,F2.5
C8009	06-10142-04	Alu Electrolytic Capacitor	CD294,100uF,400V,±20%, 105 °C
	INDUCTOR		
L8003, L8005	19-35980-00	INDUCTOR	3-5uH
L8001, L8002	22-00016-26	INDUCTOR	HJ-7.0mH*2,T16x12x8C
L8000	08-02809-01	INDUCTOR	R0625-8uH
L8006	22-00600-00	INDUCTOR	60uH/3A
L8004	08-05220-01	INDUCTOR	R0603-22uH, 22uH
L8088	19-35980-00	Inductor	FB F10 RHW 3.5*8.3*0.8-T
	TRANSFORMER		
T8000	A22-00028-05	Transformer	HJ-M17-EER28
	RELAYS		
K8001	A12-02101-01	POWER RELAY	DH1U 15A/250V 5V
	CONNECTOR		
AC inlet to chassis	A14-11501-00	CABEL	UL1672#18AWG L=55mm
CON8016	A17-07103-02	AC Inlet	R-30190(C54)
CON8017	A17-07002-21	AC outlet	RG-201
CON8017	A17-07002-16	AC outlet	SS-6C
CON8002	13-22508-00	SOCKET	XHB-2.5A-8A
CON8003	13-23904-30	Connector	B4P-VH
CON8015	13-23902-30	Connector	B2P-VH
CON8000 CON8004	13-23903-01	Connector	7.92A-2A VH
CON8001	13-23907-01	Connector Socket	LD7.92-4A
	FUSE		
F8002, F8003	A20-20000-01	FUSE HOLDER	HF-003-1
F8003	A20-12102-00	FUSE	T1A/250V
F8003	A20-12501-00	FUSE	T500mA/250V
F8002	A20-12202-00	FUSE	T2A/250V
F8002	A20-12102-00	FUSE	T1A/250V
	MECHANICAL PARTS		
Q8001(H8003) U8005(H8001)	70-004001-0	Heat sink	
MUR1620	70-048015-0	Heat sink	Heatsink D
TOP266	70-267014-0	PSU Heatsink	6063 T5
	85-211001-0	Parts Housing	PTB, TC-21
	61-023510-0	Machine Screw	MB3x10
	62-010302-0	Nut	GB6170, M3
AC INLET	61-023206-0	Self Taping Screws	BTB3x6
	61-373506-0	Self Taping Screws	M3x6
	69-135001-0	Copper Spacer	M3 L=10mm
PCB-16:PSU BOARD B			
CIRCUIT NO.	PART NO.		DESCRIPTION
	PCB INFO		
	A16-31713-21	PSU PCB B	VM1.0 FR-4,1.6mm,TG130
	DIODES		
D8021, D8023	33-44148-00	Switch Diode	1N4148 DO-35

D8007	33-13609-00	Zener Diode	3V6, 1/2W, DO-35
D8008	33-16209-00	Zener Diode	6V2, 1/2W, DO-35
D8018	33-13900-02	Zener Diode	39V, 1/2W, DO-35
D8010, D8013, D8026	33-24001-00	Rectifier Diode	1N4001 DO-41
D8017	33-30142-00	Rectifier Bridge	DB104 DIP4
D8027 D8028 D8029 D8030 D8031 D8032 D8033 D8034 D8035 D8036 D8037 D8037	33-25393-00		1N5393
	TRANSISTORS		
Q8008 Q8016 Q8017 Q8018	31-02690-00	Transistor	KSC2690AYSTU TO-126
Q8013 Q8014 Q8009 Q8010 Q8011 Q8012	31-01266-00	Transistor	KTA1266-GR-AT/P
	IC		
U8012, U8013, U8015	03-00431-02	Shunt Regulator	TL431 TO-92
IC8000	A03-00817-11	Photo Coupler	EL817(B)-F
	RESISTOR		
R8078	07-20229-51	Metal Film Resistor	2.2Ω, 1/4W, ±5%
R8082 R8083 R8084	07-26809-51	Metal Film Resistor	68Ω, 1/4W, ±1%
R8032, R8080, R8081, R8093	07-20101-51	Metal Film Resistor	100Ω, 1/4W, ±5%
R8063, R8064	07-24991-51	Metal Film Resistor	4.99KΩ, 1/4W, ±1%
R8055	07-20392-51	Metal Film Resistor	3.9KΩ, 1/4W, ±5%
R8065, R8066 R8088	07-21101-51	Metal Film Resistor	1.1KΩ, 1/4W, ±1%
R8062	07-22211-51	Metal Film Resistor	2.21KΩ, 1/4W, ±1%
R8089	07-22431-51	Metal Film Resistor	2.43KΩ, 1/4W, ±1%
R8085 R8086 R8087 R8090 R8091 R8092	07-22701-51	Metal Film Resistor	2.7KΩ, 1/4W, ±1%
R8026	07-20103-51	Metal Film Resistor	10KΩ, 1/4W, ±5%
R8077	07-20153-51	Metal Film Resistor	15KΩ, 1/4W, ±5%
R8069, R8070, R8071	07-50228-10	Fusible Resistor	0.22Ω, 1/4W, ±10%
	CAPACITOR		
C8126 C8048, C8053	06-10051-01	Alu Electrolytic Capacitor	CD263(X), 10uF, 50V, ±20%, F5.0
C8125	06-10061-02	Alu Electrolytic Capacitor	CD263(X), 10uF, 63V, ±20%, 105°C, F5.0
C8111	06-10111-03	Alu Electrolytic Capacitor	CD263X, 100uF, 16V, ±20%, D=5, F5.0
C8041 C8054 C8055 C8058 C8059 C8122	06-10121-02	Alu Electrolytic Capacitor	CD263(X), 100uF, 25V, ±20%
C8104	06-10211-01	Alu Electrolytic Capacitor	CD263X, 1000uF, 16V, ±20%, D=10, F5.0
C8108, C8109	06-10151-04	Alu Electrolytic Capacitor	CD263(X), 100uF, 50V, ±20%, F5.0
C8112	06-33161-00	Alu Electrolytic Capacitor	CD263, 330uF, 63V, ±20%, F5.0
C8062, C8063	06-10221-01	Alu Electrolytic Capacitor	CD263X, 1000uF, 25V, ±20%, F5.0
C8066, C8119	06-47221-01	Alu Electrolytic Capacitor	CD263, 4700uF, 25V, ±20%, 105
C8044, C8045, C8046, C8047	06-47231-01	Alu Electrolytic Capacitor	CD263, 4700uF, 35V, ±20%, 105
C8026, C8120, C8121, C8127	24-10312-00	Monolithic Capacitor	10n, 100V, ±20% F5.0
C8056, C8057, C8060, C8061, C8071, C8074, C8037, C8038, C8039, C8043, C8115, C8116	25-10412-04	Metallized Polyester Film	CL23B, 100nF, 100V, ±5%, Pitch=5mm
	25-22312-06	Metallized Polyester Film	CL23B, 22nF, 100V, ±5%, Pitch=5mm,
	CONNECTOR		
	13-10001-22	Test Pin	CNT-M254-1*1-GS-GS-6/3-N
CON8018	13-22502-00	Connector Socket	XHB2.5A-2A
CON8004	13-22504-00	Connector Socket	XHB-2.5A-4A
CON8014	13-22505-00	Connector Socket	XHB-2.5A-5A
CON8005, CON8006, CON8010	13-23906-00	Connector Socket	VH 3.96A-6A
	FUSE		
F8004, F8005, F8006	A20-12162-01	FUSE	061801.6MXP, T1.6AL/250V
FC8003, FC8004, FC8005, FC8006, FC8007,	20-20000-00	Fuse Holder	HF-004
	METAL PARTS		
H8005, H8006, H8004(KSC2690)	70-111003-1	Heatsink C	6063-T5, Black
H8002(KSC2690)	70-004001-0	Heat Sink	HS4-C350-B009V1-M008
	61-023208-0	self tapping screw	BTB3X8
D8027 D8028 D8029 D8030 D8031 D8032	76-000001-0	Teflon	18AWG-L
PCB-17:TRIGGER BOARD			
CIRCUIT NO.	PART NO.		DESCRIPTION
	PCB INFO		
	A16-11509-21	TRIGGER PCB	VM1.0 FR-4,1.6mm,TG130, 53mmX108mm
	DIODES		
D9000, D9001, D9002, D9003, D9004, D9005, D9006, D9007, D9008	33-40352-01	Diode	1SS352
	TRANSISTORS		
Q9012, Q9013, Q9014, Q9015	31-00114-01	Transistor	DTA114, SOT23, Tape
Q9000, Q9001, Q9005, Q9006, Q9007, Q9008, Q9009, Q9010, Q9011	31-00114-05	Transistor	DTC114, SOT23, Tape
Q9002, Q9003, Q9004	31-01220-00	Transistor	KSA1220A-Y
	IC		
U9000	03-03221-02	RS232 Interface	MAX3221CAE, SSOP, Tube
	CAPACITOR		
C9019, C9020	26-10151-11	Low ESL Feed Through	EMI100p Low ESL Feed Through,0805,X5R,100p,50V,Tape
C9001, C9002, C9003, C9004	26-47051-00	Ceramic Chip Capacitor	47P,0603,50V,NPO
C9000	26-47251-00	Ceramic Chip Capacitor	4n7K,50V,0603,X7R
C9005, C9006, C9007, C9008, C9009, C9010	26-10451-00	Ceramic Chip Capacitor	100N,0603,50V,Y5V
C9011, C9012, C9013	26-47451-00	Ceramic Chip Capacitor	470N,0603,50V,Y5V
C9016	26-22351-01	Ceramic Chip Capacitor	22N,0805,50V,X7R
C9018	06-10951-02	ALU Electrolytic CAP	CD110, 1u, 50V, 20%, D=5, Pitch=2

C9015	06-10111-04	ALU Electrolytic CAP	CD110,100u,16V,20%,D=5,Pitch=2,Pin Length=5
	RESISTOR		
R9021	07-90100-00	Chip Resistor	10R,0603,1/10W,±5%
R9013, R9014, R9015, R9016, R9017, R9018	07-90399-00	Chip Resistor	3.9Q,0603,1/10W,±5%,RC0603
R9003, R9004, R9005, R9006	07-90101-00	Chip Resistor	100Q,0603,1/10W,±5%
R9000	07-90102-00	Chip Resistor	1K,0603,1/10W,±5%
R9002	07-90222-00	Chip Resistor	2.2K,0603,1/10W,±5%
R9007, R9009, R9010, R9011, R9023	07-90103-00	Chip Resistor	10K,0603,1/10W,±5%
R9012	07-90333-00	Chip Resistor	33K,0603,1/10W,±5%
R9019	07-90104-00	Chip Resistor	100K,0603,1/10W,±5%
R9020, R9022	07-90100-01	Chip Resistor	10R,0805,1/8W,±5%
	CONNECTOR		
J9005	17-08009-00	RS232 Socket	RS232 RS232/FS
J9000	17-02001-04	Ear Jack	ST-323B-04 / CKX-3.5-02-3P
J9001, J9002, J9003, J9004	17-02002-07	Ear Jack	SJ-3541-5P
J9001, J9002, J9003, J9004	or17-02002-02	Ear Jack	SCJ351-DS SW 3.5mm, Double Single CH, SW
TRIGGER CON9000 TO IO CON6006	14-11520-00	CABLE	UL2651#28AWG*20P , L=380mm
CON9001	13-12503-15	Header	GL27S01-03-C2B-13.0/3.0, 2.54, 3Pin
	61-023208-0	Self Tapping Screw	BTB3x8
	85-151001-0	Spacer	Nylon66,H=17
	69-355002-0	Touch Key Copper plate	T2Y2 T=0.2mm
	14-31701-00	WIRE	UL1007#26AWG,L=50mm
PCB-18:SWITCH BOARD			
CIRCUIT NO.	PART NO.		DESCRIPTION
	PCB INFO		
	A16-11511-21	SWITCH BOARD	VM1.0 FR-4,1.6mm,TG130, 26mmX30mm
	CONNECTOR		
CON9002	13-22503-24	Connector Socket	GL37S01-3-C-3.1
S1	11-05102-01	Slide Switch	TS-13P-A1-2-Q
MECHANICAL PARTS			
PSUA to connect board	14-11504-00	CABLE	UL1569#16AWG,L=180mm
PSUA to connect board	14-11508-00	CABLE	UL1569#22AWG ,L=250mm
PSUA to power switch	A14-11502-01	CABLE	UL1672#18AWGL=100mm
PSUB to connect board	14-11502-02	CABLE	UL1569#24AWG ,L=120mm
PSUB to connect board	14-11506-00	CABLE	UL1569#18AWG,L=240mm
PSUB to connect board	14-11506-01	CABLE	UL1569#18AWG ,L=120mm
	A18-15050-00	R Type Transformer	R50-E9795G
	JA15-15120-00	AC Cord	LP30B & LS13 SVT 18AWG 105C Black 3C L=1800mm
	or A15-26121-10	AC Cord	3UT22/3GTJA
	or A15-17121-10	AC Cord	T172-AH
	JA15-16250-03	AC Cord	LP34&LS-60 H05VV-F 0.75mm2 3C Black L=1800mm
	or A15-86251-20	AC Cord	3VTJ1&3VTJA, H05VV-F 3G 0.75mm2, L=2000mm, Black
	or A15-17251-20	AC Cord	T172-C
LCD			
	J23-08253-00	LCD Display	UMSH-8868MD-2T
SWITCHS			
	A11-01101-03	Rocker Switch	RF-1003-BB2, TV-5
METAL PARTS			
	70-267007-1	Main Top Cover	6063 T5
	70-267008-0	Second Top Cover	Al1050 T=3.0mm
	67-267004-0	Perf Sheet	SPCC, T=0.5mm,Black Painting
	67-267001-1	Bottom	SECC-N5 T=1.2mm,
	65-267001-1	Bottom	SECC-N5 T=1.2mm,
	67-267009-0	Bracket	SECC-N5 T=1.0mm
	65-267009-0	Bracket	SECC-N5 T=1.0mm
	67-267010-0	Middle Bracket	SECC-N5 T=1.0mm
	65-267010-0	Middle Bracket	SECC-N5 T=1.0mm
	67-267002-3C	Rear Panel(C)	SECC-N5 T=1mm
	80-267002-3	Rear Panel(C)	SECC-N5 T=1mm
	65-267002-3	Rear Panel(C)	SECC-N5 T=1mm
	67-267006-2B	Rear Panel(AH)	SECC-N5 T=1mm
	80-267006-2	Rear Panel(AH)	SECC-N5 T=1mm
	65-267006-2	Rear Panel(AH)	SECC-N5 T=1mm

	70-267901-0	Fascia ASSY	
	(70-267004-0A)	Center Front Fascia	AL 6063 T5
	(70-267002-0A)	Left Front Fascia	AL 6063 T5
	(70-267003-0B)	Right Front Fascia	AL 6063 T5
	(70-267001-0)	Rear Fascia	AL 6063 T5
	61-224510-1	Hex Screws	GB/T70.1, HM4x10
	61-063506-0	Machine Screw	MF3x6
	67-355008-0	Fascia Connect Sheet	SECC N5 T=1.2mm, Painting Black
	65-355008-0	Fascia Connect Sheet	SECC N5 T=1.2mm
	70-267005-1	Left Side Panel	AL 6063 T5
	79-355001-0	Expanded Rubber	IEPE Foam, Black, 318mmx12mmx0.5mm
	70-267006-0	Right Side Panel	AL 6063 T5
	67-267005-0	Vent sheet	Stainless Steel, T=0.5mm,Black Painting
	67-267011-0	CONNECT PCB COVER	SECC-N5 T=1.0mm
	65-267011-0	CONNECT PCB COVER	SECC-N5 T=1.0mm
	70-151004-0	Spacer	AL, 3mm
	J71-267001-1	Vol. Knob Assy	
	J71-267002-0	Masters II Feet	
	71-267003-0	Feet Shoe Assy	
	J71-267903-0	Masters II Feet Shoe	
	78-267001-0	Feet PAD	Poron MX-48HF BLACK
	67-355011-0	Logo Clamp	SECC N5 T=1mm,Painting Black
	65-355011-0	Logo Clamp	SECC N5 T=1mm
	67-355012-0	Logo Clamp Mirror	SECC N5 T=1mm,Painting Black
	65-355012-0	Logo Clamp Mirror	SECC N5 T=1mm
PLASTIC			
	J71-355001-0A	NAD Logo	NAD logo,Pantone cool 6C
	96-355001-0A	Touch Key Cap	18*6*2
	85-151002-0	PCB Guide	CG-500
	B75-267001-0	LCD Bracket	ABS
FASTENERS			
	J61-234510-1	Machine Screws	M4X10
	63-010309-5	Plain Washer	φ3xφ9.5mm
	61-023106-0	Self Taping Screw	STB3X6
CONNECT PCB(5)	61-023110-0	Self Taping Screws	STB3X10
FPP(4)	61-023215-0	Self Taping Screws	BTB3X15
Touch Key Board (2) , Logo Clamp (4) ,Logo PCB (2)	61-023206-0	Self Tapping Screw	BTB3x6
	61-033208-0	Self Tapping Screw	BTP3x8
	61-022205-6	Self Tapping Screw	BTB2.6x5
	61-023208-0	Self Tapping Screw	BTB3X8
	61-023506-0	Machine Screw	MB3x6
	61-024506-0	Machine Screw	MB4x6
	61-024106-0	Self Tapping Screw	STB4x6
	61-034508-0	Machine Screw	MP4X8
	63-020411-0	Spring Washers	GB93φ4
	61-373506-0	Self Taping Screws	M3x6
ACCESSORIES			
	84-005001-0	Nilon Cable Tie	YJ-100
	86-355001-0	Adhesive tape	3M 9448,T=0.1mm

PACKING

	88-267001-0A	Carton Box	
	88-355011-0	Paper Corner	50*50*5mm, L=260mm
	89-355901-0	Cushions Assy	
	88-355005-0A	Paper Formed Box	
	88-355006-0	Cushion First Layers	525*480*7mm

	88-355007-0	Cushion Second Layers	525*480*7mm
	88-355008-0	Cushion Third Layers	525*480*7mm
	88-355009-0	Cushion Forth Layers	525*480*7mm
	88-355010-0	Cushion Last Layers	525*480*7mm
	89-355001-0	Main Pulp	523mmX478mmX92.5mm
	89-355003-0	Accessory Pulp	286mmX180mmX47mm
	89-355004-0	Shoe Cover Pulp	118mmX111mmX14mm
	88-355003-0A	Cables Box	306mmX187mmX52mm
	88-355004-0A	Cleaning Cloth bag	L160xW110
	90-355002-0	woven bag	L620xW530
	90-355001-0	Cleaning Cloth	150mmx150mm
	30-49317-00	USB Description	M17
	37-00200-01	USB Disk	
	30-05000-00	Desiccant	50g 90x110, 2009/251/EC
	30-49319-00	Quick Setup Guide	157g,370X287mm
	30-49320-00	Manual Insert	
	90-010001-0	AC Cord Polybag	120x400mm
	94-267003-0	Product Barcode Label	0x30mm
	86-004030-0	Copperplate Label	40x30mm
	94-267013-0	Product Barcode Label	40x30mm
	86-004030-0	Copperplate Label	40x30mm
	94-267004-0	Serial No. Label	53x10mm
	86-005310-0	Copperplate Label	53x10mm,Pantone cool gray 6C
	30-51500-01	Guarantee Card	210X148mm
ACCESSORIES			
	17-01001-65	3.5mm female to RCA male	RPEJ-001G
	J30-83170-00		WM01500-01-G/ACM1HB,-40±2dB
	01-28100-00	HTRM2	HTRM2
	30-17251-01	Remote Control	ZR-7
	30-22100-10	Batteries	
	30-28601-11	Batteries	

M17 EXPLODED VIEWS

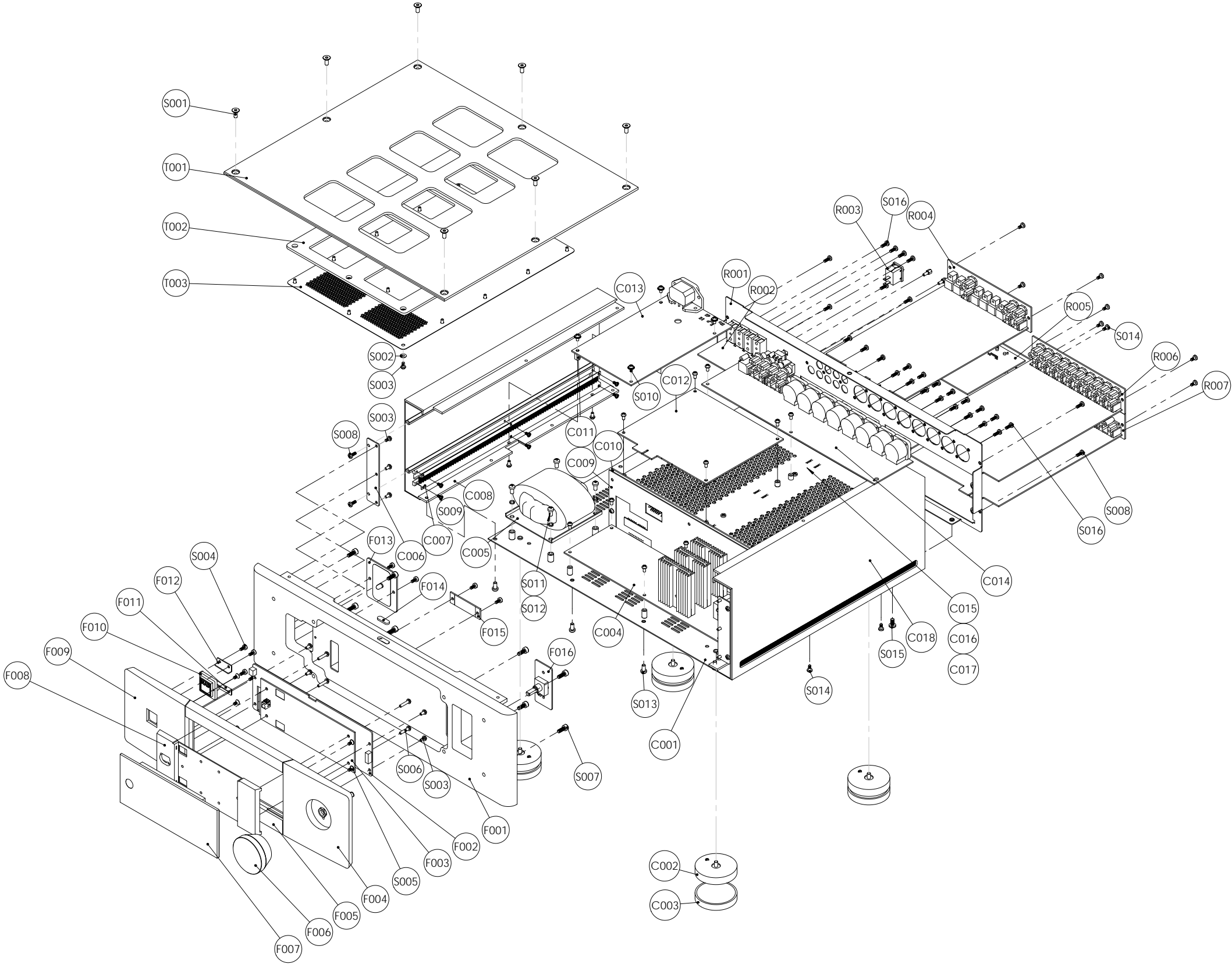

M17 EXPLODED VIEW PARTS LIST

REF.NO.	PART NO.	DESCRIPTION	Qty.	REF.NO.	PART NO.	DESCRIPTION	Qty.
C001	67-267001-1	Bottom	1	R005	01-11520-00	MV15 HDMI Assy	1
C002	J71-267002-0	Masters II Feet	4	R006	01-11521-01	Audio Analog Board	1
C003	71-267003-0	Feet Shoe Assy	4	R007	01-31704-00	Video Board	1
C004	01-31713-00	PSU Board B	1				
C005	A18-15050-00	R Type Transformer	1				
C006	67-355008-0	Fascia Connect Bracket	2	T001	70-267007-1	Main Top Cover	1
C007	67-267005-0	Vent Sheet	2	T002	70-267008-0	Second Top Cover	1
C008	70-267005-1	Left Side Panel	1	T003	67-267004-0	Perf Sheet	1
C009	67-267011-0	Connect PCB Cover	1				
C010	01-31703-00	IO Board	1				
C011	69-135001-0	Copper Spacer	2				
C012	01-31701-00	Audio 7.1 DAC Board	1	S001	J61-234510-1	Machine Screw (M4X10)	7
C013	01-31711-10	PSU Board A AH	AH:1	S002	63-010309-5	Plain Washer(Φ3xΦ9.5x0.8)	15
	01-31711-20	PSU Board A C	C:1	S003	61-023506-0	Machine Screw (MB3X6)	27
C014	01-31702-00	Audio 7.1 Interface Board	1	S004	61-023206-0	Self Taping Screw (BTB3X6)	8
C015	67-267009-0	Bracket	1	S005	61-063506-0	Machine Screw (MF3X6)	6
C016	67-267010-0	Middle Bracket	1	S006	61-023215-0	Self Taping Screw (BTB3X15)	4
C017	85-151002-0	PCB Guide	8	S007	61-224510-1	Hex Head Screw (M4X10)	8
C018	70-267006-0	Right Side Panel	1	S008	61-033208-0	Self Taping Screw (BTP3x8)	8
				S009	61-022205-6	Self Taping Screw (BTB2.6x5)	12
				S010	61-373506-0	Machine Screw(M3x6)	14
F001	70-267001-0	Rear Fascia	1	S011	61-034508-0	Machine Screw(MP4x8)	4
F002	01-31705-00	FPP Board	1	S012	63-020411-0	Spring Washer(GB93φ4)	4
F003	01-31710-00	Right Front Fascia	1	S013	61-024506-0	Machine Screw(M4x6)	10
F004	70-267003-0B	Right Front Fascia	1	S014	61-023106-2	Self Taping Screw (STB3X6)	16
F005	70-267004-0A	Center Front Fascia	1	S015	61-024106-0	Self Taping Screw (STB4X6)	4
F006	J71-267001-1	Vol. Knob Assy	1	S016	61-023208-0	Self Taping Screw (BTB3X8)	27
F007	J23-08868-00	LCD Display	1				
F008	B75-267001-0	LCD Bracket	1				
F009	70-382005-0A	Left Front Fascia	1				
F010	J71-355001-0A	NAD Logo	1				
F011	67-355011-0	Logo Clamp	1				
F012	67-355012-0	Logo Clamp Mirror	1				
F013	01-31706-00	LED Board	1				
F014	96-355001-0A	Touch Key Cap	1				
F015	01-31707-00	Touch Key Board	1				
F016	01-31708-00	Encode Board	1				
R001	67-267002-3C	Rear Panel (C)	C:1				
	67-267006-2B	Rear Panel (AH)	AH:1				
R002	01-11509-00	Trigger Board	1				
R003	A11-01101-03	Rocker Switch	1				
R004	01-31712-00	DSP Board	1				

M17 Packing Accessory Section

