

SERVICE MANUAL

S170
AV SURROUND
SOUND
PREAMPLIFIER

S170

AV SURROUND
SOUND
PREAMPLIFIER

NAD

PRODUCT SAFETY SERVICING GUIDELINES

CAUTION : DO NOT ATTEMPT TO MODIFY THIS PRODUCT IN ANY WAY. NEVER PERFORM CUSTOMIZED INSTALLATIONS WITHOUT MANUFACTURER'S APPROVAL. UNAUTHORIZED MODIFICATIONS WILL NOT ONLY VOID THE WARRANTY, BUT MAY LEAD TO YOUR BEING LIABLE FOR ANY RESULTING PROPERTY DAMAGE OR USER INJURY.

SERVICE WORK SHOULD BE PERFORMED ONLY AFTER YOU ARE THOROUGHLY FAMILIAR WITH ALL OF THE FOLLOWING SAFETY CHECKS AND SERVICING GUIDELINES. TO DO OTHERWISE, INCREASES THE RISK OF POTENTIAL HAZARDS AND INJURY TO THE USER.

WHILE SERVICING, USE AN ISOLATION TRANSFORMER FOR PROTECTION FROM AC LINE SHOCK.

SAFETY CHECKS

AFTER THE ORIGINAL SERVICE PROBLEM HAS BEEN CORRECTED. A CHECK SHOULD BE MADE OF THE FOLLOWING.

SUBJECT : FIRE & SHOCK HAZARD

1. BE SURE THAT ALL COMPONENTS ARE POSITIONED IN SUCH A WAY AS TO AVOID POSSIBILITY OF ADJACENT COMPONENT SHORTS. THIS IS ESPECIALLY IMPORTANT ON THOSE MODULES WHICH ARE TRANSPORTED TO AND FROM THE REPAIR SHOP.
2. NEVER RELEASE A REPAIR UNLESS ALL PROTECTIVE DEVICES SUCH AS INSULATORS, BARRIERS, COVERS, SHIELDS, STRAIN RELIEFS, POWER SUPPLY CORDS, AND OTHER HARDWARE HAVE BEEN REINSTALLED PER ORIGINAL DESIGN. BE SURE THAT THE SAFETY PURPOSE OF THE POLARIZED LINE PLUG HAS NOT BEEN DEFEATED.
3. SOLDERING MUST BE INSPECTED TO DISCOVER POSSIBLE COLD SOLDER JOINTS, SOLDER SPLASHES OR SHARP SOLDER POINTS. BE CERTAIN TO REMOVE ALL LOOSE FOREIGN PARTICLES.
4. CHECK FOR PHYSICAL EVIDENCE OF DAMAGE OR DETERIORATION TO PARTS AND COMPONENTS. FOR FRAYED LEADS, DAMAGED INSULATION (INCLUDING AC CORD). AND REPLACE IF NECESSARY FOLLOW ORIGINAL LAYOUT, LEAD LENGTH AND DRESS.
5. NO LEAD OR COMPONENT SHOULD TOUCH A RECEIVING TUBE OR A RESISTOR RATED AT 1 WATT OR MORE. LEAD TENSION AROUND PROTRUDING METAL SURFACES MUST BE AVOIDED.
6. ALL CRITICAL COMPONENTS SUCH AS FUSES, FLAMEPROOF RESISTORS, CAPACITORS, ETC. MUST BE REPLACED WITH EXACT FACTORY TYPES, DO NOT USE REPLACEMENT COMPONENTS OTHER THAN THOSE SPECIFIED OR MAKE UNRECOMMENDED CIRCUIT MODIFICATIONS.
7. AFTER RE-ASSEMBLY OF THE SET ALWAYS PERFORM AN AC LEAKAGE TEST ON ALL EXPOSED METALLIC PARTS OF THE CABINET, (THE CHANNEL SELECTOR KNOB, ANTENNA TERMINALS. HANDLE AND SCREWS) TO BE SURE THE SET IS SAFET TO OPERATE WITHOUT DANGER OF ELECTRICAL SHOCK. DO NOT USE A LINE ISOLATION TRANSFORMER DURING THIS TEST USE AN AC VOLTMETER, HAVING 5000 OHMS PER VOLT OR MORE SENSITIVITY, IN THE FOLLOWING MANNER; CONNECT A 1500 OHM 10 WATT RESISTOR, PARALLELED BY A .15 MFD, 150V AC TYPE CAPACITOR BETWEEN A KNOWN GOOD EARTH GROUND (WATER PIPE, CONDUIT, ETC.) AND THE EXPOSED METALLIC PARTS, ONE AT A TIME.
MEASURE THE AC VOLTAGE ACROSS THE COMBINATION OF 1500 OHM RESISTOR AND .15 MFD CAPACITOR.
REVERSE THE AC PLUG AND REPEAT AC VOLTAGE MEASUREMENTS FOR EACH EXPOSED METALLIC PART.

VOLTAGE MEASURE MUST NOT EXCEED 75 VOLTS R.M.S. THIS CORRESPONDS TO 0.5 MILLIAMPER AC ANY VALUE EXCEEDING THIS LIMIT CONSTITUTES A POTENTIAL SHOCK HAZARD AND MUST BE CORRECTED IMMEDIATELY.

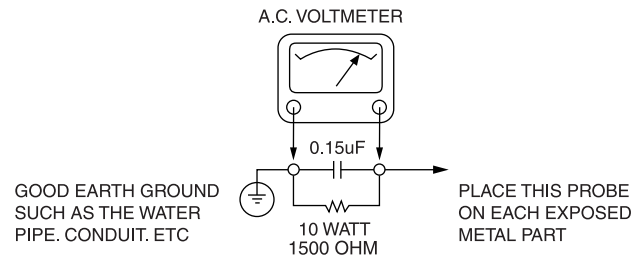

SUBJECT : GRAPHIC SYMBOLS



THE LIGHTNING FLASH WITH ARROWHEAD SYMBOL, WITHIN AN EQUILATERAL TRIANGLE, IS INTENDED TO ALERT THE USER TO THE PRESENCE OF UNINSULATED "DANGEROUS VOLTAGE" WITHIN THE PRODUCT'S ENCLOSURE THAT MAY BE OF SUFFICIENT MAGNITUDE TO CONSTITUTE A RISK OF ELECTRIC SHOCK.



THE EXCLAMATION POINT WITHIN AN EQUILATERAL TRIANGLE IS INTENDED TO ALERT THE USER TO THE PRESENCE OF IMPORTANT OPERATING AND MAINTENANCE (SERVICING) INSTRUCTIONS IN THE LITERATURE ACCOMPANYING THE APPLIANCE.

SUBJECT : TIPS ON PROPER INSTALLATION

1. NEVER INSTALL ANY PRODUCT IN A CLOSED-IN RECESS, CUBBYHOLE OR CLOSELY FITTING SHELF SPACE. OVER OR CLOSE TO HEAT DUCT, OR IN THE PATH OF HEATED AIR FLOW.
2. AVOID CONDITIONS OF HIGH HUMIDITY SUCH AS: OUTDOOR PATIO INSTALLATIONS WHERE DEW IS A FACTOR, NEAR STEAM RADIATORS WHERE STEAM LEAKAGE IS A FACTOR, ETC.
3. AVOID PLACEMENT WHERE DRAPERIES MAY OBSTRUCT REAR VENTING. THE CUSTOMER SHOULD ALSO AVOID THE USE OF DECORATIVE SCARVES OR OTHER COVERINGS WHICH MIGHT OBSTRUCT VENTILATION.
4. WALL AND SHELF MOUNTED INSTALLATIONS USING A COMMERCIAL MOUNTING KIT MUST FOLLOW THE FACTORY APPROVED MOUNTING INSTRUCTIONS A PRODUCT MOUNTED TO A SHELF OR PLATFORM MUST RETAIN ITS ORIGINAL FEET (OR THE EQUIVALENT THICKNESS IN SPACERS) TO PROVIDE ADEQUATE AIR FLOW ACROSS THE BOTTOM, BOLTS OR SCREWS USED FOR FASTENERS MUST NOT TOUCH ANY PARTS OR WIRING. PERFORM LEAKAGE TEST ON CUSTOMIZED INSTALLATIONS.
5. CAUTION CUSTOMERS AGAINST THE MOUNTING OF A PRODUCT ON SLOPING SHELF OR A TILTED POSITION, UNLESS THE PRODUCT IS PROPERLY SECURED.
6. A PRODUCT ON A ROLL-ABOUT CART SHOULD BE STABLE ON ITS MOUNTING TO THE CART. CAUTION THE CUSTOMER ON THE HAZARDS OF TRYING TO ROLL A CART WITH SMALL CASTERS ACROSS THRESHOLDS OR DEEP PILE CARPETS.
7. CAUTION CUSTOMERS AGAINST THE USE OF A CART OR STAND WHICH HAS NOT BEEN LISTED BY UNDERWRITERS LABORATORIES, INC. FOR USE WITH THEIR SPECIFIC MODEL OF TELEVISION RECEIVER OR GENERICALLY APPROVED FOR USE WITH T.V.'S OF THE SAME OR LARGER SCREEN SIZE.
8. CAUTION CUSTOMERS AGAINST THE USE OF EXTENSION CORDS, EXPLAIN THAT A FOREST OF EXTENSIONS SPROUTING FROM A SINGLE OUTLET CAN LEAD TO DISASTROUS CONSEQUENCES TO HOME AND FAMILY.

SERVICING PRECAUTIONS

CAUTION : Before servicing the A/V Receiver covered by this service data and its supplements and addends, read and follow the **SAFETY PRECAUTIONS**. **NOTE** : if unforeseen circumstances create conflict between the following servicing precautions and any of the safety precautions in this publication, always follow the safety precautions.

Remember Safety First:

General Servicing Precautions

1. Always unplug the A/V Receiver AC power cord from the AC power source before:
 - (1) Removing or reinstalling any component, circuit board, module, or any other assembly.
 - (2) Disconnecting or reconnecting any internal electrical plug or other electrical connection.
 - (3) Connecting a test substitute in parallel with an electrolytic capacitor.**Caution** : A wrong part substitution or incorrect polarity installation of electrolytic capacitors may result in an explosion hazard.
2. Do not spray chemicals on or near this A/V Receiver or any of its assemblies.
3. Unless specified otherwise in this service data, clean electrical contacts by applying an appropriate contact cleaning solution to the contacts with a pipe cleaner, cottontipped swab, or comparable soft applicator.
Unless specified otherwise in this service data, lubrication of contacts is not required.
4. Do not defeat any plug/socket B+ voltage interlocks with which instruments covered by this service manual might be equipped.
5. Do not apply AC power to this A/V Receiver and/or any of its electrical assemblies unless all solid-state device heat sinks are correctly installed.
6. Always connect test instrument ground lead to the appropriate ground before connecting the test instrument positive lead. Always remove the test instrument ground lead last.

Insulation Checking Procedure

Disconnect the attachment plug from the AC outlet and turn the power on. Connect an insulation resistance meter(500V) to the blades of the attachment plug. The insulation resistance between each blade of the attachment plug and accessible conductive parts (Note 1) should be more than 1M-ohm.

Note 1 : Accessible Conductive Parts including Metal panels, Input terminals, Earphone jacks, etc.

Electrostatically Sensitive (ES) Devices

Some semiconductor (solid state) devices can be damaged easily by static electricity. Such components commonly are called Electrostatically Sensitive (ES) Devices. Examples of typical Es devices are integrated circuits and some field effect transistors and semiconductor chip components.

The following techniques should be used to help reduce the incidence of component damage caused by static electricity.

1. Immediately before handling any semiconductor component or semiconductor-equipped assembly, drain off any electrostatic charge on your body by touching a known earth ground. Alternatively, obtain and wear a commercially available discharging wrist strap device, which should be removed for potential shock reasons prior to applying power to the unit under test.
2. After removing an electrical assembly equipped with ES devices, place the assembly on a conductive surface such as aluminum foil, to prevent electrostatic charge buildup or exposure of the assembly.
3. Use only a grounded-tip soldering iron to solder or unsolder ES devices.
4. Use only an antistatic solder removal device. Some solder removal devices not classified a "anti-static" can generate electrical charges sufficient to damage ES devices.
5. Do not use freonpropelled chemicals. These can generate electrical charge sufficient to damage ES devices.
6. Do not remove a replacement ES device from its protective package until immediately before you are ready to install it. (Most replacement ES devices are packaged with leads electrically shorted together by conductive foam, aluminum foil, or comparable conductive material).
7. Immediately before removing the protective material from the leads of a replacement ES device, touch the protective material to the chassis or circuit assembly into which the device will be installed.

Caution : Be sure no power is applied to the chassis or circuit, and observe all other safety precautions.

8. Minimize bodily motions when handing unpackaged replacement ES devices. (Normally harmless motion such as the brushing together of your clothes fabric or the lifting of your foot from a carpeted floor can generate static electricity sufficient to damage an ES device.)

CONTENTS

FRONT PANEL / REAR PANEL VIEW	3
WIRING DIAGRAM	4
SPECIFICATIONS	5
BLOCK DIAGRAM	6
PCB LAYOUT	7-10
SCHEMATIC DIAGRAM	11-25
ELECTRICAL PARTS LIST	26-35
EXPLODED VIEW	36
EXPLODED VIEW PARTS LIST	xx
PACKING DIAGRAM	38
NOTES	39

SERVICE SAFETY PRECAUTIONS

1. Replacing the Fuses

CAUTION: FOR CONTINUED PROTECTION AGAINST THE RISK OF FIRE REPLACE ONLY WITH SAME TYPE OF FUSE.

REFERENCE NO.	PART NUMBER	DESCRIPTION
FUSE1*C \triangle	5120-0050-0	1.6A 250V Time Lag
FUSE2*C \triangle	5100-1020-1B	1A 250V Time Lag
FUSE3*C \triangle	5120-0065-0	2A 250V Time Lag

NOTE:

*C : European version only

2. Safety-check out

Before returning the product to the customer, make leakage current or resistance measurements to determine that exposed parts are acceptably insulated from the supply circuit.

Parts marked with the symbol \triangle are critical with regard to the risk of fire and electric shock. Replace only with parts recommended by the manufacturer.

FRONT PANEL CONTROLS

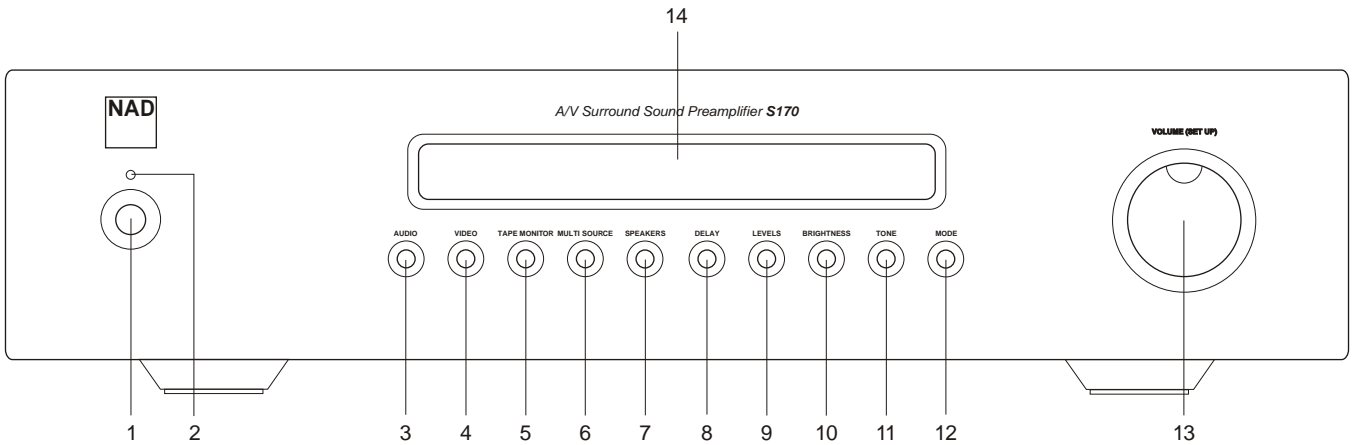

- | | | |
|-------------------------|-----------------|--------------------------|
| 1. POWER SWITCH | 6. MULTI SOURCE | 11. TONE |
| 2. POWER INDICATOR | 7. SPEAKERS | 12. MODE |
| 3. AUDIO INPUT SELECTOR | 8. DELAY | 13. VOLUME/SETUP CONTROL |
| 4. VIDEO INPUT SELECTOR | 9. LEVELS | 14. DISPLAY |
| 5. TAPE MONITOR | 10. BRIGHTNESS | |

The graphic symbol of a lightning flash with an arrow point within a triangle signifies that there is dangerous voltage within the unit and it poses a hazard to anyone removing the cover to gain access to the interior of the unit. **Only qualified service personnel should make such attempt.**

The graphic symbol of an exclamation point within an equilateral triangle warns a user of the device that it is necessary to refer to the instruction manual and its warnings for proper operation of the unit.

REAR PANEL CONNECTIONS

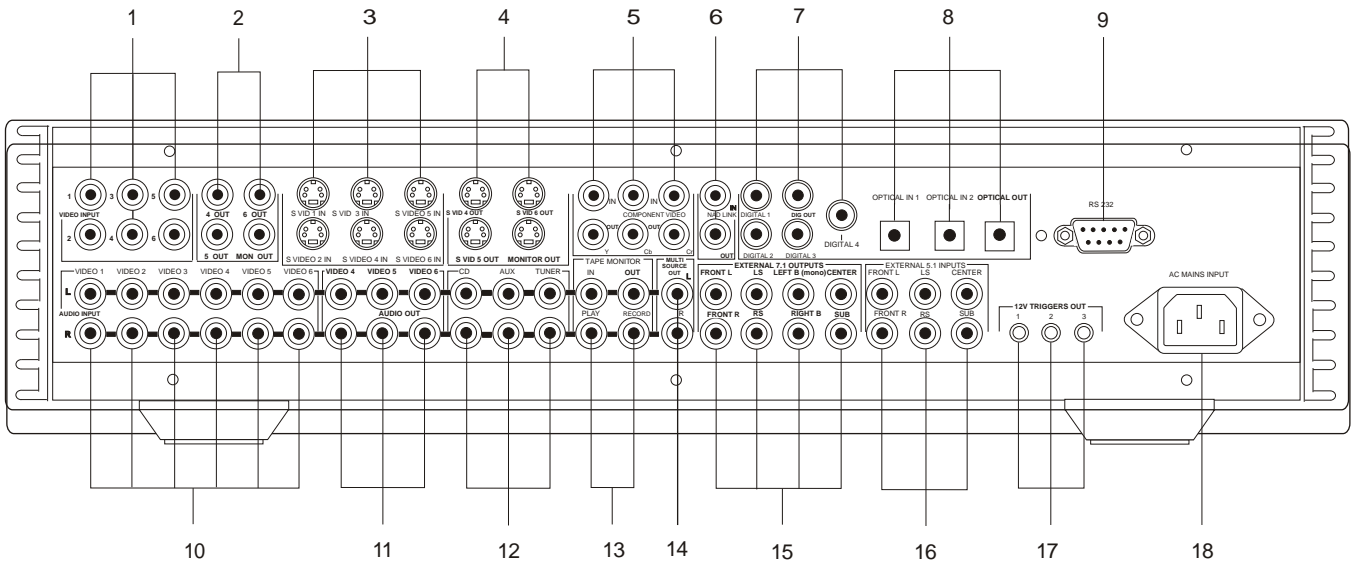

- | | | |
|-----------------------------------|----------------------------------|-------------------------|
| 1. VIDEO INPUTS | 7. COAXIAL DIGITAL INPUTS/OUTPUT | 13. TAPE INPUT/OUTPUT |
| 2. VIDEO OUTPUTS | 8. OPTICAL DIGITAL INPUTS/OUTPUT | 14. MULTI SOURCE OUTPUT |
| 3. S-VIDEO INPUTS | 9. RS-232 | 15. EXT. 7.1 OUTPUTS |
| 4. S-VIDEO OUTPUTS | 10. AUDIO INPUTS | 16. EXT. 5.1 INPUTS |
| 5. COMPONENT VIDEO INPUTS/OUTPUTS | 11. AUDIO OUTPUTS | 17. 12V TRIGGER OUTPUTS |
| 6. NAD LINK INPUT/OUTPUT | 12. CD/AUX/TUNER INPUTS | 18. AC INLET |

WIRING DIAGRAM

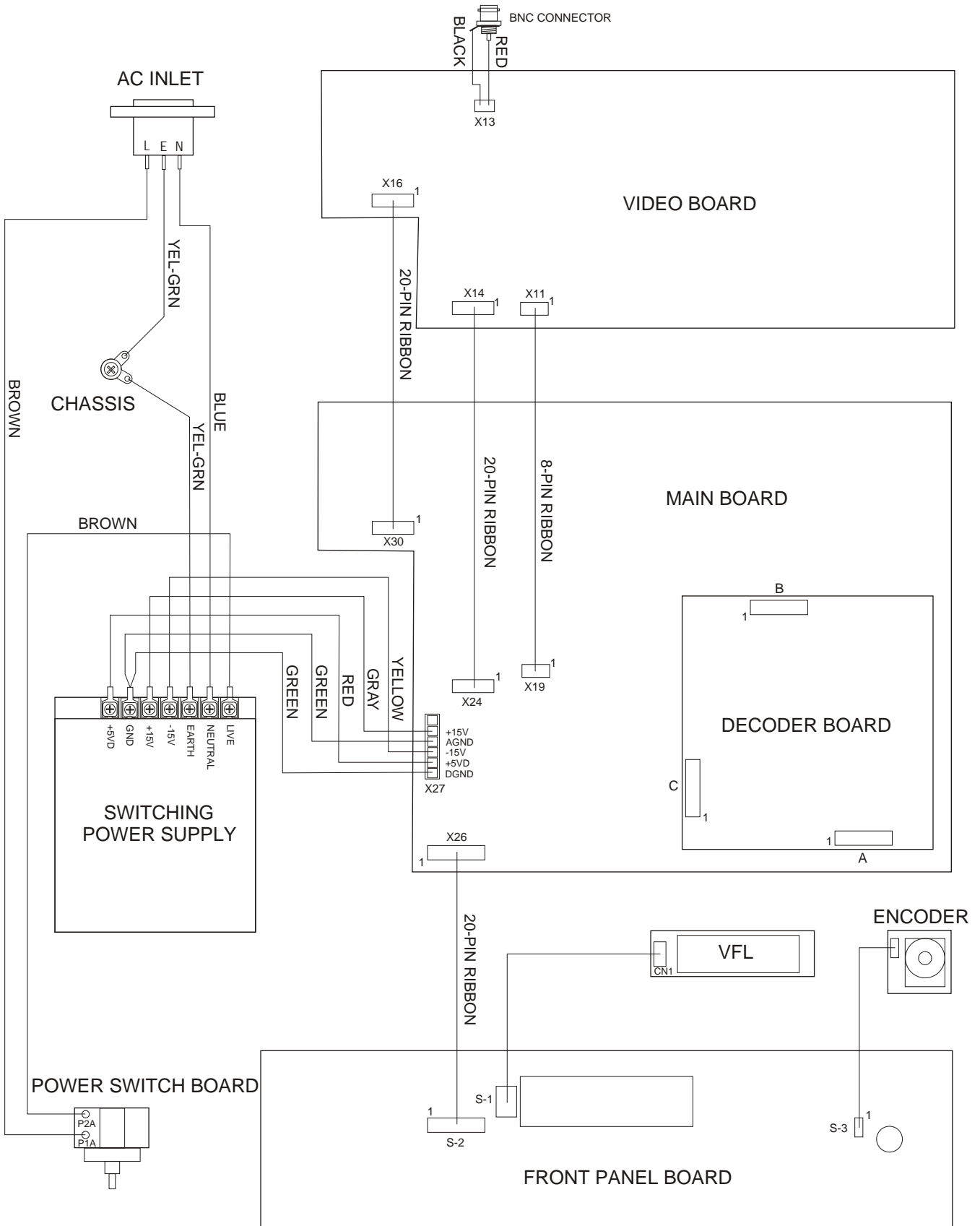

SPECIFICATIONS

STANDARD SETTINGS

1. Volume = 0dB
2. Tone Controls = 0dB
3. LFE Channel = 0dB
4. Bass Limiter = Off
5. Channel Levels = 0dB
6. Delays = 0 meters/ft
7. Speakers = Large
8. Subwoofer = Yes

SURROUND BACK LEFT & RIGHT

1. Dolby 1.0 test disc (5.1 input)
2. Choose titles with SL and SR signals
3. Put unit to 6.1 mode setting

DOLBY DIGITAL MODE: Dolby test disc 1.0

1. Output level	All 7	Title 30	997Hz	0.22 ± 0.03 V
2. Channel Difference	All 5	Title 30	997Hz	0 ± 0.5 dB
3. Frequency Response	L	Title 43	200Hz-20kHz	0 ± 0.2 dB
Title 30 for reference. For Sub,	R	Title 45	200Hz-20kHz	0 ± 0.2 dB
reference is start of title 48	C	Title 44	200Hz-20kHz	0 ± 0.2 dB
	SL	Title 46	200Hz-20kHz	0 ± 0.2 dB
	SR	Title 47	200Hz-20kHz	0 ± 0.2 dB
	Sub	Title 48	20Hz-80Hz	0 ± 0.2 dB
4. THD	L	Title 65	997Hz	≤0.01%
With audio BPF	R	Title 67	997Hz	≤0.01%
	C	Title 66	997Hz	≤0.01%
	SL	Title 68	997Hz	≤0.01%
	SR	Title 69	997Hz	≤0.01%
	Sub	Title 70	30Hz	≤0.03%
5. S/N Ratio, A-wtd	All 5	Title 63		≥65dB
20kHz LPF				
6. Channel Separation	All 5	Title 65-69	997Hz	≥65dB
20kHz LPF				

DTS MODE: DTS Consumer Product Evaluation Test Disc

1. Output level	All 5	Track 21	1kHz	0.22 ± 0.03 V
For Sub, ref. L out at track 10	Sub	Track 15	30Hz	+9.4 ± 1 dB
2. Channel Difference	All 5	Track 21	1kHz	0 ± 0.5 dB
3. Frequency Response	L	Track 26	20Hz-20kHz	0 ± 0.2 dB
Track 21 for reference	R	Track 27	20Hz-20kHz	0 ± 0.2 dB
	C	Track 30	20Hz-20kHz	0 ± 0.5 dB
	SL	Track 28	20Hz-20kHz	0 ± 0.5 dB
	SR	Track 29	20Hz-20kHz	0 ± 0.5 dB
4. THD	L	Track 10	1kHz	≤0.01%

With audio BPF	R	Track 11	1kHz	≤0.01%
	C	Track 14	1kHz	≤0.01%
	SL	Track 12	1kHz	≤0.01%
	SR	Track 13	1kHz	≤0.01%

DOLBY PROLOGIC MODE: Analog input signal = 2V

1. THD With 80kHz LPF	L	L	1kHz	≤0.05%
	R	R	1kHz	≤0.05%
	C	L = R	1kHz	≤0.05%
	SL	L = -R	1kHz	≤0.05%
	SR	L = -R	1kHz	≤0.05%

2. S/N Ratio wtd	A- L	L	1kHz	≥85dB
	R	R	1kHz	≥85dB
	C	L = R	1kHz	≥85dB
	SL	L = -R	1kHz	≥85dB
	SR	L = -R	1kHz	≥85dB

3. Frequency Response 1kHz reference	L	L	40Hz	0 ± 0.2 dB
			20kHz	0 ± 0.4 dB
	R	R	40Hz	0 ± 0.2 dB
			20kHz	0 ± 0.4 dB
	C	L = R	300Hz	0 ± 0.2 dB
			20kHz	0 ± 0.4 dB
	SL/SR	L = -R	30Hz	0 ± 0.4 dB
6.5kHz			-3 ± 1 dB	

POWER AMPLIFIER: External 5.1 input = 2V

1. Output level	All 5	1kHz	2.2 ± 0.3 V
2. THD, with 30kHz LPF	All 5	1kHz	≤0.01%
3. S/N Ratio, A-wtd	All 5		≥90dB
4. Frequency response	All 5	20Hz-20kHz	0 ± 0.2 dB

PHYSICAL SPECIFICATIONS:

Size (W x H x D) 17 3/4 x 3 7/8 x 11 1/4"
(450 x 97 x 285 mm)
Net weight 11 lbs (4.99kg)
Shipping weight 13 lbs (5.89kg)

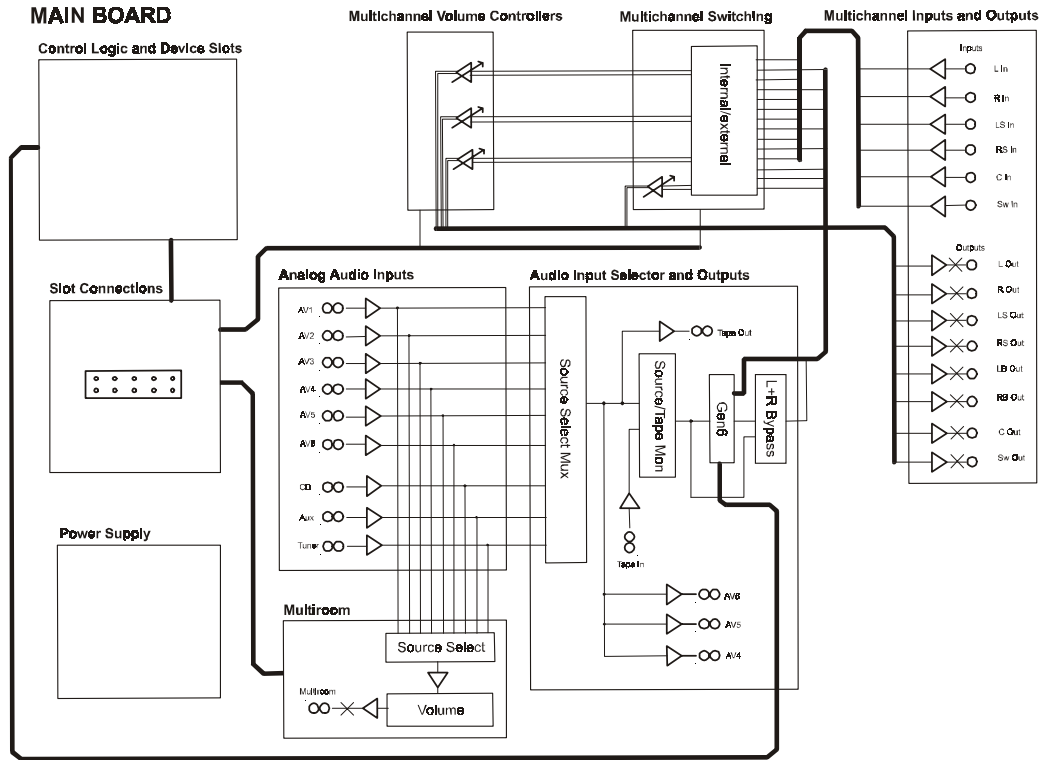

BLOCK DIAGRAM

VIDEO BOARD

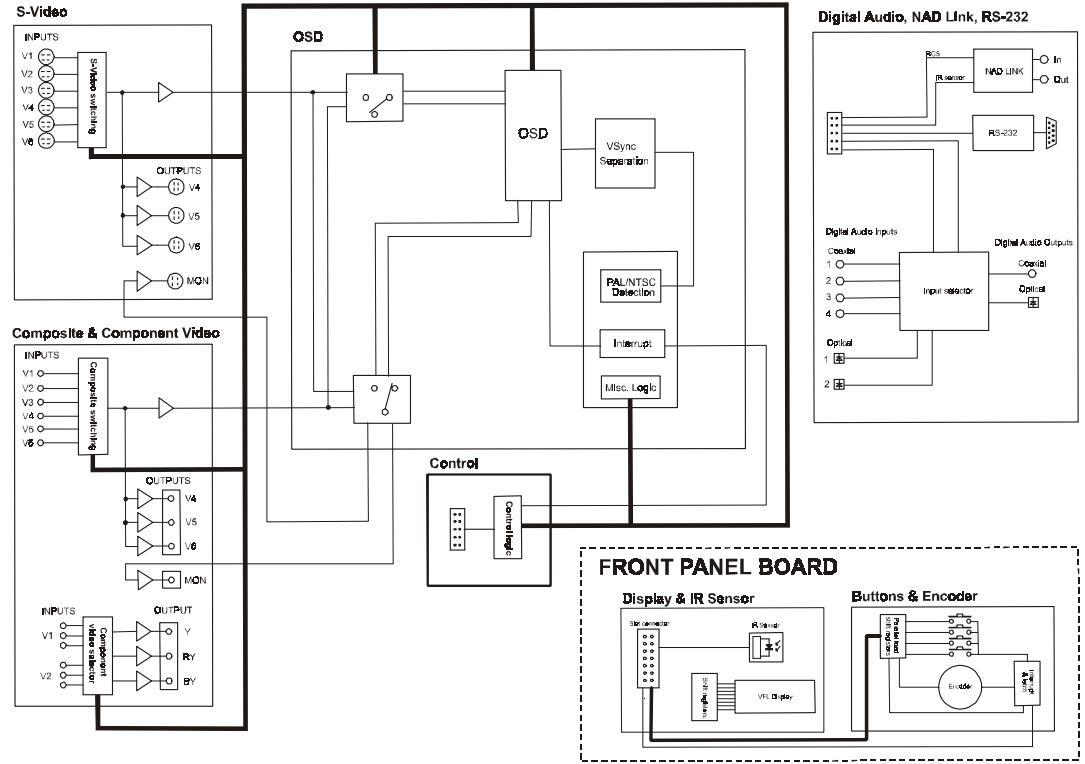

Video & Digital I/O schematics

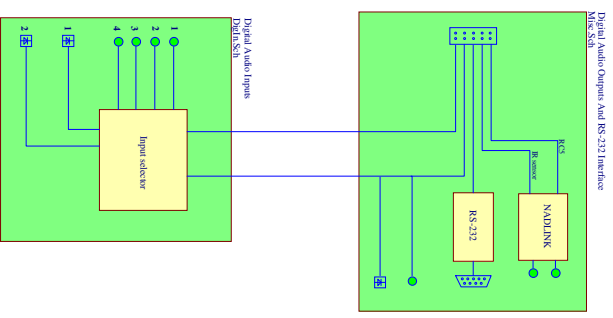
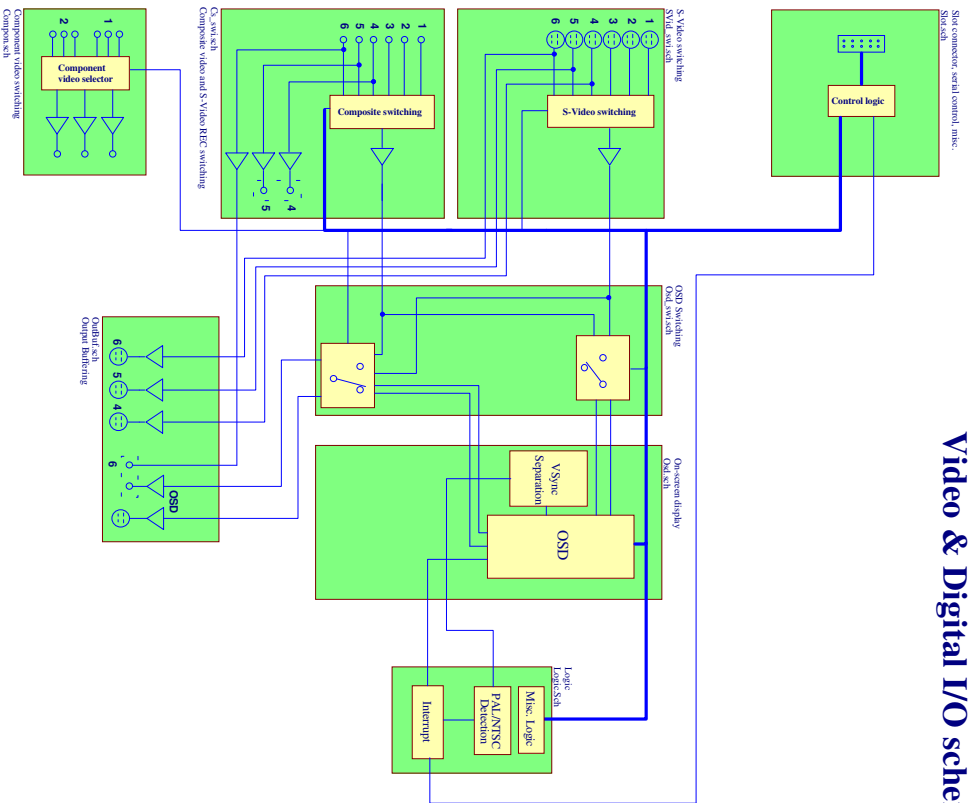

Title <i>Main sheet</i>	
Author: Ismail Mylymaki	Elektroninen Design Finland
Project: NAD S170	Yrityksenkatu 2 FINLAND
Revision: 2.2b	Tel: +358 205 345 700
Date: 17-Mar-2002	Time: 13:16:11
Sheet: A3	Sheet: of 11
File:	

KEY BOARD - COMPONENT SIDE

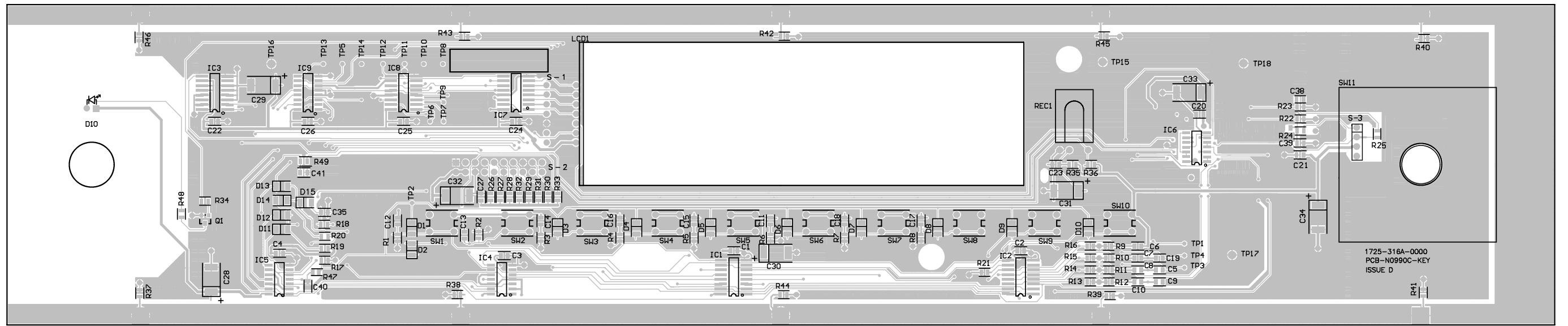

KEY BOARD - SOLDER SIDE

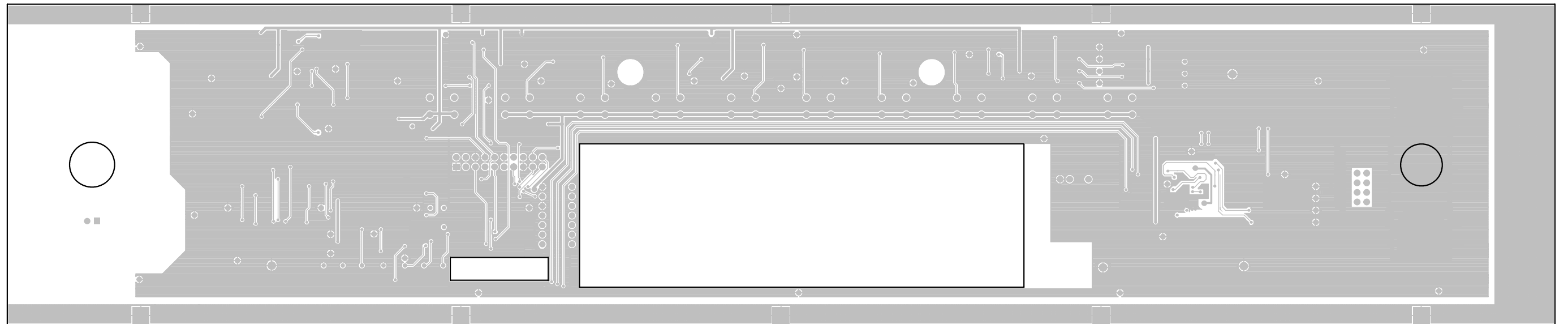

VIDEO BOARD - COMPONENT SIDE

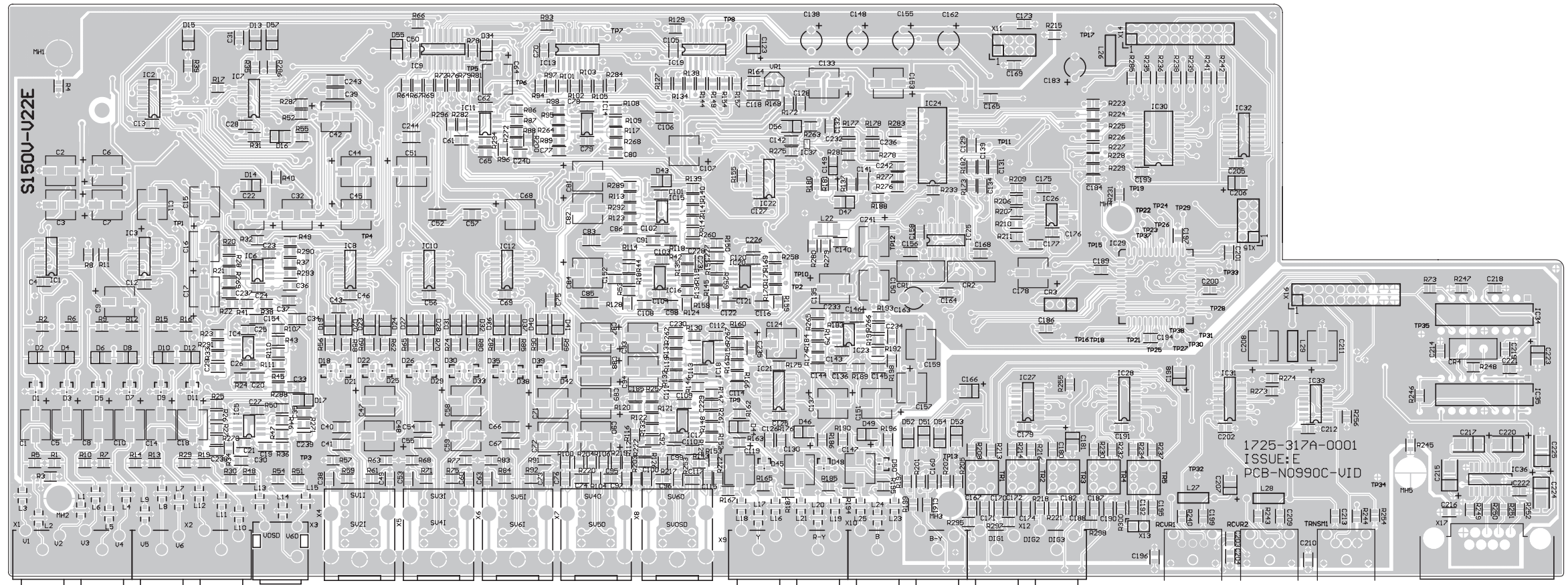

VIDEO BOARD - SOLDER SIDE

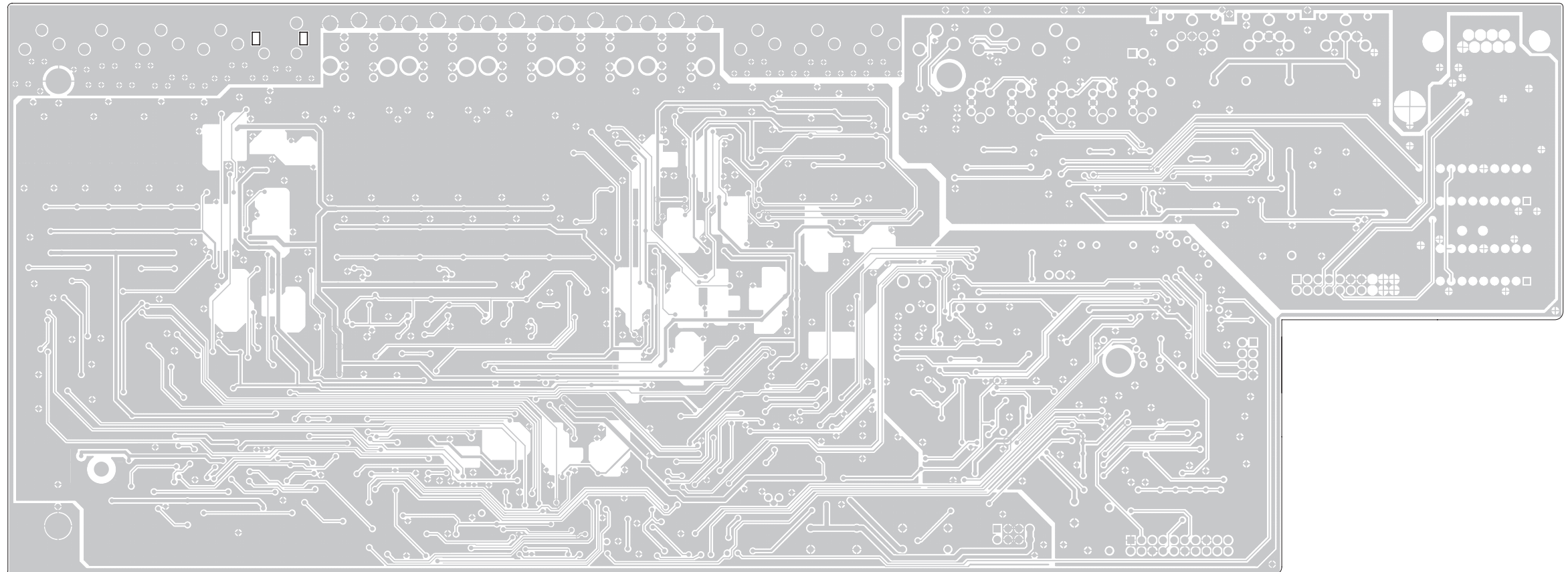

PCB LAYOUT
MAIN BOARD - COMPONENT SIDE

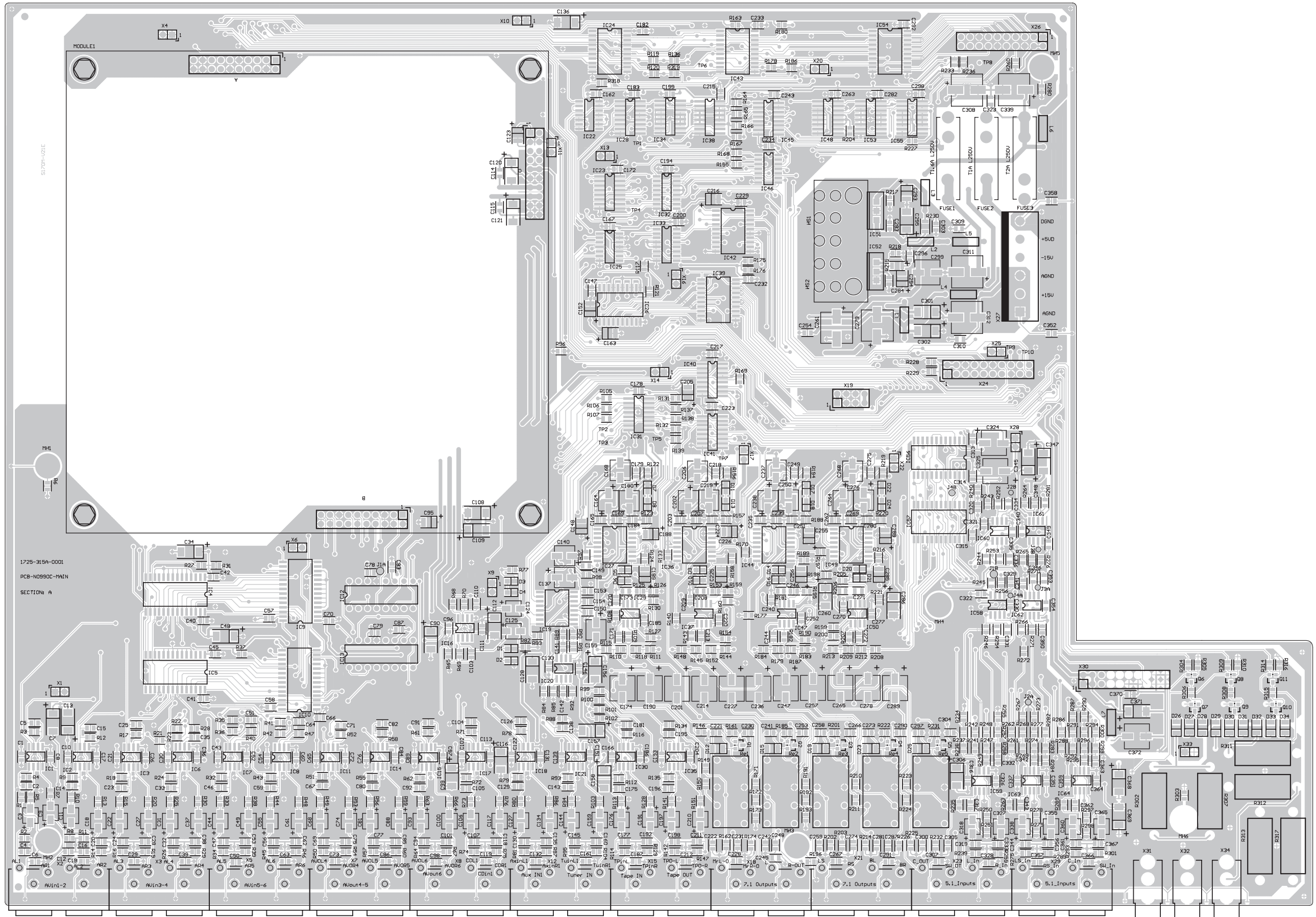

MAIN BOARD - SOLDER SIDE

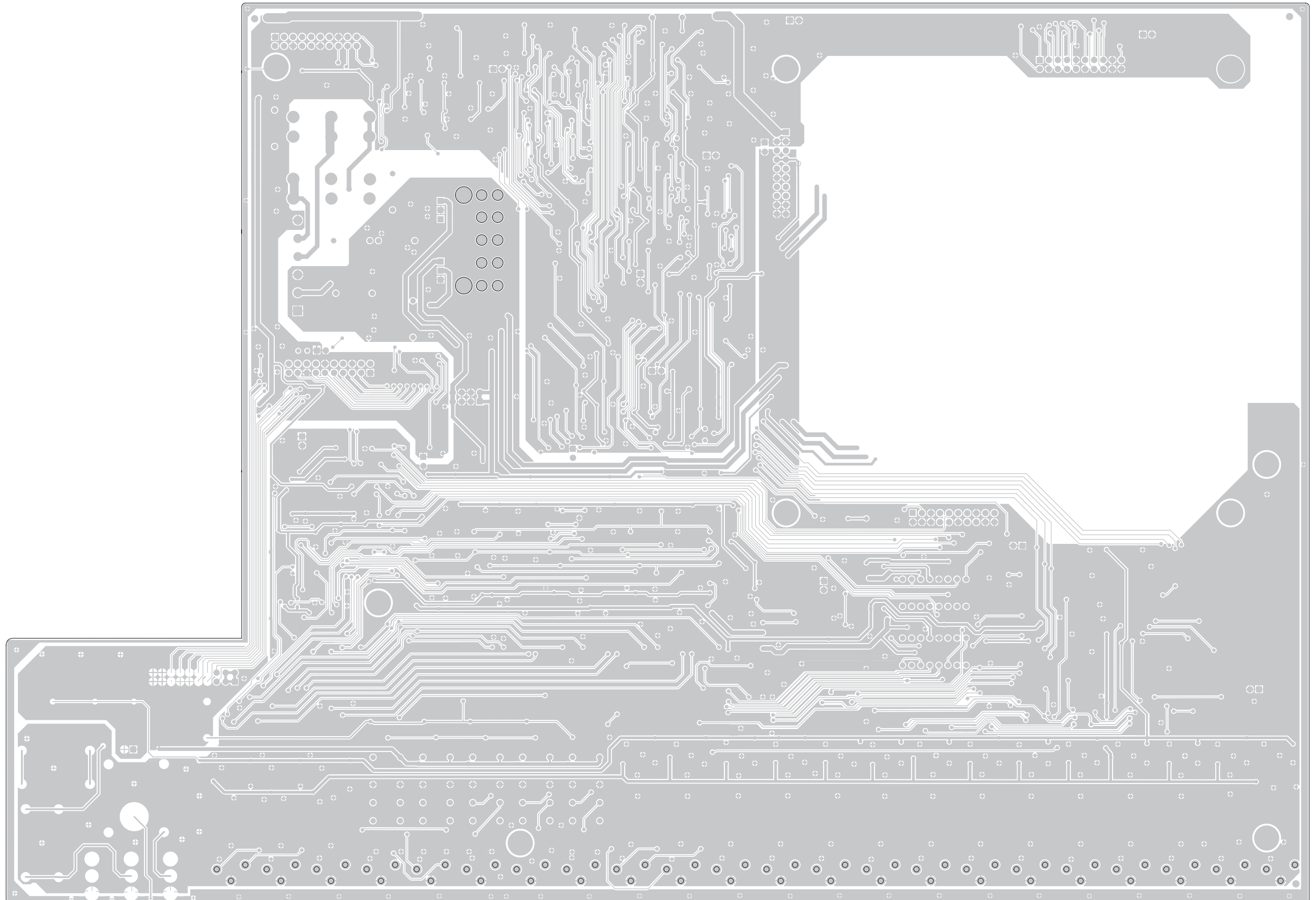

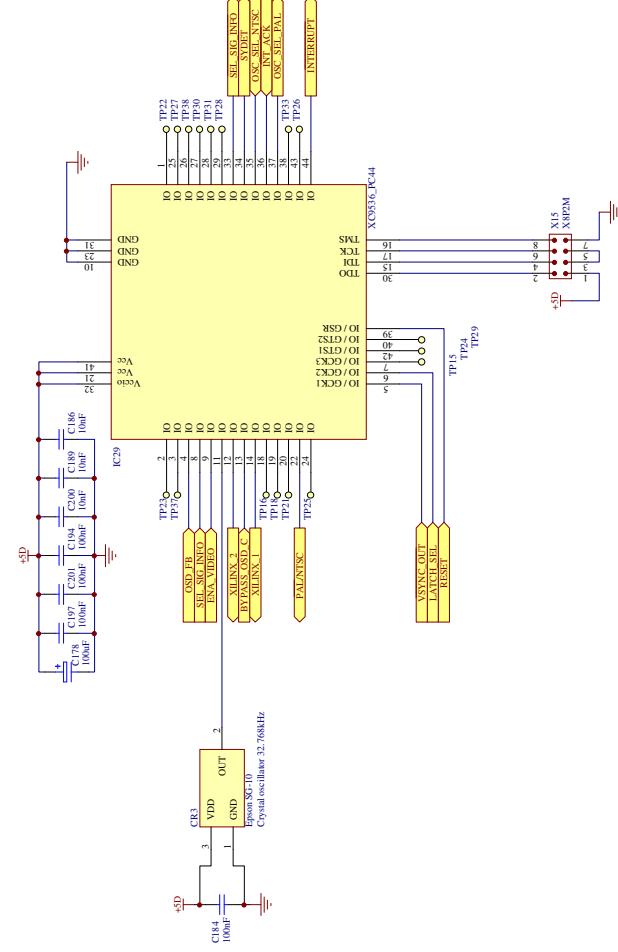

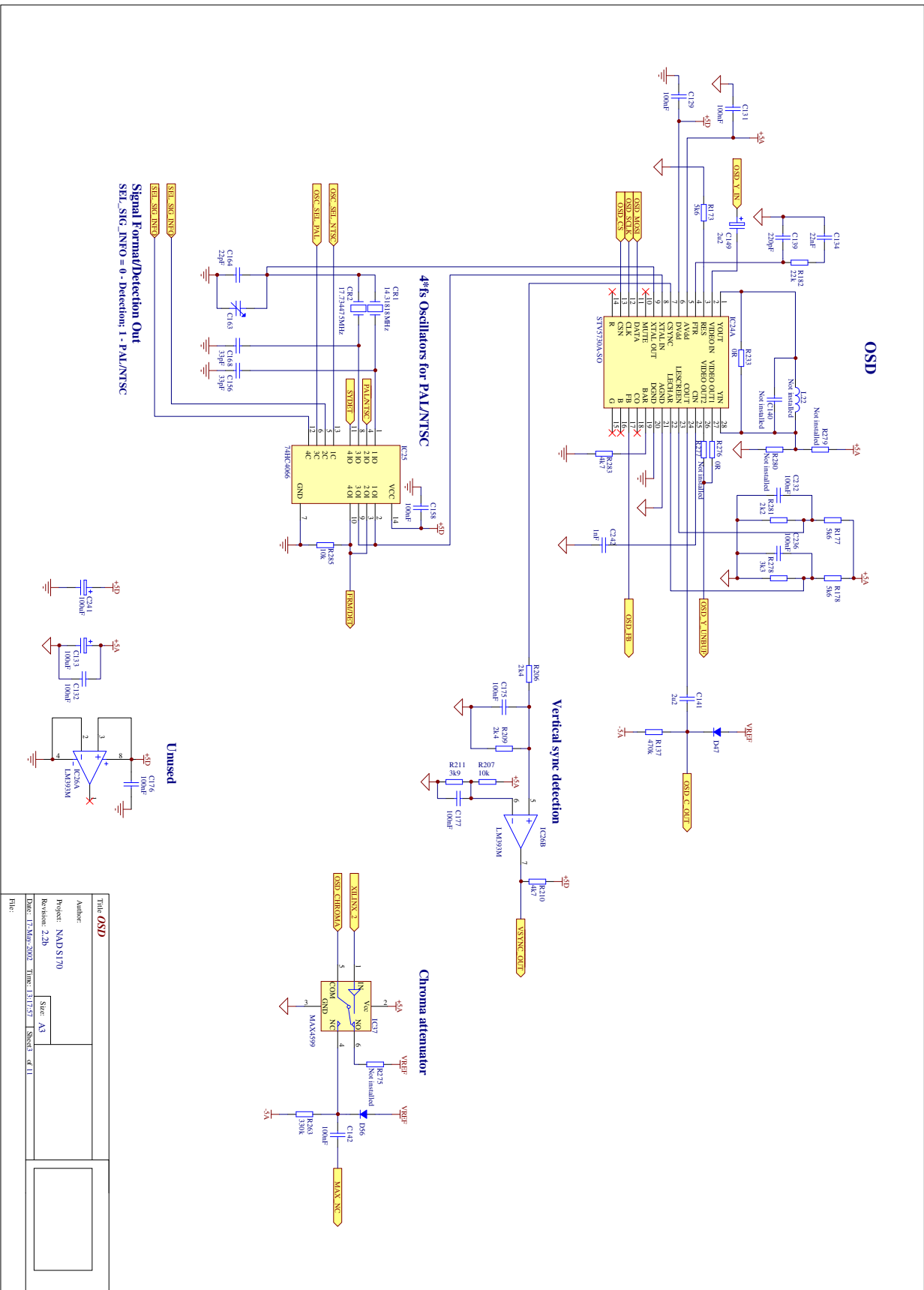

SVideo OSD output buffers

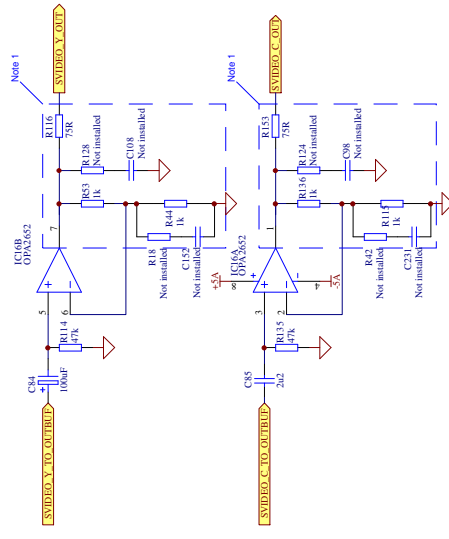

SVideo 4 output buffers

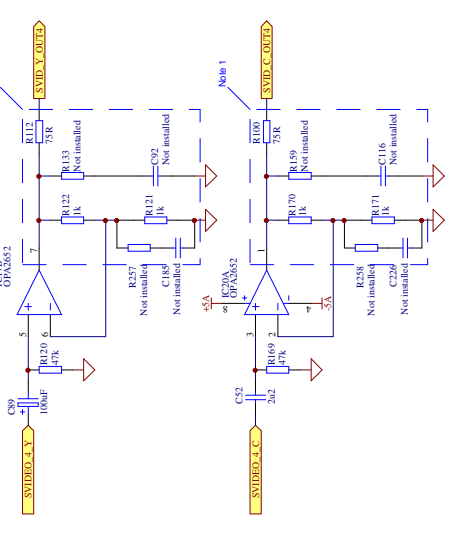

SVideo 5 & 6 output buffers

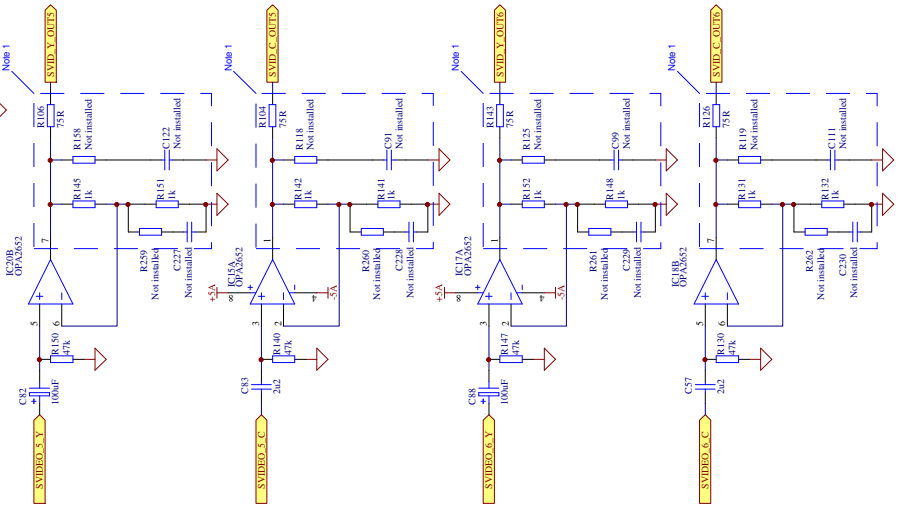

Composite video OSD output buffer

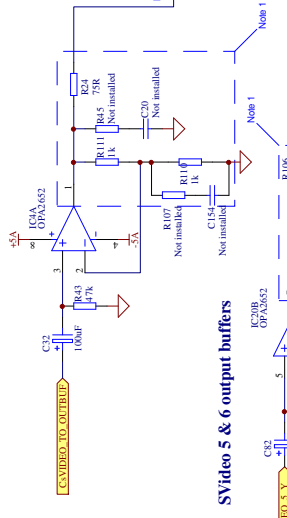

Composite video 6 and OSD outputs

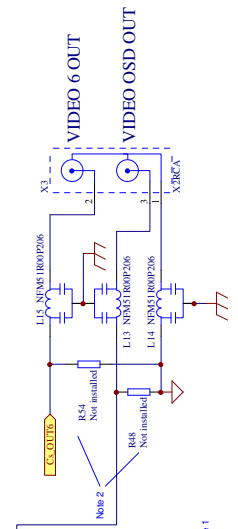

S-Video outputs

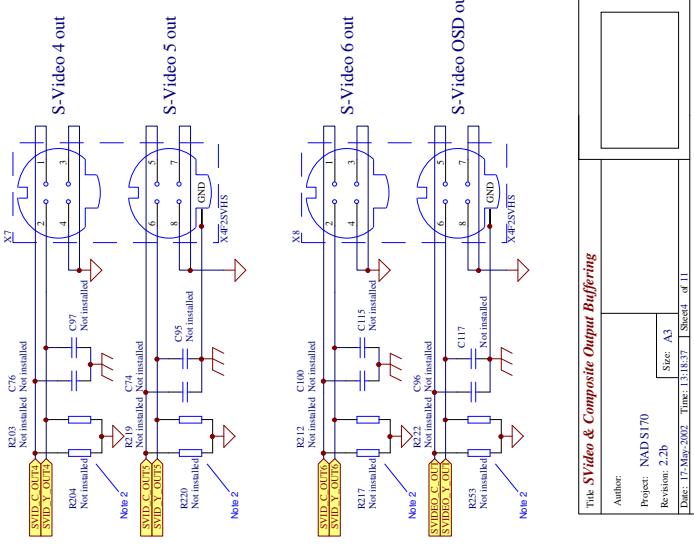

Title SVideo & Composite Output Buffering

Author:			
Project:	NAD S170		
Revision:	2.2.2b		
Date:	17-Mar-2002	Time:	13:18:37
Sheet:	4 of 11	Size:	A3

File:

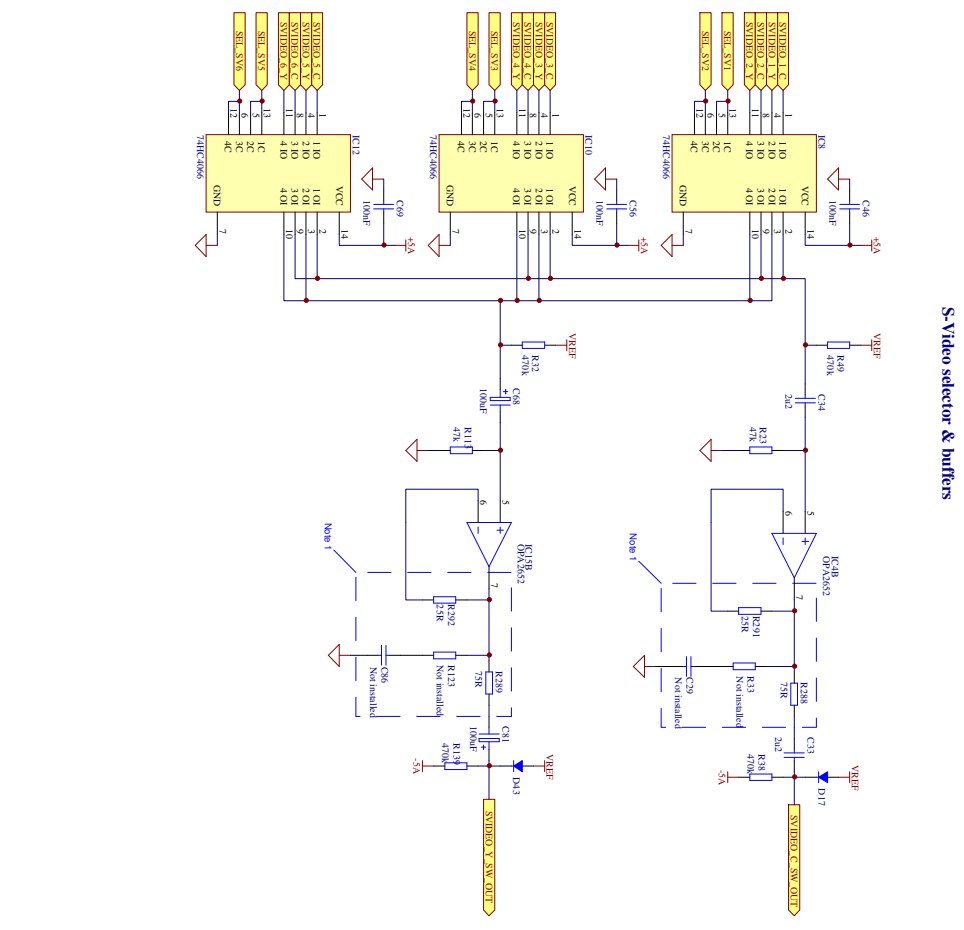
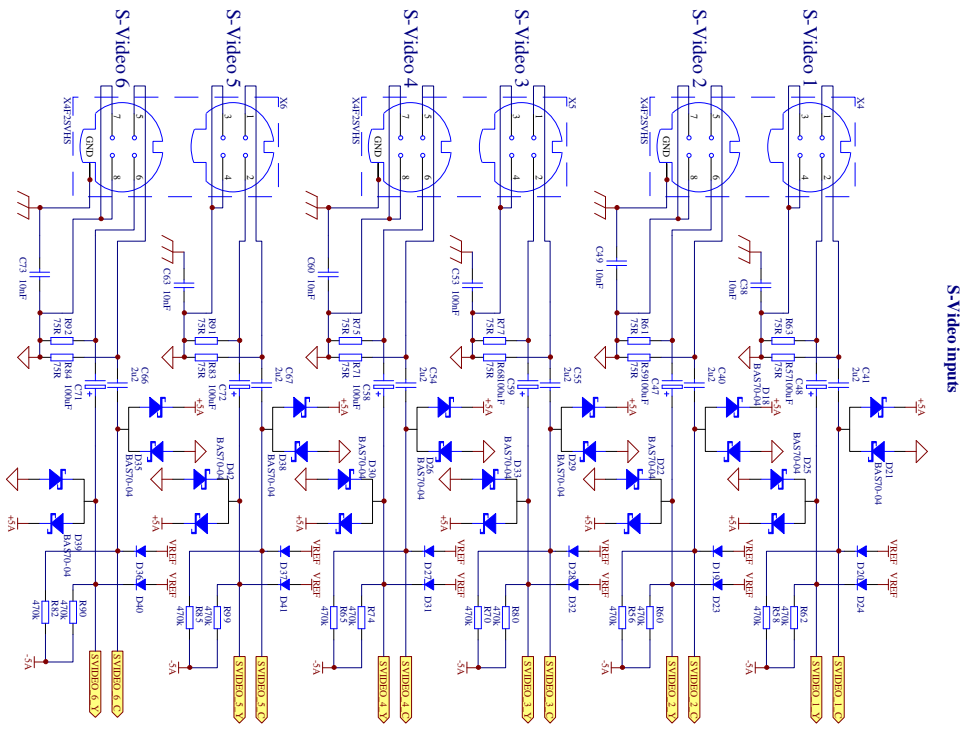

Title: S-Video switching	
Author:	
Project: NADS170	
Revision: 2.2b	
Date: 17-Mar-2002	Time: 13:19:11
Sheet: A3	Sheet: of 11
File:	

Component video selector & buffers

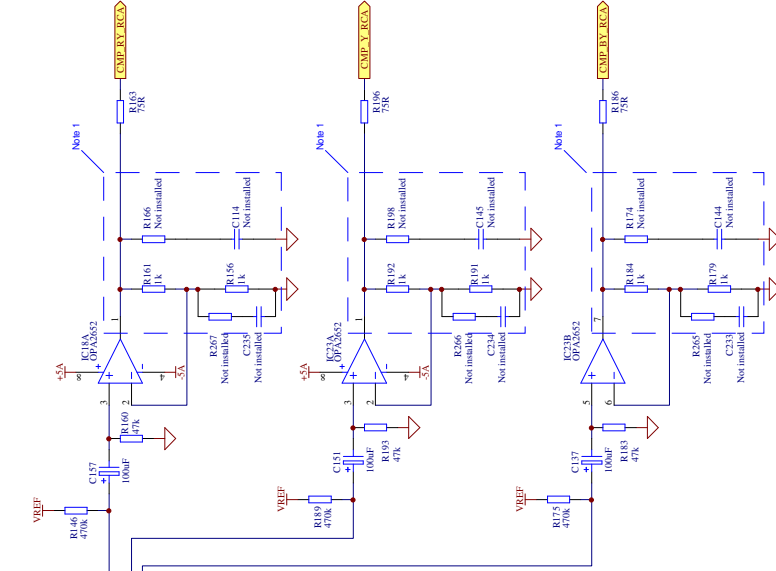

Component video inputs & outputs

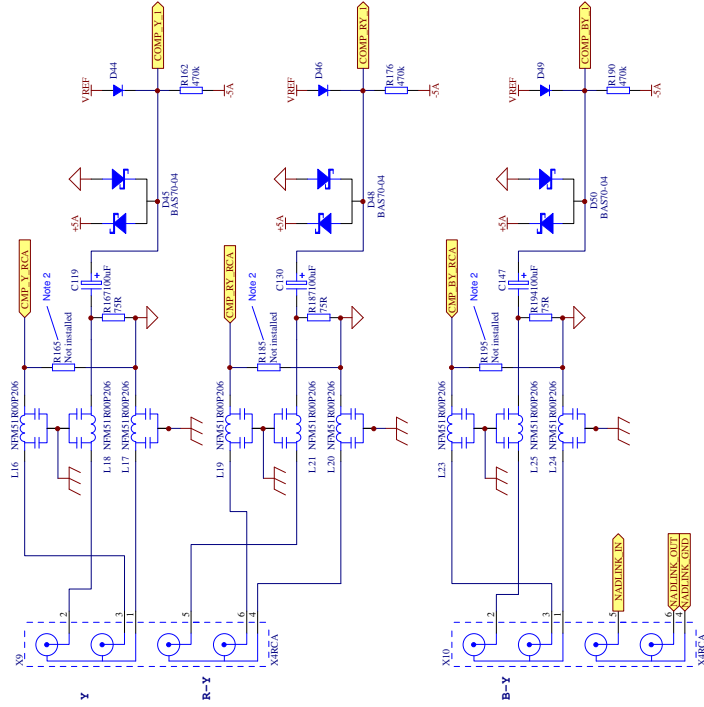

Title Component video switching

Author:

Project: NAD5170

Revision: 2.2.b

Size: A3

Date: 17-Mar-2002 Time: 13:20:07 Sheet: of 11

File:

Slot connector & Control bus buffering

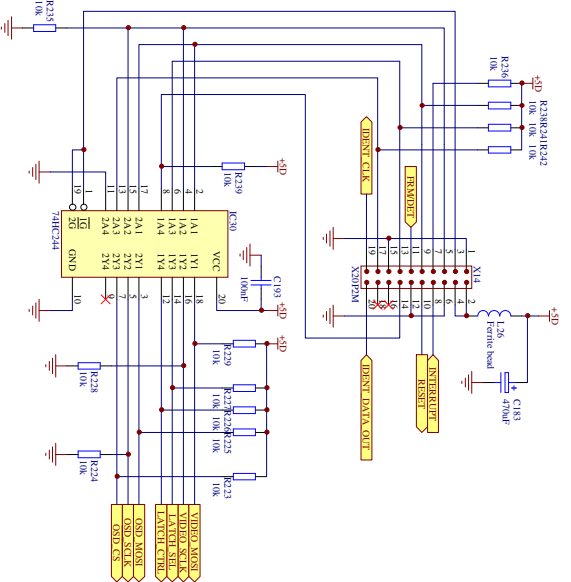

Notes

- Note 1: No PCB groundplane inside this component area
- Note 2: Should be at least 100k if installed

3.4 V reference voltage

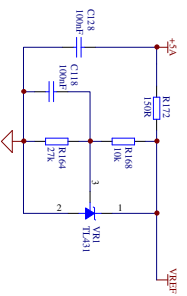

Slot Identification circuit

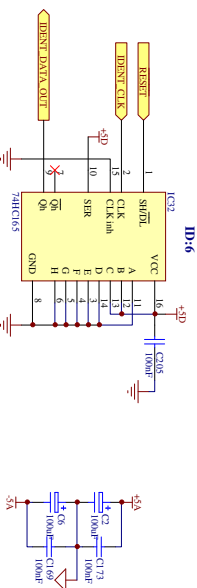

Mounting holes

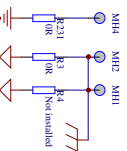

Video power connector

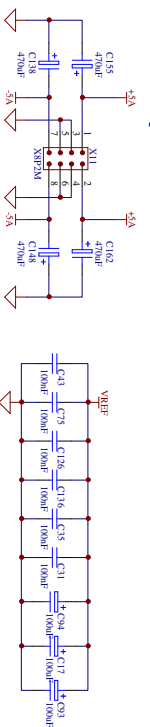

VGND & DGND Testpoints

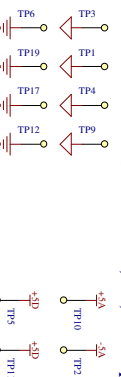

+5D,+5A,-5A Testpoints

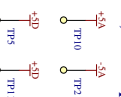

Source selector, REC selector & OSD control signals

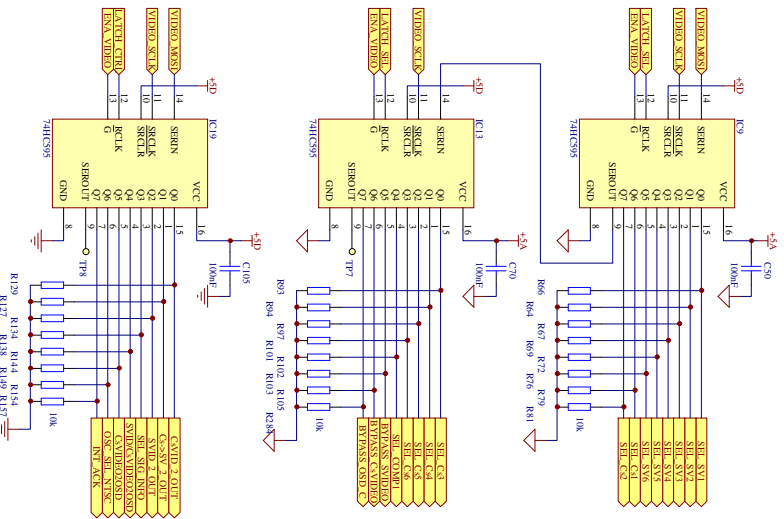

Miscellaneous circuits

Title	Miscellaneous circuits		
Author			
Project	NADS170		
Revision	2.2b		
Date	17-Mar-2002	Time	13:30:53
Sheet	4/11	Sec	A3
File			

Composite video inputs

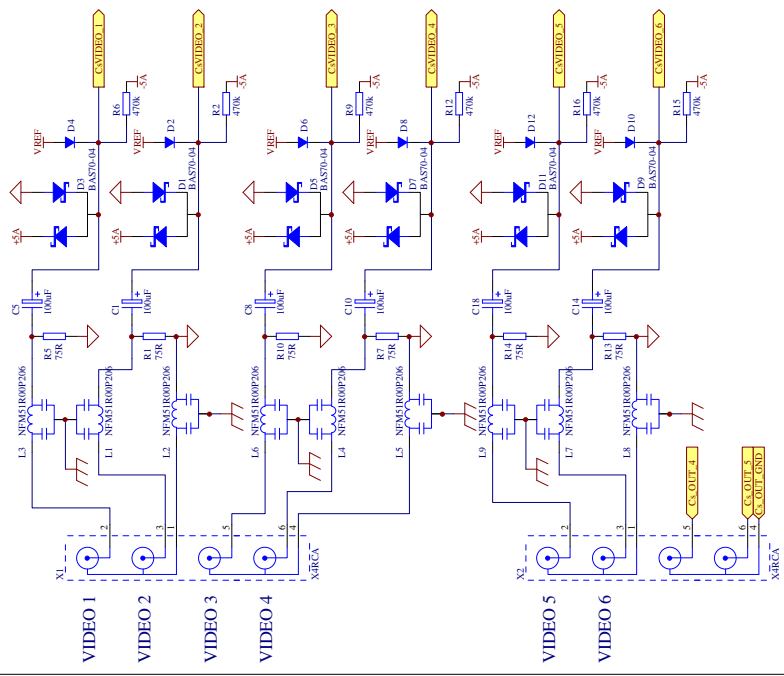

Composite video selectors & buffers

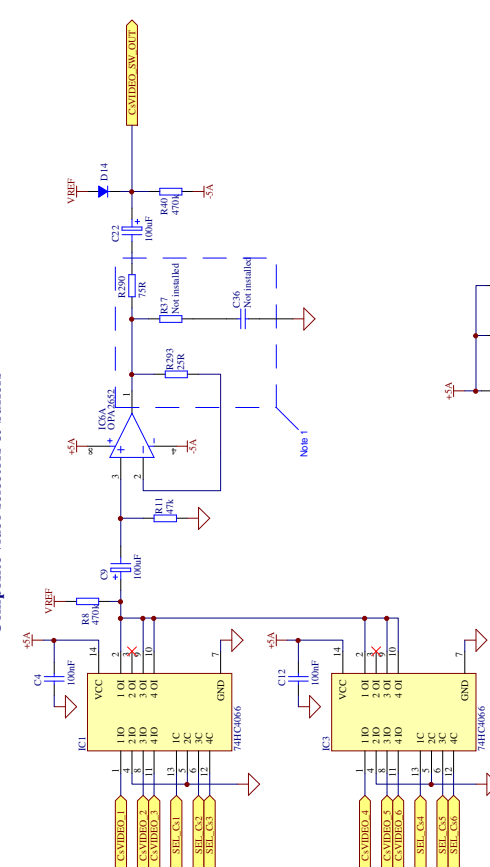

Composite Out Buffering

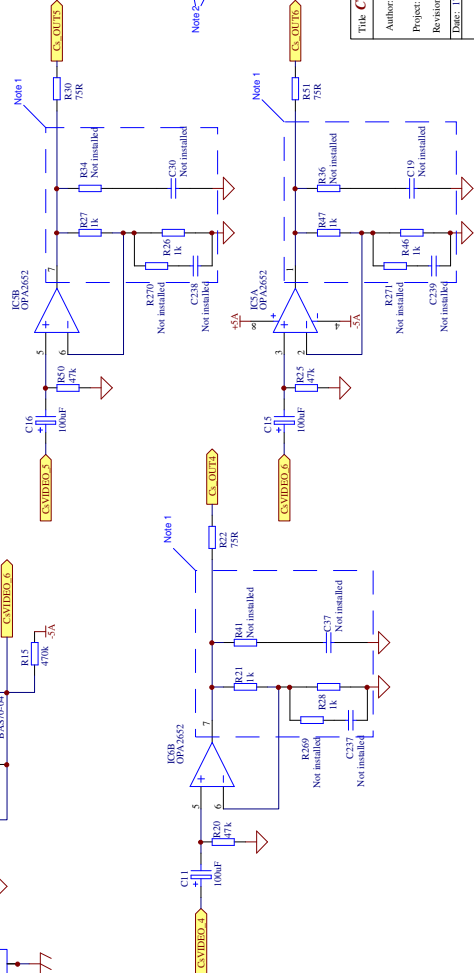

Composite video 4 & 5 outputs

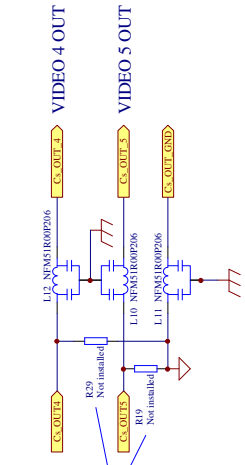

Title Composite video switching

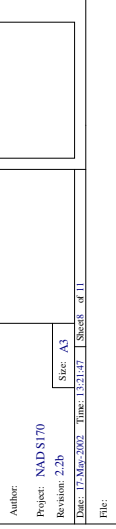

Author:
 Project: NAD5170
 Revision: 2.2b
 Date: 17-Mar-2002 Time: 13:21:47 Sheet: 4 of 11
 Size: A3

OSD Output Buffering And Switching

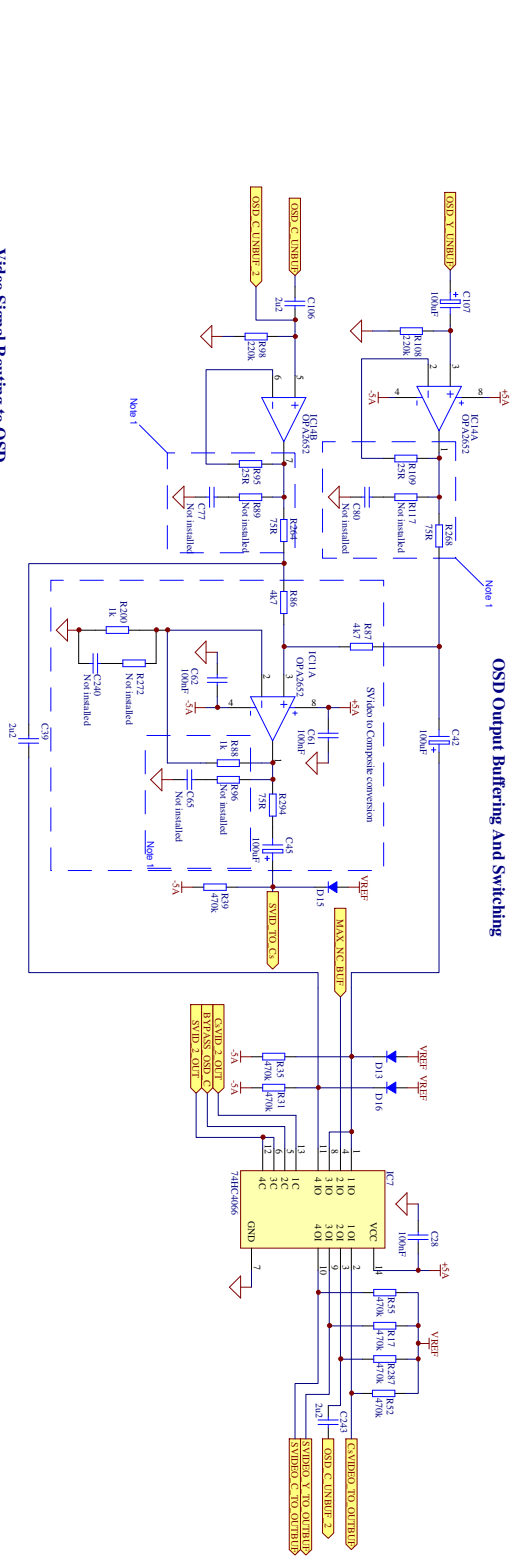

OSD bypass

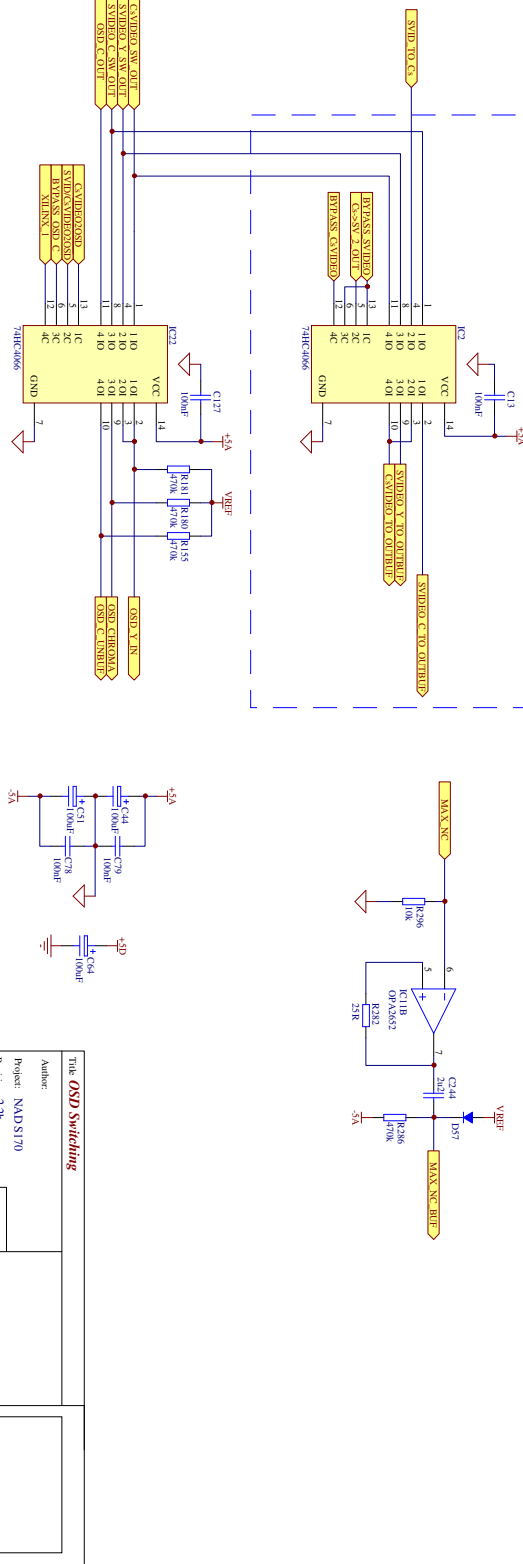

Title OSD Switching	
Author:	
Project: NADS170	
Revision: 2.2b	
Date: 17-Mar-2002	Time: 13:23:33
Sheet: 4/11	

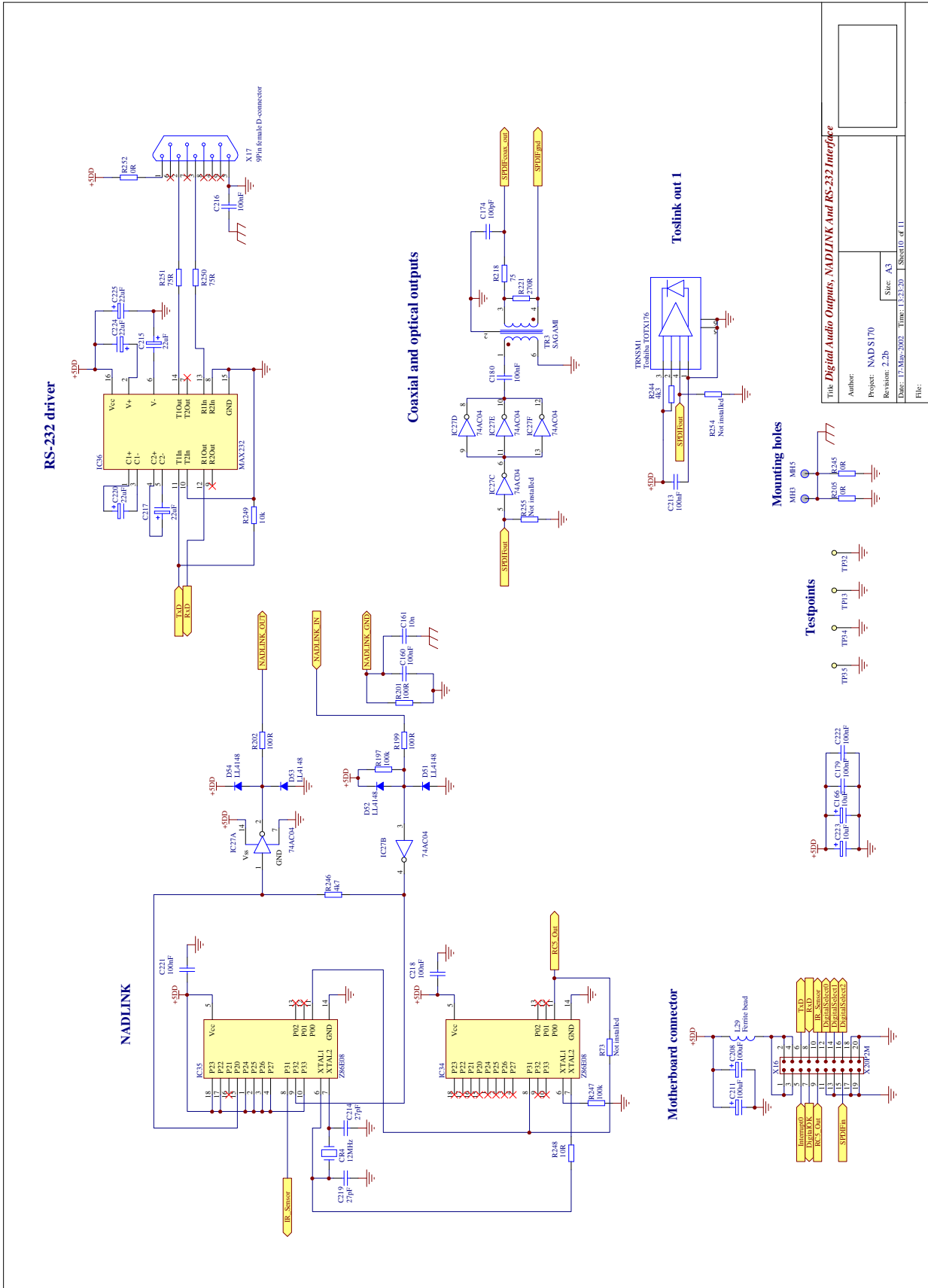

Title: **Digital Audio Outputs, NADLINK And RS-232 Interface**
 Author:
 Project: NAD S170
 Revision: 2.2b
 Date: 17-Mar-2002 Time: 13:33:30 Sheet 0 of 11
 File:

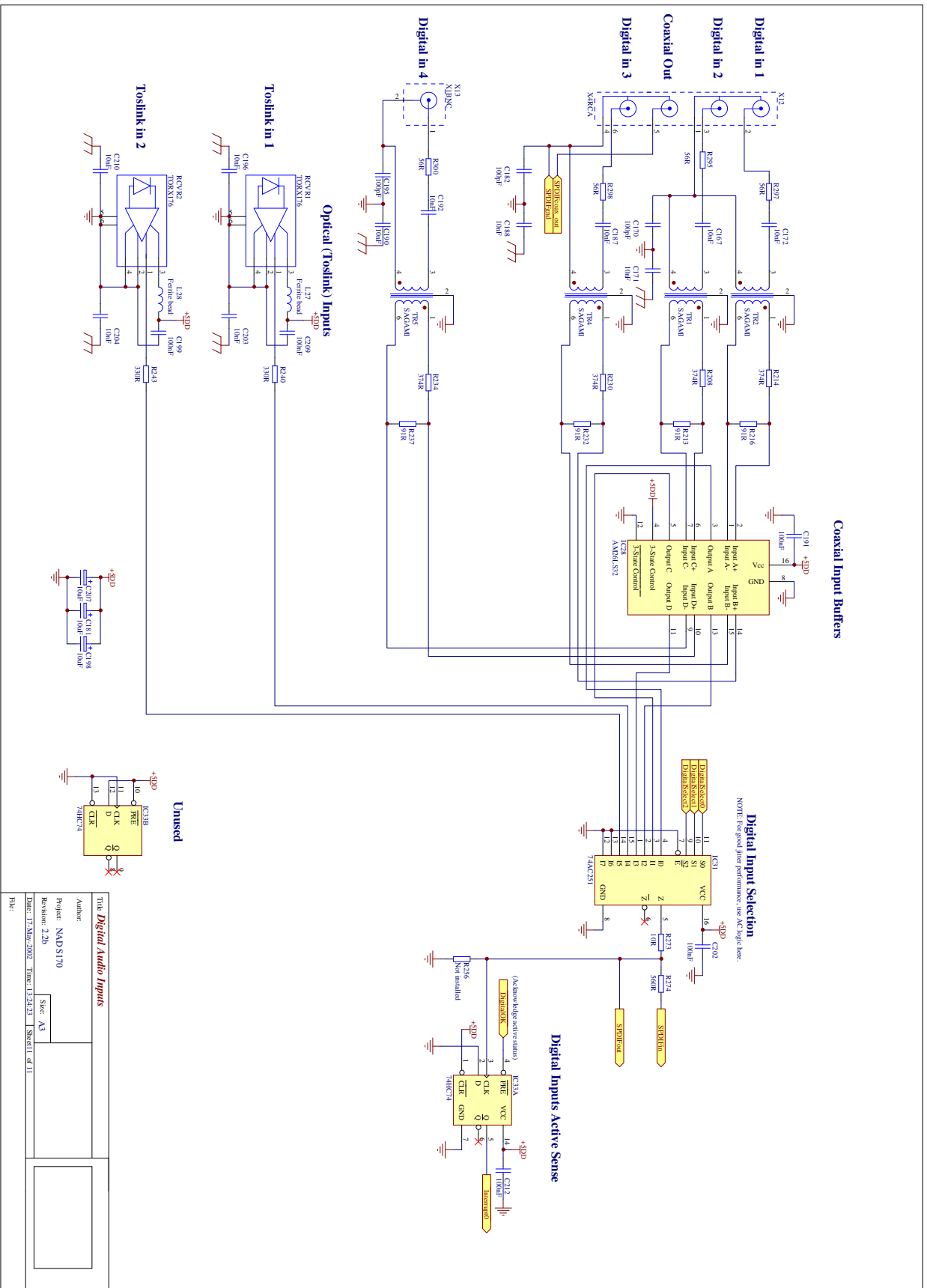

Title Digital Audio Inputs	
Author:	
Project: NADS170	
Revision: 2.2b	
Date: 17-Mar-2002 Time: 13:43:31	Sheet 1 of 1
File:	

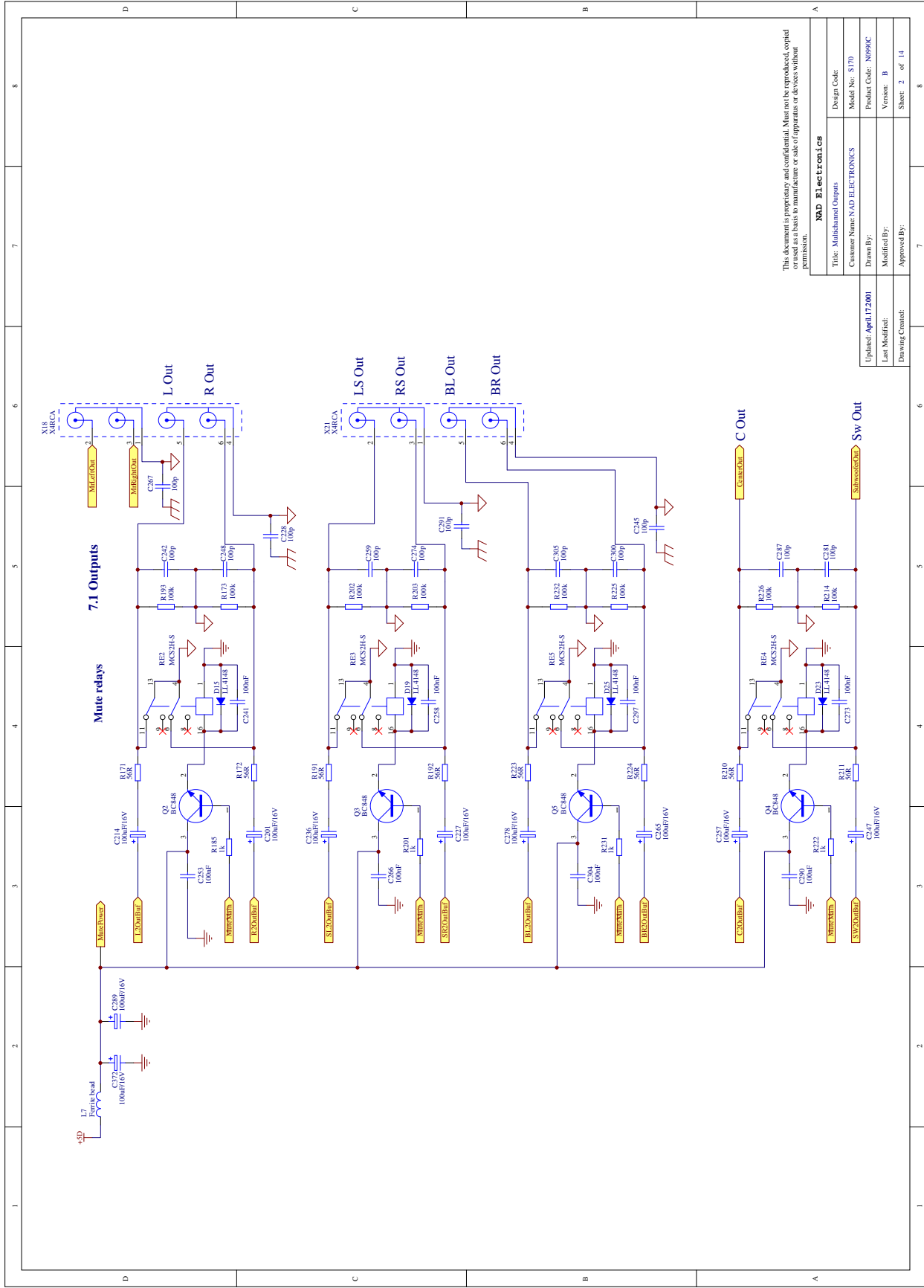

This document is proprietary and confidential. Must not be reproduced, copied or used in any form without the prior written permission of NAD Electronics.

NAD Electronics	
Title: Multichannel Outputs	Design Code:
Customer Name: NAD ELECTRONICS	Model No: S170
Drawn By:	Product Code: N0990C
Last Modified:	Version: B
Approved By:	Sheet: 2 of 14

Updated: April 17, 2001
Drawing Content:

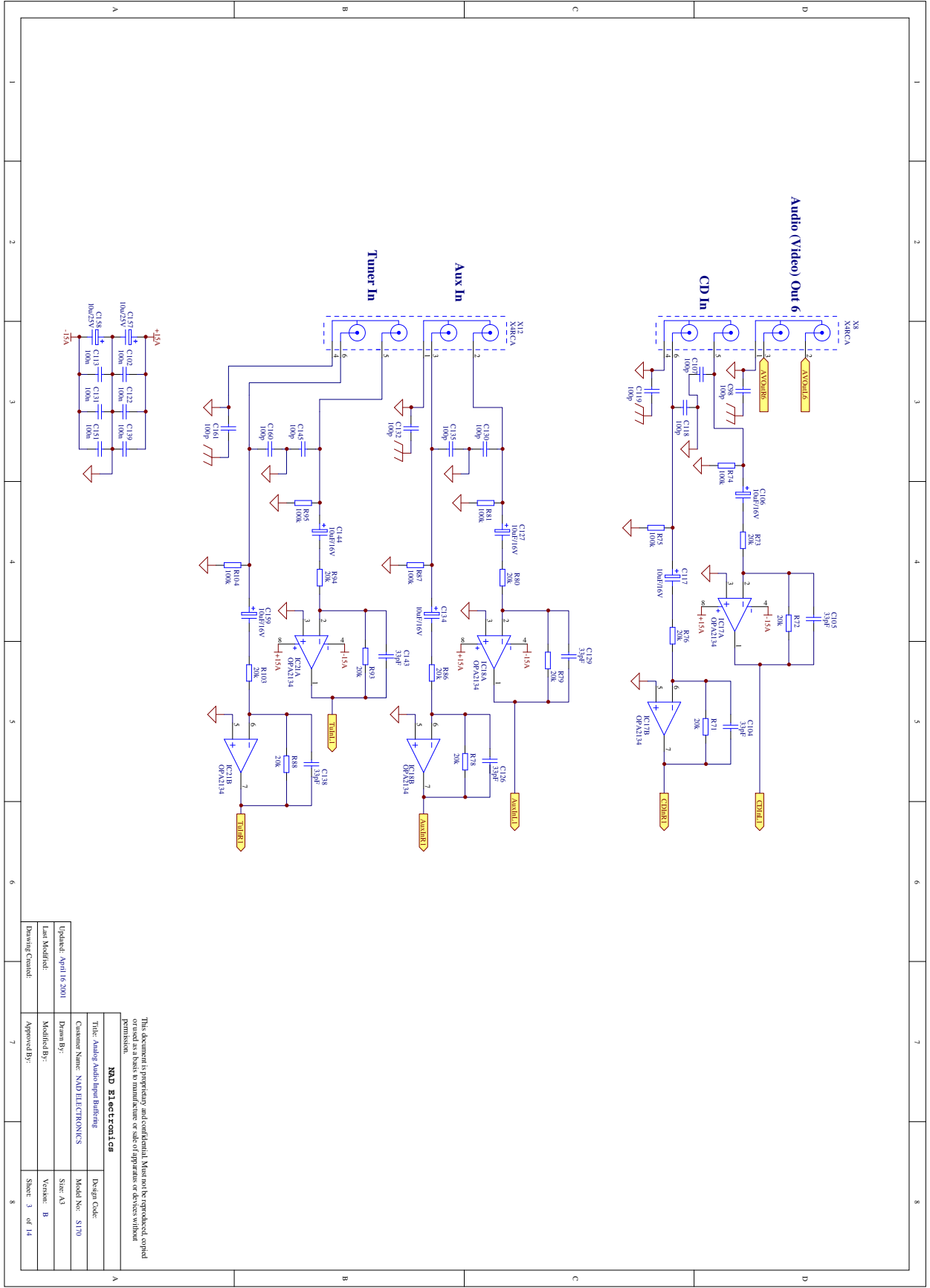

This document is proprietary and confidential. Must not be reproduced, copied or disseminated in any form or by any means to manufacture or sale of apparatus or devices without permission.

NAD Electronics	
Title: Analog Audio Input Buffering	Design Code:
Customer Name: NAD ELECTRONICS	Model No.: S170
Drawn By:	Size: A3
Modified By:	Version: B
Approved By:	Sheet: 3 of 14
Drawing Control:	

7 8

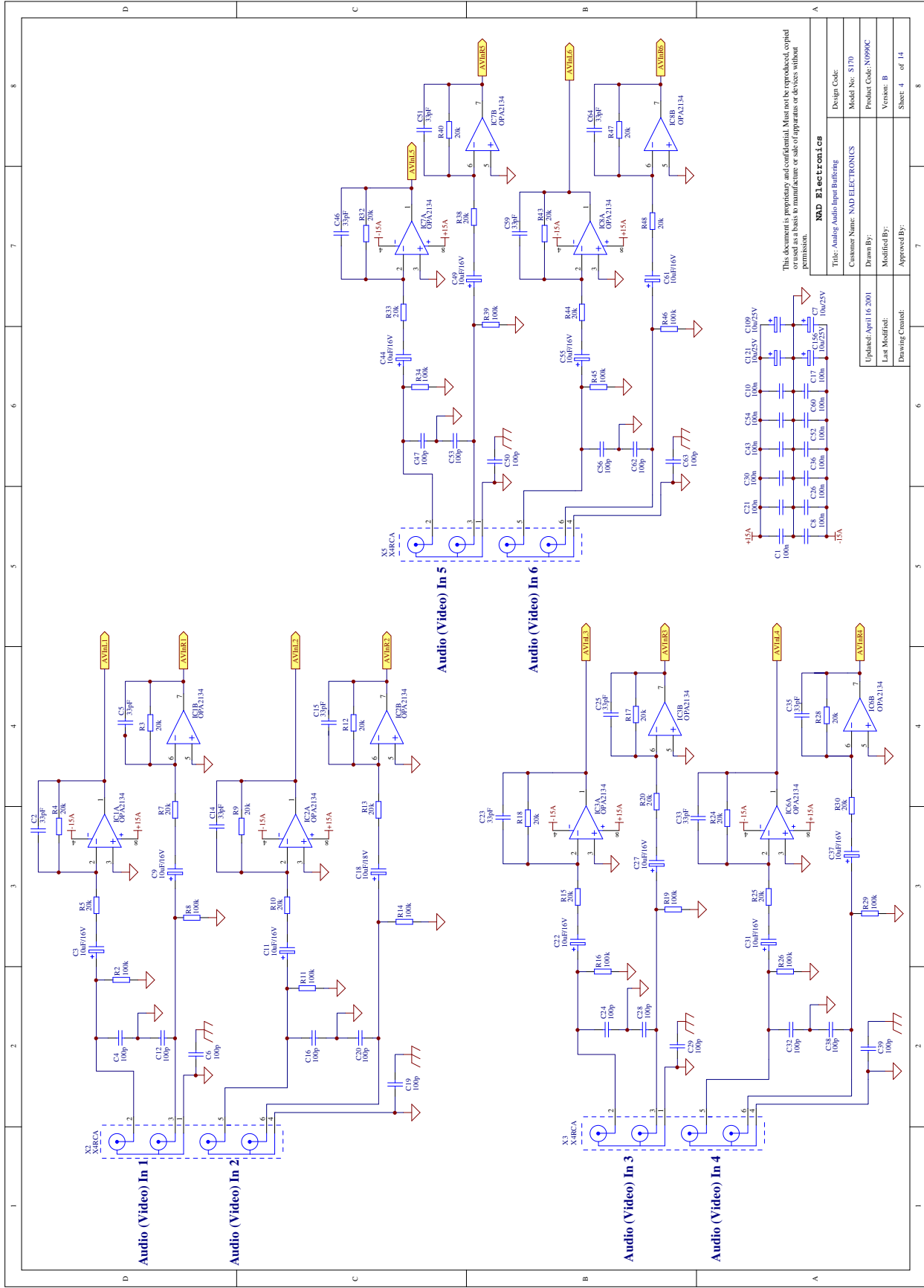

This document is proprietary and confidential. Must not be reproduced, copied or distributed without the prior written permission of NAD Electronics.

NAD Electronics	
Title: Analog Audio Input Buffering	Design Code:
Customer Name: NAD ELECTRONICS	Model No: S170
Drawn By:	Product Code: N0990C
Last Modified:	Version: B
Approved By:	Sheet: 4 of 14

Updated: April 16, 2001
 Last Modified:
 Drawing Created:

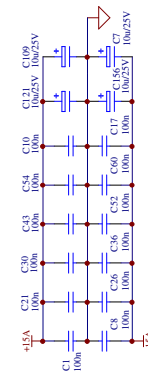

Audio (Video) In 5

Audio (Video) In 6

Audio (Video) In 3

Audio (Video) In 4

Audio (Video) In 1

Audio (Video) In 2

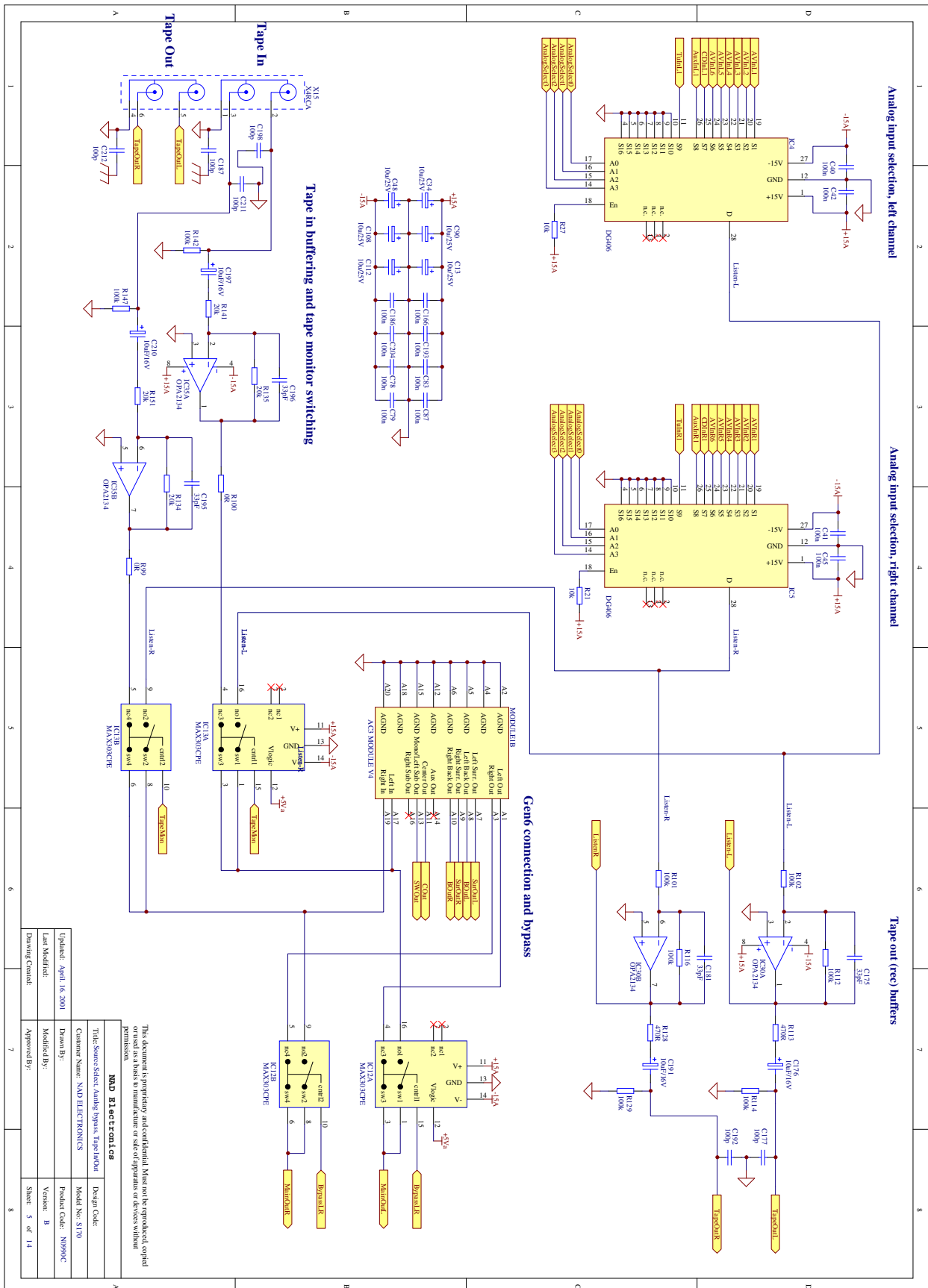

This document is proprietary and confidential. Must not be reproduced, copied, or disseminated in any form or by any means without the express written permission of NAD Electronics.

NAD Electronics	
Customer Name: NAD ELECTRONICS	Design Code:
Drawn By: _____	Model No: S170
Modified By: _____	Product Code: N999C
Version: B	Sheet: 5 of 14
Approved By: _____	Drawing Control:
Updated: April 16, 2001	
Last Modified:	

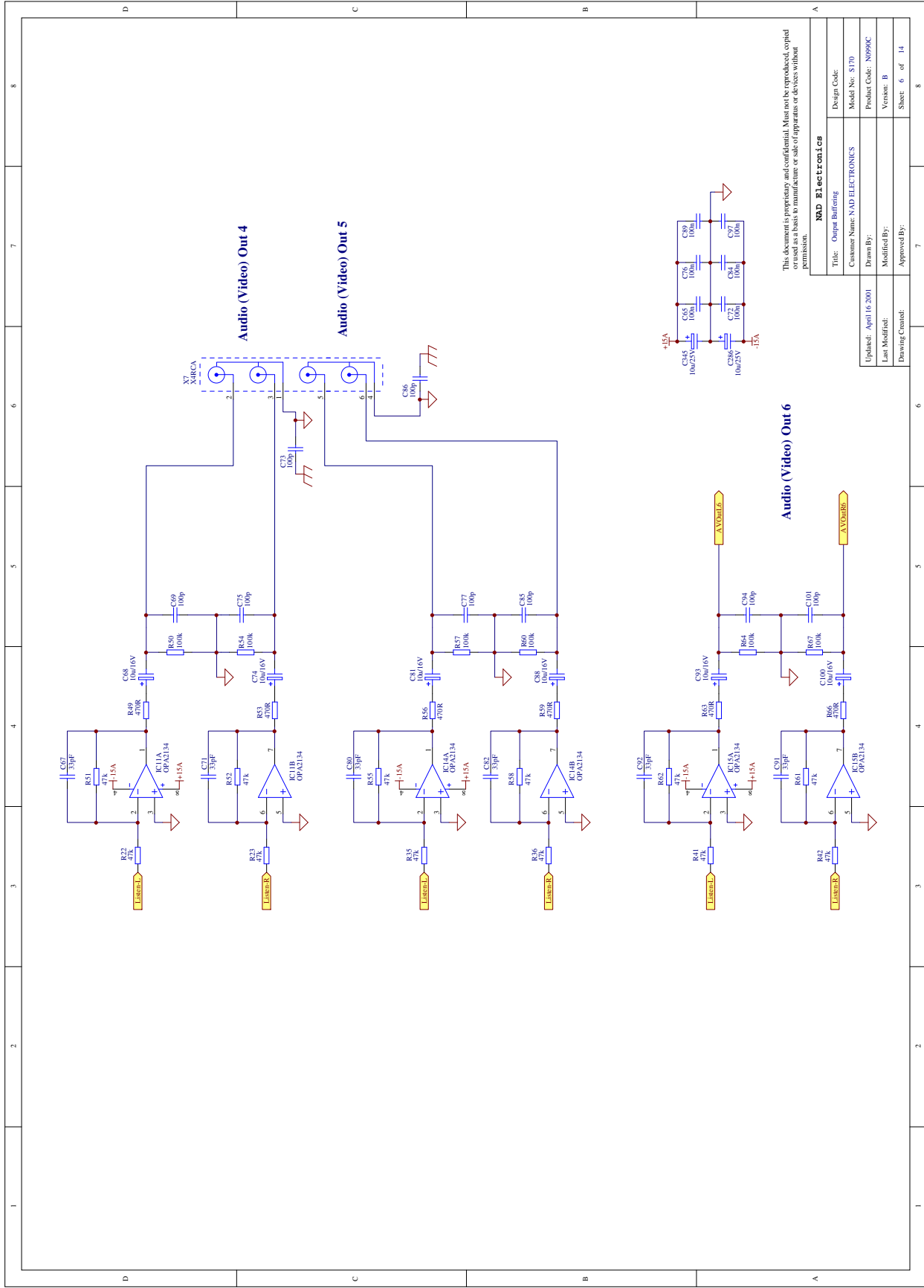

This document is proprietary and confidential. Must not be reproduced, copied or used in any form without the prior written permission of NAD Electronics.

NAD Electronics	
Title: Output Buffering	Design Code:
Customer Name: NAD ELECTRONICS	Model No: S170
Drawn By:	Product Code: N0904C
Last Modified:	Version: B
Drawing Control:	Approved By:
	Sheet: 6 of 14

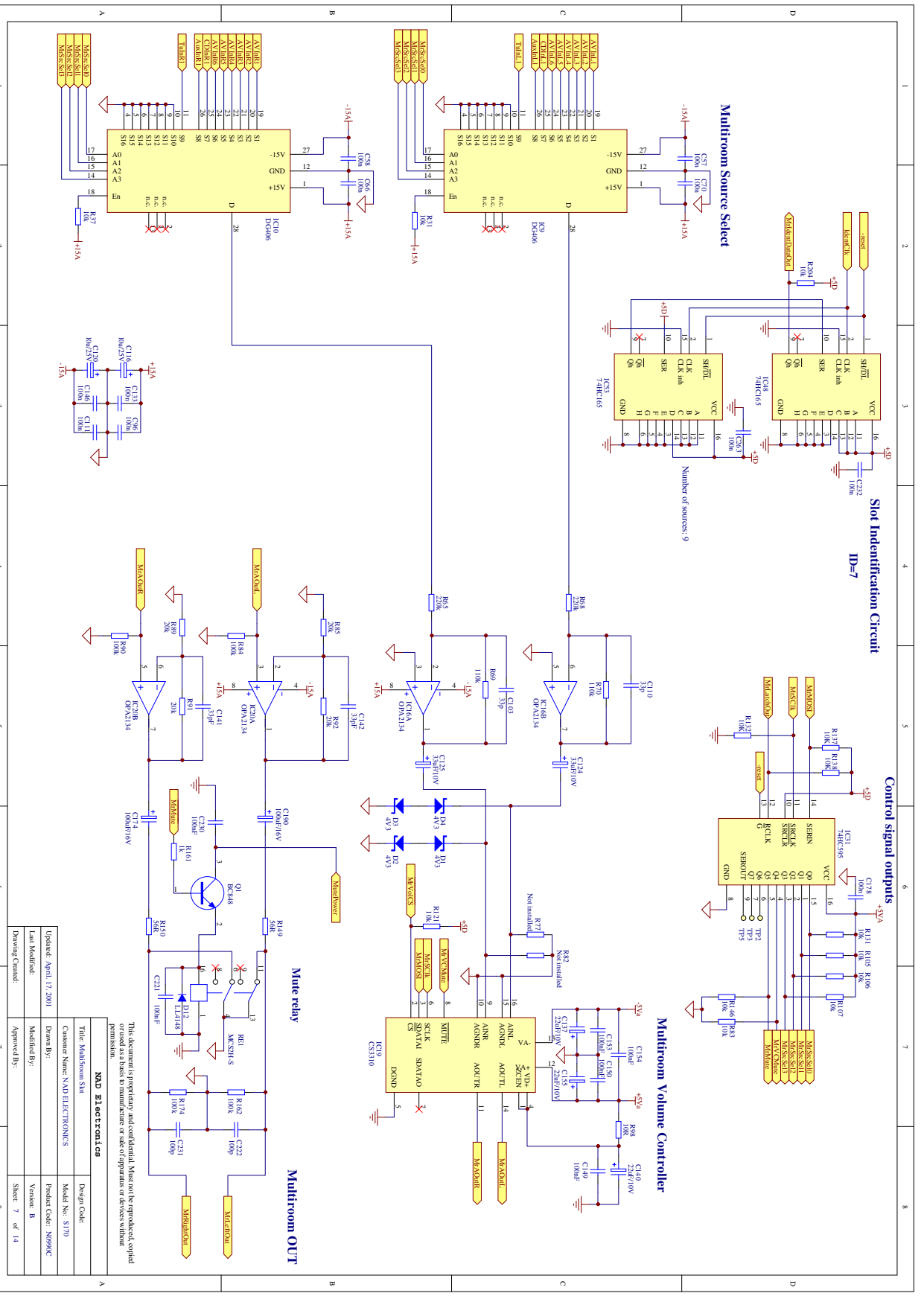

Slot Identification Circuit
ID=7

Control signal outputs
+5V

Multiroom Source Select

Multiroom Volume Controller

Multiroom OUT

Mute relay

This document is proprietary and confidential. Must not be reproduced, copied or disseminated in any form or by any means without the prior written permission.

MND Electronics	
Title: Multiroom Slot	Design Code:
Customer Name: NAD ELECTRONICS	Model No: ST10
Drawn By:	Product Code: N999C
Modified By:	Version: B
Approved By:	Sheet: 7 of 14
Drawing Code:	

Updated: April 17, 2001
Last Modified:
Drawing Code:

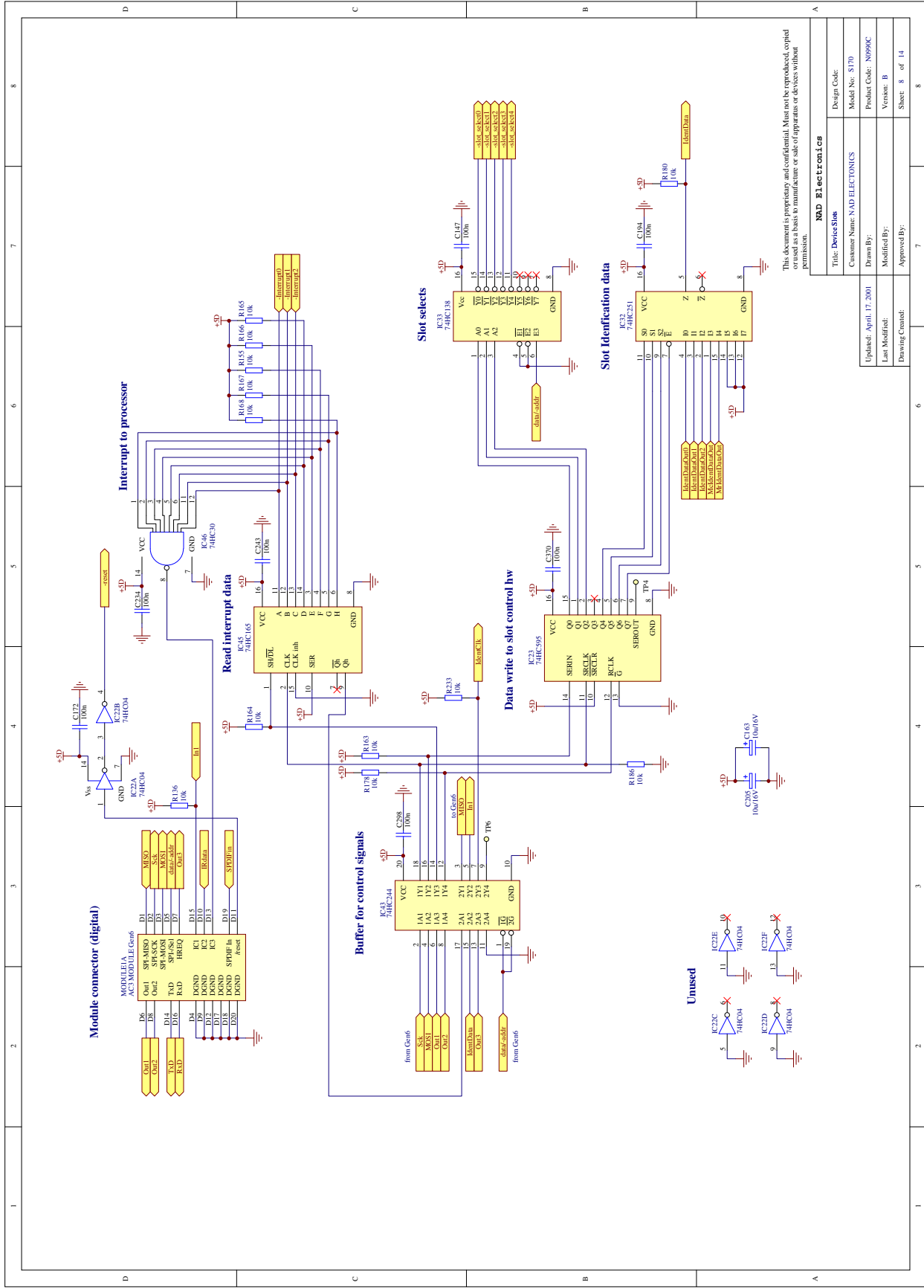

This document is proprietary and confidential. Must not be reproduced, copied or distributed without the prior written consent of the manufacturer or its authorized representative.

NAD Electronics	
Title: Device Slot	Design Code:
Customer Name: NAD ELECTRONICS	Model No: S170
Drawn By:	Product Code: N0990C
Last Modified:	Version: B
Approved By:	Sheet: 8 of 14
Drawing Control:	

1 2 3 4 5 6 7 8

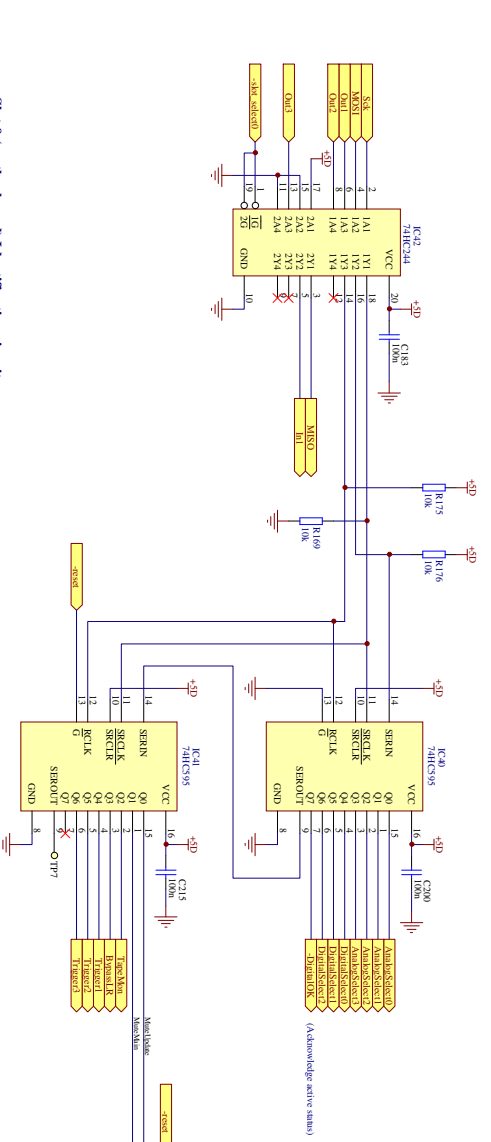

Motherboard data write

Slot 0 (motherboard) Identification circuit

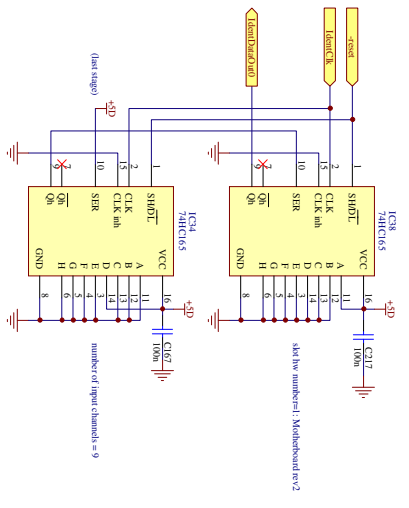

Unused

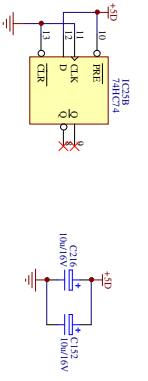

Mute controls

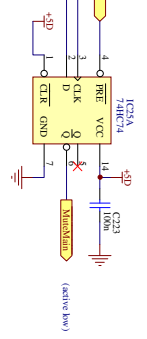

This document is proprietary and confidential. Must not be reproduced, copied, modified, or distributed in any form or by any means without the prior written permission of NAD Electronics.

NAD Electronics	
Design Code:	
Title: CONTROL LOGIC	
Customer Name: NAD ELECTRONICS	Model No: ST10
Drawn By:	Product Code: N999C
Modified By:	Version: B
Approved By:	
Drawing Grade:	Sheet 9 of 14

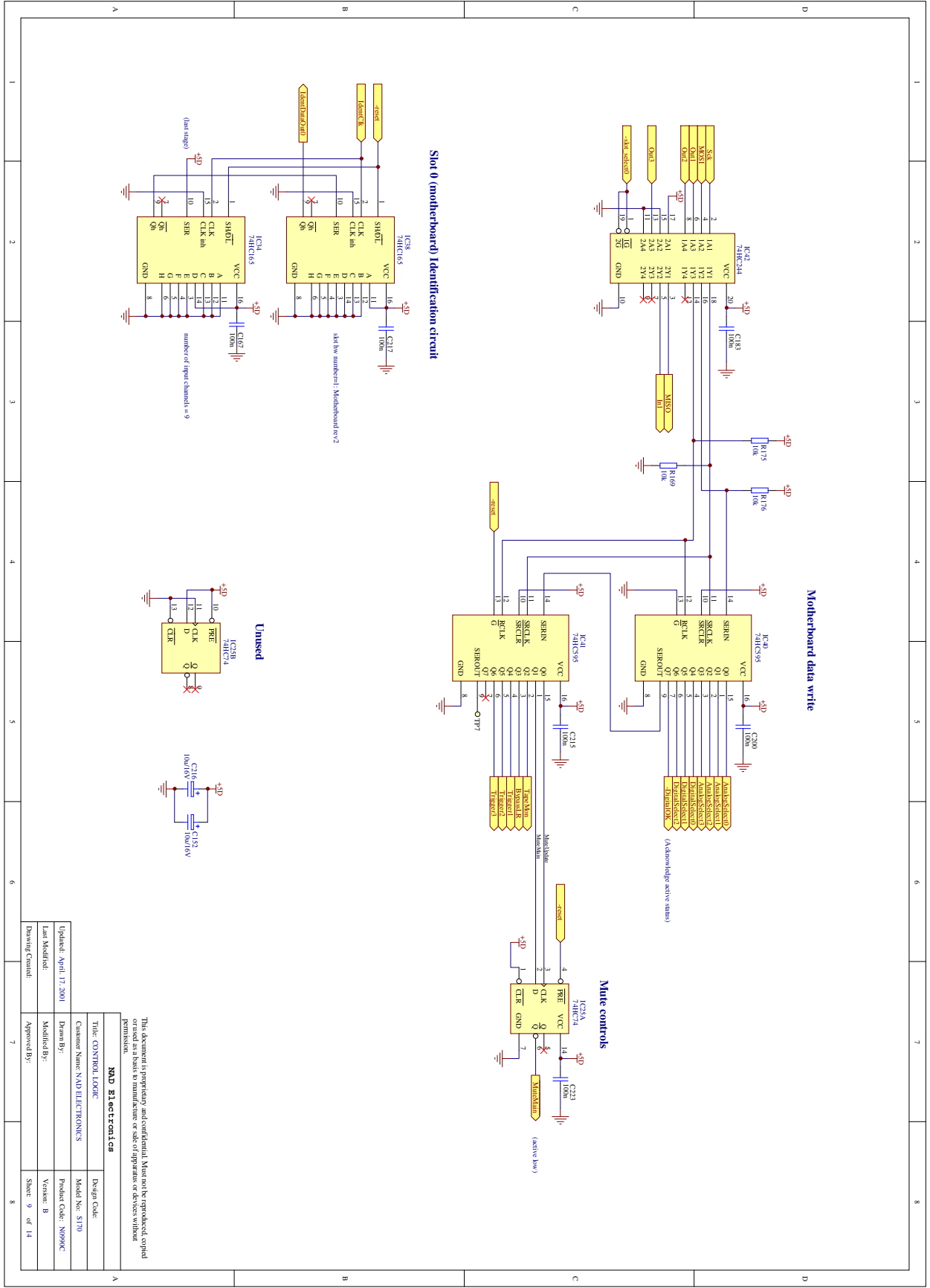

External 5.1 Inputs

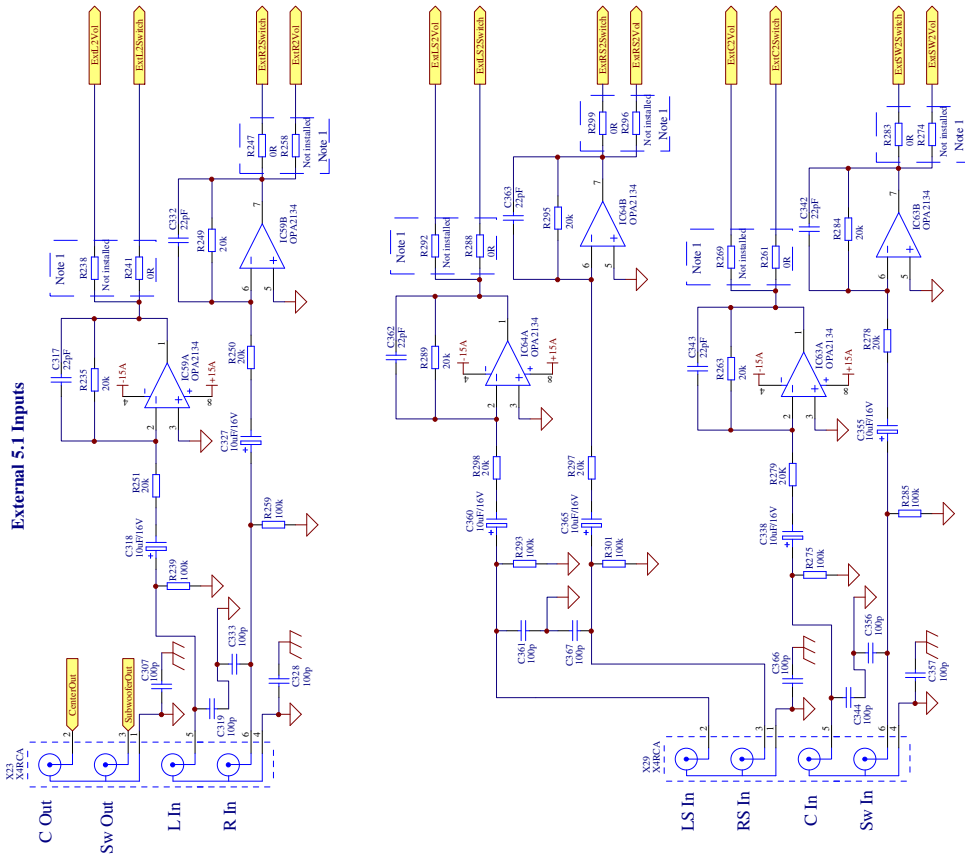

Note 1:
Volume controllers are placed between the wicks and outputs.
If volume controllers are wanted to be placed between
inputs and the wicks, replace uninstalled resistors with
0R and uninstalled 0R's.

This document is proprietary and confidential. Must not be reproduced, copied
or used in any way without the prior written permission of the manufacturer or its
representative.

NAE Electronics	
Title: Multichannel Inputs	Design Code:
Customer Name: NAEELECTRONICS	Model No: S170
Drawn By:	Product Code: N0990C
Last Modified:	Version: B
Approved By:	Sheet: 10 of 14

Updated: April 16, 2001
Drawing Created:

Slot 1 (Frontpanel)

Device Slot buffers and connectors

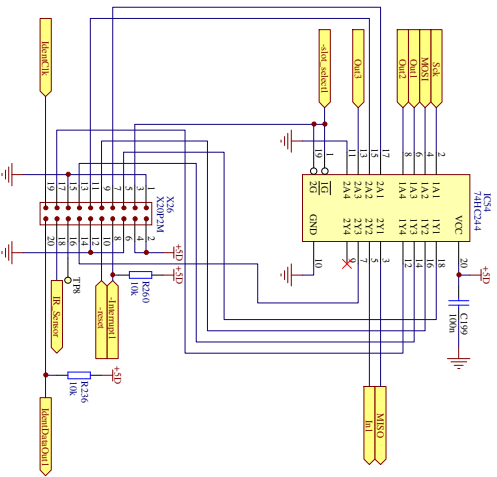

Slot 2 (video board)

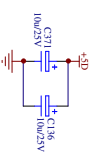
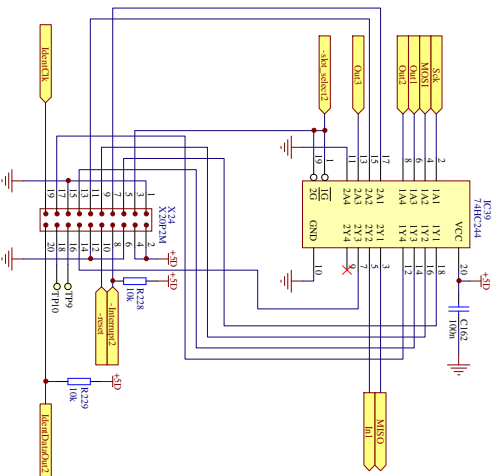

Digital audio connector

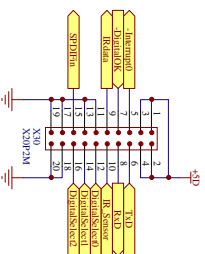

Slot 3 (Multichannel)

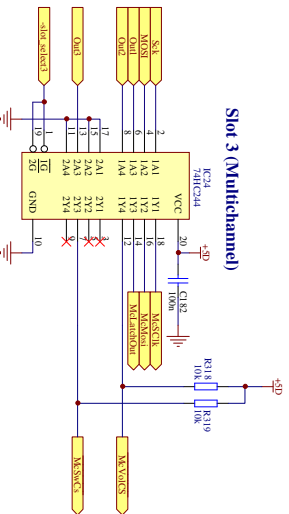

Slot 4 (Multiroom)

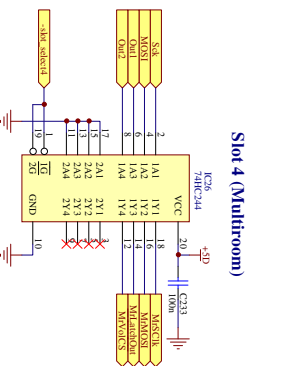

<p>This document is proprietary and confidential. Must not be reproduced, copied or disseminated in any form or by any means to third parties or devices without permission.</p>	
<p>MAD Electronics</p>	
Third Slot connections	Design Code:
Customer Name: MAD ELECTRONICS	Model No: ST10
Drawn By:	Product Code: SMP90C
Modified By:	Version: B
Approved By:	Sheet: 11 of 14
Drawing Control:	

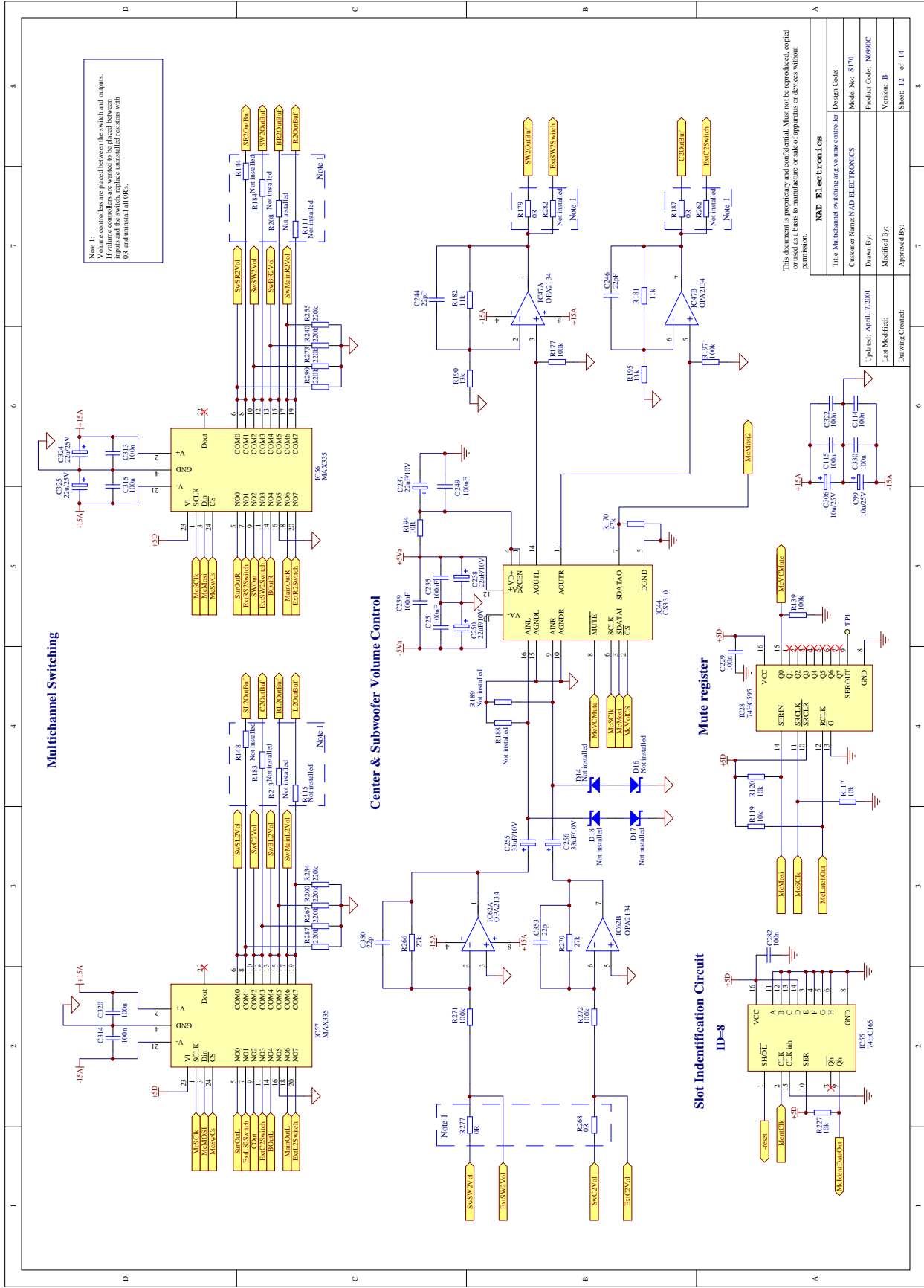

Note 1:
Volume controllers are placed between the switch and outputs.
If volume controllers are wanted to be placed between the switch and outputs, place uninstalled resistors with 0R and uninstalled all OPAs.

This document is proprietary and confidential. Must not be reproduced, copied or distributed without the prior written permission of NAD Electronics.

NAD Electronics
Title: Multichannel switching volume controller
Design Code:
Customer Name: NAD ELECTRONICS
Model No: S170
Product Code: N0990C
Version: B
Update: April 17, 2001
Drawn By:
Last Modified:
Modified By:
Approved By:
Drawing Count: 7
Sheet: 12 of 14

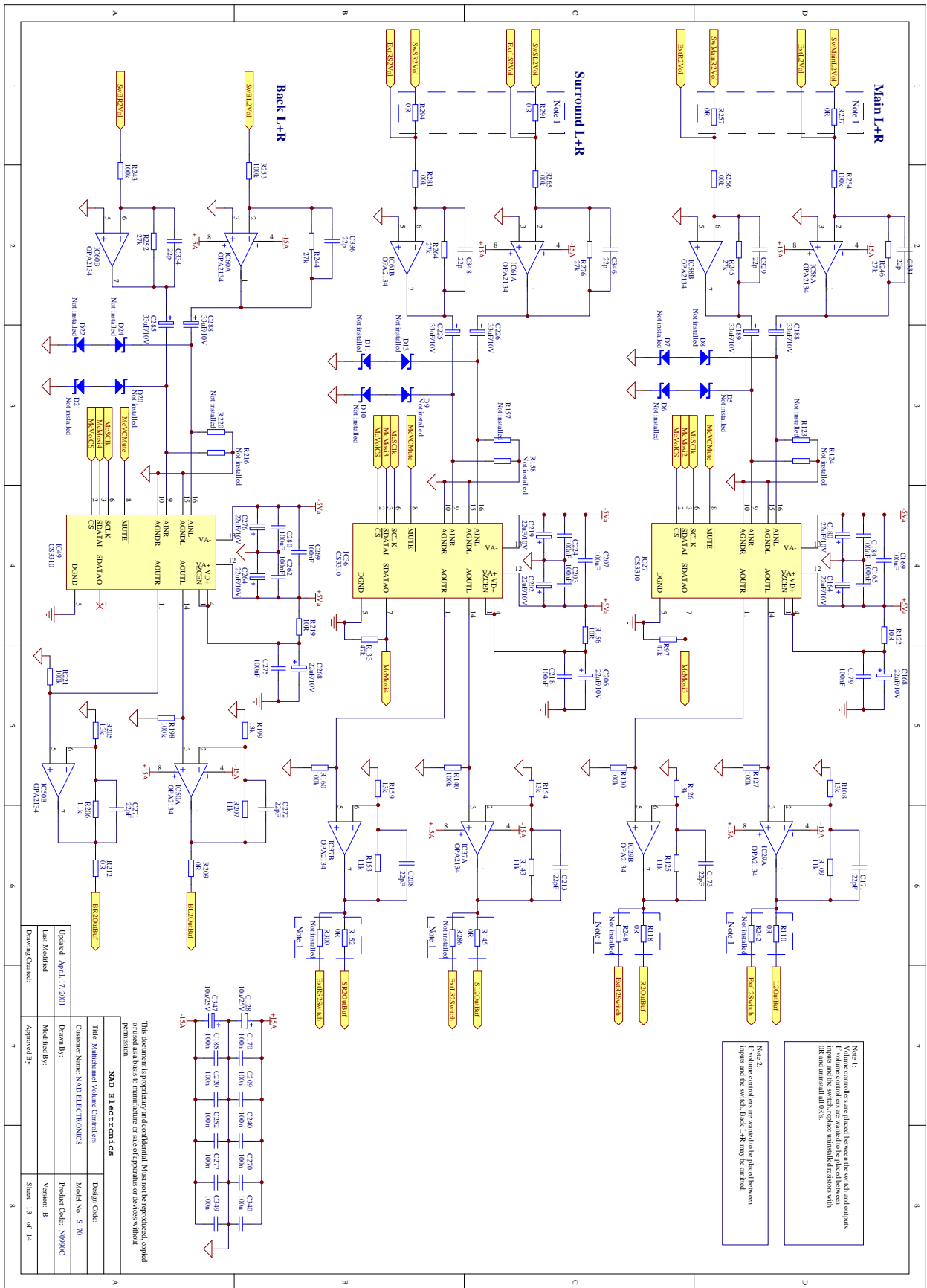

Note 1:
Volume controls are placed between the switch and control inputs and the switch. Replace uninstalled resistors with 0R and uninstalled diodes with 0S.

Note 2:
If volume controllers are wanted to be placed between inputs and the switch, Back L/R may be omitted.

<p>This document is proprietary and confidential. Must not be reproduced, copied, disseminated, or used for manufacturing or sale of apparatus or devices without permission.</p>	
<p>MND Electronics</p>	
Title: Multichannel Volume Controllers	Design Code:
Customer Name: MND ELECTRONICS	Model No: S170
Drawn By:	Product Code: SN99C
Modified By:	Version: B
Approved By:	Sheet: 13 of 14
Drawing Control:	

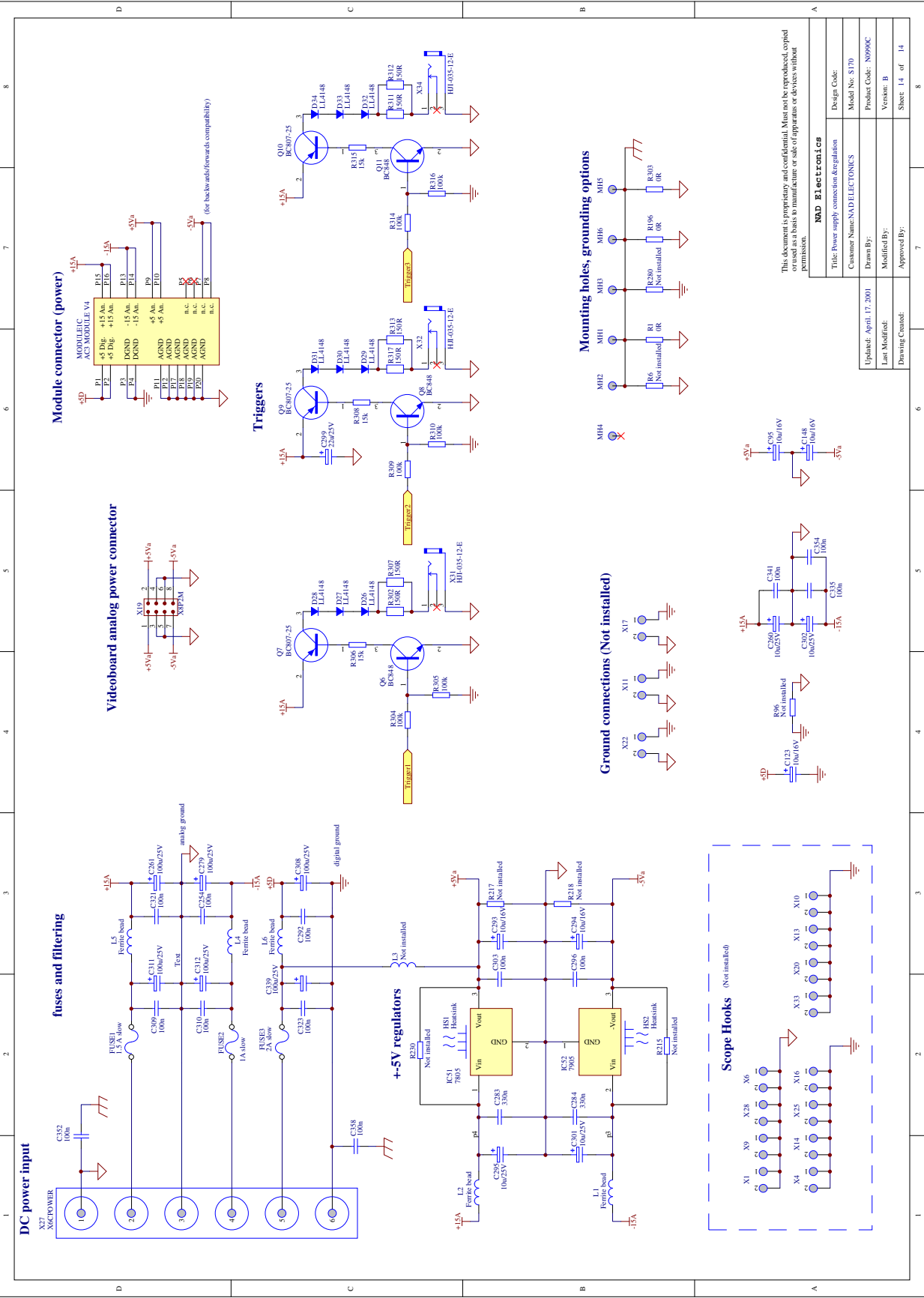

DC power input

fuses and filtering

+5V regulators

Module connector (power)

Videoboard analog power connector

Triggers

Ground connections (Not installed)

Mounting holes, grounding options

Scope Hooks

This document is proprietary and confidential. Must not be reproduced, copied or used in any form without the prior written permission of the manufacturer or its authorized representative.

NAD Electronics	
Title: Power supply connection & regulation	Design Code:
Customer Name: NAD ELECTRONICS	Model No: S170
Updated: April 17, 2001	Product Code: N0990C
Drawn By:	Version: B
Last Modified:	Approved By:
Drawing Count:	Sheet: 14 of 14

ELECTRICAL PARTS LIST

Location	Part Number	Description
<u>PCB ASSY KEY</u> <u>PCB BOARD</u> <u>2000</u>	PCB-N0990C-KEY	PCB ASSY KEY
<u>CAPACITORS</u>		
C38, C39	150F-102K-J-BD	CC 50V 1000pF 10% 0805 1
C40	150F-103K-J-BD	CC 50V 0.01U 10% 0805
C1-C7, C9-C27, C41	150F-104K-J-BD	CC 50V 0.1uF 10% 0805
C35	150F-223K-J-BD	CC 50V 0.022U 10% 0805
C28-C34	154C-107K-3-HN	CT 10V 100uF 10% SM
<u>WAFERS</u>		
S-2	2101-0831-0	WAFER 10PIN P2.54 DUAL
S-1	2101-1369-0	CONN.7x2PIN DUAL ROW
<u>LCD</u> LCD1	2460-1450-0	VF DISPLAY VFD116X37 NOR
<u>IC</u>		
IC4, IC5	3130-6590-0	IC 74HC74 DUAL D-TYPE
IC9	3130-8740-0	IC 74HC138 SOP PACKAGE
IC6	3131-9050-0	IC 74HC00 QUAD 2/P NAND
IC7, IC8	3131-9500-0	IC 74HC595AF 8BIT SHIFT
IC1, IC2, IC3	3131-9520-0	IC 74HC165AF SHIFT
<u>LED</u>		
	3700-3538-B	LED 3MM FLAT TOP BLUE
<u>RESISTOR</u> R37-R46	4720-000J-J	RMG 1/10W 0R 5% 0805

ELECTRICAL PARTS LIST

Location	Part Number	Description
R34	4720-102J-J	RMG 1/10W 1K 5% 0805
R18-R21,R26-R33,R49	4720-103J-J	RMG 1/10W 10K 5% 0805
R11-R13	4720-104J-J	RMG 1/10W 100K 5% 0805
R22,R23	4720-124J-J	RMG 1/10W 120K 5% 0805
R24,R25	4720-203J-J	RMG 1/10W 20K 5% 0805
R36	4720-223J-J	RMG 1/10W 22K 5% 0805
R35	4720-331J-J	RMG 1/10W 330R 5% 0805
R48	4720-471A-J	RMG 1/10W 470R 1% 0805
R1-R10,R14-R16	4720-472J-J	RMG 1/10W 4.7K 5% 0805
R17	4720-473J-J	RMG 1/10W 47K 5% 0805
R47	4720-682J-J	RMG 1/10W 6.8K 5% 0805
<u>DIODES</u>		
D1-D15	4840-1080-3	RLS-73 DIODE
<u>TRANSISTOR</u>		
Q1	485C-848C-3	TR BC848C (1LP) HFE
<u>SWITCH</u>		
SW1-SW10	5200-3011-0-01	TACT SWITCH 4P
<u>MISCELLANEOUS</u>		
REC1	4152-4671-0	RUBBER PAD 8X8X3
REC1	481P-1736-0	IR RECEIVER TSOP1736
<u>PCB ASSY VOLUME</u>		
<u>PCB BOARD</u>	PCB-N0990C-KEY1	PCB ASSY VOLUME
<u>WAFERS</u>		
J207A	2101-1375-0	WAFER 3PIN P2/54 STRIGHT
<u>SEMI FIXED</u>		
M301	4750-6000-0	ROTARY ENCODER

ELECTRICAL PARTS LIST

Location	Part Number	Description
<u>PCB ASSY MAIN N0990C</u>		
<u>PCB BOARD</u>		
<u>CAPACITORS</u>		
C283,C284	150E-334K-J-BD	CC 25V 0.33uF 10% 0805
C4,C6,C12,C16,C19,C20,C24, C28,C29,C32,C38,C39,C47, C50,C53,C56,C62,C63,C69, C73,C75,C77,C85,C86,C94, C98,C101,C107,C118,C119, C130,C132,C135,C145,C160, C161,C177,C187,C192,C198, C211,C212,C222,C228,C231, C242,C245,C248,C259,C267, C274,C281,C287,C291,C300, C305,C307,C319,C328,C333, C344,C356,C357,C361,C366, C367,	150F-101K-J-BD	CC 50V 100P 10% 0805
C101,C111,C113,C136,C140, C301,C302,C310,C322,C350, C380,C381,C386,C401, C403-C405,C412,C417, C501-C505,C521,C526,C528, C532,C534,C535,C540-C543, C703	150F-104K-5-II	CC 50V 0.1uF 10% RL 5x5
C1,C8,C10,C17,C21,C26,C30, C36,C40-C45,C52,C54,C57, C58,C60,C65,C66,C70,C72, C76,C78,C79,C83,C84,C87, C89,C96,C97,C102,C111, C113-C115,C122,C131,C133, C139,C146,C147,C149-C151,	150F-104K-J-BD	CC 50V 0.1uF 10% 0805

ELECTRICAL PARTS LIST

Location	Part Number	Description
C153,C154,C162,C165,C166, C167,C169,C170,C172,C178, C179,C182,C183,C184-C186, C193,C194,C199,C200,C203, C204,C207,C209,C215,C217, C218,C220,C221,C223,C224, C229,C230,C232-C235, C239-C241,C243,C249, C251-C253,C254,C258,C262, C263,C266,C269,C270,C273, C275,C277,C280,C282,C290, C292,C296,C297,C298,C303, C304,C309,C310,C313-C316, C320-C323,C326,C330,C335, C337,C340,C341,C349,C351, C352,C354,C358,C359,C364, C370, C343	150F-220K-J-BD 150F-330J-J-BD	CC 50V 22P 10% 0805 CC 50V 33pF 5% 0805 1.2x
C2,C5,C14,C15,C23,C25, C33,C35,C46,C51,C59,C64, C67,C71,C80,C82,C91,C92 C103-C105,C110,C126,C129, C138,C141,C142,C143, C175,C181,C195,C196, C188,C189,C225,C226, C255,C256,C285,C288 C95,C123,C148,C152,C163, C205,C216,C293,C294, C7,C13,C34,C48,C90,C99 C108,C109,C112,C116,C120, C121,C128,C136,C156-C158, C260,C286,C295,C301,C302, C306,C345,C347,C368,C369, C371, C137,C140,C155,C164,C168,	154C-336M-3-EF 154D-106M-3-EF 154E-106M-3-FK	CT 10V 33uF 20% SM CT 16V 10uF 20% SM CT 25V 10uF 20% 3.2x6 SM
	157C-226M-3-JJ	CE 10V 22uF 20% 5.3x5.4

ELECTRICAL PARTS LIST

Location	Part Number	Description
C180, C202, C206, C219, C237, C238, C250, C264, C268, C276 C124, C125	157C-336M-3-JJ 157D-106M-3-GJK	CE 10V 33uF 20% 5.3x5.4 CE 16V 10uF 20% 4X5.4 SM
C3, C9, C11, C18, C22, C27, C31, C37, C44, C49, C55, C61, C68, C74, C81, C88, C93, C100, C106, C117, C127, C134, C144, C159, C176, C191, C197, C210, C318, C327, C338, C355, C360, C365, C174, C190, C201, C214, C227, C236, C247, C257, C265, C278, C289, C372 C261, C279, C308, C311, C312, C339	157D-107M-3-MJ 157E-107M-3-OJ	CE 16V 100uF 20% SM CE 25V 100uF 20% 8X5.5
C299, C324, C325 C171, C173, C208, C213, C244, C246, C271, C272, C317, C329, C331, C332, C334, C336, C342, C346, C348, C350, C353, C362, C363	157E-226M-3-LJ 15CG-220J-JBD	CE 25V 22uF 20% 6.3X5.4 CTC 0/30 22pF 5% 0805
<u>WAFERS/JACKS</u>		
A, C, B	2101-0821-0	10 PIN P2.54 CONNECTOR
X26, X24, X30	2101-0831-0	WAFER 10PIN P2.54 DUAL
X27	2101-1367-0	WAFER 6P P5.0 STRAIGHT
X19	2101-1368-0	REDEPTACLE 8PIN DUAL
X17	2102-8002-3-100	WAFER 2 PIN 9MM
X31, X32, X34	2113-1743-0	MONO JACK HTJ-035-12E
X2, X3, X5, X7, X8, X12X15, X18, X21, X29	2113-1750-0	4P RCA JACK RW GOLD
X29	2113-1756-0	RCA JACK 4P W/R.BL GOLD
X23	2113-1757-0	RCA JACK 4P BL.W/R GOLD
<u>IC</u>		
IC51	3130-2020-3	IC 7805 REG 5V 1.5A
IC52	3130-6360-0	IC 7905 -5V REG 1.5A

ELECTRICAL PARTS LIST

Location	Part Number	Description
IC25	3130-6590-0	IC 74HC74 DUAL D-TYPE
IC33	3130-8740-0	IC 74HC138 SOP PACKAGE
IC19,IC27,IC36,IC44,IC49,	3130-8860-0	IC CSS3310 STEREO DIGITAL
IC4,IC5,IC9,IC10	3131-7260-0	IC DG506A SOP8 SMD
IC56,IC57	3131-7270-0	IC MAX335 SOP24 SMD
IC24,IC26,IC39,IC42,IC43,IC54	3131-7280-0	IC 74HC244 10x13 SOP20
IC32	3131-7290-0	IC 74HC251 SOP16
IC46	3131-7300-0	IC 74HC30 8-INPUT NAND
IC1-IC3,IC6-IC8,IC11,IC14-IC18,	3131-7310-0	IC OPA2134 SOP8 SMD
IC20,IC21,IC29,IC30,IC35,IC37		
IC47,IC50,IC58-IC64		
IC12,IC13	3131-7320-0	IC MAX303CPE SWITCH
IC22	3131-7340-0	IC 74HC04 HEX INVERTERS
IC31,IC41	3131-7570-0	IC 74HC594 8 bit SHIFT
IC28,IC23,IC40	3131-9500-0	IC 74HC595AF 8BIT SHIFT
IC34,IC38,IC45,IC48,IC53,IC55	3131-9520-0	IC 74HC165AF SHIFT
<u>RELAY</u>		
RE1-RE5	4500-0420-0	RELAY MCSS2H-S
<u>RESISTOR</u>		
X31C,X32C,X34C	4715-472A-2	RMF 1/4W 4.7K 1% AT
R302,R307,R311-R313,R317	4719-101J-1-P	RMF 2W 100R 5% AL FP
R1,R99,R100,R110,R118,	4720-000J-J	RMG 1/10W 0R 5% 0805
R145,R152,R179,R187,R196,		
R209,R212,R237,R241,R247,		
R257,R261,R268,R277,R283,		
R288,R291,R294,R299,R303,		
R98,R122,R156,R194,R219	4720-100J-J	RMG 1/10W 10R 5% 0805
R161,R185,R201,R222,R231	4720-102J-J	RMG 1/10W 1K 5% 0805
R21,R27,R31,R37,R83,	4720-103J-J	RMG 1/10W 10K 5% 0805
R105-R107,R117,R119-R121,		
R131,R132,R136-R138,		
R146,R155,R163-R169,		
R175,R176,R178,R180,R186,		

ELECTRICAL PARTS LIST

Location	Part Number	Description
R204, R227, R229, R233, R236, R260, R318, R319, R2, R8, R11, R14, R16, R26, R29, R34, R39, R45, R46, R50, R54, R57, R60, R64, R67, R74, R75, R81, R84, R87, R90, R95, R101, R102, R104, R112, R114, R116, R127, R129, R130, R140, R142, R147, R160, R162, R173, R174, R177, R193, R197, R198, R202, R203, R214, R221, R225, R226, R232, R239, R259, R271, R272, R275, R285, R293, R301, R19, R139, R304, R305, R309, R310, R314, R316	4720-104A-J	RMG 1/10W 100K 1% 0805
R109, R125, R143, R153, R206, R207	4720-113A-J	RMG 1/10W 11K 1% 0805
R69, R70	4720-114A-J	RMG 1/10W 110K 1% 0805
R108, R126, R154, R159, R199, R205	4720-133A-J	RMG 1/10W 13K 1% 0805
R306, R308, R315	4720-153J-J	RMG 1/10W 15K 5% 0805
R181, R182	4720-163J-J	RMG 1/10W 16K 5% 0805
R3, R4, R5, R7, R9, R10, R12, R13, R15, R17, R18, R20, R24, R25, R28, R30, R32, R33, R38, R40, R43, R44, R47, R48, R71-R73, R76, R78, R79, R80, R85, R86, R88, R89, R91-R94, R103, R134, R135, R141, R151, R235, R249-R251	4720-203A-J	RMG 1/10W 20K 1% 0805
R263, R278, R279, R284, R289, R295, R297, R298, R65, R68, R200, R234, R240, R255, R267, R273, R287, R290	4720-224A-J	RMG 1/10W 220K 1% 0805
R218	4720-272J-J	RMG 1/10W 2.7K 5% 0805

ELECTRICAL PARTS LIST

Location	Part Number	Description
R266, R270	4720-273A-J	RMG 1/10W 27K 1% 0805
R244, R245, R246, R252, R264, R276	4720-333A-J	RMG 1/10W 33K 1% 0805
R113, R128, R49, R53, R56, R59, R63, R66	4720-471A-J	RMG 1/10W 470R 1% 0805
R170, R22, R23, R35, R36, R41, R42, R51, R62, R61, R52, R55, R58	4720-473A-J	RMG 1/10W 47K 1% 0805
R133, R97	4720-473J-J	RMG 1/10W 47K 5% 0805
R149, R224, R223, R211, R210, R192, R191, R172, R171, R150	4720-560A-J	RMG 1/10W 56R 1% 0805
R190, R195	4720-822J-J	RMG 1/10W 8.2K 5% 0805
R265, R256, R281, R243, R253, R254	4720-823A-J	RMG 1/10W 82K 1% 0805
<u>DIODES</u>		
D12, D15, D19, D23, D25-D34 D1-D4	4804-1480-3 4837-4B31-3	DIODE LL4148 SM DZ 1/2W 4.17-4.43V
<u>TRANSISTOR</u>		
Q7, Q9, Q10 Q1-Q6, Q8, Q11,	485C-8070-3 485C-848C-3	TR BC807-25 SOT23 SMD TR BC848C (1LP) HFE
<u>HEATSINKS</u>		
IC51/52	5400-3421-0	HEAT SINK
<u>MISCELLANEOUS</u>		
L1-L7	1808-0680-0	FERRITE BEAD INDUCTOR
IC51/52	2954-3008-0000	TAPPING 3X8MM B-TITE
FUSE2, FUSE1, FUSE3	4132-1011-0	FUSE HOLDER

PCB ASSY POWER SWITCH **PCB BOARD**

ELECTRICAL PARTS LIST

Location	Part Number	Description
<u>PCB ASSY POWER SWITCH</u> <u>PCB BOARD</u>	PCB-N0990C-PSW	PCB ASSY POWER SWITCH
<u>CAPACITORS</u>		
C761	8910-0049-0	CAP400V 4700P
<u>SWITCH</u>		
	5200-0961-0-01	SW-PWR ALPS
<u>MISCELLANEOUS</u>		
C761	1660-0700-0	INSULATING BOOT (ID=14)
P1A	7012-6300-0	WIRE CON ASSY L=300MM
<u>PCB ASSY VIDEO N0990C</u> <u>PCB BOARD</u> <u>3000</u>	PCB-N0990C-VID	PCB ASSY VIDEO N0990C
<u>CAPACITORS</u>		
C33, C34, C39, C41, C52, C54, C55, C57, C66, C67, C83, C85, C106, C141, C243, C244	150D-225K-6-CF	CC 16V 2.2uF 10% 1206
C170, C174, C182, C195		
C242	150F-101K-J-BD	CC 50V 100P 10% 0805
C38, C49, C53, C60, C63, C73	150F-102K-J-BD	CC 50V 1000pF 10% 0805 1
C161, C171, C186, C188, C189, C190, C196, C200, C203, C204, C210,	150F-103K-J-BD	CC 50V 0.01U 10% 0805
C4, C12, C13, C21, C23, C28		
C31, C35, C43, C46, C50, C56, C61, C62, C69, C70, C75, C78, C79, C101, C104, C105, C109, C110, C112, C113, C118, C120, C121, C125, C129, C131, C132, C136, C142, C143, C146, C158, C160, C165, C167, C169, C172, C173, C175, C176, C177, C179,	150F-104K-J-BD	CC 50V 0.1uF 10% 0805

ELECTRICAL PARTS LIST

Location	Part Number	Description
C180, C184, C187, C191-C194, C197, C199, C201, C202, C205, C209, C212, C213, C216, C218, C221, C222, C232, C236,	150F-221K-J-BD	CC 50V 220pF 10% 0805 1.
C139	150F-223K-J-BD	CC 50V 0.022U 10% 0805
C134	150F-270K-J-BD	CC 50V 27P 10% 0805
C214, C219	154C-225K-3-CF	CT 10V 2.2UF 10% SM
C149	154D-106M-3-EF	CT 16V 10uF 20% SM
C123, C166, C181, C198,	154D-226M-3-FK	CT 16V 22UF 20% SM
C206, C207, C223	154E-106M-3-FK	CT 25V 10uF 20% 3.2x6 SM
C225	157C-107M-3-LJ	CE 10V 100uF 20% SM
C215, C217, C220, C224		
C1-C3, C5-C11, C14-C18,		
C32, C42, C44, C45, C47, C48,		
C51, C58, C59, C64, C68, C71,		
C72, C81, C82, C84, C87-C89,		
C90, C93, C94, C107, C119, C124,		
C130, C133, C135, C137, C147,		
C150, C151, C153, C157, C159,		
C178, C208, C211, C22, C241,		
C138, C148, C155, C162, C183		
C164	157C-477M-5-OU	CE 10V 470UF 20% RL 8X11
C156, C168	15CG-220J-J-BD	CTC 0/30 22pF 5% 0805
C152, C154, C231	15CG-330J-J-BD	CTC 0/30 33pF 5% 0805
C185, C227	15CH-3R9D-J-BD	CTC 0/60 3.9pF 0.5pF
	15CH-8R2D-J-BD	CTC 0/60 8.2pF 0.5pF
<u>COILS</u>		
TR1, TR2, TR3, TR4, TR5	1806-2430-0	DIGITAL COIL 980986540
<u>WAFERS/JACKS</u>		
X14, X16	2101-0831-0	WAFER 10PIN P2.54 DUAL
X11, X15	2101-1368-0	REDEPTACLE 8PIN DUAL
X3	2113-1121-0	2P RCA JACK Y/Y AU
X4, X6, X8	2113-1744-0	DIN JACK MIN 2P
X17	2113-1749-0	DB9 FEMALE D SUB RA

ELECTRICAL PARTS LIST

Location	Part Number	Description
X1,X2	2113-1752-0	RCA JACK 4P Y.Y.GOLD
X9	2113-1753-0	RCA JACK 4P G.B. GOLD
X12	2113-1754-0	RCA JACK 4P BL.BL. GOLD
X10	2113-1755-0	RCA JACK 4P R.O. GOLD
X7,X5	2113-1758-0	SVHS JACK
<u>CRYSTAL</u>		
CR4	2300-1240-0	CRYSTAL 12MHZ
CR3	2300-1980-0	CRYSTAL OSCILLATOR EPSON
CR2	2300-2000-0	CRYSTAL 17.734475 MHZ
CR1	2300-3020-0	XTAL 14.318MHZ +-20PPM
<u>IC</u>		
IC1-IC3,IC7,IC8,IC10, IC12,IC21,IC22,IC25	3130-1730-0	IC HCF4066BM1
IC26	3130-4990-0	IC LM393D DUAL VOLTAGE
IC35	3130-6410-0	IC Z86E08 OTP
IC33	3130-6590-0	IC 74HC74 DUAL D-TYPE
VR1	3130-7010-0	IC LM431ACZ ADJ REG
IC24	3131-3520-0	IC STV5730A OSD
IC30	3131-7280-0	IC 74HC244 10x13 SOP20
IC4,-IC6,IC11,IC14-IC18, IC20,IC23,	3131-7330-0	IC OPA2652 DUAL OP-AMP
IC28	3131-7350-0	IC AM26LS32 SOP16 SMD
IC37	3131-7360-0	IC MAX4599EXT-T ANALOG
IC27	3131-7370-0	IC 74AC04 HEX INVERTERS
IC31	3131-7380-0	IC 74AC251 8-INPUT
IC29	3131-9200-0	IC XC9536PC44 PLCC-44
IC36	3131-9470-0	IC MAX232D SO16
IC9,IC13,IC19, IC32	3131-9500-0	IC 74HC595AF 8BIT SHIFT
	3131-9520-0	IC 74HC165AF SHIFT
<u>RESISTOR</u>		
R230,R214,R208,R205,R78, R73,R3,R294,R290,R289,	4720-000J-J	RMG 1/10W 0R 5% 0805

ELECTRICAL PARTS LIST

Location	Part Number	Description
R288, R252, R245, R234, R233, R231	4720-100J-J	RMG 1/10W 10R 5% 0805
R273	4720-101J-J	RMG 1/10W 100R 5% 0805
R199, R201, R202	4720-102A-J	RMG 1/10W 1K 1% 0805
R21, R26, R28, R44, R46, R47, R53, R88, R110, R111, R115, R121, R122, R131, R132, R136, R141, R142, R145, R148, R151, R152, R156, R161, R170, R171, R179, R184, R191, R192, R200, R18, R42, R98, R107, R108, R168, R207, R296	4720-103A-J	RMG 1/10W 10K 1% 0805
R64, R66, R67, R69, R72, R76, R79, R81, R93, R94, R97, R101, R102, R103, R105, R127, R129, R134, R138, R144, R149, R154, R157, R223, R229, R235, R236, R238, R239, R241, R242, R249, R284,	4720-103J-J	RMG 1/10W 10K 5% 0805
R43, R114, R135, R160, R183, R193	4720-104A-J	RMG 1/10W 100K 1% 0805
R19, R29, R48, R54, R165, R185, R195, R197, R203, R204, R212, R217, R219, R220, R222, R247, R253,	4720-104J-J	RMG 1/10W 100K 5% 0805
R172	4720-151J-J	RMG 1/10W 150R 5% 0805
R95, R109, R264, R268, R282, R291, R293,	4720-220J-J	RMG 1/10W 22R 5% 0805
R276	4720-221A-J	RGM 1/10W 220R 1% 0805
R281	4720-222A-J	RMG 1/10W 2.2K 1% 0805
R182	4720-223A-J	RMG 1/10W 22K 1% 0805
R206, R209	4720-242A-J	RMG 1/10W 2.4K 1% 0805
R221	4720-271A-J	RMG 1/10W 270R 1% 0805
R164	4720-273A-J	RMG 1/10W 27K 1% 0805
R240, R243	4720-331J-J	RMG 1/10W 330R 5% 0805

ELECTRICAL PARTS LIST

Location	Part Number	Description
R278	4720-332A-J	RMG 1/10W 3.3K 1% 0805
R211	4720-392A-J	RMG 1/10W 3.9K 1% 0805
R244	4720-432J-J	RMG 1/10W 4.3K 5% 0805
R213,R216,R232,R237	4720-471A-J	RMG 1/10W 470R 1% 0805
R86,R87	4720-472A-J	RMG 1/10W 4.7K 1% 0805
R210,R246	4720-472J-J	RMG 1/10W 4.7K 5% 0805
R11,R20,R23,R25,R50,R113	4720-473A-J	RMG 1/10W 47K 1% 0805
R120,R130,R140,R147, R150,R169,	4720-474J-J	RMG 1/10W 470K 5% 0805
R2,R6,R8,R9,R12,R15-R17, R31,R32,R35,R38-R40,R49, R52,R55,R60,R62,R74,R80, R90,R99,R139,R146,R155, R162,R175,R176,R180, R181,R189,R190,R287, R295,R297,R298,R300 R274	4720-560J-J 4720-561J-J 4720-562A-J 4720-750A-J	RMG 1/10W 56R 5% 0805 RMG 1/10W 560R 5% 0805 RMG 1/10W 5.6K 1% 0805 RMG 1/10W 75R 1% 0805
R173,R177,R178		
R1,R5,R7,R10,R13,R14,R22, R24,R30,R51,R57,R59,R61, R63,R68,R71,R75,R77,R83, R84,R91,R92,R100,R104, R106,R112,R116,R126,R143, R153,R163,R167,R186,R187, R194,R196,R218, R250,R251	4720-750J-J 4721-000J-6 4721-474J-6	RMG 1/10W 75R 5% 0805 RMG 1/8W OR 5% 1206 RMG 1/8W 470K 5% 1206
L1-L21,L23-L25 D56		
<u>DIODES</u>		
D2,D4,D6,D8,D10,D12-D17,D19, D20,D23,D24,D27,D28,D31,D32, D34,D36,D37,D40,D41,D43,D44, D46,D47,D49,D51-D55,D57 D1,D3,D5,D7,D9,D11,D18,	4804-1480-3 4840-1990-3	DIODE LL4148 SM DIODE BAS70-04 DOUBLE SC

ELECTRICAL PARTS LIST

Location	Part Number	Description
D21, D22, D25, D26, D29, D30, D33, D35, D39, D38, D42, D45, D48, D50,		
<u>MISCELLANEOUS</u>		
L26-L29	1808-0680-0	FERRITE BEAD INDUCTOR
CR1, CR2, CR4	3100-5121-0	INSULATION WASHER,
RCVR1, RCVR2	4811-F32R-3	LIGHT RX UNIT GPIF32R
TRNSM1	4811-F32T-3	LIGHT TX UNIT GP1F32T

EXPLODED VIEW

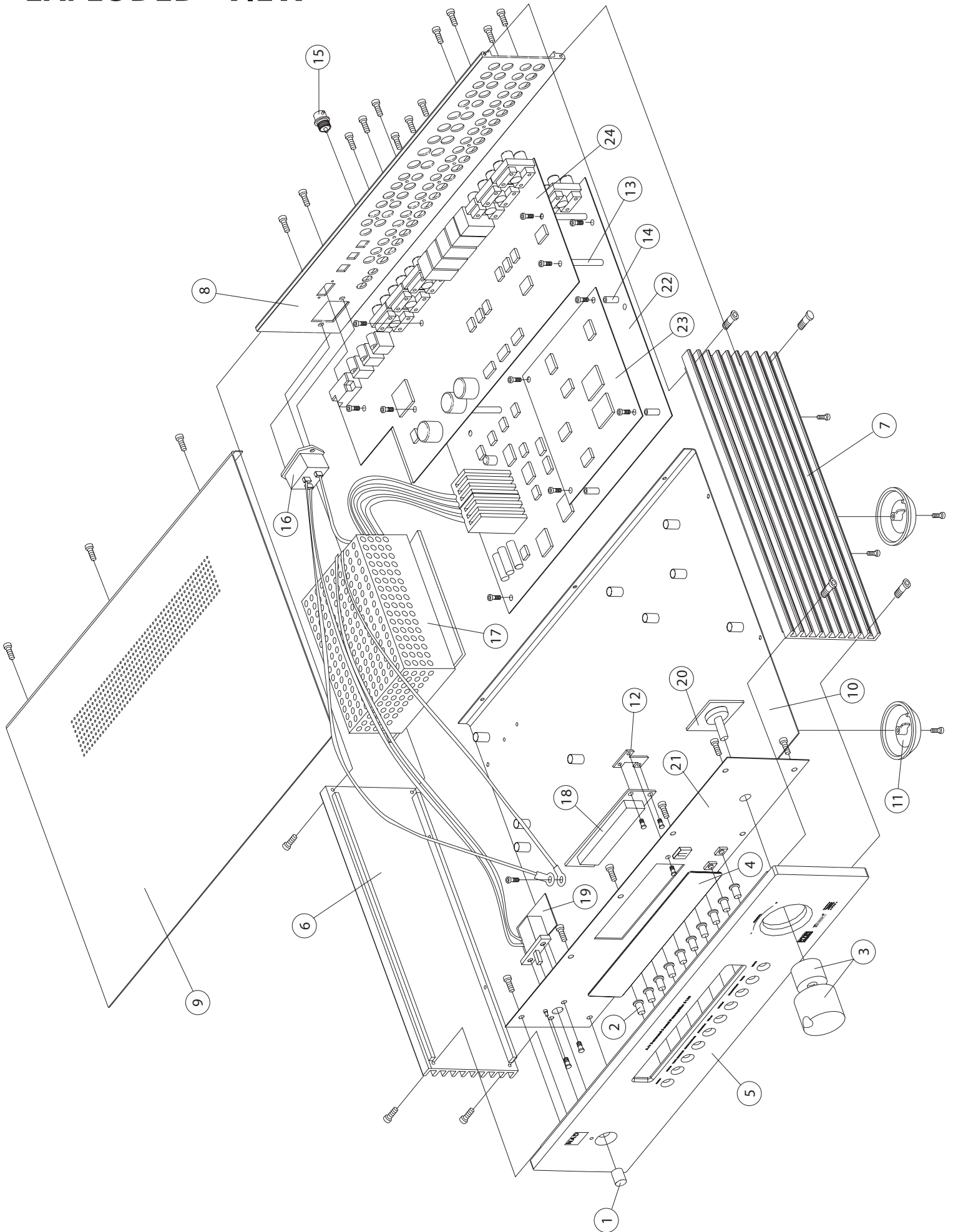



EXPLODED VIEW

LOCATION	PART NUMBER	DESCRIPTION
1	S100-2011-3	Power button 10mm
2	S100/S300-2121-1	Input button
3	S170-2032-1	Volume Knob Assembly (two parts, inner and outer-shell)
4	S170-2052-1	Display Lens
5	S170-2002-4	Aluminum Fascia
6	S170-2014-4	Left Side Panel
7	S170-2024-2	Right Side Panel
8	S170-2002-4	Rear Panel
9	S170-2004-1	Top Cover
10	S170-2034-4	Base Cover
11	S100-2013-2	Foot
12	GPE-PCB KIT	Bracket (NSP) Part of GPE-PCB KIT
13	S170-2234-2	Stand-Off A (longer stand-off)
14	S170-2334-3	Stand-OFF B (shorter stand-off)
15	GPE-PCB KIT	BNC chassis-mount for Digital Input (NSP) Part of GPE-PCB KIT
16	T40C	IEC female plug (NSP) Part of the Power Supply
17	T40C	Power Supply
18	GPE-PCB KIT	Florescent Display Part of GPE-PCB KIT
19	GPE-PCB KIT	Power Switch and PCB with cables (NSP) Part of GPE-PCB KIT
20	GPE-PCB KIT	Volume Control Module (NSP) Part of GPE-PCB KIT
21	GPE-PCB KIT	Front Panel PCB with Power Switch & PCB with cables, and Volume Control Module (NSP) Part of GPE-PCB KIT
22	GPE-PCB KIT	Main PCB with Linear Power Supply, Audio Inputs & Outputs, and Trigger Out (NSP) Part of GPE-PCB KIT
23	Gen6 A367	Gen6 A367 DSP Assembly (NSP)
24	GPE-PCB KIT	Secondary PCB with Video Inputs & Outputs, S-Video Outputs, Component Inputs & Outputs, Digital and TOSLINK Inputs & Outputs. (NSP) Part of GPE-PSB KIT
***	GPE-PCB KIT	Three Assemblies; Main, Secondary, Front Panel PCBs, not including Gen6 A367

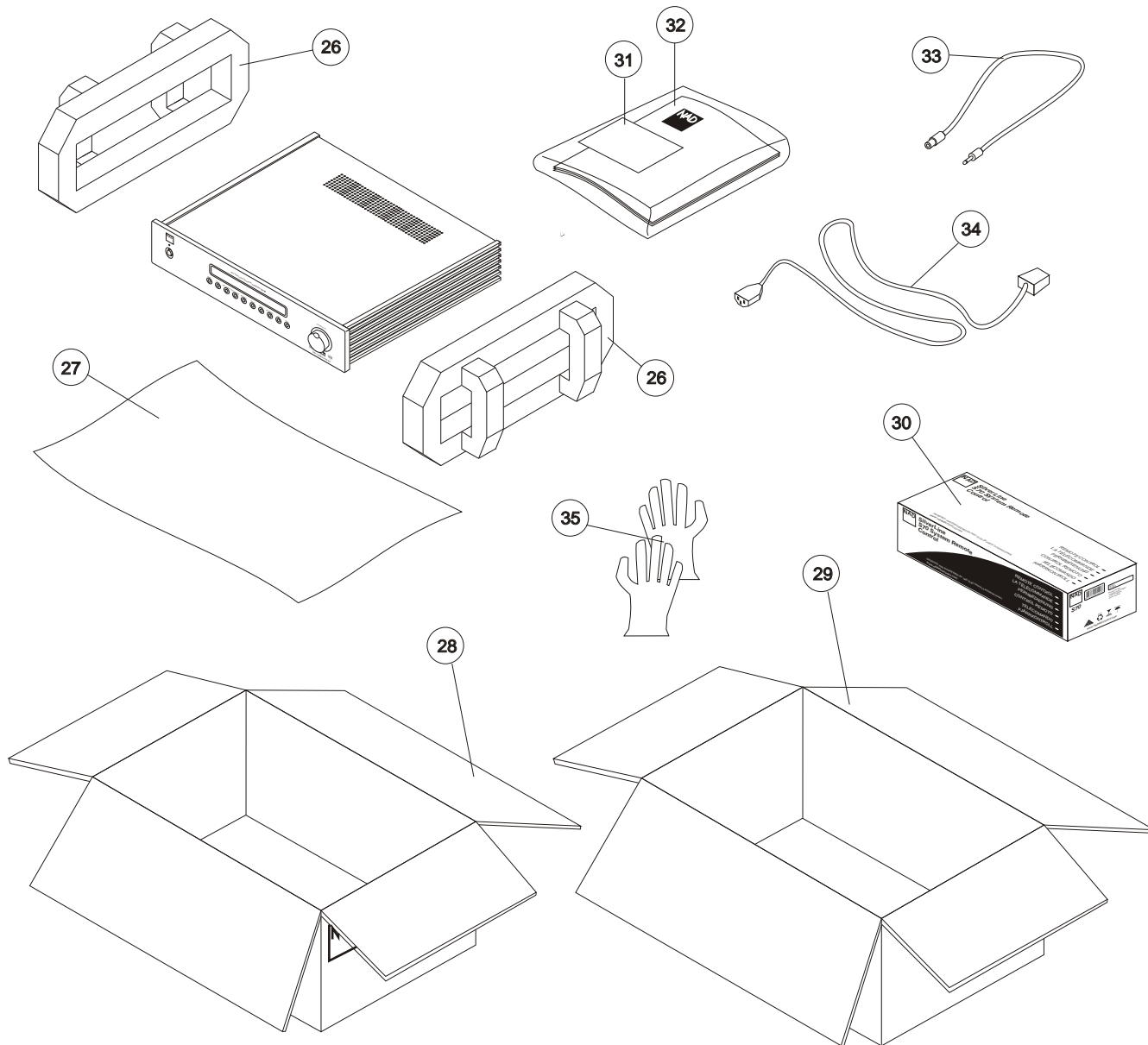
PACKING DIAGRAM



ITEM	PART NUMBER	DESCRIPTION	QTY.
26	8700.0062	CUSHION	2
27	8700.0057	WRAPPING SHEET	1
28	862004	INNER CARTON BOX	1
29	862005	OUTER CARTON BOX	1
30	S70	REMOTE CONTROL W/ BATTERY	1 SET
31	8120.0189	WARRANTY CARD	1
32	S170-IM	OWNER'S MANUAL	1
33	4150.0022	12V TRIGGER CABLE	1
34*AH 	4150.0025	POWER CORD 120V	1
34*C 	4150.0024	POWER CORD 230V	1
35	8700.0056	GLOVES	1 PAIR

NOTES

Lined area for notes, consisting of horizontal dotted lines.

SERVICE MANUAL

Copyright 2002
NAD Electronics International
633 Granite Court
Pickering, Ontario
Canada L1W 3K1

No portion of this publication may be reproduced without the written permission of NAD Electronics International. Many of the circuits and software programs described within are covered by patents and other international property laws and are used with express permission or license agreements from the owners.

Printed in Canada

S170
AV SURROUND
SOUND
PREAMPLIFIER