

SERVICE MANUAL

NAD

S250

**FIVE CHANNEL
POWER AMPLIFIER**

S250

**FIVE CHANNEL
POWER AMPLIFIER**





CONTENTS

FRONT PANEL / REAR PANEL VIEW	3
SPECIFICATIONS	4
ALIGNMENT PROCEDURE / ALIGNMENT POINTS	5
WIRING DIAGRAM	6
PCB LAYOUT	7-8
SCHEMATIC DIAGRAM	9-11
ELECTRICAL PARTS LIST	12-14
EXPLODED VIEW	15
EXPLODED VIEW PARTS LIST	16
PACKING DIAGRAM	17

SERVICE SAFETY PRECAUTIONS

1. Replacing the Fuses

CAUTION: FOR CONTINUED PROTECTION AGAINST THE RISK OF FIRE REPLACE ONLY WITH SAME TYPE OF FUSE.

REFERENCE NO.	PART NUMBER	DESCRIPTION
PSU Board		
F1*AH 	5120-0506-0	12.5A 250V Time Lag 6.3x32mm UR
F1*C 	5120-0025-0	6.3A 250V HBC Time Lag 5x20mm SEMKO/VDE
Amp Board		
F1-F2*AH 	5120-0040-0	6.3A 250V Time Lag 5x20mm UL
F1-F2*C 	5120-0025-0	6.3A 250V HBC Time Lag 5x20mm SEMKO/VDE

NOTE:

*AH : North American version only

*C : European version only

2. Safety-check out (North American model only)

Before returning the product to the customer, make leakage current or resistance measurements to determine that exposed parts are acceptably insulated from the supply circuit.

Parts marked with the symbol  are critical with regard to the risk of fire and electric shock. Replace only with parts recommended by the manufacturer.

FRONT PANEL / REAR PANEL VIEW

FRONT PANEL CONTROLS

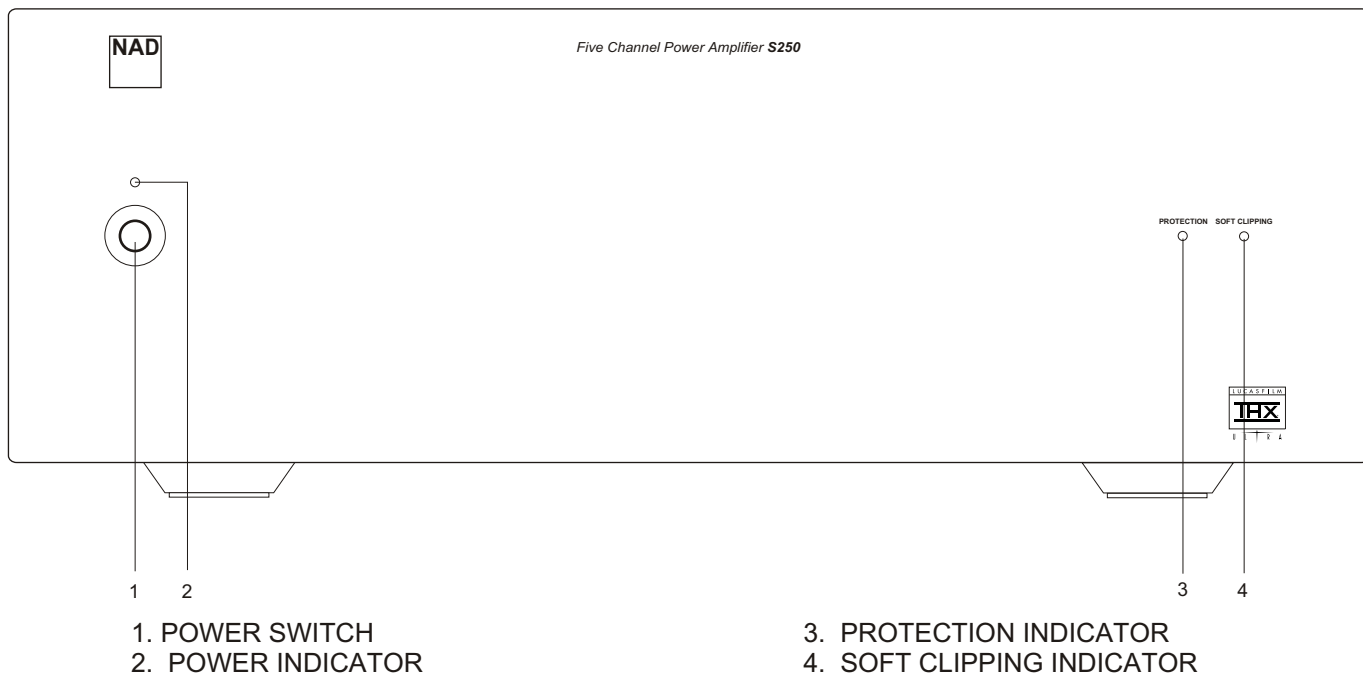

The graphic symbol of a lightning flash with an arrow point within a triangle signifies that there is dangerous voltage within the unit and it poses a hazard to anyone removing the cover to gain access to the interior of the unit. **Only qualified service personnel should make such attempt.**

The graphic symbol of an exclamation point within an equilateral triangle warns a user of the device that it is necessary to refer to the instruction manual and its warnings for proper operation of the unit.

REAR PANEL CONNECTIONS

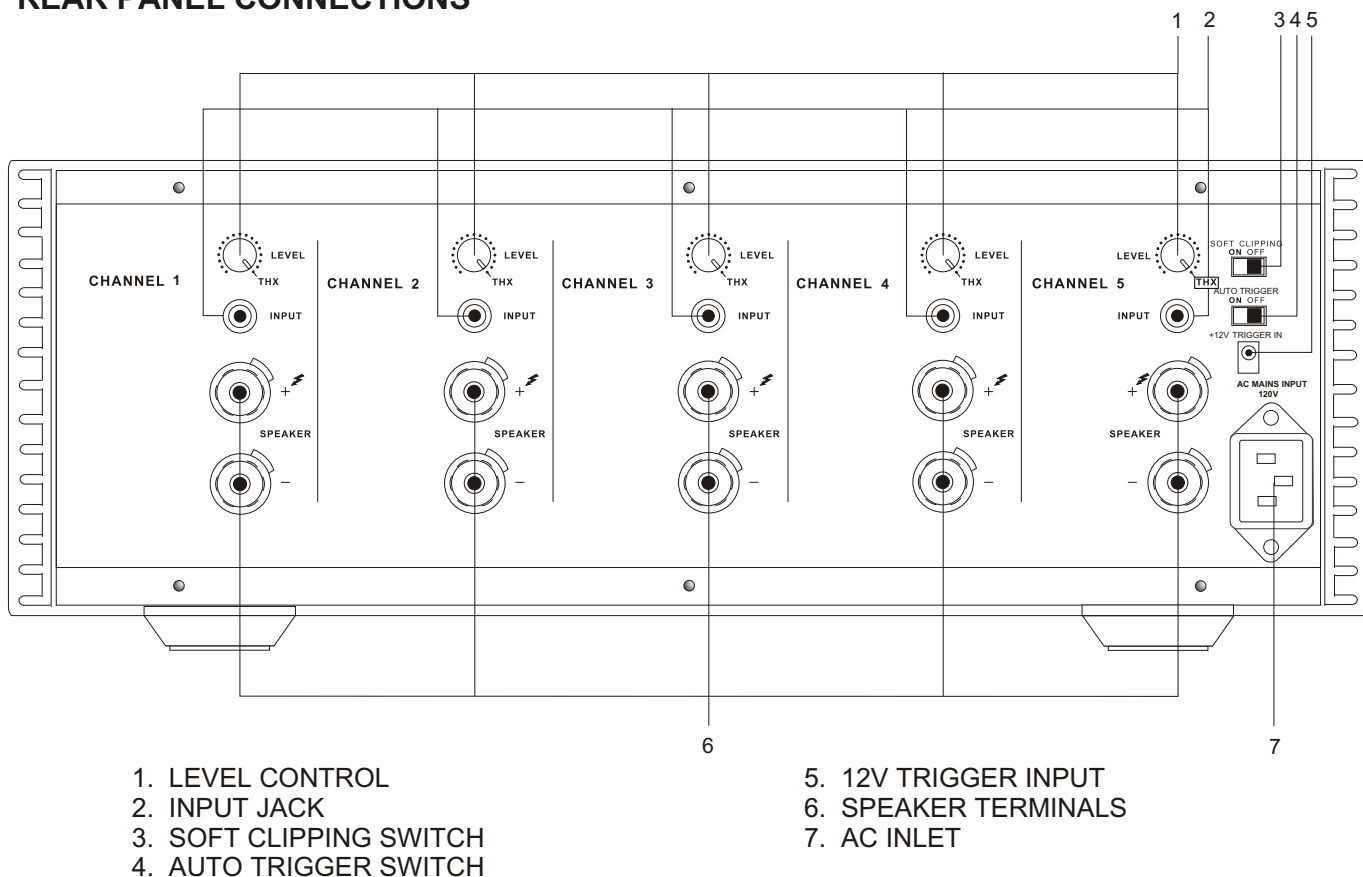

SPECIFICATIONS

Specifications are measured in accordance with IHF standard IHF-A-202, 1978.

		<u>NOMINAL</u>	<u>LIMIT</u>
1. THD		≤0.02%	≤0.03%
2. Continuous Power Output	8 ohms	≥125W	≥100W
20kHz, 5 ch. for 8 ohms, 4 ch. for 4 ohms)	4 ohms	≥125W	≥100W
3. Clipping Power		≥135W	≥110W
4. S/N Ratio	A-wtd	≥96dB	≥93dB
maximum)	Audio BPF	≥89dB	≥86dB
5. Frequency Response		0 ~ -0.1dB	0 ~ -0.25dB
6. Input Sensitivity		100 ± 2 mV	100 ± 3 mV
maximum)			
7. Channel Separation	1kHz	≥77dB	≥70dB
	20kHz	≥67dB	≥50dB
8. Soft Clipping			
Output Reduction		0.4 ~ 0.6 dB	0.3 ~ 1.0 dB
THD		5 ~ 6.5%	4 ~ 10%

ALIGNMENT PROCEDURE

IDLE CURRENT ALIGNMENT FOR EVERY POWER AMPLIFIER MODULE

1. Remove the load and the input signal.
2. Connect a digital voltmeter between TP1 and TP2.
3. Switch the amplifier on and, after one minute, adjust R27 to obtain a reading of $5\text{mV} \pm 0.5\text{mV}$.
4. Leave power on for 3 minutes to allow the idle currents to stabilize. Re-adjust R27 as necessary to obtain a reading of $4.4\text{mV} \pm 0.5\text{mV}$.

ADJUSTMENT POINTS

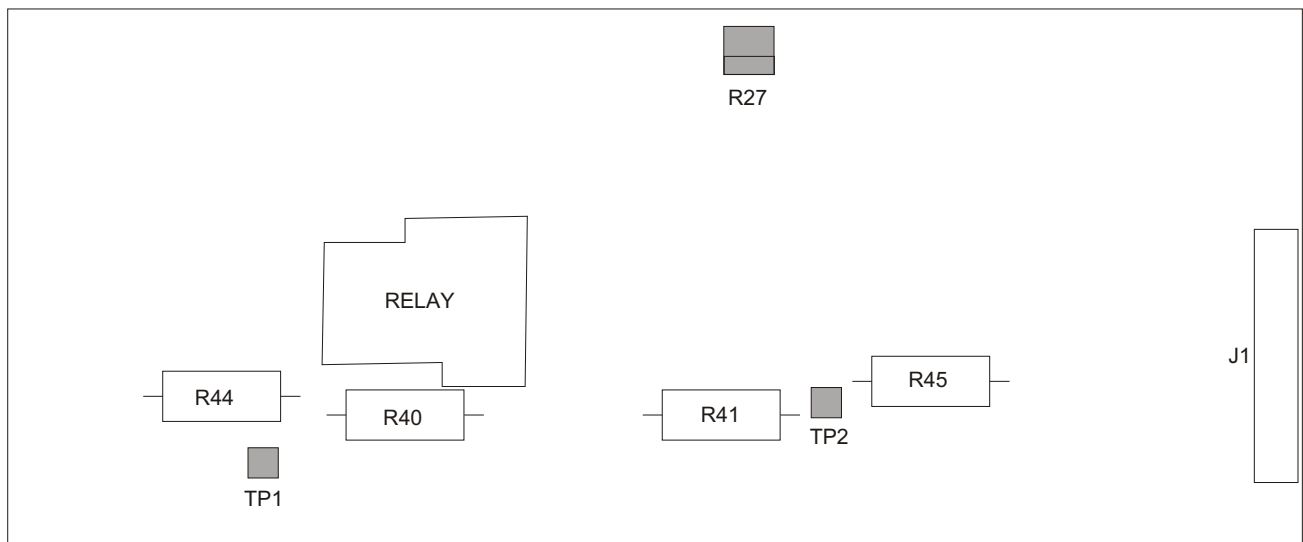

WIRING DIAGRAM

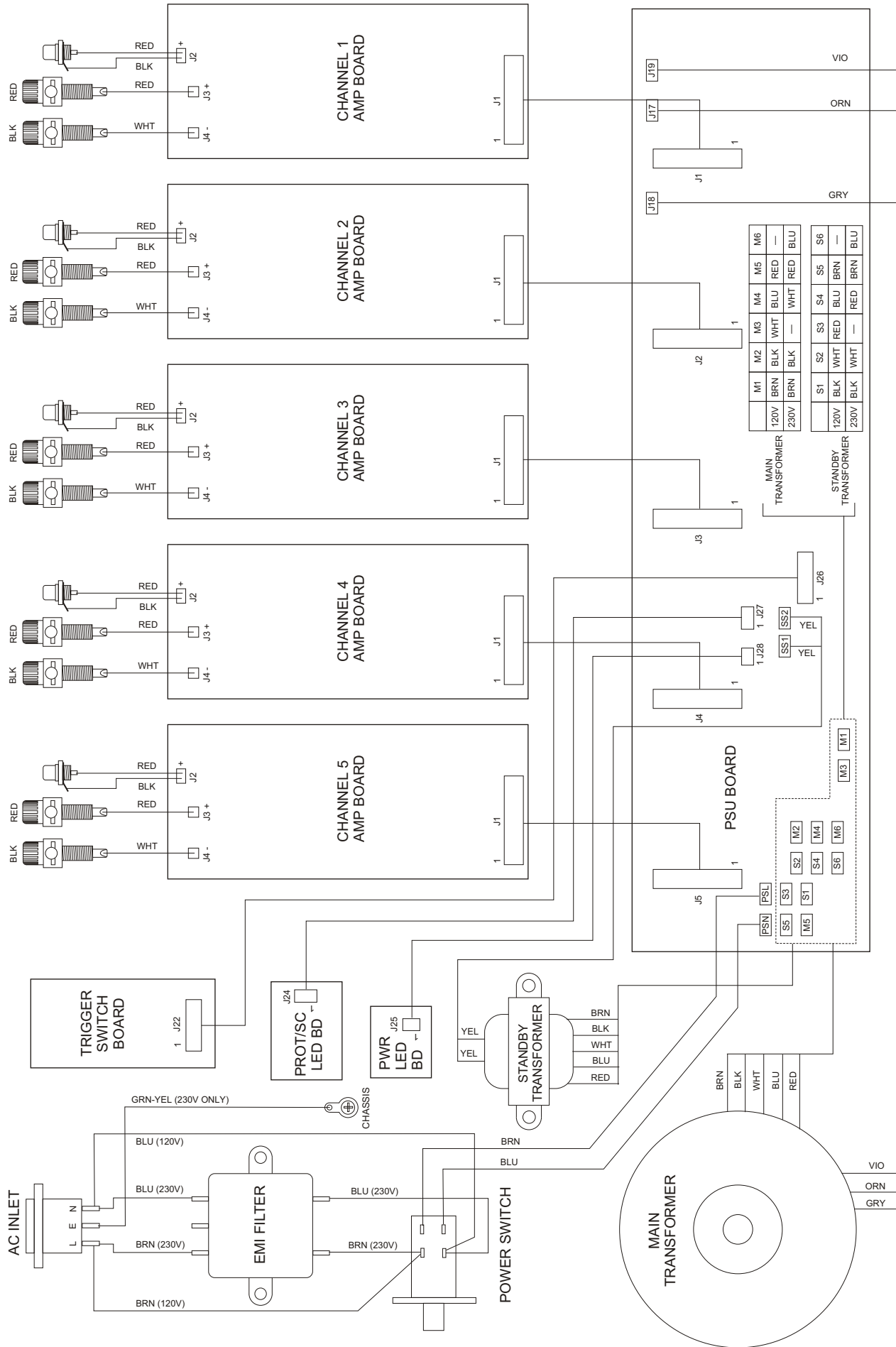

PSU BOARD - COMPONENT SIDE

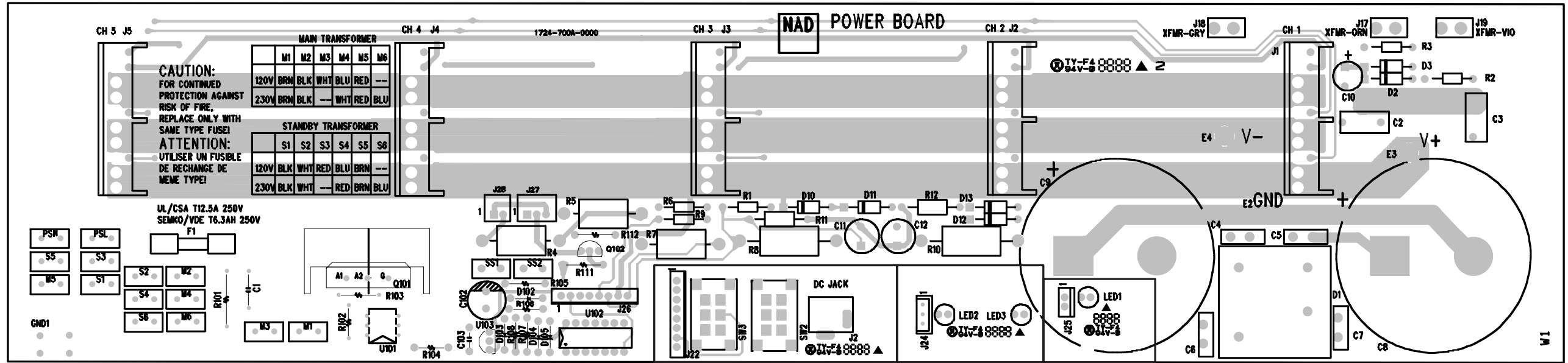

PSU BOARD - SOLDER SIDE

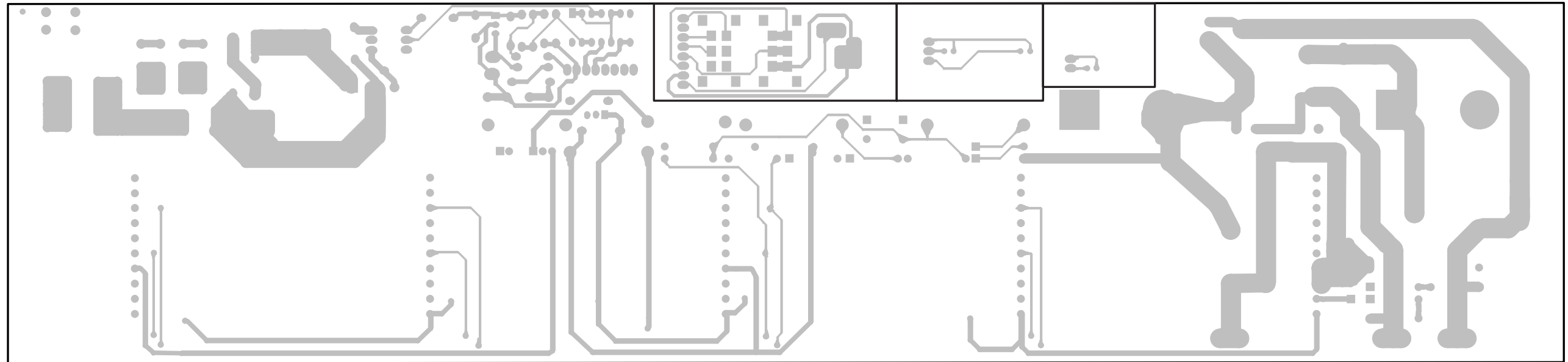

PCB LAYOUT

AMP BOARD - COMPONENT SIDE

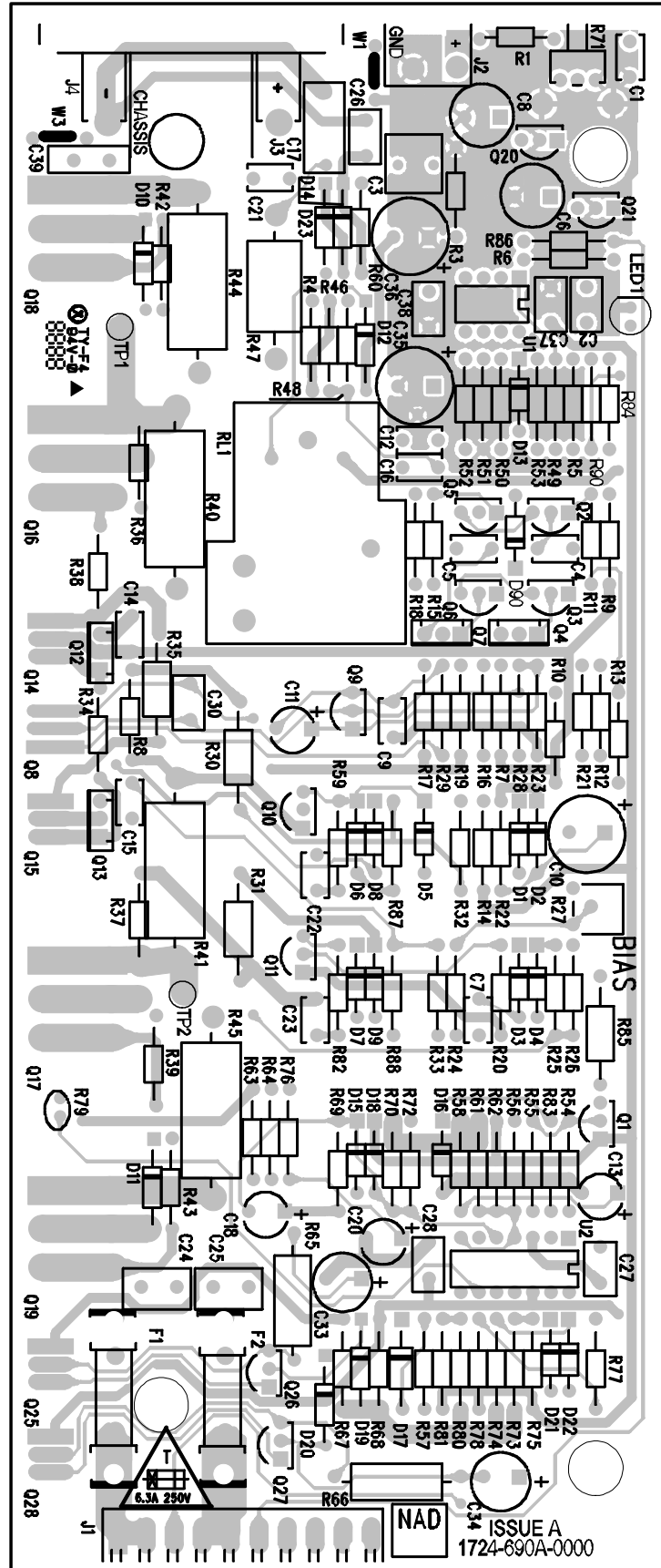

AMP BOARD - SOLDER SIDE

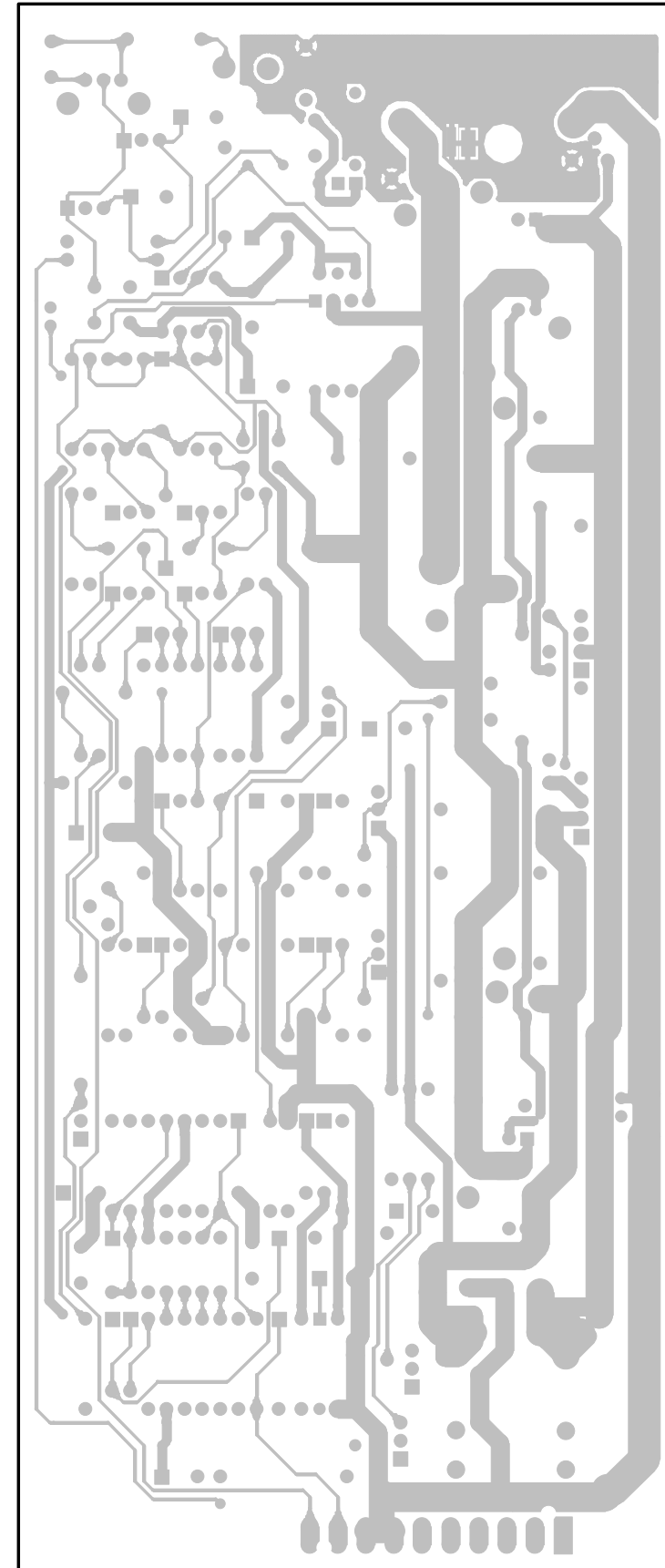

POWER SUPPLY

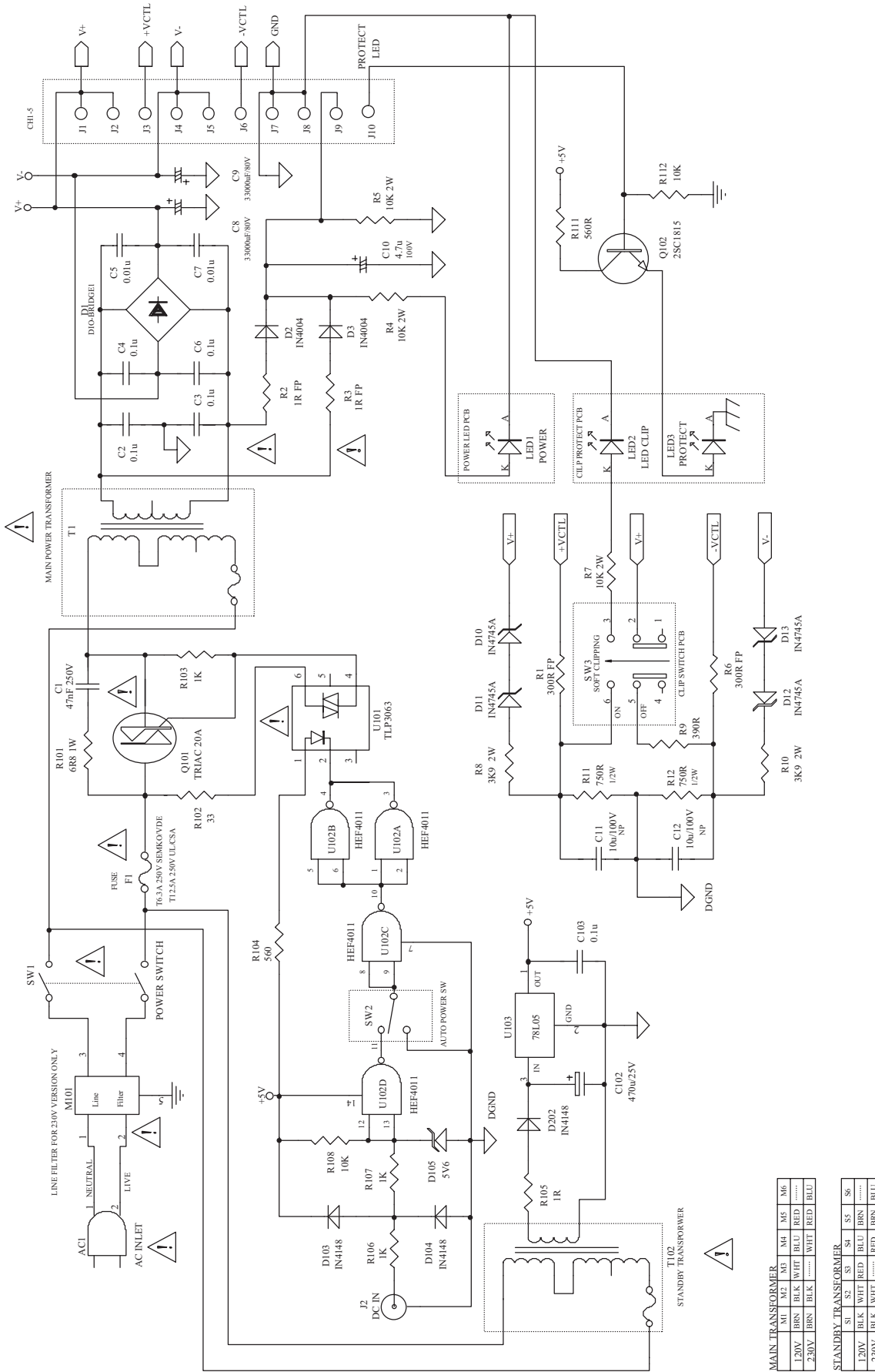

MAIN TRANSFORMER

M1	M2	M3	M4	M5	M6
120V	BRN	BLK	WHT	BLU	RED
230V	BRN	BLK	WHT	RED BLU

STANDBY TRANSFORMER

S1	S2	S3	S4	S5	S6
120V	BLK	WHT	RED	BLU	BRN
230V	BLK	WHT	RED	BRN BLU

SCHEMATIC DIAGRAM

POWER AMP 1

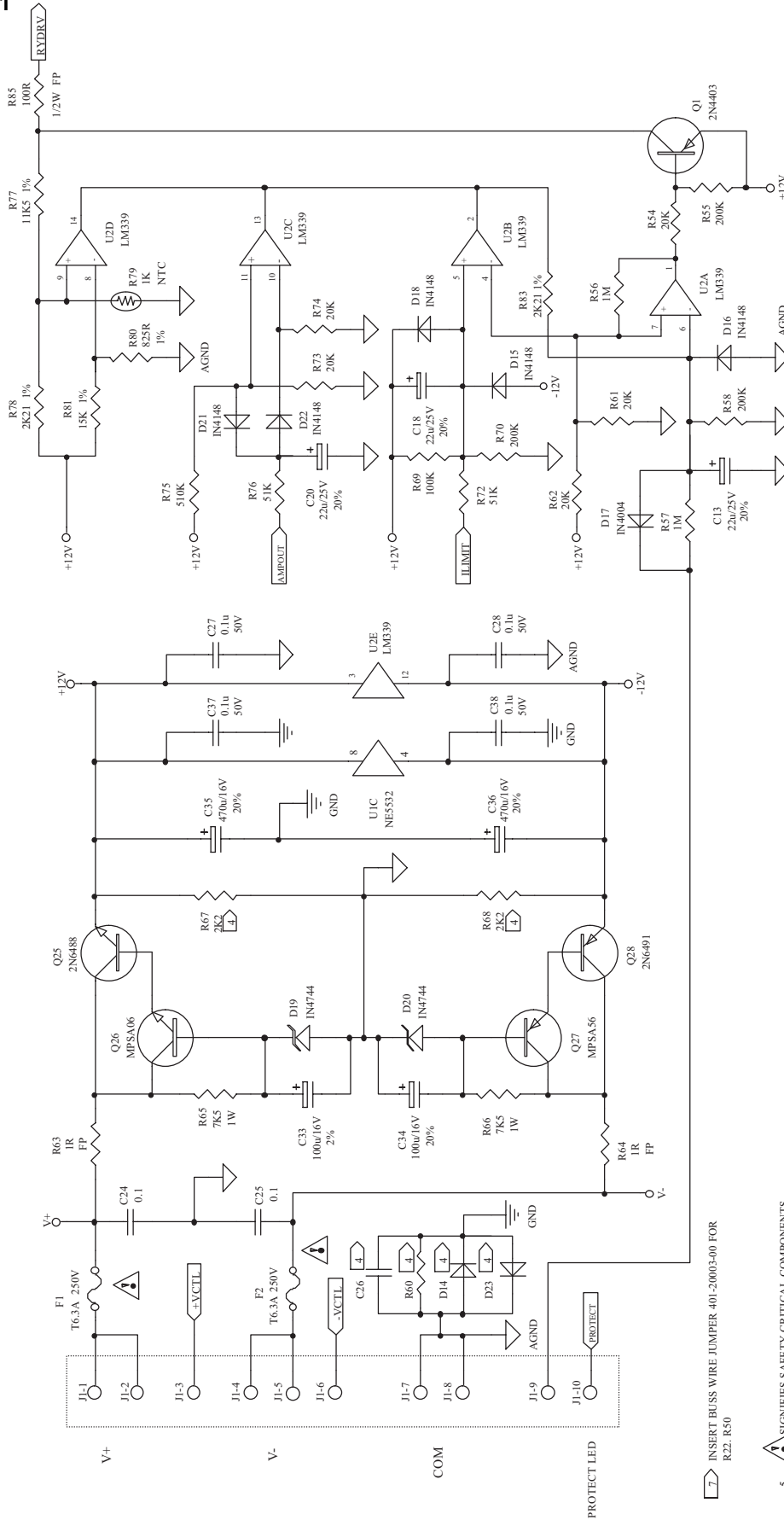

7 INSERT BUSS WIRE JUMPER 401-20003-00 FOR R22, R50

5. SIGNIFIES SAFETY CRITICAL COMPONENTS REFER TO THE SAFETY INFORMATION SECTION OF THE SERVICE MANUAL FOR COMPLETE INFORMATION. COMPONENTS NOT INSTALLED: C10, C12, C14, C15, C21, C26, D1, D2, D13, D14, D23, D24 R8, R20, R49, R52, R53, R60, R67, R68 AND R84.
3. ABBREVIATION: FLAME PROOF = FP. ALL FP DESIGNATED PARTS ARE SAFETY CRITICAL. REFER TO NOTE 5.
2. ALL CAPACTORS ARE IN MICROFARADS. 10% 100V. (DEFAULT VOLTAGE)
1. ALL RESISTORS ARE IN OHMS 1/4W 5%

POWER AMP 2

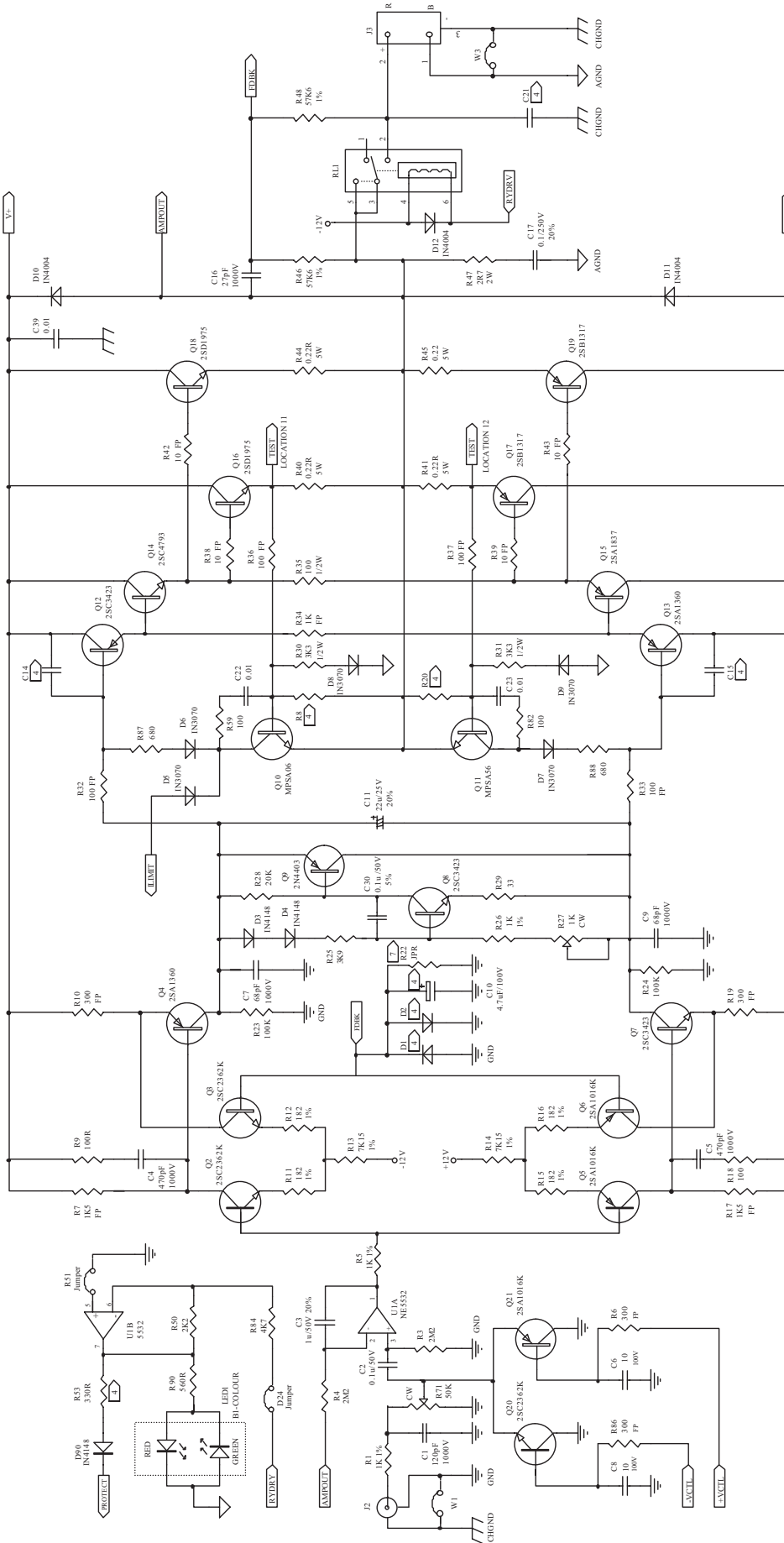

ELECTRICAL PARTS LIST

Location	Part Number	Description
POWER AMP PCB		
PCB ASSEMBLY		
1000*AH	PCB-N0920C-AMP	PCB ASSY POWER AMP
1000*C	PCB-N0921C-AMP	PCB ASSY POWER AMP
CAPACITORS		
C39	150N-103M-5-SS	CC 1KV 0.01u 20% RL
C1	150N-121K-5-II	CC 1KV 120P 10% RL 5X5
C16	150N-270K-5-II	CC 1KV 27P 10% RL 5X5
C4,C5	150N-471K-5-II	CC 1KV 470P 10% RL 5X5
C7,C9	150N-680K-5-II	CC 1KV 68P 10% RL 5X5
C3	153F-105J-5-NUN	CM 50V 1u 5% RL 7.5X11
C22,C23	153H-103J-5-MMN	CM 100V 0.01u 5% RL 7X7
C24,C25	153H-104J-5-TXN	CM 100V 0.1u 5% RL 10.5X
C2,C27,C28,C30,	153I-104J-5-NMN	CM 63V 0.1UF RL (7.5X7)
C37,C38		
C17	153R-104J-5-YRM	CM 250V 0.1u 5% RL
C35,C36	157D-477M-5-OVK	CE 16V 470UF 20% RL
C33,C34	157E-107M-5-KUK	CE 25V 100UF 20% RL
C11,C13,C18,C20	157F-226M-5-IUK	CE 50V 22uF 20% RL 5X11
C6,C8	157H-106M-5-OVH	CE 100V 10u 20% RL
IC		
U1	3130-2430-0	IC NE5532 OP AMP PHILIPS
U2	3131-3990-0	IC LM339N QUAD OP-AMP
LED		
D1	3700-4807-RG	LED RED/GREEN 5.0
RELAY		
RL1	4500-0940-0	RELAY 24VDC 30A
RESISTOR		
R63,R64	4715-010J-2-P	RMF 1/4W 1R 5% AT FP
R38,R39,R42,R43	4715-100J-2-P	RMF 1/4W 10R 5% AT FP
R32,R33,R36,R37	4715-101J-2-P	RMF 1/4W 100R 5% AT FP
R34	4715-102J-2-P	RMF 1/4W 1K 5% AT FP
R77	4715-1152-2	RMF 1/4W 11.5K 1% AT
R7,R17	4715-152J-2-P	RMF 1/4W 1.5K 5% AT FP
R11,R12,R15,R16	4715-1820-2	RMF 1/4W 182R 1% AT
R28,R54,R61,R62,	4715-203A-2	RMF 1/4W 20K 1% AT
R73,R74		
R78,R83	4715-2211-2	RMF 1/4W 2.21K 1% AT
Location	Part Number	Description
R50	4715-222A-2	RMF 1/4W 2.2K 1% AT
R3,R4	4715-225A-2	RMF 1/4W 2.2M 1% AT
R6,R10,R19,R86	4715-301J-2-P	RMF 1/4W 300R 5% AT FP
R29	4715-330A-2	RMF 1/4W 33R 1% AT
R53	4715-331A-2	RMF 1/4W 330R 1% AT
R25	4715-392A-2	RMF 1/4W 3.9K 1% AT
R84	4715-472A-2	RMF 1/4W 4.7K 1% AT
R72,R76	4715-513A-2	RMF 1/4W 51K 1% AT
R75	4715-514A-2	RMF 1/4W 510K 1% AT
R90	4715-561A-2	RMF 1/4W 560R 1% AT
R46,R48	4715-5762-2	RMF 1/4W 57.6K 1% AT
R87,R88	4715-681A-2	RMF 1/4W 680R 1% AT
R13,R14	4715-7151-2	RMF 1/4W 7.15K 1% AT
R80	4715-8250-2	RMF 1/4W 825R 1% AT
R81	4715-9531-2	RMF 1/4W 9.53K 1% AT
R35,R85	4717-101J-2-P	RMF 1/2W 100R 5% AT FP
R30,R31	4717-332A-2	RMF 1/2W 3.3K 1% AT
R65,R66	4718-752J-2-X	RMF 1W 7.5K 5% AT METAL
R47	4719-2R7J-2-X	RMF 2W 2.7R 5% AT METAL
R9,R18,R59,R82	471G-101A-2-E	RMF 0.6W 100R 1% AT
R1,R5,R21,R26	471G-102A-2-E	RMF 0.6W 1K 1% AT
R23,R24,R69	471G-104A-2-E	RMF 0.6W 100K 1% AT
R56,R57	471G-105A-2-E	RMF 0.6W 1M 1% AT
R55,R58,R70	471G-204A-2-E	RMF 0.6W 200K 1% AT
R40,R41,R44,R45	474B-R22J-1-E	RWR 5W 0.22R 5% AL AL05
DIODES		
D5-D9	4803-0700-2	DIODE BAV21 AT
D10-D12,D17	4804-0040-1	DIODE IN4004 AL
D3,D4,D15,D16,	4804-1480-2	DIODE 1N4148 AT
D18,D21,D22,D90		
D19,D20	4838-15V6-2	DZ 1W 15V AT TEMIC
TRANSISTOR		
Q1,Q9	4854-4030-5	TR 2N4403 PNP HFE100-300
Q7,Q8,Q12	4860-0790-5	TR 2SC3423 (Y) RL
Q16,Q18	4860-0880-5	TR 2SD1975 S.P RL
Q17,Q19	4860-0890-5	TR 2SB1317 S.P RL
Q15	4860-1050-5	TR 2SA1837 100-320 RL
Q14	4860-1060-5	TR 2SC4793 100-320 RL
Q25	4860-5300-5	TR 2N6488 T022B RL
Q28	4860-5310-5	TR 2N6491 T022B RL
Q4,Q13	4860-5320-5	TR 2SA1360 (Y) RL
Q5,Q6,Q21	4860-5330-5	TR 2SA1016K (G) HFE
Q2,Q3,Q20	4860-5340-5	TR 2SC2362K (G) HFE

Location	Part Number	Description
Q10,Q26	4860-8890-0	TR MPSA06 VCE 80V NS
Q11,Q27	4860-8910-0	TR MPSA56 VCE 80V NS
VR		
VR71	4750-9606-1	VR RK09K111 50KA LM=25mm
SVR27	4755-1026-3-14	SVR 1K EVM-31G 6mm DUST
FUSE		
F1,F2*AH	5120-0040-0	FU T6.3A 250V 5X20 UL
F1,F2*C	5120-0025-0	FU T6.3A HBC 5X20
MISCELLANEOUS		
J1	2101-2181-0	CENTER HEADER 3.96MM
FH1,FH2	4132-1011-0	FUSE HOLDER
TP2,TP1	4132-1071-0	TERMINAL PIN
1007	4134-9241-0	GROUND TERMINAL
R79	8910-0491-0	NTC THERMISTOR 1K (B)
POWER SUPPLY PCB		
PCB ASSEMBLY		
1100*AH	PCB-N0920C-PSU	PCB ASSY POWER SUPPLY
1100*C	PCB-N0921C-PSU	PCB ASSY POWER SUPPLY
CAPACITORS		
C103	150F-104K-5-II	CC 50V 0.1uF 10% RL 5x5
C4-C7	150N-103M-5-SS	CC 1KV 0.01u 20% RL
C2,C3	153R-104J-5-YRM	CM 250V 0.1u 5% RL
C102	157E-477M-5-SXK	CE 25V 470UF 20% RL
C11,C12	157H-106M-5-OVH	CE 100V 10u 20% RL
C10	157H-475M-5-IUC	CE 100V 4.7UF 20% RL
C1	8910-0049-0	CAP400V 4700P
C8,C9	8910-0490-0	CE 80V 33000uF 20%
DIODES		
D102	4804-0010-2	DIODE 1N4001 A1
D2,D3	4804-0040-1	DIODE IN4004 AL
D103,D104	4804-1480-2	DIODE 1N4148 AT
D105	4837-5B61-2	DZ 1/2W 5.45-5.73 ROHM
D10-D13	4838-16V6-2	DZ 1W 16V AT TEMIC
D1	4840-7100-0	BRIDGE RECTIFIER MP2540W
TRANSFORMER		
T102	1806-3520-0	TRANS EI35 115/230V DC
Location	Part Number	Description
TERMINAL		
0103	2113-1144-0	AC INLET
J17-J19,M1-M6,PSL,PSN,S1-S6,SS1,SS2,J1-J5	2101-2171-0	PCB CONN.(CENTER 3.96MM
J28	2102-021S-004	2P ST.WAFER
J27	2102-031S-004	3 PIN ST. WAFER
J26	2102-081S-004	WAFER 8P P2.5 ST.
IC		
U103	3130-0640-0	IC NJM78L05A 826
U101	3131-6720-0	IC TLP3063 PHOTO TRIAC
U102	3131-6730-0	IC HFE 4011BP QUADRUPLE
RESISTOR		
R105	4715-010A-2	RMF 1/4W 1R 1% AT
R2,R3	4715-100J-2-P	RMF 1/4W 10R 5% AT FP
R103,R106,R107	4715-102A-2	RMF 1/4W 1K 1% AT
R108,R112	4715-103A-2	RMF 1/4W 10K 1% AT
R1,R6	4715-301J-2-P	RMF 1/4W 300R 5% AT FP
R102	4715-330A-2	RMF 1/4W 33R 1% AT
R9	4715-391A-2	RMF 1/4W 390R 1% AT
R104,R111	4715-561A-2	RMF 1/4W 560R 1% AT
R101	4718-6R8J-1-X	RMF 1W 6.8R 5% AL METAL
R4,R5,R7	4719-103J-1-X	RMF 2W 10K 5% AL METAL
R8,R10	4719-392J-1-X	RMF 2W 3.9K 5% AL METAL
R11,R12	471G-751A-2-E	RMF 0.6W 750R 1% AT
TRANSISTOR/TRIAC		
Q102	4860-0700-5	TR 2SC1815 (G.R) RL
Q101	4860-5350-5	TR BTA26A-600B RL
FUSE		
F1*C	5120-0025-0	FU T6.3A HBC 5X20
F1*AH	5120-0506-0	FUSE T12.5A 250V UR
HEATSINKS		
1101	5400-9071-0	HEAT SINK
1102	5400-9081-0	HEATSINK FOR BRIDGE
MISCELLANEOUS		
0116	5200-3441-0	POWER SWITCH DPST
1108	1660-0700-0	INSULATING BOOT (ID=14)
FL1*C	1806-3519-0	EMI FILTER 20DBAG5
1109	3100-5491-0	INSULATION SHEET 112X27
FH1*AH	4131-9131-0	FUSE HOLDER 6.5MM PITCH





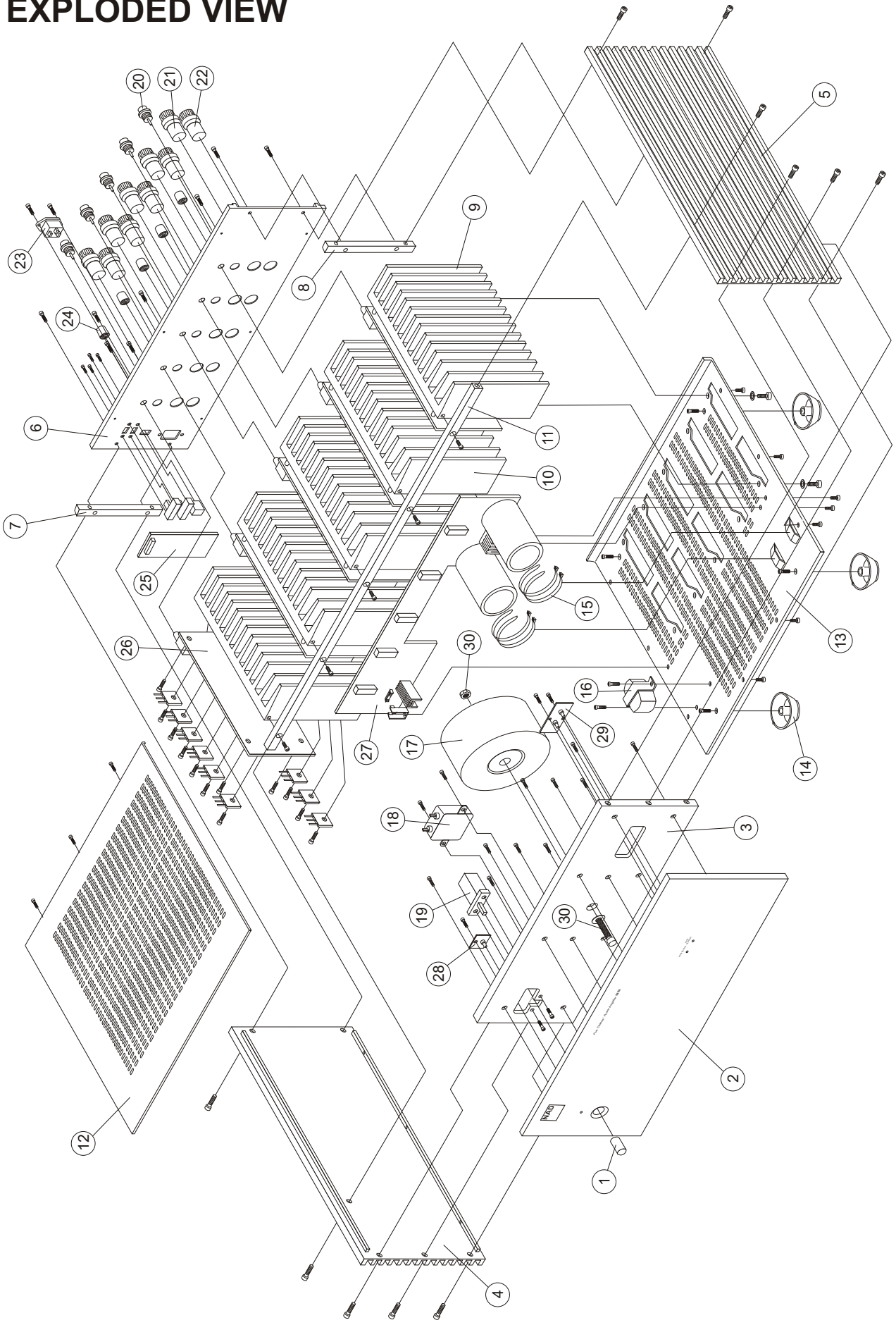

Location	Part Number	Description
FH1*C GND1	4132-1011-0 4132-6221-0	FUSE HOLDER BRACKET, GROUNDING
TRIGGER SW PCB <u>PCB ASSEMBLY</u> 1200	PCB-N0920C-SW	PCB ASSY TRIGGER SWITCH
<u>WAFERS/JACKS</u> J2 J22	2101-2191-0 2102-081R-004	DC JACK 3.5 8 PIN RIGHT ANGLE WAFER
<u>RESISTOR</u> J2C	4715-472A-2	RMF 1/4W 4.7K 1% AT
<u>SWITCH</u> SW02,SW03	5200-3251-0-01	SLIDE SW DPDT VERT 4MM
PROTECT LED PCB <u>PCB ASSEMBLY</u> 1300	PCB-N0920C-LED	PCB ASSY PROTECT LED
<u>WAFER</u> J24	2102-031R-004	WAFER 3P P2.5 RIGHT
<u>LED</u> LED3 LED2	3700-3538-B 3700-3607-R	LED 3MM FLAT TOP BLUE LED RED 3MM DIA
POWER LED PCB <u>PCB ASSEMBLY</u> 1400	PCB-N0920C-PSW	PCB ASSY POWER LED
<u>WAFERS</u> J25	2102-021R-004	WAFER 2P P2.5 RIGHT
<u>LED</u> LED1	3700-3538-B	LED 3MM FLAT TOP BLUE

Parts marked with the symbol ⚠ are critical with regard to the risk of fire and electric shock. Replace only with parts recommended by

EXPLODED VIEW





EXPLODED VIEW PARTS LIST

Location	Part Number	Description	Quantity
1	S100-2011-3	POWER BUTTON	1
2	S250-2002-1	FRONT PANEL	1
3	S250-2003-3	SUBFASCIA	1
4	S250-2014-3	LEFT SIDE PANEL	1
5	S250-2024-3	RIGHT SIDE PANEL	1
6*AH	S250-2006-2	REAR PANEL 120V	1
6*C	S250-2006-2	REAR PANEL 230V	1
7	S250-2057-1	REAR PANEL BAR B	1
8	S250-2047-1	REAR PANEL BAR A	1
9	S250-2027-4	HEATSINK B	1
10	S250-2017-4	HEATSINK A	4
11	S250-2037-2	HEATSINK BAR	1
12	S250-2005-2	TOP COVER	1
13	S250-2034-1	BASE PLATE	1
14	S100-2013-2	DIECAST FOOT	4
15	5600.0005	TIE-WRAP	4
16	 1806-3520-0	STANDBY TRANSFORMER	1
17	 4554.0052	POWER TRANSFORMER	1
18*C	 1806-3519-0	EMI FILTER 20DBAG5	1
19	 5200-3441-0	POWER SWITCH	1
20	 2113-1206-0	RCA JACK	5
21	4208.001	SPEAKER TERMINAL BLACK	5
22	4208.0009	SPEAKER TERMINAL RED	5
23	 2113-1144-0	AC INLET	1
24	4152-4621-0	LEVEL KNOB	5
25	PCB-N0920C-SW	12V TRIGGER PCB	1
26*AH	PCB-N0920C-AMP	POWER AMP PCB 120V	1
26*C	PCB-N0921C-AMP	POWER AMP PCB 230V	1
27*AH	PCB-N0920C-PSU	PSU PCB 120V	1
27*C	PCB-N0921C-PSU	PSU PCB 230V	1
28	PCB-N0920C-PSW	POWER LED PCB	1
29	PCB-N0920C-LED	PROTECT LED PCB	1
30	5180.0004	TRANSFORMER BOLT/NUT	1

Parts marked with the symbol  are critical with regard to the risk of fire and electric shock. Replace only with parts recommended by the manufacturer.

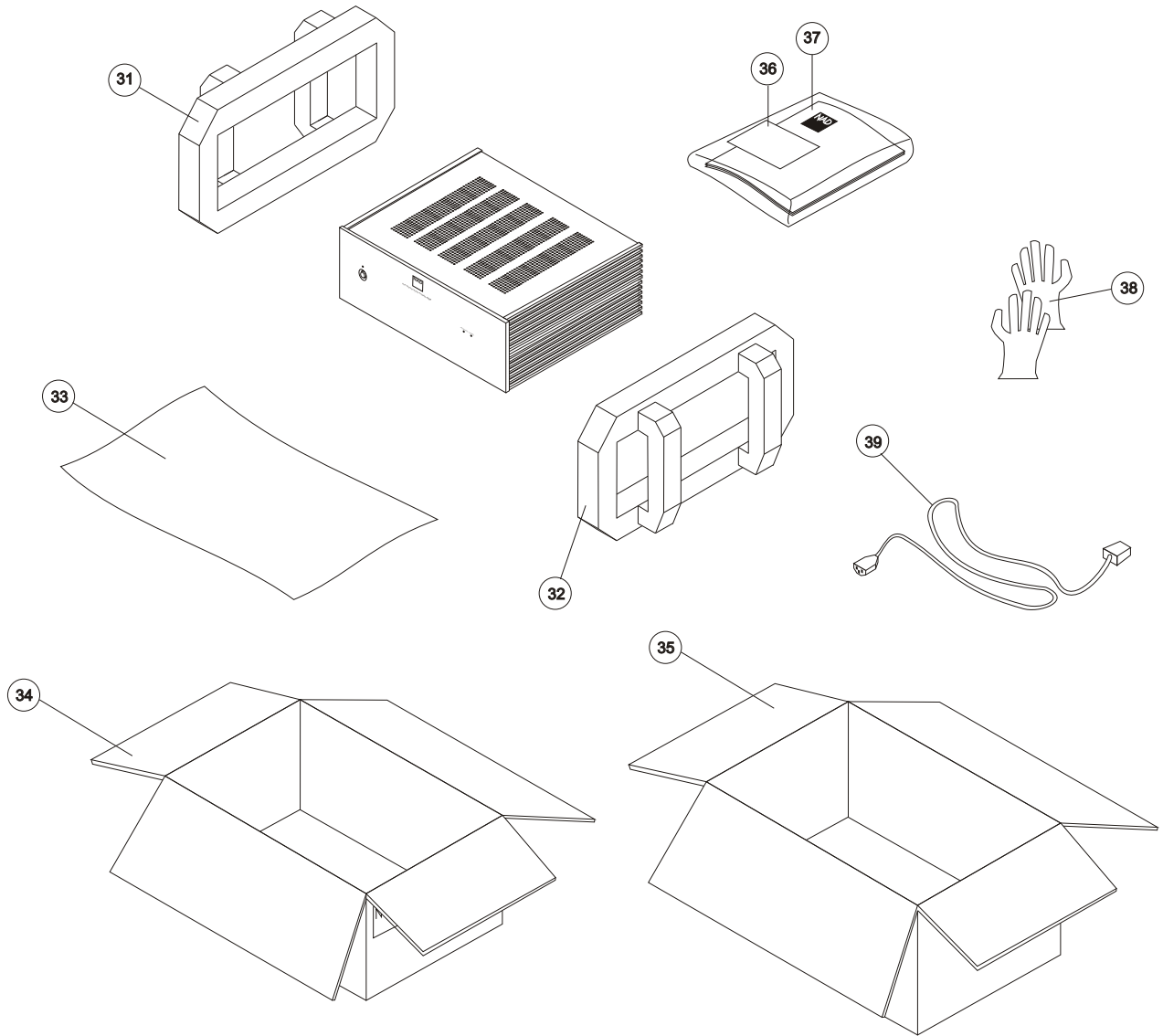
PACKING DIAGRAM



REF. NO.	PART NUMBER	DESCRIPTION	QTY.
31	8700.0058	LEFT CUSHION	1
32	8700.0059	RIGHT CUSHION	1
33	8700.0057	WRAPPING SHEET	1
34	860129	INNER CARTON BOX	1
35	860135	OUTER CARTON BOX	1
36	8120.0189	WARRANTY CARD	1
37	8100.0174A	OWNER'S MANUAL	1
38	8700.0056	GLOVES	1 PAIR
39*AH 	4150.0009	POWER CORD 120V	1
39*C 	4150.0011	POWER CORD 230V	1

SERVICE MANUAL

Copyright 2003
NAD Electronics International
633 Granite Court
Pickering, Ontario
Canada L1W 3K1

No portion of this publication may be reproduced without the written permission of NAD Electronics International. Many of the circuits and software programs described within are covered by patents and other international property laws and are used with express permission or license agreements from the owners.

Printed in Canada

S250
FIVE CHANNEL
POWER AMPLIFIER