

S 300 SERVICE MANUAL

CONTENTS

FRONT PANEL / REAR PANEL VIEW	3
SPECIFICATIONS	4
ALIGNMENT PROCEDURE / ALIGNMENT POINTS	5
WIRING DIAGRAM	6
PCB LAYOUT	7-12
SCHEMATIC DIAGRAM	13-21
IC BLOCK DIAGRAM	22
ELECTRICAL PARTS LIST	23-28
EXPLODED VIEW	29
EXPLODED VIEW PARTS LIST	30
PACKING DIAGRAM	31

SERVICE SAFETY PRECAUTIONS

1. Replacing the Fuses

CAUTION: FOR CONTINUED PROTECTION AGAINST THE RISK OF FIRE REPLACE ONLY WITH SAME TYPE OF FUSE.

REFERENCE NO.	PART NUMBER	DESCRIPTION
F1*AH	5100-2510-1C	Fuse 250mA 250V Time Lag UL/CSA
F2*AH	5120-0061-0	Fuse 12A 250V Time Lag 6.3x32mm UL/CSA
F1*C	5120-0035-0	Fuse 100mA 250V Time Lag LBC VDE/SEMKO
F2*C	5120-0025-0	Fuse 6.3A 250V Time Lag HBC VDE/SEMKO

NOTE:

*AH : North American model only

*C : European model only

2. Safety-check out (North American model only)

Parts marked with the symbol  are critical with regard to the risk of fire and electric shock. Replace only with parts recommended by the manufacturer.

Before returning the product to the customer, make leakage current or resistance measurements to determine that exposed parts are acceptably insulated from the supply circuit.

FRONT PANEL / REAR PANEL VIEW

FRONT PANEL CONTROLS

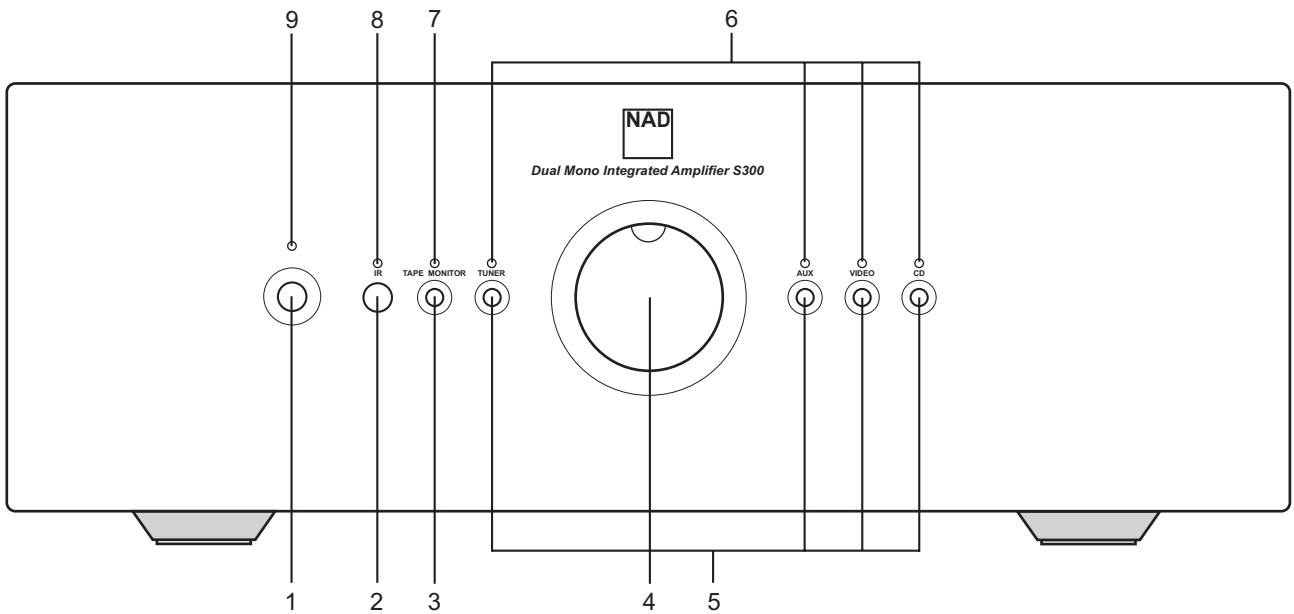

- | | | |
|-----------------------|--------------------|---------------------------|
| 1. POWER SWITCH | 4. VOLUME CONTROL | 7. TAPE MONITOR INDICATOR |
| 2. INFRA-RED RECEIVER | 5. INPUT SELECTOR | 8. INFRA-RED INDICATOR |
| 3. TAPE MONITOR | 6. INPUT INDICATOR | 9. POWER INDICATOR |

 The graphic symbol of a lightning flash with an arrow point within a triangle signifies that there is dangerous voltage within the unit and it poses a hazard to anyone removing the cover to gain access to the interior of the unit. **Only qualified service personnel should make such attempt.**

 The graphic symbol of an exclamation point within an equilateral triangle warns a user of the device that it is necessary to refer to the instruction manual and its warnings for proper operation of the unit.

REAR PANEL CONNECTIONS

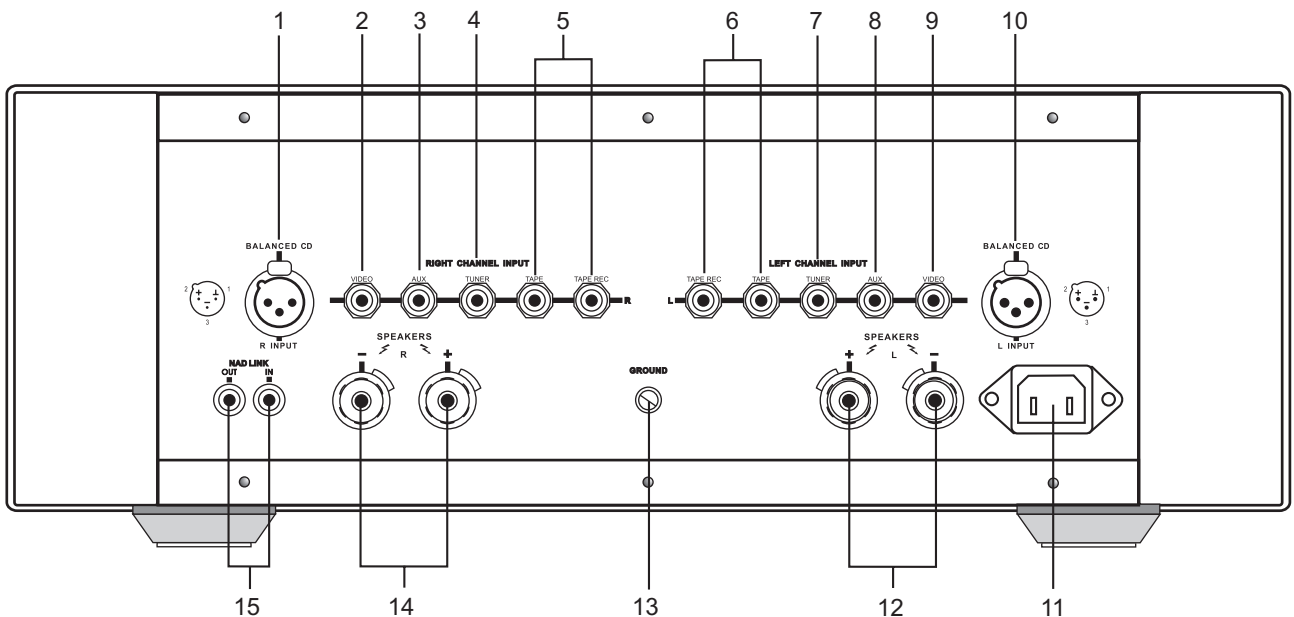

- | | | |
|----------------------------|----------------------------|---------------------------|
| 1. RIGHT BALANCED CD INPUT | 6. LEFT TAPE INPUT/OUTPUT | 11. AC INLET |
| 2. RIGHT VIDEO INPUT | 7. LEFT TUNER INPUT | 12. LEFT SPEAKER OUTPUT |
| 3. RIGHT AUX INPUT | 8. LEFT AUX INPUT | 13. GROUND TERMINAL |
| 4. RIGHT TUNER INPUT | 9. LEFT VIDEO INPUT | 14. RIGHT SPEAKER OUTPUT |
| 5. RIGHT TAPE INPUT/OUTPUT | 10. LEFT BALANCED CD INPUT | 15. NAD LINK INPUT/OUTPUT |

SPECIFICATIONS

Measured in accordance with EIA Standard RS-490 (IHF-A-202) 1978.

Continuous average power output at 8Ω (Minimum power per channel, 20Hz-20kHz, both channels driven, with no more than rated distortion)		100W (20dBW)
Input impedance	Single ended Balanced	10KΩ 20KΩ
Sensitivity (for rated power into 8Ω)		350mV
Signal-to-Noise ratio (A-weighted)	ref. 1W	88dB
Frequency response	20Hz - 20kHz -3dB	+/-0.1dB DC - 250kHz
Gain tracking error		+/-0.1 at maximum +/-3dB at -60dB level
Damping factor (ref. 8Ω, 50 Hz)		>110

Physical specifications

Dimensions (W x H x D)	450 x 160 x 400 mm
Net weight	25.5 kg / 56.1 lbs

ALIGNMENT PROCEDURE

IDLE CURRENT ALIGNMENT (no load, no signal)

1. Connect a digital millivoltmeter between TP301 and TP303, and adjust P501 to obtain a reading of between 30mV and 35mV.
2. Transfer the digital millivoltmeter to TP302 and TP304 and adjust P502 to obtain a reading of between 30mV and 35mV.
3. Leave power on for at least 5 minutes to allow the idle currents to stabilize.
Re-adjust P501 and P502 as necessary to obtain a reading of between 30mV to 35mV on each channel.

ADJUSTMENT POINTS

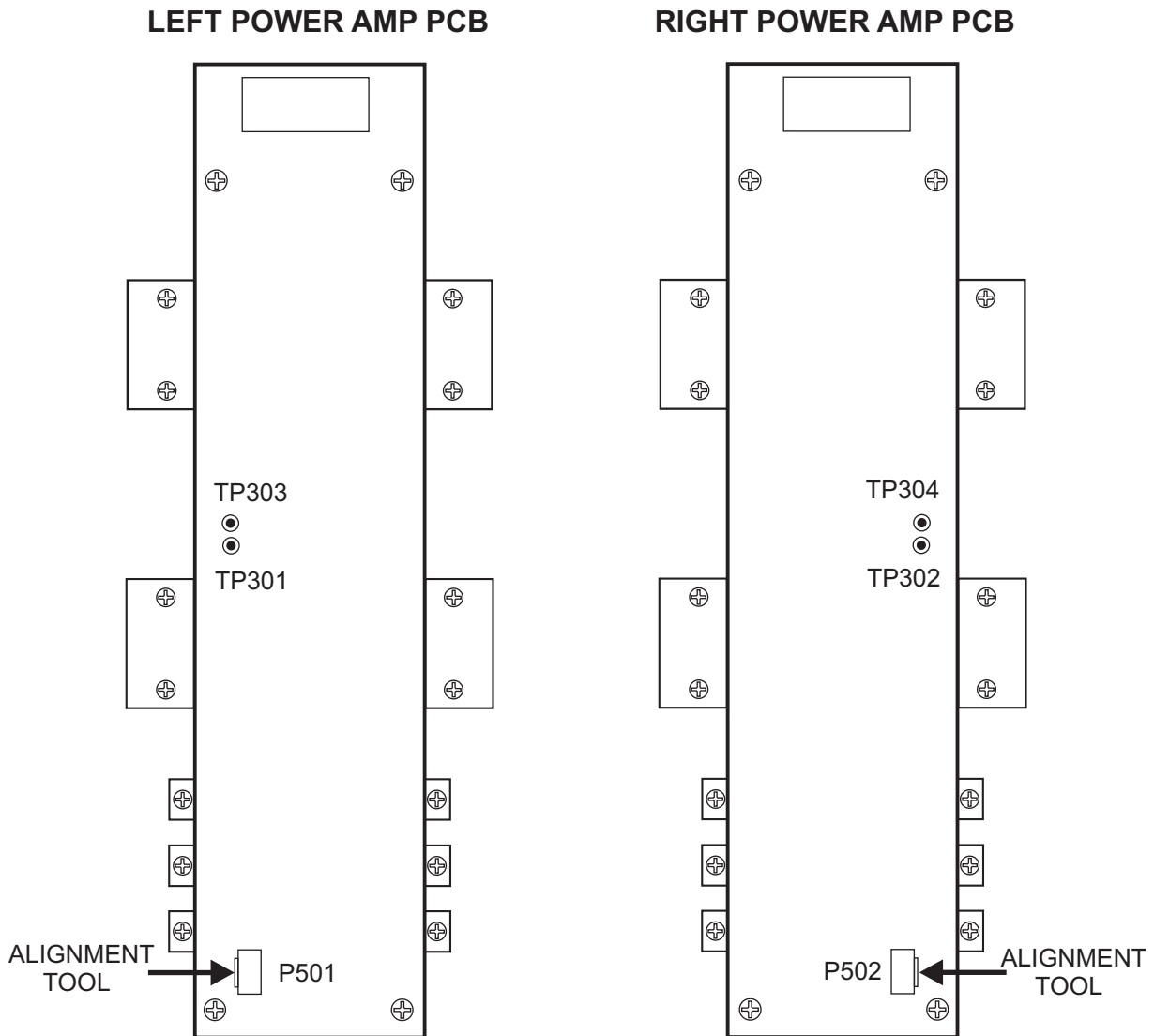

WIRING DIAGRAM

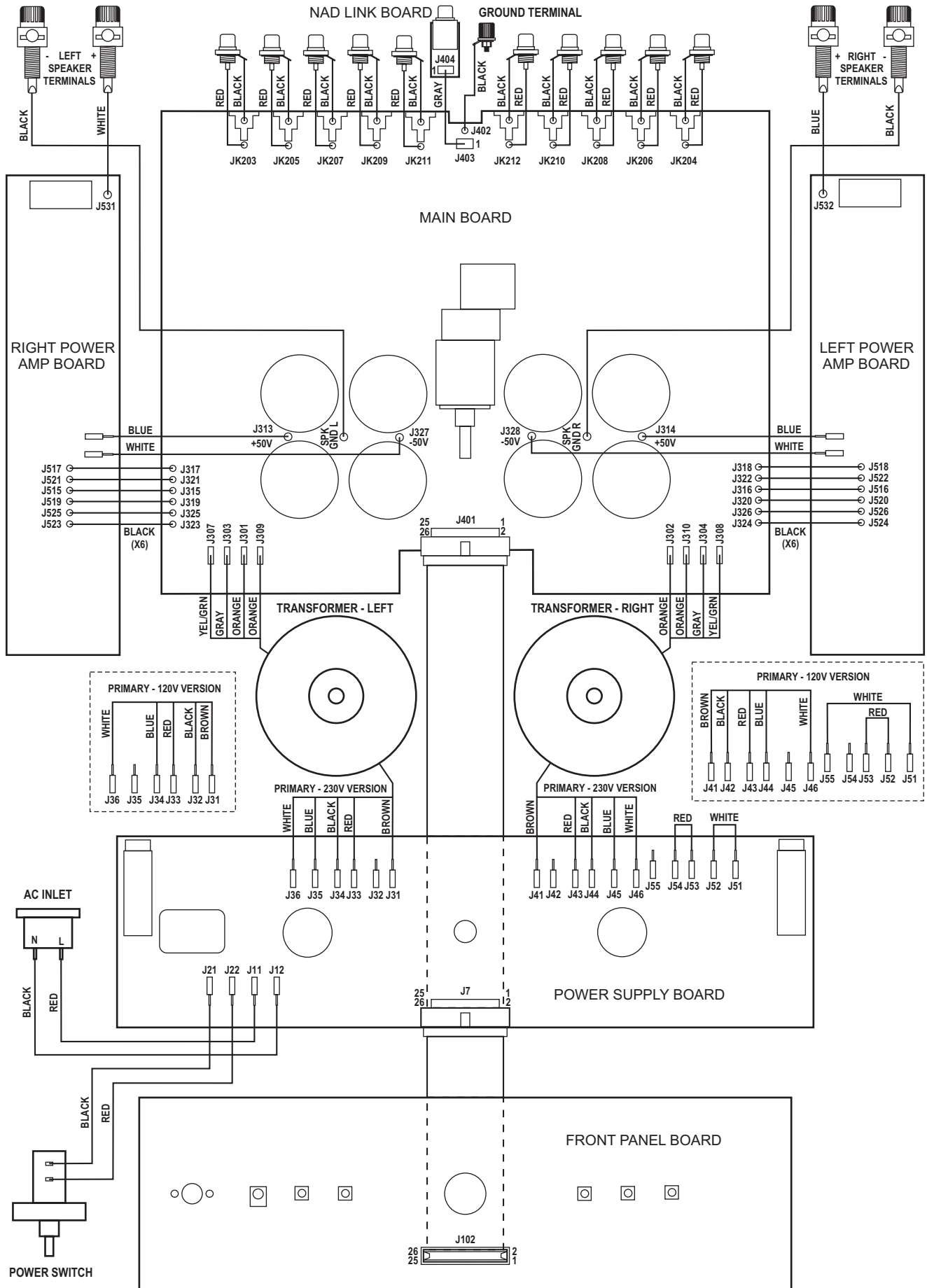

SCHEMATIC DIAGRAM PSU BOARD

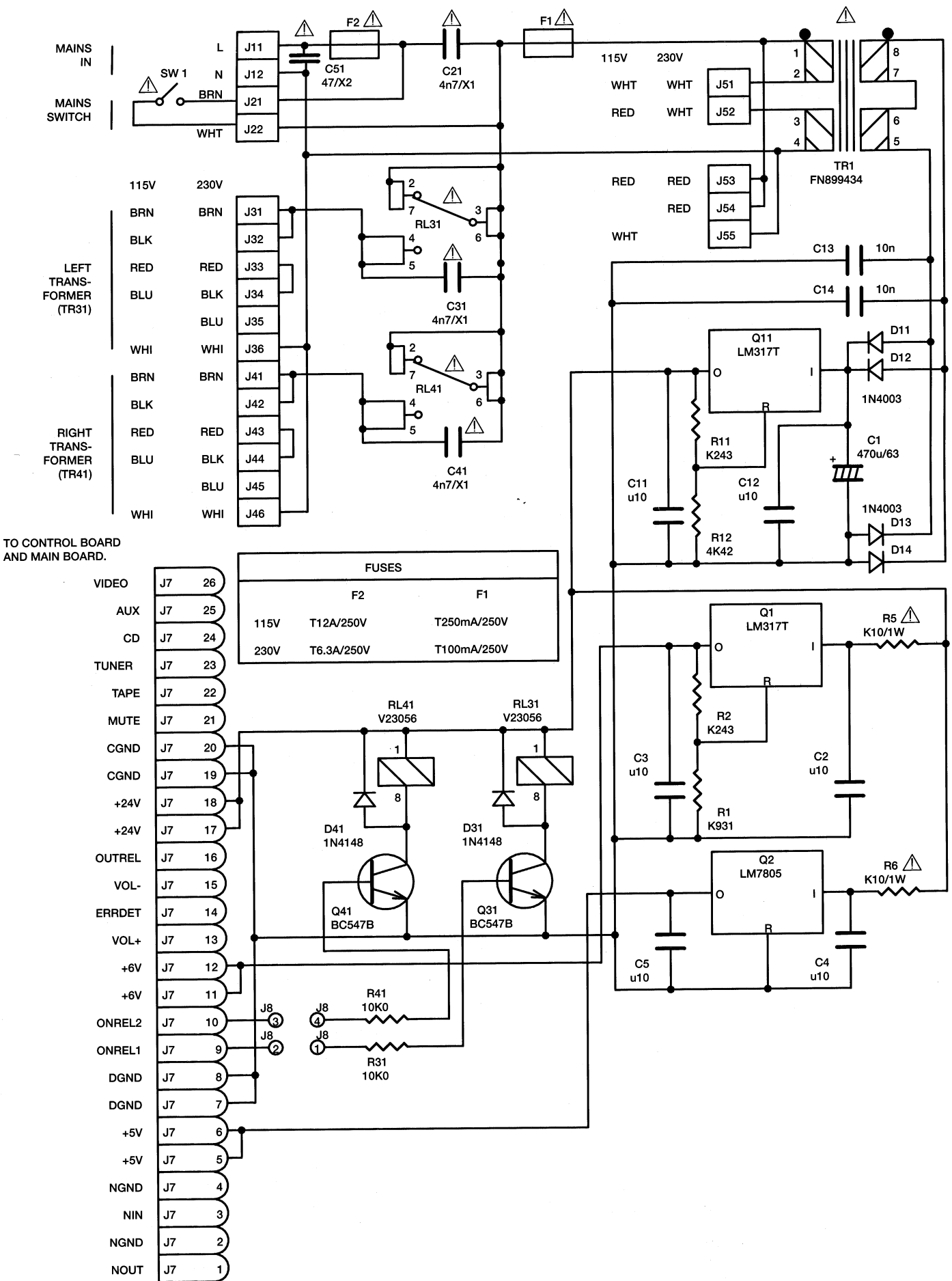

SCHEMATIC DIAGRAM FRONT PANEL BOARD

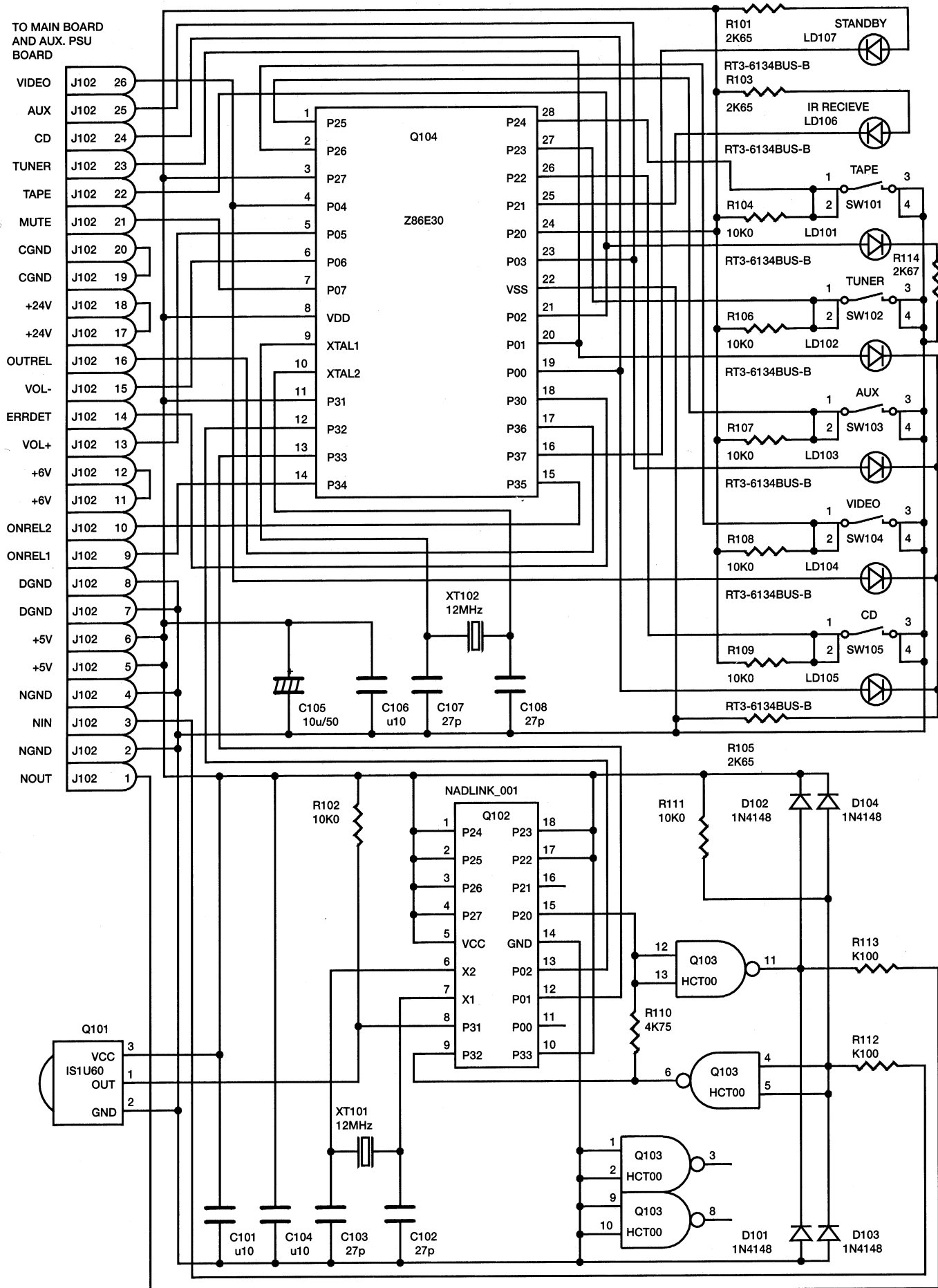

SCHEMATIC DIAGRAM

CONTROL INTERFACE

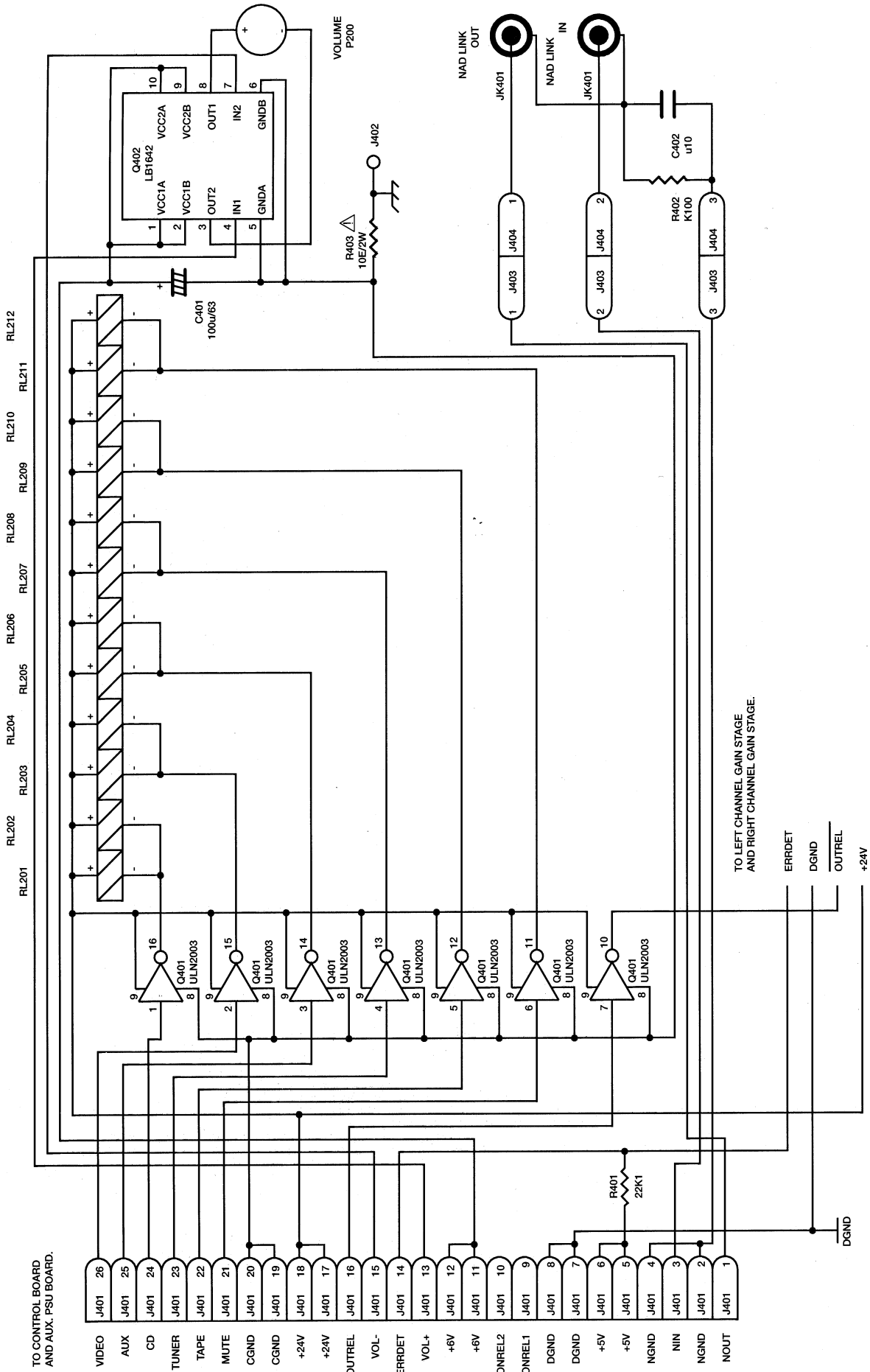

SCHEMATIC DIAGRAM

LEFT INPUT SELECTOR

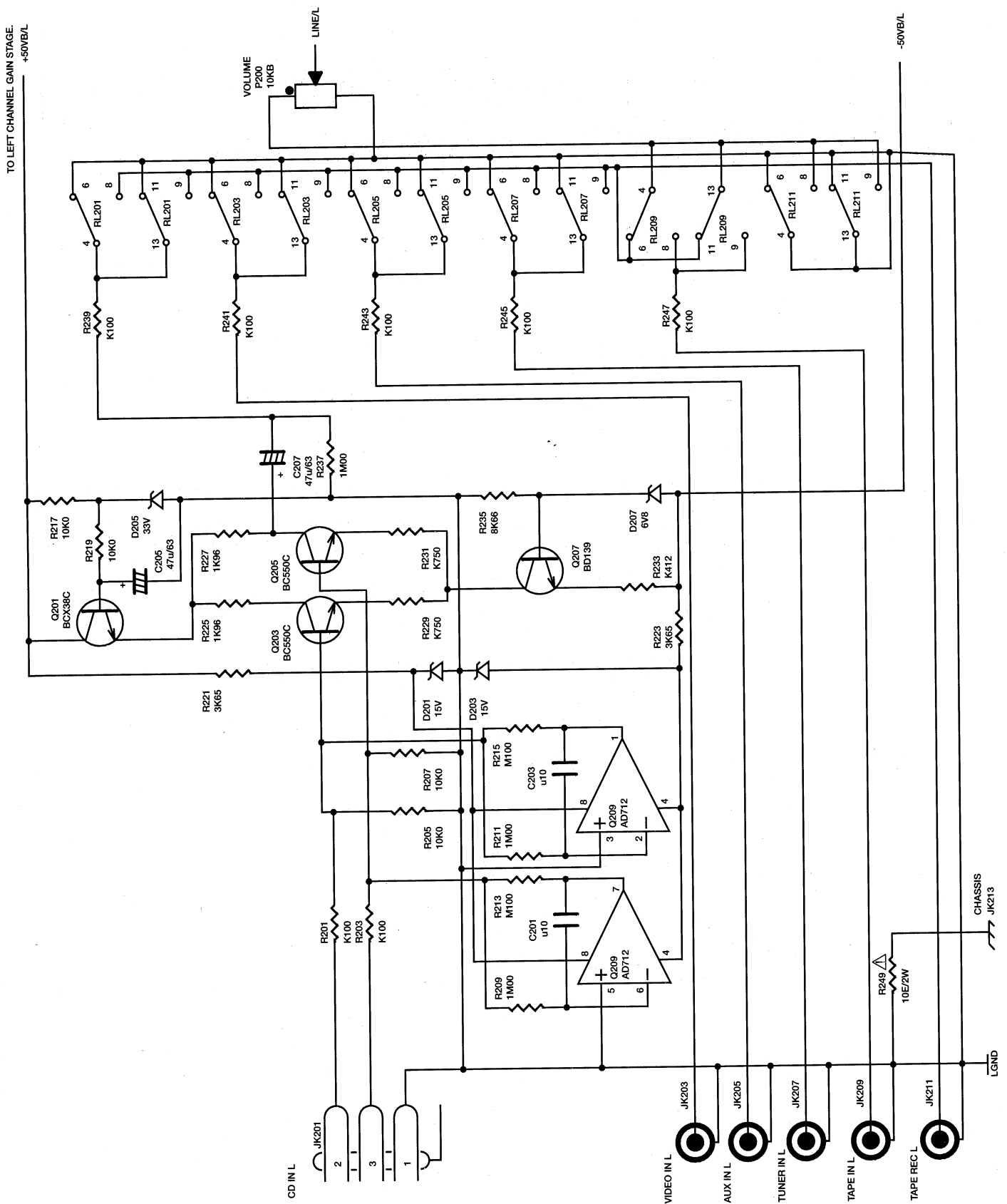

SCHEMATIC DIAGRAM RIGHT INPUT SELECTOR

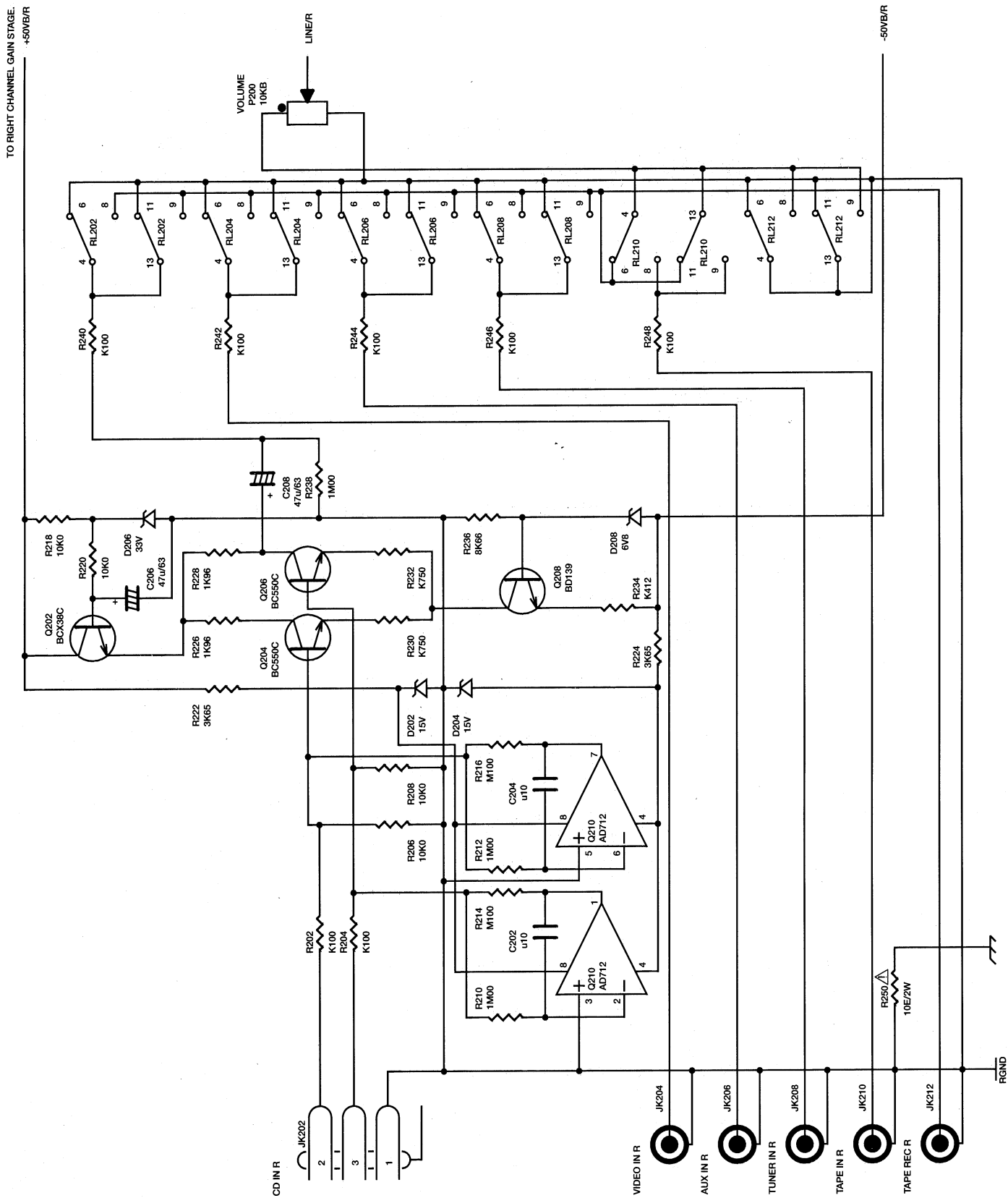

SCHEMATIC DIAGRAM LEFT GAIN STAGE

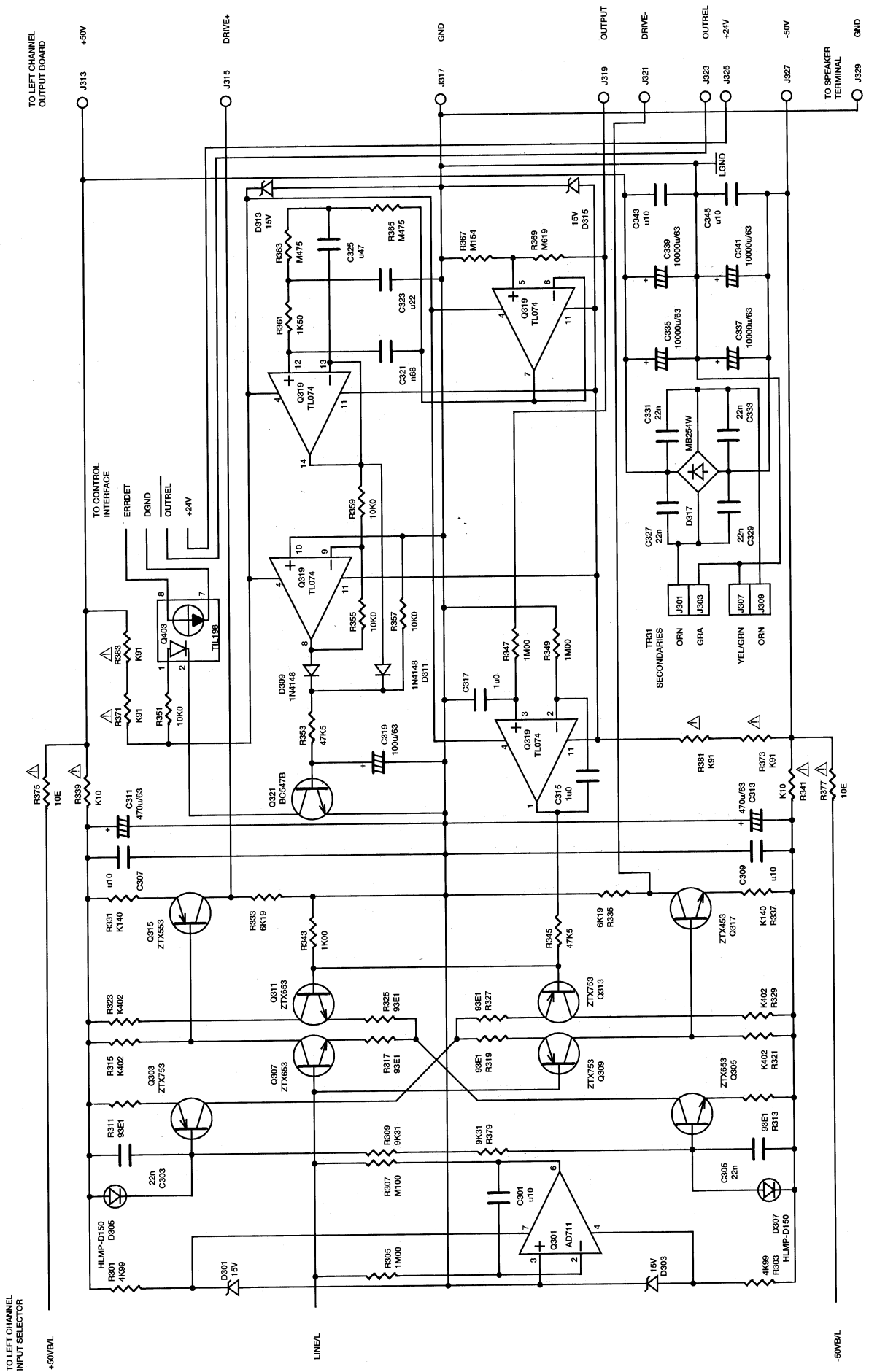

SCHEMATIC DIAGRAM RIGHT GAIN STAGE

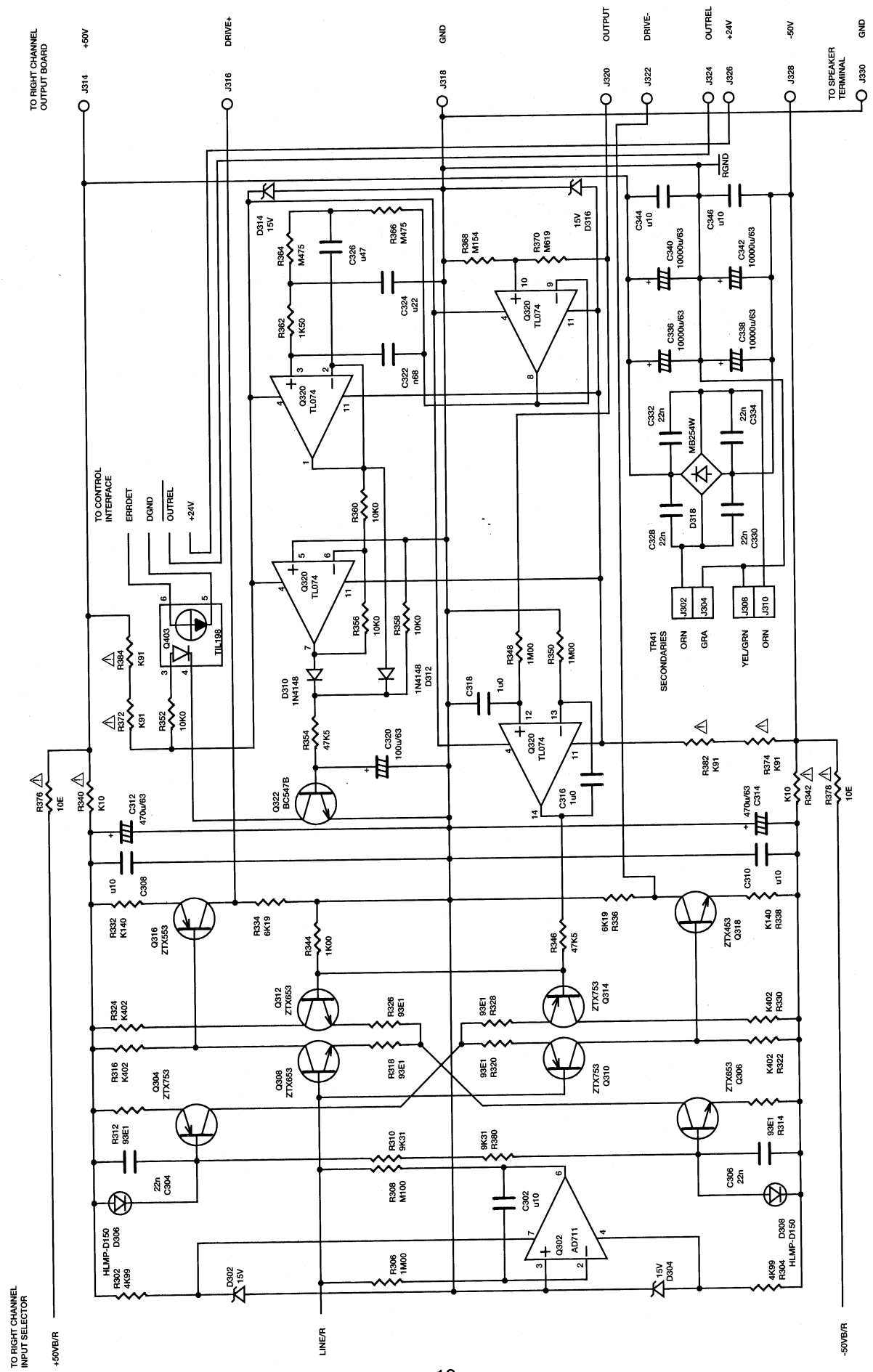

SCHEMATIC DIAGRAM

LEFT AMP

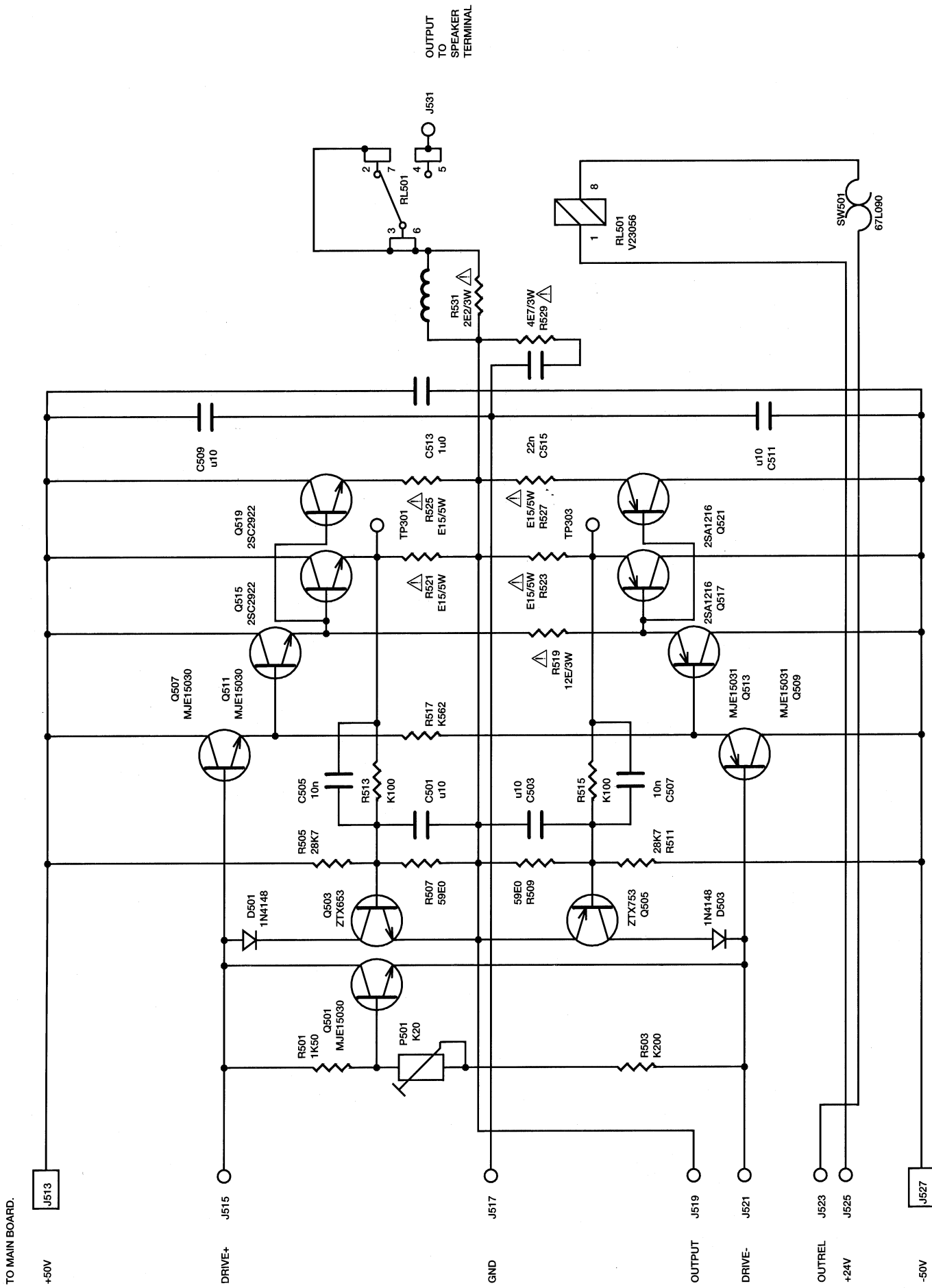

OUTPUT
TO
SPEAKER
TERMINAL

ADJUST P501 FOR 75mv BETWEEN TP301 AND TP303.

SCHEMATIC DIAGRAM RIGHT AMP

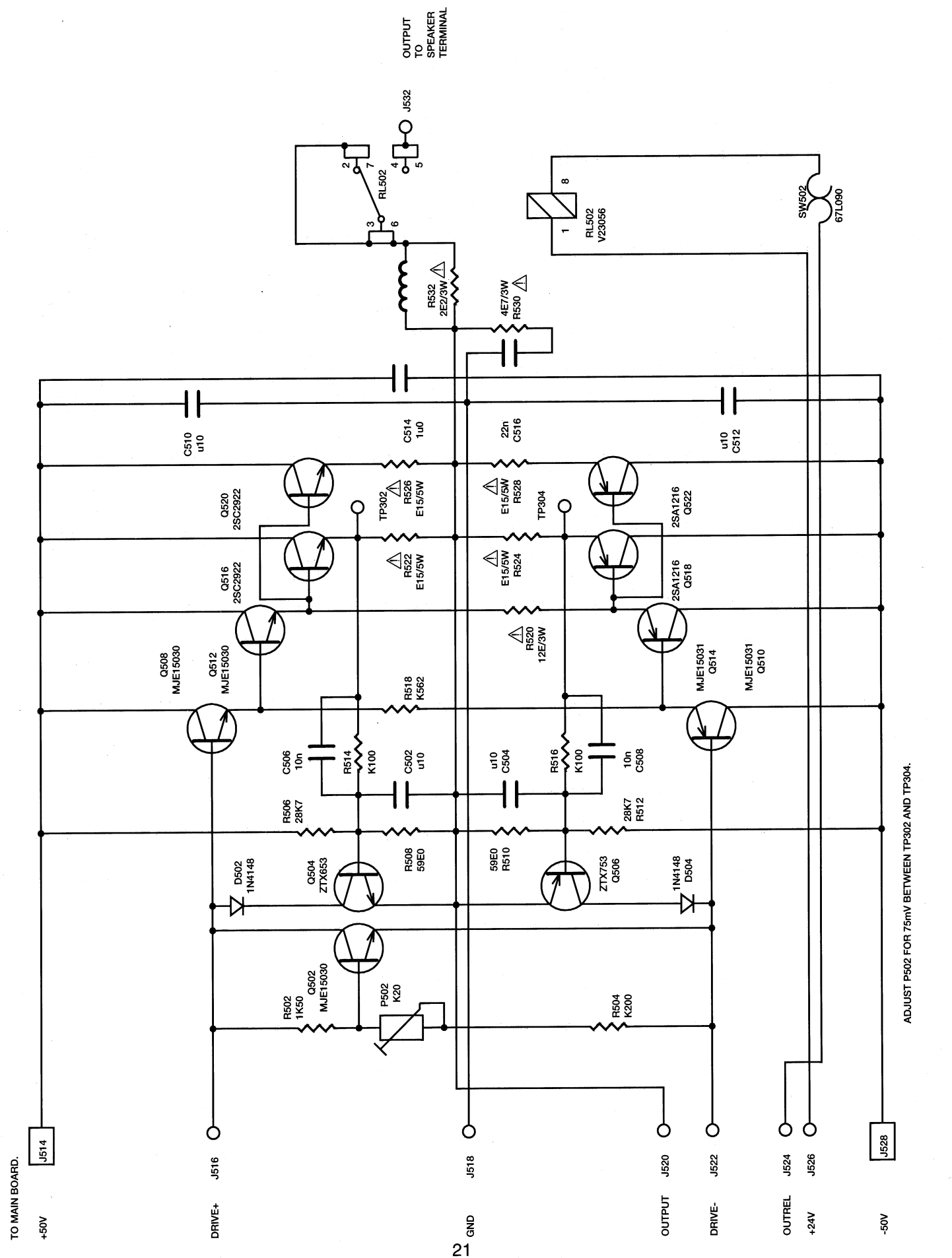

OUTPUT
TO
SPEAKER
TERMINAL

TO MAIN BOARD.
+50V
J514

DRIVE+
J516

21
GND
J518

OUTPUT
J520

DRIVE-
J522

OUTREL
J524

+24V
J526

-50V
J528

ADJUST P502 FOR 75mV BETWEEN TP302 AND TP304.

IC BLOCK DIAGRAM

Q209-Q210: AD712JN
HIGH PERFORMANCE DUAL OP-AMP

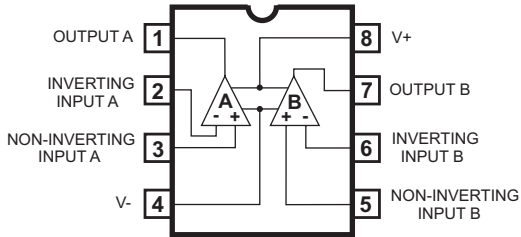

Q301-Q302: AD711JN
HIGH PERFORMANCE MONO OP-AMP

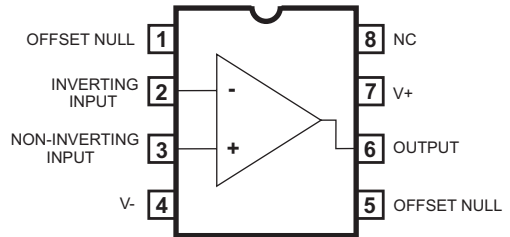

Q319-Q320: TL074CN
LOW NOISE QUAD OP-AMP

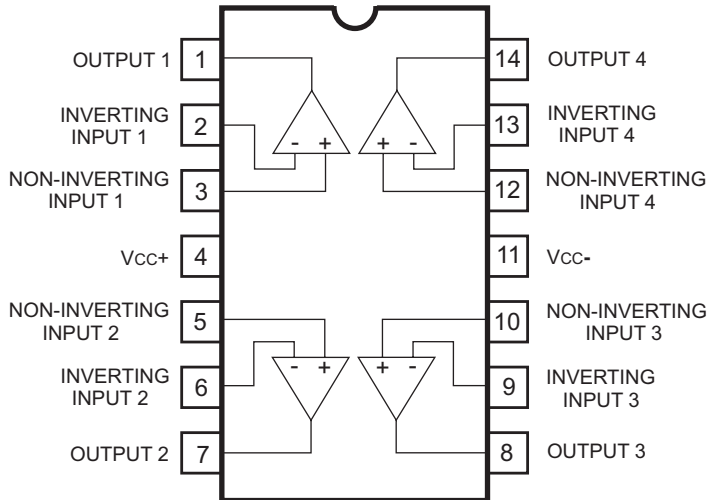

Q103: 74HCT00
2-INPUT QUAD NAND GATE

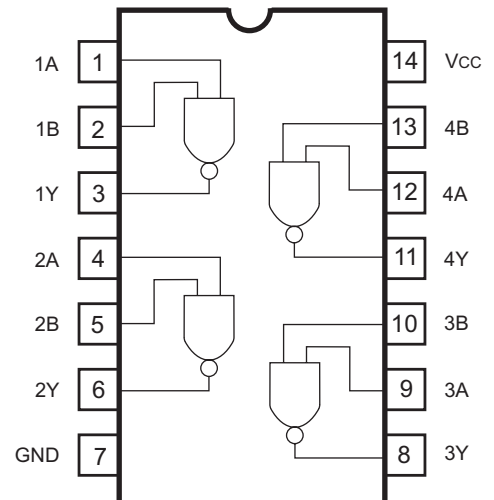

Q401: ULN2003A
7 DARLINGTON ARRAYS FOR RELAY DRIVE

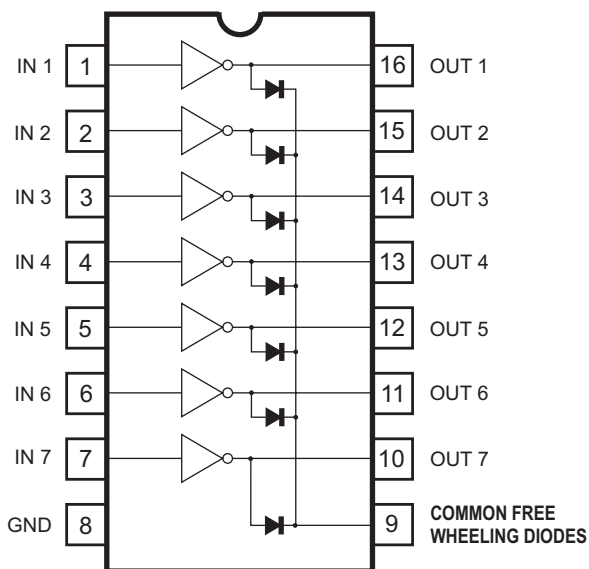

Q402: LB1642
MOTOR DRIVER

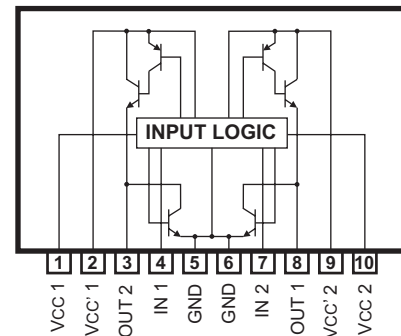

Q403: TIL198B
DUAL OPTOCOUPLER

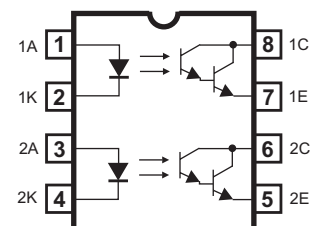

EXPLODED VIEW

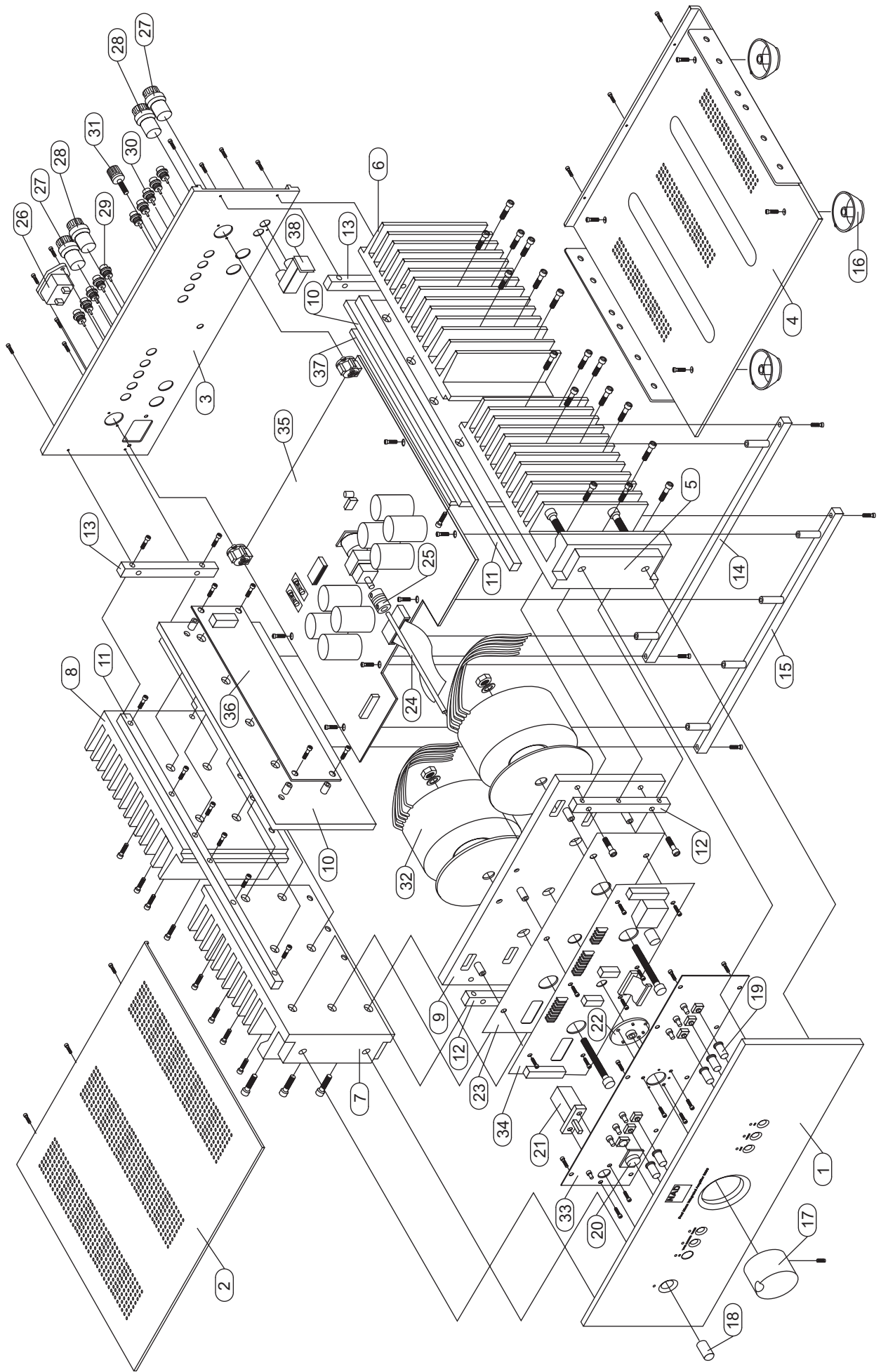

EXPLODED VIEW PARTS LIST

ITEM	PART NUMBER	DESCRIPTION	QTY.
1	S300-2002-4	FASCIA	1
2	S200-2005-2	TOP COVER	1
3*AH	S300-2004AH-4	REAR PANEL 120V	1
3*C	S300-2004C-4	REAR PANEL 230V	1
4	S300-2003-2	BASE PLATE	1
5	S300-2003-3	RIGHT FRONT HEATSINK	1
6	S300-2023-2	RIGHT REAR HEATSINK	1
7	S300-2013-3	LEFT FRONT HEATSINK	1
8	S300-2033-2	LEFT REAR HEATSINK	1
9	S300-2012-4	SUBFASCIA	1
10	S300-2043-3	HEATSINK PLATE	2
11	S300-2015-3	TOP COVER MOUNTING BAR	2
12	S300-2022-3	SUBFASCIA BAR	2
13	S300-2014-4	REAR PANEL BAR	2
14	S300-2006-2A	INPUT BOARD BAR 1	1
15	S300-2006-2B	INPUT BOARD BAR 2	1
16	S100-2013-2	FOOT W/ RUBBER CUSHION	4
17	S300-2032-2	VOLUME KNOB	1
18	S100-2011-3	10MM POWER BUTTON	1
19	S400-2121-1	6MM INPUT BUTTON	5
20	S100-2221-1	IRS LENS	1
21	S300-0205	POWER SWITCH	1
22	S300-2052	VOLUME BUSHING	1
23	S300-2112	ISOLATION PLATE	1
24	S300-2042-2	VOLUME SHAFT	1
25	BSK 44 02 40	VOLUME COUPLING	1
26	PX0690/28	AC INLET	1
27	WBT-745 BLACK	SPEAKER TERMINAL BLACK	2
28	WBT-745 RED	SPEAKER TERMINAL RED	2
29	S300-0202	RCA JACK WHITE	5
30	S300-0201	RCA JACK RED	5
31	S300-0206	GROUND TERMINAL	1
32	TI-65300A	TRANSFORMER	1
33	S300-0150	FRONT PANEL PCB	1
34	S300-0100	PSU PCB	1
35	S300-0151	INPUT STAGE PCB	1
36	S300-0140	LEFT POWER STAGE PCB	1
37	S300-0130	RIGHT POWER STAGE PCB	1
38	S300-0204	NAD LINK PCB	1

PACKING DIAGRAM

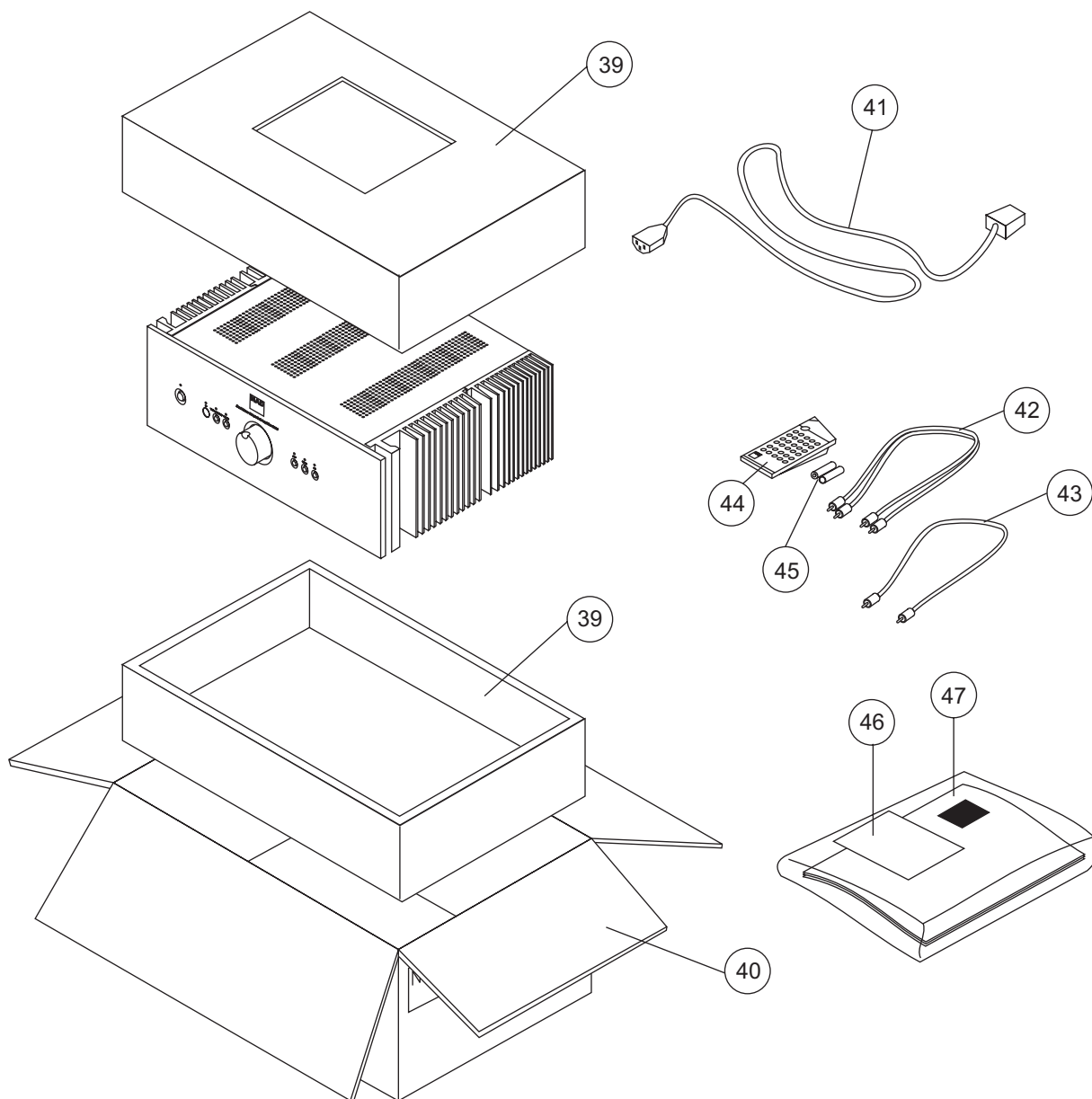

ITEM	PART NUMBER	DESCRIPTION	QTY.
39	311232	POLYFOAM	1 SET
40	S300-2010-A	CARTON BOX	1
41*AH	POW4	POWER CORD NEMA 1-15 POLARIZED	1
41*C	POW2	POWER CORD CEE (7) XVII	1
42	101-000A	AUDIO CABLE	1
43	101-000B	NAD LINK CABLE	1
44	RC 450	REMOTE CONTROL HANDSET	1
45	R03	BATTERY	1 SET
46	WARR	WARRANTY CARD	1
47	S300-IM	INSTRUCTION MANUAL	1

www.NADelectronics.com

**©2004 NAD ELECTRONICS INTERNATIONAL
A DIVISION OF LENBROOK INDUSTRIES LIMITED**

All rights reserved. No part of this publication may be reproduced, stored or transmitted in any form without the written permission of NAD Electronics International