

S 400

RDS FM TUNER

SERVICE MANUAL

S 400

RDS FM TUNER

NAD

FRONT PANEL / REAR PANEL VIEW

FRONT PANEL CONTROLS

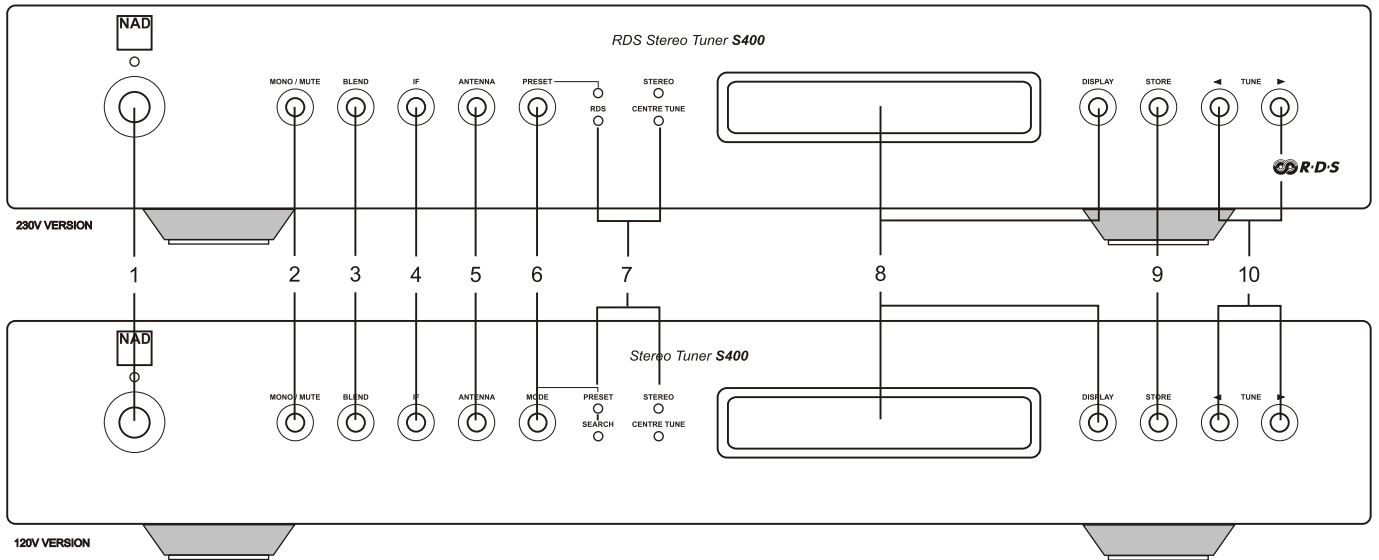

- | | | |
|-----------------|--------------------------|-----------------------------|
| 1. POWER SWITCH | 5. ANTENNA | 8. DISPLAY * DISPLAY BUTTON |
| 2. MONO/MUTE | 6. PRESET (230V VERSION) | 9. STORE |
| 3. BLEND | 6. MODE (120V VERSION) | 10. TUNE |
| 4. IF | 7. LED INDICATORS | |

 The graphic symbol of a lightning flash with an arrow point within a triangle signifies that there is dangerous voltage with the unit and it poses a hazard to anyone removing the cover to gain access to the interior of the unit. **Only qualified service personnel should make such an attempt.**

 The graphic symbol of an exclamation point within a triangle warns a user of the device that it is necessary to refer to the instruction manual and its warning for proper operation of the unit.

REAR PANEL CONNECTIONS

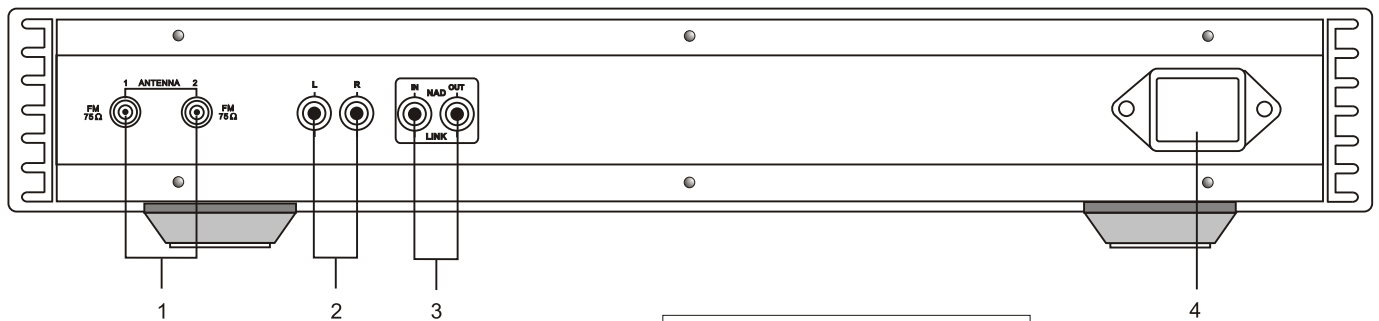

1. FM ANTENNA
2. OUTPUT
3. NAD-LINK IN/OUT
4. IEC AC MAINS INPUT

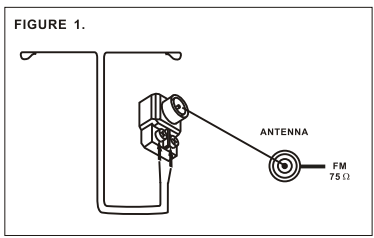

PRODUCT SAFETY SERVICING GUIDELINES FOR NAD PRODUCTS

CAUTION : DO NOT ATTEMPT TO MODIFY THIS PRODUCT IN ANY WAY, NEVER PERFORM CUSTOMIZED INSTALLATIONS WITHOUT MANUFACTURER'S APPROVAL. UNAUTHORIZED MODIFICATIONS WILL NOT ONLY VOID THE WARRANTY, BUT MAY LEAD TO YOUR BEING LIABLE FOR ANY RESULTING PROPERTY DAMAGE OR USER INJURY.

SERVICE WORK SHOULD BE PERFORMED ONLY AFTER YOU ARE THOROUGHLY FAMILIAR WITH ALL OF THE FOLLOWING SAFETY CHECKS AND SERVICING GUIDELINES. TO DO OTHERWISE, INCREASES THE RISK OF POTENTIAL HAZARDS AND INJURY TO THE USER.

WHILE SERVICING, USE AN ISOLATION TRANSFORMER FOR PROTECTION FROM A.C. LINE SHOCK.

SAFETY CHECKS

AFTER THE ORIGINAL SERVICE PROBLEM HAS BEEN CORRECTED. A CHECK SHOULD BE MADE OF THE FOLLOWING.

SUBJECT : FIRE & SHOCK HAZARD

1. BE SURE THAT ALL COMPONENTS ARE POSITIONED IN SUCH A WAY AS TO AVOID POSSIBILITY OF ADJACENT COMPONENT SHORTS. THIS IS ESPECIALLY IMPORTANT ON THOSE MODULES WHICH ARE TRANSPORTED TO AND FROM THE REPAIR SHOP.
2. NEVER RELEASE A REPAIR UNLESS ALL PROTECTIVE DEVICES SUCH AS INSULATORS, BARRIERS, COVERS, SHIELDS, STRAIN RELIEFS, POWER SUPPLY CORDS, AND OTHER HARDWARE HAVE BEEN REINSTALLED PER ORIGINAL DESIGN. BE SURE THAT THE SAFETY PURPOSE OF THE POLARIZED LINE PLUG HAS NOT BEEN DEFEATED.
3. SOLDERING MUST BE INSPECTED TO DISCOVER POSSIBLE COLD SOLDER JOINTS, SOLDER SPLASHES OR SHARP SOLDER POINTS. BE CERTAIN TO REMOVE ALL LOOSE FOREIGN PARTICLES.
4. CHECK FOR PHYSICAL EVIDENCE OF DAMAGE OR DETERIORATION TO PARTS AND COMPONENTS, FOR FRAYED LEADS, DAMAGED INSULATION (INCLUDING A.C. CORD), AND REPLACE IF NECESSARY. FOLLOW ORIGINAL LAYOUT, LEAD LENGTH AND DRESS.
5. NO LEAD OR COMPONENT SHOULD TOUCH A RECEIVING TUBE OR A RESISTOR RATED AT 1 WATT OR MORE. LEAD TENSION AROUND PROTRUDING METAL SURFACES MUST BE AVOIDED.
6. ALL CRITICAL COMPONENTS SUCH AS FUSES, FLAMEPROOF RESISTORS, CAPACITORS, ETC. MUST BE REPLACED WITH EXACT FACTORY TYPES, DO NOT USE REPLACEMENT COMPONENTS OTHER THAN THOSE SPECIFIED OR MAKE UNRECOMMENDED CIRCUIT MODIFICATIONS.
7. AFTER RE-ASSEMBLY OF THE SET ALWAYS PERFORM AN A.C. LEAKAGE TEST ON ALL EXPOSED METALLIC PARTS OF THE CABINET, (THE CHANNEL SELECTOR KNOB, ANTENNA TERMINALS, HANDLE AND SCREWS) TO BE SURE THE SET IS SAFE TO OPERATE WITHOUT DANGER OF ELECTRICAL SHOCK. DO NOT USE A LINE ISOLATION TRANSFORMER DURING THIS TEST USE AN A.C. VOLTMETER, HAVING 5000 OHMS PER VOLT OR MORE SENSITIVITY, IN THE FOLLOWING MANNER: CONNECT A 1500 OHM 10 WATT RESISTOR, PARALLELED BY A .15 MFD. 150.V A.C TYPE CAPACITOR BETWEEN A KNOWN GOOD EARTH GROUND (WATER PIPE, CONDUIT, ETC.) AND THE EXPOSED METALLIC PARTS, ONE AT A TIME. MEASURE THE A.C. VOLTAGE ACROSS THE COMBINATION OF 1500 OHM RESISTOR AND .15 MFD CAPACITOR. REVERSE THE A.C. PLUG AND REPEAT A.C. VOLTAGE MEASUREMENTS FOR EACH EXPOSED METALLIC PART. VOLTAGE MEASURED MUST NOT EXCEED 75 VOLTS R.M.S. THIS CORRESPONDS TO 0.5 MILLIAMPER A.C ANY VALUE EXCEEDING THIS LIMIT CONSTITUTES A POTENTIAL SHOCK HAZARD AND MUST BE CORRECTED IMMEDIATELY.

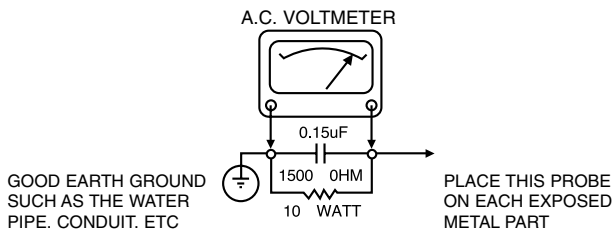

SUBJECT: GRAPHIC SYMBOLS



THE LIGHTNING FLASH WITH APROWHEAD SYMBOL, WITHIN AN EQUILATERAL TRIANGLE, IS INTENDED TO ALERT THE SERVICE PERSONNEL TO THE PRESENCE OF UNINSULATED "DANGEROUS VOLTAGE" THAT MAY BE OF SUFFICIENT MAGNITUDE TO CONSTITUTE A RISK OF ELECTRIC SHOCK.



THE EXCLAMATION POINT WITHIN AN EQUILATERAL TRIANGLE IS INTENDED TO ALERT THE SERVICE PERSONNEL TO THE PRESENCE OF IMPORTANT SAFETY INFORMATION IN SERVICE LITERATURE.

SUBJECT : X-RADIATION

1. BE SURE PROCEDURES AND INSTRUCTIONS TO ALL SERVICE PERSONNEL COVER THE SUBJECT OF X-RADIATION. THE ONLY POTENTIAL SOURCE OF X-RAYS IN CURRENT T.V. RECEIVERS IS THE PICTURE TUBE. HOWEVER, THIS TUBE DOES NOT EMIT X-RAYS WHEN THE HIGH VOLTAGE IS AT THE FACTORY SPECIFIED LEVEL. THE PROPER VALUE IS GIVEN IN THE APPLICABLE SCHEMATIC. OPERATION AT HIGHER VOLTAGES MAY CAUSE A FAILURE OF THE PICTURE TUBE OR HIGH VOLTAGE SUPPLY AND, UNDER CERTAIN CIRCUMSTANCES, MAY PRODUCE RADIATION IN EXCESS OF DESIRABLE LEVELS.
2. ONLY FACTORY SPECIFIED C.R.T. ANODE CONNECTORS MUST BE USED. DEGAUSSING SHIELDS ALSO SERVE AS AN X-RAY SHIELD IN COLOR SETS, ALWAYS RE-INSTALL THEM.
3. IT IS ESSENTIAL THAT SERVICE PERSONNEL HAVE AVAILABLE AN ACCURATE AND RELIABLE HIGH VOLTAGE METER. THE CALIBRATION OF THE METER SHOULD BE CHECKED PERIODICALLY AGAINST A REFERENCE STANDARD, SUCH AS THE ONE AVAILABLE AT YOUR DISTRIBUTOR.
4. WHEN THE HIGH VOLTAGE CIRCUITRY IS OPERATING PROPERLY THERE IS NO POSSIBILITY OF AN X-RADIATION PROBLEM. EVERY TIME A COLOR CHASSIS IS SERVICED. THE BRIGHTNESS SHOULD BE RUN UP AND DOWN WHILE MONITORING THE HIGH VOLTAGE WITH A METER TO BE CERTAIN THAT THE HIGH VOLTAGE DOES NOT EXCEED THE SPECIFIED VALUE AND THAT IT IS REGULATING CORRECTLY. WE SUGGEST THAT YOU AND YOUR SERVICE ORGANIZATION REVIEW TEST PROCEDURES SO THAT VOLTAGE REGULATION IS ALWAYS CHECKED AS A STANDARD SERVICING PROCEDURE AND THAT THE HIGH VOLTAGE READING BE RECORDED ON EACH CUSTOMER'S INVOICE.
5. WHEN TROUBLESHOOTING AND MAKING TEST MEASUREMENTS IN A PRODUCT WITH A PROBLEM OF EXCESSIVE HIGH VOLTAGE, AVOID BEING UNNECESSARILY CLOSE TO THE PICTURE TUBE AND THE HIGH VOLTAGE SUPPLY. DO NOT OPERATE THE PRODUCT LONGER THAN IT IS NECESSARY TO LOCATE THE CAUSE OF EXCESSIVE VOLTAGE.
6. REFER TO HV. B+ AND SHUTDOWN ADJUSTMENT PROCEDURES DESCRIBED IN THE APPROPRIATE SCHEMATIC AND DIAGRAMS (WHERE USED).

SUBJECT: IMPLOSION

1. ALL DIRECT VIEWED PICTURE TUBES ARE EQUIPPED WITH AN INTEGRAL IMPLOSION PROTECTION SYSTEM, BUT CARE SHOULD BE TAKEN TO AVOID DAMAGE DURING INSTALLATION, AVOID SCRATCHING THE TUBE. IF SCRATCHED REPLACE IT.
2. USE ONLY RECOMMENDED FACTORY REPLACEMENT TUBES.

SUBJECT : TIPS ON PROPER INSTALLATION

1. NEVER INSTALL ANY PRODUCT IN A CLOSED-IN RECESS, CUBBY-HOLE OR CLOSELY FITTING SHELF SPACE, OVER OR CLOSE TO HEAT DUCT, OR IN THE PATH OF HEATED AIR FLOW.
2. AVOID CONDITIONS OF HIGH HUMIDITY SUCH AS: OUTDOOR PATIO INSTALLATIONS WHERE DEW IS A FACTOR, NEAR STEAM RADIATORS WHERE STEAM LEAKAGE IS A FACTOR, ETC.
3. AVOID PLACEMENT WHERE DRAPERIES MAY OBSTRUCT REAR VENTING. THE CUSTOMER SHOULD ALSO AVOID THE USE OF DECORATIVE SCARVES OR OTHER COVERINGS WHICH MIGHT OBSTRUCT VENTILATION.
4. WALL AND SHELF MOUNTED INSTALLATIONS USING A COMMERCIAL MOUNTING KIT, MUST FOLLOW THE FACTORY APPROVED MOUNTING INSTRUCTIONS. A PRODUCT MOUNTED TO A SHELF OR PLATFORM MUST RETAIN ITS ORIGINAL FEET (OR THE EQUIVALENT THICKNESS IN SPACERS) TO PROVIDE ADEQUATE AIR FLOW ACROSS THE BOTTOM. BOLTS OR SCREWS USED FOR FASTENERS MUST NOT TOUCH ANY PARTS OR WIRING. PERFORM LEAKAGE TEST ON CUSTOMIZED INSTALLATIONS.
5. CAUTION CUSTOMERS AGAINST THE MOUNTING OF A PRODUCT ON SLOPING SHELF OR A TILTED POSITION, UNLESS THE PRODUCT IS PROPERLY SECURED.
6. A PRODUCT ON A ROLL-ABOUT CART SHOULD BE STABLE ON ITS MOUNTING TO THE CART. CAUTION THE CUSTOMER ON THE HAZARDS OF TRYING TO ROLL A CART WITH SMALL CASTERS ACROSS THRESHOLDS OR DEEP PILE CARPETS.
7. CAUTION CUSTOMERS AGAINST THE USE OF A CART OR STAND WHICH HAS NOT BEEN LISTED BY UNDERWRITERS LABORATORIES, INC. FOR USE WITH THEIR SPECIFIC MODEL OF TELEVISION RECEIVER OR GENERALLY APPROVED FOR USE WITH T.V.'S OF THE SAME OR LARGER SCREEN SIZE.
8. CAUTION CUSTOMERS AGAINST THE USE OF EXTENSION CORDS. EXPLAIN THAT A FOREST OF EXTENSIONS SPROUTING FROM A SINGLE OUTLET CAN LEAD TO DISASTROUS CONSEQUENCES TO HOME AND FAMILY.

NAD S400

ALIGNMENT PROCEDURE FOR NAD S400:

EQUIPMENT REQUIRED FOR ALIGNMENT PROCEDURE:

- FM RF signal generator capable of 75MHz to 109MHz output @ 75 Ω that can separately modulate left and right channels (Panasonic model # VP-7637A or equivalent)
- DMM with a basic accuracy of better than +/- 0.05%.
- High impedance (10 M Ω) dual channel audio AC voltmeter with decibel readout with accuracy of better than +/- 3%.
- Dual channel oscilloscope that has greater than 20MHz bandwidth.
- Non-Ferris tuning tools.

ALIGNMENT PROCEDURE:

WARNING: MOST OF THE ALIGNMENT POINTS AND ADJUSTMENTS ARE FOUND UNDER A SEALED BY SOLDER SHIELD. NORMALLY THERE SHOULD NOT BE A REASON FOR ACCESS TO THE ALIGNMENT POINTS AND ADJUSTMENTS, UNLESS PARTS HAVE BEEN REPLACED. ONLY ATTEMPT ALIGNMENT IF ALL EQUIPMENT MENTIONED ABOVE IS AVAILABLE AND ONLY IF QUALIFIED PERSONNEL PERFORM THE ALIGNMENT.

Depending on the country, the S400 can be setup differently via the front panel buttons. Hold down the **MODE** button while switching on the power. You now see a start up menu, where you can toggle between the various menu options with the **DISPLAY** button and save the choice with the **STORE** button.

For continental US select:

BAND = EU-USA (87.500 MHz to 108.500 MHz)

EQ = 75us

AUTO STEP = 100kHz,

DELETE PRESETS? = (DISPLAY button = yes, STORE button = no)?

For Europe select:

BAND = EU-USA (87.500 MHz to 108.500 MHz)

EQ = 50us

AUTO STEP = 50kHz,

DELETE PRESETS? = (DISPLAY button = yes, STORE button = no)?

For Japan select:

BAND = JAPAN (75.500 MHz to 90.500 MHz)

EQ = 75us

AUTO STEP = 100kHz,

DELETE PRESETS? = (DISPLAY button = yes, STORE button = no)?

Alignment of RF front-end:

- 1) Press the **IF**-button to select **IF NARROW**. Press the **ANTENNA**-button and select **ANTENNA 2**. Then connect an RF signal generator to **ANTENNA** port #2 and set to:
Amplitude = 45 dBu
Pilot tone = off
Modulation = off
Frequency = 98.000 MHz.

NAD S400

- 2) Tune the **S400** to 108.500 MHz (90.500 MHz for Japan). Looking at the **S400** from the front, measure with a DMM at the right hand side of **R21** found at position "R6" on the board. Adjust **L13** until the tuning voltage is 10.0V DC.
- 3) Tune the **S400** to 98,000 MHz (83.00 MHz for Japan). Measure with an oscilloscope, the IF-signal 10.7 MHz at the common point between **CF3** and **CF4** found at position "O4" (see Figure 1). This point will be "DC voltage free". **Leave the oscilloscope set to this point until told to remove it.** In the order listed below:
 - Adjust **L10** until the IF-signal for maximum setting.
 - Adjust **L7** until the IF-signal for maximum setting.
 - Adjust **L1** until the IF-signal for maximum setting.
 - Readjust **L10**, **L7** and **L1** until there is no more improvement for the maximum settings.

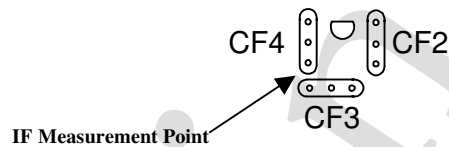

Figure 1

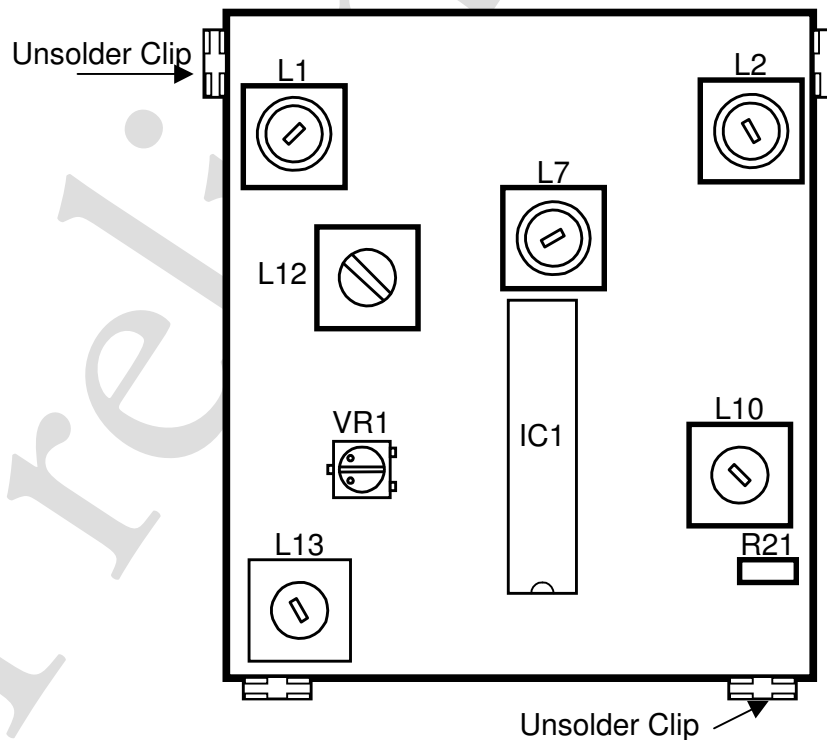

Figure 2

NAD S400

- 4) With the same oscilloscope setup as in procedure #3, press the **ANTENNA** button and select **ANTENNA** port #1. Check that the IF-signal is reduced by a minimum of 40 dB.
- 5) Connect the signal generator to **ANTENNA** port #1. With the same oscilloscope setup as in procedure #3, adjust **L2** until the IF-signal is at maximum setting. Press the **ANTENNA** button and select **ANTENNA** port #2. Check that the IF-signal is reduced by a minimum of 40 dB.

NOTE: Return to step #3 and perform the same alignment procedure but substitute **L2** for **L1**. Continue to align **L10**, **L7**, **L2**, and **L1**, until there is no improvement in IF-level maximum level between the two antenna ports, and that the isolation between the two ports is greater than 40 dB.

Alignment of IF Section:

- 6) Connect an RF signal generator to **ANTENNA** port #1 and set to:
Amplitude = 45 dBu
Pilot tone = off
Modulation = off
Frequency = 98.000 MHz.

Press the **ANTENNA**-button and select **ANTENNA** port #1. Press the **IF**-button to select **IF WIDE**. With the same oscilloscope setup as in procedure #3, check that the IF-signal had increased approximately 3 dB compared to **IF NARROW**.

Remove the oscilloscope probe from the common point between CF3 and CF4.

- 7) Connect an RF signal generator to **ANTENNA** port #1 and set to:
Amplitude = 70 dBu
Pilot tone = off
Modulation = off
Frequency = 98.000 MHz.

Adjust **L13** (or VR1) until the centre-tune LED turns on. Fine adjust **VR1** so that it lights from approximately 97,965 MHz. to 98,035 MHz equally.

Alignment of Audio Section:

- 8) Set the **S400** as the following:
Press the **IF**-button to select **IF WIDE**.
Press the **ANTENNA**-button and select **ANTENNA 1**.
Press the **MONO/MUTE**-button to **MUTE OFF MONO**.
Press the **BLEND**-button to **BLEND OFF**.
Press the **BANDWIDTH**-button to **BANDWIDTH WIDE**.
Tune the **S400** to 98.00 MHz.
- 9) Connect an audio AC voltmeter with decibel display to both the right and left audio output jacks. Set the AC-voltmeter to negative 30 dB range. **Leave the audio AC-voltmeter attached to the S400 audio output jacks until told to remove it.**
Then connect an RF signal generator to **ANTENNA** port #1 and set to:
Amplitude = 45 dBu
Pilot tone = on (19 kHz @ 10%)
Modulation = off
Frequency = 98,00 MHz
- 10) Adjust **L3** for a minimum 19 kHz output at the right audio jack.
- 11) Adjust **L4** for a minimum 19 kHz output at the left audio jack

NAD S400

- 12) With the audio AC-voltmeter connected as in procedure #9, select 0 db range for both channels. Connect an RF signal generator to **ANTENNA** port #1 and set to:
Amplitude = 65 dBu
Pilot tone = on (19 kHz @ 10%)
Modulation = 100% (including pilot tone) [1kHz @ +/- 75 kHz L+R and L-R].
Frequency = 98,000 MHz.
- 13) Set the **S400** as the following:
Press the **IF**-button to select **IF WIDE**.
Press the **ANTENNA**-button and select **ANTENNA 1**.
Press the **MONO/MUTE**-button to **MUTE ON STEREO**.
Press the **BLEND**-button to **BLEND OFF**.
Press the **BANDWIDTH**-button to **BANDWIDTH WIDE**.
Tune the **S400** to 98.00 MHz.
- 14) Check that the audio output is approximately 0 dB +/- 1 dB (775 mV rms) in both right and left output jacks.
 1. Turn the variable capacitor C37 so that the capacitor fins do not mesh, then switch off the modulation in the right side of the RF signal generator. Adjust **L12** until minimum audio output is measured in the right side. **Record this minimum output level**.
 2. Switch on the modulation in the right side of the RF signal generator. Switch off the modulation in the left side of the RF signal generator. Adjust **L12** until minimum audio output is measured in the left side. **Record this minimum output level**.

Use the side with the worst channel separation to adjust **L12**, by repeating the above two steps.
After adjusting **L12** adjust **C37** to minimum output level (maximum channel separation).
Channel separation should be 45 dB (+/- 5 dB).
- 15) Press the **IF**-button to select **IF NARROW**.
Check that the channel separation drops approximately 10 dB (+/- 5dB) at the audio output jacks.
- 16) Press the **BLEND**-button to select **BLEND ON**.
Check that the channel separation drops to approximately 15 dB. (+/- 3 dB) at the audio output jacks.

Remove the audio AC-voltmeter from the audio output jacks, as well as the RF signal generator from the antenna port.
- 17) Set the **S400** to default settings for the tuner as the following:
Press the **IF**-button to select **IF WIDE**.
Press the **ANTENNA**-button and select **ANTENNA 1**.
Press the **MONO/MUTE**-button to **MUTE ON STEREO**.
Press the **BLEND**-button to **BLEND OFF**.
Press the **BANDWIDTH**-button to **BANDWIDTH WIDE**.
After 10 sec. the settings will be stored.

NAD S400

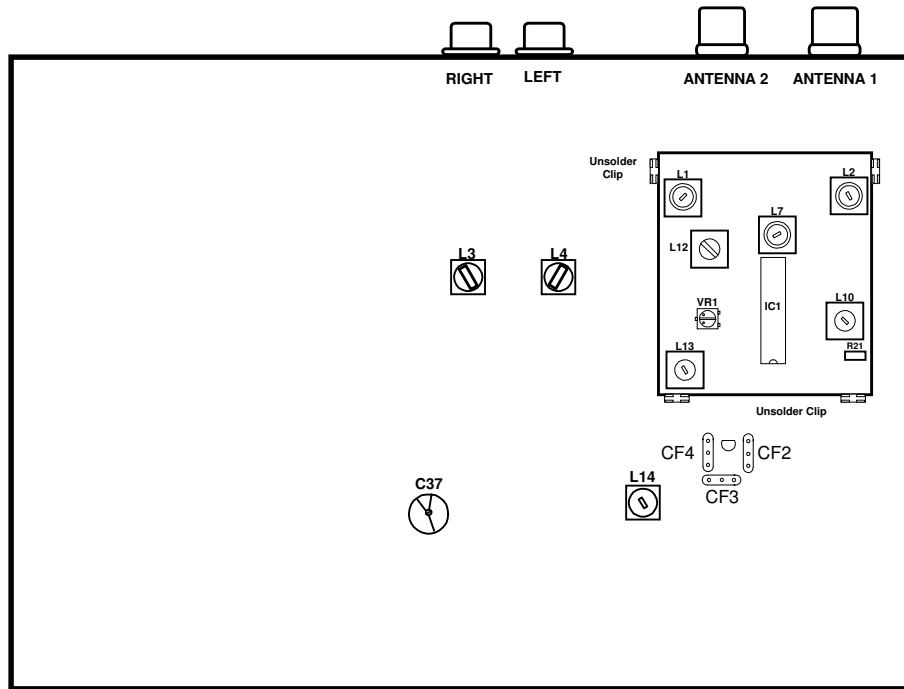

NAD S400

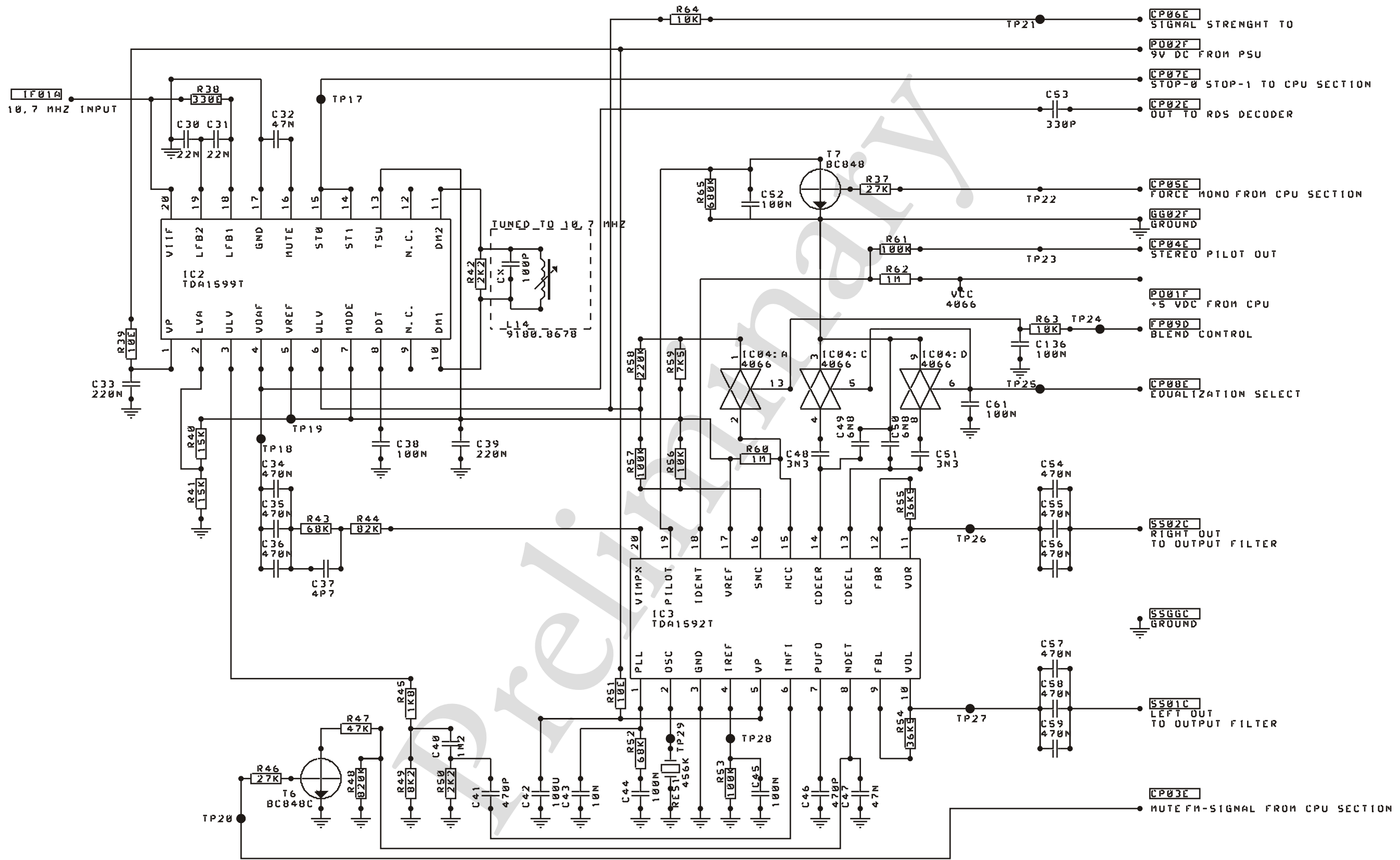

Title		
IF-SECTION AND STEREODECODER		
Size	Number	Revision
A3	NAD040_03_01	1, 1
Date:	17-OCT 2000	Sheet 3 of 34
File:	E:\SCH\040_0301/1	Drawn By: KIRALY

NAD S400

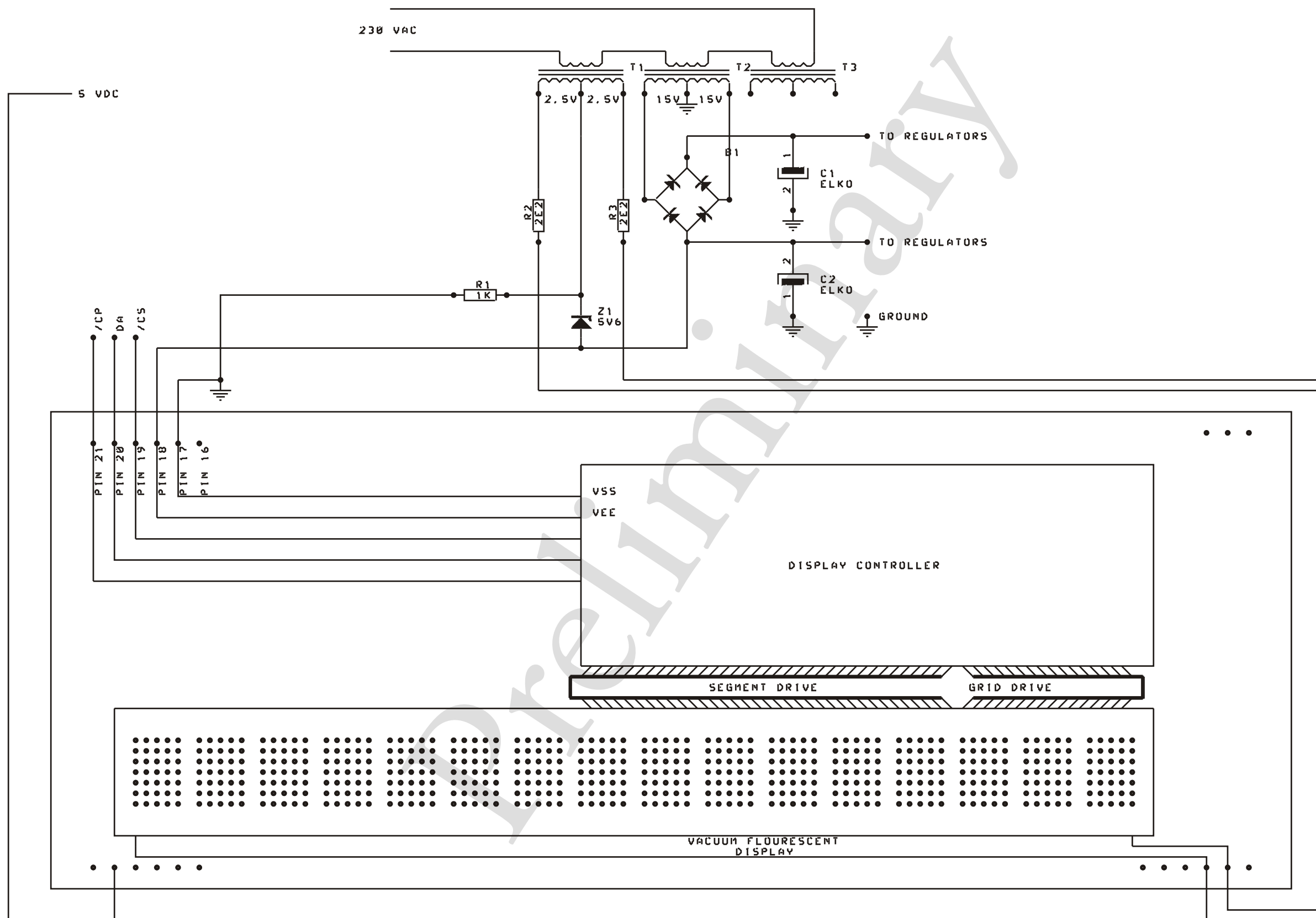

Title		
Size	Number	Revision
A3		
Date:	17-OCT 2000	Sheet of
File:	E:\SCH\040_0601/2	Drawn By:

NAD S400

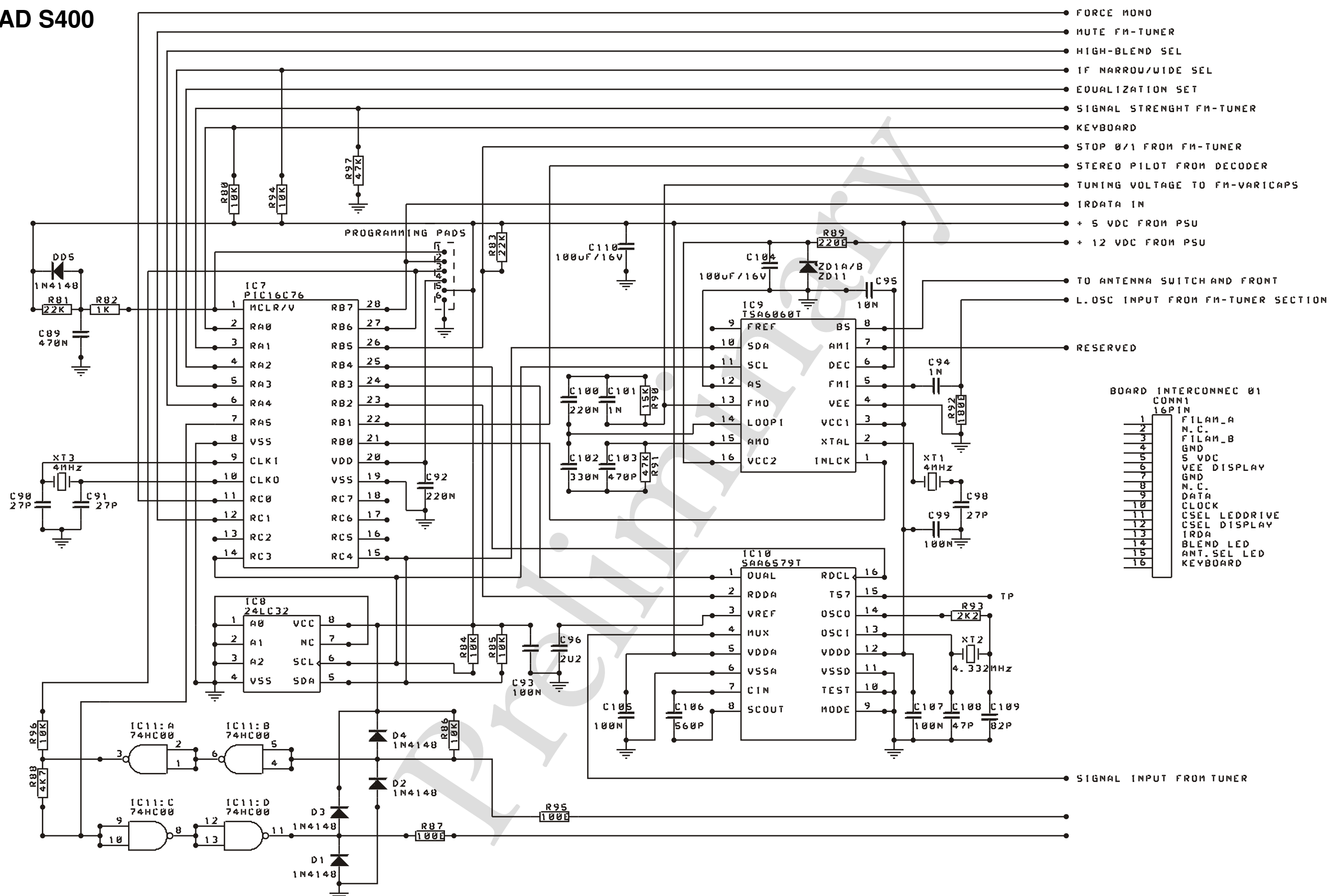

BOARD INTERCONNEC 01
CONN1
16PIN

1	FILAM_A
2	N.C.
3	FILAM_B
4	GND
5	5 VDC
6	VEE DISPLAY
7	GND
8	N.C.
9	DATA
10	CLOCK
11	CSEL LEDDRIVE
12	CSEL DISPLAY
13	IRDA
14	BLEND LED
15	ANT. SEL LED
16	KEYBOARD

REMARK: CON9
PROGRAMMING:
AFTER PROGRAMMING
PIN 4 AND 5 MUST
BE SHORTENED.
(+VDD TO CPU)

Title CPU, RDS AND SYNTHESIZER		
Size A3	Number NAD040-05_01	Revision 1,0
Date: 17-OCT 2000	Sheet 3 of 10	
File: E:\SCH\040_0501/1	Drawn By: T. KIRALY	

NAD S400

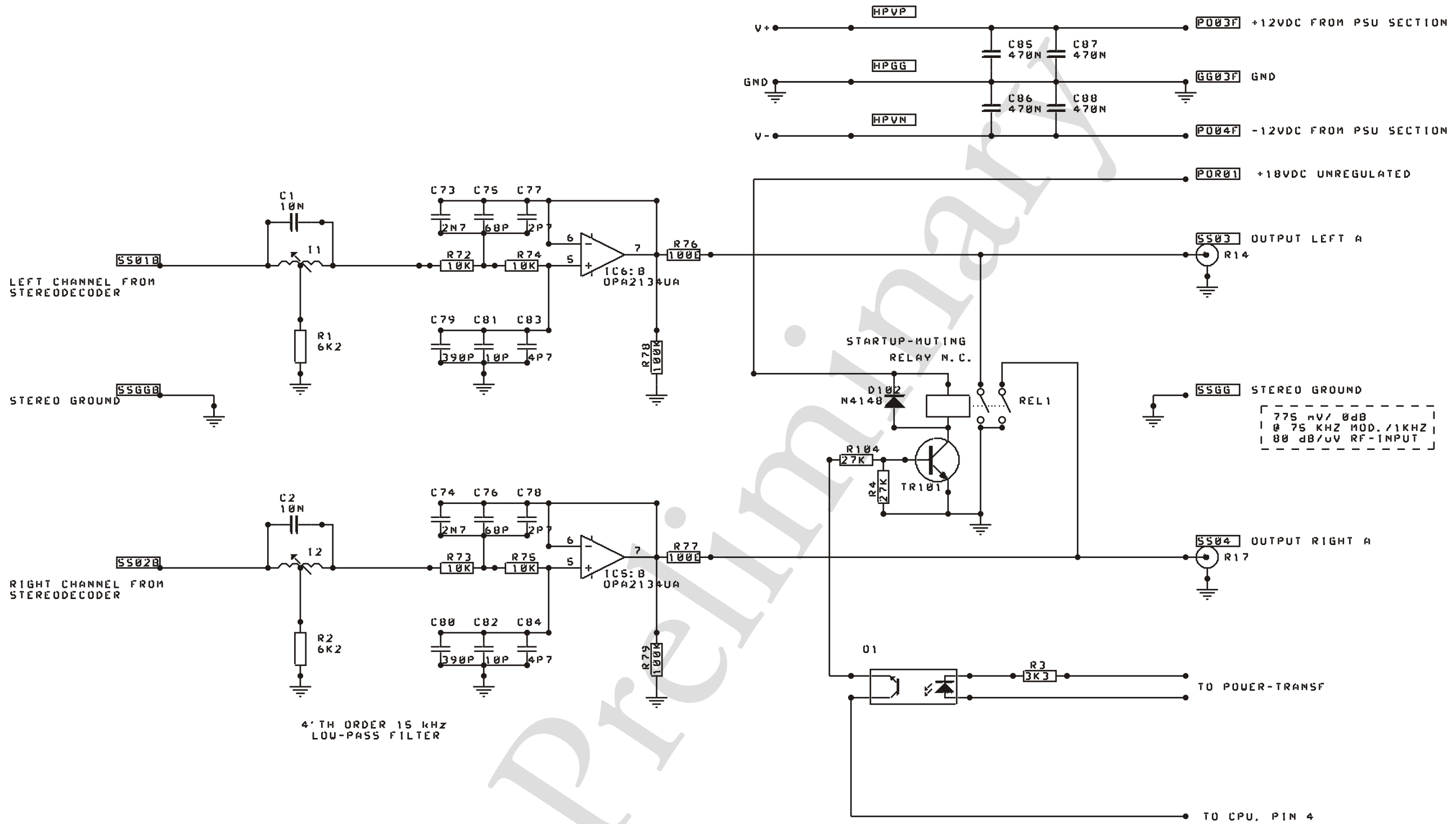

Title		
FILTER AND SIGNAL OUTPUT SECTION.		
Size	Number	Revision
A3	NAD040_04_03	3.0
Date:	16-JUN 1999	Sheet 4 of 34
File:	C:\WORK\S400\040_0	Drawn By: T. KIRALY

NAD S400

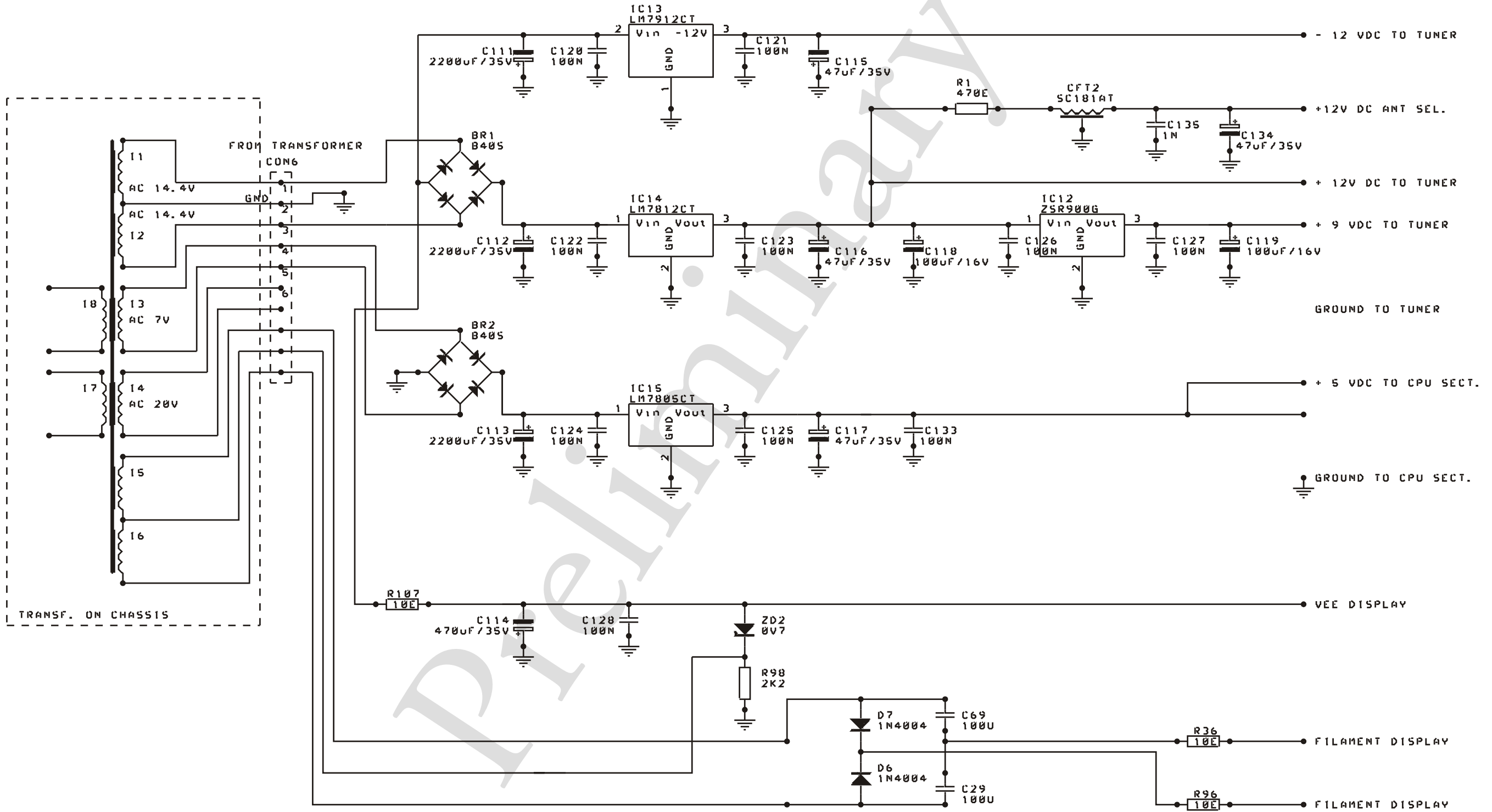

Title		
POWERSUPPLY AND CONNECTIONS		
Size	Number	Revision
A3	NAD 040_07_02	2,0
Date: 17-OCT 2000	Sheet 7 of 34	
File: E:\SCH\040_0701\1	Drawn By: KIRALY	

NAD S400

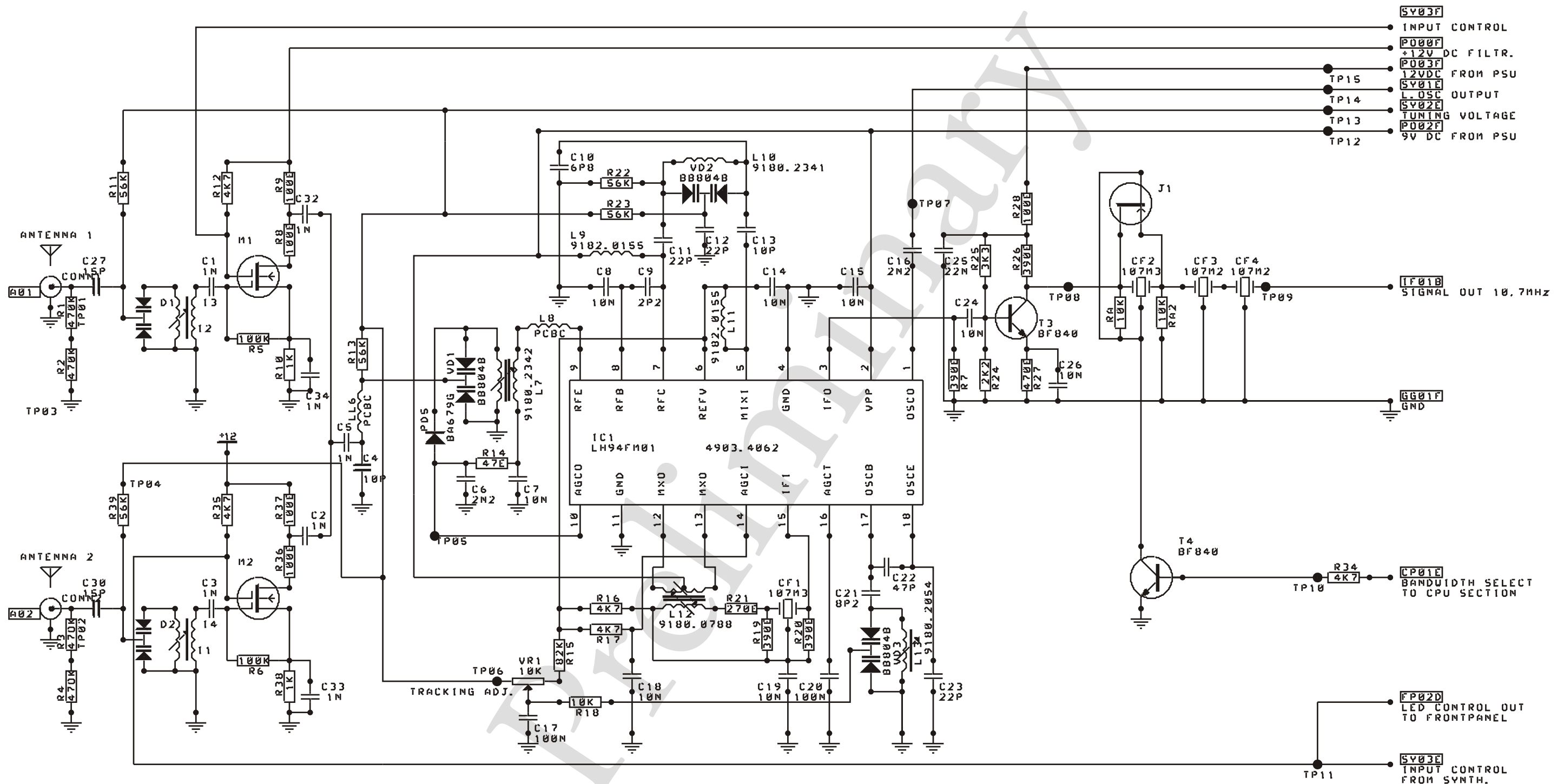

- 5V03F INPUT CONTROL
- P000F +12V DC FILTR.
- P003F 12VDC FROM PSU
- 5V01E L OSC OUTPUT
- 5V02E TUNING VOLTAGE
- P002F 9V DC FROM PSU

1F01B SIGNAL OUT 10.7MHz

6G01F GND

CP01E BANDWIDTH SELECT TO CPU SECTION

FP02D LED CONTROL OUT TO FRONTPANEL

5V03E INPUT CONTROL FROM SYNTH.

Title		
TUNER FRONTEND AND IF-PRESTAGE		
Size	Number	Revision
A3	NAD040_02_03	2.0
Date:	17-OCT 2000	Sheet 2 of 34
File:	E:\SCH\040_0203\1	Drawn By: KIRALY

NAD S400 MAIN BOARD

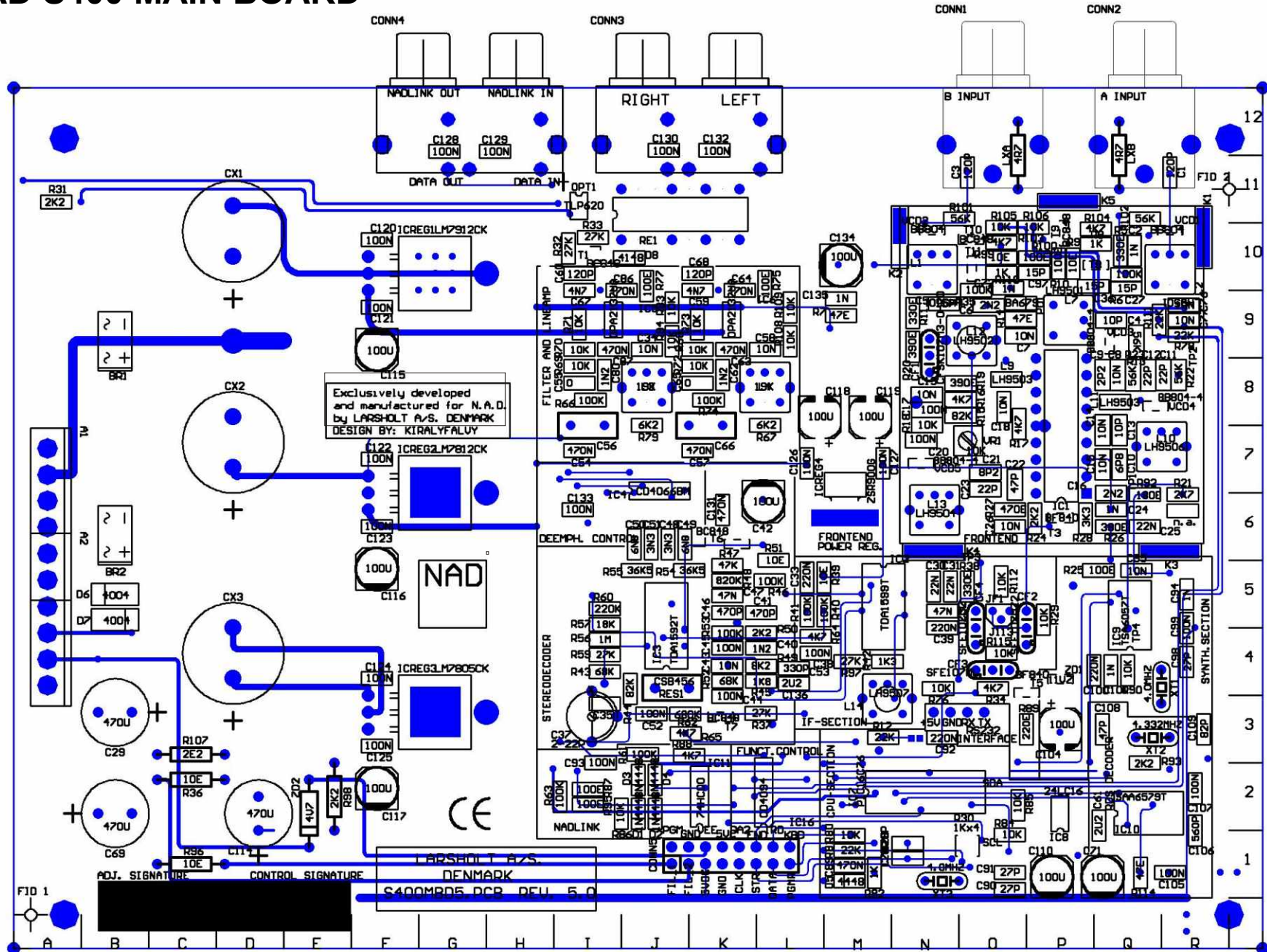

NAD S400 POWER BOARD

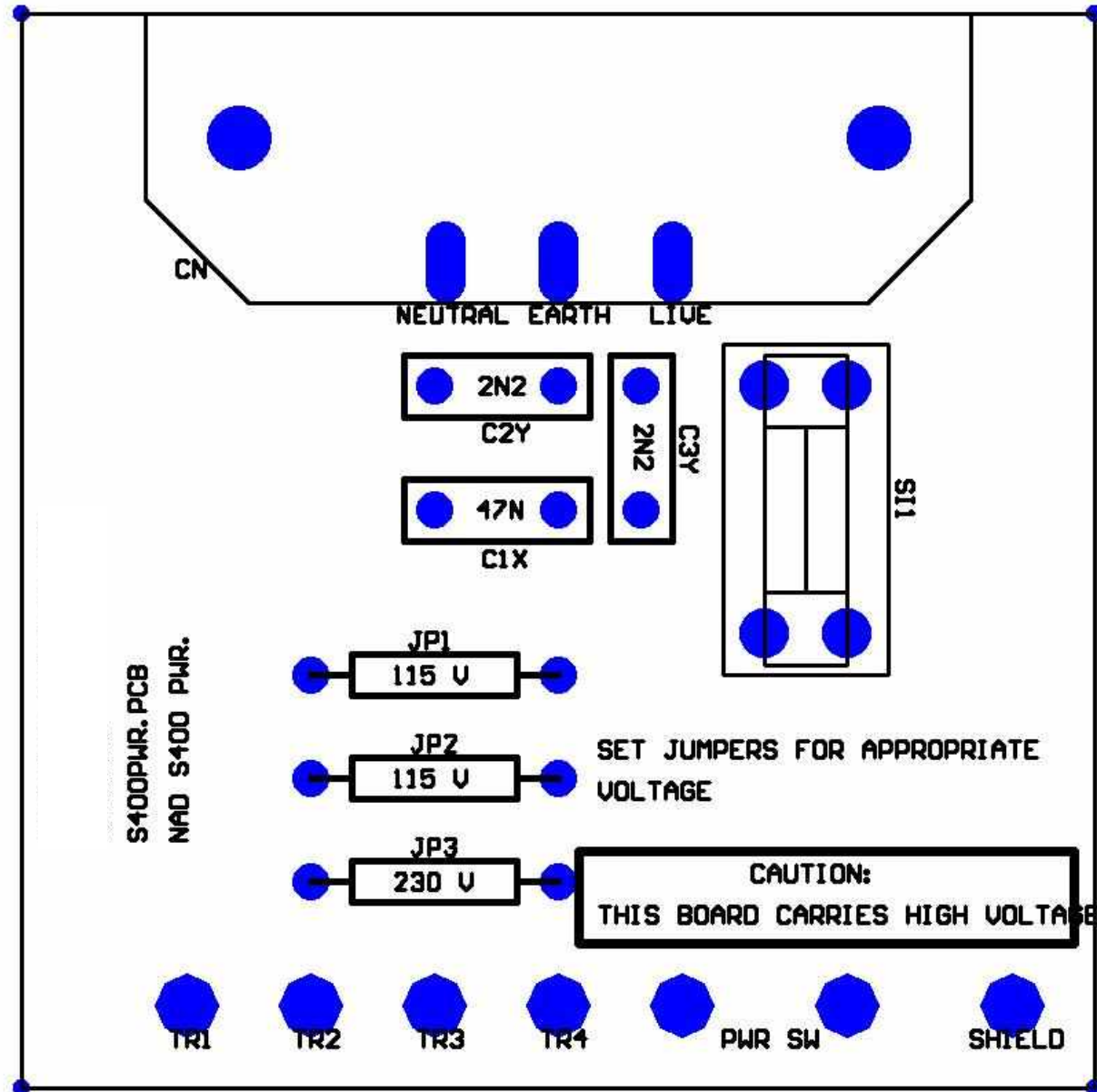

NAD S400 POWER BOARD

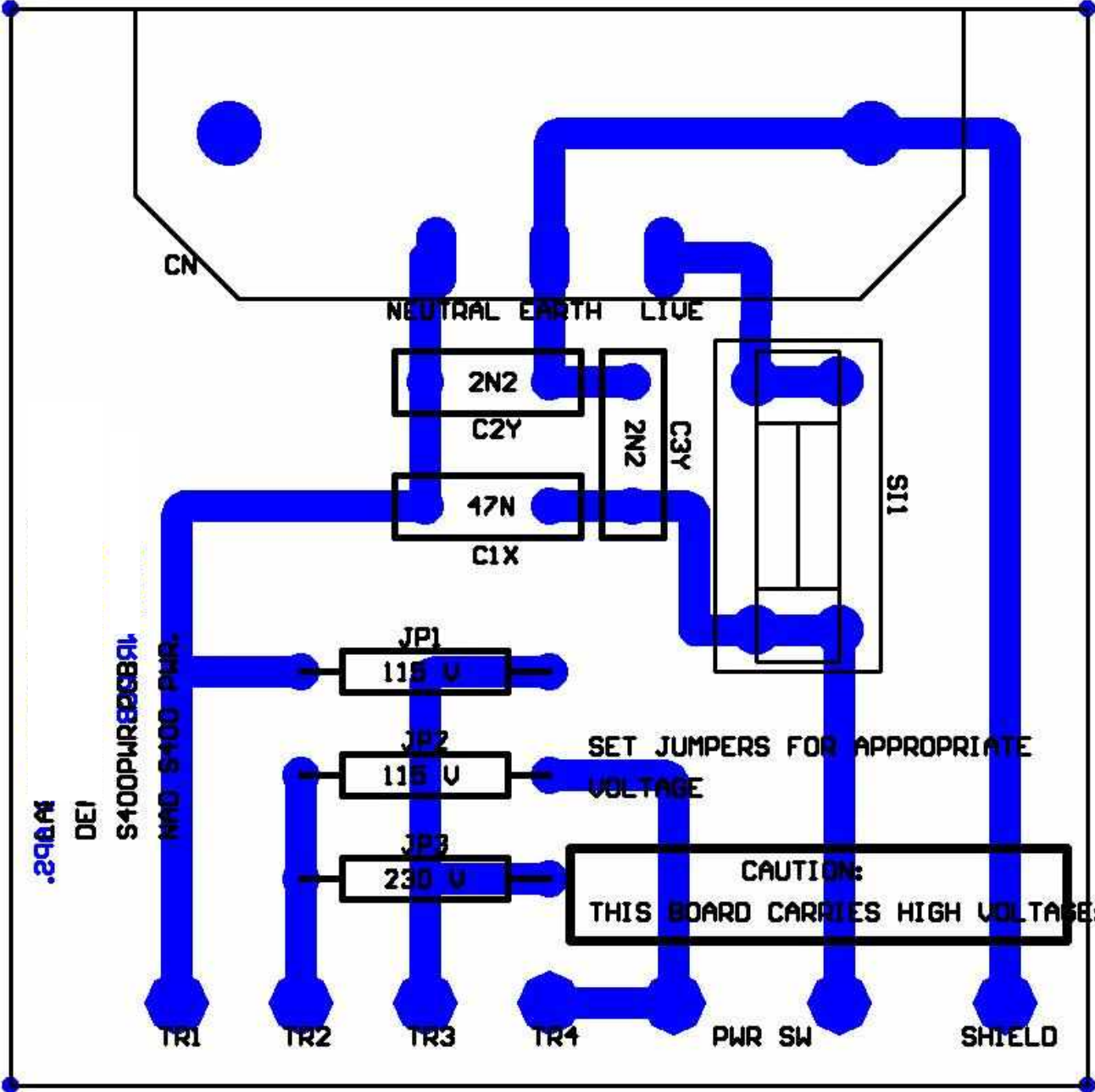

NAD S400 SUB DISPLAY BOARD

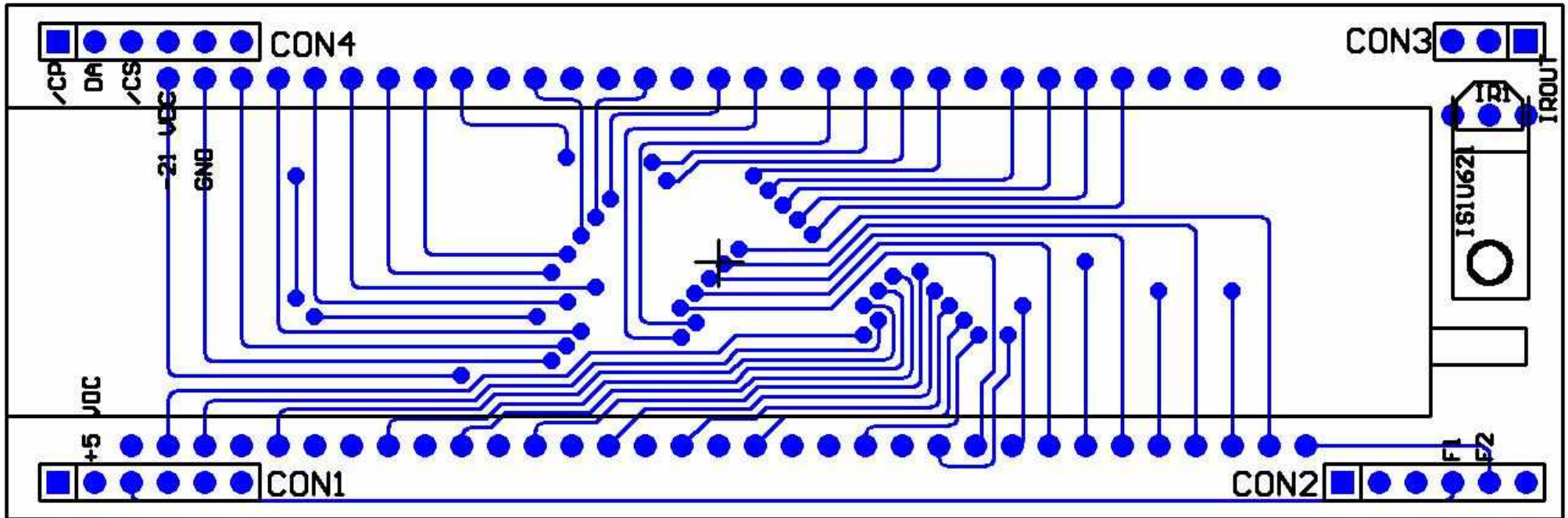

NAD S400 SUB DISPLAY BOARD

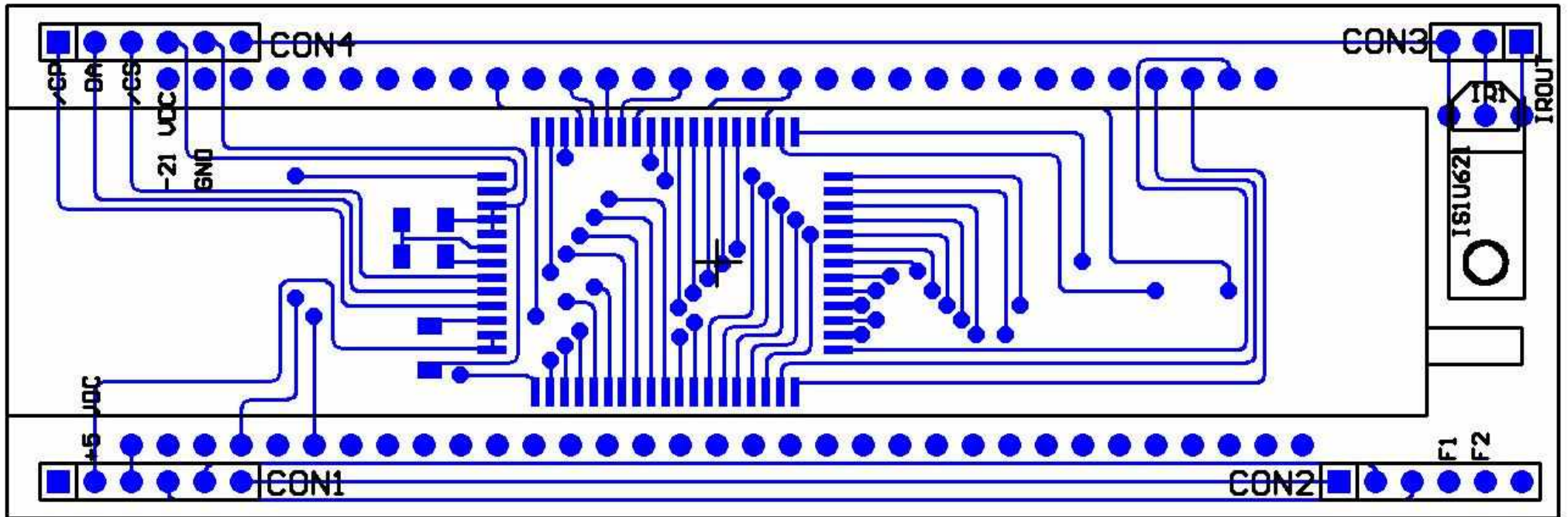

NAD S400 MAIN DISPLAY BOARD

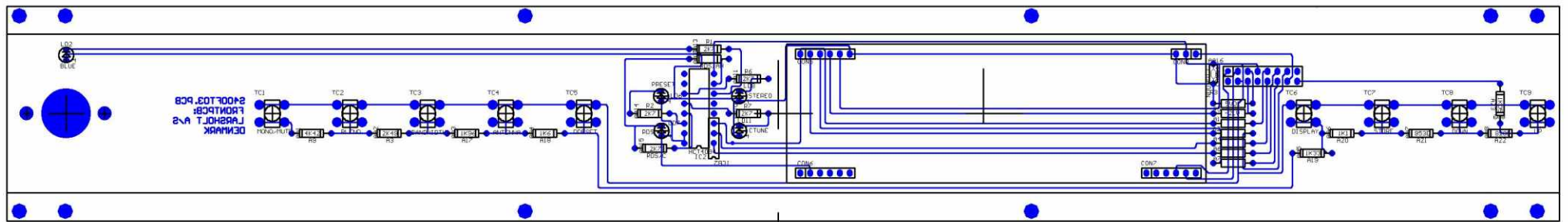

NAD S400 MAIN DISPLAY BOARD

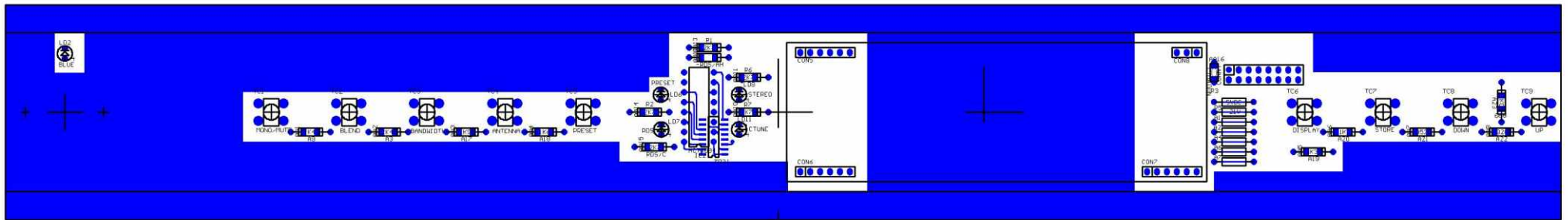

ELECTRICAL PARTSLIST
MOTHERBOARD

VALUE	DESIGNATOR	FOOTPRINT	MANUFACT P.N.	MANUFACTURER	COOR X	COOR Y
100E	R10	1206 SMD	MCR18F1000	ROHM	6390	4160
100E	R100	1206 SMD	MCR18F1000	ROHM	6245	4195
100E	R28	1206 SMD	MCR18F1000	ROHM	6625	2340
100E	R75	1206 SMD	MCR18F1000	ROHM	4650	4025
100E	R77	1206 SMD	MCR18F1000	ROHM	3950	4025
100E	R87	1206 SMD	MCR18F1000	ROHM	3600	1045
100E	R95	1206 SMD	MCR18F1000	ROHM	3600	955
100K	R35	1206 SMD	RC06A104JT	YAGEO	5900	4000
100K	R40	1206 SMD	RC06A104JT	YAGEO	5000	2100
100K	R41	1206 SMD	RC06A104JT	YAGEO	4900	2100
100K	R46	1206 SMD	RC06A104JT	YAGEO	4676	2280
100K	R53	1206 SMD	RC06A104JT	YAGEO	4426	1970
100K	R6	1206 SMD	RC06A104JT	YAGEO	6790	4095
100K	R61	1206 SMD	RC06A104JT	YAGEO	3925	1250
100K	R63	1206 SMD	RC06A104JT	YAGEO	3435	1000
100K	R66	1206 SMD	RC06A104JT	YAGEO	3615	3350
100K	R74	1206 SMD	RC06A104JT	YAGEO	4315	3350
100N	C105	1206 SMD	MCH315C104K	ROHM	7050	550
100N	C107	1206 SMD	MCH315C104K	ROHM	7200	1050
100N	C120	1206 SMD	MCH315C104K	ROHM	2350	4300
100N	C121	1206 SMD	MCH315C104K	ROHM	2350	3900
100N	C122	1206 SMD	MCH315C104K	ROHM	2350	3000
100N	C123	1206 SMD	MCH315C104K	ROHM	2350	2600
100N	C124	1206 SMD	MCH315C104K	ROHM	2350	1700
100N	C125	1206 SMD	MCH315C104K	ROHM	2350	1300
100N	C126	1206 SMD	MCH315C104K	ROHM	4900	2975
100N	C127	1206 SMD	MCH315C104K	ROHM	5350	2975
100N	C128	1206 SMD	MCH315C104K	ROHM	2750	4825
100N	C129	1206 SMD	MCH315C104K	ROHM	3050	4825
100N	C130	1206 SMD	MCH315C104K	ROHM	4050	4830
100N	C132	1206 SMD	MCH315C104K	ROHM	4350	4830
100N	C133	1206 SMD	MCH315C104K	ROHM	3540	2700
100N	C20	1206 SMD	MCH315C104K	ROHM	5574	3114
100N	C38	1206 SMD	MCH315C104K	ROHM	4950	1850
100N	C44	1206 SMD	MCH315C104K	ROHM	4426	1595
100N	C45	1206 SMD	MCH315C104K	ROHM	4426	1880
100N	C52	1206 SMD	MCH315C104K	ROHM	3976	1490
100N	C93	1206 SMD	MCH315C104K	ROHM	3675	1200
100N	C99	1206 SMD	MCH315C104K	ROHM	7150	2000
100U	C104	SMDELKO6.3	NACE100M16V	NIC COMP.	6400	1400
100U	C110	SMDELKO6.3	NACE100M16V	NIC COMP.	6350	525
100U	C115	SMDELKO6.3	NACE100M16V	NIC COMP.	2350	3650
100U	C116	SMDELKO6.3	NACE100M16V	NIC COMP.	2350	2350
100U	C117	SMDELKO6.3	NACE100M16V	NIC COMP.	2350	1050
100U	C118	SMDELKO6.3	NACE100M16V	NIC COMP.	4975	3250
100U	C119	SMDELKO6.3	NACE100M16V	NIC COMP.	5275	3250
100U	C134	SMDELKO6.3	NACE100M16V	NIC COMP.	5100	4150
100U	C42	SMDELKO6.3	NACE100M16V	NIC COMP.	4640	2750
100U	C71	SMDELKO6.3	NACE100M16V	NIC COMP.	6650	525
10E	R36	AXIAL0.5	RC06A100JT	YAGEO	1000	1100
10E	R39	1206 SMD	RC06A100JT	YAGEO	5000	2300
10E	R51	1206 SMD	RC06A100JT	YAGEO	4700	2400
10E	R9	1206 SMD	RC06A100JT	YAGEO	6475	4160
10E	R96	AXIAL0.5	RC06A100JT	YAGEO	1000	600
10E	R99	1206 SMD	RC06A100JT	YAGEO	6050	4195
10E	R21	1206 SMD	RC06A100JT	YAGEO	7125	2790
10K	R105	1206 SMD	MCR18F1002	ROHM	6050	4375
10K	R106	1206 SMD	MCR18F1002	ROHM	6240	4375
10K	R108	1206 SMD	MCR18F1002	ROHM	4800	3700
10K	R109	1206 SMD	MCR18F1002	ROHM	4800	3900
10K	R112	1206 SMD	MCR18F1002	ROHM	6050	2275
10K	R115	1206 SMD	MCR18F1002	ROHM	6050	1850

VALUE	DESIGNATOR	FOOTPRINT	MANUFACT P.N.	MANUFACTURER	COOR X	COOR Y
10K	R18	1206 SMD	MCR18F1002	ROHM	5609	3204
10K	R29	1206 SMD	MCR18F1002	ROHM	6300	2050
10K	R68	1206 SMD	MCR18F1002	ROHM	4250	3650
10K	R69	1206 SMD	MCR18F1002	ROHM	3550	3550
10K	R70	1206 SMD	MCR18F1002	ROHM	3550	3650
10K	R71	1206 SMD	MCR18F1002	ROHM	3550	3800
10K	R72	1206 SMD	MCR18F1002	ROHM	4250	3550
10K	R73	1206 SMD	MCR18F1002	ROHM	4250	3800
10K	R76	1206 SMD	MCR18F1002	ROHM	5675	1640
10K	R80	1206 SMD	MCR18F1002	ROHM	5150	770
10K	R83	1206 SMD	MCR18F1002	ROHM	4100	3900
10K	R84	1206 SMD	MCR18F1002	ROHM	6100	775
10K	R85	1206 SMD	MCR18F1002	ROHM	6150	950
10K	R86	1206 SMD	MCR18F1002	ROHM	3800	900
10K	R90	1206 SMD	MCR18F1002	ROHM	6800	1750
10K	R94	1206 SMD	MCR18F1002	ROHM	4100	3700
10K	VR1	ST4TRIM	3314G103J	BOURNS	5964	3064
10N	C14	1206 SMD	MCH315C103K	ROHM	6649	3174
10N	C15	1206 SMD	MCH315C103K	ROHM	6649	2969
10N	C18	1206 SMD	MCH315C103K	ROHM	6064	3309
10N	C19	1206 SMD	MCH315C103K	ROHM	5609	3384
10N	C26	1206 SMD	MCH315C103K	ROHM	6100	2600
10N	C34	1206 SMD	MCH315C103K	ROHM	3950	3650
10N	C43	1206 SMD	MCH315C103K	ROHM	4425	1775
10N	C58	1206 SMD	MCH315C103K	ROHM	4650	3650
10N	C7	1206 SMD	MCH315C103K	ROHM	6165	3730
10N	C76	1206 SMD	MCH315C103K	ROHM	7130	3915
10N	C77	1206 SMD	MCH315C103K	ROHM	7130	3825
10N	C8	1206 SMD	MCH315C103K	ROHM	6739	3499
10N	C95	1206 SMD	MCH315C103K	ROHM	6850	2340
10P	C13	1206 SMD	MCH315A100D	ROHM	6749	3174
10P	C4	1206 SMD	MCH315A100D	ROHM	6699	3824
11VZ	ZD1	SOT23	BZX84C11-215	PHILIPS	6400	1700
120P	C60	1206 SMD	MCH315A121J	ROHM	3550	4100
120P	C68	1206 SMD	MCH315A121J	ROHM	4250	4100
120P	C1	1206 SMD	MCH315C102K	ROHM	7050	4700
120P	C3	1206 SMD	MCH315C102K	ROHM	5850	4700
120P	C28	1206 SMD	MCH315A270J	ROHM	5495	735
120P	C70	1206 SMD	MCH315A270J	ROHM	5495	645
15P	C27	1206 SMD	MCH315A150J	ROHM	6790	4010
15P	C36	1206 SMD	MCH315A150J	ROHM	6595	4025
15P	C5	1206 SMD	MCH315A150J	ROHM	5710	3920
15P	C97	1206 SMD	MCH315A150J	ROHM	6245	4105
180E	R92	1206 SMD	RC06A181JT	YAGEO	6900	2790
18K	R57	1206 SMD	RC06A183JT	YAGEO	3700	2020
19KA5305BX	L3	7PL	19KA5305BX	LARSHOLT	3950	3425
19KA5305BX	L4	7PL	19KA5305BX	LARSHOLT	4650	3425
1K	R110	1206 SMD	RC06A102JT	YAGEO	6050	4105
1K	R8	1206 SMD	RC06A102JT	YAGEO	6610	4275
1K	R82	1206 SMD	RC06A102JT	YAGEO	5300	550
1K X4	R30	ARC241	1K0X4ARC241	PHILIPS	5825	700
1K3	R42	1206 SMD	MCR18F1301	ROHM	5375	1800
1K8	R45	1206 SMD	MCR18F1801	ROHM	4626	1685
1M	R56	1206 SMD	RC06A564JT	YAGEO	3700	1930
1N	C101	1206 SMD	MCH315C102K	ROHM	6700	1750
1N	C135	1206 SMD	MCH315C102K	ROHM	5100	3950
1N	C17	1206 SMD	MCH315C102K	ROHM	5609	3294
1N	C2	1206 SMD	MCH315C102K	ROHM	6840	4235
1N	C24	1206 SMD	MCH315C102K	ROHM	6700	2700
1N	C72	1206 SMD	MCH315C102K	ROHM	6090	4015
1N	C94	1206 SMD	MCH315C102K	ROHM	7150	2200
1N2	C40	1206 SMD	MCH315C122K	ROHM	4626	1880
1N2	C62	1206 SMD	MCH315C122K	ROHM	4400	3500
1N2	C80	1206 SMD	MCH315C122K	PHILIPS	3700	3500
1N4004	D6	SM-DIODE	1N4004	PHILIPS	800	2200
1N4004	D7	SM-DIODE	1N4004	PHILIPS	800	2050
1N4448	D1	1206 SMD	1N4448	PHILIPS	3900	900

VALUE	DESIGNATOR	FOOTPRINT	MANUFACT P. N.	MANUFACTURER	COOR X	COOR Y
1N4448	D2	1206 SMD	1N4448	PHILIPS	4000	900
1N4448	D3	1206 SMD	1N4448	PHILIPS	3900	1100
1N4448	D4	1206 SMD	1N4448	PHILIPS	4000	1100
1N4448	D5	1206 SMD	1N4448	PHILIPS	5150	500
1N4448	D8	1206 SMD	1N4448	PHILIPS	3845	4195
2200U	C111	ELKO4M/10M	CLP2200AB35	DUBILIER	1500	4350
2200U	C112	ELKO4M/10M	CLP2200AB35	DUBILIER	1500	3100
2200U	C113	ELKO4M/10M	CLP2200AB35	DUBILIER	1500	1850
220E	R89	1206 SMD	RC06A221JT	YAGEO	6200	1400
220K	R60	1206 SMD	RC06A224JT	YAGEO	3700	2115
220N	C100	1206 SMD	MCH315F224Z	ROHM	6600	1750
220N	C33	1206 SMD	MCH315F224Z	ROHM	4900	2300
220N	C39	1206 SMD	MCH315F224Z	ROHM	5700	2000
220N	C92	1206 SMD	MCH315F224Z	ROHM	5700	1350
2-22P	C37	VARCAP75	222280811229A	PHILIPS	3625	1325
22K	R111	1206 SMD	RC06A223JT	YAGEO	6985	3825
22K	R12	1206 SMD	RC06A223JT	YAGEO	5350	1350
22K	R78	1206 SMD	RC06A223JT	YAGEO	7130	3735
22K	R81	1206 SMD	RC06A223JT	YAGEO	5150	680
22N	C25	1206 SMD	MCH315C223K	ROHM	6900	2600
22N	C30	1206 SMD	MCH315C223K	ROHM	5650	2245
22N	C31	1206 SMD	MCH315C223K	ROHM	5750	2245
22P	C11	1206 SMD	MCH315A220J	ROHM	7009	3499
22P	C12	1206 SMD	MCH315A220J	ROHM	6919	3499
22P	C23	1206 SMD	MCH315A220J	ROHM	5954	2824
24LC16	IC8	SMD08	24LC16	SGS	6400	900
27K	R37	1206 SMD	MCR18F2702	ROHM	4625	1495
27K	R59	1206 SMD	MCR18F2702	ROHM	3700	1840
27K	R97	1206 SMD	MCR18F2702	ROHM	5150	1800
27K	R32	1206 SMD	RC06A273JT	YAGEO	3625	4540
27K	R33	1206 SMD	RC06A273JT	YAGEO	3625	4630
27P	C90	1206 SMD	MCH315A270J	ROHM	6100	450
27P	C91	1206 SMD	MCH315A270J	ROHM	6100	550
27P	C98	1206 SMD	MCH315A270J	ROHM	7150	1800
2K2	R24	1206 SMD	RC06A222JT	YAGEO	6250	2650
2K2	R50	1206 SMD	RC06A222JT	YAGEO	4626	1970
2K2	R93	1206 SMD	RC06A222JT	YAGEO	6900	1200
2K2	R98	AXIAL0.5	RC06A222JT	YAGEO	2100	1200
2K2	R31	1206 SMD	RC06A222JT	YAGEO	3625	4450
2N2	C16	1206 SMD	MCH315C222K	ROHM	6700	2800
2N2	C6	1206 SMD	MCH315C222K	ROHM	5975	3910
2P2	C9	1206 SMD	MCH315A2R2C	ROHM	6649	3499
2R2	R107	AXIAL0.5	2R2	PHILIPS	1000	1250
2U2	C136	1206 SMD	2U2	MURATA	4820	1670
2U2	C61	1206 SMD	2U2	MURATA	6630	830
330E	R11	1206 SMD	MCR18F3300	ROHM	5525	3865
330E	R38	1206 SMD	MCR18F3300	ROHM	5850	2245
330E	R5	1206 SMD	MCR18F3300	ROHM	6755	4235
330P	C53	1206 SMD	MCH315A331J	ROHM	4820	1760
36K5	R54	1206 SMD	MCR18F3652	ROHM	4200	2340
36K5	R55	1206 SMD	MCR18F3652	ROHM	3890	2340
390E	R19	1206 SMD	MCR18F3900	ROHM	5809	3449
390E	R20	1206 SMD	MCR18F3900	ROHM	5525	3665
390E	R26	1206 SMD	MCR18F3900	ROHM	6700	2600
3K3	R25	1206 SMD	RC06A332JT	YAGEO	6550	2650
3N3	C48	1206 SMD	MCH315C332K	ROHM	4075	2495
3N3	C51	1206 SMD	MCH315C332K	ROHM	3975	2495
4.0MHZ	XT1	XTALV	4.0MHz	TXC	7000	1550
4.0MHZ	XT3	XTALV	4.0MHz	TXC	5600	500
4.332MHZ	XT2	XTALV	4.332MHZ	TXC	7050	1350
470E	R27	1206 SMD	RC06A471JT	YAGEO	6100	2700
470N	C131	1206 SMD	MCH312F474Z	ROHM	4400	2700
470N	C54	1206 SMD	MCH312F474Z	ROHM	3550	3050
470N	C57	1206 SMD	MCH312F474Z	ROHM	4250	3050
470N	C63	1206 SMD	MCH312F474Z	ROHM	4450	3650
470N	C64	1206 SMD	MCH312F474Z	ROHM	4500	4000
470N	C86	1206 SMD	MCH312F474Z	ROHM	3800	4000

VALUE	DESIGNATOR	FOOTPRINT	MANUFACT P. N.	MANUFACTURER	COOR X	COOR Y
470N	C87	1206 SMD	MCH312F474Z	ROHM	3750	3650
470N	C89	1206 SMD	MCH312F474Z	ROHM	5150	590
470P	C41	1206 SMD	MCH315A471J	ROHM	4626	2090
470P	C46	1206 SMD	MCH315A471J	ROHM	4426	2090
470U	C114	RB.2/.4	2222 037 50471	PHILIPS	1650	800
470U	C29	RB.2/.4	2222 037 50471	PHILIPS	900	1500
470U	C69	RB.2/.4	2222 037 50471	PHILIPS	700	900
47E	R114	1206 SMD	RC06A470JT	YAGEO	6875	550
47E	R14	1206 SMD	RC06A470JT	YAGEO	6165	3830
47E	R7	1206 SMD	RC06A470JT	YAGEO	5100	3850
47K	R47	1206 SMD	RC06A473JT	YAGEO	4426	2370
47N	C32	1206 SMD	MCH315C473K	ROHM	5700	2100
47N	C47	1206 SMD	MCH315C473K	ROHM	4426	2190
47P	C108	1206 SMD	MCH315A470J	ROHM	6650	1400
47P	C22	1206 SMD	MCH315A470J	ROHM	6129	2849
4K7	R103	1206 SMD	RC06A472JT	YAGEO	6050	4285
4K7	R104	1206 SMD	RC06A472JT	YAGEO	6610	4365
4K7	R16	1206 SMD	RC06A472JT	YAGEO	5809	3354
4K7	R17	1206 SMD	RC06A472JT	YAGEO	6154	3209
4K7	R34	1206 SMD	RC06A472JT	YAGEO	6000	1640
4K7	R62	1206 SMD	RC06A472JT	YAGEO	4180	1375
4K7	R64	1206 SMD	RC06A472JT	YAGEO	4950	1950
4K7	R88	1206 SMD	RC06A472JT	YAGEO	4200	1245
4N7	C59	1206 SMD	MCH315C472K	ROHM	4250	4000
4N7	C67	1206 SMD	MCH315C472K	ROHM	3550	4000
4R7K	LXA	.4 AX	ALA0410-4R7K-T52-T/I LARSHOLT		6150	4800
4R7K	LXB	.4 AX	ALA0410-4R7K-T52-T/I LARSHOLT		6750	4800
4V7	ZD2	DIODE0.4	BZX84C4V7	PHILIPS	1950	1100
560P	C106	1206 SMD	MCH315A561J	ROHM	7200	800
56K	R101	1206 SMD	RC06A563JT	YAGEO	5800	4425
56K	R102	1206 SMD	RC06A563JT	YAGEO	6900	4425
56K	R13	1206 SMD	RC06A563JT	YAGEO	6850	3700
56K	R22	1206 SMD	RC06A563JT	YAGEO	7099	3499
56K	R23	1206 SMD	RC06A563JT	YAGEO	6829	3499
680K	R65	1206 SMD	RC06A684JT	YAGEO	4176	1490
68K	R43	1206 SMD	RC06A683JT	YAGEO	3700	1740
68K	R52	1206 SMD	RC06A683JT	YAGEO	4426	1685
6K2	R67	1206 SMD	MCR18F6201	ROHM	4650	3200
6K2	R79	1206 SMD	MCR18F6201	ROHM	3950	3200
6N8	C49	1206 SMD	MCH315C682K	ROHM	4175	2495
6N8	C50	1206 SMD	MCH315C682K	ROHM	3875	2495
6P8	C10	1206 SMD	MCH315A6R8C	ROHM	6749	2969
74HC00	IC11	SMD14A	74HC00	PHILIPS	4375	850
820K	R48	1206 SMD	RC06A824JT	YAGEO	4426	2280
82K	R15	1206 SMD	RC06A823JT	YAGEO	5809	3259
82K	R44	1206 SMD	RC06A823JT	YAGEO	3851	1640
82P	C109	1206 SMD	MCH315A820J	ROHM	7250	1400
8K2	R49	1206 SMD	MCR18F8201	ROHM	4626	1775
8P2	C21	1206 SMD	MCH315A8R2C	ROHM	5954	2924
B40S	BR1	SMDBRO	B40S	DIOTEC	800	3700
B40S	BR2	SMDBRO	B40S	DIOTEC	800	2550
BA679	PD1	1206 SMD	BA679G	TEMIC	6165	3925
BB804-4	VCD1	SOT23	BB804-4	TEMIC	7050	4360
BB804-4	VCD2	SOT23	BB804-4	TEMIC	5640	4360
BB804-4	VCD3	SOT23	BB804-4	TEMIC	6694	3699
BB804-4	VCD4	SOT23	BB804-4	TEMIC	6964	3319
BB804-4	VCD5	SOT23	BB804-4	TEMIC	5574	2979
BC848	T1	SOT23	BC848	PHILIPS	3625	4325
BC848	T10	SOT23	BC848	PHILIPS	5870	4300
BC848	T6	SOT23	BC848	PHILIPS	4485	2495
BC848	T7	SOT23	BC848	PHILIPS	4386	1470
BC848	T9	SOT23	BC848	PHILIPS	6425	4340
BF840	T3	SOT23	BF840	PHILIPS	6400	2650
BF840	T5	SOT23	BF840	PHILIPS	6200	1620
BF996	T11	SOT143	BF996	PHILIPS	5875	4130
BF996	T8	SOT143	BF996	PHILIPS	6610	4150
C1016007	CONN1	PALCON	C1016007	LARSHOLT	6000	5200

VALUE	DESIGNATOR	FOOTPRINT	MANUFACT P.N.	MANUFACTURER	COOR X	COOR Y
C1016007	CONN2	PALCON	C1016007	LARSHOLT	6900	5200
CD4066BM	IC4	SMD14A	HEF4066BM	PHILIPS	3875	2700
CD4094	IC16	SMD16A	HEF4094	PHILIPS	4645	1025
CFSK107M3-0-20	CF1	CERFILTER	CFSK107M3-0-20	TOKO	5625	3515
CSB456	RES1	RAD0.2	CSB456	TOKO	4000	1645
RY24W-K	RE1	DIP16	RY24W-K	TAKAMISAWA	3800	4300
J113	JF1	TO-92A	J113	LARSHOLT	6000	2100
LH9501	L7	7PL	LH9501	LARSHOLT	6449	3824
LH9501	L1	7PL	LH9501	LARSHOLT	5640	4125
LH9501	L2	7PL	LH9501	LARSHOLT	7050	4125
LH9502	L12	7PL	LH9502	LARSHOLT	5874	3704
LH9503	L11	1206 SMD	LH9503	LARSHOLT	6724	3339
LH9503	L9	1206 SMD	LH9503	LARSHOLT	6079	3474
LH9504	L13	7PL	LH9504	LARSHOLT	5654	2699
LH9506	L10	7PL	LH9506	LARSHOLT	6999	3074
LH9507	L14	7PL	LH9507	LARSHOLT	5375	1580
LM7805CK	ICREG3	D2-HOUSING	LM7805CK	NATIONAL	2700	1500
LM7812CK	ICREG2	D2-HOUSING	LM7812CK	NATIONAL	2700	2800
LM7912CK	ICREG1	D2-HOUSING	LM7912CK	NATIONAL	2700	4100
METAL-CAN	7256-CAN	7256-CAN	7256-CAN	LARSHOLT	XX	XX
OPA2132UA	IC5	SMD08	OPA2132UA	BURR-BROWN	3750	3825
OPA2132UA	IC6	SMD08	OPA2132UA	BURR-BROWN	4450	3825
PCB	PCB	PCB	S400MBD5.PCB	LARSHOLT	XX	XX
PIC16C76	IC7	SMD28	PIC16C76	MICROCHIP	5600	1025
SFE107ML	CF3	CERFILTER	SFE107ML	MURATA	5900	1750
SFE107ML	CF4	CERFILTER	SFE107ML	MURATA	5900	1900
SFE107MZ2	CF2	CERFILTER	SFE107MZ2	MURATA	6200	1900
SAA6579T	IC10	SMD16B	SAA6579T	PHILIPS	6750	715
TDA1592T	IC3	SMD20	TDA1592T	PHILIPS	4066	2015
TDA1599T	IC2	SMD20	TDA1599T	PHILIPS	5165	2350
TLP622	OPT1	SMD OPTO	TLP622	TOSHIBA	3550	4500
TSA6057T	IC9	SMD16B	TSA6057T	PHILIPS	7000	1900
U4062B	IC1	DIP18	U4062B	LARSHOLT	6554	2799
W8816	CONN5	IDC16	W8816	WINSLOW	4100	600
YKC21/3271	CONN3	YKC21	YKC21/3271	JALCO	4200	5210
YKC21/3271	CONN4	YKC21	YKC21/3271	JALCO	2900	5210
ZSR900G	ICREG4	SOT223	ZSR900G	ZETEX	5125	2850
	K1	SPRING	CAN SPRING	LARSHOLT	7250	4315
	K2	SPRING	CAN SPRING	LARSHOLT	5450	4315
	K3	SPRING	CAN SPRING	LARSHOLT	7050	2450
	K4	SPRING	CAN SPRING	LARSHOLT	5650	2450

**ELECTRICAL PARTSLIST
DISPLAYBOARD**

VALUE	DESIGNATOR	FOOTPRINT	MANUFACT P.N.	MANUFACTURER	COOR X	COOR Y
100P	C1	1206BL		PHILIPS		
470N	C2	1206BL		PHILIPS		
47K	R1	1206BL		PHILIPS		
IS1U621	IR1	TO92T	IS1U621	TEMIC		
MSC7128-01	IC1	FP-64	MSC7128-01	OKI		
3P HEADER	CN1	SIL3		WINSLOW		
6P HEADER	CN2	SIP6		WINSLOW		
6P HEADER	CN3	SIP6		WINSLOW		
6P HEADER	CN4	SIP6		WINSLOW		
S400-DISPLAY	400-DISPLAY	PCBLH98DI02.PCB		LARSHOLT		
DM1615C	VFD16	VFDGLASS	DM1615C	ITRON/NORITAKE		

**ELECTRICAL PARTSLIST
DISPLAYBOARD**

VALUE	DESIGNATOR	FOOTPRINT	MANUFACT P.N.	MANUFACTURER	COOR X	COOR Y
S400FT03.PCB	PCB	PCB	S400FT03.PCB	LARSHOLT		
BLUE LED	LED1	LED	RT3-6134-B2S-B	RODAN		
BLUE LED	LED2	LED	RT3-6134-B2S-B	RODAN		
BLUE LED	LED3	LED	RT3-6134-B2S-B	RODAN		
BLUE LED	LED4	LED	RT3-6134-B2S-B	RODAN		
BLUE LED	LED5	LED	RT3-6134-B2S-B	RODAN		
HEF4094BP	IC1	DIP16	HEF4094BP	PHILIPS		
100N	C1	CERCAP2	R15Z104M1HH5-6	CANTEC		
4K42	R1	AXIAL0.4	4K42	PHILIPS		
2K49	R2	AXIAL0.4	2K49	PHILIPS		
1K96	R3	AXIAL0.4	1K96	PHILIPS		
1K6	R4	AXIAL0.4	1K6	PHILIPS		
1K33	R5	AXIAL0.4	1K33	PHILIPS		
1K1	R6	AXIAL0.4	1K1	PHILIPS		
953E	R7	AXIAL0.4	953E	PHILIPS		
820E	R8	AXIAL0.4	820E	PHILIPS		
1K05	R9	AXIAL0.4	1K05	PHILIPS		
2K7	R10	AXIAL0.4	2K7	PHILIPS		
2K7	R11	AXIAL0.4	2K7	PHILIPS		
2K7	R12	AXIAL0.4	2K7	PHILIPS		
2K7	R13	AXIAL0.4	2K7	PHILIPS		
2K7	R14	AXIAL0.4	2K7	PHILIPS		
2X8P HEADER	CONN5	IDC16	W8816	WINSLOW		
MSW1	SW1	POWERSWITCH	MS-59-A	YI-WAI		
SDTX-610-N	TS1	TACT6X6	SDTX-610-N	BOURNS		
SDTX-610-N	TS2	TACT6X6	SDTX-610-N	BOURNS		
SDTX-610-N	TS3	TACT6X6	SDTX-610-N	BOURNS		
SDTX-610-N	TS4	TACT6X6	SDTX-610-N	BOURNS		
SDTX-610-N	TS5	TACT6X6	SDTX-610-N	BOURNS		
SDTX-610-N	TS6	TACT6X6	SDTX-610-N	BOURNS		
SDTX-610-N	TS7	TACT6X6	SDTX-610-N	BOURNS		
SDTX-610-N	TS8	TACT6X6	SDTX-610-N	BOURNS		
SDTX-610-N	TS9	TACT6X6	SDTX-610-N	BOURNS		

**ELECTRICAL PARTSLIST
POWERBOARD**

VALUE	DESIGNATOR	FOOTPRINT	MANUFACT P.N.	MANUFACTURER	COOR X	COOR Y
PCB	PCB	PCB	PCB	PCB		
AC-114	CONN1	IEC POWERCONN	AC-114	YI WAI		
0E	J1	AXIAL.4	MR25 0E	PHILIPS		
0E	J2	AXIAL.4	MR25 0E	PHILIPS		
0E	J3	AXIAL.4	MR25 0E	PHILIPS		
.5 AT	FUSE1	FUSE				
Fuseholder	Fuseholder 1					
Fuseholder	Fuseholder 2					
Transformer	T1, T2, T3	Toroid	TI-65578			

EXPLODED VIEW

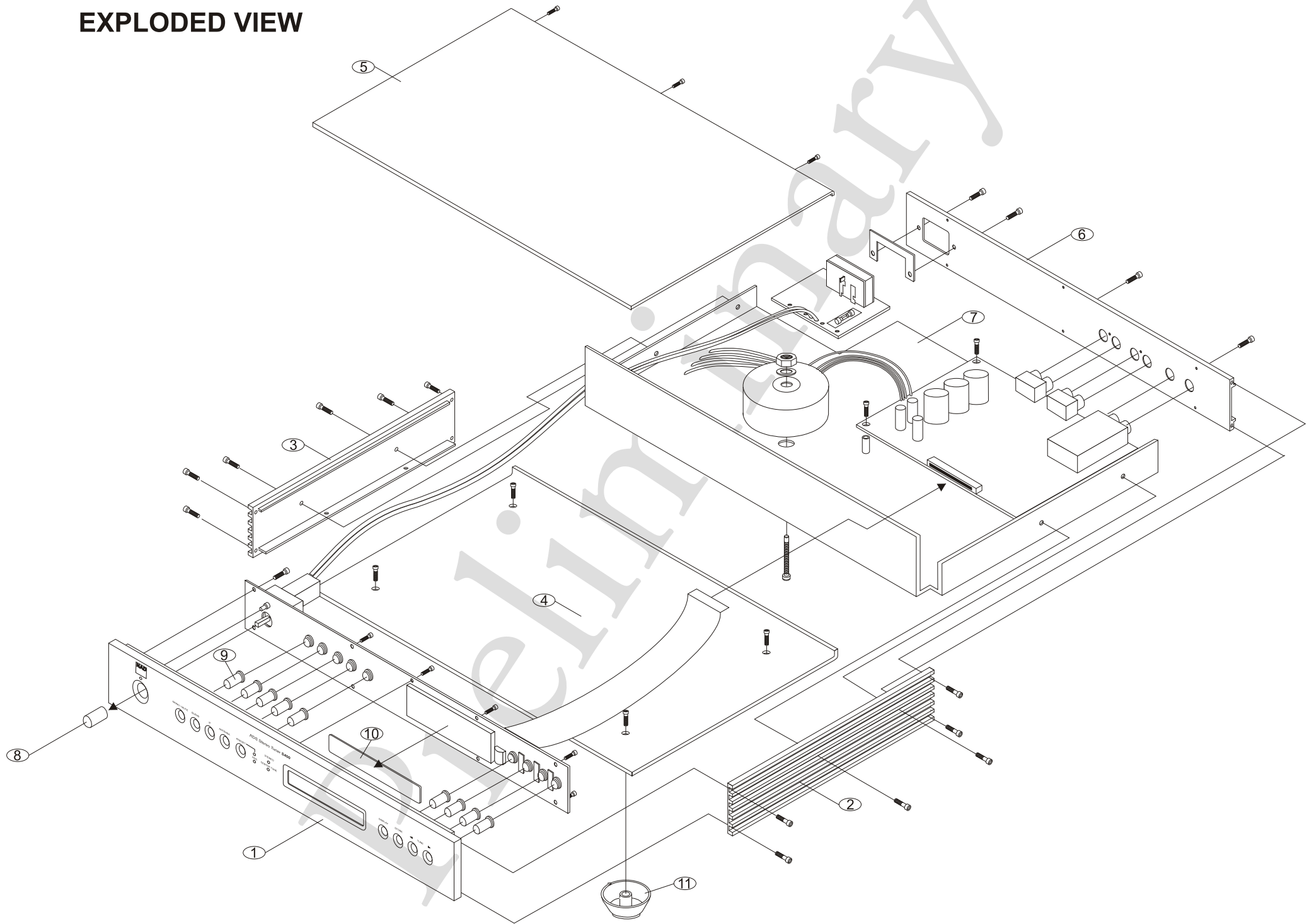

PACKING DIAGRAM

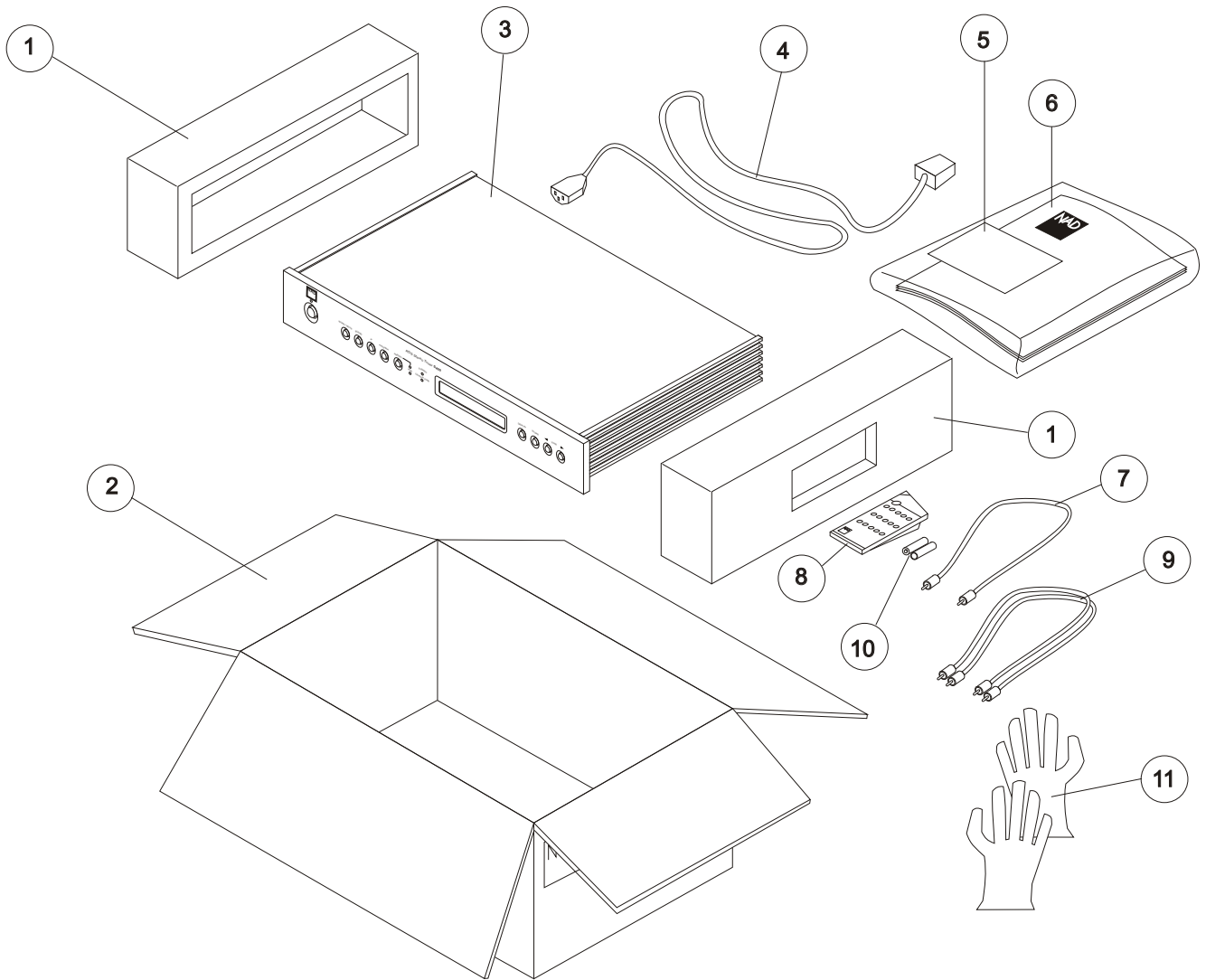

ITEM	PART NUMBER	DESCRIPTION	QTY.
1	S100-2110-A	POLYFOAM	1 SET
2	S100-2210-A	CARTON BOX	1
3	S400	S400	1
4*AH	POW4	POWER CORD NEMA 1-15 POLARIZED	1
4*C	POW2	POWER CORD CEE (7) XVII	1
5	WARR	WARRANTY CARD	1
6	S400-IM	INSTRUCTION MANUAL	1
7	101-000B	NAD LINK CABLE	1
8	RC S400	REMOTE CONTROL HANDSET	1
9	101-000A	AUDIO CABLE	1
10	R03	BATTERIES	1 SET
11	GLOVES	GLOVES	1 SET



SERVICE MANUAL

SERVICE MANUAL

S 400

RDS FM TUNER

S 400

RDS FM TUNER

S 400

RDS FM TUNER



www.nadelectronics.com

© 2003 NAD ELECTRONICS INTERNATIONAL
ONTARIO, CANADA

All rights reserved. No part this publication may be reproduced, stored or transmitted in any form without the written permission of NAD Electronics International