

**T 742**

**SURROUND  
SOUND RECEIVER**

**T 742**

**SURROUND  
SOUND RECEIVER**

**SERVICE MANUAL**



# PRODUCT SAFETY SERVICING GUIDELINES

CAUTION : DO NOT ATTEMPT TO MODIFY THIS PRODUCT IN ANY WAY. NEVER PERFORM CUSTOMIZED INSTALLATIONS WITHOUT MANUFACTURER'S APPROVAL. UNAUTHORIZED MODIFICATIONS WILL NOT ONLY VOID THE WARRANTY, BUT MAY LEAD TO YOUR BEING LIABLE FOR ANY RESULTING PROPERTY DAMAGE OR USER INJURY.

SERVICE WORK SHOULD BE PERFORMED ONLY AFTER YOU ARE THOROUGHLY FAMILIAR WITH ALL OF THE FOLLOWING SAFETY CHECKS AND SERVICING GUIDELINES. TO DO OTHERWISE, INCREASES THE RISK OF POTENTIAL HAZARDS AND INJURY TO THE USER.

WHILE SERVICING, USE AN ISOLATION TRANSFORMER FOR PROTECTION FROM AC LINE SHOCK.

## SAFETY CHECKS

AFTER THE ORIGINAL SERVICE PROBLEM HAS BEEN CORRECTED. A CHECK SHOULD BE MADE OF THE FOLLOWING.

### SUBJECT : FIRE & SHOCK HAZARD

1. BE SURE THAT ALL COMPONENTS ARE POSITIONED IN SUCH A WAY AS TO AVOID POSSIBILITY OF ADJACENT COMPONENT SHORTS. THIS IS ESPECIALLY IMPORTANT ON THOSE MODULES WHICH ARE TRANSPORTED TO AND FROM THE REPAIR SHOP.
2. NEVER RELEASE A REPAIR UNLESS ALL PROTECTIVE DEVICES SUCH AS INSULATORS, BARRIERS, COVERS, SHIELDS, STRAIN RELIEFS, POWER SUPPLY CORDS, AND OTHER HARDWARE HAVE BEEN REINSTALLED PER ORIGINAL DESIGN. BE SURE THAT THE SAFETY PURPOSE OF THE POLARIZED LINE PLUG HAS NOT BEEN DEFEATED.
3. SOLDERING MUST BE INSPECTED TO DISCOVER POSSIBLE COLD SOLDER JOINTS, SOLDER SPLASHES OR SHARP SOLDER POINTS. BE CERTAIN TO REMOVE ALL LOOSE FOREIGN PARTICLES.
4. CHECK FOR PHYSICAL EVIDENCE OF DAMAGE OR DETERIORATION TO PARTS AND COMPONENTS. FOR FRAYED LEADS, DAMAGED INSULATION (INCLUDING AC CORD). AND REPLACE IF NECESSARY FOLLOW ORIGINAL LAYOUT, LEAD LENGTH AND DRESS.
5. NO LEAD OR COMPONENT SHOULD TOUCH A RECEIVING TUBE OR A RESISTOR RATED AT 1 WATT OR MORE. LEAD TENSION AROUND PROTRUDING METAL SURFACES MUST BE AVOIDED.
6. ALL CRITICAL COMPONENTS SUCH AS FUSES, FLAMEPROOF RESISTORS, CAPACITORS, ETC. MUST BE REPLACED WITH EXACT FACTORY TYPES, DO NOT USE REPLACEMENT COMPONENTS OTHER THAN THOSE SPECIFIED OR MAKE UNRECOMMENDED CIRCUIT MODIFICATIONS.
7. AFTER RE-ASSEMBLY OF THE SET ALWAYS PERFORM AN AC LEAKAGE TEST ON ALL EXPOSED METALLIC PARTS OF THE CABINET, (THE CHANNEL SELECTOR KNOB, ANTENNA TERMINALS. HANDLE AND SCREWS) TO BE SURE THE SET IS SAFET TO OPERATE WITHOUT DANGER OF ELECTRICAL SHOCK. DO NOT USE A LINE ISOLATION TRANSFORMER DURING THIS TEST USE AN AC VOLTMETER, HAVING 5000 OHMS PER VOLT OR MORE SENSITIVITY, IN THE FOLLOWING MANNER; CONNECT A 1500 OHM 10 WATT RESISTOR, PARALLELED BY A .15 MFD, 150V AC TYPE CAPACITOR BETWEEN A KNOWN GOOD EARTH GROUND (WATER PIPE, CONDUIT, ETC.) AND THE EXPOSED METALLIC PARTS, ONE AT A TIME.  
MEASURE THE AC VOLTAGE ACROSS THE COMBINATION OF 1500 OHM RESISTOR AND .15 MFD CAPACITOR.  
REVERSE THE AC PLUG AND REPEAT AC VOLTAGE MEASUREMENTS FOR EACH EXPOSED METALLIC PART.

VOLTAGE MEASURE MUST NOT EXCEED 75 VOLTS R.M.S. THIS CORRESPONDS TO 0.5 MILLIAMPER AC ANY VALUE EXCEEDING THIS LIMIT CONSTITUTES A POTENTIAL SHOCK HAZARD AND MUST BE CORRECTED IMMEDIATELY.

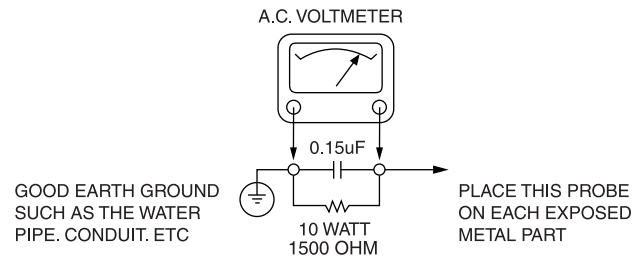

## SUBJECT : GRAPHIC SYMBOLS



THE LIGHTNING FLASH WITH ARROWHEAD SYMBOL, WITHIN AN EQUILATERAL TRIANGLE, IS INTENDED TO ALERT THE USER TO THE PRESENCE OF UNINSULATED "DANGEROUS VOLTAGE" WITHIN THE PRODUCT'S ENCLOSURE THAT MAY BE OF SUFFICIENT MAGNITUDE TO CONSTITUTE A RISK OF ELECTRIC SHOCK.



THE EXCLAMATION POINT WITHIN AN EQUILATERAL TRIANGLE IS INTENDED TO ALERT THE USER TO THE PRESENCE OF IMPORTANT OPERATING AND MAINTENANCE (SERVICING) INSTRUCTIONS IN THE LITERATURE ACCOMPANYING THE APPLIANCE.

## SUBJECT : TIPS ON PROPER INSTALLATION

1. NEVER INSTALL ANY PRODUCT IN A CLOSED-IN RECESS, CUBBYHOLE OR CLOSELY FITTING SHELF SPACE. OVER OR CLOSE TO HEAT DUCT, OR IN THE PATH OF HEATED AIR FLOW.
2. AVOID CONDITIONS OF HIGH HUMIDITY SUCH AS: OUTDOOR PATIO INSTALLATIONS WHERE DEW IS A FACTOR, NEAR STEAM RADIATORS WHERE STEAM LEAKAGE IS A FACTOR, ETC.
3. AVOID PLACEMENT WHERE DRAPERIES MAY OBSTRUCT REAR VENTING. THE CUSTOMER SHOULD ALSO AVOID THE USE OF DECORATIVE SCARVES OR OTHER COVERINGS WHICH MIGHT OBSTRUCT VENTILATION.
4. WALL AND SHELF MOUNTED INSTALLATIONS USING A COMMERCIAL MOUNTING KIT MUST FOLLOW THE FACTORY APPROVED MOUNTING INSTRUCTIONS A PRODUCT MOUNTED TO A SHELF OR PLATFORM MUST RETAIN ITS ORIGINAL FEET (OR THE EQUIVALENT THICKNESS IN SPACERS) TO PROVIDE ADEQUATE AIR FLOW ACROSS THE BOTTOM, BOLTS OR SCREWS USED FOR FASTENERS MUST NOT TOUCH ANY PARTS OR WIRING. PERFORM LEAKAGE TEST ON CUSTOMIZED INSTALLATIONS.
5. CAUTION CUSTOMERS AGAINST THE MOUNTING OF A PRODUCT ON SLOPING SHELF OR A TILTED POSITION, UNLESS THE PRODUCT IS PROPERLY SECURED.
6. A PRODUCT ON A ROLL-ABOUT CART SHOULD BE STABLE ON ITS MOUNTING TO THE CART. CAUTION THE CUSTOMER ON THE HAZARDS OF TRYING TO ROLL A CART WITH SMALL CASTERS ACROSS THRESHOLDS OR DEEP PILE CARPETS.
7. CAUTION CUSTOMERS AGAINST THE USE OF A CART OR STAND WHICH HAS NOT BEEN LISTED BY UNDERWRITERS LABORATORIES, INC. FOR USE WITH THEIR SPECIFIC MODEL OF TELEVISION RECEIVER OR GENERICALLY APPROVED FOR USE WITH T.V.'S OF THE SAME OR LARGER SCREEN SIZE.
8. CAUTION CUSTOMERS AGAINST THE USE OF EXTENSION CORDS, EXPLAIN THAT A FOREST OF EXTENSIONS SPROUTING FROM A SINGLE OUTLET CAN LEAD TO DISASTROUS CONSEQUENCES TO HOME AND FAMILY.

# SERVICING PRECAUTIONS

**CAUTION** : Before servicing the A/V Receiver covered by this service data and its supplements and addends, read and follow the **SAFETY PRECAUTIONS**. **NOTE** : if unforeseen circumstances create conflict between the following servicing precautions and any of the safety precautions in this publication, always follow the safety precautions.

*Remember Safety First:*

## General Servicing Precautions

1. Always unplug the A/V Receiver AC power cord from the AC power source before:
  - (1) Removing or reinstalling any component, circuit board, module, or any other assembly.
  - (2) Disconnecting or reconnecting any internal electrical plug or other electrical connection.
  - (3) Connecting a test substitute in parallel with an electrolytic capacitor.**Caution** : A wrong part substitution or incorrect polarity installation of electrolytic capacitors may result in an explosion hazard.
2. Do not spray chemicals on or near this A/V Receiver or any of its assemblies.
3. Unless specified otherwise in this service data, clean electrical contacts by applying an appropriate contact cleaning solution to the contacts with a pipe cleaner, cottontipped swab, or comparable soft applicator.  
Unless specified otherwise in this service data, lubrication of contacts is not required.
4. Do not defeat any plug/socket B+ voltage interlocks with which instruments covered by this service manual might be equipped.
5. Do not apply AC power to this A/V Receiver and/or any of its electrical assemblies unless all solid-state device heat sinks are correctly installed.
6. Always connect test instrument ground lead to the appropriate ground before connecting the test instrument positive lead. Always remove the test instrument ground lead last.

## Insulation Checking Procedure

Disconnect the attachment plug from the AC outlet and turn the power on. Connect an insulation resistance meter(500V) to the blades of the attachment plug. The insulation resistance between each blade of the attachment plug and accessible conductive parts (Note 1) should be more than 1M-ohm.

**Note 1** : Accessible Conductive Parts including Metal panels, Input terminals, Earphone jacks, etc.

## Electrostatically Sensitive (ES) Devices

Some semiconductor (solid state) devices can be damaged easily by static electricity. Such components commonly are called Electrostatically Sensitive (ES) Devices. Examples of typical Es devices are integrated circuits and some field effect transistors and semiconductor chip components.

The following techniques should be used to help reduce the incidence of component damage caused by static electricity.

1. Immediately before handling any semiconductor component or semiconductor-equipped assembly, drain off any electrostatic charge on your body by touching a known earth ground. Alternatively, obtain and wear a commercially available discharging wrist strap device, which should be removed for potential shock reasons prior to applying power to the unit under test.
2. After removing an electrical assembly equipped with ES devices, place the assembly on a conductive surface such as aluminum foil, to prevent electrostatic charge buildup or exposure of the assembly.
3. Use only a grounded-tip soldering iron to solder or unsolder ES devices.
4. Use only an antistatic solder removal device. Some solder removal devices not classified a "anti-static" can generate electrical charges sufficient to damage ES devices.
5. Do not use freonpropelled chemicals. These can generate electrical charge sufficient to damage ES devices.
6. Do not remove a replacement ES device from its protective package until immediately before you are ready to install it. (Most replacement ES devices are packaged with leads electrically shorted together by conductive foam, aluminum foil, or comparable conductive material).
7. Immediately before removing the protective material from the leads of a replacement ES device, touch the protective material to the chassis or circuit assembly into which the device will be installed.

**Caution** : Be sure no power is applied to the chassis or circuit, and observe all other safety precautions.

8. Minimize bodily motions when handing unpackaged replacement ES devices. (Normally harmless motion such as the brushing together of your clothes fabric or the lifting of your foot from a carpeted floor can generate static electricity sufficient to damage an ES device.)

# SERVICE SAFETY PRECAUTIONS

## 1. Replacing the fuses

**CAUTION:** FOR CONTINUED PROTECTION AGAINST THE RISK OF FIRE REPLACE ONLY WITH SAME TYPE OF FUSE.

Reference No			Part Number	Description
M270	*AH	△	5120-0200-0	5A TIME-LAG 5x20 UL/CSA
M271	*C	△	5120-0024-0	3.15A TIME-LAG 5x20 VDE-SEMKO
M272	*AH	△	5120-0052-0	1.6A TIME-LAG 5x20 UL/CSA

NOTE:

<\*AH > : USA, CANADIAN MODEL ONLY.

<\*C > : EUROPEAN MODEL ONLY.

## 2. Safety check out

(Only U.S.A. model)

Before returning the product to the customer, make leakage current or resistance measurements to determine that exposed parts are acceptably insulated from the supply circuit.

Parts marked with the symbol △ are critical with regard to the risk of fire and electric shock.  
Replace only with parts recommended by the manufacturer.

## CONTENTS

DESCRIPTION	PAGE
SPECIFICATIONS .....	3-4
REAR PANEL / FRONT PANEL .....	5
DISASSEMBLY INSTRUCTIONS .....	6
WIRING DIAGRAM .....	7-8
BLOCK DIAGRAM .....	9
ADJUSTMENT POINTS DIAGRAM .....	10-11
INSTRUMENT SETUP .....	12
ALIGNMENT PROCEDURES .....	12-13
IMPORTANT NOTES .....	13
PCB LAYOUT .....	14-24
SCHEMATIC DIAGRAM .....	25-42
IC BLOCK DIAGRAM .....	43-51
ELECTRICAL PARTS LIST .....	52-71
EXPLODED VIEW .....	72
EXPLODED VIEW PARTS LIST .....	73-74
PACKING DIAGRAM .....	75

# SPECIFICATIONS

## **POWER AMPLIFIER AND PREAMPLIFIER SECTION (all channels stated 8 ohms)**

Rated distortion	(THD 20Hz-20 kHz FL/C/FR)	≤ 0.08%
	(THD 20Hz-20 kHz SL/SR)	≤ 0.3%
Input Sensitivity	(ref. 8 ohms, 1 kHz)	180+/-30 mV
S/N Ratio	(A-wtd, 1KHz, 1W, 8 ohm)	≥ -78 dB
	(A-wtd, 1KHz, 80W, 8 ohm)	≥ 92 dB
	FL/FR/C	≥ -90 dB
	SL/SR	≥ -90 dB
Frequency Response	(20 Hz - 20 kHz)	0 ± 0.8 dB
Channel Balance	(1 dB to -40 dB, 1 kHz)	≤ 2 dB
	(-41 dB to -50 dB, 1 kHz)	≤ 3 dB
Audio muting at 1kHz		≥ 53 dB
Headphone O/P in 0.1%, 600 ohm load, CD in 500mV, 1 kHz		≥ 10V
Subwoofer out, 500mV in	(THD at 2V O/P, 100 Hz)	≥ 0.5%
	(S/N at 2V O/P, 100 Hz)	≥ 80 dB
Crosstalk	(2V input, 10W, 1 kHz)	> -68 dB
Continuous average power output (L/R/C RL/RR 8 ohms)		50 W

### **Controls**

Bass	(at 500mV in, 1W out, 100 Hz)	± 9 dB
Treble	(at 500mV in, 1W out, 10 kHz)	± 9 dB

## **SURROUND SECTION**

### **Channel separation**

I/p mode : L, R	: 1V in, 1 kHz, Ch R, L	≥ 45 dB
	: o/p at unexpected, 1 kHz, Ch C	≥ 35 dB
I/p mode : L= -R	: 1V in, 1 kHz, Ch R, L	≥ 28 dB
	: o/p at unexpected, 1 kHz, Ch C	≥ 30 dB
I/p mode : L= R	: 1V in, 1 kHz, Ch R, L	≥ 45 dB
	: o/p at unexpected, 1 kHz, Ch SL, SR	≥ 30 dB

### **Frequency Response**

I/p mode : L, R	: 1V in, 1W, Ch R, L	40Hz	0 ± 1.5 dB
		20kHz	0 ± 1.5 dB
I/p mode : L= R	: 1V in, 1W, Ch C	300Hz	0 ± 0.8 dB
		20kHz	0 ± 0.8 dB
I/p mode : L= -R	: 1V in, 1W, Ch SL, SR	30Hz	0 ± 1.0 dB
		6.5kHz	-3 ± 1.0 dB

S/N Ratio ( 200mV in, 1, A-WTD w/ 1k termination)

I/p mode : L, R	: 1 kHz, Ch L, R	≥ 65 dB
I/p mode : L=R	: 1 kHz, Ch C	≥ 65 dB
I/p mode : L=-R	: 1 kHz, Ch SL, SR	≥ 65 dB
THD (2.2V in, 1W, w/ 80 kHz LPF, 1 kHz)		≤ 0.2%

## **DTS SECTION**

### **Frequency Response**

FL, FR, C, SL, SR:	200Hz	0 ± 0.8 dB
	20kHz	0 ± 0.8 dB
Distortion 1W all channels		0.08%

## **AM TUNER SECTION**

Input level is expressed as the reading in open-circuit  
of 75-ohm source impedance signal generator

Usable sensitivity (999/1000kHz)		≤ 30 dBμ
S/N Ratio (5mV in)		≥ 38 dB
THD (5mV in)		≤ 3%
IF Rejection (450 kHz)		≥ 45 dB
Image Rejection (F+2xIF)		≥ 28 dB
Selectivity		≥ 17 dB
Output		130+/- 20mV
Loop sensitivity (20dB S/N)		
	999/1000 kHz	≤ 66 dB
	603/600 kHz	≥ 66 dB
	1404/1400 kHz	≤ 66 dB
Frequency response (100 - 2.3 kHz, 5mV)		± 6 dB

## **FM TUNER SECTION**

Input level is expressed as the reading in open-circuit  
of 75-ohm source impedance signal generator

Usable Sensitivity ( 98 MHz)		≤ 15 dBμ
Signal / Noise Ratio	Mono	≥ 72 dB
(60 dBμ, IHF wtd)	Stereo	≥ 66 dB
Frequency Response (20 Hz - 15 kHz, 60 dBμ)		0 ± 1.5 dB
Channel Separation (60 dBμ)	100 Hz	≥ 30 dB
	1 kHz	≥ 40 dB
	10 kHz	≥ 30 dB
Alternate Channel Selectivity		
(40 dBμ, ±400 kHz)		≥ 60 dB
Capture Ratio (40 dBμ)		≥ 3 dB
AM Suppression		
(60 dBμ, 100% Mod.FM, 30% Mod.AM)		≥ 48 dB
Image Rejection (119.4 MHz)		≥ 68 dB
I.F. Rejection ( 10.7 MHz)		≥ 78 dB
Pilot Suppression (60 dBμ)		≥ 60 dB
THD (60 dBμ, L=R 75 kHz for AH, 40 kHz Dev for C)		
	Mono	≤ 0.25%
	Stereo	≤ 0.35%
Auto-Search Sensitivity	On	≥ 24 dBμ
	Off	≤ 15 dBμ
RDS decode Sensitivity		≤ 26 dBμ

## **POWER RATING**

EUROPEAN Model	*C	AC 230V~ 50Hz 1.2A
USA, CANADIAN Model	*AH	AC 120V~ 60Hz 2.5A

## **PHYSICAL SPECIFICATIONS**

Dimensions (Width x Height x Depth)	435 x 131 x 348mm
Net weight	14kg (31 lbs)
Shipping weight	16.7kg (37 lbs)

# REAR PANEL / FRONT PANEL

## REAR PANEL

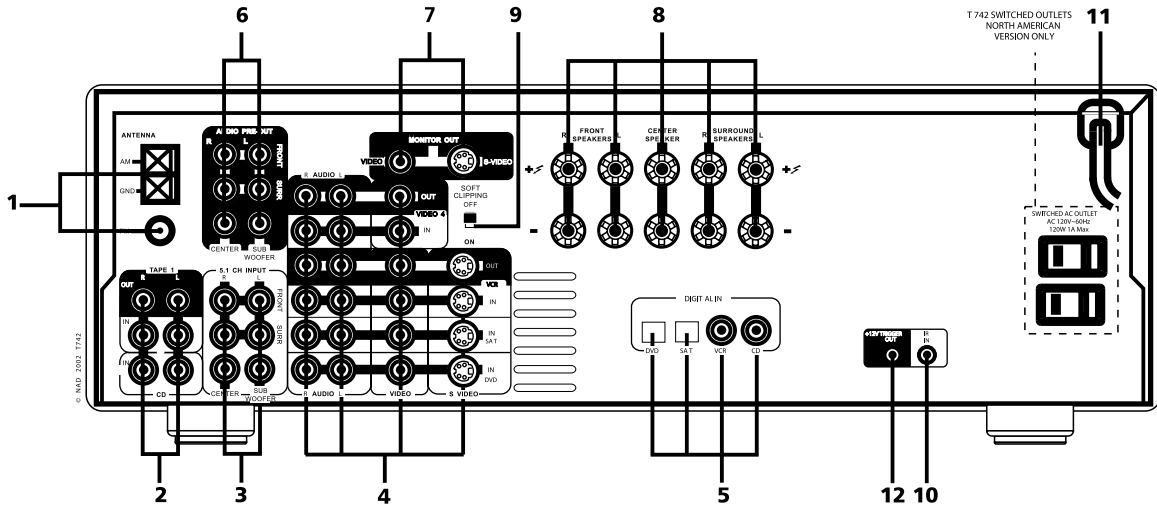

- |  |  |
|--|--|
| 1. FM & AM ANTENNA                         | 7. MONITOR OUT                                 |
| 2. TAPE 1 & CD INPUTS                      | 8. SPEAKERS: FRONT, CENTER & SURROUND SPEAKERS |
| 3. 5.1 CHANNEL INPUTS                      | 9. SOFT CLIPPING                               |
| 4. DVD - SAT VCR - VIDEO 4 (AUDIO & VIDEO) | 10. IR INPUT                                   |
| 5. DIGITAL AUDIO INPUTS                    | 11. AC POWER CORD                              |
| 6. AUDIO PRE OUTS / SUBWOOFER OUT          | 12. 12 VOLT TRIGGER OUT                        |

## FRONT PANEL

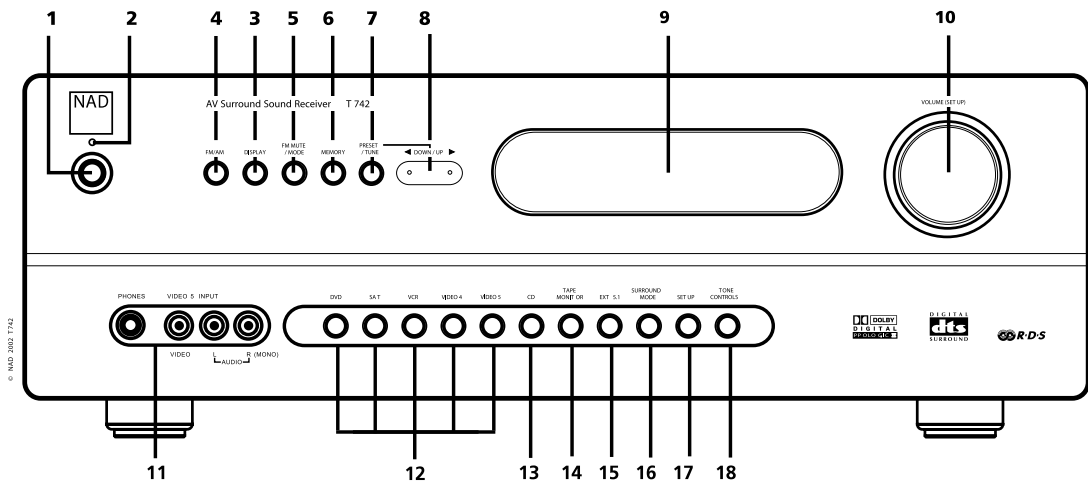

- |                       |                                      |
|-----------------------|--------------------------------------|
| 1. POWER              | 10. VOLUME & SETUP                   |
| 2. STAND-BY INDICATOR | 11. HEADPHONE SOCKET & VIDEO 5 INPUT |
| 3. DISPLAY            | 12. AUDIO & VIDEO INPUT SELECTORS    |
| 4. FM/AM              | 13. CD                               |
| 5. FM MUTE / MODE     | 14. TAPE MONITOR                     |
| 6. MEMORY             | 15. EXT. 5.1                         |
| 7. PRESET / TUNE      | 16. SURROUND MODE                    |
| 8. DOWN / UP ◀ AND ▶  | 17. SET UP                           |
| 9. VFL DISPLAY        | 18. TONE CONTROLS                    |

# DISASSEMBLY INSTRUCTIONS

1. Remove machine screws M 4.0 x 6.0 ( ① to ⑥ ) from the side panels.  
Remove tapping screw 3.0 x 8.5 ( ⑦ ) from the back panel.  
Refer to **Figure No.1**.

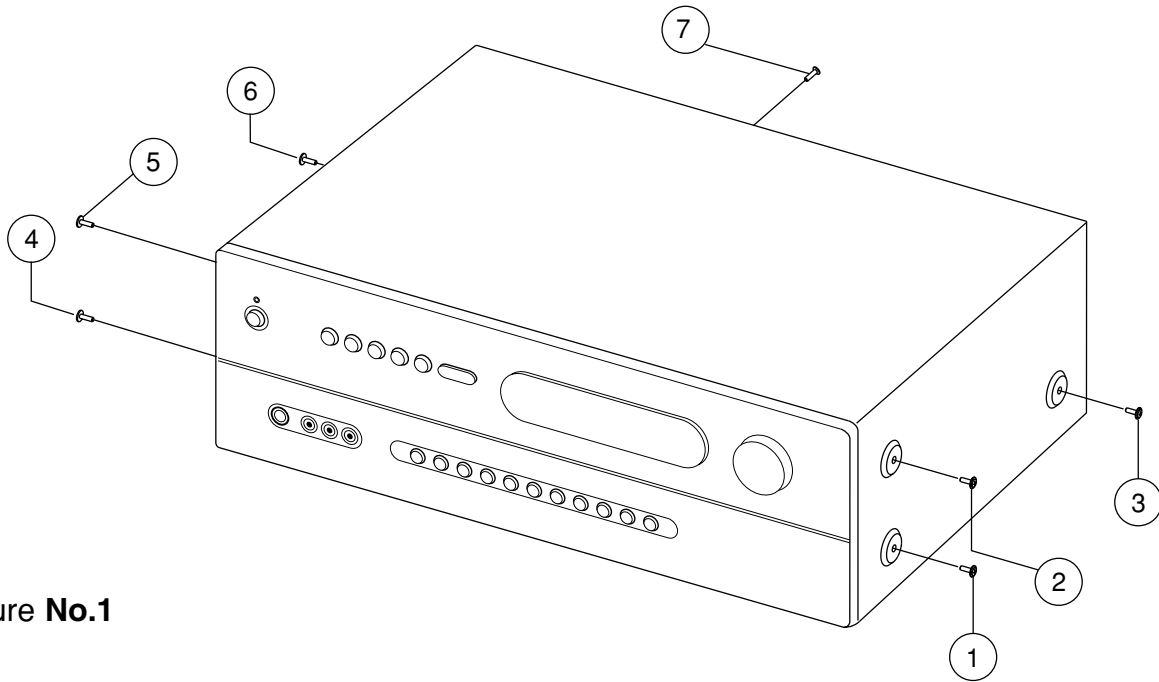

Figure No.1

2. Pull both sides of the TOP COVER slightly outwards ( ⑧ ) and tilt approx. 35° and then remove in the direction as indicated by the arrow ( ⑨ ). Refer to **Figure No.2**.

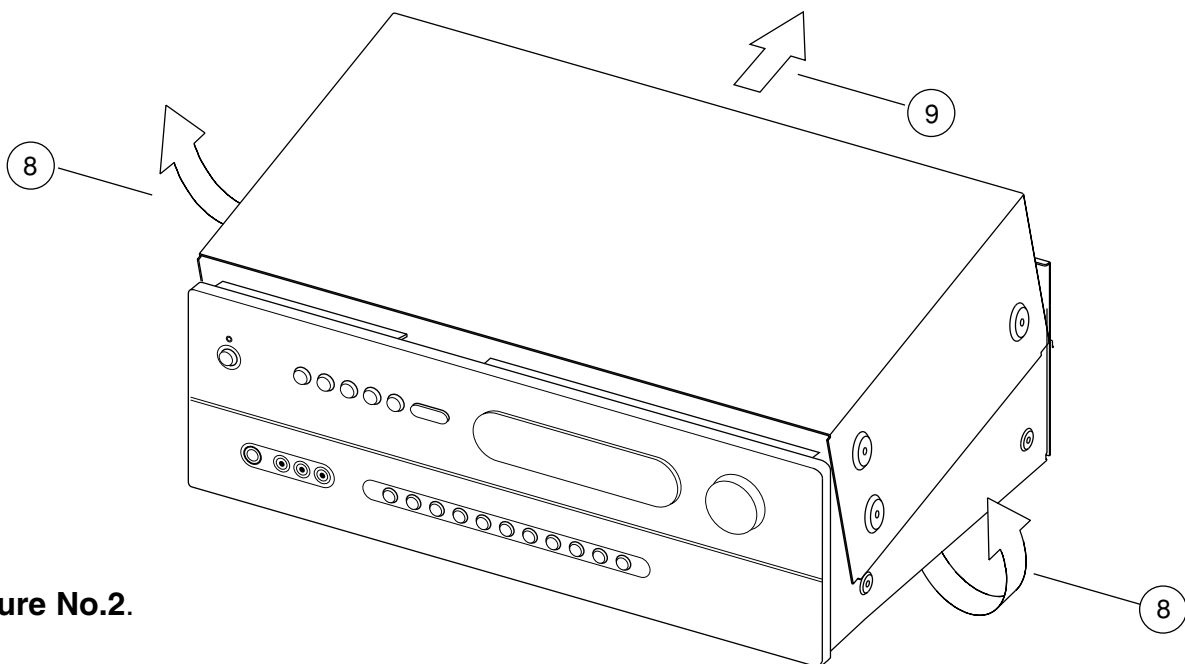
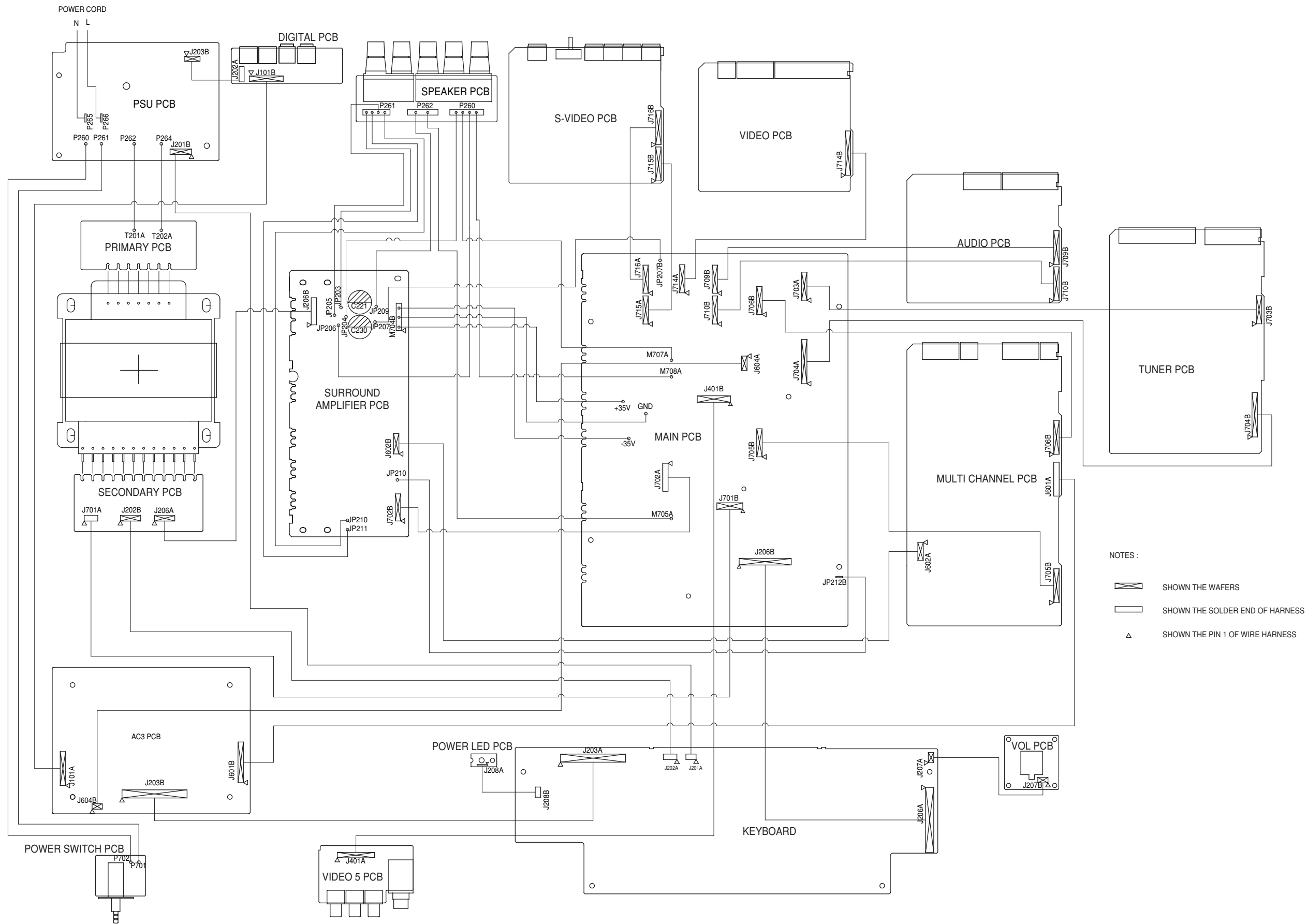





Figure No.2.



# WIRING DIAGRAM



- NOTES :
-  SHOWN THE WAFERS
  -  SHOWN THE SOLDER END OF HARNESS
  -  SHOWN THE PIN 1 OF WIRE HARNESS



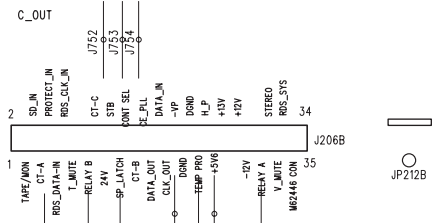
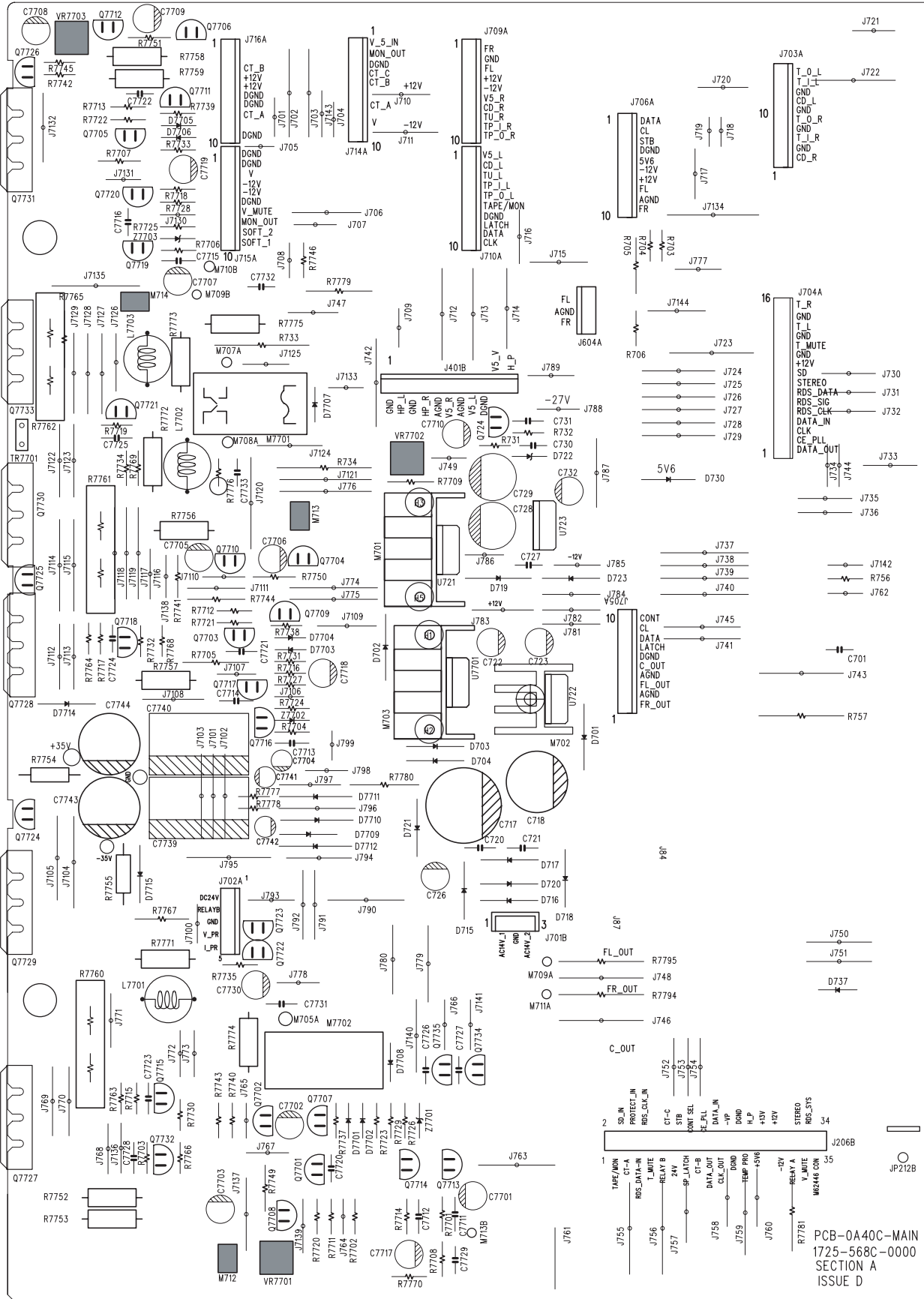

PCB-0A40C-MAIN  
1725-568C-0000  
SECTION A  
ISSUE D

# INSTRUMENT SETUP

## 1. FM MEASUREMENT

Fig. 1

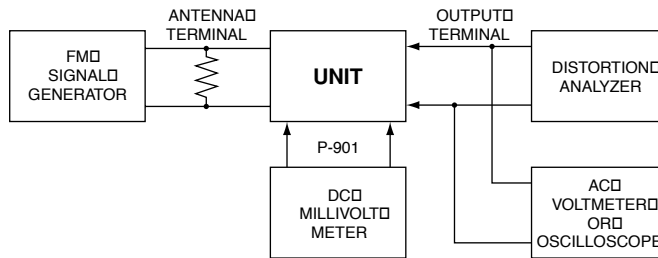
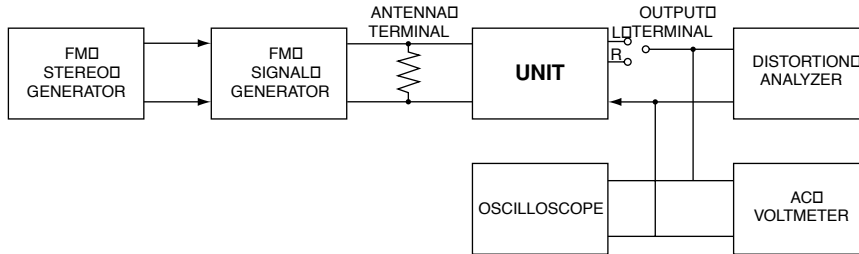
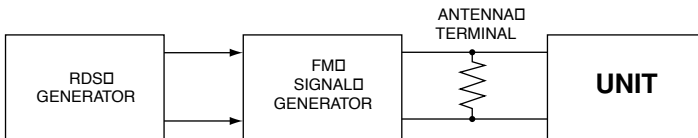

Fig. 2



## 2. RDS MEASUREMENT

Fig. 3



## 3. AM MEASUREMENT

Fig. 4

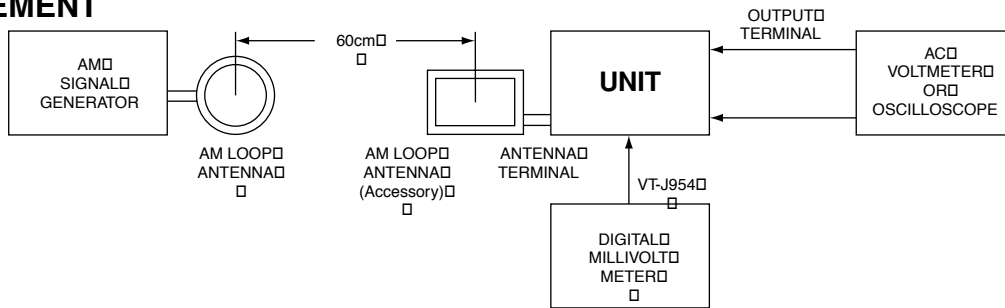

# ALIGNMENT PROCEDURES

## AMPLIFIER SECTION

Idle Current

Step	Item	Connection	Adjustment	Adjust for
1	Front Left Channel	Voltmeter to M714 on Main Board	VR7703	1mV±0.2mV
2	Front Right Channel	Voltmeter to M713 on Main Board	VR7702	1mV±0.2mV
3	Center Channel	Voltmeter to M712 on Main Board	VR7701	1mV±0.2mV
4	Rear Left Channel	Voltmeter to TP202 on Surround Amplifier Board (PCB N0A00C-AMP2)	VR202	1mV±0.2mV
5	Rear Right Channel	Voltmeter to TP201 on Surround Amplifier Board (PCB N0A00C-AMP2)	VR201	1mV±0.2mV

## FM/RDS SECTION

- FM mono: 1kHz, 75kHz devi., 60dB/μV
- FM stereo: 1kHz, 67.5kHz devi., 60dB/μV
- Pilot signal 19kHz 7.5kHz devi.

### OUTPUTS

- Connect the non-inductive type resistor of 8 ohms to the all speaker terminals unless otherwise noted.

Item	Step	Connection of instrument	FM SG output	Stereo modulator output	Tuning frequency	Output indicator	Adjustment point	Adjust for	Remarks
FM IF/RF	1	Fig.1	99.0MHz 1kHz 75kHz devi. 65dBf (60dB)	-	99.0MHz	DC voltmeter	L941	0±100mV	FM MUTE/MODE switch: ON/AUTO Repeat the steps 1 to 3 until no further adjustment is necessary.
	AC voltmeter					IFT on the front end	Maximum		
	Distortion analyzer					L942	Minimum		
Stereo Distortion		Fig.2	99.0MHz Ext. mod. 65dBf (60dB)	Channel L or R 1kHz	99.0MHz	Distortion analyzer	IFT on the front end	Minimum	FM MUTE/MODE switch: ON/AUTO Don't turn more than +/-180°
Stereo Separation		Fig.2	99.0MHz Ext. mod. 65dBf (60dB)	Channel L or R 1kHz	99.0MHz	Oscilloscope	R956	Maximum separation	Repeat stereo distortion and stereo separation alignment until THD at minimum and separation at maximum.
Muting Level		Fig.1	99.0MHz 18dB	-	99.0MHz	Oscilloscope	R941	Signal output	
RDS		Fig.3	99.0MHz Ext. mod.65dBf(60dB) RDS 2% MOD	-	99.0MHz	-	-	-	Decode the RDS-Program Station.

## AM SECTION

AM Modulation: 400Hz, 30%

For AH Version

Step	AM SG output	Tuning frequency	Output indicator	Adjustment point	Adjust for
1	-	530kHz	Digital DC voltmeter	OSC coil on RF block L971	1.35±0.2V
2	600kHz 400Hz 30% mod. 60dB/m	600kHz	AC voltmeter	RF coil on RF block L971	Maximum
3	600kHz 400Hz 30% mod. 60dB/m	990kHz	AC voltmeter	L972	Maximum

For C Version

Step	AM SG output	Tuning frequency	Output indicator	Adjustment point	Adjust for
1	-	522kHz or 531kHz	Digital DC voltmeter	OSC coil on RF block L971	1.3±0.2V (522kHz) 1.35±0.2V (531kHz)
2	600kHz 400Hz 30% mod. 60dB/m	603kHz	AC voltmeter	RF coil on RF block L971	Maximum
3	600kHz 400Hz 30% mod. 60dB/m	999kHz	AC voltmeter	L972	Maximum

## IMPORTANT NOTES

- 1. Show the software version**  
Press "FM/AM" and "EXT 5.1".
- 2. Light up all the icon on the VFL.**  
Press "FM/AM" and "TONE CONTROL".
- 3. Toggle between 9K and 10K**  
Press "FM/AM" and "CD".
- 4. Clear all tuner presets**  
Press "TAPE(MON)" and "VIDEO 1".

# PCB LAYOUT

## S-VIDEO BOARD

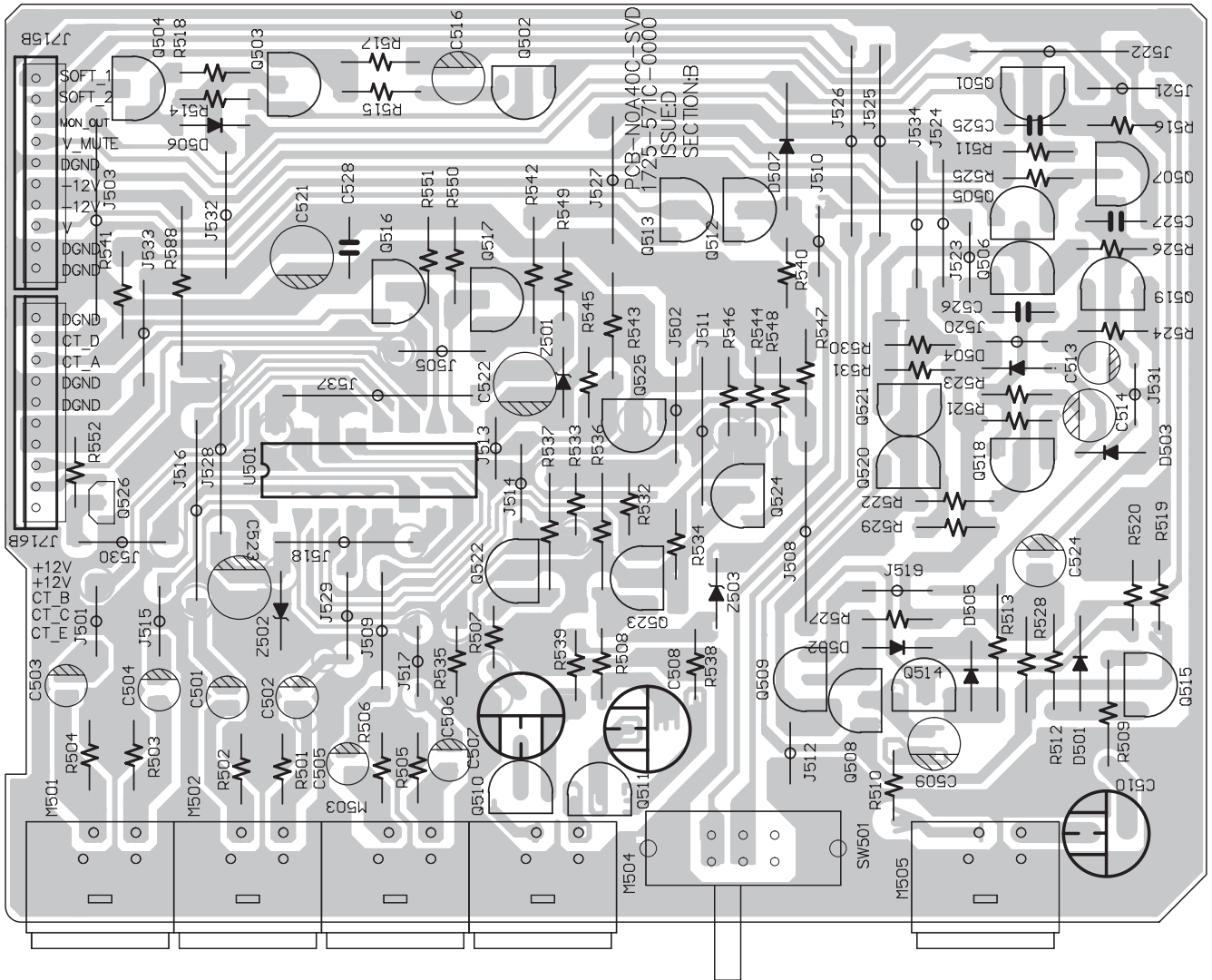

## VIDEO-5 BOARD

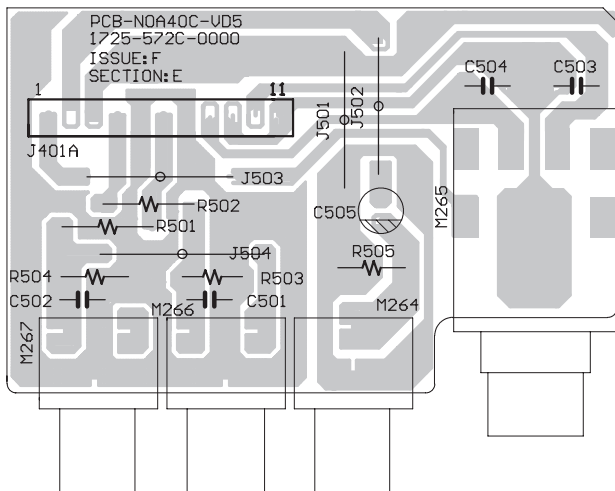

## VOLUME BOARD

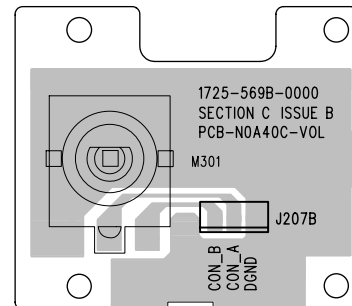

# VIDEO BOARD

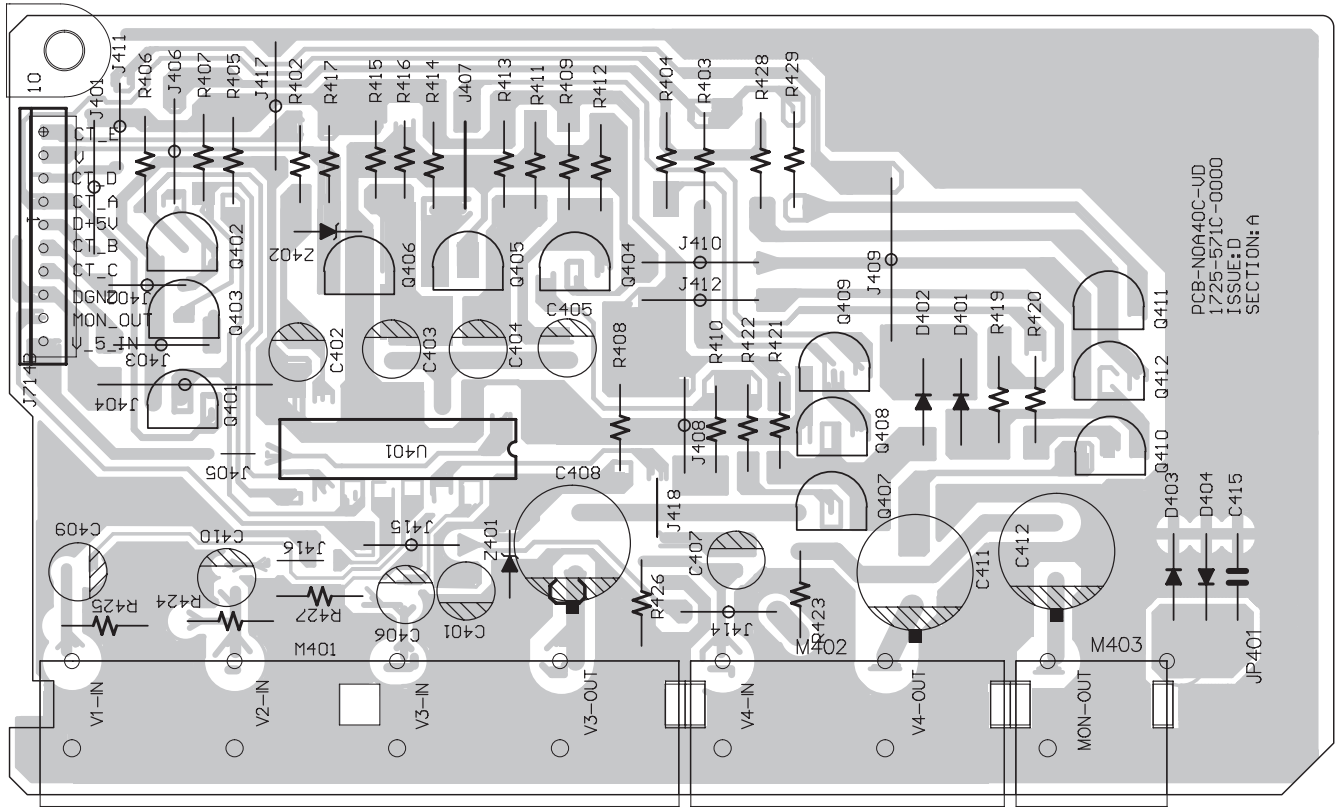

# TUNER BOARD

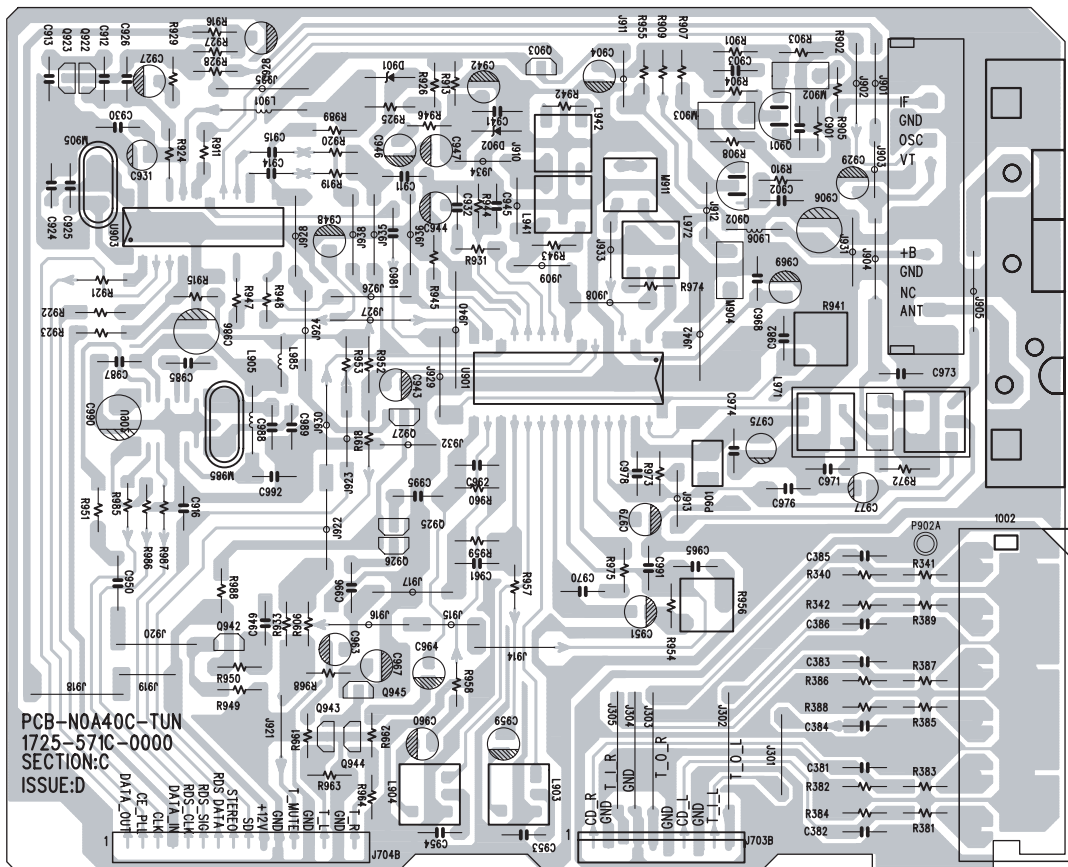

# SURROUND AMPLIFIER BOARD

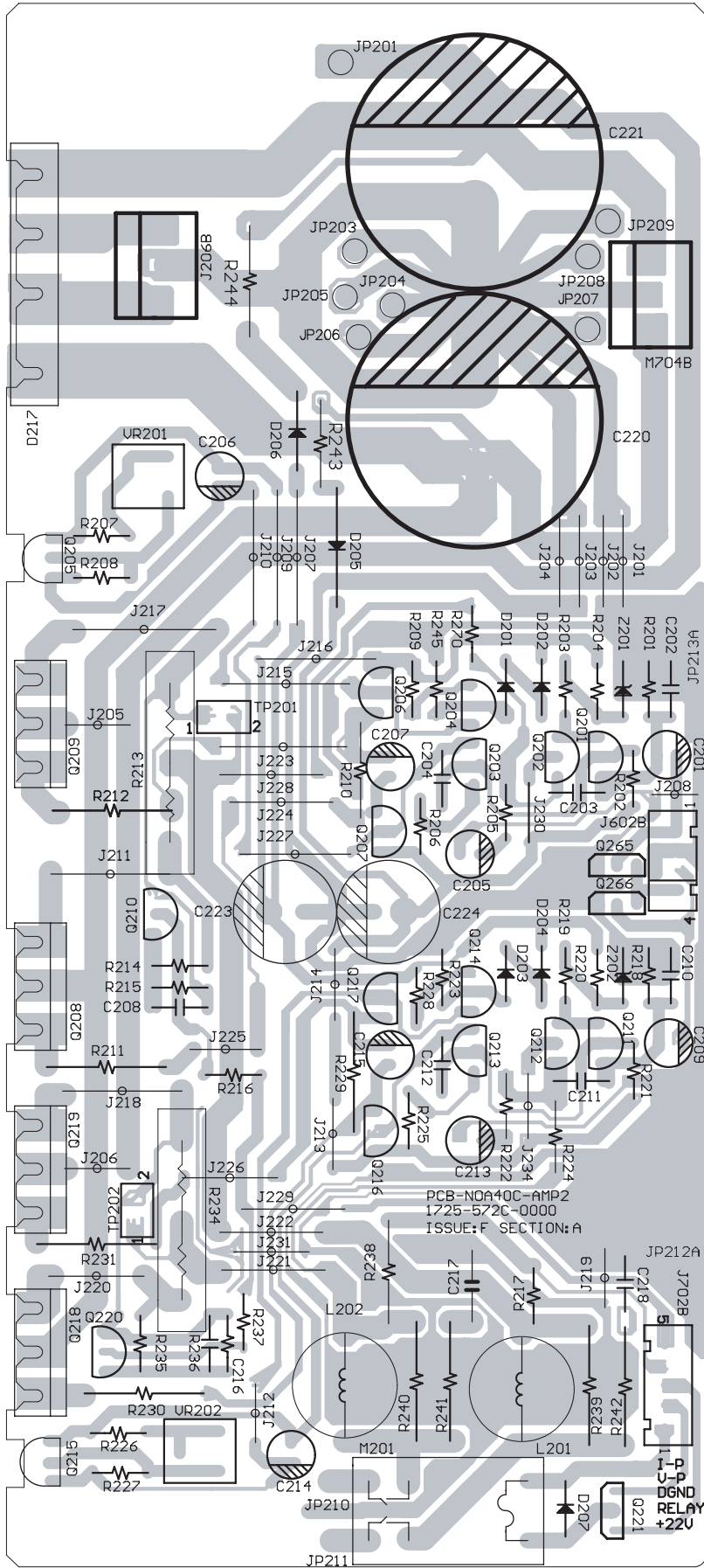

# PRIMARY BOARD

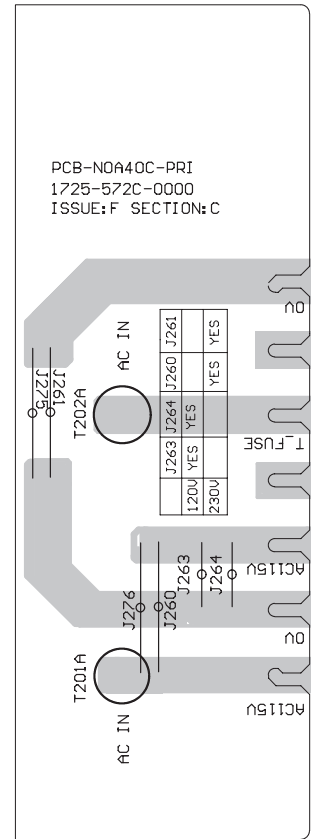

# SECONDARY BOARD

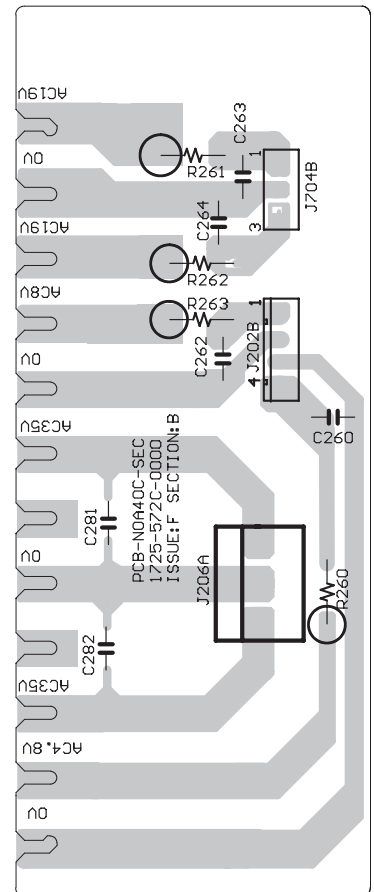



# AUDIO BOARD

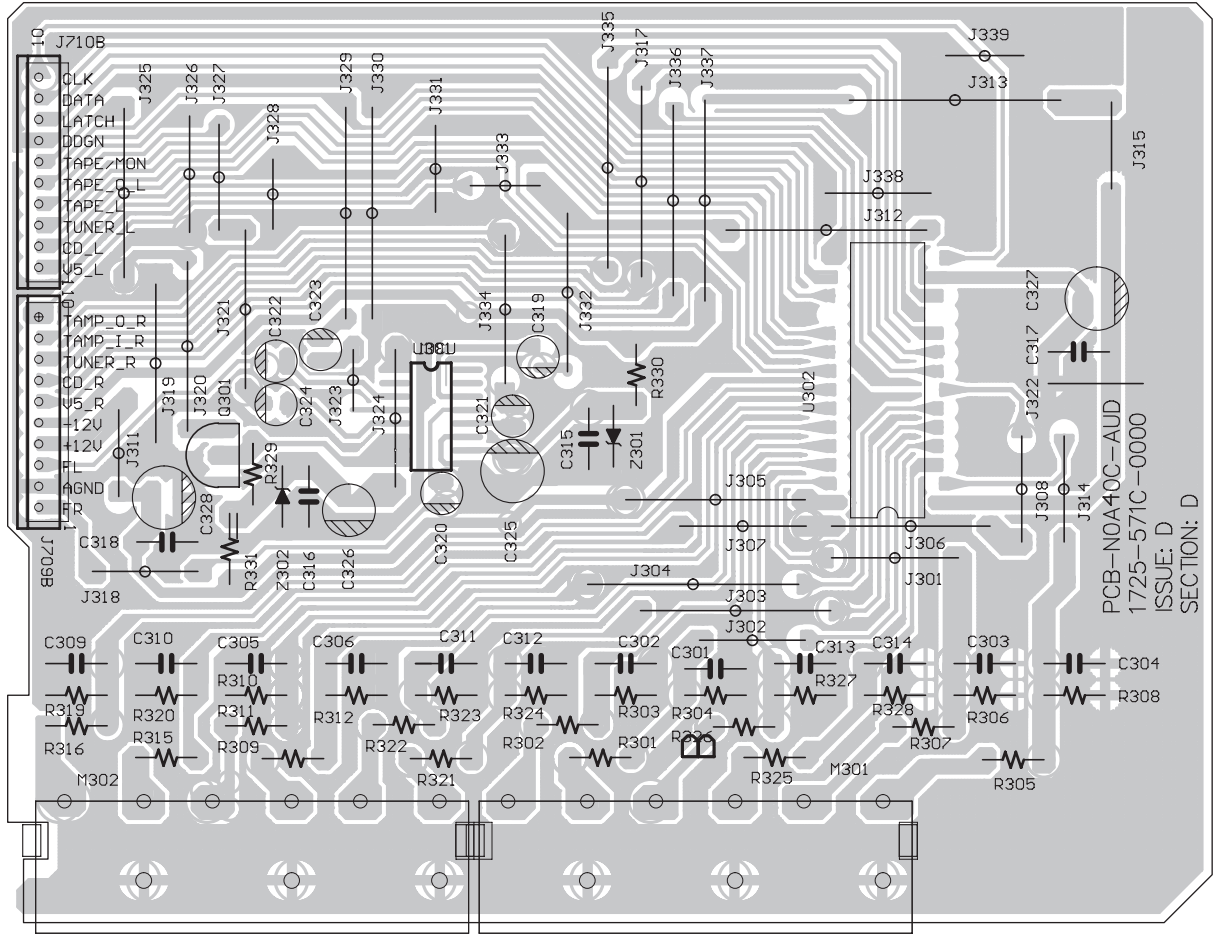

# PSU BOARD

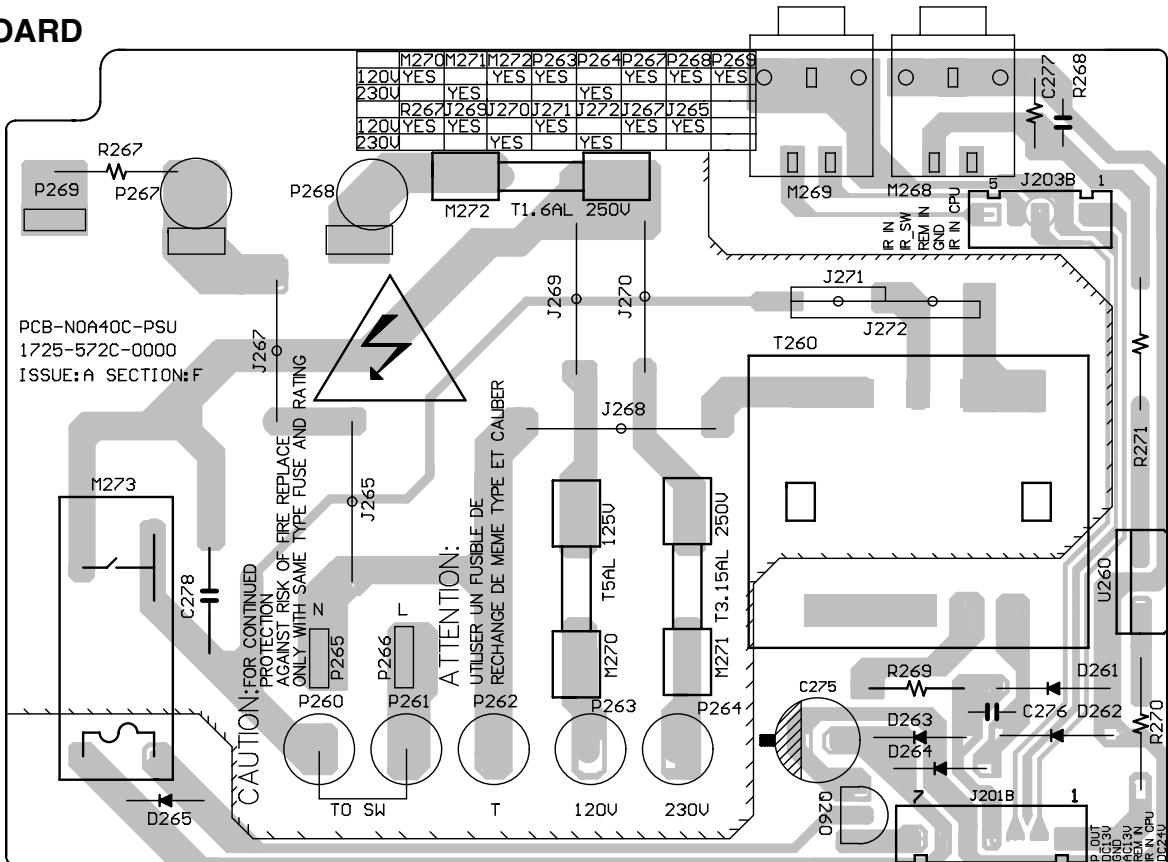





# MAIN BOARD

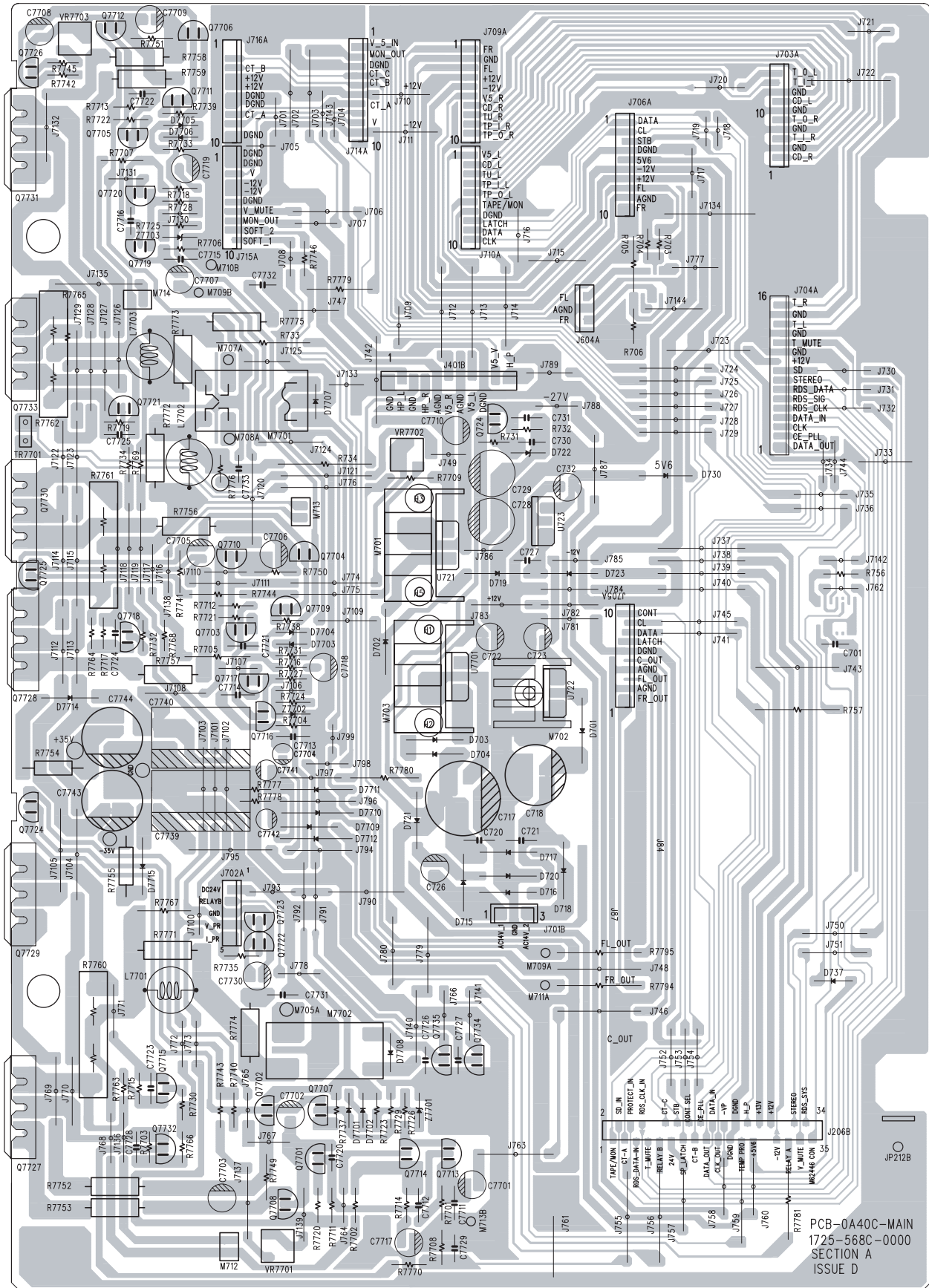

PCB-0A40C-MAIN  
1725-568C-0000  
SECTION A  
ISSUE D



# KEY BOARD

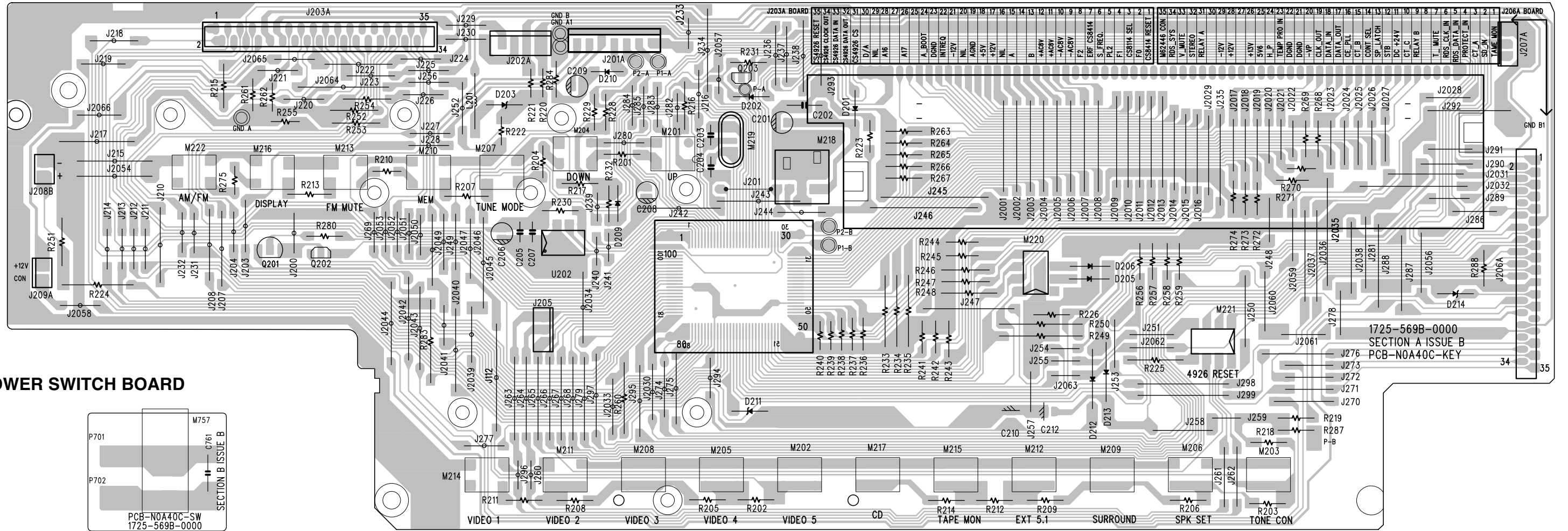

# POWER SWITCH BOARD

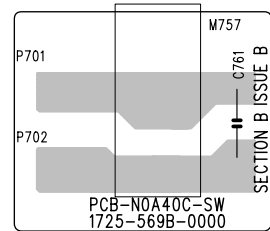

# DIGITAL BOARD

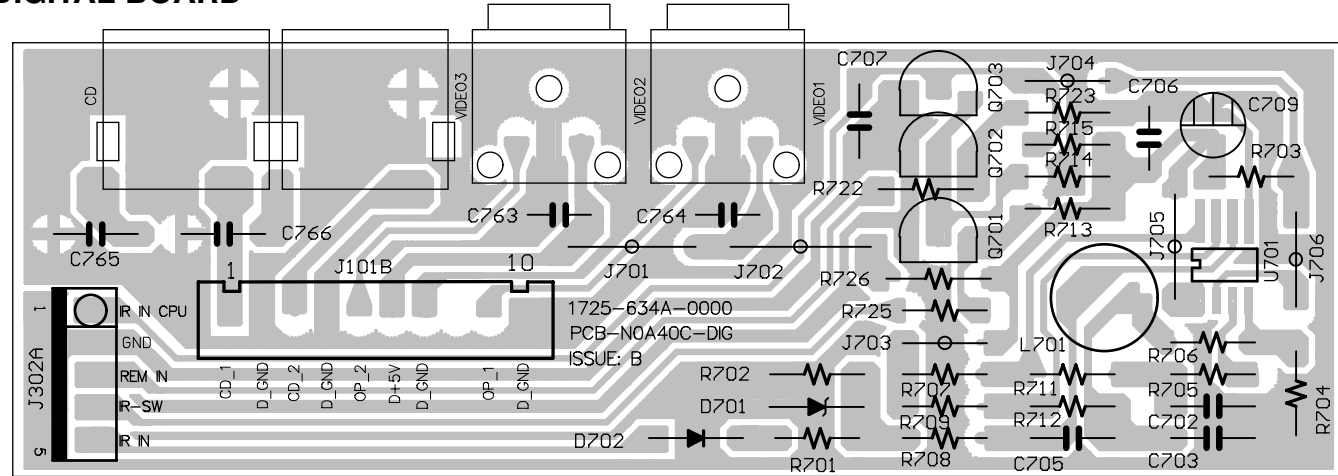

# SPEAKER BOARD

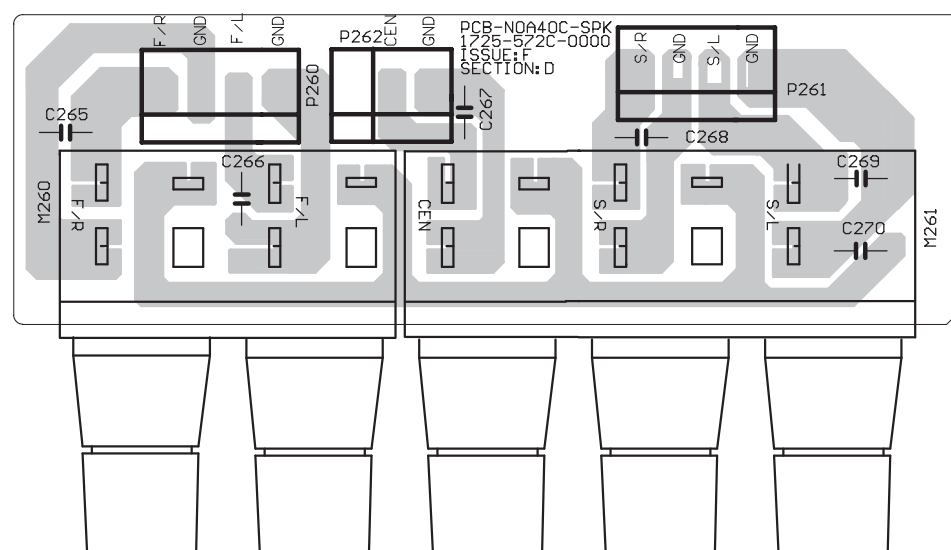

# LED BOARD

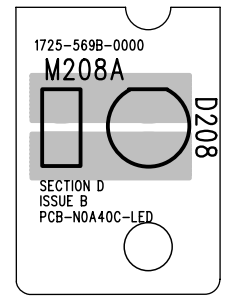

# SCHEMATIC DIAGRAM

## AC3 / DTS

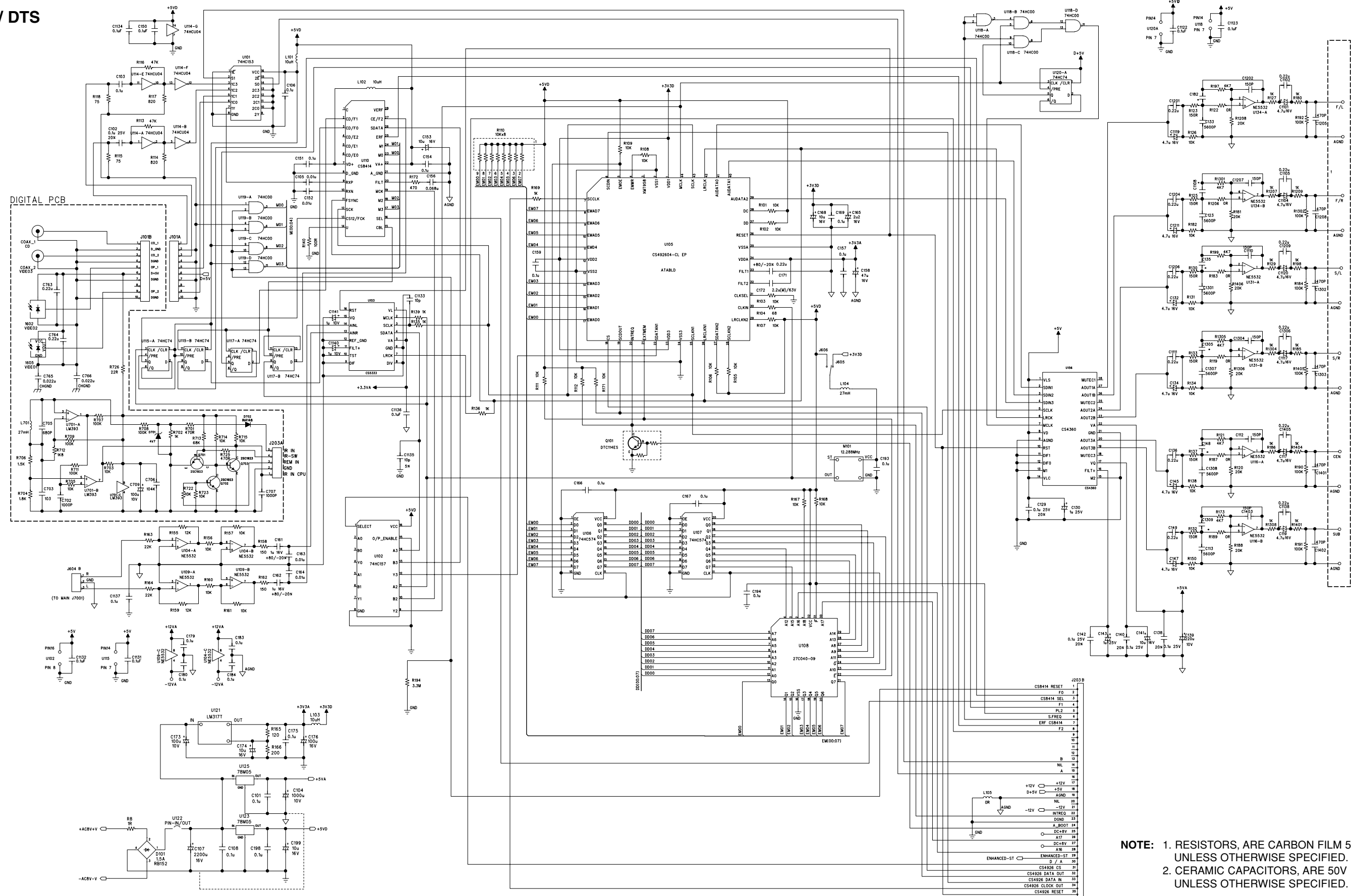

**NOTE:** 1. RESISTORS, ARE CARBON FILM 5% 1/10W UNLESS OTHERWISE SPECIFIED.  
2. CERAMIC CAPACITORS, ARE 50V 10%. UNLESS OTHERWISE SPECIFIED.

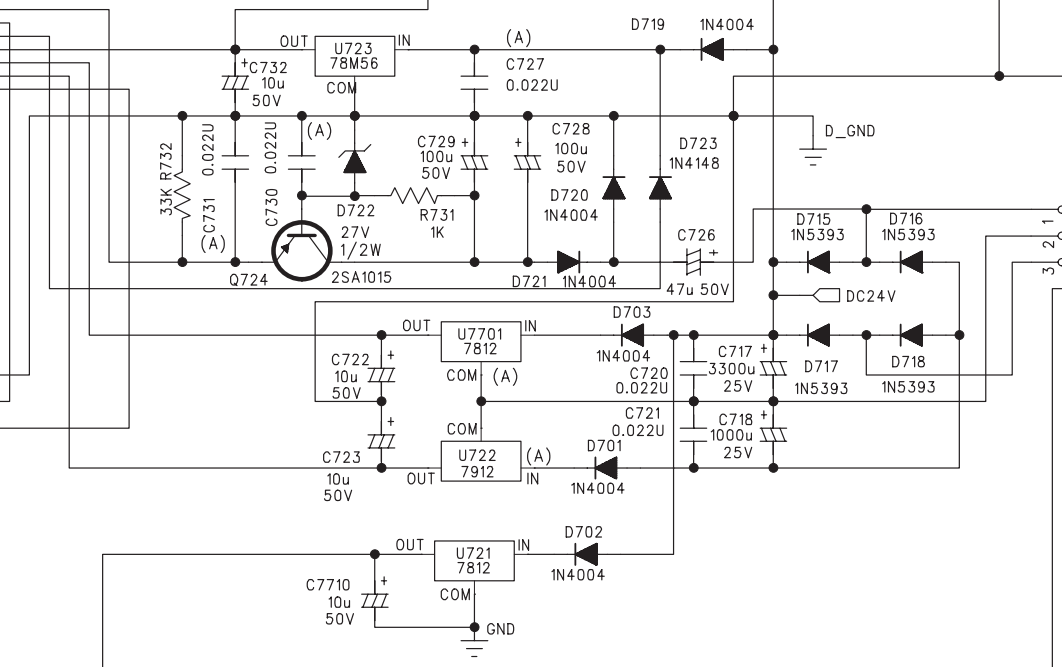
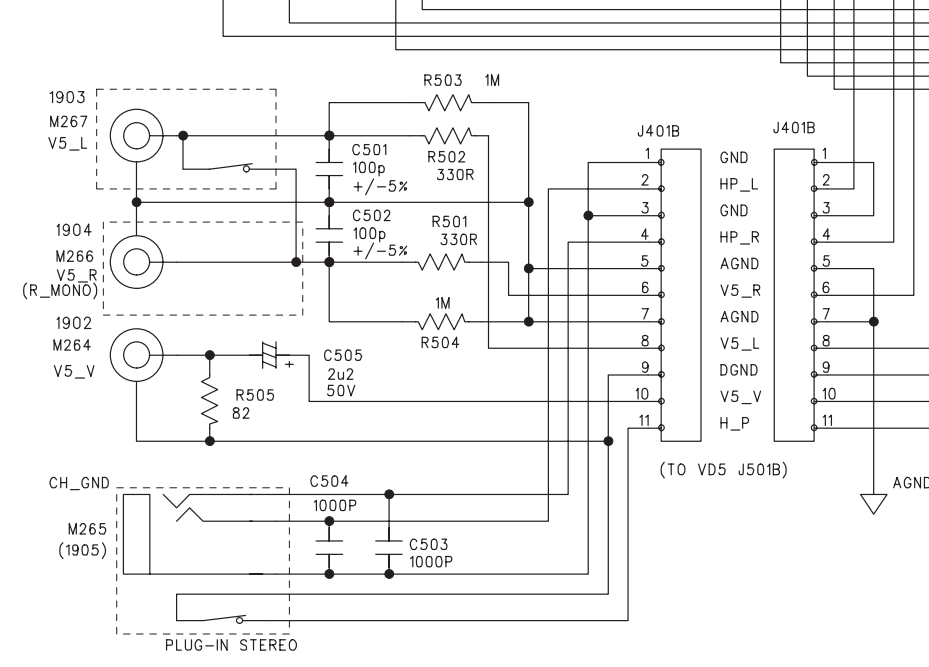
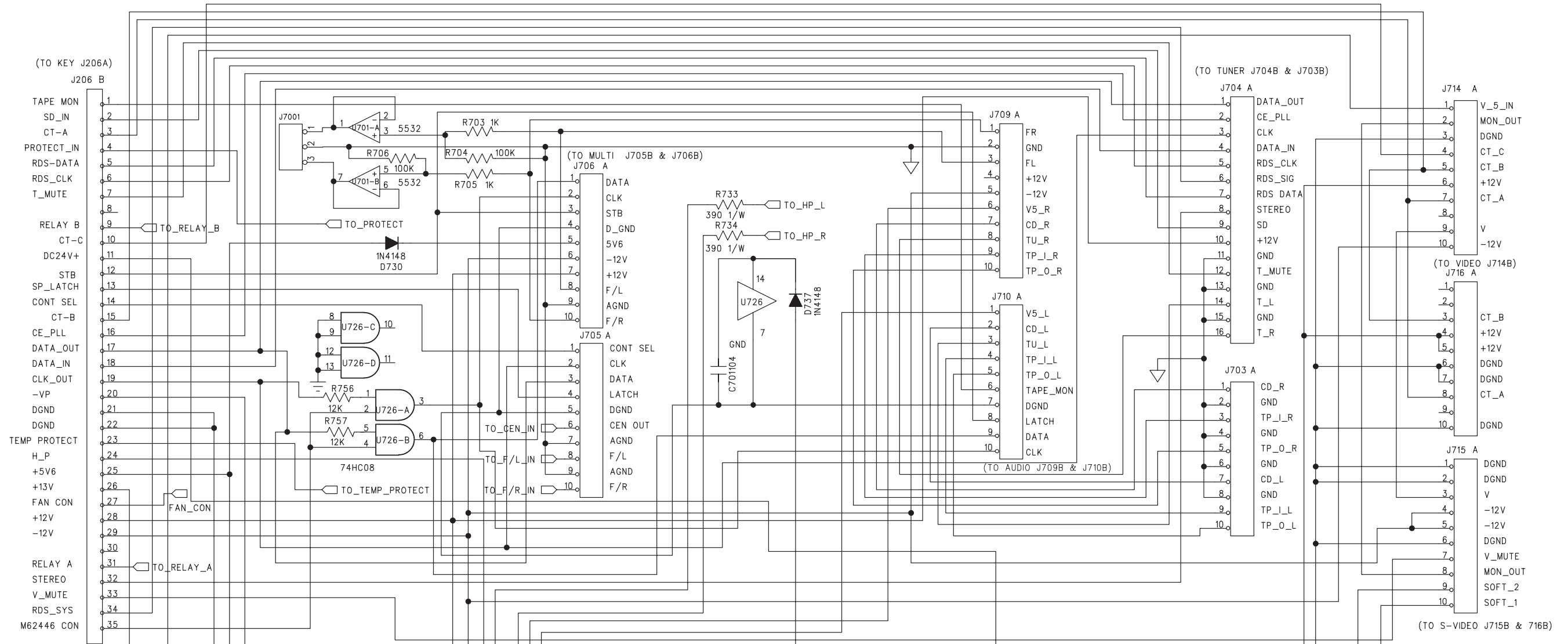

**NOTE:** 1. RESISTORS, ARE CARBON FILM 5% 1/8W UNLESS OTHERWISE SPECIFIED.  
MF-METAL FILM  
2. CERAMIC CAPACITORS, ARE 50V 10%. UNLESS OTHERWISE SPECIFIED.



# MULTI-CHANNEL

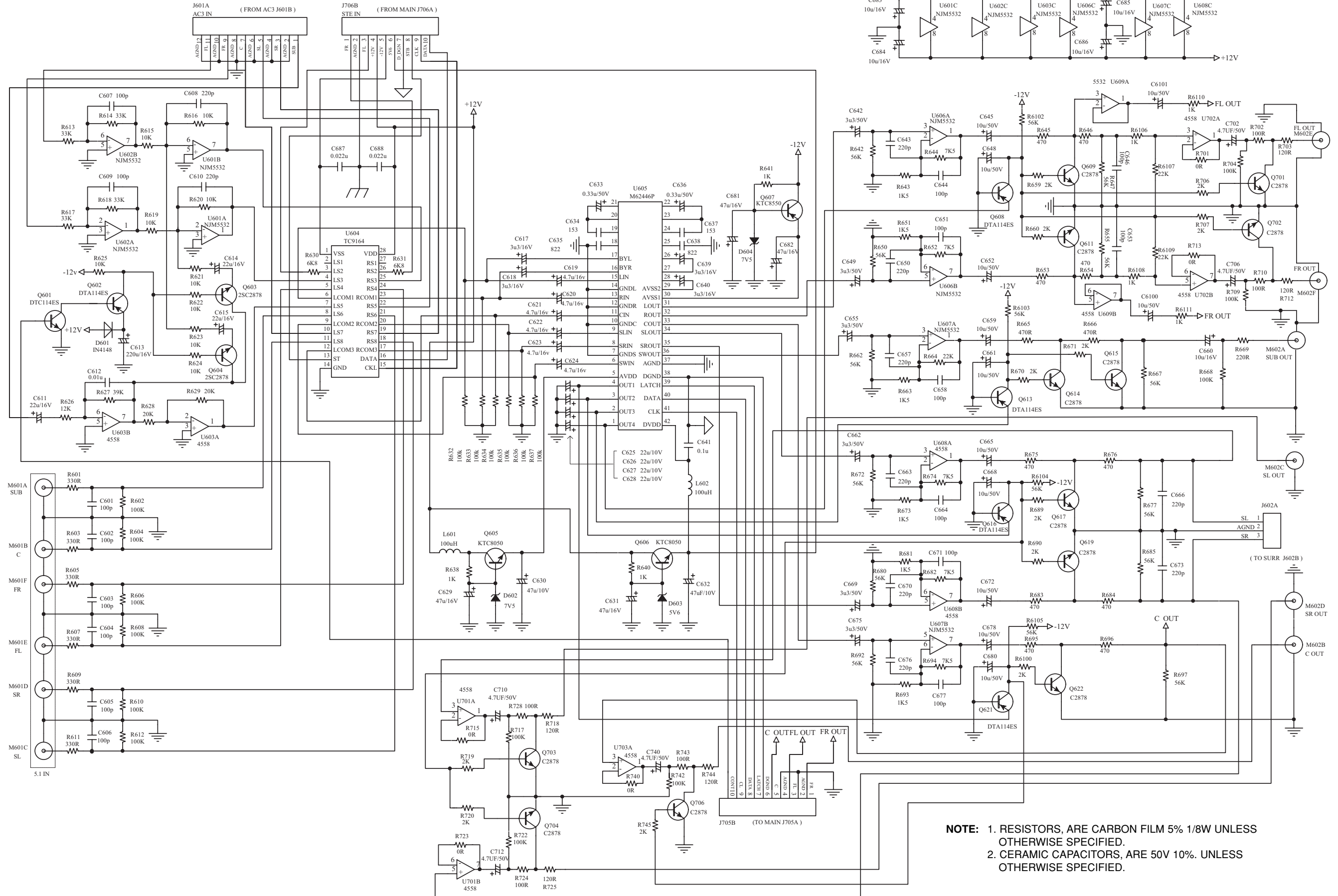

# KEYBOARD

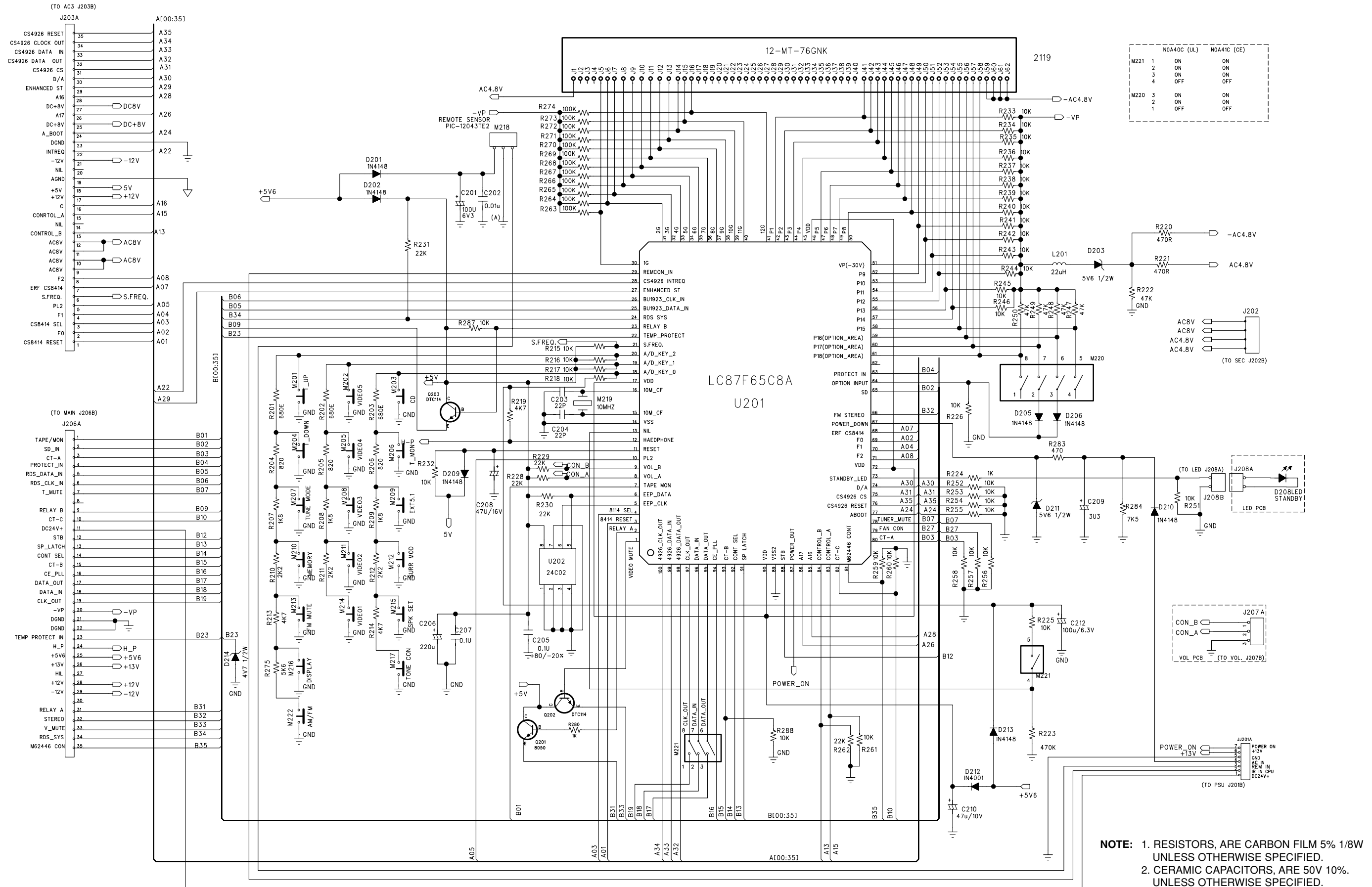

**NOTE:** 1. RESISTORS, ARE CARBON FILM 5% 1/8W UNLESS OTHERWISE SPECIFIED.  
 2. CERAMIC CAPACITORS, ARE 50V 10%. UNLESS OTHERWISE SPECIFIED.

# TUNER

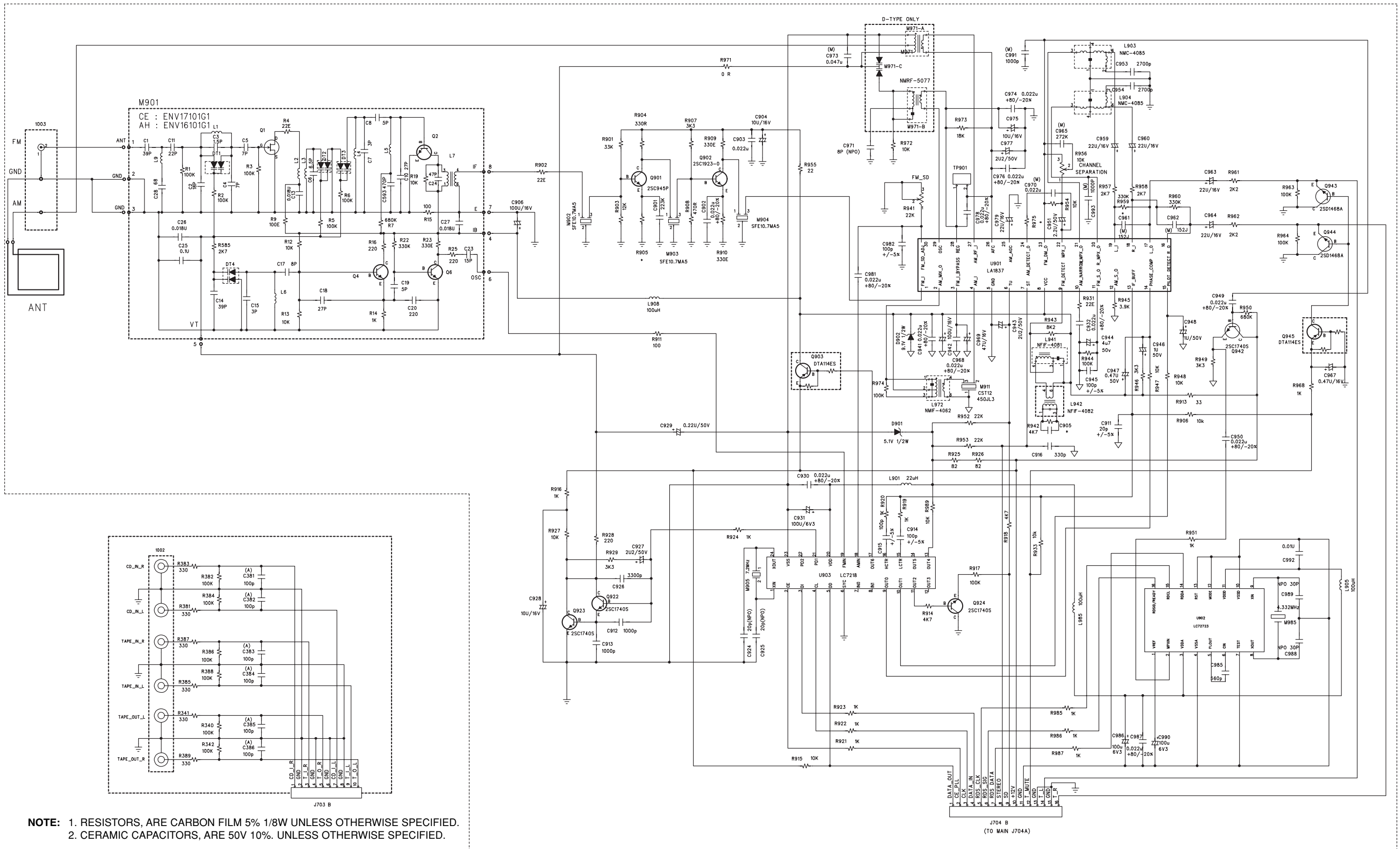

S-VIDEO

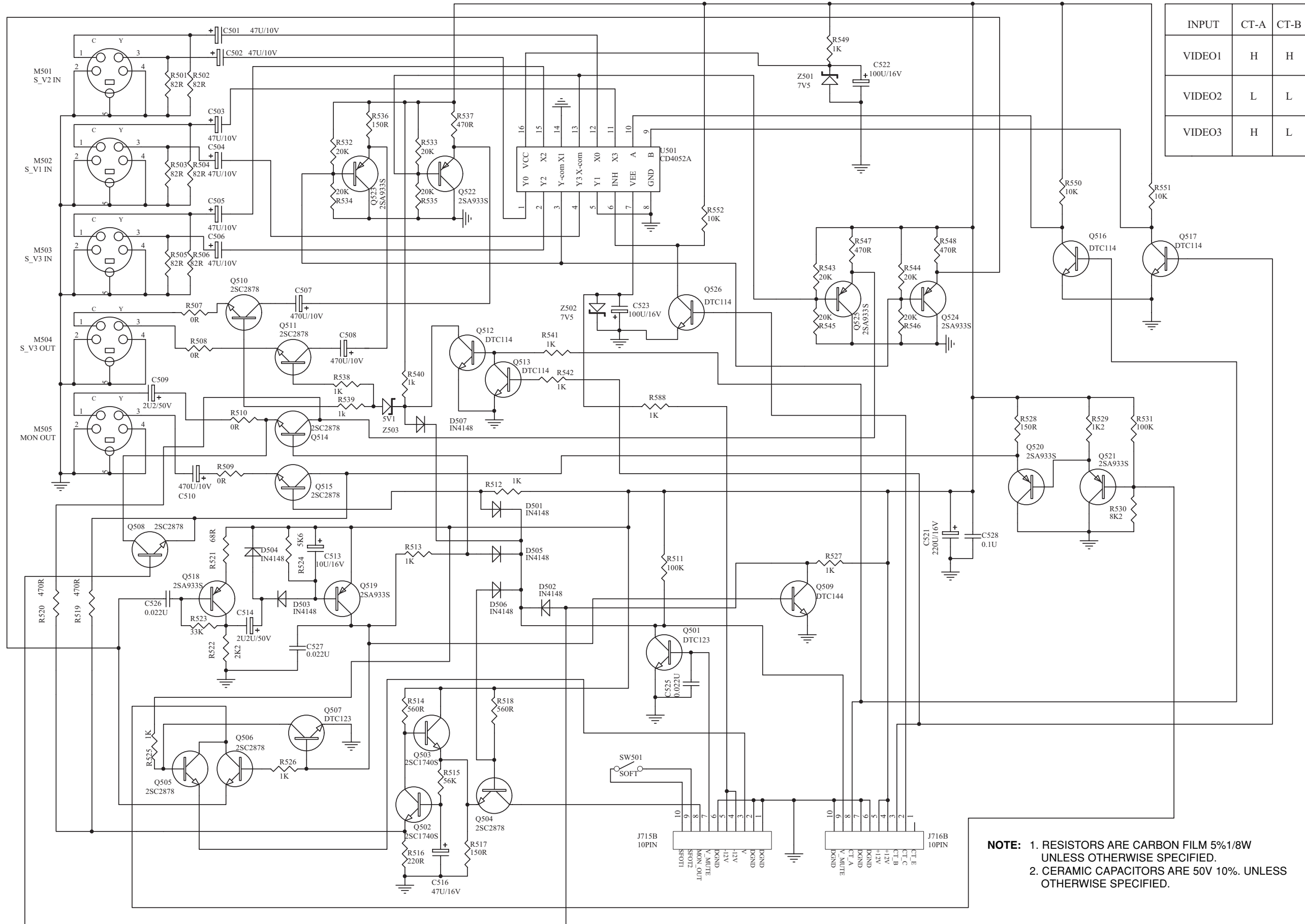

INPUT	CT-A	CT-B
VIDEO1	H	H
VIDEO2	L	L
VIDEO3	H	L

**NOTE:** 1. RESISTORS ARE CARBON FILM 5%1/8W UNLESS OTHERWISE SPECIFIED.  
 2. CERAMIC CAPACITORS ARE 50V 10%. UNLESS OTHERWISE SPECIFIED.

# FRONT AMPLIFIER

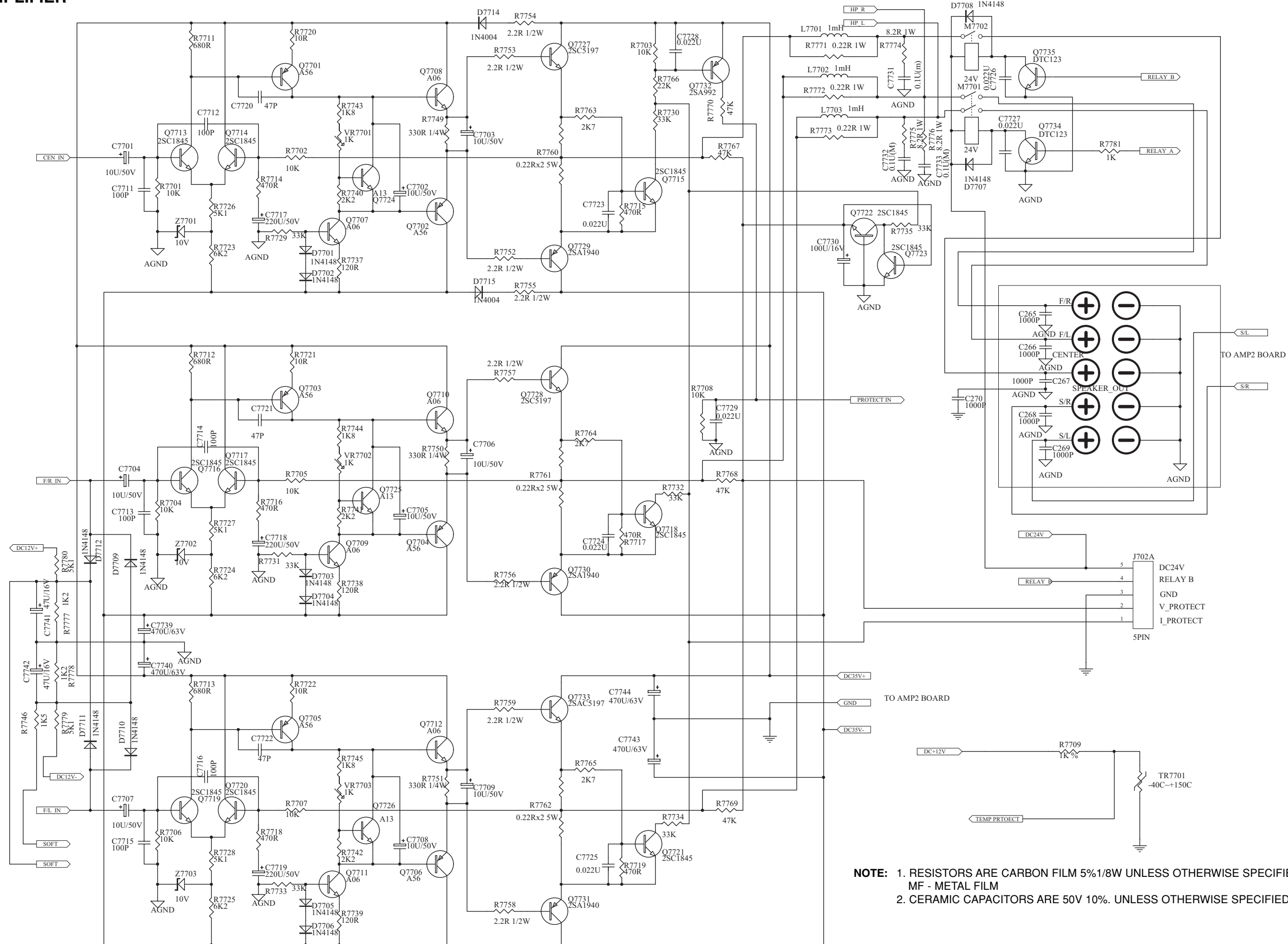

**NOTE:** 1. RESISTORS ARE CARBON FILM 5%/1/8W UNLESS OTHERWISE SPECIFIED.  
 MF - METAL FILM  
 2. CERAMIC CAPACITORS ARE 50V 10%. UNLESS OTHERWISE SPECIFIED.

**AUDIO**

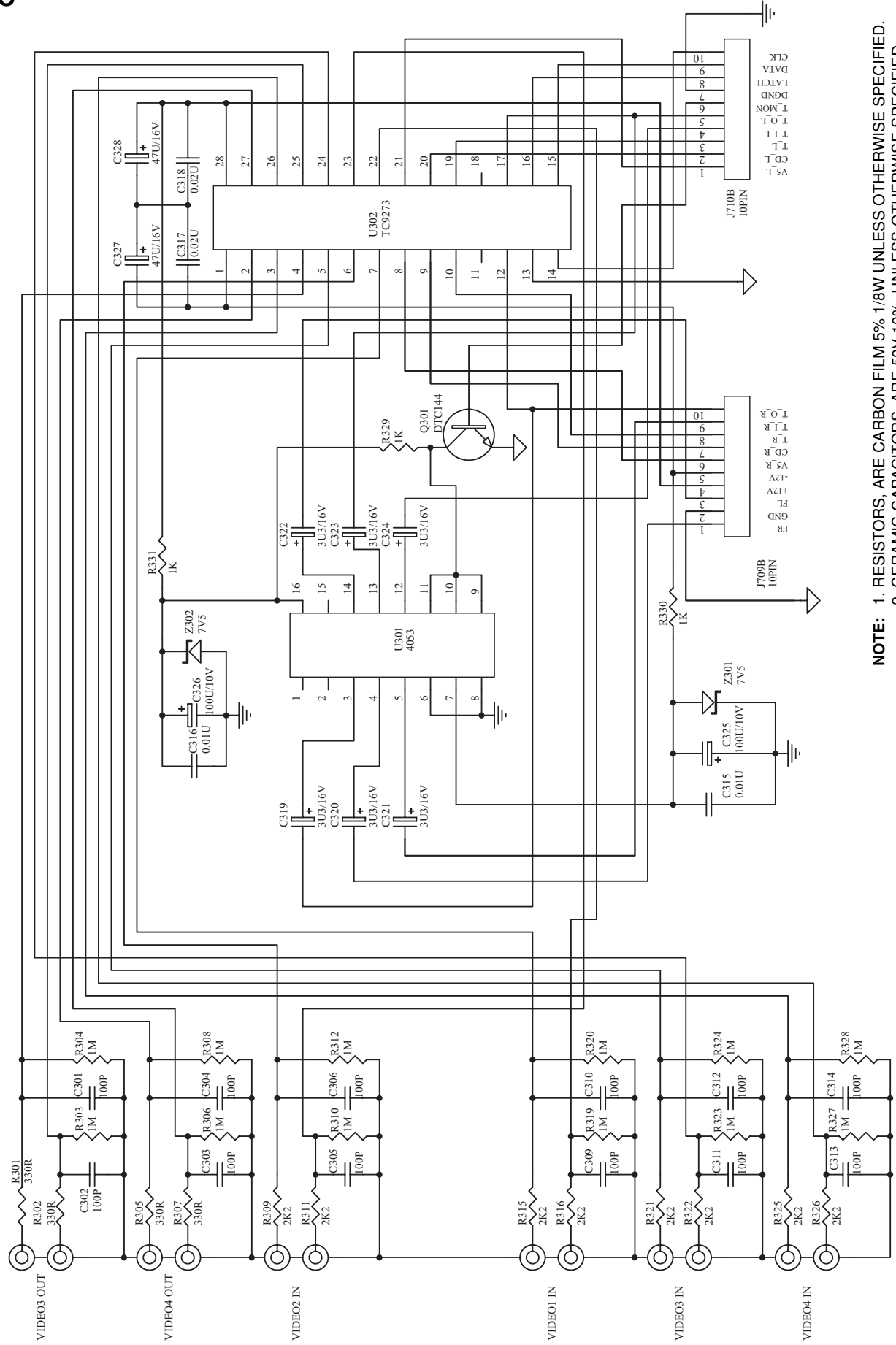

**NOTE:** 1. RESISTORS, ARE CARBON FILM 5% 1/8W UNLESS OTHERWISE SPECIFIED.  
2. CERAMIC CAPACITORS, ARE 50V 10%, UNLESS OTHERWISE SPECIFIED.

**VIDEO**

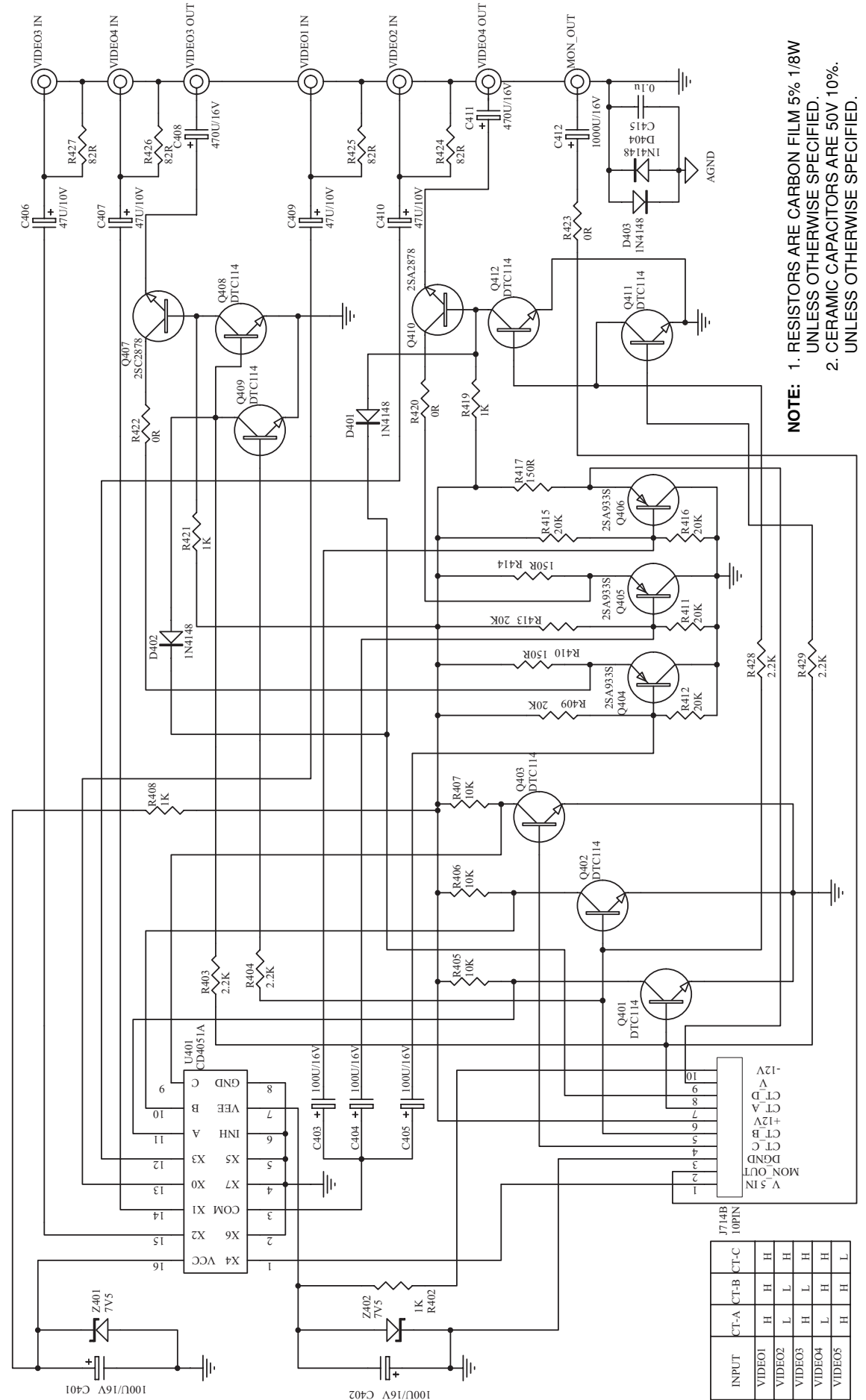

**NOTE:** 1. RESISTORS ARE CARBON FILM 5% 1/8W UNLESS OTHERWISE SPECIFIED.  
2. CERAMIC CAPACITORS ARE 50V 10%, UNLESS OTHERWISE SPECIFIED.

INPUT	CT-A	CT-B	CT-C
VIDEO1	H	H	H
VIDEO2	L	L	L
VIDEO3	L	L	H
VIDEO4	L	H	H
VIDEO5	H	H	L

# SURROUND AMPLIFIER

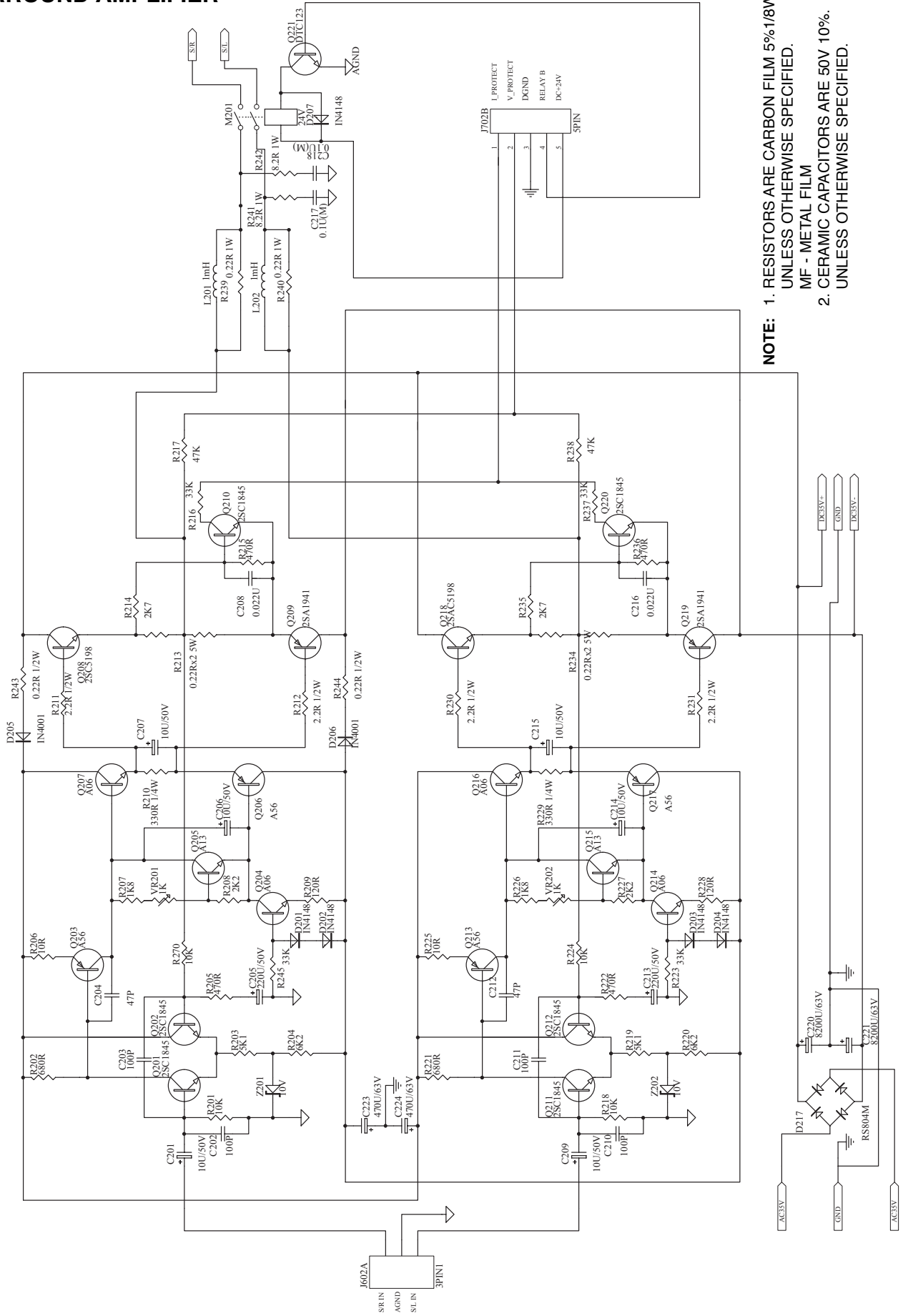

**NOTE:** 1. RESISTORS ARE CARBON FILM 5% 1/8W  
UNLESS OTHERWISE SPECIFIED.  
MF - METAL FILM  
2. CERAMIC CAPACITORS ARE 50V 10%.  
UNLESS OTHERWISE SPECIFIED.

# PSU

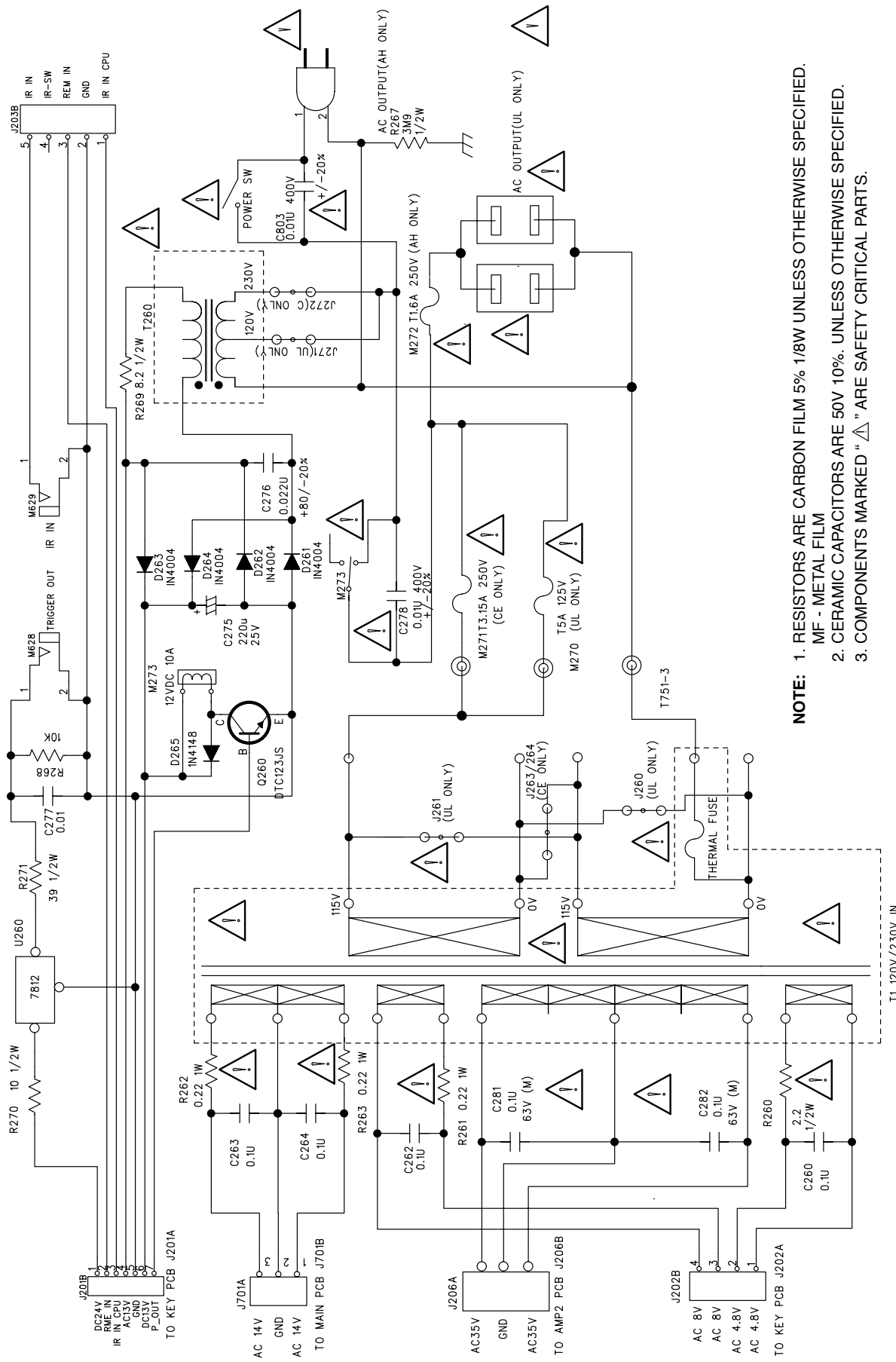

**NOTE:** 1. RESISTORS ARE CARBON FILM 5% 1/8W UNLESS OTHERWISE SPECIFIED.  
 MF - METAL FILM  
 2. CERAMIC CAPACITORS ARE 50V 10%, UNLESS OTHERWISE SPECIFIED.  
 3. COMPONENTS MARKED "Δ" ARE SAFETY CRITICAL PARTS.



# IC BLOCK DIAGRAM

**AC3 BOARD**  
**U101: 74HC153**

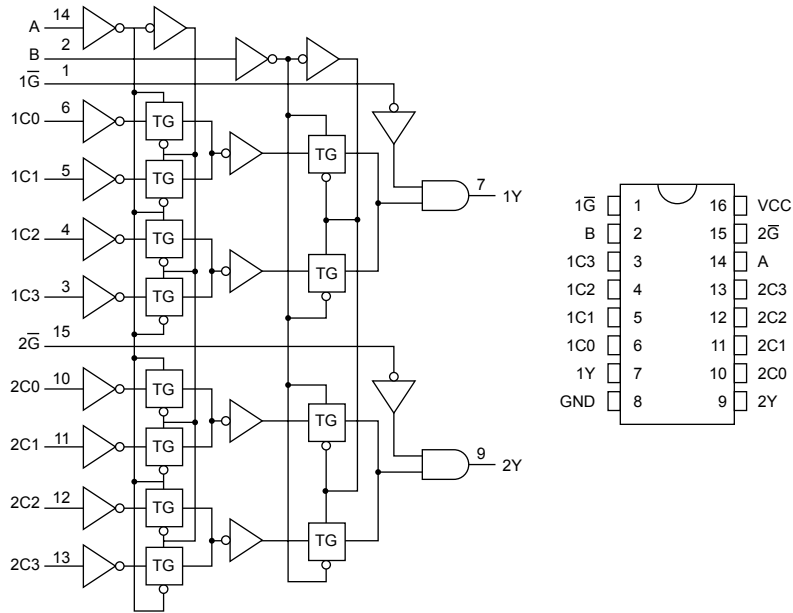

**AC3 BOARD**  
**U102: 74HC157**

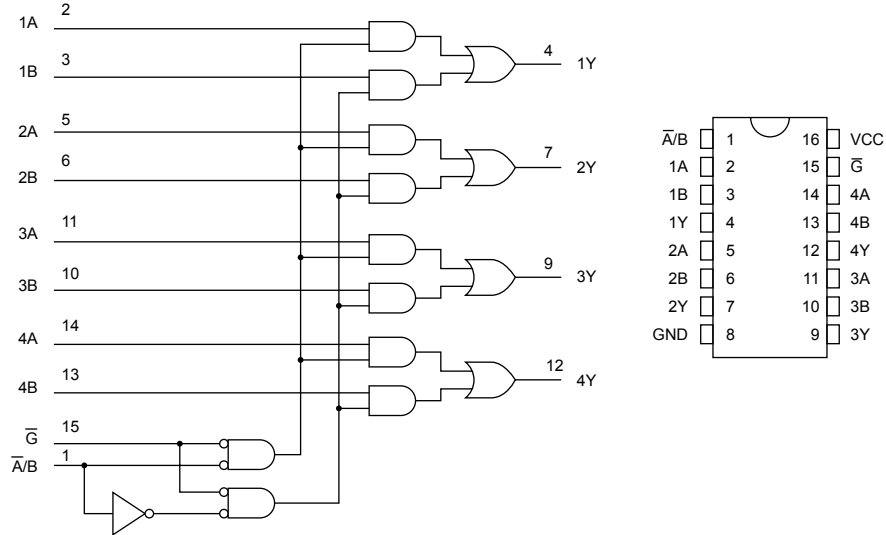

**AC3 BOARD**  
**U103: CS5333**

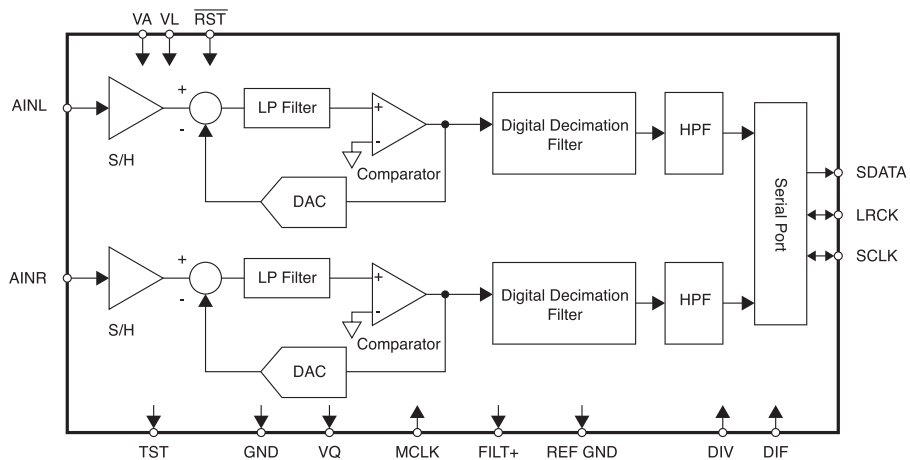

**AC3 BOARD**

**U104, U109, U116, U134: NJM5532**

**U131: NJM4558D**

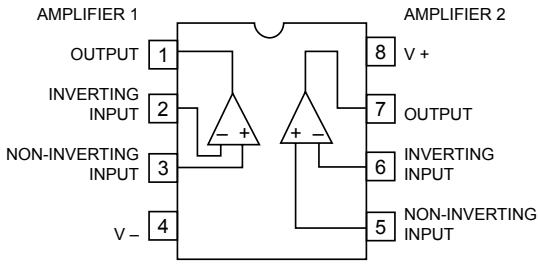

**AC3 BOARD**

**U108: AT27C040**

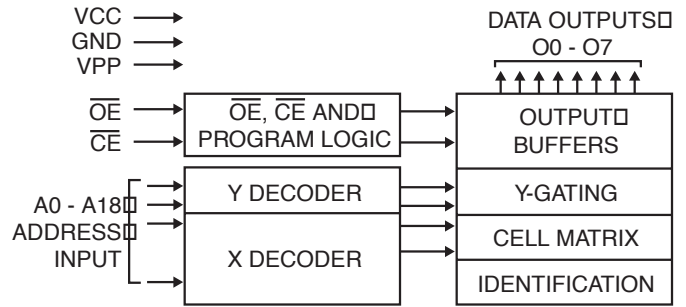

**AC3 BOARD**

**U105: CS4926**

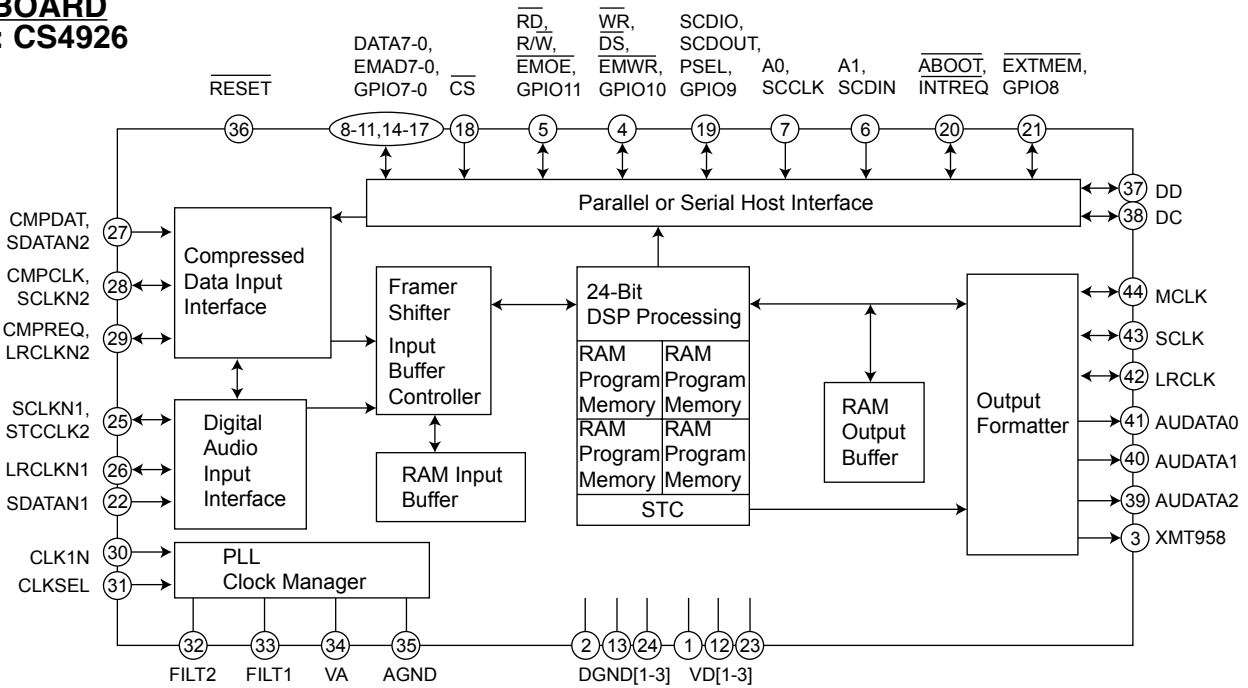

**AC3 BOARD**

**U106, U107: 74HC574**

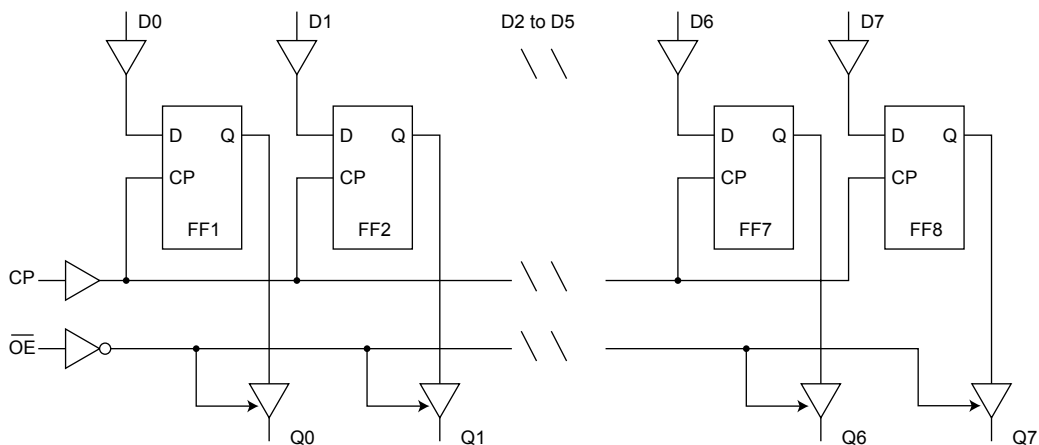

**AC3 BOARD**  
**U110: CS8414**

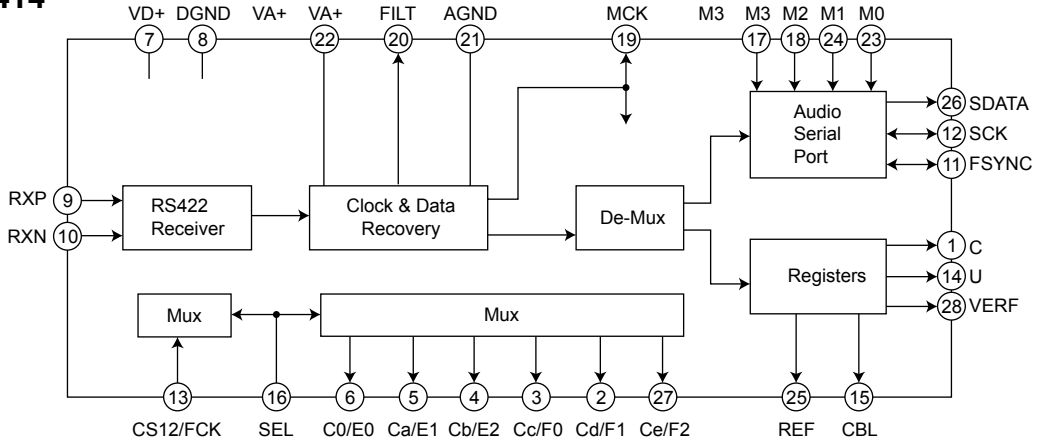

**AC3 BOARD**  
**U156: CS4360**

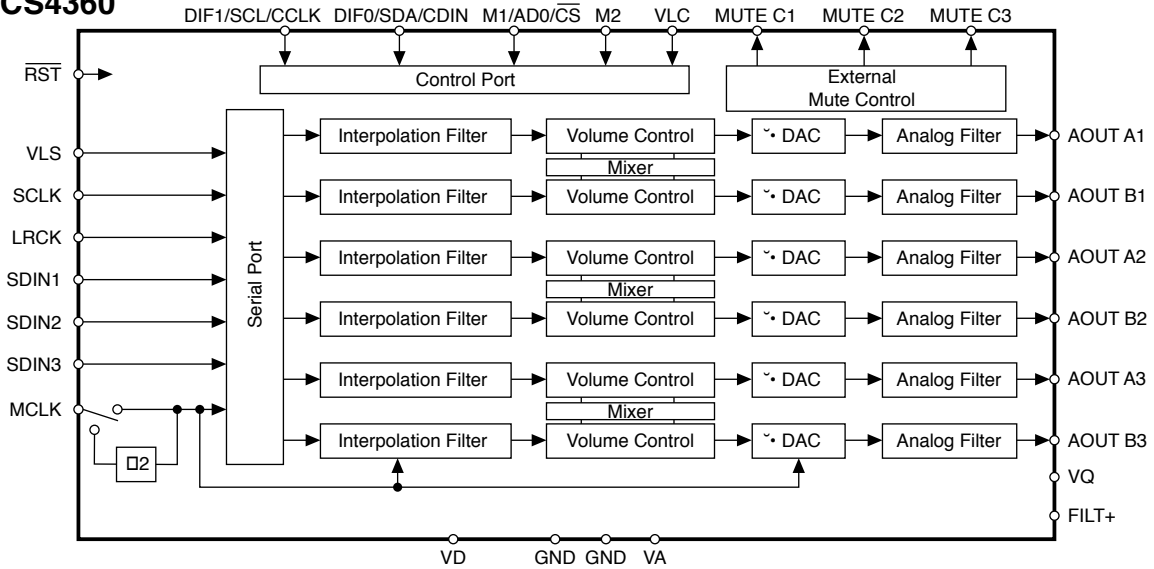

**AC3 BOARD**  
**U115, U117, U120: 74HC74**

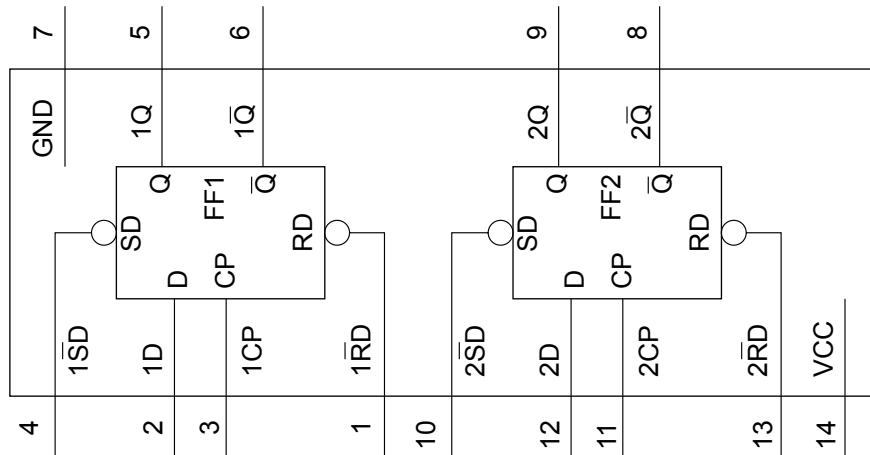

**AC3 BOARD**

**U114: 74HCU04**

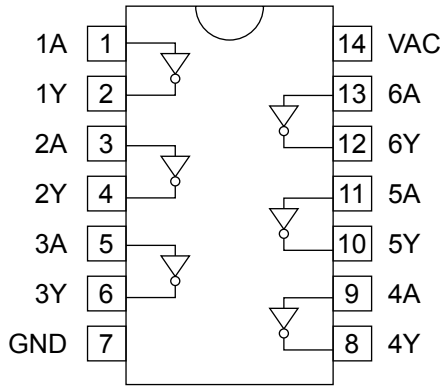

**AC3 BOARD**

**U118, U119: 74HC00**

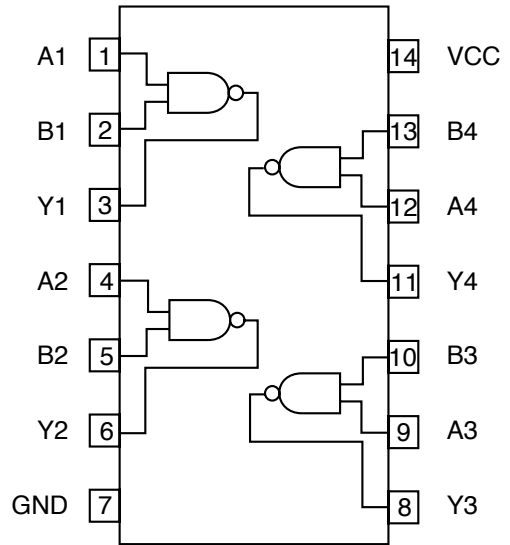

**AUDIO BOARD**

**U301: HCF4053BT**

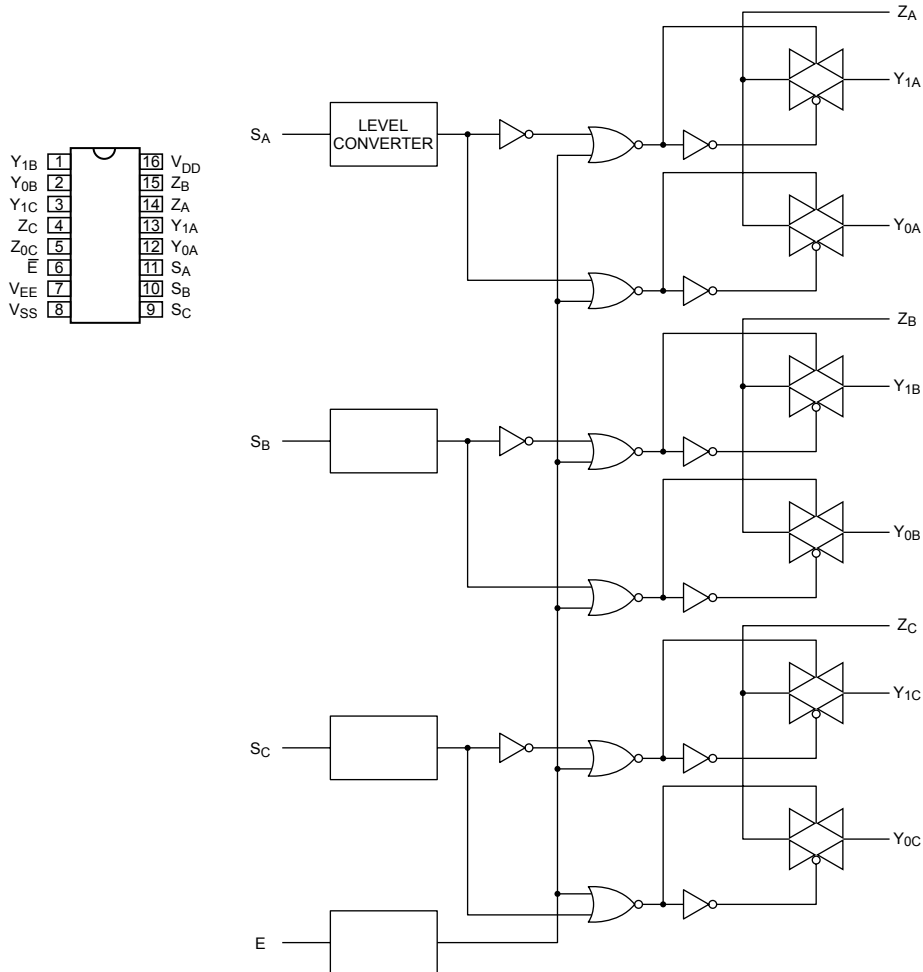

**AUDIO BOARD**  
**U302: TC9273N-004**

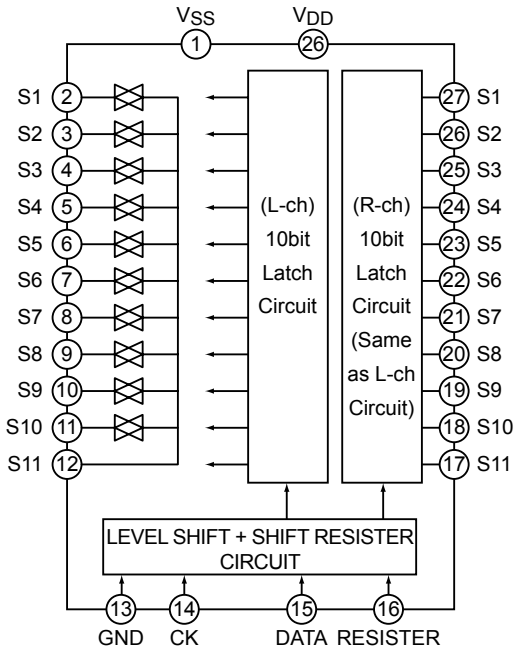

**DIGITAL BOARD**  
**U761: 74HCT00**

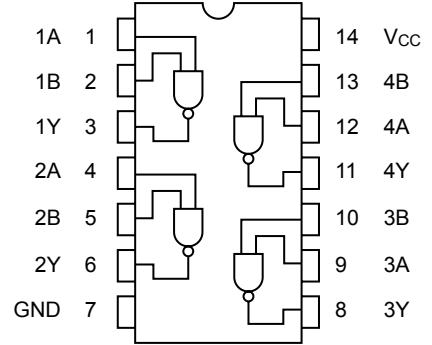

**KEY BOARD**  
**U201: LC87F65C8A**

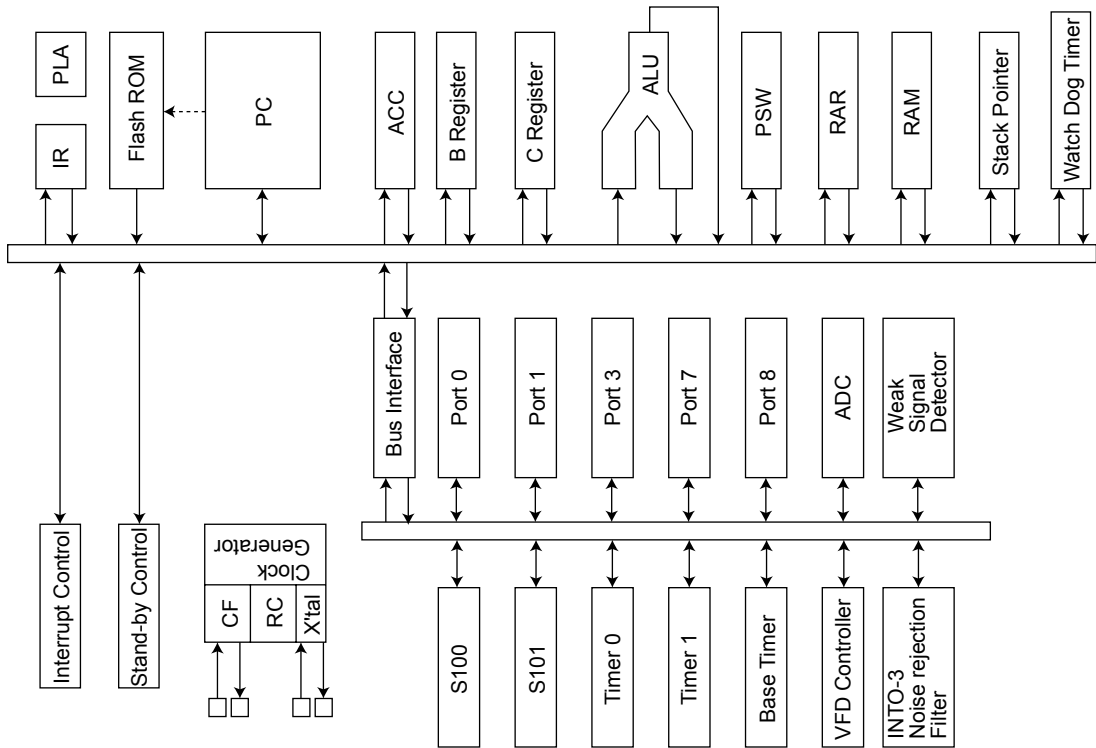

## KEY BOARD

### U202: EEPROM 24C02

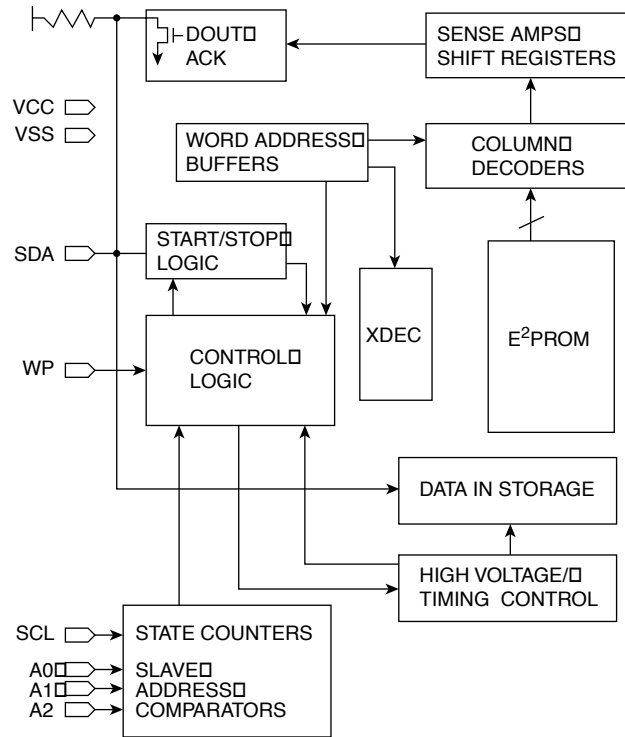
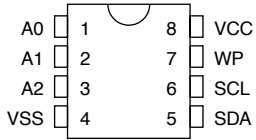

## MAIN BOARD

### U701: NJM5532M

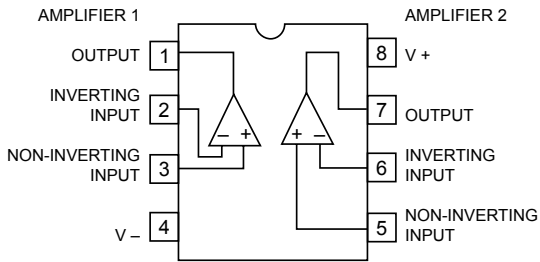

## MAIN BOARD

### U723: NJM78M56FA

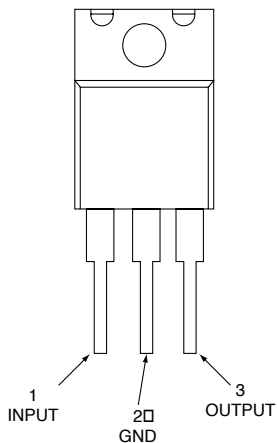

## MULTI-CHANNEL BOARD

### U605: M6244FP

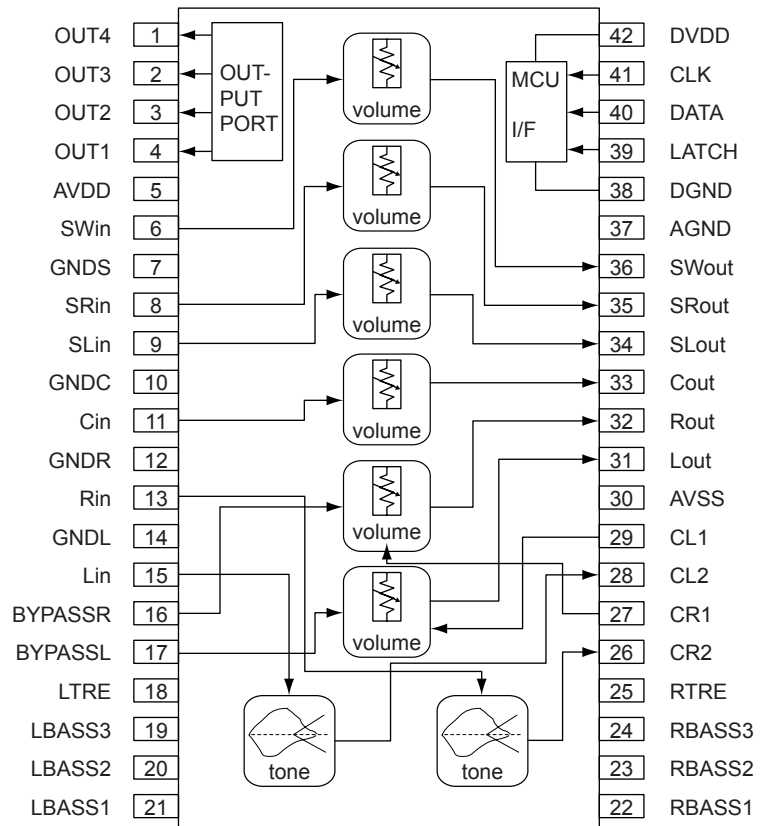

## MULTI-CHANNEL BOARD

U604: TC9164AN

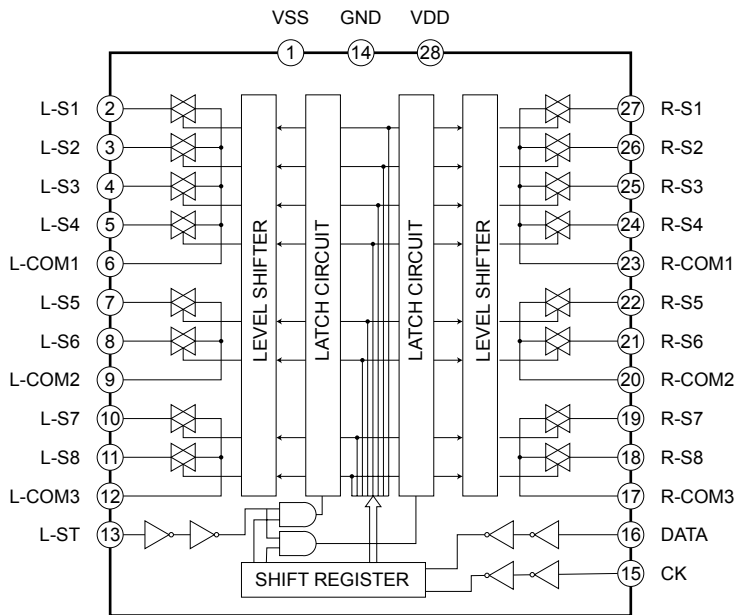

## MULTI-CHANNEL BOARD

U601, U602, U606, U607, U609: NJM5532

U603, U608: NJM4558D

U701-U703: NJM4558M

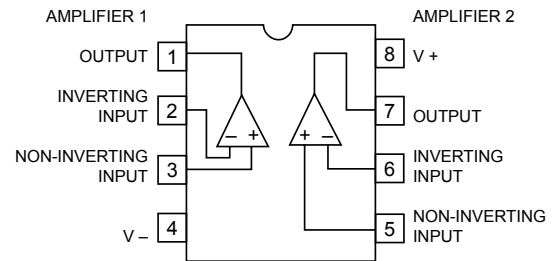

## TUNER BOARD

U901: LA1837

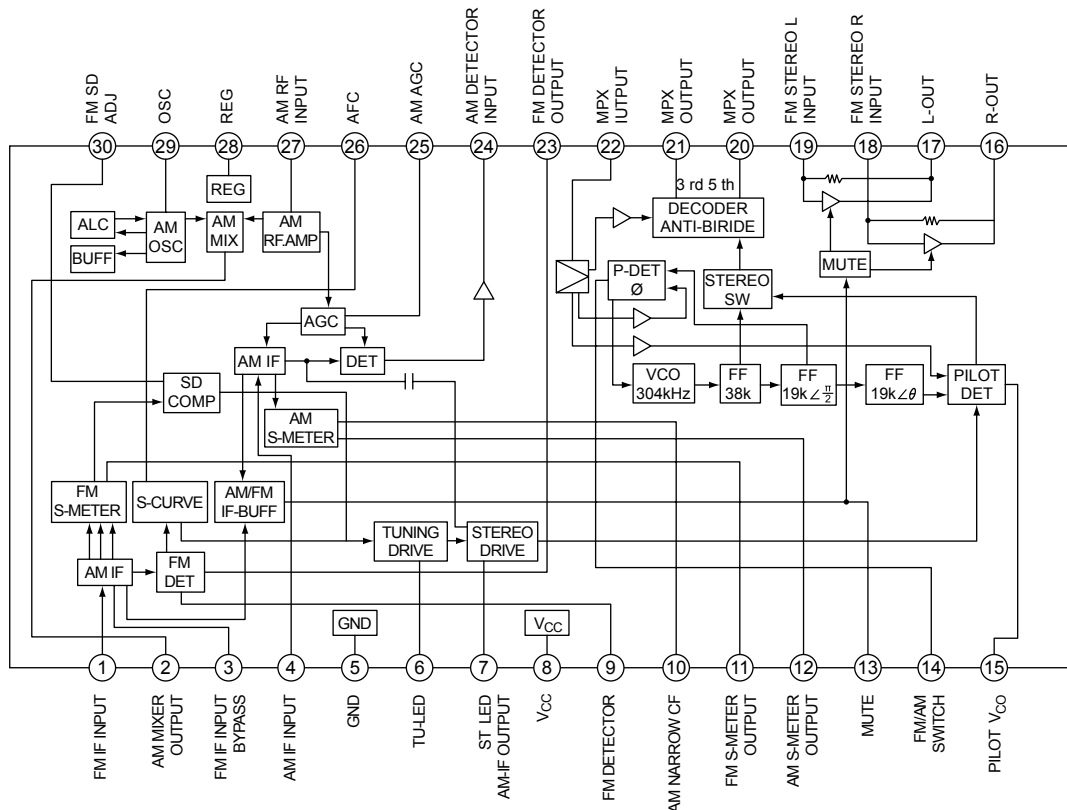

**TUNER BOARD**  
**U902: LC72723M**

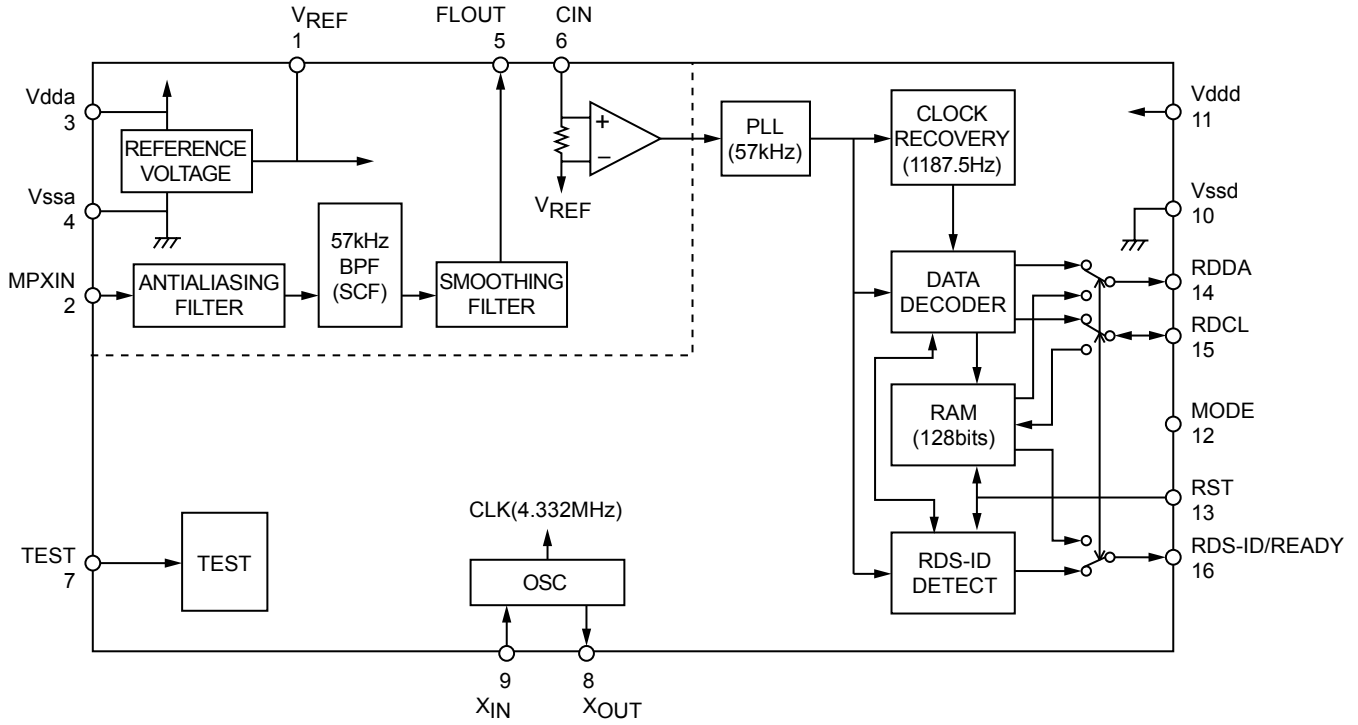

**TUNER BOARD**  
**U903: LC7218**

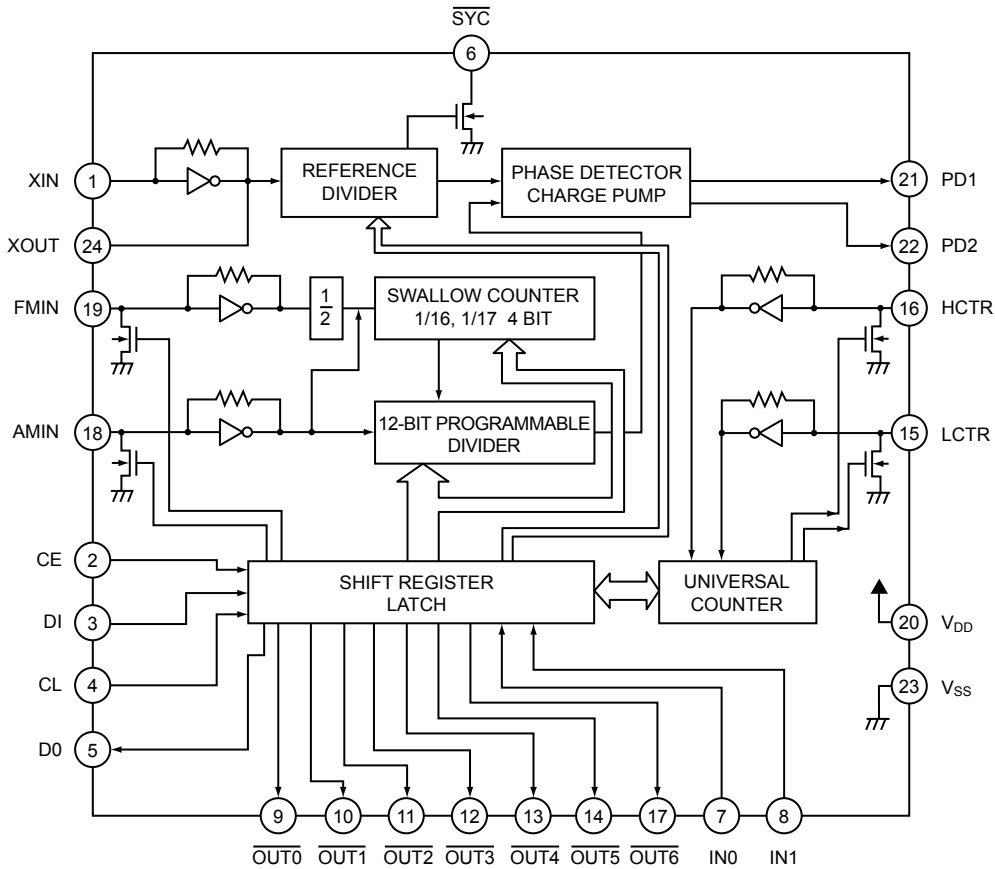



**S-VIDEO ASSEMBLY**  
**U501: 4052**

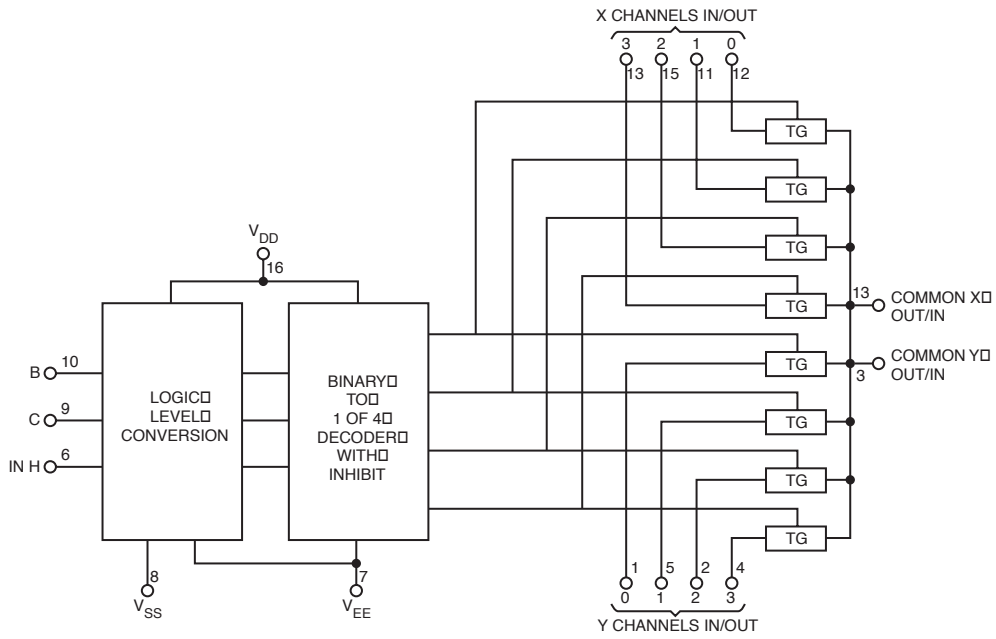

**VIDEO ASSEMBLY**  
**U401: MC14051**

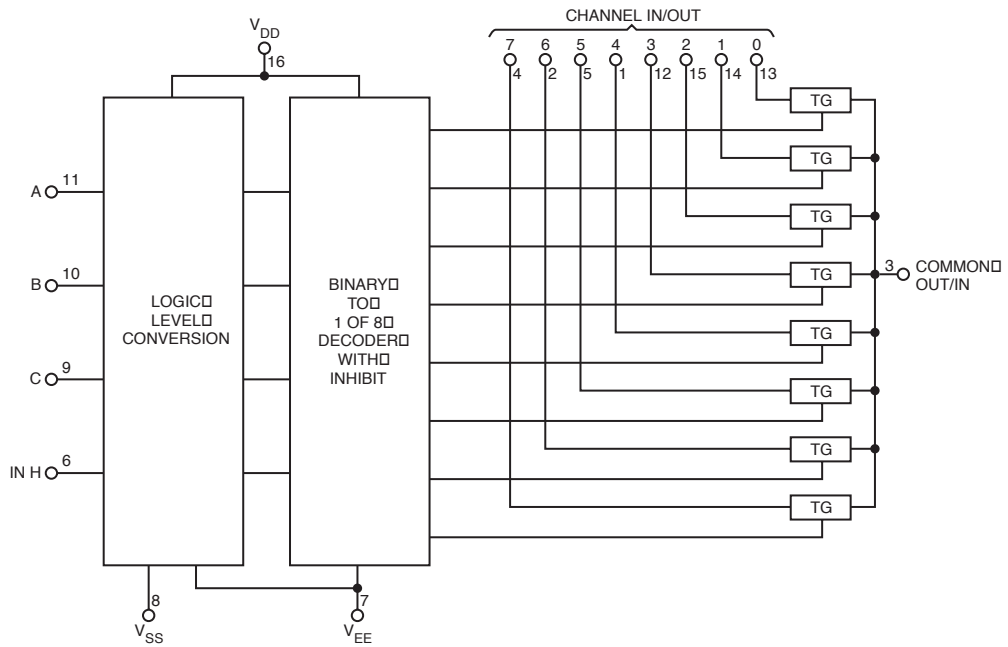

# ELECTRICAL PARTS LIST

Reference No.	Part No.	Description
<b>AC3 ASSY</b> <b>PC BOARD</b>	PCB-N0A40C-AC3	PCB ASSY AC3 N0A40C
<b>PCB</b> 1000	1725-570C-0000	PCB AC3 T742
<b>CAPACITOR</b> C1111,C1138,C1201,C1204,C1206,C1209, C1306,C136,C1405,C149 C102,C1112,C129,C138,C140,C142 C1133,C1135,C1139 C1205,C1208,C1302,C1303,C1401,C1402 C105,C152,C163,C164 C101,C103,C106,C108,C1122,C1123, C1131,C1132,C1134,C1136,C1137,C150, C151,C154,C157,C159,C166,C167, C169,C175,C179,C180,C183,C184, C193,C194,C198 C1110,C112,C1202,C1207,C1304,C1403 C113,C123,C1301,C1307,C1308,C133 C156 C172 C104 C153,C168 C199 C1118,C139 C165 C1106,C1107,C114,C115,C120,C121 C107 C1101,C1104,C1117,C1119,C1120,C1121, C117,C119,C132,C134,C145,C147 C158 C173,C176 C141,C143 C1140,C1141,C130 C161,C162 C1102,C1105,C171	150D-224K-J-BD 150E-104M-J-BD 150F-100J-J-BD 150F-102K-J-BD 150F-103K-J-BD 150F-104K-J-BD 150F-151K-J-BD 150F-682K-J-BD 150F-683M-J-BD 153F-225J-5-TOM 157C-108M-5-S5 157D-106M-5-GM 157D-106M-5-GMT 157D-107M-5-IU 157D-225M-5-GM 157D-226M-5-GM 157D-228M-5-W@T 157D-475M-5-EI 157D-476M-5-IU 157E-107M-5-LUT 157E-335M-5-GM 157F-105M-5-GM 15FD-105Z-J-BD 15FF-224Z-J-BD	CC 16V 0.22 $\mu$ F 10% 0805 CC 25V 0.1 $\mu$ F 20% 0805 CC 50V 10pF 5% 0805 1.2x CC 50V 1000pF 10% 0805 1 CC 50V 0.01 $\mu$ F 10% 0805 CC 50V 0.1 $\mu$ F 10% 0805 CC 50V 150pF 10% 0805 1. CC 50V 6800pF 10% 0805 1 CC 50V 0.068 $\mu$ F 20% 0805 CM 50V 2.2 $\mu$ F RL 10X8 CE 10V 1000 $\mu$ F 20% RL CE 16V 10 $\mu$ F 20% RL 4x7 CE 16V 10 $\mu$ F 20% RL 4x7 CE 16V 100 $\mu$ F 20% RL 5x11 CE 16V 2.2 $\mu$ F 20% RL 4X7 CE 16V 22 $\mu$ F 20% RL 4X7 CE 16V 2200 $\mu$ F 20% RL CE 16V 4.7 $\mu$ F 20% RL 3x5 CE 16V 47 $\mu$ F 20% RL 5x11 CE 25V 100 $\mu$ F 20% RL CE 25V 3.3 $\mu$ F 20% RL 4x7 CE 50V 1 $\mu$ F 20% RL 4x7 CC 16V 1 $\mu$ F +80-20% 0805 CC 50V 0.22 $\mu$ F +80/-20%
<b>COIL</b> L101-L103 L104	1801-100K-M 1807-273J-PS	COIL 10 $\mu$ H 10% BL7.0 COIL 27MH 5% 8.3X9.7
<b>WAFER/CONNECTOR</b> J203B	2101-1581-0	FLEXIBLE CONN. 35P

<b>Reference No.</b>	<b>Part No.</b>	<b>Description</b>
J604B	2102-031S-004	3 PIN ST. WAFER
J101A	2102-101S-004	WAFER 10P P2.5 ST.
J601B	2102-121S-004	12P ST.WAFER
<b>CRYSTAL</b>		
M101	2300-3060-0	X'TAL 12.288MHZ +/-20PPM
<b>SCREW</b>		
2704	2954-2606-0000	SCREWS BT 2.6X6
2702	2954-3008-0000	TAPPING 3X8MM B-TITE
<b>IC</b>		
U131	3130-0890-0	IC NJM4558D DUAL OP AMP.
U123	3130-2020-2	IC 7805 REG 5V
U125	3130-2020-3	IC 7805 REG 5V 1.5A
U121	3130-5610-0	IC LM317T+ADJ REGULATOR
U115,U117,U120	3130-6590-0	IC 74HC74 DUAL D-TYPE
U110	3130-8890-0	IC CS8414 DIR 96KHZ
U106,U107	3130-8980-0	IC 74HC574 8X D-TYPE
U104,U109,U116,U134	3130-9560-0	NJM5532 IC 'DIP8'
U105	3131-3720-0	IC CS4926 DSP CRYSTAL
U102	3131-3870-0	IC 74HC157 QUAD 2-INPUT
U101	3131-3980-0	IC 74HC153 QUAD 4-INPUT
U108	3131-7760-0	IC AT27C040 512KX8 OTP
U103	3131-8430-0	CS5333 24-BIT 96KHZ A/D
U156	3131-8450-0	IC CS4360-BS SOIC DIG TO
U118,U119	3131-9050-0	IC 74HC00 QUAD 2I/P NAND
U114	3131-9100-0	IC 74HCU04 HEX INVERTERS
	8910-0610-0	CRYSTAL IC KIT ASSY
<b>RESISTOR</b>		
R110	4707-103C-5-8	RCFA 1/2W 10K 2% RL 8 9P
R119,R1206,R122,R183,R187,R189	4720-000J-J	RMG 1/10W 0R 5% 0805
R140	4720-101J-J	RMG 1/10W 100R 5% 0805
R1207,R1209,R127,R129,R1304,R1308, R135,R136,R139,R1401,R1404,R169, R180,R185,R186,R198,	4720-102J-J	RMG 1/10W 1K 5% 0805
R101-R103,R105-R109,R111,R112,R126, R131,R134,R138,R150,R156,R157,R160, R161,R167,R168,R171,R182	4720-103J-J	RMG 1/10W 10K 5% 0805
R1302,R1405,R184,R190,R191,R192	4720-104J-J	RMG 1/10W 100K 5% 0805
R165	4720-121J-J	RMG 1/10W 120R 5% 0805
R123,R125,R130,R132,R133,R137, R158,R162	4720-151J-J	RMG 1/10W 150R 5% 0805
R166	4720-201J-J	RMG 1/10W 200R 5% 0805
R120,R1208,R1306,R1406,R181,R188	4720-203J-J	RMG 1/10W 20K 5% 0805
R163,R164	4720-223J-J	RMG 1/10W 22K 5% 0805

<b>Reference No.</b>	<b>Part No.</b>	<b>Description</b>
R194	4720-335J-J	RMG 1/10W 3.3M 5% 0805
R172	4720-471J-J	RMG 1/10W 470R 5% 0805
R121,R1301,R1305,R173,R197,R199	4720-472J-J	RMG 1/10W 4.7K 5% 0805
R1101,R113,R116	4720-473J-J	RMG 1/10W 47K 5% 0805
R104	4720-680J-J	RMG 1/10W 68R 5% 0805
R115,R118	4720-750J-J	RMG 1/10W 75R 5% 0805
R114,R117	4720-821J-J	RMG 1/10W 820R 5% 0805
R155,R159	4720-822J-J	RMG 1/10W 8.2K 5% 0805
<b>DIODE</b>		
D101	4840-0490-0	BRIDGE RECTIFIER RB152
<b>TRANSISTOR</b>		
Q101	485C-114E-5	TR DTC114ES
<b>HEATSINK</b>		
H-U121	5400-0831-0	HEATSINK
H-U123	5400-9130-0	HEAT SINK FOR 7805 2438-
<b>MISCELLANEOUS</b>		
S-U121	3100-3551-0	SI INSULATOR 12X18
2703	4151-9931-0	INSULATION BUSHING
<b>ACO ASSY</b>		
<b>PC BOARD</b> (AH/TITANIUM AH)	PCB-N0A40C-ACO	PCB ASSY ACO N0A40C
<b>PCB</b>		
2000 (AH/TITANIUM AH)	1725-572C-0101	PCB SPK PHO SEC PRI PSU
<b>INLET</b>		
(AH/TITANIUM AH)	2113-1662-0	AC INLET 2 PIN 15A
<b>AMP2 ASSY</b>		
<b>PC BOARD</b>		
(AH/TITANIUM AH)	PCB-N0A4XC-AMP2	PCB ASSY AMP2 T742(UL)
(CE/TITANIUM CE)	PCB-N0A40C-AMP2	PCB ASSY SL/SR POWER AMP
<b>PCB</b>		
<b>2000</b>	1725-572C-0101	PCB SPK PHO SEC PRI PSU
<b>CAPACITOR</b>		
C202,C203,C210,C211	150F-101K-2-FC	CC 50V 100pF 10% AT 3.5x
C208,C216	150F-223K-2-FD	CC 50V 0.022 $\mu$ F 10% AT
C204,C212	150F-470K-2-GD	CC 50V 47P 10% AT
C217,C218	153F-104J-5-QUN	CM 50V 0.1 $\mu$ F RL (9X11)

<b>Reference No.</b>	<b>Part No.</b>	<b>Description</b>
C205,C213 C201,C206,C207,C209,C214,C215 C223,C224 C220,C221	157C-227M-5-KW 157F-106M-5-IUE 157I-477M-5-W&A 8910-0112-0	CE 10V 220 $\mu$ F 20% RL 6x12 CE 50V 10 $\mu$ F 20% RL 5X11 CE 63V 470 $\mu$ F 20% RL 12.5 CE 63V 8200 $\mu$ F 20% RL
<b>COIL</b> L201,L202	1804-0540-0	SPRING COIL 1MH
<b>WAFER</b> M704B J602A J702B	2101-9400-0 2102-031S-004 2102-051S-004	JM2422-3M WAFER 3 PIN ST. WAFER 5P ST.WAFER
<b>RELAY</b> M201	4500-0910-0	RELAY 24VDC,125VA,3A
<b>RESISTOR</b> R206,R225 R201,R218,R224,R270 R209,R228 R207,R226 R208,R227 R214,R235 R216,R223,R237,R245 R205,R215,R222,R236 R217,R238 R203,R219 R204,R220 R202,R221 R210,R229 R211,R212,R230,R231 R243,R244 (AH/TITANIUM AH) R241,R242 R239,R240 R243,R244 (CE/TITANIUM CE) R213,R234	4701-100J-C 4701-103J-C 4701-121J-C 4701-122J-C 4701-222J-C 4701-272J-C 4701-333J-C 4701-471J-C 4701-473J-C 4701-512J-C 4701-622J-C 4701-681J-C 4705-331J-2 4717-2R2J-2 4717-680J-1 4718-8R2J-2-X 4718-R22J-2 4718-R22J-2 474B-R22K-5-02	RCF 1/8W 10R 5% ATS RCF 1/8W 10K 5% ATS RCF 1/8W 120R 5% ATS RCF 1/8W 1.2K 5% ATS RCF 1/8W 2.2K 5% ATS RCF 1/8W 2.7K 5% ATS RCF 1/8W 33K 5% ATS RCF 1/8W 470R 5% ATS RCF 1/8W 47K 5% ATS RCF 1/8W 5.1K 5% ATS RCF 1/8W 6.2K 5% ATS RCF 1/8W 680R 5% ATS RCF 1/4W 330R 5% AT RMF 1/2W 2.2R 5% AT RMF 1/2W 68R 5% AL RMF 1W 8.2R 5% AT RMF 1W 0.22R 5% AT RMF 1W 0.22R 5% AT RWR 5W 0.22R X2 10% RL
<b>SVR</b> VR201,VR202	4756-1026-3-06	SVR 1K H3 7X7.6 RH0615C
<b>DIODE</b> D205,D206 D201-D204,D207 Z201,Z202 D217	4804-0010-2 4804-1480-C 4837-10V6-2 4840-7060-0	DIODE 1N4001 AT DIODE 1N4148 ATS DZ 1/2W 10V TEMIC AT DIODE BRIDGE RS804M

<b>Reference No.</b>	<b>Part No.</b>	<b>Description</b>
<b>TRANSISTOR</b>		
Q221	485C-123J-5	TR DTC123JSA ROHM
Q201,Q202,Q210-Q212,Q220	4860-0190-5	TR 2SC 1845 (F.E) RL
Q208,Q218	4860-5210-5	TR 2SC5198-0 HFE 80-160
Q209,Q219	4860-5220-5	TR 2SA1941-0 HFE 80-160
Q204,Q207,Q214,Q216	4860-8890-0	TR MPS A06 VCE 80V NS
Q205,Q215	4860-8900-0	TR MPS A13 VCE 100V
Q203,Q206,Q213,Q217	4860-8910-0	TR MPS A56 VCE 80V NS
<b>WIRE</b>		
J206B	7012-6205-1	WIRE CON ASSY 3P P=3.96
JP211	7012-6224-1	WIRE CON ASSY 4P P=3.96
<b>AUDIO ASSY</b>		
<b>PC BOARD</b>		
	PCB-N0A40C-AUD	PCB ASSY AUDIO N0A40C
<b>PCB</b>		
3000	1725-571C-0000	PCB AVD/MUTI/TUN/VD/SVD
<b>CAPACITOR</b>		
C301-C306,C309-C314	150F-101K-2-FC	CC 50V 100pF 10% AT 3.5x
C315,C316	150F-103K-5-II	CC 50V 0.01 $\mu$ F 10% RL 5x5
C317,C318	150F-223K-2-FD	CC 50V 0.022 $\mu$ F 10% AT
C325,C326	157D-107M-5-IU	CE 16V 100 $\mu$ F 20% RL 5x11
C319-C324	157D-335M-5-II	CE 16V 3.3 $\mu$ F 20% RL 5x5
C327,C328	157D-476M-5-IU	CE 16V 47 $\mu$ F 20% RL 5x11
<b>SOCKET</b>		
J709B,J710B	2101-1801-0	SOCKET (PCB/PCB) 10P
<b>JACK</b>		
M301,M302	2113-1677-0	6P RCA JACK R/W NI
<b>IC</b>		
U301	3130-3870-0	IC HCF4053BT
U302	3131-3570-0	IC TC9273N-004 ANALOG
<b>RESISTOR</b>		
R329-R331	4701-102J-C	RCF 1/8W 1K 5% ATS
R303,R304,R306,R308,R310,R312, R319,R320,R323,R324,R327,R328	4701-105J-C	RCF 1/8W 1M 5% ATS
R309,R311,R315,R316, R321,R322,R325,R326	4701-222J-C	RCF 1/8W 2.2K 5% ATS
R301,R302,R305,R307	4701-331J-C	RCF 1/8W 330R 5% ATS

<b>Reference No.</b>	<b>Part No.</b>	<b>Description</b>
<b>DIODE</b> Z301,Z302	4837-7B51-2	DZ 1/2W 7.07~7.45V ROHM
<b>TRANSISTOR</b> Q301	485C-144E-5	TR DTC144ES ROHM
<b>DIG ASSY</b> <b>PC BOARD</b>	PCB-N0A40C-DIG	PCB ASSY DIG N0A40C
<b>PCB</b>	1725-634A-0000	PCB DIGITAL N0A40C
<b>CAPACITOR</b> C702,C707	150F-102K-2-FC	CC 50V 1000pF 10% AT 3.5
C703	150F-103K-2-FC	CC 50V 0.01 $\mu$ F 10% AT 3.5
C706,C763,C764	150F-104K-2-FC	CC 50V 0.1 $\mu$ F 10% AT
C705	150F-151J-5-GG	CC 50V 150P 5% RL 4X4
C765,C766	150F-223K-2-FD	CC 50V 0.022 $\mu$ F 10% AT
C705	150F-471J-5-OF	CC 50V 470pF 5% RL 8x3.5
C709	157C-107M-5-IM	CE 10V 100 $\mu$ F 20% RL 5X7
<b>COIL</b> R726	1801-220K-M	COIL 22 $\mu$ H 10% AL BL7
L701	1807-273J-PS	COIL 27MH 5% 8.3X9.7
<b>WAFER</b> J101B	2102-101S-004	WAFER 10P P2.5 ST.
<b>JACK</b> 1063,1064	2113-1311-0	1P RCA JACK BK NI
<b>IC</b> U701	3130-4990-0	IC LM393D DUAL VOLTAGE
<b>RESISTOR</b> R702	4701-102J-C	RCF 1/8W 1K 5% ATS
R703,R705,R707,R709, R715,R722,R723	4701-103J-C	RCF 1/8W 10K 5% ATS
R708,R711	4701-104J-C	RCF 1/8W 100K 5% ATS
R706	4701-152J-C	RCF 1/8W 1.5K 5% ATS
R704,R712	4701-182J-C	RCF 1/8W 1.8K 5% ATS
R714	4701-222J-C	RCF 1/8W 2.2K 5% ATS
R701	4701-471J-C	RCF 1/8W 470R 5% ATS
R713	4701-683J-C	RCF 1/8W 68K 5% ATS

<b>Reference No.</b>	<b>Part No.</b>	<b>Description</b>
<b>DIODE</b> D701	4837-4B71-2	DZ 1/2W 4.55~4.80V ROHM
<b>TRANSISTOR</b> Q702,Q703	4851-9230-5	TR 2SC1923-0 HFE 70-140
<b>WIRE</b> J203A	7705-1080-2004	CONN.ASSY AWG26 5P P2.5
<b>MISCELLANEOUS</b> 1062,1065	4811-F32R-3	LIGHT RX UNIT GPIF32R
<b>KEY ASSY</b> <b>PC BOARD</b>	PCB-N0A40C-KEY	PCB ASSY KEY N0A40C
<b>PCB</b> 2000	1725-569B-0000	PCB KEY/SWITCH/VOL/LED
<b>CAPACITOR</b> C202	150F-103K-5-II	CC 50V 0.01 $\mu$ F 10% RL 5x5
C205,C207	150F-104Z-5-IU	CC 50V 0.1 $\mu$ F +80/-20% RL
C203,C204	150F-220K-5-GG	CC 50V 22pF 10% RL 4x4
C201	157B-107M-5-KM	CE 6.3V 100 $\mu$ F 20% RL 6x7
C206	157B-227M-5-KW	CE 6.3V 220 $\mu$ F 20% RL
C208,C210,C212	157D-476M-5-IU	CE 16V 47 $\mu$ F 20% RL 5x11
C209	157E-335M-5-GM	CE 25V 3.3 $\mu$ F 20% RL 4x7
<b>COIL</b> L201	1801-220K-M	COIL 22 $\mu$ H 10% AL BL7
<b>CONNECTOR</b> J203A,J206A	2101-1581-0	FLEXIBLE CONN. 35P
<b>CRYSTAL</b> M219	2300-3150-0	CRYSTAL 10MHZ +/-30PPM
<b>IC</b> U201	MCU-N0A40C-FLASH	MCU ASSY N0A40C FLASH
U202	3131-3920-0	IC EEPROM 24C02 2KBIT
<b>RESISTOR</b> J2049,R224,R280	4701-102J-C	RCF 1/8W 1K 5% ATS
R283	4701-103J-2	RCF 1/8W 10K 5% AT
R215-R218,R225-R246,R251-R261, R287,R288	4701-103J-C	RCF 1/8W 10K 5% ATS
R263-R274	4701-104J-C	RCF 1/8W 100K 5% ATS



<b>Reference No.</b>	<b>Part No.</b>	<b>Description</b>
R207,R208,R209	4701-182J-C	RCF 1/8W 1.8K 5% ATS
R210,R211,R212	4701-222J-C	RCF 1/8W 2.2K 5% ATS
R228-R231,R262	4701-223J-C	RCF 1/8W 22K 5% ATS
R284	4701-392J-2	RCF 1/8W 3.9K 5% AT
R220,R221	4701-471J-C	RCF 1/8W 470R 5% ATS
J213,R213,R214,R219	4701-472J-C	RCF 1/8W 4.7K 5% ATS
R222,R247,R248,R249,R250	4701-473J-C	RCF 1/8W 47K 5% ATS
R223	4701-474J-C	RCF 1/8W 470K 5% ATS
R275	4701-562J-C	RCF 1/8W 5.6K 5% ATS
R201-R203	4701-681J-C	RCF 1/8W 680R 5% ATS
R204-R206	4701-821J-C	RCF 1/8W 820R 5% ATS
<b>DIODE</b>		
D212	4804-0010-2	DIODE 1N4001 AT
D201,D202,D205,D206,D209,D210,D213	4804-1480-C	DIODE 1N4148 ATS
D214	4837-4C20-2	DZ 1/2W 5.0-5.2V AT
D203,D211	4837-5B61-2	DZ 1/2W 5.45-5.73 ROHM
<b>TRANSISTOR</b>		
Q203	485C-114E-5	TR DTC114ES
Q202	485C-144E-5	TR DTC144ES ROHM
Q201	4860-0050-5	TR SS8050 C/D SAMSUNG RL
<b>SWITCH</b>		
M201-M217,M222	5200-3538-0	SWITCH, TACT SKHHBY 7MM
<b>WIRE</b>		
J208B	7702-1120-2004	WIRE CON ASSY 2P P=2.5
J207A	7703-1150-2004	WIRE CON ASSY 3P P=2.5
J202A	7704-1200-2004	CN ASSY 4P P=2.5 L=200
J201A	7707-1500-2004	7P CONN WIRE ASSY L=500
<b>MISCELLANEOUS</b>		
2119	2460-1890-2	VFD 12-MT-84GNK FUTABA
M218	4132-1061-0	SOLDER TAG
2118	4152-5741-0	HOLDER (FL)
M218	4814-3TE2-3	IR SENSOR PIC-12043TE2
<b>LED ASSY</b>		
<b>PC BOARD</b>	PCB-N0A40C-LED	PCB ASSY LEDBOARD N0A40C
<b>PCB</b>		
2000	1725-569B-0000	PCB KEY/SWITCH/VOL/LED
<b>WAFER</b>		
J208A	2102-8002-3-100	WAFER 2 PIN 9MM

<b>Reference No.</b>	<b>Part No.</b>	<b>Description</b>
<b>LED</b> D208	3700-2489-G	LED 3MM GREEN SP
<b>MAIN ASSY</b> <b>PC BOARD</b> (AH/TITANIUM AH) (CE/TITANIUM CE)	PCB-N0A4XC-MAIN PCB-N0A40C-MAIN	PCB ASSY MAIN T742(UL) PCB ASSY MAIN N0A40C
<b>PCB</b> 1000	1725-568C-0000	PCB MAIN N0A40C
<b>CAPACITOR</b> C7711-C7716 C701 C720,C721,C727,C730,C731,C7723-C7729 C7720-C7722 C7731-C7733 C7717-C7719 C7730 C7741,C7742 C718 C717 C722,C723,C732,C7701-C7710 C728,C729 C726 C7743,C7744 C7739,C7740	150F-101K-2-FC 150F-104K-2-FC 150F-223K-2-FD 150F-470J-2-FC 153F-104J-5-QUN 157C-227M-5-KW 157D-107M-5-IU 157D-476M-5-IM 157E-108M-5-X& 157E-338M-5-5\$ 157F-106M-5-GM 157F-107M-5-OW 157F-476M-5-IU 157I-477M-5-W&A 157I-477M-5-X&	CC 50V 100pF 10% AT 3.5x CC 50V 0.1 $\mu$ F 10% AT CC 50V 0.022 $\mu$ F 10% AT CC 50V 47PF 5% AT 3.5X2 CM 50V 0.1 $\mu$ F RL (9X11) CE 10V 220 $\mu$ F 20% RL 6x12 CE 16V 100 $\mu$ F 20% RL 5x11 CE 16V 47 $\mu$ F 20% RL 5X7 CE 25V 1000 $\mu$ F 20% RL CE 25V 3300 $\mu$ F 20% RL CE 50V 10 $\mu$ F 20% RL 4x7 CE 50V 100 $\mu$ F 20% RL 8x12 CE 50V 47 $\mu$ F 20% RL 5x11 CE 63V 470 $\mu$ F 20% RL 12.5 CE 63V 470 $\mu$ F 20% RL
<b>COIL</b> L7701,L7702,L7703	1804-0540-0	SPRING COIL 1MH
<b>WAFER/CONNECTOR</b> J206B J703A,J705A,J706A,J709A, J710A,J714A,J715A,J716A J704A J604A,J701B J401B M712,M713,M714	2101-1591-0 2101-1621-0  2101-1641-0 2102-031S-004 2102-111S-004 2113-1160-0	FLEXIBLE CONN. 35P P1.25 WAFER (PCB/PCB) 10P P2.0  WAFER (PCB/PCB) 16P P2.0 3 PIN ST. WAFER 11P ST.WAFER WAFER 2P ST. P=2.5 NH
<b>SCREW</b> 2705 2706	2954-2606-0000 2954-3008-0000	SCREWS BT 2.6X6 TAPPING 3X8MM B-TITE
<b>IC</b> U721,U7701	3130-2520-2	IC 7812H 12V REG, T0220F

<b>Reference No.</b>	<b>Part No.</b>	<b>Description</b>
U722	3130-3800-0	IC UPC79M12HF REGULATOR
U723	3130-8190-0	IC NJM78M56FA 5.6V
U701	3131-4850-0	IC NJM5532M JRC (SMD)
U726	3131-9110-0	IC 74HC08 AND GATES(SOP)
<b>RELAY</b>		
M7702	4500-0900-0	RELAY 24VDC,250VAC,10A
M7701	4500-0910-0	RELAY 24VDC,125VA,3A
<b>RESISTOR</b>		
R7720-R7722	4701-100J-C	RCF 1/8W 10R 5% ATS
R703,R705,R731,R7781	4701-102J-C	RCF 1/8W 1K 5% ATS
R7701-R7708	4701-103J-C	RCF 1/8W 10K 5% ATS
R704,R706	4701-104J-C	RCF 1/8W 100K 5% ATS
R7737,R7738,R7739	4701-121J-C	RCF 1/8W 120R 5% ATS
R7743-R7745,R7777,R7778	4701-122J-C	RCF 1/8W 1.2K 5% ATS
R756,R757	4701-123J-C	RCF 1/8W 12K 5% ATS
R7746	4701-152J-C	RCF 1/8W 1.5K 5% ATS
R7740,R7741,R7742	4701-222J-C	RCF 1/8W 2.2K 5% ATS
R7766	4701-223J-C	RCF 1/8W 22K 5% ATS
R7763,R7764,R7765	4701-272J-C	RCF 1/8W 2.7K 5% ATS
R732,R7729-R7735	4701-333J-C	RCF 1/8W 33K 5% ATS
R7714-R7719	4701-471J-C	RCF 1/8W 470R 5% ATS
R7767-R7770	4701-473J-C	RCF 1/8W 47K 5% ATS
R7726-R7779,R7780	4701-512J-C	RCF 1/8W 5.1K 5% ATS
R7723-R7725	4701-622J-C	RCF 1/8W 6.2K 5% ATS
R7711-R7713	4701-681J-C	RCF 1/8W 680R 5% ATS
R7709	4711-102A-2	RMF 1/8W 1K 1% AT
R7749-R7751	4715-331A-2	RMF 1/4W 330R 1% AT
R7752,R7753,R7756-R7759	4717-2R2J-C	RMF 1/2W 2.2R 5% ATS
R7754,R7755 (AH/TITANIUM AH)	4717-680J-1	RMF 1/2W 68R 5% AL
R733,R734	4718-391J-2-X	RMF 1W 390R 5% AT
R7774-R7776	4718-8R2J-2-X	RMF 1W 8.2R 5% AT
R7771-R7773	4718-R22J-2	RMF 1W 0.22R 5% AT
R7754,R7755 (CE/TITANIUM CE)	4718-R22J-2	RMF 1W 0.22R 5% AT
R7760-R7762	474B-R22K-5-02	RWR 5W 0.22R X2 10% RL
<b>SVR</b>		
VR7701-VR7703	4756-1026-3-06	SVR 1K H3 7X7.6 RH0615C
<b>DIODE</b>		
D723	4804-0010-2	DIODE 1N4001 AT
D701-D704,D719-D721,D7714,D7715	4804-0040-2	DIODE IN4004 AT
D730,D737,D7701-D7712	4804-1480-C	DIODE 1N4148 ATS
D715-D718	4805-3930-2	DIODE 1N5393 200V 1.5A
Z7701-Z7703	4837-10V6-2	DZ 1/2W 10V TEMIC AT
D722	4837-27V0-2	DZ 1/2W 27V(26.2-27.6)AT

<b>Reference No.</b>	<b>Part No.</b>	<b>Description</b>
<b>TRANSISTOR</b>		
Q7732	4850-992F-5	TR 2SA992 HFE 300-600
Q7734,Q7735	485C-123J-5	TR DTC123JSA ROHM
Q7713-Q7723	4860-0190-5	TR 2SC 1845 (F.E) RL
Q724	4860-0660-5	TR 2SA1015 (G.R.) RL
Q7727,Q7728,Q7733	4860-5210-5	TR 2SC5198-0 HFE 80-160
Q7729,Q7730,Q7731	4860-5220-5	TR 2SA1941-0 HFE 80-160
Q7707Q7712	4860-8890-0	TR MPS A06 VCE 80V NS
Q7724-Q7726	4860-8900-0	TR MPS A13 VCE 100V
Q7701-Q7706	4860-8910-0	TR MPS A56 VCE 80V NS
<b>HEATSINK</b>		
M702	5400-0831-0	HEATSINK
M701,M703	5400-1702-0	HEATSINK 23.5X17X50
<b>WIRE</b>		
M707A	7012-6203-1	WIRE CON ASSY 4P P=3.96
M704A	7012-6204-1	WIRE CON ASSY 3P P=3.96
M705A	7012-6206-1	WIRE CON ASSY 2P P=3.96
J702A	7705-1180-2004	WIRE CON ASSY 5P P=2.5
<b>MISCELLANEOUS</b>		
GND	4132-1061-0	SOLDER TAG
TR7701	8910-0491-0	NTC THERMISTOR 1K (B)
<b>MULTI ASSY</b>		
<b>PC BOARD</b>	PCB-N0A40C-MUTI	PCB ASSY MULTI CH N0A40C
<b>PCB</b>		
6000	1725-571C-0000	PCB AVD/MUTI/TUN/VD/SVD
<b>CAPACITOR</b>		
C601-C606,C644,C646,C651,C653, C658,C664,C671,C677	150F-101K-2-FC	CC 50V 100pF 10% AT 3.5x
C612	150F-103K-5-II	CC 50V 0.01 $\mu$ F 10% RL 5x5
C6103,C6104,C641	150F-104K-2-FC	CC 50V 0.1 $\mu$ F 10% AT
C643,C650,C657,C663,C666,C670, C673,C676	150F-221K-2-FC	CC 50V 220pF 10% AT 3.5x
C687,C688	150F-223K-2-FD	CC 50V 0.022 $\mu$ F 10% AT
C634,C637	153F-153J-5-KP	CM 50V 0.015 $\mu$ F 5% RL
C635,C638	153F-822J-5-KW	CM 50V 8200pF 5% RL 6x12
C623,C624,C660,C683-C686	157D-106M-5-IU	CE 16V 10 $\mu$ F 20% RL 5x11
C611,C614,C615,C625-C628	157D-226M-5-II	CE 16V 22 $\mu$ F 20% RL 5x5
C613	157D-227M-5-KW	CE 16V 220 $\mu$ F 20% RL 6x12
C633,C636	157D-334M-5-IU	CE 16V 0.33 $\mu$ F 20% RL 5X11

<b>Reference No.</b>	<b>Part No.</b>	<b>Description</b>
C617,C618,C639,C640,C642,C649, C655,C662,C669,C675	157D-335M-5-II	CE 16V 3.3 $\mu$ F 20% RL 5x5
C619-C622,C702,C706,C710,C712,C740 C629-C632,C681,C682	157D-475M-5-IU 157D-476M-5-IM	CE 16V 4.7 $\mu$ F 20% RL 5x11 CE 16V 47 $\mu$ F 20% RL 5X7
C6100,C6101	157F-106M-5-GM	CE 50V 10 $\mu$ F 20% RL 4x7
C645,C648,C652,C659,C661,C665, C668,C672,C678,C680	157F-106M-5-IU	CE 50V 10 $\mu$ F 20% RL 5x11
<b>COIL</b> L601,L602	1801-101K-M	COIL 100 $\mu$ H 10%
<b>WAFER/SOCKET</b> J705B,J706B J602A	2101-1801-0 2102-031S-004	SOCKET (PCB/PCB) 10P 3 PIN ST. WAFER
<b>JACK</b> M603,M604 M601,M602	2113-1310-0 2113-1678-0	2P RCA JACK BK/BK NI 4P RCA JACK R/W NI
<b>IC</b> U603,U608 U604 U701,U702,U703 U601,U602,U606,U607,U609 U605	3130-0890-0 3130-3730-1 3130-6060-0 3130-9560-0 3131-4910-1	IC NJM4558D DUAL OP AMP. IC TC9164AN HV ANALOG SW IC NJM4558M OP AMP NJM5532 IC 'DIP8' IC M62446AFP VOLUME/TONO
<b>RESISTOR</b> R6110,R6111,R638,R640,R641 R615,R616,R619,R620-R625 R602,R604,R606,R608, R610,R612,R632-R668	4701-102J-C 4701-103J-C 4701-104J-C	RCF 1/8W 1K 5% ATS RCF 1/8W 10K 5% ATS RCF 1/8W 100K 5% ATS
R626	4701-123J-C	RCF 1/8W 12K 5% ATS
R643,R651,R663,R673,R681,R693	4701-152J-C	RCF 1/8W 1.5K 5% ATS
R664	4701-153J-C	RCF 1/8W 15K 5% ATS
R6100,R659,R660,R670,R671,R689,R690	4701-202J-C	RCF 1/8W 2K 5% ATS
R628,R629	4701-203J-C	RCF 1/8W 20K 5% ATS
R669	4701-221J-C	RCF 1/8W 220R 5% ATS
R601,R603,R605,R607,R609,R611	4701-331J-C	RCF 1/8W 330R 5% ATS
R613,R614,R617,R618	4701-333J-C	RCF 1/8W 33K 5% ATS
R627	4701-393J-C	RCF 1/8W 39K 5% ATS
R645,R646,R653,R654,R665,R666, R675,R676,R683,R684,R695,R696	4701-471J-C	RCF 1/8W 470R 5% ATS
R6102-R6105,R642,R647,R650,R655,R662, R667,R672,R677,R680,R685,R692,R697	4701-563J-C	RCF 1/8W 56K 5% ATS
R630,R631	4701-682J-C	RCF 1/8W 6.8K 5% ATS
R644,R652,R674,R682,R694	4701-752J-C	RCF 1/8W 7.5K 5% ATS



<b>Reference No.</b>	<b>Part No.</b>	<b>Description</b>
R701,R713,R715,R723,R740 R702,R710,R724,R728,R743 R6016,R6109 R704,R709,R717,R722,R742 R703,R712,R718,R725,R744 R706,R707,R719,R720,R745 R6017,R6108	4720-000J-J 4720-101J-J 4720-102J-J 4720-104J-J 4720-121J-J 4720-202J-J 4720-223J-J	RMG 1/10W 0R 5% 0805 RMG 1/10W 100R 5% 0805 RMG 1/10W 1K 5% 0805 RMG 1/10W 100K 5% 0805 RMG 1/10W 120R 5% 0805 RMG 1/10W 2K 5% 0805 RMG 1/10W 22K 5% 0805
<b>DIODE</b>		
D601	4804-1480-2	DIODE 1N4148 AT
D605	4804-1480-C	DIODE 1N4148 ATS
D603	4837-5B61-2	DZ 1/2W 5.45-5.73 ROHM
D602,D604	4837-7B51-2	DZ 1/2W 7.07~7.45V ROHM
<b>TRANSISTOR</b>		
Q602,Q608,Q613,Q616,Q621 Q601 Q605,Q606 Q607 Q603,Q604,Q609,Q611,Q614,Q615, Q617,Q619,Q622,Q701-Q704,Q706	485A-114E-5 485C-114E-5 4860-0050-5 4860-0060-5 4860-0770-5	TR DTA114ESA ROHM TR DTC114ES TR SS8050 C/D SAMSUNG RL TR SS8550 C/D SAMSUNG RL TR 2SC2878 (A,B) RL
<b>WIRE</b>		
J601A	7712-1480-2004	WIRE CON ASSY 12P P=2.5
<b>PRIMARY ASSY</b>		
<b>PC BOARD</b>		
(AH/TITANIUM AH)	PCB-N0A40C-PRI	PCB ASSY PRIMARY N0A40C
(CE/TITANIUM CE)	PCB-N0A41C-PRI	PCB ASSY PRI N0A41C
<b>PCB</b>		
5000 (AH/TITANIUM AH)	1725-572C-0101	PCB SPK PHO SEC PRI PSU
5001 (CE/TITANIUM CE)	1725-572C-0101	PCB SPK PHO SEC PRI PSU
<b>PCB ASSY PSU N0A40C</b>		
(AH/TITANIUM AH)	PCB-N0A40C-PSU	PCB ASSY PSU N0A40C
(CE/TITANIUM CE)	PCB-N0A41C-PSU	PCB ASSY PSU N0A41C
<b>PCB</b>		
2000 (AH/TITANIUM AH)	1725-572C-0101	PCB SPK PHO SEC PRI PSU
2001 (CE/TITANIUM CE)	1725-572C-0101	PCB SPK PHO SEC PRI PSU

<b>Reference No.</b>	<b>Part No.</b>	<b>Description</b>
<b>CAPACITOR</b>		
C277	150F-103K-5-II	CC 50V 0.01 $\mu$ F 10% RL 5x5
C276	150F-223K-2-FD	CC 50V 0.022 $\mu$ F 10% AT
C275	157E-227M-5-PU	CE 25V 220 $\mu$ F 20% RL
C278 $\triangle$	8910-0091-0	CC 400V 0.01 $\mu$ F +-20% RL
<b>TRANSFORMER</b>		
T260 $\triangle$	1806-2311-0	EI-35 TRANSFORMER 12V/AC
<b>WAFER</b>		
J203B	2102-051S-004	5P ST.WAFER
J201B	2102-071S-004	WF T8 DE 7PIN COULOMB
<b>JACK</b>		
M268,M269	2113-1179-0	PHONE JACK D3.5 BK
<b>IC</b>		
U260	3130-2520-2	IC 7812H 12V REG, T0220F
<b>RELAY</b>		
M273 $\triangle$	4500-0890-0	RELAY 12VDC,250VAC,10A
<b>RESISTOR</b>		
R268	4701-103J-C	RCF 1/8W 10K 5% ATS
R270,R271	4707-220J-2	RCF 1/2W 22R 5% AT
R269	4707-8R2J-2	RCF 1/2W 8.2R 5% AT
R267 (AH/TITANIUM AH) $\triangle$	4717-335J-2-S	RMF 1/2W 3.3M 5% AT UL
<b>DIODE</b>		
D261,D262,D263,D264	4804-0040-1	DIODE IN4004 AL
D265	4804-1480-C	DIODE 1N4148 ATS
<b>TRANSISTOR</b>		
Q260	485C-123J-5	TR DTC123JSA ROHM
<b>FUSE</b>		
M271 (CE/TITANIUM CE) $\triangle$	5120-0024-0	3.15A TIME-LAG 5X20
M272 (AH/TITANIUM AH) $\triangle$	5120-0052-0	FUSE T1.6A 250V 5X20MM
M270 (AH/TITANIUM AH) $\triangle$	5120-0200-0	FUSE T5A/125V 5X20MM
<b>MISCELLANEOUS</b>		
P265,P266	4131-9321-0	TERMINAL WRAP
P267,P268 (AH/TITANIUM AH) $\triangle$	4131-9321-0	TERMINAL WRAP
M270,M272 (AH/TITANIUM AH) $\triangle$	4132-1011-0	FUSE HOLDER
M271 (CE/TITANIUM CE) $\triangle$	4132-1011-0	FUSE HOLDER
P269 (AH/TITANIUM AH) $\triangle$	4132-1061-0	SOLDER TAG

<b>Reference No.</b>	<b>Part No.</b>	<b>Description</b>
<b>SECONDARY ASSY</b>		
<b>PC BOARD</b>	PCB-N0A40C-SEC	PCB ASSY SECONDARY
<b>PCB</b> 2000	1725-572C-0101	PCB SPK PHO SEC PRI PSU
<b>CAPACITOR</b> C260,C262-C264 C281,C282	150F-104K-2-FC 153I-104J-5-NMN	CC 50V 0.1 $\mu$ F 10% AT CM 63V 0.1 $\mu$ F RL (7.5X7)
<b>WAFER</b> J206A J202B	2101-9400-0 2102-041S-004	JM2422-3M WAFER 4P ST.WAFER
<b>RESISTOR</b> R260 R261-R263	4717-2R2J-2 4718-R22J-2	RMF 1/2W 2.2R 5% AT RMF 1W 0.22R 5% AT
<b>WIRE</b> J704B	7703-1360-2004	CONN.ASSY 3P P205 L=360
<b>SPEAKER ASSY</b>		
<b>PC BOARD</b> (AH/TITANIUM AH) (CE/TITANIUM CE)	PCB-N0A40C-SPK PCB-N0A41C-SPK	PCB ASSY SPEAKER N0A40C PCB ASSY SPK N0A41C
<b>PCB</b> 5000	1725-572C-0101	PCB SPK PHO SEC PRI PSU
<b>CAPACITOR</b> C265-C270	153F-102J-5-IM	CM 50V 1000PF 5% RL 5x7
<b>WAFER</b> P262 P260,P261	2101-9090-0 2101-9100-0	JM2422-2M WAFER JM2422-4M WAFER
<b>TERMINAL</b> M260 (CE/TITANIUM CE) M261 (CE/TITANIUM CE) M260 (AH/TITANIUM AH) M261 (AH/TITANIUM AH)	2113-1655-0 2113-1656-0 2113-1663-1 2113-1664-1	4P SPEAKER TERMINAL R/B 6P SPEAKER TERMINAL R/B 4P SPEAKER TERMINAL R/B 6P SPEAKER TERMINAL R/B



<b>Reference No.</b>	<b>Part No.</b>	<b>Description</b>
<b>S-VIDEO ASSY</b>		
<b>PC BOARD</b>	PCB-N0A40C-SVD	PCB ASSY S-VIDEO N0A40C
<b>PCB</b>		
4000	1725-571C-0000	PCB AVD/MUTI/TUN/VD/SVD
<b>CAPACITOR</b>		
C528	150F-104K-2-FC	CC 50V 0.1 $\mu$ F 10% AT
C525-C527	150F-223K-2-FD	CC 50V 0.022 $\mu$ F 10% AT
C501-C506	157C-476M-5-GM	CE 10V 47 $\mu$ F 20% RL 4X7
C507,C508,C510	157C-477M-5-OU	CE 10V 470 $\mu$ F 20% RL 8X11
C513	157D-106M-5-GM	CE 16V 10 $\mu$ F 20% RL 4x7
C522,C523	157D-107M-5-IU	CE 16V 100 $\mu$ F 20% RL 5x11
C521	157D-227M-5-KW	CE 16V 220 $\mu$ F 20% RL 6x12
C515,C516	157D-476M-5-IM	CE 16V 47 $\mu$ F 20% RL 5X7
C509,C514	157F-225M-5-GM	CE 50V 2.2 $\mu$ F 20% RL 4x7
<b>SOCKET</b>		
J715B,J716B	2101-1801-0	SOCKET (PCB/PCB) 10P
<b>CONNECTOR</b>		
M501,M502,M503,M504, M505	2113-1183-0	1P DIN CONNECTOR HDC-050
<b>IC</b>		
U501	3130-3840-0	IC 4052 QUAD ANALOG SW
<b>RESISTOR</b>		
R512,R513,R525-R527,R538,-R542, R549,R588	4701-102J-C	RCF 1/8W 1K 5% ATS
R550,R551,R552	4701-103J-C	RCF 1/8W 10K 5% ATS
R511,R531	4701-104J-C	RCF 1/8W 100K 5% ATS
R529	4701-122J-C	RCF 1/8W 1.2K 5% ATS
R517,R536	4701-151J-C	RCF 1/8W 150R 5% ATS
R532-R535,R543-R546	4701-203J-C	RCF 1/8W 20K 5% ATS
R516	4701-221J-C	RCF 1/8W 220R 5% ATS
R522	4701-222J-C	RCF 1/8W 2.2K 5% ATS
R523	4701-333J-C	RCF 1/8W 33K 5% ATS
R519,R520,R537,R547,R548	4701-471J-C	RCF 1/8W 470R 5% ATS
R560,R561	4701-512J-C	RCF 1/8W 5.1K 5% ATS
R514,R518	4701-561J-C	RCF 1/8W 560R 5% ATS
R524	4701-562J-C	RCF 1/8W 5.6K 5% ATS
R515	4701-563J-C	RCF 1/8W 56K 5% ATS
R521	4701-680J-C	RCF 1/8W 68R 5% ATS
R501-R506	4701-820J-C	RCF 1/8W 82R 5% ATS
R530	4701-822J-C	RCF 1/8W 8.2K 5% ATS
R528	4715-151A-2	RMF 1/4W 150R 1% AT

<b>Reference No.</b>	<b>Part No.</b>	<b>Description</b>
<b>DIODE</b>		
D501-D507	4804-1480-C	DIODE 1N4148 ATS
Z503	4837-4C20-2	DZ 1/2W 5.0-5.2V AT
Z501,Z502	4837-7C51-2	DZ 1/2W 7.29~7.67V ROHM
<b>TRANSISTOR</b>		
Q518-Q525	485A-933S-5	TR 2SA933S HFE 120-560
Q512,Q513,Q516,Q517,Q526	485C-114E-5	TR DTC114ES
Q501,Q507	485C-123J-5	TR DTC123JSA ROHM
Q509	485C-144E-5	TR DTC144ES ROHM
Q504-Q506,Q508,Q510,Q511,Q514,Q515	4860-0770-5	TR 2SC2878 (A,B) RL
Q502,Q503	4860-1590-5	TR 2SC1740S
<b>SWITCH</b>		
SW501	5200-3171-0-01	DPDT SLIDE
<b>SWITCH ASSY</b>		
<b>PC BOARD</b>	PCB-N0A40C-SW	PCB ASSY SWITCH N0A40C
<b>PCB</b>		
2000	1725-569B-0000	PCB KEY/SWITCH/VOL/LED
<b>CAPACITOR</b>		
C761 	8910-0091-0	CC 400V 0.01UF +-20% RL
<b>SWITCH</b>		
M757 	5200-4839-0	POWER SWITCH TV5
<b>TUNER ASSY</b>		
<b>PC BOARD</b>		
(AH/TITANIUM AH)	PCB-N0A40C-TUN	PCB ASSY TUNER N0A40C
(CE/TITANIUM CE)	PCB-N0A41C-TUN	PCB ASSY TUNER N0A41C
<b>PCB</b>		
9000 (AH/TITANIUM AH)	1725-571C-0000	PCB AVD/MUTI/TUN/VD/SVD
9001 (CE/TITANIUM CE)	1725-571C-0000	PCB AVD/MUTI/TUN/VD/SVD
<b>CAPACITOR</b>		
C381-C386,C914,C915,C945,C982	150F-101K-2-FC	CC 50V 100pF 10% AT 3.5x
C912,C913	150F-102K-2-FC	CC 50V 1000pF 10% AT 3.5
C992	150F-103K-5-II	CC 50V 0.01μF 10% RL 5x5
C911	150F-200J-2-FC	CC 50V 20pF 5% AT 3.5x2
C902,C903,C930,C932,C941,C949,C950, C968,C974,C976,C978,C981,C987	150F-223K-2-FD	CC 50V 0.022μF 10% AT

<b>Reference No.</b>	<b>Part No.</b>	<b>Description</b>
C901 (CE/TITANIUM CE)	150F-223K-2-FD	CC 50V 0.022 $\mu$ F 10% AT
C916	150F-331K-2-FC	CC 50V 330pF 10% AT 3.5x
C985	150F-561K-2-FC	CC 50V 560pF 10% AT 3.5x
C991	153F-102J-5-IM	CM 50V 1000PF 5% RL 5x7
C961,C962 (CE/TITANIUM CE)	153F-152J-5-JM	CM 50V 1500PF 5% RL
C970	153F-223J-5-LQ	CM 50V 0.022 $\mu$ F 5% RL
C953,C954,C965	153F-272J-5-JM	CM 50V 2700PF 5% RL
C961,C962 (AH/TITANIUM AH)	153F-272J-5-JM	CM 50V 2700PF 5% RL
C926	153F-333J-5-NLM	CM 50V 0.033 $\mu$ F 5% RL 7.5
C973	153F-473J-5-NLM	CM 50V 0.047 $\mu$ F 5% RL 7.5
C931,C986,C990	157B-107M-5-KM	CE 6.3V 100 $\mu$ F 20% RL 6x7
C904,C928,C975	157D-106M-5-GM	CE 16V 10 $\mu$ F 20% RL 4x7
C906,C942	157D-107M-5-IU	CE 16V 100 $\mu$ F 20% RL 5x11
C959,C960,C963,C964,C979	157D-226M-5-GM	CE 16V 22 $\mu$ F 20% RL 4X7
C967	157D-474M-5-II	CE 16V 0.47 $\mu$ F 20% RL 5x5
C969	157D-476M-5-IM	CE 16V 47 $\mu$ F 20% RL 5X7
C946,C948	157F-105M-5-GM	CE 50V 1 $\mu$ F 20% RL 4x7
C929	157F-224M-5-GM	CE 50V 0.22 $\mu$ F 20% RL 4x7
C927,C943,C951,C977	157F-225M-5-GM	CE 50V 2.2 $\mu$ F 20% RL 4x7
C947	157F-474M-5-GM	CE 50V 0.47 $\mu$ F 20% RL 4x7
C944	157F-475M-5-GM	CE 50V 4.7 $\mu$ F 20% RL 4x7
C971	15CH-080D-5-GG	CTC 0/60 8pF 0.5pF RL
C924,C925	15CH-200J-5-GG	CTC 0/60 20pF 5% RL 4x4
C988,C989	15CH-300J-5-IG	CTC 0/60 30pF 5% RL 5x4
<b>TUNER</b>		
M901 (CE/TITANIUM CE)	1300-0800-0	TUNER ENV17103G1 CE VER
M901 (AH/TITANIUM AH)	1300-0810-0	TUNER ENV16102G1 UL VER
<b>COIL</b>		
L905,L906,L985	1801-101K-M	COIL 100 $\mu$ H 10%
L901	1801-220K-M	COIL 22 $\mu$ H 10% AL BL7
<b>SOCKET/TERMINAL</b>		
J704B	2101-1601-0	SOCKET (PCB/PCB) 16P
J703B	2101-1801-0	SOCKET (PCB/PCB) 10P
1003 (AH/TITANIUM AH)	2107-0641-0	ANT-TERMINAL F-TYPE
1003 (CE/TITANIUM CE)	2107-0681-0	ANT-TERMINAL (DIN-TYPE)
<b>JACK/WAFER</b>		
P901	2113-1160-0	WAFER 2P ST. P=2.5 NH
1002	2113-1677-0	6P RCA JACK R/W NI
<b>CRYSTAL</b>		
M905	2300-0440-0	CRYSTAL 7.2MHZ 20PPM
M985	2300-1220-0	CRYSTAL 4.332MHZ

<b>Reference No.</b>	<b>Part No.</b>	<b>Description</b>
<b>CERAMIC FILTERS</b>		
M902,M904	2701-0010-1	CF10.7 +-30
M903 (CE/TITANIUM CE)	2701-0010-1	CF10.7 +-30
M911	2701-0680-0	CF 450 +-1
<b>IC</b>		
U901	3130-8180-0	IC LA1837 AM/FM IF
U903	3131-3760-0	IC LC7218 PLL FREQ
U902	3131-9040-0	IC LC72723M RDS
<b>RESISTOR</b>		
J991 (AH/TITANIUM AH)	4701-000J-2	RCF 1/8W 0R 5% AT
R911	4701-101J-C	RCF 1/8W 100R 5% ATS
R916,R919-R924,R951,R968,R985-R987	4701-102J-C	RCF 1/8W 1K 5% ATS
R903 (AH/TITANIUM AH)	4701-102J-C	RCF 1/8W 1K 5% ATS
R906,R915,R927,R933,R947,R948, R954,R972	4701-103J-C	RCF 1/8W 10K 5% ATS
R340,R342,R382,R384,R386,R388, R944,R963,R964,R974	4701-104J-C	RCF 1/8W 100K 5% ATS
R903 (CE/TITANIUM CE)	4701-123J-C	RCF 1/8W 12K 5% ATS
R973	4701-183J-C	RCF 1/8W 18K 5% ATS
R902,R931,R955	4701-220J-C	RCF 1/8W 22R 5% ATS
R928	4701-221J-C	RCF 1/8W 220R 5% ATS
R961,R962	4701-222J-C	RCF 1/8W 2.2K 5% ATS
R952,R953	4701-223J-C	RCF 1/8W 22K 5% ATS
R957,R958 (CE/TITANIUM CE)	4701-272J-C	RCF 1/8W 2.7K 5% ATS
R913	4701-330J-C	RCF 1/8W 33R 5% ATS
R341,R381,R383,R385,R387,R389, R909,R910	4701-331J-C	RCF 1/8W 330R 5% ATS
R904 (CE/TITANIUM CE)	4701-331J-C	RCF 1/8W 330R 5% ATS
R929,R946,R949	4701-332J-C	RCF 1/8W 3.3K 5% ATS
R901,R957,R958 (AH/TITANIUM AH)	4701-332J-C	RCF 1/8W 3.3K 5% ATS
R907 (CE/TITANIUM CE)	4701-332J-C	RCF 1/8W 3.3K 5% ATS
R975 (AH/TITANIUM AH)	4701-333J-C	RCF 1/8W 33K 5% ATS
R901 (CE/TITANIUM CE)	4701-333J-C	RCF 1/8W 33K 5% ATS
R959,R960 (CE/TITANIUM CE)	4701-334J-C	RCF 1/8W 330K 5% ATS
R945	4701-392J-C	RCF 1/8W 3.9K 5% ATS
R908 (CE/TITANIUM CE)	4701-471J-C	RCF 1/8W 470R 5% ATS
R918,R942	4701-472J-C	RCF 1/8W 4.7K 5% ATS
R975 (CE/TITANIUM CE)	4701-563J-C	RCF 1/8W 56K 5% ATS
R905 (CE/TITANIUM CE)	4701-681J-C	RCF 1/8W 680R 5% ATS
R959,R960 (AH/TITANIUM AH)	4701-683J-C	RCF 1/8W 68K 5% ATS
R950	4701-684J-C	RCF 1/8W 680K 5% ATS
R925,R926	4701-820J-C	RCF 1/8W 82R 5% ATS
R943	4701-822J-C	RCF 1/8W 8.2K 5% ATS

<b>Reference No.</b>	<b>Part No.</b>	<b>Description</b>
<b>SVR</b> R956 R941	4756-1036-3-06 4756-2236-3-06	SVR 10K H3 7X7.6 RH0615C SVR 22K H3 7X7.6 RH0615C
<b>DIODE</b> D901 D902	4837-4C20-2 4837-7C20-2	DZ 1/2W 5.0-5.2V AT DZ 1/2W 9.1-9.5V AT
<b>TRANSISTOR</b> Q902 Q903,Q945 Q901 (CE/TITANIUM CE) Q922,Q923,Q942 Q943,Q944	4851-9230-5 485A-114E-5 485C-945P-5 4860-1590-5 4860-8120-G	TR 2SC1923-0 HFE 70-140 TR DTA114ESA ROHM TR 2SC945P HFE 200-400 TR 2SC1740S TR 2SD1468S TPS ROHM
<b>MISCELLANEOUS</b>  GND (AH/TITANIUM AH) L971 L903,L904 L941 L942 L972	4131-7701-0 4131-7701-0 5600-3280-G 5600-3386-S 5600-3396-S 5600-3406-S 5600-3416-S	ANTENNA WASHER ANTENNA WASHER COIL MW RF BLOCK COIL MPX LPF NMC-4085 COIL FM DET-1 10.7MHZ COIL FM DET-2 10.7MHZ COIL AM IFT NMIF-4062
<b>VIDEO ASSY</b> <b>PC BOARD</b>	PCB-N0A40C-VD	PCB ASSY VIDEO N0A40C
<b>PCB</b> 4000	1725-571C-0000	PCB AVD/MUTI/TUN/VD/SVD
<b>CAPACITOR</b> C40-C405 C412 C406,C407,C409,C410 C408,C411	157D-107M-5-KW 157D-108M-5-S5 157D-476M-5-IM 157D-477M-5-SY	CE 16V 100 $\mu$ F 20% RL 6x12 CE 16V 1000 $\mu$ F 20% RL CE 16V 47 $\mu$ F 20% RL 5X7 CE 16V 470 $\mu$ F 20% RL
<b>DIODE</b> D401,D402 Z401,Z402	4804-1480-C 4837-7C51-2	DIODE 1N4148 ATS DZ 1/2W 7.29~7.67V ROHM
<b>SOCKET</b> J714B	2101-1801-0	SOCKET (PCB/PCB) 10P
<b>JACK</b> M403 M402	2113-1316-0 2113-1775-0	1P RCA JACK YL NI JACK RCA 2P TL NICKEL-

<b>Reference No.</b>	<b>Part No.</b>	<b>Description</b>
M401	2113-1776-0	JACK RCA 4P YL NICKEL-
<b>IC</b>		
U401	3131-4100-0	IC MC14051BCP MOTOROLA
<b>RESISTOR</b>		
R402,R408,R419,R421	4701-102J-C	RCF 1/8W 1K 5% ATS
R405,R406,R407	4701-103J-C	RCF 1/8W 10K 5% ATS
R410,R414,R417	4701-151J-C	RCF 1/8W 150R 5% ATS
R409,R411-R416	4701-203J-C	RCF 1/8W 20K 5% ATS
R403,R404,R428,R429	4701-222J-C	RCF 1/8W 2.2K 5% ATS
R424-R427	4701-820J-C	RCF 1/8W 82R 5% ATS
<b>TRANSISTOR</b>		
Q404,Q405,Q406	485A-933S-5	TR 2SA933S HFE 120-560
Q401-Q403,Q408,Q409,Q411,Q412	485C-114E-5	TR DTC114ES
Q407,Q410	4860-0770-5	TR 2SC2878 (A,B) RL
<b>VIDEO5 ASSY</b>		
<b>PC BOARD</b>	PCB-N0A40C-VD5	PCB ASSY VIDEO 5 N0A40C
<b>PCB</b>		
6000	1725-572C-0101	PCB SPK PHO SEC PRI PSU
<b>CAPACITOR</b>		
C501,C502	150F-101J-5-IF	CC 50V 100pF 5% RL 5x3.5
C503,C504	150F-102K-2-FC	CC 50V 1000pF 10% AT 3.5
C520,C521	150F-223K-2-FD	CC 50V 0.022 $\mu$ F 10% AT
C505	157F-225K-5-GM	CE 50V 2.2 $\mu$ F 10% RL 4X7
<b>JACK</b>		
M265	2113-1011-0	PHONE JACK
M264	2113-1290-0	1P RCA YL GOLD PLATED GN
M266	2113-1291-0	1P RCA WH GOLD PLATED GN
M267	2113-1292-0	1P RCA RD GOLD PLATED GN
<b>RESISTOR</b>		
R503,R504	4701-105J-C	RCF 1/8W 1M 5% ATS
R501,R502	4701-331J-C	RCF 1/8W 330R 5% ATS
R505	4701-820J-C	RCF 1/8W 82R 5% ATS
<b>WIRE</b>		
J401A	7711-1480-2004	WIRE CON ASSY 11P P=2.5
<b>MISCELLANEOUS</b>		
GND	4132-1061-0	SOLDER TAG

<b>Reference No.</b>	<b>Part No.</b>	<b>Description</b>
<b>VOLUME ASSY</b>		
<b>PC BOARD</b>	PCB-N0A40C-VOL	PCB ASSY VOLUME N0A40C
<b>PCB</b>		
2000	1725-569B-0000	PCB KEY/SWITCH/VOL/LED
<b>WAFER</b>		
J207B	2102-031R-004	WAFER 3P P2.5 RIGHT
<b>MISCELLANEOUS</b>		
M301	4750-6000-0	ROTARY ENCODER

- NOTE:**
- The components identified by  $\triangle$  mark are critical for risk of fire and electrical shock. Replace only with part number specified.
  - <AH > : USA, Canadian model only.
  - <C > : European model only.
  - Capacitors : CP-Polystyrene, CM-Mylar, CE-Electrolytic, CC-Ceramic, CTC-NPO.
  - Resistors : RMF-Metal Film, RCF-Carbon Film, RWR-Wirewound Metal Oxide.





# EXPLODED VIEW PARTS LIST

<b>ITEM</b>	<b>Part No.</b>	<b>Description</b>	<b>Qty</b>
0101	1403-5164-1	CHASSIS T742 NICKEL	1
0102 (AH/TITANIUM AH)	1403-5178-2	REAR PANEL T742AH NICKEL	1
0102 (CE/TITANIUM CE)	1403-5179-2	REAR PANEL T742C NICKEL	1
0103 (AH/CE)	1404-5201-0	TOP COVER T742 NICKEL	1
0103 (TITANIUM AH/TITANIUM CE)	1404-5202-0	TOP COVER T742 NICKEL	1
0104	1404-5301-0	SUBFASCIA T742 NICKEL	1
0105 (AH/CE)	1404-5401-0	FASCIA T742 NICKEL DARK	1
0105 (TITANIUM AH/TITANIUM CE)	1404-5402-0	FASCIA T742 NICKEL	1
0106 (AH/CE)	4154-0301-0	INPUT BEZEL T-760	1
0106 (TITANIUM AH/TITANIUM CE)	4154-0302-0	VIDEO BEZEL TITANIUM	1
0107 (AH/CE)	4135-2671-0	ENDCAP RIGHT T742 NICKEL	1
0107 (TITANIUM AH/TITANIUM CE)	4135-2672-0	ENDCAP RIGHT TITANIUM	1
0108 (AH/CE)	4135-2661-0	ENDCAP LEFT T742 NICKEL	1
0108 (TITANIUM AH/TITANIUM CE)	4135-2662-0	ENDCAP LEFT TITANIUM	1
0109	4134-2181-0	COVER BKT	2
0110	4134-9061-0	BRACKET PHONES	1
0112	4154-0311-0	DUMMY CLAMP	1
0113 (AH/CE)	2444-1601-0	POWER BUTTON GREEN LONG	1
0113 (TITANIUM AH/TITANIUM CE)	2444-1602-0	POWER BUTTON TITANIUM	1
0114	3716-4401-0	WINDOW LENS	1
0116 (AH/CE)	4152-4341-0	INPUT BUTTON LOZENGE	1
0116 (TITANIUM AH/TITANIUM CE)	4152-4342-0	INPUT BUTTON LOZENGE	1
0119 (AH/CE)	2444-1901-0	DUO BUTTON T-760	1
0119 (TITANIUM AH/TITANIUM CE)	2444-1902-0	DUO BUTTON TITANIUM	1
0120 (AH/CE)	2444-1301-1	BUTTON RACKER (NICKEL)	1
0120 (TITANIUM AH/TITANIUM CE)	2444-1302-1	BUTTON RACKER TITANIUM	1
0121 (AH/CE)	4154-0091-0	BEZEL RACKER (NICKEL)	1
0121 (TITANIUM AH/TITANIUM CE)	4154-0092-0	BEZEL RACKER TITANIUM	1
0122 (AH/CE)	2444-2101-0	INPUT BUTTON	4
0122 (TITANIUM AH/TITANIUM CE)	2444-2102-0	INPUT BUTTON TITANIUM	4
0123 (AH/CE)	4154-0411-0	BEZEL DUO	1
0123 (TITANIUM AH/TITANIUM CE)	4154-0412-0	BEZEL DUO TITANIUM	1
0124 (AH/CE)	2444-6001-0	KNOB VOLUME T-741	1
0124 (TITANIUM AH/TITANIUM CE)	2444-6002-0	KNOB VOLUME TITANIUM	1
0126	4152-4631-0	RUBBER FOOT (522) 14MM	4
0127	4152-4641-1	CUSHION FOOT W/RUBBER WA	4
0128 (AH/CE)	4152-4331-0	POWER BUTTON BEZEL	1
0128 (TITANIUM AH/TITANIUM CE)	4152-4332-0	POWER BUTTON BEZEL	1
0129 (AH/CE)	4154-0331-0	VIDEO COVER T-760	1
0129 (TITANIUM AH/TITANIUM CE)	4154-0332-0	VIDEO COVER TITANIUM 742	1
0130 (AH/CE)	4152-1701-0	LED BEZEL (117)	0.5
0130 (TITANIUM AH/TITANIUM CE)	4152-1702-0	LED BEZEL TITANIUM	0.5
0131	3714-5706-0	LED LENS (412) CLEAR SAN	1
0133 	4152-3851-0	SQ. STRAIN RELIEF	1

ITEM	Part No.	Description	Qty
0134 (AH/TITANIUM AH) $\triangle$	7009-3100-2	AC CORD 18AWGX2	1
0134 (CE/TITANIUM CE) $\triangle$	7009-3110-0	AC CORD (SEMKO)	1
0136	5400-9052-0	HEAT SINK T-741	1
0137	4134-0121-0	BRACKET, HTSK MOUNT	2
0138,0301,0309	4152-0451-0	L-BRACKET	4
0139	2600-4008-0973	FLAT WASHER M4X0.8X9.7	4
0140	2607-4010-0703	SPRING WASHER M4X1X7 BZ	4
0141	2904-4010-3000	SCREW M4X10 (BLK)	4
0142,0149,0151,0152,0153,0184,0320	2954-3008-3000	T3X8MM SELF TAPPING	44
0143	2842-3367-0	METAL WASHER	4
0144 (AH/CE)	2900-4006-3010	M4X0.5PX6MM W/FLAT	6
0144 (TITANIUM AH/TITANIUM CE)	2900-4006-2010	SCM PW M4X6 RECESS WHITE	6
0145 (AH/CE)	2954-3008-3000	T3X8MM SELF TAPPING	2
0145 (TITANIUM AH/TITANIUM CE)	2954-3010-4000	ST SCREW 3X10 BH	2
0146,0163,0313,0315	2904-3008-0000	M3X8MM BINDING HEAD	16
0147,0150,0167,0307,0308	2954-3006-0000	3X6MM B-TITE (YEL.ZN)	8
0148,0156,0157,0158,0159,0160,0161, 0164,0166,0310,0314,0315,0316,0317	2954-3008-0000	TAPPING 3X8MM B-TITE	31
0154	2954-2606-3000	SCREW BH 2.6X6 BLACK	9
0155	2954-2608-3000	SCREW BT 2.6X8 BLACK	14
0162	2904-3006-0000	SCREW M3X6	1
0168	2900-3010-3030	SCREW M3X10 W/S&F	11
0176	3100-3211-0	SILICON SHEET (26X20MM)	10
0178	4152-5831-0	PCB SUPPORT 12MM HIGH	1
0187	2640-4030-0703	M4 NUT (BLK)	4
0187	4135-1641-0	BRACKET HEATSINK	2
0188	4153-9291-0	FOAM 60X13X5 W/TAPE	4
0189 (AH/CE)	2444-1201-0	BUTTON TRIO (NICKEL)	1
0189 (TITANIUM AH/TITANIUM CE)	2444-1202-0	BUTTON TR10 TITANIUM	1
0193 (AH/CE)	4154-0031-0	BEZEL TRIO (NICKEL)	1
0193 (TITANIUM AH/TITANIUM CE)	4154-0032-0	BEZEL TR10 TITANIUM	1
0204	2601-2608-0601	FIBRE WASHER M2.6 0.8T	3
0205	4152-3291-1	FOAM 6X4X1.5T MM	1
0208	4152-1161-0	FOAM RUBBER 10X10X10 BK	2
0210	2954-2006-0000	TAPPING SCREW 2X6	6
0220	2600-4508-0980	WASHER M4.5 0.8T OD=9.8	1
0302	4133-2090-0	2204-3 MTG BKT	2
0303	4135-2751-1	MOUNTING BRACKET AMP2	1
0304	4134-2461-0	HEAT SINK MOUNTING BKT	2
0319	4135-1651-0	BRACKET PCB-AMP2	1
0311	4135-1791-0	BRACKET VOLUME T741	1
0321	2640-9020-1203	M9 NUT (BLK)	1
0322	2600-9005-1403	M9 WASHER BK ZINC	1
T002 $\triangle$	1806-2441-1	TRANSFORMER FOR T742	1

- NOTE:**
- The components identified by  $\triangle$  mark are critical for risk of fire and electrical shock. Replace only with part number specified.
  - <AH > : USA, Canadian model only.
  - <C > : European model only.

# PACKING DIAGRAM

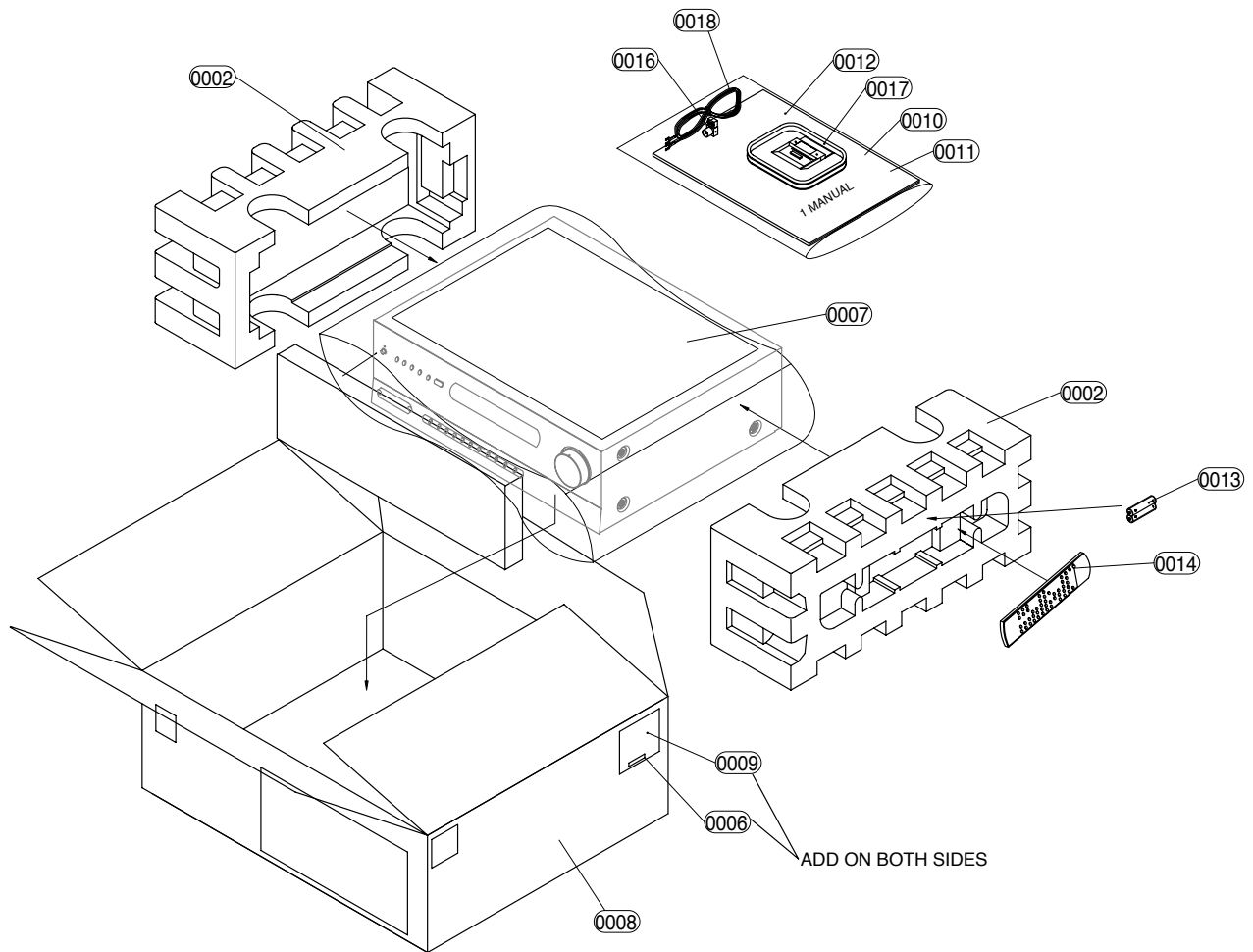

ITEM	PART NO.	DESCRIPTION	Q'TY
0002	1490-3854-0	POLYFOAM ENDCAP T741	2
0006	3000-9337-0	LABEL SERIAL NUMBER T742	1
0007	1450-2520-0	WHITE PAPER A3-SIZE	1
0008	1436-0701-0-3	CARTON BOX T742 NICKEL	1
0009 (AH)	3000-9349-1	LABEL VERSION AH GREY	2
0009 (CE)	3000-9350-1	LABEL VERSION C GREY	2
0009 (TITANIUM AH)	3000-9336-1	LABEL VERSION AH TITANIUM	2
0009 (TITANIUM CE)	3000-9347-1	LABEL VERSION C TITANIUM	2
0010 (AH/TITANIUM AH)	3030-1225-1	WARRANTY CARD AH NICKEL	1
0011 (AH/TITANIUM AH)	3030-1057-2	SAFETY INSTRUCTION SHEET	1
0012	4301-7023-1	INSTRUCTION MANUAL T742	1
0013	4060-0530-0	GREENCELL 3A SIZE GP24G2	2
0014	8912-0026-0	REMOTE CONTROL HANDSET	1
0016	2107-0661-1	300-OHM T ANTENNA	1
0017	2113-1155-0	AM LOOP ANTENNA	1
0018	2103-6101-0	RF CONNECTOR PLUG	1

Proprietary information for servicing purposes only. The information herein may not be used commercially without the prior written agreement of NAD Electronics International, Toronto, Canada.

# SERVICE MANUAL

# T 742

SURROUND  
SOUND RECEIVER

© NAD 2002

NAD ELECTRONICS INTERNATIONAL  
TORONTO