

T747
AV Surround Sound Receiver

SERVICE MANUAL

T747
AV Surround Sound Receiver



SECTION 1

SUMMARY

CONTENTS

PRODUCT SAFETY SERVICING GUIDELINES	1-3
SERVICING PRECAUTIONS	1-4
* General Servicing Precautions	
* Insulation checking procedure	
* Electrostatically Sensitive Devices	
SPECIFICATIONS	1-5
DISASSEMBLY	1-6
PRINCIPAL PART LOCATION	1-7
EXPLODED VIEW	1-8

PRODUCT SAFETY SERVICING GUIDELINES

CAUTION : DO NOT ATTEMPT TO MODIFY THIS PRODUCT IN ANY WAY. NEVER PERFORM CUSTOMIZED INSTALLATIONS WITHOUT MANUFACTURER'S APPROVAL. UNAUTHORIZED MODIFICATIONS WILL NOT ONLY VOID THE WARRANTY, BUT MAY LEAD TO YOUR BEING LIABLE FOR ANY RESULTING PROPERTY DAMAGE OR USER INJURY.

SERVICE WORK SHOULD BE PERFORMED ONLY AFTER YOU ARE THOROUGHLY FAMILIAR WITH ALL OF THE FOLLOWING SAFETY CHECKS AND SERVICING GUIDELINES. TO DO OTHERWISE, INCREASES THE RISK OF POTENTIAL HAZARDS AND INJURY TO THE USER.

WHILE SERVICING, USE AN ISOLATION TRANSFORMER FOR PROTECTION FROM AC LINE SHOCK.

SAFETY CHECKS

AFTER THE ORIGINAL SERVICE PROBLEM HAS BEEN CORRECTED. A CHECK SHOULD BE MADE OF THE FOLLOWING.

SUBJECT : FIRE & SHOCK HAZARD

1. BE SURE THAT ALL COMPONENTS ARE POSITIONED IN SUCH A WAY AS TO AVOID POSSIBILITY OF ADJACENT COMPONENT SHORTS. THIS IS ESPECIALLY IMPORTANT ON THOSE MODULES WHICH ARE TRANSPORTED TO AND FROM THE REPAIR SHOP.
2. NEVER RELEASE A REPAIR UNLESS ALL PROTECTIVE DEVICES SUCH AS INSULATORS, BARRIERS, COVERS, SHIELDS, STRAIN RELIEFS, POWER SUPPLY CORDS, AND OTHER HARDWARE HAVE BEEN REINSTALLED PER ORIGINAL DESIGN. BE SURE THAT THE SAFETY PURPOSE OF THE POLARIZED LINE PLUG HAS NOT BEEN DEFEATED.
3. SOLDERING MUST BE INSPECTED TO DISCOVER POSSIBLE COLD SOLDER JOINTS, SOLDER SPLASHES OR SHARP SOLDER POINTS. BE CERTAIN TO REMOVE ALL LOOSE FOREIGN PARTICLES.
4. CHECK FOR PHYSICAL EVIDENCE OF DAMAGE OR DETERIORATION TO PARTS AND COMPONENTS. FOR FRAYED LEADS, DAMAGED INSULATION (INCLUDING AC CORD). AND REPLACE IF NECESSARY FOLLOW ORIGINAL LAYOUT, LEAD LENGTH AND DRESS.
5. NO LEAD OR COMPONENT SHOULD TOUCH A RECEIVING TUBE OR A RESISTOR RATED AT 1 WATT OR MORE. LEAD TENSION AROUND PROTRUDING METAL SURFACES MUST BE AVOIDED.
6. ALL CRITICAL COMPONENTS SUCH AS FUSES, FLAMEPROOF RESISTORS, CAPACITORS, ETC. MUST BE REPLACED WITH EXACT FACTORY TYPES, DO NOT USE REPLACEMENT COMPONENTS OTHER THAN THOSE SPECIFIED OR MAKE UNRECOMMENDED CIRCUIT MODIFICATIONS.
7. AFTER RE-ASSEMBLY OF THE SET ALWAYS PERFORM AN AC LEAKAGE TEST ON ALL EXPOSED METALLIC PARTS OF THE CABINET, (THE CHANNEL SELECTOR KNOB, ANTENNA TERMINALS. HANDLE AND SCREWS) TO BE SURE THE SET IS SAFET TO OPERATE WITHOUT DANGER OF ELECTRICAL SHOCK. DO NOT USE A LINE ISOLATION TRANSFORMER DURING THIS TEST USE AN AC VOLTMETER, HAVING 5000 OHMS PER VOLT OR MORE SENSITIVITY, IN THE FOLLOWING MANNER; CONNECT A 1500 OHM 10 WATT RESISTOR, PARALLELED BY A .15 MFD, 150V AC TYPE CAPACITOR BETWEEN A KNOWN GOOD EARTH GROUND (WATER PIPE, CONDUIT, ETC.) AND THE EXPOSED METALLIC PARTS, ONE AT A TIME.
MEASURE THE AC VOLTAGE ACROSS THE COMBINATION OF 1500 OHM RESISTOR AND .15 MFD CAPACITOR.
REVERSE THE AC PLUG AND REPEAT AC VOLTAGE MEASUREMENTS FOR EACH EXPOSED METALLIC PART.

VOLTAGE MEASURE MUST NOT EXCEED 75 VOLTS R.M.S. THIS CORRESPONDS TO 0.5 MILLIAMPER AC ANY VALUE EXCEEDING THIS LIMIT CONSTITUTES A POTENTIAL SHOCK HAZARD AND MUST BE CORRECTED IMMEDIATELY.

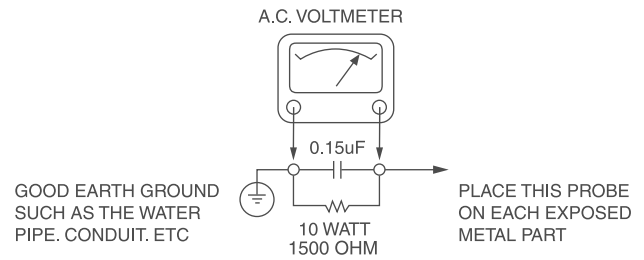

SUBJECT : GRAPHIC SYMBOLS



THE LIGHTNING FLASH WITH ARROWHEAD SYMBOL, WITHIN AN EQUILATERAL TRIANGLE, IS INTENDED TO ALERT THE USER TO THE PRESENCE OF UNINSULATED "DANGEROUS VOLTAGE" WITHIN THE PRODUCT'S ENCLOSURE THAT MAY BE OF SUFFICIENT MAGNITUDE TO CONSTITUTE A RISK OF ELECTRIC SHOCK.



THE EXCLAMATION POINT WITHIN AN EQUILATERAL TRIANGLE IS INTENDED TO ALERT THE USER TO THE PRESENCE OF IMPORTANT OPERATING AND MAINTENANCE (SERVICING) INSTRUCTIONS IN THE LITERATURE ACCOMPANYING THE APPLIANCE.

SUBJECT : TIPS ON PROPER INSTALLATION

1. NEVER INSTALL ANY PRODUCT IN A CLOSED-IN RECESS, CUBBYHOLE OR CLOSELY FITTING SHELF SPACE. OVER OR CLOSE TO HEAT DUCT, OR IN THE PATH OF HEATED AIR FLOW.
2. AVOID CONDITIONS OF HIGH HUMIDITY SUCH AS: OUTDOOR PATIO INSTALLATIONS WHERE DEW IS A FACTOR, NEAR STEAM RADIATORS WHERE STEAM LEAKAGE IS A FACTOR, ETC.
3. AVOID PLACEMENT WHERE DRAPERIES MAY OBSTRUCT REAR VENTING. THE CUSTOMER SHOULD ALSO AVOID THE USE OF DECORATIVE SCARVES OR OTHER COVERINGS WHICH MIGHT OBSTRUCT VENTILATION.
4. WALL AND SHELF MOUNTED INSTALLATIONS USING A COMMERCIAL MOUNTING KIT MUST FOLLOW THE FACTORY APPROVED MOUNTING INSTRUCTIONS A PRODUCT MOUNTED TO A SHELF OR PLATFORM MUST RETAIN ITS ORIGINAL FEET (OR THE EQUIVALENT THICKNESS IN SPACERS) TO PROVIDE ADEQUATE AIR FLOW ACROSS THE BOTTOM, BOLTS OR SCREWS USED FOR FASTENERS MUST NOT TOUCH ANY PARTS OR WIRING. PERFORM LEAKAGE TEST ON CUSTOMIZED INSTALLATIONS.
5. CAUTION CUSTOMERS AGAINST THE MOUNTING OF A PRODUCT ON SLOPING SHELF OR A TILTED POSITION, UNLESS THE PRODUCT IS PROPERLY SECURED.
6. A PRODUCT ON A ROLL-ABOUT CART SHOULD BE STABLE ON ITS MOUNTING TO THE CART. CAUTION THE CUSTOMER ON THE HAZARDS OF TRYING TO ROLL A CART WITH SMALL CASTERS ACROSS THRESHOLDS OR DEEP PILE CARPETS.
7. CAUTION CUSTOMERS AGAINST THE USE OF A CART OR STAND WHICH HAS NOT BEEN LISTED BY UNDERWRITERS LABORATORIES, INC. FOR USE WITH THEIR SPECIFIC MODEL OF TELEVISION RECEIVER OR GENERICALLY APPROVED FOR USE WITH T.V.'S OF THE SAME OR LARGER SCREEN SIZE.
8. CAUTION CUSTOMERS AGAINST THE USE OF EXTENSION CORDS, EXPLAIN THAT A FOREST OF EXTENSIONS SPROUTING FROM A SINGLE OUTLET CAN LEAD TO DISASTROUS CONSEQUENCES TO HOME AND FAMILY.

SERVICING PRECAUTIONS

CAUTION : Before servicing the A/V Receiver covered by this service data and its supplements and addends, read and follow the **SAFETY PRECAUTIONS**. **NOTE :** if unforeseen circumstances create conflict between the following servicing precautions and any of the safety precautions in this publication, always follow the safety precautions.

Remember Safety First:

General Servicing Precautions

1. Always unplug the A/V Receiver AC power cord from the AC power source before:
 - (1) Removing or reinstalling any component, circuit board, module, or any other assembly.
 - (2) Disconnecting or reconnecting any internal electrical plug or other electrical connection.
 - (3) Connecting a test substitute in parallel with an electrolytic capacitor.

Caution : A wrong part substitution or incorrect polarity installation of electrolytic capacitors may result in an explosion hazard.
2. Do not spray chemicals on or near this A/V Receiver or any of its assemblies.
3. Unless specified otherwise in this service data, clean electrical contacts by applying an appropriate contact cleaning solution to the contacts with a pipe cleaner, cottontipped swab, or comparable soft applicator.
Unless specified otherwise in this service data, lubrication of contacts is not required.
4. Do not defeat any plug/socket B+ voltage interlocks with which instruments covered by this service manual might be equipped.
5. Do not apply AC power to this A/V Receiver and/or any of its electrical assemblies unless all solid-state device heat sinks are correctly installed.
6. Always connect test instrument ground lead to the appropriate ground before connecting the test instrument positive lead. Always remove the test instrument ground lead last.

Insulation Checking Procedure

Disconnect the attachment plug from the AC outlet and turn the power on. Connect an insulation resistance meter(500V) to the blades of the attachment plug. The insulation resistance between each blade of the attachment plug and accessible conductive parts (Note 1) should be more than 1M-ohm.

Note 1 : Accessible Conductive Parts including Metal panels, Input terminals, Earphone jacks, etc.

Electrostatically Sensitive (ES) Devices

Some semiconductor (solid state) devices can be damaged easily by static electricity. Such components commonly are called Electrostatically Sensitive (ES) Devices. Examples of typical Es devices are integrated circuits and some field effect transistors and semiconductor chip components.

The following techniques should be used to help reduce the incidence of component damage caused by static electricity.

1. Immediately before handling any semiconductor component or semiconductor-equipped assembly, drain off any electrostatic charge on your body by touching a known earth ground. Alternatively, obtain and wear a commercially available discharging wrist strap device, which should be removed for potential shock reasons prior to applying power to the unit under test.
2. After removing an electrical assembly equipped with ES devices, place the assembly on a conductive surface such as aluminum foil, to prevent electrostatic charge buildup or exposure of the assembly.
3. Use only a grounded-tip soldering iron to solder or unsolder ES devices.
4. Use only an antistatic solder removal device. Some solder removal devices not classified a "anti-static" can generate electrical charges sufficient to damage ES devices.
5. Do not use freonpropelled chemicals. These can generate electrical charge sufficient to damage ES devices.
6. Do not remove a replacement ES device from its protective package until immediately before you are ready to install it. (Most replacement ES devices are packaged with leads electrically shorted together by conductive foam, aluminum foil, or comparable conductive material).
7. Immediately before removing the protective material from the leads of a replacement ES device, touch the protective material to the chassis or circuit assembly into which the device will be installed.

Caution : Be sure no power is applied to the chassis or circuit, and observe all other safety precautions.

8. Minimize bodily motions when handing unpackaged replacement ES devices. (Normally harmless motion such as the brushing together of your clothes fabric or the lifting of your foot from a carpeted floor can generate static electricity sufficient to damage an ES device.)

SPECIFICATIONS

Amplifier Section

Output Power(Front):

F.T.C Ration:

110 watts RMS per channel minimum,
both channels driven into 8 ohms from
20Hz to 20KHz with no more than 0.08%
total harmonic distortion

Surround Output Power (0.08% THD,1KHz,8ohms):

60 + 60 Watt (Front)
60 Watt (Center)
60 + 60 Watt (Surr)
60 + 60 Watt (Back Surr)

Total Harmonic Distortion (Front):

0.08% (at 75 Watts, 1KHz)

Audio input Sensitivity/Impedance :

* Line : 300 mV/47 Kohms

Output Level / Impedance

REC : 300 mV/2.2Kohms

Frequency Response :

* Line : 10Hz – 80KHz, +1/-3dB

Signal-to-Noise Ratio : 1 Watt

* Line : 80 dB (IHF-A)

Tone Control

BASS : +/- dB at 100Hz

TREBLE : +/- dB at 10KHz

Digital audio Section

Sampling Frequency :

32KHz, 44.1KHz, 48KHz, 96KHz

Digital Input Level/Impedance

Coaxial : 0.5 Vp-p/75 ohms

OPTICAL : -15dBm ~ -21dBm

Video Section

Input Sensitivity/Impedance : 1.0Vp-p/75ohms

Output Level/Impedance : 1.0Vp-p/75ohms

*Linemeans Source 1~6, Front, MP

* Improvements may result in specifications and features
changing without notice

* Illustrations may differ slightly from production models.

FM Tuner Section

(Without notes 100.1MHz, 65dBf)

Tuning Range

87.5MHz – 108.0MHz C:50KHz steps

AH:100KHz steps

AM Suppression Ratio : C : 50 dB

AH : 50 dB

Total Harmonic Distortion(1KHz) :

Mono : 0.3%

Stereo : 0.5%

Frequency Response : 20Hz – 15KHz, +1/-1.5dB

Stereo Separation(1KHz) : C : 35dB

AH : 35dB

Signal-to-Noise Ratio:

Mono : 70dB

Stereo : 65dB

AM Tuner Section

Tuning Range:

C:522KHz-1620KHz(9KHz steps)

AH:520KHz-1710KHz(10KHz steps)

Usable Sensitivity : 60dB

Total Harmonic Distortion : 1.5%

Signal-to-Noise Ratio : 40dB

General

Power Requirements :

C : 230V AC, 50Hz

AH : 120V AC, 60Hz

Power Consumption : C : 2.2A

AH : 4.2A

AC Outlets : unswitched x 1, Total 100W max.(1A)

Dimensions(W x H x D) : 435 x 167 x 374

Weight(net) : 13.3Kg

DISASSEMBLY

1> REMOVAL OF TOP COVER

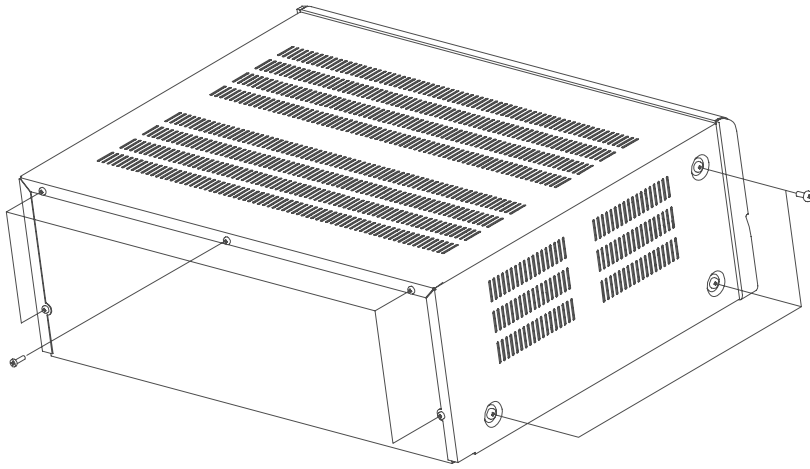

2> REMOVAL OF FRONT PANEL

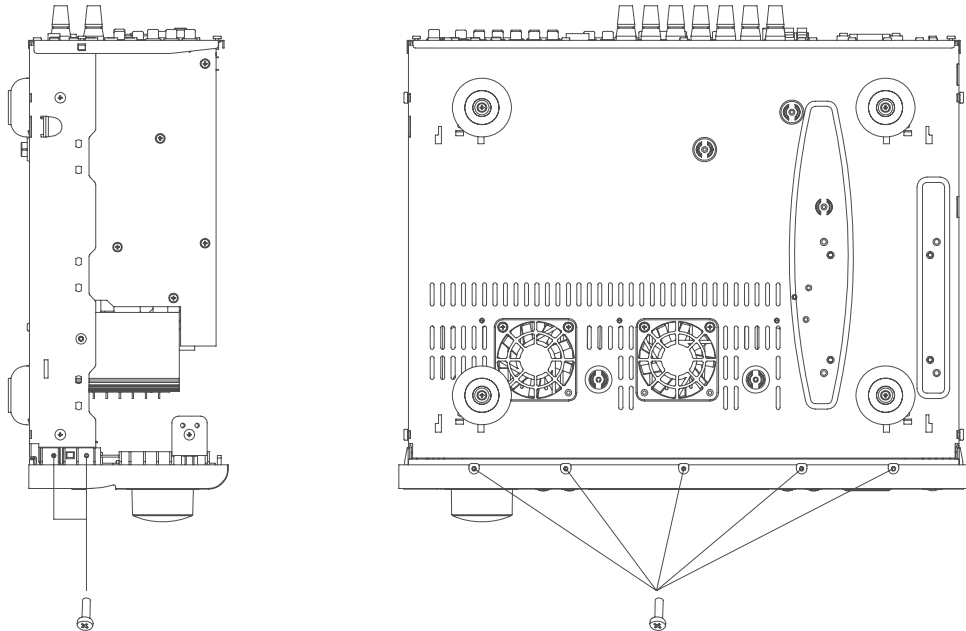

PRINCIPAL PARTS LOCATION

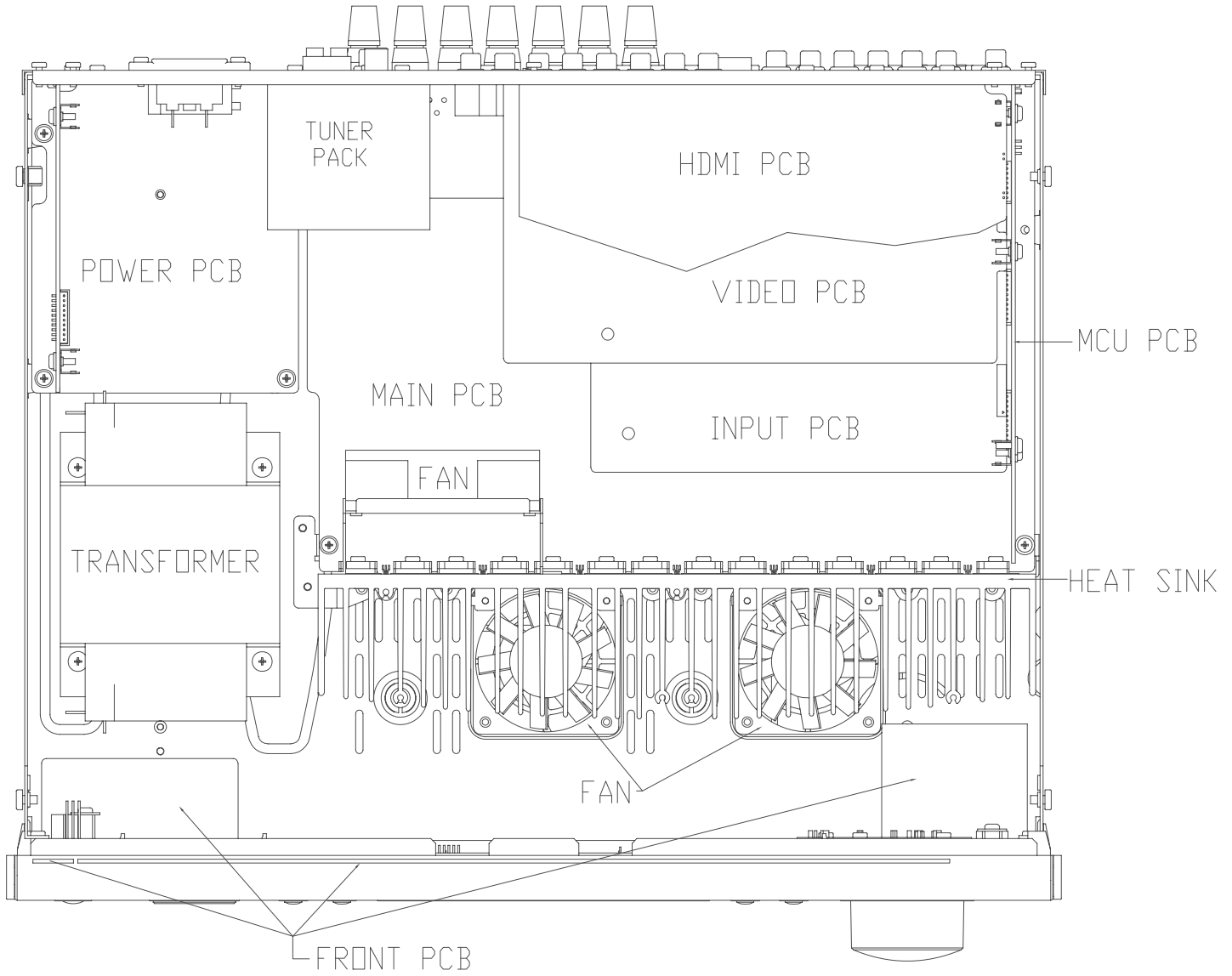

T747AH EXPLODED VIEW PARTS LIST (Graphite)

NO	DESCRIPTION	PARTS NO.	Q,ty	REMARK
1	WINDOW ,FIP	CGUIA434Y	1	
2	VOLUME KNOB ASS'Y	CGK1A145ZA	1	
	KNOB,VOLUME	CBN1A216	1	
	CAP,VOLUME	CGK1A145C64	1	
3	PANEL,AL	CKM1A208YC64	1	
4	PANEL,FRONT	CGW2A475RBYB29	1	
5	COVER,JACK	CGR1A476B29	1	
6	BRACKET	CMD2A563	2	
7	POWER KNOB ASS'Y	CBT1A1103ZA	1	
	KNOB,POWER	CBT1A1103B29	1	
	INDICATOR,POWER	CGL1A280Z	1	
8	FUNCTION KNOB ASS'Y	CGK2A126ZA	1	
	CAP,FUNCTION	CGK1A126C64	1	
	KNOB,FUNCTION	CBT1A1102B29	1	
9	BUTTON ,SOURCE	CBT1A1104B29	2	
10	CABINET, TOP	CKC1A188B22	1	
11	HOLDER,PCB	CHE1A030	5	
12	BRACKET,HEAT SINK	CMD1A688	1	
13	HEAT SINK	CMY1A310	1	
14	BRACKET , FAN	CMD1A694	1	
15	FAN,MOTOR<80*80>	CFNKDE1208PTV1	1	
16	FAN,MOTOR<60*60*10>	CFNCF1210S	2	
17				
18				
19	CHASSIS ,BOTTOM	CUA1A292	1	
20	COVER,SCREW	CMD1A495	1	
21	FOOT	CKL1A086	4	
22	RUBBER,FOOT	CHG1A297	4	
23	SUPPDRT,PCB 48	CRE1A075	2	
24	SUPPDRT,PCB 31	CRE1A073	1	
25	SUPPDRT,PCB 44	CRE1A074	1	
26	PANEL,REAR	CKF4A397ZK1	1	
27	AC INLET WIRE ASS'Y	CWZVISDWOCN99A	1	
28	MODULE,TUNER USA	CNVMB014MA0J8LS	1	
29	TRANS,POWER	CLT5W035ZU	1	
30	FRONT PCB ASS'Y	COP12126D	1	
		30-1 COP12126-1	1	
		30-2 COP12126-2	1	
		30-3 COP12126-3	1	
		30-4 COP12126-4	1	
		30-5 COP12126-5	1	
		30-6 COP12126-6	1	
		30-7 COP12126-7	1	
31	MAIN PCB ASS'Y	COP12121D	1	
32	MCU PCB ASS'Y	COP12117D	1	
33	INPUT PCB ASS'Y	COP12118D	1	
		33-1 COP12118-1	1	
		33-2 COP12118-2	1	
		33-3 COP12118-3	1	
34	VIDEO PCB ASS'Y	COP12119D	1	
35	HDMI PCB ASS'Y	COP12120D	1	

NO	DESCRIPTION	PARTS NO.	Q,ty
S1	SCREW	CTB3+8JFZR	53
S2	SCREW	CTWS3+10GR	2
S3	SCREW	CTB4+6FFZR	6
S4	SCREW	CTW3+18JR	13
S5	SCREW	CHD1A012ZR	14
S6	SCREW	CHD4A012R	1
S7	SCREW,SPECIAL	CHD1A036R	4
S8	SCREW,TRANS	CHD1A023R	4
S9	SCREW	CTB3+8JR	2
S10	SCREW	CTB3+10JFZR	24
S11	SCREW	CTB3+6FFZR	13

NOTE **
 AMP ASSEMBLY #31 & CHASSIS #19
 ARE SOLD TOGETHER
 FASCIA ASSEMBLY #1, #3, & #4
 ARE SOLD TOGETHER

T747AH EXPLODED VIEW (Graphite)

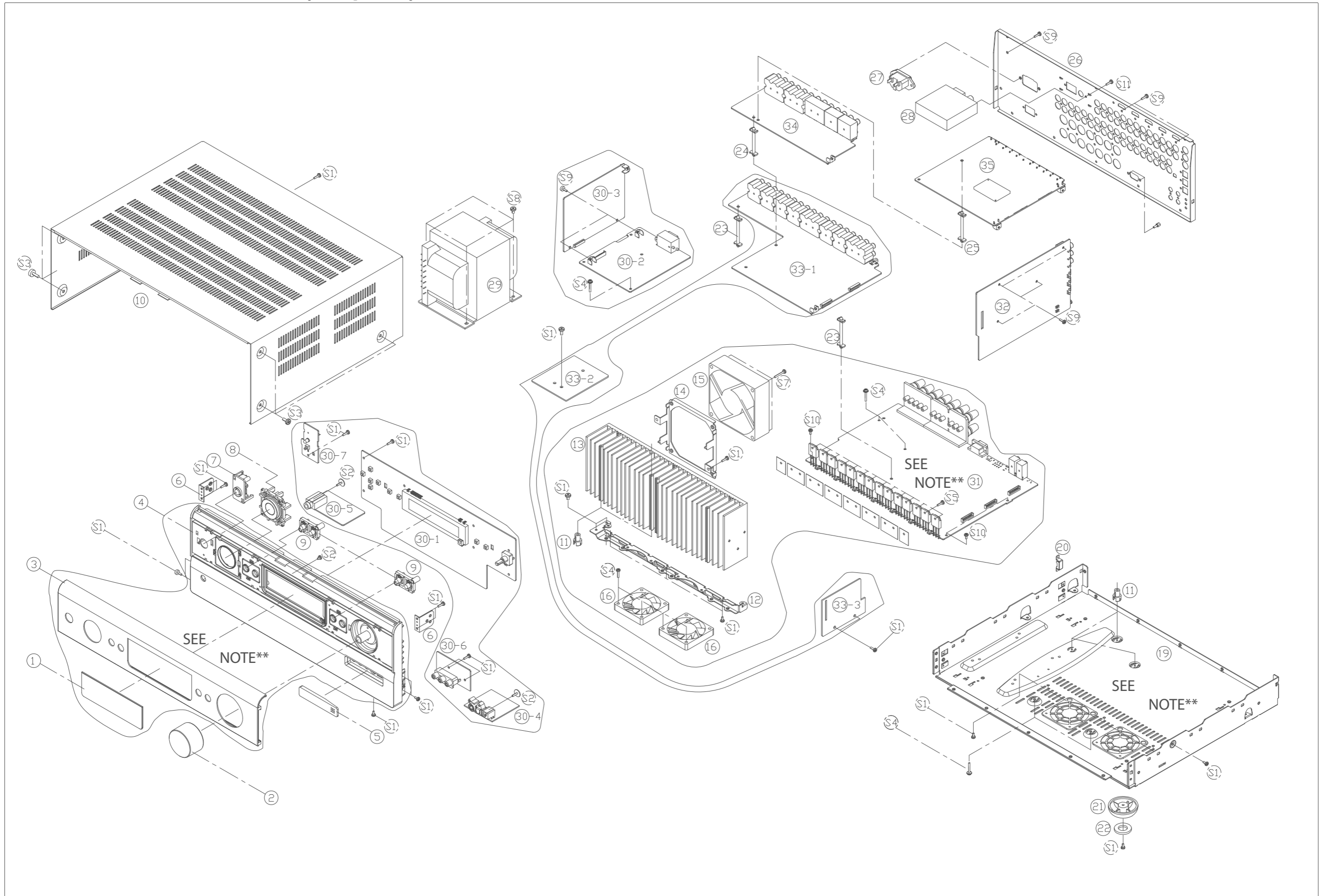

T747C EXPLODED VIEW PARTS LIST (Graphite)

NO	DESCRIPTION	PARTS NO.	Q,ty	REMARK
1	WINDOW ,FIP	CGU1A434Z	1	
2	VOLUME KNOB ASS'Y	CGK1A145ZA	1	
	KNOB,VOLUME	CBN1A216	1	
	CAP,VOLUME	CGK1A145C64	1	
3	PANEL,AL	CKM1A208YC64	1	
4	PANEL,FRONT	CGW2A475RBYB29	1	
5	COVER,JACK	CGR1A476B29	1	
6	BRACKET	CMD2A563	2	
7	POWER KNOB ASS'Y	CBT1A1103ZA	1	
	KNOB,POWER	CBT1A1103B29	1	
	INDICATOR,POWER	CGL1A280Z	1	
8	FUNCTION KNOB ASS'Y	CGK2A126ZA	1	
	CAP,FUNCTION	CGK1A126C64	1	
	KNOB,FUNCTION	CBT1A1102B29	1	
9	BUTTON ,SOURCE	CBT1A1104B29	2	
10	CABINET, TOP	CKC1A188B22	1	
11	HOLDER,PCB	CHE1A030	5	
12	BRACKET,HEAT SINK	CMD1A688	1	
13	HEAT SINK	CMY1A310	1	
14	BRACKET , FAN	CMD1A694	1	
15	FAN,MOTOR(80*80)	CFNKDE1208PTV1	1	
16	FAN,MOTDT(60*60*10)	CFNCF1210S	2	
17				
18				
19	CHASSIS ,BOTTOM	CUA1A292	1	
20	COVER,SCREW	CMD1A495	1	
21	FOOT	CKL1A086	4	
22	RUBBER,FOOT	CHG1A297	4	
23	SUPPORT,PCB 48	CRE1A075	2	
24	SUPPORT,PCB 31	CRE1A073	1	
25	SUPPORT,PCB 44	CRE1A074	1	
26	PANEL,REAR	CKF3A397ZK1	1	
27	AC INLET WIRE ASS'Y	CWZVISOWDCN99A	1	
28	MODULE,TUNER USA	CNVMB014MA1J8L	1	
29	TRANS,POWER	CLT5W035ZE	1	
30	FRONT PCB ASS'Y	CDP12126E	1	
		30-1 CDP12126-1	1	
		30-2 CDP12126-2	1	
		30-3 CDP12126-3	1	
		30-4 CDP12126-4	1	
		30-5 CDP12126-5	1	
		30-6 CDP12126-6	1	
		30-7 CDP12126-7	1	
31	MAIN PCB ASS'Y	CDP12121E	1	
32	MCU PCB ASS'Y	CDP12117E	1	
33	INPUT PCB ASS'Y	CDP12118E	1	
		33-1 CDP12118-1	1	
		33-2 CDP12118-2	1	
		33-3 CDP12118-3	1	
34	VIDEO PCB ASS'Y	CDP12119E	1	
35	HDMI PCB ASS'Y	CDP12120E	1	

NO	DESCRIPTION	PARTS NO.	Q,ty
S1	SCREW	CTB3+8JFZR	53
S2	SCREW	CTWS3+10GR	2
S3	SCREW	CTB4+6FFZR	6
S4	SCREW	CTW3+18JR	13
S5	SCREW	CHD1A012ZR	14
S6	SCREW	CHD4A012R	1
S7	SCREW,SPECIAL	CHD1A036R	4
S8	SCREW,TRANS	CHD1A023R	4
S9	SCREW	CTB3+8JR	2
S10	SCREW	CTB3+10JFZR	24
S11	SCREW	CTB3+6FFZR	13

NOTE **
AMP ASSEMBLY #31 & CHASSIS #19
ARE SOLD TOGETHER
FASCIA ASSEMBLY #1, #3, & #4
ARE SOLD TOGETHER

T747C EXPLODED VIEW (Graphite)

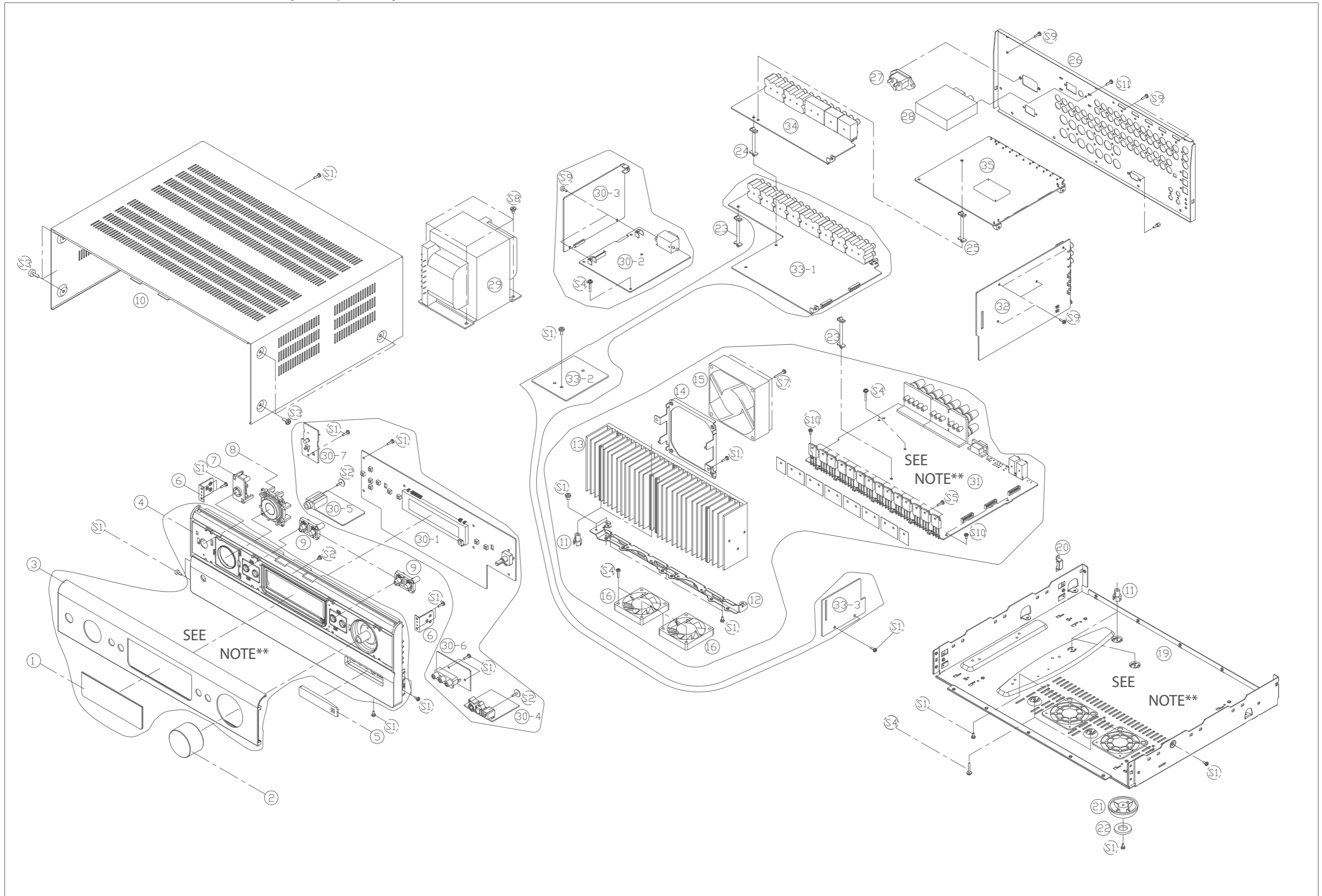

T747CT EXPLODED VIEW PARTS LIST (Titanium)

NO	DESCRIPTION	PARTS NO.	Q,ty	REMARK
1	WINDOW ,FIP	CGU1A434Z	1	
2	VOLUME KNOB ASS'Y	CGK1A145YA	1	
	KNOB,VOLUME	CBN1A216	1	
	CAP,VOLUME	CGK1A145C37	1	
3	PANEL,AL	CKM1A208YC37	1	
4	PANEL,FRONT	CGW2A475RBYG38	1	
5	COVER,JACK	CGR1A476G38	1	
6	BRACKET	CMD2A563	2	
7	POWER KNOB ASS'Y	CBT1A1103YA	1	
	KNOB,POWER	CBT1A1103G38	1	
	INDICATOR,POWER	CGL1A280Y	1	
8	FUNCTION KNOB ASS'Y	CGK2A126YA	1	
	CAP,FUNCTION	CGK1A126C37	1	
	KNOB,FUNCTION	CBT1A1102G38	1	
9	BUTTON ,SOURCE	CBT1A1104B29G38	2	
10	CABINET, TOP	CKC1A188G39	1	
11	HOLDER,PCB	CHE1A030	5	
12	BRACKET,HEAT SINK	CMD1A688	1	
13	HEAT SINK	CMY1A310	1	
14	BRACKET , FAN	CMD1A694	1	
15	FAN,MOTOR<80*80>	CFNKDE1208PTV1	1	
16	FAN,MOTOR<60*60*10>	CFNCF1210S	2	
17				
18				
19	CHASSIS ,BOTTOM	CUA1A292	1	
20	COVER,SCREW	CMD1A495	1	
21	FOOT	CKL1A086	4	
22	RUBBER,FOOT	CHG1A297	4	
23	SUPPORT,PCB 48	CRE1A075	2	
24	SUPPORT,PCB 31	CRE1A073	1	
25	SUPPORT,PCB 44	CRE1A074	1	
26	PANEL,REAR	CKF3A397ZK1	1	
27	AC INLET WIRE ASS'Y	CWZVISDWD0CN99A	1	
28	MODULE,TUNER USA	CNVMB014MA1J8L	1	
29	TRANS,POWER	CLT5W035ZE	1	
30	FRONT PCB ASS'Y	COP12126E	1	
		30-1 COP12126-1	1	
		30-2 COP12126-2	1	
		30-3 COP12126-3	1	
		30-4 COP12126-4	1	
		30-5 COP12126-5	1	
		30-6 COP12126-6	1	
		30-7 COP12126-7	1	
31	MAIN PCB ASS'Y	COP12121E	1	
32	MCU PCB ASS'Y	COP12117E	1	
33	INPUT PCB ASS'Y	COP12118E	1	
		33-1 COP12118-1	1	
		33-2 COP12118-2	1	
		33-3 COP12118-3	1	
34	VIDEO PCB ASS'Y	COP12119E	1	
35	HDMI PCB ASS'Y	COP12120E	1	

NO	DESCRIPTION	PARTS NO.	Q,ty
S1	SCREW	CTB3+8JFZR	48
S2	SCREW	CTWS3+10GR	2
S3	SCREW	CTB4+6FC	6
S4	SCREW	CTW3+18JR	13
S5	SCREW	CHD1A012ZR	14
S6	SCREW	CHD4A012R	1
S7	SCREW,SPECIAL	CHD1A036R	4
S8	SCREW,TRANS	CHD1A023R	4
S9	SCREW	CTB3+8JR	2
S10	SCREW	CTB3+10JFZR	24
S11	SCREW	CTB3+6FFZR	13
S12	SCREW	CTB3+8JFC	5

NOTE **
 AMP ASSEMBLY #31 & CHASSIS #19
 ARE SOLD TOGETHER
 FASCIA ASSEMBLY #1, #3, & #4
 ARE SOLD TOGETHER

T747CT EXPLODED VIEW (Titanium)

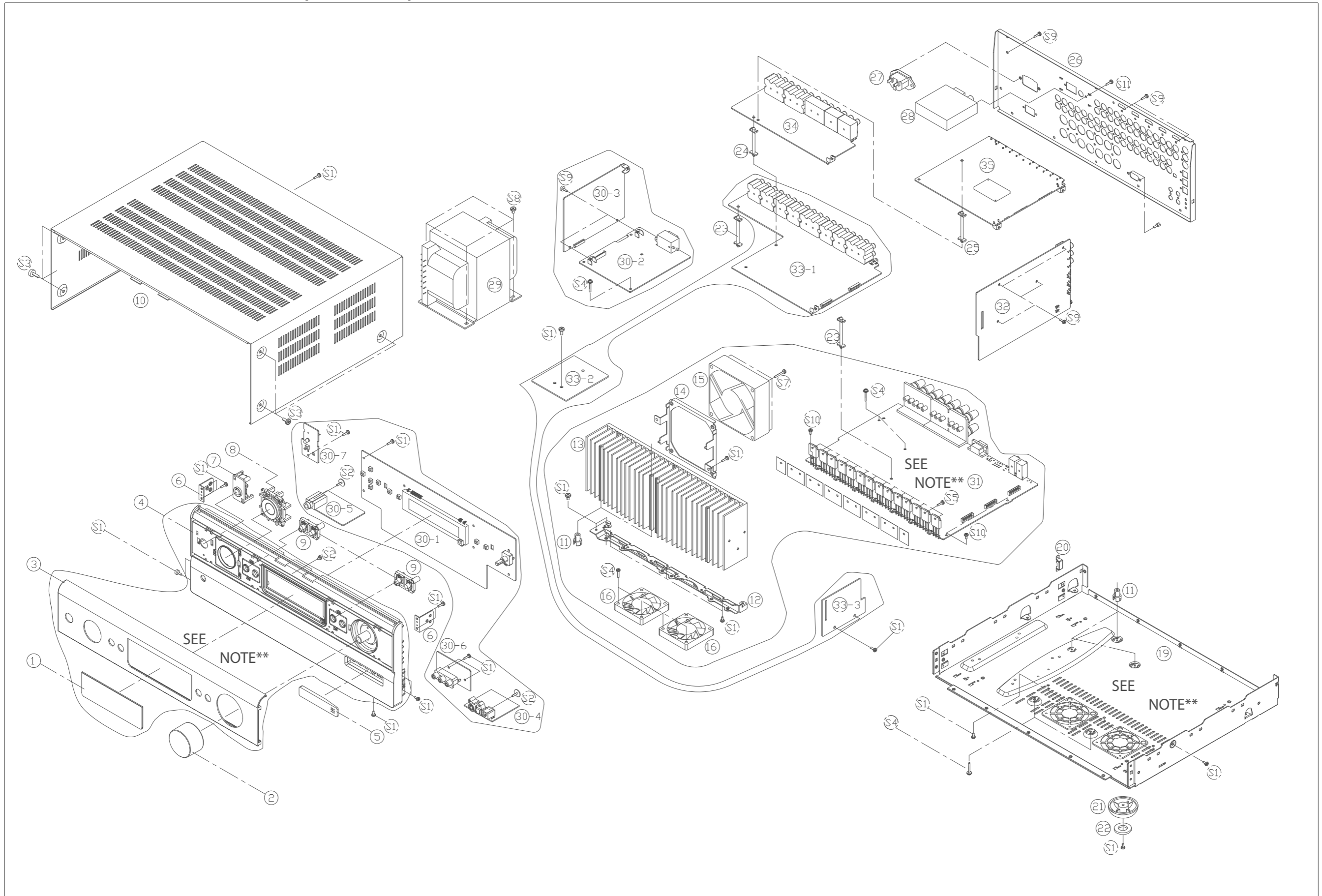

SECTION 2

ELECTRICAL CONTENTS

CONTENTS

IC BLOCK DIAGRAMS & PIN DESCRIPTION	2-2
DIAGRAM	2-31
1. BLOCK DIAGRAM	2-31
2. WIRING DIAGRAM	2-39
3. SCHEMATIC DIAGRAM	2-41
● FRONT PART	2-41
● POWER PART	2-43
● MCU PART	2-45
● DSP&CODEC WITH DIR PART	2-47
● INPUT&VOLUME PART	2-49
● XM&TUNER PART	2-51
● VIDEO PART	2-53
● HDMI PART	2-55
● AMP PART	2-63
4. PRINTED CIRCUIT BOARDS	2-67
● FRONT	2-67
● MAIN	2-71
● INPUT	2-73
● VIDEO	2-77
● HDMI	2-79
● AMP	2-81
5. TROUBLESHOOTING	2-85
6. SPECIAL FUNCTION KEYS	2-89

IC BLOCK DIAGRAMS & PIN DESCRIPTION

IC PIN DECRIBTIONS(IC201 : FLASH u-COM : T5CC1)			
PIN No	Port Name	(I/O)	FUNCTION
1	VREFL		GND
2	AVSS		GND
3	AVCC		3.3V
4	P70/TA0IN	O	VFD_CS
5	P71/TA1OUT	O	VFD_CLK
6	P72/TA3OUT	O	VFD_DATA
7	P73/TA4IN	O	VFD_RST
8	P74/TA5OUT	I	HP_IN
9	P75/TA7OUT	O	UART1_RESET
10	P80/TB0IN0/INT5	I	URAT1_IRQ
11	P81/TB0IN1/INT6	O	UART1_CLK
12	P82/TB0OUT0	O	UART1_CS
13	P83/TB0OUT1	I	UART1_DATA_IN
14	P84/TB1IN0/INT7	O	UART1_DATA_OUT
15	P85/TB1IN1/INT8	I	TORINO_MUTE_IN
16	P86/TB1OUT0	O	HDMI_SW1
17	P87/TB1OUT1	O	HDMI_SW2
18	P90/TXD0	O	TORINO_TX
19	P91/RXD0	I	TORINO_RX
20	P92/SCLK0/CTS0	O	TORINO_RESET
21	P93/TXD1	O	UART_TX
22	P94/RXD1	I	UART_RX
23	P95/SCLK1/CTS1	I	DSP_MODE_SEL
24	AM0		3.3V
25	DVCC		3.3V
26	X2	O	X_TAL_OUT
27	DVSS		GND
28	X1	I	X_TAL_IN
29	AM1		3.3V
30	RE	I	RESET
31	P96/XT1	I	
32	P97/XT2	I	
33	EMU0		
34	EMU1		
35	PA0/INT1		REMOTE_IN
36	PA1/INT2		MULTI_IR_IN
37	PA2/INT3		RDS_CLK
38	PA3/INT4	I	BACK_UP
39	PA4	O	PLL-CE
40	PA5	I	PLL_DATA_IN
41	PA6	O	PLL_CLK
42	PA7	O	PLL_DATA_OUT
43	ALE		N.C
44	P00/AD0	I	TUNED
45	P01/AD1	I	STEREO
46	P02/AD2	I	RDS_DATA
47	P03/AD3	I	OPTION
48	P04/AD4	I	OPTION
49	P05/AD5	O	SCL(EEPROM)
50	P06/AD6	I/O	SDA(EEPROM)

PIN No	Port Name	(I/O)	FUNCTION
51	P07/AD7	I	PROTECT_IN
52	P10/AD8/A8	O	SUB_VOL_STB
53	P11/AD9/A9	O	SUB_VOL_CLK
54	P12/AD10/A10	O	SUB_VOL_DATA
55	P13/AD11/A11	O	MAIN_VOL_MUTE
56	P14/AD12/A12	O	MAIN_VOL_CLK
57	P15/AD13/A13	O	MAIN_VOL_DATA
58	P16/AD14/A14	O	FUNCTION_MUTE
59	P17/AD15/A15	O	EXP_CE2
60	P20/A0/A16	O	DIR_RESET
61	P21/A1/A17	O	DIR_CS
62	DVSS		GND
63	NMI		3.3V
64	DVCC		3.3V
65	P22/A2/A18	I	DIR_D_OUT
66	P23/A3/A19	I	DSP_SPC1_IRQ
67	P24/A4/A20	O	DSP_DIR_CLK
68	P25/A5/A21	I	DSP_DATA
69	P26/A6/A22	O	DSP_CS
70	P27/A7/A23	O	DSP_DIR_DATA
71	P30/RD	O	HDMI_SW1
72	P31/WR	O	HDMI_SW2
73	P32/HWR	I	DSP_PCP_BSY
74	P33/WAIT	O	DSP_RESET
75	P34/BUSRQ	O	EXP_CE1
76	P35/BUSAK	O	EXP_CLK
77	P36/R/W	O	EXP_DATA
78	P37/BOOT	I	BOOT_MODE
79	P40/CS0	I	URAT2_IRQ
80	P41/CS1	O	UART2_CLK
81	P42/CS2	O	UART2_CS
82	P43/CS3	I	UART2_DATA_IN
83	P60/SCK	O	UART2_DATA_OUT
84	P61/SO/SDA	O	UART2_RESET
85	P62/SI/SCL	O	VIDEO_SDA
86	P63/INT0		VIDEO_SCL
87	P64/SCOUT	O	POWER_ON
88	P65	O	MIC_ON
89	DVCC		3.3V
90	P66	I	IPOD_DETECT
91	DVSS		GND
92	P50/AN0	I	KEY1
93	P51/AN1	I	KEY2
94	P52/AN2	I	KEY3
95	P53/AN3/ADTRG	I	VOL_EN1
96	P54/AN4	I	VOL_EN2
97	P55/AN5		FUNC_EN1
98	P56/AN6		FUNC_EN2
99	P57/AN7		HDMI_INT
100	VREFH		3.3V

IC201: T5CC1: Microcontrollers

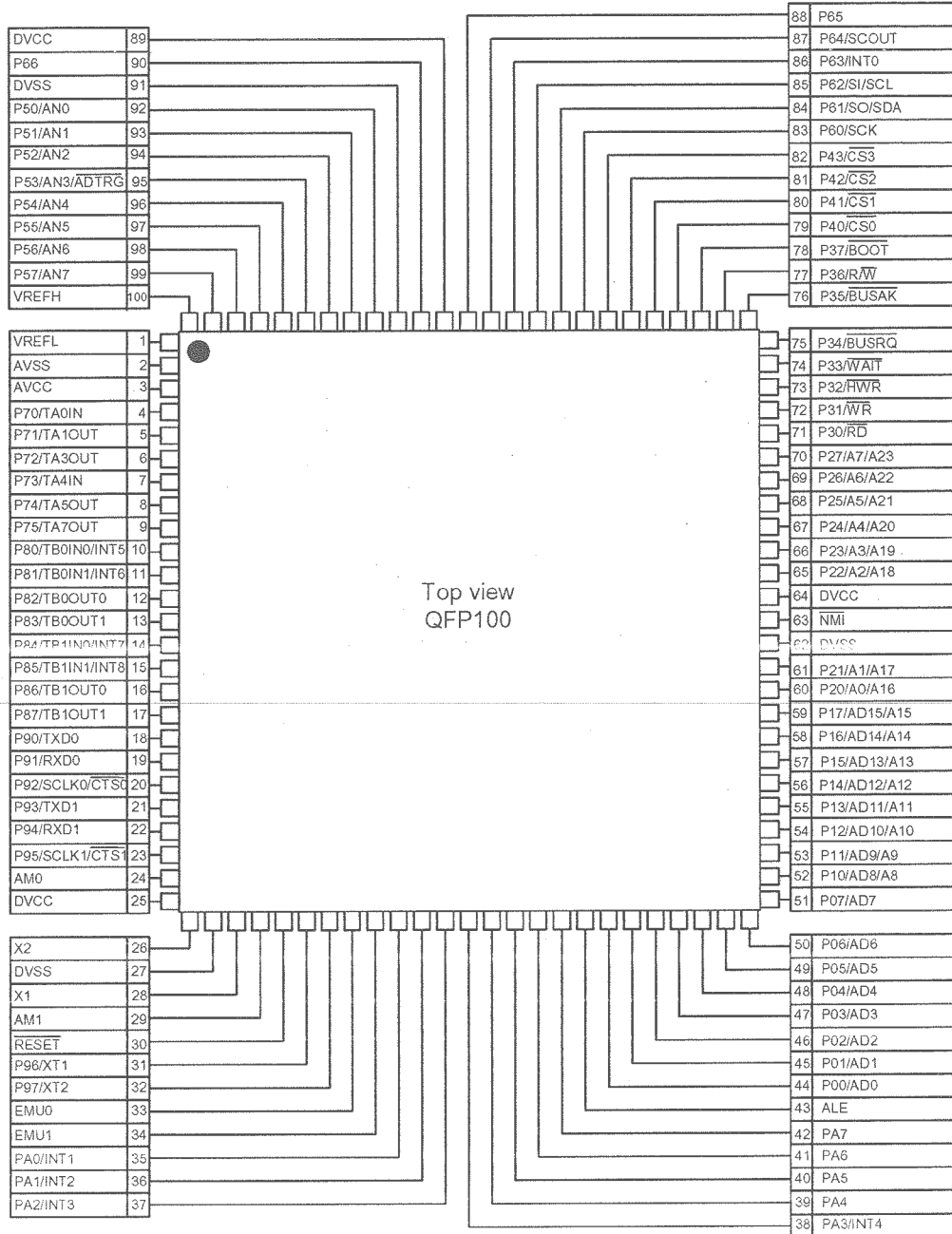

IC PIN DESCRIPTION (IC158: ADV7342: VIDEO ENCODER)

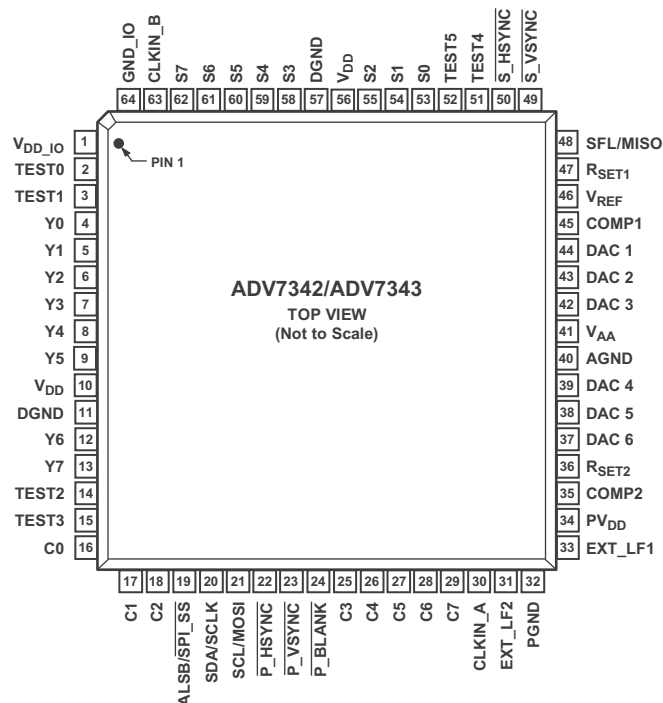

Pin No.	Mnemonic	Input/ Output	Description
13, 12, 9 to 4	Y7 to Y0	I	8-Bit Pixel Port. Y0 is the LSB. Refer to Table 31 for input modes.
29 to 25, 18 to 16	C7 to C0	I	8-Bit Pixel Port. C0 is the LSB. Refer to Table 31 for input modes.
62 to 58, 55 to 53	S7 to S0	I	8-Bit Pixel Port. S0 is the LSB. Refer to Table 31 for input modes.
52, 51, 15, 14, 3, 2	TEST5 to TEST0	I	Unused. These pins should be connected to DGND.
30	CLKIN_A	I	Pixel Clock Input for HD Only (74.25 MHz), ED ¹ Only (27 MHz or 54 MHz) or SD Only (27 MHz).
63	CLKIN_B	I	Pixel Clock Input for Dual Modes Only. Requires a 27 MHz reference clock for ED operation or a 74.25 MHz reference clock for HD operation.
50	$\overline{S_HSYNC}$	I/O	SD Horizontal Synchronization Signal. This pin can also be configured to output an SD, ED, or HD horizontal synchronization signal. See the External Horizontal and Vertical Synchronization Control section.
49	$\overline{S_VSYNC}$	I/O	SD Vertical Synchronization Signal. This pin can also be configured to output an SD, ED, or HD vertical synchronization signal. See the External Horizontal and Vertical Synchronization Control section.
22	$\overline{P_HSYNC}$	I	ED/HD Horizontal Synchronization Signal. See the External Horizontal and Vertical Synchronization Control section.
23	$\overline{P_VSYNC}$	I	ED/HD Vertical Synchronization Signal. See the External Horizontal and Vertical Synchronization Control section.
24	$\overline{P_BLANK}$	I	ED/HD Blanking Signal. See the External Horizontal and Vertical Synchronization Control section.
48	SFL/MISO	I/O	Multifunctional Pin: Subcarrier Frequency Lock (SFL) Input/SPI Data Output. The SFL input is used to drive the color subcarrier DDS system, timing reset, or subcarrier reset.
47	RSET1	I	This pin is used to control the amplitudes of the DAC 1, DAC 2, and DAC 3 outputs. For full-drive operation (for example, into a 37.5 Ω load), a 510 Ω resistor must be connected from RSET1 to AGND. For low drive operation (for example, into a 300 Ω load), a 4.12 k Ω resistor must be connected from RSET1 to AGND.

Pin No.	Mnemonic	Input/ Output	Description
36	R _{SET2}	I	This pin is used to control the amplitudes of the DAC 4, DAC 5, and DAC 6 outputs. A 4.12 k Ω resistor must be connected from R _{SET2} to AGND.
45, 35	COMP1, COMP2	O	Compensation Pins. Connect a 2.2 nF capacitor from both COMP pins to V _{AA} .
44, 43, 42	DAC 1, DAC 2, DAC 3	O	DAC Outputs. Full and low drive capable DACs.
39, 38, 37	DAC 4, DAC 5, DAC 6	O	DAC Outputs. Low drive only capable DACs.
21	SCL/MOSI	I	Multifunctional Pin: I ² C Clock Input/SPI Data Input.
20	SDA/SCLK	I/O	Multifunctional Pin: I ² C Data Input/Output. Also, SPI clock input.
19	ALSB/SPI_SS	I	Multifunctional Pin: This signal sets up the LSB ² of the MPU I ² C address. Also, SPI slave select.
46	V _{REF}		Optional External Voltage Reference Input for DACs or Voltage Reference Output.
41	V _{AA}	P	Analog Power Supply (3.3 V).
10, 56	V _{DD}	P	Digital Power Supply (1.8 V). For dual-supply configurations, V _{DD} can be connected to other 1.8 V supplies through a ferrite bead or suitable filtering.
1	V _{DD_IO}	P	Input/Output Digital Power Supply (3.3 V).
34	PV _{DD}	P	PLL Power Supply (1.8 V). For dual-supply configurations, PV _{DD} can be connected to other 1.8 V supplies through a ferrite bead or suitable filtering.
33	EXT_LF1	I	External Loop Filter for On-Chip PLL 1.
31	EXT_LF2	I	External Loop Filter for On-Chip PLL 2.
32	PGND	G	PLL Ground Pin.
40	AGND	G	Analog Ground Pin.
11, 57	DGND	G	Digital Ground Pin.
64	GND_IO	G	Input/Output Supply Ground Pin.

IC240: CS497004: DSP

GPIO9, PCP_A1 / A9	108	GPIO41, PCP_IRQ#	108	SD_A0, EXT_A0	72
GPIO8, PCP_A0 / A8	110	GPIO40, PCP_RD# / RW#		SD_A1, EXT_A1	
GPIO7, PCP_AD7 / D7		GPIO10, PCP_A2 / A10, SCP2_MOSI		SD_A2, EXT_A2	70
GPIO6, PCP_AD6 / D6		GPIO11, PCP_A3, AS#, SCP2_MISO / SDA	105	GND4	69
VDDIO7	113	GPIO39, PCP_CS#, SCP2_CS#		SD_A3, EXT_A3	
GPIO5, PCP_AD5 / D5		GPIO38, PCP_WR# / DS#, SCP2_CLK		SD_A4, EXT_A4	
GPIO4, PCP_AD4 / D4	115	GPIO37, SCP1_BSY#, PCP_BSY#		VDD4	66
GNDIO7	116	GND6	101	EXT_CS2#	65
GPIO3, PCP_AD3 / D3		GPIO36, SCP1_IRQ#	100	SD_A5, EXT_A5	
GPIO2, PCP_AD2 / D2		GPIO35, SCP1_CLK		GNDIO4	63
VDD7	119	VDD6	98	SD_A6, EXT_A6	
GPIO1, PCP_AD1 / D1	120	GPIO34, SCP1_MISO / SDA		SD_A7, EXT_A7	
GPIO0, PCP_AD0 / D0		GPIO32, SCP1_CS#, IOWAIT		VDDIO4	60
GND7	122	GPIO33, SCP1_MOSI	95	SD_A8, EXT_A8	
XTAL_OUT		GNDIO6	94	SD_A9, EXT_A9	
XTI		RESET#		GND3	57
XTO	125	GPIO30, XMTB_IN		SD_A11, EXT_A11	
GND4	126	VDDIO6	91	SD_A12, EXT_A12	55
NC		EXT_CS1#	90	VDD3	54
PLL_REF_RES		EXT_OE#		SD_CLKEN	
VDDA (3.3V)	129	EXT_A19		SD_CLKIN	
VDD8	130	EXT_A18		SD_CLKOUT	
GPIO14, DAH1_DATA3, TM3, DSD3		GND5	86	SD_DQM1	50
GPIO13, DAH1_DATA2, TM2, DSD2		EXT_A17	85	SD_D8, EXT_D8	
GND8	133	EXT_A16		SD_D9, EXT_D9	
GPIO12, DAH1_DATA1, TM1, DSD1		VDD5	83	GNDIO3	47
DAH1_DATA0, TM0, DSD0	135	EXT_A15		SD_D10, EXT_D10	
VDDIO8	136	SD_CS#		SD_D11, EXT_D11	45
DAH1_SCLK, DSD-CLK		SD_RAS#	80	VDDIO3	44
DAH1_LRCLK, DSD4		SD_CAS#		SD_D12, EXT_D12	
GNDIO8	139	SD_WEF		SD_D13, EXT_D13	
GPIO42, BDI_REQ# , DA12_LRCLK, PCP_IRQ# / BSY#	140	SD_BA1, EXT_A14		SD_D14, EXT_D14	
GPIO43, BDI_CLK, DA12_SCLK		GNDIO5	76	SD_D15, EXT_D15	40
BDI_DATA, DA12_DATA, DSD5		SD_A10, EXT_A10		SD_D0, EXT_D0	
GPIO27		VDDIO5	73	EXT_WE#	
GPIO26	144			SD_D1, EXT_D1	37
GPIO28, DDAC	1				
GPIO29, XMTA_IN					
DBDA					
DBCK					
GPIO21, DA02_DATA3 / XMTB, UART_TX_ENABLE	5				
GPIO20, DA02_DATA2					
GPIO19, DA02_DATA1, HS4					
DAO_MCLK					
TEST	9				
VDD1	10				
GPIO18, DA02_DATA0, HS3					
GPIO22, DA02_SCLK					
GND1	13				
GPIO23, DA02_LRCLK					
GPIO17, DA01_DATA3 / XMTA	15				
GPIO16, DA01_DATA2, HS2					
GPIO15, DA01_DATA1, HS1					
VDDIO1	18				
DA01_DATA0, HS0					
DAO1_SCLK					
GNDIO1	21				
DAO1_LRCLK					
GPIO31, UART_CLK					
VDD2	24				
GPIO25, UART_TXD, EE_CS#	25				
GPIO24, UART_RXD					
GND2	27				
SD_DM0					
SD_D7, EXT_D7					
SD_D6, EXT_D6	30				
SD_D5, EXT_D5					
SD_D4, EXT_D4					
VDDIO2	33				
SD_D3, EXT_D3					
SD_D2, EXT_D2	35				
GNDIO2	36				

CS497xx4
144-Pin LQFP

IC PIN DESCRIPTION (IC153: A3S56D40ETP: DDR RAM)

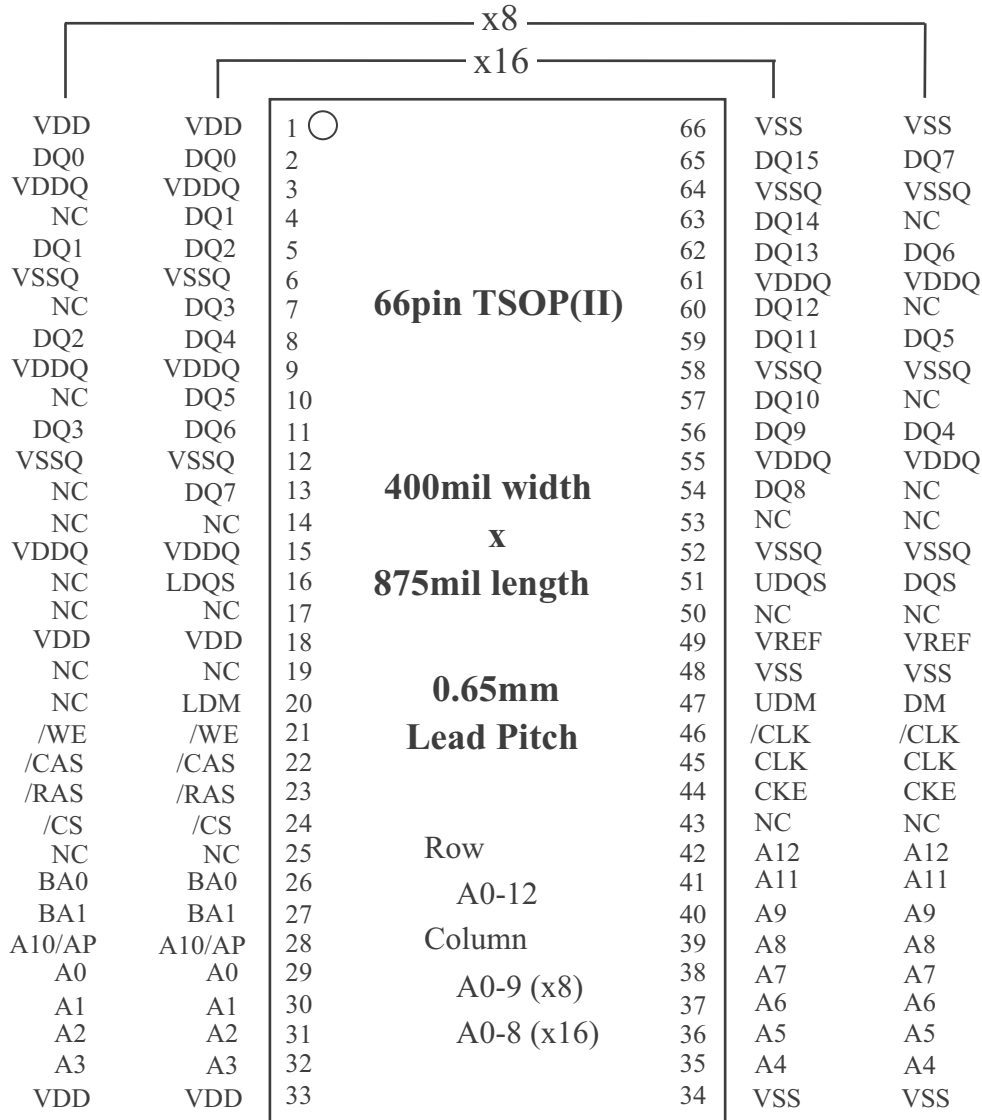

CLK, /CLK	: Master Clock	A0-12	: Address Input
CKE	: Clock Enable	BA0,1	: Bank Address Input
/CS	: Chip Select	Vdd	: Power Supply
/RAS	: Row Address Strobe	VddQ	: Power Supply for Output
/CAS	: Column Address Strobe	Vss	: Ground
/WE	: Write Enable	VssQ	: Ground for Output
DQ0-15	: Data I/O (x16)		
DQ0-7	: Data I/O (x8)		
UDM, LDM	: Write Mask (x16)		
DM	: Write Mask (x8)		
UDQS, LDQS	: Data Strobe (x16)		
DQS	: Data Strobe (x8)		

SYMBOL	TYPE	DESCRIPTION
CLK, /CLK	Input	Clock: CLK and /CLK are differential clock inputs. All address and control input signals are sampled on the crossing of the positive edge of CLK and negative edge of /CLK. Output (read) data is referenced to the crossings of CLK and /CLK (both directions of crossing).
CKE	Input	Clock Enable: CKE controls internal clock. When CKE is low, internal clock for the following cycle is ceased. CKE is also used to select auto / self refresh. After self refresh mode is started, CKE becomes asynchronous input. Self refresh is maintained as long as CKE is low.
/CS	Input	Chip Select: When /CS is high, any command means No Operation.
/RAS, /CAS, /WE	Input	Combination of /RAS, /CAS, /WE defines basic commands.
A0-12	Input	A0-12 specify the Row / Column Address in conjunction with BA0,1. The Row Address is specified by A0-12. The Column Address is specified by A0-9(x8) and A0-8(x16). A10 is also used to indicate precharge option. When A10 is high at a read / write command, an auto precharge is performed. When A10 is high at a precharge command, all banks are precharged.
BA0,1	Input	Bank Address: BA0,1 specifies one of four banks to which a command is applied. BA0,1 must be set with ACT, PRE, READ, WRITE commands.
DQ0-7 (x8), DQ0-15 (x16),	Input / Output	Data Input/Output: Data bus
DQS (x8) UDQS, LDQS (x16)	Input / Output	Data Strobe: Output with read data, input with write data. Edge-aligned with read data, centered in write data. Used to capture write data. For the x16, LDQS corresponds to the data on DQ0-DQ7; UDQS correspond to the data on DQ8-DQ15
DM (x8) UDM, LDM (x16)	Input	Input Data Mask: DM is an input mask signal for write data. Input data is masked when DM is sampled HIGH along with that input data during a WRITE access. DM is sampled on both edges of DQS. Although DM pins are input only, the DM loading matches the DQ and DQS loading. For the x16, LDM corresponds to the data on DQ0-DQ7; UDM corresponds to the data on DQ8-DQ15.
Vdd, Vss	Power Supply	Power Supply for the memory array and peripheral circuitry.
VddQ, VssQ	Power Supply	VddQ and VssQ are supplied to the Output Buffers only.
Vref	Input	SSTL_2 reference voltage.

BLOCK DIAGRAM

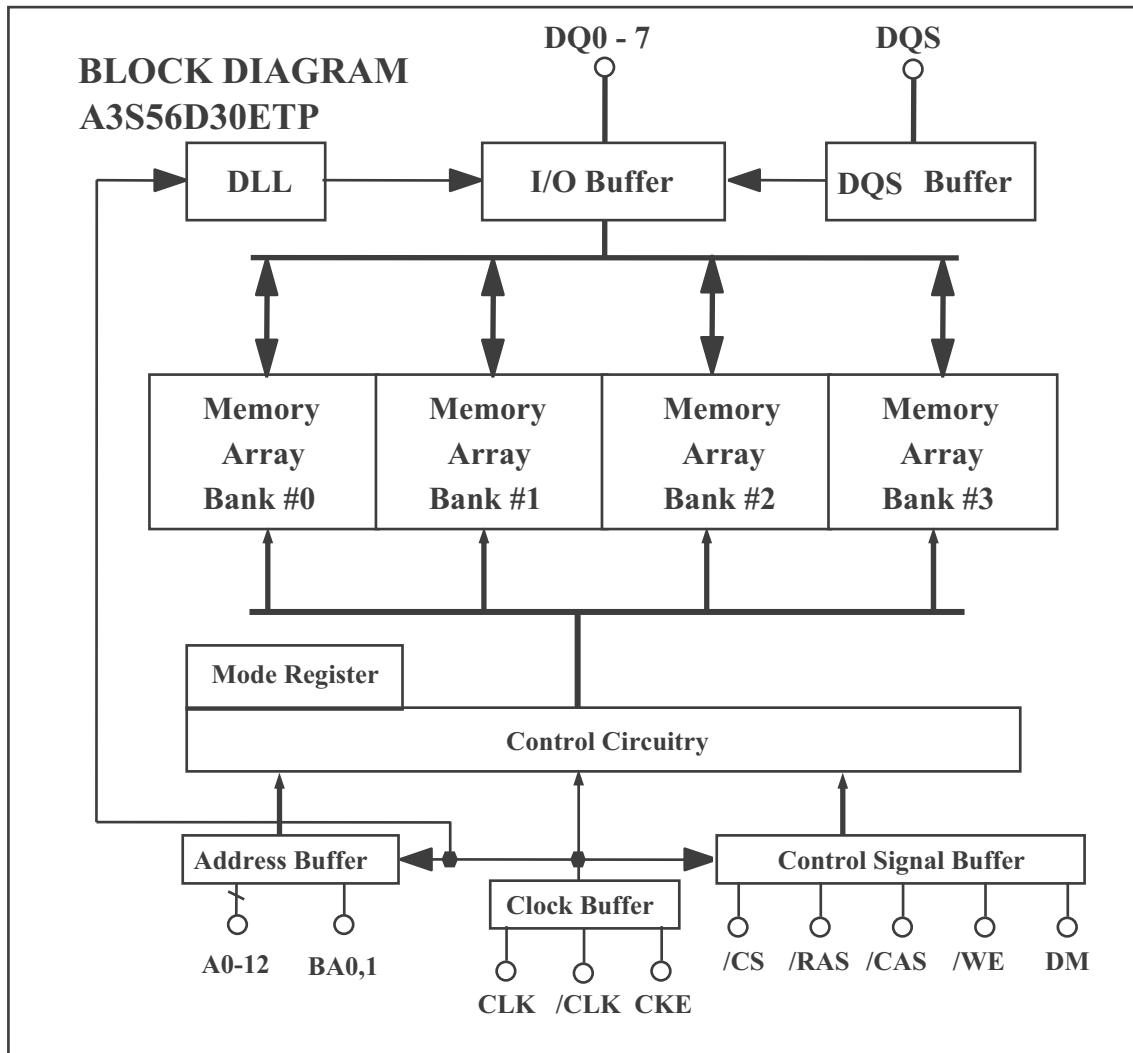

BLOCK DIAGRAM (IC152: ES29LV320FT70TG)

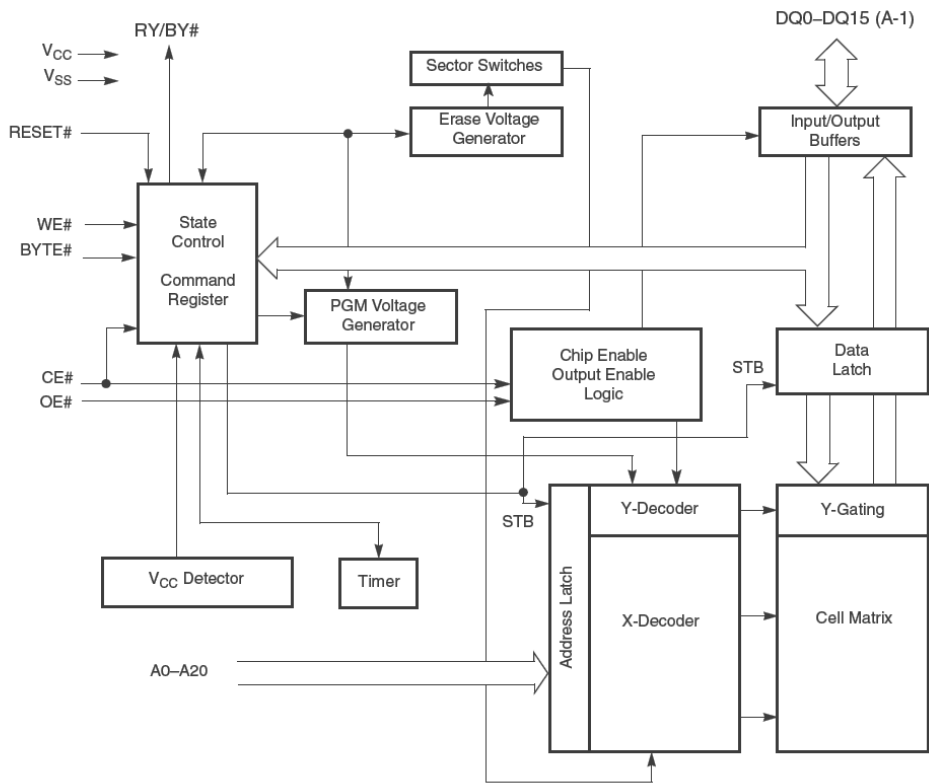

BLOCK DIAGRAM (IC151: FLI30336AC)

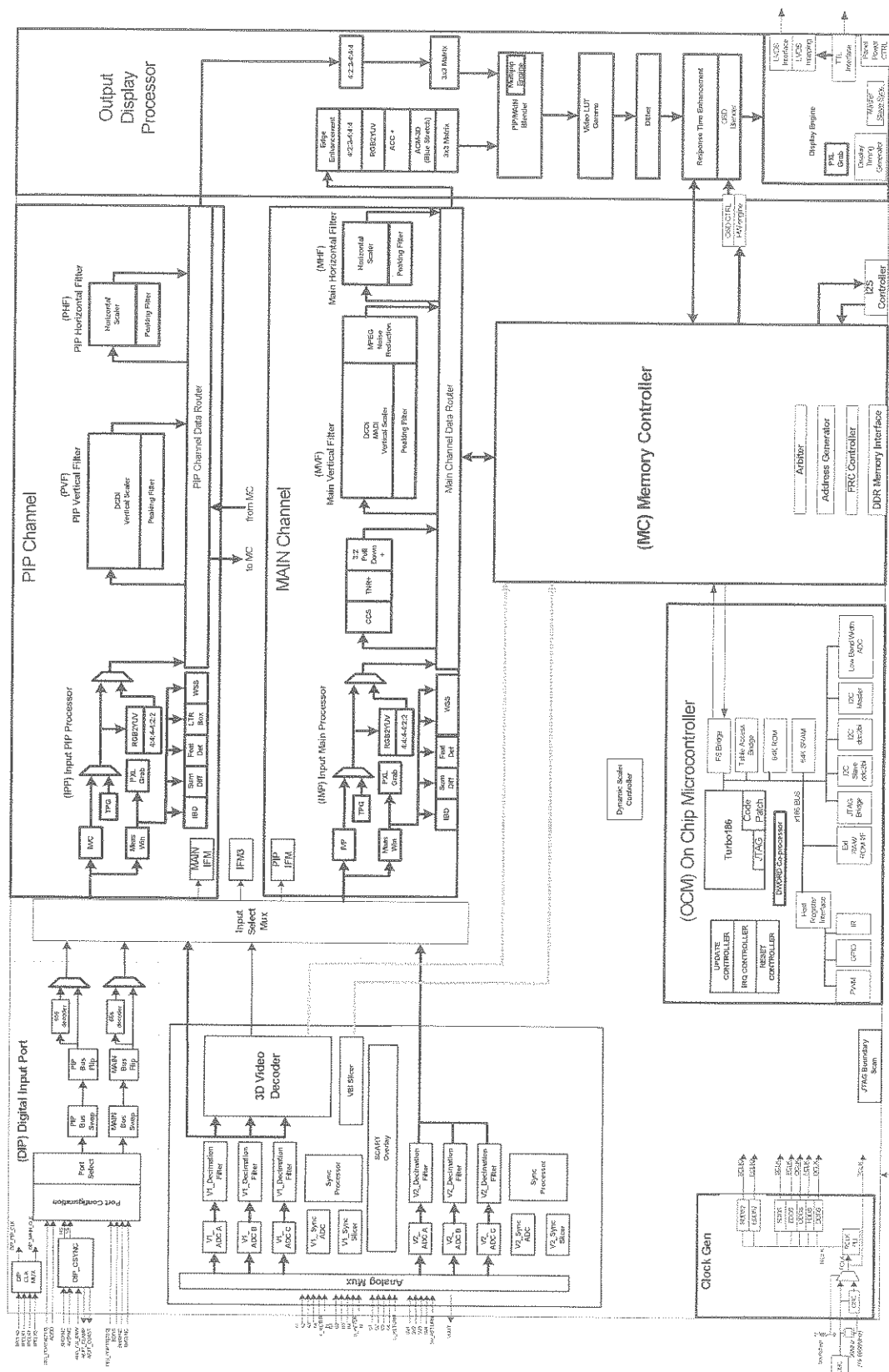

BLOCK DIAGRAM (IC134: NJM2285)

■ BLOCK DIAGRAM

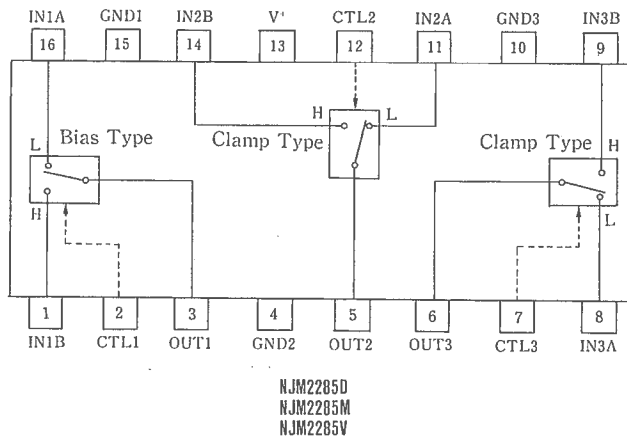

IC113: NJM2566V: VIDEO AMP)

■ BLOCK DIAGRAM

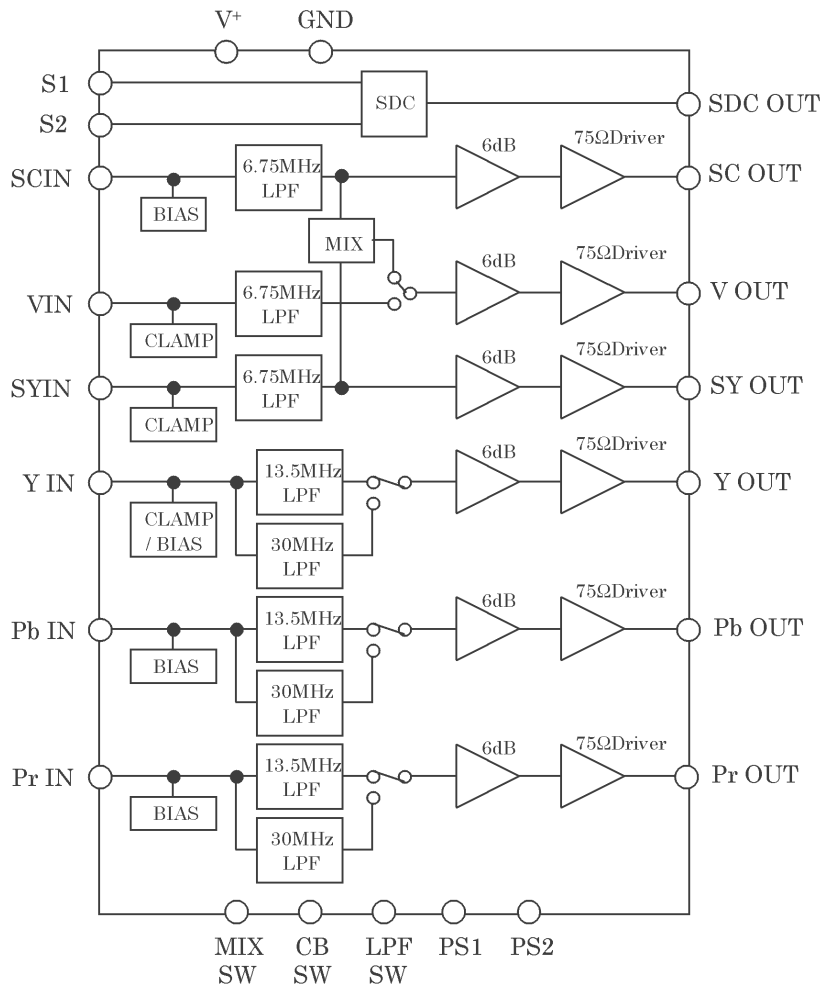

■ PIN CONFIGURATION

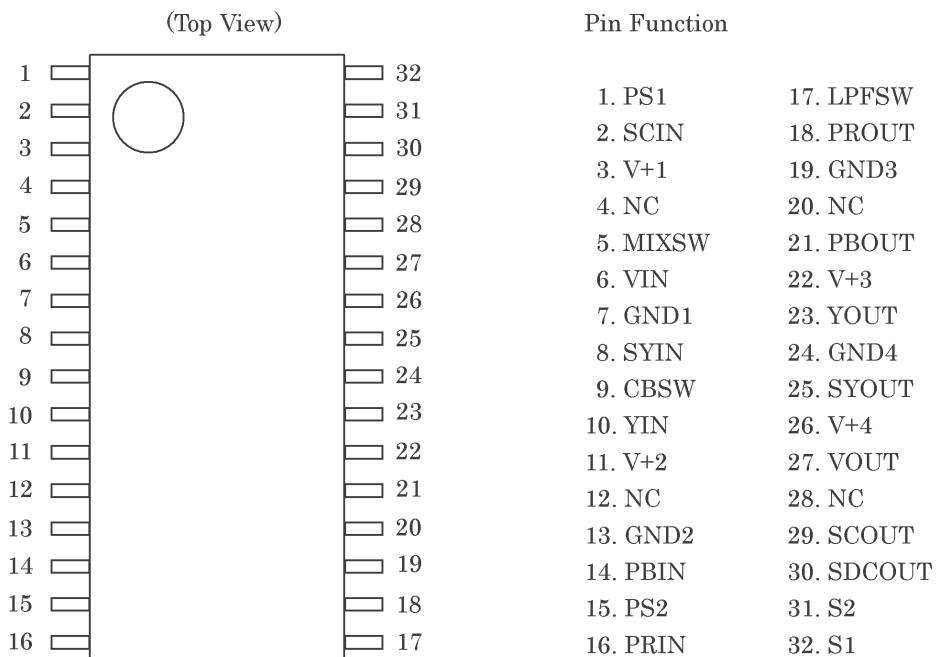

BLOCK DIAGRAM (IC133: NJM2581)

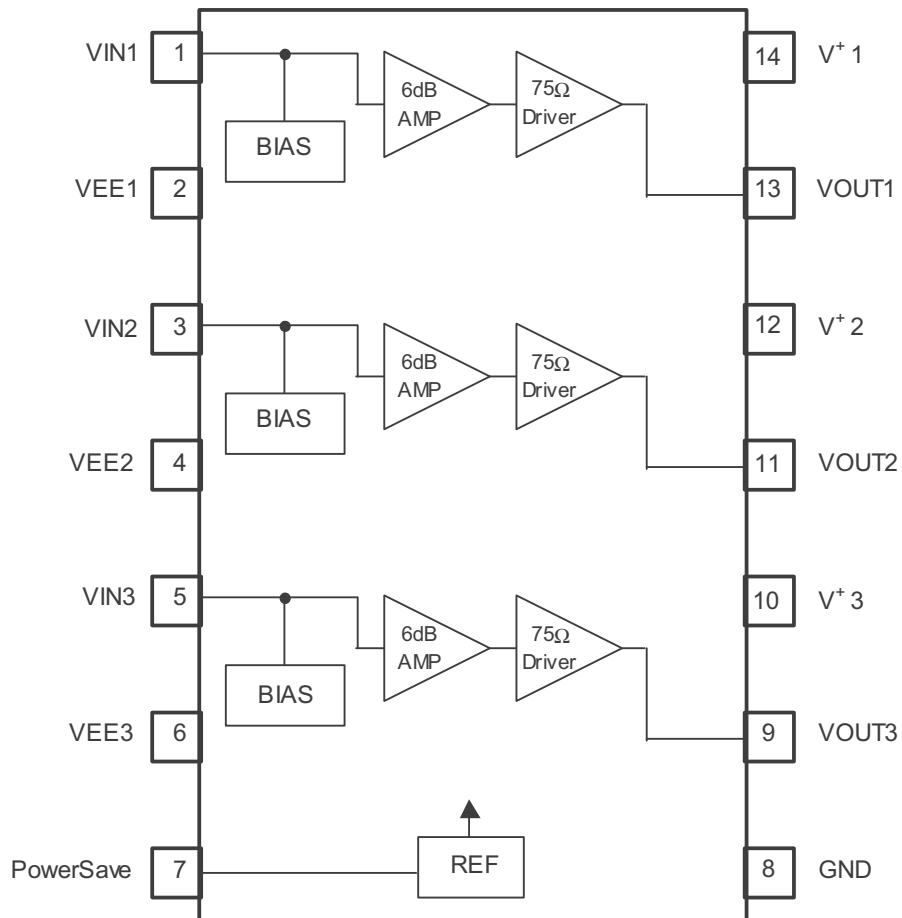

BLOCK DIAGRAM (IC135: NJM2586A)

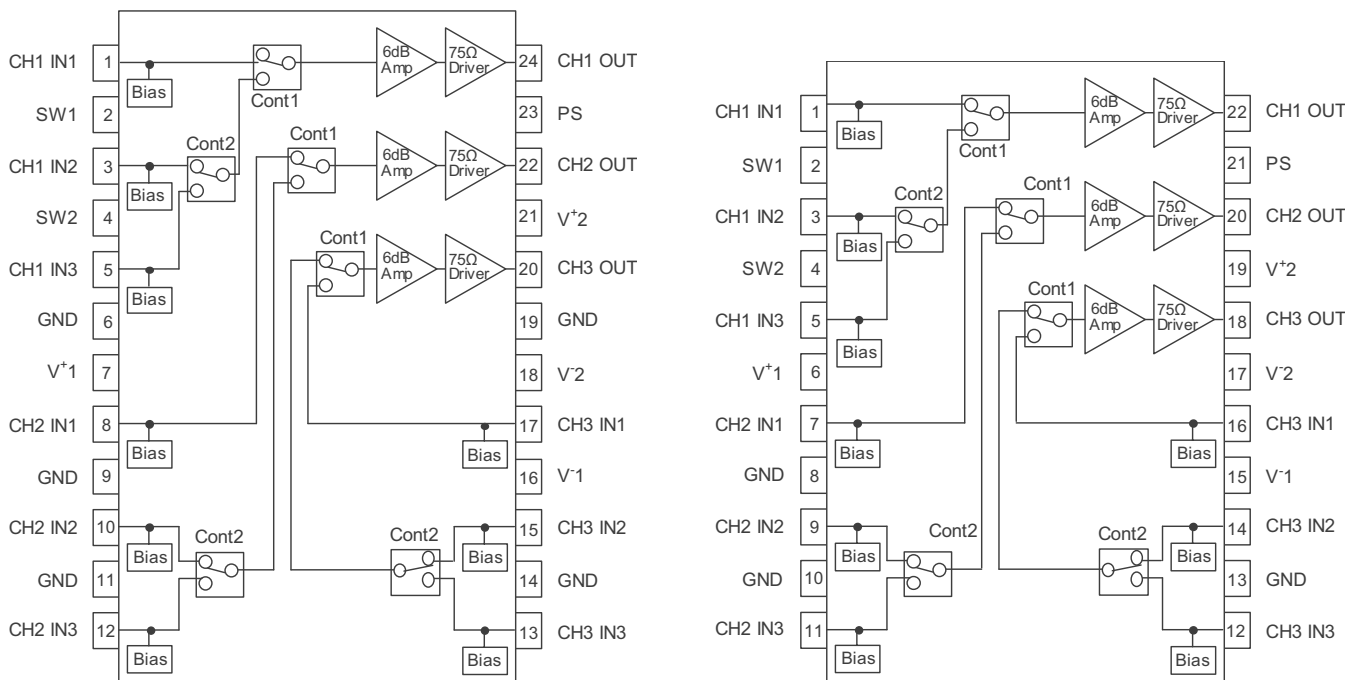

DMP24

SDIP22

IC131: NJW1321FP: VIDEO SW)

■ BLOCK DIAGRAM

BDE-45523-000-00

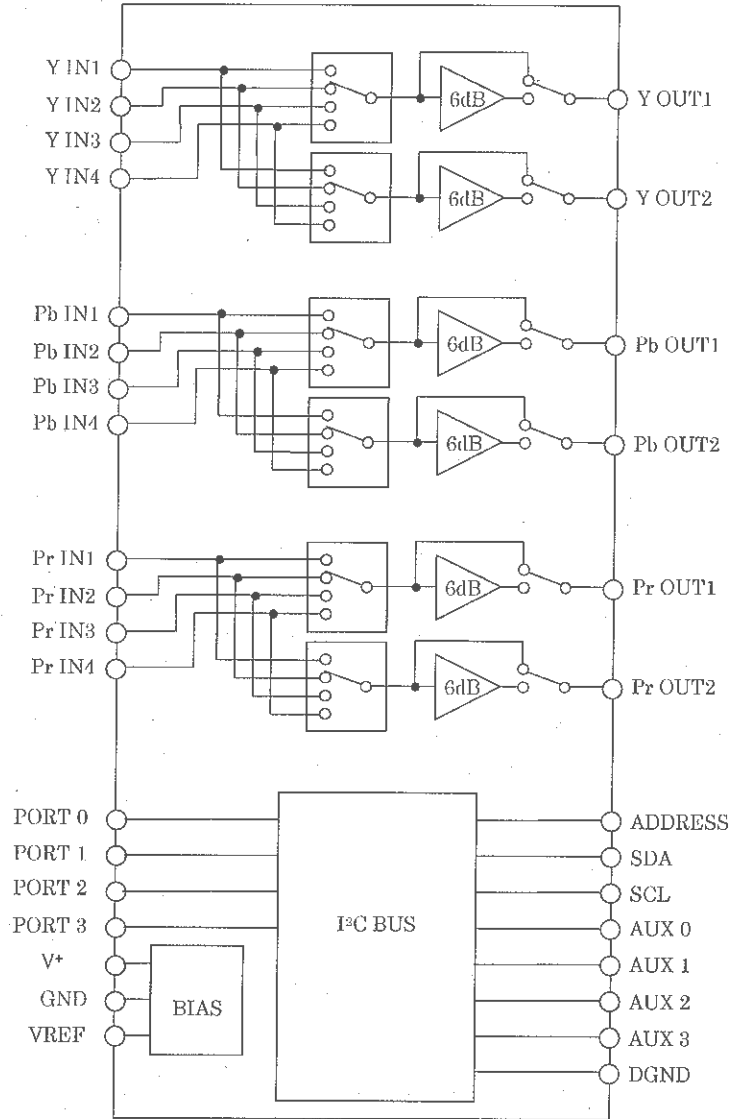

■ PIN CONFIGURATION

BEE-45523-000-00

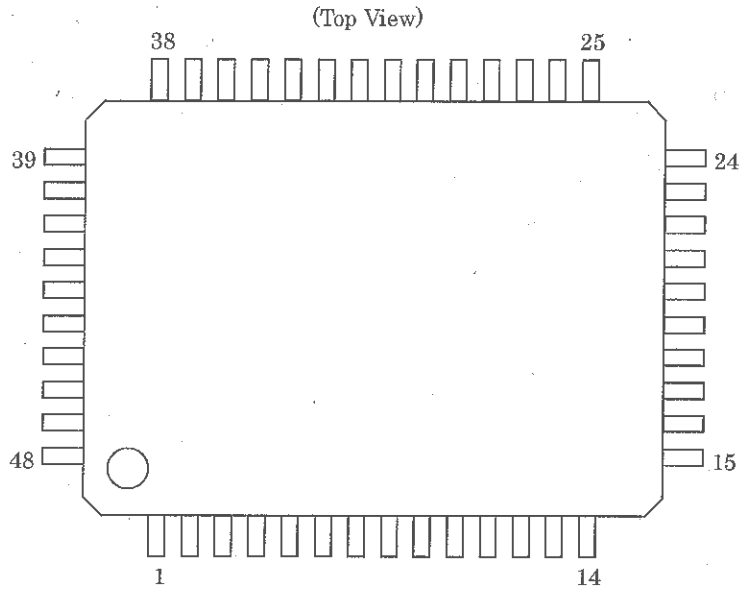

Pin Function

No.	SYMBOL	No.	SYMBOL	No.	SYMBOL
1.	V ⁺	17.	GND	33.	GND
2.	Pb IN2	18.	DGND	34.	Y OUT1
3.	GND	19.	VREF	35.	V ⁺
4.	Pr IN2	20.	V ⁺	36.	Y IN4
5.	GND	21.	Pr OUT2	37.	V ⁺
6.	Y IN1	22.	PORT1	38.	Pb IN4
7.	V ⁺	23.	PORT0	39.	GND
8.	Pb IN1	24.	Pb OUT2	40.	Pr IN4
9.	V ⁺	25.	AUX0	41.	V ⁺
10.	Pr IN1	26.	AUX1	42.	Y IN3
11.	GND	27.	Y OUT2	43.	GND
12.	PORT3	28.	AUX2	44.	Pb IN3
13.	PORT2	29.	AUX3	45.	V ⁺
14.	ADR	30.	Pr OUT1	46.	Pr IN3
15.	SCL	31.	GND	47.	GND
16.	SDA	32.	Pb OUT1	48.	Y IN2

IC301: R2A15218FP: 8CH ELECTRONIC VOLUME

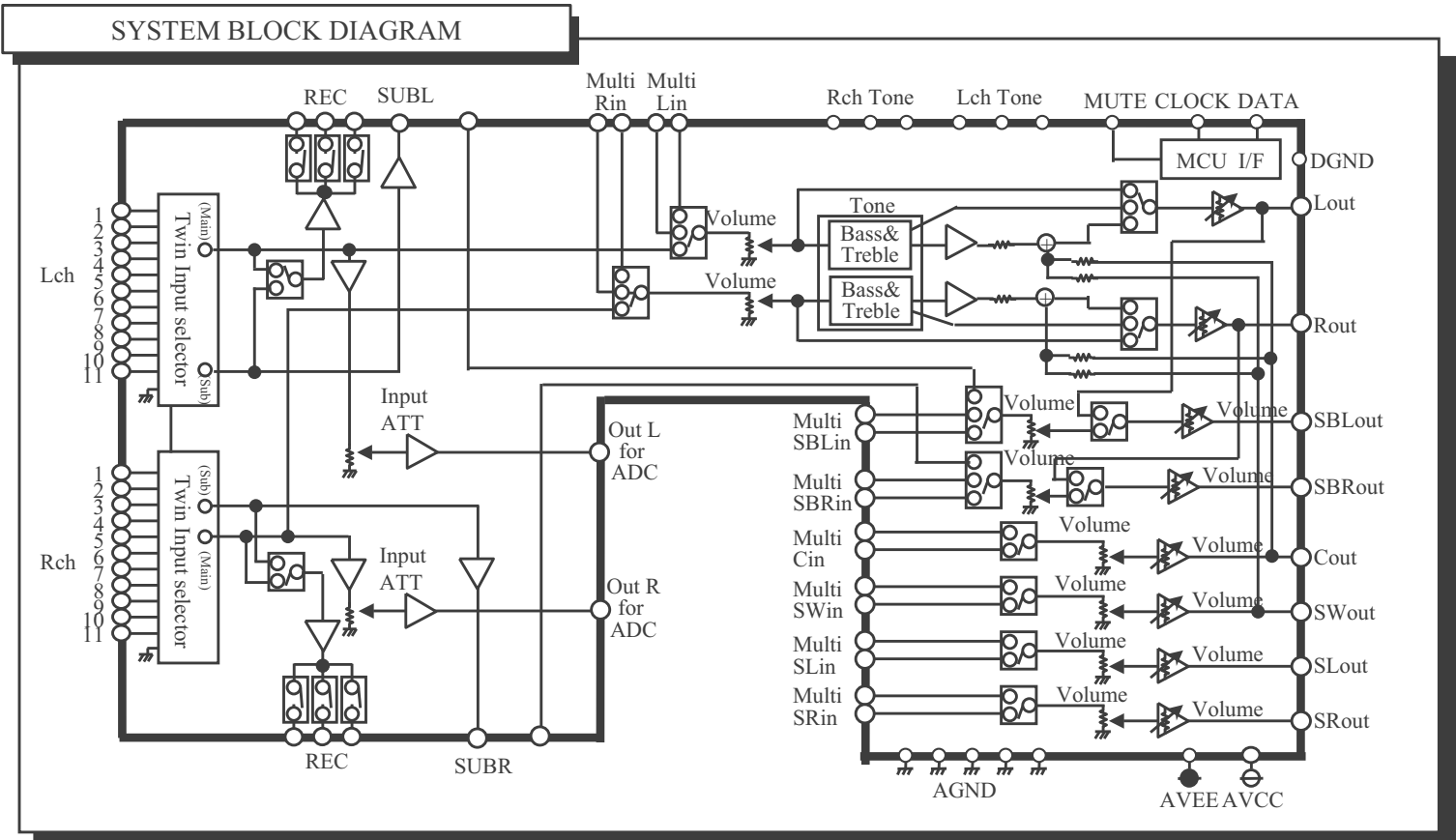

BLOCK DIAGRAM AND PIN CONFIGURATION (TOP VIEW)

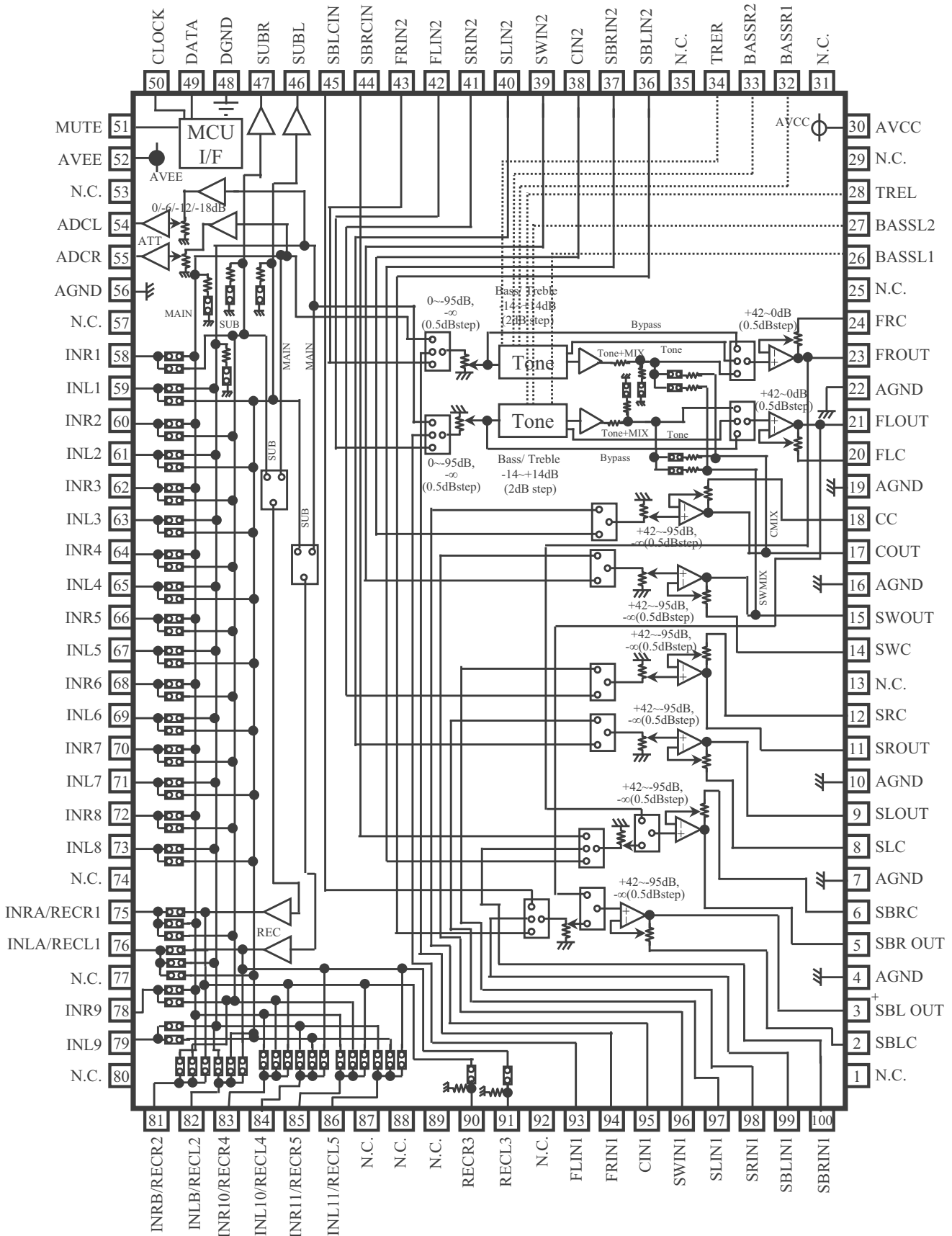

PIN DESCRIPTION

PIN No.	Name	Function
23,21, 17,15, 11,9, 5,3	FROUT,FLOUT, COUT,SWOUT, SROUT, SLOUT, SBROUT,SBLOUT	Output pin of FL/FR/C/SW/SL/SR/SBL/SBR channel
24,20, 18,14, 12,8, 6,2	FRC,FLC, CC,SWC, SRC,SLC, SBRC,SBLC	Connects capacitor for reducing click noise of L/R/C/SW/SL/SR/SBL/SBR channel volume
4,7,10,16, 19,22,56	AGND	Analog ground of internal circuit
28,34	TREL, TRER	Frequency characteristic setting pin of L/R channel tone control (Treble)
26,27, 32,33	BASSL1,BASSL2 BASSR1,BASSR2	Frequency characteristic setting pin of L/R channel tone control (Bass)
30	AVCC	Positive power supply to internal circuit
43,42, 41,40, 39,38, 37,36	FRIN2, FLIN2, SRN2,SLIN2, SWIN2,CIN2, SBRIN2,SBLIN2	Input pin of L/R/C/SW/SL/SR/SBL/SBR channel (Multi IN 1/2)
93,94, 95,96, 97,98, 99,100	FLIN1, FRIN1, CIN1,SWIN1, SLIN1,SRIN1, SBLIN1,SBRIN1	
48	DGND	Digital ground of internal circuit
49	DATA	Input pin of control data
50	CLOCK	Input pin of control clock
52	AVEE	Negative power supply to internal circuit
59,61,63, 65,67,69, 71,73,79	INL1,INL2, INL3, INL4,INL5,INL6, INL7,INL8,INL9	Input pin of L/R channel (Input Selector)
58,60,62, 64,66,68, 70,72,78	INR1,INR2, INR3, INR4,INR5,INR6, INR7,INR8,INR9	
51	MUTE	Outside Mute Control PIN
44,45	SBRCIN,SBLCIN	Input pin for SBL/SBR channel Volume
46,47	SUBL,SUBR	Output pin for L/R channel SUB Output
54,55	ADCL, ADCR	Output pin for L/R channel ADC
90,91	RECR3,RECL3	Output pin for L/R channel REC Output
75,76, 81,82, 83,84, 85,86	INRA/RECR1,INLA/RECL1, INRB/RECR2,INLB/RECL2, INR10/RECR4,INL10/RECL4, INR11/RECR5,INL11/RECL5	Input pin of L/R channel (Input Selector)/ Output pin for L/R channel REC Output
1,13,25,29,31, 35,53, 57,74,77,80, 87,88,89,92	N.C.	No Connected PIN

IC173: SII9134CUT: HDMI TRANSMITTER

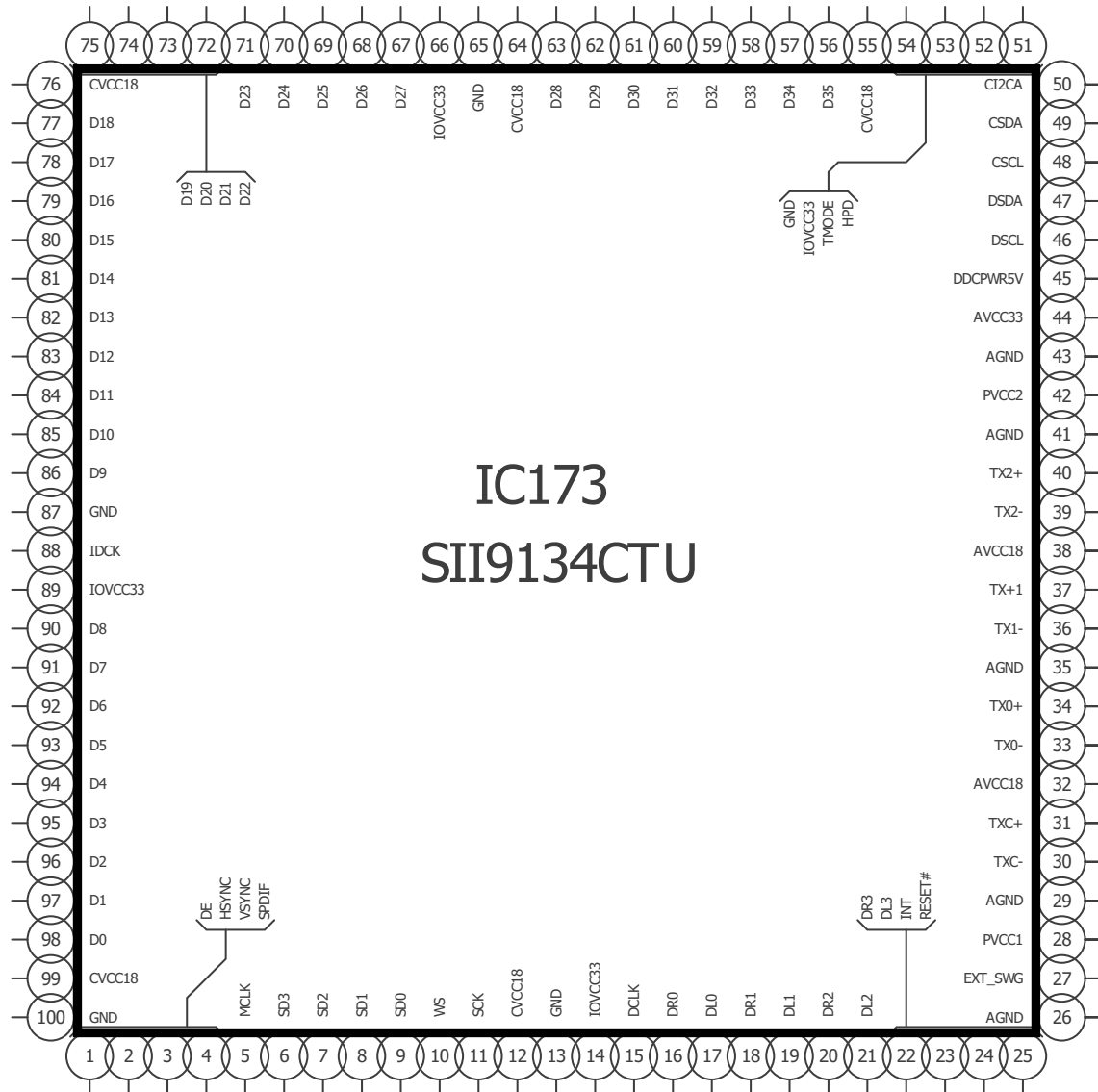

BLOCK DIAGRAM

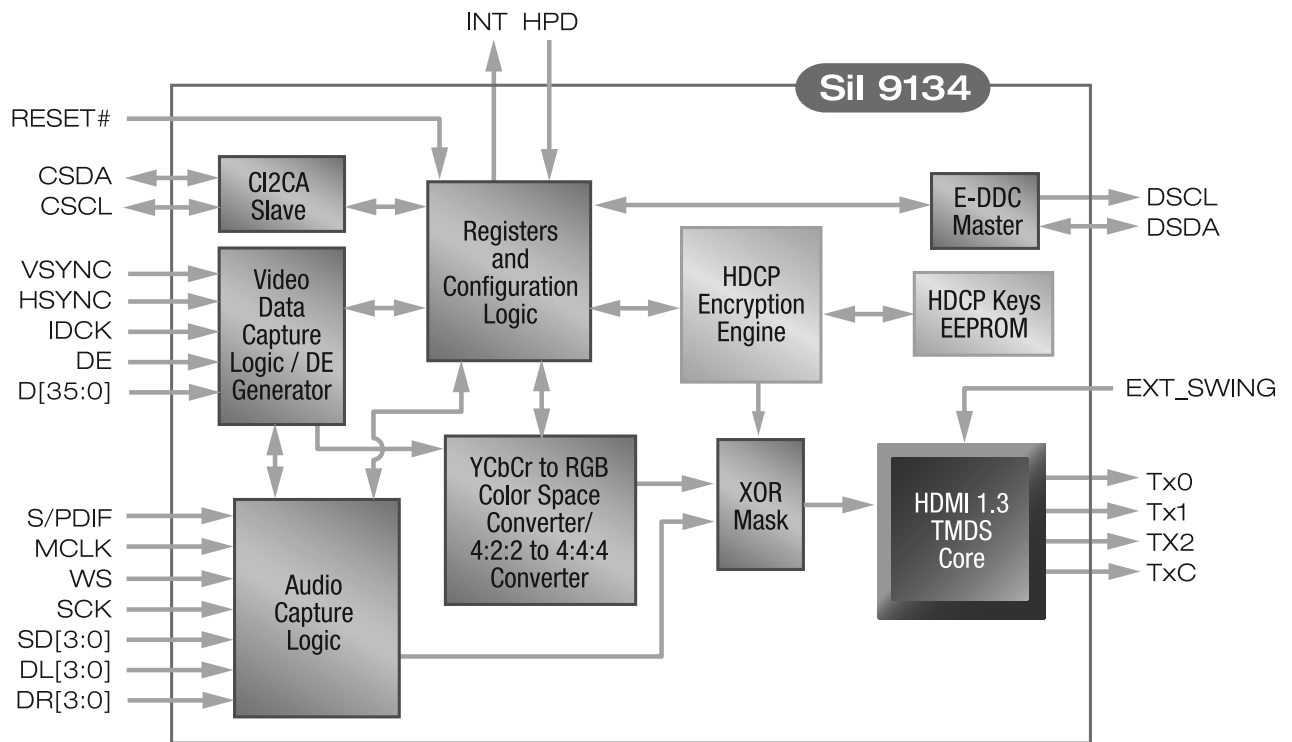

IC146: SII9135CTU: HDIM RECEIVER

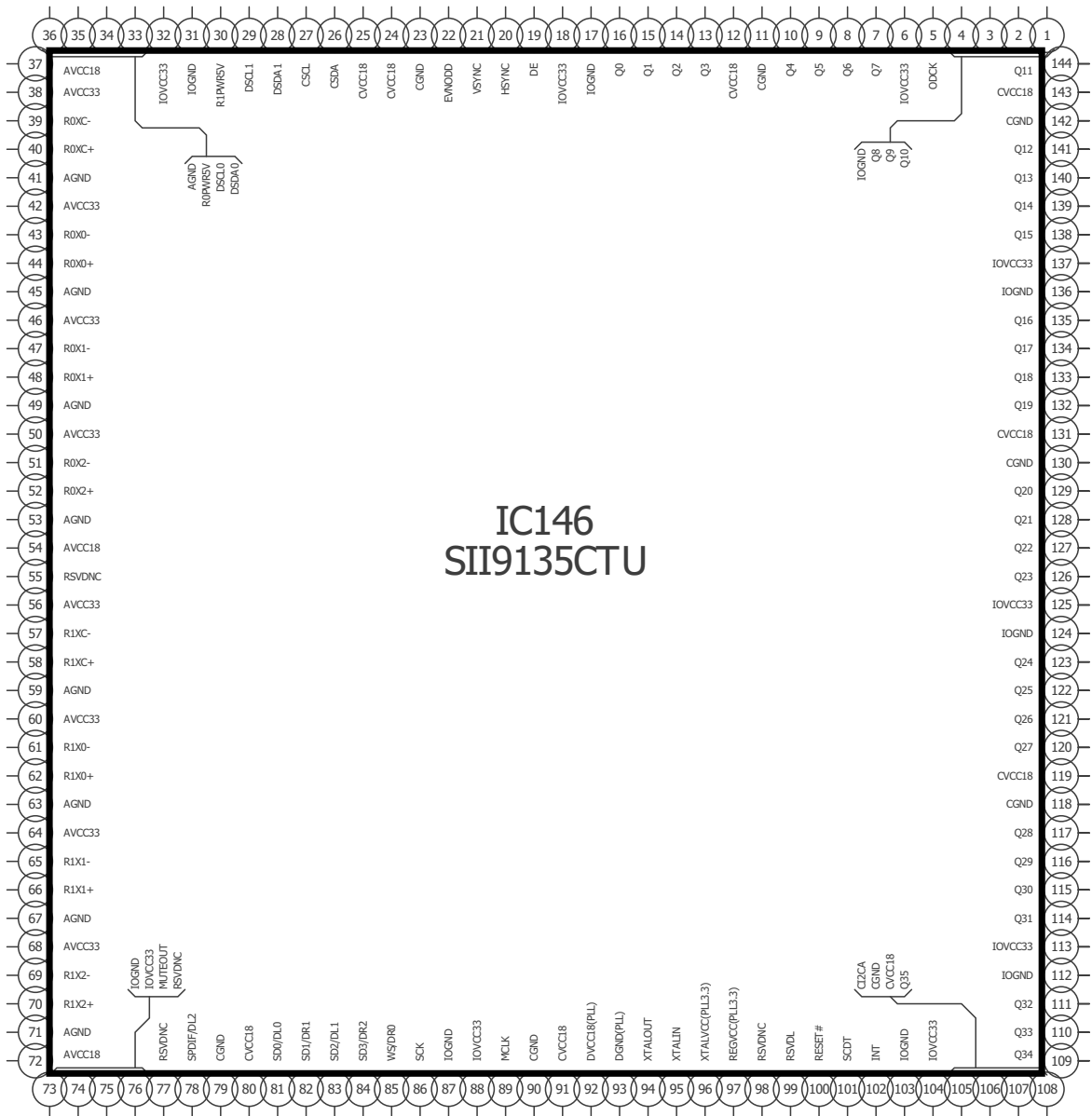

BLOCK DIAGRAM

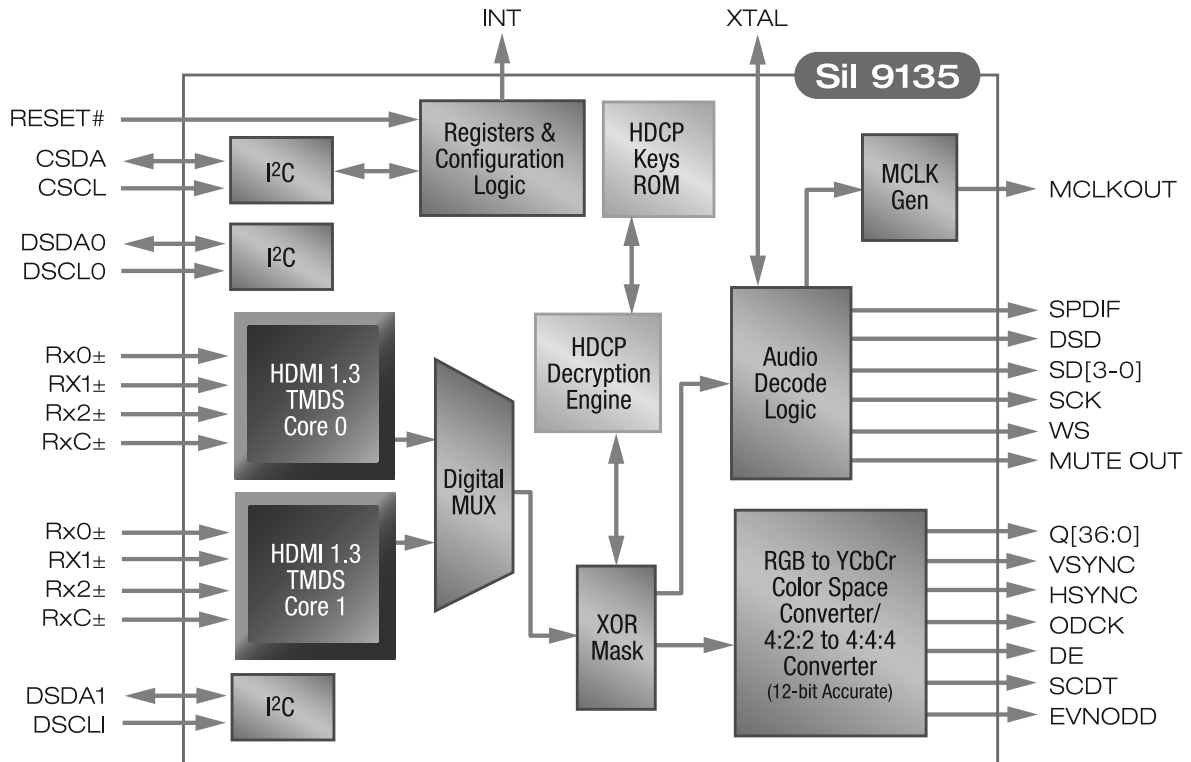

IC141: SII9185ACTU: HDMI SWITCH

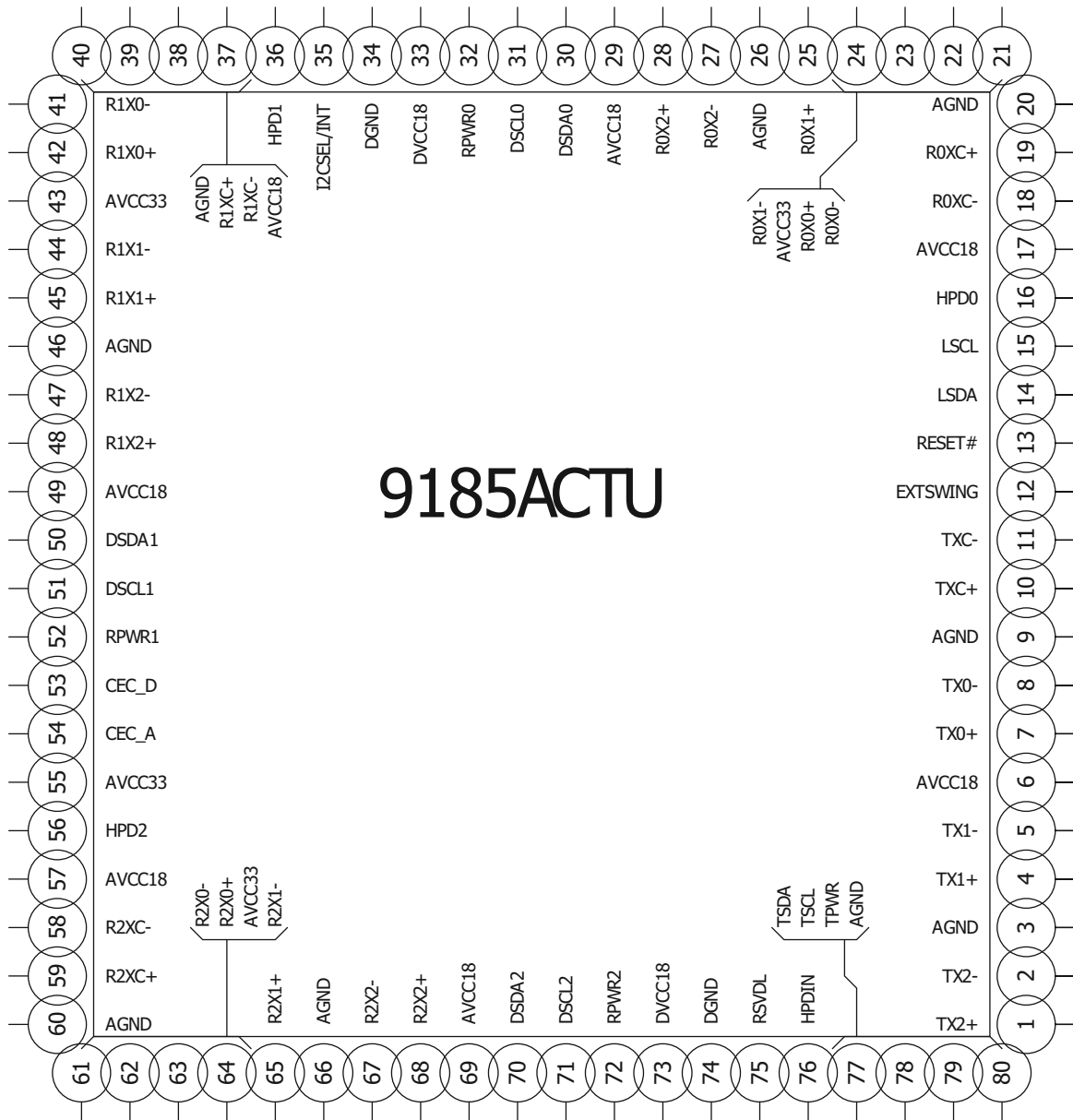

BLOCK DIAGRAM

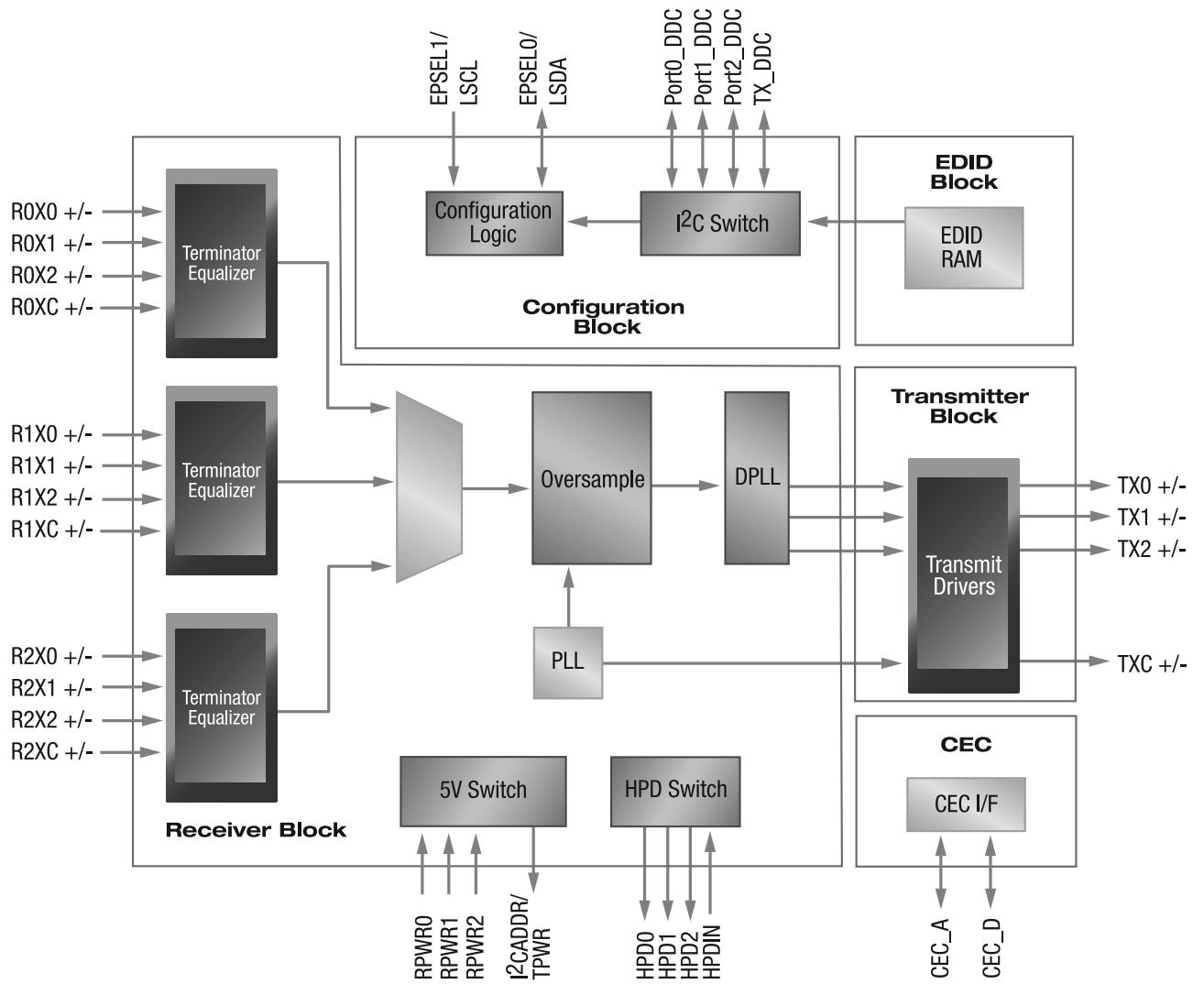

IC157: ST232CDR: RS-232 DRIVERS & RECEIVERS

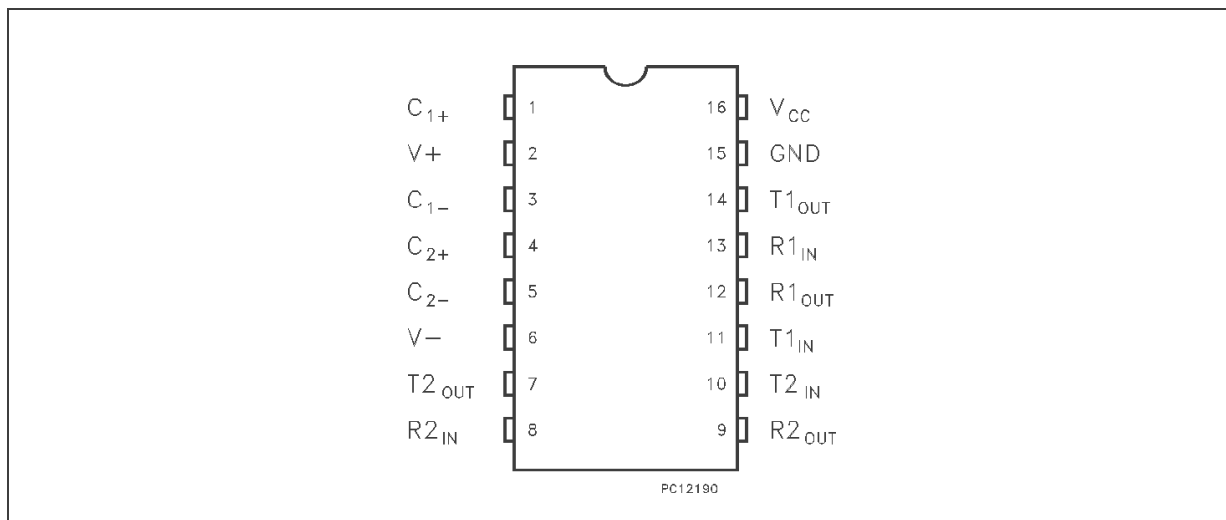

PIN N°	SYMBOL	NOTE
1	C_{1+}	Positive terminal for the first charge pump capacitor
2	$V+$	Doubled voltage terminal
3	C_{1-}	Negative terminal for the first charge pump capacitor
4	C_{2+}	Positive terminal for the second charge pump capacitor
5	C_{2-}	Negative terminal for the second charge pump capacitor
6	$V-$	Inverted voltage terminal
7	$T2_{OUT}$	Second transmitter output voltage
8	$R2_{IN}$	Second receiver input voltage
9	$R2_{OUT}$	Second receiver output voltage
10	$T2_{IN}$	Second transmitter input voltage
11	$T1_{IN}$	First transmitter input voltage
12	$R1_{OUT}$	First receiver output voltage
13	$R1_{IN}$	First receiver input voltage
14	$T1_{OUT}$	First transmitter output voltage
15	GND	Ground
16	V_{CC}	Supply voltage

IC147: TC74VCX541FT: OCTAL BUS BUFFER

PIN ASSIGNMENT

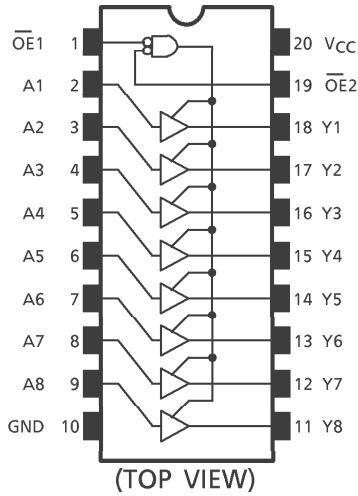

IEC LOGIC SYMBOL

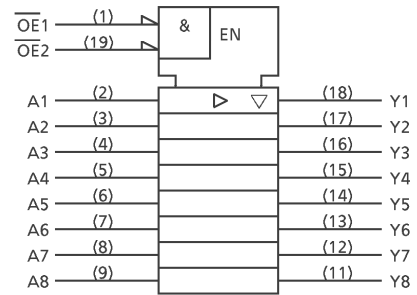

TRUTH TABLE

INPUTS			OUTPUTS
OE1	OE2	An	
H	X	X	Z
X	H	X	Z
L	L	H	H
L	L	L	L

X : Don't Care
Z : High Impedance

MAXIMUM RATINGS

PARAMETER	SYMBOL	RATING	UNIT
Power Supply Voltage	V_{CC}	-0.5~4.6	V
DC Input Voltage	V_{IN}	-0.5~4.6	V
DC Output Voltage	V_{OUT}	-0.5~4.6 (Note 1)	V
		-0.5~ $V_{CC} + 0.5$ (Note 2)	
Input Diode Current	I_{IK}	-50	mA
Output Diode Current	I_{OK}	±50 (Note 3)	mA
DC Output Current	I_{OUT}	±50	mA
Power Dissipation	P_D	180	mW
DC V_{CC} / Ground Current	I_{CC} / I_{GND}	±100	mA
Storage Temperature	T_{stg}	-65~150	°C

(Note 1): Off-State

(Note 2): High or Low State. I_{OUT} absolute maximum rating must be observed.

(Note 3): $V_{OUT} < GND$, $V_{OUT} > V_{CC}$

IC156: M24C32WMN6TP: EEPROM

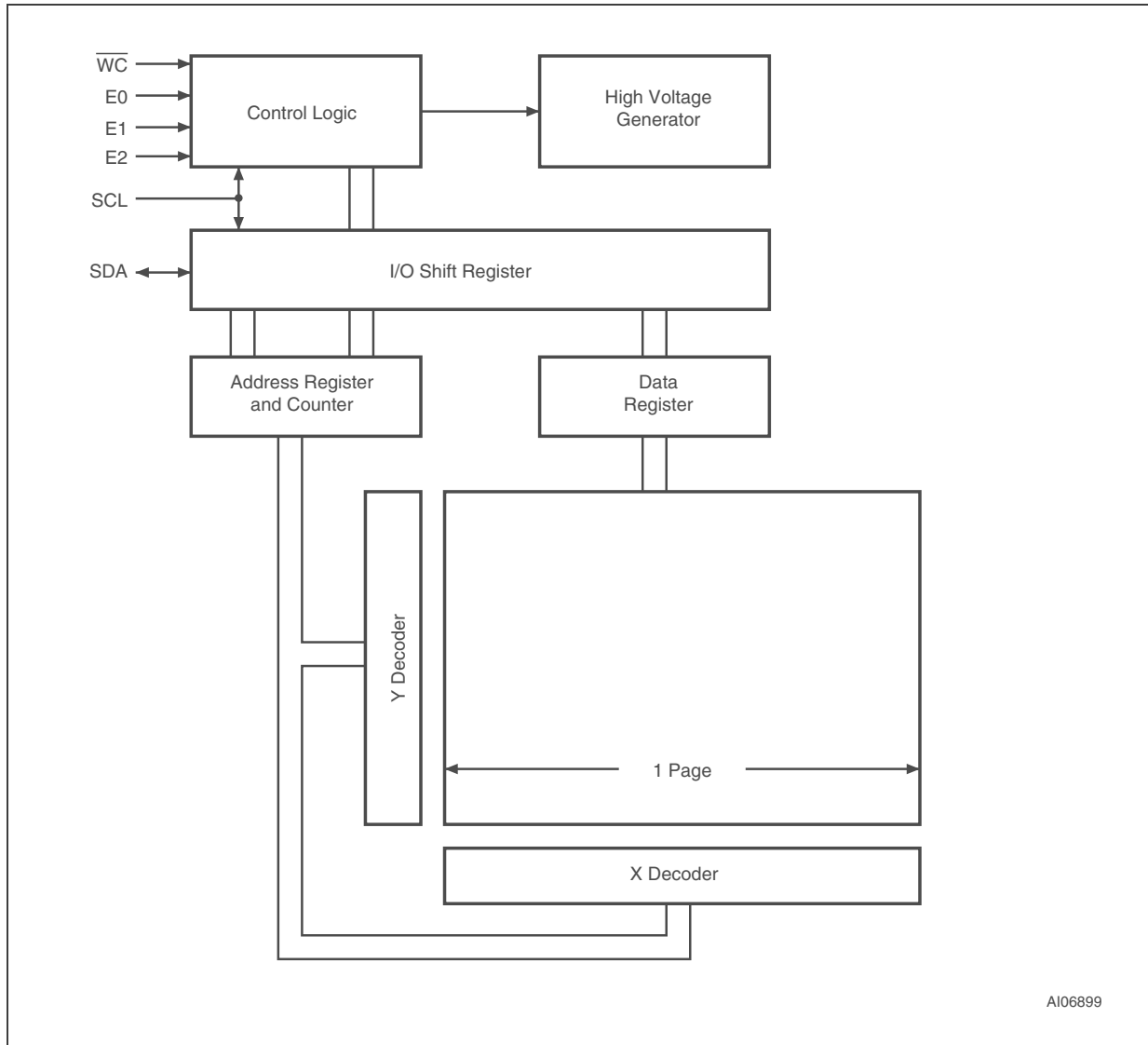

AI06899

TRANSISTOR, REGULATOR IC BLOCK DIAGRAM

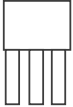
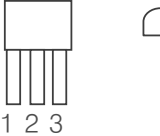
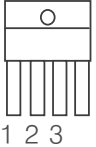
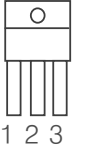
<p>TO-92S</p>  <p>1 2 3</p> <p>KSC2785Y KRC107M KSA1175Y KTC2875Y KRC111M KSB811Y</p>	<p>TO-92</p>  <p>1 2 3</p> <p>KTC3200GR KTA1271Y KTA1268GR KTC3199Y KTC3203Y</p>	<p>TO-220</p>  <p>1 2 3</p> <p>KIA378R00 1.INPUT KIA278R12 2.OUTPUT 3.GND 4.CONTROL KIA578R05</p>	<p>TO-220</p>  <p>1 2 3</p> <p>KIA78DL05 1.Base KIA7905 2.Collector KIA278R05 3.Emitter KIA7909 KIA7809</p>
--	---	--	--

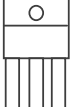
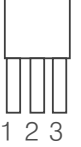
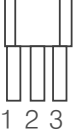
<p>SOT-23</p>  <p>1 2 3</p> <p>KRA102S 1.Base KRC102S 2.Collector KTD1304 3.Emitter</p> <p>KRC107S KRC103S KRC111S</p>	<p>TO-3P</p>  <p>1 2 3</p> <p>2SB1647 1.Base 2SD2560 2.Collector 3.Emitter</p>	<p>TO-92L</p>  <p>1 2 3</p> <p>KSC2316Y 1. Emitter KTD1028B 2. Collector 3. Base</p>
--	---	---

BLOCK DIAGRAM (AUDIO PART)

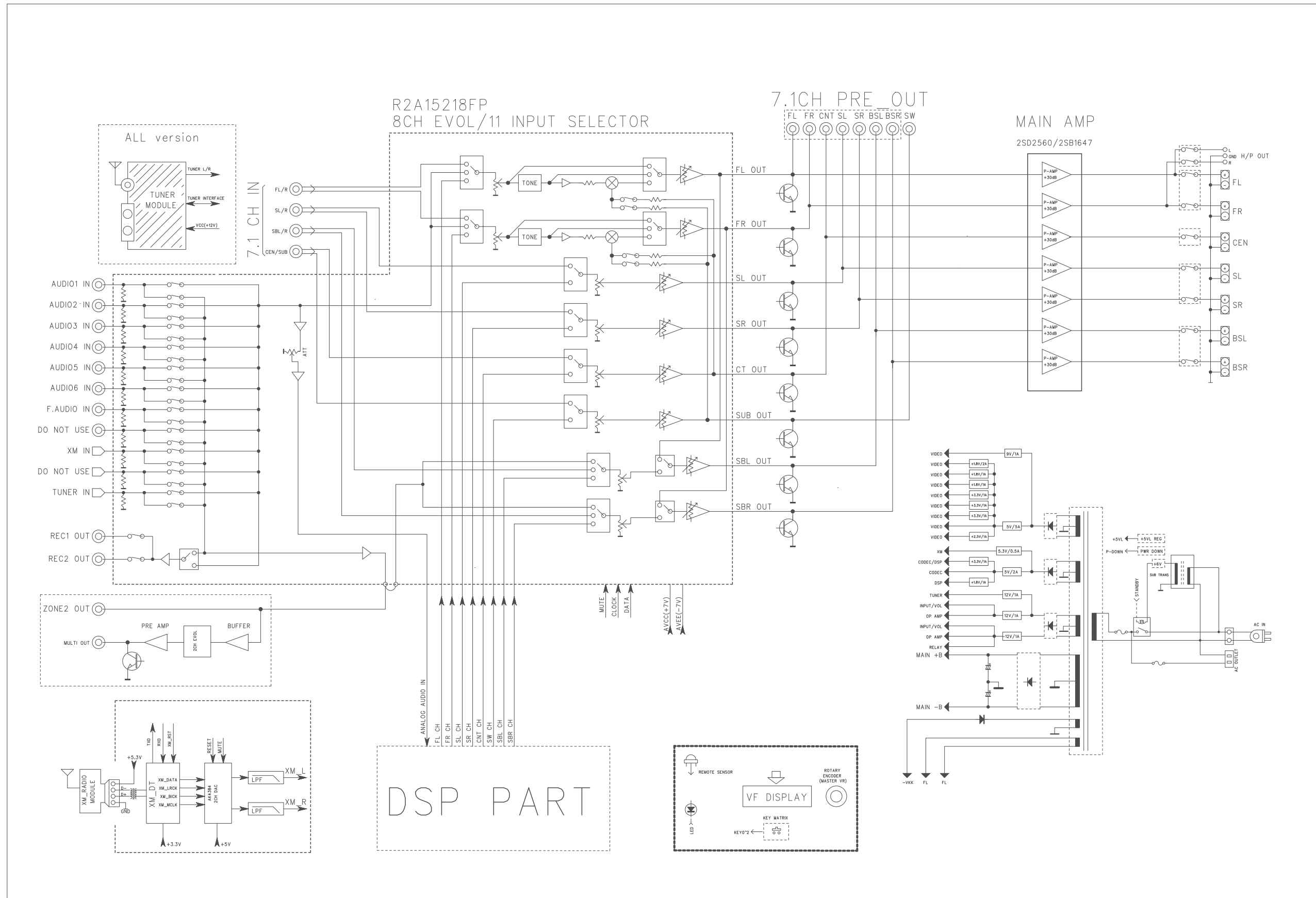

BLOCK DIAGRAM (MCU & DSP PART)

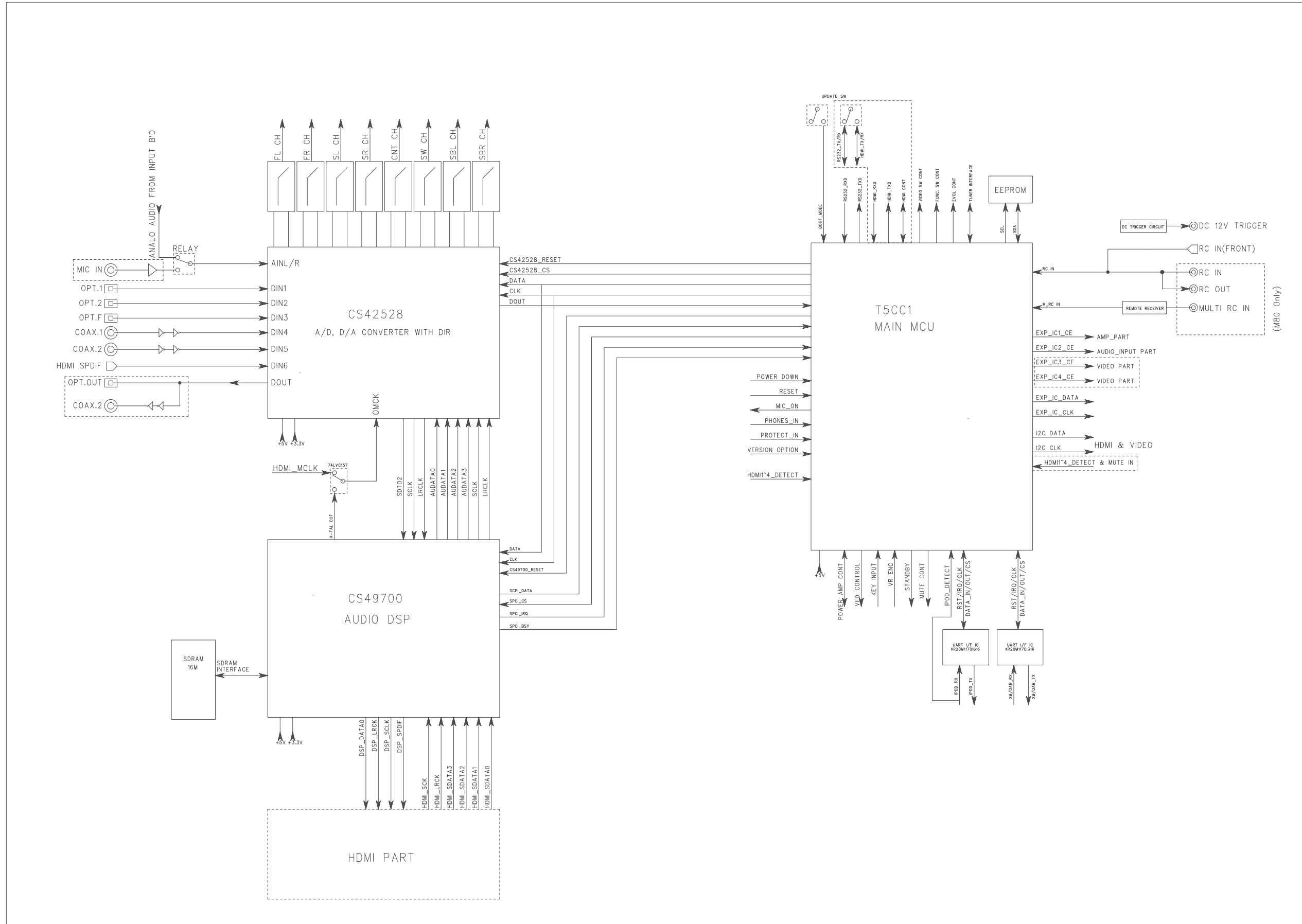

BLOCK DIAGRAM (HDMI PART)

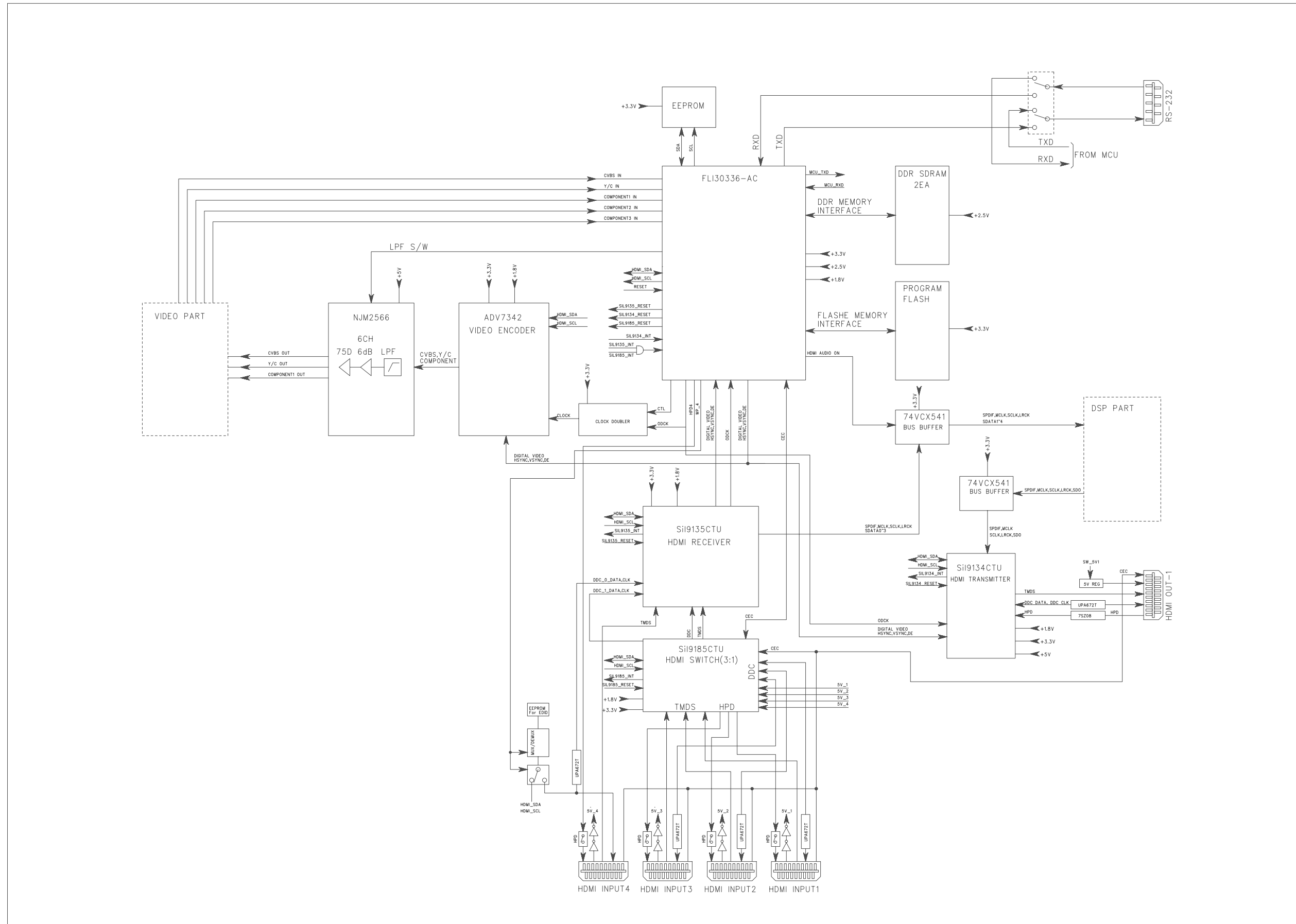

BLOCK DIAGRAM (VIDEO PART)

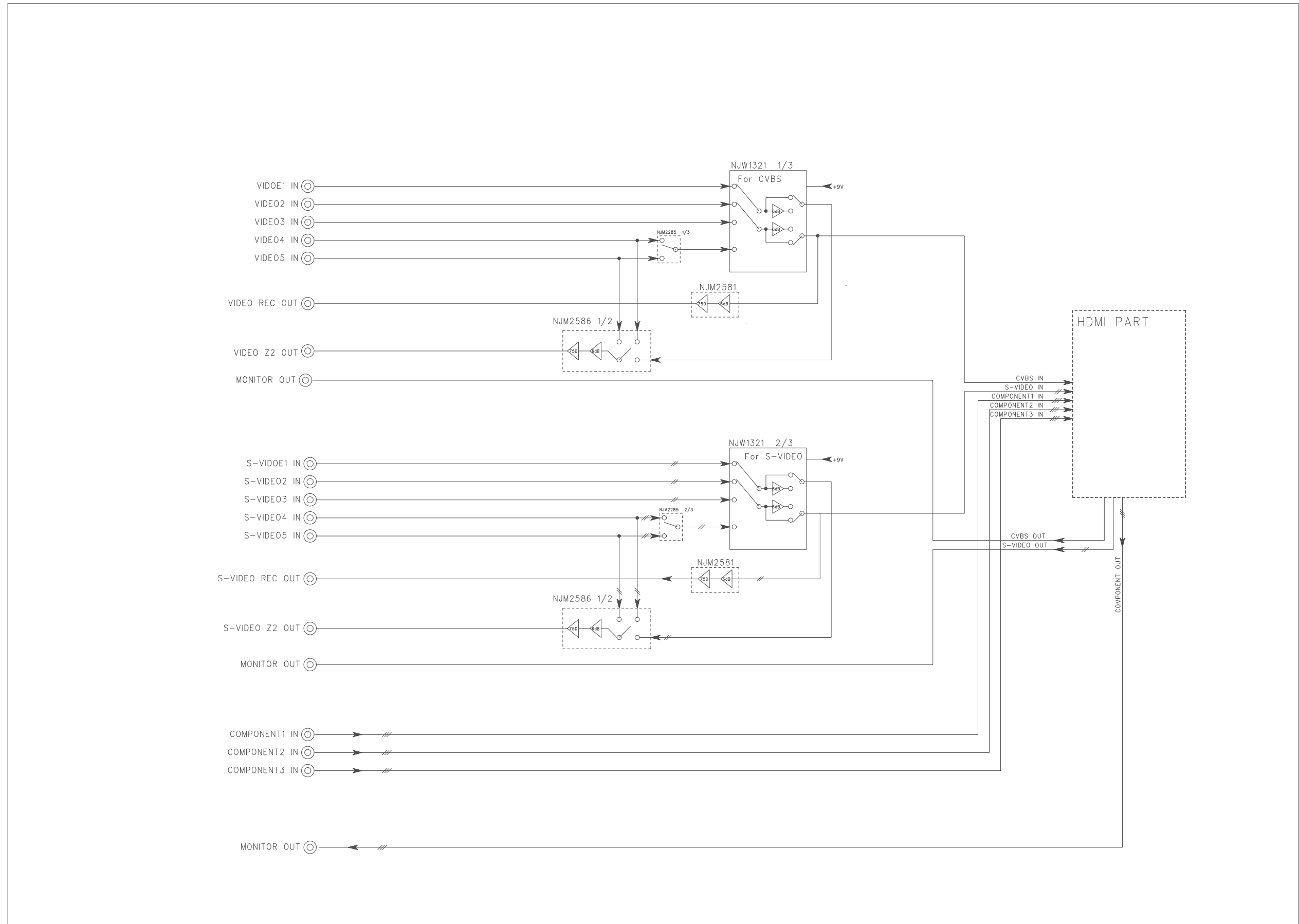

WIRING DIAGRAM

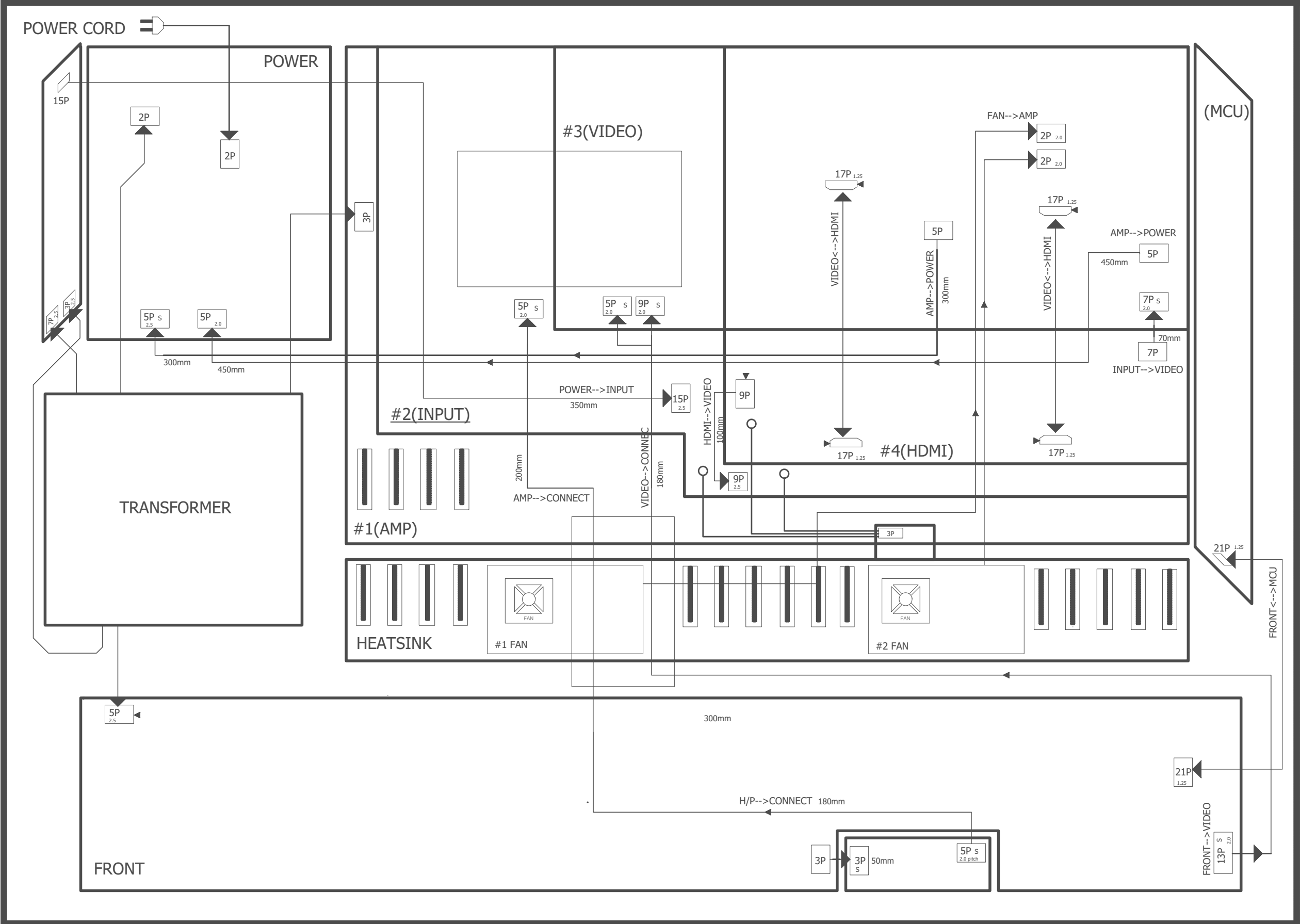

SCHEMATIC DIAGRAM (FRONT PART)

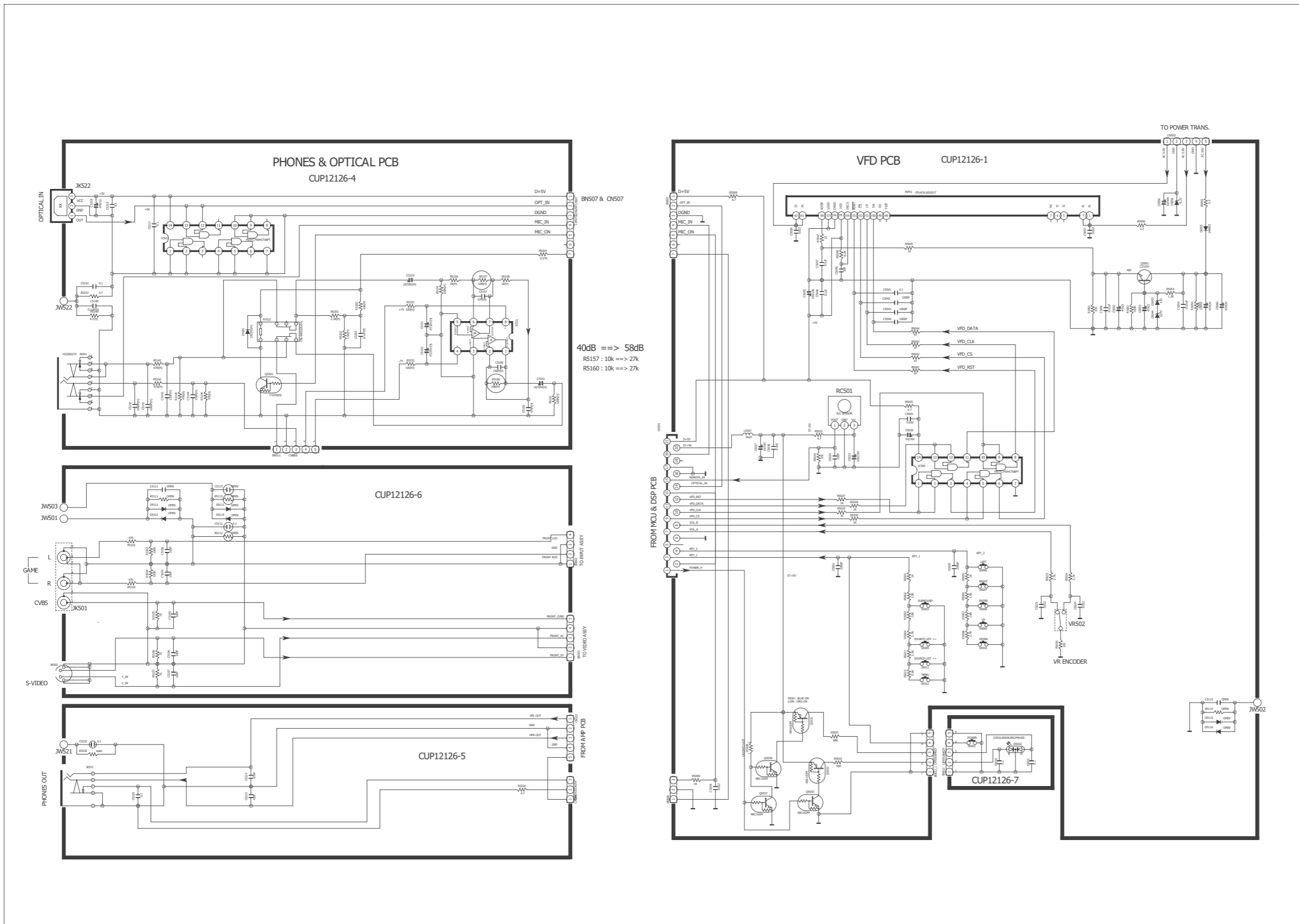

SCHEMATIC DIAGRAM (POWER PART)

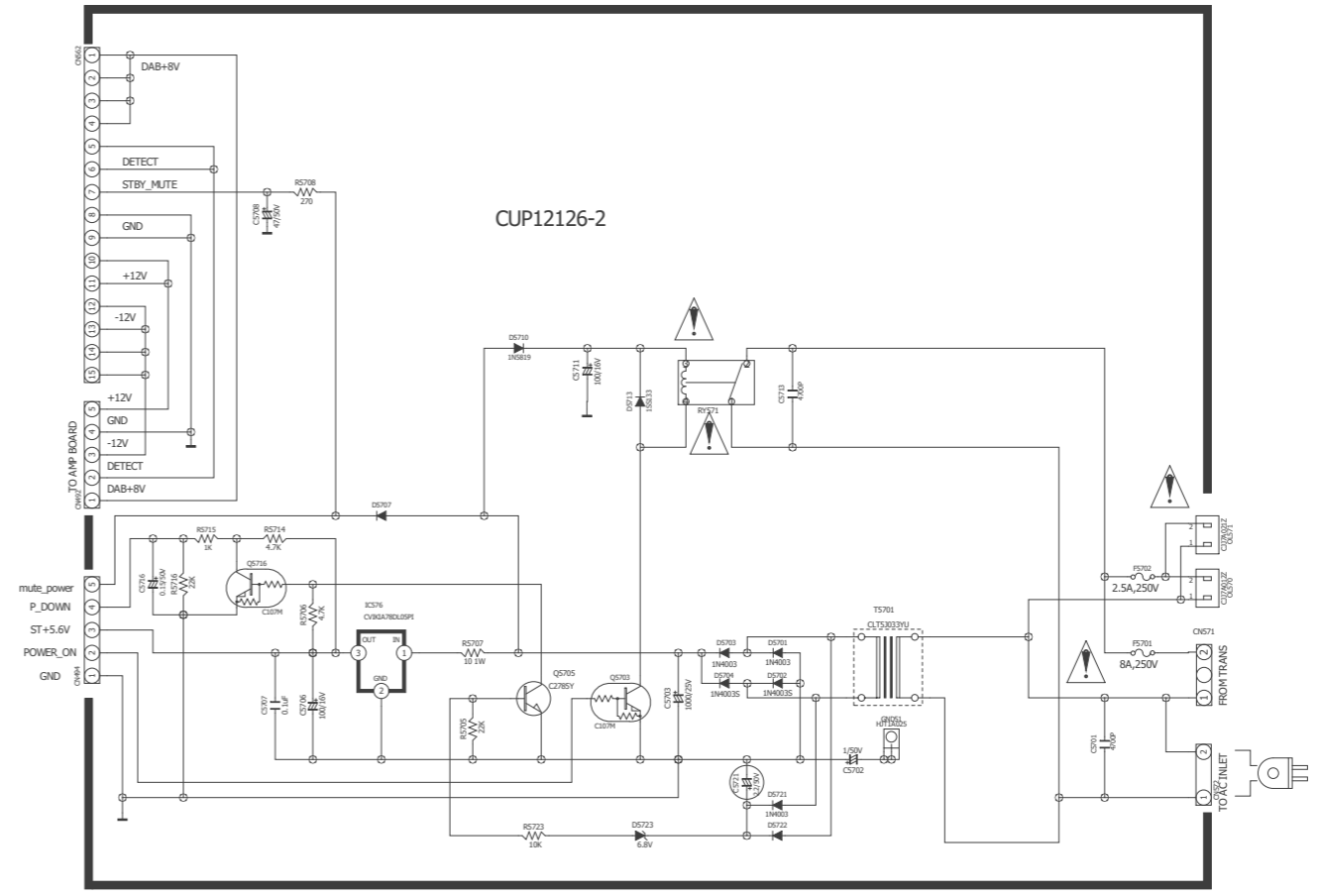
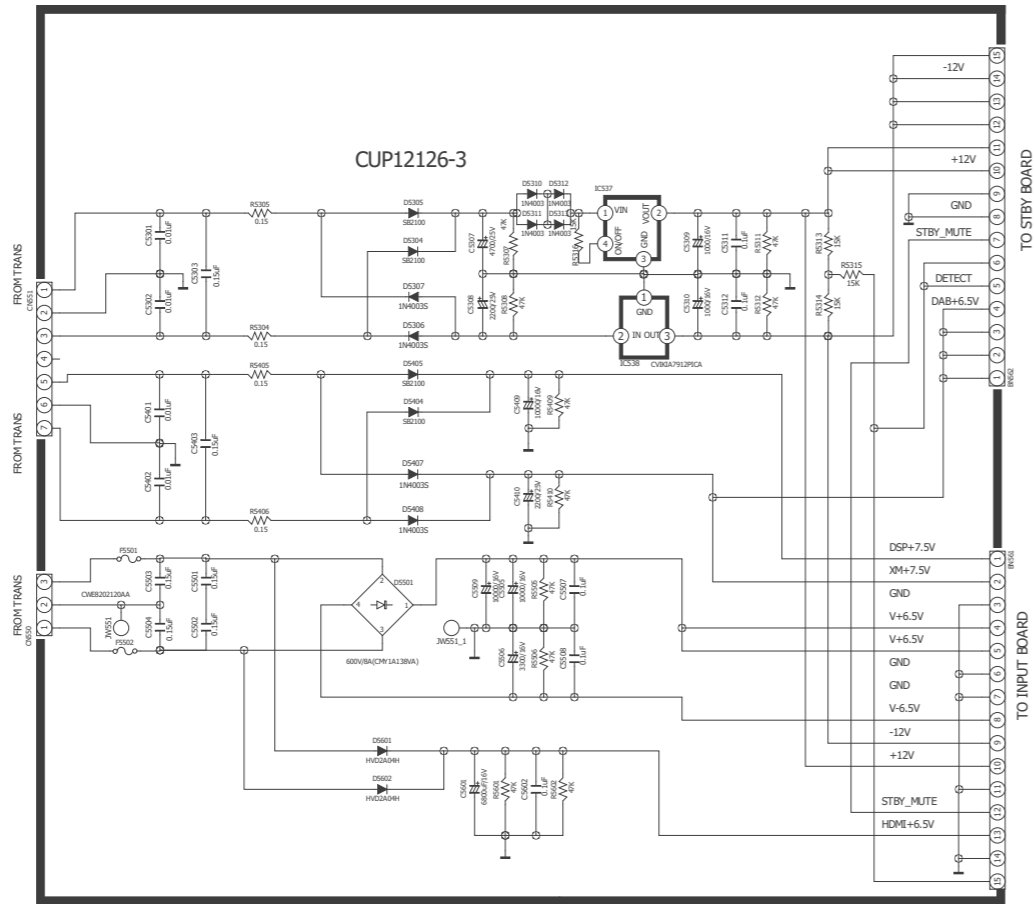

SCHEMATIC DIAGRAM (MCU PART)

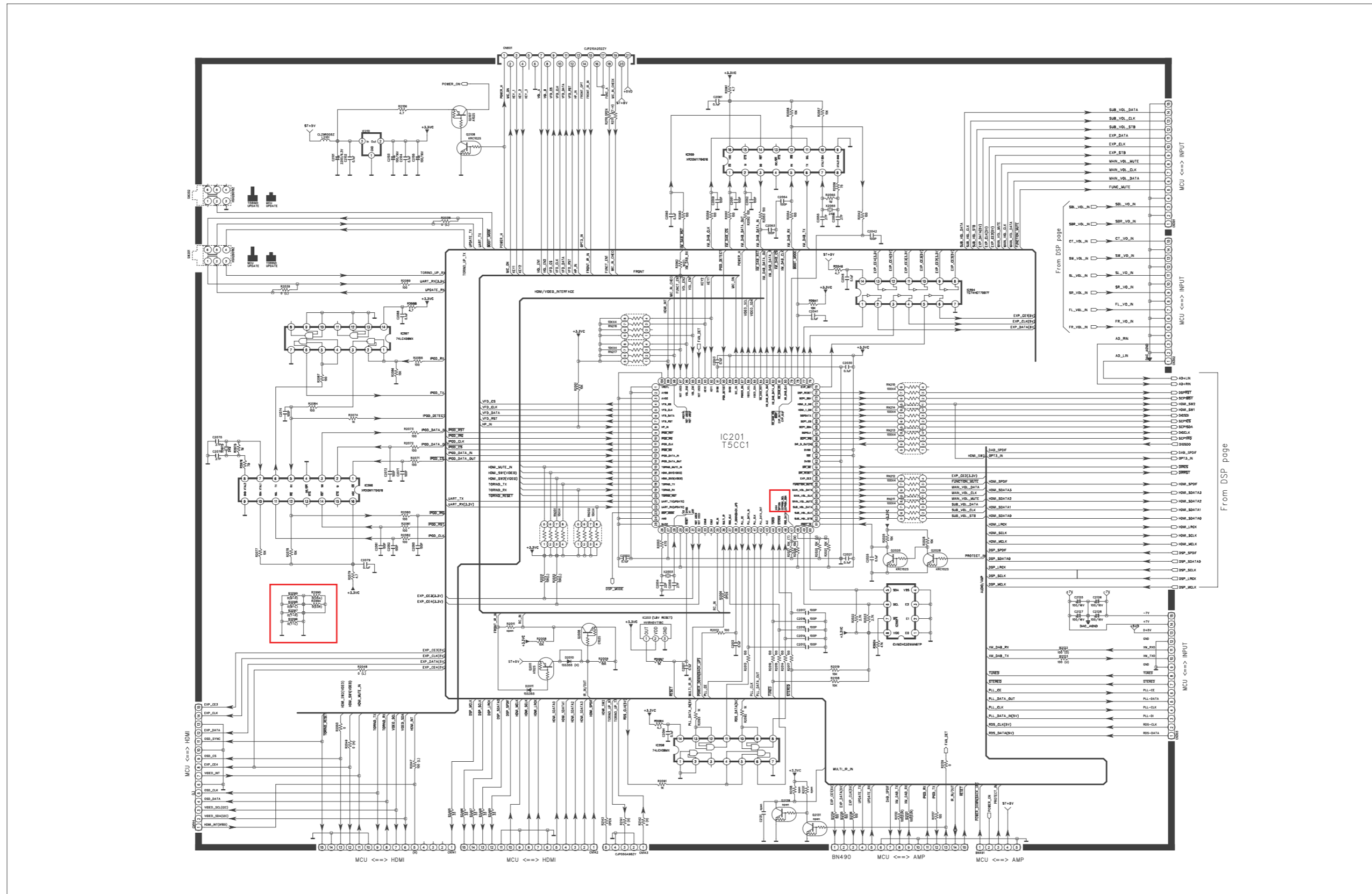

SCHEMATIC DIAGRAM (DSP&CODEC WITH DIR PART)

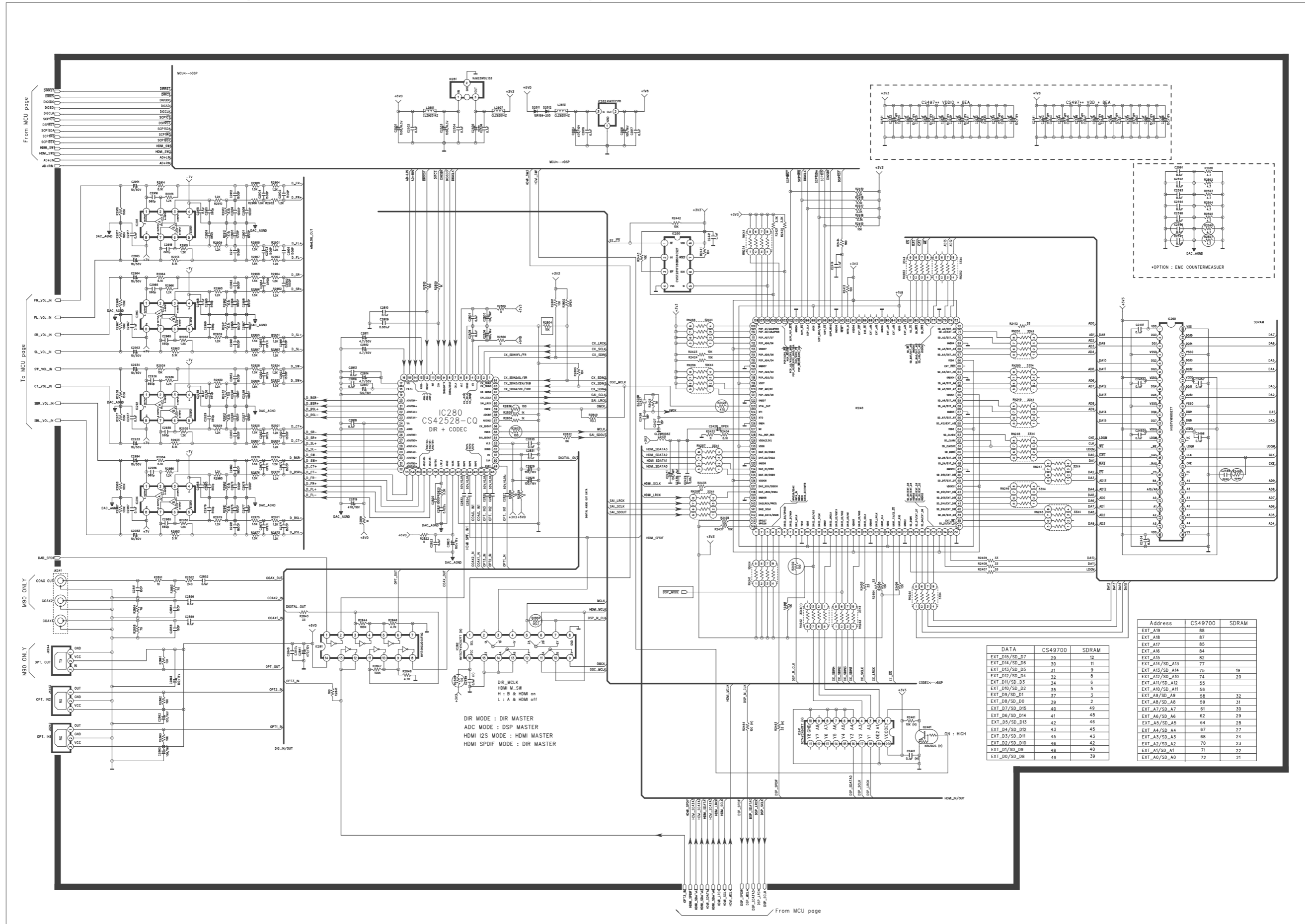

SCHEMATIC DIAGRAM (INPUT&VOLUME PART)

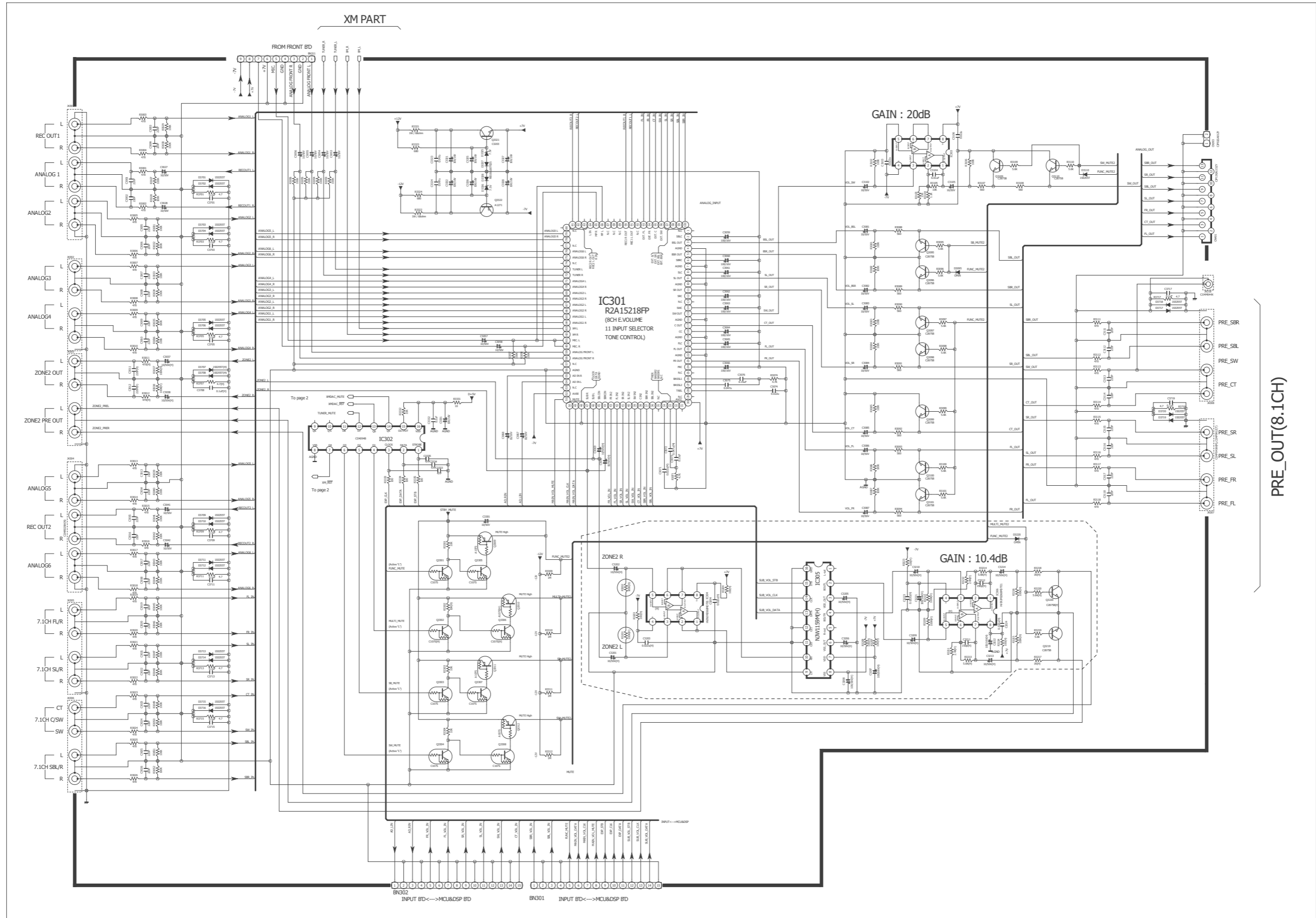

SCHEMATIC DIAGRAM (XM&TUNER PART)

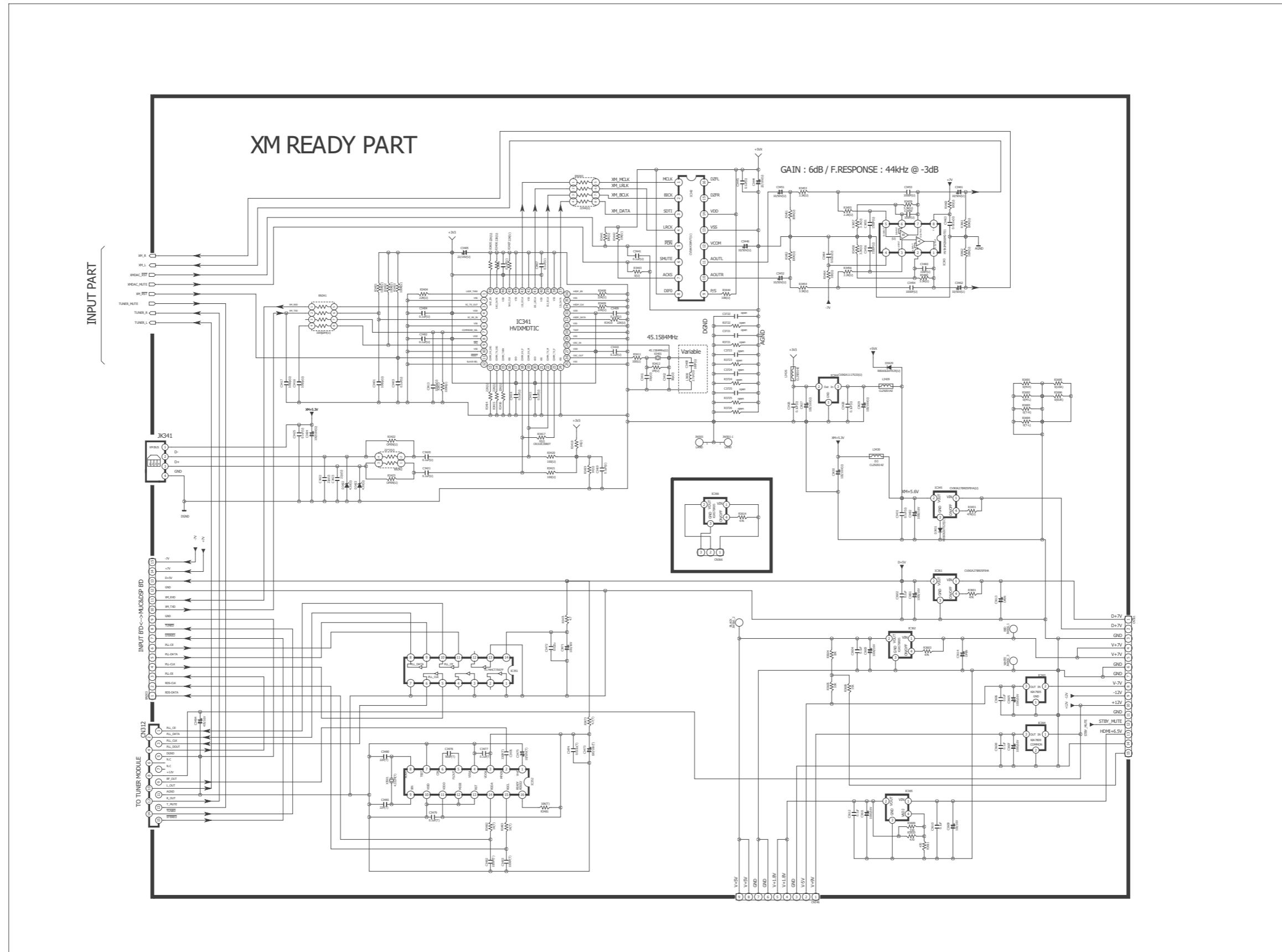

SCHEMATIC DIAGRAM (VIDEO PART)

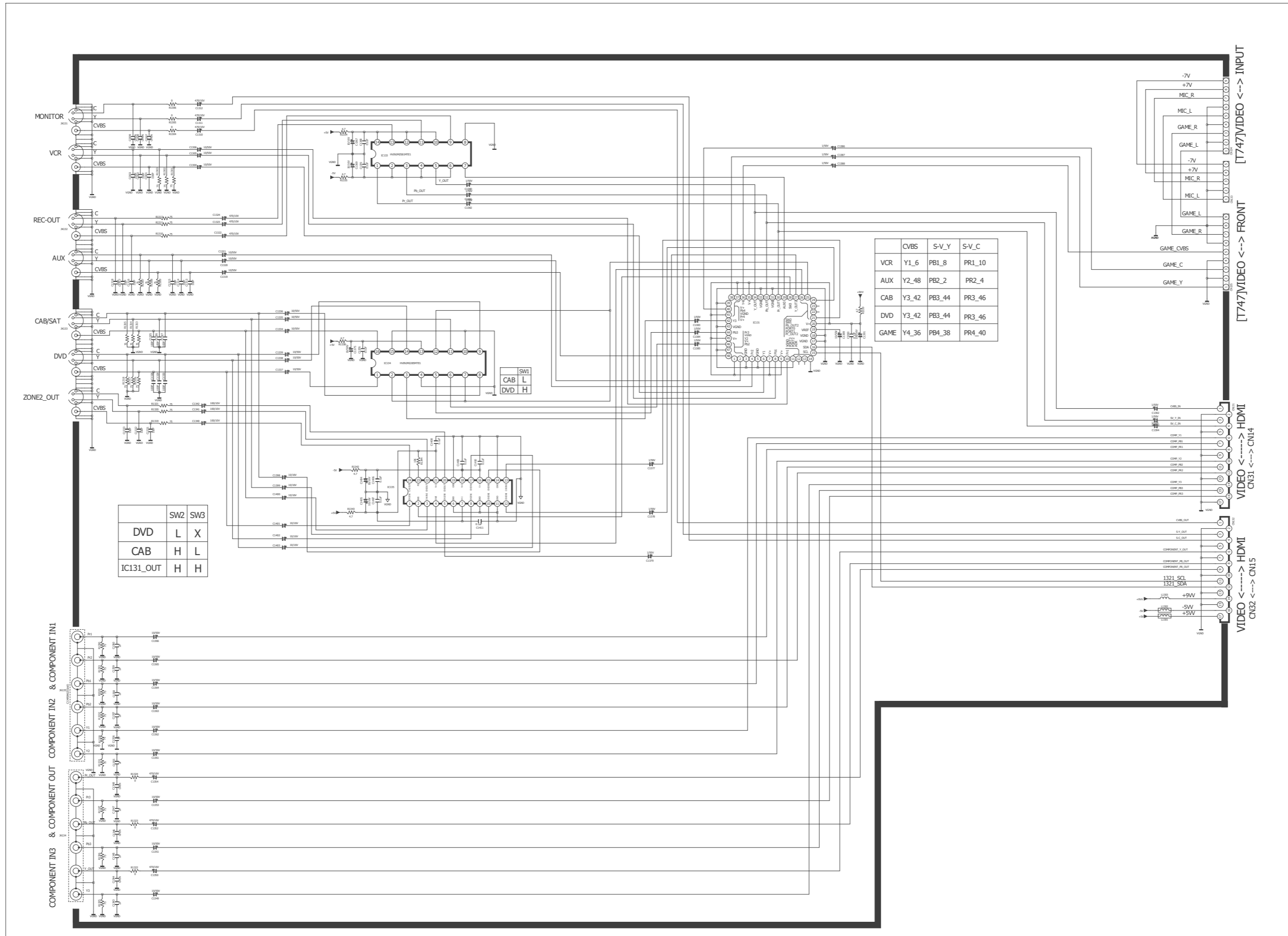

SCHEMATIC DIAGRAM (HDMI #1 PART)

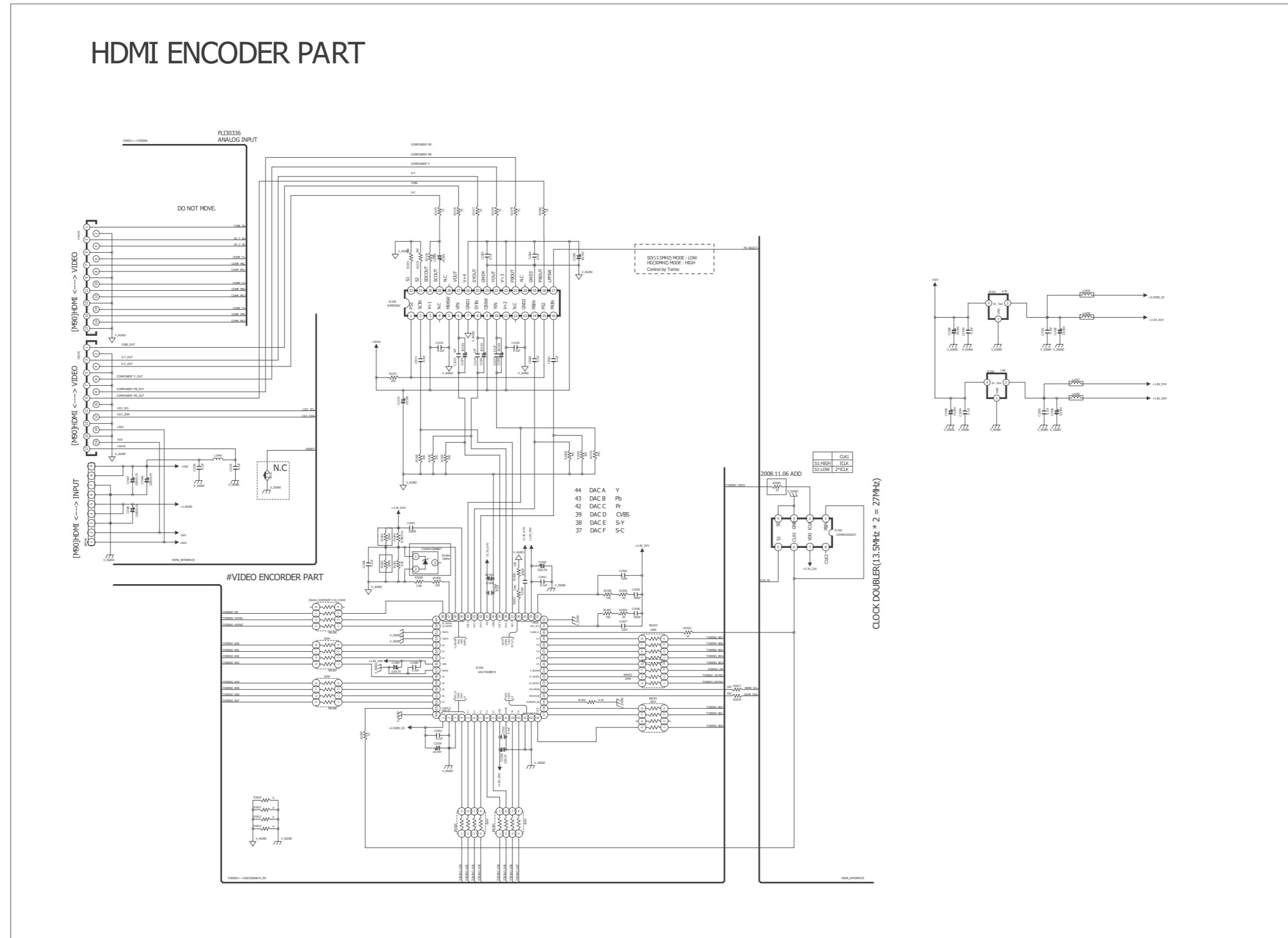

SCHEMATIC DIAGRAM (HDMI #2 PART)

HDMI RX & TX PART



SCHEMATIC DIAGRAM (HDMI #3 PART)

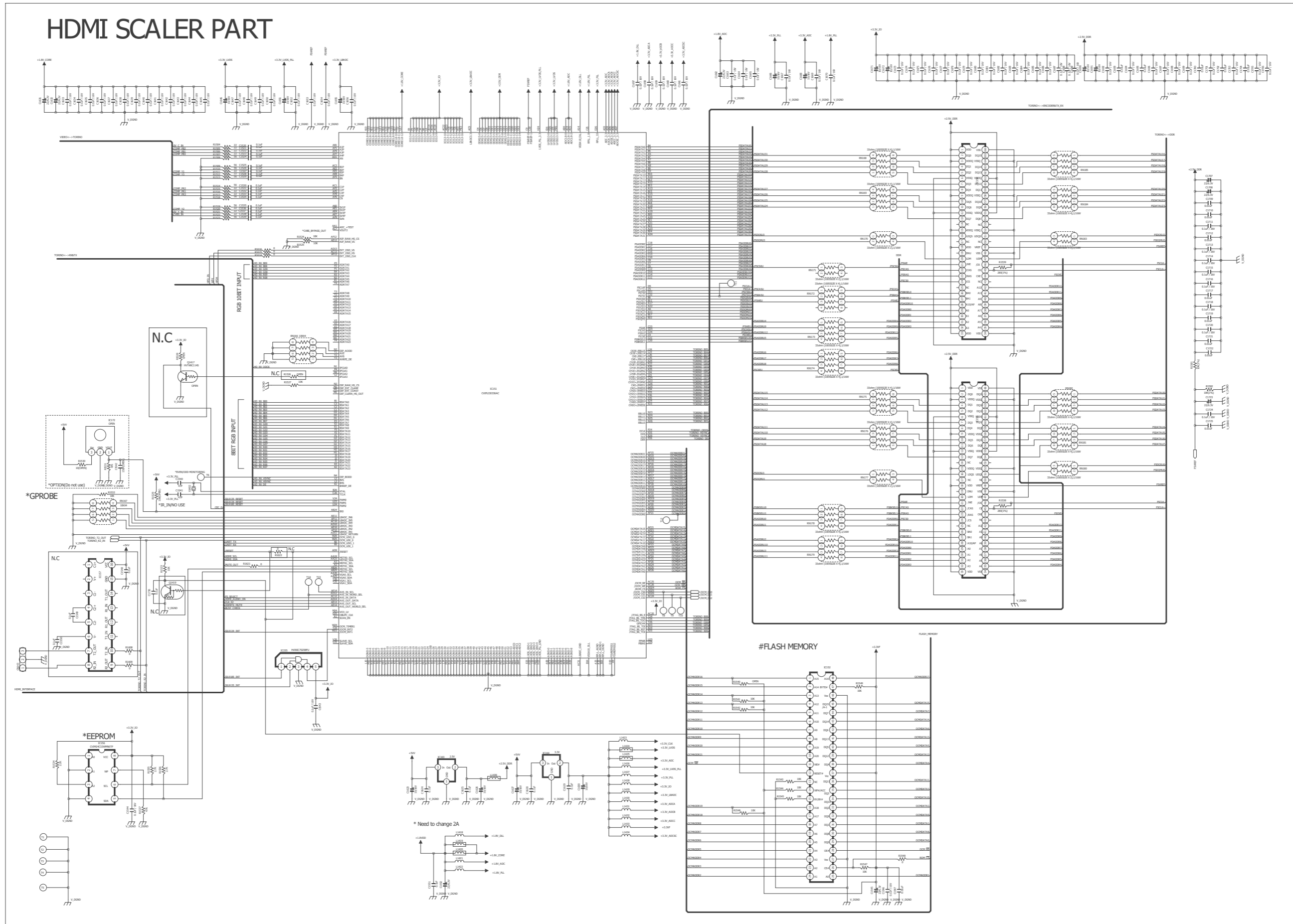

SCHEMATIC DIAGRAM (HDMI #4 PART)

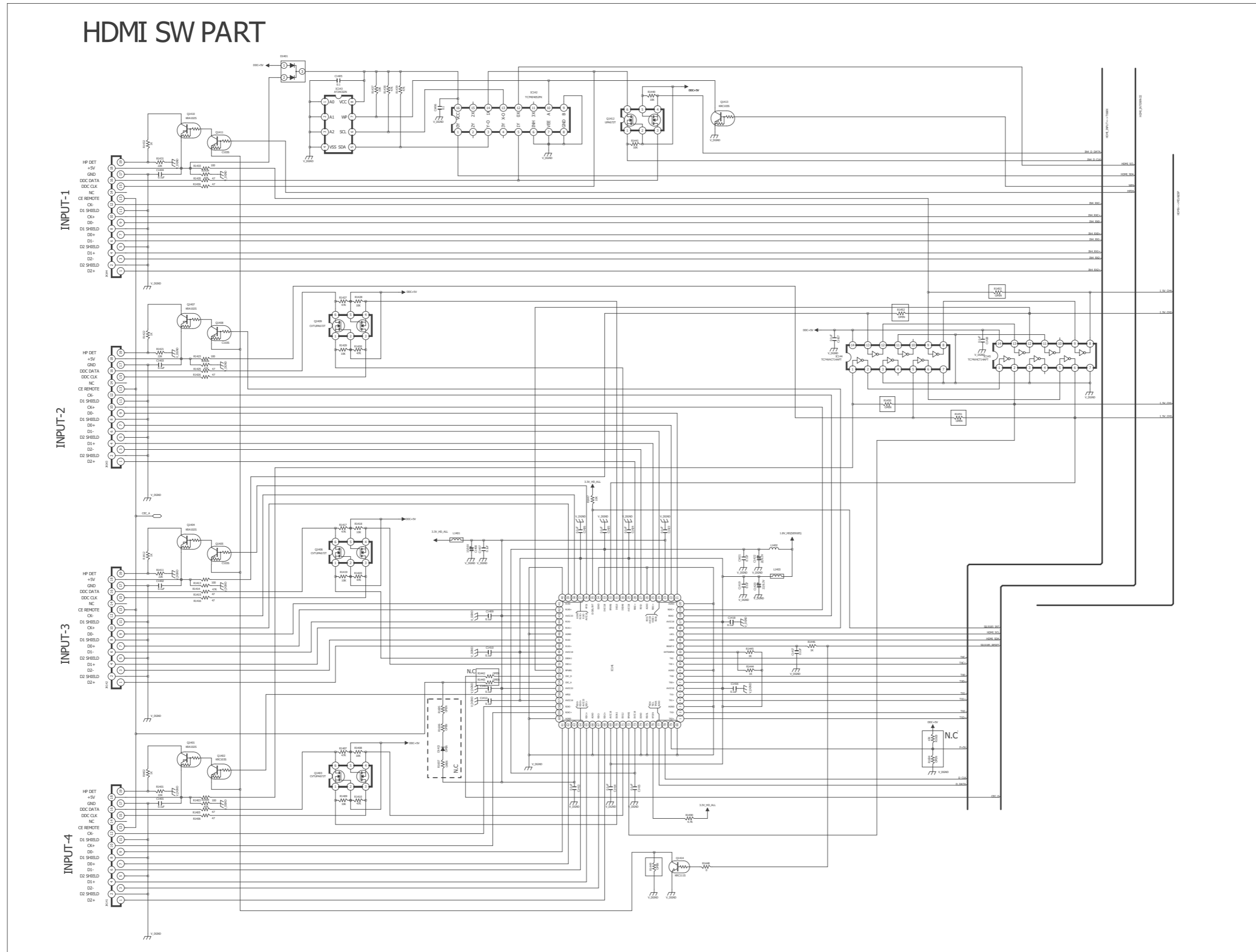

SCHEMATIC DIAGRAM (AMP #1 PART)

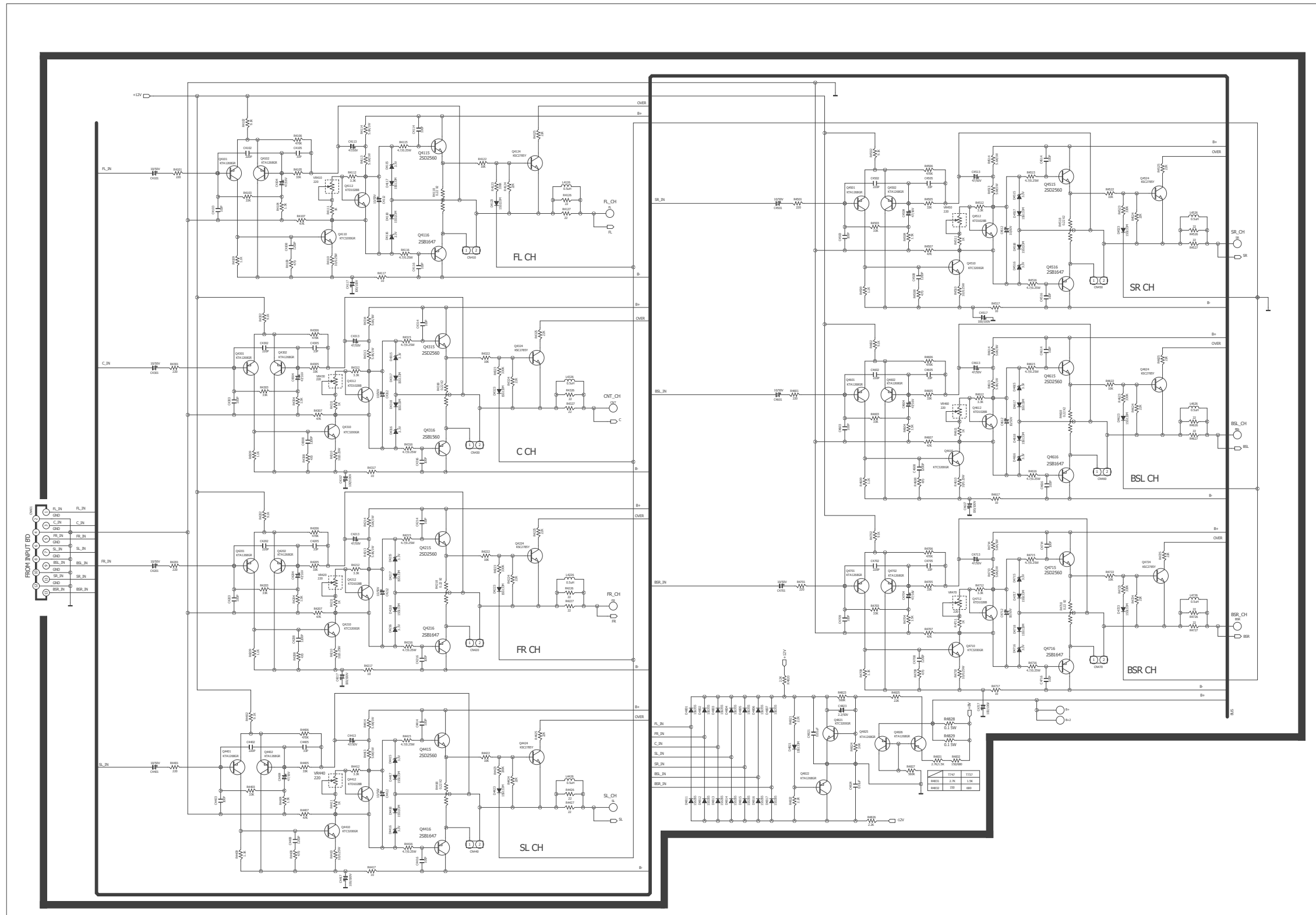

SCHEMATIC DIAGRAM (AMP #2 PART)

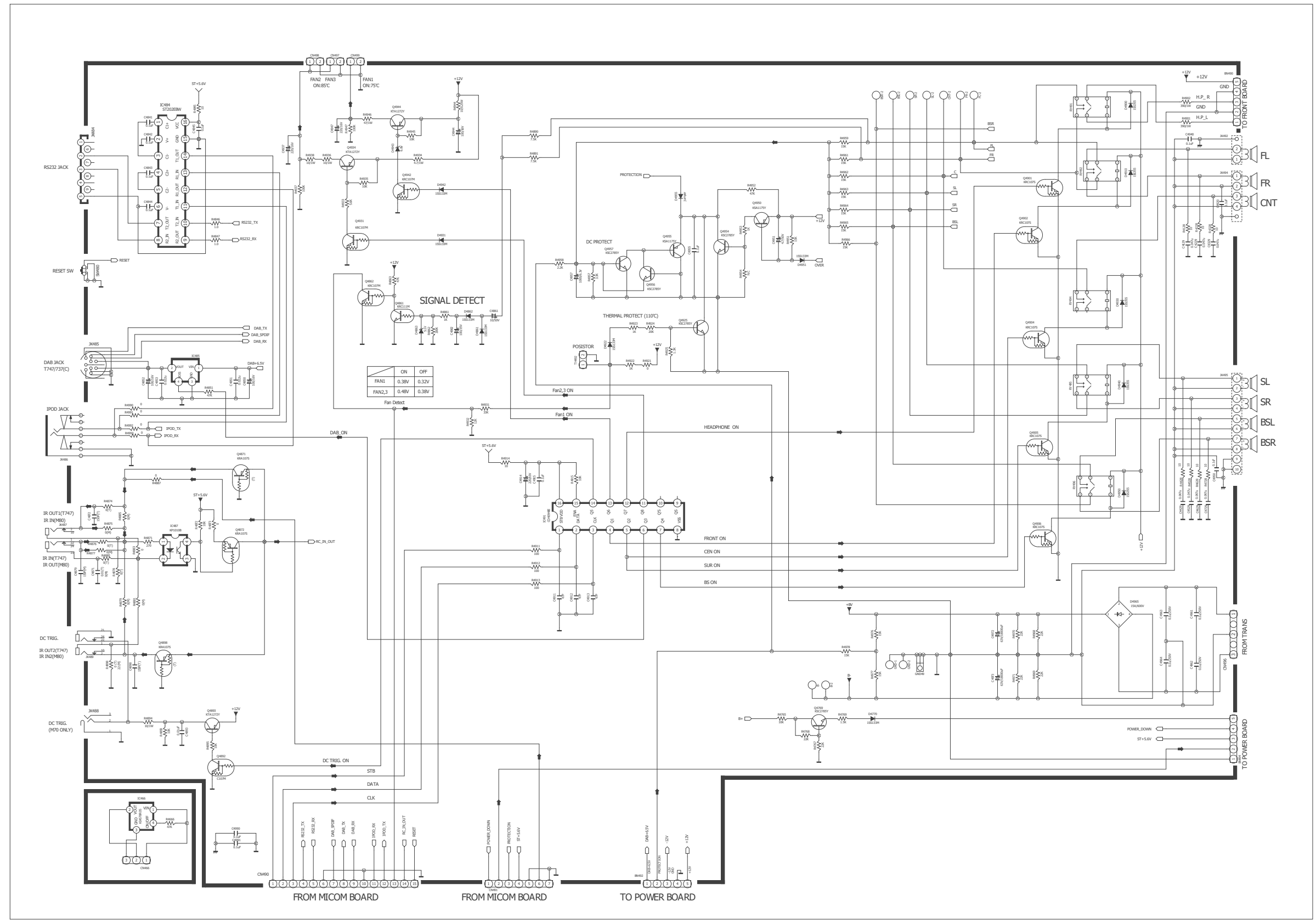

PRINTED CIRCUIT BOARDS FRONT (TOP VIEW)

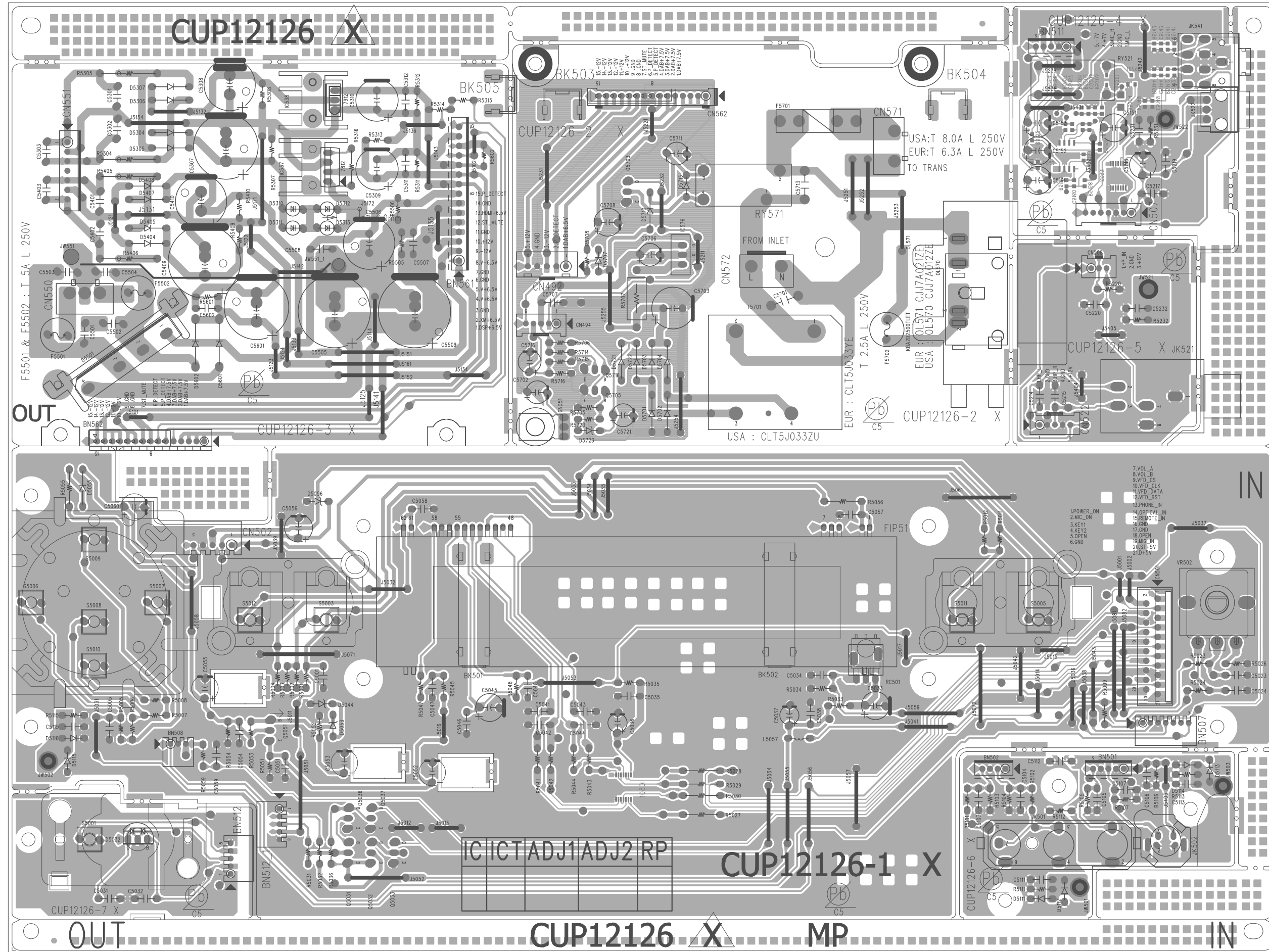

FRONT (BOTTOM VIEW)

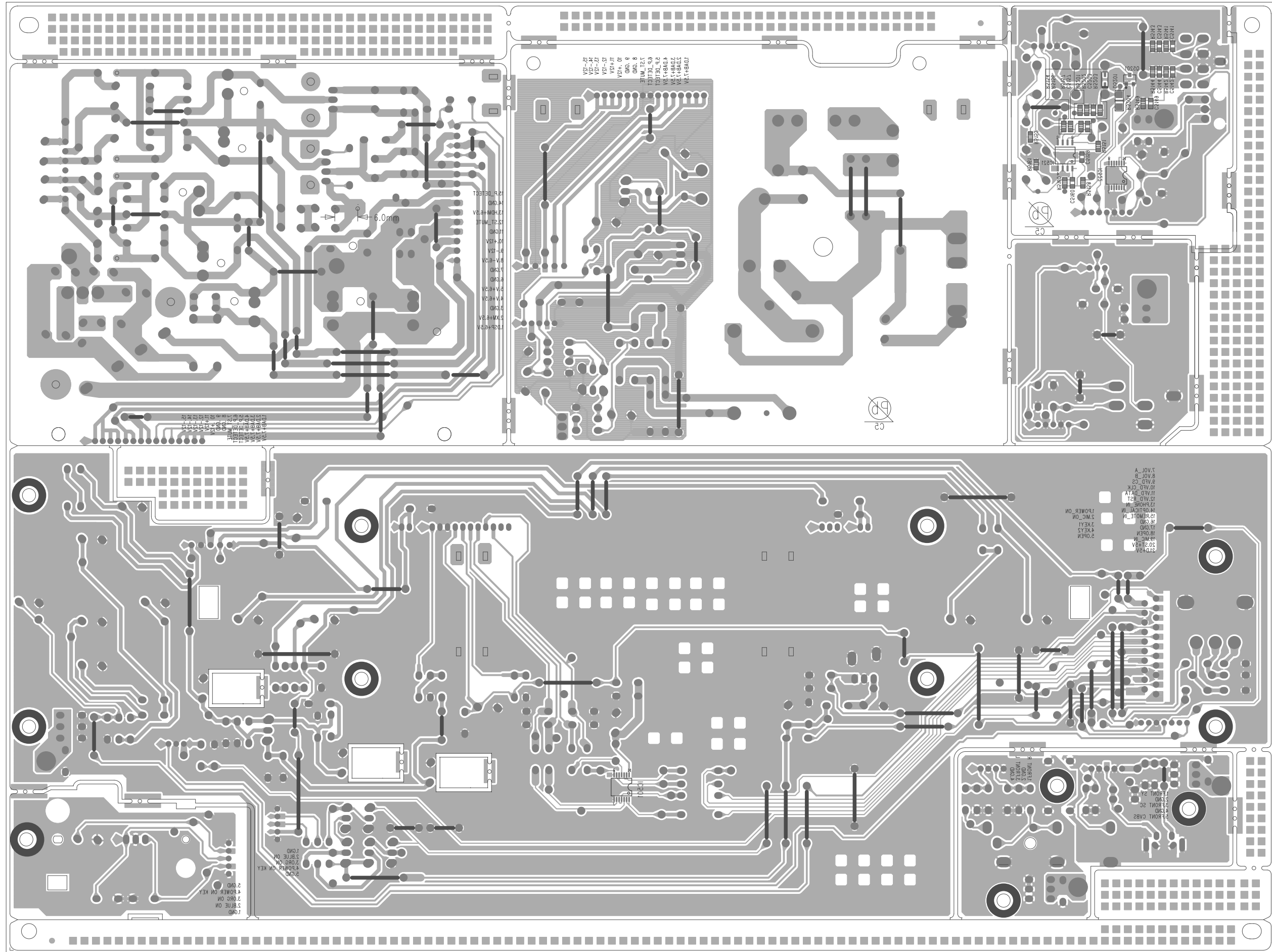

MAIN (TOP VIEW)

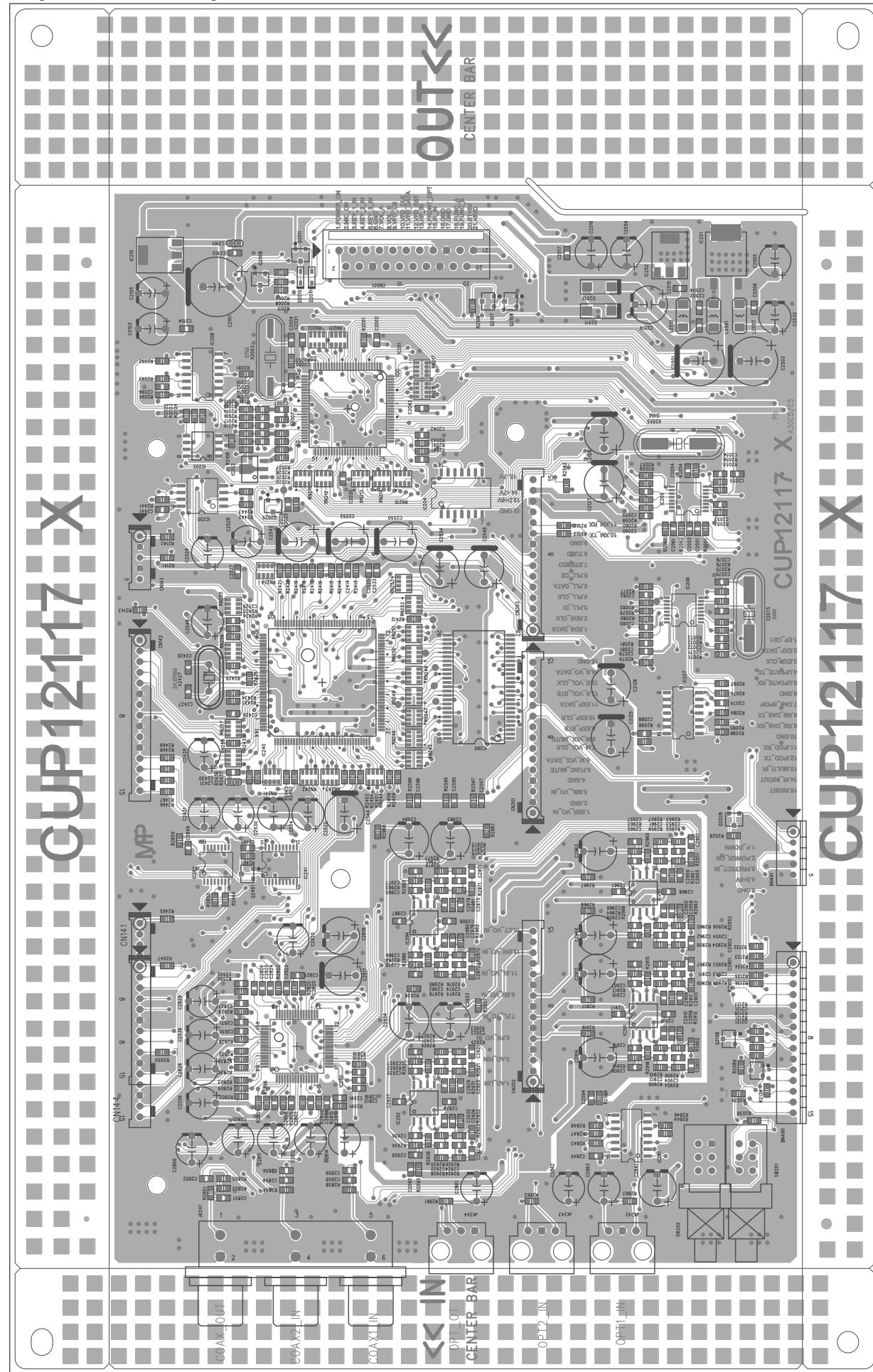

MAIN (BOTTOM VIEW)

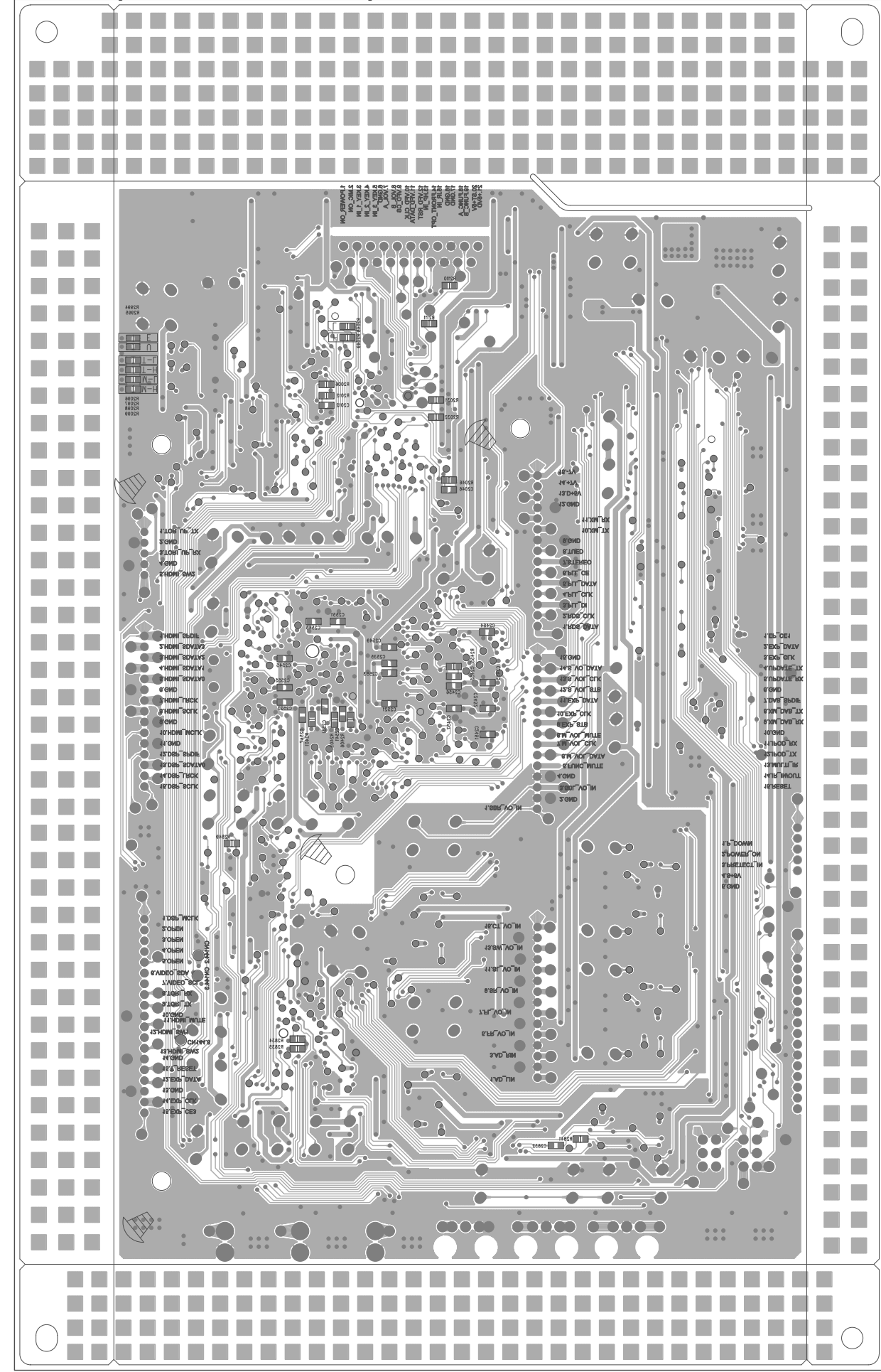

INPUT (TOP VIEW)

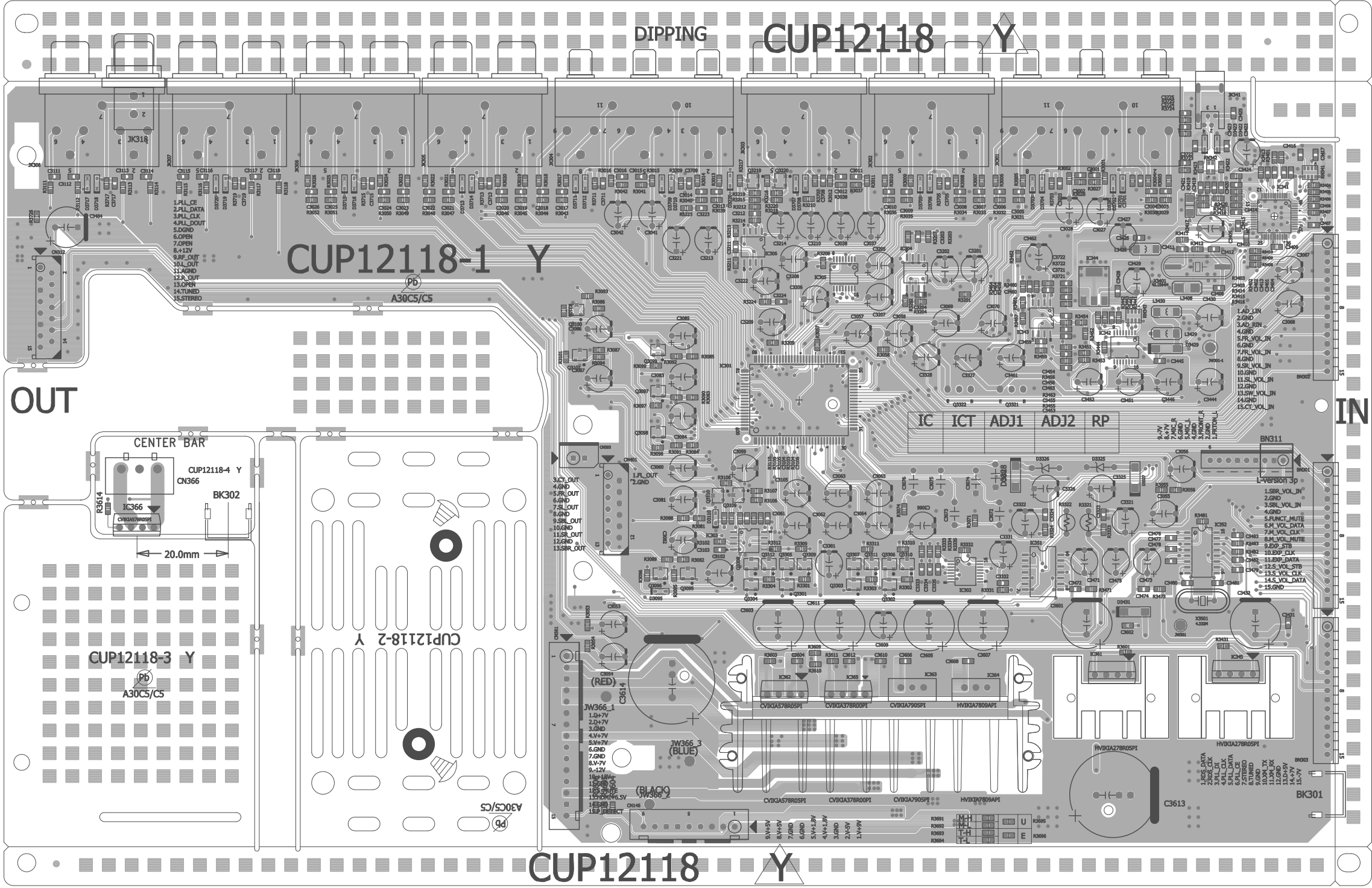

INPUT (BOTTOM VIEW)

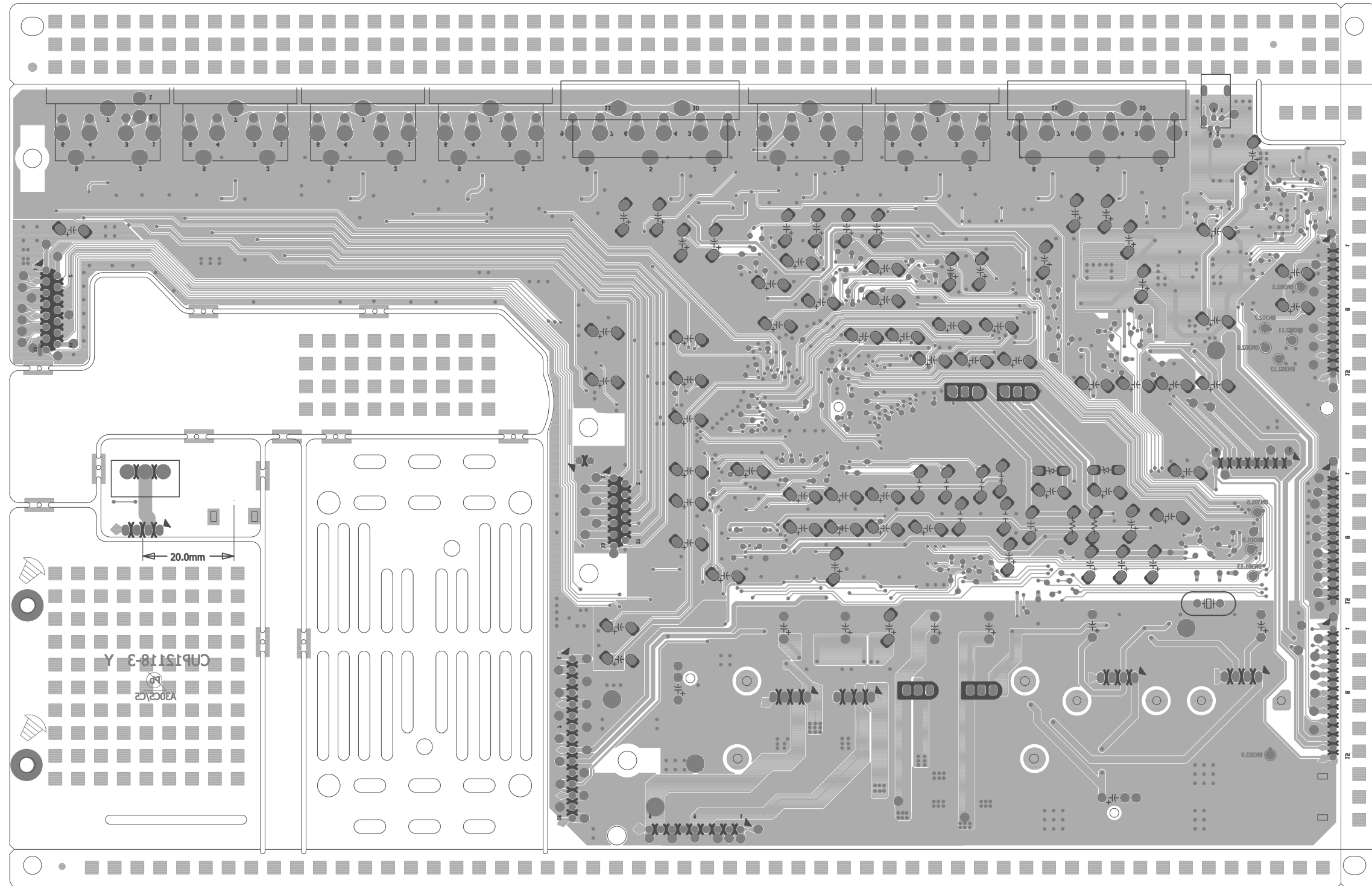

VIDEO (TOP VIEW)

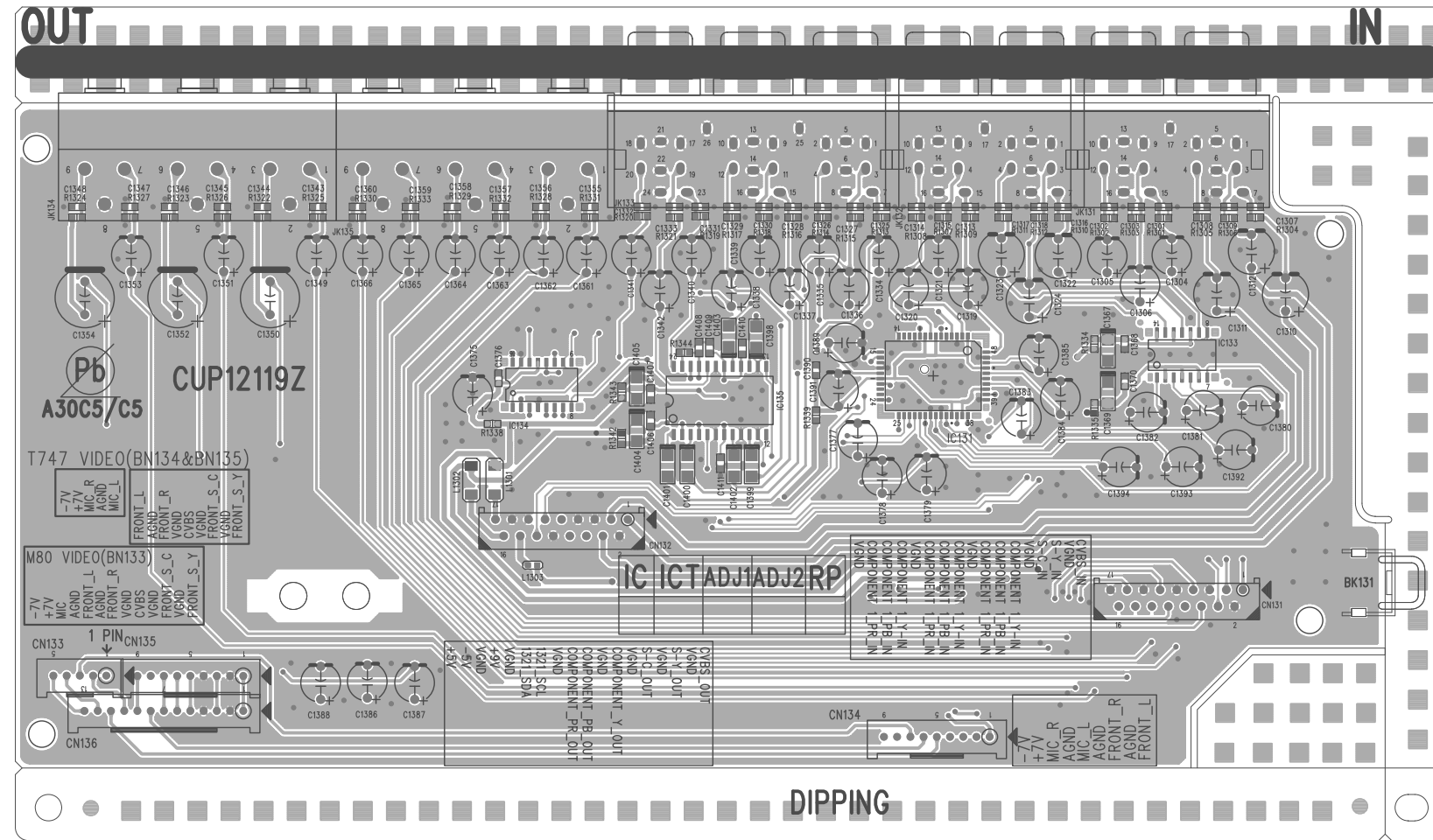

VIDEO (BOTTOM VIEW)

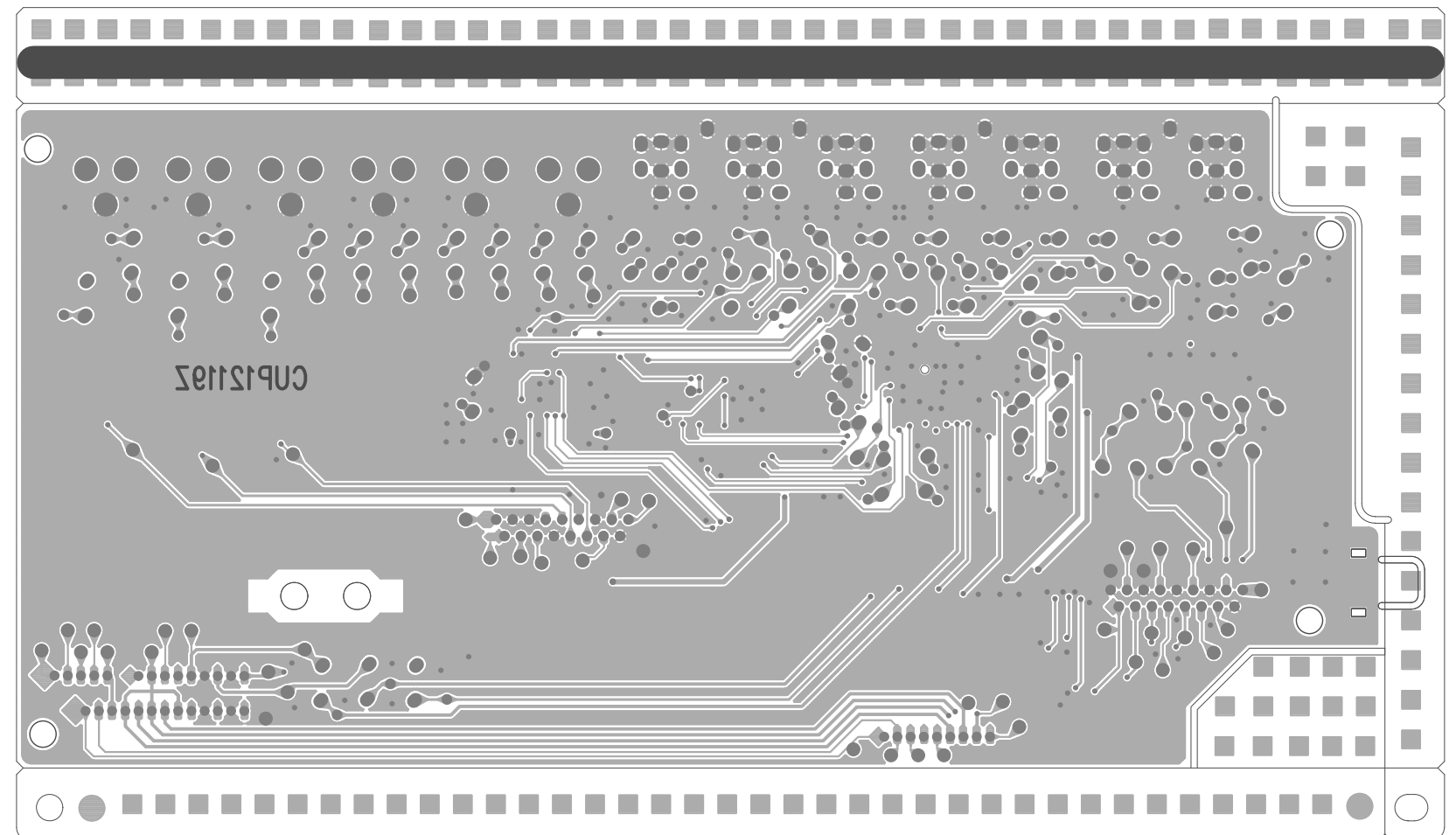

HDMI (TOP VIEW)

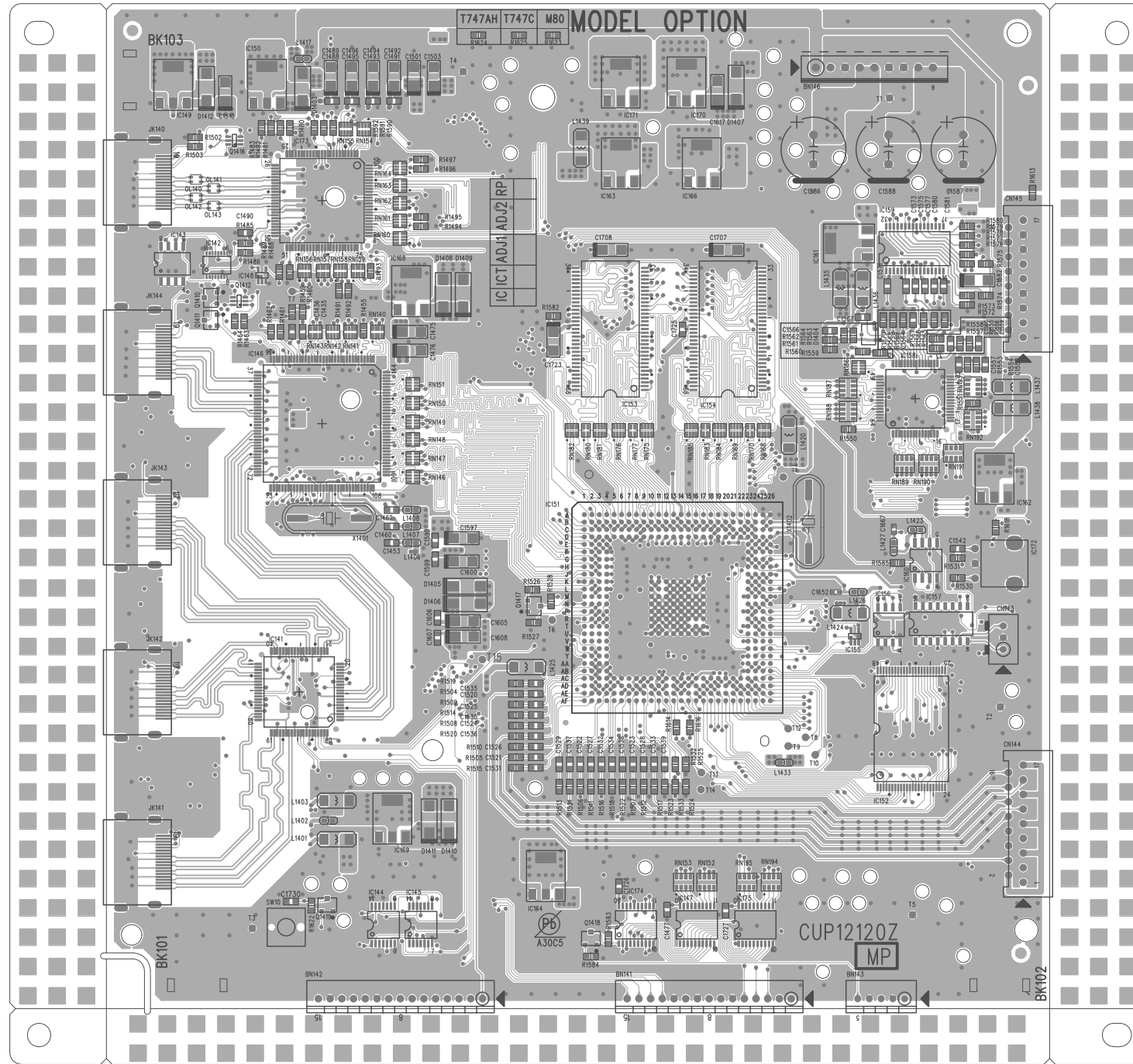

HDMI (BOTTOM VIEW)

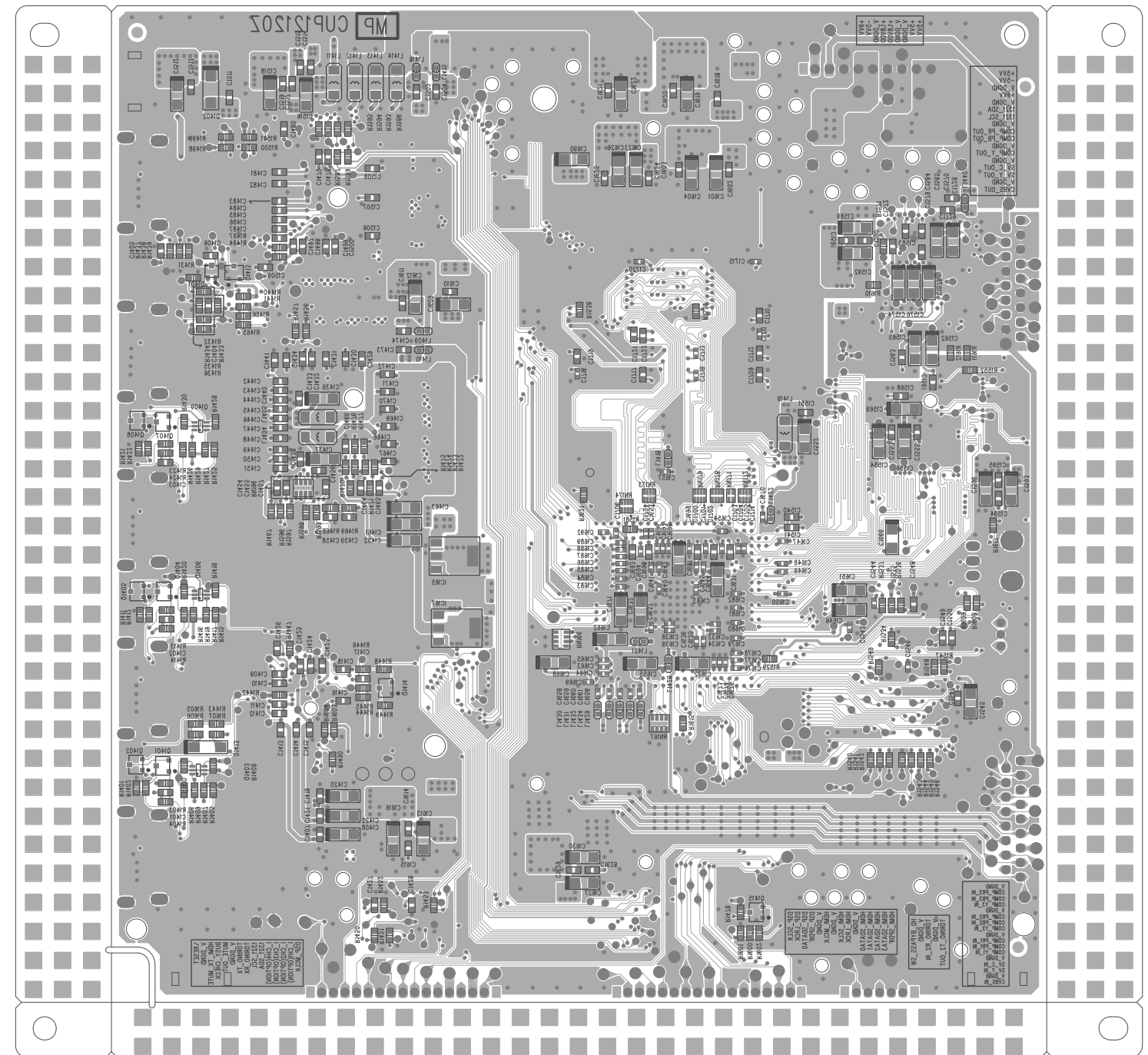

AMP (TOP VIEW)

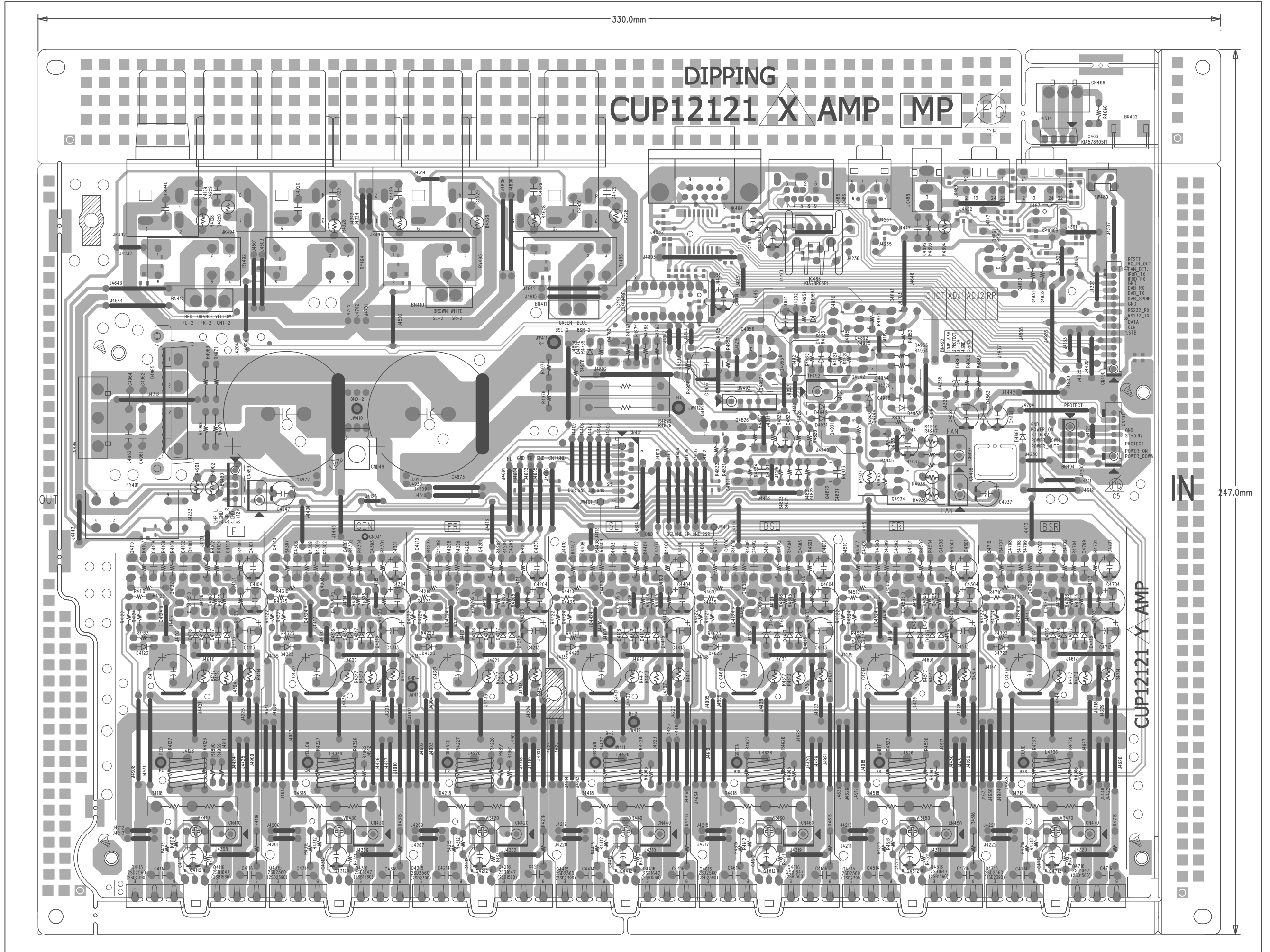

AMP (BOTTOM VIEW)

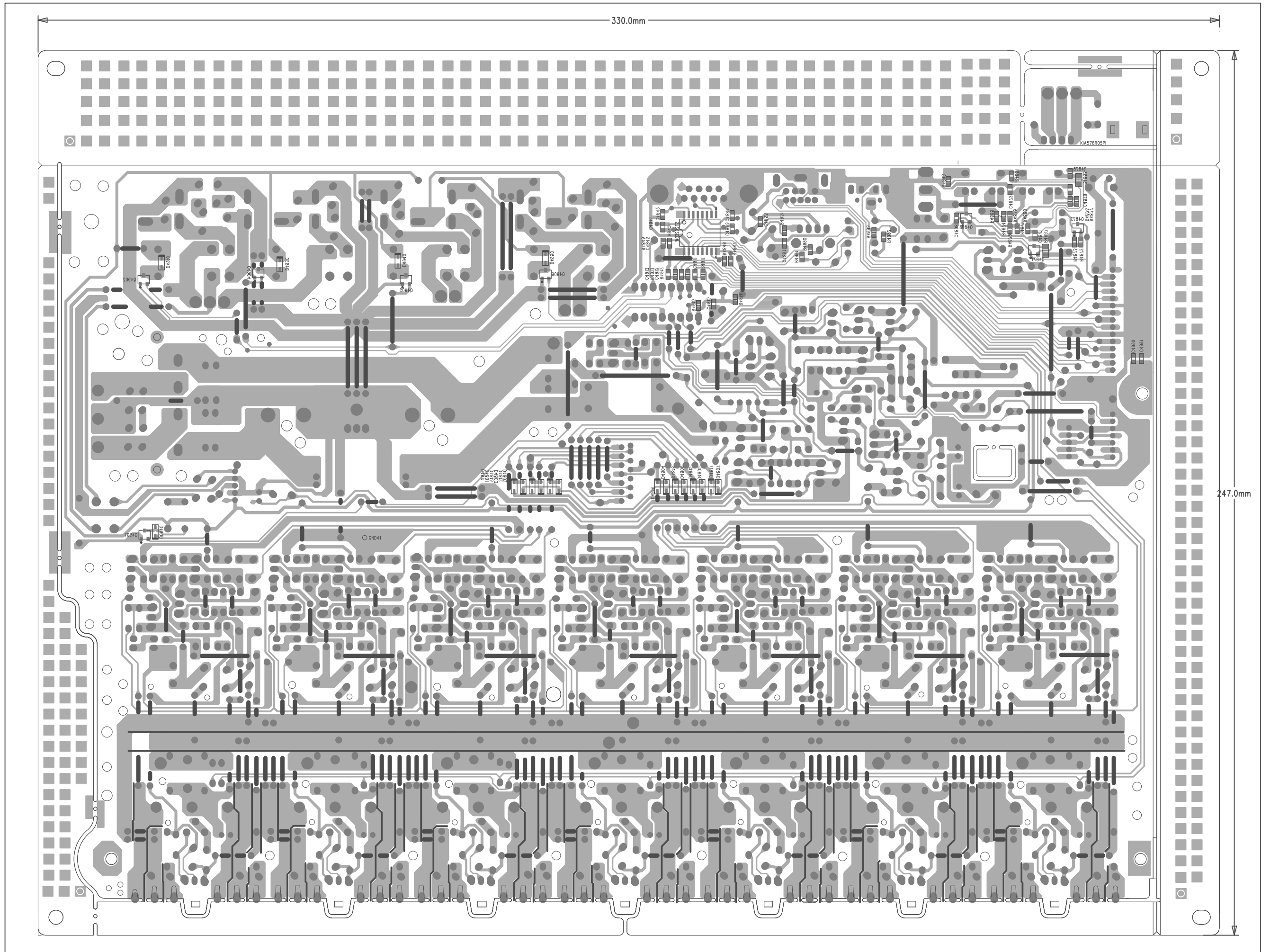

* HDMI PART TROUBLESHOOTING

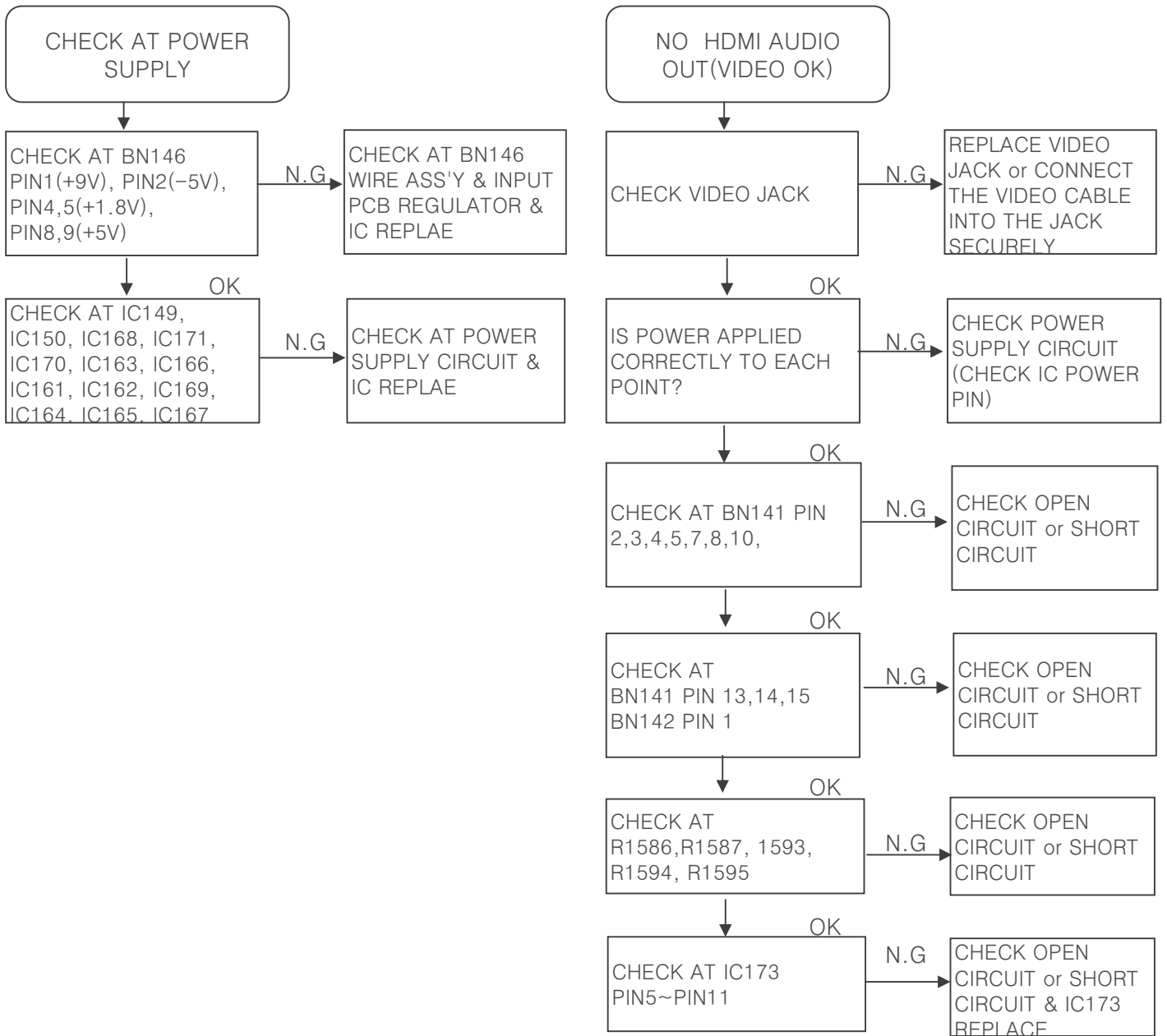

* HDMI PART TROUBLESHOOTING

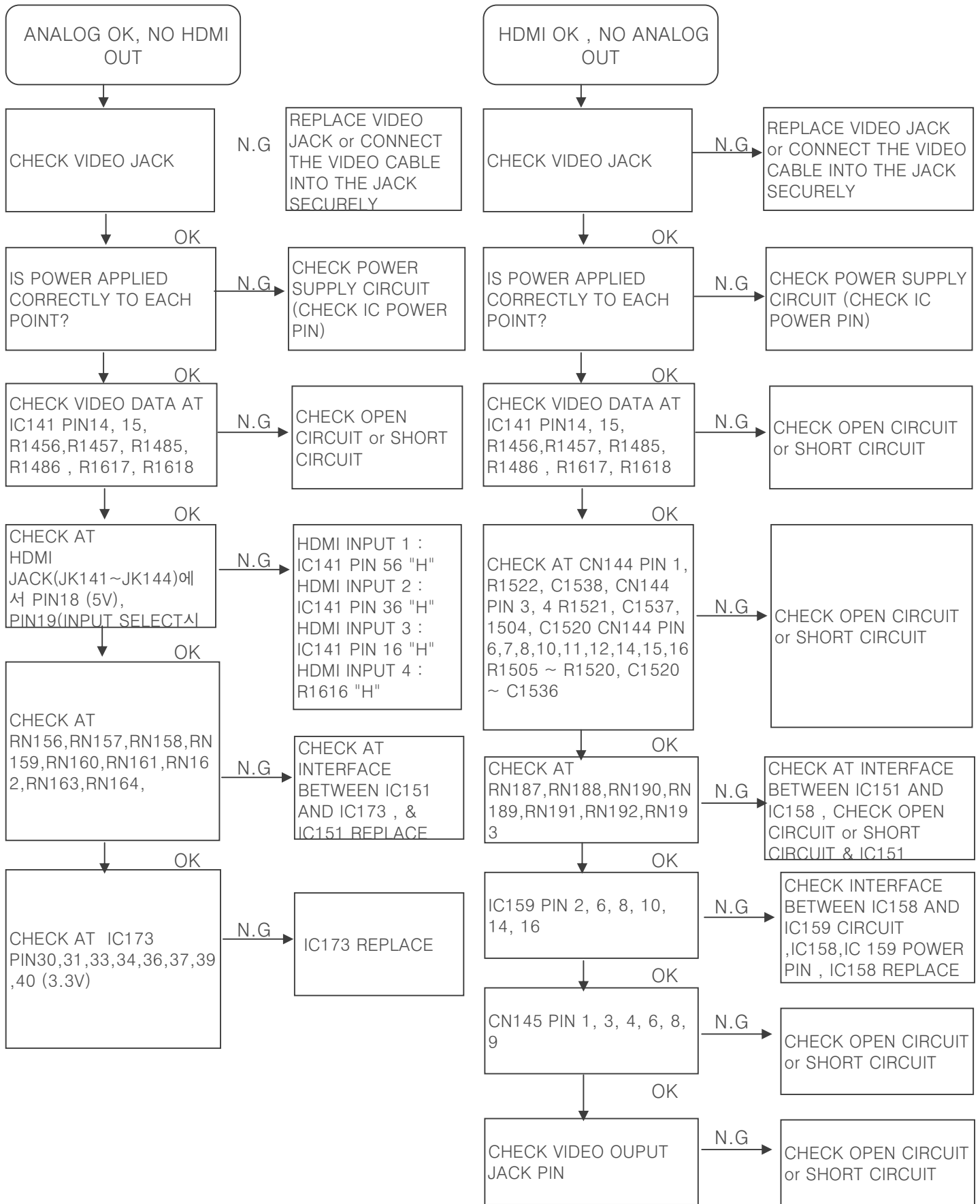

* AUDIO PART TROUBLESHOOTING

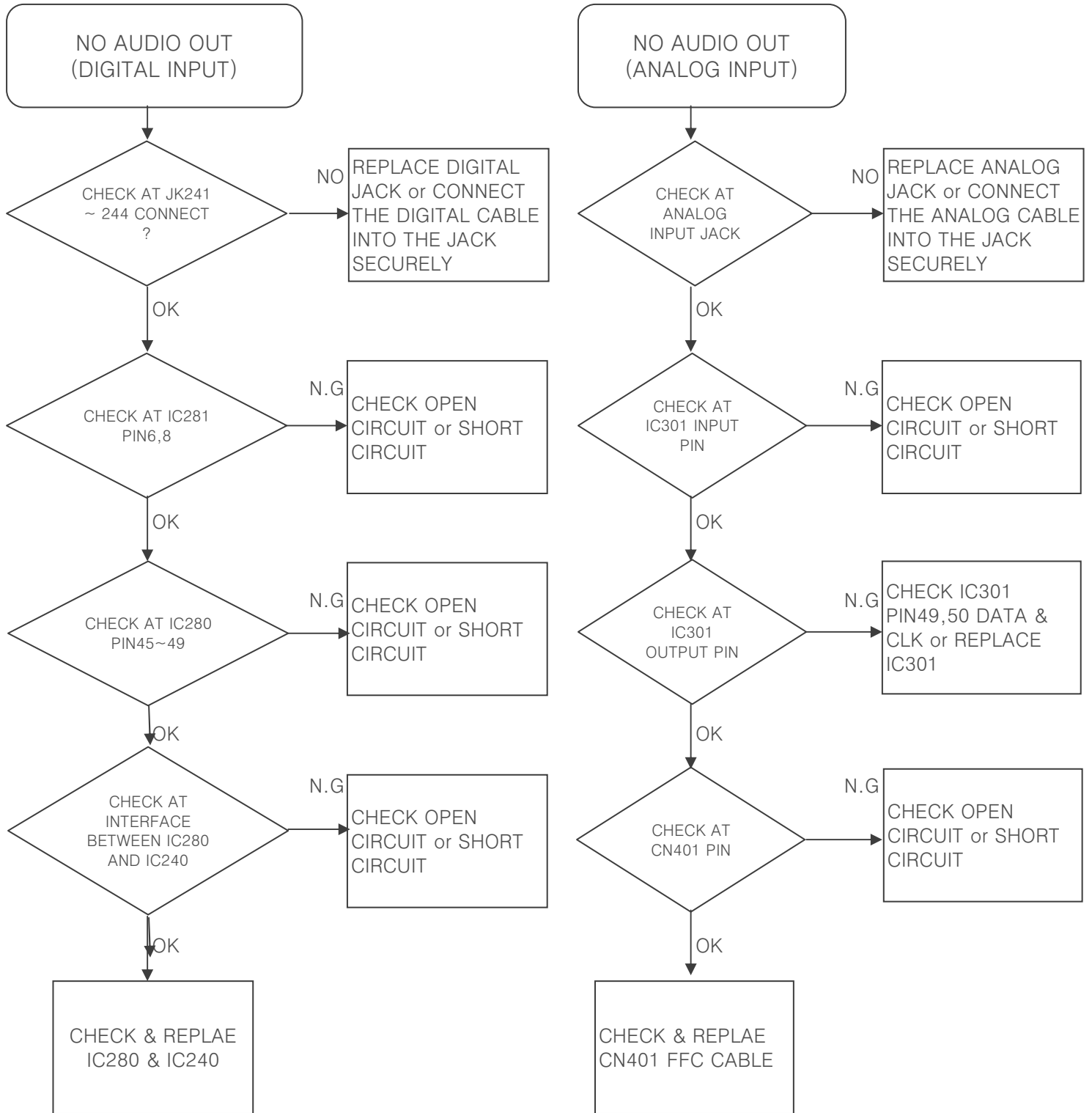

* DISPLAY PART TROUBLESHOOTING

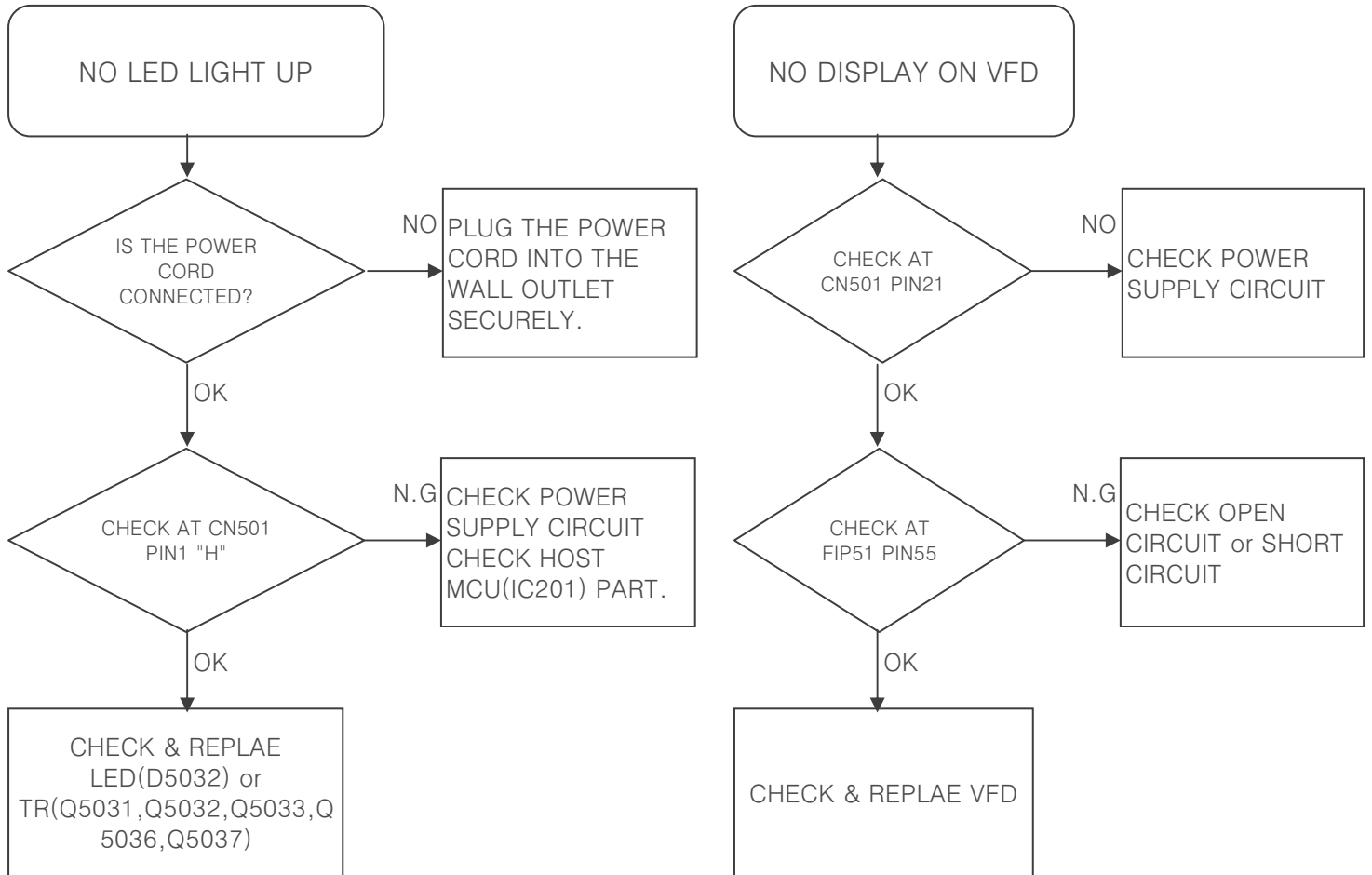

SPECIAL FUNCTION KEYS

T747		
FEATURE	REMOTE KEY OPERATING	FRONT KEY OPERATING
Micom Reset(Host+Mpeg)	-	FM FUNCTION STATE Push "LISTENING MODE" KEY(More than five seconds).
Software Version Display	-	AM FUNCTION STATE Push "LISTENING MODE" KEY(More than five seconds).
Station/Preset naming Method	FM/AM FUNCTION STATE -. Push "DISPLAY" KEY (More than three seconds) -. UP/DOWN KEY(character change) -. LEFT/RIGHT(cursor move) -. MEMORY KEY (memory seg blinking) -. MEMORY KEY (save)	-
Auto-preset Method	Push "MEMORY" KEY(More than three seconds)	-
XM Test Tone Check(1KHz)	-	XM FUNCTION STATE Push "Listening Mode" Key(More than three seconds).
XM signal strength Check	XM FUNCTION STATE Push "MENU" Key.(More than three seconds)	XM FUNCTION STATE Push "MENU" Key.(More than three seconds)
Preset Delete	TUNER DEVICE Push "DELETE" KEY-> DELETE 1 PRESET Push "DELETE" KEY(> 3 secs)-> DELETE ALL PRESET	-
AM Frequency STEP Change	-	AM function STATE Push "MENU" key(More than three seconds) AM Step 9kHz<->10kHz toggle change.
Fan Test	Press DIMMER > 3 Sec , this will toggle between ON/OFF	-
Auto EQ	Press and hold TEST key for 5 Seconds to toggle Auto EQ	-

SECTION 3

ELECTRICAL PARTS LIST

■ RESISTORS AND CAPACITORS

Notes : * Please use this part number for parts order.

* IMPORTANT SAFETY NOTICE.

Components identified by \triangle mark have special characteristics important for safety.
When replacing any of these components, use only manufacture's specified parts.

* The unit of resistance is ohm(Ω)

k=1000 Ω , M=1000k Ω

* The unit of capacitance is microfarad(μF)

p=10-6 μF

■ Numbering System of Resistor

example

CRD 25 F J 101
Type Wattage Shape Tolerance Value

RESISTOR TYPE		WATTAGE	TOLERANCE
K(C)RD	CARBON	10 : 1/10 W	F : ± 1 %
K(C)RJ	CARBON CHIP	14 : 1/4 W	J : ± 10 %
K(C)RG	METAL OXIDE	20 : 1/5 W	K : ± 20 %
K(C)RF	METAL CEMENT	25 : 1/4 W	
K(C)RQ	FUSIBLE	1 : 1 W	
		2 : 2 W	
		3 : 3 W	

■ Numbering System of Capacitor

example

CCC T 1H 101 K B
Type Voltage Value Tolerance Peculiarity

Capacitor Type	VOLTAGE		Tolerance
	HCEA Type	Other	
HCB CERAMIC	0J : 6.3V	1H : 50V DC	C : ± 0.25 pF
CCC CERAMIC	1A : 10V	1 : 125V DC	G : ± 2 %
CCK CERAMIC	1C : 16V	KC : 400V AC	J : ± 5 %
HCQ MYLAR	1E : 25V		K : ± 10 %
HCU CERAMIC CHIP	1H : 50V		Z : +80%, -20%
HCE ELECT.	1V : 35V		

LOAD No.	PARTS No.	DESCRIPTION	SPECIATION
	CUP12126X	PCB , FRONT (330X247 , FR1/1 LAYER)	
C5141	CCUS1H102KC	CAP , CHIP	
C5142	CCUS1H102KC	CAP , CHIP	
C5143	CCUS1H151JA	CAP , CHIP	
C5144	CCUS1H151JA	CAP , CHIP	
C5149	CCUS1H104KC	CAP , CHIP	
C5157	CCUS1H470JA	CAP , CHIP	
C5159	CCUS1H471JA	CAP , CHIP	
C5160	CCUS1H151JA	CAP , CHIP	
C5203	CCUS1H104KC	CAP , CHIP	
D5201	CVD1SS355T	DIODE , CHIP	
IC501	HVITC74VHCT08FT	IC , AND-GATE	
IC521	HVINJM2068MDTE1	I.C , OP AMP	
IC522	HVITC74VHCT08FT	IC , AND-GATE	
Q5201	HVTKRC102S	T.R , CHIP	
R5141	CRJ10DJ471T	RES , CHIP	
R5142	CRJ10DJ471T	RES , CHIP	
R5143	CRJ10DJ473T	RES , CHIP	
R5144	CRJ10DJ473T	RES , CHIP	
R5149	CRJ10DJ4R7T	RES , CHIP	
R5151	CRJ10DJ101T	RES , CHIP	
R5152	CRJ10DJ101T	RES , CHIP	
R5154	CRJ10DJ104T	RES , CHIP	
R5156	CRJ10DJ102T	RES , CHIP	
R5157	CRJ10DJ273T	RES , CHIP	
R5158	CRJ10DJ102T	RES , CHIP	
R5160	CRJ10DJ303T	RES , CHIP	
R5161	CRJ10DJ104T	RES , CHIP	
R5201	CRJ10DJ222T	RES , CHIP	
R5202	CRJ10DJ152T	RES , CHIP	
R5203	CRJ10DJ103T	RES , CHIP	
R5204	CRJ14CJ1R0T	RES , CHIP 1/4W	
C5001	CCBS1H102KBT	CAP , CERAMIC(1000PF/50V)	
C5005	CCBS1H102KBT	CAP , CERAMIC(1000PF/50V)	
C5023	CCBS1H223ZFT	CAP , CERAMIC(22000PF/50V)	
C5024	CCBS1H223ZFT	CAP , CERAMIC(22000PF/50V)	
C5031	CCBS1H104ZFT	CAP , CERAMIC	
C5032	CCBS1H104ZFT	CAP , CERAMIC	
C5033	CCEA1CKS101T	CAP , ELECT	
C5034	CCBS1H151KBT	CAP , CERAMIC(150PF/50V)	
C5035	CCBS1H223ZFT	CAP , CERAMIC(22000PF/50V)	
C5036	CCEA1CKS100T	CAP , ELECT	
C5037	CCEA1CKS100T	CAP , ELECT	
C5038	CCBS1H473ZFT	CAP , CERAMIC(47000PF/50V)	
C5041	CCBS1H104ZFT	CAP , CERAMIC	
C5042	CCBS1H102KBT	CAP , CERAMIC(1000PF/50V)	
C5043	CCBS1H102KBT	CAP , CERAMIC(1000PF/50V)	
C5044	CCBS1H102KBT	CAP , CERAMIC(1000PF/50V)	
C5045	CCEA1CKS101T	CAP , ELECT	
C5046	CCBS1H104ZFT	CAP , CERAMIC	
C5047	CCBS1H104ZFT	CAP , CERAMIC	
C5048	CCBS1H390JT	CAP , CERAMIC(39PF/50V)	
C5051	CCBS1H103ZFT	CAP , CERAMIC	
C5052	CCEA1JH470TS	CAP , ELECT	
C5053	CCEA1JH470TS	CAP , ELECT	
C5054	CCBS1H103ZFT	CAP , CERAMIC	
C5055	CCEA1JH470TS	CAP , ELECT	
C5056	CCEA1HKS100T	CAP , ELECT	

LOAD No.	PARTS No.	DESCRIPTION	SPECIATION
C5057	CCBS1H223ZFT	CAP , CERAMIC(22000PF/50V)	
C5058	CCBS1H223ZFT	CAP , CERAMIC(22000PF/50V)	
C5059	CCBS1H223ZFT	CAP , CERAMIC(22000PF/50V)	
C5060	CCEA1JH470TS	CAP , ELECT	
C5103	CCBS1H101KBT	CAP , CERAMIC(100PF/50V)	
C5104	CCBS1H101KBT	CAP , CERAMIC(100PF/50V)	
C5105	CCBS1H101KBT	CAP , CERAMIC(100PF/50V)	
C5106	CCBS1H101KBT	CAP , CERAMIC(100PF/50V)	
C5107	CCBS1H101KBT	CAP , CERAMIC(100PF/50V)	
C5111	CCBS1H104ZFT	CAP , CERAMIC	
C5112	CCBS1H104ZFT	CAP , CERAMIC	
C5113	CCBS1H104ZFT	CAP , CERAMIC	
C5115	CCBS1H104ZFT	CAP , CERAMIC	
C5151	CCEA1EKS470T	CAP , ELECT	
C5152	CCEA1EKS470T	CAP , ELECT	
C5153	CCEA1HKS100T	CAP , ELECT	
C5161	CCEA1HKS100T	CAP , ELECT	
C5214	CCBS1H471KBT	CAP , CERAMIC(470PF/50V)	
C5215	CCBS1H471KBT	CAP , CERAMIC(470PF/50V)	
C5217	CCBS1H104ZFT	CAP , CERAMIC	
C5218	CCEA1AH471T	CAP , ELECT	
C5219	CCBS1H104ZFT	CAP , CERAMIC	
C5220	CCBS1H104ZFT	CAP , CERAMIC	
C5231	CCBS1H104ZFT	CAP , CERAMIC	
C5232	CCBS1H104ZFT	CAP , CERAMIC	
C5301	HCQI1H103JZT	CAP , MYLAR	
C5302	HCQI1H103JZT	CAP , MYLAR	
C5303	CCME2A154JXT	CAP , METALLIZED FILM	
C5311	CCBS1H104ZFT	CAP , CERAMIC	
C5312	CCBS1H104ZFT	CAP , CERAMIC	
C5401	HCQI1H103JZT	CAP , MYLAR	
C5402	HCQI1H103JZT	CAP , MYLAR	
C5403	CCME2A154JXT	CAP , METALLIZED FILM	
C5501	CCME2A154JXT	CAP , METALLIZED FILM	
C5502	CCME2A154JXT	CAP , METALLIZED FILM	
C5503	CCME2A154JXT	CAP , METALLIZED FILM	
C5504	CCME2A154JXT	CAP , METALLIZED FILM	
C5507	CCBS1H104ZFT	CAP , CERAMIC	
C5508	CCBS1H104ZFT	CAP , CERAMIC	
C5602	CCBS1H104ZFT	CAP , CERAMIC	
C5702	CCEA1HH1R0T	CAP , ELECT	
C5706	CCEA1CH101T	CAP , ELECT	
C5707	CCBS1H104ZFT	CAP , CERAMIC	
C5708	CCEA1HH470T	CAP , ELECT	
C5711	CCEA1CH101T	CAP , ELECT	
C5716	CCEA1HHR15T	CAP , ELECT	
C5721	CCEA1HH2R2T	CAP , ELECT	
D5044	CVDZJ27BT	DIODE , ZENER	
D5053	CVDZJ13BT	DIODE , ZENER	
D5055	CVD1N4003ST	DIODE , RECT	
D5056	CVDZJ8.2BT	DIODE , ZENER	
D5111	CVD1SS133MT	DIODE	
D5112	CVD1SS133MT	DIODE	
D5113	CVD1SS133MT	DIODE	
D5114	CVD1SS133MT	DIODE	
D5115	CVD1SS133MT	DIODE	
D5116	CVD1SS133MT	DIODE	
D5306	CVD1N4003ST	DIODE , RECT	

LOAD No.	PARTS No.	DESCRIPTION	SPECIATION
D5307	CVD1N4003ST	DIODE , RECT	
D5310	CVD1N4003SRT	DIODE , RECT	
D5311	CVD1N4003SRT	DIODE , RECT	
D5312	CVD1N4003SRT	DIODE , RECT	
D5313	CVD1N4003SRT	DIODE , RECT	
D5407	CVD1N4003ST	DIODE , RECT	
D5408	CVD1N4003ST	DIODE , RECT	
D5701	CVD1N4003ST	DIODE , RECT	
D5702	CVD1N4003ST	DIODE , RECT	
D5703	CVD1N4003ST	DIODE , RECT	
D5704	CVD1N4003ST	DIODE , RECT	
D5707	CVD1SS133MT	DIODE	
D5713	CVD1SS133MT	DIODE	
D5721	CVD1N4003ST	DIODE , RECT	
D5722	CVD1N4003ST	DIODE , RECT	
D5723	CVDZJ6.8BT	DIODE , ZENER	
F5501	KBA2D5000A2EYT	FUSE (LITTLE FUSE 382 SERIES)	
F5502	KBA2D5000A2EYT	FUSE (LITTLE FUSE 382 SERIES)	
F5701	KJCF5S	HOLDER , FUSE	
F5702	KBA2D2500TLET	FUSE	
GND51	HJT1A025	PALTE , EARTH	
J5001	C3A206	WIRE , COPPER	
J5002	C3A206	WIRE , COPPER	
J5011	C3A206	WIRE , COPPER	
J5012	C3A206	WIRE , COPPER	
J5013	C3A206	WIRE , COPPER	
J5014	C3A206	WIRE , COPPER	
J5015	C3A206	WIRE , COPPER	
J5016	C3A206	WIRE , COPPER	
J5017	C3A206	WIRE , COPPER	
J5031	C3A206	WIRE , COPPER	
J5032	C3A206	WIRE , COPPER	
J5033	C3A206	WIRE , COPPER	
J5034	C3A206	WIRE , COPPER	
J5035	C3A206	WIRE , COPPER	
J5036	C3A206	WIRE , COPPER	
J5037	C3A206	WIRE , COPPER	
J5038	C3A206	WIRE , COPPER	
J5039	C3A206	WIRE , COPPER	
J5041	C3A206	WIRE , COPPER	
J5042	C3A206	WIRE , COPPER	
J5043	C3A206	WIRE , COPPER	
J5051	C3A206	WIRE , COPPER	
J5052	C3A206	WIRE , COPPER	
J5053	C3A206	WIRE , COPPER	
J5054	C3A206	WIRE , COPPER	
J5055	C3A206	WIRE , COPPER	
J5056	C3A206	WIRE , COPPER	
J5057	C3A206	WIRE , COPPER	
J5058	C3A206	WIRE , COPPER	
J5059	C3A206	WIRE , COPPER	
J5061	C3A206	WIRE , COPPER	
J5071	C3A206	WIRE , COPPER	
J5072	C3A206	WIRE , COPPER	
J5081	C3A206	WIRE , COPPER	
J5082	C3A206	WIRE , COPPER	
J5101	C3A206	WIRE , COPPER	
J5102	C3A206	WIRE , COPPER	

LOAD No.	PARTS No.	DESCRIPTION	SPECIATION
J5121	C3A206	WIRE , COPPER	
J5122	C3A206	WIRE , COPPER	
J5123	C3A206	WIRE , COPPER	
J5124	C3A206	WIRE , COPPER	
J5125	C3A206	WIRE , COPPER	
J5131	C3A206	WIRE , COPPER	
J5132	C3A206	WIRE , COPPER	
J5133	C3A206	WIRE , COPPER	
J5134	C3A206	WIRE , COPPER	
J5135	C3A206	WIRE , COPPER	
J5136	C3A206	WIRE , COPPER	
J5141	C3A206	WIRE , COPPER	
J5142	C3A206	WIRE , COPPER	
J5143	C3A206	WIRE , COPPER	
J5144	C3A206	WIRE , COPPER	
J5151	C3A206	WIRE , COPPER	
J5152	C3A206	WIRE , COPPER	
J5154	C3A206	WIRE , COPPER	
J5161	C3A206	WIRE , COPPER	
J5211	C3A206	WIRE , COPPER	
J5221	C3A206	WIRE , COPPER	
J5231	C3A206	WIRE , COPPER	
J5232	C3A206	WIRE , COPPER	
J5242	C3A206	WIRE , COPPER	
J5251	C3A206	WIRE , COPPER	
J5252	C3A206	WIRE , COPPER	
J5253	C3A206	WIRE , COPPER	
J5254	C3A206	WIRE , COPPER	
J5255	C3A206	WIRE , COPPER	
J5403	C3A206	WIRE , COPPER	
J5404	C3A206	WIRE , COPPER	
J5405	C3A206	WIRE , COPPER	
J5431	C3A206	WIRE , COPPER	
J5432	C3A206	WIRE , COPPER	
L5057	HLQ02C100KT	COIL , AXAIL	
Q5031	HVTKRA102MT	T.R	
Q5032	HVTKRA102MT	T.R	
Q5033	HVTKRC102MT	T.R	
Q5036	HVTKRC102MT	T.R	
Q5037	HVTKRC102MT	T.R	
Q5051	HVTKSC2316YT	T.R	
Q5703	HVTKRC107MT	T.R	
Q5705	HVTKSC2785YT	T.R	
Q5705	HVTKTC3199YT	T.R	
Q5716	HVTKRC107MT	T.R	
R5001	CRD20TF1001T	RES , CARBON	
R5002	CRD20TF1501T	RES , CARBON	
R5003	CRD20TF1801T	RES , CARBON	
R5004	CRD20TF2701T	RES , CARBON	
R5005	CRD20TF1001T	RES , CARBON	
R5006	CRD20TF1501T	RES , CARBON	
R5007	CRD20TF1801T	RES , CARBON	
R5008	CRD20TF2701T	RES , CARBON	
R5009	CRD20TJ4R7T	RES , CARBON	
R5011	CRD20TF3301T	RES , CARBON	
R5012	CRD20TF5601T	RES , CARBON(5.6K/F)	
R5023	CRD20TJ272T	RES , CARBON	
R5024	CRD20TJ272T	RES , CARBON	

LOAD No.	PARTS No.	DESCRIPTION	SPECIATION
R5026	CRD20TJ101T	RES , CARBON	
R5027	CRD20TJ102T	RES , CARBON	
R5028	CRD20TJ102T	RES , CARBON	
R5029	CRD20TJ102T	RES , CARBON	
R5030	CRD20TJ102T	RES , CARBON	
R5031	CRD20TJ681T	RES , CARBON	
R5032	CRD20TJ561T	RES , CARBON	
R5033	CRD20TJ4R7T	RES , CARBON	
R5034	CRD20TJ473T	RES , CARBON	
R5035	CRD20TJ4R7T	RES , CARBON	
R5036	CRD20TJ103T	RES , CARBON	
R5041	CRD20TJ470T	RES , CARBON	
R5042	CRD20TJ470T	RES , CARBON	
R5043	CRD20TJ470T	RES , CARBON	
R5044	CRD20TJ470T	RES , CARBON	
R5045	CRD20TJ100T	RES , CARBON	
R5047	CRD20TJ100T	RES , CARBON	
R5048	CRD20TJ822T	RES , CARBON	
R5051	CRD20TJ473T	RES , CARBON	
R5052	CRD20TJ104T	RES , CARBON	
R5053	CRD20TJ122T	RES , CARBON	
R5054	CRD20TJ104T	RES , CARBON	
R5055	CRD25FJ2R2T	RES , CARBON	
R5056	CRD25FJ2R2T	RES , CARBON	
R5059	CRD20TJ102T	RES , CARBON	
R5101	CRD20TJ471T	RES , CARBON	
R5102	CRD20TJ471T	RES , CARBON	
R5103	CRD20TJ104T	RES , CARBON	
R5104	CRD20TJ104T	RES , CARBON	
R5105	CRD20TJ750T	RES , CARBON	
R5106	CRD20TJ750T	RES , CARBON	
R5107	CRD20TJ750T	RES , CARBON	
R5111	CRD20TJ4R7T	RES , CARBON	
R5112	CRD20TJ4R7T	RES , CARBON	
R5113	CRD20TJ4R7T	RES , CARBON	
R5115	CRD20TJ4R7T	RES , CARBON	
R5220	CRD20TJ4R7T	RES , CARBON	
R5231	CRD20TJ4R7T	RES , CARBON	
R5307	CRD20TJ473T	RES , CARBON	
R5308	CRD20TJ473T	RES , CARBON	
R5311	CRD20TJ473T	RES , CARBON	
R5312	CRD20TJ473T	RES , CARBON	
R5313	CRD20TJ153T	RES , CARBON	
R5314	CRD20TJ153T	RES , CARBON	
R5315	CRD20TJ153T	RES , CARBON	
R5316	CRD20TJ153T	RES , CARBON	
R5409	CRD20TJ473T	RES , CARBON	
R5410	CRD20TJ473T	RES , CARBON	
R5505	CRD20TJ473T	RES , CARBON	
R5506	CRD20TJ473T	RES , CARBON	
R5602	CRD20TJ473T	RES , CARBON	
R5705	CRD20TJ223T	RES , CARBON	
R5706	CRD20TJ472T	RES , CARBON	
R5708	CRD20TJ271T	RES , CARBON	
R5714	CRD20TJ472T	RES , CARBON	
R5715	CRD20TJ102T	RES , CARBON	
R5716	CRD20TJ223T	RES , CARBON	
R5723	CRD20TJ103T	RES , CARBON	

LOAD No.	PARTS No.	DESCRIPTION	SPECIATION
S5001	CST1A012ZT	SW , TACT	
S5003	CST1A012ZT	SW , TACT	
S5005	CST1A012ZT	SW , TACT	
S5006	CST1A012ZT	SW , TACT	
S5007	CST1A012ZT	SW , TACT	
S5008	CST1A012ZT	SW , TACT	
S5009	CST1A012ZT	SW , TACT	
S5010	CST1A012ZT	SW , TACT	
S5011	CST1A012ZT	SW , TACT	
S5012	CST1A012ZT	SW , TACT	
BK501	CMD1A691	BRACKET , FLT	
BK502	CMD1A691	BRACKET , FLT	
BK503	CMD1A569	BRACKET , PCB	
BK504	CMD1A569	BRACKET , PCB	
BK505	CMD1A569	BRACKET , PCB	
BN501	CWB1B00950047001	WIRE ASS'Y (SHIELD,9PIN,2mm,500mm,STRAIGH,#26)	
BN507	CWB1B00710046	WIRE ASS'Y (7PIN,2mm,100mm,ANGLE,#26)	
BN508	CWB1B00310046	WIRE ASS'Y (3PIN,2mm,100mm,STRAIGHT,#26)	
BN511	CWB1B00540047002	WIRE ASS'Y (SHIELD,5PIN,2mm,400mm,STRAIGH,#26)	
BN512	CWB1B00518066	WIRE ASS'Y (5PIN,2mm,180mm,STRAIGHT,#26)	
BN561	CWB1D01535058	WIRE ASS'Y (15PIN,2.5mm,350mm,STRAIGHT,#22)	
BN562	CJP15GB99ZM	WAFER	
BN562	CJP15GB99ZY	WAFER	
CN492	CJP05GI237ZW	LOCKING TYPE , STRAIGHT WAFER , 2.5MM	
CN494	CJP05GI236ZW	LOCKING TYPE , STRAIGHT WAFER , 2mm	
CN501	CJP21GA202ZY	WAFER , CARDCABLE(21P , 1.25mm , ANGLE)	
CN502	CJP05GB03ZY	WAFER , ANGLE (2.5mm)	
CN507	CJP07GI236ZW	LOCKING TYPE , STRAIGHT WAFER , 2MM	
CN508	CJP03GI236ZW	LOCKING TYPE , STRAIGHT WAFER , 2MM	
CN522	CJP05GI236ZW	LOCKING TYPE , STRAIGHT WAFER , 2mm	
CN550	CJP03GA90ZY	WAFER	
CN551	CJP07GA01ZY	WAFER , STRAIGHT(7PIN)	
CN562	CJP15GA98ZM	WAFER	
CN562	CJP15GA98ZY	WAFER	
CN571	CJP02GA89ZY	WAFER	
CN572	CJP02KA060ZY	WAFER	
C5307	CCEA1EH472E	CAP , ELECT	
C5308	CCEA1EH222E	CAP , ELECT	
C5309	CCEA1CH102E	CAP , ELECT	
C5310	CCEA1CH102E	CAP , ELECT	
C5409	CCEA1CH103E	CAP , ELECT	
C5410	CCEA1EH222E	CAP , ELECT	
C5505	CCEA1CH103E	CAP , ELECT	
C5506	CCEA1CH332E	CAP , ELECT	
C5509	CCEA1CH103E	CAP , ELECT	
C5601	CCEA1CH682E	CAP , ELECT	
C5701	KCKDKS472ME	CAP , CERAMIC(X1/Y2/SC)	
C5703	CCEA1EH102E	CAP , ELECT	
C5713	KCKDKS472ME	CAP , CERAMIC(X1/Y2/SC)	
D5032	CVD50BOBBWGA	L.E.D , 2 COLOR (ORG , BLUE)	
D5304	HVDSB2100	DIODE , SCHOTTKY	
D5305	HVDSB2100	DIODE , SCHOTTKY	
D5404	HVDSB2100	DIODE , SCHOTTKY	
D5405	HVDSB2100	DIODE , SCHOTTKY	
D5501	CMY1A138VA	HEAT SINK ASS'Y	
	HVDGBJ806	DIODE , BRIDGE	
D5601	HVD2A04H	DIODE , RECT(2A)	
D5602	HVD2A04H	DIODE , RECT(2A)	

LOAD No.	PARTS No.	DESCRIPTION	SPECIATION
D5710	HVD1N5819T	DIODE , SCHOTTKY	
FIP51	CFLHCA16S201T	V.F.D	
IC537	CVIKIA278R12PIGA	I.C HEATSINK ASS'Y (CMY3A025)	
	HVIKIA278R12PI	REGULATOR(12V OUTPUT LOW DROP)	
IC538	CVIKIA7912APICA	I.C HEAT SINK ASS'Y(CMY4A025)	
	HVIKIA7912PI	I.C , REGULATOR	
IC576	CVIKIA78DL05PI	I.C , REGULATOR(250mA, TO220IS-3)	
JK501	CJJ4S047Z	JACK , RCA (3P , W/R/Y , GOLD PLATE)	
JK502	CJJ9M004Z	JACK , S-VHS	
JK521	CJJ2E020Z	JACK	
JK522	HJSTORX177L	MODULE , OPTICAL(RX)	
JK541	CJJ2E028Z	JACK , MEDIA PLAYER & MIC JACK (3.5mm, GOLD)	
JW551	CWE8202120AA	WIRE , 1P BLACK(120MM)	
OL570	CJJ7A012Z	JACK , AC OUTLET(USA)	ONLY AH VERSION
OL571	CJJ7A021Z	JACK , AC OUTLET(EUR)	ONLY C VERSION
RC501	CRVKSM603TM2M	SENSOR , REMOCON(H=5.2MM)	
RY521	CSL4A016ZU	RELAY , 12V 2C2P	
RY571	HSL1A008ZE	RELAY	
R5304	KRQ1AJR15H	RES , FUSE	
R5305	KRQ1AJR15H	RES , FUSE	
R5405	KRQ1AJR15H	RES , FUSE	
R5406	KRQ1AJR15H	RES , FUSE	
R5707	CRG1ANJ100H	RES , METAL OXIDE FILM	
T5701	CLT5J033ZU	TRANS , SUB	ONLY AH VERSION
T5701	CLT5J033YE	TRANS , SUB	ONLY C VERSION
VR502	CSR2A036Z	ENCODER VR	
	CUP12117W	PCB , MCU & DSP T747 (253X160 , FR4/2 LAYER)	
C2002	CCUS1H104KC	CAP , CHIP	
C2004	CCUS1H180JA	CAP , CHIP(18PF/50V)	
C2005	CCUS1H180JA	CAP , CHIP(18PF/50V)	
C2007	CCUS1H104KC	CAP , CHIP	
C2012	CCUS1H104KC	CAP , CHIP	
C2013	CCUS1H101JA	CAP , CHIP	
C2014	CCUS1H101JA	CAP , CHIP	
C2015	CCUS1H101JA	CAP , CHIP	
C2016	CCUS1H101JA	CAP , CHIP	
C2017	CCUS1H101JA	CAP , CHIP	
C2021	CCUS1H104KC	CAP , CHIP	
C2025	CCUS1H104KC	CAP , CHIP	
C2030	CCUS1H104KC	CAP , CHIP	
C2041	CCUS1H104KC	CAP , CHIP	
C2042	CCUS1H101JA	CAP , CHIP	
C2043	CCUS1H104KC	CAP , CHIP	
C2046	CCUS1H104KC	CAP , CHIP	
C2051	CCUS1H101JA	CAP , CHIP	
C2052	CCUS1H101JA	CAP , CHIP	
C2053	CCUS1H101JA	CAP , CHIP	
C2054	CCUS1H101JA	CAP , CHIP	
C2055	CCUS1H220JA	CAP , CHIP	
C2056	CCUS1H220JA	CAP , CHIP	
C2059	CCUS1H101JA	CAP , CHIP	
C2060	CCUS1H104KC	CAP , CHIP	
C2061	CCUS1H104KC	CAP , CHIP	
C2071	CCUS1H101JA	CAP , CHIP	
C2072	CCUS1H101JA	CAP , CHIP	
C2074	CCUS1H101JA	CAP , CHIP	
C2075	CCUS1H220JA	CAP , CHIP	
C2076	CCUS1H220JA	CAP , CHIP	

LOAD No.	PARTS No.	DESCRIPTION	SPECIATION
C2079	CCUS1H104KC	CAP , CHIP	
C2080	CCUS1H101JA	CAP , CHIP	
C2081	CCUS1H101JA	CAP , CHIP	
C2082	CCUS1H101JA	CAP , CHIP	
C2088	CCUS1H104KC	CAP , CHIP	
C2094	CCUS1H104KC	CAP , CHIP	
C2102	CCUS1H104KC	CAP , CHIP	
C2104	CCUS1H104KC	CAP , CHIP	
C2414	CCUS1H104KC	CAP , CHIP	
C2426	CCUS1H180JA	CAP , CHIP(18PF/50V)	
C2427	CCUS1H150JA	CAP , CHIP(15PF/50V)	
C2429	CCUS1H103KC	CAP , CHIP	
C2430	CCUS1A105KC	CAP , CHIP	
C2441	CCUS1H104KC	CAP , CHIP	
C2451	CCUS1H104KC	CAP , CHIP	
C2452	CCUS1H104KC	CAP , CHIP	
C2453	CCUS1H104KC	CAP , CHIP	
C2454	CCUS1H104KC	CAP , CHIP	
C2456	CCUS1H104KC	CAP , CHIP	
C2457	CCUS1H104KC	CAP , CHIP	
C2461	CCUS1H104KC	CAP , CHIP	
C2502	CCUS1H104KC	CAP , CHIP	
C2504	CCUS1H104KC	CAP , CHIP	
C2506	CCUS1H104KC	CAP , CHIP	
C2515	CCUS1H104KC	CAP , CHIP	
C2517	CCUS1H104KC	CAP , CHIP	
C2521	CCUS1H104KC	CAP , CHIP	
C2523	CCUS1H104KC	CAP , CHIP	
C2525	CCUS1H104KC	CAP , CHIP	
C2527	CCUS1H104KC	CAP , CHIP	
C2529	CCUS1H104KC	CAP , CHIP	
C2531	CCUS1H104KC	CAP , CHIP	
C2533	CCUS1H104KC	CAP , CHIP	
C2535	CCUS1H104KC	CAP , CHIP	
C2541	CCUS1H104KC	CAP , CHIP	
C2543	CCUS1H104KC	CAP , CHIP	
C2545	CCUS1H104KC	CAP , CHIP	
C2547	CCUS1H104KC	CAP , CHIP	
C2549	CCUS1H104KC	CAP , CHIP	
C2551	CCUS1H104KC	CAP , CHIP	
C2553	CCUS1H104KC	CAP , CHIP	
C2555	CCUS1H104KC	CAP , CHIP	
C2591	CCUS1H104KC	CAP , CHIP	
C2592	CCUS1H104KC	CAP , CHIP	
C2593	CCUS1H104KC	CAP , CHIP	
C2594	CCUS1H104KC	CAP , CHIP	
C2595	CCUS1H104KC	CAP , CHIP	
C2596	CCUS1H104KC	CAP , CHIP	
C2597	CCUS1H104KC	CAP , CHIP	
C2807	CCUS1H104KC	CAP , CHIP	
C2808	CCUS1H104KC	CAP , CHIP	
C2809	CCUS1H102KC	CAP , CHIP	
C2810	CCUS1H104KC	CAP , CHIP	
C2813	CCUS1H104KC	CAP , CHIP	
C2816	CCUS1H104KC	CAP , CHIP	
C2818	CCUS1H104KC	CAP , CHIP	
C2820	CCUS1H102KC	CAP , CHIP	
C2821	CCUS1H223KC	CAP , CHIP	

LOAD No.	PARTS No.	DESCRIPTION	SPECIATION
C2822	CCUS1H104KC	CAP , CHIP	
C2824	CCUS1H103KC	CAP , CHIP	
C2825	CRJ10DJ0R0T	RES , CHIP	
C2826	CRJ10DJ0R0T	RES , CHIP	
C2827	CRJ10DJ0R0T	RES , CHIP	
C2830	CCUS1H104KC	CAP , CHIP	
C2831	CCUS1H104KC	CAP , CHIP	
C2832	CLZ9R005Z	FERRITE , CHIP BEAD(60ohm, 1608)	
C2840	CCUS1H473KC	CAP , CHIP	
C2849	CCUS1H104KC	CAP , CHIP	
C2851	CCUS1H101JA	CAP , CHIP	
C2852	CCUS1H104KC	CAP , CHIP	
C2854	CCUS1H181JA	CAP , CHIP	
C2856	CCUS1H104KC	CAP , CHIP	
C2858	CCUS1H181JA	CAP , CHIP	
C2859	CCUS1H104KC	CAP , CHIP	
C2901	CCUS1H152KC	CAP , CHIP	
C2902	CCUS1H152KC	CAP , CHIP	
C2903	CCUS1H152KC	CAP , CHIP	
C2904	CCUS1H152KC	CAP , CHIP	
C2905	CCUS1H102KC	CAP , CHIP	
C2906	CCUS1H102KC	CAP , CHIP	
C2907	CCUS1H102KC	CAP , CHIP	
C2908	CCUS1H102KC	CAP , CHIP	
C2909	CCUS1H561JA	CAP , CHIP	
C2910	CCUS1H561JA	CAP , CHIP	
C2911	CCUS1H182KC	CAP , CHIP(1800PF/50V/1608/X7R)	
C2912	CCUS1H182KC	CAP , CHIP(1800PF/50V/1608/X7R)	
C2915	CCUS1H561JA	CAP , CHIP	
C2916	CCUS1H561JA	CAP , CHIP	
C2917	CCUS1H104KC	CAP , CHIP	
C2918	CCUS1H104KC	CAP , CHIP	
C2921	CCUS1H152KC	CAP , CHIP	
C2922	CCUS1H152KC	CAP , CHIP	
C2925	CCUS1H102KC	CAP , CHIP	
C2926	CCUS1H102KC	CAP , CHIP	
C2927	CCUS1H102KC	CAP , CHIP	
C2928	CCUS1H102KC	CAP , CHIP	
C2929	CCUS1H561JA	CAP , CHIP	
C2930	CCUS1H561JA	CAP , CHIP	
C2931	CCUS1H182KC	CAP , CHIP(1800PF/50V/1608/X7R)	
C2932	CCUS1H182KC	CAP , CHIP(1800PF/50V/1608/X7R)	
C2935	CCUS1H561JA	CAP , CHIP	
C2936	CCUS1H561JA	CAP , CHIP	
C2937	CCUS1H104KC	CAP , CHIP	
C2938	CCUS1H104KC	CAP , CHIP	
C2951	CCUS1H152KC	CAP , CHIP	
C2952	CCUS1H152KC	CAP , CHIP	
C2955	CCUS1H102KC	CAP , CHIP	
C2956	CCUS1H102KC	CAP , CHIP	
C2957	CCUS1H102KC	CAP , CHIP	
C2958	CCUS1H102KC	CAP , CHIP	
C2959	CCUS1H561JA	CAP , CHIP	
C2960	CCUS1H561JA	CAP , CHIP	
C2961	CCUS1H182KC	CAP , CHIP(1800PF/50V/1608/X7R)	
C2962	CCUS1H182KC	CAP , CHIP(1800PF/50V/1608/X7R)	
C2965	CCUS1H561JA	CAP , CHIP	
C2966	CCUS1H561JA	CAP , CHIP	

LOAD No.	PARTS No.	DESCRIPTION	SPECIATION
C2967	CCUS1H104KC	CAP , CHIP	
C2968	CCUS1H104KC	CAP , CHIP	
C2971	CCUS1H152KC	CAP , CHIP	
C2972	CCUS1H152KC	CAP , CHIP	
C2975	CCUS1H102KC	CAP , CHIP	
C2976	CCUS1H102KC	CAP , CHIP	
C2977	CCUS1H102KC	CAP , CHIP	
C2978	CCUS1H102KC	CAP , CHIP	
C2979	CCUS1H561JA	CAP , CHIP	
C2980	CCUS1H561JA	CAP , CHIP	
C2981	CCUS1H182KC	CAP , CHIP(1800PF/50V/1608/X7R)	
C2982	CCUS1H182KC	CAP , CHIP(1800PF/50V/1608/X7R)	
C2985	CCUS1H561JA	CAP , CHIP	
C2986	CCUS1H561JA	CAP , CHIP	
C2987	CCUS1H104KC	CAP , CHIP	
C2988	CCUS1H104KC	CAP , CHIP	
D2011	CVD1SS355T	DIODE , CHIP	
D2511	HVD1SR159-200	DIODE , RECTIFIER	
D2512	HVD1SR159-200	DIODE , RECTIFIER	
IC201	CVIANAM1421AT	I.C , U-COM T747 (T5CC1/TOSHIBA)	
IC201	CVIT5CC1	I.C , FLASH U-COM	
IC202	CVIM24C32WMN6TP	I.C , EEPROM (32 Kbit)	
IC203	HVIRH5VT18C	I.C , RESET	
IC204	HVITC74HCT7007F	I.C	
IC205	CVIXR20M1170IG16	I.C , I2C/SPI UART((16 PIN TSSOP)	
IC206	CVIXR20M1170IG16	I.C , I2C/SPI UART((16 PIN TSSOP)	
IC207	HVI74LCX08MX	I.C , AND GATE(QUAD/2IN L/V)	
IC208	HVI74LCX08MX	I.C , AND GATE(QUAD/2IN L/V)	
IC210	CVIKIA1117S33	I.C , REGULATOR(SOT-223)	
IC240	CVICS497004CQZ	I.C , DSP	
IC241	CVITC74VCX541FT	I.C , OCTAL BUS BUFFER	
IC250	CVIST25VF080B504CS2	I.C , 8 Mbit SPI Serial Flash	
IC251	HVINJM2391DL133	I.C , CHIP REGULATOR (+3.3V)	
IC252	CVIKIA1117S18	I.C , REGULATOR(SOT-223)	
IC260	CVIM12L16161A5TG	I.C , 16MB SDRAM	
IC280	HVICS42528-CQ	I.C , CODEC + DIR	
IC281	HVI74HCU04AFNG	I.C , INVERTER	
IC282	HVITC74VHC157FT	I.C , 2-CHANNEL MUX	
IC291	HVINJM2068MDTE1	I.C , OP AMP	
IC292	HVINJM2068MDTE1	I.C , OP AMP	
IC293	HVINJM2068MDTE1	I.C , OP AMP	
IC294	HVINJM2068MDTE1	I.C , OP AMP	
L2101	CLZ9R005Z	FERRITE , CHIP BEAD(60ohm, 1608)	
L2431	CLZ9R005Z	FERRITE , CHIP BEAD(60ohm, 1608)	
L2501	CLZ9Z014Z	FERRITE , CHIP BEAD(60ohm, 4516)	
L2507	CLZ9Z014Z	FERRITE , CHIP BEAD(60ohm, 4516)	
L2513	CLZ9Z014Z	FERRITE , CHIP BEAD(60ohm, 4516)	
Q2008	HVTKRC102S	T.R , CHIP	
Q2011	HVTKRA102S	T.R , CHIP	
Q2025	HVTKRC102S	T.R , CHIP	
Q2028	HVTKRC102S	T.R , CHIP	
Q2107	HVTKRA102S	T.R , CHIP	
Q2108	HVTKRC102S	T.R , CHIP	
Q2461	HVTKRC102S	T.R , CHIP	
RN201	CRJ104DJ103T	RES , ARRAY, 10K (1608)	
RN202	CRJ104DJ103T	RES , ARRAY, 10K (1608)	
RN211	CRJ104DJ101T	RES , CHIP NETWORK(1/16W, 100ohm, 1608X4)	
RN212	CRJ104DJ101T	RES , CHIP NETWORK(1/16W, 100ohm, 1608X4)	

LOAD No.	PARTS No.	DESCRIPTION	SPECIATION
RN213	CRJ104DJ101T	RES , CHIP NETWORK(1/16W, 100ohm, 1608X4)	
RN214	CRJ104DJ101T	RES , CHIP NETWORK(1/16W, 100ohm, 1608X4)	
RN215	CRJ104DJ101T	RES , CHIP NETWORK(1/16W, 100ohm, 1608X4)	
RN216	CRJ104DJ103T	RES, ARRAY, 10K (1608)	
RN217	CRJ104DJ103T	RES, ARRAY, 10K (1608)	
RN241	CRJ104DJ103T	RES, ARRAY, 10K (1608)	
RN242	CRJ104DJ330T	RES , 4ARRAY (1608*4)	
RN243	CRJ104DJ330T	RES , 4ARRAY (1608*4)	
RN244	CRJ104DJ330T	RES , 4ARRAY (1608*4)	
RN245	CRJ104DJ330T	RES , 4ARRAY (1608*4)	
RN246	CRJ104DJ330T	RES , 4ARRAY (1608*4)	
RN247	CRJ104DJ330T	RES , 4ARRAY (1608*4)	
RN248	CRJ104DJ330T	RES , 4ARRAY (1608*4)	
RN249	CRJ104DJ330T	RES , 4ARRAY (1608*4)	
RN250	CRJ104DJ330T	RES , 4ARRAY (1608*4)	
RN251	CRJ104DJ330T	RES , 4ARRAY (1608*4)	
RN252	CRJ104DJ330T	RES , 4ARRAY (1608*4)	
RN253	CRJ104DJ330T	RES , 4ARRAY (1608*4)	
RN254	CRJ104DJ103T	RES, ARRAY, 10K (1608)	
RN255	CRJ104DJ103T	RES, ARRAY, 10K (1608)	
RN256	CRJ104DJ103T	RES, ARRAY, 10K (1608)	
RN257	CRJ104DJ330T	RES , 4ARRAY (1608*4)	
RN258	CRJ104DJ330T	RES , 4ARRAY (1608*4)	
R2001	CRJ10DJ103T	RES , CHIP	
R2003	CRJ10DJ471T	RES , CHIP	
R2007	CRJ10DJ102T	RES , CHIP	
R2008	CRJ10DJ103T	RES , CHIP	
R2009	CRJ10DJ153T	RES , CHIP	
R2012	CRJ10DJ101T	RES , CHIP	
R2013	CRJ10DJ101T	RES , CHIP	
R2014	CRJ10DJ101T	RES , CHIP	
R2015	CRJ10DJ101T	RES , CHIP	
R2016	CRJ10DJ101T	RES , CHIP	
R2017	CRJ10DJ101T	RES , CHIP	
R2019	CRJ10DJ103T	RES , CHIP	
R2022	CRJ10DJ272T	RES , CHIP	
R2023	CRJ10DJ272T	RES , CHIP	
R2024	CRJ10DJ473T	RES , CHIP	
R2025	CRJ10DJ103T	RES , CHIP	
R2027	CRJ10DJ103T	RES , CHIP	
R2028	CRJ10DJ103T	RES , CHIP	
R2035	CRJ10DJ0R0T	RES , CHIP	
R2041	CRJ10DJ103T	RES , CHIP	
R2042	CRJ10DJ101T	RES , CHIP	
R2046	CRJ10DJ4R7T	RES , CHIP	
R2049	CRJ10DJ0R0T	RES , CHIP	
R2050	CRJ10DJ0R0T	RES , CHIP	
R2051	CRJ10DJ101T	RES , CHIP	
R2052	CRJ10DJ101T	RES , CHIP	
R2053	CRJ10DJ101T	RES , CHIP	
R2054	CRJ10DJ101T	RES , CHIP	
R2055	CRJ10DJ105T	RES , CHIP	
R2056	CRJ10DJ471T	RES , CHIP	
R2057	CRJ10DJ103T	RES , CHIP	
R2058	CRJ10DJ103T	RES , CHIP	
R2059	CRJ10DJ101T	RES , CHIP	
R2060	CRJ10DJ101T	RES , CHIP	
R2061	CRJ10DJ4R7T	RES , CHIP	

LOAD No.	PARTS No.	DESCRIPTION	SPECIATION
R2071	CRJ10DJ101T	RES , CHIP	
R2072	CRJ10DJ101T	RES , CHIP	
R2073	CRJ10DJ101T	RES , CHIP	
R2074	CRJ10DJ102T	RES , CHIP	
R2075	CRJ10DJ105T	RES , CHIP	
R2076	CRJ10DJ471T	RES , CHIP	
R2077	CRJ10DJ103T	RES , CHIP	
R2078	CRJ10DJ103T	RES , CHIP	
R2079	CRJ10DJ4R7T	RES , CHIP	
R2080	CRJ10DJ101T	RES , CHIP	
R2081	CRJ10DJ101T	RES , CHIP	
R2082	CRJ10DJ101T	RES , CHIP	
R2084	CRJ10DJ101T	RES , CHIP	
R2085	CRJ10DJ101T	RES , CHIP	
R2086	CRJ10DJ153T	RES , CHIP	
R2087	CRJ10DJ101T	RES , CHIP	
R2088	CRJ10DJ4R7T	RES , CHIP	
R2089	CRJ10DJ101T	RES , CHIP	
R2091	CRJ10DJ102T	RES , CHIP	
R2092	CRJ10DJ102T	RES , CHIP	
R2093	CRJ10DJ102T	RES , CHIP	
R2094	CRJ10DJ4R7T	RES , CHIP	
R2097	CRJ10DJ0R0T	RES , CHIP	
R2106	CRJ10DJ4R7T	RES , CHIP	
R2108	CRJ10DJ103T	RES , CHIP	
R2111	CRJ10DJ0R0T	RES , CHIP	
R2122	CRJ10DJ101T	RES , CHIP	
R2123	CRJ10DJ101T	RES , CHIP	
R2134	CRJ10DJ101T	RES , CHIP	
R2135	CRJ10DJ101T	RES , CHIP	
R2136	CRJ10DJ101T	RES , CHIP	
R2137	CRJ10DJ101T	RES , CHIP	
R2139	CRJ10DJ0R0T	RES , CHIP	
R2141	CRJ10DJ0R0T	RES , CHIP	
R2142	CRJ10DJ0R0T	RES , CHIP	
R2401	CRJ10DJ103T	RES , CHIP	
R2402	CRJ10DJ101T	RES , CHIP	
R2403	CRJ10DJ330T	RES , CHIP	
R2404	CRJ10DJ330T	RES , CHIP	
R2405	CRJ10DJ103T	RES , CHIP	
R2406	CRJ10DJ103T	RES , CHIP	
R2407	CRJ10DJ330T	RES , CHIP	
R2408	CRJ10DJ330T	RES , CHIP	
R2409	CRJ10DJ330T	RES , CHIP	
R2412	CRJ10DJ330T	RES , CHIP	
R2413	CRJ10DJ103T	RES , CHIP	
R2414	CRJ10DJ101T	RES , CHIP	
R2415	CRJ10DJ103T	RES , CHIP	
R2416	CRJ10DJ332T	RES , CHIP	
R2417	CRJ10DJ332T	RES , CHIP	
R2418	CRJ10DJ332T	RES , CHIP	
R2419	CRJ10DJ332T	RES , CHIP	
R2420	CRJ10DJ332T	RES , CHIP	
R2421	CRJ10DJ332T	RES , CHIP	
R2423	CRJ10DJ103T	RES , CHIP	
R2424	CRJ10DJ103T	RES , CHIP	
R2425	CRJ10DJ471T	RES , CHIP	
R2426	CRJ10DJ105T	RES , CHIP	

LOAD No.	PARTS No.	DESCRIPTION	SPECIATION
R2433	CRJ10DJ0R0T	RES , CHIP	
R2434	CRJ10DF5101T	RES. CHIP (5.1K 1%)	
R2435	CRJ10DJ330T	RES , CHIP	
R2436	CRJ10DJ103T	RES , CHIP	
R2437	CRJ10DJ103T	RES , CHIP	
R2441	CRJ10DJ103T	RES , CHIP	
R2442	CRJ10DJ103T	RES , CHIP	
R2461	CRJ10DJ103T	RES , CHIP	
R2463	CRJ10DJ330T	RES , CHIP	
R2464	CRJ10DJ101T	RES , CHIP	
R2465	CRJ10DJ330T	RES , CHIP	
R2466	CRJ10DJ330T	RES , CHIP	
R2467	CRJ10DJ330T	RES , CHIP	
R2468	CRJ10DJ330T	RES , CHIP	
R2469	CRJ10DJ330T	RES , CHIP	
R2591	CRJ10DJ4R7T	RES , CHIP	
R2592	CRJ10DJ4R7T	RES , CHIP	
R2593	CRJ10DJ4R7T	RES , CHIP	
R2594	CRJ10DJ4R7T	RES , CHIP	
R2595	CRJ10DJ4R7T	RES , CHIP	
R2596	CRJ10DJ4R7T	RES , CHIP	
R2597	CRJ10DJ4R7T	RES , CHIP	
R2562	CRJ10DJ102T	RES , CHIP	
R2801	CRJ10DJ103T	RES , CHIP	
R2803	CRJ10DJ103T	RES , CHIP	
R2804	CRJ10DJ103T	RES , CHIP	
R2805	CRJ10DJ0R0T	RES , CHIP	
R2806	CRJ10DJ0R0T	RES , CHIP	
R2809	CRJ10DJ102T	RES , CHIP	
R2810	CRJ10DJ101T	RES , CHIP	
R2817	CRJ10DJ104T	RES , CHIP	
R2819	CRJ10DJ0R0T	RES , CHIP	
R2820	CRJ10DJ332T	RES , CHIP	
R2822	CRJ10DJ0R0T	RES , CHIP	
R2828	CRJ10DJ100T	RES , CHIP	
R2829	CRJ10DJ0R0T	RES , CHIP	
R2832	CRJ10DJ560T	RES , CHIP	
R2833	CRJ10DJ101T	RES , CHIP	
R2834	CRJ10DJ102T	RES , CHIP	
R2835	CRJ10DJ102T	RES , CHIP	
R2836	CRJ10DJ101T	RES , CHIP	
R2841	CRJ10DJ0R0T	RES , CHIP	
R2843	CRJ10DJ330T	RES , CHIP	
R2844	CRJ10DJ104T	RES , CHIP	
R2846	CRJ10DJ472T	RES , CHIP	
R2847	CRJ10DJ104T	RES , CHIP	
R2848	CRJ10DJ472T	RES , CHIP	
R2851	CRJ10DJ100T	RES , CHIP	
R2852	CRJ10DJ241T	RES , CHIP	
R2853	CRJ10DJ750T	RES , CHIP	
R2854	CRJ10DJ750T	RES , CHIP	
R2858	CRJ10DJ750T	RES , CHIP	
R2859	CRJ10DJ101T	RES , CHIP	
R2861	CRJ10DJ103T	RES , CHIP	
R2862	CRJ10DJ103T	RES , CHIP	
R2863	CRJ10DJ103T	RES , CHIP	
R2901	CRJ10DJ122T	RES , CHIP	
R2902	CRJ10DJ122T	RES , CHIP	

ONLY C VERSION

LOAD No.	PARTS No.	DESCRIPTION	SPECIATION
R2903	CRJ10DJ122T	RES , CHIP	
R2904	CRJ10DJ122T	RES , CHIP	
R2905	CRJ10DJ152T	RES , CHIP	
R2906	CRJ10DJ152T	RES , CHIP	
R2907	CRJ10DJ152T	RES , CHIP	
R2908	CRJ10DJ152T	RES , CHIP	
R2909	CRJ10DJ122T	RES , CHIP	
R2910	CRJ10DJ122T	RES , CHIP	
R2911	CRJ10DJ512T	RES , CHIP	
R2912	CRJ10DJ512T	RES , CHIP	
R2913	CRJ10DJ512T	RES , CHIP	
R2914	CRJ10DJ512T	RES , CHIP	
R2915	CRJ10DJ122T	RES , CHIP	
R2916	CRJ10DJ122T	RES , CHIP	
R2918	CRJ10DJ104T	RES , CHIP	
R2921	CRJ10DJ122T	RES , CHIP	
R2922	CRJ10DJ122T	RES , CHIP	
R2923	CRJ10DJ122T	RES , CHIP	
R2924	CRJ10DJ122T	RES , CHIP	
R2925	CRJ10DJ152T	RES , CHIP	
R2926	CRJ10DJ152T	RES , CHIP	
R2927	CRJ10DJ152T	RES , CHIP	
R2928	CRJ10DJ152T	RES , CHIP	
R2929	CRJ10DJ122T	RES , CHIP	
R2930	CRJ10DJ122T	RES , CHIP	
R2931	CRJ10DJ512T	RES , CHIP	
R2932	CRJ10DJ103T	RES , CHIP	
R2933	CRJ10DJ512T	RES , CHIP	
R2934	CRJ10DJ103T	RES , CHIP	
R2935	CRJ10DJ122T	RES , CHIP	
R2936	CRJ10DJ122T	RES , CHIP	
R2937	CRJ10DJ104T	RES , CHIP	
R2938	CRJ10DJ104T	RES , CHIP	
R2951	CRJ10DJ122T	RES , CHIP	
R2952	CRJ10DJ122T	RES , CHIP	
R2953	CRJ10DJ122T	RES , CHIP	
R2954	CRJ10DJ122T	RES , CHIP	
R2955	CRJ10DJ152T	RES , CHIP	
R2956	CRJ10DJ152T	RES , CHIP	
R2957	CRJ10DJ152T	RES , CHIP	
R2958	CRJ10DJ152T	RES , CHIP	
R2959	CRJ10DJ122T	RES , CHIP	
R2960	CRJ10DJ122T	RES , CHIP	
R2961	CRJ10DJ512T	RES , CHIP	
R2962	CRJ10DJ512T	RES , CHIP	
R2963	CRJ10DJ512T	RES , CHIP	
R2964	CRJ10DJ512T	RES , CHIP	
R2965	CRJ10DJ122T	RES , CHIP	
R2966	CRJ10DJ122T	RES , CHIP	
R2967	CRJ10DJ104T	RES , CHIP	
R2968	CRJ10DJ104T	RES , CHIP	
R2971	CRJ10DJ122T	RES , CHIP	
R2972	CRJ10DJ122T	RES , CHIP	
R2973	CRJ10DJ122T	RES , CHIP	
R2974	CRJ10DJ122T	RES , CHIP	
R2975	CRJ10DJ152T	RES , CHIP	
R2976	CRJ10DJ152T	RES , CHIP	
R2977	CRJ10DJ152T	RES , CHIP	

LOAD No.	PARTS No.	DESCRIPTION	SPECIATION
R2978	CRJ10DJ152T	RES , CHIP	
R2979	CRJ10DJ122T	RES , CHIP	
R2980	CRJ10DJ122T	RES , CHIP	
R2981	CRJ10DJ512T	RES , CHIP	
R2982	CRJ10DJ512T	RES , CHIP	
R2983	CRJ10DJ512T	RES , CHIP	
R2984	CRJ10DJ512T	RES , CHIP	
R2985	CRJ10DJ122T	RES , CHIP	
R2986	CRJ10DJ122T	RES , CHIP	
R2987	CRJ10DJ104T	RES , CHIP	
R2988	CRJ10DJ104T	RES , CHIP	
R2995	CRJ10DJ0R0T	RES , CHIP	
X2003	HOX27000E180S	CRYSTAL , CHIP(27MHZ,SMD)	
X2055	COX24000E200S	CRYSTAL , CHIP(24MHZ, HC-49/SMD)	
X2075	COX24000E200S	CRYSTAL , CHIP(24MHZ, HC-49/SMD)	
	C2K86102	SOLDER , FLUX WIRE PB FREE(PIE 1.0)	
C2103	CCEA1CH101T	CAP , ELECT	
C2105	CCEA1CH101T	CAP , ELECT	
C2125	CCEA1CKS101T	CAP , ELECT	
C2126	CCEA1CKS101T	CAP , ELECT	
C2127	CCEA1CKS101T	CAP , ELECT	
C2128	CCEA1CKS101T	CAP , ELECT	
C2431	CCEA1CH101T	CAP , ELECT	
C2501	CCEA0JH102T	CAP , ELECT	
C2503	CCEA0JH102T	CAP , ELECT	
C2514	CCEA1AH471T	CAP , ELECT	
C2516	CCEA1CH101T	CAP , ELECT	
C2522	CCEA1CH101T	CAP , ELECT	
C2524	CCEA1CH101T	CAP , ELECT	
C2526	CCEA1CH101T	CAP , ELECT	
C2528	CCEA1CH101T	CAP , ELECT	
C2530	CCEA1CH101T	CAP , ELECT	
C2534	CCEA1CKS101T	CAP , ELECT	
C2536	CCEA1CH101T	CAP , ELECT	
C2542	CCEA1CKS101T	CAP , ELECT	
C2544	CCEA1CKS101T	CAP , ELECT	
C2546	CCEA1CKS101T	CAP , ELECT	
C2548	CCEA1CH101T	CAP , ELECT	
C2550	CCEA1CKS101T	CAP , ELECT	
C2552	CCEA1CKS101T	CAP , ELECT	
C2554	CCEA1CH101T	CAP , ELECT	
C2556	CCEA1CH101T	CAP , ELECT	
C2805	CCEA1CH101T	CAP , ELECT	
C2806	CCEA1CH101T	CAP , ELECT	
C2811	CCEA1HKS4R7T	CAP , ELECT	
C2812	CCEA1HKS4R7T	CAP , ELECT	
C2814	CCEA1HKS4R7T	CAP , ELECT	
C2817	CCEA1CKS101T	CAP , ELECT	
C2819	CCEA1AH471T	CAP , ELECT	
C2823	CCEA1CH101T	CAP , ELECT	
C2828	CCEA1CH101T	CAP , ELECT	
C2829	CCEA1CH101T	CAP , ELECT	
C2841	CCEA1AH471T	CAP , ELECT	
C2861	CCEA1CH101T	CAP , ELECT	
C2862	CCEA1CH101T	CAP , ELECT	
C2863	CCEA1CH101T	CAP , ELECT	
C2913	CCEA1HKS100T	CAP , ELECT	
C2914	CCEA1HKS100T	CAP , ELECT	

LOAD No.	PARTS No.	DESCRIPTION	SPECIATION
C2933	CCEA1HKS100T	CAP , ELECT	
C2934	CCEA1HKS100T	CAP , ELECT	
C2963	CCEA1HKS100T	CAP , ELECT	
C2964	CCEA1HKS100T	CAP , ELECT	
C2983	CCEA1HKS100T	CAP , ELECT	
C2984	CCEA1HKS100T	CAP , ELECT	
	C2K86002	SOLDER , BAR SN PB FREE	
	C8E534	FLUX	
BN490	CJP15GB99ZM	WAFER	
BN490	CJP15GB99ZY	WAFER	
BN491	CJP05GB99ZY	WAFER ANGLE	
BN491	CJP07GB99ZM	WAFER , ANGLE (2MM,7PIN)	
CN141	CJP15GA98ZY	WAFER	
CN142	CJP15GA98ZY	WAFER	
CN143	CJP05GA98ZY	WAFER	
CN301	CJP15GA98ZY	WAFER	
CN302	CJP15GA98ZY	WAFER	
CN303	CJP15GA98ZY	WAFER	
CN501	CJP21GA202ZY	WAFER , CARDCABLE(21P , 1.25mm , ANGLE)	
C2101	CCEA0JKR3222E	CAP , ELECT	
JK241	CJJ4S022Y	JACK , BOARD	
JK242	HJSTORX177L	MODULE , OPTICAL(RX)	
JK243	HJSTORX177L	MODULE , OPTICAL(RX)	
JK244	HJSTOTX177L	MODULE , OPTICAL(TX)	
SW201	HSH2B018Z	SW , PUSH	
SW202	HSH2B018Z	SW , PUSH	
X2427	COX24576E180TF	CRYSTAL , 24.576MHz	
	CUP12119Y	PCB , VIDEO (216*247, FR4/2)	
C1301	CCUS1H101JA	CAP , CHIP	
C1302	CCUS1H101JA	CAP , CHIP	
C1303	CCUS1H101JA	CAP , CHIP	
C1313	CCUS1H101JA	CAP , CHIP	
C1314	CCUS1H101JA	CAP , CHIP	
C1315	CCUS1H101JA	CAP , CHIP	
C1316	CCUS1H101JA	CAP , CHIP	
C1317	CCUS1H101JA	CAP , CHIP	
C1318	CCUS1H101JA	CAP , CHIP	
C1325	CCUS1H101JA	CAP , CHIP	
C1326	CCUS1H101JA	CAP , CHIP	
C1327	CCUS1H101JA	CAP , CHIP	
C1328	CCUS1H101JA	CAP , CHIP	
C1329	CCUS1H101JA	CAP , CHIP	
C1330	CCUS1H101JA	CAP , CHIP	
C1331	CCUS1H101JA	CAP , CHIP	
C1332	CCUS1H101JA	CAP , CHIP	
C1333	CCUS1H101JA	CAP , CHIP	
C1343	CCUS1H020CA	CAP , CHIP	
C1345	CCUS1H020CA	CAP , CHIP	
C1347	CCUS1H020CA	CAP , CHIP	
C1355	CCUS1H020CA	CAP , CHIP	
C1356	CCUS1H020CA	CAP , CHIP	
C1357	CCUS1H020CA	CAP , CHIP	
C1358	CCUS1H020CA	CAP , CHIP	
C1359	CCUS1H020CA	CAP , CHIP	
C1360	CCUS1H020CA	CAP , CHIP	
C1367	CCSJA1C100B	CAP , CHIP TANTAL(A TYPE, 10uF/16V, ELNA)	
C1368	CCUS1H104KC	CAP , CHIP	
C1369	CCSJA1C100B	CAP , CHIP TANTAL(A TYPE, 10uF/16V, ELNA)	

LOAD No.	PARTS No.	DESCRIPTION	SPECIATION
C1370	CCUS1H104KC	CAP , CHIP	
C1376	CCUS1H104KC	CAP , CHIP	
C1390	CCUS1H104KC	CAP , CHIP	
C1398	CCSJA1C100B	CAP , CHIP TANTAL(A TYPE, 10uF/16V, ELNA)	
C1399	CCSJA1C100B	CAP , CHIP TANTAL(A TYPE, 10uF/16V, ELNA)	
C1400	CCSJA1C100B	CAP , CHIP TANTAL(A TYPE, 10uF/16V, ELNA)	
C1401	CCSJA1C100B	CAP , CHIP TANTAL(A TYPE, 10uF/16V, ELNA)	
C1402	CCSJA1C100B	CAP , CHIP TANTAL(A TYPE, 10uF/16V, ELNA)	
C1403	CCSJA1C100B	CAP , CHIP TANTAL(A TYPE, 10uF/16V, ELNA)	
C1404	CCSJA1C100B	CAP , CHIP TANTAL(A TYPE, 10uF/16V, ELNA)	
C1405	CCSJA1C100B	CAP , CHIP TANTAL(A TYPE, 10uF/16V, ELNA)	
C1406	CCUS1H104KC	CAP , CHIP	
C1407	CCUS1H104KC	CAP , CHIP	
C1408	CCUS1H104KC	CAP , CHIP	
C1409	CCUS1H104KC	CAP , CHIP	
C1410	CCUS1H104KC	CAP , CHIP	
C1411	CCUS1H104KC	CAP , CHIP	
IC131	CVINJW1321FP1	I.C , VIDEO S/W	
IC133	HVINJM2581MTE1	I.C	
IC134	HVINJM2285MTE1	I.C, VIDEO SWITCH	
IC135	HVINJM2586AMTE1	I.C , VIDEO SW	
L1301	CLZ9Z014Z	FERRITE , CHIP BEAD(60ohm, 4516)	
L1302	CLZ9Z014Z	FERRITE , CHIP BEAD(60ohm, 4516)	
L1303	CLZ9R005Z	FERRITE , CHIP BEAD(60ohm, 1608)	
R1301	CRJ10DJ750T	RES , CHIP	
R1302	CRJ10DJ750T	RES , CHIP	
R1303	CRJ10DJ750T	RES , CHIP	
R1304	CRJ10DJ0R0T	RES , CHIP	
R1305	CRJ10DJ0R0T	RES , CHIP	
R1306	CRJ10DJ0R0T	RES , CHIP	
R1307	CRJ10DJ750T	RES , CHIP	
R1308	CRJ10DJ750T	RES , CHIP	
R1309	CRJ10DJ750T	RES , CHIP	
R1310	CRJ10DJ750T	RES , CHIP	
R1311	CRJ10DJ750T	RES , CHIP	
R1312	CRJ10DJ750T	RES , CHIP	
R1313	CRJ10DJ750T	RES , CHIP	
R1314	CRJ10DJ750T	RES , CHIP	
R1315	CRJ10DJ750T	RES , CHIP	
R1316	CRJ10DJ750T	RES , CHIP	
R1317	CRJ10DJ750T	RES , CHIP	
R1318	CRJ10DJ750T	RES , CHIP	
R1319	CRJ10DJ750T	RES , CHIP	
R1320	CRJ10DJ750T	RES , CHIP	
R1321	CRJ10DJ750T	RES , CHIP	
R1322	CRJ10DJ0R0T	RES , CHIP	
R1323	CRJ10DJ0R0T	RES , CHIP	
R1324	CRJ10DJ0R0T	RES , CHIP	
R1325	CRJ10DJ750T	RES , CHIP	
R1326	CRJ10DJ750T	RES , CHIP	
R1327	CRJ10DJ750T	RES , CHIP	
R1328	CRJ10DJ750T	RES , CHIP	
R1329	CRJ10DJ750T	RES , CHIP	
R1330	CRJ10DJ750T	RES , CHIP	
R1331	CRJ10DJ750T	RES , CHIP	
R1332	CRJ10DJ750T	RES , CHIP	
R1333	CRJ10DJ750T	RES , CHIP	
R1334	CRJ10DJ4R7T	RES , CHIP	

LOAD No.	PARTS No.	DESCRIPTION	SPECIATION
R1335	CRJ10DJ4R7T	RES , CHIP	
R1338	CRJ10DJ4R7T	RES , CHIP	
R1339	CRJ10DJ4R7T	RES , CHIP	
R1342	CRJ10DJ4R7T	RES , CHIP	
R1343	CRJ10DJ4R7T	RES , CHIP	
R1344	CRJ10DJ103T	RES , CHIP	
C1304	CCEA1HH100T	CAP , ELECT	
C1305	CCEA1HH100T	CAP , ELECT	
C1306	CCEA1HH100T	CAP , ELECT	
C1310	CCEA1AH471T	CAP , ELECT	
C1311	CCEA1AH471T	CAP , ELECT	
C1312	CCEA1AH471T	CAP , ELECT	
C1319	CCEA1HH100T	CAP , ELECT	
C1320	CCEA1HH100T	CAP , ELECT	
C1321	CCEA1HH100T	CAP , ELECT	
C1322	CCEA1AH471T	CAP , ELECT	
C1323	CCEA1AH471T	CAP , ELECT	
C1324	CCEA1AH471T	CAP , ELECT	
C1334	CCEA1HH100T	CAP , ELECT	
C1335	CCEA1HH100T	CAP , ELECT	
C1336	CCEA1HH100T	CAP , ELECT	
C1337	CCEA1HH100T	CAP , ELECT	
C1338	CCEA1HH100T	CAP , ELECT	
C1339	CCEA1HH100T	CAP , ELECT	
C1340	CCEA1AH101T	CAP , ELECT	
C1341	CCEA1AH101T	CAP , ELECT	
C1342	CCEA1AH101T	CAP , ELECT	
C1349	CCEA1HH100T	CAP , ELECT	
C1350	CCEA1CH471T	CAP , ELECT	
C1351	CCEA1HH100T	CAP , ELECT	
C1352	CCEA1CH471T	CAP , ELECT	
C1353	CCEA1HH100T	CAP , ELECT	
C1354	CCEA1CH471T	CAP , ELECT	
C1361	CCEA1HH100T	CAP , ELECT	
C1362	CCEA1HH100T	CAP , ELECT	
C1363	CCEA1HH100T	CAP , ELECT	
C1364	CCEA1HH100T	CAP , ELECT	
C1365	CCEA1HH100T	CAP , ELECT	
C1366	CCEA1HH100T	CAP , ELECT	
C1375	CCEA1HH100T	CAP , ELECT	
C1377	CCEA1HH1R0T	CAP , ELECT	
C1378	CCEA1HH1R0T	CAP , ELECT	
C1379	CCEA1HH1R0T	CAP , ELECT	
C1380	CCEA1HH1R0T	CAP , ELECT	
C1381	CCEA1HH1R0T	CAP , ELECT	
C1382	CCEA1HH1R0T	CAP , ELECT	
C1383	CCEA1HH1R0T	CAP , ELECT	
C1384	CCEA1HH1R0T	CAP , ELECT	
C1385	CCEA1HH1R0T	CAP , ELECT	
C1386	CCEA1HH1R0T	CAP , ELECT	
C1387	CCEA1HH1R0T	CAP , ELECT	
C1388	CCEA1HH1R0T	CAP , ELECT	
C1389	CCEA1HH100T	CAP , ELECT	
C1391	CCEA1CH101T	CAP , ELECT	
C1392	CCEA1HH1R0T	CAP , ELECT	
C1393	CCEA1HH1R0T	CAP , ELECT	
C1394	CCEA1HH1R0T	CAP , ELECT	
BK131	CMD1A569	BRACKET , PCB	

LOAD No.	PARTS No.	DESCRIPTION	SPECIATION
CN131	CJP17GA115ZY	WAFER , CARDCABLE	
CN132	CJP17GA115ZY	WAFER , CARDCABLE	
CN133	CJP05GI236ZW	LOCKING TYPE , STRAIGHT WAFER , 2mm	
CN134	CJP09GI236ZW	LOCKING TYPE , STRAIGHT WAFER , 2MM	
CN135	CJP09GI236ZW	LOCKING TYPE , STRAIGHT WAFER , 2MM	
JK131	CJJ9P004Z	JACK , RCA/DIN (2P, 220A, YLx2, S-VHSx2, AU PL)	
JK132	CJJ9P004Z	JACK , RCA/DIN (2P, 220A, YLx2, S-VHSx2, AU PL)	
JK133	CJJ9R002Z	JACK , RCA/DIN (3P, 304A, YLx3, S-VHSx3, AU PL)	
JK134	CJJ4R046Z	JACK , BOARD	
JK135	CJJ4R046Z	JACK , BOARD	
	CUP12118Y	PCB , INPUT T747AH (300X194,FR4/2)	
C3001	CCUS1H221JA	CAP , CHIP	
C3002	CCUS1H221JA	CAP , CHIP	
C3003	CCUS1H221JA	CAP , CHIP	
C3004	CCUS1H221JA	CAP , CHIP	
C3005	CCUS1H221JA	CAP , CHIP	
C3006	CCUS1H221JA	CAP , CHIP	
C3007	CCUS1H221JA	CAP , CHIP	
C3008	CCUS1H221JA	CAP , CHIP	
C3009	CCUS1H221JA	CAP , CHIP	
C3010	CCUS1H221JA	CAP , CHIP	
C3011	CCUS1H221JA	CAP , CHIP	
C3012	CCUS1H221JA	CAP , CHIP	
C3013	CCUS1H221JA	CAP , CHIP	
C3014	CCUS1H221JA	CAP , CHIP	
C3015	CCUS1H221JA	CAP , CHIP	
C3016	CCUS1H221JA	CAP , CHIP	
C3017	CCUS1H221JA	CAP , CHIP	
C3018	CCUS1H221JA	CAP , CHIP	
C3019	CCUS1H221JA	CAP , CHIP	
C3020	CCUS1H221JA	CAP , CHIP	
C3021	CCUS1H221JA	CAP , CHIP	
C3022	CCUS1H221JA	CAP , CHIP	
C3023	CCUS1H221JA	CAP , CHIP	
C3024	CCUS1H221JA	CAP , CHIP	
C3025	CCUS1H221JA	CAP , CHIP	
C3026	CCUS1H221JA	CAP , CHIP	
C3103	CCUS1H223KC	CAP , CHIP	
C3104	CCUS1H103KC	CAP , CHIP	
C3106	CCUS1H223KC	CAP , CHIP	
C3111	CCUS1H221JA	CAP , CHIP	
C3112	CCUS1H221JA	CAP , CHIP	
C3113	CCUS1H221JA	CAP , CHIP	
C3114	CCUS1H221JA	CAP , CHIP	
C3115	CCUS1H221JA	CAP , CHIP	
C3116	CCUS1H221JA	CAP , CHIP	
C3117	CCUS1H221JA	CAP , CHIP	
C3118	CCUS1H221JA	CAP , CHIP	
C3203	CCUS1H223KC	CAP , CHIP	
C3204	CCUS1H223KC	CAP , CHIP	
C3211	CCUS1H151JA	CAP , CHIP	
C3212	CCUS1H151JA	CAP , CHIP	
C3223	CCUS1H223KC	CAP , CHIP	
C3224	CCUS1H223KC	CAP , CHIP	
C3323	CCUS1H473KC	CAP , CHIP	
C3324	CCUS1H473KC	CAP , CHIP	
C3332	CCUS1H104KC	CAP , CHIP	
C3333	CCUS1H470JA	CAP , CHIP	

LOAD No.	PARTS No.	DESCRIPTION	SPECIATION
C3334	CCUS1H470JA	CAP , CHIP	
C3335	CCUS1H470JA	CAP , CHIP	
C3401	CCUS1H102KC	CAP , CHIP	ONLY AH VERSION
C3402	CCUS1H104KC	CAP , CHIP	ONLY AH VERSION
C3403	CCUS1H104KC	CAP , CHIP	ONLY AH VERSION
C3404	CCUS1H104KC	CAP , CHIP	ONLY AH VERSION
C3406	CCUS1H104KC	CAP , CHIP	ONLY AH VERSION
C3407	CCUS1H104KC	CAP , CHIP	ONLY AH VERSION
C3408	CCUS1H181JA	CAP , CHIP	ONLY AH VERSION
C3409	CCUS1H104KC	CAP , CHIP	ONLY AH VERSION
C3410	CCUS1H104KC	CAP , CHIP	ONLY AH VERSION
C3411	CCUS1H180JA	CAP , CHIP(18PF/50V)	ONLY AH VERSION
C3412	CCUS1H180JA	CAP , CHIP(18PF/50V)	ONLY AH VERSION
C3413	CCUS1H102KC	CAP , CHIP	ONLY AH VERSION
C3414	CCUS1H104KC	CAP , CHIP	ONLY AH VERSION
C3415	CCUS1H104KC	CAP , CHIP	ONLY AH VERSION
C3416	CCUS1H102KC	CAP , CHIP	ONLY AH VERSION
C3417	CCUS1H102KC	CAP , CHIP	ONLY AH VERSION
C3419	CCUS1H104KC	CAP , CHIP	ONLY AH VERSION
C3420	CCUS1H104KC	CAP , CHIP	ONLY AH VERSION
C3421	CCUS1H104KC	CAP , CHIP	ONLY AH VERSION
C3422	CCUS1H220JA	CAP , CHIP	ONLY AH VERSION
C3423	CCUS1H220JA	CAP , CHIP	ONLY AH VERSION
C3425	CCUS1H104KC	CAP , CHIP	ONLY AH VERSION
C3426	CCUS1H104KC	CAP , CHIP	ONLY AH VERSION
C3428	CCUS1H104KC	CAP , CHIP	ONLY AH VERSION
C3431	CCUS1H104KC	CAP , CHIP	ONLY AH VERSION
C3441	CCUS1H104KC	CAP , CHIP	ONLY AH VERSION
C3445	CCUS1H104KC	CAP , CHIP	ONLY AH VERSION
C3453	CCUS1H102KC	CAP , CHIP	ONLY AH VERSION
C3454	CCUS1H102KC	CAP , CHIP	ONLY AH VERSION
C3455	CCUS1H152KC	CAP , CHIP	ONLY AH VERSION
C3456	CCUS1H152KC	CAP , CHIP	ONLY AH VERSION
C3459	CCUS1H101JA	CAP , CHIP	ONLY AH VERSION
C3460	CCUS1H101JA	CAP , CHIP	ONLY AH VERSION
C3463	CCUS1H223KC	CAP , CHIP	ONLY AH VERSION
C3464	CCUS1H223KC	CAP , CHIP	ONLY AH VERSION
C3472	CCUS1H223KC	CAP , CHIP	ONLY AH VERSION
C3474	CCUS1H223KC	CAP , CHIP	ONLY AH VERSION
C3476	CCUS1H331JA	CAP , CHIP	ONLY AH VERSION
C3477	CCUS1H104KC	CAP , CHIP	ONLY AH VERSION
C3478	CCUS1H561JA	CAP , CHIP	ONLY AH VERSION
C3479	CCUS1H104KC	CAP , CHIP	ONLY AH VERSION
C3480	CCUS1H220JA	CAP , CHIP	ONLY AH VERSION
C3481	CCUS1H220JA	CAP , CHIP	ONLY AH VERSION
C3482	CCUS1H102KC	CAP , CHIP	ONLY AH VERSION
C3483	CCUS1H102KC	CAP , CHIP	ONLY AH VERSION
C3602	CCUS1H104KC	CAP , CHIP	ONLY AH VERSION
C3604	CCUS1H104KC	CAP , CHIP	ONLY AH VERSION
C3606	CCUS1H104KC	CAP , CHIP	ONLY AH VERSION
C3608	CCUS1H104KC	CAP , CHIP	ONLY AH VERSION
C3610	CCUS1H104KC	CAP , CHIP	ONLY AH VERSION
C3612	CCUS1H104KC	CAP , CHIP	ONLY AH VERSION
C3701	CCUS1H104KC	CAP , CHIP	ONLY AH VERSION
C3703	CCUS1H104KC	CAP , CHIP	ONLY AH VERSION
C3705	CCUS1H104KC	CAP , CHIP	ONLY AH VERSION
C3708	CCUS1H104KC	CAP , CHIP	ONLY AH VERSION
C3709	CCUS1H104KC	CAP , CHIP	ONLY AH VERSION

LOAD No.	PARTS No.	DESCRIPTION	SPECIATION
C3711	CCUS1H104KC	CAP , CHIP	
C3713	CCUS1H104KC	CAP , CHIP	
C3715	CCUS1H104KC	CAP , CHIP	
C3717	CCUS1H104KC	CAP , CHIP	
C3719	CCUS1H104KC	CAP , CHIP	
C3721	CCUS1H104KC	CAP , CHIP	ONLY C VERSION
C3722	CCUS1H104KC	CAP , CHIP	ONLY C VERSION
D3110	CVD1SS355T	DIODE , CHIP	
D3327	HVDRB160L60TE25	DIODE , SCHOTTKEY BARRIER HK	
D3328	HVDRB160L60TE25	DIODE , SCHOTTKEY BARRIER HK	
D3422	HVDUDZS4.3BSR	DIODE , ZENER (CHIP,4.3V)	ONLY AH VERSION
D3423	HVDUDZS4.3BSR	DIODE , ZENER (CHIP,4.3V)	ONLY AH VERSION
D3429	HVDRB160L60TE25	DIODE , SCHOTTKEY BARRIER HK	ONLY AH VERSION
D3431	HVDRB160L60TE25	DIODE , SCHOTTKEY BARRIER HK	ONLY AH VERSION
D3701	CVD1SS355T	DIODE , CHIP	
D3702	CVD1SS355T	DIODE , CHIP	
D3703	CVD1SS355T	DIODE , CHIP	
D3704	CVD1SS355T	DIODE , CHIP	
D3705	CVD1SS355T	DIODE , CHIP	
D3706	CVD1SS355T	DIODE , CHIP	
D3707	CVD1SS355T	DIODE , CHIP	
D3708	CVD1SS355T	DIODE , CHIP	
D3709	CVD1SS355T	DIODE , CHIP	
D3710	CVD1SS355T	DIODE , CHIP	
D3711	CVD1SS355T	DIODE , CHIP	
D3712	CVD1SS355T	DIODE , CHIP	
D3713	CVD1SS355T	DIODE , CHIP	
D3714	CVD1SS355T	DIODE , CHIP	
D3715	CVD1SS355T	DIODE , CHIP	
D3716	CVD1SS355T	DIODE , CHIP	
D3717	CVD1SS355T	DIODE , CHIP	
D3718	CVD1SS355T	DIODE , CHIP	
D3719	CVD1SS355T	DIODE , CHIP	
D3720	CVD1SS355T	DIODE , CHIP	
IC301	CVIR2A15218FP	I.C , INPUT WITH 8CH VOLUME(100P QFP)	
IC302	HVICD4094BPWR	I.C , SHIFT REGISTER	
IC303	HVINJM2068MDTE1	I.C , OP AMP	
IC304	HVINJM2068MDTE1	I.C , OP AMP	
IC305	HVINJW1159M	I.C , VOLUME (2-CH)	
IC306	HVINJM2068MDTE1	I.C , OP AMP	
IC341	CVIXMDTIC	I.C , XM V3B	ONLY AH VERSION
IC342	CVIAK4384ET	I.C , ADC	ONLY AH VERSION
IC343	HVINJM2068MDTE1	I.C , OP AMP	ONLY AH VERSION
IC344	CVIKIA1117S33	I.C , REGULATOR(SOT-223)	ONLY AH VERSION
IC351	HVITC74HCT7007F	I.C	
IC352	HVILC72723M	IC , PLL (RDS)	
L3408	CLQ06E2R7KRZ	INDUCTOR , CHIP	ONLY AH VERSION
L3426	CLZ9Z014Z	FERRITE , CHIP BEAD(60ohm, 4516)	ONLY AH VERSION
L3429	CLZ9Z014Z	FERRITE , CHIP BEAD(60ohm, 4516)	ONLY AH VERSION
L3430	CLZ9Z014Z	FERRITE , CHIP BEAD(60ohm, 4516)	ONLY AH VERSION
Q3095	HVTKTC2875B	TR , CHIP	
Q3096	HVTKTC2875B	TR , CHIP	
Q3097	HVTKTC2875B	TR , CHIP	
Q3098	HVTKTC2875B	TR , CHIP	
Q3099	HVTKTC2875B	TR , CHIP	
Q3100	HVTKTC2875B	TR , CHIP	
Q3101	HVTKTC2875B	TR , CHIP	
Q3109	HVTKTC2875B	TR , CHIP	

LOAD No.	PARTS No.	DESCRIPTION	SPECIATION
Q3110	HVTKTC2875B	TR , CHIP	
Q3219	HVTKTC2875B	TR , CHIP	
Q3220	HVTKTC2875B	TR , CHIP	
Q3301	HVTKRC107S	T.R , CHIP	
Q3302	HVTKRC107S	T.R , CHIP	
Q3303	HVTKRC107S	T.R , CHIP	
Q3304	HVTKRC107S	T.R , CHIP	
Q3305	HVTKRC107S	T.R , CHIP	
Q3306	HVTKRC107S	T.R , CHIP	
Q3307	HVTKRC107S	T.R , CHIP	
Q3308	HVTKRC107S	T.R , CHIP	
Q3309	HVTKRA107S	TR, CHIP	
Q3310	HVTKRA107S	TR, CHIP	
Q3311	HVTKRA107S	TR, CHIP	
Q3312	HVTKRA107S	TR, CHIP	
RN341	CRJ104DJ101T	RES , CHIP NETWORK(1/16W, 100ohm, 1608X4)	ONLY AH VERSION
RN342	CRJ102DJ220T	RES , CHIP NETWORK 1/10W, 22ohm, J , 1608 2 ARRAY	ONLY AH VERSION
RN343	CRJ104DJ220T	RES,4ARRAY	ONLY AH VERSION
R3001	CRJ10DJ471T	RES , CHIP	
R3002	CRJ10DJ471T	RES , CHIP	
R3003	CRJ10DJ471T	RES , CHIP	
R3004	CRJ10DJ471T	RES , CHIP	
R3005	CRJ10DJ471T	RES , CHIP	
R3006	CRJ10DJ471T	RES , CHIP	
R3007	CRJ10DJ471T	RES , CHIP	
R3008	CRJ10DJ471T	RES , CHIP	
R3009	CRJ10DJ471T	RES , CHIP	
R3010	CRJ10DJ471T	RES , CHIP	
R3011	CRJ10DJ471T	RES , CHIP	
R3012	CRJ10DJ471T	RES , CHIP	
R3013	CRJ10DJ471T	RES , CHIP	
R3014	CRJ10DJ471T	RES , CHIP	
R3015	CRJ10DJ471T	RES , CHIP	
R3016	CRJ10DJ471T	RES , CHIP	
R3017	CRJ10DJ471T	RES , CHIP	
R3018	CRJ10DJ471T	RES , CHIP	
R3019	CRJ10DJ471T	RES , CHIP	
R3020	CRJ10DJ471T	RES , CHIP	
R3021	CRJ10DJ471T	RES , CHIP	
R3022	CRJ10DJ471T	RES , CHIP	
R3023	CRJ10DJ471T	RES , CHIP	
R3024	CRJ10DJ471T	RES , CHIP	
R3025	CRJ10DJ471T	RES , CHIP	
R3026	CRJ10DJ471T	RES , CHIP	
R3027	CRJ10DJ104T	RES , CHIP	
R3028	CRJ10DJ104T	RES , CHIP	
R3029	CRJ10DJ104T	RES , CHIP	
R3030	CRJ10DJ104T	RES , CHIP	
R3031	CRJ10DJ104T	RES , CHIP	
R3032	CRJ10DJ104T	RES , CHIP	
R3033	CRJ10DJ104T	RES , CHIP	
R3034	CRJ10DJ104T	RES , CHIP	
R3035	CRJ10DJ104T	RES , CHIP	
R3036	CRJ10DJ104T	RES , CHIP	
R3037	CRJ10DJ104T	RES , CHIP	
R3038	CRJ10DJ104T	RES , CHIP	
R3039	CRJ10DJ104T	RES , CHIP	
R3040	CRJ10DJ104T	RES , CHIP	

LOAD No.	PARTS No.	DESCRIPTION	SPECIATION
R3041	CRJ10DJ104T	RES , CHIP	
R3042	CRJ10DJ104T	RES , CHIP	
R3043	CRJ10DJ104T	RES , CHIP	
R3044	CRJ10DJ104T	RES , CHIP	
R3045	CRJ10DJ104T	RES , CHIP	
R3046	CRJ10DJ104T	RES , CHIP	
R3047	CRJ10DJ104T	RES , CHIP	
R3048	CRJ10DJ104T	RES , CHIP	
R3049	CRJ10DJ104T	RES , CHIP	
R3050	CRJ10DJ104T	RES , CHIP	
R3051	CRJ10DJ104T	RES , CHIP	
R3052	CRJ10DJ104T	RES , CHIP	
R3053	CRJ10DJ104T	RES , CHIP	
R3054	CRJ10DJ104T	RES , CHIP	
R3055	CRJ10DJ104T	RES , CHIP	
R3056	CRJ10DJ104T	RES , CHIP	
R3057	CRJ10DJ104T	RES , CHIP	
R3058	CRJ10DJ104T	RES , CHIP	
R3071	CRJ10DJ472T	RES , CHIP	
R3074	CRJ10DJ472T	RES , CHIP	
R3081	CRJ10DJ104T	RES , CHIP	
R3082	CRJ10DJ104T	RES , CHIP	
R3083	CRJ10DJ104T	RES , CHIP	
R3084	CRJ10DJ104T	RES , CHIP	
R3085	CRJ10DJ104T	RES , CHIP	
R3086	CRJ10DJ104T	RES , CHIP	
R3087	CRJ10DJ104T	RES , CHIP	
R3088	CRJ10DJ561T	RES , CHIP	
R3089	CRJ10DJ561T	RES , CHIP	
R3090	CRJ10DJ561T	RES , CHIP	
R3091	CRJ10DJ561T	RES , CHIP	
R3092	CRJ10DJ561T	RES , CHIP	
R3093	CRJ10DJ561T	RES , CHIP	
R3094	CRJ10DJ561T	RES , CHIP	
R3095	CRJ10DJ562T	RES , CHIP	
R3096	CRJ10DJ562T	RES , CHIP	
R3097	CRJ10DJ562T	RES , CHIP	
R3098	CRJ10DJ562T	RES , CHIP	
R3099	CRJ10DJ562T	RES , CHIP	
R3100	CRJ10DJ562T	RES , CHIP	
R3101	CRJ10DJ562T	RES , CHIP	
R3102	CRJ10DJ104T	RES , CHIP	
R3103	CRJ10DJ153T	RES , CHIP	
R3104	CRJ10DJ122T	RES , CHIP	
R3105	CRJ10DJ103T	RES , CHIP	
R3106	CRJ10DJ104T	RES , CHIP	
R3107	CRJ10DJ561T	RES , CHIP	
R3108	CRJ10DJ561T	RES , CHIP	
R3109	CRJ10DJ562T	RES , CHIP	
R3110	CRJ10DJ562T	RES , CHIP	
R3111	CRJ10DJ471T	RES , CHIP	
R3112	CRJ10DJ471T	RES , CHIP	
R3113	CRJ10DJ471T	RES , CHIP	
R3114	CRJ10DJ471T	RES , CHIP	
R3115	CRJ10DJ471T	RES , CHIP	
R3116	CRJ10DJ471T	RES , CHIP	
R3117	CRJ10DJ471T	RES , CHIP	
R3118	CRJ10DJ471T	RES , CHIP	

LOAD No.	PARTS No.	DESCRIPTION	SPECIATION
R3201	CRJ10DJ104T	RES , CHIP	
R3202	CRJ10DJ104T	RES , CHIP	
R3203	CRJ10DJ101T	RES , CHIP	
R3204	CRJ10DJ101T	RES , CHIP	
R3207	CRJ10DJ101T	RES , CHIP	
R3208	CRJ10DJ101T	RES , CHIP	
R3209	CRJ10DJ104T	RES , CHIP	
R3210	CRJ10DJ104T	RES , CHIP	
R3211	CRJ10DJ242T	RES , CHIP	
R3212	CRJ10DJ242T	RES , CHIP	
R3213	CRJ10DJ562T	RES , CHIP	
R3214	CRJ10DJ562T	RES , CHIP	
R3215	CRJ10DJ104T	RES , CHIP	
R3216	CRJ10DJ104T	RES , CHIP	
R3217	CRJ10DJ102T	RES , CHIP	
R3218	CRJ10DJ102T	RES , CHIP	
R3219	CRJ10DJ562T	RES , CHIP	
R3220	CRJ10DJ562T	RES , CHIP	
R3223	CRJ10DJ101T	RES , CHIP	
R3224	CRJ10DJ101T	RES , CHIP	
R3301	CRJ10DJ103T	RES , CHIP	
R3302	CRJ10DJ103T	RES , CHIP	
R3303	CRJ10DJ103T	RES , CHIP	
R3304	CRJ10DJ103T	RES , CHIP	
R3309	CRJ10DJ105T	RES , CHIP	
R3310	CRJ10DJ105T	RES , CHIP	
R3311	CRJ10DJ105T	RES , CHIP	
R3312	CRJ10DJ105T	RES , CHIP	
R3323	CRJ10DJ681T	RES , CHIP	
R3324	CRJ10DJ681T	RES , CHIP	
R3331	CRJ10DJ100T	RES , CHIP	
R3332	CRJ10DJ103T	RES , CHIP	
R3333	CRJ10DJ101T	RES , CHIP	
R3334	CRJ10DJ101T	RES , CHIP	
R3335	CRJ10DJ101T	RES , CHIP	
R3401	CRJ10DJ104T	RES , CHIP	ONLY AH VERSION
R3402	CRJ10DJ104T	RES , CHIP	ONLY AH VERSION
R3403	CRJ10DJ104T	RES , CHIP	ONLY AH VERSION
R3404	CRJ10DJ223T	RES , CHIP	ONLY AH VERSION
R3405	CRJ10DJ223T	RES , CHIP	ONLY AH VERSION
R3406	CRJ10DJ223T	RES , CHIP	ONLY AH VERSION
R3407	CRJ10DJ223T	RES , CHIP	ONLY AH VERSION
R3408	CRJ10DJ223T	RES , CHIP	ONLY AH VERSION
R3409	CRJ10DJ223T	RES , CHIP	ONLY AH VERSION
R3410	CRJ10DJ223T	RES , CHIP	ONLY AH VERSION
R3411	CRJ10DJ101T	RES , CHIP	ONLY AH VERSION
R3412	CRJ10DJ105T	RES , CHIP	ONLY AH VERSION
R3413	CRJ10DJ104T	RES , CHIP	ONLY AH VERSION
R3414	CRJ10DJ223T	RES , CHIP	ONLY AH VERSION
R3415	CRJ10DJ223T	RES , CHIP	ONLY AH VERSION
R3416	CRJ10DJ223T	RES , CHIP	ONLY AH VERSION
R3417	CRJ14CJ0R0T	RES , CHIP 1/4W	ONLY AH VERSION
R3418	CRJ10DJ102T	RES , CHIP	ONLY AH VERSION
R3419	CRJ10DJ102T	RES , CHIP	ONLY AH VERSION
R3420	CRJ10DJ101T	RES , CHIP	ONLY AH VERSION
R3421	CRJ10DJ101T	RES , CHIP	ONLY AH VERSION
R3431	CRJ10DJ473T	RES , CHIP	ONLY AH VERSION
R3441	CRJ10DJ103T	RES , CHIP	ONLY AH VERSION

LOAD No.	PARTS No.	DESCRIPTION	SPECIATION
R3442	CRJ10DJ103T	RES , CHIP	ONLY AH VERSION
R3443	CRJ10DJ0R0T	RES , CHIP	ONLY AH VERSION
R3444	CRJ10DJ103T	RES , CHIP	ONLY AH VERSION
R3451	CRJ10DJ104T	RES , CHIP	ONLY AH VERSION
R3452	CRJ10DJ104T	RES , CHIP	ONLY AH VERSION
R3453	CRJ10DJ332T	RES , CHIP	ONLY AH VERSION
R3454	CRJ10DJ332T	RES , CHIP	ONLY AH VERSION
R3455	CRJ10DJ222T	RES , CHIP	ONLY AH VERSION
R3456	CRJ10DJ222T	RES , CHIP	ONLY AH VERSION
R3457	CRJ10DJ332T	RES , CHIP	ONLY AH VERSION
R3458	CRJ10DJ332T	RES , CHIP	ONLY AH VERSION
R3459	CRJ10DJ332T	RES , CHIP	ONLY AH VERSION
R3460	CRJ10DJ332T	RES , CHIP	ONLY AH VERSION
R3461	CRJ10DJ104T	RES , CHIP	ONLY AH VERSION
R3462	CRJ10DJ104T	RES , CHIP	ONLY AH VERSION
R3463	CRJ10DJ101T	RES , CHIP	ONLY AH VERSION
R3464	CRJ10DJ101T	RES , CHIP	ONLY AH VERSION
R3471	CRJ10DJ4R7T	RES , CHIP	
R3473	CRJ10DJ4R7T	RES , CHIP	
R3481	CRJ10DJ103T	RES , CHIP	
R3482	CRJ10DJ102T	RES , CHIP	
R3483	CRJ10DJ102T	RES , CHIP	
R3601	CRJ10DJ473T	RES , CHIP	
R3604	CRJ10DJ103T	RES , CHIP	
R3605	CRJ10DJ103T	RES , CHIP	
R3606	CRJ10DJ153T	RES , CHIP	
R3609	CRJ10DF3300T	RES, CHIP 330 OHM/1608/1%	
R3610	CRJ10DF4700T	RES, CHIP 470 OHM/1608/1%	
R3611	CRJ10DF4700T	RES, CHIP 470 OHM/1608/1%	
R3614	CRJ10DJ473T	RES , CHIP	
R3693	CRJ10DJ0R0T	RES , CHIP	
R3695	CRJ10DJ0R0T	RES , CHIP	
R3701	CRJ10DJ4R7T	RES , CHIP	
R3703	CRJ10DJ4R7T	RES , CHIP	
R3705	CRJ10DJ4R7T	RES , CHIP	
R3707	CRJ10DJ4R7T	RES , CHIP	
R3709	CRJ10DJ4R7T	RES , CHIP	
R3711	CRJ10DJ4R7T	RES , CHIP	
R3713	CRJ10DJ4R7T	RES , CHIP	
R3715	CRJ10DJ4R7T	RES , CHIP	
R3717	CRJ10DJ0R0T	RES , CHIP	
R3719	CRJ10DJ4R7T	RES , CHIP	
R3721	CRJ10DJ4R7T	RES , CHIP	ONLY C VERSION
R3722	CRJ10DJ4R7T	RES , CHIP	ONLY C VERSION
X3401	COX45158E180S	X-TAL, 45.1584MHz (SMD)	ONLY AH VERSION
C3027	CCEA1HH100T	CAP , ELECT	
C3028	CCEA1HH100T	CAP , ELECT	
C3037	CCEA1HH100T	CAP , ELECT	
C3038	CCEA1HH100T	CAP , ELECT	
C3041	CCEA1HH100T	CAP , ELECT	
C3042	CCEA1HH100T	CAP , ELECT	
C3053	CCEA1HH100T	CAP , ELECT	
C3054	CCEA1HH100T	CAP , ELECT	
C3055	CCEA1HH100T	CAP , ELECT	
C3056	CCEA1HH100T	CAP , ELECT	
C3057	CCEA1HH100T	CAP , ELECT	
C3058	CCEA1HH100T	CAP , ELECT	
C3059	CCEA1CH101T	CAP , ELECT	

LOAD No.	PARTS No.	DESCRIPTION	SPECIATION
C3060	CCEA1CH101T	CAP , ELECT	
C3061	CCEA1CH101T	CAP , ELECT	
C3062	CCEA1CH101T	CAP , ELECT	
C3063	CCEA1CH101T	CAP , ELECT	
C3064	CCEA1CH101T	CAP , ELECT	
C3065	CCEA1CH101T	CAP , ELECT	
C3066	CCEA1CH101T	CAP , ELECT	
C3067	CCEA1HH100T	CAP , ELECT	
C3068	CCEA1HH100T	CAP , ELECT	
C3069	CCEA1HH100T	CAP , ELECT	
C3070	CCEA1HH100T	CAP , ELECT	
C3071	HCQI1H223JZT	CAP , MYLAR	
C3072	HCQI1H473JZT	CAP , MYLAR	
C3073	CCME2A154JXT	CAP , METALLIZED FILM	
C3074	HCQI1H223JZT	CAP , MYLAR	
C3075	HCQI1H473JZT	CAP , MYLAR	
C3076	CCME2A154JXT	CAP , METALLIZED FILM	
C3081	CCEA1HH100T	CAP , ELECT	
C3082	CCEA1HH100T	CAP , ELECT	
C3083	CCEA1HH100T	CAP , ELECT	
C3084	CCEA1HH100T	CAP , ELECT	
C3085	CCEA1HH100T	CAP , ELECT	
C3086	CCEA1HH100T	CAP , ELECT	
C3087	CCEA1HH100T	CAP , ELECT	
C3102	CCEA1HH100T	CAP , ELECT	
C3105	CCEA1HH100T	CAP , ELECT	
C3201	CCEA1HH100T	CAP , ELECT	
C3202	CCEA1HH100T	CAP , ELECT	
C3205	CCEA1HH100T	CAP , ELECT	
C3206	CCEA1HH100T	CAP , ELECT	
C3207	CCEA1CH101T	CAP , ELECT	
C3208	CCEA1CH101T	CAP , ELECT	
C3209	CCEA1HH100T	CAP , ELECT	
C3210	CCEA1HH100T	CAP , ELECT	
C3213	CCEA1HH100T	CAP , ELECT	
C3214	CCEA1HH100T	CAP , ELECT	
C3221	CCEA1CH101T	CAP , ELECT	
C3222	CCEA1CH101T	CAP , ELECT	
C3301	CCEA1HH100T	CAP , ELECT	
C3321	CCEA1CH101T	CAP , ELECT	
C3322	CCEA1CH101T	CAP , ELECT	
C3325	CCEA1CH101T	CAP , ELECT	
C3326	CCEA1CH101T	CAP , ELECT	
C3327	CCEA1CH101T	CAP , ELECT	
C3328	CCEA1CH101T	CAP , ELECT	
C3331	CCEA1CH101T	CAP , ELECT	
C3405	CCEA1CH220T	CAP , ELECT	ONLY AH VERSION
C3424	CCEA1CH101T	CAP , ELECT	ONLY AH VERSION
C3427	CCEA1CH101T	CAP , ELECT	ONLY AH VERSION
C3429	CCEA1CH101T	CAP , ELECT	ONLY AH VERSION
C3430	CCEA1CH101T	CAP , ELECT	ONLY AH VERSION
C3444	CCEA1CH220T	CAP , ELECT	ONLY AH VERSION
C3446	CCEA1HH100T	CAP , ELECT	ONLY AH VERSION
C3451	CCEA1HH100T	CAP , ELECT	ONLY AH VERSION
C3452	CCEA1HH100T	CAP , ELECT	ONLY AH VERSION
C3461	CCEA1HH100T	CAP , ELECT	ONLY AH VERSION
C3462	CCEA1HH100T	CAP , ELECT	ONLY AH VERSION
C3471	CCEA1CH101T	CAP , ELECT	

LOAD No.	PARTS No.	DESCRIPTION	SPECIATION
C3473	CCEA1CH101T	CAP , ELECT	
C3475	CCEA1HH100T	CAP , ELECT	
C3484	CCEA1CH471T	CAP , ELECT	
C3609	CCEA1CH101T	CAP , ELECT	
Q3321	HVTKTC3203YT	T.R	
Q3322	HVTKTA1271YT	T.R	
R3321	CRG1SANJ680RT	RES , METAL OXIDE FILM(1W/68 OHM)	
R3322	CRG1SANJ680RT	RES , METAL OXIDE FILM(1W/68 OHM)	
	CMY2A216SA	M80 REGULATOR HEAT SINK ASS'Y	
	CMY2A216	HEAT SINK	
IC363	CVIKIA7905PI	I.C , REGULATOR(-5V)	
IC364	HVIKIA7809API	I.C , REGULATOR +9V	
IC365	CVIKIA378R00PI	I.C , REGULATOR(3A, TO220IS-4)	
BK301	CMD1A569	BRACKET , PCB	
BN301	CJP15GB99ZY	WAFER	
BN302	CJP15GB99ZY	WAFER	
BN303	CJP15GB99ZY	WAFER	
BN311	CWB1B00910047001	WIRE ASS'Y (SHIELD,9PIN,2mm,100mm,STRAIGH #26)	
CN146	CJP09GI237ZW	LOCKING TYPE , STRAIGHT WAFER , 2.5MM	
CN312	CJP15GA115ZY	WAFER , CARD CABLE	
CN401	CJP13GA115ZY	WAFER , CARD CABLE	
CN561	CJP15GI237ZW	LOCKING TYPE , STRAIGHT WAFER , 2.5MM	
C3432	CCEA1CH102E	CAP , ELECT	ONLY AH VERSION
C3601	CCEA1CH102E	CAP , ELECT	
C3603	CCEA1CH102E	CAP , ELECT	
C3605	CCEA1CH102E	CAP , ELECT	
C3607	CCEA1CH102E	CAP , ELECT	
C3611	CCEA1CH102E	CAP , ELECT	
C3613	CCEA1CH103E	CAP , ELECT	
D3325	CVDZJ7.5BT	DIODE , ZENER 7.5V	
D3326	CVDZJ7.5BT	DIODE , ZENER 7.5V	
IC345	CVIKIA278R05PIHA	I.C HEAT SINK ASS'Y (CMY4A222)	ONLY AH VERSION
	CMY4A222	HEAT SINK	ONLY AH VERSION
IC95	HVIKIA278R05PI	REGULATOR (5V OUTPUT LOW DROP)	ONLY AH VERSION
IC361	CVIKIA278R05PIHA	I.C HEAT SINK ASS'Y (CMY4A222)	
	CMY4A222	HEAT SINK	
IC95	HVIKIA278R05PI	REGULATOR (5V OUTPUT LOW DROP)	
JK301	CJJ4R020W	JACK , BOARD	
JK302	CJJ4P019W	JACK , RCA	
JK303	CJJ4P019W	JACK , RCA	
JK304	CJJ4R020W	JACK , BOARD	
JK305	CJJ4P041Z	JACK IN/OUT	
JK306	CJJ4P042Z	JACK IN/OUT	
JK307	CJJ4P041Z	JACK IN/OUT	
JK308	CJJ4P042Z	JACK IN/OUT	
JK341	CJJ9L006Z	JACK , XM	ONLY AH VERSION
JW301	CWE8102100VV	WIRE , BLACK	ONLY AH VERSION
JW366	CWB3FE03120UP	WIRE ASS'Y (3PIN,3.96mm,120mm,STRAIGHT LUG,#18)	
X3501	HOX04332A200C	CRYSTAL	
PCB6	COP12121D	T747AH AMP PCB ASS'Y	
	CFNCF12610S	FAN (60X60X10)	
	CUP12121X	PCB , AMP T747 (330X247 , FR1/1 LAYER)	
C4841	CCUS1H104KC	CAP , CHIP	
C4842	CCUS1H104KC	CAP , CHIP	
C4843	CCUS1H104KC	CAP , CHIP	
C4844	CCUS1H104KC	CAP , CHIP	
C4845	CCUS1H104KC	CAP , CHIP	
C4850	CCEA1CH101T	CAP , ELECT	ONLY C VERSION

LOAD No.	PARTS No.	DESCRIPTION	SPECIATION
C4851	CCUS1H223KC	CAP , CHIP	ONLY C VERSION
C4852	CCEA1CH101T	CAP , ELECT	ONLY C VERSION
C4853	CCUS1H223KC	CAP , CHIP	ONLY C VERSION
C4871	CCUS1H103KC	CAP , CHIP	
C4872	CCUS1H151JA	CAP , CHIP	ONLY AH VERSION
C4898	CCUS1H151JA	CAP , CHIP	
C4911	CCUS1H470JA	CAP , CHIP	
C4912	CCUS1H470JA	CAP , CHIP	
C4913	CCUS1H470JA	CAP , CHIP	
C4915	CCUS1H104KC	CAP , CHIP	
C4990	CCUS1H104KC	CAP , CHIP	
C4991	CCUS1H104KC	CAP , CHIP	
D4801	CVD1SS355T	DIODE , CHIP	
D4802	CVD1SS355T	DIODE , CHIP	
D4803	CVD1SS355T	DIODE , CHIP	
D4804	CVD1SS355T	DIODE , CHIP	
D4805	CVD1SS355T	DIODE , CHIP	
D4806	CVD1SS355T	DIODE , CHIP	
D4807	CVD1SS355T	DIODE , CHIP	
D4811	CVD1SS355T	DIODE , CHIP	
D4812	CVD1SS355T	DIODE , CHIP	
D4813	CVD1SS355T	DIODE , CHIP	
D4814	CVD1SS355T	DIODE , CHIP	
D4815	CVD1SS355T	DIODE , CHIP	
D4816	CVD1SS355T	DIODE , CHIP	
D4817	CVD1SS355T	DIODE , CHIP	
D4900	CVD1SS355T	DIODE , CHIP	
D4910	CVD1SS355T	DIODE , CHIP	
D4930	CVD1SS355T	DIODE , CHIP	
D4940	CVD1SS355T	DIODE , CHIP	
D4950	CVD1SS355T	DIODE , CHIP	
IC484	HVIST202EBW	IC , RS232C	
Q4871	HVTKRA107S	TR , CHIP	
Q4872	HVTKRA107S	TR , CHIP	
Q4898	HVTKRA107S	TR , CHIP	
Q4901	HVTKRC107S	T.R , CHIP	
Q4902	HVTKRC107S	T.R , CHIP	
Q4904	HVTKRC107S	T.R , CHIP	
Q4905	HVTKRC107S	T.R , CHIP	
Q4906	HVTKRC107S	T.R , CHIP	
R4845	CRJ10DJ100T	RES , CHIP	
R4846	CRJ10DJ1R0T	RES , CHIP	
R4847	CRJ10DJ1R0T	RES , CHIP	
R4851	CRJ10DJ473T	RES , CHIP	ONLY C VERSION
R4871	CRJ10DJ271T	RES , CHIP	
R4872	CRJ10DJ103T	RES , CHIP	
R4873	CRJ10DJ0R0T	RES , CHIP	
R4874	CRJ10DJ0R0T	RES , CHIP	
R4876	CRJ10DJ0R0T	RES , CHIP	
R4878	CRJ10DJ0R0T	RES , CHIP	
R4880	CRJ10DJ0R0T	RES , CHIP	
R4898	CRJ10DJ0R0T	RES , CHIP	
R4911	CRJ10DJ101T	RES , CHIP	
R4912	CRJ10DJ101T	RES , CHIP	
R4913	CRJ10DJ101T	RES , CHIP	
R4914	CRJ10DJ100T	RES , CHIP	
R4915	CRJ10DJ103T	RES , CHIP	
R4992	CRJ10DJ0R0T	RES , CHIP	

LOAD No.	PARTS No.	DESCRIPTION	SPECIATION
R4993	CRJ10DJ0R0T	RES , CHIP	
C4101	CCEA1HH100T	CAP , ELECT	
C4102	CCKT1H221KB	CAP , CERAMIC	
C4103	CCKT1H101KB	CAP , CERAMIC	
C4104	CCEA1CKS470T	CAP , ELECT	
C4105	CCCT1H330JC	CAP , CERAMIC	
C4108	CCKT1H122KB	CAP , CERAMIC	
C4112	CCEA1HH100T	CAP , ELECT	
C4113	CCEA1HH470T	CAP , ELECT	
C4114	CCKT1H101KB	CAP , CERAMIC	
C4116	CCKT1H101KB	CAP , CERAMIC	
C4129	HCQI1H473JZT	CAP , MYLAR	
C4201	CCEA1HH100T	CAP , ELECT	
C4202	CCKT1H221KB	CAP , CERAMIC	
C4203	CCKT1H101KB	CAP , CERAMIC	
C4204	CCEA1CKS470T	CAP , ELECT	
C4205	CCCT1H330JC	CAP , CERAMIC	
C4208	CCKT1H122KB	CAP , CERAMIC	
C4212	CCEA1HH100T	CAP , ELECT	
C4213	CCEA1HH470T	CAP , ELECT	
C4214	CCKT1H101KB	CAP , CERAMIC	
C4216	CCKT1H101KB	CAP , CERAMIC	
C4229	HCQI1H473JZT	CAP , MYLAR	
C4301	CCEA1HH100T	CAP , ELECT	
C4302	CCKT1H221KB	CAP , CERAMIC	
C4303	CCKT1H101KB	CAP , CERAMIC	
C4304	CCEA1CKS470T	CAP , ELECT	
C4305	CCCT1H330JC	CAP , CERAMIC	
C4308	CCKT1H122KB	CAP , CERAMIC	
C4312	CCEA1HH100T	CAP , ELECT	
C4313	CCEA1HH470T	CAP , ELECT	
C4314	CCKT1H101KB	CAP , CERAMIC	
C4316	CCKT1H101KB	CAP , CERAMIC	
C4329	HCQI1H473JZT	CAP , MYLAR	
C4401	CCEA1HH100T	CAP , ELECT	
C4402	CCKT1H221KB	CAP , CERAMIC	
C4403	CCKT1H101KB	CAP , CERAMIC	
C4404	CCEA1CKS470T	CAP , ELECT	
C4405	CCCT1H330JC	CAP , CERAMIC	
C4408	CCKT1H122KB	CAP , CERAMIC	
C4412	CCEA1HH100T	CAP , ELECT	
C4413	CCEA1HH470T	CAP , ELECT	
C4414	CCKT1H101KB	CAP , CERAMIC	
C4416	CCKT1H101KB	CAP , CERAMIC	
C4429	HCQI1H473JZT	CAP , MYLAR	
C4501	CCEA1HH100T	CAP , ELECT	
C4502	CCKT1H221KB	CAP , CERAMIC	
C4503	CCKT1H101KB	CAP , CERAMIC	
C4504	CCEA1CKS470T	CAP , ELECT	
C4505	CCCT1H330JC	CAP , CERAMIC	
C4508	CCKT1H122KB	CAP , CERAMIC	
C4512	CCEA1HH100T	CAP , ELECT	
C4513	CCEA1HH470T	CAP , ELECT	
C4514	CCKT1H101KB	CAP , CERAMIC	
C4516	CCKT1H101KB	CAP , CERAMIC	
C4529	HCQI1H473JZT	CAP , MYLAR	
C4601	CCEA1HH100T	CAP , ELECT	
C4602	CCKT1H221KB	CAP , CERAMIC	

LOAD No.	PARTS No.	DESCRIPTION	SPECIATION
C4603	CCKT1H101KB	CAP , CERAMIC	
C4604	CCEA1CKS470T	CAP , ELECT	
C4605	CCCT1H330JC	CAP , CERAMIC	
C4608	CCKT1H122KB	CAP , CERAMIC	
C4612	CCEA1HH100T	CAP , ELECT	
C4613	CCEA1HH470T	CAP , ELECT	
C4614	CCKT1H101KB	CAP , CERAMIC	
C4616	CCKT1H101KB	CAP , CERAMIC	
C4629	HCQI1H473JZT	CAP , MYLAR	
C4701	CCEA1HH100T	CAP , ELECT	
C4702	CCKT1H221KB	CAP , CERAMIC	
C4704	CCEA1CKS470T	CAP , ELECT	
C4705	CCCT1H330JC	CAP , CERAMIC	
C4708	CCKT1H122KB	CAP , CERAMIC	
C4709	CCKT1H101KB	CAP , CERAMIC	
C4712	CCEA1HH100T	CAP , ELECT	
C4713	CCEA1HH470T	CAP , ELECT	
C4714	CCKT1H101KB	CAP , CERAMIC	
C4716	CCKT1H101KB	CAP , CERAMIC	
C4729	HCQI1H473JZT	CAP , MYLAR	
C4821	CCFT1H103ZF	CAP , CERAMIC	
C4823	CCEA1HKS2R2T	CAP , ELECT	
C4824	CCFT1H103ZF	CAP , CERAMIC	
C4861	CCEA1HH100T	CAP , ELECT	
C4862	CCEA1VH101T	CAP , ELECT	
C4872	CCUS1H151JA	CAP , CHIP	
C4893	CCBS1H103ZFT	CAP , CERAMIC	
C4914	CCEA1AH221T	CAP , ELECT	
C4920	CCFT1H104ZF	CAP , SEMICONDUCTOR	
C4937	CCEA1CH221T	CAP , ELECT	
C4940	CCFT1H104ZF	CAP , SEMICONDUCTOR	
C4944	CCEA1CH101T	CAP , ELECT	
C4947	CCEA1CH221T	CAP , ELECT	
C4950	CCFT1H104ZF	CAP , SEMICONDUCTOR	
C4951	CCEA1HH4R7T	CAP , ELECT	
C4955	CCFT1H104ZF	CAP , SEMICONDUCTOR	
C4957	CCEA0JH102T	CAP , ELECT	
C4961	KCME2E104JP04T	CAP , METALLIZED FILM	
C4962	KCME2E104JP04T	CAP , METALLIZED FILM	
C4963	KCME2E104JP04T	CAP , METALLIZED FILM	
C4964	KCME2E104JP04T	CAP , METALLIZED FILM	
D4115	CVDZJ3.3BT	DIODE , ZENER	
D4116	CVDZJ3.3BT	DIODE , ZENER	
D4117	CVD1SS133MT	DIODE	
D4118	CVD1SS133MT	DIODE	
D4123	CVD1SS133MT	DIODE	
D4215	CVDZJ3.3BT	DIODE , ZENER	
D4216	CVDZJ3.3BT	DIODE , ZENER	
D4217	CVD1SS133MT	DIODE	
D4218	CVD1SS133MT	DIODE	
D4223	CVD1SS133MT	DIODE	
D4315	CVDZJ3.3BT	DIODE , ZENER	
D4316	CVDZJ3.3BT	DIODE , ZENER	
D4317	CVD1SS133MT	DIODE	
D4318	CVD1SS133MT	DIODE	
D4323	CVD1SS133MT	DIODE	
D4415	CVDZJ3.3BT	DIODE , ZENER	
D4416	CVDZJ3.3BT	DIODE , ZENER	

ONLY C VERSION

LOAD No.	PARTS No.	DESCRIPTION	SPECIATION
D4417	CVD1SS133MT	DIODE	
D4418	CVD1SS133MT	DIODE	
D4423	CVD1SS133MT	DIODE	
D4515	CVDZJ3.3BT	DIODE , ZENER	
D4516	CVDZJ3.3BT	DIODE , ZENER	
D4517	CVD1SS133MT	DIODE	
D4518	CVD1SS133MT	DIODE	
D4523	CVD1SS133MT	DIODE	
D4615	CVDZJ3.3BT	DIODE , ZENER	
D4616	CVDZJ3.3BT	DIODE , ZENER	
D4617	CVD1SS133MT	DIODE	
D4618	CVD1SS133MT	DIODE	
D4623	CVD1SS133MT	DIODE	
D4715	CVDZJ3.3BT	DIODE , ZENER	
D4716	CVDZJ3.3BT	DIODE , ZENER	
D4717	CVD1SS133MT	DIODE	
D4718	CVD1SS133MT	DIODE	
D4723	CVD1SS133MT	DIODE	
D4770	CVD1SS133MT	DIODE	
D4821	CVD1SS133MT	DIODE	
D4861	CVD1SS133MT	DIODE	
D4862	CVD1SS133MT	DIODE	
D4863	HVDMTZJ5.1BT	DIODE , ZENER	
D4922	CVD1SS133MT	DIODE	
D4931	CVD1SS133MT	DIODE	
D4942	CVD1SS133MT	DIODE	
D4943	CVDZJ6.8BT	DIODE , ZENER	
D4951	CVD1SS133MT	DIODE	
D4955	C3A206	WIRE , COPPER	
GND49	HJT1A025	PALTE , EARTH	
J4101	C3A206	WIRE , COPPER	
J4102	C3A206	WIRE , COPPER	
J4103	C3A206	WIRE , COPPER	
J4104	C3A206	WIRE , COPPER	
J4105	C3A206	WIRE , COPPER	
J4106	C3A206	WIRE , COPPER	
J4107	C3A206	WIRE , COPPER	
J4108	C3A206	WIRE , COPPER	
J4109	C3A206	WIRE , COPPER	
J4110	C3A206	WIRE , COPPER	
J4111	C3A206	WIRE , COPPER	
J4112	C3A206	WIRE , COPPER	
J4113	CRD20TJ242T	RES , CARBON	
J4114	C3A206	WIRE , COPPER	
J4115	C3A206	WIRE , COPPER	
J4116	C3A206	WIRE , COPPER	
J4117	C3A206	WIRE , COPPER	
J4118	C3A206	WIRE , COPPER	
J4119	C3A206	WIRE , COPPER	
J4120	C3A206	WIRE , COPPER	
J4121	C3A206	WIRE , COPPER	
J4122	C3A206	WIRE , COPPER	
J4123	C3A206	WIRE , COPPER	
J4125	C3A206	WIRE , COPPER	
J4126	C3A206	WIRE , COPPER	
J4127	C3A206	WIRE , COPPER	
J4128	C3A206	WIRE , COPPER	
J4129	C3A206	WIRE , COPPER	

LOAD No.	PARTS No.	DESCRIPTION	SPECIATION
J4130	C3A206	WIRE , COPPER	
J4131	CRD20TJ242T	RES , CARBON	
J4132	C3A206	WIRE , COPPER	
J4133	C3A206	WIRE , COPPER	
J4135	C3A206	WIRE , COPPER	
J4136	C3A206	WIRE , COPPER	
J4137	C3A206	WIRE , COPPER	
J4138	C3A206	WIRE , COPPER	
J4139	C3A206	WIRE , COPPER	
J4140	C3A206	WIRE , COPPER	
J4141	C3A206	WIRE , COPPER	
J4142	C3A206	WIRE , COPPER	
J4144	C3A206	WIRE , COPPER	
J4145	C3A206	WIRE , COPPER	
J4201	C3A206	WIRE , COPPER	
J4202	C3A206	WIRE , COPPER	
J4204	C3A206	WIRE , COPPER	
J4205	C3A206	WIRE , COPPER	
J4206	C3A206	WIRE , COPPER	
J4207	C3A206	WIRE , COPPER	
J4209	C3A206	WIRE , COPPER	
J4211	C3A206	WIRE , COPPER	
J4212	C3A206	WIRE , COPPER	
J4213	C3A206	WIRE , COPPER	
J4215	C3A206	WIRE , COPPER	
J4216	C3A206	WIRE , COPPER	
J4217	C3A206	WIRE , COPPER	
J4218	C3A206	WIRE , COPPER	
J4219	C3A206	WIRE , COPPER	
J4220	C3A206	WIRE , COPPER	
J4221	C3A206	WIRE , COPPER	
J4222	C3A206	WIRE , COPPER	
J4223	C3A206	WIRE , COPPER	
J4224	C3A206	WIRE , COPPER	
J4225	C3A206	WIRE , COPPER	
J4226	C3A206	WIRE , COPPER	
J4227	C3A206	WIRE , COPPER	
J4228	C3A206	WIRE , COPPER	
J4229	C3A206	WIRE , COPPER	
J4230	C3A206	WIRE , COPPER	
J4231	C3A206	WIRE , COPPER	
J4232	C3A206	WIRE , COPPER	
J4233	C3A206	WIRE , COPPER	
J4237	C3A206	WIRE , COPPER	
J4238	C3A206	WIRE , COPPER	
J4239	C3A206	WIRE , COPPER	
J4240	C3A206	WIRE , COPPER	
J4301	C3A206	WIRE , COPPER	
J4302	C3A206	WIRE , COPPER	
J4304	C3A206	WIRE , COPPER	
J4305	C3A206	WIRE , COPPER	
J4306	C3A206	WIRE , COPPER	
J4307	C3A206	WIRE , COPPER	
J4308	C3A206	WIRE , COPPER	
J4309	C3A206	WIRE , COPPER	
J4310	C3A206	WIRE , COPPER	
J4311	C3A206	WIRE , COPPER	
J4312	C3A206	WIRE , COPPER	

LOAD No.	PARTS No.	DESCRIPTION	SPECIATION
J4313	C3A206	WIRE , COPPER	
J4314	C3A206	WIRE , COPPER	
J4315	C3A206	WIRE , COPPER	
J4316	C3A206	WIRE , COPPER	
J4317	C3A206	WIRE , COPPER	
J4318	C3A206	WIRE , COPPER	
J4319	C3A206	WIRE , COPPER	
J4320	C3A206	WIRE , COPPER	
J4322	C3A206	WIRE , COPPER	
J4323	C3A206	WIRE , COPPER	
J4324	C3A206	WIRE , COPPER	
J4325	C3A206	WIRE , COPPER	
J4326	C3A206	WIRE , COPPER	
J4327	C3A206	WIRE , COPPER	
J4328	C3A206	WIRE , COPPER	
J4329	C3A206	WIRE , COPPER	
J4401	C3A206	WIRE , COPPER	
J4402	C3A206	WIRE , COPPER	
J4404	CRD20TJ242T	RES , CARBON	
J4405	C3A206	WIRE , COPPER	
J4406	C3A206	WIRE , COPPER	
J4407	C3A206	WIRE , COPPER	
J4408	C3A206	WIRE , COPPER	
J4409	C3A206	WIRE , COPPER	
J4410	C3A206	WIRE , COPPER	
J4411	C3A206	WIRE , COPPER	
J4412	C3A206	WIRE , COPPER	
J4413	CRD20TJ242T	RES , CARBON	
J4414	CRD20TJ242T	RES , CARBON	
J4415	CRD20TJ242T	RES , CARBON	
J4416	C3A206	WIRE , COPPER	
J4417	C3A206	WIRE , COPPER	
J4418	C3A206	WIRE , COPPER	
J4419	C3A206	WIRE , COPPER	
J4420	C3A206	WIRE , COPPER	
J4421	C3A206	WIRE , COPPER	
J4422	C3A206	WIRE , COPPER	
J4423	C3A206	WIRE , COPPER	
J4424	C3A206	WIRE , COPPER	
J4425	C3A206	WIRE , COPPER	
J4426	C3A206	WIRE , COPPER	
J4427	C3A206	WIRE , COPPER	
J4428	C3A206	WIRE , COPPER	
J4429	C3A206	WIRE , COPPER	
J4430	C3A206	WIRE , COPPER	
J4431	C3A206	WIRE , COPPER	
J4432	C3A206	WIRE , COPPER	
J4433	CRD20TJ242T	RES , CARBON	
J4434	C3A206	WIRE , COPPER	
J4435	C3A206	WIRE , COPPER	
J4436	C3A206	WIRE , COPPER	
J4437	C3A206	WIRE , COPPER	
J4438	C3A206	WIRE , COPPER	
J4439	C3A206	WIRE , COPPER	
J4440	C3A206	WIRE , COPPER	
J4441	C3A206	WIRE , COPPER	
J4442	C3A206	WIRE , COPPER	
J4443	C3A206	WIRE , COPPER	

LOAD No.	PARTS No.	DESCRIPTION	SPECIATION
J4444	C3A206	WIRE , COPPER	ONLY C VERSION
J4445	CRD20TJ100T	RES , CARBON	
J4446	C3A206	WIRE , COPPER	
J4447	C3A206	WIRE , COPPER	
J4501	C3A206	WIRE , COPPER	
J4502	C3A206	WIRE , COPPER	
J4503	C3A206	WIRE , COPPER	
J4504	C3A206	WIRE , COPPER	
J4505	C3A206	WIRE , COPPER	
J4507	C3A206	WIRE , COPPER	
J4508	C3A206	WIRE , COPPER	
J4509	C3A206	WIRE , COPPER	
J4510	C3A206	WIRE , COPPER	
J4511	C3A206	WIRE , COPPER	
J4512	C3A206	WIRE , COPPER	
J4514	C3A206	WIRE , COPPER	
J4601	C3A206	WIRE , COPPER	
J4602	C3A206	WIRE , COPPER	
J4603	C3A206	WIRE , COPPER	
J4604	C3A206	WIRE , COPPER	
J4605	C3A206	WIRE , COPPER	
J4606	C3A206	WIRE , COPPER	
J4607	C3A206	WIRE , COPPER	
J4608	C3A206	WIRE , COPPER	
J4609	C3A206	WIRE , COPPER	
J4610	C3A206	WIRE , COPPER	
J4611	C3A206	WIRE , COPPER	
J4612	C3A206	WIRE , COPPER	
J4613	C3A206	WIRE , COPPER	
J4614	C3A206	WIRE , COPPER	
J4615	C3A206	WIRE , COPPER	
J4617	C3A206	WIRE , COPPER	
J4619	C3A206	WIRE , COPPER	
J4620	C3A206	WIRE , COPPER	
J4621	C3A206	WIRE , COPPER	
J4622	C3A206	WIRE , COPPER	
J4624	C3A206	WIRE , COPPER	
J4627	C3A206	WIRE , COPPER	
J4628	C3A206	WIRE , COPPER	
J4631	C3A206	WIRE , COPPER	
J4632	C3A206	WIRE , COPPER	
J4633	C3A206	WIRE , COPPER	
J4634	C3A206	WIRE , COPPER	
J4635	C3A206	WIRE , COPPER	
J4636	C3A206	WIRE , COPPER	
J4637	C3A206	WIRE , COPPER	
J4640	C3A206	WIRE , COPPER	
J4641	C3A206	WIRE , COPPER	
J4642	C3A206	WIRE , COPPER	
J4643	C3A206	WIRE , COPPER	
J4644	C3A206	WIRE , COPPER	
J4645	C3A206	WIRE , COPPER	
J4646	C3A206	WIRE , COPPER	
J4701	C3A206	WIRE , COPPER	ONLY C VERSION
J4702	C3A206	WIRE , COPPER	
J4703	C3A206	WIRE , COPPER	
J4704	C3A206	WIRE , COPPER	
J4705	C3A206	WIRE , COPPER	

LOAD No.	PARTS No.	DESCRIPTION	SPECIATION
J4802	C3A206	WIRE , COPPER	
J4803	C3A206	WIRE , COPPER	
J4804	C3A206	WIRE , COPPER	
J4805	C3A206	WIRE , COPPER	
J4806	C3A206	WIRE , COPPER	
J4807	C3A206	WIRE , COPPER	
J4808	C3A206	WIRE , COPPER	
J4901	C3A206	WIRE , COPPER	
J4902	C3A206	WIRE , COPPER	
J4903	C3A206	WIRE , COPPER	
J4904	C3A206	WIRE , COPPER	
J4905	C3A206	WIRE , COPPER	
J4906	C3A206	WIRE , COPPER	
J4907	C3A206	WIRE , COPPER	
J4908	C3A206	WIRE , COPPER	
J4909	C3A206	WIRE , COPPER	
J4910	C3A206	WIRE , COPPER	
J4911	C3A206	WIRE , COPPER	
J4912	C3A206	WIRE , COPPER	
J4913	C3A206	WIRE , COPPER	
J4914	C3A206	WIRE , COPPER	
J4915	C3A206	WIRE , COPPER	
J4916	C3A206	WIRE , COPPER	
J4917	C3A206	WIRE , COPPER	
J4918	C3A206	WIRE , COPPER	
J4919	C3A206	WIRE , COPPER	
J4920	C3A206	WIRE , COPPER	
J4921	C3A206	WIRE , COPPER	
J4922	C3A206	WIRE , COPPER	
J4923	C3A206	WIRE , COPPER	
J4924	C3A206	WIRE , COPPER	
J4925	C3A206	WIRE , COPPER	
J4926	C3A206	WIRE , COPPER	
J4927	C3A206	WIRE , COPPER	
J4928	C3A206	WIRE , COPPER	
J4929	C3A206	WIRE , COPPER	
J4930	C3A206	WIRE , COPPER	
J4931	C3A206	WIRE , COPPER	
J4931	C3A206	WIRE , COPPER	
Q4101	CVTKTA1268GRATPA	T.R	
Q4102	CVTKTA1268GRATPA	T.R	
Q4110	HVTKTC3200GRT	T.R	
Q4124	HVTKSC2785YT	T.R	
Q4124	HVTKTC3199YT	T.R	
Q4201	CVTKTA1268GRATPA	T.R	
Q4202	CVTKTA1268GRATPA	T.R	
Q4210	HVTKTC3200GRT	T.R	
Q4224	HVTKSC2785YT	T.R	
Q4224	HVTKTC3199YT	T.R	
Q4301	CVTKTA1268GRATPA	T.R	
Q4302	CVTKTA1268GRATPA	T.R	
Q4310	HVTKTC3200GRT	T.R	
Q4324	HVTKSC2785YT	T.R	
Q4324	HVTKTC3199YT	T.R	
Q4401	CVTKTA1268GRATPA	T.R	
Q4402	CVTKTA1268GRATPA	T.R	
Q4410	HVTKTC3200GRT	T.R	
Q4424	HVTKSC2785YT	T.R	

ONLY C VERSION

LOAD No.	PARTS No.	DESCRIPTION	SPECIATION
Q4424	HVTKTC3199YT	T.R	
Q4501	CVTKTA1268GRATPA	T.R	
Q4502	CVTKTA1268GRATPA	T.R	
Q4510	HVTKTC3200GRT	T.R	
Q4524	HVTKSC2785YT	T.R	
Q4524	HVTKTC3199YT	T.R	
Q4601	CVTKTA1268GRATPA	T.R	
Q4602	CVTKTA1268GRATPA	T.R	
Q4610	HVTKTC3200GRT	T.R	
Q4624	HVTKSC2785YT	T.R	
Q4624	HVTKTC3199YT	T.R	
Q4701	CVTKTA1268GRATPA	T.R	
Q4702	CVTKTA1268GRATPA	T.R	
Q4710	HVTKTC3200GRT	T.R	
Q4724	HVTKSC2785YT	T.R	
Q4724	HVTKTC3199YT	T.R	
Q4769	HVTKSC2785YT	T.R	
Q4769	HVTKTC3199YT	T.R	
Q4821	HVTKTC3200GRT	T.R	
Q4822	HVTKTA1268GRT	T.R	
Q4825	HVTKTA1268GRT	T.R	
Q4826	HVTKTA1268GRT	T.R	
Q4861	HVTKRC111MT	T.R	
Q4862	HVTKRC107MT	T.R	
Q4892	HVTKRC107MT	T.R	
Q4893	CVTKTA1272YT	T.R , KTA1272Y-AP/P(TO-92M)	
Q4925	HVTKSC2785YT	T.R	
Q4925	HVTKTC3199YT	T.R	
Q4931	HVTKRC107MT	T.R	
Q4934	CVTKTA1272YT	T.R , KTA1272Y-AP/P(TO-92M)	
Q4942	HVTKRC107MT	T.R	
Q4944	CVTKTA1272YT	T.R , KTA1272Y-AP/P(TO-92M)	
Q4950	HVTKSA1175YT	T.R	
Q4950	HVTKTA1267YT	T.R	
Q4954	HVTKSC2785YT	T.R	
Q4954	HVTKTC3199YT	T.R	
Q4955	HVTKSA1175YT	T.R	
Q4955	HVTKTA1267YT	T.R	
Q4956	HVTKSC2785YT	T.R	
Q4956	HVTKTC3199YT	T.R	
Q4957	HVTKSC2785YT	T.R	
Q4957	HVTKTC3199YT	T.R	
R4101	CRD20TJ221T	RES , CARBON	
R4102	CRD20TJ912T	RES , CARBON	
R4103	CRD20TJ333T	RES , CARBON	
R4104	CRD20TJ152T	RES , CARBON	
R4105	CRD20TJ333T	RES , CARBON	
R4106	CRD20TJ474T	RES , CARBON	
R4107	CRD20TJ473T	RES , CARBON	
R4108	CRD20TJ471T	RES , CARBON	
R4109	CRD20TJ112T	RES , CARBON	
R4110	CRD25FJ100T	RES , CARBON	
R4111	CRD20TJ102T	RES , CARBON	
R4112	CRD20TJ332T	RES , CARBON	
R4113	CRG1SANJ562RT	RES , METAL OXIDE FILM	
R4114	CRG1SANJ562RT	RES , METAL OXIDE FILM	
R4115	CRD25FJ4R7T	RES , CARBON	
R4116	CRD25FJ4R7T	RES , CARBON	

LOAD No.	PARTS No.	DESCRIPTION	SPECIATION
R4117	KRG1SANJ100RT	RES , METAL OXIDE FILM	
R4122	CRD20TJ103T	RES , CARBON	
R4123	CRD20TJ334T	RES , CARBON	
R4124	CRD20TJ223T	RES , CARBON	
R4125	CRD20TJ223T	RES , CARBON	
R4126	CRD25TJ220T	RES , CARBON	
R4127	CRD25TJ220T	RES , CARBON	
R4128	KRG1SANJ100RT	RES , METAL OXIDE FILM	
R4201	CRD20TJ221T	RES , CARBON	
R4202	CRD20TJ912T	RES , CARBON	
R4203	CRD20TJ333T	RES , CARBON	
R4204	CRD20TJ152T	RES , CARBON	
R4205	CRD20TJ333T	RES , CARBON	
R4206	CRD20TJ474T	RES , CARBON	
R4207	CRD20TJ473T	RES , CARBON	
R4208	CRD20TJ471T	RES , CARBON	
R4209	CRD20TJ112T	RES , CARBON	
R4210	CRD25FJ100T	RES , CARBON	
R4211	CRD20TJ102T	RES , CARBON	
R4212	CRD20TJ332T	RES , CARBON	
R4213	CRG1SANJ562RT	RES , METAL OXIDE FILM	
R4214	CRG1SANJ562RT	RES , METAL OXIDE FILM	
R4215	CRD25FJ4R7T	RES , CARBON	
R4216	CRD25FJ4R7T	RES , CARBON	
R4217	KRG1SANJ100RT	RES , METAL OXIDE FILM	
R4222	CRD20TJ103T	RES , CARBON	
R4223	CRD20TJ334T	RES , CARBON	
R4224	CRD20TJ223T	RES , CARBON	
R4225	CRD20TJ223T	RES , CARBON	
R4226	CRD25TJ220T	RES , CARBON	
R4227	CRD25TJ220T	RES , CARBON	
R4228	KRG1SANJ100RT	RES , METAL OXIDE FILM	
R4301	CRD20TJ221T	RES , CARBON	
R4302	CRD20TJ912T	RES , CARBON	
R4303	CRD20TJ333T	RES , CARBON	
R4304	CRD20TJ152T	RES , CARBON	
R4305	CRD20TJ333T	RES , CARBON	
R4306	CRD20TJ474T	RES , CARBON	
R4307	CRD20TJ473T	RES , CARBON	
R4308	CRD20TJ471T	RES , CARBON	
R4309	CRD20TJ112T	RES , CARBON	
R4310	CRD25FJ100T	RES , CARBON	
R4311	CRD20TJ102T	RES , CARBON	
R4312	CRD20TJ332T	RES , CARBON	
R4313	CRG1SANJ562RT	RES , METAL OXIDE FILM	
R4314	CRG1SANJ562RT	RES , METAL OXIDE FILM	
R4315	CRD25FJ4R7T	RES , CARBON	
R4316	CRD25FJ4R7T	RES , CARBON	
R4317	KRG1SANJ100RT	RES , METAL OXIDE FILM	
R4322	CRD20TJ103T	RES , CARBON	
R4323	CRD20TJ334T	RES , CARBON	
R4324	CRD20TJ223T	RES , CARBON	
R4325	CRD20TJ223T	RES , CARBON	
R4326	CRD25TJ220T	RES , CARBON	
R4327	CRD25TJ220T	RES , CARBON	
R4328	KRG1SANJ100RT	RES , METAL OXIDE FILM	
R4401	CRD20TJ221T	RES , CARBON	
R4402	CRD20TJ912T	RES , CARBON	

LOAD No.	PARTS No.	DESCRIPTION	SPECIATION
R4403	CRD20TJ333T	RES , CARBON	
R4404	CRD20TJ152T	RES , CARBON	
R4405	CRD20TJ333T	RES , CARBON	
R4406	CRD20TJ474T	RES , CARBON	
R4407	CRD20TJ473T	RES , CARBON	
R4408	CRD20TJ471T	RES , CARBON	
R4409	CRD20TJ112T	RES , CARBON	
R4410	CRD25FJ100T	RES , CARBON	
R4411	CRD20TJ102T	RES , CARBON	
R4412	CRD20TJ332T	RES , CARBON	
R4413	CRG1SANJ562RT	RES , METAL OXIDE FILM	
R4414	CRG1SANJ562RT	RES , METAL OXIDE FILM	
R4415	CRD25FJ4R7T	RES , CARBON	
R4416	CRD25FJ4R7T	RES , CARBON	
R4417	KRG1SANJ100RT	RES , METAL OXIDE FILM	
R4422	CRD20TJ103T	RES , CARBON	
R4423	CRD20TJ334T	RES , CARBON	
R4424	CRD20TJ223T	RES , CARBON	
R4425	CRD20TJ223T	RES , CARBON	
R4426	CRD25TJ220T	RES , CARBON	
R4427	CRD25TJ220T	RES , CARBON	
R4428	KRG1SANJ100RT	RES , METAL OXIDE FILM	
R4501	CRD20TJ221T	RES , CARBON	
R4502	CRD20TJ912T	RES , CARBON	
R4503	CRD20TJ333T	RES , CARBON	
R4504	CRD20TJ152T	RES , CARBON	
R4505	CRD20TJ333T	RES , CARBON	
R4506	CRD20TJ474T	RES , CARBON	
R4507	CRD20TJ473T	RES , CARBON	
R4508	CRD20TJ471T	RES , CARBON	
R4509	CRD20TJ112T	RES , CARBON	
R4510	CRD25FJ100T	RES , CARBON	
R4511	CRD20TJ102T	RES , CARBON	
R4512	CRD20TJ332T	RES , CARBON	
R4513	CRG1SANJ562RT	RES , METAL OXIDE FILM	
R4514	CRG1SANJ562RT	RES , METAL OXIDE FILM	
R4515	CRD25FJ4R7T	RES , CARBON	
R4516	CRD25FJ4R7T	RES , CARBON	
R4517	KRG1SANJ100RT	RES , METAL OXIDE FILM	
R4522	CRD20TJ103T	RES , CARBON	
R4523	CRD20TJ334T	RES , CARBON	
R4524	CRD20TJ223T	RES , CARBON	
R4525	CRD20TJ223T	RES , CARBON	
R4526	CRD25TJ220T	RES , CARBON	
R4527	CRD25TJ220T	RES , CARBON	
R4528	KRG1SANJ100RT	RES , METAL OXIDE FILM	
R4601	CRD20TJ221T	RES , CARBON	
R4602	CRD20TJ912T	RES , CARBON	
R4603	CRD20TJ333T	RES , CARBON	
R4604	CRD20TJ152T	RES , CARBON	
R4605	CRD20TJ333T	RES , CARBON	
R4606	CRD20TJ474T	RES , CARBON	
R4607	CRD20TJ473T	RES , CARBON	
R4608	CRD20TJ471T	RES , CARBON	
R4609	CRD20TJ112T	RES , CARBON	
R4610	CRD25FJ100T	RES , CARBON	
R4611	CRD20TJ102T	RES , CARBON	
R4612	CRD20TJ332T	RES , CARBON	

LOAD No.	PARTS No.	DESCRIPTION	SPECIATION
R4613	CRG1SANJ562RT	RES , METAL OXIDE FILM	
R4614	CRG1SANJ562RT	RES , METAL OXIDE FILM	
R4615	CRD25FJ4R7T	RES , CARBON	
R4616	CRD25FJ4R7T	RES , CARBON	
R4617	KRG1SANJ100RT	RES , METAL OXIDE FILM	
R4622	CRD20TJ103T	RES , CARBON	
R4623	CRD20TJ334T	RES , CARBON	
R4624	CRD20TJ223T	RES , CARBON	
R4625	CRD20TJ223T	RES , CARBON	
R4626	CRD25TJ220T	RES , CARBON	
R4627	CRD25TJ220T	RES , CARBON	
R4628	KRG1SANJ100RT	RES , METAL OXIDE FILM	
R4666	CRD20TJ473T	RES , CARBON	
R4701	CRD20TJ221T	RES , CARBON	
R4702	CRD20TJ912T	RES , CARBON	
R4703	CRD20TJ333T	RES , CARBON	
R4704	CRD20TJ152T	RES , CARBON	
R4705	CRD20TJ333T	RES , CARBON	
R4706	CRD20TJ474T	RES , CARBON	
R4707	CRD20TJ473T	RES , CARBON	
R4708	CRD20TJ471T	RES , CARBON	
R4709	CRD20TJ112T	RES , CARBON	
R4710	CRD25FJ100T	RES , CARBON	
R4711	CRD20TJ102T	RES , CARBON	
R4712	CRD20TJ332T	RES , CARBON	
R4713	CRG1SANJ562RT	RES , METAL OXIDE FILM	
R4714	CRG1SANJ562RT	RES , METAL OXIDE FILM	
R4715	CRD25FJ4R7T	RES , CARBON	
R4716	CRD25FJ4R7T	RES , CARBON	
R4717	KRG1SANJ100RT	RES , METAL OXIDE FILM	
R4722	CRD20TJ103T	RES , CARBON	
R4723	CRD20TJ334T	RES , CARBON	
R4724	CRD20TJ223T	RES , CARBON	
R4725	CRD20TJ223T	RES , CARBON	
R4726	CRD25TJ220T	RES , CARBON	
R4727	CRD25TJ220T	RES , CARBON	
R4728	KRG1SANJ100RT	RES , METAL OXIDE FILM	
R4765	CRD20TJ103T	RES , CARBON	
R4767	CRD20TJ223T	RES , CARBON	
R4768	CRD20TJ223T	RES , CARBON	
R4769	CRD20TJ152T	RES , CARBON	
R4820	CRD20TJ222T	RES , CARBON	
R4821	CRD20TJ222T	RES , CARBON	
R4822	CRD20TJ222T	RES , CARBON	
R4823	CRD20TJ564T	RES , CARBON	
R4824	CRD20TJ362T	RES , CARBON	
R4825	CRD20TJ223T	RES , CARBON	
R4826	CRD20TJ222T	RES , CARBON	
R4827	CRD20TJ564T	RES , CARBON	
R4831	CRD20TJ272T	RES , CARBON	
R4832	CRD20TJ151T	RES , CARBON	
R4861	CRD20TJ102T	RES , CARBON	
R4862	CRD20TJ334T	RES , CARBON	
R4863	CRD20TJ473T	RES , CARBON	
R4890	CRD20TJ752T	RES , CARBON	
R4891	CRD20TJ752T	RES , CARBON	
R4893	CRD20TJ103T	RES , CARBON	
R4895	CRD20TJ103T	RES , CARBON	

LOAD No.	PARTS No.	DESCRIPTION	SPECIATION
R4901	KRG1SANJ391RT	RES , METAL OXIDE FILM	
R4902	KRG1SANJ391RT	RES , METAL OXIDE FILM	
R4921	C3A206	WIRE , COPPER	
R4922	CRD20TJ102T	RES , CARBON	
R4923	CRD20TJ102T	RES , CARBON	
R4924	CRD20TJ203T	RES , CARBON	
R4925	CRD20TJ132T	RES , CARBON	
R4931	CRD20TJ333T	RES , CARBON	
R4932	CRD20TJ123T	RES , CARBON	
R4933	CRD20TJ562T	RES , CARBON	
R4934	KRG1SANJ4R7RT	RES, METAL(OXIDE)FILM,5%	
R4935	CRD20TJ103T	RES , CARBON	
R4936	KRG1SANJ100RT	RES , METAL OXIDE FILM	
R4937	CRD20TJ104T	RES , CARBON	
R4938	KRG1SANJ100RT	RES , METAL OXIDE FILM	
R4944	CRD25TJ100T	RES , CARBON	
R4945	CRD20TJ103T	RES , CARBON	
R4946	KRG1SANJ470RT	RES , METAL OXIDE FILM	
R4947	CRD20TJ104T	RES , CARBON	
R4951	CRD20TJ153T	RES , CARBON	
R4952	CRD20TJ473T	RES , CARBON	
R4953	CRD20TJ102T	RES , CARBON	
R4957	CRD20TJ332T	RES , CARBON	
R4958	CRD20TJ222T	RES , CARBON	
R4959	CRD20TJ153T	RES , CARBON	
R4961	CRD20TJ153T	RES , CARBON	
R4962	CRD20TJ153T	RES , CARBON	
R4963	CRD20TJ153T	RES , CARBON	
R4964	CRD20TJ153T	RES , CARBON	
R4965	CRD20TJ153T	RES , CARBON	
R4966	CRD20TJ153T	RES , CARBON	
R4968	CRD25TJ223T	RES , CARBON	
R4969	CRD25TJ223T	RES , CARBON	
R4970	CRD25TJ223T	RES , CARBON	
R4971	CRD25TJ223T	RES , CARBON	
R4976	CRD20TJ153T	RES , CARBON	
R4977	CRD20TJ153T	RES , CARBON	
R4978	CRD20TJ153T	RES , CARBON	
VR410	CVN1RA221B02T	RES , SEMI FIXED (220, B CURVE)	
VR420	CVN1RA221B02T	RES , SEMI FIXED (220, B CURVE)	
VR430	CVN1RA221B02T	RES , SEMI FIXED (220, B CURVE)	
VR440	CVN1RA221B02T	RES , SEMI FIXED (220, B CURVE)	
VR450	CVN1RA221B02T	RES , SEMI FIXED (220, B CURVE)	
VR460	CVN1RA221B02T	RES , SEMI FIXED (220, B CURVE)	
VR470	CVN1RA221B02T	RES , SEMI FIXED (220, B CURVE)	
	CMD1A688	BRACKET , HEAT SINK	
	CMYM80	M80 MAIN HEAT SINK ASS'Y (CMY1A310)	
	CFNKDE1208PTV1	MOTOR , DC BRUSHLESS FAN(80X80X25mm)	
	CMD1A694	BRACKET , FAN	
	CMY1A310	HEAT SINK	
Q4115	CVT2SD2560P43M	TR , POWER (MICA 43 TYPE)	
Q4116	CVT2SB1647P43M	TR , POWER (MICA 43 TYPE)	
Q4215	CVT2SD2560P43M	TR , POWER (MICA 43 TYPE)	
Q4216	CVT2SB1647P43M	TR , POWER (MICA 43 TYPE)	
Q4315	CVT2SD2560P43M	TR , POWER (MICA 43 TYPE)	
Q4316	CVT2SB1647P43M	TR , POWER (MICA 43 TYPE)	
Q4415	CVT2SD2560P43M	TR , POWER (MICA 43 TYPE)	
Q4416	CVT2SB1647P43M	TR , POWER (MICA 43 TYPE)	

LOAD No.	PARTS No.	DESCRIPTION	SPECIATION
Q4515	CVT2SD2560P43M	TR , POWER (MICA 43 TYPE)	
Q4516	CVT2SB1647P43M	TR , POWER (MICA 43 TYPE)	
Q4615	CVT2SD2560P43M	TR , POWER (MICA 43 TYPE)	
Q4616	CVT2SB1647P43M	TR , POWER (MICA 43 TYPE)	
Q4715	CVT2SD2560P43M	TR , POWER (MICA 43 TYPE)	
Q4716	CVT2SB1647P43M	TR , POWER (MICA 43 TYPE)	
TH492	CRSYPSX08850JD	POSISTOR , ASS'Y	
BK402	CMD1A629	BRACKET , PCB	
BN410	CWZM80BN410	WIRE ASS'Y (2PIN,3.96mm,STRAIGHT LUG,#18)	
BN411	CWZM80BN411	WIRE ASS'Y (2PIN,3.96mm,STRAIGHT LUG,#18)	
BN412	CWZM80BN412	WIRE ASS'Y (3PIN,3.96mm,STRAIGHT LUG,#18)	
BN490	CWB1B00540047001	WIRE ASS'Y (SHIELD,5PIN,2mm,400mm,STRAIGHT,#26)	
BN492	CWB1B00530058	WIRE ASS'Y (5PIN,2.5mm,300mm,STRAIGHT,#26)	
BN494	CWB1B00540047	WIRE ASS'Y (9PIN,2mm,400mm,STRAIGHT,#26)	
CN401	CJP13GA115ZY	WAFER , CARD CABLE	
CN410	CJP02GA01ZY	WAFER , STRAIGHT, 2PIN	
CN420	CJP02GA01ZY	WAFER , STRAIGHT, 2PIN	
CN430	CJP02GA01ZY	WAFER , STRAIGHT, 2PIN	
CN440	CJP02GA01ZY	WAFER , STRAIGHT, 2PIN	
CN450	CJP02GA01ZY	WAFER , STRAIGHT, 2PIN	
CN460	CJP02GA01ZY	WAFER , STRAIGHT, 2PIN	
CN466	CJP03GA90ZY	WAFER	
CN470	CJP02GA01ZY	WAFER , STRAIGHT, 2PIN	
CN490	CJP15GA98ZM	WAFER	
CN490	CJP15GA98ZY	WAFER	
CN491	CJP05GA98ZY	WAFER	
CN491	CJP07GA98ZM	WAFER , STRAIGHT (2MM,7PIN)	
CN496	CJP03GA89ZY	WAFER	
CN497	CJP02GA01ZY	WAFER , STRAIGHT, 2PIN	
CN498	CJP02GA01ZY	WAFER , STRAIGHT, 2PIN	
CN499	CJP02GA01ZY	WAFER , STRAIGHT, 2PIN	
C4117	CCEA2AH101E	CAP , ELECT	
C4217	CCEA2AH101E	CAP , ELECT	
C4317	CCEA2AH101E	CAP , ELECT	
C4417	CCEA2AH101E	CAP , ELECT	
C4517	CCEA2AH101E	CAP , ELECT	
C4617	CCEA2AH101E	CAP , ELECT	
C4717	CCEA2AH101E	CAP , ELECT	
C4972	CCET63VKL5183NK	CAP , ELECT	
C4973	CCET63VKL5183NK	CAP , ELECT	
D4965	CVDGBJ1506BGA	M80 DIODE HEAT SINK ASS'Y (CMY4A138)	
	CMY4A138	HEAT SINK , DIODE	
	HVDGBJ1506	DIODE, BRIDGE.(600V)	
IC466	CVIKIA578R05PI	I.C , REGULATOR 5A	
IC485	CVIKIA78R05PIGA		ONLY C VERSION
	HVIKIA78R05PI		ONLY C VERSION
IC487	BVIKP1010B	IC, PHOTO COUPLER	
IC491	HVICD4094BE	I.C , SHIFT REGISTER	
JK484	CJJ9W001Z	JACK , 9P D-SUB FEMALE(RS-232C, SEMCO)	
JK485	CJS6V001Z	JACK , DIN 9P(DIN-901A1)	ONLY C VERSION
JK486	CJJ2D012Z	JACK , (3.5mm/GREEN/iPOD DATA PORT)	
JK487	HJJ1D002Z	JACK , STEREO(2P 3.5PIE)	
JK489	HJJ1D002Z	JACK , STEREO(2P 3.5PIE)	
JK492	CJJ5N005Z	TERMINAL , SP (R/B)	
JK494	CJJ5P011Z	TERMINAL , SPEAKER	
JK495	CJJ5Q007Z	TERMINAL,SP(RRRR/BBBB)	
JW410	CWE8102100VV	WIRE , BLACK	
JW411	CWE8112120VV	WIRE ASS'Y (1PIN,120mm,LUG,#18,RED)	

LOAD No.	PARTS No.	DESCRIPTION	SPECIATION
JW412	CWE8101120VV	WIRE ASS'Y (1PIN,120mm,LUG,#18,BLUE)	
L4126	CLEY0R5KAK	COIL , SPEAKER	
L4226	CLEY0R5KAK	COIL , SPEAKER	
L4326	CLEY0R5KAK	COIL , SPEAKER	
L4426	CLEY0R5KAK	COIL , SPEAKER	
L4526	CLEY0R5KAK	COIL , SPEAKER	
L4626	CLEY0R5KAK	COIL , SPEAKER	
L4726	CLEY0R5KAK	COIL , SPEAKER	
Q4112	CVTKTD1028BATP	T.R	
Q4212	CVTKTD1028BATP	T.R	
Q4312	CVTKTD1028BATP	T.R	
Q4412	CVTKTD1028BATP	T.R	
Q4512	CVTKTD1028BATP	T.R	
Q4612	CVTKTD1028BATP	T.R	
Q4712	CVTKTD1028BATP	T.R	
RY491	CSL3A018ZE	RELAY	
RY492	CSL3A018ZE	RELAY	
RY494	CSL3A018ZE	RELAY	
RY495	CSL3A018ZE	RELAY	
RY496	CSL3A018ZE	RELAY	
R4118	CRF5EKR22X2	RES , CEMENT	
R4218	CRF5EKR22X2	RES , CEMENT	
R4318	CRF5EKR22X2	RES , CEMENT	
R4418	CRF5EKR22X2	RES , CEMENT	
R4518	CRF5EKR22X2	RES , CEMENT	
R4618	CRF5EKR22X2	RES , CEMENT	
R4718	CRF5EKR22X2	RES , CEMENT	
R4828	CRF5EKR10H	RES , CEMENT	
R4829	CRF5EKR10H	RES , CEMENT	
R4894	CRG2SANJ820RT	RES , METAL OXIDE FILM	
SW480	CST1A010Z	SW , TACT	
TH492	CJP02GA01ZY	WAFER , STRAIGHT, 2PIN	
	CUP12120Z	PCB , HDMI M80 (194X181 , FR4/6)	
C1401	CCUS1H104KC	CAP , CHIP	
C1402	CCUS1H104KC	CAP , CHIP	
C1403	CCUS1H104KC	CAP , CHIP	
C1404	CCUS1H104KC	CAP , CHIP	
C1405	CCUS1H104KC	CAP , CHIP	
C1406	CCUS1H104KC	CAP , CHIP	
C1407	CCUS1H104KC	CAP , CHIP	
C1408	CCSJA1C100B	CAP , CHIP TANTAL(A TYPE, 10uF/16V, ELNA)	
C1409	CCUS1H104KC	CAP , CHIP	
C1410	CCUS1H104KC	CAP , CHIP	
C1411	CCUS1H104KC	CAP , CHIP	
C1412	CCUS1H104KC	CAP , CHIP	
C1413	CCUS1H104KC	CAP , CHIP	
C1414	CCUS1H104KC	CAP , CHIP	
C1415	CCUS1H104KC	CAP , CHIP	
C1416	CCUS1H104KC	CAP , CHIP	
C1417	CCUS1H104KC	CAP , CHIP	
C1418	CCUS1H104KC	CAP , CHIP	
C1419	CCUS1H104KC	CAP , CHIP	
C1420	CCSJA0J220B	CAP , CHIP TANTAL(A TYPE, 22uF/6.3V, ELNA)	
C1421	CCUS1H104KC	CAP , CHIP	
C1422	CCSJA0J220B	CAP , CHIP TANTAL(A TYPE, 22uF/6.3V, ELNA)	
C1423	CCUS1H104KC	CAP , CHIP	
C1424	CCUS1H104KC	CAP , CHIP	
C1425	CCUS1H104KC	CAP , CHIP	

LOAD No.	PARTS No.	DESCRIPTION	SPECIATION
C1426	CCUS1H104KC	CAP , CHIP	
C1427	CCUS1H104KC	CAP , CHIP	
C1428	CCUS1H104KC	CAP , CHIP	
C1429	CCUS1H104KC	CAP , CHIP	
C1430	CCUS1H104KC	CAP , CHIP	
C1431	CCUS1H104KC	CAP , CHIP	
C1432	CCUS1H104KC	CAP , CHIP	
C1433	CCUS1H104KC	CAP , CHIP	
C1434	CCUS1H104KC	CAP , CHIP	
C1437	CCSJA0J220B	CAP , CHIP TANTAL(A TYPE, 22uF/6.3V, ELNA)	
C1438	CCUS1H104KC	CAP , CHIP	
C1439	CCSJA1C100B	CAP , CHIP TANTAL(A TYPE, 10uF/16V, ELNA)	
C1440	CCUS1H104KC	CAP , CHIP	
C1441	CCUS1H104KC	CAP , CHIP	
C1442	CCUS1H104KC	CAP , CHIP	
C1443	CCUS1H104KC	CAP , CHIP	
C1444	CCUS1H104KC	CAP , CHIP	
C1445	CCUS1H104KC	CAP , CHIP	
C1446	CCUS1H104KC	CAP , CHIP	
C1447	CCUS1H104KC	CAP , CHIP	
C1448	CCUS1H104KC	CAP , CHIP	
C1449	CCUS1H104KC	CAP , CHIP	
C1450	CCUS1H104KC	CAP , CHIP	
C1451	CCUS1H104KC	CAP , CHIP	
C1452	CCSJA0J220B	CAP , CHIP TANTAL(A TYPE, 22uF/6.3V, ELNA)	
C1454	CCUS1H104KC	CAP , CHIP	
C1455	CCUS1H104KC	CAP , CHIP	
C1456	CCUS1H104KC	CAP , CHIP	
C1457	CCUS1H104KC	CAP , CHIP	
C1458	CCUS1H270JA	CAP , CHIP	
C1459	CCUS1H270JA	CAP , CHIP	
C1461	CCSJA0J220B	CAP , CHIP TANTAL(A TYPE, 22uF/6.3V, ELNA)	
C1463	CCSJA0J220B	CAP , CHIP TANTAL(A TYPE, 22uF/6.3V, ELNA)	
C1464	CCUS1H104KC	CAP , CHIP	
C1465	CCUS1H104KC	CAP , CHIP	
C1466	CCUS1H104KC	CAP , CHIP	
C1467	CCUS1H104KC	CAP , CHIP	
C1468	CCUS1H104KC	CAP , CHIP	
C1469	CCUS1H104KC	CAP , CHIP	
C1470	CCUS1H104KC	CAP , CHIP	
C1471	CCUS1H104KC	CAP , CHIP	
C1472	CCUS1H104KC	CAP , CHIP	
C1473	CCUS1H104KC	CAP , CHIP	
C1474	CCUS1H104KC	CAP , CHIP	
C1478	CCUS1H104KC	CAP , CHIP	
C1479	CCUS1H104KC	CAP , CHIP	
C1480	CCUS1H104KC	CAP , CHIP	
C1481	CCUS1H104KC	CAP , CHIP	
C1482	CCUS1H104KC	CAP , CHIP	
C1483	CCUS1H104KC	CAP , CHIP	
C1484	CCUS1H104KC	CAP , CHIP	
C1485	CCUS1H104KC	CAP , CHIP	
C1497	CCUS1H104KC	CAP , CHIP	
C1498	CCUS1H104KC	CAP , CHIP	
C1499	CCUS1H104KC	CAP , CHIP	
C1500	CCUS1H104KC	CAP , CHIP	
C1502	CCUS1H104KC	CAP , CHIP	
C1504	CCUS1H104KC	CAP , CHIP	

LOAD No.	PARTS No.	DESCRIPTION	SPECIATION
C1506	CCUS1H104KC	CAP , CHIP	
C1507	CCUS1H104KC	CAP , CHIP	
C1508	CCUS1H104KC	CAP , CHIP	
C1509	CCUS1H104KC	CAP , CHIP	
C1511	CCUS1H104KC	CAP , CHIP	
C1512	CCSJA1C100B	CAP , CHIP TANTAL(A TYPE, 10uF/16V, ELNA)	
C1513	CCUS1H104KC	CAP , CHIP	
C1514	CCUS1H104KC	CAP , CHIP	
C1515	CCUS1H104KC	CAP , CHIP	
C1516	CCSJA1C100B	CAP , CHIP TANTAL(A TYPE, 10uF/16V, ELNA)	
C1517	CCUS1H104KC	CAP , CHIP	
C1518	CCSJA1C100B	CAP , CHIP TANTAL(A TYPE, 10uF/16V, ELNA)	
C1519	CCUS1H104KC	CAP , CHIP	
C1540	CCUS1H470JA	CAP , CHIP	
C1541	CCUS1H470JA	CAP , CHIP	
C1543	CCUI1C104KC	CAP , CHIP(1005, 16V/0.1UF)	
C1544	CCUI1C104KC	CAP , CHIP(1005, 16V/0.1UF)	
C1545	CCSJA0J220B	CAP , CHIP TANTAL(A TYPE, 22uF/6.3V, ELNA)	
C1546	CCUI1C104KC	CAP , CHIP(1005, 16V/0.1UF)	
C1547	CCUS1H103KC	CAP , CHIP	
C1551	CCUS1H104KC	CAP , CHIP	
C1552	CCSJA0J220B	CAP , CHIP TANTAL(A TYPE, 22uF/6.3V, ELNA)	
C1553	CCUS1H104KC	CAP , CHIP	
C1554	CCSJA1C100B	CAP , CHIP TANTAL(A TYPE, 10uF/16V, ELNA)	
C1555	CCUS1H104KC	CAP , CHIP	
C1556	CCSJA0J220B	CAP , CHIP TANTAL(A TYPE, 22uF/6.3V, ELNA)	
C1561	CCUS1H104KC	CAP , CHIP	
C1562	CCSJA0J220B	CAP , CHIP TANTAL(A TYPE, 22uF/6.3V, ELNA)	
C1563	CCUS1H222KC	CAP , CHIP	
C1565	CCSJA1C100B	CAP , CHIP TANTAL(A TYPE, 10uF/16V, ELNA)	
C1568	CCUS1H104KC	CAP , CHIP	
C1569	CCSJA0J220B	CAP , CHIP TANTAL(A TYPE, 22uF/6.3V, ELNA)	
C1570	CCSJA1C100B	CAP , CHIP TANTAL(A TYPE, 10uF/16V, ELNA)	
C1572	CCUS1H104KC	CAP , CHIP	
C1574	CCSJA1C100B	CAP , CHIP TANTAL(A TYPE, 10uF/16V, ELNA)	
C1576	CCSJA1C100B	CAP , CHIP TANTAL(A TYPE, 10uF/16V, ELNA)	
C1578	CCSJA1C100B	CAP , CHIP TANTAL(A TYPE, 10uF/16V, ELNA)	
C1579	CCUS1H104KC	CAP , CHIP	
C1583	CCUS1H104KC	CAP , CHIP	
C1584	CCUS1H104KC	CAP , CHIP	
C1585	CCSJA1C100B	CAP , CHIP TANTAL(A TYPE, 10uF/16V, ELNA)	
C1589	CCSJA1C100B	CAP , CHIP TANTAL(A TYPE, 10uF/16V, ELNA)	
C1590	CCUS1H104KC	CAP , CHIP	
C1591	CCUS1H104KC	CAP , CHIP	
C1592	CCSJA1C100B	CAP , CHIP TANTAL(A TYPE, 10uF/16V, ELNA)	
C1593	CCSJA1C100B	CAP , CHIP TANTAL(A TYPE, 10uF/16V, ELNA)	
C1594	CCUS1H104KC	CAP , CHIP	
C1595	CCUS1H104KC	CAP , CHIP	
C1596	CCSJA1C100B	CAP , CHIP TANTAL(A TYPE, 10uF/16V, ELNA)	
C1601	CCSJA1C100B	CAP , CHIP TANTAL(A TYPE, 10uF/16V, ELNA)	
C1602	CCUS1H104KC	CAP , CHIP	
C1603	CCUS1H104KC	CAP , CHIP	
C1604	CCSJA1C100B	CAP , CHIP TANTAL(A TYPE, 10uF/16V, ELNA)	
C1609	CCSJA1C100B	CAP , CHIP TANTAL(A TYPE, 10uF/16V, ELNA)	
C1610	CCUS1H104KC	CAP , CHIP	
C1611	CCUS1H104KC	CAP , CHIP	
C1612	CCSJA0J220B	CAP , CHIP TANTAL(A TYPE, 22uF/6.3V, ELNA)	
C1613	CCSJA1C100B	CAP , CHIP TANTAL(A TYPE, 10uF/16V, ELNA)	

LOAD No.	PARTS No.	DESCRIPTION	SPECIATION
C1614	CCUS1H104KC	CAP , CHIP	
C1615	CCUS1H104KC	CAP , CHIP	
C1616	CCSJA0J220B	CAP , CHIP TANTAL(A TYPE, 22uF/6.3V, ELNA)	
C1618	CCUS1H104KC	CAP , CHIP	
C1619	CCSJA1C100B	CAP , CHIP TANTAL(A TYPE, 10uF/16V, ELNA)	
C1620	CCUS1H104KC	CAP , CHIP	
C1621	CCUS1H104KC	CAP , CHIP	
C1622	CCSJA0J220B	CAP , CHIP TANTAL(A TYPE, 22uF/6.3V, ELNA)	
C1623	CCSJA1C100B	CAP , CHIP TANTAL(A TYPE, 10uF/16V, ELNA)	
C1624	CCUS1H104KC	CAP , CHIP	
C1625	CCUS1H104KC	CAP , CHIP	
C1626	CCSJA1C100B	CAP , CHIP TANTAL(A TYPE, 10uF/16V, ELNA)	
C1627	CCSJA1C100B	CAP , CHIP TANTAL(A TYPE, 10uF/16V, ELNA)	
C1628	CCUS1H104KC	CAP , CHIP	
C1629	CCUS1H104KC	CAP , CHIP	
C1630	CCSJA1C100B	CAP , CHIP TANTAL(A TYPE, 10uF/16V, ELNA)	
C1631	CCSJA0J220B	CAP , CHIP TANTAL(A TYPE, 22uF/6.3V, ELNA)	
C1632	CCSJA0J220B	CAP , CHIP TANTAL(A TYPE, 22uF/6.3V, ELNA)	
C1633	CCUI1C104KC	CAP , CHIP(1005, 16V/0.1UF)	
C1634	CCUI1C104KC	CAP , CHIP(1005, 16V/0.1UF)	
C1635	CCUI1C104KC	CAP , CHIP(1005, 16V/0.1UF)	
C1636	CCUI1C104KC	CAP , CHIP(1005, 16V/0.1UF)	
C1637	CCUI1C104KC	CAP , CHIP(1005, 16V/0.1UF)	
C1638	CCUI1C104KC	CAP , CHIP(1005, 16V/0.1UF)	
C1639	CCUI1C104KC	CAP , CHIP(1005, 16V/0.1UF)	
C1640	CCUI1C104KC	CAP , CHIP(1005, 16V/0.1UF)	
C1641	CCUI1C104KC	CAP , CHIP(1005, 16V/0.1UF)	
C1642	CCUI1C104KC	CAP , CHIP(1005, 16V/0.1UF)	
C1643	CCUI1C104KC	CAP , CHIP(1005, 16V/0.1UF)	
C1644	CCUI1C104KC	CAP , CHIP(1005, 16V/0.1UF)	
C1645	CCUI1C104KC	CAP , CHIP(1005, 16V/0.1UF)	
C1646	CCSJA1C100B	CAP , CHIP TANTAL(A TYPE, 10uF/16V, ELNA)	
C1647	CCUI1C104KC	CAP , CHIP(1005, 16V/0.1UF)	
C1648	CCUI1C104KC	CAP , CHIP(1005, 16V/0.1UF)	
C1649	CCUI1C104KC	CAP , CHIP(1005, 16V/0.1UF)	
C1650	CCUI1C104KC	CAP , CHIP(1005, 16V/0.1UF)	
C1651	CCSJA1C100B	CAP , CHIP TANTAL(A TYPE, 10uF/16V, ELNA)	
C1653	CCUI1C104KC	CAP , CHIP(1005, 16V/0.1UF)	
C1654	CCUI1C104KC	CAP , CHIP(1005, 16V/0.1UF)	
C1655	CCSJA1C100B	CAP , CHIP TANTAL(A TYPE, 10uF/16V, ELNA)	
C1656	CCUI1C104KC	CAP , CHIP(1005, 16V/0.1UF)	
C1657	CCUI1C104KC	CAP , CHIP(1005, 16V/0.1UF)	
C1658	CCUI1C104KC	CAP , CHIP(1005, 16V/0.1UF)	
C1659	CCUI1C104KC	CAP , CHIP(1005, 16V/0.1UF)	
C1660	CCUI1C104KC	CAP , CHIP(1005, 16V/0.1UF)	
C1661	CCUI1C104KC	CAP , CHIP(1005, 16V/0.1UF)	
C1662	CCSJA0J220B	CAP , CHIP TANTAL(A TYPE, 22uF/6.3V, ELNA)	
C1663	CCUI1C104KC	CAP , CHIP(1005, 16V/0.1UF)	
C1664	CCUI1C104KC	CAP , CHIP(1005, 16V/0.1UF)	
C1665	CCUI1C104KC	CAP , CHIP(1005, 16V/0.1UF)	
C1666	CCSJA1C100B	CAP , CHIP TANTAL(A TYPE, 10uF/16V, ELNA)	
C1668	CCSJA1C100B	CAP , CHIP TANTAL(A TYPE, 10uF/16V, ELNA)	
C1669	CCUI1C104KC	CAP , CHIP(1005, 16V/0.1UF)	
C1670	CCUI1C104KC	CAP , CHIP(1005, 16V/0.1UF)	
C1671	CCSJA1C100B	CAP , CHIP TANTAL(A TYPE, 10uF/16V, ELNA)	
C1672	CCSJA1C100B	CAP , CHIP TANTAL(A TYPE, 10uF/16V, ELNA)	
C1673	CCUI1C104KC	CAP , CHIP(1005, 16V/0.1UF)	
C1674	CCUI1C104KC	CAP , CHIP(1005, 16V/0.1UF)	

LOAD No.	PARTS No.	DESCRIPTION	SPECIATION
C1675	CCUI1C104KC	CAP , CHIP(1005, 16V/0.1UF)	
C1676	CCUI1C104KC	CAP , CHIP(1005, 16V/0.1UF)	
C1677	CCUI1C104KC	CAP , CHIP(1005, 16V/0.1UF)	
C1678	CCUI1C104KC	CAP , CHIP(1005, 16V/0.1UF)	
C1679	CCUI1C104KC	CAP , CHIP(1005, 16V/0.1UF)	
C1680	CCUI1C104KC	CAP , CHIP(1005, 16V/0.1UF)	
C1681	CCUI1C104KC	CAP , CHIP(1005, 16V/0.1UF)	
C1682	CCUI1C104KC	CAP , CHIP(1005, 16V/0.1UF)	
C1683	CCUI1C104KC	CAP , CHIP(1005, 16V/0.1UF)	
C1684	CCUI1C104KC	CAP , CHIP(1005, 16V/0.1UF)	
C1685	CCUI1C104KC	CAP , CHIP(1005, 16V/0.1UF)	
C1686	CCUI1C104KC	CAP , CHIP(1005, 16V/0.1UF)	
C1687	CCUI1C104KC	CAP , CHIP(1005, 16V/0.1UF)	
C1688	CCUI1C104KC	CAP , CHIP(1005, 16V/0.1UF)	
C1689	CCUI1C104KC	CAP , CHIP(1005, 16V/0.1UF)	
C1690	CCSJA1C100B	CAP , CHIP TANTAL(A TYPE, 10uF/16V, ELNA)	
C1691	CCSJA1C100B	CAP , CHIP TANTAL(A TYPE, 10uF/16V, ELNA)	
C1692	CCUI1C104KC	CAP , CHIP(1005, 16V/0.1UF)	
C1693	CCUS1H103KC	CAP , CHIP	
C1694	CCUI1C104KC	CAP , CHIP(1005, 16V/0.1UF)	
C1695	CCUS1H103KC	CAP , CHIP	
C1696	CCUI1C104KC	CAP , CHIP(1005, 16V/0.1UF)	
C1697	CCUI1C104KC	CAP , CHIP(1005, 16V/0.1UF)	
C1698	CCUI1C104KC	CAP , CHIP(1005, 16V/0.1UF)	
C1699	CCUI1C104KC	CAP , CHIP(1005, 16V/0.1UF)	
C1700	CCUS1H103KC	CAP , CHIP	
C1701	CCUI1C104KC	CAP , CHIP(1005, 16V/0.1UF)	
C1702	CCUS1H103KC	CAP , CHIP	
C1703	CCUI1C104KC	CAP , CHIP(1005, 16V/0.1UF)	
C1704	CCUS1H103KC	CAP , CHIP	
C1705	CCUI1C104KC	CAP , CHIP(1005, 16V/0.1UF)	
C1706	CCUI1C104KC	CAP , CHIP(1005, 16V/0.1UF)	
C1709	CCUS1H103KC	CAP , CHIP	
C1710	CCUS1H103KC	CAP , CHIP	
C1711	CCUI1C104KC	CAP , CHIP(1005, 16V/0.1UF)	
C1712	CCUS1H103KC	CAP , CHIP	
C1713	CCUI1C104KC	CAP , CHIP(1005, 16V/0.1UF)	
C1714	CCUI1C104KC	CAP , CHIP(1005, 16V/0.1UF)	
C1715	CCUI1C104KC	CAP , CHIP(1005, 16V/0.1UF)	
C1716	CCUI1C104KC	CAP , CHIP(1005, 16V/0.1UF)	
C1717	CCUS1H103KC	CAP , CHIP	
C1718	CCUI1C104KC	CAP , CHIP(1005, 16V/0.1UF)	
C1719	CCUS1H103KC	CAP , CHIP	
C1720	CCUI1C104KC	CAP , CHIP(1005, 16V/0.1UF)	
C1721	CCUS1H103KC	CAP , CHIP	
C1722	CCUS1H103KC	CAP , CHIP	
C1724	CCUI1C104KC	CAP , CHIP(1005, 16V/0.1UF)	
C1728	CCUS1H104KC	CAP , CHIP	
C1729	CCUS1H104KC	CAP , CHIP	
D1401	CVD1SS378	DIODE , SCHOTTKY BARRIER	
D1402	HVD1SR159-200	DIODE , RECTIFIER	
IC165	CVIKIA1117S33	I.C , REGULATOR(SOT-223)	
IC167	CVIKIA1117S18	I.C , REGULATOR(SOT-223)	
L1404	CLZ9Z014Z	FERRITE , CHIP BEAD(60ohm, 4516)	
L1405	CLZ9Z014Z	FERRITE , CHIP BEAD(60ohm, 4516)	
L1409	CLZ9R005Z	FERRITE , CHIP BEAD(60ohm, 1608)	
L1410	CLZ9R005Z	FERRITE , CHIP BEAD(60ohm, 1608)	
L1411	CLZ9Z014Z	FERRITE , CHIP BEAD(60ohm, 4516)	

LOAD No.	PARTS No.	DESCRIPTION	SPECIATION
L1412	CLZ9Z014Z	FERRITE , CHIP BEAD(60ohm, 4516)	
L1413	CLZ9Z014Z	FERRITE , CHIP BEAD(60ohm, 4516)	
L1414	CLZ9Z014Z	FERRITE , CHIP BEAD(60ohm, 4516)	
L1415	CLZ9R005Z	FERRITE , CHIP BEAD(60ohm, 1608)	
L1416	CLZ9R005Z	FERRITE , CHIP BEAD(60ohm, 1608)	
L1418	CLZ9R005Z	FERRITE , CHIP BEAD(60ohm, 1608)	
L1419	CLZ9Z014Z	FERRITE , CHIP BEAD(60ohm, 4516)	
L1421	CLZ9R005Z	FERRITE , CHIP BEAD(60ohm, 1608)	
L1422	CLZ9R005Z	FERRITE , CHIP BEAD(60ohm, 1608)	
L1428	CLZ9R005Z	FERRITE , CHIP BEAD(60ohm, 1608)	
L1429	CLZ9R005Z	FERRITE , CHIP BEAD(60ohm, 1608)	
L1430	CLZ9R005Z	FERRITE , CHIP BEAD(60ohm, 1608)	
L1431	CLZ9R005Z	FERRITE , CHIP BEAD(60ohm, 1608)	
L1432	CLZ9R005Z	FERRITE , CHIP BEAD(60ohm, 1608)	
L1434	CLZ9R005Z	FERRITE , CHIP BEAD(60ohm, 1608)	
L1440	CLZ9R005Z	FERRITE , CHIP BEAD(60ohm, 1608)	
Q1401	HVTKRA102S	T.R , CHIP	
Q1402	CVTKRC103S	T.R , CHIP	
Q1403	CVTUPA672T	F.E.T	
Q1404	HVTKRA102S	T.R , CHIP	
Q1405	CVTKRC103S	T.R , CHIP	
Q1406	CVTUPA672T	F.E.T	
Q1407	HVTKRA102S	T.R , CHIP	
Q1408	CVTKRC103S	T.R , CHIP	
Q1409	CVTUPA672T	F.E.T	
Q1413	CVTKRC103S	T.R , CHIP	
Q1414	HVTKRC111S	TR , CHIP	
Q1415	CVTKRC103S	T.R , CHIP	
RN166	CRJ104DJ103T	RES, ARRAY, 10K (1608)	
RN167	CRJ104DJ103T	RES, ARRAY, 10K (1608)	
RN171	CRJ062IJ330T	RES , CHIP NETWORK(1/16W, 33ohm, 1005X2)	
RN172	CRJ064IJ330T	RES , CHIP NETWORK(1/16W, 33ohm, 1005X4)	
RN173	CRJ064IJ330T	RES , CHIP NETWORK(1/16W, 33ohm, 1005X4)	
RN174	CRJ064IJ330T	RES , CHIP NETWORK(1/16W, 33ohm, 1005X4)	
RN178	CRJ064IJ330T	RES , CHIP NETWORK(1/16W, 33ohm, 1005X4)	
RN179	CRJ064IJ330T	RES , CHIP NETWORK(1/16W, 33ohm, 1005X4)	
RN196	CRJ104DJ220T	RES,4ARRAY	
R1401	CRJ10DJ223T	RES , CHIP	
R1402	CRJ10DJ102T	RES , CHIP	
R1403	CRJ10DJ101T	RES , CHIP	
R1404	CRJ10DJ473T	RES , CHIP	
R1405	CRJ10DJ470T	RES , CHIP	
R1406	CRJ10DJ470T	RES , CHIP	
R1407	CRJ10DJ473T	RES , CHIP	
R1408	CRJ10DJ103T	RES , CHIP	
R1409	CRJ10DJ103T	RES , CHIP	
R1410	CRJ10DJ473T	RES , CHIP	
R1411	CRJ10DJ223T	RES , CHIP	
R1412	CRJ10DJ102T	RES , CHIP	
R1413	CRJ10DJ101T	RES , CHIP	
R1414	CRJ10DJ473T	RES , CHIP	
R1415	CRJ10DJ470T	RES , CHIP	
R1416	CRJ10DJ470T	RES , CHIP	
R1417	CRJ10DJ473T	RES , CHIP	
R1418	CRJ10DJ103T	RES , CHIP	
R1419	CRJ10DJ103T	RES , CHIP	
R1420	CRJ10DJ473T	RES , CHIP	
R1421	CRJ10DJ223T	RES , CHIP	

LOAD No.	PARTS No.	DESCRIPTION	SPECIATION
R1422	CRJ10DJ102T	RES , CHIP	
R1423	CRJ10DJ101T	RES , CHIP	
R1424	CRJ10DJ473T	RES , CHIP	
R1425	CRJ10DJ470T	RES , CHIP	
R1426	CRJ10DJ470T	RES , CHIP	
R1427	CRJ10DJ473T	RES , CHIP	
R1428	CRJ10DJ103T	RES , CHIP	
R1429	CRJ10DJ103T	RES , CHIP	
R1430	CRJ10DJ473T	RES , CHIP	
R1431	CRJ10DJ223T	RES , CHIP	
R1432	CRJ10DJ102T	RES , CHIP	
R1433	CRJ10DJ101T	RES , CHIP	
R1434	CRJ10DJ473T	RES , CHIP	
R1435	CRJ10DJ470T	RES , CHIP	
R1436	CRJ10DJ470T	RES , CHIP	
R1437	CRJ10DJ103T	RES , CHIP	
R1438	CRJ10DJ473T	RES , CHIP	
R1439	CRJ10DJ473T	RES , CHIP	
R1440	CRJ10DJ103T	RES , CHIP	
R1441	CRJ10DJ103T	RES , CHIP	
R1444	CRJ10DJ102T	RES , CHIP	
R1445	CRJ10DJ102T	RES , CHIP	
R1446	CRJ10DJ102T	RES , CHIP	
R1447	CRJ10DJ103T	RES , CHIP	
R1448	CRJ10DJ0R0T	RES , CHIP	
R1456	CRJ10DJ101T	RES , CHIP	
R1457	CRJ10DJ101T	RES , CHIP	
R1465	CRJ10DJ103T	RES , CHIP	
R1466	CRJ10DJ103T	RES , CHIP	
R1467	CRJ10DJ473T	RES , CHIP	
R1468	CRJ10DJ221T	RES , CHIP	
R1469	CRJ10DJ105T	RES , CHIP	
R1470	CRJ10DJ472T	RES , CHIP	
R1471	CRJ10DJ473T	RES , CHIP	
R1473	CRJ10DJ101T	RES , CHIP	
R1474	CRJ10DJ101T	RES , CHIP	
R1475	CRJ10DJ102T	RES , CHIP	
R1476	CRJ10DJ473T	RES , CHIP	
R1477	CRJ10DJ473T	RES , CHIP	
R1478	CRJ10DJ103T	RES , CHIP	
R1484	CRJ10DJ103T	RES , CHIP	
R1490	CRJ10DJ472T	RES , CHIP	
R1498	CRJ10DJ182T	RES , CHIP	
R1499	CRJ10DJ103T	RES , CHIP	
R1500	CRJ10DJ103T	RES , CHIP	
R1501	CRJ10DJ182T	RES , CHIP	
R1534	CRJ10DJ222T	RES , CHIP	
R1535	CRJ10DJ272T	RES , CHIP	
R1536	CRJ10DJ272T	RES , CHIP	
R1537	CRJ10DJ473T	RES , CHIP	
R1538	CRJ10DF2800T	RES , CHIP(1/10W, 280ohm, 1608, 1%)	
R1539	CRJ10DF2800T	RES , CHIP(1/10W, 280ohm, 1608, 1%)	
R1541	CRJ10DJ103T	RES , CHIP	
R1542	CRJ10DJ103T	RES , CHIP	
R1543	CRJ10DJ103T	RES , CHIP	
R1544	CRJ10DJ103T	RES , CHIP	
R1545	CRJ10DJ103T	RES , CHIP	
R1546	CRJ10DJ103T	RES , CHIP	

LOAD No.	PARTS No.	DESCRIPTION	SPECIATION
R1547	CRJ10DJ103T	RES , CHIP	
R1548	CRJ10DJ0R0T	RES , CHIP	
R1549	CRJ10DJ103T	RES , CHIP	
R1552	CRJ10DJ100T	RES , CHIP	
R1571	CRJ10DJ103T	RES , CHIP	
R1581	CRJ10DF1002T	RES , CHIP 1%	
R1586	CRJ10DJ220T	RES , CHIP	
R1587	CRJ10DJ220T	RES , CHIP	
R1593	CRJ10DJ220T	RES , CHIP	
R1594	CRJ10DJ220T	RES , CHIP	
R1595	CRJ10DJ220T	RES , CHIP	
R1596	CRJ10DJ220T	RES , CHIP	
R1597	CRJ10DJ220T	RES , CHIP	
R1598	CRJ10DJ220T	RES , CHIP	
R1599	CRJ10DJ220T	RES , CHIP	
R1602	CRJ10DJ0R0T	RES , CHIP	
R1610	CRJ10DJ0R0T	RES , CHIP	
R1611	CRJ10DJ0R0T	RES , CHIP	
R1612	CRJ10DJ0R0T	RES , CHIP	
R1615	CRJ10DJ0R0T	RES , CHIP	
R1617	CRJ10DJ101T	RES , CHIP	
R1621	CRJ10DJ0R0T	RES , CHIP	
	CIP12120DTSMD	T747AH HDMI PCB TOP SMD ASS'Y	
C1453	CCUS1H104KC	CAP , CHIP	
C1460	CCUS1H104KC	CAP , CHIP	
C1462	CCUS1H104KC	CAP , CHIP	
C1475	CCSJA0J220B	CAP , CHIP TANTAL(A TYPE, 22uF/6.3V, ELNA)	
C1476	CCSJA1C100B	CAP , CHIP TANTAL(A TYPE, 10uF/16V, ELNA)	
C1477	CCUS1H104KC	CAP , CHIP	
C1488	CCUS1H104KC	CAP , CHIP	
C1489	CCSJA1C100B	CAP , CHIP TANTAL(A TYPE, 10uF/16V, ELNA)	
C1490	CCUS1H104KC	CAP , CHIP	
C1491	CCUS1H104KC	CAP , CHIP	
C1492	CCSJA0J220B	CAP , CHIP TANTAL(A TYPE, 22uF/6.3V, ELNA)	
C1493	CCUS1H104KC	CAP , CHIP	
C1494	CCSJA0J220B	CAP , CHIP TANTAL(A TYPE, 22uF/6.3V, ELNA)	
C1495	CCUS1H104KC	CAP , CHIP	
C1496	CCSJA0J220B	CAP , CHIP TANTAL(A TYPE, 22uF/6.3V, ELNA)	
C1501	CCSJA0J220B	CAP , CHIP TANTAL(A TYPE, 22uF/6.3V, ELNA)	
C1503	CCSJA1C100B	CAP , CHIP TANTAL(A TYPE, 10uF/16V, ELNA)	
C1510	CCSJA1C100B	CAP , CHIP TANTAL(A TYPE, 10uF/16V, ELNA)	
C1520	CCUS1H104KC	CAP , CHIP	
C1521	CCUS1H104KC	CAP , CHIP	
C1522	CCUS1H104KC	CAP , CHIP	
C1523	CCUS1H104KC	CAP , CHIP	
C1524	CCUS1H104KC	CAP , CHIP	
C1525	CCUS1H104KC	CAP , CHIP	
C1526	CCUS1H104KC	CAP , CHIP	
C1527	CCUS1H104KC	CAP , CHIP	
C1528	CCUS1H104KC	CAP , CHIP	
C1529	CCUS1H104KC	CAP , CHIP	
C1530	CCUS1H104KC	CAP , CHIP	
C1531	CCUS1H104KC	CAP , CHIP	
C1532	CCUS1H104KC	CAP , CHIP	
C1533	CCUS1H104KC	CAP , CHIP	
C1534	CCUS1H104KC	CAP , CHIP	
C1535	CCUS1H104KC	CAP , CHIP	
C1536	CCUS1H104KC	CAP , CHIP	

LOAD No.	PARTS No.	DESCRIPTION	SPECIATION
C1537	CCUS1H104KC	CAP , CHIP	
C1538	CCUS1H104KC	CAP , CHIP	
C1539	CCUS1H104KC	CAP , CHIP	
C1557	CCUS1H123KC	CAP , CHIP(1608, 50V/12NF)	
C1558	CCUS1C154KC	CAP , CHIP	
C1559	CCUS1C154KC	CAP , CHIP	
C1560	CCUS1H123KC	CAP , CHIP(1608, 50V/12NF)	
C1564	CCUS1H104KC	CAP , CHIP	
C1566	CCUS1H104KC	CAP , CHIP	
C1567	CCUS1H222KC	CAP , CHIP	
C1571	CCUS1H104KC	CAP , CHIP	
C1573	CCUS1A105KC	CAP , CHIP	
C1575	CCUS1A105KC	CAP , CHIP	
C1577	CCUS1H104KC	CAP , CHIP	
C1580	CCUS1H104KC	CAP , CHIP	
C1581	CCUS1H104KC	CAP , CHIP	
C1582	CCSJA1C100B	CAP , CHIP TANTAL(A TYPE, 10uF/16V, ELNA)	
C1597	CCSJA1C100B	CAP , CHIP TANTAL(A TYPE, 10uF/16V, ELNA)	
C1598	CCUS1H104KC	CAP , CHIP	
C1599	CCUS1H104KC	CAP , CHIP	
C1600	CCSJA1C100B	CAP , CHIP TANTAL(A TYPE, 10uF/16V, ELNA)	
C1605	CCSJA1C100B	CAP , CHIP TANTAL(A TYPE, 10uF/16V, ELNA)	
C1606	CCUS1H104KC	CAP , CHIP	
C1607	CCUS1H104KC	CAP , CHIP	
C1608	CCSJA0J220B	CAP , CHIP TANTAL(A TYPE, 22uF/6.3V, ELNA)	
C1617	CCSJA1C100B	CAP , CHIP TANTAL(A TYPE, 10uF/16V, ELNA)	
C1652	CCU1C104KC	CAP , CHIP(1005, 16V/0.1UF)	
C1667	CCU1C104KC	CAP , CHIP(1005, 16V/0.1UF)	
C1707	CCSJA0J220B	CAP , CHIP TANTAL(A TYPE, 22uF/6.3V, ELNA)	
C1708	CCSJA0J220B	CAP , CHIP TANTAL(A TYPE, 22uF/6.3V, ELNA)	
C1723	CCSJA0J220B	CAP , CHIP TANTAL(A TYPE, 22uF/6.3V, ELNA)	
C1725	CCUS1H103KC	CAP , CHIP	
C1730	CCUS1H104KC	CAP , CHIP	
D1403	HVD1SR159-200	DIODE , RECTIFIER	
D1405	HVD1SR159-200	DIODE , RECTIFIER	
D1406	HVD1SR159-200	DIODE , RECTIFIER	
D1407	HVD1SR159-200	DIODE , RECTIFIER	
D1408	HVD1SR159-200	DIODE , RECTIFIER	
D1409	HVD1SR159-200	DIODE , RECTIFIER	
D1410	HVD1SR159-200	DIODE , RECTIFIER	
D1411	HVD1SR159-200	DIODE , RECTIFIER	
D1412	HVD1SR159-200	DIODE , RECTIFIER	
IC141	CVISII9185ACTU	I.C , HDMI RX SW(80PIN TQFP)	
IC142	CVITC7MZ4052FK	I.C , 4CH MUX	
IC143	CVIAT24C02NSU18	I.C , EEPROM (2K)	
IC144	CVITC74VHCT14AFT	I.C , HEX SCHMITT INVERTER(14PIN, TSSOP)	
IC145	CVITC74VHCT14AFT	I.C , HEX SCHMITT INVERTER(14PIN, TSSOP)	
IC146	CVISII9135CTU	IC , HDMI RX(144PIN, TQFP)	
IC147	CVITC74VCX541FT	I,C , OCTAL BUS BUFFER	
IC148	HVIKIC7SZ08FU	I.C ,INPUT AND GATE (USV PACKAGE)	
IC149	CVIKIA1117S50	I.C , REGULATOR(SOT-223)	
IC150	CVIKIA1117S50	I.C , REGULATOR(SOT-223)	
IC151	CVIFLI30336AC	I.C , VIDEO PROCESSOR	
IC152	CVIES29LV320ET70TG	I.C , FLASH ROM 32Mbit IC (TOP BOOST)	
IC152	CVIES29LV320FT70TG	I.C , FLASH ROM 32Mbit IC (TOP BOOST)	
IC153	CVIA3S56D40ETPG5	I.C, 256MB DDR SDRAM	
IC154	CVIA3S56D40ETPG5	I.C, 256MB DDR SDRAM	
IC155	HVIKIC7SZ08FU	I.C ,INPUT AND GATE (USV PACKAGE)	

LOAD No.	PARTS No.	DESCRIPTION	SPECIATION
IC156	CVIM24C32WMN6TP	I.C , EEPROM (32 Kbit)	
IC158	CVIADV7342BSTZ	I.C , VIDEO ENCODER	
IC159	CVINJM2566V	I.C , NJM2566AV(TE1)	
IC160	CVIMK2302S01T	I.C , BUFFER	
IC161	CVIKIA1117S33	I.C , REGULATOR(SOT-223)	
IC162	CVIKIA1117S18	I.C , REGULATOR(SOT-223)	
IC163	CVIKIA1117S25	I.C , REGULATOR(SOT-223)	
IC164	CVIKIA1117S33	I.C , REGULATOR(SOT-223)	
IC166	CVIKIA1117S33	I.C , REGULATOR(SOT-223)	
IC168	CVIKIA1117S18	I.C , REGULATOR(SOT-223)	
IC169	CVIKIA1117S18	I.C , REGULATOR(SOT-223)	
IC170	CVIKIA1117S33	I.C , REGULATOR(SOT-223)	
IC171	CVIKIA1117S18	I.C , REGULATOR(SOT-223)	
IC173	CVISII9134CTU	IC , HDMI TX(100PIN, TQFP)	
JK140	HJJ9H003Z	JACK , HDMI(JALCO)	
JK141	HJJ9H003Z	JACK , HDMI(JALCO)	
JK142	HJJ9H003Z	JACK , HDMI(JALCO)	
JK143	HJJ9H003Z	JACK , HDMI(JALCO)	
JK144	HJJ9H003Z	JACK , HDMI(JALCO)	
L1401	CLZ9Z014Z	FERRITE , CHIP BEAD(60ohm, 4516)	
L1402	CLZ9R005Z	FERRITE , CHIP BEAD(60ohm, 1608)	
L1403	CLZ9Z014Z	FERRITE , CHIP BEAD(60ohm, 4516)	
L1406	CLZ9R005Z	FERRITE , CHIP BEAD(60ohm, 1608)	
L1407	CLZ9R005Z	FERRITE , CHIP BEAD(60ohm, 1608)	
L1408	CLZ9R005Z	FERRITE , CHIP BEAD(60ohm, 1608)	
L1417	CLZ9R005Z	FERRITE , CHIP BEAD(60ohm, 1608)	
L1420	CLZ9Z014Z	FERRITE , CHIP BEAD(60ohm, 4516)	
L1423	CLZ9R005Z	FERRITE , CHIP BEAD(60ohm, 1608)	
L1424	CLZ9Z014Z	FERRITE , CHIP BEAD(60ohm, 4516)	
L1425	CLZ9Z014Z	FERRITE , CHIP BEAD(60ohm, 4516)	
L1426	CLZ9R005Z	FERRITE , CHIP BEAD(60ohm, 1608)	
L1427	CLZ9R005Z	FERRITE , CHIP BEAD(60ohm, 1608)	
L1433	CLZ9R005Z	FERRITE , CHIP BEAD(60ohm, 1608)	
L1435	CLZ9Z014Z	FERRITE , CHIP BEAD(60ohm, 4516)	
L1436	CLZ9Z014Z	FERRITE , CHIP BEAD(60ohm, 4516)	
L1437	CLZ9Z014Z	FERRITE , CHIP BEAD(60ohm, 4516)	
L1438	CLZ9Z014Z	FERRITE , CHIP BEAD(60ohm, 4516)	
L1439	CLZ9Z014Z	FERRITE , CHIP BEAD(60ohm, 4516)	
OL140	BLZ9R004Z	BEAD CHIP 90 OHM (2012 SIZE)	BEAD
OL141	BLZ9R004Z	BEAD CHIP 90 OHM (2012 SIZE)	BEAD
OL142	BLZ9R004Z	BEAD CHIP 90 OHM (2012 SIZE)	BEAD
OL143	BLZ9R004Z	BEAD CHIP 90 OHM (2012 SIZE)	BEAD
Q1410	HVTKRA102S	T.R , CHIP	
Q1411	CVTKRC103S	T.R , CHIP	
Q1412	CVTUPA672T	F.E.T	
Q1416	CVTUPA672T	F.E.T	
Q1419	HVTKRC102S	T.R , CHIP	
RN140	CRJ064IJ330T	RES , CHIP NETWORK(1/16W, 33ohm, 1005X4)	
RN141	CRJ064IJ330T	RES , CHIP NETWORK(1/16W, 33ohm, 1005X4)	
RN142	CRJ064IJ330T	RES , CHIP NETWORK(1/16W, 33ohm, 1005X4)	
RN143	CRJ064IJ330T	RES , CHIP NETWORK(1/16W, 33ohm, 1005X4)	
RN146	CRJ064IJ330T	RES , CHIP NETWORK(1/16W, 33ohm, 1005X4)	
RN147	CRJ064IJ330T	RES , CHIP NETWORK(1/16W, 33ohm, 1005X4)	
RN148	CRJ064IJ330T	RES , CHIP NETWORK(1/16W, 33ohm, 1005X4)	
RN149	CRJ064IJ330T	RES , CHIP NETWORK(1/16W, 33ohm, 1005X4)	
RN150	CRJ064IJ330T	RES , CHIP NETWORK(1/16W, 33ohm, 1005X4)	
RN151	CRJ064IJ330T	RES , CHIP NETWORK(1/16W, 33ohm, 1005X4)	
RN152	CRJ104DJ220T	RES,4ARRAY	

LOAD No.	PARTS No.	DESCRIPTION	SPECIATION
RN153	CRJ104DJ220T	RES,4ARRAY	
RN154	CRJ064IJ330T	RES , CHIP NETWORK(1/16W, 33ohm, 1005X4)	
RN156	CRJ064IJ330T	RES , CHIP NETWORK(1/16W, 33ohm, 1005X4)	
RN157	CRJ064IJ330T	RES , CHIP NETWORK(1/16W, 33ohm, 1005X4)	
RN158	CRJ064IJ330T	RES , CHIP NETWORK(1/16W, 33ohm, 1005X4)	
RN159	CRJ064IJ330T	RES , CHIP NETWORK(1/16W, 33ohm, 1005X4)	
RN160	CRJ064IJ330T	RES , CHIP NETWORK(1/16W, 33ohm, 1005X4)	
RN161	CRJ064IJ330T	RES , CHIP NETWORK(1/16W, 33ohm, 1005X4)	
RN162	CRJ064IJ330T	RES , CHIP NETWORK(1/16W, 33ohm, 1005X4)	
RN163	CRJ064IJ330T	RES , CHIP NETWORK(1/16W, 33ohm, 1005X4)	
RN164	CRJ064IJ330T	RES , CHIP NETWORK(1/16W, 33ohm, 1005X4)	
RN168	CRJ064IJ330T	RES , CHIP NETWORK(1/16W, 33ohm, 1005X4)	
RN169	CRJ064IJ330T	RES , CHIP NETWORK(1/16W, 33ohm, 1005X4)	
RN170	CRJ062IJ330T	RES , CHIP NETWORK(1/16W, 33ohm, 1005X2)	
RN175	CRJ064IJ330T	RES , CHIP NETWORK(1/16W, 33ohm, 1005X4)	
RN176	CRJ064IJ330T	RES , CHIP NETWORK(1/16W, 33ohm, 1005X4)	
RN177	CRJ062IJ330T	RES , CHIP NETWORK(1/16W, 33ohm, 1005X2)	
RN180	CRJ062IJ330T	RES , CHIP NETWORK(1/16W, 33ohm, 1005X2)	
RN181	CRJ064IJ330T	RES , CHIP NETWORK(1/16W, 33ohm, 1005X4)	
RN182	CRJ064IJ330T	RES , CHIP NETWORK(1/16W, 33ohm, 1005X4)	
RN183	CRJ062IJ330T	RES , CHIP NETWORK(1/16W, 33ohm, 1005X2)	
RN184	CRJ064IJ330T	RES , CHIP NETWORK(1/16W, 33ohm, 1005X4)	
RN185	CRJ064IJ330T	RES , CHIP NETWORK(1/16W, 33ohm, 1005X4)	
RN186	CRJ064IJ330T	RES , CHIP NETWORK(1/16W, 33ohm, 1005X4)	
RN187	CRJ104DJ100T	RES, ARRAY, 10R (1608)	
RN188	CRJ104DJ100T	RES, ARRAY, 10R (1608)	
RN189	CRJ104DJ100T	RES, ARRAY, 10R (1608)	
RN190	CRJ104DJ100T	RES, ARRAY, 10R (1608)	
RN191	CRJ104DJ100T	RES, ARRAY, 10R (1608)	
RN192	CRJ104DJ100T	RES, ARRAY, 10R (1608)	
RN193	CRJ104DJ100T	RES, ARRAY, 10R (1608)	
R1455	CRJ10DJ0R0T	RES , CHIP	
R1459	CRJ10DJ432T	RES , CHIP	
R1460	CRJ10DJ432T	RES , CHIP	
R1461	CRJ10DJ101T	RES , CHIP	
R1462	CRJ10DJ101T	RES , CHIP	
R1463	CRJ10DJ0R0T	RES , CHIP	
R1464	CRJ10DJ0R0T	RES , CHIP	
R1480	CRJ10DJ101T	RES , CHIP	
R1481	CRJ10DJ102T	RES , CHIP	
R1482	CRJ10DF8200T	RES , CHIP 1% 820 OHM	
R1483	CRJ10DF1002T	RES , CHIP 1%	
R1485	CRJ10DJ101T	RES , CHIP	
R1486	CRJ10DJ101T	RES , CHIP	
R1488	CRJ10DJ472T	RES , CHIP	
R1489	CRJ10DJ101T	RES , CHIP	
R1491	CRJ10DJ103T	RES , CHIP	
R1492	CRJ10DJ103T	RES , CHIP	
R1493	CRJ10DJ220T	RES , CHIP	
R1494	CRJ10DJ103T	RES , CHIP	
R1495	CRJ10DJ103T	RES , CHIP	
R1496	CRJ10DJ103T	RES , CHIP	
R1497	CRJ10DJ103T	RES , CHIP	
R1502	CRJ10DJ473T	RES , CHIP	
R1503	CRJ10DJ101T	RES , CHIP	
R1504	CRJ10DJ220T	RES , CHIP	
R1505	CRJ10DJ220T	RES , CHIP	
R1506	CRJ10DJ220T	RES , CHIP	

LOAD No.	PARTS No.	DESCRIPTION	SPECIATION
R1507	CRJ10DJ220T	RES , CHIP	
R1508	CRJ10DJ560T	RES , CHIP	
R1509	CRJ10DJ560T	RES , CHIP	
R1510	CRJ10DJ560T	RES , CHIP	
R1511	CRJ10DJ220T	RES , CHIP	
R1512	CRJ10DJ220T	RES , CHIP	
R1513	CRJ10DJ560T	RES , CHIP	
R1514	CRJ10DJ560T	RES , CHIP	
R1515	CRJ10DJ220T	RES , CHIP	
R1516	CRJ10DJ220T	RES , CHIP	
R1517	CRJ10DJ220T	RES , CHIP	
R1518	CRJ10DJ560T	RES , CHIP	
R1519	CRJ10DJ560T	RES , CHIP	
R1520	CRJ10DJ220T	RES , CHIP	
R1521	CRJ10DJ220T	RES , CHIP	
R1522	CRJ10DJ220T	RES , CHIP	
R1523	CRJ10DJ560T	RES , CHIP	
R1524	CRJ10DJ103T	RES , CHIP	
R1525	CRJ10DJ103T	RES , CHIP	
R1527	CRJ10DJ103T	RES , CHIP	
R1532	CRJ10DJ103T	RES , CHIP	
R1533	CRJ10DJ103T	RES , CHIP	
R1550	CRJ10DJ100T	RES , CHIP	
R1551	CRJ10DJ472T	RES , CHIP	
R1553	CRJ10DJ151T	RES , CHIP	
R1554	CRJ10DJ200T	RES , CHIP(1/10W, 200HM,1608)	
R1555	CRJ10DJ151T	RES , CHIP	
R1556	CRJ10DJ200T	RES , CHIP(1/10W, 200HM,1608)	
R1557	CRJ10DJ392T	RES . CHIP	
R1558	CRJ10DJ221T	RES , CHIP	
R1559	CRJ10DJ221T	RES , CHIP	
R1560	CRJ10DJ392T	RES . CHIP	
R1561	CRJ10DF4301T	RES , CHIP	
R1564	CRJ10DF6801T	RES, CHIP 6.8KOHM/1608/1%	
R1565	CRJ10DJ301T	RES , CHIP	
R1566	CRJ10DJ301T	RES , CHIP	
R1567	CRJ10DJ301T	RES , CHIP	
R1568	CRJ10DJ301T	RES , CHIP	
R1569	CRJ10DJ301T	RES , CHIP	
R1570	CRJ10DJ301T	RES , CHIP	
R1572	CRJ10DJ103T	RES , CHIP	
R1573	CRJ10DJ103T	RES , CHIP	
R1574	CRJ10DJ103T	RES , CHIP	
R1575	CRJ10DJ750T	RES , CHIP	
R1576	CRJ10DJ750T	RES , CHIP	
R1577	CRJ10DJ750T	RES , CHIP	
R1578	CRJ10DJ750T	RES , CHIP	
R1579	CRJ10DJ750T	RES , CHIP	
R1580	CRJ10DJ750T	RES , CHIP	
R1582	CRJ10DF1002T	RES , CHIP 1%	
R1585	CRJ10DJ330T	RES , CHIP	
R1613	CRJ10DJ0R0T	RES , CHIP	
R1614	CRJ10DJ0R0T	RES , CHIP	
R1616	CRJ10DJ0R0T	RES , CHIP	
R1618	CRJ10DJ101T	RES , CHIP	
R1624	CRJ10DJ0R0T	RES , CHIP	
X1401	HOX27000E180S	CRYSTAL , CHIP(27MHZ,SMD)	
X1402	COX19660E330S	X-TAL, CHIP, 19.6608 MHz (33P)	

LOAD No.	PARTS No.	DESCRIPTION	SPECIATION
	K8AYG6260	COMPOUND , SILICONE	
	C2K86102	SOLDER , FLUX WIRE PB FREE(PIE 1.0)	
BK101	CMD1A569	BRACKET , PCB	
BK102	CMD1A569	BRACKET , PCB	
BK103	CMD1A569	BRACKET , PCB	
BK104	CMY1A297	HEAT SINK	
BN141	CJP15GB99ZY	WAFER	
BN142	CJP15GB99ZY	WAFER	
BN143	CJP05GB99ZY	WAFER ANGLE	
BN146	CWB1D00910058	WIRE ASS'Y (9PIN, 2.5mm,100mm,STRAIGHT,#22)	
CN144	CJP17GB116ZY	WAFER	
CN145	CJP17GB116ZY	WAFER	
C1586	CCEA0JKR3222E	CAP , ELECT	
C1587	CCEA0JKR3222E	CAP , ELECT	
C1588	CCEA0JKR3222E	CAP , ELECT	
	CRE1A073	SUPPORT , PCB 31	
	CRE1A074	SUPPORT , PCB 44	
	CRE1A075	SUPPORT , PCB 48	
	CUAT747AH	BOTTOM CHASSIS ASS'Y	
	CKF4A397ZK1	PANEL , REAR T747AH	
	CKL1A086	FOOT	
	CLT5W035ZU	TRANS , POWER , USA	ONLY AH VERSION
	CLT5W035ZE	TRANS , POWER , EUR	ONLY C VERSION
	CLZ9W003Z	FERRITE , RING	
	CLZ9Z070Z	FERRITE , CORE	
	CMD1A495	COVER , SCREW	
	CRE1A073	SUPPORT , PCB 31	
	CRE1A074	SUPPORT , PCB 44	
	CRE1A075	SUPPORT , PCB 48	
	CUA1A292	CHASSIS , BOTTOM	
	CWC4C4A13B120B10	CABLE , CARD(13P, 120MM, 1.25MM)	
	CWC4C4A15B080B10	CABLE , CARD (15P,1.25MM,80MM,B,10MM)	
	CWC4F4A17B150B10A	FFC CABLE ASS'Y (CANEC0800462801)	
	CWZPM5003TW91A	2P WIRE ASS'Y(100MM)	
RT01	CJJ8A006ZW	RECEPTACLE , AC(15A/250V,R-301,B21)	
TW91	CWZPM5003TW91	2P WIRE ASS'Y(100MM)	
F5701	KBA2C8000TLEY	LITTEL FUSE(USA)	ONLY AH VERSION
	KBA2C6300TLEY	LITTEL FUSE(EUR)	ONLY C VERSION
	CFNKDE1208PTV1	MOTOR , DC BRUSHLESS FAN(80X80X25mm)	
PCB7	CNVMB014MA0J8LS	MODULE , TUNER USA	ONLY AH VERSION
	CNVMB014MA1J8L	MODULE , TUNER EUR	ONLY C VERSION
		ACCESSORY	
	CPS1A840	PAD , LEFT	
	CPS1A841	PAD , RIGHT	
	CQXT747AH	INSTRUCTION MANUAL ASS'Y	
	CABR6PPB	BATTERY , AA 2 PCS IN PACK	
	CARTT747M	MULTI ROOM REMOCON ASS'Y(12KEY)	
	CARTT747U	REMOCON ASS'Y (43KEY)	
	CJA2A070Z	CORD , POWER(PLUG+SOCKET)UL	
	CJXT747A	MICROPHONE ASS'Y WITH FERRITE CORE	
	CLZ9Z071Z	FERRITE , CORE	
	CQE1A184Z	CARD, WARRANTY	
	CQX1A1410X	MANUAL , INSTRUCTION	
	CSA1A019Z	FM 1 POL ANT(UL)	
	CSA1A020Z	ANT , AM LOOP	
	CGR1A476B29	COVER , JACK	

SERVICE MANUAL

© NAD 2009

T747

AV Surround Sound Receiver

NAD ELECTRONICS INTERNATIONAL
TORONTO