

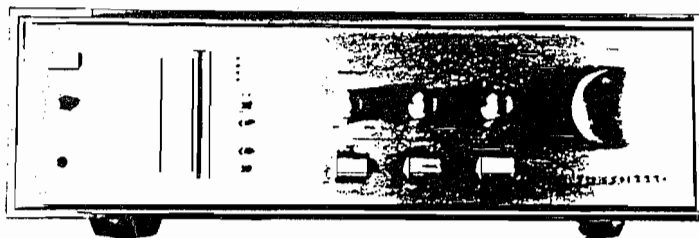

Service Manual

Nakamichi 1000p

Digital Audio Processor



CONTENTS

1. General	1-1
2. Removal Procedures	2-1
2.1. Top Cover Front/Rear Ass'y	2-1
2.2. Bottom Cover Front/Rear Ass'y	2-1
2.3. Front Panel Ass'y and Master Volume Knob Ass'y	2-2
2.4. Side Panel Left/Right	2-2
2.5. P.C.B. Ass'y	2-3
3. Adjustments	3-1
3.1. Parts Location for Electrical Adjustment	3-1
3.2. Electrical Adjustments	3-4
3.3. How to Use Extension Card	3-5
4. Mechanism Ass'y and Parts List	4-1
4.1. Synthesis	4-1
4.2. Front Panel Ass'y (A01)	4-3
4.3. Chassis Ass'y (A02)	4-5
4.4. Front Panel Sub Ass'y	4-8
4.5. Chassis Sub Ass'y (C01)	4-9
5. Main IC Block Diagrams	5-1
6. Block Diagram	6
7. Electrical Parts List	7-1
7.1. Power Switch P.C.B. Ass'y	7-1
7.2. Output Volume P.C.B. Ass'y	7-1
7.3. Input Volume P.C.B. Ass'y	7-1
7.4. Monitor Switch P.C.B. Ass'y	7-1
7.5. Headphone P.C.B. Ass'y	7-1
7.6. Analog Power Supply P.C.B. Ass'y	7-1
7.7. Digital Power Supply P.C.B. Ass'y	7-2
7.8. Display P.C.B. Ass'y	7-3
7.9. Function Switch P.C.B. Ass'y	7-3
7.10. CPU P.C.B. Ass'y	7-3
7.11. Mother P.C.B. Ass'y	7-4
7.12. DAC P.C.B. Ass'y	7-4
7.13. ADC P.C.B. Ass'y	7-6
7.14. DAIF-C P.C.B. Ass'y	7-9
8. Mounting Diagrams	8-1
8.1. Power Switch P.C.B. Ass'y	8-1
8.2. Output Volume P.C.B. Ass'y	8-1
8.3. Input Volume P.C.B. Ass'y	8-1
8.4. Monitor Switch P.C.B. Ass'y	8-1
8.5. Headphone P.C.B. Ass'y	8-1
8.6. Analog Power Supply P.C.B. Ass'y	8-1
8.7. Digital Power Supply P.C.B. Ass'y	8-2
8.8. Display P.C.B. Ass'y	8-2
8.9. Function Switch P.C.B. Ass'y	8-2
8.10. CPU P.C.B. Ass'y	8-3
8.11. Mother P.C.B. Ass'y	8-3
8.12. DAC P.C.B. Ass'y	8-3
8.13. ADC P.C.B. Ass'y	8-5
8.14. DAIF-C P.C.B. Ass'y	8-6
9. Schematic Diagrams	9-1
9.1. DAIF-C Section	9-1
9.2. DAC Section	9-2
9.3. ADC Section	9-3
9.4. Mother Board/CPU/Display Section	9-4
9.5. Power Supply Section	9-5
10. Wiring Diagram	10
11. Specifications	11

1.

1.
(1)

(2)

1.

1

1. GENERAL

1.1. CAUTIONS/WARNINGS

(1) Product Safety Notice

Parts marked with the symbol  in the schematic diagram have critical characteristics.

Use ONLY replacement parts recommended by the manufacturer.

It is recommended that the unit be operated from a suitable DC supply or batteries during initial check-out procedures.

(2) Leakage Current Check/Resistance Check

Before returning the unit to the customer, make sure you make either (1) a leakage current check or (2) a line to chassis resistance check. If the leakage current exceeds 0.5 milliamp, or if the resistance from the chassis to either side of the power cord is less than 240 K ohms, the unit is defective.

WARNING - DO NOT return the unit to the customer until the problem is located and corrected.

1.2. Destinations

USA - U.S.A.

CAN - Canada

EP - Europe

SWT - Switzerland

UK - United Kingdom

AUS - Australia

OTR - Other

JPN - Japan

1.3. Consumer Version/Professional Version

In the consumer version and professional version, some parts differ. Parts for consumer version are indicated as [N-1000P] in the parts list, and those for professional version are indicated as [N-1000P Pro.].

1.4. Package Ass'y and Accessory Ass'y

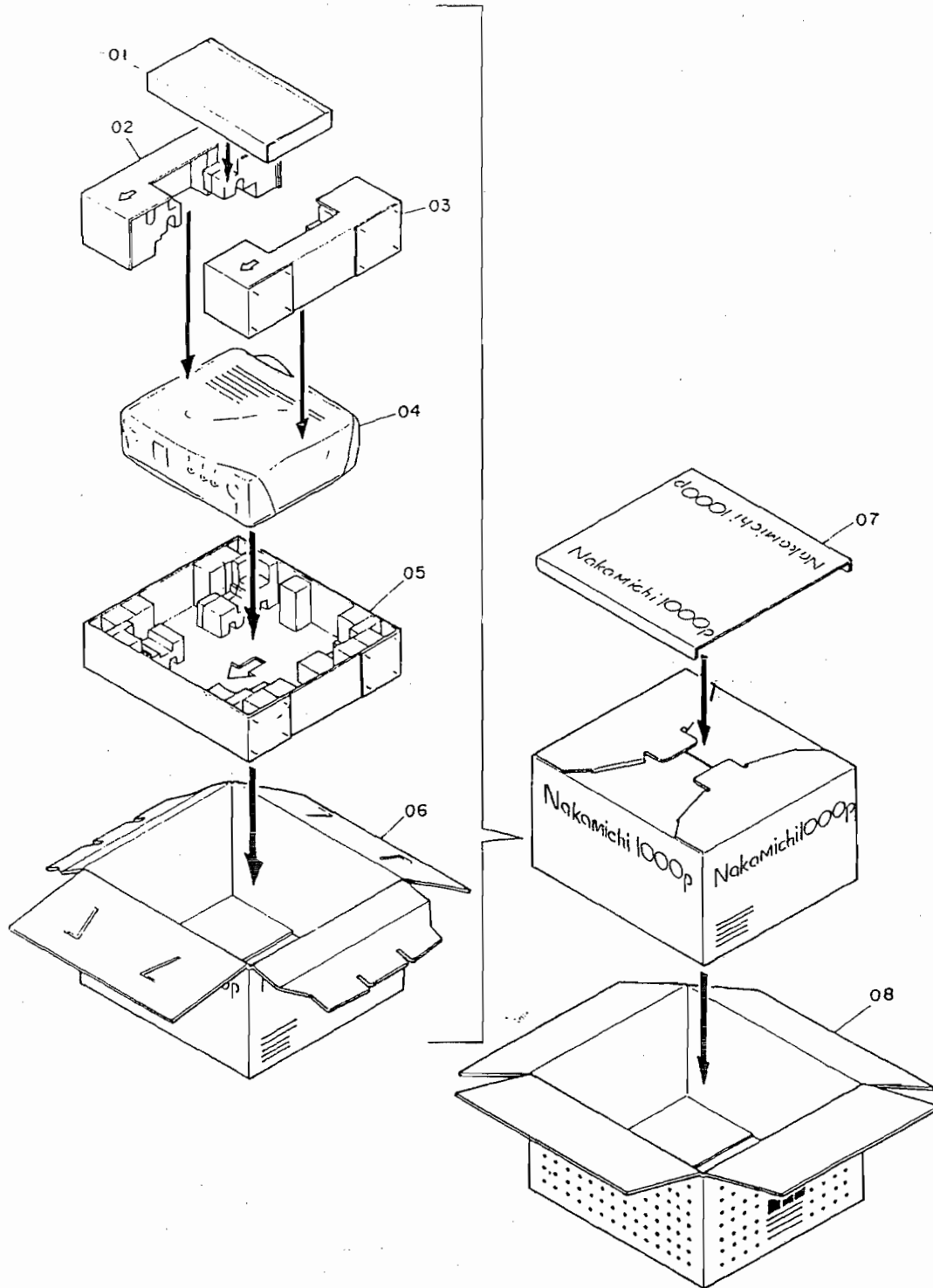

Fig. 1 Package Ass'y

<u>Ref. No.</u>	<u>Part No.</u>	<u>Description</u>	<u>Q'ty</u>
	-	Package Ass'y	
01	-	Accessory Ass'y	1
02	0F04246A	Packing Top Left	1
03	0F04247A	Packing Top Right	1
04	0F04241B	Soft Sheet	1
05	0F04245B	Packing Bottom	1
06	0F04236A	Inner Carton	1
07	0F04229A	Top Sheet	1
08	0F04233A	Outer Carton	1

<u>Ref. No.</u>	<u>Part No.</u>	<u>Description</u>	<u>Q'ty</u>
	-	Accessory Ass'y	1
	0F04239B	Accessory Box	1
	OD03092B	Poly Bag (For Accessory)	1
	OD04941A	Owner's Manual (English/German/French)	1
	OD04942A	Owner's Manual (Japanese)	1
	OD04936A	RCA Audio Cable (WHT)	2
	OD04997A	RCA Audio Cable (RED)	2
	OD04212A	Poly Bag (For Accessory) [N-1000P Pro.]	2
	OE03535A	M4x12 + Countersunk [N-1000P Pro.]	6
	OJ05954A	Pull-out Screw [N-1000P Pro.]	2
	HA05720A	Handle Ass'y [N-1000P Pro.]	2

2. REMOVAL PROCEDURES

2.1. Top Cover Front/Rear Ass'y

Refer to Fig. 2.1.

- (1) Loosen screws F01 (3 pcs.) and remove F02 (Top Cover Rear Ass'y).
- (2) Loosen screws F03 (2 pcs.), and slide F04 (Top Cover Front Ass'y) rearward to remove it.

2.2. Bottom Cover Front/Rear Ass'y

Refer to Fig. 2.2.

- (1) Loosen screws F01 (4 pcs.) and F02 (1 pce.), and remove F03 (Bottom Cover Front Ass'y).
- (2) Loosen screws F04 (4 pcs.) and F05 (1 pce.), and remove F06 (Bottom Cover Rear Ass'y).

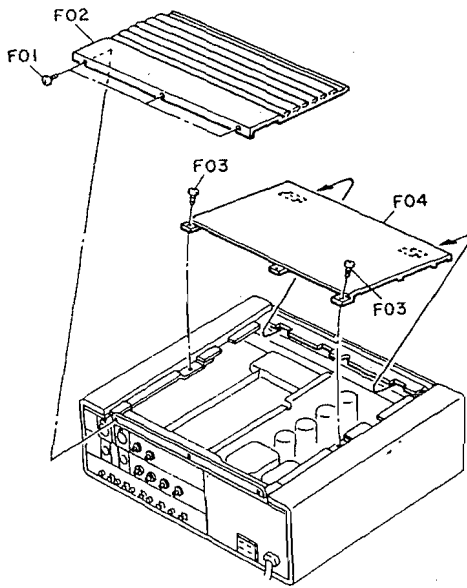

Fig. 2.1

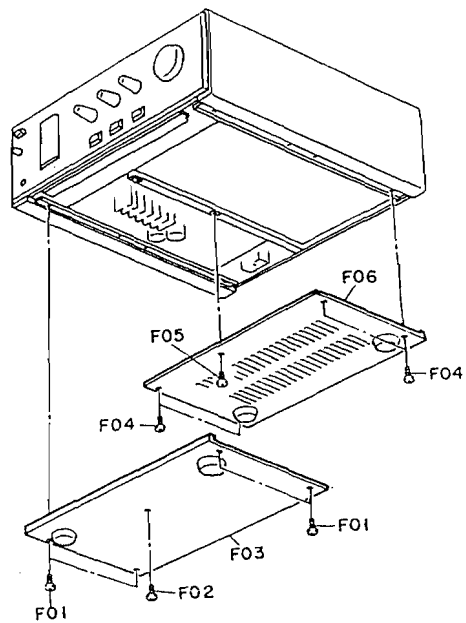

Fig. 2.2

2.3. Front Panel Ass'y and Master Volume Knob Ass'y

Refer to Fig. 2.3.

- (1) Remove the Top Cover Front/Rear Ass'y referring to item 2.1.
- (2) Remove the Bottom Cover Front Ass'y referring to item 2.2.
- (3) Remove screws F01 (6 pcs.) and remove F02 (Front Panel Ass'y).
- (4) Disconnect connectors of F02 (Front Panel Ass'y) from the main body.
- (5) Loosen a cup point screw F03 with a hex. wrench from the rear side of F02 (Front Panel Ass'y), and remove F04 (Master Volume Knob Ass'y).

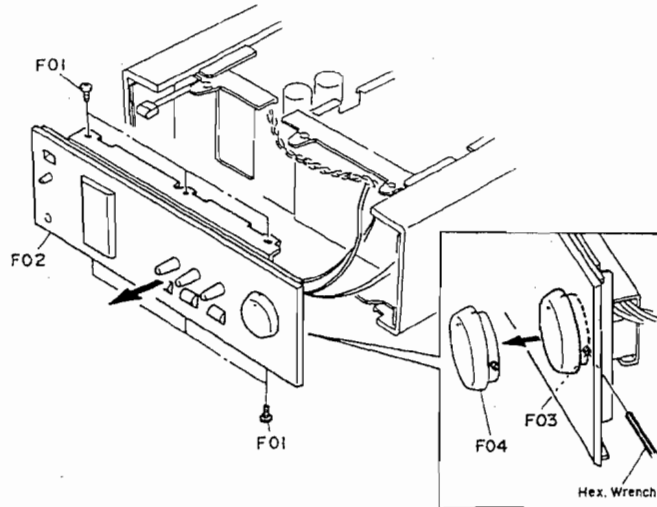

Fig. 2.3

2.4. Side Panel Left/Right

Refer to Fig. 2.4.

- (1) Remove the Top Cover Front/Rear Ass'y referring to item 2.1.
- (2) Remove the Bottom Cover Front/Rear Ass'y referring to item 2.2.
- (3) Loosen screws F01 (5 pcs.) and remove F02 (Side Panel Left).
- (4) Loosen screws F03 (5 pcs.) and remove F04 (Side Panel Right).

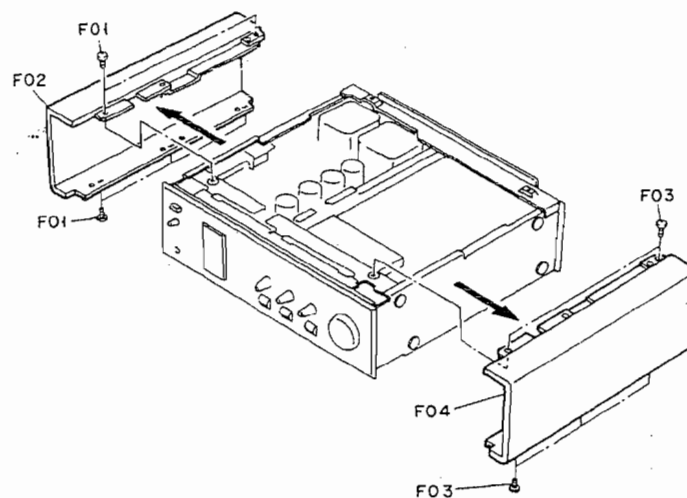

Fig. 2.4

2.5. P.C.B. Ass'y

Refer to Figs. 2.5.1 and 2.5.2.

- (1) Loosen screws F01 (2 pcs.) and screw them into holes A. See Fig. 2.7.1.
- (2) Hold the screw heads and pull out P.C.B. Ass'y along card rails. See Fig. 2.5.2.

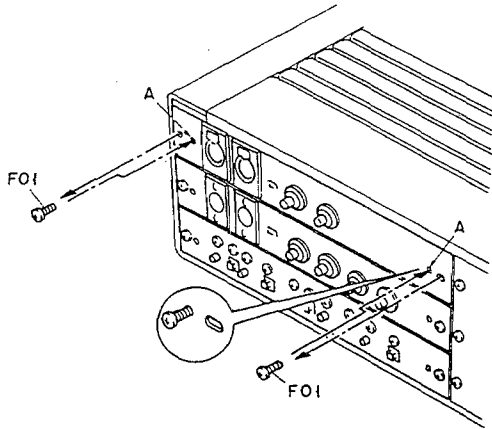

Fig. 2.5.1

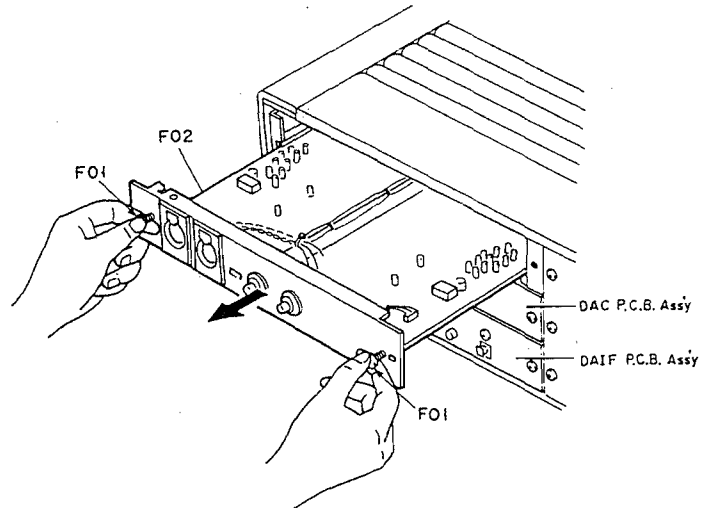

Fig. 2.5.2

3. ADJUSTMENTS

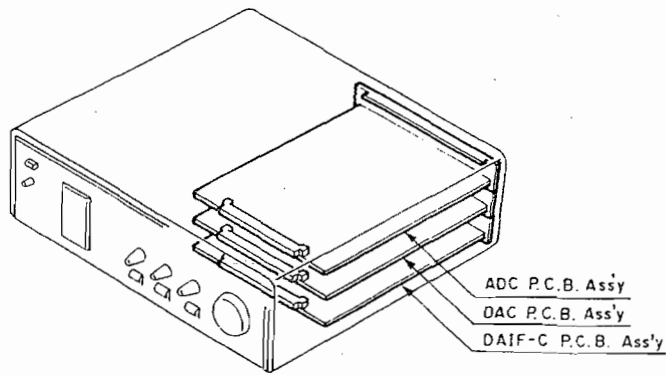

Fig. 3.1 Nakamichi 1000P (Front View)

3.1. Parts Location for Electrical Adjustment

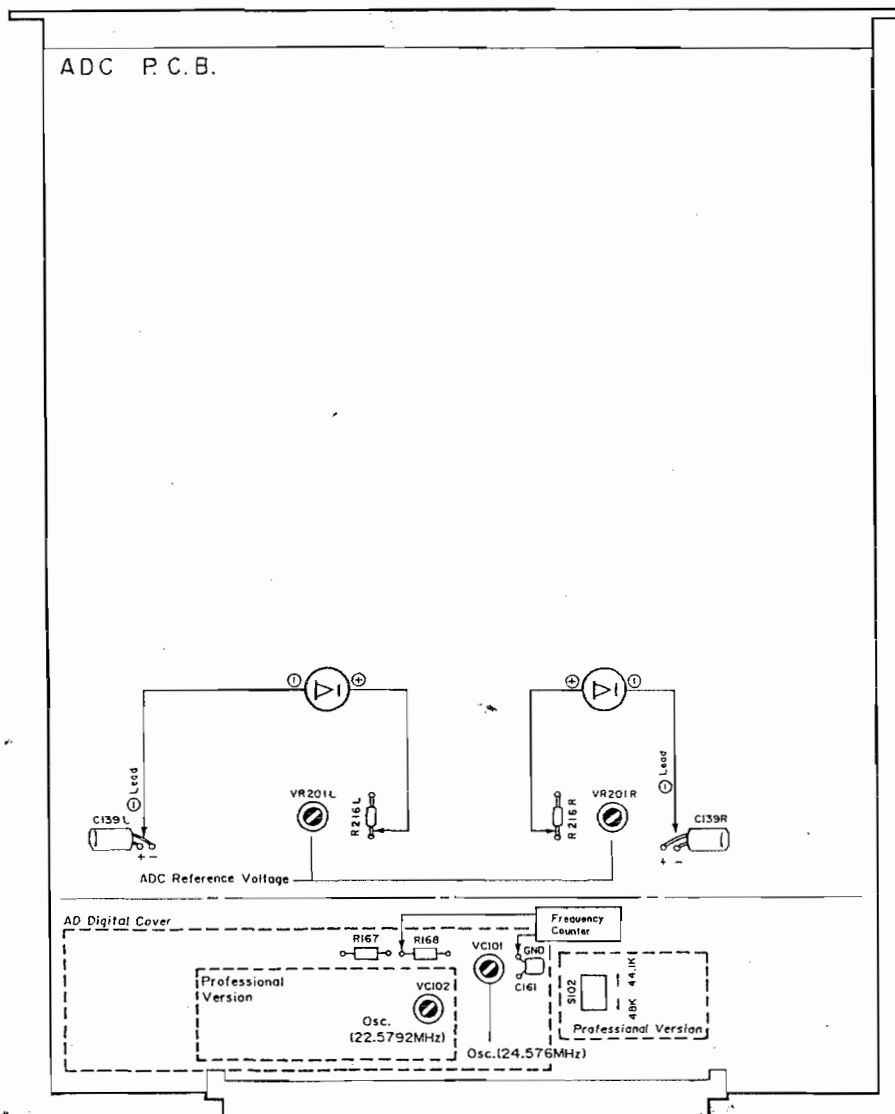

Fig. 3.2 ADC P.C.B. Ass'y

DAIF-C P.C.B.

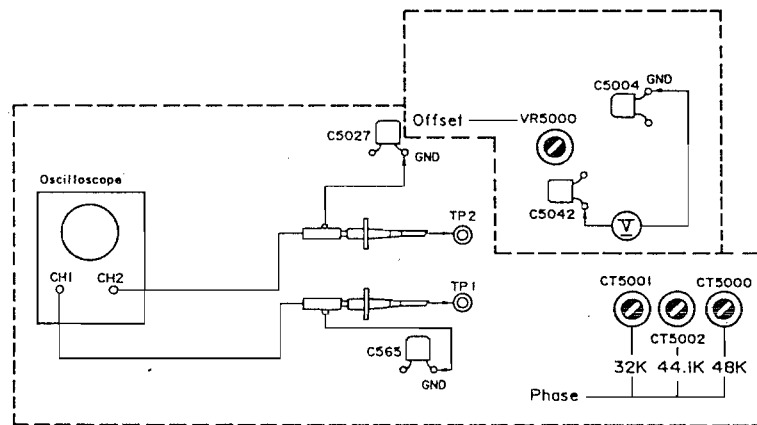

Fig. 3.3 DAIF-C P.C.B. Ass'y

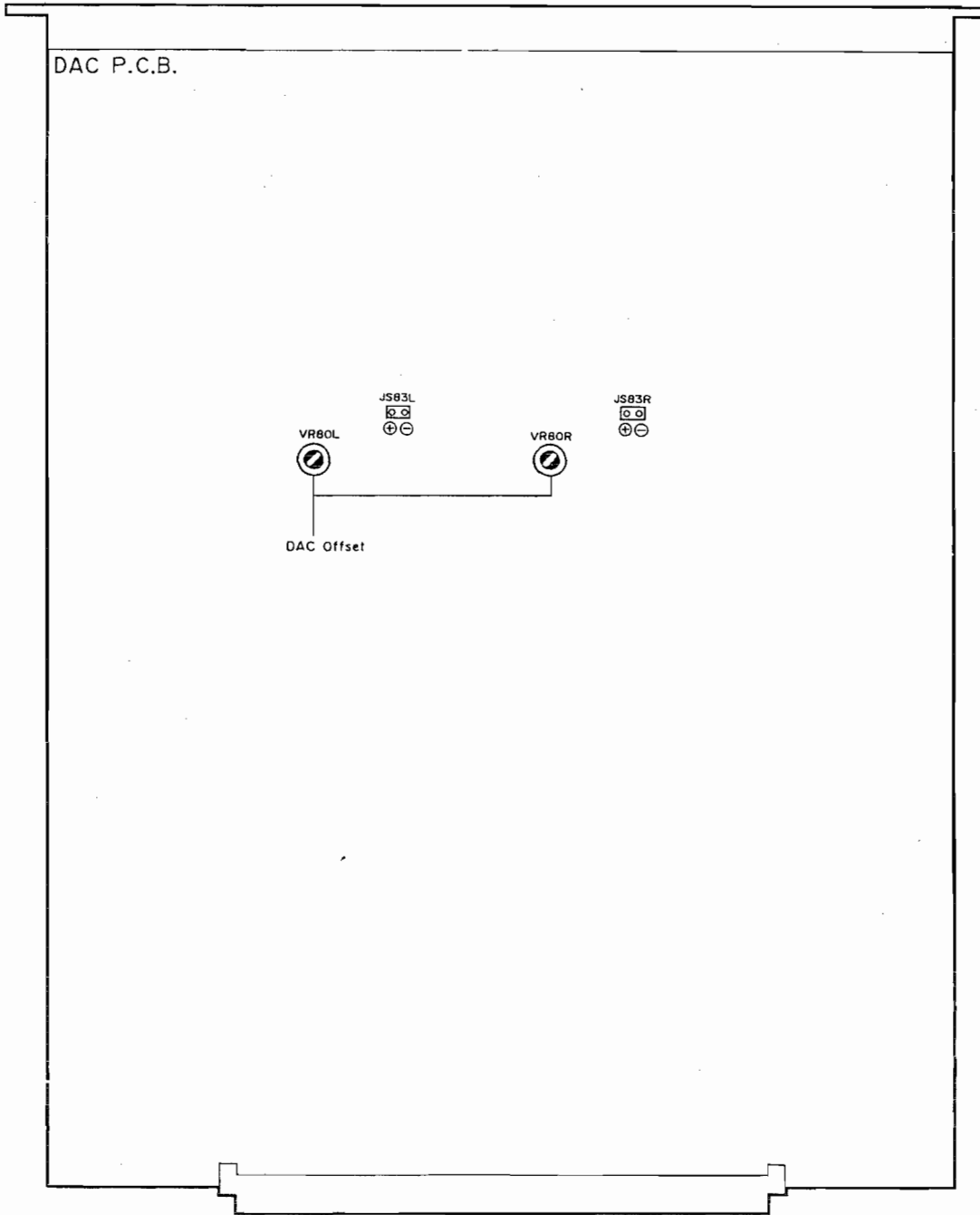
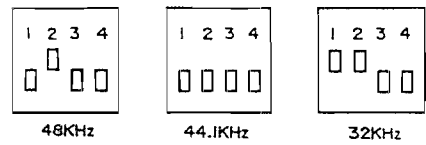
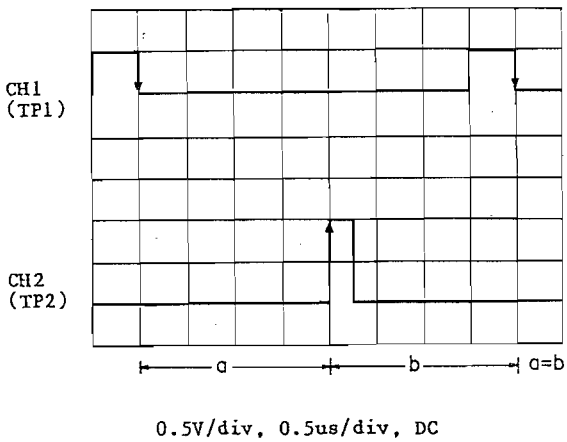

Fig. 3.4 DAC P.C.B. Ass'y

3.2. Electrical Adjustments

STEP	ITEM	SIGNAL SOURCE	OUTPUT CONNECTION	MODE	ADJUSTMENT	REMARKS
1	Preliminary Step					Turn on the power and leave the N-1000P for 2 to 3 minutes.
2	ADC Reference Voltage Adjustment (ADC P.C.B.)	None	Connect Digital (DC) Multi-meter as shown in Fig. 3.2. (ADC P.C.B.)		ADC P.C.B. VR201L VR201R	1. Adjust VR201L to obtain 4.5 V \pm 0.05 V. 2. Adjust VR201R to obtain 4.5 V \pm 0.05 V.
3	Oscillation Frequency Adjustment (ADC P.C.B.)	None	Frequency Counter between the intersection of R168 and R167, and GND (C161) on ADC P.C.B.		ADC P.C.B. VC101 VC102	Note: Before adjusting, remove the AD Digital Cover. Consumer Version: 1. Adjust VC101 to obtain 24.57600 MHz \pm 100 Hz. Professional Version: 1. Set the switch S102 on the ADC P.C.B. to 48 kHz. 2. Adjust VC101 to obtain 24.57600 MHz \pm 100 Hz. 3. Set the switch S102 on the ADC P.C.B. to 44.1 kHz. 4. Adjust VC102 to obtain 22.57920 MHz \pm 100 Hz.
4	Offset Adjustment (DAIF-C P.C.B.)	None	Digital (DC) Multi-meter between C5042 and GND (C5004) on DAIF-C P.C.B.		DAIF-C P.C.B. VR5000	1. Adjust VR5000 to obtain 3.50 V.
5	Phase Adjustment (DAIF-C P.C.B.)	Digital SG Output to "DAT1 Input Optical or Coaxial"	Oscilloscope CH1: TP1 and GND (C565) CH2: TP2 and GND (C5027) on DAIF-C P.C.B.	Monitor Selector - DAT1 Source Selector - Digital DAT1 Digital Input Selector (Rear Panel) - Optical or Coaxial	DAIF-C P.C.B. CT5000 (48K) CT5001 (32K) CT5002 (44.1K)	1. Set the Digital SG as follows: Fs: 48 kHz/32 kHz/44.1 kHz Offset: 0Z Optical or Coaxial Output: -18 dBm 2. Adjust the variable control of the oscilloscope so that one cycle ranges over 8 divisions on CH1 as shown left. 3. Adjust CT5000 for Fs48 kHz (CT5001 for Fs32 kHz and CT5002 for Fs44.1 kHz) so that the pulse on CH2 is positioned as shown left. 4. Set the offset of the digital SG to \pm 0.1% and make sure lock is securely made, i.e., sound is heard continuously without fail while listening with headphones. Example: Digital SG Fs setting (Fs Code)



STEP	ITEM	SIGNAL SOURCE	OUTPUT CONNECTION	MODE	ADJUSTMENT	REMARKS
6	DAC Offset Adjustment	Digital SG Output to "DAT1 Input Optical or Coaxial"	Distortion Meter to JS83L, JS83R via LPF (See below)	Monitor Selector - DAT1 Source Selector - Digital DAT1 Digital Input Selector (Rear Panel) - Optical or Coaxial	DAC P.C.B. VR80L VR80R	<ol style="list-style-type: none"> Set the Digital SG as follows: Fs: 48 kHz Frequency: 1 kHz Level: 0 dB Adjust VR80L (VR80R) to obtain minimum distortion.

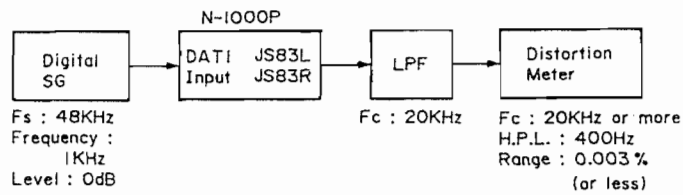

3.3. How to Use Extension Card

The ADC P.C.B. Ass'y, DAC P.C.B. Ass'y, and DAIF-C P.C.B. Ass'y can draw by connecting an Extension Card as shown below. This Extension Card can be used for the Nakamichi 1000 Digital Audio Processor as well.

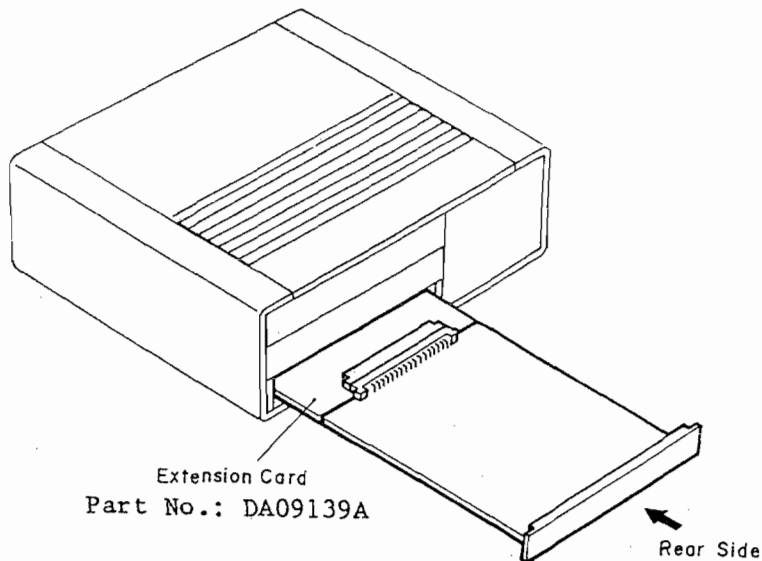

Fig. 3.5 How to Use Extension Card

4. MECHANISM ASS'Y AND PARTS LIST

4.1. Synthesis

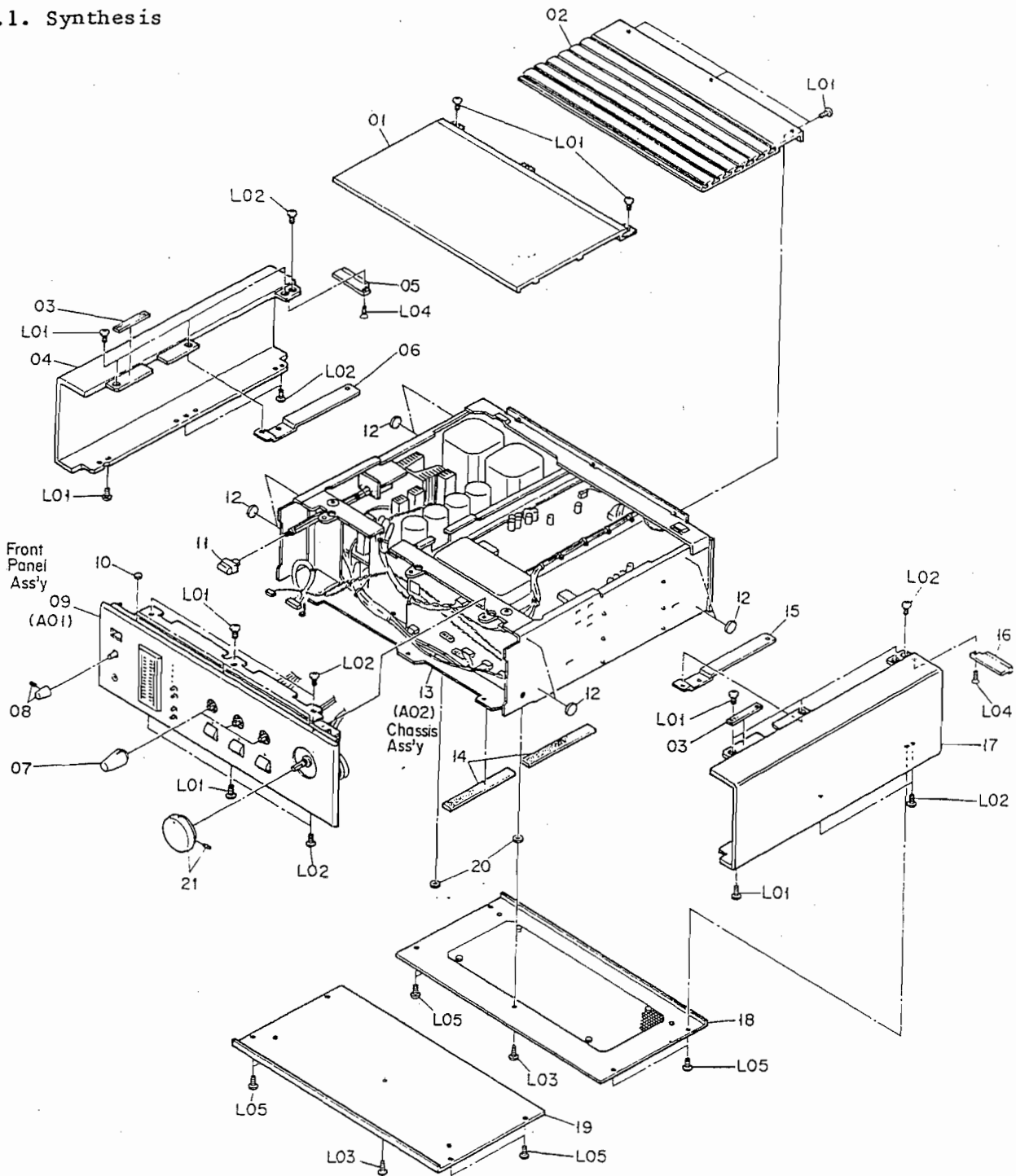

Fig. 4.1

<u>Ref. No.</u>	<u>Part No.</u>	<u>Description</u> Synthesis	<u>Qty</u>
01	HA05594A	Top Cover Front Ass'y	1
02	HA05595A	Top Cover Rear Ass'y	1
03	OJ05905A	Top Cover Cushion C	2
04	OH05452B	Side Panel Left [N-1000P]	1
	OH05567B	Side Panel Left [N-1000P Pro.]	1
05	OH05541B	Rear Plate Left	1
06	OJ05773C	Top Cover Holder L	1
07	HA05585A	Level Knob Ass'y	3
08	HA05708A	Phone Knob Ass'y	1
09	HA05569A	Front Panel Ass'y	1
10	OJ05938A	Top Spacer	3
11	HA05586A	Power Button Ass'y	1
12	OJ05909A	Side Spacer	8
13	-	Chassis Ass'y	1
14	OJ05907B	Bottom Cover Cushion	2
15	OJ05772C	Top Cover Holder R	1
16	OH05478B	Rear Plate Right	1
17	OH05453B	Side Panel Right [N-1000P]	1
	OH05566B	Side Panel Right [N-1000P Pro.]	1
18	HA05596A	Bottom Cover Rear Ass'y [N-1000P]	1
	HA05700A	Bottom Cover Rear Ass'y [N-1000P Pro.]	1
19	HA05617A	Bottom Cover Front Ass'y [N-1000P]	1
	HA05701A	Bottom Cover Front Ass'y [N-1000P Pro.]	1
20	OJ05965A	Bottom Spacer	2
21	HA05584A	Master Volume Knob Ass'y	1
L01	OE03536A	M3x5 + Binding Projected	
L02	OE03522A	M3x5 + Binding	
L03	OE03526A	BT3x6 + Binding	
L04	OE00076A	M2.6x4 + Countersunk	
L05	OE03551A	M3x8 + Binding Projected	
-	OE03538A	M4x6 + Countersunk [N-1000P Pro.]	

4.2. Front Panel Ass'y (A01)

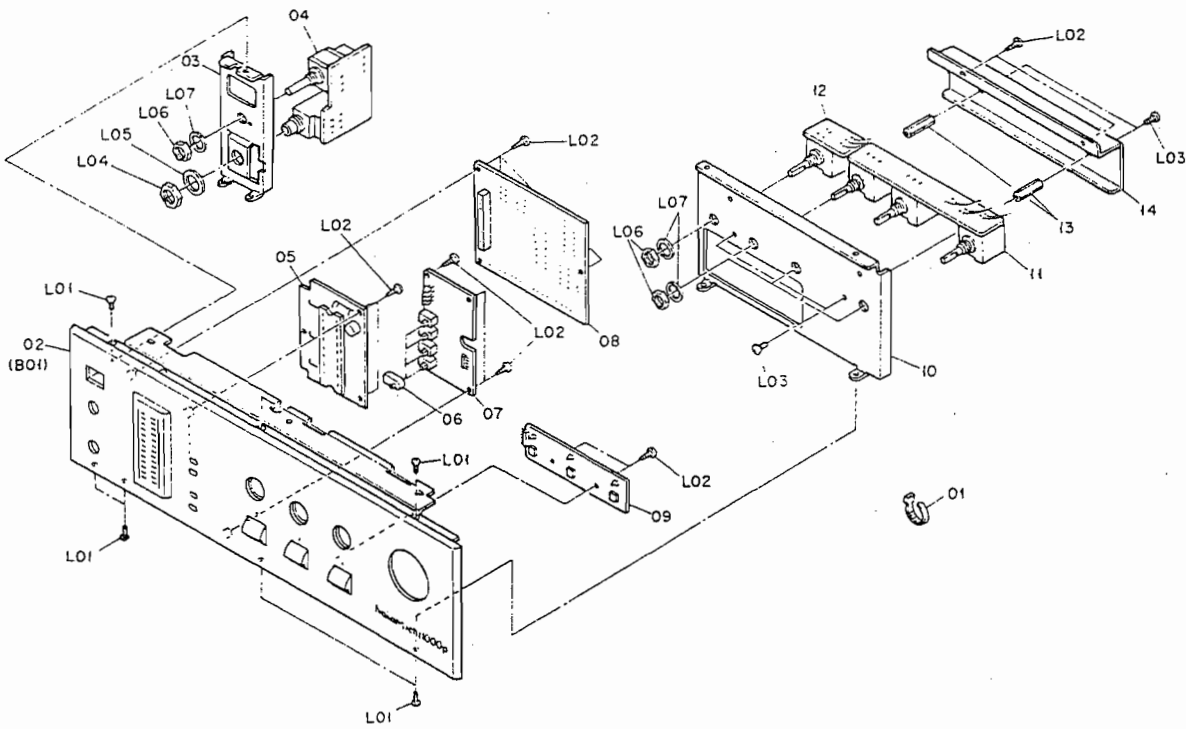

Fig. 4.2

<u>Ref. No.</u>	<u>Part No.</u>	<u>Description</u>	<u>Q'ty</u>
A01	HA05569A	Front Panel Ass'y	1
01	OB90019A	SK Binder	5
02	HA05620A	Front Panel Sub Ass'y	1
03	OJ05774A	Headphone Holder	1
04	BA07463B	Headphone P.C.B. Ass'y	1
05	BA07468B	Display P.C.B. Ass'y	1
06	HA05597A	Slide Switch Knob Ass'y	4
07	BA07467B	Function Switch P.C.B. Ass'y	1
08	BA07469B	CPU P.C.B. Ass'y	1
09	BA07466B	Monitor Switch P.C.B. Ass'y	1
10	OJ05775B	Volume Holder	1
11	BA07561B	Input Volume P.C.B. Ass'y	1
12	BA07560B	Output Volume P.C.B. Ass'y	1
13	OJ05848A	Stud 30mm	2
14	OJ05836A	Volume Shield Cover	1
L01	OE00184A	M2. 6x6 + Countersunk	
L02	OE00868A	BT3x8 + Binding	
L03	OE00896A	M3x6 + Binding	
L04	OE03524A	Nut Hex. M12	
L05	OE03525A	Washer M12	
L06	OE03375A	Nut Hex. M9	
L07	OE03376A	Washer M9	
-	OB83578B	9P H Connector Ass'y 370 (CN104)	1
-	OB83579B	10P H Connector Ass'y 350 (CN105)	1
-	OB83582B	8P H Connector Ass'y 80 (CN106)	1
-	OB83580B	12P H Connector Ass'y 330 (CN107)	1
-	OB83581B	11P H Connector Ass'y 390 (CN108)	1
-	OB83583A	4P H Connector Ass'y 60 (CN129) [1st Version]	1
-	OB83764A	5P H Connector Ass'y 60 (CN129) [2nd Version]	1

4.3. Chassis Ass'y (A02)

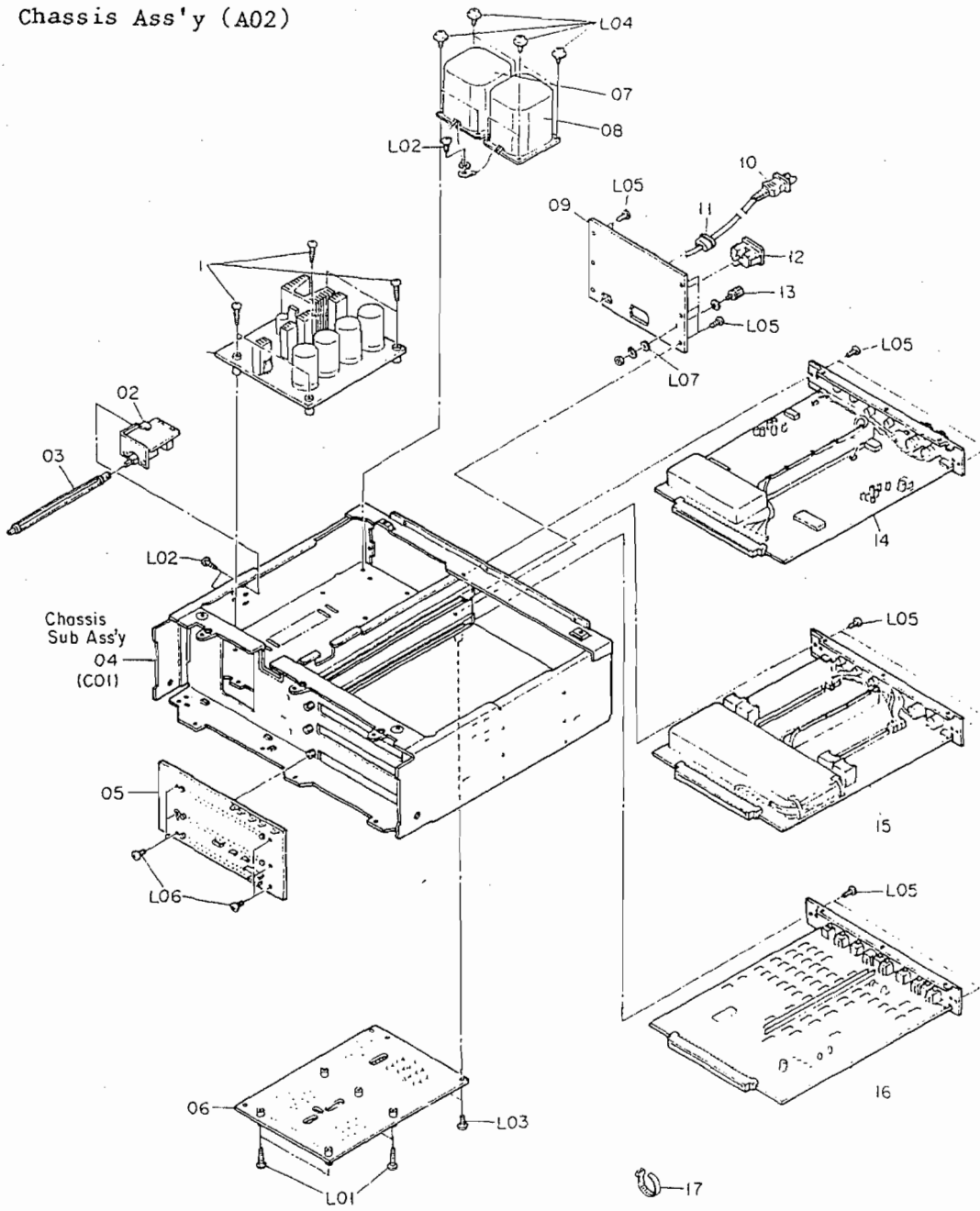
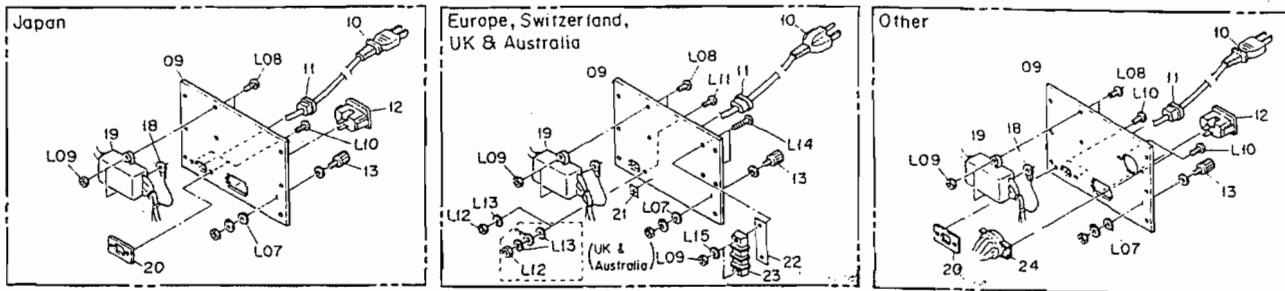

Fig. 4.3



<u>Ref. No.</u>	<u>Part No.</u>	<u>Description</u>	<u>Q'ty</u>
A02	-	Chassis Ass'y	1
01	BA07460B	Analog Power Supply P.C.B. Ass'y	1
02	BA07462B	Power Switch P.C.B. Ass'y (USA, CAN)	1
	BA07570B	Power Switch P.C.B. Ass'y (JPN)	1
	BA07575B	Power Switch P.C.B. Ass'y (UK, OTR, AUS, EP, SWT)	1
03	OJ05781A	Power Switch Joint	1
04	-	Chassis Sub Ass'y	1
05	BA07464B	Mother P.C.B. Ass'y	1
06	BA07461B	Digital Power Supply P.C.B. Ass'y (JPN, USA, CAN)	1
	BA07618B	Digital Power Supply P.C.B. Ass'y (UK, OTR, AUS, EP, SWT)	1
07	OB50148B	Power Transformer For Digital (USA, CAN)	1
	OB50149A	Power Transformer For Digital (JPN)	1
	OB50150A	Power Transformer For Digital (UK, AUS, EP, SWT)	1
	OB50151A	Power Transformer For Digital (OTR)	1
08	OB50144B	Power Transformer For Analog (USA, CAN)	1
	OB50145A	Power Transformer For Analog (JPN)	1
	OB50146A	Power Transformer For Analog (UK, AUS, EP, SWT)	1
	OB50147A	Power Transformer For Analog (OTR)	1
09	OH05494C	Rear Panel UL (USA, CAN)	1
	OH05522D	Rear Panel (OTR)	1
	OH05544D	Rear Panel (JPN)	1
	OH05546D	Rear Panel (EP, SWT)	1
	OH05556D	Rear Panel SA (UK, AUS)	1
10	OB80124A	Power Cord (EP)	1
	OB80132B	Power Cord (SWT)	1
	OB80085A	Power Cord (OFC) (JPN, OTR)	1
	OB80131A	Power Cord (OFC) (USA, CAN)	1
	OB80133B	Power Cord (AUS)	1
	OB80134B	Power Cord (UK)	1
11	OB90157A	Cord Bushing (SR-6N-4) (UK, AUS, EP, SWT, USA, CAN)	1
	OB90186A	Cord Bushing (SR-33-1) (JPN, OTR)	1
12	OB81597A	AC Outlet 2P (USA, CAN)	1
	OB84102A	AC Outlet 2P (AC-T06SB10) (JPN, OTR)	1
13	OB81685A	Earth Terminal T5435	1
14	HA05754A	ADC P.C.B. Ass'y [N-1000P]	1
	HA05756A	ADC P.C.B. Ass'y [N-1000P Pro.] (UK, OTR, AUS, EP, SWT)	1
	HA05755A	ADC P.C.B. Ass'y [N-1000P Pro.] (JPN, USA, CAN)	1
15	HA05757A	DAC P.C.B. Ass'y [N-1000P]	1
	HA05759A	DAC P.C.B. Ass'y [N-1000P Pro.] (UK, OTR, AUS, EP, SWT)	1
	HA05758A	DAC P.C.B. Ass'y [N-1000P Pro.] (JPN, USA, CAN)	1
16	HA05568A	DAIF-C P.C.B. Ass'y [N-1000P]	1
	HA05718A	DAIF-C P.C.B. Ass'y [N-1000P Pro.]	1
17	OB90019A	Insu-Lock	60
18	OB83607A	GND Ass'y (JPN, OTR)	1
19	BA07697A	Noise Filter P.C.B. Ass'y (UK, AUS, EP, SWT, JPN, OTR)	1
20	OJ05939A	Bushing Plate (JPN, OTR)	1
21	OM03700A	Earth Mark Label (AUS, SWT)	1
22	OJ05694A	Insulator A (UK, AUS, EP, SWT)	1
23	OB81937A	Terminal (UK, AUS, EP, SWT)	1
24	OB70049A	Voltage Selector (OTR)	1
L01	OE03136A	BT3x16 + Binding	
L02	OE00857A	BT3x6 + Binding	
L03	OE00992A	M3x4 + Binding	
L04	OE03032A	BT4x8 + Pan Washer Faced (Black Chromate)	

Ref. No.	Part No.	Description	Q'ty
L05	OE03522A	M3x5 + Binding	
L06	OE00896A	M3x6 + Binding	
L07	OE03537A	Washer 6mm Toothed Lock	
L08	OE03517A	M3x5 + Binding (UK, AUS, EP, SWT, JPN, OTR)	
L09	OE00718A	Nut Hex. M3 (UK, AUS, EP, SWT, JPN, OTR)	
L10	OE03519A	M3x6 + Binding (JPN, OTR)	
L11	OE03547A	M4x6 + Binding (UK, AUS, EP, SWT)	
L12	OE00506A	Nut Hex. M4 (UK, AUS, EP, SWT)	
L13	OE00078A	Washer 4mm Toothed Lock (UK, AUS, EP, SWT)	
L14	OE03546A	M3x14 + Binding (UK, AUS, EP, SWT)	
L15	OE00172A	Washer 3mm Toothed Lock (UK, AUS, EP, SWT)	
-	OJ05940A	Insulator Sheet	1
-	OB83602B	3P/4P H Connecotr Ass'y (CN117)	1
-	OB83603A	3P/4P H Connecotr Ass'y (CN118)	1
-	OB83592B	4P H Connecotr Ass'y (CN119)	1
-	OB83593B	6P H Connector Ass'y (CN120)	1
-	OB83594B	4P H Connector Ass'y (CN121)	1
-	OB83595B	2P H Connector Ass'y (CN122)	1
-	OB83600B	4P H Connector Ass'y (CN123)	1
-	OB83601B	8P H Connector Ass'y (CN124)	1
-	OB83597B	2P H Connector Ass'y (CN125)	1
-	OB83598B	2P H Connector Ass'y (CN126)	1
-	OB83596B	3P H Connector Ass'y (CN130)	1
-	OB83604A	4P H Connector Ass'y (CN131)	1
-	OB83605B	3P H Connector Ass'y (CN132)	1
-	OB83656B	3P H Connector Ass'y (CN401)	1
-	OB83655B	3P H Connector Ass'y (CN403)	1
-	OJ05942A	AC Outlet Spacer (USA, CAN)	1

4.4. Front Panel Sub Ass'y (B01)

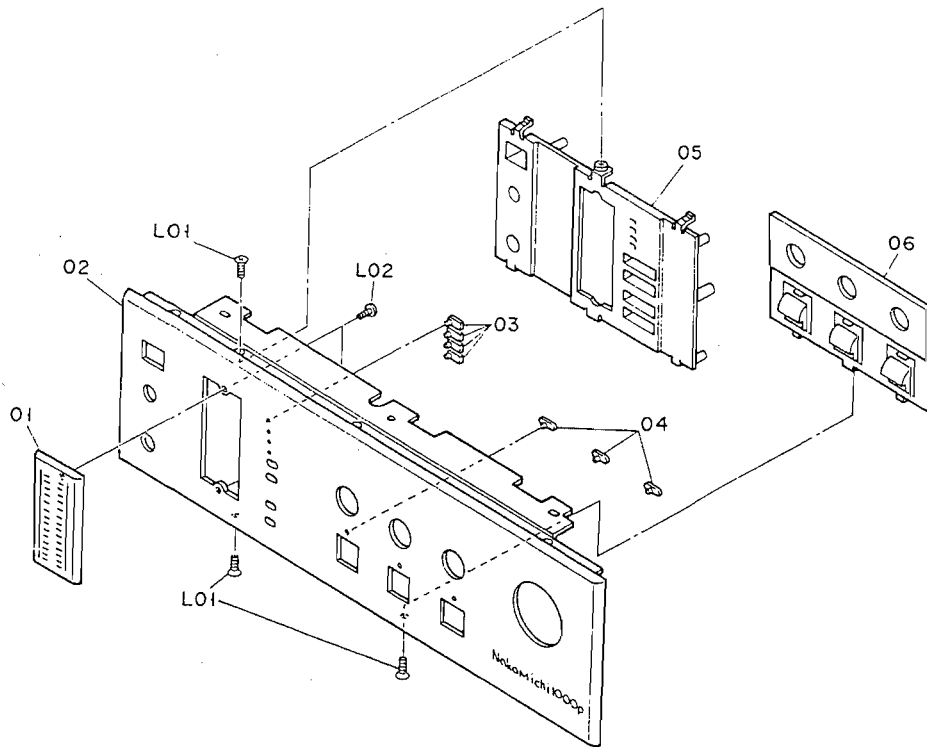

Fig. 4.4

Ref. No.	Part No.	Description	Q'ty
B01	HA05620A	Front Panel Sub Ass'y	1
01	HA05605A	Meter Panel Ass'y	1
02	OH05451D	Front Panel	1
03	OH05488A	LED Lens B	4
04	OH05487A	LED Lens A	3
05	OJ05761A	Meter Escutcheon	1
06	HA05606A	Selector Escutcheon Ass'y	1
L01	OE03473A	BT2.6x6 + Countersunk	
L02	OE00866A	M2.6x4 + Binding	

4.5. Chassis Sub Ass'y (C01)

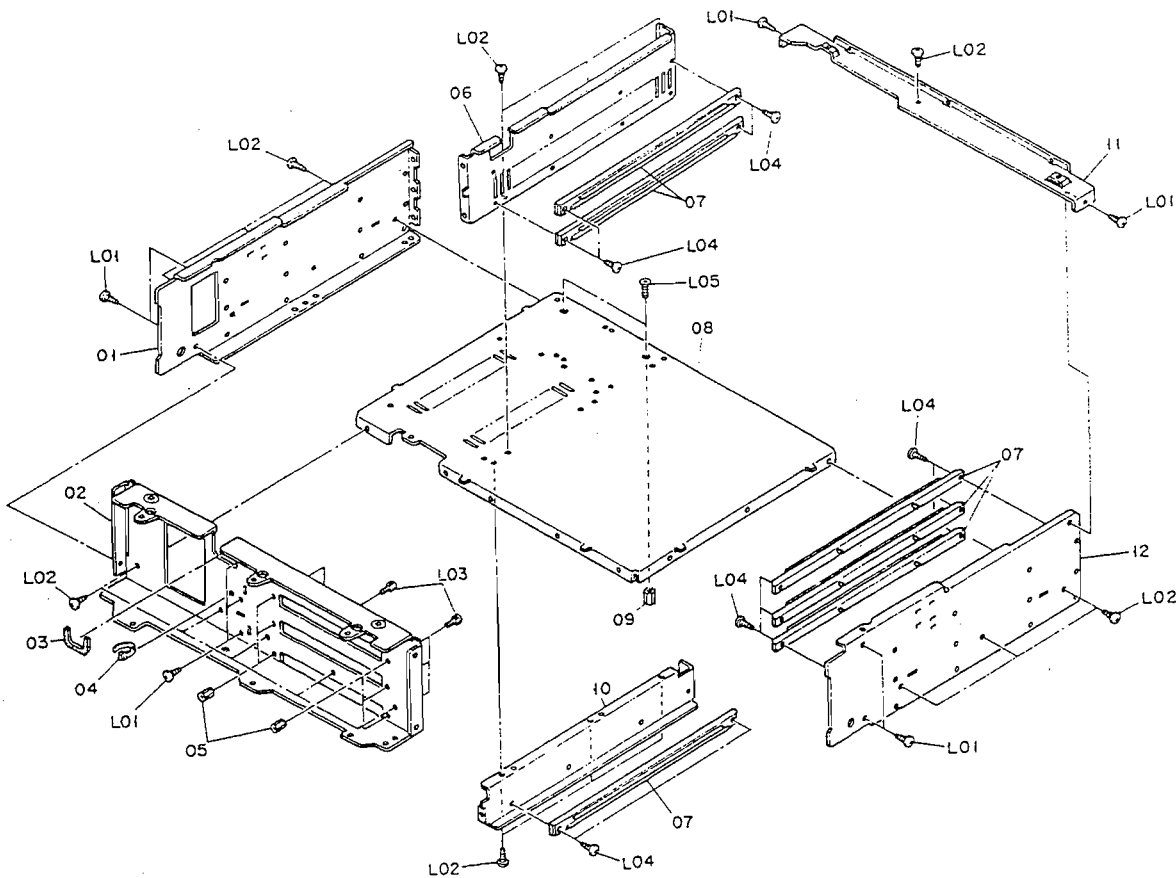

Fig. 4.5

Ref. No.	Part No.	Description	Q'ty
C01	-	Chassis Sub Ass'y	1
01	OJ05766A	Side Chassis Left	1
02	OJ05764C	Front Chassis	1
03	OB90417A	Free Bushing 82mm (KG-016L)	1
04	OB90398A	Insu-Lock (PLP-1.5I)	1
05	OJ05793A	Stud 8.5mm	6
06	OJ05768C	Center Chassis Upper	1
07	OJ05776A	Card Rail	6
08	OJ05832B	Main Chassis	1
09	OJ05851A	Stud 7.5mm	2
10	OJ05769D	Center Chassis Lower	1
11	OJ05770A	Rear Angle	1
12	OJ05767C	Side Chassis Right	1
L01	OE03515A	BT3x8 + Binding (Copper)	
L02	OE03366A	BT3x8 + Binding	
L03	OE00612A	M3x6 + Pan (2A)	
L04	OE00857A	BT3x6 + Binding	
L05	OE00505A	M3x6 + Countersunk	

5. MAIN IC BLOCK DIAGRAMS

(1) CXD1146Q DAIF (Digital Audio Interface)
U524 on DAIF-C P.C.B. Ass'y

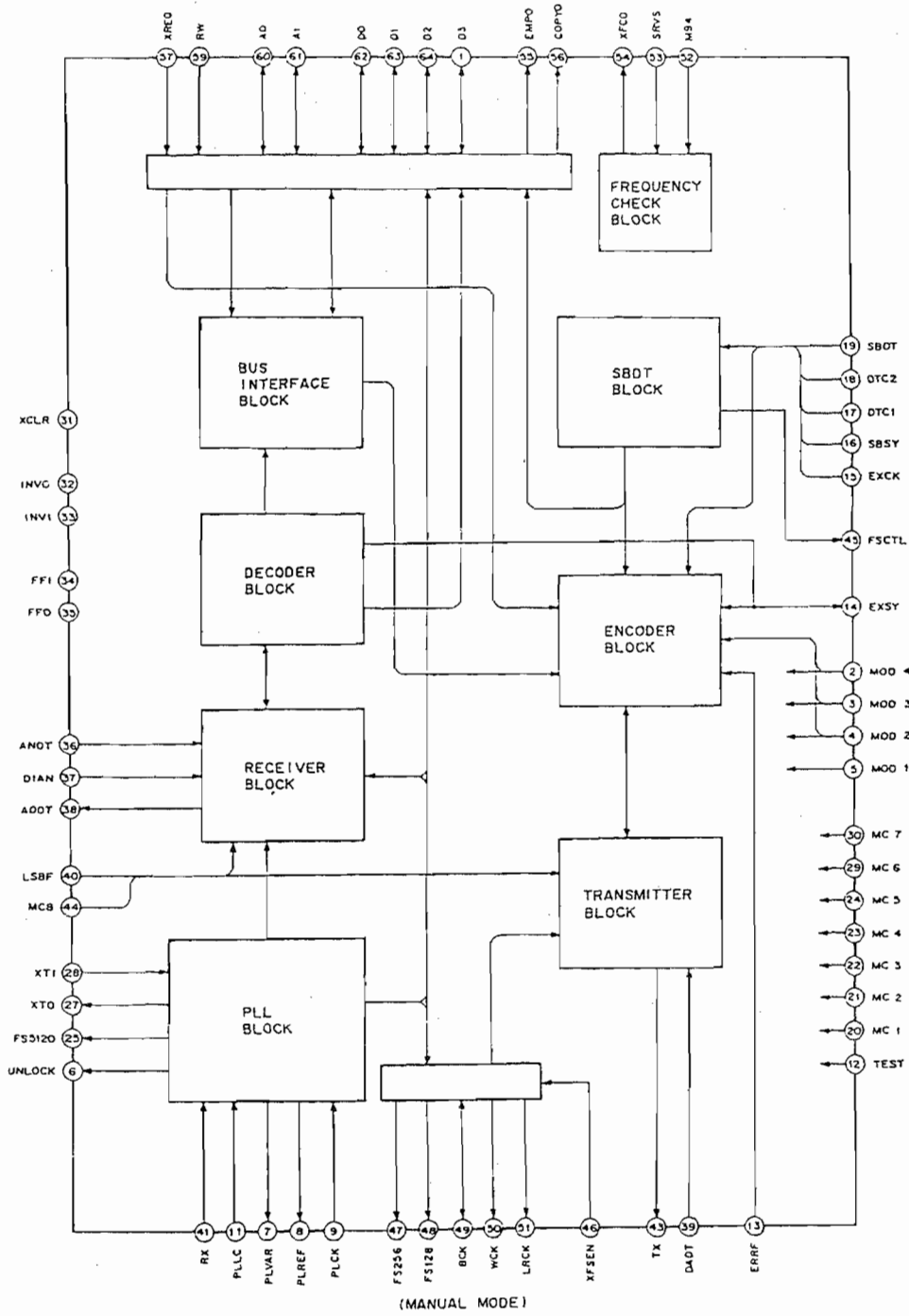

Fig. 5.1

(2) CXD1211P Digital Audio Data Transmitter
 U514 on DAIF-C P.C.B. Ass'y

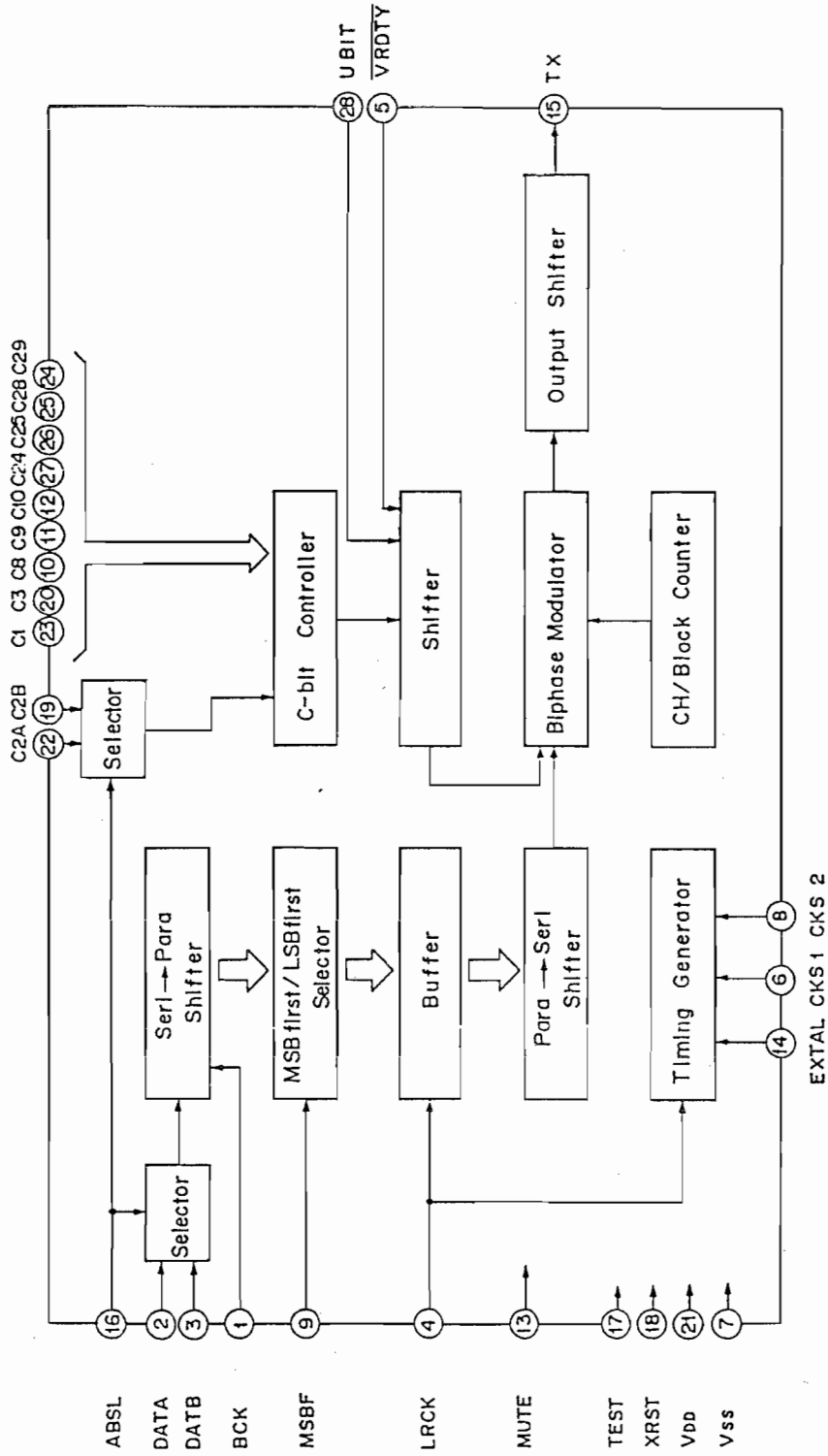

Fig. 5.2

(3) CX23065 Phase Compator (PLL)
U531 on DAIF-C P.C.B. Ass'y

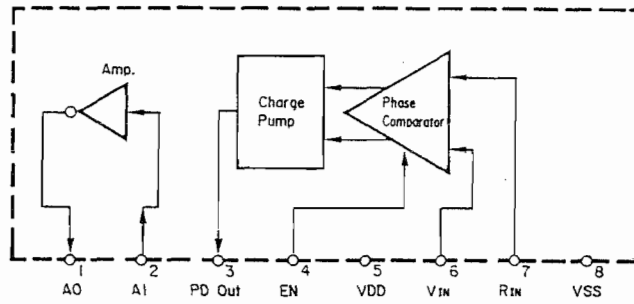

Fig. 5.3

(4) SM5803 8-Times Oversampling Digital Filter
U801 on DAC P.C.B. Ass'y

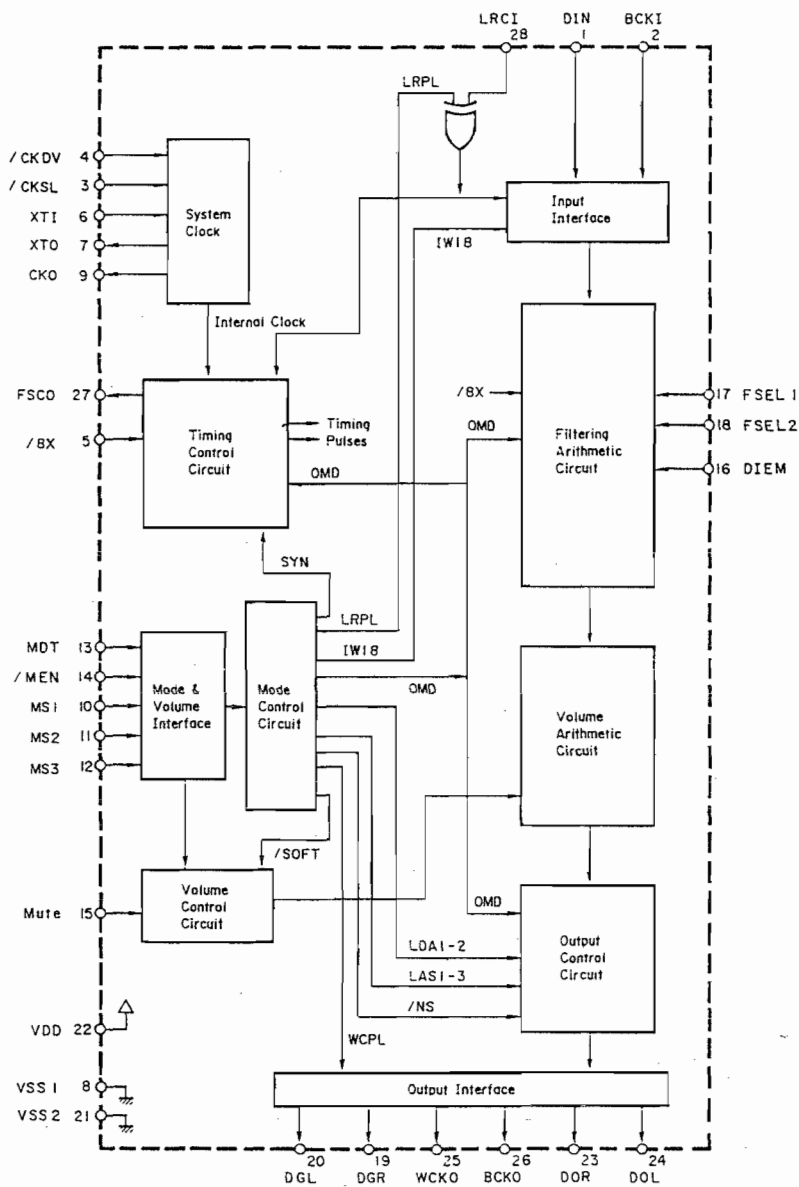

Fig. 5.4

(5) TDA1541S1 D/A Converter
 U880L and U880R on DAC P.C.B. Ass'y

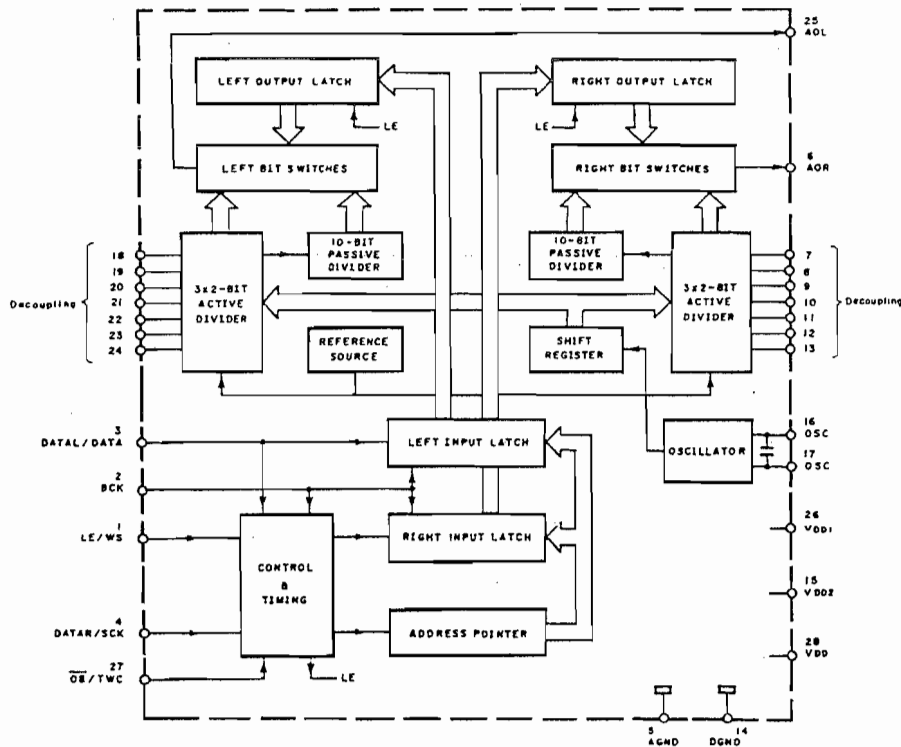

Fig. 5.5

(6) AK9201 A/D Converter
 U105L and U105R on ADC P.C.B. Ass'y

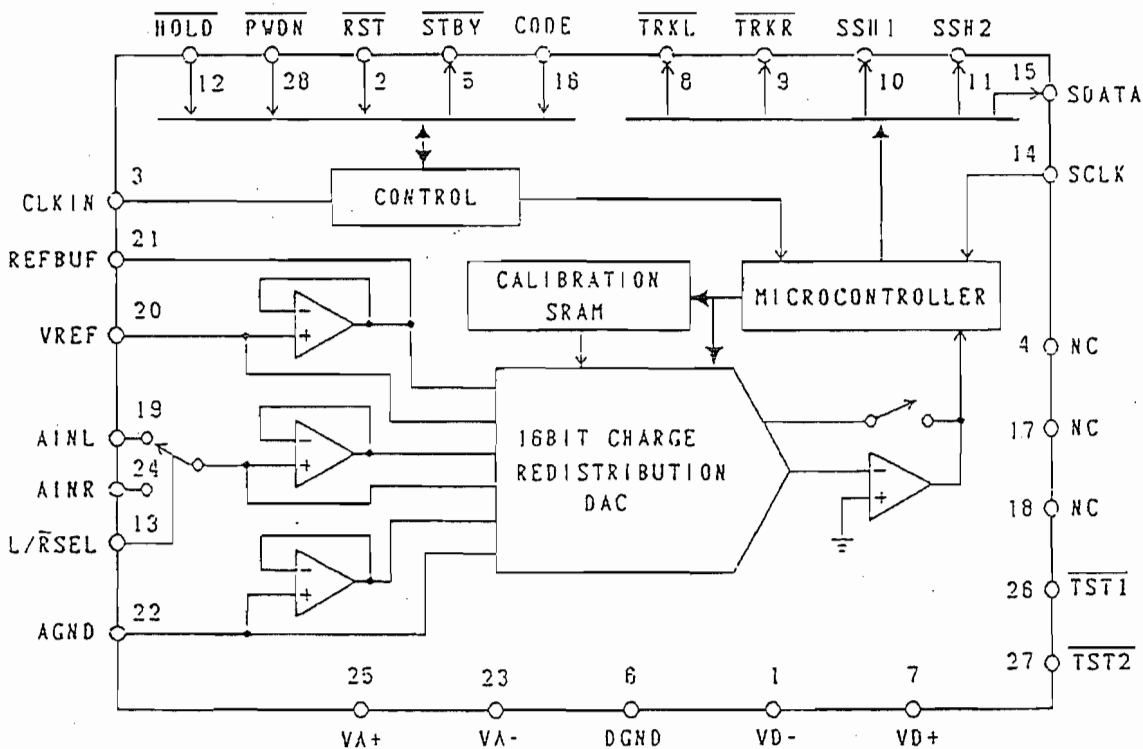

Fig. 5.6

(7) SM5805 Digital Filter (for Digital Audio Recording and Playback)
U113 on ADC P.C.B. Ass'y

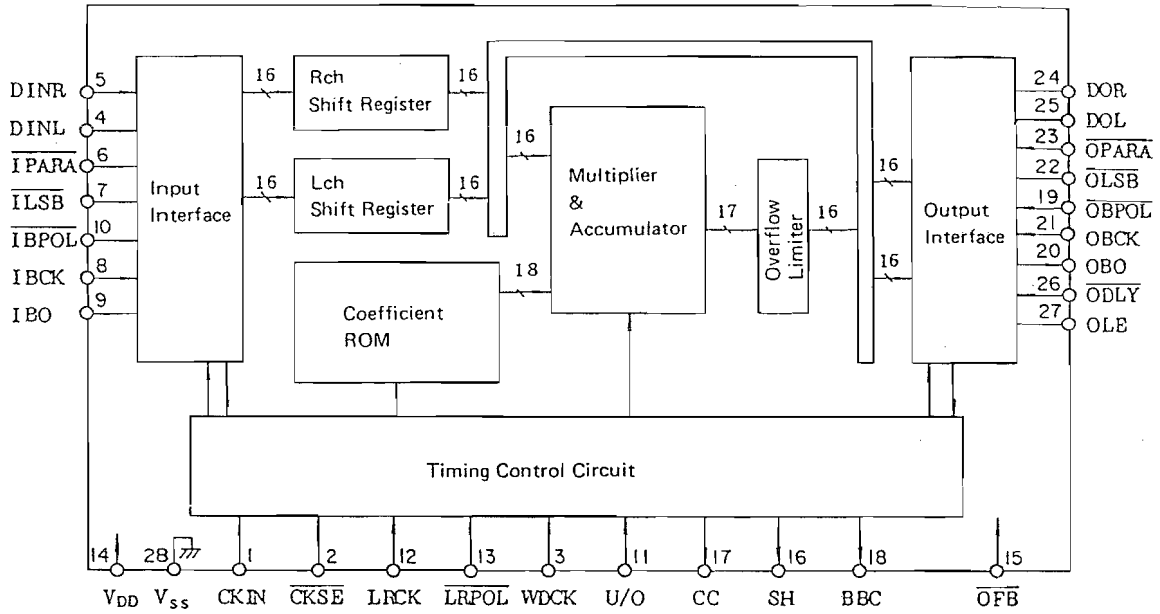

Fig. 5.7

(8) LS624 Voltage-Controlled Oscillator
U532 on DAIF-C P.C.B. Ass'y

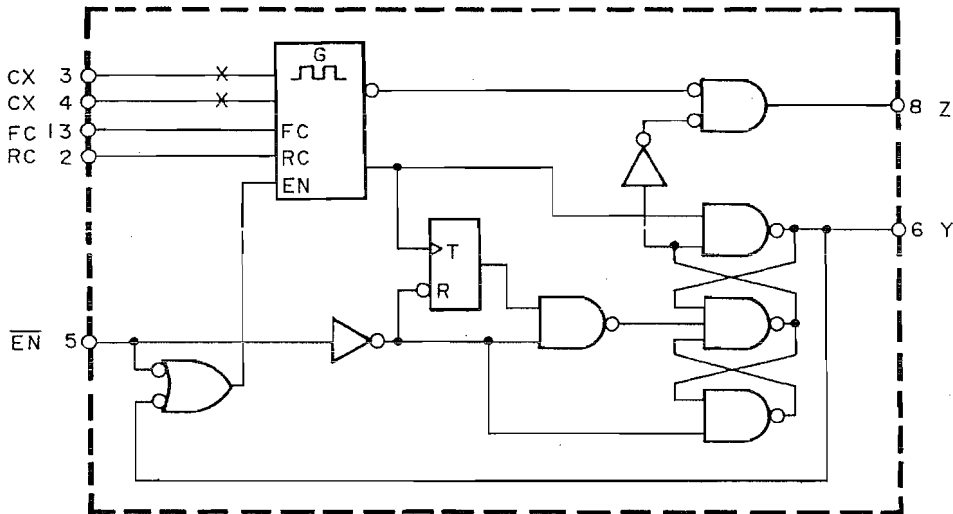

Fig. 5.8

6. BLOCK DIAGRAM

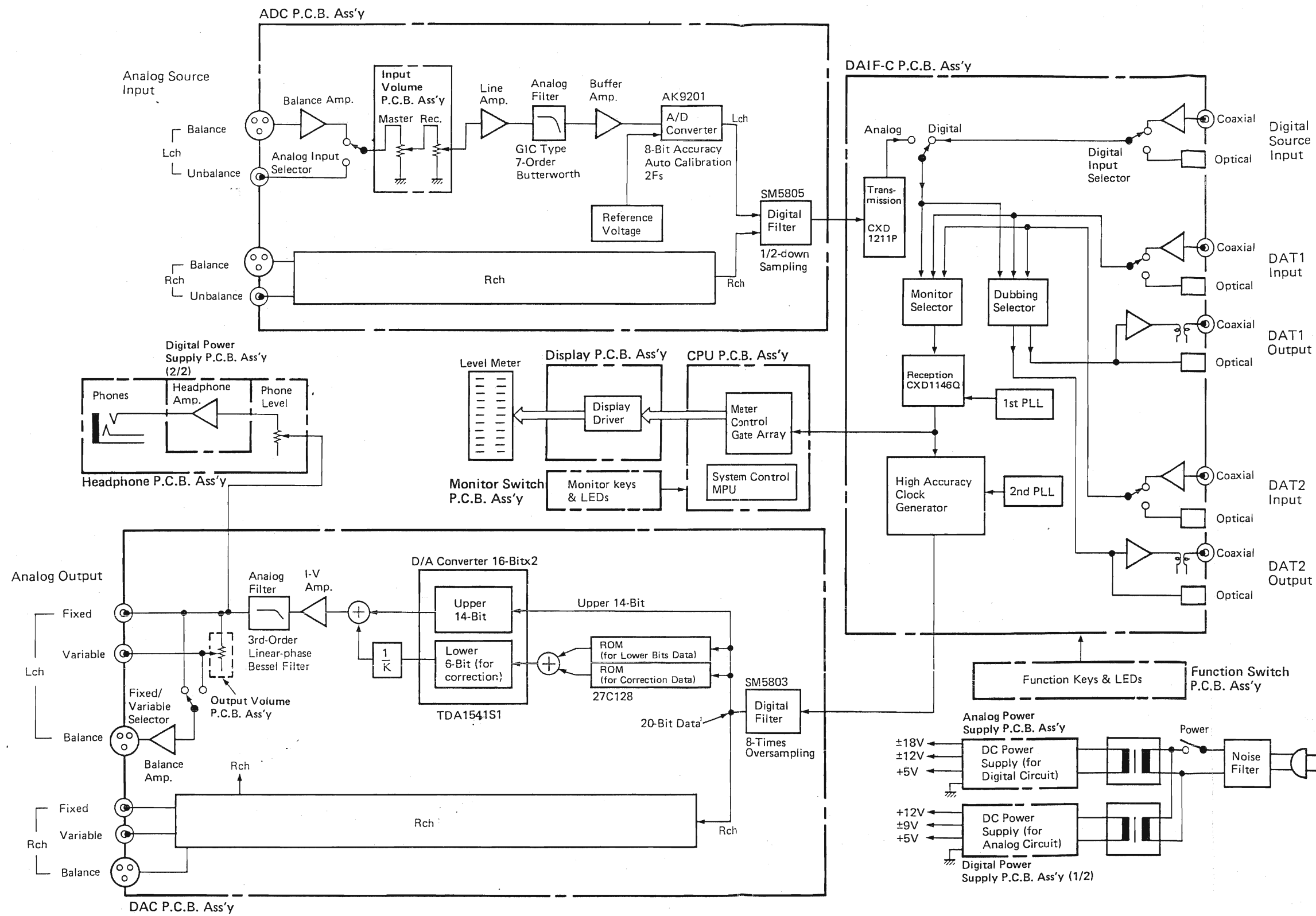

Fig. 6

7. ELECTRICAL PARTS LIST

Abbreviation for part name:

TR - Transistor, SiD - Silicon Diode, ZD - Zener Diode, Varicap - Variable Capacitance Diode
 RK - Carbon Resistor, RM - Metal Film Resistor, RF - Fail Safe Type Resistor, RC - Cement Resistor
 CE - Electrolytic Capacitor, CML - Mylar Capacitor, CC - Ceramic Capacitor, CPP - PP Capacitor,
 CMM - Metalized Mylar Capacitor, CSP - Polystyrene Capacitor, C - Mica Capacitor
 CT - Tantalum Capacitor

7.1. Power Switch P.C.B. Ass'y

Ref. No.	Part No.	Description
	BA07462B	Power Switch P.C.B. Ass'y (USA, CAN)
	BA07570B	Power Switch P.C.B. Ass'y (JPN)
	BA07575B	Power Switch P.C.B. Ass'y (UK, OTR, AUS, EP, SWT)
M401	OB60665B	Power Switch P.C.B.
	OB08342A	Spark Killer ECQ-JC187C (USA, CAN)
M401	OB08363A	Spark Killer (JPN)
M401	OB90255A	Spark Killer (UK, OTR, AUS, EP, SWT)
S401	OB71006A	Power Switch SDLIPB
	OE00868A	3x8 + Binding (1)
	OE00896A	3x6 + Binding (2)
	OJ05833A	Power Switch Holder (1)
	OJ05941A	Power Insulator (1)

7.2. Output Volume P.C.B. Ass'y

Ref. No.	Part No.	Description
	BA07560B	Output Volume P.C.B. Ass'y
	OB60690B	Output Volume P.C.B.
VR902	OB30106A	VR 10K(A)x2
CN113	OB83588B	4P-H Connector Ass'y 300
CN115	OB83590B	4P-H Connector Ass'y 300

7.3. Input Volume P.C.B. Ass'y

Ref. No.	Part No.	Description
	BA07561B	Input Volume P.C.B. Ass'y
	OB60668B	Input Volume P.C.B.
VR903, 904	OB30105A	VR 50K(A)
VR905	OB30107A	VR 50K(A)x2
CN109	OB83584B	4P-H Connector Ass'y 280
CN111	OB83586B	4P-H Connector Ass'y 280

7.4. Monitor Switch P.C.B. Ass'y

Ref. No.	Part No.	Description
	BA07466B	Monitor Switch P.C.B. Ass'y
	OB60669B	Monitor Switch P.C.B.
ED701, 702	OB12641A	LED Umber
ED703	OB12641A	LED Umber
R709, 710	OB09661A	RK 220 1/6W J
R711	OB09661A	RK 220 1/6W J
S702, 703	OB70043A	Tact Switch
S704	OB70043A	Tact Switch
CN106	OB81042A	8P S-Post White

7.5. Headphone P.C.B. Ass'y

Ref. No.	Part No.	Description
	BA07463B	Headphone P.C.B. Ass'y
	OB60666B	Headphone P.C.B.
Q901	OB10060A	TR DTA143ES
Q902	OB10078A	TR 2SC2240 (GR)
D901	OB06398A	SiD 1SS176
VR901	OB30103A	VR 50K(A)x2
R901, 902	OB09701A	RK 10K 1/6W J
RY901	OB90361A	Relay DC12V AG2323
PJ901	OB84011A	Phone Jack
CN123	OB84031A	4P S-Post Red
CN124	OB84032A	8P S-Post Red
CN125	OB81036A	2P S-Post White
CN126	OB84033A	2P S-Post Red

7.6. Analog Power Supply P.C.B. Ass'y

Ref. No.	Part No.	Description
	BA07460B	Analog Power Supply P.C.B. Ass'y
	OB60663C	Analog Power Supply P.C.B.
U401	OB11569A	IC STK90050
Q401	OB10014A	TR 2SA992
Q402	OB06322A	TR 2SC2002 (K, L)
Q403	OB10206A	TR 2SC2167
Q404	OB10275A	TR 2SC1845
Q405	OB06142A	TR 2SC2240 (BL)
Q406	OB10275A	TR 2SC1845
Q407	OB10050A	TR 2SA970 (BL)
Q408	OB10014A	TR 2SA992
Q409	OB06372A	TR 2SA953 (K, L)
Q410	OB10207A	TR 2SA957
Q411	OB10014A	TR 2SA992
Q412	OB06322A	TR 2SC2002 (K, L)
Q413	OB10206A	TR 2SC2167
Q414	OB10275A	TR 2SC1845
Q415	OB06142A	TR 2SC2240 (BL)
Q416	OB10275A	TR 2SC1845
Q417	OB10050A	TR 2SA970 (BL)
Q418	OB10014A	TR 2SA992
Q419	OB06372A	TR 2SA953 (K, L)
Q420	OB10207A	TR 2SA957
Q421	OB10050A	TR 2SA970 (BL)
Q422	OB06322A	TR 2SC2002 (K, L)
Q423	OB10206A	TR 2SC2167
Q424	OB06142A	TR 2SC2240 (BL)
Q425	OB10050A	TR 2SA970 (BL)
Q426	OB06142A	TR 2SC2240 (BL)
Q427	OB06372A	TR 2SA953 (K, L)
Q428	OB10207A	TR 2SA957
Q429, 430	OB10078A	TR 2SC2240 (GR)
Q431	OB06303A	TR 2SB772 (P, Q)
IP401, 402	OB11335A	ICP-N15
IP403, 404	OB11335A	ICP-N15
IP405, 406	OB11335A	ICP-N15
ZD401	OB12147A	ZD 5.1V RD5.1JSB2
ZD402	OB12650A	ZD 1.8V LTZ-MR15
ZD403	OB12147A	ZD 5.1V RD5.1JSB2
ZD404	OB12650A	ZD 1.8V LTZ-MR15
ZD405	OB12147A	ZD 5.1V RD5.1JSB2
ZD406	OB12650A	ZD 1.8V LTZ-MR15
ZD407	OB12147A	ZD 5.1V RD5.1JSB2
ZD408	OB12650A	ZD 1.8V LTZ-MR15
ZD409, 410	OB12177A	ZD 13V RD13JSB2
D401, 402	OB12102A	SiD 10DF2
D403, 404	OB12102A	SiD 10DF2
D405, 406	OB12634A	Varistor

Ref. No.	Part No.	Description
D407, 408	OB12102A	SiD 10DF2
D409, 410	OB12102A	SiD 10DF2
D411, 412	OB12634A	Varistor
D413, 414	OB12634A	Varistor
D415	OB12362A	SiD S5566B
R401	OB25325A	RM 22.6K 1/4W F
R402, 403	OB25132A	RM 221 1/4W F
R404	OB25164A	RM 475 1/4W F
R405	OB25171A	RM 562 1/4W F
R406	OB25252A	RM 3.92K 1/4W F
R407	OB25298A	RM 11.8K 1/4W F
R408	OB25268A	RM 5.76K 1/4W F
R409	OB25325A	RM 22.6K 1/4W F
R410, 411	OB25132A	RM 221 1/4W F
R412	OB25164A	RM 475 1/4W F
R413	OB25171A	RM 562 1/4W F
R414	OB25252A	RM 3.92K 1/4W F
R415	OB25268A	RM 5.76K 1/4W F
R416	OB25298A	RM 11.8K 1/4W F
R417	OB25325A	RM 22.6K 1/4W F
R418, 419	OB25132A	RM 221 1/4W F
R420	OB25164A	RM 475 1/4W F
R421	OB25171A	RM 562 1/4W F
R422	OB25252A	RM 3.92K 1/4W F
R423	OB25298A	RM 11.8K 1/4W F
R424	OB25268A	RM 5.76K 1/4W F
R425	OB25325A	RM 22.6K 1/4W F
R426, 427	OB25132A	RM 221 1/4W F
R428	OB25164A	RM 475 1/4W F
R429	OB25171A	RM 562 1/4W F
R430	OB25252A	RM 3.92K 1/4W F
R431	OB25268A	RM 5.76K 1/4W F
R432	OB25298A	RM 11.8K 1/4W F
R433, 434	OB25145A	RM 301 1/4W F
R435, 436	OB25171A	RM 562 1/4W F
R437, 438	OB09719A	RK 56K 1/6W J
R439	OB09725A	RK 100K 1/6W J
R440	OB09695A	RK 5.6K 1/6W J
R441	OB25341A	RM 33.2K 1/4W F
R442	OB09661A	RK 220 1/6W J
R443, 444	OB25228A	RM 2.21K 1/4W F
R445, 446	OB25228A	RM 2.21K 1/4W F
R447	OB09677A	RK 1.0K 1/6W J
C401	OB40520A	CE 6800u 35V
C402	OB41176A	CML 0.22u 63V J
C403	OB09834A	CPP 2200P 100V J
C404	OB40377A	CE 100u 16V (LN)
C406	OB40640A	CE 220u 25V (LN)
C407	OB41176A	CML 0.22u 63V J
C408	OB40520A	CE 6800u 35V
C409	OB41176A	CML 0.22u 63V J
C410	OB09834A	CPP 2200P 100V J
C411	OB40377A	CE 100u 16V (LN)
C413	OB40640A	CE 220u 25V (LN)
C414	OB41176A	CML 0.22u 63V J
C415	OB40520A	CE 6800u 35V
C416	OB41176A	CML 0.22u 63V J
C417	OB09834A	CPP 2200P 100V J
C418	OB40377A	CE 100u 16V (LN)
C420	OB40640A	CE 220u 25V (LN)
C421	OB41176A	CML 0.22u 63V J
C422	OB40520A	CE 6800u 35V
C423	OB41176A	CML 0.22u 63V J
C424	OB09834A	CPP 2200P 100V J
C425	OB40377A	CE 100u 16V (LN)
C427	OB40640A	CE 220u 25V (LN)
C428	OB41176A	CML 0.22u 63V J
C429	OB40377A	CE 100u 16V (LN)
C430	OB40581A	CE 470u 16V (LN)
C431	OB41176A	CML 0.22u 63V J
C432	OB40377A	CE 100u 16V (LN)
C433	OB40581A	CE 470u 16V (LN)
C434	OB41176A	CML 0.22u 63V J
C436	OB40427A	CE 1000u 16V (LN)
C437	OB01836A	CE 470u 10V
C438	OB41823A	CML 0.01u 50V J
C439	OB40618A	CE 10u 25V
CN117, 118	OB84045A	3P T-Post Gold
CN130	OB84044A	3P T-Post Gold
CN131	OB81233A	4P T-Post Red
CN132	OB81227A	3P T-Post White

Ref. No.	Part No.	Description
CN401	OB84044A	3P T-Post Gold
CN403	OB84044A	3P T-Post Gold
	OB90402A	Heat Sink (MT-50-BS-AN-0) (4)
	OE00857A	BT3x6 + Binding Chromate
	OE03319A	M3x8 + Binding (5)
	OJ05811A	Heat Sink (AJ-50-BS-AN-0) (1)
	OJ05960A	PCB Bush (5)
	OJ05961A	PCB Collar (5)

7.7. Digital Power Supply P.C.B. Ass'y

Ref. No.	Part No.	Description
	BA07461B	Digital Power Supply P.C.B. Ass'y (USA, CAN, JPN)
	BA07618B	Digital Power Supply P.C.B. Ass'y (UK, OTR, AUS, EP, SWT)

- Headphone Amp. -

Ref. No.	Part No.	Description
Q320L, R	OB06365A	FET 2SK240 (GR)
Q321L, R	OB10050A	TR 2SA970 (BL)
Q322L, R	OB10050A	TR 2SA970 (BL)
Q323L, R	OB06142A	TR 2SC2240 (BL)
Q324L, R	OB06142A	TR 2SC2240 (BL)
Q325L, R	OB10050A	TR 2SA970 (BL)
D320L, R	OB06398A	SiD 1SS176
D321L, R	OB12635A	Varistor SV03YS
R340L, R	OB22791A	RM 100 1/4W F
R341L, R	OB22793A	RM 332K 1/4W F
R342L, R	OB25485A	RM 1.00K 1/4W F
R343L, R	OB25485A	RM 1.00K 1/4W F
R344L, R	OB22792A	RM 200 1/4W F
R345L, R	OB22795A	RM 6.19K 1/4W F
R346L, R	OB22632A	RM 75.0 1/4W F
R347L, R	OB22794A	RM 46.4 1/4W F
R348L, R	OB22794A	RM 46.4 1/4W F
R349L, R	OB25485A	RM 1.00K 1/4W F
R350L, R	OB09419A	RM 2.00K 1/4W F
R351L, R	OB25487A	RM 220 1/4W F
R352L, R	OB25487A	RM 220 1/4W F
R353L, R	OB22753A	RM 33.2 1/4W F
R354L, R	OB22753A	RM 33.2 1/4W F
R355L, R	OB25087A	RM 75.0 1/4W F
C340L, R	OB41540A	C 100P 100V J
C341L, R	OB41972A	CSP 2700P 50V J
C342L, R	OB09249A	C 33P 50V J
C343, 344	OB40420A	CE 220u 16V (LN)

- Digital Power Supply -

Ref. No.	Part No.	Description
U301	OB11609A	IC NJM78M05FA
U302	OB11576A	IC NJM78L02A
Q301	OB10296A	TR 2SC3852
Q302	OB06322A	TR 2SC2002 (K, L)
Q303	OB06372A	TR 2SA953 (K, L)
Q304	OB10050A	TR 2SA970 (BL)
Q305, 306	OB10270A	TR 2SA770
Q307	OB06322A	TR 2SC2002 (K, L)
Q308, 309	OB06142A	TR 2SC2240 (BL)
Q310, 311	OB06142A	TR 2SC2240 (BL)
Q313	OB10050A	TR 2SA970 (BL)
Q314	OB06142A	TR 2SC2240 (BL)
Q315	OB06316A	TR 2SD882 (P, Q)
Q316, 317	OB06142A	TR 2SC2240 (BL)
ZD301	OB12174A	ZD 12V RD12JSB2
ZD302, 303	OB12168A	ZD 10V RD10JSB2
ZD304	OB12144A	ZD 4.7V RD4.7JSB2
D301	OB06282A	SiD Diode Bridge DBA10B
D302	OB06398A	SiD 1SS176
D303	OB06282A	SiD Diode Bridge DBA10B
D304	OB12387A	SiD Diode Bridge RBV402
D305	OB12634A	Varistor SV02YS
D306, 307	OB06398A	SiD 1SS176
D308, 309	OB06109A	SiD GP08B
D310, 311	OB06398A	SiD 1SS176
D312, 313	OB06398A	SiD 1SS176
R301	OB09685A	RK 2.2K 1/6W J
R302, 303	OB09697A	RK 6.8K 1/6W J

Ref. No.	Part No.	Description
R304	OB09693A	RK 4.7K 1/6W J
R305	OB09699A	RK 8.2K 1/6W J
R306	OB09677A	RK 1.0K 1/6W J
R307	OB09671A	RK 560 1/6W J
R308, 309	OB24052A	RF 1.0 2W J
R310	OB09647A	RK 56 1/6W J
R311	OB09677A	RK 1.0K 1/6W J
R312	OB22273A	RM 2.55K 1/6W F
R313	OB22272A	RM 2.49K 1/6W F
R314	OB09719A	RK 56K 1/6W J
R315, 316	OB09701A	RK 10K 1/6W J
R321	OB09673A	RK 680 1/6W J
R322	OB09717A	RK 47K 1/6W J
R323, 324	OB09701A	RK 10K 1/6W J
R325	OB09719A	RK 56K 1/6W J
R326, 327	OB09701A	RK 10K 1/6W J
R328	OB09693A	RK 4.7K 1/6W J
R329	OB09719A	RK 56K 1/6W J
R330	OB09713A	RK 33K 1/6W J
C301, 302	OB41823A	CML 0.01u 50V J
C303, 304	OB41823A	CML 0.01u 50V J
C305, 306	OB40586A	CE 2200u 25V
C307, 308	OB01400A	CE 100u 16V
C309, 310	OB01400A	CE 100u 16V
C311, 312	OB01400A	CE 100u 16V J
C313, 314	OB41823A	CML 0.01u 50V J
C315, 316	OB41823A	CML 0.01u 50V J
C317	OB40605A	CE 2200u 16V
C318	OB41304A	CML 0.33u 50V J
C319	OB41298A	CML 0.1u 50V J
C320, 321	OB41823A	CML 0.01u 50V J
C322, 323	OB41823A	CML 0.01u 50V J
C324	OB40540A	CE 10000u 16V
C325	OB41298A	CML 0.1u 50V J
C326, 327	OB01405A	CE 1u 50V
C328	OB40067A	CE 470u 10V
C330	OB40081A	CE 470u 16V
C331	OB01674A	CE 10u 25V
C332	OB40081A	CE 470u 16V
C333	OB01405A	CE 1u 50V
C334	OB01674A	CE 10u 25V
C335	OB09332A	CE 2.2u 50V (LN)
C336	OB40540A	CE 10000u 16V
	OJ05813A	Heat Sink AS02C (2)
	OJ05814A	Heat Sink AS02D (1)
	OE03319A	M3x8 + Binding (3)

- Miscellaneous Part -

Ref. No.	Part No.	Description
F301, 302	OB60664B	Digital Power Supply P.C.B.
F301, 302	OB90376A	Fuse 2A 125V (USA, CAN, JPN)
F301, 302	OB90384A	Fuse T2A 250V (UK, OTR, AUS, EP, SWT)
F303, 304	OB90376A	Fuse 2A 125V (USA, CAN, JPN)
F303, 304	OB90384A	Fuse T2A 250V (UK, OTR, AUS, EP, SWT)
F305, 306	OB90373A	Fuse 1A 250V (USA, CAN, JPN)
F305, 306	OB90381A	Fuse T1A 250V (UK, OTR, AUS, EP, SWT)
F307	OB90373A	Fuse 1A 250V (USA, CAN, JPN)
F307	OB90381A	Fuse T1A 250V (UK, OTR, AUS, EP, SWT)
F308	OB90379A	Fuse 4A 125V (USA, CAN, JPN)
F308	OB90387A	Fuse T4A 250V (UK, OTR, AUS, EP, SWT)
CN119	OB81027A	4P T-Post White
CN120	OB81029A	6P T-Post White
CN121	OB81231A	4P T-Post White
CN122	OB81223A	2P T-Post White
CN124	OB81059A	8P T-Post Red
CN125	OB81025A	2P T-Post White
CN126	OB81223A	2P T-Post White
CN130	OB84044A	3P T-Post Gold
CN132	OB81227A	3P T-Post White
CN301, 302	OB84044A	3P T-Post Gold
CN305	OB84046A	7P T-Post Gold
CN401	OB84044A	3P T-Post Gold
CN403	OB84044A	3P T-Post Gold
	OB90401A	Heat Sink (1)
	OE00507A	Nut 3mm (1)
	OE00521A	M3x8 + Pan (1)
	OE03319A	M3x8 + Binding (1)
	OJ05918A	Heat Sink (1)

Ref. No.	Part No.	Description
	OJ05960A	P.C.B. Bush N (5)
	OJ05961A	P.C.B. Collar N (5)
	OB90278A	Fuse Holder (F-211P) (16)

7.8. Display P.C.B. Ass'y

Ref. No.	Part No.	Description
	BA07468B	Display P.C.B. Ass'y
	OB60671B	Display P.C.B.
Q606	OB06142A	TR 2SC2240 (BL)
Q607	OB10050A	TR 2SA970 (BL)
Q608	OB06142A	TR 2SC2240 (BL)
Q609	OB10270A	TR 2SA770
Q610	OB06142A	TR 2SC2240 (BL)
Q611	OB10050A	TR 2SA970 (BL)
Q612	OB06142A	TR 2SC2240 (BL)
Q613	OB10270A	TR 2SA770
QA614, 615	OB14171A	Transistor Array LB1213M
QA616, 617	OB14171A	Transistor Array LB1213M
QA618	OB14171A	Transistor Array LB1213M
IP614	OB11335A	IC ICP-N15-T104
ED607	OB12633A	LED Display SLA-6653
RA601, 602	OB21054A	R-Network 150x7
RA603, 604	OB21054A	R-Network 150x7
RA605	OB21054A	R-Network 150x7
R610	OB24057A	RF 1.0 2W
R611, 612	OB09701A	RK 10K 1/6W J
R613	OB09677A	RK 1.0K 1/6W J
R614	OB09650A	RK 75 1/6W J
R615	OB09655A	RK 120 1/6W J
R616	OB09677A	RK 1.0K 1/6W J
R617, 618	OB09701A	RK 10K 1/6W J
R619	OB09655A	RK 120 1/6W J
R620	OB09650A	RK 75 1/6W J
C604	OB40611A	CE 330u 6.3V
C605	OB40666A	CE 100u 6.3V
CN601	OB84001A	40P FC-Connector
	OE00507A	Nut 3mm (1)
	OE00612A	M3x6 + Pan (2A) (1)
	OE00859A	BT.2.6x6 + Binding (2)

7.9. Function Switch P.C.B. Ass'y

Ref. No.	Part No.	Description
	BA07467B	Function Switch P.C.B. Ass'y
	OB60670C	Function Switch P.C.B.
Q601	OB10060A	TR DTA143ES
Q602, 603	OB10062A	TR DTC144ES
Q604, 605	OB10062A	TR DTC144ES
ED603, 604	OB12641A	LED Umber
ED605, 606	OB12641A	LED Umber
D601	OB06398A	SiD 1SS176
R601	OB09677A	RK 1.0K 1/6W J
R602	OB09701A	RK 10K 1/6W J
R603, 604	OB09661A	RK 220 1/6W J
C604	OB09332A	CE 2.2u 50V (LN)

Ref. No.	Part No.	Description
D607, 608	OB06398A	SiD 1SS176
X601	OB92020A	X'Tal 6.0MHz
R605, 606	OB09701A	RK 10K 1/6W J
R607	OB09749A	RK 1.0M 1/6W J
R608	OB09701A	RK 10K 1/6W J
R609	OB09717A	RK 47K 1/6W J
R610	OB09725A	RK 100K 1/6W J
R611	OB09701A	RK 10K 1/6W J
R612	OB09693A	RK 4.7K 1/6W J
R701	OB09725A	RK 100K 1/6W J
R702, 703	OB09701A	RK 10K 1/6W J
R704	OB09693A	RK 4.7K 1/6W J
R705, 706	OB09701A	RK 10K 1/6W J
R707, 708	OB09701A	RK 10K 1/6W J
C601	OB41306A	CML 0.47u 50V J
C602, 603	OB41512A	C 10P 50V D
C604	OB09282A	CC 100P 50V K
C701	OB41292A	CML 0.033u 50V J
C702, 703	OB41971A	CC 0.1u 50V Z
C704, 705	OB41971A	CC 0.1u 50V Z
S701	OB70095A	DIP Switch (DSS108)
CN104	OB81032A	9P T-Post White
CN105	OB81033A	10P T-Post White
CN106	OB81031A	8P T-Post White
CN108	OB81034A	11P T-Post White
CN129	OB81028A	5P T-Post White
CN601	OB84002A	40P Connector (XG4C-4031)

7.11. Mother P.C.B. Ass'y

Ref. No.	Part No.	Description
	BA07464B	Mother P.C.B Ass'y
C390	OB60667B	Mother P.C.B
C391	OB41944A	CC 0.047u 25V
CN101	OB84006A	DIN Connector J100P (XC5B-0121)
CN102	OB84006A	DIN Connector J100P (XC5B-0121)
CN103	OB84006A	DIN Connector J100P (XC5B-0121)
CN104	OB81032A	9P T-Post White
CN105	OB81033A	10P T-Post White
CN107	OB81035A	12P T-Post White
CN108	OB81034A	11P T-Post White
CN109	OB81231A	4P T-Post White
CN111	OB81232A	4P T-Post Black
CN113	OB81233A	4P T-Post Red
CN115	OB81234A	4P T-Post Yellow
CN117	OB84044A	3P T-Post Gold
CN118	OB84044A	3P T-Post Gold
CN119	OB81027A	4P T-Post White
CN120	OB81239A	6P T-Post White
CN121	OB81231A	4P T-Post White
CN122	OB81223A	2P T-Post White
CN123	OB81055A	4P T-Post Red
CN131	OB81233A	4P T-Post Red
CN150	OB83606A	GND E Ass'y
	OE03502A	Washer 2.6mm (Spring) (6)
	OE03503A	Nut 2.6mm (6)
	OE03504A	M2.6x8 + Pan (6)

7.12. DAC P.C.B. Ass'y

Ref. No.	Part No.	Description
HA05757A		DAC P.C.B. Ass'y [N-1000P]
HA05759A		DAC P.C.B. Ass'y [N-1000P Pro.] (UK, OTR, AUS, EP, SWT)
HA05758A		DAC P.C.B. Ass'y [N-1000P Pro.] (JPN, USA, CAN)
- Main Part -		
U800	OB60661C	DAC P.C.B.
U801	OB11558A	IC TC74HC08AP
U802	OB11546A	IC SM5803
U803	OB11660A	IC TC74F02AF
	OB11662A	IC TC74F74

Ref. No.	Part No.	Description
U804	OB11661A	IC TC74F08
U805	OB11662A	IC TC74F74
U806	OB11659A	IC TC74F00
U807	OB11663A	IC TC74F163
U808	OB11549A	IC MB7112E
U809	OB11664A	IC TC74F374
U818L, R	OB11724A	IC 74HC674
U819L, R	OB11724A	IC 74HC674
U821L, R	OB11660A	IC TC74F02AF
U880L, R	OB11547A	IC TDA1541S1
U881L, R	OB11709A	IC NE5534AN
U882L, R	OB11709A	IC NE5534AN
U883L, R	OB11376A	IC 27GN8
U884L, R	OB11710A	IC NE5532AN
Q820L, R	OB06142A	TR 2SC2240 (BL)
Q821L, R	OB06142A	TR 2SC2240 (BL)
Q823L, R	OB06142A	TR 2SC2240 (BL)
Q824L, R	OB10050A	TR 2SA970 (BL)
Q825L, R	OB10050A	TR 2SA970 (BL)
Q826L, R	OB10050A	TR 2SA970 (BL)
Q827L, R	OB10050A	TR 2SA970 (BL)
Q828L, R	OB10275A	TR 2SC1845
Q829L, R	OB10269A	TR 2SC3244
Q830L, R	OB10268A	TR 2SA1284
Q831L, R	OB06142A	TR 2SC2240 (BL)
Q832L, R	OB10050A	TR 2SA970 (BL)
Q833L, R	OB06142A	TR 2SC2240 (BL)
Q834L, R	OB10282A	TR 2SC3851
Q835L, R	OB10050A	TR 2SA970 (BL)
Q836L, R	OB06142A	TR 2SC2240 (BL)
Q837L, R	OB10050A	TR 2SA970 (BL)
Q838L, R	OB06142A	TR 2SC2240 (BL)
Q839L, R	OB10050A	TR 2SA970 (BL)
Q840L, R	OB06142A	TR 2SC2240 (BL)
Q841L, R	OB10050A	TR 2SA970 (BL)
Q842L, R	OB06142A	TR 2SC2240 (BL)
Q843L, R	OB10050A	TR 2SA970 (BL)
Q844L, R	OB10050A	TR 2SA970 (BL)
Q845L, R	OB06142A	TR 2SC2240 (BL)
Q846L, R	OB10050A	TR 2SA970 (BL)
Q847L, R	OB10050A	TR 2SA970 (BL)
Q848L, R	OB06142A	TR 2SC2240 (BL)
Q849L, R	OB06142A	TR 2SC2240 (BL)
Q850L, R	OB10050A	TR 2SA970 (BL)
Q851L, R	OB06142A	TR 2SC2240 (BL)
Q852L, R	OB10050A	TR 2SA970 (BL)
Q853L, R	OB10062A	TR DTC144ES
Q854L, R	OB10281A	TR 2SA1488
Q855L, R	OB10068A	TR DTC114ES
ZD81L, R	OB12150A	ZD 5.6V RD5.6JSB2
ZD82L, R	OB12150A	ZD 5.6V RD5.6JSB2
ZD83L, R	OB12180A	ZD 15V RD15JSB2
ZD84L, R	OB12180A	ZD 15V RD15JSB2
ZD85L, R	OB12180A	ZD 15V RD15JSB2
ZD86L, R	OB12180A	ZD 15V RD15JSB2
ZD87L, R	OB12180A	ZD 15V RD15JSB2
D820L, R	OB12634A	Varistor
D821L, R	OB12634A	Varistor
D822L, R	OB12634A	Varistor
D823L, R	OB06398A	SiD 1SS176
D824L, R	OB12635A	Varistor
D825L, R	OB12634A	Varistor
D826L, R	OB12634A	Varistor
D828L, R	OB12634A	Varistor
D829L, R	OB12634A	Varistor
D830L, R	OB12634A	Varistor
D831L, R	OB12634A	Varistor
D832L, R	OB12634A	Varistor
D833L, R	OB06398A	SiD 1SS176
D834L, R	OB06398A	SiD 1SS176
D835L, R	OB06398A	SiD 1SS176
D836L, R	OB19009A	CRD E-102
D837	OB06398A	SiD 1SS176
L80, 81	OB51183A	Micro Coil 100 uH
VR80L, R	OB32115A	Semi VR 10K
R802L, R	OB09529A	RM 6.80K 1/4W F
R803L, R	OB09529A	RM 6.80K 1/4W F
R820L, R	OB09900A	RM 4.99K 1/4W F
R821L, R	OB22790A	RM 1.91K 1/4W F
R822L, R	OB25487A	RM 220 1/4W F
R823L, R	OB09230A	RM 1.50K 1/4W F

Ref. No.	Part No.	Description
R824L, R	OB22779A	RM 768 1/4W F
R825L, R	OB22777A	RM 62.0K 1/4W F
R826L, R	OB22666A	RM 10.0 1/4W F
R827L, R	OB22766A	RM 1.4K 1/4W F
R828L, R	OB22766A	RM 1.4K 1/4W F
R829L, R	OB09757A	RM 1.54K 1/4W F
R830L, R	OB09757A	RM 1.54K 1/4W F
R831L, R	OB22633A	RM 150 1/4W F
R832L, R	OB22633A	RM 150 1/4W F
R833L, R	OB22561A	RM 121 1/4W F
R834L, R	OB22561A	RM 121 1/4W F
R835L, R	OB22633A	RM 150 1/4W F
R836L, R	OB09553A	RM 27.4K 1/4W F
R837L, R	OB22697A	RM 511 1/4W F
R838L, R	OB22697A	RM 511 1/4W F
R839L, R	OB09496A	RM 68.1 1/4W F
R840L, R	OB09496A	RM 68.1 1/4W F
R841L, R	OB09305A	RM 100K 1/4W F
R842L, R	OB09305A	RM 100K 1/4W F
R843L, R	OB09446A	RM 33.2K 1/4W F
R844L, R	OB22646A	RM 909 1/4W F
R845L, R	OB22567A	RM 100 1/4W F
R846L, R	OB09453A	RM 51.1K 1/4W F
	[N-1000P]	
R846L, R	OB09760A	RM 332K 1/4W F
	[N-1000P Pro.]	
R847L, R	OB09453A	RM 51.1K 1/4W F
	[N-1000P]	
R847L, R	OB02280A	RM 21K 1/4W F
	[N-1000P Pro.]	
R848L, R	OB09444A	RM 27.0K 1/4W F
	[N-1000P]	
R848L, R	OB09453A	RM 51.1K 1/4W F
	[N-1000P Pro.]	
R849L, R	OB22729A	RM 10.0K 1/4W F
R850L, R	OB22729A	RM 10.0K 1/4W F
R851L, R	OB09795A	RM 5.1K 1/4W F
R852L, R	OB22631A	RM 47.0 1/4W F
R853L, R	OB22631A	RM 47.0 1/4W F
R854L, R	OB09446A	RM 33.2K 1/4W F
R855L, R	OB22693A	RM 200 1/4W F
R856L, R	OB22693A	RM 200 1/4W F
R857L, R	OB22693A	RM 200 1/4W F
R858L, R	OB09420A	RM 2.2K 1/4W F
R859L, R	OB22576A	RM 475 1/4W F
R860L, R	OB22576A	RM 475 1/4W F
R861L, R	OB22576A	RM 475 1/4W F
R862L, R	OB22576A	RM 475 1/4W F
R863L, R	OB22576A	RM 475 1/4W F
R864L, R	OB22693A	RM 200 1/4W F
R865L, R	OB22693A	RM 200 1/4W F
R866L, R	OB09446A	RM 33.2K 1/4W F
R867L, R	OB22674A	RM 130 1/4W F
R868L, R	OB22729A	RM 10.0K 1/4W F
R869L, R	OB09446A	RM 33.2K 1/4W F
R870L, R	OB22693A	RM 200 1/4W F
R871L, R	OB22693A	RM 200 1/4W F
R872L, R	OB22576A	RM 475 1/4W F
R873L, R	OB22576A	RM 475 1/4W F
R874L, R	OB09578A	RM 6.19K 1/4W F
R875L, R	OB09305A	RM 100K 1/4W F
R876L, R	OB22729A	RM 10.0K 1/4W F
R877L, R	OB22576A	RM 475 1/4W F
R878	OB22729A	RM 10.0K 1/4W F
R879L, R	OB22567A	RM 100 1/4W F
R880L, R	OB09461A	RM 90.9K 1/4W F
R882L, R	OB25487A	RM 220 1/4W F
R883L, R	OB09204A	RM 470 1/4W F
R884L, R	OB09204A	RM 470 1/4W F
R885	OB22765A	RM 432 1/4W F
R886	OB09795A	RM 5.10K 1/4W F
R887L, R	OB22567A	RM 100 1/4W F
R888L, R	OB22567A	RM 100 1/4W F
R893L, R	OB24221A	RF 120 1/2W J
R894L, R	OB24221A	RF 120 1/2W J
R895L, R	OB09420A	RM 2.20K 1/4W F
R896L, R	OB22736A	RM 35.7K 1/4W F
	[N-1000P Pro.]	
R899	OB09725A	RK 100K 1/6W J
C800	OB41971A	CC 0.10u 50V Z
C805	OB40579A	CT 10u 16V
C806	OB40620A	CE 1000u 25V

Ref. No.	Part No.	Description
C807	OB40579A	CT 10u 16V
C809, 810	OB41971A	CC 0.10u 50V Z
C811, 812	OB41971A	CC 0.10u 50V Z
C813, 814	OB41971A	CC 0.10u 50V Z
C815, 816	OB41971A	CC 0.10u 50V Z
C824L, R	OB41971A	CC 0.10u 50V Z
C825L, R	OB41971A	CC 0.10u 50V Z
C827L, R	OB41971A	CC 0.10u 50V Z
C829	OB40579A	CT 10u 16V
C830	OB40579A	CT 10u 16V
C831	OB40579A	CT 10u 16V
C832L, R	OB41512A	C 10P 50V D
C833L, R	OB41512A	C 10P 50V D
C834L, R	OB41200A	C 47P 50V J
C835L, R	OB41988A	CML 0.22u 63V K
C836L, R	OB41988A	CML 0.22u 63V K
C840L, R	OB41984A	CML 0.1u 63V J
C841L, R	OB41984A	CML 0.1u 63V J
C842L, R	OB41984A	CML 0.1u 63V J
C843L, R	OB41984A	CML 0.1u 63V J
C844L, R	OB41984A	CML 0.1u 63V J
C845L, R	OB41984A	CML 0.1u 63V J
C846L, R	OB41984A	CML 0.1u 63V J
C847L, R	OB41984A	CML 0.1u 63V J
C848L, R	OB41984A	CML 0.1u 63V J
C849L, R	OB41984A	CML 0.1u 63V J
C850L, R	OB41984A	CML 0.1u 63V J
C851L, R	OB41984A	CML 0.1u 63V J
C852L, R	OB41984A	CML 0.1u 63V J
C853L, R	OB41984A	CML 0.1u 63V J
C854L, R	OB41803A	C 470P 50V J
C855L, R	OB41988A	CML 0.22u 63V K
C856L, R	OB41988A	CML 0.22u 63V K
C857L, R	OB40563A	CE 10u 35V (LN)
C858L, R	OB41988A	CML 0.22u 63V K
C859L, R	OB40563A	CE 10u 35V (LN)
C860L, R	OB40181A	CE 100u 6.3V (LN)
C861L, R	OB41176A	CML 0.22u 63V J
C862L, R	OB40181A	CE 100u 6.3V (LN)
C863L, R	OB41985A	CSP 1800P 50V J
C864L, R	OB41985A	CSP 1800P 50V J
C865L, R	OB41988A	CML 0.22u 63V K
C866L, R	OB41988A	CML 0.22u 63V K
C867L, R	OB41988A	CML 0.22u 63V K
C869L, R	OB47002A	CSP 1500P 50V J
C870L, R	OB47002A	CSP 1500P 50V J
C872L, R	OB41984A	CML 0.1u 63V J
C873L, R	OB41972A	CSP 2700P 50V J
C874L, R	OB41305A	CML 0.39u 50V J
C875L, R	OB41305A	CML 0.39u 50V J
C876L, R	OB41791A	CSP 1000P 50V J
C877L, R	OB40563A	CE 10u 35V (LN)
	[N-1000P]	
C877L, R	OB40609A	CE 22u 25V (LN)
	[N-1000P Pro.]	
C878L, R	OB47001A	C 22P 50V J

Ref. No.	Part No.	Description
RY82L, R	OB90361A	Rylay AG2323
S820	OB70078A	Slide SW 2-2 (SSSP-12)
TF81L, R	OB90322A	Thermal Fuse 126
TF82L, R	OB90322A	Thermal Fuse 126
TF83L, R	OB90322A	Thermal Fuse 126
TF84L, R	OB90322A	Thermal Fuse 126
TF85L, R	OB90322A	Thermal Fuse 126
TF86L, R	OB90322A	Thermal Fuse 126
JS80	OB84041A	Shorting Connector 14P
JS81L, R	OB84042A	Shorting Connector 2P
JS82L, R	OB84042A	Shorting Connector 2P
JS83L, R	OB84042A	Shorting Connector 2P
PJ81	OB84039A	B-B Connector 14P
PJ82L, R	OB84001A	B-B Connector 40P
CN81L	OB83562B	3P H Connector Ass'y 170
CN81R	OB83563B	3P H Connector Ass'y 80
CN82L	OB83566B	2P H Connector Ass'y 90
CN82R	OB83567B	2P H Connector Ass'y 60
CN83L	OB83668B	2P H Connector Ass'y 80
CN83R	OB83669B	2P H Connector Ass'y 150
CN84L-CN86	OB83568A	2P H Connector Ass'y 500
CN84R-CN87	OB83569A	2P H Connector Ass'y 500
CN85L-CN88	OB83564A	2P H Connector Ass'y 500
CN85R-CN89	OB83565A	2P H Connector Ass'y 500
	OB80220A	Bus Bar B (4)
	OJ05842B	Bus Bar B (1)
	OB83816A	DAC P.C.B. OFC 165mm (1)
	OB83817A	DAC P.C.B. OFC 155mm (1)
	OB83818A	DAC P.C.B. OFC 115mm (1)
	OB83819A	DAC P.C.B. OFC 90mm (2)
	OB83820A	DAC P.C.B. OFC 145mm (1)
	OB84043A	Short Socket 2P (11)
	OB90390A	Stud (6)
	OJ05048A	P.C.B. Spacer (4)
	OJ05814A	Heat Sink (4)
	OJ05844D	DA. Earth Plate
- Sub Part -		
U810L, R	OB60689B	DAC Sub P.C.B.
U812L, R	OB11723A	IC 74HC673
U813	OB11658A	IC TC74HC374AP
U814L, R	OB11560A	IC TC74HC32AP
U814L, R	OB11658A	IC TC74HC374AP
U815L, R	OB11658A	IC TC74HC374AP
U816L, R	OB11550A	IC SN74LS83AN
U817L, R	OB11550A	IC SN74LS83AN
U820L, R	OB11722A	IC GAL 16V8-25LP
C817L, R	OB41971A	CC 0.1u 50V Z
C818L, R	OB41971A	CC 0.1u 50V Z
C819L, R	OB41971A	CC 0.1u 50V Z
C820L, R	OB41971A	CC 0.1u 50V Z
C821L, R	OB41971A	CC 0.1u 50V Z
C822L, R	OB41971A	CC 0.1u 50V Z
C823L, R	OB41971A	CC 0.1u 50V Z
C825L, R	OB41971A	CC 0.1u 50V Z
C837, 838	OB40579A	CT 10u 16V
C839	OB40579A	CT 10u 16V
C871	OB41971A	CC 0.1u 50V J
PJ83	OB84040A	FC Connector 14P
PJ84L, R	OB84002A	FC Connector 40P
	OB84038A	28P IC Socket (XR2A-2801) (2)
- Pin Jack Part -		
R889L, R	OB60724A	Pin Jack P.C.B.
R890L, R	OB25487A	RM 220 1/4W F
	OB25487A	RM 220 1/4W F
- Cannon Connector Part -		
R891L, R	OB60725A	Cannon Connector P.C.B.
R892L, R	OB22702A	RM 27.4 1/4W F
	OB22702A	RM 27.4 1/4W F
- Miscellaneous Part -		
U811L, R	OB11575A	IC 27C128-25
CN102	OB84005A	DIN Connector P100P
	OJ05839B	DA. Digital Box (1)
	OJ05943A	Wire Cover (2)

Ref. No.	Part No.	Description
	OB84007A	1P Pin Jack (AU) (4)
	OB84101A	Cannon Connector (2)
	OE03030A	M3x6 + Binding (Nickel) (29)
	OE03030A	M3x6 + Binding (Nickel) (23)
	OE03502A	Spring Washer 2.6mm (Nickel) (2)
	OE03503A	Nut Hex. 2.6mm (Nickel) (2)
	OE03516A	M3x6 + Oval (Nickel) (4)
	OE03523A	M2.6x10 + Pan (Nickel) (2)
	OH05462C	DAC Panel 101P [N-1000P] (1)
	OH05560B	DAC Panel 102P (1)
		(USA, CAN, JPN)
		[N-1000P Pro.]
	OH05570B	DAC Panel 103P (1)
		(UK, OTR, AUS, EP, SWT)
		[N-1000P Pro.]
	OB08515A	Insu-Lock [N-1000P Pro.] (10)
7.13. ADC P.C.B. Ass'y		
Ref. No.	Part No.	Description
	HA05754A	ADC P.C.B. Ass'y [N-1000P]
	HA05756A	ADC P.C.B. Ass'y [N-1000P Pro.]
		(UK, OTR, AUS, EP, SWT)
	HA05755A	ADC P.C.B. Ass'y [N-1000P Pro.]
		(JPN, USA, CAN)
- Main Part -		
	OB60660C	ADC P.C.B.
U101L, R	OB11710A	IC NE5532AN
U102L, R	OB11710A	IC NE5532AN
U103L, R	OB11710A	IC NE5532AN
U104L, R	OB11376A	IC OP-27GN8
U105L, R	OB11565A	IC AK9201
U106	OB11564A	IC TC74HC00AP
U108	OB11561A	IC TC74HC74AP
U109, 110	OB11559A	IC TC74HC161AP
U111	OB11557A	IC TC74HC04AP
U113	OB11566A	IC SM5805
U202L, R	OB11709A	IC NE5534AN
Q101L, R	OB10014A	TR 2SA992
Q102L, R	OB06142A	TR 2SC2240 (BL)
Q103L, R	OB06142A	TR 2SC2240 (BL)
Q104L, R	OB10188A	FET 2SK240 (BL)
Q105L, R	OB10050A	TR 2SA970 (BL)
Q106L, R	OB10014A	TR 2SA992
Q107L, R	OB10269A	TR 2SC3244
Q108L, R	OB10276A	FET 2SJ75 (BL)
Q109L, R	OB10050A	TR 2SA970 (BL)
Q110L, R	OB10050A	TR 2SA970 (BL)
Q111L, R	OB10275A	TR 2SC1845
Q112L, R	OB10275A	TR 2SC1845
Q113L, R	OB10268A	TR 2SA1284
Q114L, R	OB06142A	TR 2SC2240 (BL)
Q115L, R	OB06142A	TR 2SC2240 (BL)
Q116L, R	OB10050A	TR 2SA970 (BL)
Q117L, R	OB06142A	FET 2SC2240 (BL)
Q118L, R	OB10050A	TR 2SA970 (BL)
Q119L, R	OB10269A	TR 2SC3244
Q120L, R	OB10050A	FET 2SA970 (BL)
Q121L, R	OB06142A	TR 2SC2240 (BL)
Q122L, R	OB06142A	TR 2SC2240 (BL)
Q123L, R	OB10268A	TR 2SA1284
Q124L, R	OB06142A	TR 2SC2240 (BL)
Q125L, R	OB10050A	TR 2SA970 (BL)
Q201L, R	OB06142A	TR 2SC2240 (BL)
Q202L, R	OB10050A	TR 2SA970 (BL)
Q203L, R	OB06142A	TR 2SC2240 (BL)
Q204L, R	OB10050A	TR 2SA970 (BL)
Q205L, R	OB10050A	TR 2SA970 (BL)
Q206L, R	OB06142A	TR 2SC2240 (BL)
Q207L, R	OB06142A	TR 2SC2240 (BL)
Q208L, R	OB10050A	TR 2SA970 (BL)
Q209L, R	OB06142A	TR 2SC2240 (BL)
Q210L, R	OB10050A	TR 2SA970 (BL)

Ref. No.	Part No.	Description
Q211L, R	OB10050A	TR 2SA970 (BL)
Q212L, R	OB06142A	TR 2SC2240 (BL)
Q213L, R	OB06142A	TR 2SC2240 (BL)
Q214L, R	OB10050A	TR 2SA970 (BL)
Q215L, R	OB06142A	TR 2SC2240 (BL)
Q219L, R	OB10050A	TR 2SA970 (BL)
Q220L, R	OB10125A	TR 2SC2259 (F, G, H)
Q221L, R	OB06142A	TR 2SC2240 (BL)
Q222L, R	OB10050A	TR 2SA970 (BL)
Q223L, R	OB10269A	TR 2SC3244
Q224L, R	OB10050A	TR 2SA970 (BL)
Q225L, R	OB10268A	TR 2SA1284
Q226L, R	OB06142A	TR 2SC2240 (BL)
Q231L, R	OB06142A	TR 2SC2240 (BL)
Q232L, R	OB10050A	TR 2SA970 (BL)
Q233L, R	OB06142A	TR 2SC2240 (BL)
Q234L, R	OB10050A	TR 2SA970 (BL)
Q235L, R	OB10050A	TR 2SA970 (BL)
Q236L, R	OB06142A	TR 2SC2240 (BL)
Q237	OB06142A	TR 2SC2240 (BL)
ZD11L, R	OB12144A	ZD 4.7V RD4.7JSB2
ZD12L, R	OB12144A	ZD 4.7V RD4.7JSB2
ZD15L, R	OB12180A	ZD 15V RD15JSB2
ZD16L, R	OB12180A	ZD 15V RD15JSB2
ZD21L, R	OB12180A	ZD 15V RD15JSB2
ZD22L, R	OB12180A	ZD 15V RD15JSB2
ZD23L, R	OB12180A	ZD 15V RD15JSB2
ZD24L, R	OB12180A	ZD 15V RD15JSB2
ZD25L, R	OB12180A	ZD 15V RD15JSB2
ZD26L, R	OB12180A	ZD 15V RD15JSB2
ZD27L, R	OB12147A	ZD 5.1V RD5.1JSB2
ZD28L, R	OB12147A	ZD 5.1V RD5.1JSB2
D101L, R	OB12635A	Varistor
D102L, R	OB06181A	SID 1SS53
D103L, R	OB12635A	Varistor
D105	OB06398A	SID 1SS176
D110L, R	OB12634A	Varistor
D111L, R	OB12634A	Varistor
D201L, R	OB12634A	Varistor
D202L, R	OB12634A	Varistor
D203L, R	OB12634A	Varistor
D204L, R	OB12634A	Varistor
D205L, R	OB12634A	Varistor
D206L, R	OB12634A	Varistor
D207L, R	OB12634A	Varistor
D208L, R	OB12634A	Varistor
D211L, R	OB12634A	Varistor
D212L, R	OB12634A	Varistor
D213	OB06181A	SID 1SS53
X101	OB92019A	X'tal 24.576MHz
X102	OB92018A	X'tal 24.579MHz
		[N-1000P Pro.]
L101	OB51126A	Coil 100uH
VR201L, R	OB32153A	Semi VR 10K
R101L, R	OB22567A	RM 100 1/4W F
R102L, R	OB09318A	RM 560K 1/4W F
R103L, R	OB22706A	RM 562 1/4W F
R104L, R	OB09491A	RM 1.00K 1/4W F
R105L, R	OB22706A	RM 562 1/4W F
R106L, R	OB22561A	RM 121 1/4W F
R107L, R	OB09230A	RM 1.50K 1/4W F
R108L, R	OB09230A	RM 1.50K 1/4W F
R109L, R	OB22561A	RM 121 1/4W F
R110L, R	OB22706A	RM 562 1/4W F
R111L, R	OB09491A	RM 1.00K 1/4W F
R112L, R	OB22706A	RM 562 1/4W F
R113L, R	OB22729A	RM 10.0K 1/4W F
R114L, R	OB22783A	RM 86.6 1/4W F
R115L, R	OB22783A	RM 86.6 1/4W F
R116L, R	OB22782A	RM 30.1 1/4W F
R117L, R	OB22782A	RM 30.1 1/4W F
R118L, R	OB22729A	RM 10.0K 1/4W F
R119L, R	OB22785A	RM 1.43K 1/4W F
R120L	OB22713A	RM 536 1/4W F
R120R	OB09502A	RM 1.00M 1/4W F
R121L	OB09502A	RM 1.00M 1/4W F
R121R	OB22713A	RM 536 1/4W F
R122L, R	OB01888A	RK 10K 1/4W J
R123L, R	OB01888A	RK 10K 1/4W J
R124L, R	OB09596A	RM 2.43K 1/4W F
R125L, R	OB09418A	RM 1.58K 1/4W F
R126L, R	OB09418A	RM 1.58K 1/4W F

Ref. No.	Part No.	Description
R127L, R	OB09762A	RM 2.80K 1/4W F
R128L, R	OB09421A	RM 2.67K 1/4W F
R129L, R	OB09418A	RM 1.58K 1/4W F
R130L, R	OB09418A	RM 1.58K 1/4W F
R131L, R	OB09547A	RM 2.21K 1/4W F
R132L, R	OB22752A	RM 1.65K 1/4W F
R133L, R	OB22798A	RM 348 1/4W F
R134L, R	OB09418A	RM 1.58K 1/4W F
R135L, R	OB09418A	RM 1.58K 1/4W F
R136L, R	OB22550A	RM 1.02K 1/6W F
R137L, R	OB09502A	RM 1.00M 1/4W F
R138L, R	OB22706A	RM 562 1/4W F
R139L, R	OB22633A	RM 150 1/4W F
R140L, R	OB22706A	RM 562 1/4W F
R142L, R	OB22783A	RM 86.6 1/4W F
R143L, R	OB22788A	RM 6.65K 1/4W F
R144L, R	OB09496A	RM 68.1 1/4W F
R145L, R	OB22693A	RM 200 1/4W F
R146L, R	OB09496A	RM 68.1 1/4W F
R148L, R	OB22706A	RM 562 1/4W F
R149L, R	OB22633A	RM 150 1/4W F
R150L, R	OB22706A	RM 562 1/4W F
R151L, R	OB22783A	RM 86.6 1/4W F
R152L, R	OB09540A	RM 3.24K 1/4W F
R153L, R	OB09305A	RM 100K 1/4W F
R154L, R	OB09305A	RM 100K 1/4W F
R155L, R	OB09305A	RM 100K 1/4W F
R156L, R	OB01679A	RK 100 1/4W J
R157L, R	OB05936A	RK 10 1/4W J
R158L, R	OB05936A	RK 10 1/4W J
R160	OB01679A	RK 100 1/4W J
R161	OB09653A	RK 100 1/6W J
R162, 163	OB09653A	RK 100 1/6W J
R164, 165	OB09653A	RK 100 1/6W J
R166, 167	OB09653A	RK 100 1/6W J
R168, 169	OB09653A	RK 100 1/6W J
R170	OB09653A	RK 100 1/6W J
R180, 181	OB05776A	RK 1.0M 1/4W J
R182	OB01888A	RK 10K 1/4W J
R182L, R	OB09491A	RM 1.00K 1/4W F
R183L, R	OB09491A	RM 1.00K 1/4W F
R184L, R	OB22799A	RM 113 1/4W F
R185L, R	OB22799A	RM 113 1/4W F
R186L, R	OB22799A	RM 113 1/4W F
R187L, R	OB22799A	RM 113 1/4W F
R190	OB09734A	RK 240K 1/6W J
R201L, R	OB22576A	RM 475 1/4W F
R202L, R	OB22693A	RM 200 1/4W F
R203L, R	OB22576A	RM 475 1/4W F
R204L, R	OB22693A	RM 200 1/4W F
R205L, R	OB09446A	RM 33.2K 1/4W F
R206L, R	OB22576A	RM 475 1/4W F
R207L, R	OB22693A	RM 200 1/4W F
R208L, R	OB22576A	RM 475 1/4W F
R209L, R	OB22693A	RM 200 1/4W F
R210L, R	OB09446A	RM 33.2K 1/4W F
R211L, R	OB22576A	RM 475 1/4W F
R212L, R	OB22693A	RM 200 1/4W F
R213L, R	OB22576A	RM 475 1/4W F
R214L, R	OB22693A	RM 200 1/4W F
R215L, R	OB09446A	RM 33.2K 1/4W F
R216L, R	OB22778A	RM 2.49K 1/4W F
R217L, R	OB22778A	RM 2.49K 1/4W F
R218L, R	OB22804A	RM 590 1/4W F
R219L, R	OB09419A	RM 2.00K 1/4W F
R220L, R	OB22778A	RM 2.49K 1/4W F
R221L, R	OB22772A	RM 2.15K 1/4W F
R222L, R		

Ref. No.	Part No.	Description
VC5000, 5001	OB42014A	C Trimmer 40P
VC5002	OB42014A	C Trimmer 40P
C501	OB41509A	CC 82P 50V J
C502	OB40564A	CE 100u 25V (LN)
C503	OB09290A	CC 0.01u 50V Z
C504	OB09292A	CC 0.10u 50V Z
C505	OB09817A	CE 33u 10V (LN)
C506	OB09290A	CC 0.01u 50V Z
C507	OB09292A	CC 0.10u 50V Z
C508	OB09833A	CE 4.7u 25V (LN)
C509	OB40564A	CE 100u 25V (LN)
C510	OB09290A	CC 0.01u 50V Z
C511	OB09292A	CC 0.10u 50V Z
C512	OB09817A	CE 33u 10V (LN)
C513	OB09290A	CC 0.01u 50V Z
C514	OB09292A	CC 0.10u 50V Z
C515	OB09833A	CE 4.7u 25V (LN)
C516	OB09817A	CE 33u 10V (LN)
C517	OB09290A	CC 0.01u 50V Z
C518	OB09292A	CC 0.10u 50V Z
C519	OB09833A	CE 4.7u 25V (LN)
C520	OB41957A	CC 6800P 50V Z
C521	OB40046A	CE 22u 6.3V
C522	OB41971A	CC 0.10u 50V Z
C523	OB40188A	CE 1u 50V (BP)
C524	OB05887A	CC 15P 50V K
C525	OB41971A	CC 0.10u 50V Z
C526	OB40046A	CE 22u 6.3V
C527	OB41971A	CC 0.10u 50V Z
C528	OB40046A	CE 22u 6.3V
C529	OB40582A	CE 470u 10V
C530	OB40564A	CE 100u 25V (LN)
C533, 534	OB41971A	CC 0.10u 50V Z
C535, 536	OB41971A	CC 0.10u 50V Z
C537, 538	OB41971A	CC 0.10u 50V Z
C539, 540	OB41971A	CC 0.10u 50V Z
C541, 542	OB41971A	CC 0.10u 50V Z
C543, 544	OB41971A	CC 0.10u 50V Z
C545, 546	OB41971A	CC 0.10u 50V Z
C547, 548	OB41971A	CC 0.10u 50V Z
C549, 550	OB41971A	CC 0.10u 50V Z
C551, 552	OB41971A	CC 0.10u 50V Z
C553, 554	OB41971A	CC 0.10u 50V Z
C555, 556	OB41971A	CC 0.10u 50V Z
C557, 558	OB41971A	CC 0.10u 50V Z
C559, 560	OB41971A	CC 0.10u 50V Z
C561, 562	OB41971A	CC 0.10u 50V Z
C563, 564	OB41971A	CC 0.10u 50V Z
C565, 566	OB41971A	CC 0.10u 50V Z
C567, 568	OB41971A	CC 0.10u 50V Z
C569, 570	OB41971A	CC 0.10u 50V Z
C571	OB41971A	CC 0.10u 50V Z
C572	OB40052A	CE 470u 6.3V
C573	OB09292A	CC 0.10u 50V Z
C574	OB40052A	CE 470u 6.3V
C575	OB09292A	CC 0.10u 50V Z
C576, 577	OB40052A	CE 470u 6.3V
C578	OB09292A	CC 0.10u 50V Z
C579	OB40052A	CE 470u 6.3V
C580	OB09292A	CC 0.10u 50V Z
C581	OB40052A	CE 470u 6.3V
C582	OB09292A	CC 0.10u 50V Z
C583, 584	OB40052A	CE 470u 6.3V
C587	OB40599A	CE 33u 16V
C588	OB05905A	CC 5P 50V C
C589	OB41304A	CML 0.33u 50V J
C590	OB01400A	CE 100u 16V
C5000	OB40570A	CE 47u 16V (LN)
C5001	OB41023A	CC 0.022u 25V
C5002	OB09333A	CE 4.7u 50V (LN)
C5003, 5004	OB09127A	CML 3300P 50V K
C5005	OB09221A	CE 1.5u 50V (LN)
C5006	OB40186A	CE 47u 10V (LN)
C5007	OB41023A	CC 0.022u 25V
C5008	OB41975A	CC 10P 50V D
C5009	OB40153A	CE 1u 50V (LN)
C5010, 5011	OB41023A	CC 0.022u 25V
C5012	OB41979A	CC 82P 50V J
C5013	OB41023A	CC 0.022u 25V
C5014	OB40418A	CE 330u 16V (LN)
C5015, 5016	OB41023A	CC 0.022u 25V
C5017	OB40570A	CE 47u 16V (LN)

Ref. No.	Part No.	Description
C5018	OB41023A	CC 0.022u 25V
C5019	OB41976A	CC 33P 50V J
C5020, 5021	OB41971A	CC 0.10u 50V Z
C5022	OB41971A	CC 0.10u 50V Z
C5023	OB40570A	CE 47u 16V (LN)
C5026	OB40178A	CE 0.47u 50V (LN)
C5027, 5028	OB41971A	CC 0.10u 50V Z
C5029	OB41971A	CC 0.10u 50V Z
C5030, 5031	OB41971A	CC 0.10u 50V Z
C5032, 5033	OB41971A	CC 0.10u 50V Z
C5034	OB40570A	CE 47u 16V (LN)
C5035	OB41978A	CC 68P 50V J
C5036	OB40153A	CE 1u 50V (LN)
C5037	OB41971A	CC 0.10u 50V Z
C5038	OB41708A	CC 22P 50V J
C5039	OB41975A	CC 10P 50V J
C5040	OB41708A	CC 22P 50V J
C5041	OB40570A	CE 47u 16V (LN)
C5042	OB41512A	C 10P 50V D
C5043	OB09292A	CC 0.1u 50V Z
S501, 502	OB70146A	Slide SW 2-2
S503	OB70146A	Slide SW 2-2
S504	OB70151A	Toggle Switch [N-1000P Pro.]
TP1, 2	OB81734A	Check Pin
TP3, 4	OB81734A	Check Pin
TP5, 6	OB81734A	Check Pin
TP7, 8	OB81734A	Check Pin
TP9, 10	OB81734A	Check Pin
TP511, 512	OB81734A	Check Pin
OPT501	OB10274A	Tos Link TOTX174
OPT502	OB10273A	Tos Link TORX174
OPT503	OB10274A	Tos Link TOTX174
OPT504, 505	OB10273A	Tos Link TORX174
PJ501, 502	OB81998A	1P Pin Jack
PJ503, 504	OB81998A	1P Pin Jack
PJ505	OB81998A	1P Pin Jack
	OB80219A	Bus Bar A (2)

- Miscellaneous Part -

CN103	OB84005A	DIN Connector P100PX (1)
	OE03030A	M3x6 + Binding (Nickel) (3)
	OE03502A	Spring Washer 2.6mm (Nickel) (2)
	OE03503A	Nut Hex. 2.6mm (Nickel) (2)
	OE03523A	M2.6x10 + Pan (Nickel) (2)
	OE03526A	BT3x6 + Binding (10)
	OH05463C	DAIF Panel 101P [N-1000P] (1)
	OH05592B	DAIF Panel 102P [N-1000P Pro.] (1)
	OJ05953A	P Jack Earth Plate (5)

8. MOUNTING DIAGRAMS

Notes: 1. Mounting diagram shows a dip side view of the printed circuit board.
2. Parts list is shown in Section 7.

8.1. Power Switch P.C.B. Ass'y

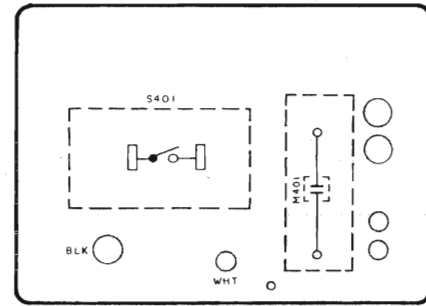

Fig. 8.1

8.2. Output Volume P.C.B. Ass'y

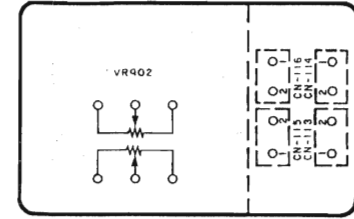

Fig. 8.2

8.3 Input Volume P.C.B. Ass'y

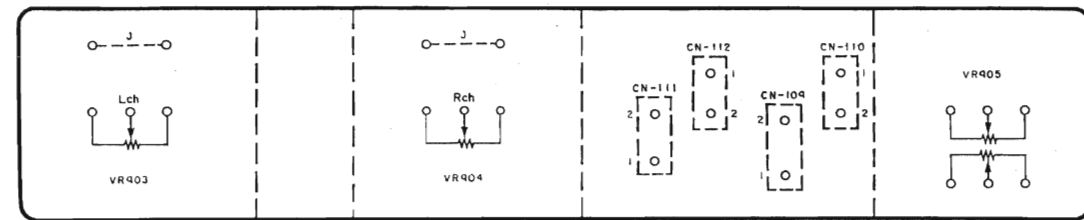

Fig. 8.3

8.4. Monitor Switch P.C.B. Ass'y

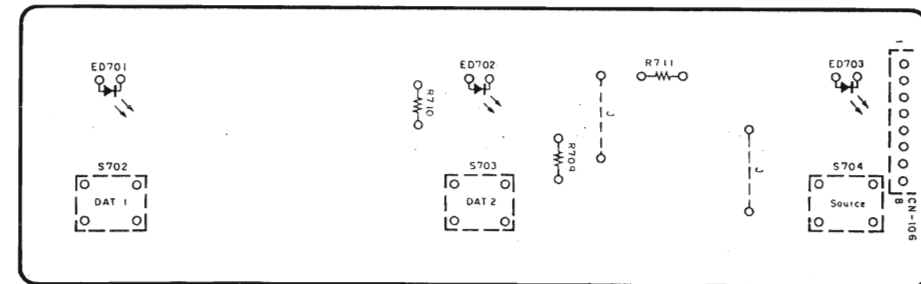

Fig. 8.4

8.5. Headphone P.C.B. Ass'y

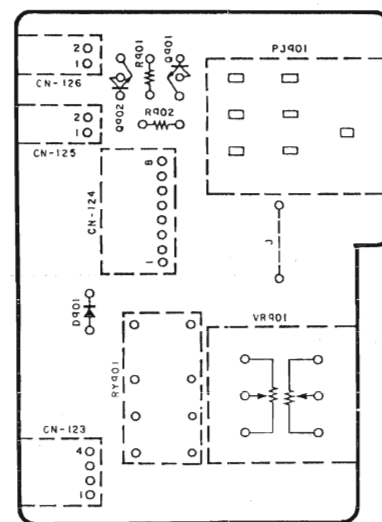

Fig. 8.5

8.6. Analog Power Supply P.C.B. Ass'y

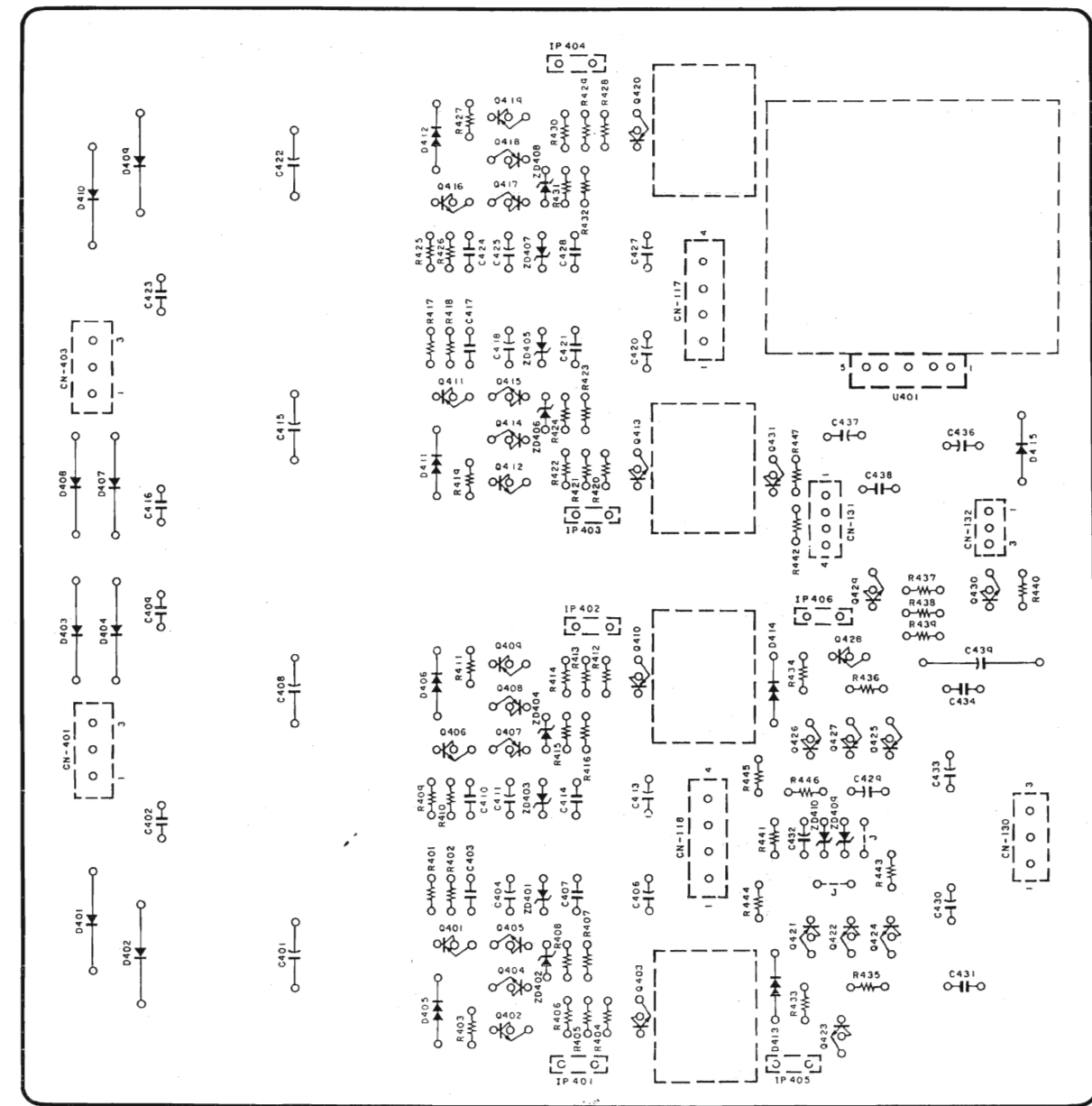

Fig. 8.6

8.7. Digital Power Supply P.C.B. Ass'y

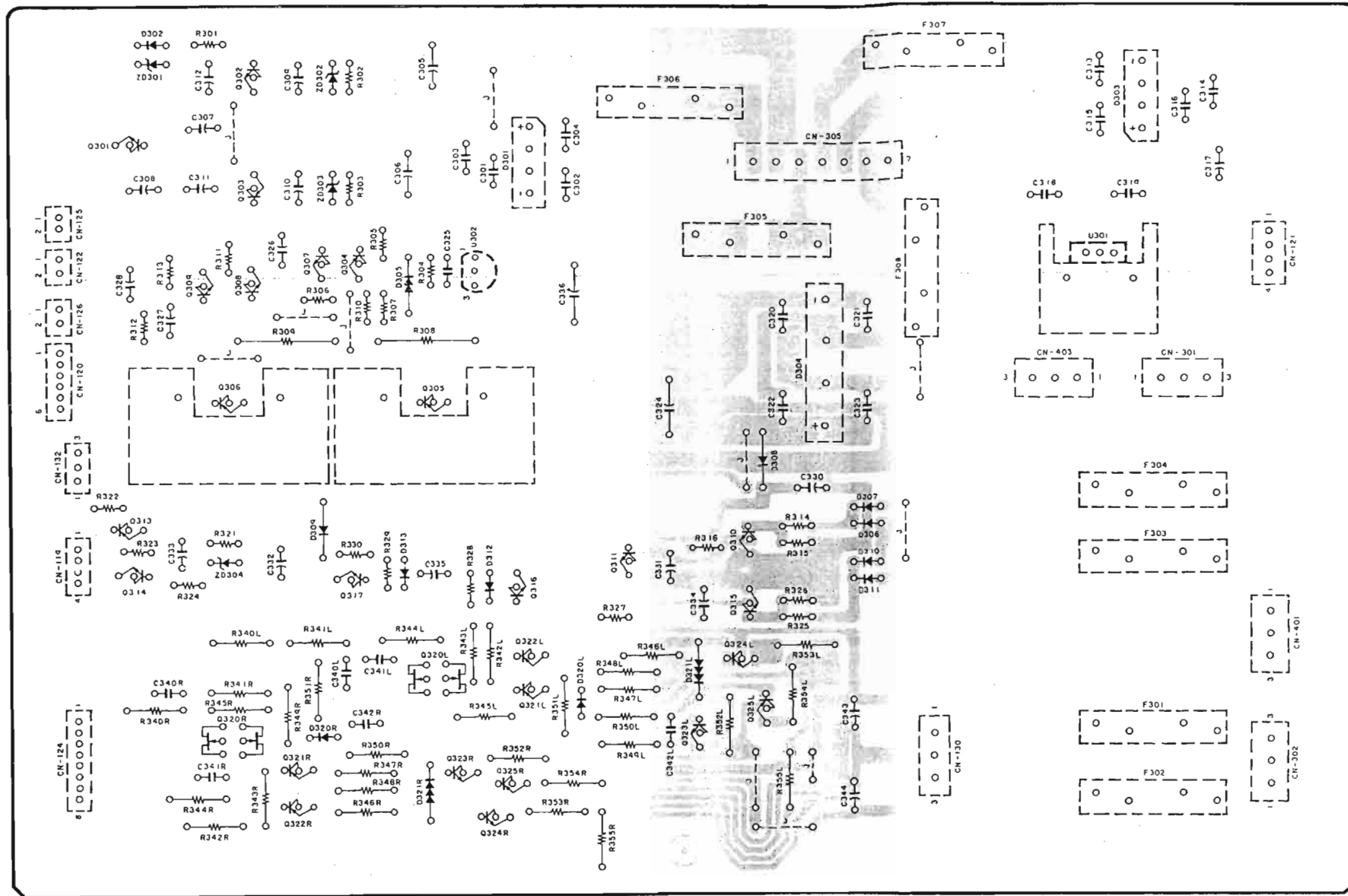

Fig. 8.7

8.8. Display P.C.B. Ass'y

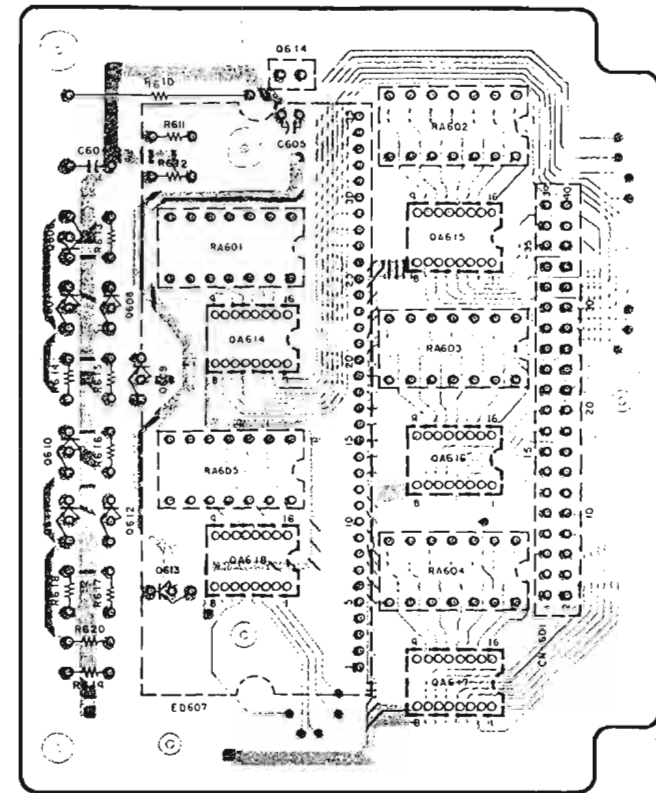

Fig. 8.8

8.9. Function Switch P.C.B. Ass'y

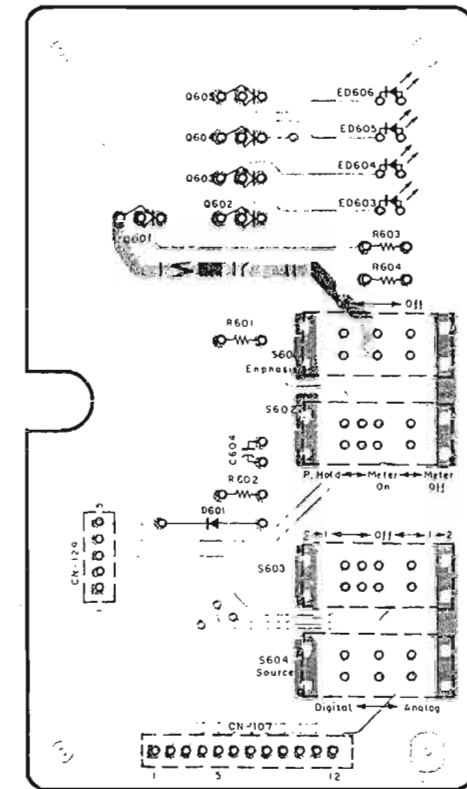
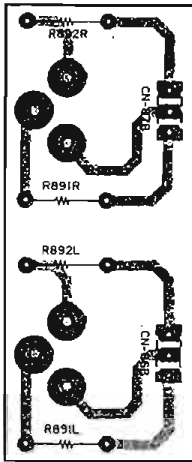
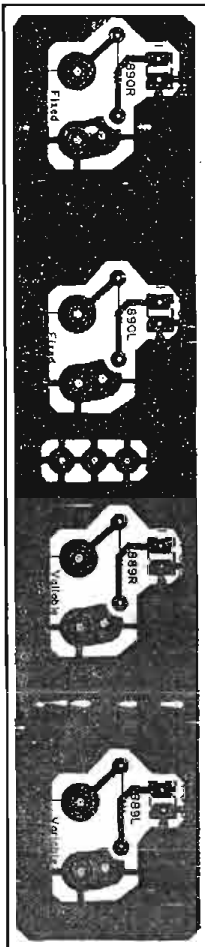

Fig. 8.9



Cannon Connector P.C.B.



Pin Jack P.C.B.

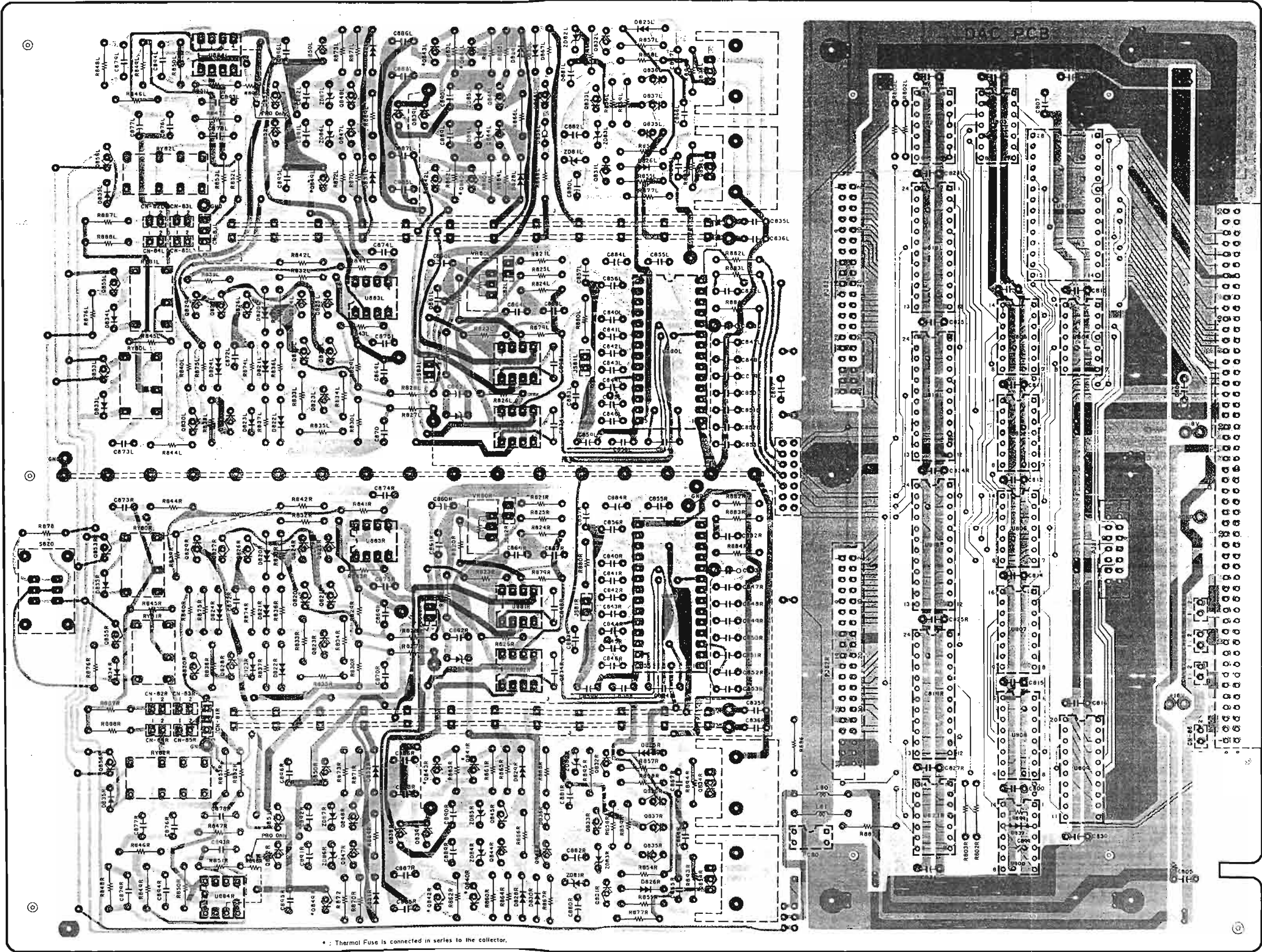

* : Thermal Fuse is connected in series to the collector.

Fig. 8.12.2 DAC Main P.C.B. (DAC P.C.B. Ass'y)

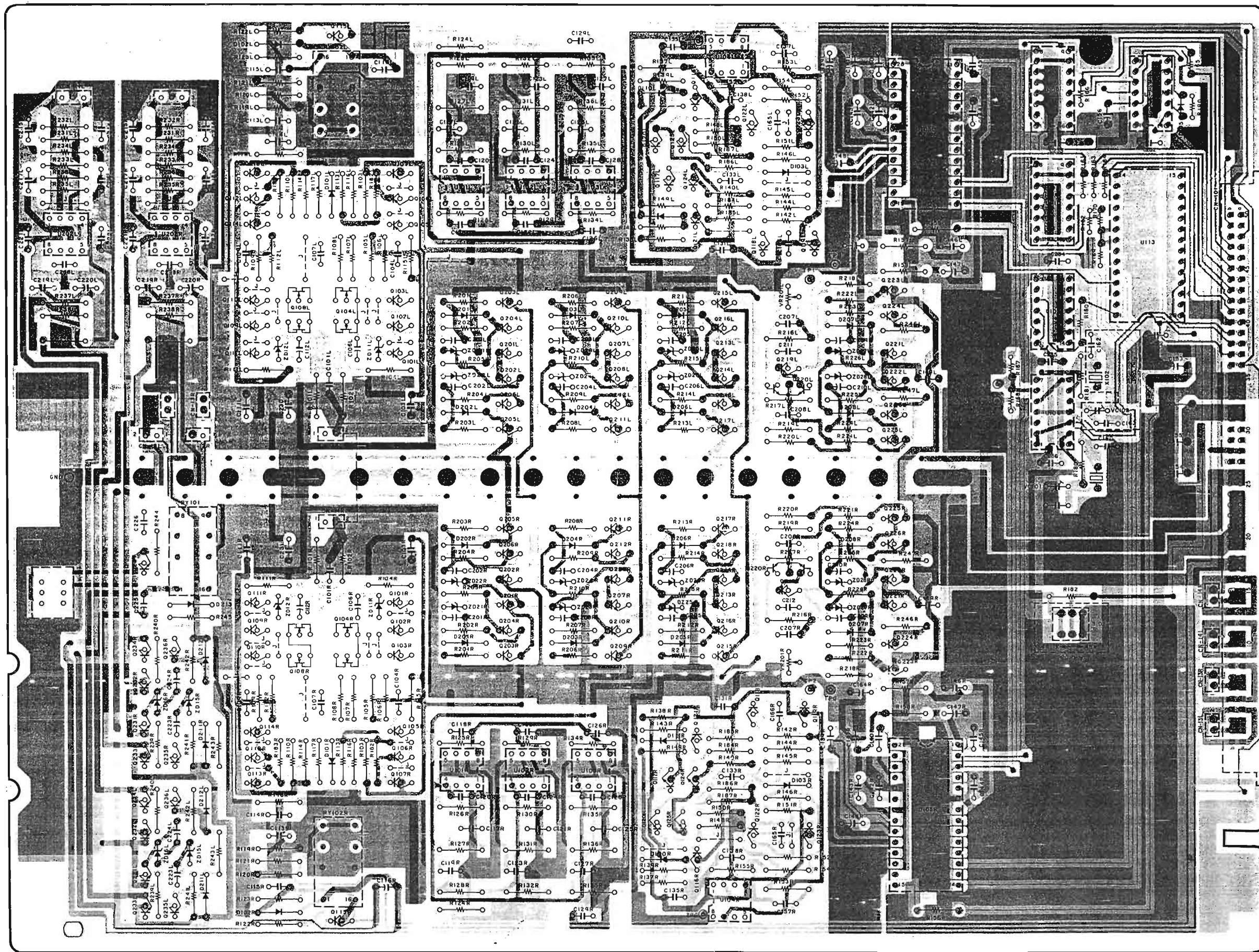

Fig. 8.13

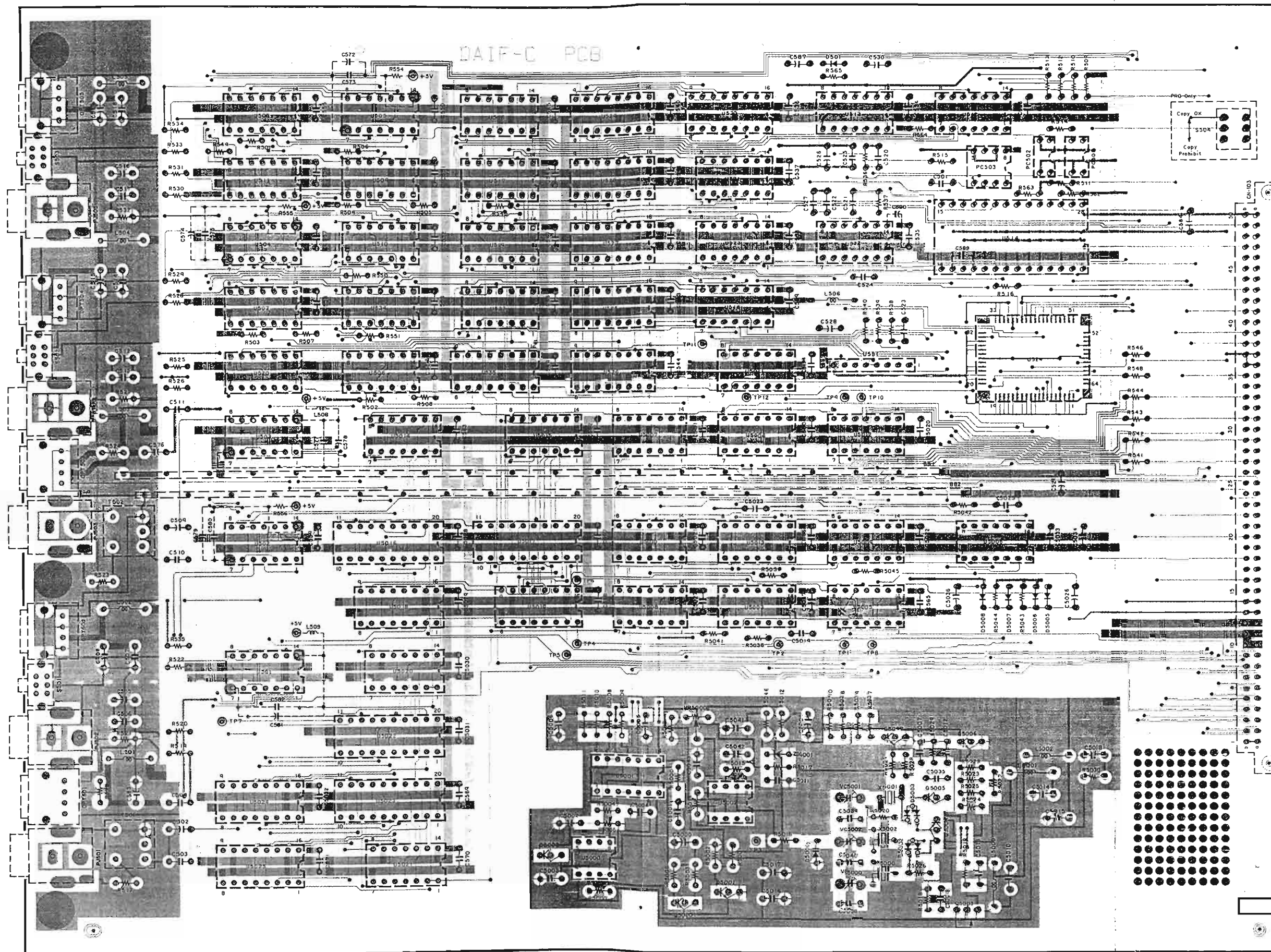

Fig. 8.14

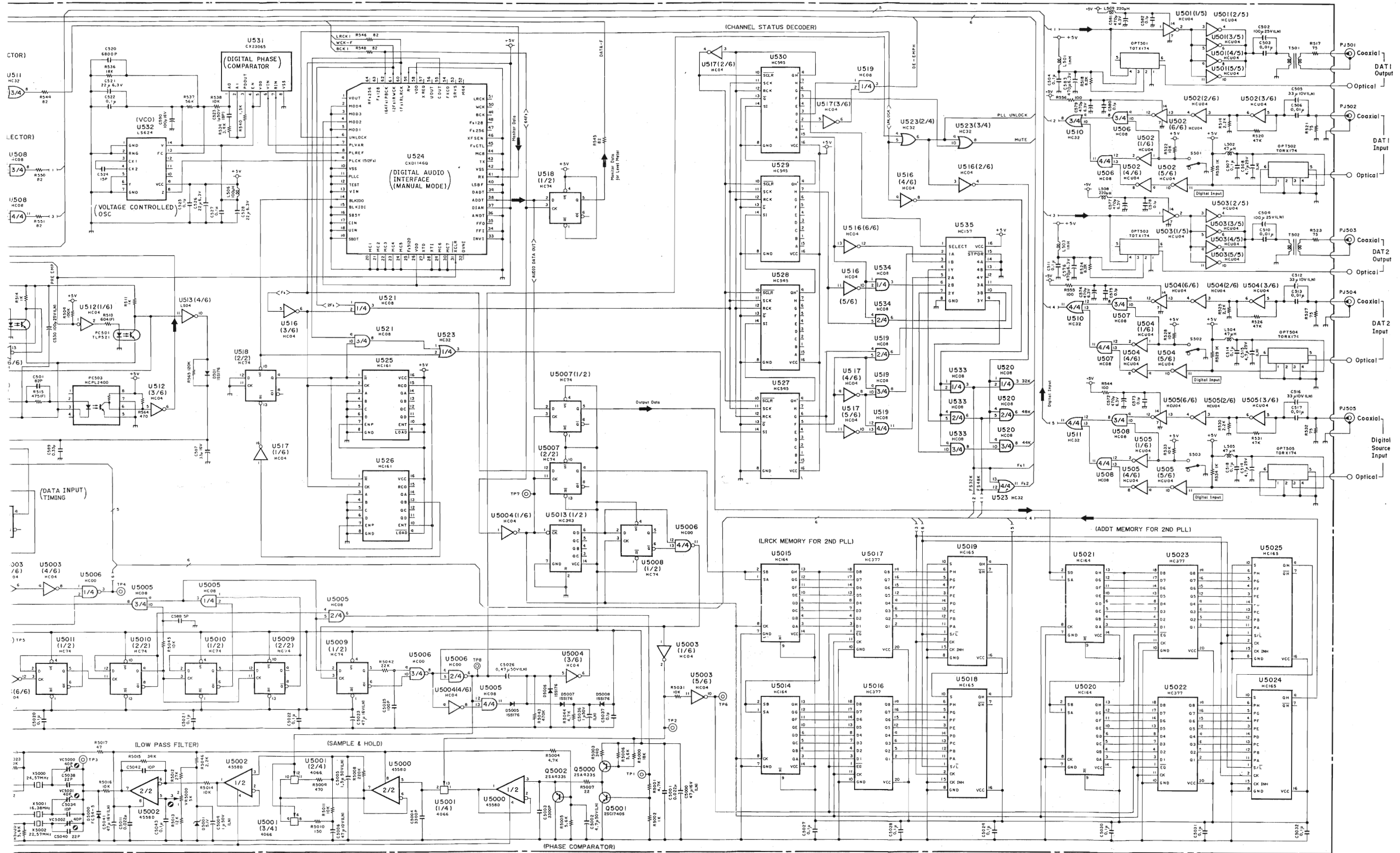

Fig. 9.1 DAIF-C Section

9.2. DAC Section

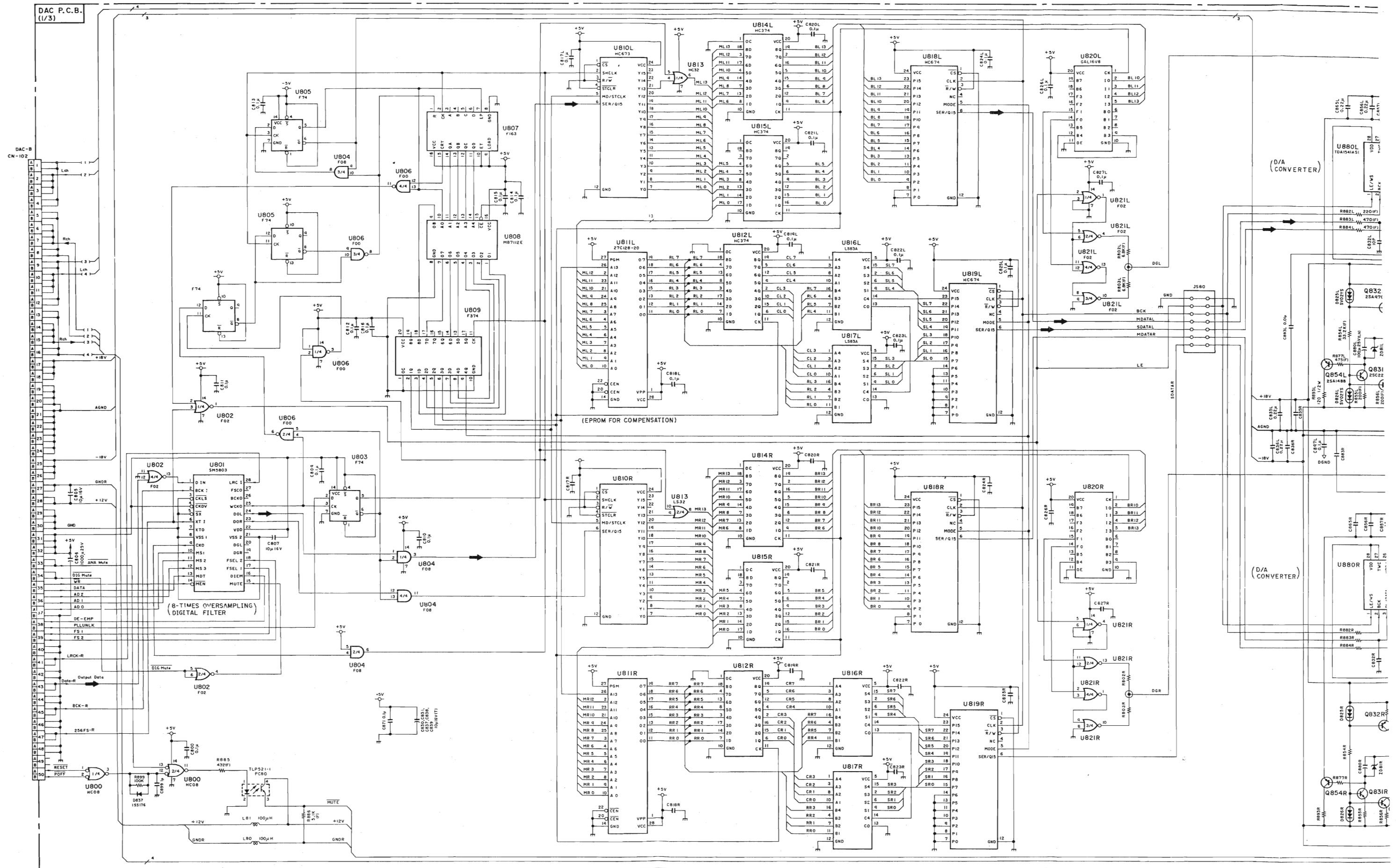

Fig. 9.2 DAC Section

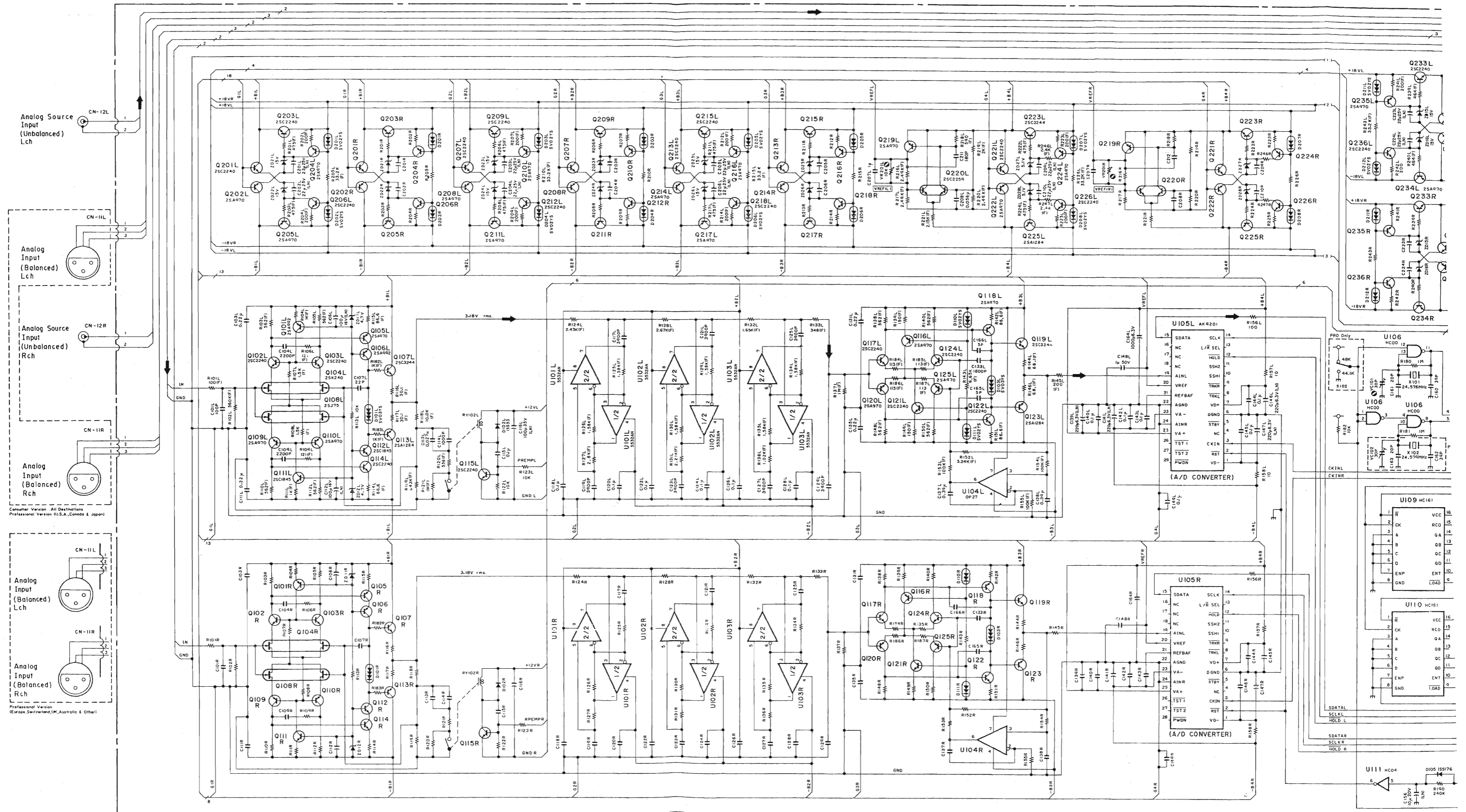

Fig. 9.3 ADC Section

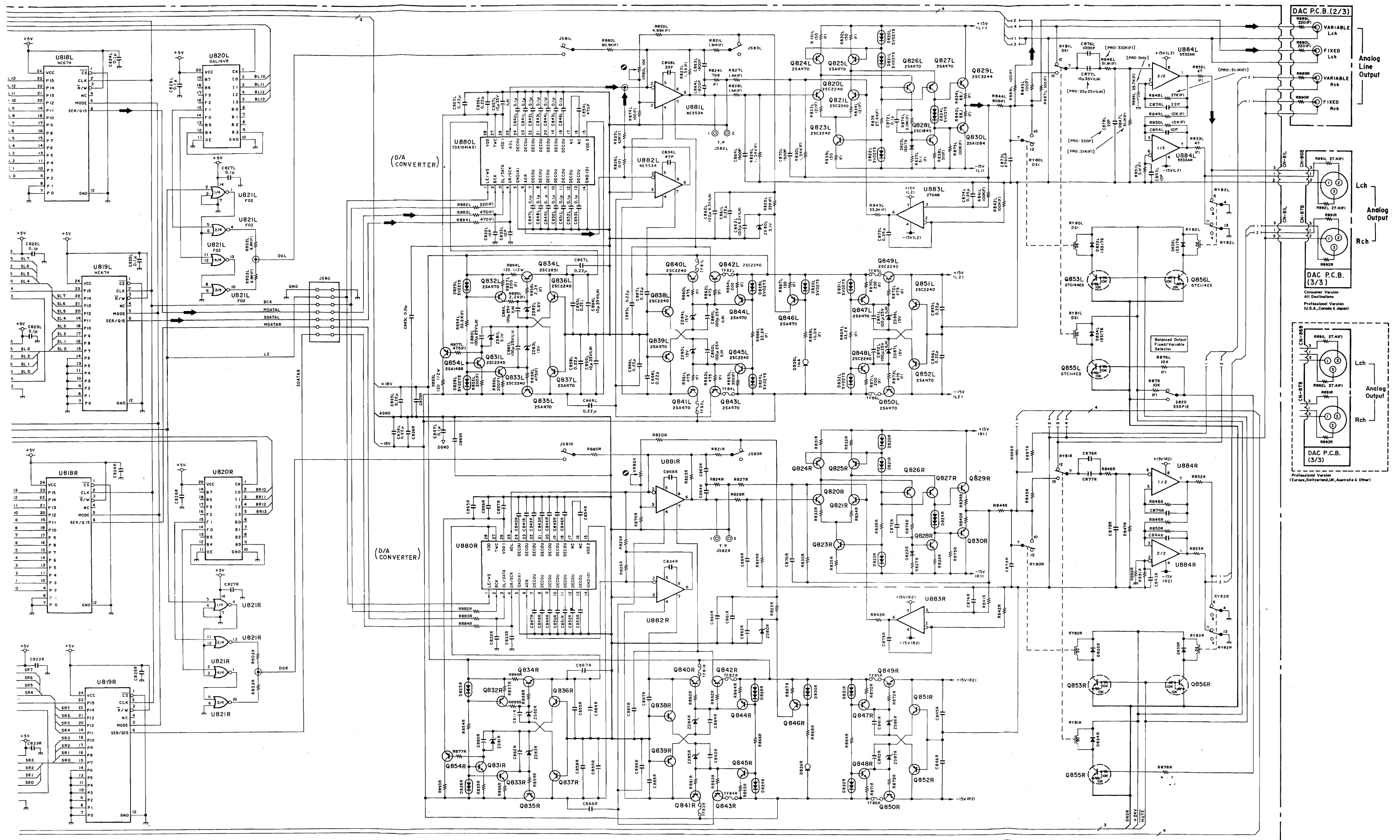

Fig. 9.2 DAC Section

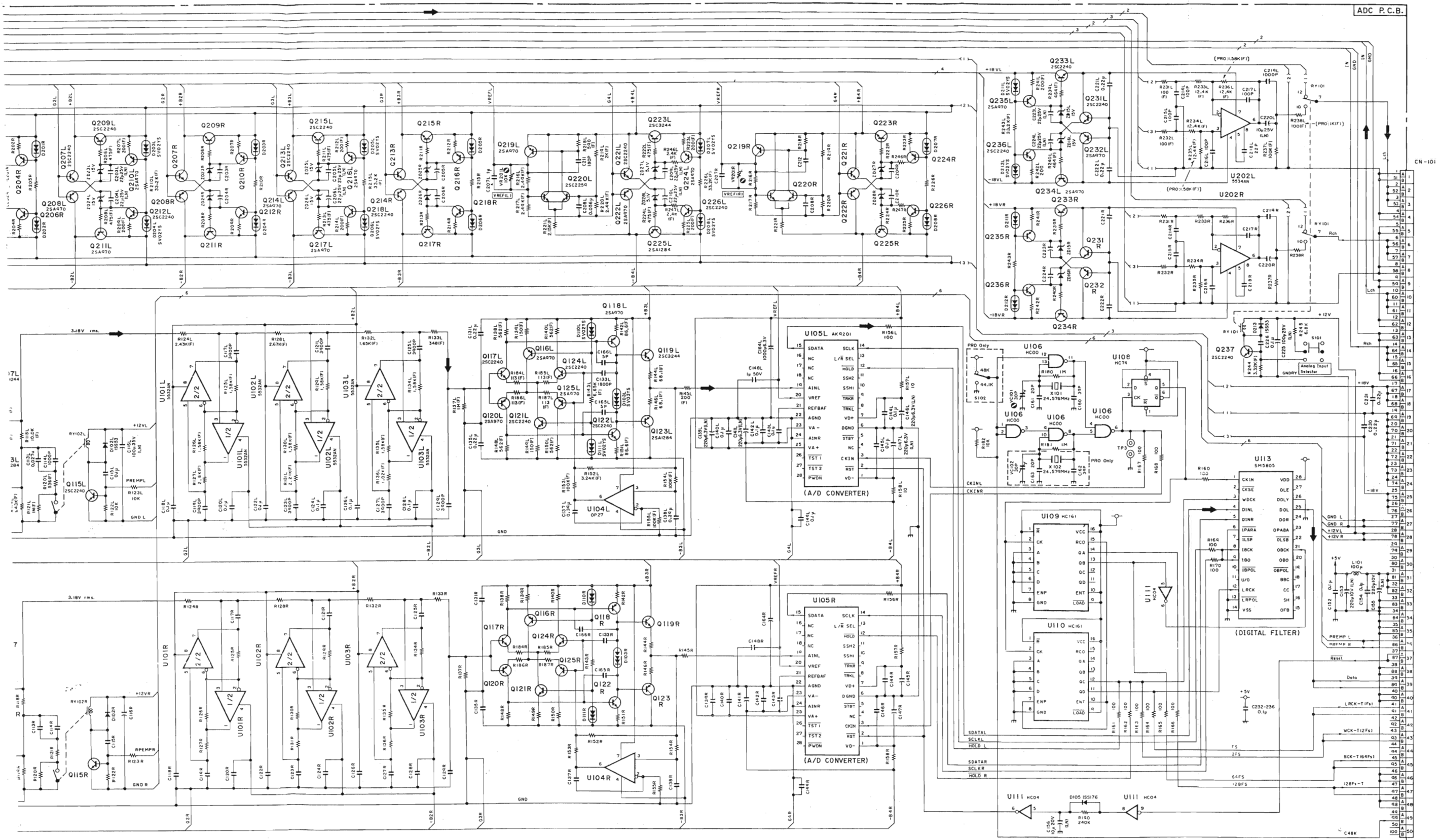

Fig. 9.3 ADC Section

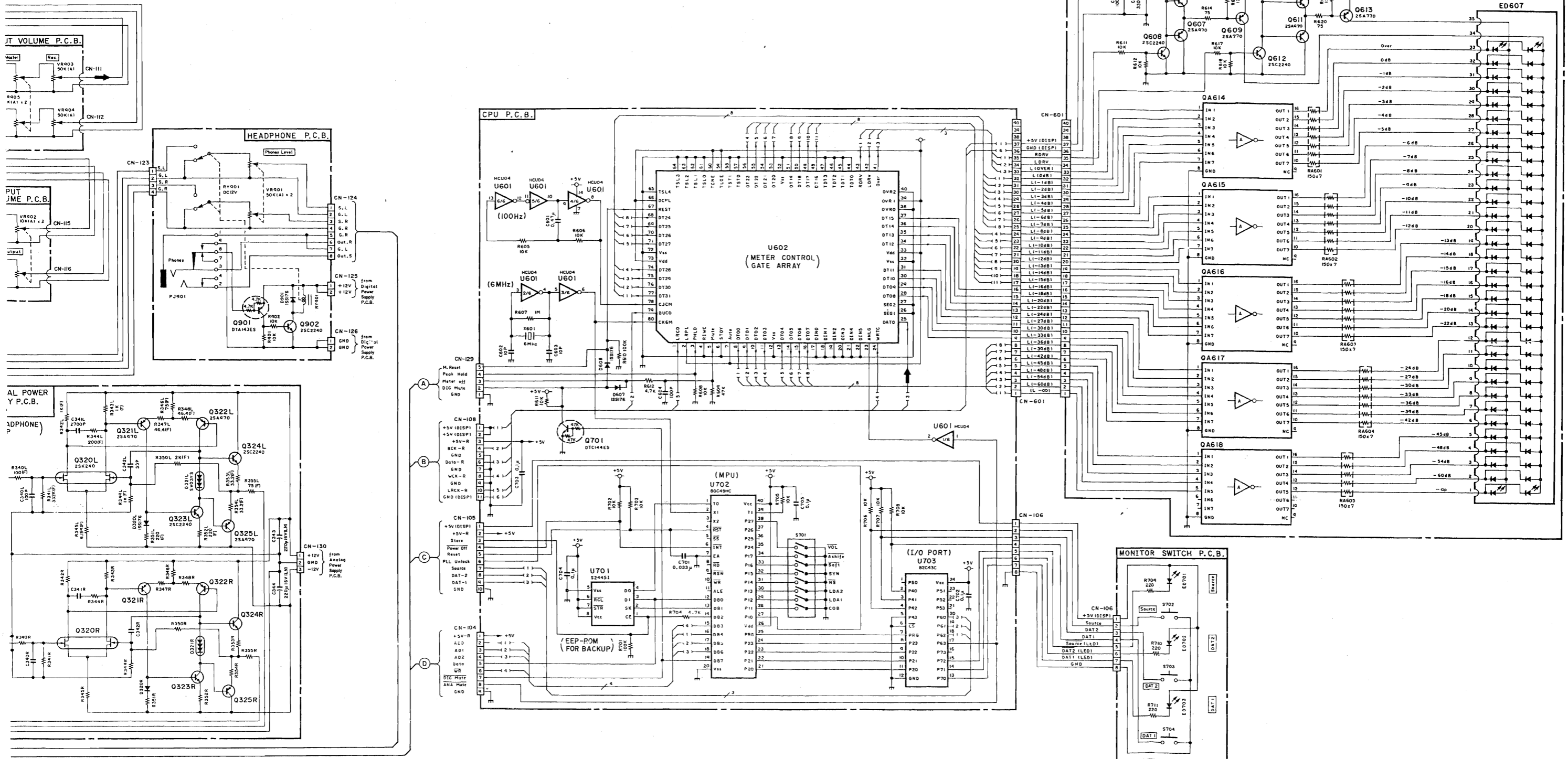

Fig. 9.4 Mother Board/CPU/Display Section

N-1000P
 MOTHER P.C.B.
 CPU P.C.B.
 DISPLAY P.C.B.

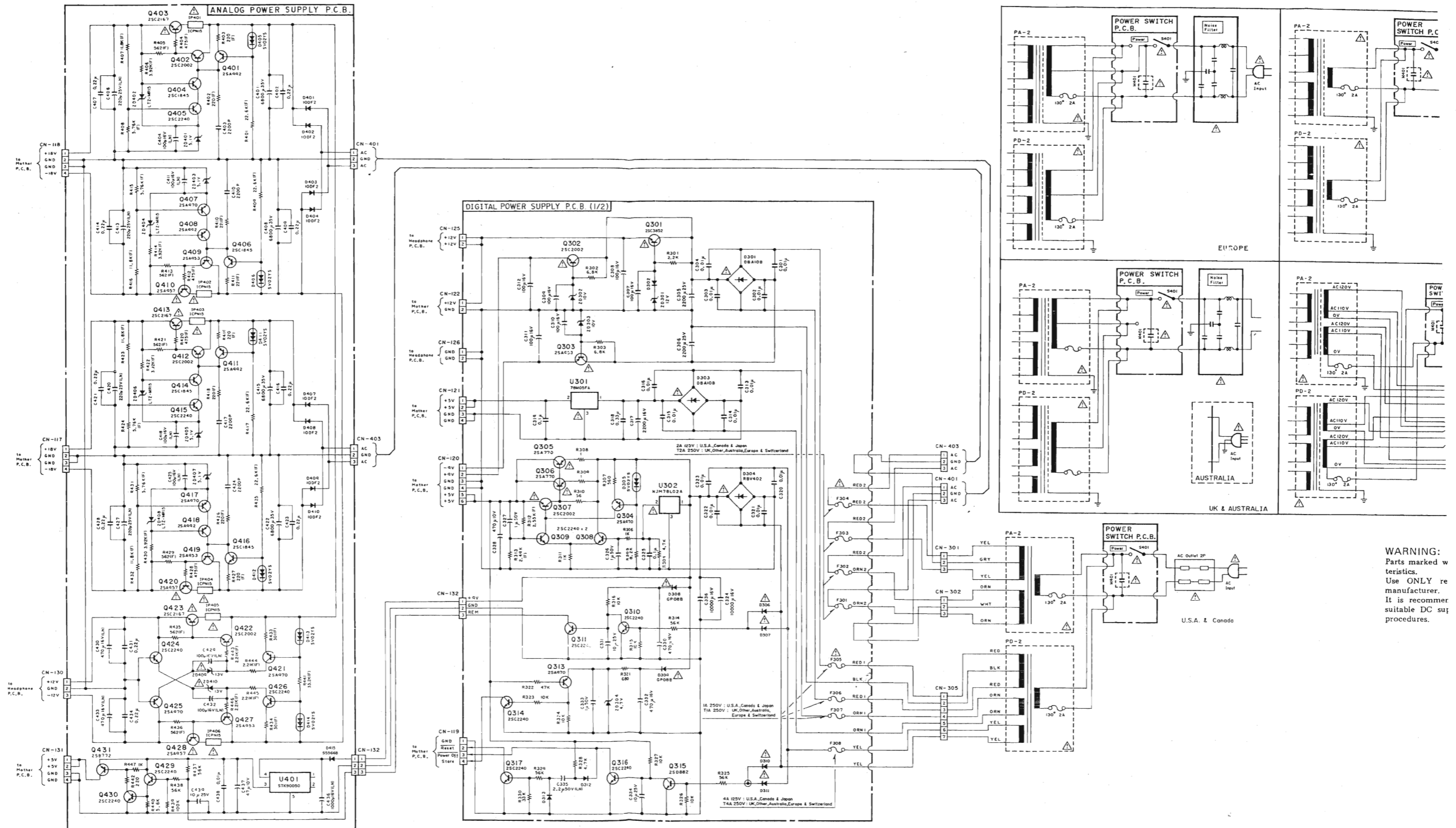

Fig. 9.5 Power Supply Section

WARNING:
Parts marked with asterisks (*) are not standard. Use ONLY re manufacturer. It is recommender suitable DC supply procedures.

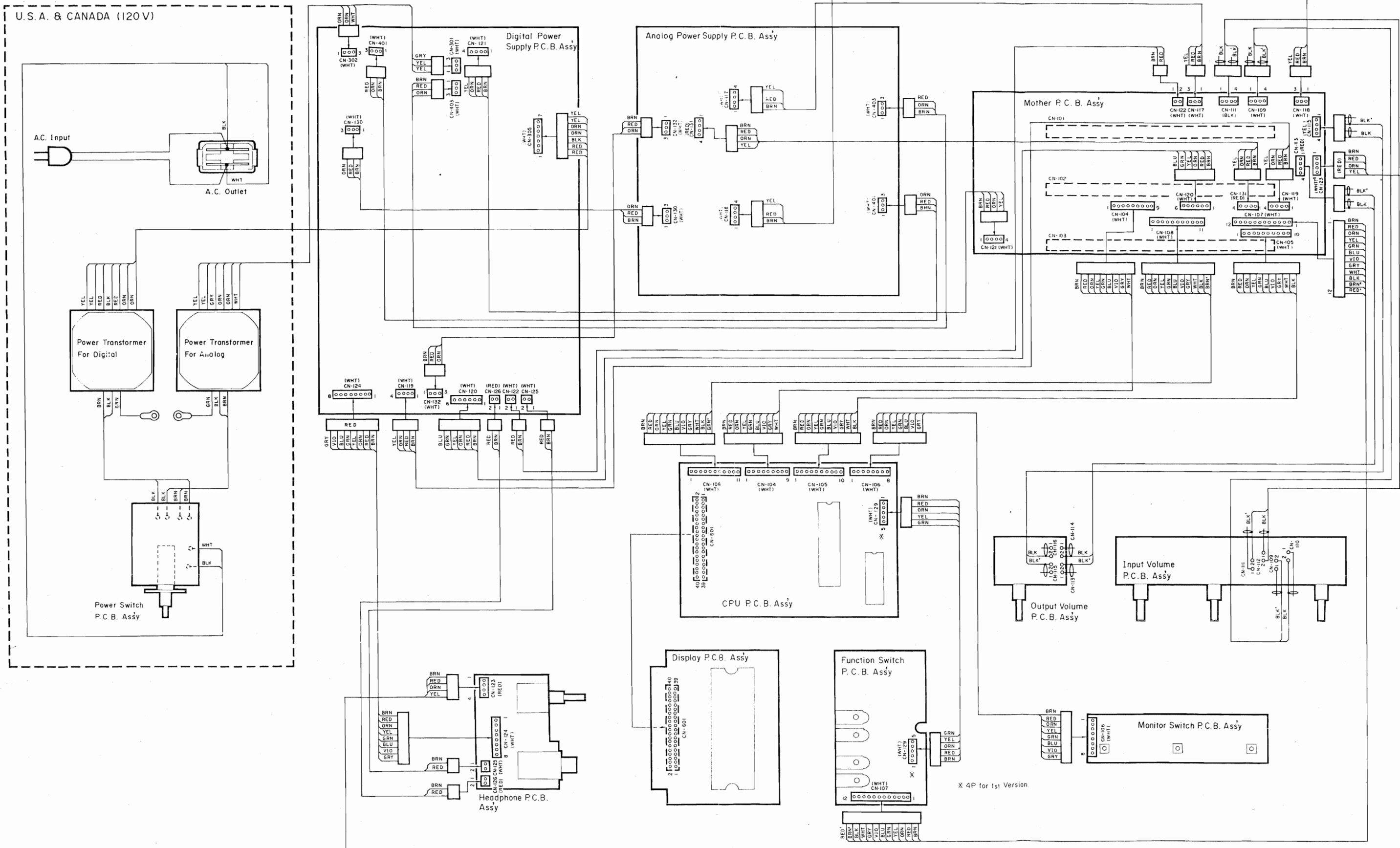
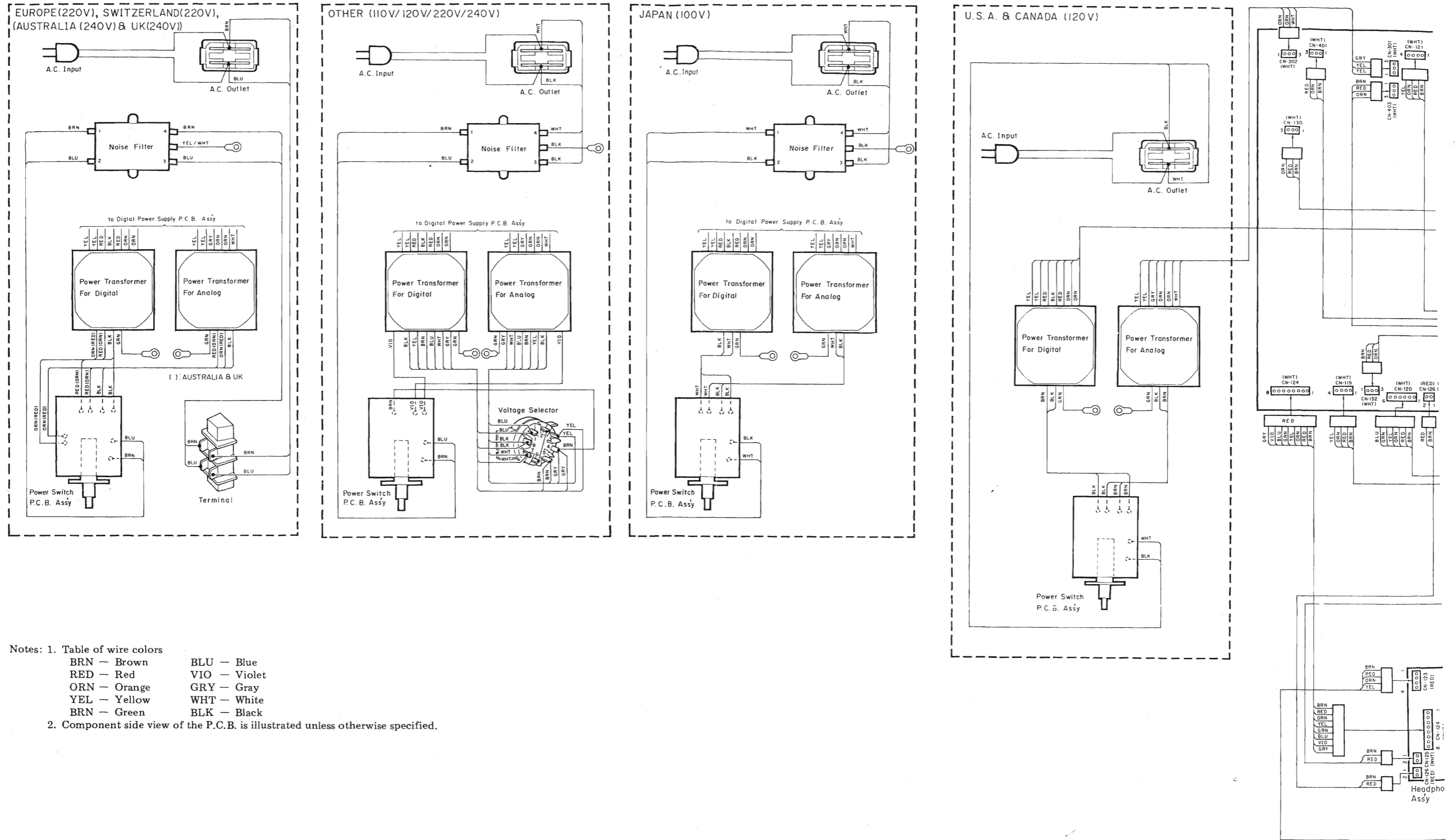

Fig. 10

10. WIRING DIAGRAM



- Notes: 1. Table of wire colors
- | | |
|--------------|--------------|
| BRN — Brown | BLU — Blue |
| RED — Red | VIO — Violet |
| ORN — Orange | GRY — Gray |
| YEL — Yellow | WHT — White |
| BRN — Green | BLK — Black |
2. Component side view of the P.C.B. is illustrated unless otherwise specified.

Fig. 10

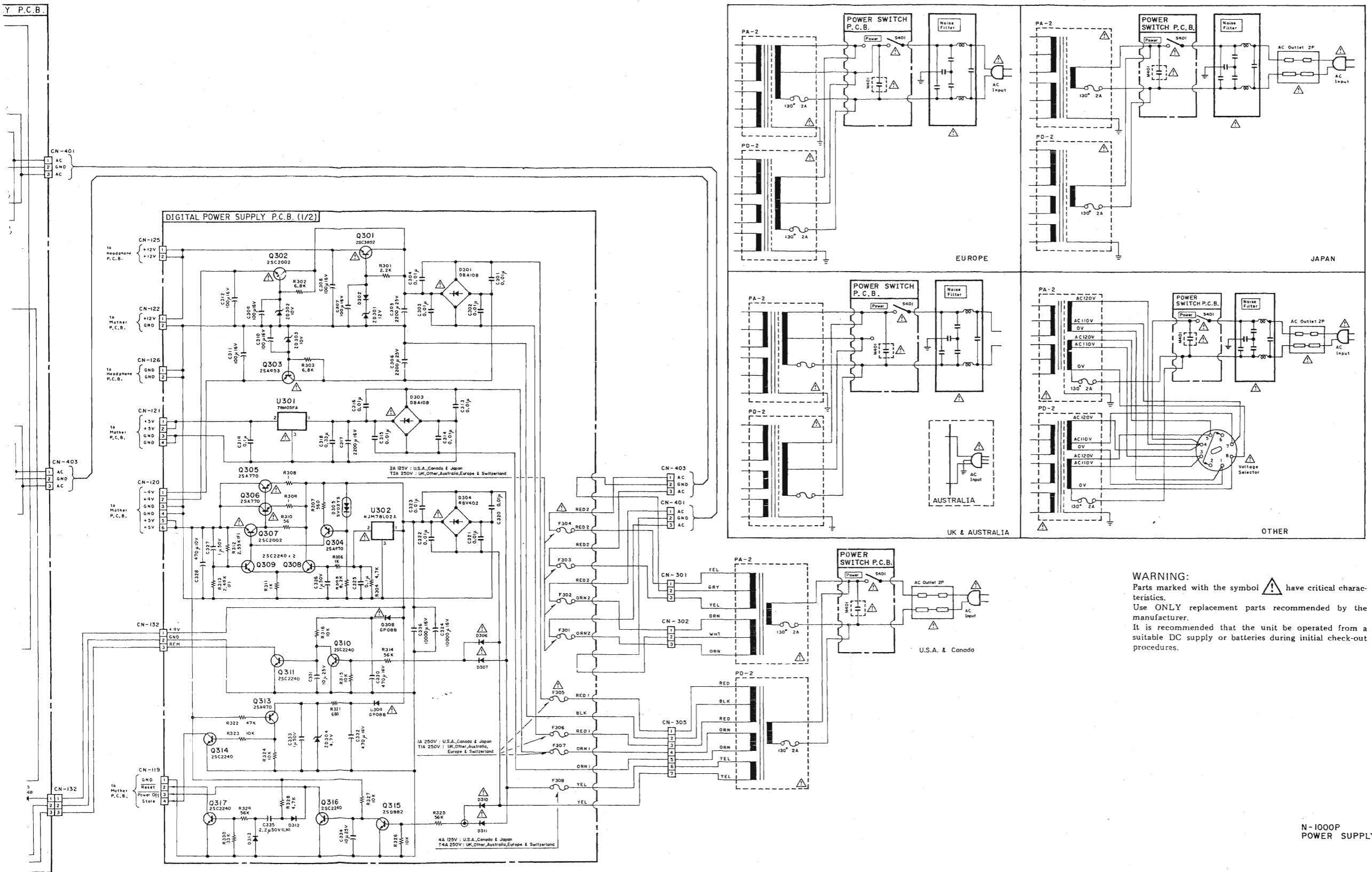

Fig. 9.5 Power Supply Section

N-1000P
POWER SUPPLY P.C.B.

11. SPECIFICATIONS

(D/A Converter)

System	20-bit calibrated D/A converter with 20-bit 8-times oversampling digital filter
Sampling Frequencies	48/44.1/32 kHz
Frequency Response	5 — 20,000 Hz ± 0.5 dB*
Signal-to-Noise Ratio	Better than 106 dB*
Dynamic Range	Better than 100 dB*
Total Harmonic Distortion	0.0005% (1 kHz)*
Total Harmonic Distortion + Noise	0.0015% (1 kHz)*
Channel Separation	Better than 106 dB*

*: with 44.1 kHz sampling frequency

(A/D Converter)

System	16-bit A/D converter with auto calibration and 16-bit dual oversampling digital filter
Sampling Frequency	48 kHz
Frequency Response	5 — 22,000 Hz ± 0.5 dB**
Signal-to-Noise Ratio	Better than 95 dB**
Dynamic Range	Better than 95 dB**
Total Harmonic Distortion	0.001% (1 kHz)**
Total Harmonic Distortion + Noise	0.003% (1 kHz)**
Channel Separation	Better than 85 dB**

** : with 48 kHz sampling frequency, after A/D and D/A conversion

(Input/Output)

Digital Input	75-ohm coaxial/optical (switchable) $\times 3$
Digital Output	75-ohm coaxial/optical (parallel) $\times 2$
Line Input	
(Balanced)	50 mV (–18 dB, Rec Level max.)/ 40 kohms
(Unbalanced)	50 mV (–18 dB, Rec Level max.)/ 25 kohms
Line Output	
(Balanced)	Fixed: 2 V (0 dB)/100 ohms Variable: 2 V (0 dB, output Level max.)/100 ohms
(Unbalanced)	Fixed: 2 V (0 dB)/1 kohm Variable: 2 V (0 dB, Output Level max.)/1 kohm

(General)

Headphone Output	100 mW (0 dB, Phones Level max.)/ 75 ohms
Power Requirements	120, 220, 240 or 110/120/220/240 V AC, 50/60 Hz (According to country of sale)
Power Consumption	70 W max.
Dimensions (excluding protruding parts and feet)	435 (W) \times 133 (H) \times 370 (D) mm 17-1/8 (W) \times 5-1/4 (H) \times 14-9/16 (D) inches
Approximate Weight	17.5 kg, 38 lbs. 9 oz.

• Specifications and design are subject to change for further improvement without notice.