

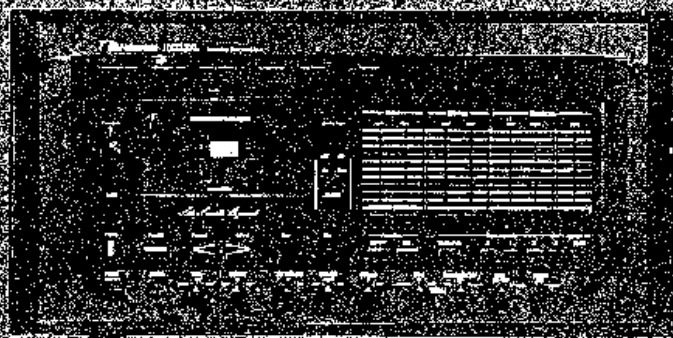

Service Manual

Nakamichi 1000ZXL

Computing Cassette Deck



CONTENTS

1. General	3
2. Removal Procedures	5
2. 1. Cabinet Ass'y	5
2. 2. Cassette Case Cover Ass'y and Azimuth Alignment Cover Ass'y	5
2. 3. Front Panel Ass'y	5
2. 4. Mechanism Ass'y	5
2. 5. CPU P.C.B. Ass'y	5
2. 6. RAMM P.C.B. Ass'y	5
2. 7. Record Eq. Amp. Ass'y, Detector P.C.B. Ass'y, Record Dolby NR P.C.B. Ass'y and Playback Amp. & Dolby NR P.C.B. Ass'y	6
2. 8. Power Switch	6
2. 9. Logic P.C.B. Ass'y	6
2. 10. Main P.C.B. Ass'y	6
2. 11. Rear Panel Ass'y	7
2. 12. Fuse P.C.B. Ass'y and Power Transformer	7
2. 13. Power Supply P.C.B. Ass'y	7
2. 14. FL Indicator Ass'y, Volume Holder & Front Escutcheon B Ass'y, Display House Ass'y, Front Escutcheon A Ass'y, Headphone Jack Holder Ass'y and Front Panel Sub Ass'y	7
2. 15. FL Indicator P.C.B. Ass'y	8
2. 16. Cassette Case Ass'y and Cover Plate Ass'y	9
2. 17. Capstan Motor Ass'y and Flywheel Ass'y	9
2. 18. Sub Mechanism Chassis Ass'y	9
2. 19. Control Motor Ass'y and Reel Motor Ass'y	9
2. 20. Cam Control Volume	9
2. 21. Azimuth Motor Ass'y	9
2. 22. Reel Hub Ass'y and Idler Ass'y	10
2. 23. Cam Drive Gear and Control Cam	10
2. 24. Counter Pulse Generator P.C.B. Ass'y	10
2. 25. Head Mount Base Ass'y	11
2. 26. Pressure Roller Ass'y and Erase Head	11
2. 27. Playback Head Ass'y and Record Head Ass'y	11
2. 28. Battery	11
3. Measurement and Maintenance Instruments	12
3. 1. Measurement Instruments	12
3. 2. Maintenance Instruments	12
4. Mechanical Adjustment	14
4. 1. Mechanism Control Cam Adjustment	14
4. 2. Reel Motor Speed Adjustment in Play Mode	15
4. 3. RAMM Mode Adjustment	15
4. 4. Record Head and Playback Head Tilt Adjustment	17
4. 5. Head Base Stroke Adjustment	19
4. 6. Tape Guides Adjustment and Erase Head Stroke Adjustment	20
4. 7. Erase Head Height and Tilt Adjustment	21
4. 8. Back Tension Adjustment	22
4. 9. Playback Head and Record Head Height Adjustment and Azimuth Alignment	23
4. 10. Record Head Stroke Adjustment	25
4. 11. Tape Travelling Adjustment	26
4. 12. Flywheel Holder Adjustment	26
4. 13. Tape Speed Adjustment	26
4. 14. Lubrication	26
5. Parts Location for Electrical Adjustment	27
6. Electrical Adjustments and Measurements	28
6. 1. Introduction	28
6. 2. Adjustment and Measurement Instructions	29
6. 3. Frequency Response Adjustment	35

6. 4.	Dolby NR Circuit Check	39
7.	Mounting Diagrams and Parts List	40
7. 1.	Fuse P.C.B. Ass'y	40
7. 2.	Power Supply P.C.B. Ass'y	42
7. 3.	Pin Jack P.C.B. Ass'y	43
7. 4.	MIC Jack P.C.B. Ass'y	43
7. 5.	RAMM Control Switch P.C.B. Ass'y	43
7. 6.	Function Switch P.C.B. Ass'y	43
7. 7.	Mechanism Control Switch P.C.B. Ass'y	43
7. 8.	Speed Cal. P.C.B. Ass'y	44
7. 9.	Counter Pulse Generator P.C.B. Ass'y	44
7. 10.	Shut-off P.C.B. Ass'y	44
7. 11.	FL Indicator P.C.B. A Ass'y	44
7. 12.	FL Indicator P.C.B. B Ass'y	45
7. 13.	Detector P.C.B. Ass'y	46
7. 14.	Record Dolby NR P.C.B. Ass'y	47
7. 15.	Record Eq. Amp. P.C.B. Ass'y	48
7. 16.	MIC Amp. and Volume P.C.B. Ass'y	49
7. 17.	Playback Amp. and Dolby NR P.C.B. Ass'y	50
7. 18.	Main P.C.B. Ass'y	53
7. 19.	Logic P.C.B. Ass'y	57
7. 20.	CPU P.C.B. A Ass'y	60
7. 21.	CPU P.C.B. B Ass'y	61
7. 22.	RAMM P.C.B. Ass'y	68
7. 23.	Display P.C.B. Ass'y	69
8.	Mechanism Ass'y and Parts List	70
8. 1.	Synthesis	70
8. 2.	Synthesis Mechanism Ass'y (A01)	70
8. 3.	Cabinet Ass'y (A02)	71
8. 4.	Front Panel Ass'y (B01)	71
8. 5.	FL Indicator Ass'y (B02)	72
8. 6.	Synthesis Mechanism Sub Ass'y (B03)	72
8. 7.	Rear Panel Ass'y (B04)	73
8. 8.	Headphone Jack Ass'y (C01)	73
8. 9.	Display House Ass'y (C02)	73
8. 10.	Front Escutcheon B Ass'y (C03)	73
8. 11.	Front Escutcheon A Ass'y (C04)	75
8. 12.	Mechanism Ass'y 1000ZXL (D01)	76
8. 13.	Chassis Sub Ass'y (D02)	77
8. 14.	Flywheel Holder Ass'y (E01)	77
8. 15.	Sub Mechanism Chassis Ass'y (E02)	78
8. 16.	Main Mechanism Chassis Ass'y (E03)	80
8. 17.	Reel Motor Ass'y (F01)	81
8. 18.	Control Motor Ass'y (F02)	81
8. 19.	Azimuth Alignment Motor Ass'y (F03)	81
8. 20.	Head Mount Base Ass'y (G01)	81
8. 21.	Supply Pressure Roller Ass'y (G02)	81
8. 22.	Take-up Pressure Roller Ass'y (G03)	81
8. 23.	Head Base Ass'y E (G04)	81
8. 24.	Cassette Case Holder L Ass'y (G05)	81
8. 25.	Cassette Case Holder R Ass'y (G06)	81
8. 26.	Auto Shut-off Ass'y (G07)	83
8. 27.	Pneumatic Damper Ass'y (G08)	83
8. 28.	Azimuth Motor Ass'y (H01)	83
8. 29.	P-8L Playback Head Ass'y (I01)	83
8. 30.	R-8L Record Head Ass'y (I02)	83

9.	Timing Chart and Flow Chart	85
9. 1.	Overall Timing Chart	85
9. 2.	Auto Calibration and RAMM Control	85
10.	Eq. Amp. Frequency Response	88
10. 1.	Playback Frequency Response	88
10. 2.	Record Current Frequency Response	88
11.	Block Diagrams	89
11. 1.	Amplifier and A.B.L.E. CPU	89
11. 2.	Mechanism Control and RAMM Control	90
12.	Wiring Diagram	91
13.	Schematic Diagrams	93
13. 1.	Amplifier Section	93
13. 2.	CPU Section	94
13. 3.	Mechanism Control Section	95
13. 4.	IC Block Diagrams	96
14.	Remote Controller RM-300	99
14. 1.	Schematic Diagram	99
14. 2.	Mounting Diagrams and Parts List	100
14. 3.	Mechanism Ass'y and Parts List	101
15.	Specifications	102

1. GENERAL

1.1. Control Functions

The Nakamichi 1000ZXL control functions are shown below:

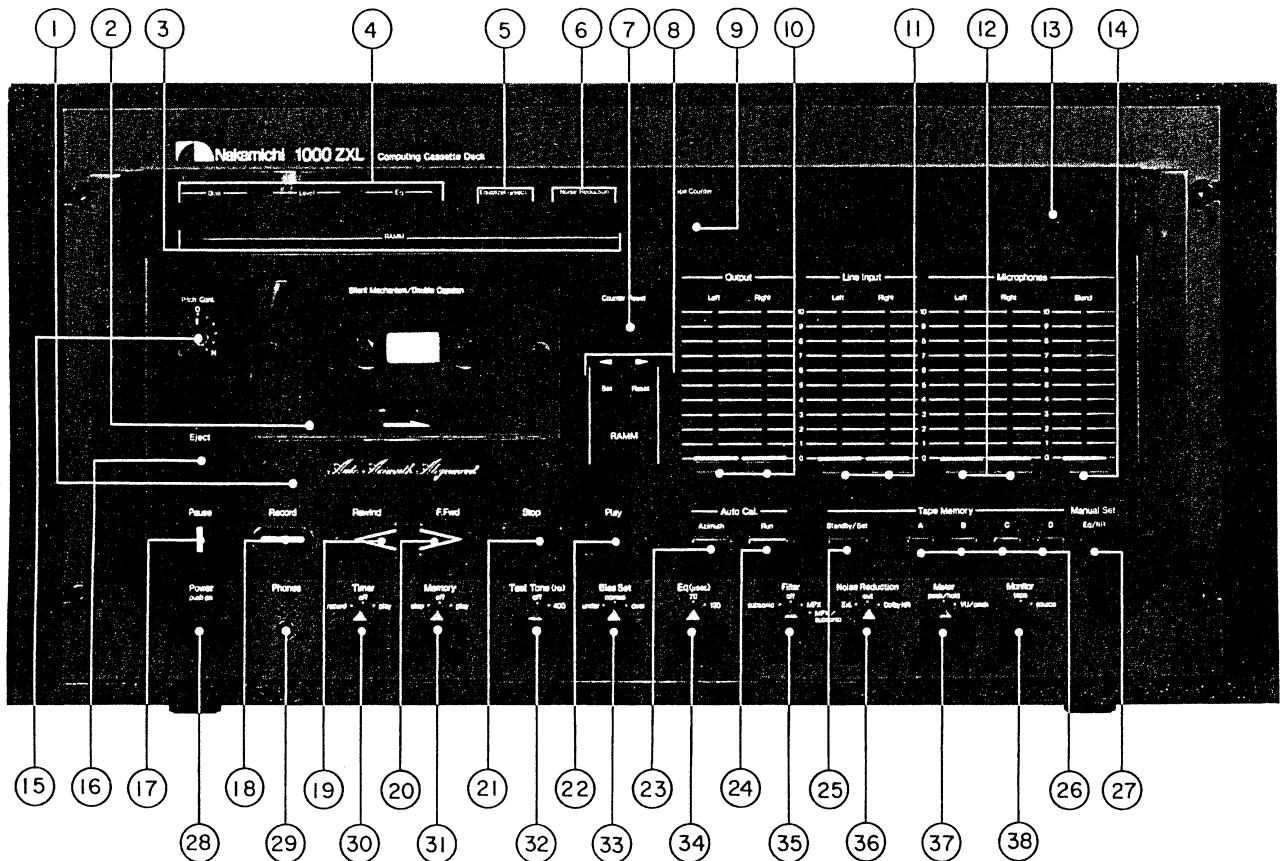

Fig. 1.1 Front View

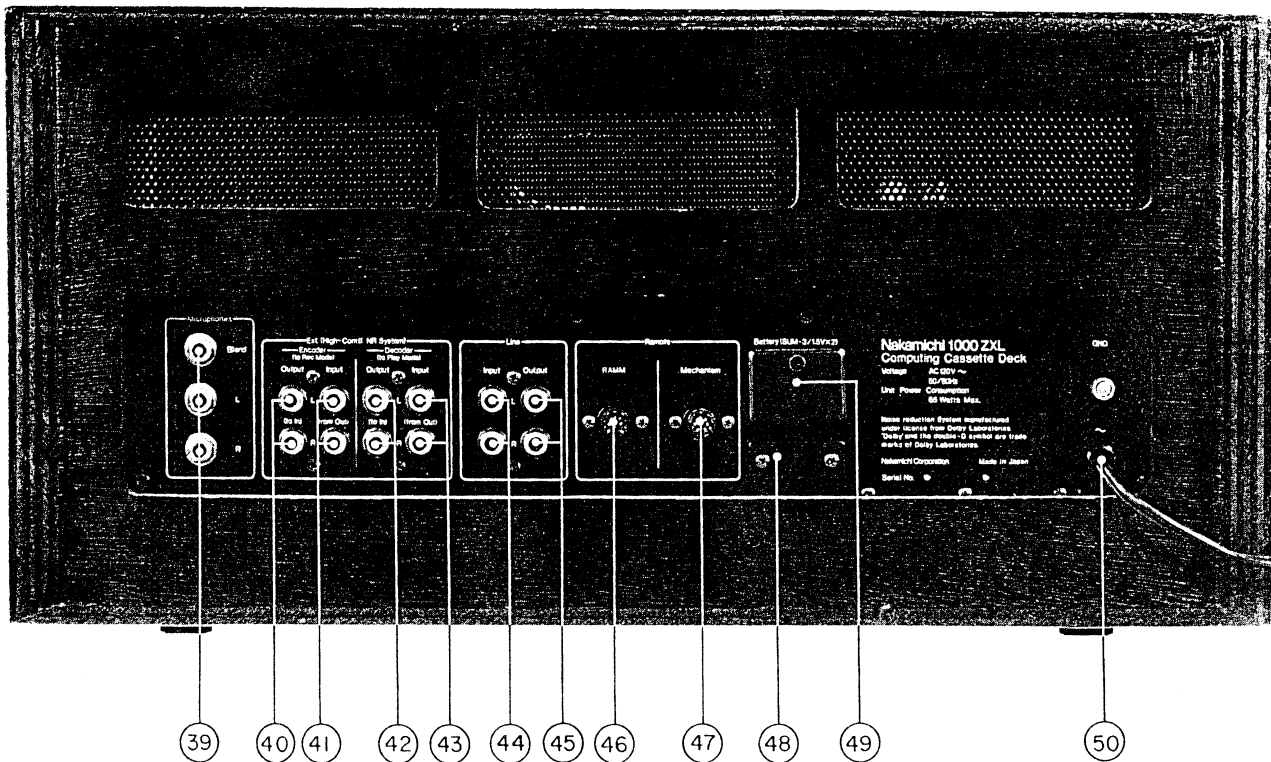

Fig. 1.2 Rear View

- | | |
|--|-------------------------------------|
| 1. Adjustment Screw Cover | 26. Tape Memory Buttons |
| 2. Cassette Holder | 27. Manual Set Button |
| 3. RAMM Indicator Panel | 28. Power Switch |
| 4. Auto Calibration Indicator Panel | 29. Headphone Jack |
| 5. Playback Equalization Indicator Panel | 30. Timer Switch |
| 6. Noise Reduction Indicator Panel | 31. Memory Switch |
| 7. Counter Reset Button | 32. Test Tone Switch |
| 8. RAMM Control Buttons | 33. Bias Set Switch |
| 9. Tape Counter | 34. Playback Equalization Switch |
| 10. Output Level Controls (L, R) | 35. Filter Switch |
| 11. Line Input Level Controls (L, R) | 36. Noise Reduction Switch |
| 12. MIC Level Controls (L, R) | 37. Meter Switch |
| 13. Fluorescent (FL) Level Indicators | 38. Monitor Switch |
| 14. Blend MIC Level Control | 39. Microphone Jacks |
| 15. Pitch Control | 40. Encoder Output Jacks |
| 16. Eject Button | 41. Encoder Input Jacks |
| 17. Pause Button | 42. Decoder Output Jacks |
| 18. Record Button | 43. Decoder Input Jacks |
| 19. Rewind Button | 44. Line Input Jacks |
| 20. Fast-Forward Button | 45. Line Output Jacks |
| 21. Stop Button | 46. RAMM Remote Control Socket |
| 22. Play Button | 47. Transport Remote Control Socket |
| 23. Auto Azimuth Alignment Button | 48. Voltage Selector |
| 24. Auto Calibration Button | 49. Battery Compartment |
| 25. Standby/Set Button | 50. Power Cord |

1.2. Voltage Selector

Voltage selector is installed on the rear panel for Other Version of the Nakamichi 1000ZXL. This voltage selector can select either 120 V or 220-240 V at customer's disposal.

2. REMOVAL PROCEDURES

2.1. Cabinet Ass'y

Refer to Fig. 2.1.

- (1) Remove F01, F02, F03 and F04, then disassemble F05 (Synthesis Mechanism Ass'y) and F06 (Cabinet Ass'y).

2.2. Cassette Case Cover Ass'y and Azimuth Alignment Cover Ass'y

Refer to Fig. 2.2.

- (1) Turn fully counterclockwise two screws which are mounted on the Cassette Case Cover, then disassemble F01 (Cassette Case Cover Ass'y).
- (2) Turn fully counterclockwise two screws which are mounted on the Azimuth Alignment Cover, then disassemble F02 (Azimuth Alignment Cover Ass'y).

2.3. Front Panel Ass'y

Refer to Fig. 2.2.

- (1) Refer to Fig. 2.1. Remove Cabinet Ass'y referring to item 2.1.
- (2) Pull out F03 (Pitch Control Knob) and F04 (Function Switch Knob).
- (3) Remove F05, F06 and F07, then disassemble F08 (CPU P.C.B. Shield Plate).
- (4) Remove F09, then turn F10 (CPU P.C.B. Ass'y) over as an arrow head.
- (5) Remove F11 and F12, then turn F13 (Rear Panel

Ass'y) as an arrow head.

- (6) Disassemble F14 (Front Panel Ass'y including 19 connectors).

2.4. Mechanism Ass'y

Refer to Fig. 2.2.

- (1) Remove Front Panel Ass'y referring to item 2.3.
- (2) Remove F15 and F16, then disassemble F17 (Mechanism Ass'y including 6 connectors).

2.5. CPU P.C.B. Ass'y

Refer to Fig. 2.3.

- (1) Refer to Fig. 2.2. Remove Front Panel Ass'y referring to item 2.3.
- (2) Remove F01 and F02, then disassemble F03 (CPU P.C.B. Shield Plate).
- (3) Remove F04 and F05, then disassemble F06 (CPU P.C.B. Ass'y including 6 connectors).
- (4) Remove F07 (CPU P.C.B. B Ass'y) by releasing the self-interlocking pin of the P.C.B. Supporters, then disassemble F08 (CPU P.C.B. A Ass'y).

2.6. RAMM P.C.B. Ass'y

Refer to Fig. 2.3.

- (1) Remove CPU P.C.B. Ass'y referring to item 2.5.
- (2) Remove F09, F10, F11 and F12 then disassemble F13 (RAMM P.C.B. Ass'y including 12 connectors).

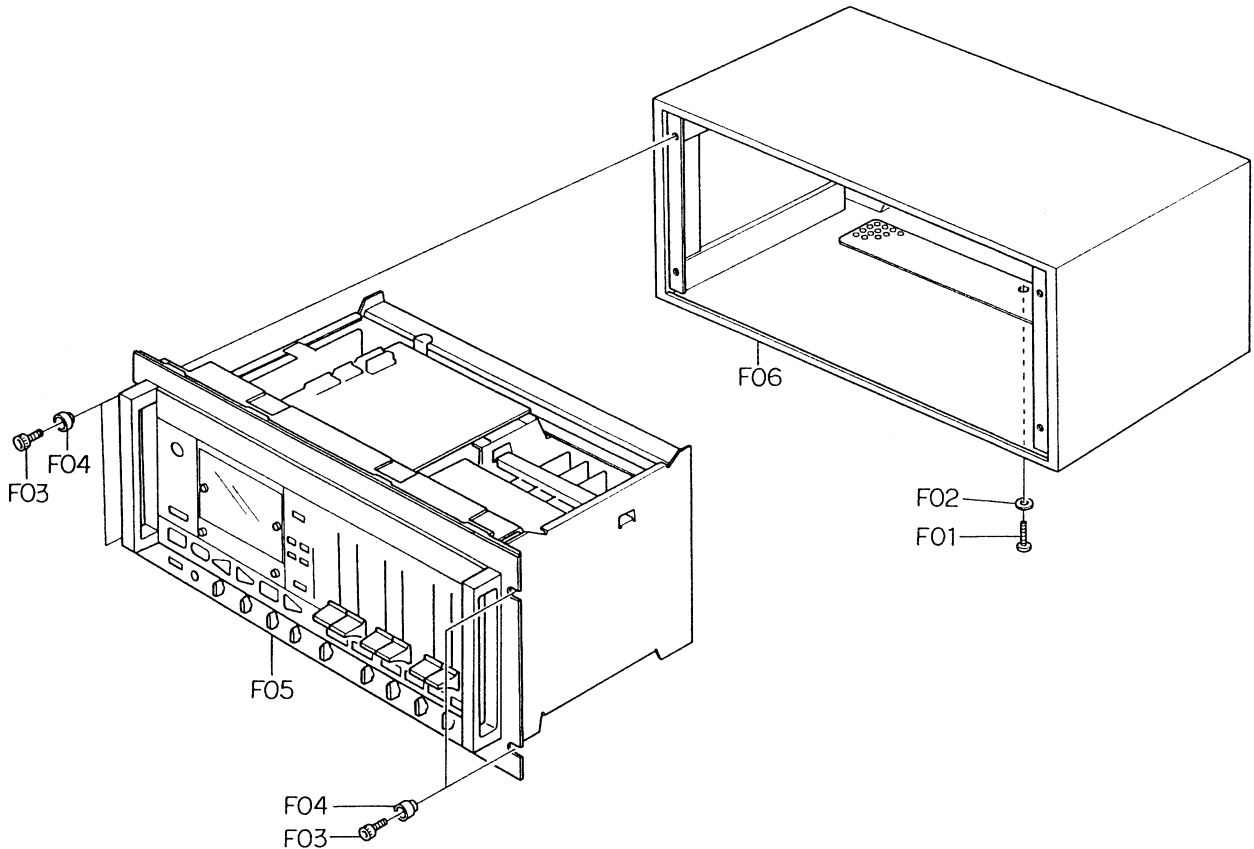

Fig. 2.1

2.7. Record Eq. Amp. Ass'y, Detector P.C.B. Ass'y, Record Dolby NR P.C.B. Ass'y and Playback Amp. & Dolby NR P.C.B. Ass'y

Refer to Fig. 2.3.

- (1) Refer to Fig. 2.1. Remove Cabinet Ass'y referring to item 2.1.
- (2) Remove F14, then disassemble F15 (P.C.B. Holder Ass'y).
- (3) Pull out F16 (Record Eq. Amp. P.C.B. Ass'y), F17 (Detector P.C.B. Ass'y), F18 (Record Dolby NR P.C.B. Ass'y) and F19 (Playback Amp. & Dolby NR P.C.B. Ass'y).

2.8. Power Switch

Refer to Fig. 2.3.

- (1) Refer to Fig. 2.2. Remove Front Panel Ass'y referring to item 2.3.
- (2) Remove F20, then disassemble F21 (Power Switch).

2.9. Logic P.C.B. Ass'y

Refer to Fig. 2.3.

- (1) Refer to Fig. 2.2. Remove Front Panel Ass'y referring to item 2.3.
- (2) Remove F22, F23 and F24, then disassemble F25 (Logic P.C.B. Ass'y including 6 connectors and wires connected by soldering).

2.10. Main P.C.B. Ass'y

Refer to Fig. 2.3.

- (1) Remove Front Panel Ass'y referring to item 2.3.
- (2) Remove F16, F27 and F28 and F29, then disassemble F30 (Main P.C.B. Shield Plate).
- (3) Remove F31, then disassemble F32 (Main P.C.B. Ass'y including 2 connectors and wires connected by wrapping).

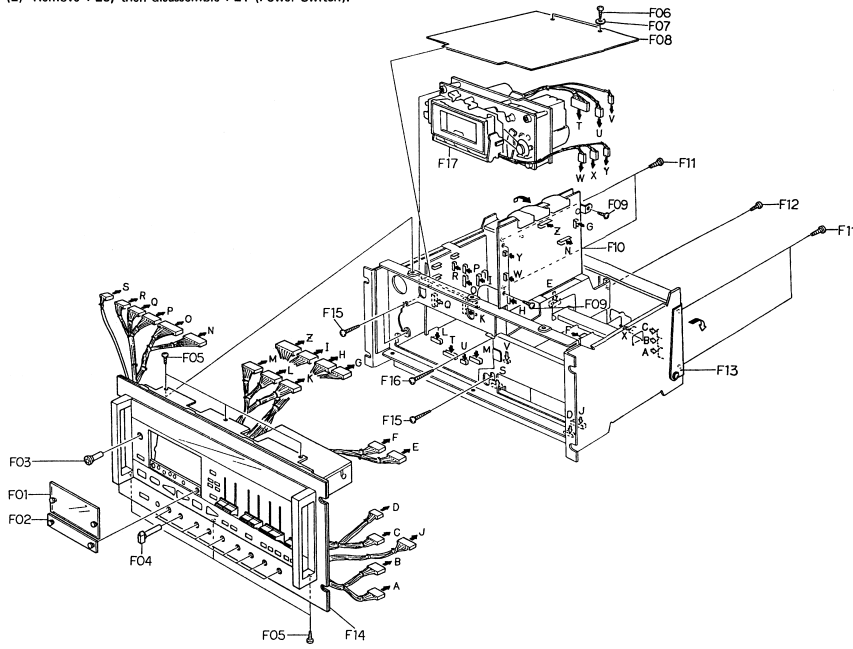

Fig. 2.2

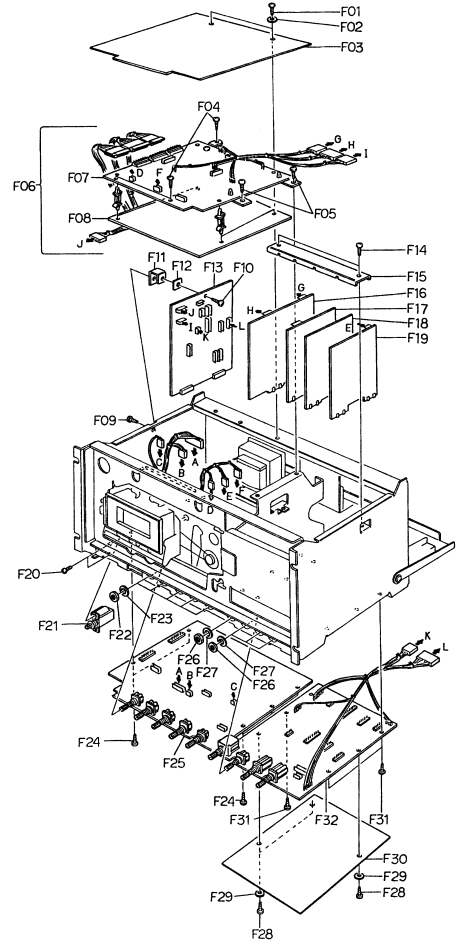

Fig. 2.3

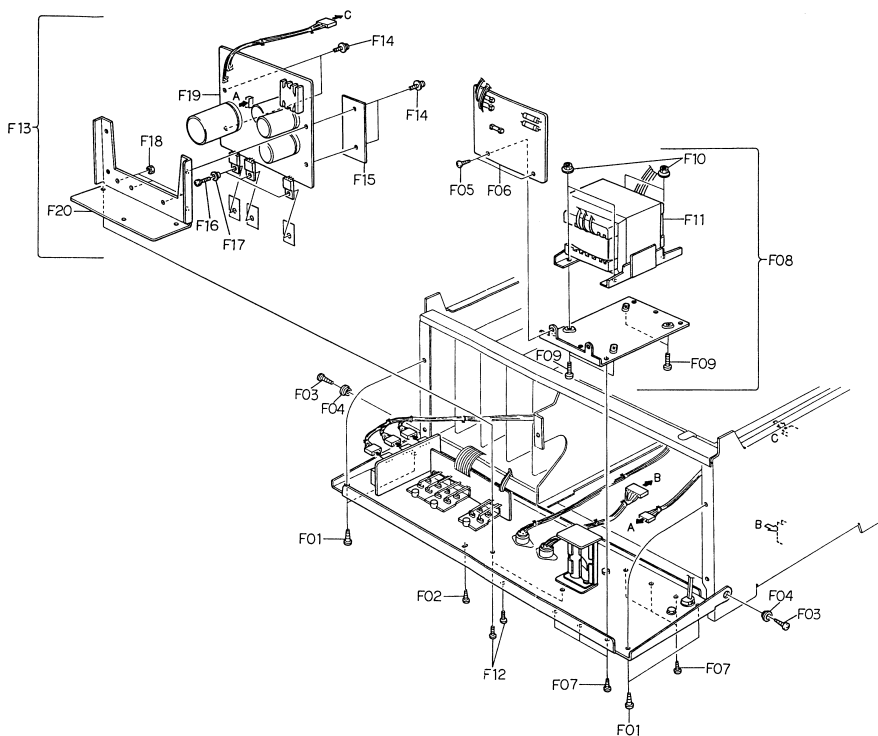

Fig. 2.4

2.11. Rear Panel Ass'y

Refer to Fig. 2.4.

- (1) Refer to Fig. 2.1. Remove Cabinet Ass'y referring to item 2.1.
- (2) Remove F01, F02, F03 and F04, then disassemble Rear Panel Ass'y (including 6 connectors and wires connected by wrapping).

2.12. Fuse P.C.B. Ass'y and Power Transformer

Refer to Fig. 2.4.

- (1) Remove Rear Panel Ass'y referring to item 2.11.
- (2) Remove F05, then disassemble F06 (Fuse P.C.B. Ass'y).
- (3) Remove F07, then disassemble F08 (Power Transformer Ass'y).
- (4) Remove F09 and F10, then disassemble F11 (Power Transformer).

2.13. Power Supply P.C.B. Ass'y

Refer to Fig. 2.4.

- (1) Remove Rear Panel Ass'y referring to item 2.11.
- (2) Remove F12, then disassemble F13 (Power Supply Ass'y including two connectors and wires connected by soldering on F19 Power Supply P.C.B. Ass'y).
- (3) Remove F14, then disassemble F15 (Insulator).
- (4) Remove F16, F17 and F18, then disassemble F19 (Power Supply P.C.B. Ass'y) and F20 (Heat Sink).

2.14. FL Indicator Ass'y, Volume Holder & Front Escutcheon B Ass'y, Display House Ass'y, Front Escutcheon A Ass'y, Headphone Jack Holder Ass'y and Front Panel Sub Ass'y

Refer to Fig. 2.5.

- (1) Refer to Fig. 2.2. Remove Front Panel Ass'y referring to item 2.3.
- (2) Remove F01, then disassemble F02 (FL Indicator Ass'y).
- (3) Remove F03 (Slide Volume Knob), F04, F05 and F06, then disassemble F07 (Volume Holder & Front Escutcheon B Ass'y).
- (4) Remove F08, then disassemble F09 (MIC Amp. & Volume P.C.B. Ass'y).
- (5) Remove F10, then disassemble F11 (Function P.C.B. Ass'y) and F12 (Front Escutcheon B Ass'y).
- (6) Remove F13, then disassemble F14 (Display House Ass'y).
- (7) Remove F15, then disassemble F16 (Display P.C.B. Ass'y) and F17 (Display House).
- (8) Remove F18, F19, F20 and F21, then disassemble F22 (Front Escutcheon A Ass'y).
- (9) Remove F23, then disassemble F24 (Mechanism Control Switch P.C.B. Ass'y).
- (10) Remove F25, then disassemble F26 (RAMM Control Switch P.C.B. Ass'y) and F27 (Front Escutcheon Sub A Ass'y).

2.15. FL Indicator P.C.B. Ass'y

Refer to Fig. 2.6.

- (1) Refer to Fig. 2.5. Remove FL Indicator Ass'y referring to item 2.14.
- (2) Remove F01, then disassemble F02 (FL Indicator

Case Cover).

- (3) Remove F03 (FL Indicator Holder L) and F04 (FL Indicator R), then disconnect 3 connectors. Disassemble F05 (FL Indicator P.C.B. A Ass'y) and F06 (FL Indicator P.C.B. B Ass'y).

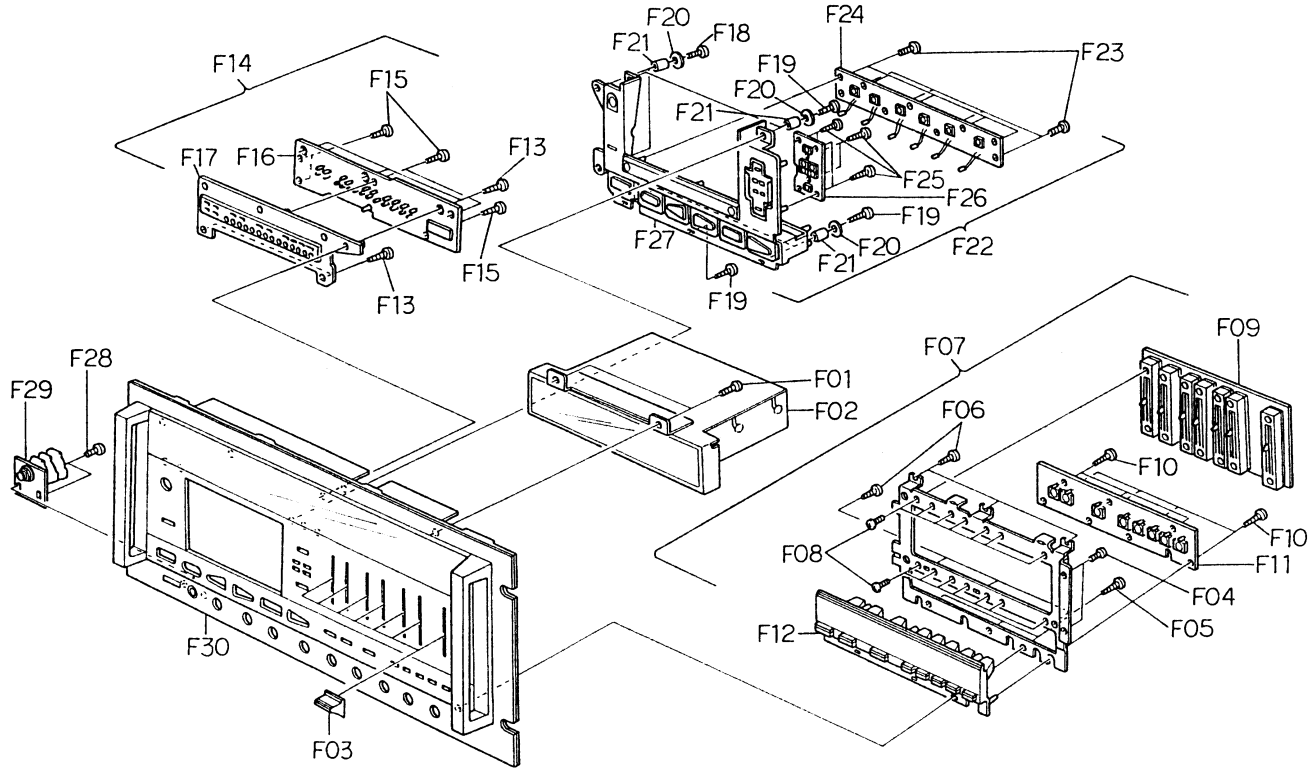

Fig. 2.5

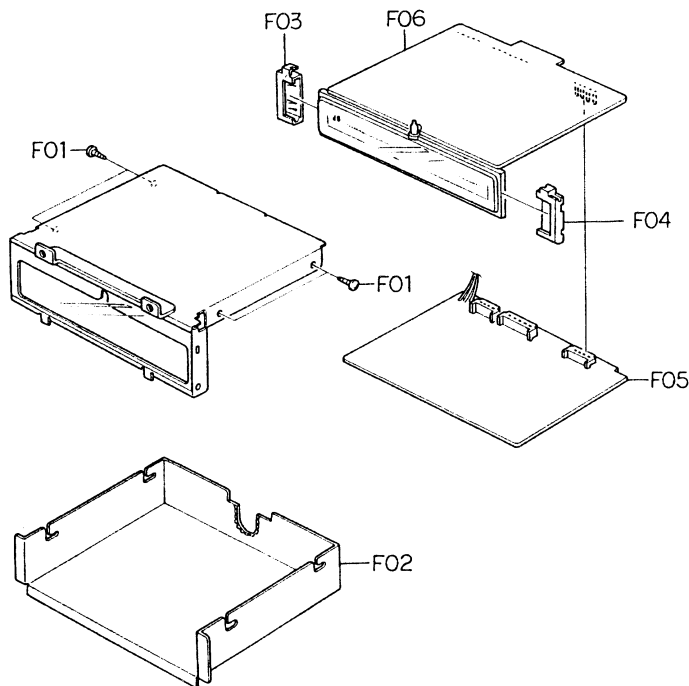

Fig. 2.6

2.16. Cassette Case Ass'y and Cover Plate Ass'y

Refer to Fig. 2.7.

- (1) Refer to Fig. 2.2. Remove Mechanism Ass'y referring to item 2.4.
- (2) Press the Eject Button to open the Cassette Case Ass'y.
- (3) Remove F01 and F02, then disassemble F03 (Cassette Case Holder L Ass'y) by releasing the Self-interlocking Pin of the Damper Lock Arm and F04 (Cassette Case Ass'y).
- (4) Remove F05, then disassemble F06 (Cover Plate Ass'y).

2.17. Capstan Motor Ass'y and Flywheel Ass'y

Refer to Fig. 2.8.

- (1) Refer to Fig. 2.2. Remove Mechanism Ass'y referring to item 2.4.
- (2) Remove F01 and F02, then disassemble F03 (Flywheel Holder Ass'y) and F08 (Capstan Belt).
- (3) Remove F04, then disassemble F05 (Capstan Motor Ass'y).
- (4) Remove F06, then disassemble F07 (Speed Cal.P.C.B. Ass'y).
- (5) Remove F09 (Supply Flywheel Ass'y), then disassemble F10 (Take-up Flywheel Ass'y).
- (6) After removing both Flywheel Assemblies, disassemble F11 (Thrust Washer 3 mm), F12 (Thrust Washer 2.6 mm), F13 (Flange Thrust Cap) and F14 (Thrust Spring).

2.18. Sub Mechanism Chassis Ass'y

Refer to Fig. 2.9.

- (1) Remove Flywheel Holder Ass'y referring to item 2.17.
- (2) Remove F01 and F02, then disassemble F03 (Sub Mechanism Chassis Ass'y).

2.19. Control Motor Ass'y and Reel Motor Ass'y

Refer to Fig. 2.9.

- (1) Remove Sub Mechanism Chassis Ass'y referring to item 2.18.
- (2) Remove F04, then disassemble F05 (Control Motor Ass'y).
- (3) Remove F06, then disassemble F07 (Reel Motor Ass'y).

2.20. Cam Control Volume

Refer to Fig. 2.9.

- (1) Remove Sub Mechanism Chassis Ass'y referring to item 2.18.
- (2) Remove F08, then disassemble F09 (Volume Coupler).
- (3) Remove F10, then disassemble F11 (Cam Control Volume).

2.21. Azimuth Motor Ass'y

Refer to Fig. 2.9.

- (1) Remove Sub Mechanism Chassis Ass'y referring to item 2.18.
- (2) Remove F12, then disassemble F13 (Azimuth Alignment Motor Ass'y).
- (3) Remove F14, then disassemble F15 (Azimuth Motor Ass'y) and F16 (Drive Pulley Ass'y).

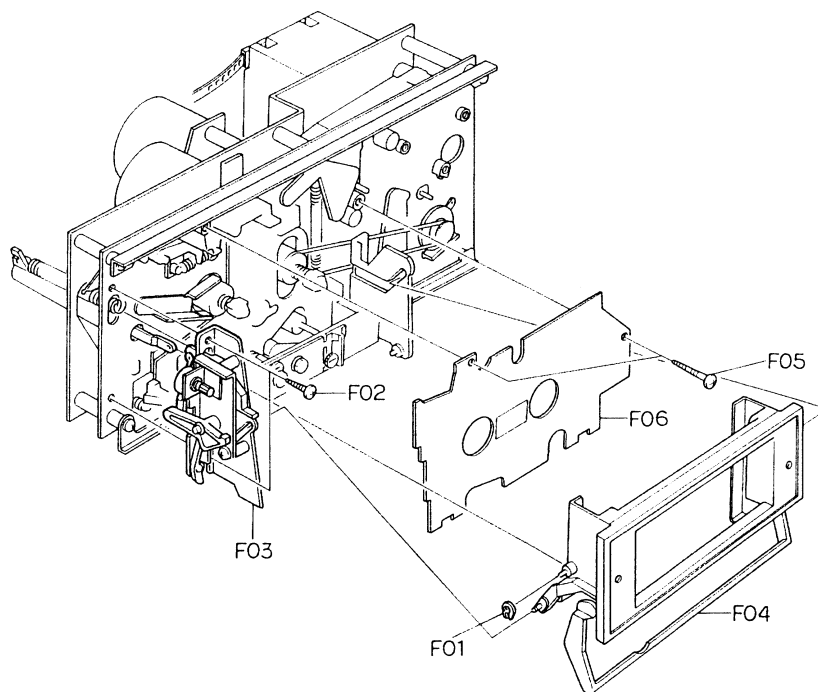

Fig. 2.7

2.22. Reel Hub Ass'y and Idler Ass'y

Refer to Fig. 2.9.

- (1) Remove Sub Mechanism Chassis Ass'y referring to item 2.18.
- (2) Remove F17 (Reel Hub Head), then disassemble F18 (Reel Hub B Ass'y), F19 (Reel Hub Take-up Ass'y), F20 (Reel Hub Supply Ass'y), F21 (Back Tension Ass'y) and F22 (Back Tension Spring).
- (3) Remove F23, then disassemble F24 (Idler Ass'y).

2.23. Cam Drive Gear and Control Cam

Refer to Fig. 2.9.

- (1) Remove Sub Mechanism Chassis Ass'y referring to item 2.18.

- (2) Remove F25, then disassemble F26 (Cam Drive Gear).
- (3) Remove F27, then disassemble F28 (Counter-Load Arm Ass'y).
- (4) Remove F29, then disassemble F30 (Control Cam).

2.24. Counter Pulse Generator P.C.B. Ass'y

Refer to Fig. 2.9.

- (1) Remove Sub Mechanism Chassis Ass'y referring to item 2.18.
- (2) Remove F31, then disassemble F32 (Counter Pulse Generator P.C.B. Ass'y).

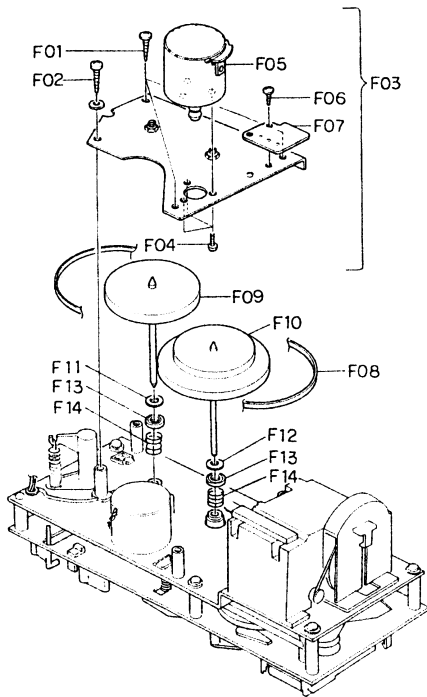

Fig. 2.8

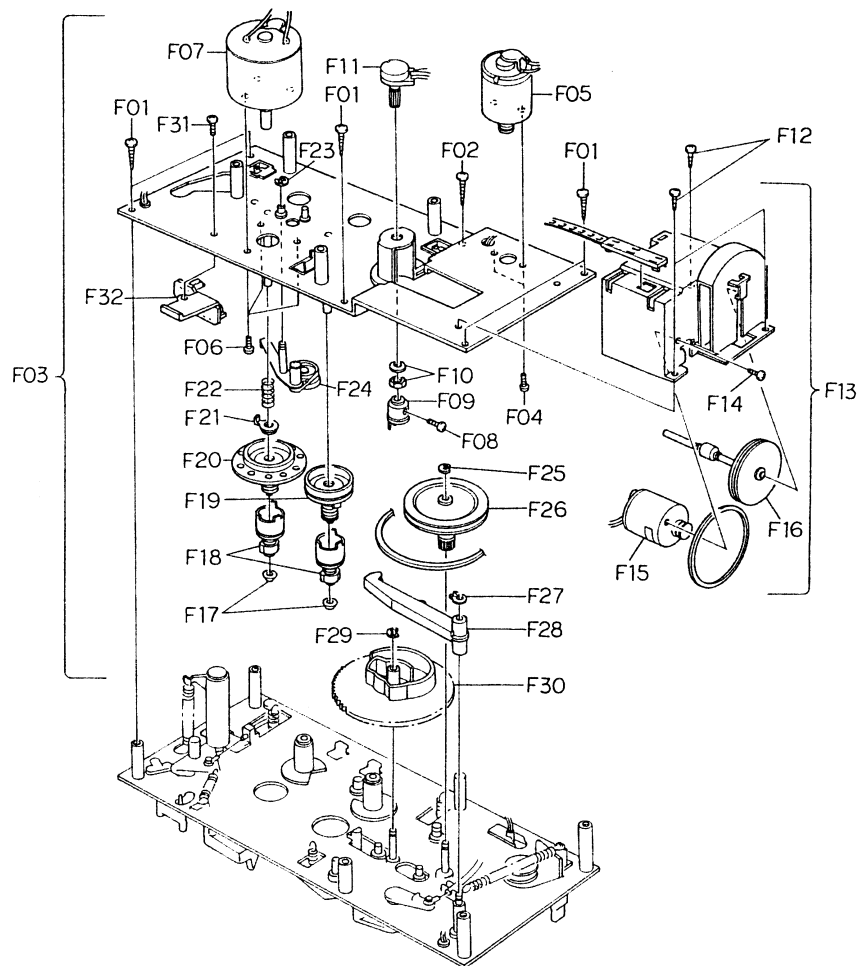

Fig. 2.9

2.25. Head Mount Base Ass'y

Refer to Fig. 2.10.

- (1) Refer to Fig. 2.7. Remove Cassette Case Ass'y referring to item 2.16.
- (2) Remove F01, then disassemble F02 (Head Mount Base Ass'y).

2.26. Pressure Roller Ass'y and Erase Head

Refer to Fig. 2.10.

- (1) Remove Head Mount Base Ass'y referring to item 2.24.
- (2) Remove F03, then disassemble F04 (Supply Pressure Roller Ass'y).
- (3) Remove F05, then disassemble F06 (Erase Head).
- (4) Remove F07, then disassemble F08 (Take-up Pressure Roller Ass'y).

2.27. Playback Head Ass'y and Record Head Ass'y

Refer to Fig. 2.10.

- (1) Remove Head Mount Base Ass'y referring to item 2.24.
- (2) Turn F09 by 90° by pushing it, then disassemble F10 (Playback Head Ass'y).
- (3) Turn F11 by 90° by pushing it, then disassemble F12 (Record Head Ass'y) and F13 (RH Azimuth Alignment Plate).

2.28. Battery

Refer to Fig. 2.11.

- (1) Turn fully counterclockwise the screw which is mounted on the Rear Panel Ass'y, then pull out Battery Case Ass'y.
- (2) Pull up the Ribbon in Battery Case. Then take out Batteries from Battery Case.

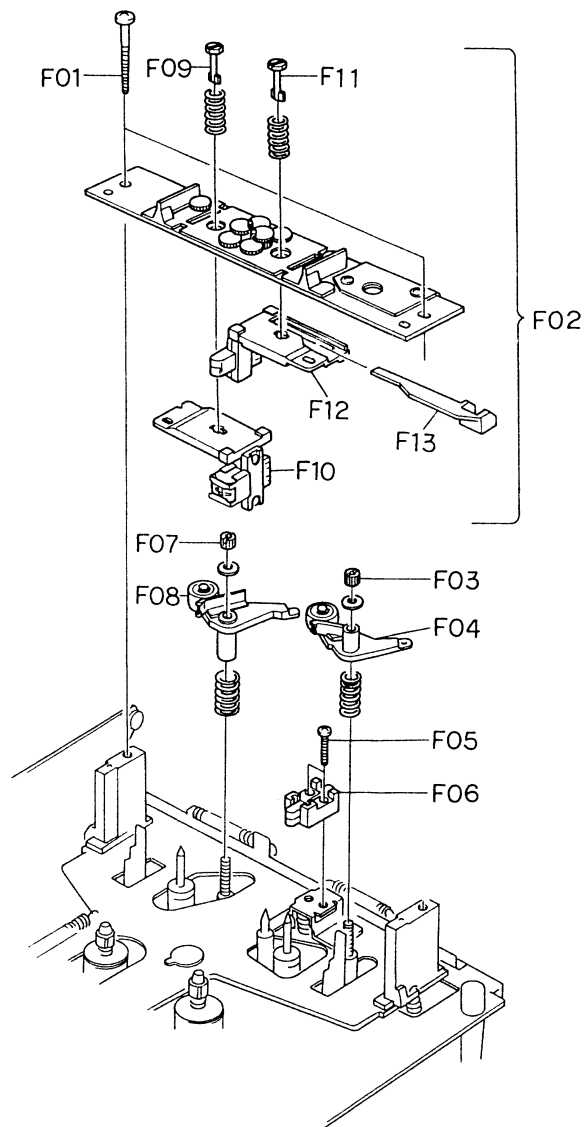

Fig. 2.10

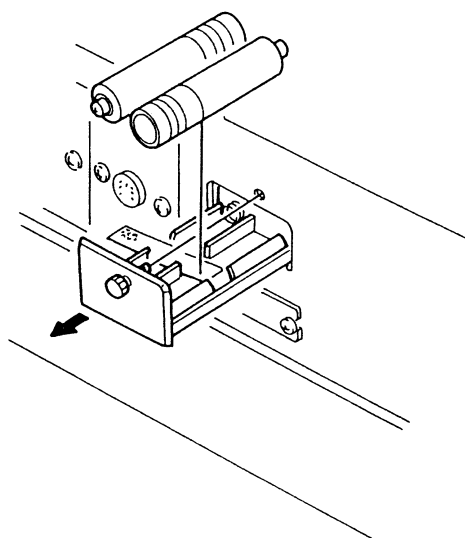

Fig. 2.11

3. MEASUREMENT AND MAINTENANCE INSTRUMENTS

3.1. Measurement Instruments

- (1) Audio Generator (20 Hz – 200 kHz)
- (2) AC Millivolt Meter (with dB measures)
- (3) Oscilloscope (DC – 5 MHz)
- (4) Distortion Meter
- (5) Speed & Wow/Flutter Meter
- (6) Frequency Counter (DC –10 MHz)
- (7) Ohm Meter
- (8) DC Volt Meter
- (9) AC Volt Meter
- (10) Torque Gauge (DA09013A)
- (11) 15 kHz Azimuth Tape (DA09004A)
- (12) 3 kHz Speed & Wow/Flutter Tape (DA09006A)
- (13) 1 kHz Track Alignment Tape (DA09007A)
- (14) 400 Hz Level Tape (DA09005A)
- (15) 20 kHz PB Frequency Response Tape (DA09001A)
- (16) 15 kHz PB Frequency Response Tape (DA09002A)
- (17) 10 kHz PB Frequency Response Tape (DA09003A)
- (18) Reference EXII Tape (DA09021A)
- (19) Reference SX Tape (DA09025A)
- (20) Reference ZX Tape (DA09037A)
- (21) Tilt Check Gauge M-9039 (DA09039A)
- (22) EH Tilt Check Gauge M-9040 (DA09040A)
- (23) EH Stroke Check Gauge M-9051 (DA09051A)
- (24) Stroke Check Gauge M-9047 (DA09047B)
- (25) Record Head Mounting Gauge M-9048 (DA09048A)
- (26) Back Tension Gauge (DA09055A)
- (27) Tension Arm Adjustment Cassette (DA09056A)
- (28) 5 Hz RAMM Speed Check Tape (DA09061A)
- (29) Test Unit M-9057 (DA09057A)
- (30) Extension Card M-9058 (DA09058A)
- (31) Audio Analyzer T-100
(including Distortion, Wow/Flutter, Speed, Oscillator and dB meter)

Note: (10) – (31) are the products of Nakamichi Corporation.

3.2. Maintenance Instruments (1) Test Unit

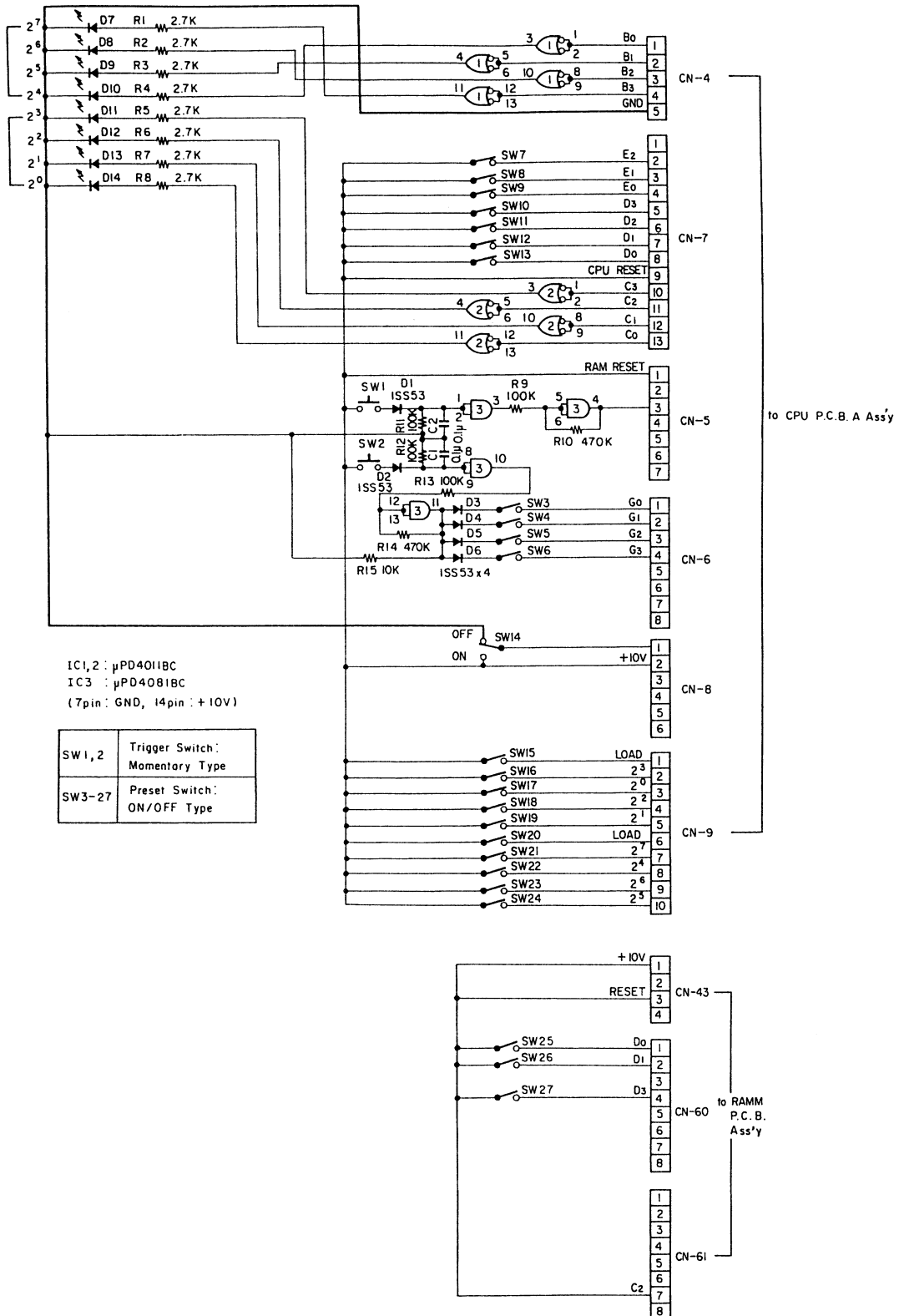

Fig. 3

4. MECHANICAL ADJUSTMENT

4.1. Mechanism Control Cam Adjustment

Before adjustment, disassemble the Front Panel Ass’y, then remove the Cover Plate Ass’y referring to items 2.3 and 2.16.

(1) Offset Adjustment of Control Motor Driver

- (a) Refer to Figs. 4.1 and 4.2.
Adjust VR505 and VR506 on the Logic P.C.B. Ass’y to locate approximately at the middle of the variable range. Then press the Power switch.
VR506 (for Cam position stop)
VR505 (for Cam position play)
- (b) Press the Stop button to set the N-1000ZXL in Stop mode.
Adjust VR506 (for stop) so that the “S” mark on the Cam corresponds to the pointer on the mechanism chassis.
- (c) Press the Play button to set the N-1000ZXL in Playback mode.
(Cam will rotate, and the position marked with “PY” comes to the pointer.) Adjust VR505 (for play) so that the “PY” mark on the Cam corresponds to the pointer.
- (d) Repeat above (b) and (c) 2 – 3 times so that the “S” and “PY” marks on the Cam correspond to the pointer accurately in Stop and Playback modes respectively.
(This adjustment is required because the position adjusted by one volume will be slightly changed when the other volume is adjusted.)

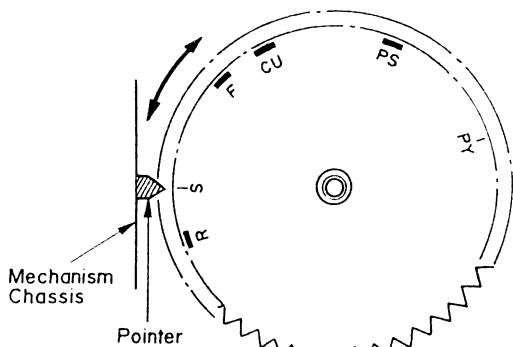

Fig. 4.1

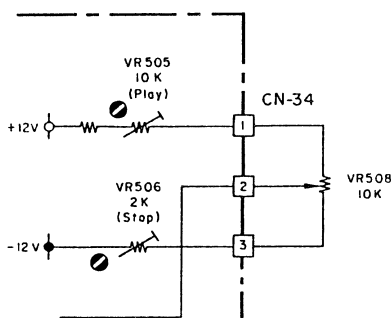

Fig. 4.2

- (e) Set the N-1000ZXL in F.F., Pause, or Cue mode by pressing each button (press F.F. and Pause buttons to set the N-1000ZXL in Cue mode) and check to insure that the pointer is in a range of “F”, “PS”, or “CU” mark respectively.
- (f) If out of the range, precise adjustment for each position according to “(2) Offset Fine Adjustment of Control Motor Driver” will be required.

(2) Offset Fine Adjustment of Control Motor Driver

Adjust only if a satisfactory result is not obtained in “(1) Offset Adjustment of Control Motor Driver”. This adjustment is made by changing the value of the fixed resistors on the Logic P.C.B. Ass’y.
Note: The value of voltage is typical value.

(a) Observation Point of Reference Voltage

Observe the each voltage at the sliding contact of the Cam Control Volume VR508 (10 kΩ) in Stop, Fast (F.F. or Rewind), Pause and Playback modes.

(b) Reference Voltage

Reference voltage at the sliding contact of VR508 (Cam Control Volume) in each mode is as follows:

Mode	Reference Voltage (Typical Value)
Stop	-0.4 V
Fast (F.F./Rew.)	-2.1 V
Pause	-6.2 V
Play	-8.8 V

} 1.7 V ±0.25 V
} 2.6 V ±0.4 V

(c) Resistors for Adjustment

Mode	Ref. No.	Typical Value
Stop	R518	316 kΩ (F)
Fast (F.F./Rew.)	R519	33 kΩ
Pause	R522	51.1 kΩ (F)
Play	R520	71.5 kΩ (F)

(d) Adjustment Procedures

- 1) Press the Stop button to set the N-1000ZXL in Stop mode.
Adjust the value of R518 to obtain -0.4 V (±0.6 V) at the sliding contact of VR508.
Note: When R518 is adjusted, the reference voltage in Fast (F.F. or Rewind) mode is changed. Therefore, re-check of the reference voltage in Fast mode is required. If the reference voltage is out of the range, re-adjustment of R519 according to next step 2) is necessary.
- 2) Set the N-1000ZXL in F.F. mode, then adjust the value of R519 so that the voltage of VR508 will become lower by 1.7 V (±0.25 V) than in Stop mode.
- 3) Press the Pause button to set the N-1000ZXL in Pause mode.
Adjust the value of R522 to obtain -6.2 V (+0.4, -0.15 V) at the sliding contact of VR508.

- 4) Set the N-1000ZXL in Playback mode, then adjust the value of R520 so that the voltage of VR508 will become lower by 2.6 V (± 0.4 V) than in Pause mode.

(3) Cam Timing Adjustment

- (a) Remove the wires from the Control Motor terminals to set the motor open.
- (b) Without loading a cassette tape and with pressing the record protecting switch with your finger tip, press the Record and Play buttons to set the N-1000ZXL in Record mode.
- (c) Turn the Cam and bring the "PY" mark toward the pointer by hand. Reel Motor will rotate before the "PY" mark reaches the pointer. Adjust the value of R560 and R561 so that the voltage at the sliding contact of VR508 becomes -7 V (± 0.3 V) when Reel Motor starts rotation.
- (d) Observe the mute signal at the Q523 collector. Turn the Cam referring to above step (c) and check to insure that the voltage at the sliding contact of VR508 is -7.2 V (± 0.3 V) when mute is released (mute signal changes from H to L). (This voltage is determined by the adjustment of R560 and R561 in above step (c).)
- (e) Upon completion of the above adjustment, re-connect wires to the motor terminals.

4.2. Reel Motor Speed Adjustment in Play Mode

Refer to Fig. 4.3.

- (1) Connect a DC voltmeter across the Reel Motor terminals.
- (2) Without loading a cassette tape, set the N-1000ZXL in Play mode.
- (3) Adjust VR501 on the Logic P.C.B. Ass'y to obtain 4 V on the DC voltmeter.

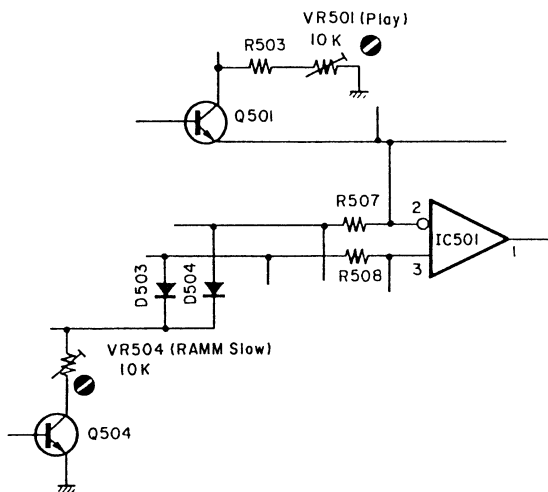

Fig. 4.3

4.3. RAMM Mode Adjustment

Before adjustment, disassemble the CPU P.C.B. Shield Plate, then remove 3 screws which are mounted on the CPU P.C.B. Ass'y.

Then lift the CPU P.C.B. Ass'y and insert connectors CN-43, 60 and 61 of the Test Unit into the connectors CN-43, 60 and 61 of the RAMM P.C.B. Ass'y. After the adjustment is completed, remove the Test Unit and assemble the CPU P.C.B. Shield Plate.

(1) Head Base Stroke Adjustment in RAMM Cue Mode

Refer to Figs. 4.4 and 4.5

- (a) Load a Stroke Check Gauge M-9047 (DA09047B) in the N-1000ZXL.
- (b) Move Record Head Indicator and Playback Head Indicator to the direction of arrow mark "A" with your finger tip and then set the N-1000ZXL in RAMM mode. Then slowly release the Indicators and insure whether each of the Indicators is in contact with record and playback heads.
- (c) Check to insure whether the "C" pointer on the Playback Head Indicator indicates the left side line on the Indicator Plate.
- (d) If the playback head stroke is noted to be misaligned, adjust VR502 on the Logic P.C.B. Ass'y till satisfactory results are obtained.
- (e) After completion of the above adjustment, set the N-1000ZXL in Stop mode, then set in RAMM mode again to see whether the adjustment is appropriately made. If not, (b) through (e) will have to be repeated till satisfactory result is obtained.

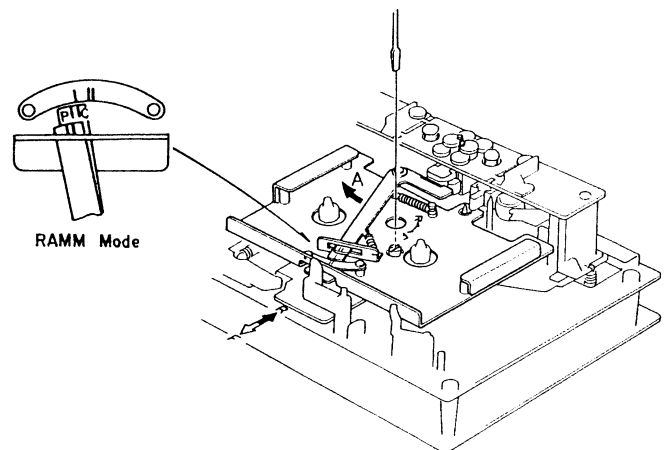

Fig. 4.4

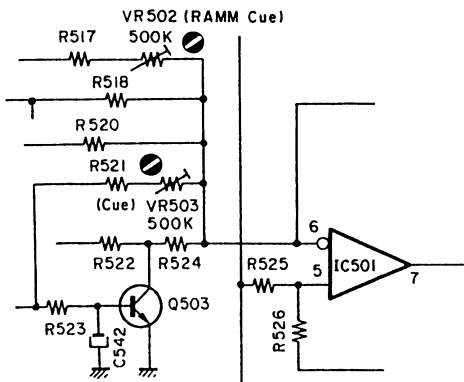

Fig. 4.5

- (e) By setting SW27 of the Test Unit to OFF (SW25 and SW26 are ON), set the N-1000ZXL in RAMM Fast mode, then check to insure that the lowest plus peak value of waveforms is higher than 0.5 V DC. If not repeat (c) – (e) till satisfactory result is obtained.
- (f) Set SW25, SW26 and SW27 to OFF, then set the N-1000ZXL in Stop mode.

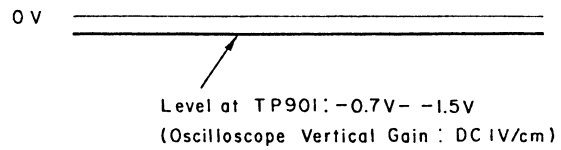

Fig. 4.6

(2) Reel Motor Speed Adjustment in RAMM Slow Mode
Refer to Fig. 4.3.

- (a) Load a 5 Hz RAMM Speed Check Tape (DA09061A) in the N-1000ZXL.
- (b) Connect a Frequency Counter to TP901 on the Detector P.C.B. Ass'y.
- (c) Set SW25, SW26 and SW27 of the Test Unit to ON.
- (d) Set the N-1000ZXL in Fast (F.F. or Rewind) mode, then adjust VR504 on the Logic P.C.B. Ass'y so that the reading of the Frequency Counter becomes in a range of 25 – 50 Hz (typically 37.5 Hz).

After the adjustment, check to insure that the reading is in a range of 25 – 50 Hz at 3 different portions (beginning, middle and end) of the tape.

- (e) In Fast mode, by setting SW27 of the Test Unit to OFF, set the N-1000ZXL in RAMM Fast mode. In this RAMM Fast mode, check to insure that the reading of the Frequency Counter is in a range of 80 – 240 Hz. If not, repeat (b) – (e) till satisfactory result is obtained.
- (f) Set SW25, SW26 and SW27 of the Test Unit to OFF, then set the N-1000ZXL in Stop mode.

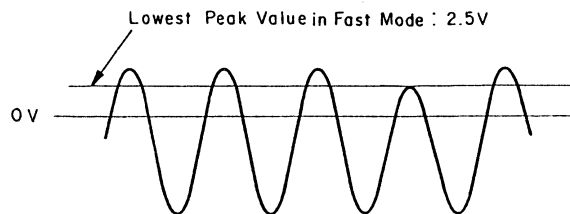

Fig. 4.7

(3) RAMM Detector Amp. Gain Adjustment

Refer to Figs. 4.6 – 4.8.

- (a) Load a 5 Hz RAMM Speed Check Tape (DA09061A) in the N-1000ZXL.
- (b) Connect a Synchroscope to TP901 on the Detector P.C.B. Ass'y. Set Synchroscope to DC mode and 1 V/cm vertical gain. Check to insure that the minus level (-0.7 to -1.5 V) is observed on the Synchroscope as shown in Fig. 4.6.
- (c) Set SW25, SW26 and SW27 of the Test Unit to ON.
- (d) Set the N-1000ZXL in Fast (F.F. or Rewind) mode, then adjust VR901 on the Detector P.C.B. Ass'y so that the lowest plus peak value of waveforms does not lower than 2.5 V DC as shown in Fig. 4.7.

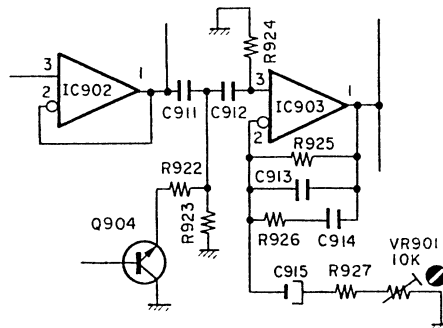

Fig. 4.8

4.4. Record Head and Playback Head Tilt Adjustment

Note: On items 4.4 – 4.10, refer to Fig. 4.9 flow chart.
Refer to Figs. 4.10 and 4.11.

- (1) Load a Tilt Check Gauge M-9039 (DA09039A) in the N-1000ZXL.
- (2) Clip the grounding terminal of the Tilt Check Gauge with one end of the cord with clip, and the other end to the chassis of the N-1000ZXL.
- (3) Remove both of the Height Gears.
- (4) Set the N-1000ZXL in Play mode. Check to insure whether the Beacons Playback Head "Upper" or "Lower" and Record Head "Upper" or "Lower" are illuminating. In order not to give damages onto the head surfaces, push both of slide knobs of the Gauge to the direction of arrow marks, then return them to the original place to be in contact with record head and playback head surfaces after Play mode is securely locked.
- (5) Check to insure freedom from contact between the Gauge and pad lifter.
- (6) Beacon Playback Head "Lower" will light on when height adjustment screw (P) turned clockwise but Playback Head "Upper" when counterclockwise. Adjust so that both "Upper" and "Lower" will light on even when you move the slide knob to the direction of an arrow mark and then return them to the original place.
- (7) Same procedures will apply to the Beacons Record Head "Upper" and "Lower", except for the height adjustment screw (R).
- (8) Set the N-1000ZXL in Stop mode and fit both of the serrated height gears. Then set the N-1000ZXL again in Play mode and insure all of the 4 Beacons are illuminating. If not, (3) through (7) will have to be repeated till satisfactory results are obtained.

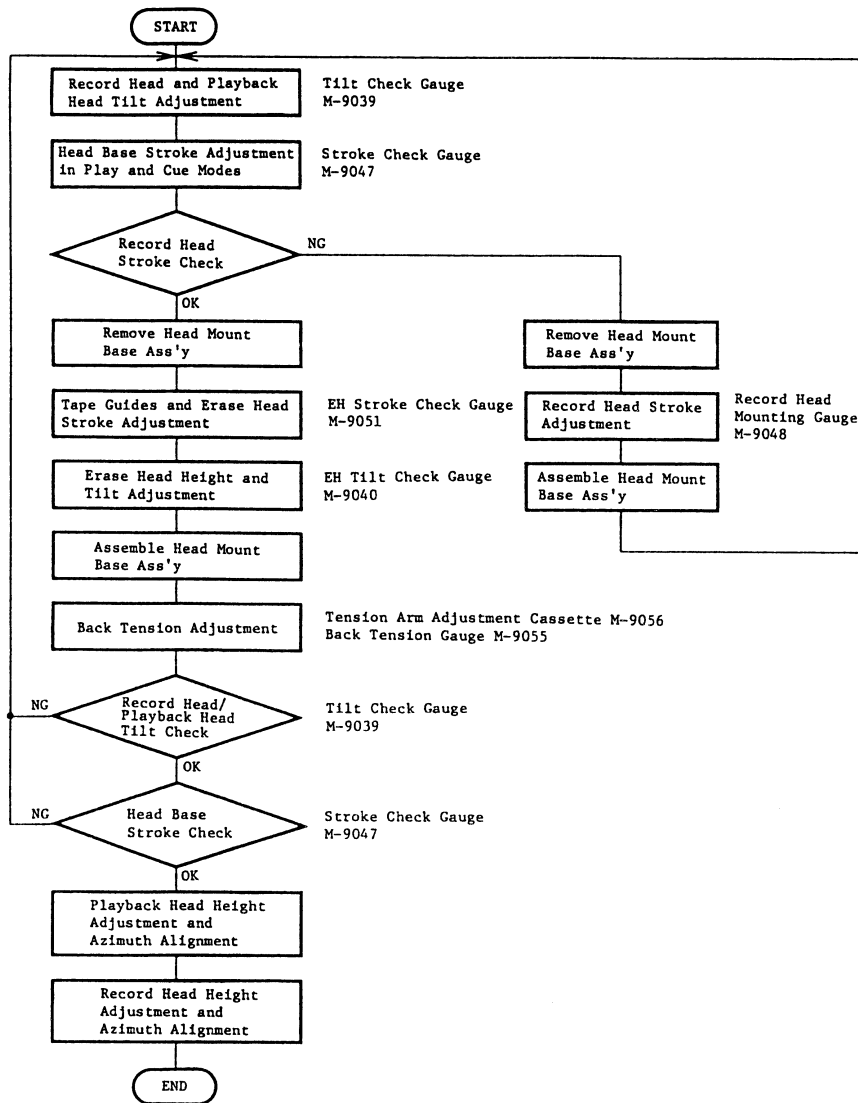

Fig. 4.9

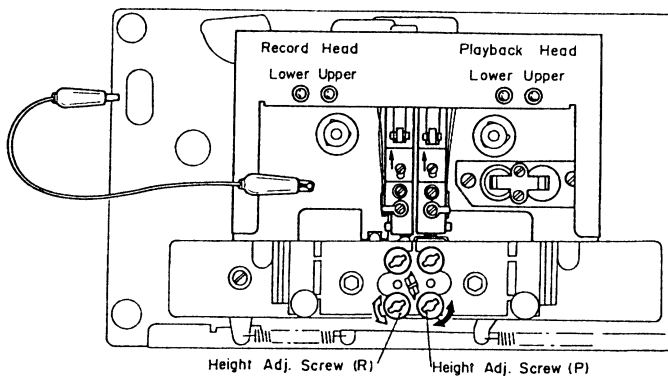

Fig. 4.10

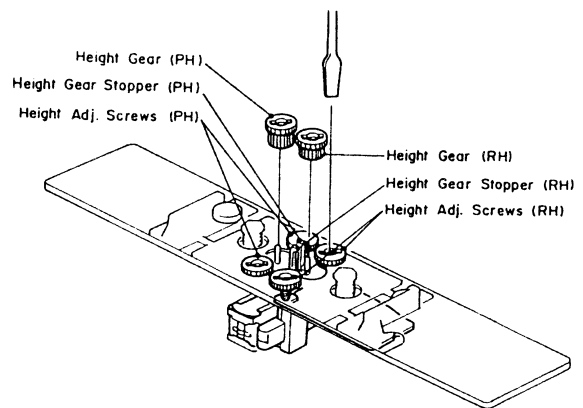

Fig. 4.11

4.5. Head Base Stroke Adjustment

Note: Before you conduct this adjustment, adjust with a "Tilt Check Gauge" to insure freedom from tilt on the playback head and record head.

(1) Head Base Stroke Adjustment in Play Mode

Refer to Fig. 4.12.

- (a) Load a Stroke Check Gauge M-9047 (DA09047B) in the N-1000ZXL.
- (b) Move Record Head Indicator and Playback Head Indicator to the direction of arrow mark "A" with your finger tip and then set the N-1000ZXL in Play mode. Then slowly release the Indicators and insure whether each of the Indicators is in contact with record and playback heads.
- (c) Check to insure whether the "P" pointer on the Playback Head Indicator locates between the 2 lines on the Indicator Plate.
- (d) If the playback head stroke is noted to be misaligned, adjustment can be made by moving the stroke adjuster assembled in the head base assembly (either forwardly or backwardly).
- (e) Check to insure whether the "P" pointer on the Playback Head Indicator locates between the 2 lines on the Record Head Indicator, thus check can be made on record head stroke.
- (f) If the record head stroke is noted to be misaligned, adjustment can be made with a Record Head Mounting Gauge M-9048 (DA09048A).

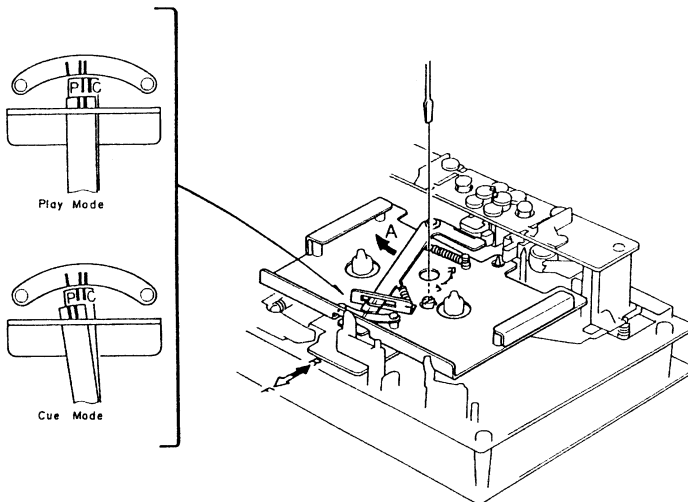

Fig. 4.12

(2) Head Base Stroke Adjustment in Cue Mode

Refer to Figs. 4.12 and 4.13.

- (a) Load a Stroke Check Gauge M-9047 (DA09047B) in the N-1000ZXL.
- (b) Move Record Head Indicator and Playback Head Indicator to the direction of arrow mark "A" with your finger tip and then set the N-1000ZXL in Cue (F.F. and Pause) mode. Then slowly release the Indicators and insure whether each of the Indicators is in contact with record and playback heads.
- (c) Check to insure whether the "C" pointer on the Playback Head Indicator locates between the 2 lines on the Indicator Plate.
- (d) If the playback head stroke is noted to be misaligned, adjust VR503 on the Logic P.C.B. Ass'y till satisfactory results are obtained.
- (e) After completion of the Head Base Stroke Adjustment, check to insure accuracy of the Head Base Stroke Adjustment in Play mode. If the above are inaccurate, items (1) and (2) will have to be repeated till satisfactory results are obtained.

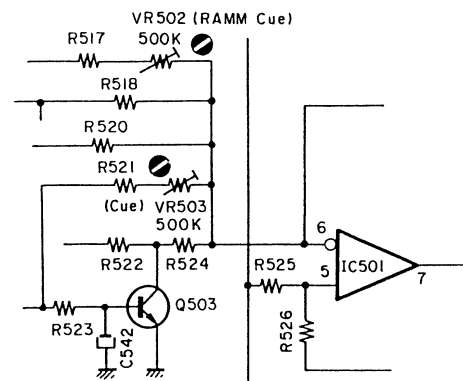

Fig. 4.13

4.6. Tape Guides Adjustment and Erase Head Stroke Adjustment

Remove Head Mount Base Ass'y referring to item 2.25. Refer to Figs. 4.14 and 4.15.

(1) Supply Tape Guide Height Adjustment

- (a) Load an EH Stroke Check Gauge M-9051 (DA-09051A) in the N-1000ZXL.
- (b) Set the N-1000ZXL in Play mode.
- (c) Slide the Supply Tape Guide Check Bar down against the supply tape guide, thus check can be made on supply tape guide height.
- (d) If the supply tape guide is misaligned, the Supply Tape Guide Check Bar will not come into the supply tape guide. If such is noted, turn to adjust the height adjustment nut A till the Supply Tape Guide Check Bar is accepted by the supply tape guide.
- (e) If the above are insured, set the N-1000ZXL in Pause mode, then in Play mode to see whether adjustments are appropriately made. If not, (b) through (e) will have to be repeated till satisfactory results are obtained.

(2) Take-up Tape Guide Height Adjustment

- (a) Load an EH Stroke Check Gauge M-9051 (DA-09051A) in the N-1000ZXL.

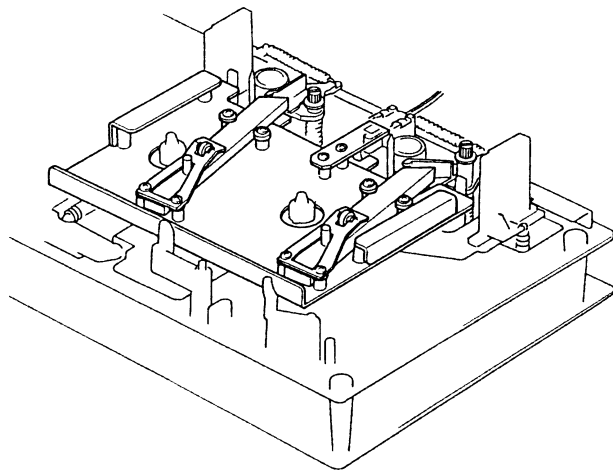

Fig. 4.14

- (b) Set the N-1000ZXL in Play mode.
- (c) Slide the Take-up Tape Guide Check Bar down against the take-up tape guide, thus check can be made on take-up tape guide height.
- (d) If the take-up tape guide is misaligned, the Take-up Tape Guide Check Bar will not come into the take-up tape guide. If such is noted, turn to adjust the height adjustment nut C till the Take-up Tape Guide Check Bar is accepted by the take-up tape guide.
- (e) If the above are insured, set the N-1000ZXL in Pause mode, then in Play mode to see whether adjustments are appropriately made. If not, (b) through (e) will have to be repeated till satisfactory results are obtained.

(3) Erase Head Stroke Adjustment

- (a) Load an EH Stroke Check Gauge M-9051 (DA-09051A) in the N-1000ZXL.
- (b) Set the N-1000ZXL in Play mode, thus check can be made on erase head stroke through the EH Stroke Indicator.
- (c) Check to insure whether the erase head surface is aligned with red line on the EH Stroke Indicator. If not, adjust the erase head stroke by loosening 2 screws B that assembled erase head and erase head plate.
- (d) After completion of adjustment, 2 pcs. of screws shall be locked with lock tight paint.

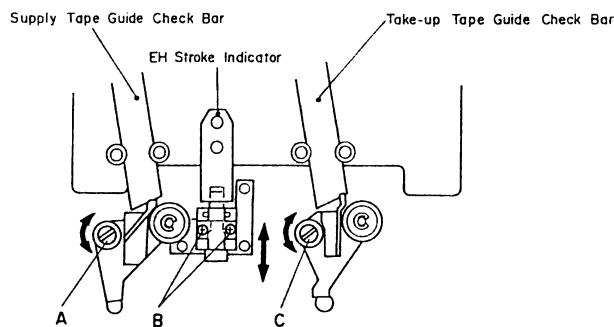

Fig. 4.15

4.7. Erase Head Height and Tilt Adjustment

Refer to Figs. 4.16 and 4.17.

- (1) Remove Head Mount Base Ass'y referring to item 2.25.
- (2) Load an EH Tilt Check Gauge M-9040 (DA09040A) in the N-1000ZXL.
- (3) Set the N-1000ZXL in Stop mode.
- (4) Check to insure whether one of the 3 Beacons is illuminating. Look down the mirror as shown by an arrow mark and slowly turn the Screw "Height" counterclockwise (or clockwise) so that the two horizontal lines on the mirror will become superposed on the line (in different color) of the erase head, and check to insure whether Beacon "1" is illuminating.
- (5) Turn Screw "Tilt" counterclockwise (or clockwise) to light on Beacon "2". Excessive turning will cause the Beacon "1" to light off. Adjustments of Screw "Tilt" will therefore be conducted till both of the Beacons "1" and "2" illuminate.
- (6) Turn Screw "Azimuth" counterclockwise or clockwise to light on Beacon "3". Excessive turning will cause either Beacon "1" or "2" to light off, and therefore adjust with Screw "Azimuth" until all of the 3 Beacons "1", "2" and "3" illuminate.
- (7) Check to insure whether the horizontal line on the mirror corresponds to that on the erase head. If not, (4) through (7) will have to be repeated till satisfactory results are obtained.
- (8) After completion of adjustment, 3 pcs. of screws shall be locked with lock tight paint.

Note: Before use of this gauge, check to insure freedom from dust or dirt, or overflow in the groove of the erase head surface.

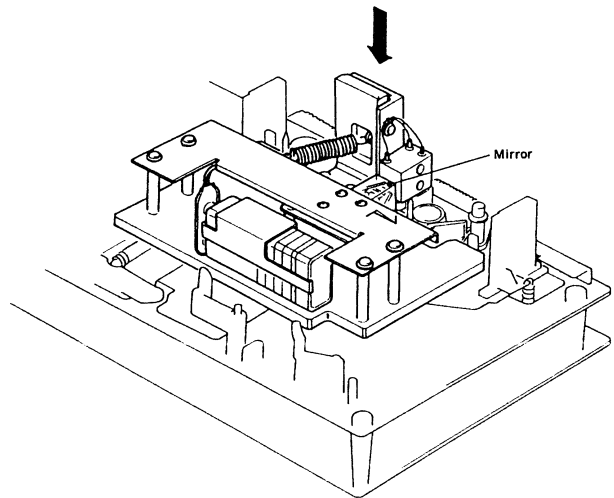

Fig. 4.16

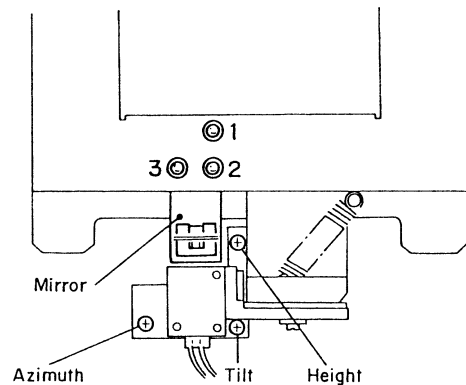

Fig. 4.17

4.8. Back Tension Adjustment

Refer to Figs. 4.18 – 4.21.

- (1) Load a Tension Arm Adjustment Cassette (DA 09056A) in the N-1000ZXL referring to Fig. 4.18.
- (2) Set the N-1000ZXL in Play mode.
- (3) Bend the Back Tension Arm with pliers so that the gap between the Cassette Holding Spring assembled with the Head Base Ass’y and the Back Tension Arm becomes 0.5 mm as shown in Fig. 4.19. Do not bend the pointed end of the Back Tension Arm.
- (4) Set the N-1000ZXL in Stop mode, and remove the Tension Arm Adjustment Cassette (DA09056A), then set the N-1000ZXL in Cue mode.

In Cue mode, check to insure that the gap is found between the Supply Reel Hub B Ass’y and the Felt of Back Tension Ass’y as shown in Fig. 4.20.

- (5) Load the Back Tension Gauge (DA09055A) in the N-1000ZXL.
- (6) Set the N-1000ZXL in Play mode and read the torque value of Back Tension Gauge.

If the value is in a range of 6 g-cm to 10 g-cm, adjustment is not necessary. If not, change the installation point of the Back Tension Spring as shown in Fig. 4.21, and obtain the torque of 7 g-cm to 9 g-cm range.

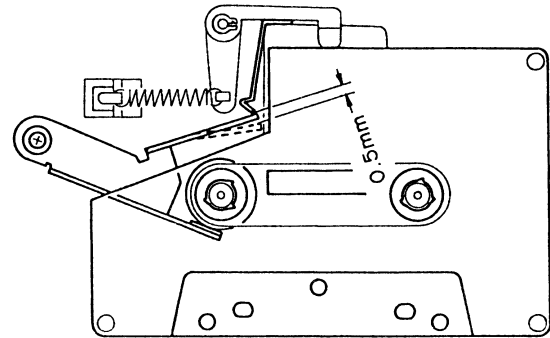

Fig. 4.19

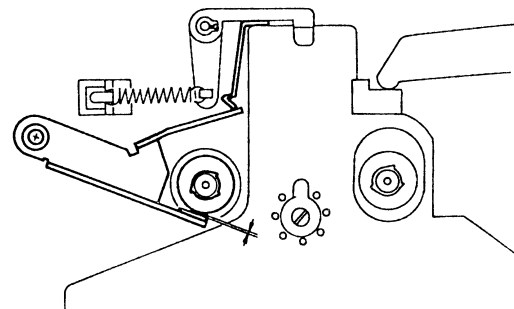

Fig. 4.20

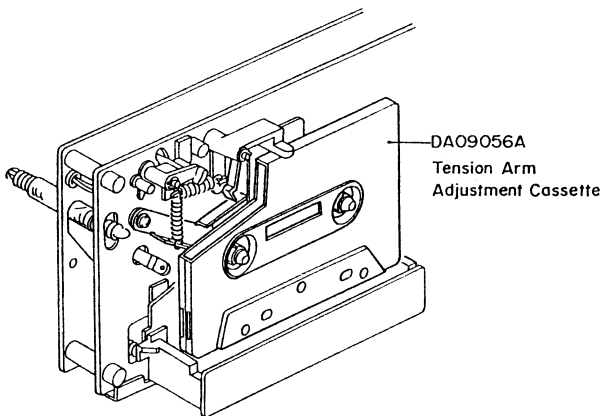

Fig. 4.18

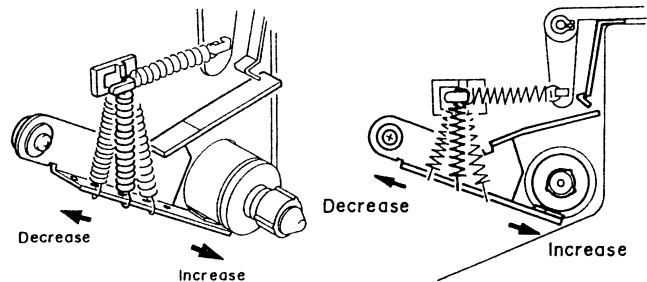

Fig. 4.21

4.9. Playback Head and Record Head Height Adjustment and Azimuth Alignment

(1) Playback Head Height Adjustment and Azimuth Alignment

Refer to Fig. 4.22.

- Set the Monitor switch to Tape, then connect a VTVM to the Line Output Jacks.
- Set the Manual Set button, then set the Eq. switch to 70 μ s and Noise Reduction switch to Out.
- Load a 1 kHz Track Alignment Tape (DA09007A), then set the N-1000ZXL in Play mode.
- Turn the PH Height Gear until the outputs of both channels become minimum.
- Load a 15 kHz Azimuth Tape (DA09004A), then set the N-1000ZXL in Play mode.
- Turn the PH Azimuth Alignment Screw until the outputs of both channels become maximum.
- Repeat above steps (c) through (f) one or two times to obtain optimum performance.

(2) Record Head Height Adjustment and Azimuth Alignment

Refer to Figs. 4.22 – 4.26.

- Set the N-1000ZXL in Stop mode.
Turn the Azimuth Motor in the Azimuth Alignment Motor Ass'y by hand so that the Alignment Indicator corresponds to the pointer of the Azimuth Alignment Motor Ass'y as shown in Fig. 4.23. Remove the Azimuth Alignment Wire by pulling out from the Azimuth Alignment Motor Ass'y. In this case, do not move the Slide Lever of the Azimuth Alignment Wire.
- Set the Monitor switch to Tape, then connect a VTVM to the Line Output Jacks.
- Set the Eq. switch to 70 μ s and Noise Reduction switch to Out.
- Load a Reference SX Tape (DA09025A). Then set the N-1000ZXL in Record and Pause mode.
- With pressing the Auto Calibration button "Run", press the Play button to set the N-1000ZXL in Auto Calibration mode.

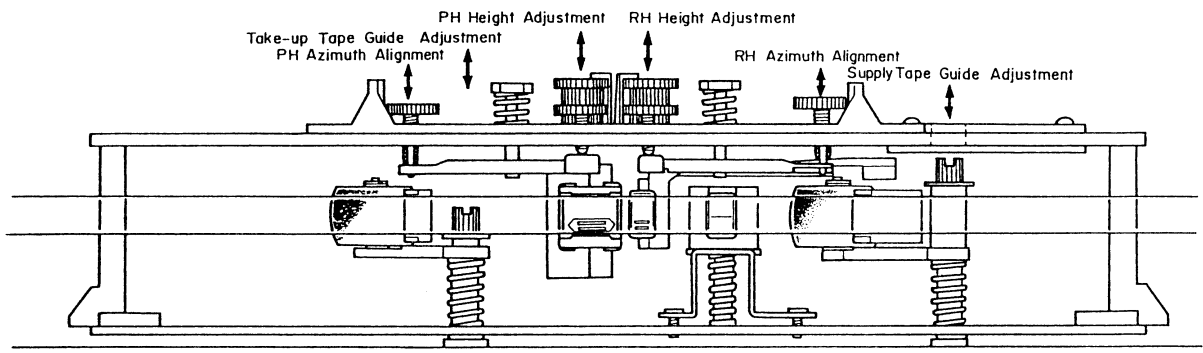

Fig. 4.22

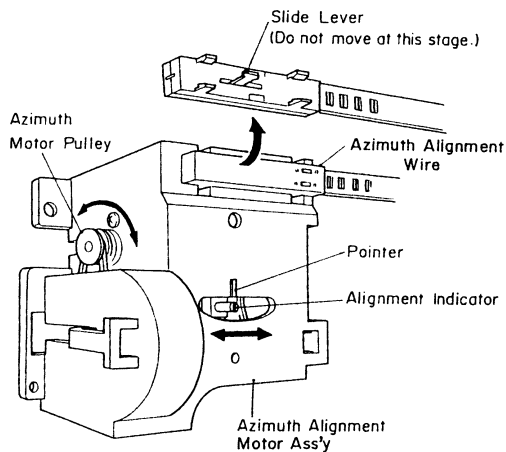

Fig. 4.23

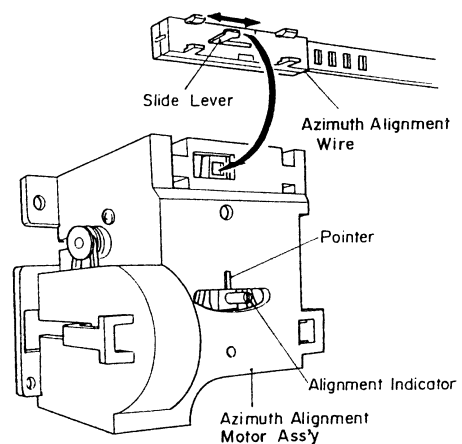

Fig. 4.24

Auto Azimuth Alignment button light starts flashing and Azimuth Alignment operation begins.

Referring to Fig. 4.25, adjust VR507 on the Logic P.C.B. Ass'y so that the Alignment Indicator corresponds to the pointer of the Azimuth Alignment Motor Ass'y as shown in Fig. 4.23.

- (f) When the Auto Azimuth Alignment operation is completed, Auto Azimuth Alignment button light goes out, then Auto Calibration of Bias, Level and Equalization is automatically carried out.
- (g) After completion of the above Auto Calibration, tape is automatically rewound to "0000" and the Standby/Set button light is illuminated.

With pressing the Standby/Set button, press the Tape Memory button A, B, C, or D to store the information (Bias, Level and Equalization).

- (h) Set the Test Tone switch to 400 Hz, then turn the RH Height Gear until the outputs of both channels become maximum.
- (i) Feed in 15 kHz (-20 dB) and set the Test Tone switch to OFF, then set the N-1000ZXL in Record and Play mode.

Turn the RH Azimuth Alignment Screw until the outputs of both channels become maximum.

- (j) Repeat above steps (h) and (i) one or two times to obtain optimum performance.
- (k) Set the N-1000ZXL in Stop mode, then again set in Record and Pause mode.

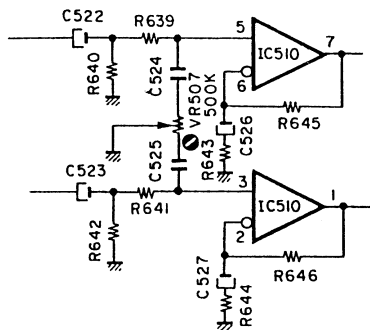

Fig. 4.25

- (l) With pressing the Auto Azimuth Alignment button "Azimuth", press the Play button to set the N-1000ZXL in Auto Azimuth Alignment mode.

Check to insure whether the Alignment Indicator corresponds to the pointer of the Azimuth Alignment Motor Ass'y in the position of VR507 as adjusted in above step (e). If not, re-adjust VR507 to correspond the Alignment Indicator to the pointer of the Azimuth Alignment Motor Ass'y.

- (m) Set the N-1000ZXL in Stop mode. Mount the Azimuth Alignment Wire on the Azimuth Alignment Motor Ass'y referring to Fig. 4.24. (Correct the position of the Slide Lever of the Azimuth Alignment Wire by sliding by hand, then insert the Slide Lever into the receptacle of the Azimuth Alignment Motor Ass'y.)

- (n) After completion of the above adjustment, record 400 Hz tone to the same portion of both sides A and B of the tape.

- (o) Immerse the recorded tape in a magnetized developing solution. In turn, check to insure that the recording head tracks across the center are separated with a distance of 0.55 to 0.75 mm (typically 0.65 mm) as illustrated in Fig. 4.26.

Note: Liquid for tape magnetized development solution

"MAGNA-SEE SOUND CRAFT a product of CBS RECORDS a division of Columbia Broadcasting System, Inc., Danbury, Conn. 06810 U.S.A., or equivalent".

After development, clean the tape otherwise pressure rollers and heads will become dirty.

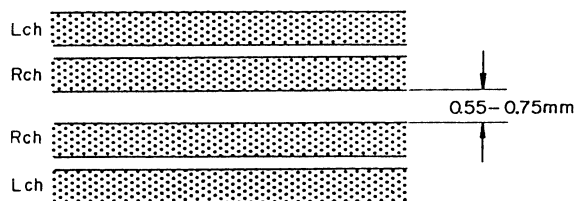

Typical: 0.65mm

Fig. 4.26

4.10. Record Head Stroke Adjustment

Refer to Figs. 4.27 and 4.28.

Note: This adjustment will be required only to insure freedom from misalignment of the record head stroke in the record head stroke check mode.

- (1) Check the accuracy of the record head stroke.
- (2) Remove Head Mount Base Ass'y referring to item 2.25.
- (3) Remove the record head assembly.
- (4) Adjustment of Record Head Mounting Gauge M-9048 (DA09048A)
 - (a) Mount the Block B onto the Mounting Gauge Plate.
 - (b) Loosen the 2 screws fixing the Block A.
 - (c) As shown in Fig. 4.27 hold the Gauges (3.05 mm and 0.1 mm thickness) between the Block A and Block B, fix the Block A with screws, pushing the Block A to the 2 guide pins.
- (5) Remove the Block B from the Mounting Gauge Plate.
- (6) As shown in Fig. 4.28, mount the R-8L record head assembly onto the Mounting Gauge Plate, then check the location of the R-8L record head surface. (If record head contacts to the Block C, loosen 2 pcs. of screws that are assembled record head and R-8L record head assembly, then place the R-8L record head assembly onto the Plate.)
- (7) Remove the R-8L record head assembly from the Mounting Gauge Plate.
- (8) Readjustment of Record Head Mounting Gauge M-9048 (DA09048A)
 - (a) Mount the Block B onto the Mounting Gauge Plate.
 - (b) Loosen the 2 screws fixing the Block A.
 - (c) As shown in Fig. 4.27 hold the Gauges (3.05 mm and either one of 0.05, 0.15, 0.2, 0.25, 0.3 or 0.35 mm thickness) between the Block A and Block B, fix the Block A with screw, pushing the Block A to the 2 guide pins.
- (9) Remove the Block B from the Mounting Gauge Plate.
- (10) Mount the R-8L record head assembly onto the Mounting Gauge Plate.
- (11) As shown in the Fig. 4.28, loosen the R-8L record head with 2 pcs. of screws onto the record head plate. As the location of the Block A is secured by the item (8)-(c), push the record head to the directions A and B, then tighten 2 pcs. of screws.
- (12) Check to insure freedom from gap between the Block C and record head surface, then tighten the 2 pcs. of screws on the record head plate with lock tight paint.
- (13) Assemble the record head assembly to the head mount base assembly.
- (14) Assemble the head mount base assembly to the mechanism assembly.
- (15) Check the record head stroke.

If the above are inaccurate, items (1) through (15) will have to be repeated till satisfactory results are obtained.

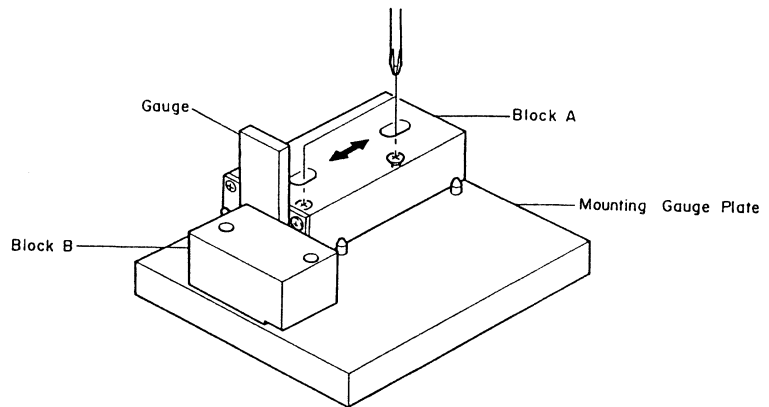
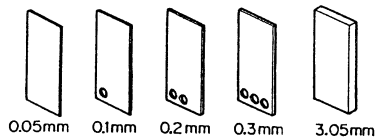

Fig. 4.27

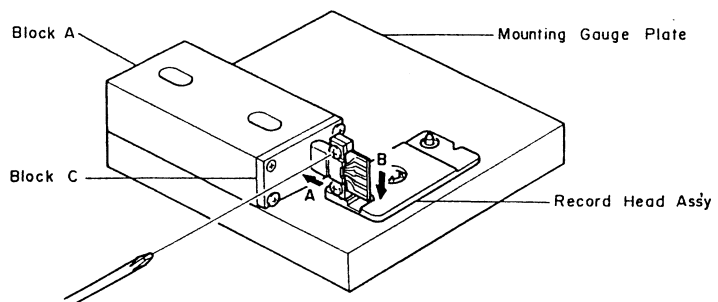

Fig. 4.28

4.11. Tape Travelling Adjustment

The adjustment shall be made with a modified version of the current type EX11 C-90 as shown in Fig. 4.29 (error will be made if a current type Tape Travelling Cassette (DA09011A) should be used for this purpose).

While modifying an EX11 C-90, the tape guides in the cassette housing shall be kept protected to avoid tilt. Check shall be made in the following procedures:

- (1) An EX11 C-90 Tape thus modified shall be loaded onto the N-1000ZXL.
- (2) Release the back-tension (rotate the Supply Reel and feed out some length of tape) and set the N-1000ZXL in Play mode.
- (3) In this juncture, check to insure whether the tape is free from waving or slippage from the tape guide.
- (4) When the modified EX11 C-90 is played back, check to insure whether the tape is freedom from waving from head surface or at pressure rollers.
- (5) If either of waving or slippage from the tape guide should be noted, adjustments of "4.4. Record Head and Playback Head Tilt Adjustment", "4.5. Head Base Stroke Adjustment", "4.6. Tape Guides Adjustment and Erase Head Stroke Adjustment", "4.7. Erase Head Height and Tilt Adjustment", "4.8. Back Tension Adjustment", "4.9. Playback Head and Record Head Height Adjustment and Azimuth Alignment", "4.10. Record Head Stroke Adjustment", etc. will be required.

As a case may be, the said waving or slippage may have been caused from defective Supply Pressure Roller Ass'y or Take-up Pressure Roller Ass'y without parallel contact with capstans. If such is noted, the Pressure Roller Assemblies will have to be replaced.

Further, excessively weak take-up torque or strong take-up torque may cause defective tape travelling.

The N-1000ZXL is intended to be an adjustment-free Model, however if the similar matters as above should be noted, please replace the Reel Hub Ass'y to obtain appropriate take-up torque.

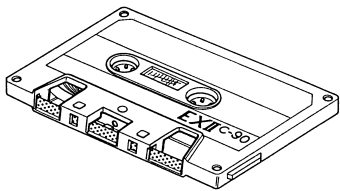

Fig. 4.29

4.12. Flywheel Holder Adjustment

- (1) Refer to Fig. 4.30.

Tighten the Thrust Screws until the gap between the Flywheel Assemblies and Thrust Screws becomes minimized when both of the Capstan Shafts are moved backwardly and forwardly (the Thrust Springs between the Capstan Flanges and Flywheel Thrust Caps are in a flat state).

Excessive tightening of the Thrust Screws however will give damages on the Flywheel Assemblies, to which careful attention is invited.

- (2) Return the Thrust Screws by 1/2 turn.
- (3) Fixing the Thrust Screw with a screwdriver, lock the Lock Nut.
- (4) Apply a quantity of lock tight paint to the Thrust Screws.

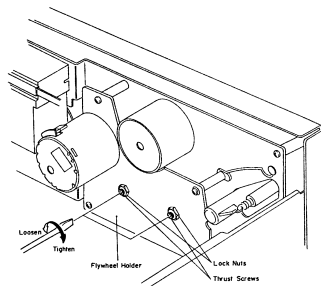

Fig. 4.30

4.13. Tape Speed Adjustment

- (a) Remove the Cabinet Ass'y.
- (b) Remove the CPU P.C.B. Ass'y.
- (c) Connect a Frequency Counter to Line Output Jacks.
- (d) Load a 3 kHz Speed Wow/Flutter Tape (DA09006A) and play it back.
- (e) Referring to Fig. 4.31, adjust the Tape Speed Adjustment Volume VR501 on the Speed Cal. P.C.B. Ass'y to obtain 3,000 Hz on the Frequency Counter.

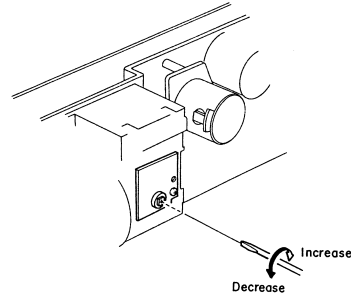

Fig. 4.31

4.14. Lubrication

N-1000ZXL is a lubrication-free cassette deck except when parts are replaced. Apply the following lubricant for each replaced part:

- (1) LAUNA #100
Capstan Shaft
Pressure Roller Shaft
Thrust Cap
- (2) FLOIL GB-TS-1
Reel Hub Shaft
Thrust portion on the Capstan Shaft
FLOIL GB-TS-1, made by Kanto Chemicals Co., Ltd., in Japan.
We suggest that you use the above or equivalent type. If unavailable please contact Kanto Chemicals Co., Ltd., 2-7 Kanda Suda-cho Chiyoda-ku, Tokyo 101 Japan.
- (3) Silicon Oil #3000CST
Air Damper Piston

Note: Excessive lubrication may cause defective damper action as the 0.2φ hole at the end of the cylinder may be filled with oil.

1000ZXL

5. PARTS LOCATION FOR ELECTRICAL ADJUSTMENT

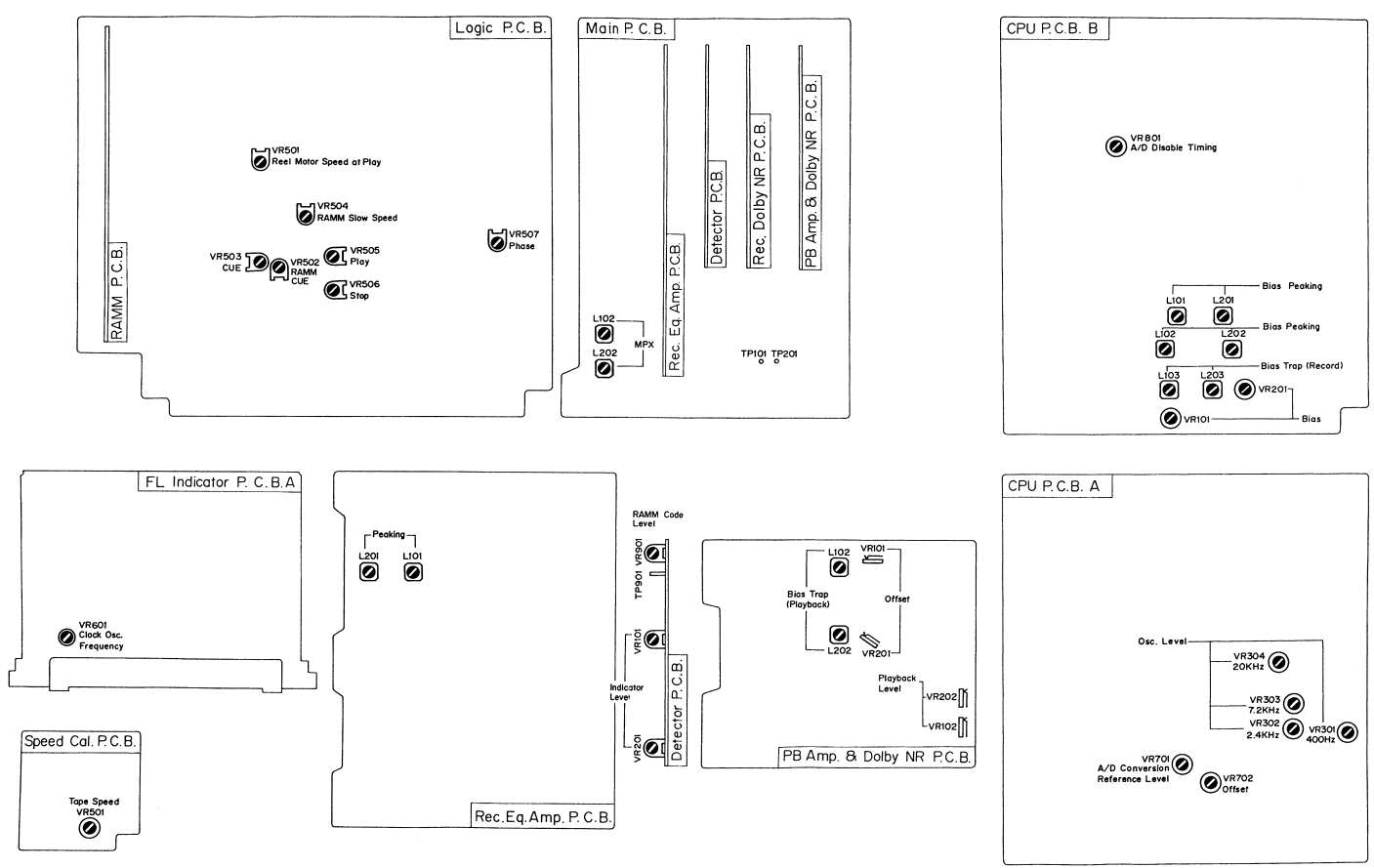

Fig. 5

6. ELECTRICAL ADJUSTMENTS AND MEASUREMENTS

6.1. Introduction

The N-1000ZXL incorporates a micro-processor which automatically calibrates the bias, level (sensitivity) and recording equalization to achieve an accurate frequency response of 20 Hz – 20 kHz when the auto calibration function is commanded.

To adjust the following steps manually, it is necessary to put the circuit to the desired adjustment condition.

The Test Unit is used for this purpose. Connect this unit with the N-1000ZXL and adjust manually the N-1000ZXL.

- Step 10: Maximum Bias Current Adjustment
- Step 11: Bias Trap (Record) Adjustment
- Step 12: Bias Current Adjustment
- Step 13: Oscillator Level Adjustment
- Step 14: A/D Converter Offset Adjustment
- Step 15: A/D Converter Frequency Response and Level Change Measurement

(1) How To Connect the Test Unit

(a) Remove the CPU P.C.B. Shield Plate referring to item 2.3-(3) on page 5, then unfasten 3 screws and turn over the CPU P.C.B. Ass'y referring to item 2.3-(4).

Thus, the CPU P.C.B. A Ass'y in the bottom of the CPU P.C.B. Ass'y becomes accessible.

(b) Connect the connectors CN-4, 5, 6, 7, 8 and 9 of the Test Unit to the test connectors CN-4, 5, 6, 7, 8 and 9 of the CPU P.C.B. A Ass'y respectively.

(c) When adjustments are completed, disassemble the Test Unit by reversing the above steps.

(2) How To Perform Switch Command

The Test Unit has 27 switches, SW1 – SW27. Preset switches SW3 – SW27 are of ON-OFF type, and Trigger switches SW1 and SW2 are of momentary type. Preset switches SW3 – SW24 are connected to the output ports and bidirectional ports of the micro-processor and a necessary command is set by the ON/OFF of SW3 – SW24. When the Trigger switch SW1 or SW2 is pressed, the command made by SW3 – SW24 is transmitted to the N-1000ZXL and the circuit of the N-1000ZXL is set in the required condition.

Table 6.1 shows the adjustment and the required switch condition of SW1 – SW24.

(3) How To Read LED Display

On step 13 "Oscillator Level Adjustment", the data of LEDs is used for adjustment. Each LED corresponds to the binary bit 2^7 , 2^6 , 2^5 , 2^4 , 2^3 , 2^2 , 2^1 and 2^0 . Accordingly, when the LEDs display as follows, the binary data is defined to be 11001100.

(example)

LED: 2^7 (ON) 2^6 (ON) 2^5 (OFF) 2^4 (OFF) 2^3 (ON) 2^2 (ON) 2^1 (OFF) 2^0 (OFF)

Binary Data: 11001100 (Hexadecimal Data: CC)

In the adjustment, the subtraction of the fixed binary data 00010000 from the "Reference Level" data is required.

In this case, refer to the following examples (binary subtraction) and find the solution.

(example)

$$\begin{array}{r}
 \text{Reference Level: } 11001001 \text{ (C9)} \\
 \text{Fixed Data: } \quad \quad \quad -00010000 \text{ (10)} \\
 \hline
 \text{Subtracted Solution: } 10111001 \text{ (B9)} \\
 \hline
 \begin{array}{r}
 1 \quad 1 \quad 10 \quad 100 \\
 -0 \quad -1 \quad -01 \quad -001 \\
 \hline
 1 \quad 0 \quad 01 \quad 011
 \end{array}
 \end{array}$$

Note: The data of the lowest bit is very small with respect to the whole data, therefore it can be neglected.

Table 6.1

ITEM	PRESET SW																TRIGGER SW		REMARKS						
	3	4	5	6	7	8	9	10	11	12	13	14	15	16	17	18	19	20		21	22	23	24	1	2
Step 10: Maximum Bias Current Adjustment	0	1	0	0	0	0	0	1	0	0	0	0	0	0	0	0	0	0	0	0	0	0	0	1	} Bias Osc.
	0	1	0	1	0	0	0	1	0	0	0	0	0	0	0	0	0	0	0	0	0	0	0	1	
Step 11: Bias Trap Adjustment (Record)	0	1	0	0	0	0	0	1	0	0	0	0	0	0	0	0	0	0	0	0	0	0	0	1	} Bias Osc.
	0	1	0	1	0	0	0	1	0	0	0	0	0	0	0	0	0	0	0	0	0	0	0	1	
Step 12: Bias Current Adjustment	1	0	0	0	0	0	0	1	1	1	1	0	0	0	0	0	0	0	0	0	0	0	0	1	} Bias Current
	1	0	0	1	0	0	0	1	1	1	1	0	0	0	0	0	0	0	0	0	0	0	0	1	
	0	1	0	1	0	0	0	1	1	1	1	0	0	0	0	0	0	0	0	0	0	0	0	1	
Step 13: Oscillator Level Adjustment	0	0	0	0	0	1	0	1	0	0	0	0	0	0	0	0	0	0	0	0	0	0	1	0	Auto Eq.
	0	0	0	0	1	0	0	0	0	1	0	0	0	0	0	0	0	0	0	0	0	0	1	0	400 Hz 0 dB
	0	0	0	0	0	1	0	0	0	1	0	0	0	0	0	0	0	0	0	0	0	0	1	0	400 Hz -10 dB
	0	0	0	0	0	0	1	0	1	1	1	0	0	0	0	0	0	0	0	0	0	0	1	0	400 Hz -30 dB
	0	0	0	0	1	0	0	0	0	1	0	0	0	0	0	0	0	0	0	0	0	0	1	0	2.4 kHz -30 dB
	0	0	0	0	1	0	0	0	1	0	0	0	0	0	0	0	0	0	0	0	0	0	1	0	7.2 kHz -30 dB
Step 14: A/D Converter Offset Adjustment	0	0	0	0	0	0	0	1	0	0	0	0	0	1	1	1	1	1	1	1	1	1	0	0	Offset Voltage
	0	0	0	0	0	0	1	1	0	0	0	0	0	0	0	0	0	0	0	0	0	0	1	0	8V -10 dB
Step 15: A/D Converter Frequency Response and Level Change Measurement	0	0	0	0	0	0	1	0	0	0	0	0	0	0	0	0	0	0	0	0	0	0	1	0	5V -10 dB
	0	0	0	0	0	1	1	0	1	1	0	0	0	0	0	0	0	0	0	0	0	0	1	0	8V -30 dB

Note: SW3 – SW24: "1" – ON, "0" – OFF
SW1 and SW2: "1" – pressed, "0" – not pressed

6.2. Adjustment and Measurement Instructions

Note: Electrical adjustment should be performed after the mechanical adjustment is completed.

STEP	ITEM	SIGNAL SOURCE	OUTPUT CONNECTION	MODE	ADJUSTMENT	REMARKS
1	Tape Speed Adjustment	3 kHz Speed and Wow/Flutter Tape (DA09006A)	Frequency Counter to Line Output Jacks	Playback	Speed Cal. P.C.B. VR501	Adjust VR501 to obtain 3 kHz $\pm 0.5\%$ on the frequency counter.
2	Playback Amp. Offset Adjustment	None	DC Voltmeter to Pin Nos. 1 and 7 of IC301 on Playback Amp. & Dolby NR P.C.B.	Stop	Playback Amp. & Dolby NR P.C.B. VR101, VR201	Adjust VR101 (VR201) to obtain DC 100 mV or less on the DC voltmeter.
3	Bias Trap Adjustment (Playback)	None	VTVM to Line Output Jacks	Record, Playback Monitor SW – Tape Eq. SW – 70 μ s Noise Reduction SW – OUT Filter SW – OFF	Playback Amp. & Dolby NR P.C.B. L102, L202	<ol style="list-style-type: none"> To allow the adjustment of L102 (L202), remove the Playback Amp. & Dolby NR P.C.B. Ass'y from the Main P.C.B., then connect them by an Extension Card M-9058 (DA09058A). Load a reference SX tape (DA09025A), then perform the auto calibration function as follows: <ol style="list-style-type: none"> Press the Record and Pause buttons. Pressing the Auto Calibration button "RUN", press the Play button. Load a blank tape, then press the Record and Play buttons to set in record and play mode. Adjust L102 (L202) to obtain a minimum reading on the VTVM. After completion of above adjustment, assemble the Playback Amp. & Dolby NR P.C.B. Ass'y.
4	FL Indicator Level and Dynamic Range Adjustment	400 Hz (0dB/-20 dB) to Line Input Jacks	Frequency Counter to Pin No. 7 of IC605 on FL Indicator P.C.B. A and VTVM to TP101, TP201 on Main P.C.B.	Monitor SW – Source Test Tone – 400 Hz/OFF Meter SW – P. Hold or VU/Peak	Indicator P.C.B. A VR601 Detector P.C.B. VR101, VR201	<ol style="list-style-type: none"> Remove the FL Indicator Ass'y from the Front Chassis and disassemble the FL Indicator Case Cover referring to item 2.15. Adjust VR601 to obtain 40.44 kHz clock on the frequency counter. Adjust the Line Input level controls to obtain 90 mV on the VTVM. Adjust VR101 (VR201) to obtain 0 dB on the FL level indicator. Decrease the line input signal levels by 20 dB, then check whether the FL level indicators indicate -20 dB. If not, finely adjust VR601 so that the FL level indicators indicate -20 dB. Repeat 3 – 5 till satisfactory results are obtained. Assemble the FL Indicator Ass'y. Set the Test Tone Switch to 400 Hz, then check whether the FL indicators indicate 0 dB. If not, adjust VR101 (VR201) to obtain 0 dB on the FL level indicators.
5	MPX Filter Adjustment	19 kHz ± 100 Hz to Line Input Jacks	VTVM to Line Output Jacks	Monitor SW – Source Meter SW – P. Hold or VU/Peak Filter SW – MPX	Main P.C.B. L102, L202	<ol style="list-style-type: none"> Set the Output level controls to max. Adjust the Line Input level controls to obtain 1 V on the VTVM. Set the Filter switch to MPX, then adjust L102 (L202) to obtain a minimum reading on the VTVM (the minimum reading will be less than -30 dB).
6	Playback Head Track Alignment	1 kHz Track Alignment Tape (DA09007A)	VTVM to Line Output Jacks	Playback Monitor SW – Tape Meter SW – P. Hold or VU/Peak Eq. SW – 70 μ s Noise Reduction SW – OUT Filter SW – OFF	PH Height Gear	<ol style="list-style-type: none"> Press the Manual Set button. Adjust the PH Height Gear to obtain minimum readings of both channels on the VTVM. Refer to "Playback Head Height Adjustment and Azimuth Alignment" in item 4.9.

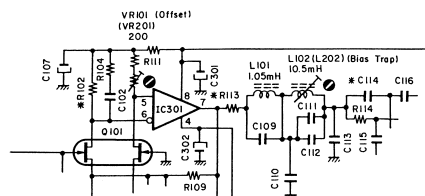

Fig. 6.2.1
2. Playback Amp. Offset
3. Bias Trap (Playback)

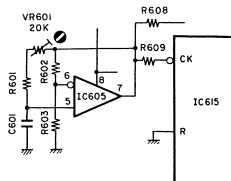

Fig. 6.2.2
4. FL Indicator Level and Dynamic Range

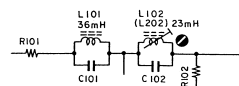
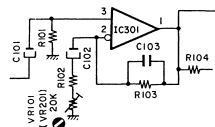

Fig. 6.2.3
5. MPX Filter

STEP	ITEM	SIGNAL SOURCE	OUTPUT CONNECTION	MODE	ADJUSTMENT	REMARKS
7	Playback Head Azimuth Alignment	15 kHz Azimuth Tape (DA09004A)	VTVM to Line Output Jacks	Playback Monitor SW – Tape Meter SW – P. Hold or VU/Peak Eq. SW – 70 μs Noise Reduction SW – OUT Filter SW – OFF	Playback Head Azimuth Alignment Screw	<ol style="list-style-type: none"> 1. Press the Manual Set button. 2. Adjust the Playback Head Azimuth Alignment screw to obtain the maximum readings of both channels on the VTVM. Refer to "Playback Head Height Adjustment and Azimuth Alignment" in Item 4.9. 3. Repeat above steps 6 and 7 one or two times to obtain optimum performance.
8	Playback Level Adjustment	400 Hz Level Tape (DA09005A)	VTVM to TP101, TP201 on Main P.C.B.	Same as above	Playback Amp. & Dolby NR P.C.B. VR102, VR202	<ol style="list-style-type: none"> 1. Press the Manual Set button. 2. Adjust VR102 (VR202) to obtain 90 mV on the VTVM or 0 dB on the FL level indicator.
9	Playback Frequency Response Adjustment	400 Hz Level Tape (DA09005A) 10 kHz PB Frequency Response Tape (DA09003A) 15 kHz PB Frequency Response Tape (DA09002A) 20 kHz PB Frequency Response Tape (DA09001A)	VTVM to Line Output Jacks	Same as above		<ol style="list-style-type: none"> 1. Press the Manual Set button. 2. Load a 400 Hz level tape and play it back. Set the Output level controls to a certain level (0 dB for example). 3. Load 10 kHz, 15 kHz and 20 kHz PB frequency response tapes, then adjust the playback head azimuth to give maximum levels on the VTVM with each tape. 4. Read the maximum levels with each tape and check to insure that the levels against the 400 Hz level tape are within the following ranges. 10 kHz: -20 dB -1 dB to +2 dB 15 kHz: -20 dB -1 dB to +2 dB 20 kHz: -20 dB -1 dB to +2 dB 5. Conduct step 7 "Playback Head Azimuth Alignment". 6. If above is not sufficient, refer to "Playback Frequency Response Adjustment" in Item 6.3.
10	Maximum Bias Current Adjustment	None	VTVM across R125, R225 (CN-19-1, -3) on CPU P.C.B. B	Record, Pause Bias Bit – 10000000	CPU P.C.B. B L101, L201 L102, L202	<ol style="list-style-type: none"> 1. Connect the Test Unit with the CPU P.C.B. A Ass'y referring to item 6.1. 2. Perform the following procedures on the Test Unit, thus the bias bits of both channels are set to 10000000. (Refer to table 6.1.) <ol style="list-style-type: none"> a. Set SW10 to ON. b. Set SW4 to ON, then press the Trigger SW2. c. Set SW4, 6 to ON, then press the Trigger SW2. Note: Switch is OFF unless otherwise specified as ON. 3. Adjust L101 (L201) and L102 (L202) to obtain the maximum reading on the VTVM.
11	Bias Trap Adjustment (Record)	None	VTVM to terminals BM1, BM2 on CPU P.C.B. B	Record, Pause Bias Bit – 10000000	CPU P.C.B. B L103, L203	<ol style="list-style-type: none"> 1. Connect the Test Unit with the CPU P.C.B. A Ass'y referring to item 6.1. 2. Perform the following procedures on the Test Unit, thus the bias bits of both channels are set to 10000000. <ol style="list-style-type: none"> a. Set SW10 to ON. b. Set SW4 to ON, then press the Trigger SW2. c. Set SW4, 6 to ON, then press the Trigger SW2. 3. Adjust L103 (L203) to obtain a minimum reading on the VTVM.

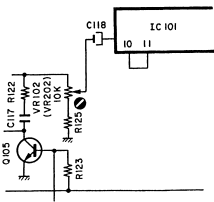

Fig. 6.2.4
8. Playback Level

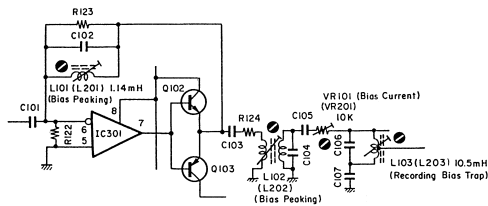

Fig. 6.2.5
10. Maximum Bias Current
11. Bias Trap (Record)

STEP	ITEM	SIGNAL SOURCE	OUTPUT CONNECTION	MODE	ADJUSTMENT	REMARKS
12	Bias Current Adjustment	None	VTVM across R125, R225 (CN-19-1, -3) on CPU P.C.B. B	Record, Pause Bias Bit – 11111111	CPU P.C.B. B VR101, VR201	<ol style="list-style-type: none"> Connect the Test Unit with the CPU P.C.B. A Ass'y referring to item 6.1. Perform the following procedures on the Test Unit, thus the bias bits of both channels are set to 11111111. <ol style="list-style-type: none"> Set SW10, 11, 12 and 13 to ON. Set SW3 to ON, then press the Trigger SW2. Set SW3, 6 to ON, then press the Trigger SW2. Set SW4 to ON, then press the Trigger SW2. Set SW4, 6 to ON, then press the Trigger SW2. Adjust VR101 (VR201) to obtain 80 mV on the VTVM.
13	Oscillator Level Adjustment	None	VTVM to TP101, TP201 on Main P.C.B.	Record, Pause	CPU P.C.B. A VR301 VR302 VR303 VR304 VR701	<ol style="list-style-type: none"> Connect the Test Unit with the CPU P.C.B. A Ass'y referring to item 6.1. Remove the Playback Amp. & Dolby NR P.C.B. Ass'y from the Main P.C.B. Ass'y referring to item 2.7, then connect the pin Nos. 4 (L ch.) and 5 (R ch.) of CN-47 on the Main P.C.B. Ass'y to the pin Nos. 3 (L ch.) and 5 (R ch.) of CN-49 on the Main P.C.B. Ass'y by jumper wires by soldering. Adjustment of 400 Hz –10 dB oscillation level: <ol style="list-style-type: none"> Perform the following procedures on the Test Unit. <ol style="list-style-type: none"> Set SW8, 10 to ON, then press the Trigger SW1 (Auto Eq.). Set SW7, 13 to ON, then press the Trigger SW1 (400 Hz 0 dB). Set SW9, 13 to ON, then press the Trigger SW1 (400 Hz –10 dB). Adjust VR301 to obtain 28.5 mV on the VTVM. Adjust VR701 so that the LEDs of the Test Unit display as follows: LED: 2⁷(ON) 2⁶(ON) 2⁵(OFF) 2⁴(OFF) 2³(ON) 2²(ON) 2¹(OFF) 2⁰(OFF) Binary: 11001100 Repeat to set SW14 to ON and OFF two or three times to insure that the display is fixed and unchangeable on OFF. Determination of the "Reference Level": <ol style="list-style-type: none"> Perform the following procedure on the Test Unit. <ol style="list-style-type: none"> Set SW9, 10, 12 and 13 to ON, then press the Trigger SW1 (400 Hz –30 dB). Repeat to set SW14 to ON and OFF two or three times to insure that the display is fixed and unchangeable on OFF. Note the value of 8 LEDs' display. This certain value is determined as the "Reference Level". Adjustment of 2.4 kHz –30 dB oscillation level: <ol style="list-style-type: none"> Perform the following procedure on the Test Unit. <ol style="list-style-type: none"> Set SW7, 12 to ON, then press the Trigger SW1 (2.4 kHz –30 dB). Adjust VR302 so that the LEDs' display meets the "Reference Level". Repeat to set SW14 to ON and OFF two or three times to insure that the display is fixed and unchangeable on OFF. Adjustment of 7.2 kHz –30 dB oscillation level: <ol style="list-style-type: none"> Perform the following procedure on the Test Unit. <ol style="list-style-type: none"> Set SW7, 11 to ON, then press the Trigger SW1 (7.2 kHz –30 dB). Adjust VR303 so that the LEDs' display meets the "Reference Level". Repeat to set SW14 to ON and OFF two or three times to insure that the display is fixed and unchangeable on OFF. Adjustment of 20 kHz –30 dB oscillation level: <ol style="list-style-type: none"> Perform the following procedure on the Test Unit. <ol style="list-style-type: none"> Set SW7, 10 to ON, then press the Trigger SW1 (20 kHz –30 dB). Adjust VR304 so that the LEDs' display shows less value than the "Reference Level" by 00010000. for example: Reference Level: 11001001 –00010000 LEDs' Display: 10111001 Repeat to set SW14 to ON and OFF two or three times to insure that the display is fixed and unchangeable on OFF. After completion of the above adjustment, disconnect the jumper wires between CN-47 and CN-49. And then assemble the Playback Amp. & Dolby NR P.C.B. Ass'y.

STEP	ITEM	SIGNAL SOURCE	OUTPUT CONNECTION	MODE	ADJUSTMENT	REMARKS
14	A/D Converter Offset Adjustment	None	DC Voltmeter to Pin No. 1 of IC713 on CPU P.C.B. A	Stop	CPU P.C.B. A VR702	<ol style="list-style-type: none"> 1. Connect the Test Unit with the CPU P.C.B. A Ass'y referring to item 6.1. 2. Perform the following procedure on the Test Unit. <ol style="list-style-type: none"> a. Set SW15, 16, 17, 18, 19, 20, 21, 22, 23 and 24 to ON (Offset Voltage). 3. Adjust VR702 to obtain a reading of 0 V ± 50 mV on the DC voltmeter. 4. After completion of above adjustment, set the switches to OFF.
15	A/D Converter Frequency Response Measurement and A/D Converter Level Change Measurement	400 Hz (-10 dB/-20 dB/-30 dB) and 20 kHz (-10 dB/-20 dB) to Line Input Jacks	VTVM to TP101 or TP201 on Main P.C.B. and DC Voltmeter to terminal CM8 on CPU P.C.B. A	Monitor SW - Source		<ol style="list-style-type: none"> 1. Connect the Test Unit with the CPU P.C.B. A Ass'y referring to item 6.1. 2. Remove the Playback Amp. & Dolby NR P.C.B. Ass'y from the Main P.C.B. Ass'y referring to item 2.7, then connect the pin Nos. 4 (L ch.) and 5 (R ch.) of CN-47 on the Main P.C.B. Ass'y to the pin Nos. 3 (L ch.) and 5 (R ch.) of CN-49 on the Main P.C.B. Ass'y by jumper wires by soldering. 3. Perform the following procedure on the Test Unit. <ol style="list-style-type: none"> a. Set SW9, 10 to ON, then press the Trigger SW1 (8 V -10 dB). 4. Feed in 400 Hz -10 dB to the Line Input jacks. 5. Adjust the Line Input level controls to obtain 28.5 mV on the VTVM and then check to insure that the reading is 7.6 V ± 1 V on the DC voltmeter. 6. Feed in 20 kHz -10 dB and check to insure that the reading is 7.2 V ± 1 V on the DC voltmeter. 7. Feed in 400 Hz -20 dB and 20 kHz -20 dB and then check that each reading is 2.4 V ± 0.4 V and 2.3 V ± 0.4 V on the DC voltmeter. 8. After completion of above frequency response check, perform the following procedure on the Test Unit for level change check. <ol style="list-style-type: none"> a. Set SW9 to ON, then press the Trigger SW1 (5 V -10 dB). 9. Feed in 400 Hz -10 dB to the Line Input jacks. Adjust the Line Input level controls to obtain 28.5 mV on the VTVM and then check to insure that the reading is 4.9 V ± 1 V on the DC voltmeter. 10. Perform the following procedure on the Test Unit. <ol style="list-style-type: none"> a. Set SW9, 10, 12 and 13 to ON, then press the Trigger SW1 (8 V -30 dB). 11. Feed in 400 Hz -30 dB to the Line Input jacks. Adjust the Line Input level controls to obtain 2.85 mV on the VTVM and then check to insure that the reading is 7.2 V ± 1 V on the DC voltmeter. 12. After completion of above measurement, disconnect the jumper wires between CN-47 and CN-49. And then assemble the Playback Amp. & Dolby NR P.C.B. Ass'y. 13. Remove the Test Unit from the CPU P.C.B. A Ass'y referring to item 6.1.

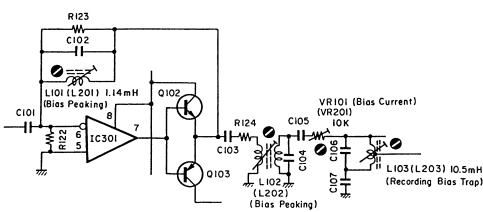

Fig. 6.2.6
12. Bias Current

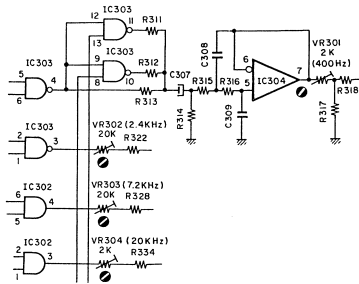

Fig. 6.2.7
13. Oscillator Level

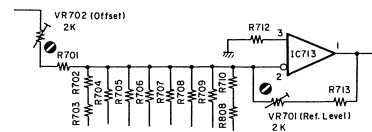

Fig. 6.2.8
14. A/D Converter Offset

STEP	ITEM	SIGNAL SOURCE	OUTPUT CONNECTION	MODE	ADJUSTMENT	REMARKS
16	Record Head Height Adjustment and Azimuth Alignment	Test Tone 400 Hz and 15 kHz -20 dB to Line Input Jacks	VTVM to Line Output Jacks	Record, Playback Monitor SW - Source Test Tone SW - 400 Hz/OFF Meter SW - P, Hold or VU/Peak Eq. SW - 70 μ s Noise Reduction SW - OUT Filter SW - OFF	Head Height: RH Height Gear Azimuth Alignment: Record Head Azimuth Alignment Screw Logic P.C.B. VR507	<ol style="list-style-type: none"> In stop mode, turn the Azimuth Motor by hand so that the Alignment Indicator corresponds to the pointer of the Azimuth Alignment Motor Ass'y as shown in Fig. 4.23. Remove the Azimuth Alignment wire by pulling out from the Azimuth Alignment Motor Ass'y. (In this case, do not move the Slide Lever of the Azimuth Alignment wire.) Load a reference SX tape (DA09025A), then perform the auto calibration function as follows: <ol style="list-style-type: none"> Press the Record and Pause buttons to set in Record/Pause mode. Pressing the Auto Calibration button "Run", press the Play button. Tape counter becomes "0000" and Auto Azimuth Alignment button light starts flashing. After disappearing flashing, Bias, Level and Eq. will go to performance automatically. The tape is rewound to "0000", the Standby/Set button light and the Manual Set button light come on, and the auto calibration function is completed. During the azimuth alignment operation in 2, adjust VR507 on the Logic P.C.B. so that the Alignment Indicator corresponds to the pointer of the Azimuth Alignment Motor Ass'y as shown in Fig. 4.23. Record Head Height Adjustment: <ol style="list-style-type: none"> Set the Test Tone switch to 400 Hz. Record signals on the reference SX tape (DA09025A), and then play it back. Adjust the RH Height Gear to obtain the maximum readings of both channels on the VTVM. Record Head Azimuth Alignment: <ol style="list-style-type: none"> Set the Test Tone switch to OFF, then feed in 15 kHz (-20 dB). Record signals on the reference SX tape (DA09025A) and then play it back. Adjust the Record Head Azimuth Alignment Screw to obtain the maximum readings of both channels on the VTVM. Repeat 4 and 5 one or two times to obtain optimum performance. Press the Stop button, then perform the auto azimuth alignment function as follows: <ol style="list-style-type: none"> Press the Record and Pause buttons. Pressing the Auto Azimuth Alignment button "Azimuth", press the Play button. The counter becomes "0000" and Auto Azimuth Alignment button light starts flashing. When alignment is completed, the button light goes out and the tape is automatically rewound to "0000". During the auto azimuth alignment operation in 6, check to insure whether the Alignment Indicator corresponds to the pointer of the Azimuth Alignment Motor Ass'y at the position of VR507 as adjusted in 3. If not, re-adjust VR507 to correspond the Alignment Indicator to the pointer of the Azimuth Alignment Motor Ass'y. Press the Stop button, then mount the Azimuth Alignment wire on the Azimuth Alignment Motor Ass'y referring to Fig. 4.24. Perform the auto calibration function referring to 2. During the auto azimuth alignment operation, check to insure that the Alignment Indicator corresponds to the pointer of the Azimuth Alignment Motor Ass'y. Feed in 15 kHz (-20 dB). Record signals on the reference SX tape (DA09025A) and then play it back. Check to insure that the playback level is the same as the source monitor level for both channels.
17	A/D Converter Disable Timing Adjustment	None	Synchroscope to Pin No. 4 of IC809 on CPU P.C.B. B	Stop	CPU P.C.B. B VR801	<ol style="list-style-type: none"> Set the vertical gain of the synchroscope to 5 V/cm. Perform the auto calibration function referring to step 16-2. During auto calibration operation, waveform in Fig. 6.2.10 is observed. Adjust VR801 so that the high-level period of the waveform becomes 450 ms.

STEP	ITEM	SIGNAL SOURCE	OUTPUT CONNECTION	MODE	ADJUSTMENT	REMARKS
18	Overall Frequency Response Adjustment	400 Hz (0 dB) and 20 Hz - 20 kHz (-20 dB) to Line Input Jacks	VTVM and Distortion Meter to Line Output Jacks	Record, Playback Monitor SW - Source/Tape Meter SW - P. Hold or VU/Peak Eq. SW - 120 μs (EX) 70 μs (SX/ZX) Noise Reduction SW - OUT Filter SW - OFF	Rec. Eq. Amp. P.C.B. L101, L201	For each tape to be used, perform the auto calibration function referring to step 16-2. 1. Set the Monitor switch to Source. 2. Feed in 400 Hz (0 dB), then adjust the Line Input level controls to obtain 0 dB on the FL level indicators. 3. Switch the generator output level to -20 dB. 4. Set the Monitor switch to Tape, then record and play it back. 5. Feed in 20 Hz - 20 kHz (-20 dB), then check to insure that the output levels are within -20 dB ±0.75 dB on the VTVM. 6. If above is not sufficient, adjust L101 (L201) to obtain -20 dB ±0.75 dB output level on the VTVM. 7. If a satisfactory result is not obtained, precise re-adjustment of step 9 "Playback Frequency Response", replacement of Playback Head or Record Head, check on item 4.11 "Tape Travelling Adjustment", or frequency adjustment according to item 6.3 will be required.
19	Crosstalk Measurement	1 kHz to Line Input Jacks	1 kHz Band Pass Filter and VTVM to Line Output Jacks	Record and Playback Monitor SW - Source/Tape Meter SW - P. Hold or VU/Peak Eq. SW - 70 μs Noise Reduction SW - OUT Filter SW - OFF		1. Erase a reference ZX tape (DA09037A) with a bulk eraser. 2. Load the tape, then perform the auto calibration function according to step 16-2. 3. Adjust the Line Input level controls to obtain 0 dB on the FL level indicators, then record the signals on the tape. 4. Turn the cassette tape the other way round and play it back. 5. Measure the difference between 3 and 4.
20	Channel Separation Measurement	1 kHz to Line Input Jacks	Same as above	Same as above		1. Erase a reference ZX tape (DA09037A) with a bulk eraser. 2. Load the tape, then perform the auto calibration function according to step 16-2. 3. Adjust the L ch. (R ch.) Line Input level control to obtain 0 dB on the FL level indicator, then close the R ch. (L ch.) Line Input level control. 4. Record and play it back, then measure the R ch. (L ch.) level.
21	Erasur Measurement	1 kHz to Line Input Jacks	Same as above	Same as above		1. Erase a reference ZX Tape (DA09037A) with a bulk eraser. 2. Load the tape, then perform the auto calibration function according to step 16-2. 3. Adjust the Line Input level controls to obtain 0 dB on the FL level indicators, then record the signals on the tape. 4. Rewind the tape then close the Line Input level controls. 5. Record and play it back, then measure the difference between 3 and 4.

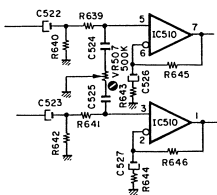

Fig. 6.2.9
16. Record Head Azimuth

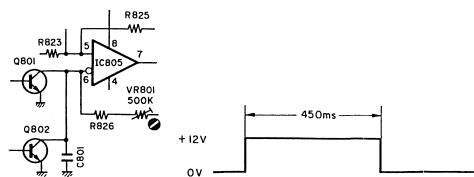

Fig. 6.2.10
17. A/D Converter Disable Timing

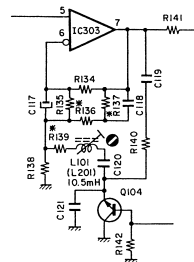

Fig. 6.2.11
18. Overall Frequency Response

STEP	ITEM	SIGNAL SOURCE	OUTPUT CONNECTION	MODE	ADJUSTMENT	REMARKS
22	Signal to Noise Ratio Measurement	400 Hz to Line Input Jacks	VTVM and Distortion Meter to Line Output Jacks	Record and Playback Monitor SW – Tape Meter SW – P. Hold or VU/Peak Eq. SW – 70 μ s Noise Reduction SW – Dolby NR Filter SW – OFF		1. Load a reference ZX tape (DA09037A), then perform the auto calibration function according to step 16-2. 2. Feed in 400 Hz (0 dB), then record and play it back. 3. Adjust the Line Input level controls to obtain 3% total harmonic distortion in Playback mode. 4. Close the Line Input level controls then record again. 5. After reword, play back and check the output level difference between 3 and 4. Note: The filter of IHF-A curve shall be used in the measurements.
23	Total Harmonic Distortion Measurement	400 Hz to Line Input Jacks	Distortion Meter to Line Output Jacks	Record and Playback Monitor SW – Source/Tape Meter SW – P. Hold or VU/Peak Eq. SW – 120 μ s (EX) 70 μ s (SX/ZX) Noise Reduction SW – OUT Filter SW – OFF		1. Load a reference ZX tape (DA09037A), then perform the auto calibration function according to step 16-2. 2. Set the Monitor switch to Source, then adjust the Line Input level controls to obtain 0 dB on the FL level indicators. 3. Set the Monitor switch to Tape, then record and play it back. 4. Read the distortion meter and check to insure that the distortion is less than 0.8% for ZX tape and 1.0% for SX and EXII tapes.
24	Subsonic Filter Measurement	10 Hz \pm 0.2 Hz to Line Input Jacks	VTVM to Line Output Jacks	Stop Monitor SW – Source Meter SW – P. Hold or VU/Peak Eq. SW – 70 μ s Noise Reduction SW – OUT Filter SW – OFF/Subsonic		1. Set the Output level controls to max. 2. Adjust the Line Input level controls to obtain 1V on the VTVM. 3. Set the Filter switch to Subsonic, then check to insure that the readings of both channels are less than -55 dB on the VTVM.
25	Wow/Flutter Measurement	3 kHz Speed and Wow/Flutter Tape (DA09006A)	Wow/Flutter Meter to Line Output Jacks	Playback Monitor SW – Tape Meter SW – P. Hold or VU/Peak Eq. SW – 70 μ s		1. Press the Manual Set button. 2. Play back and read the wow/flutter meter.

6.3. Frequency Response Adjustment

(1) **Playback Frequency Response Adjustment**
Refer to Figs. 6.3.1 and 6.3.2.

(a) **Level Adjustment (for middle frequency response)**

This adjustment will be required if playback level is not sufficient when 10 kHz PB frequency response tape is played back as referred to step 9 in 6.2 "Adjustment and Measurement Instructions". Playback equalization level is varied by the modification of R121 (R221) and R122 (R222) for 70 μ s equalization and R110 (R210) for 120 μ s equalization on the Playback Amp. & Dolby NR P.C.B. Ass'y. Following are the details for level modifications:

For 70 μ s:

Approx. +1 dB R121 (R221): 2.3K
R122 (R222): 3.51K
0 dB R121 (R221): 2.67K
R122 (R222): 3.16K
Approx. -1 dB R121 (R221): 3K
R122 (R222): 2.67K

For 120 μ s:

Approx. +1 dB R110 (R210): 16.2K
0 dB R110 (R210): 18K
Approx. -1 dB R110 (R210): 20.5K

(b) **Peaking Adjustment (for high frequency response)**

This adjustment will be required if playback level is not sufficient when 20 kHz PB frequency response tape is played back as referred to step 9 in "Adjustment and Measurement Instructions". Peaking portion compensates the gap loss of the playback head.

Peaking level is varied by the modification of R113 (R213) on the Playback Amp. & Dolby NR P.C.B. Ass'y as shown in Fig. 6.3.2. Typical value of R113 (R213) is 1 k Ω . The maximum and the minimum value of R113 (R213) should be 1.2 k Ω and 820 Ω .

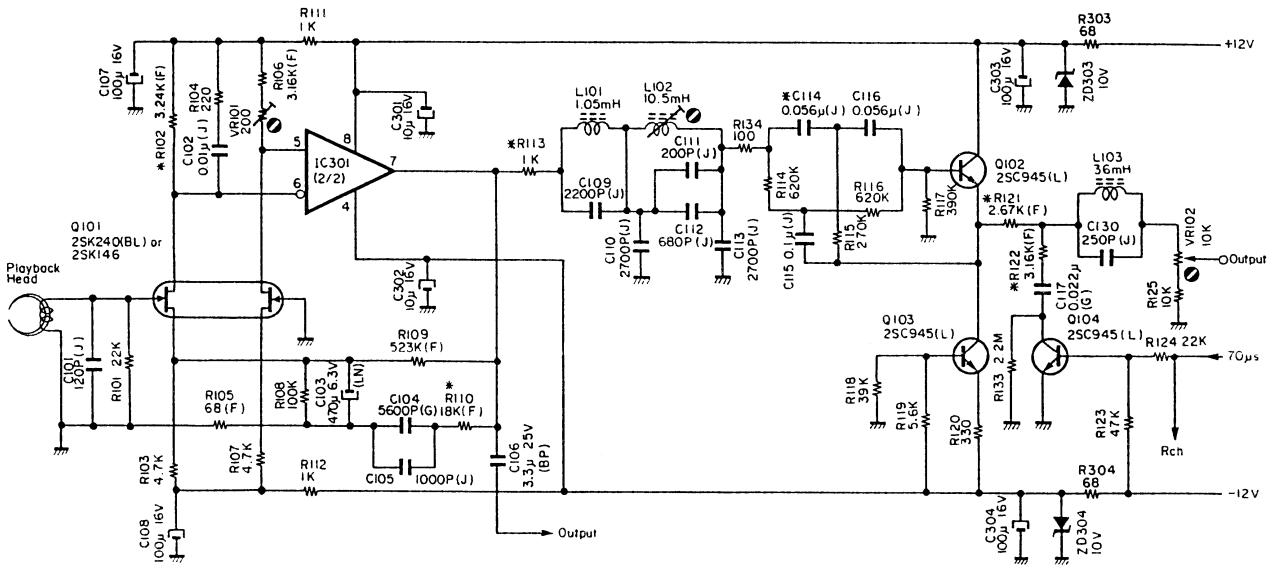

Fig. 6.3.1 Playback Amp.

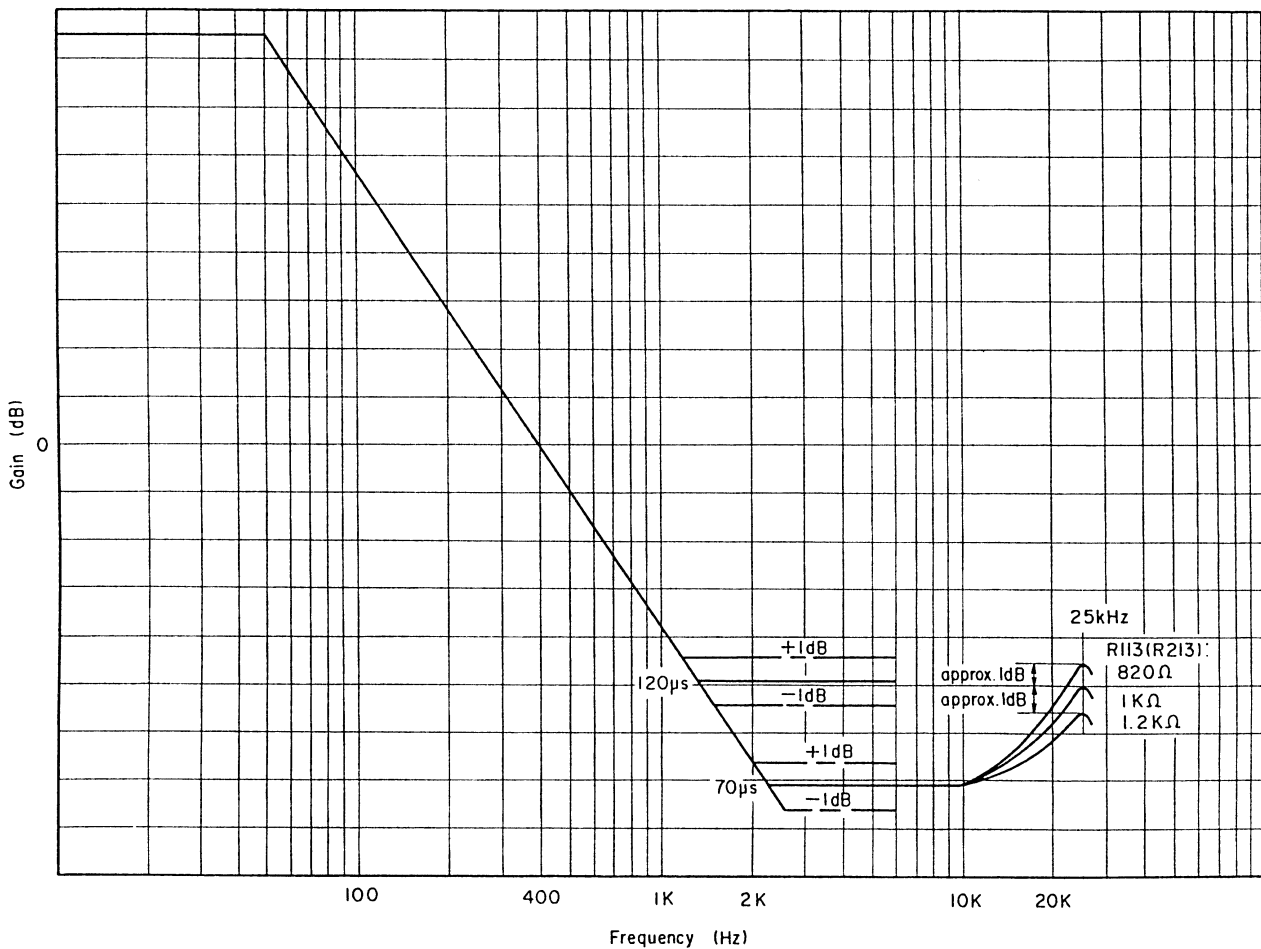

Fig. 6.3.2 Playback Equalization Curve

(2) Record Current Frequency Response

This adjustment will be made to compensate the overall frequency response after the playback frequency response adjustment is completed.

Before this adjustment, the following should be accurately adjusted.

- Oscillator level adjustment on step 13 in item 6.2
Each oscillator level of the 400 Hz -30 dB, 2.4 kHz -30 dB, 7.2 kHz -30 dB and 20 kHz -30 dB should be accurate.
- Record head azimuth alignment on step 16 in item 6.2
No misalignment is found when auto azimuth alignment function is completed.
- Tape travelling adjustment in item 4.11

Note: Cassette tape to be used for frequency response adjustment should satisfy the quality.

(a) High-frequency Response Adjustment

Refer to Figs. 6.3.3 – 6.3.6.

Figs. 6.3.3 and 6.3.4 show the record peaking curve. Peaking frequency is adjusted by the adjustment of L101 (L201) and the peaking level is changed by the modification of R139 (R239).

If the frequency response shows the solid line as shown in Fig. 6.3.5, change the value of the resistor R139 (R239) on the Record Eq. Amp. P.C.B. Ass'y from 820 Ω to 680 Ω.

If the dotted line, change it from 820 Ω to 1 kΩ.

- Notes:
1. Since the distortion is increased when the resistor R139 or R239 is changed to greater value, re-check the distortion after R139 or R239 is changed.
 2. The value of the R139 or R239 may be changed for adjustment in our factory.

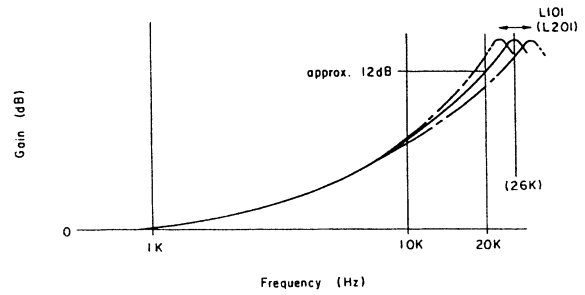

Fig. 6.3.3 Record Peaking Curve

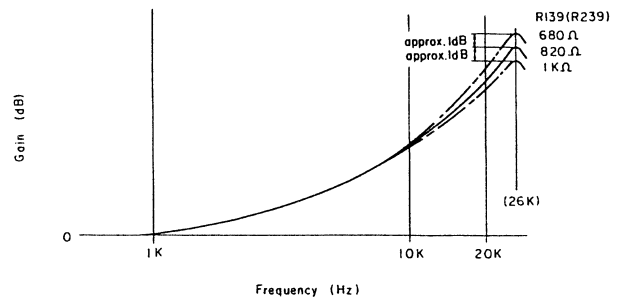

Fig. 6.3.4 Record Peaking Curve

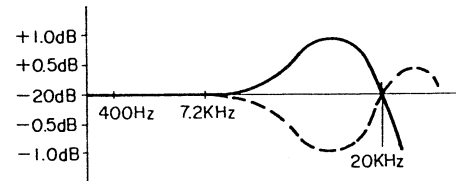

Fig. 6.3.5

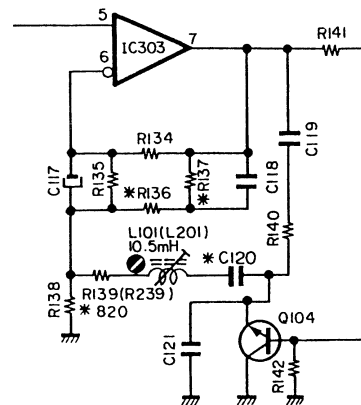

Fig. 6.3.6

(b) Low-frequency Response Adjustment

In general, the frequency response at low shows the response in Fig. 6.3.7. When the level at 400 Hz is considered to be 0 dB, the level at 20 Hz shows the minimum value (A) and the peak of the waveform produced by contour effect shows the maximum value (B). The peak of the waveform appears around the range of 40 – 80 Hz depending upon the playback head.

Adjustment procedures are as follows:

- Check the level difference between the level at 20 Hz (A) and the peak level (B) of the waveform. If the difference is greater than 1.5 dB, perform the following adjustment 1).
- If the frequency response at low is not within ± 0.75 dB with respect to the level at 400 Hz, even though the level difference is less than 1.5 dB, perform the following adjustment 2).

1) Peak-to-peak level adjustment

Adjust so that the level difference between (A) and (B) in Fig. 6.3.7 becomes less than 1.5 dB.

- a) Add capacitor C1 0.015 μ F in parallel to C114 (C214) on the Playback Amp. & Dolby NR P.C.B. Ass'y as shown in Fig. 6.3.8. This will compensate approx. 0.2 dB.
- b) If compensation is still insufficient, add resistor R1 2.2 M Ω – 560 k Ω in parallel to R136 (R236) on the Record Eq. Amp. P.C.B. Ass'y as shown in Fig. 6.3.9. When 560 k Ω is added, approx. 0.3 dB will be compensated.

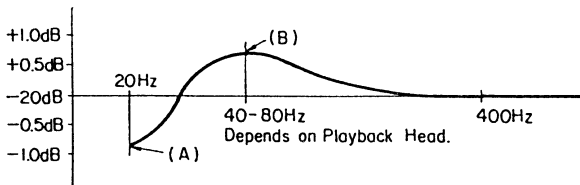

Fig. 6.3.7

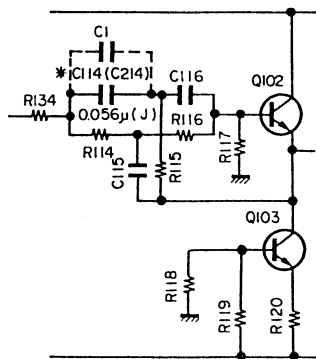

Fig. 6.3.8

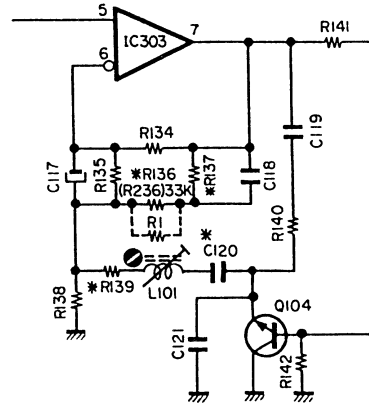

Fig. 6.3.9

2) Level Adjustment

Adjust so that the level differences between 400 Hz and 20 Hz (A) and between 400 Hz and the peak value (B) of the waveform become equal. Refer to Fig. 6.3.10.

a) Decreasing of level

Add resistor R2 in series with R136 (R236) on the Record Eq. Amp. P.C.B. Ass'y.

Additional R2	Decreased level
3.3 k Ω	0.5 dB
2.2 k Ω	0.35 dB
1 k Ω	0.15 dB

b) Increasing of Level

Add resistor R3 in parallel to R137 (R237) on the Record Eq. Amp. P.C.B. Ass'y.

Additional R3	Increased level
470 k Ω	0.5 dB
1 M Ω	0.2 dB

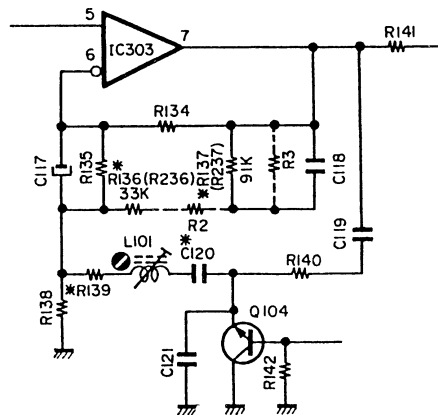

Fig. 6.3.10

6.4. Dolby NR Circuit Check

Dolby NR circuit incorporates a Dolby B-Type NR IC (μ A7300PC) which has no adjustment point.

Perform the following checks and make sure that the IC operates accurately i.e. accuracy of frequency response through IC.

(1) Playback Dolby NR Circuit

Signal Source: 5 kHz to pin No.12 of IC101 and IC201
 Output Connection: VTVM to the test points TP101 and TP201 on the Main P.C.B.
 Mode: Stop
 Monitor SW – Tape
 Noise Reduction SW – Out/Dolby NR

- (a) Connect a VTVM to TP101 (TP201) on the Main P.C.B.
 Feed in 5 kHz to pin No. 12 of IC101 (IC201) and adjust the generator output control so that the VTVM may read 7.6 mV at each test point.
- (b) Set the Noise Reduction switch to Dolby NR. Check to insure that the level at TP101 (TP201) is 3 mV \pm 1.5 dB.

(2) Record Dolby NR Circuit

Signal Source: 5 kHz to Line Input Jacks
 Output Connection: VTVM to the output side of C121 (C221) on the Record Dolby NR P.C.B.
 Mode: Stop
 Monitor SW – Source

- (a) Connect a VTVM to TP101 (TP201) on the Main P.C.B.
 Feed in 5 kHz and adjust the Line Input level controls so that the VTVM may read 100 mV (0 dB) at each test point.
 FL level indicators will indicate 0 dB.
- (b) Remove the VTVM from TP101 (TP201) and re-connect it to the output side of C121 (C221). Check to insure that the VTVM indicates approx. 560 mV.
- (c) Decrease the input level (0 dB) by 20 dB or 30 dB. Check to insure that the level at output side of C121 (C221) corresponds to the following with Noise Reduction switch Out (Dolby NR OUT) and Dolby NR (Dolby NR IN).

Input Level	Capacitor Output Level		
(f=5 kHz)	Dolby NR OUT	Dolby NR IN	Difference between IN and OUT
-20 dB	-20 dB	-16.8 dB \pm 1.5 dB	3.2 dB \pm 1.5 dB
-30 dB	-30 dB	-21.8 dB \pm 1.5 dB	8.2 dB \pm 1.5 dB

7. MOUNTING DIAGRAMS AND PARTS LIST

Note: Mounting diagram shows a dip side view of the printed circuit board.

7.1. Fuse P.C.B. Ass'y

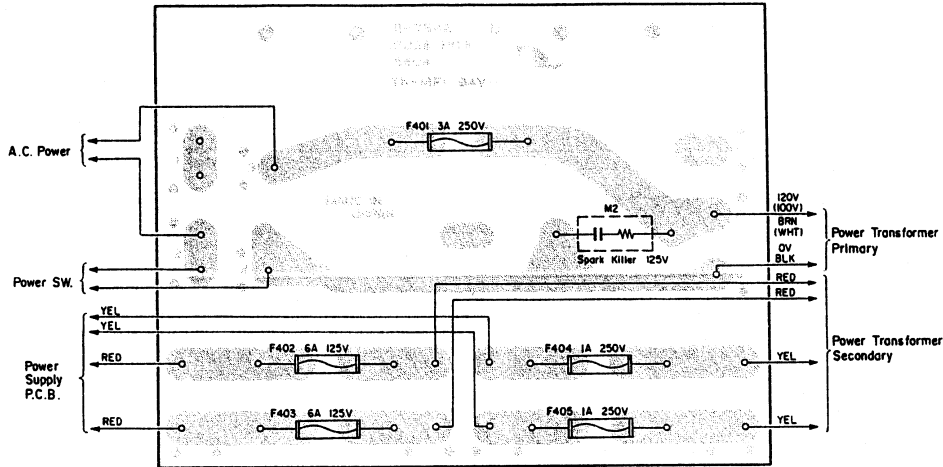

Fig. 7.1.1 U.S.A., Canada & Others

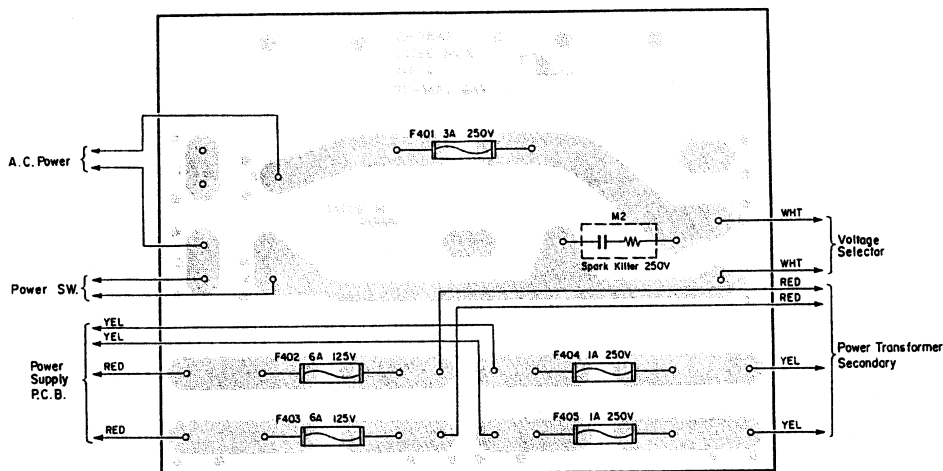

Fig. 7.1.2 Japan

Schematic Ref. No.	Part No.	Description	Schematic Ref. No.	Part No.	Description
	BA04256A	Fuse P.C.B. Ass'y (U.S.A., Canada & Others)		BA04257A	Fuse P.C.B. Ass'y (Japan)
F401	OB07842D	Fuse P.C.B.		OB07842D	Fuse P.C.B.
F402,403	OB08369A	Fuse 3A 250V	F401	OB08781A	Fuse 3A 250V
F404,405	OB08371A	Fuse 6A 125V	F402,403	OB08782A	Fuse 6A 125V
	OB08374A	Fuse 1A 250V	F404,405	OB08686A	Fuse 1A 250V
	OB08342A	Spark Killer (1 pce.)		OB08363A	Spark Killer (1 pce.)
	OM04187A	Fuse Label 3A 250V (1 pce.)		OM04187A	Fuse Label 3A 250V (1 pce.)
	OM04189A	Fuse Label 6Ax2 (1 pce.)		OM04189A	Fuse Label 6Ax2 (1 pce.)
	OM04078B	Fuse Label 1Ax2 (1 pce.)		OM04078B	Fuse Label 1Ax2 (1 pce.)
	OE00752A	Eyelet 2x3 (6 pcs.)		OE00752A	Eyelet 2x3 (6 pcs.)
				OB08349A	Fuse Clip (4 pcs.)

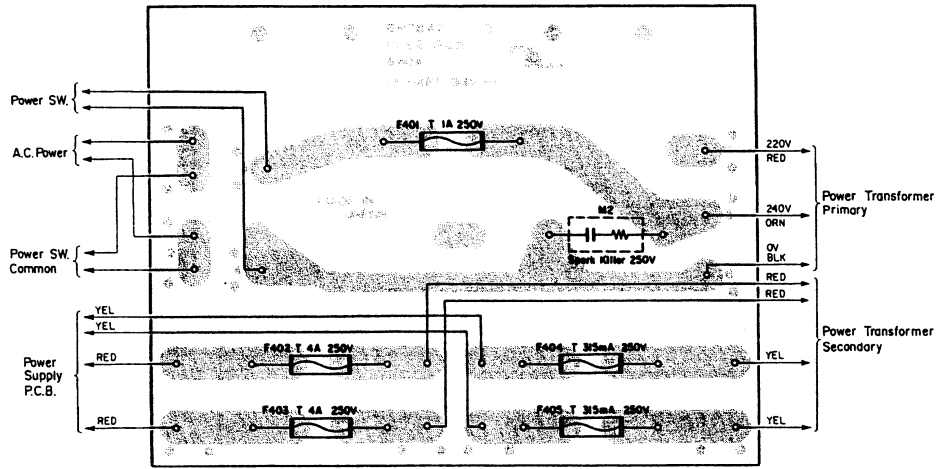

Fig. 7.1.3 UK & Australia

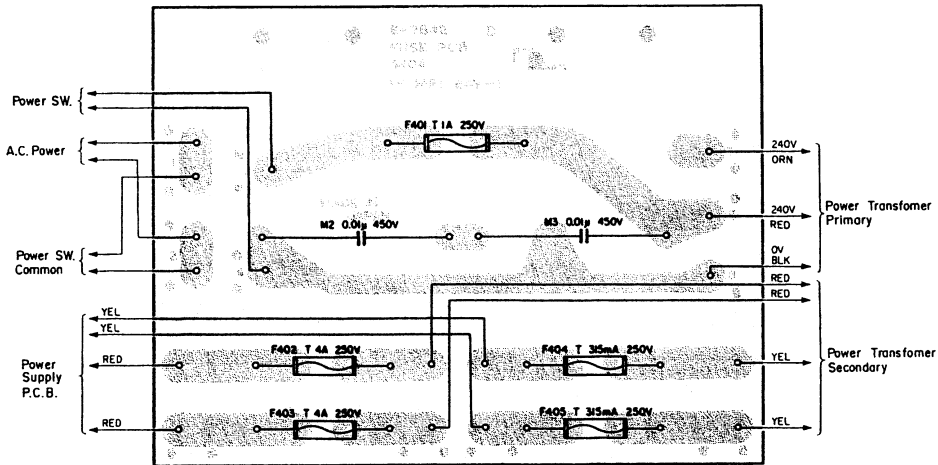

Fig. 7.1.4 220 V Class 2

Schematic Ref. No.	Part No.	Description	Schematic Ref. No.	Part No.	Description
	BA04258A	Fuse P.C.B. Ass'y (UK & Australia)		BA04259A	Fuse P.C.B. Ass'y (220V Class 2)
F401	0B07842D	Fuse P.C.B.	F401	0B07842D	Fuse P.C.B.
F402,403	0B08347U	Fuse T 1A 250V	F402,403	0B08347U	Fuse T 1A 250V
F404,405	0B08609A	Fuse T 4A 250V	F404,405	0B08609A	Fuse T 4A 250V
	0B08263U	Fuse T 315mA 250V		0B08263U	Fuse T 315mA 250V
	0B08240A	Spark Killer (1 pce.)		0B08445A	Spark Killer (2 pcs.)
	0M04191A	Fuse Label T 1A 250V (1 pce.)		0M04191A	Fuse Label T 1A 250V (1 pce.)
	0M04193A	Fuse Label T 4Ax2 (1 pce.)		0M04193A	Fuse Label T 4Ax2 (1 pce.)
	0M04074B	Fuse Label T 315mAx2 (1 pce.)		0M04074B	Fuse Label T 315mAx2 (1 pce.)
	0B08349A	Fuse Clip (10 pcs.)		0B08349A	Fuse Clip (10 pcs.)
	0E00752A	Eyelet 2x3 (6 pcs.)		0E00752A	Eyelet 2x3 (6 pcs.)

7.2. Power Supply P.C.B. Ass'y

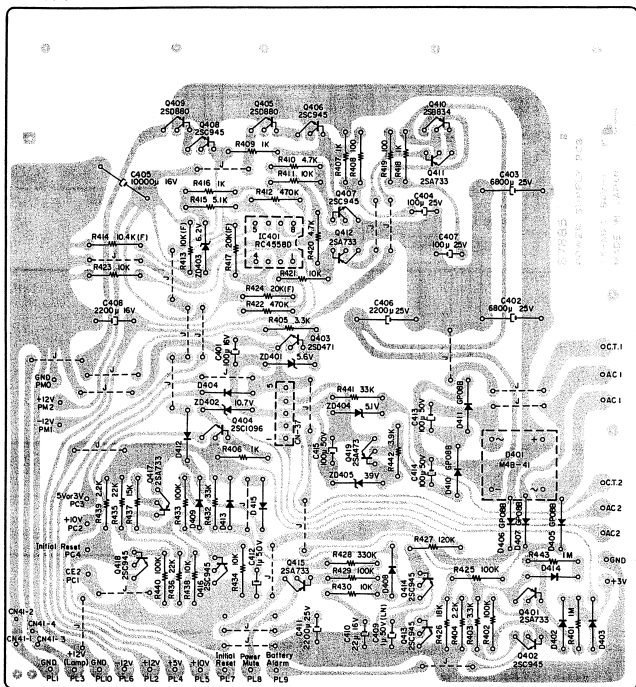

Fig. 7.2 Note: Diode is 1SS53 unless otherwise specified.

Schematic Ref. No.	Part No.	Description	Schematic Ref. No.	Part No.	Description
	BA04234A	Power Supply P.C.B. Ass'y	C412	OB01405A	Electrolytic Capacitor 1μ 50V
			C413,414	OB09313A	Electrolytic Capacitor 100μ 50V
			415		
IC401	OB06124B	IC RC4558D	CN37	OB08724A	5P-T Post
Q401,411	OB06013A	Transistor 2SA733	CN41	OB08743A	4P-H Connector 700mm
412,415					
417					
Q402,406	OB06100A	Transistor 2SC945 (A)			
407,408					
413,414					
416,418					
Q403	OB06066A	Transistor 2SD471			
Q404	OB06020A	Transistor 2SC1096			
Q405,409	OB06255A	Transistor 2SD880 (Y)			
Q410	OB06256A	Transistor 2SB834 (Y)			
Q419	OB06060A	Transistor 2SA473 (Y)			
ZD401	OB06268A	Zener Diode 5.6V RD5.6EB3			
ZD402	OB06231A	Zener Diode 10.7V RD11EB3			
ZD403	OB06167A	Zener Diode 6.2V RD6.2EB3			
ZD404	OB06230A	Zener Diode 5.1V RD5.1EB3			
ZD405	OB06235A	Zener Diode 39V RD39EB3			
D401	OB06267A	Diode Bridge M4B-41			
D402,403	OB06181A	Silicon Diode 1SS53 (9 pcs.)			
404,408					
409					
412-415					
D405,406	OB06109A	Silicon Diode GP08B			
407,410					
411					
R401,443	OB05776A	Carbon Resistor 1M ERD-25T J			
R402,425	OB01889A	Carbon Resistor 100K ERD-25T J			
429,433					
440					
R403,405	OB01681A	Carbon Resistor 3.3K ERD-25T J			
R404,439	OB05622A	Carbon Resistor 2.2K ERD-25T J			
R406,407	OB01857A	Carbon Resistor 1K ERD-25T J			
409,416					
418					
R408,419	OB01679A	Carbon Resistor 100 ERD-25T J			
R410,420	OB01846A	Carbon Resistor 4.7K ERD-25T J			
R411,421	OB01888A	Carbon Resistor 10K ERD-25T J			
423,430					
434,438					
R412,422	OB01684A	Carbon Resistor 470K ERD-25T J			
R413	OB09203A	Metal Film Resistor 10K SN14K2E F			
R414	OB09433A	Metal Film Resistor 10.4K SN14K2E F			
R415	OB09314A	Carbon Resistor 5.1K ERD-25T J			
R417,424	OB09439A	Metal Film Resistor 20K SN14K2E F			
R426	OB05660A	Carbon Resistor 18K ERD-25T J			
R427	OB05621A	Carbon Resistor 120K ERD-25T J			
R428	OB05627A	Carbon Resistor 330K ERD-25T J			
R432,441	OB05609A	Carbon Resistor 33K ERD-25T J			
R435,436	OB05615A	Carbon Resistor 22K ERD-25T J			
R437	OB01683A	Carbon Resistor 15K ERD-25T J			
R442	OB05675A	Carbon Resistor 3.9K ERD-25T J			
C401	OB01400A	Electrolytic Capacitor 100μ 16V			
C402,403	OB09374A	Electrolytic Capacitor 6800μ 25V			
C404,407	OB01272A	Electrolytic Capacitor 100μ 25V			
C405	OB09487A	Electrolytic Capacitor 10000μ 16V			
C406,411	OB05654A	Electrolytic Capacitor 2200μ 25V			
C408	OB01406A	Electrolytic Capacitor 2200μ 16V			
C409	OB09223A	Electrolytic Capacitor 1μ 50V (LLN)			
C410	OB01862A	Electrolytic Capacitor 22μ 16V			

7.3. Pin Jack P.C.B. Ass'y

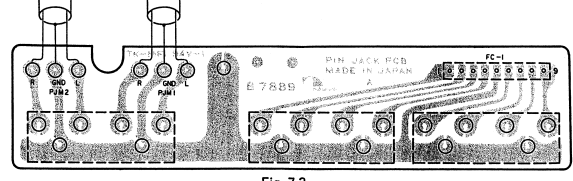

Fig. 7.3

7.4. MIC Jack P.C.B. Ass'y

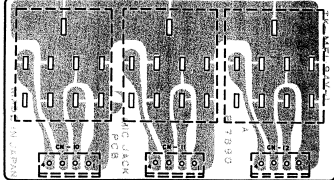

Fig. 7.4

7.5. RAMM Control Switch P.C.B. Ass'y

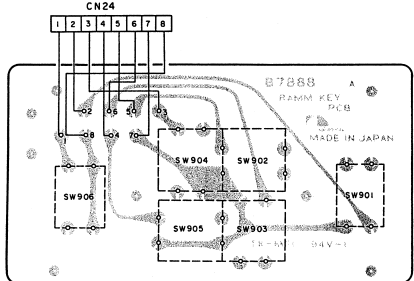

Fig. 7.5

7.6. Function Switch P.C.B. Ass'y

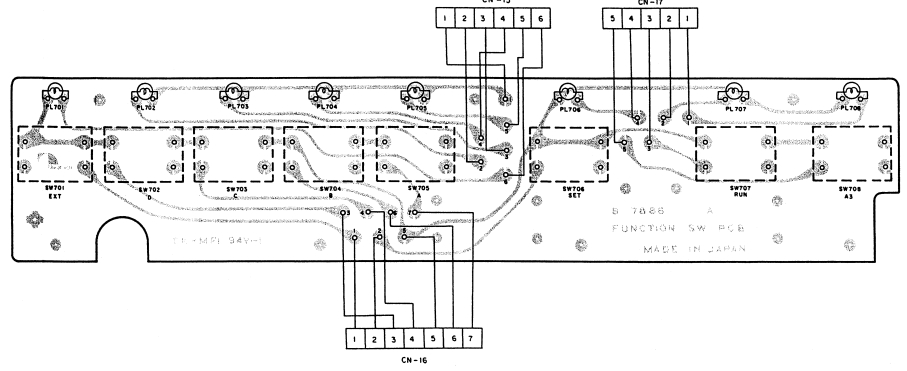

Fig. 7.6

7.7. Mechanism Control Switch P.C.B. Ass'y

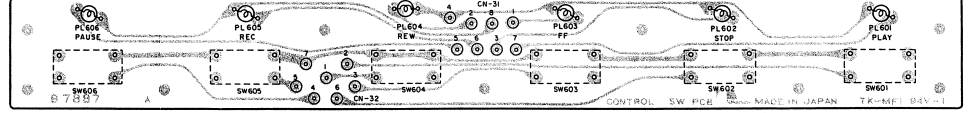

Fig. 7.7

Schematic Ref. No.	Part No.	Description	Schematic Ref. No.	Part No.	Description
FC1	BA04242A	Pin Jack P.C.B. Ass'y	CN15, 11, 12	BA04240A	Function Switch P.C.B. Ass'y
	0B07889A	Pin Jack P.C.B.		0B07886A	Function Switch P.C.B.
	0B05247A	9P Flat Cable 140mm		0B08721A	Lamp 12V 30mA (8 pcs.)
CN10,11,12	0B08726A	Pin Jack Unit UA-1047 (3 pcs.)	0B07254A	Push Switch EVQ-PXR04K (8 pcs.)	
	0B07890A	MIC Jack P.C.B.	0B08750B	6P-H Connector 600mm	
	0B08654A	4P-T Post	0B08751A	7P-H Connector 630mm	
SW901-906, CN24	0B08725A	MIC Jack HLJ0259-01-010 (3 pcs.)	0B08749A	5P-H Connector 600mm	
	BA04241A	RAMM Control Switch P.C.B. Ass'y	BA04239A	Mechanism Control Switch P.C.B. Ass'y	
	0B07888A	RAMM Control Switch P.C.B.	0B07887A	Mechanism Control Switch P.C.B.	
SW901-906, CN24	0B07254A	Push Switch EVQ-PXR04K (6 pcs.)	0B08722A	Lamp 12V 60mA	
	0B08752A	8P-H Connector 380mm	0B07254A	Push Switch EVQ-PXR04K	
			0B08748A	8P-H Connector 200mm	
			0B08747A	7P-H Connector 200mm	

7.8. Speed Cal. P.C.B. Ass'y

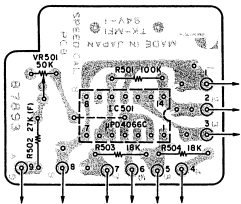

Fig. 7.8

7.9. Counter Pulse Generator P.C.B. Ass'y

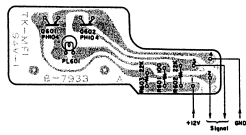

Fig. 7.9

7.10. Shut-off P.C.B. Ass'y

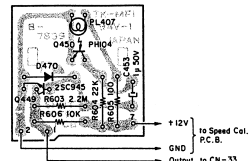

Fig. 7.10

Note: Diode is 1SS53 unless otherwise specified.

Schematic Ref. No.	Part No.	Description	Schematic Ref. No.	Part No.	Description
	BA04238A	Speed Cal. P.C.B. Ass'y	IC615	0B06223A	IC μ PD4040C
IC501	0B07893A	Speed Cal. P.C.B. IC	Q601	0B06013A	Transistor 2SA733
VR501	0B07269A	Semi-fixed Volume 50K	Q602	0B06100A	Transistor 2SC945 (A)
R601	0B01889A	Carbon Resistor 100K ERD-25T J	D601-609	0B06181A	Silicon Diode 1SS53 (9 pcs.)
R502	0B09444A	Metal Film Resistor 27K SN14K2E F	R601,605	0B07270A	Semi-fixed Volume 20K
R503,504	0B05560A	Carbon Resistor 18K ERD-25T J	607,611	0B01889A	Carbon Resistor 10K ERD-25T J
			612,615		
	BA04237B	Counter Pulse Generator P.C.B. Ass'y	616,629		
Q601,602	0B07933A	Counter Pulse Generator P.C.B. IC	630	0B05641A	Carbon Resistor 47K ERD-25T J
R601	0B06228A	Carbon Resistor PH-104	R602,603		
R602,603	0B01679A	Carbon Resistor 100 ERD-25T J	631	0B01889A	Carbon Resistor 100K ERD-25T J
PL601	0B05615A	Carbon Resistor 22K ERD-25T J	R608,609	0B05615A	Carbon Resistor 22K ERD-25T J
	0B08552A	Lamp 12V 25mA	610,621		
	0C06281B	P.C.B. Holder (1 pcs.)	623,624		
	0E00792A	BT Screw M2.6x6 Phillips Pan Head (2 pcs.)	625,626		
			627,628		
	BA04070A	Shut-off P.C.B. Ass'y	R613	0B09463A	Metal Film Resistor 110K SN14K2E F
Q449	0B07839A	Shut-off P.C.B. Transistor	R614	0B09203A	Metal Film Resistor 10K SN14K2E F
Q450	0B06228A	Photo Transistor PH104	R617	0B01857A	Carbon Resistor 1K ERD-25T J
D470	0B06181A	Silicon Diode 1SS53	R618	0B09525A	Metal Film Resistor 70.6K SN14K2E F
R603	0B05671A	Carbon Resistor 2.2M ERD-25T J	R619	0B09524A	Metal Film Resistor 60.4K SN14K2E F
R604	0B05615A	Carbon Resistor 22K ERD-25T J	R620	0B09523A	Metal Film Resistor 13.7K SN14K2E F
R605	0B09215A	Fail Safe Type Resistor 100 R0F-255 J	C601	0B09414A	PP Capacitor 560P 100V G
R606	0B01889A	Carbon Resistor 10K ERD-25T J	C602	0B05657A	Tantalum Capacitor 4.7 μ 16V
C453	0B01405A	Electrolytic Capacitor 1 μ 50V	C603	0B09290A	Ceramic Capacitor 0.01 μ 50V Z
PL407	0B08552A	Lamp 12V 25mA	C604	0B09191A	PP Capacitor 4700P 100V G
	BA04245A	FL Indicator P.C.B. A Ass'y	C605	0B09285A	Ceramic Capacitor 330P 50V K
IC601	0B07895A	FL Indicator P.C.B. A IC	CN21	0B08744A	7P-H Connector Ass'y 200mm
IC602,604	0B06144A	IC μ PD4066C	CN38	0B08734A	6P-T Connector F6P-HVQ
611	0B06219A	IC μ PD4081C	CN39	0B08735A	11P-T Connector F11P-HVQ
IC603,613	0B06178A	IC μ PD4011C	CN40	0B08733A	5P-T Connector F5P-HVQ
IC605	0B06216A	IC μ PC4556C			
IC606,610	0B06143A	IC μ PD4001C			
IC607	0B06217A	IC RC4560D			
IC608	0B06262A	IC μ PD4025C			
IC609	0B06214A	IC μ PD4071C			
IC612,614	0B06244A	IC μ PD4073BC			

7.11. FL Indicator P.C.B. A Ass'y

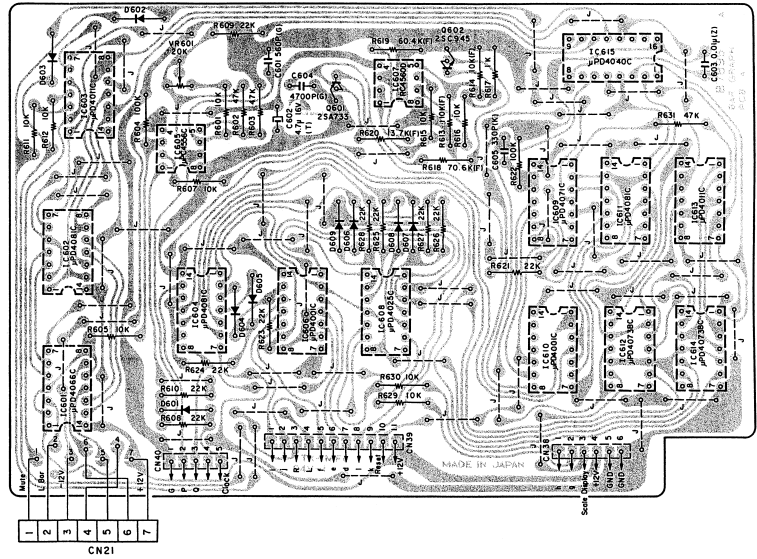

Fig. 7.11

Note: Diode is 1SS53 unless otherwise specified.

7.12. FL Indicator P.C.B. B Ass'y

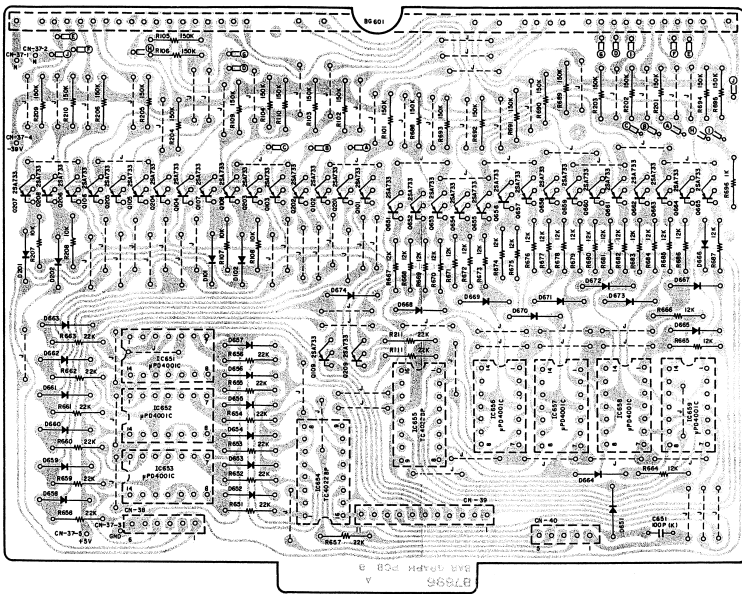

Fig. 7.12 Note: Diode is 1SS53 unless otherwise specified.

Schematic Ref. No.	Part No.	Description
BA04246A		FL Indicator P.C.B. B Ass'y
IC651-653	0B07896A	FL Indicator P.C.B. B
656-659	0B06143A	IC μ PD4001C (7 pcs.)
IC654,655	0B06218A	IC TC4022BP
Q101-109	0B06013A	Transistor 2SA733 (33 pcs.)
201-209		
651-665		
D101,102	0B06181A	Silicon Diode 1SS53 (28 pcs.)
201,202		
651-674		
R101-106	0B05626A	Carbon Resistor 150K ERD-25T J (24 pcs.)
109,110		
201-206		
209,210		
688-695		
R107,108	0B01888A	Carbon Resistor 10K ERD-25T J
207,208		
R111,211	0B05615A	Carbon Resistor 22K ERD-25T J (15 pcs.)
651-663		
R664-687	0B09263A	Carbon Resistor 12K ERD-25T J (24 pcs.)
R696	0B01857A	Carbon Resistor 1K ERD-25T J
C651	0B09282A	Ceramic Capacitor 100P 50V K
BG601	0B08717A	FL Indicator FIP58BW18Y
CN37	0B08745A	5P-H Connector
CN38	0B08182A	6P-T Post
CN39	0B08253A	11P-T Post
CN40	0B08183A	5P-T Post

7.13. Detector P.C.B. Ass'y

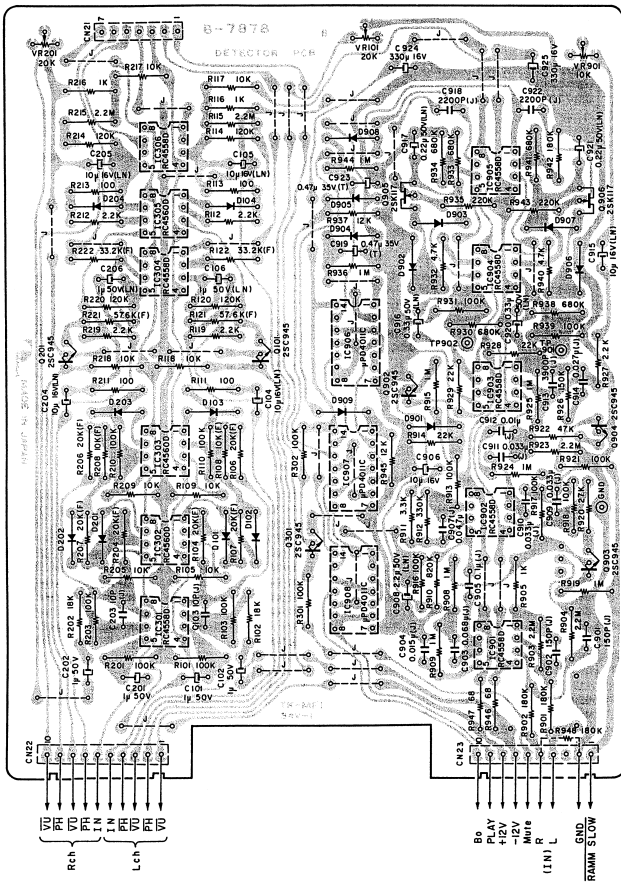

Fig. 7.13 Note: Diode is 1SS53 unless otherwise specified.

Schematic Ref. No.	Part No.	Description	Schematic Ref. No.	Part No.	Description
	BA04230A	Detector P.C.B. Ass'y	R922	0B05641A	Carbon Resistor 47K ERD-25T J
			R926	0B05626A	Carbon Resistor 150K ERD-25T J
			R930,933	0B09335A	Carbon Resistor 680K ERD-25T J
IC301,304	0B07878B	Detector P.C.B.	941		
902,903	0B06124B	IC RC4558D	R832,940	0B01846A	Carbon Resistor 4.7K ERD-25T J
904,905			R835,943	0B05625A	Carbon Resistor 220K ERD-25T J
IC302,303	0B06217A	IC RC4560D	R937,945	0B09263A	Carbon Resistor 12K ERD-25T J
305			R946,947	0B09306A	Fail Safe Type Resistor 68 RFD-25S J
IC906,907	0B06178A	IC μ PD4011C	C101,102	0B01405A	Electrolytic Capacitor 1 μ 50V
908			201,202		
Q101,201	0B06100A	Transistor 2SC945 (A)	C103,203	0B09277A	Ceramic Capacitor 10P 50V J
301,902			C104,105	0B09148A	Electrolytic Capacitor 10 μ 16V (LN)
903,904			204,205		
Q905,906	0B06129A	FET 2SK117 (Y)	915		
D101-104	0B06181A	Silicon Diode 1SS53 (17 pcs.)	C106,206	0B09223A	Electrolytic Capacitor 1 μ 50V (LN)
201-204			C901,902	0B09281A	Ceramic Capacitor 150P 50V J
901-909			C903	0B05682A	Mylar Capacitor 0.068 μ 50V J
VR101,201	0B07215A	Semi-fixed Volume 20K	C904	0B05557A	Mylar Capacitor 0.015 μ 50V J
VR901	0B07162A	Semi-fixed Volume 10K	C905	0B01780A	Mylar Capacitor 0.1 μ 50V J
R101,103	0B01889A	Carbon Resistor 100K ERD-25T J	C906	0B01412A	Electrolytic Capacitor 10 μ 16V
110,201			C907	0B05796A	Mylar Capacitor 0.047 μ 50V J
203,210			C908	0B09332A	Electrolytic Capacitor 2.2 μ 50V (LN)
301,302			C909,910	0B05583A	Mylar Capacitor 0.033 μ 50V J
913,916			911		
917,918			C912	0B05681A	Mylar Capacitor 0.01 μ 50V J
921,931			C913	0B01804A	Mylar Capacitor 3900P 50V J
939			C914	0B09045A	Mylar Capacitor 0.027 μ 50V J
R102,202	0B05560A	Carbon Resistor 18K ERD-25T J	C916,920	0B09337A	Electrolytic Capacitor 0.33 μ 50V (LN)
R104,106	0B09439A	Metal Film Resistor 20K SN14K2E F	C917,921	0B09144A	Electrolytic Capacitor 0.22 μ 50V (LN)
107,204			C918,922	0B01802A	Mylar Capacitor 2200P 50V J
206,207			C919,923	0B05792A	Tantalum Capacitor 0.47 μ 35V
R105,109	0B01888A	Carbon Resistor 10K ERD-25T J	C924,925	0B01502A	Electrolytic Capacitor 330 μ 16V
117,118			CN21	0B08643A	7P-T Post
205,209			CN22,23	0B08731A	10P-S Connector F10P-SHVQ
217,218					
R108,208	0B09203A	Metal Film Resistor 10K SN14K2E F			
R111,113	0B01679A	Carbon Resistor 100 ERD-25T J			
211,213					
R112,119	0B05622A	Carbon Resistor 2.2K ERD-25T J			
212,219					
927					
R114,120	0B05621A	Carbon Resistor 120K ERD-25T J			
214,220					
R115,215	0B05671A	Carbon Resistor 2.2M ERD-25T J			
903,904					
923					
R116,216	0B01857A	Carbon Resistor 1K ERD-25T J			
905					
R121,221	0B09454A	Metal Film Resistor 57.6K SN14K2E F			
R122,222	0B09446A	Metal Film Resistor 33.2K SN14K2E F			
R901,902	0B05640A	Carbon Resistor 180K ERD-25T J			
942,948					
R908,909	0B05776A	Carbon Resistor 1M ERD-25T J			
915,919					
924,925					
936,944					
R910	0B09320A	Carbon Resistor 820K ERD-25T J			
R911	0B01681A	Carbon Resistor 3.3K ERD-25T J			
R912	0B05627A	Carbon Resistor 330K ERD-25T J			
R914,928	0B05615A	Carbon Resistor 22K ERD-25T J			
929					
R920	0B05743A	Carbon Resistor 27K ERD-25T J			

1000ZXL

7.14. Record Dolby NR P.C.B. Ass'y

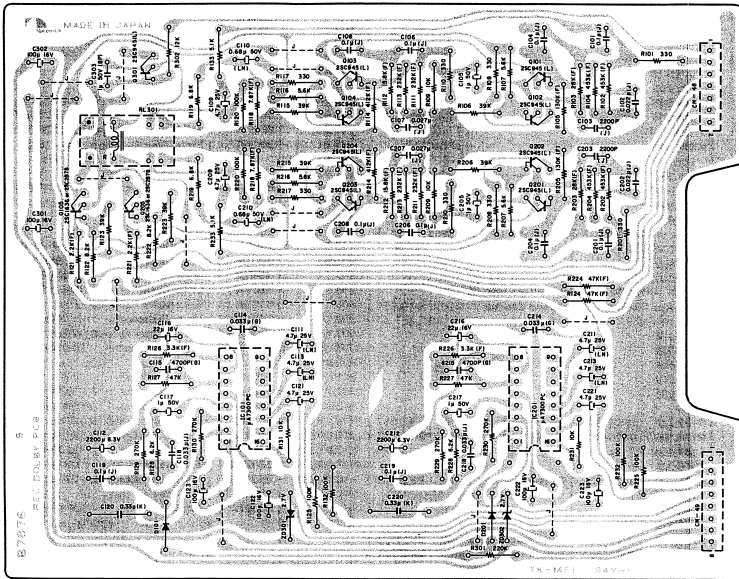

Fig. 7.14 Note: Diode is 1SS53 unless otherwise specified.

Schematic Ref. No.	Part No.	Description	Schematic Ref. No.	Part No.	Description
	BA04236A	Record Dolby NR P.C.B. Ass'y	C111,113	OB09333A	Electrolytic Capacitor 4.7 μ 25V (LN)
IC101,201	OB07876B	Record Dolby NR P.C.B.	211,213	OB09257A	Electrolytic Capacitor 2200 μ 6.3V
Q101,102	OB06200A	IC μ A7300PC	C112,212	OB09240A	PP Capacitor 0.033 μ 50V G
103,104	OB01872A	Transistor 2SC945 (L)	C114,214	OB09191A	PP Capacitor 4700P 50V G
201,202			C115,215	OB01892A	Electrolytic Capacitor 22 μ 16V
203,204			C118,218	OB05583A	Mylar Capacitor 0.033 μ 50V J
301			C120,220	OB09399A	Mylar Capacitor 0.33 μ 100V K
Q105,205	OB06070A	Transistor 2SC1636	C122,123	OB01400A	Electrolytic Capacitor 100 μ 16V
	(OB06299A)	(2SC2878)	222,223		
ZD301,302	OB06191A	Zener Diode 2.7V 2.7EB	301,302		
D101,201	OB01909A	Silicon Diode 1S1555	C303	OB09187A	Electrolytic Capacitor 1 μ 50V (BP)
R101,108	OB05577A	Carbon Resistor 330 ERD-25T J	RL301	OB07326A	FBR Relay 12V
110,117			CN48	OB08729A	7P-S Connector F7P-SHVQ
201,208			CN49	OB08730A	8P-S Connector F8P-SHVQ
210,217				OB08714A	IC Socket 16P (2 pcs.)
R102,104	OB09480A	Metal Film Resistor 453K SN14K2E F		BA04231A	Record Eq. Amp. P.C.B. Ass'y
R103,203	OB09445A	Metal Film Resistor 28K SN14K2E F		OB07877A	Record Eq. Amp. P.C.B.
R105,205	OB09466A	Metal Film Resistor 130K SN14K2E F		OB06144A	IC μ PD4066C
R106,115	OB01854A	Carbon Resistor 39K ERD-25T J	IC101,102	OB06216A	IC μ PD4508BC
123,206			201,202		
215,223			304,305		
R107,116	OB01887A	Carbon Resistor 5.6K ERD-25T J	IC303,203	OB06146A	IC RC4558DD
207,216			306,307	OB06128A	IC RC4558DD MC
R109,131	OB01888A	Carbon Resistor 10K ERD-25T J	IC303	OB06147A	IC Transistor
209,231			Q101,102	OB01872A	Transistor 2SC945 (L)
R111,113	OB09473A	Metal Film Resistor 232K SN14K2E F	103,104		
211,213			201,202		
R112,212	OB09437A	Metal Film Resistor 15.8K SN14K2E F	203,204		
R114,214	OB09478A	Metal Film Resistor 412K SN14K2E F	Q105,205	OB06013A	Transistor 2SA733
R118,218	OB09430A	Metal Film Resistor 7.87K SN14K2E F	L101,201	OB00068A	Trap Coil 10.5mH
R119,219	OB01682A	Carbon Resistor 6.8K ERD-25T J	R101,121	OB05560A	Carbon Resistor 18K ERD-25T J
R120,125	OB01889A	Carbon Resistor 100K ERD-25T J	201,221		
132,220			R102,202	OB05621A	Carbon Resistor 120K ERD-25T J
225,232			R103,203	OB09442A	Metal Film Resistor 22.3K SN14K2E F
R121,221	OB09420A	Metal Film Resistor 2.2K SN14K2E F	R104,204	OB09229A	Metal Film Resistor 18K SN14K2E F
R122,222	OB01856A	Carbon Resistor 8.2K ERD-25T J	R105,205	OB09464A	Metal Film Resistor 121K SN14K2E F
R124,224	OB09451A	Metal Film Resistor 47K SN14K2E F	R106,206	OB09454A	Metal Film Resistor 57.6K SN14K2E F
R126,226	OB09317A	Metal Film Resistor 3.3K SN14K2E F	R107,207	OB09443A	Metal Film Resistor 26.4K SN14K2E F
R127,227	OB05641A	Carbon Resistor 47K ERD-25T J	R108,111	OB05508A	Carbon Resistor 56K ERD-25T J
R128,228	OB09271A	Carbon Resistor 6.2K ERD-25T J	114,142		
R129,130	OB05620A	Carbon Resistor 270K ERD-25T J	208,211		
229,230			214,242		
R133,233	OB09314A	Carbon Resistor 5.1K ERD-25T J	R109,112	OB05626A	Carbon Resistor 150K ERD-25T J
R301	OB05625A	Carbon Resistor 220K ERD-25T J	115,119		
R302	OB09263A	Carbon Resistor 12K ERD-25T J	143,209		
C101,104	OB01780A	Mylar Capacitor 0.1 μ 50V J	212,215		
106,108			219,243		
119,201			R110,113	OB01854A	Carbon Resistor 39K ERD-25T J
204,206			116,144		
208,219			145,210		
C102,202	OB05582A	Mylar Capacitor 0.022 μ 50V J	213,216		
C103,203	OB01802A	Mylar Capacitor 2200P 50V J	244,245		
C105,117	OB01405A	Electrolytic Capacitor 1 μ 50V	R117,217	OB09428A	Metal Film Resistor 5.76K SN14K2E F
205,217			R118,218	OB05577A	Carbon Resistor 330 ERD-25T J
C107,207	OB09045A	Mylar Capacitor 0.027 μ 50V J	R120,220	OB05743A	Carbon Resistor 27K ERD-25T J
C109,121	OB01402A	Electrolytic Capacitor 4.7 μ 25V	R122,131	OB09203A	Metal Film Resistor 10K SN14K2E F
209,221			222,231		
C110,210	OB09395A	Electrolytic Capacitor 0.68 μ 50V (LN)	R123,223	OB05620A	Carbon Resistor 270K ERD-25T J

Schematic Ref. No.	Part No.	Description
R124,224	0B09466A	Metal Film Resistor 130K SN14K2E F
R125,225	0B09298A	Metal Film Resistor 64.9K SN14K2E F
R126,226	0B09446A	Metal Film Resistor 33.2K SN14K2E F
R127,227	0B09438A	Metal Film Resistor 16.5K SN14K2E F
R128,228	0B09431A	Metal Film Resistor 8.06K SN14K2E F
R129,229	0B09423A	Metal Film Resistor 4.02K SN14K2E F
R130,230	0B09419A	Metal Film Resistor 2K SN14K2E F
R132,232	0B09436A	Metal Film Resistor 14K SN14K2E F
R133,233	0B09335A	Carbon Resistor 680K ERD-25T J
R134,234	0B09380A	Carbon Resistor 1.5M ERD-25T J
R135,235	0B05962A	Carbon Resistor 1.2M ERD-25T J
R136,236	0B09357A	Metal Film Resistor 33K SN14K2E F
R137,237	0B09391A	Carbon Resistor 91K ERD-25T J
R138,238	0B05675A	Carbon Resistor 3.9K ERD-25T J
R139,239	0B05974A	Carbon Resistor 680 ERD-25T J
R140,240	0B05641A	Carbon Resistor 47K ERD-25T J
R141,241	0B05622A	Carbon Resistor 2.2K ERD-25T J
R146,246	0B05627A	Carbon Resistor 330K ERD-25T J
R147-154	0B05625A	Carbon Resistor 220K ERD-25T J (24 pcs.)
303-310		
R301,302	0B09049A	Fail Safe Type Resistor 22 ERD-14F J
C101,201	0B09045A	Mylar Capacitor 0.027μ 50V J
C102,202	0B09223A	Electrolytic Capacitor 1μ 50V (LN)
C103,119	0B09403A	PP Capacitor 620P 100V J
203,219		
C104,204	0B05687A	Mylar Capacitor 1200P 50V J
C105,205	0B01802A	Mylar Capacitor 2200P 50V J
C106,206	0B05636A	Tantalum Capacitor 22μ 16V
C107,207	0B09247A	Mica Capacitor 220P 50V J
C108,110	0B09488A	Ceramic Capacitor 30P 50V J
208,210		
C109,209	0B09484A	PP Capacitor 470P 100V G
C111,211	0B09408A	PP Capacitor 1000P 100V G
C112,212	0B09485A	PP Capacitor 680P 100V G
C113,213	0B09486A	Mica Capacitor 120P 50V J
C114,214	0B09397A	Electrolytic Capacitor 470μ 10V (LN)
C115,215	0B09412A	PP Capacitor 0.011μ 100V G
C116,216	0B09094A	Tantalum Capacitor 1μ 50V
C117,217	0B09375A	Electrolytic Capacitor 47μ 10V (LN)
C118,218	0B05909A	Mylar Capacitor 0.12μ 50V J
C120,220	0B09189A	Mylar Capacitor 2700P 50V J
C121,221	0B01913A	Mylar Capacitor 1800P 50V J
C301,302	0B01502A	Electrolytic Capacitor 330μ 16V
CN45,46	0B06127A	5P-S Connector F5P-SHVQ
CN51	0B08644A	8P-T Post
CN52	0B08654A	4P-T Post

7.15. Record Eq. Amp. P.C.B. Ass'y

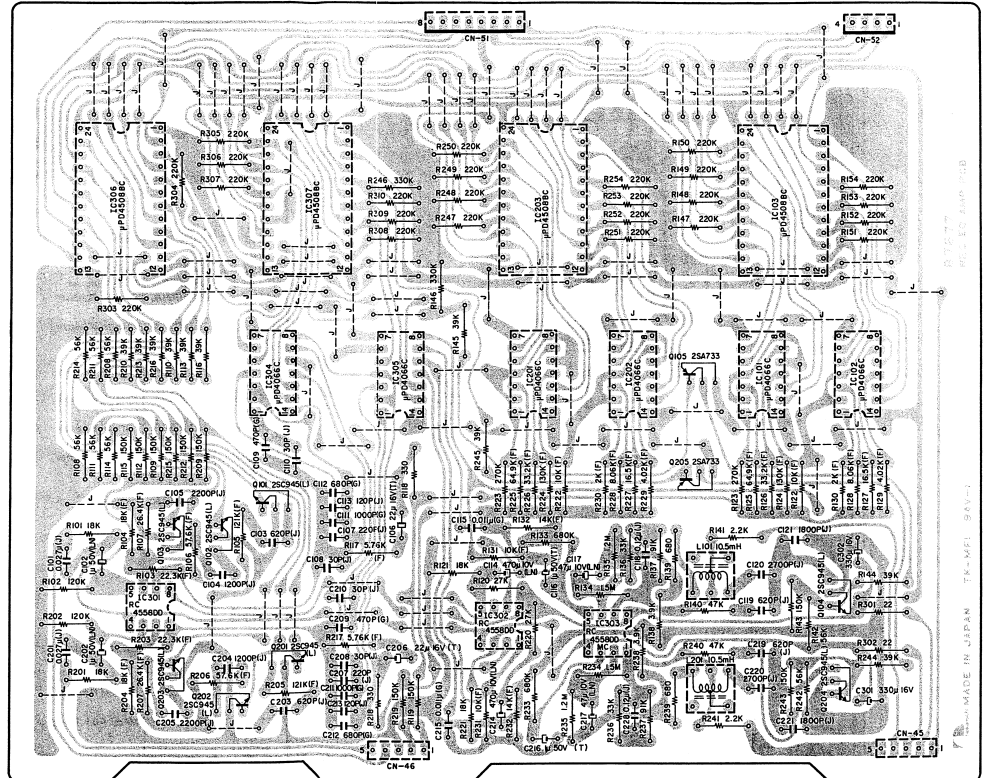
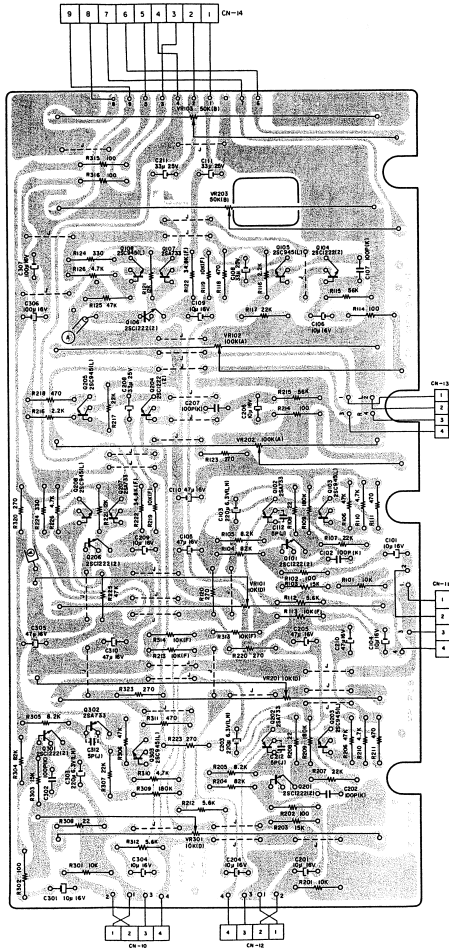

Fig. 7.15

Note: Diode is 1SS53 unless otherwise specified.

7.16. MIC Amp. and Volume P.C.B. Ass'y



Note: Diode is 1S553 unless otherwise specified.

Fig. 7.16

Schematic Ref. No.	Part No.	Description	Schematic Ref. No.	Part No.	Description
	BA04232A	MIC Amp. and Volume P.C.B. Ass'y	C102,107 202,207 302	OB09282A	Ceramic Capacitor 100P 50V K
Q101,104 106,201 204,206 301	OB07884B OB06062A	MIC Amp. and Volume P.C.B. Transistor 2SC1222 (2)	C103,203 303	OB09151A	Electrolytic Capacitor 220μ 6.3V (LN)
Q102,107 202,207 302	OB06013A	Transistor 2SA733	C105,110 205,210 305,310	OB01403A	Electrolytic Capacitor 47μ 16V
Q103,105 106,203 205,208 303	OB01872A	Transistor 2SC945 (L)	C108,111 208,211 C112,212 312	OB09251A	Electrolytic Capacitor 33μ 25V
VR101,201 301	OB07331A	Slide Volume 10K (D)	OB09276A	Ceramic Capacitor 5P 50V J	
VR102,202	OB07332A	Slide Volume 100K (A)	OB01400A	Electrolytic Capacitor 100μ 16V	
VR103,203	OB07333A	Slide Volume 50K (B)	OB08754A	4P-H Connector 520mm	
R101,201	OB01888A	Carbon Resistor 10K ERD-25T J	OB08779A	4P-H Connector	
R102,202 114,214 302	OB01679A	Carbon Resistor 100 ERD-25T J	OB08780A	4P-H Connector	
R103,203 303	OB01683A	Carbon Resistor 15K ERD-25T J	OB08755A	4P-H Connector 320mm	
R104,204 304	OB05668A	Carbon Resistor 82K ERD-25T J	OB08753A	9P-H Connector 320mm	
R105,205 305	OB01856A	Carbon Resistor 8.2K ERD-25T J			
R106,206 125,225 306	OB05641A	Carbon Resistor 47K ERD-25T J	BA04235A	Playback Amp. and Dolby NR P.C.B. 2nd Version	
R107,207 117,217 307	OB05615A	Carbon Resistor 22K ERD-25T J	OB07875C	Playback Amp. and Dolby NR P.C.B. IC	
R108,208 308	OB05579A	Carbon Resistor 22 ERD-25T J	OB06200A	IC μA7300PC	
R109,209 309	OB05640A	Carbon Resistor 180K ERD-25T J	OB06205A	IC RC4559DD	
R110,210 126,226 310	OB01846A	Carbon Resistor 4.7K ERD-25T J	OB06257A	FET 2SK240 (BL)	
R111,211 118,218 311	OB05576A	Carbon Resistor 470 ERD-25T J	(OB06300A)	(OB06300A)	
R112,212 312	OB01887A	Carbon Resistor 5.6K ERD-25T J	OB01872A	Transistor 2SC945 (L)	
R113,119 213,219 313,314	OB09203A	Metal Film Resistor 10K SN14K2E F	ZD301,302	OB06191A	Zener Diode 2.7V 2.7E
R115,215 R116,216	OB05508A OB05622A	Carbon Resistor 56K ERD-25T J Carbon Resistor 2.2K ERD-25T J	ZD303,304	OB06233A	Zener Diode 10V RD10EB3
R120,123 220,223 320,323	OB05645A	Carbon Resistor 270 ERD-25T J	D101,201	OB01909A	Silicon Diode 1S1555
R121,221 R122,222	OB09263A OB09447A	Carbon Resistor 12K ERD-25T J Metal Film Resistor 34.8K SN14K2E F	L101,201	OB06636A	Inductor 1.05mH
R124,224	OB05577A	Carbon Resistor 330 ERD-25T J	L102,202	OB00008A	Trap Coil 10.5mH
R315,316	OB09215A	Fail Safe Type Resistor 100 RDF-25S J	L103,203	OB03919B	Inductor 36mH
C101,104 106,109 201,204 206,209 301,304	OB01412A	Electrolytic Capacitor 10μ 16V	VR101,201	OB07353A	Semi-fixed Volume 200
			VR102,202	OB07162A	Semi-fixed Volume 10K
			R101,124 201,224	OB05615A	Carbon Resistor 22K ERD-25T J
			R102,202 R103,107 203,207	OB09540A	Metal Film Resistor 3.24K SN14K2E F
			OB01846A	OB01846A	Carbon Resistor 4.7K ERD-25T J
			R104,204 R105,205 R106,122 206,222	OB01933A	Carbon Resistor 220 ERD-25T J
			R108,132	OB09415A	Metal Film Resistor 68 SN14K2E F
			R109,209	OB09422A	Metal Film Resistor 3.16K SN14K2E F
			R110,210 R111,112 212,213	OB01889A	Carbon Resistor 100K ERD-25T J
			R114,116 R115,128	OB09521A	Metal Film Resistor 523K SN14K2E F
			R130,215 228,230	OB09205A	Metal Film Resistor 18K SN14K2E F
			R117,217 R118,218 R119,219	OB01857A	Carbon Resistor 1K ERD-25T J
				OB09520A	Carbon Resistor 620K ERD-25T J
				OB05620A	Carbon Resistor 270K ERD-25T J
				OB05676A	Carbon Resistor 390K ERD-25T J
				OB01854A	Carbon Resistor 39K ERD-25T J
				OB01887A	Carbon Resistor 5.6K ERD-25T J

Schematic Ref. No.	Part No.	Description
R120,220	OB05577A	Carbon Resistor 330 ERD-25T J
R121,221	OB09421A	Metal Film Resistor 2.67K SN14K2E F
R123,127 223,227	OB05641A	Carbon Resistor 47K ERD-25T J
R125,131 225,231	OB01888A	Carbon Resistor 10K ERD-25T J
R126,226	OB09317A	Metal Film Resistor 3.3K SN14K2E F
R129,229	OB09271A	Carbon Resistor 6.2K ERD-25T J
R133,233	OB05671A	Carbon Resistor 2.2M ERD-25T J
R134,234	OB01679A	Carbon Resistor 100 ERD-25T J
R301	OB05625A	Carbon Resistor 220K ERD-25T J
R303,304	OB09306A	Fail Safe Type Resistor 68 RDF-25S J
C101,201	OB09486A	Mica Capacitor 120P 50V J
C102,202	OB05681A	Mylar Capacitor 0.01μ 50V J
C103,203	OB09152A	Electrolytic Capacitor 470μ 6.3V (LN)
C104,204	OB09489A	PP Capacitor 5600P 100V G
C105,205	OB05550A	Mylar Capacitor 1000P 50V J
C106,206	OB09345A	Electrolytic Capacitor 3.3μ 25V (BP)
C107,108 128,129 207,208 228,229 303,304 305,306	OB01400A	Electrolytic Capacitor 100μ 16V
C109,209	OB09410A	PP Capacitor 2200P 100V J
C110,113 210,213	OB09189A	Mylar Capacitor 2700P 50V J
C111,211	OB09275A	Mica Capacitor 200P 50V J
C112,212	OB09235A	PP Capacitor 680P 100V J
C114,116 214,216	OB05813A	Mylar Capacitor 0.056μ 50V J
C115,126 215,226	OB01780A	Mylar Capacitor 0.1μ 50V J
C117,217	OB09413A	PP Capacitor 0.022μ 100V G
C118,122 218,222	OB09333A	Electrolytic Capacitor 4.7μ 25V (LN)
C119,219	OB09257A	Electrolytic Capacitor 2200μ 6.3V
C120,220	OB09240A	PP Capacitor 0.033μ 100V G
C121,221	OB09191A	PP Capacitor 4700P 100V G
C123,223	OB01862A	Electrolytic Capacitor 22μ 16V
C124,224	OB01405A	Electrolytic Capacitor 1μ 50V
C125,225	OB05583A	Mylar Capacitor 0.033μ 50V J
C127,227	OB09399A	Mylar Capacitor 0.33μ 100V K
C130,230	OB09400A	Mica Capacitor 250P 50V J
C131,231	OB09270A	PP Capacitor 470P 50V J
C301,302	OB01412A	Electrolytic Capacitor 10μ 16V
CN46	OB08727A	5P-S Connector F5P-SHVQ
CN47	OB08728A	6P-S Connector F6P-SHVQ
CN53	OB08654A	4P-T Post
	OB08714A	IC Socket 16P (2 pcs.)

7.17. Playback Amp. and Dolby NR P.C.B. Ass'y

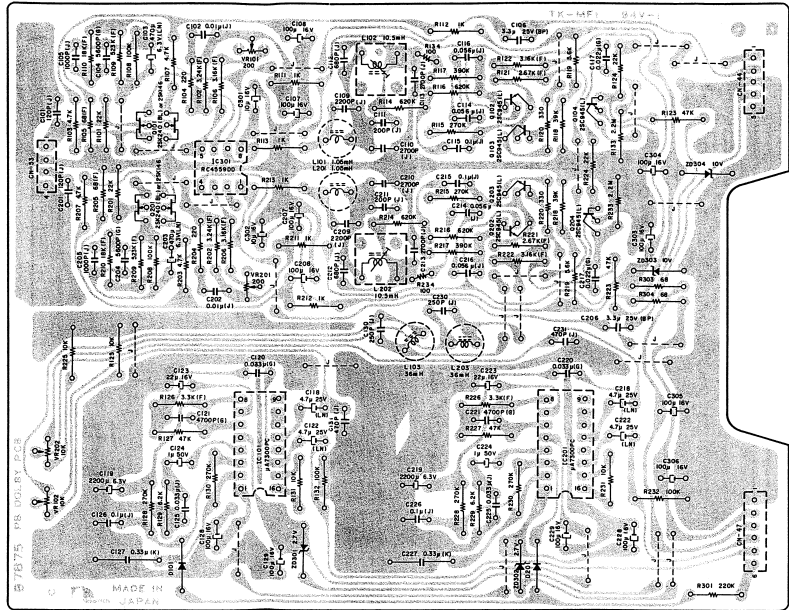

Fig. 7.17.1 2nd Version

Note: Diode is 1SS53 unless otherwise specified.

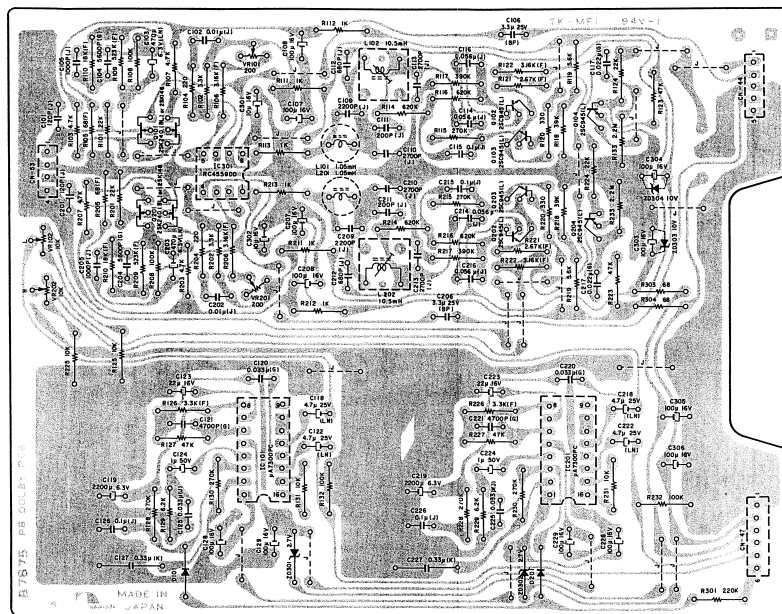

Fig. 17.12 1st Version

Note: Diode is 1S553 unless otherwise specified.

Schematic Ref. No.	Part No.	Description
	BA04235A	Playback Amp. and Dolby NR P.C.B. Ass'y 1st Version
	0B07875A	Playback Amp. and Dolby NR P.C.B.
IC101, 201	0B06200A	IC μ A7300PC
IC301	0B06205A	IC RC4559DD
Q101, 201	0B06257A	FET 2SK240 (RL) (2SK146 (V))
Q102, 103	0B01872A	Transistor 2SC945 (L)
104, 202		
203, 204		
ZD301, 302	0B06191A	Zener Diode 2.7V 2.7E
ZD303, 304	0B06233A	Zener Diode 10V RD10EB3
D101, 201	0B01909A	Silicon Diode 1S1555
L101, 201	0B06636A	Inductor 1.05mH
L102, 202	0B00089A	Trap Coil 10.5mH
VR101, 201	0B07353A	Semi-fixed Volume 20K
VR102, 202	0B07162A	Semi-fixed Volume 10K
R101, 124	0B05615A	Carbon Resistor 22K ERD-25T J
201, 224		
R102, 202	0B01681A	Carbon Resistor 3.3K ERD-25T J
R103, 107	0B01846A	Carbon Resistor 4.7K ERD-25T J
203, 207		
R104, 204	0B01933A	Carbon Resistor 220 ERD-25T J
R105, 205	0B09415A	Metal Film Resistor 68 SN14K2E F
R106, 122	0B09422A	Metal Film Resistor 3.16K SN14K2E F
206, 222		
R108, 132	0B01889A	Carbon Resistor 100K ERD-25T J
208, 232		
R109, 209	0B09521A	Metal Film Resistor 523K SN14K2E F
R110, 210	0B09205A	Metal Film Resistor 18K SN14K2E F
R111, 112	0B01857A	Carbon Resistor 1K ERD-25T J
113, 211		
212, 213		
R114, 116	0B09520A	Carbon Resistor 620K ERD-25T J
214, 216		
R115, 128	0B05620A	Carbon Resistor 270K ERD-25T J
130, 215		
228, 230		
R117, 217	0B05676A	Carbon Resistor 390K ERD-25T J
R118, 218	0B01854A	Carbon Resistor 39K ERD-25T J
R119, 219	0B01887A	Carbon Resistor 5.6K ERD-25T J
R120, 220	0B05577A	Carbon Resistor 330 ERD-25T J
R121, 221	0B09421A	Metal Film Resistor 2.67K SN14K2E F
R123, 127	0B05641A	Carbon Resistor 47K ERD-25T J
223, 227		
R125, 131	0B01888A	Carbon Resistor 10K ERD-25T J
225, 231		
R126, 226	0B09317A	Metal Film Resistor 3.3K SN14K2E F
R129, 229	0B09271A	Carbon Resistor 6.2K ERD-25T J
R133, 233	0B05671A	Carbon Resistor 2.2M ERD-25T J
R301	0B05625A	Carbon Resistor 5.6K ERD-25T J
R303, 304	0B09306A	Fail Safe Type Resistor 68
C101, 201	0B09486A	Mica Capacitor 120P 50V J
C102, 202	0B05681A	Mylar Capacitor 0.01 μ 50V J
C103, 203	0B09152A	Electrolytic Capacitor 470 μ 6.3V (LN)
C104, 204	0B09489A	PP Capacitor 5600P 100V G
C105, 205	0B05550A	Mylar Capacitor 1000P 50V J
C106, 206	0B09345A	Electrolytic Capacitor 3.3 μ 25V (BP)

Schematic Ref. No.	Part No.	Description
C107,108 128,129 207,208 228,229 303,304 305,306	0B01400A	Electrolytic Capacitor 100 μ 16V
C109,209	0B09410A	PP Capacitor 2200P 100V J
C110,113 210,213	0B09189A	Mylar Capacitor 2700P 50V J
C111,211	0B09275A	Mica Capacitor 200P 50V J
C112,212	0B09235A	PP Capacitor 680P 100V J
C114,116 214,216	0B05813A	Mylar Capacitor 0.056 μ 50V J
C115,126 215,226	0B01780A	Mylar Capacitor 0.1 μ 50V J
C117,217	0B09413A	PP Capacitor 0.022 μ 100V G
C118,122 218,222	0B09333A	Electrolytic Capacitor 4.7 μ 25V (LN)
C119,219	0B09257A	Electrolytic Capacitor 2200 μ 6.3V
C120,220	0B09240A	PP Capacitor 0.033 μ 100V G
C121,221	0B09191A	PP Capacitor 4700P 100V G
C123,223	0B01862A	Electrolytic Capacitor 22 μ 16V
C124,224	0B01405A	Electrolytic Capacitor 1 μ 50V
C125,225	0B0583A	Mylar Capacitor 0.033 μ 50V J
C127,227	0B09399A	Mylar Capacitor 0.33 μ 100V K
C301,302	0B01412A	Electrolytic Capacitor 10 μ 16V
CN46	0B08727A	5P-S Connector F5P-SHVQ
CN47	0B08728A	6P-S Connector F6P-SHVQ
CN53	0B08654A	4P-T Post
	0B08714A	IC Socket 16P (2 pcs.)

7.18. Main P.C.B. Ass'y

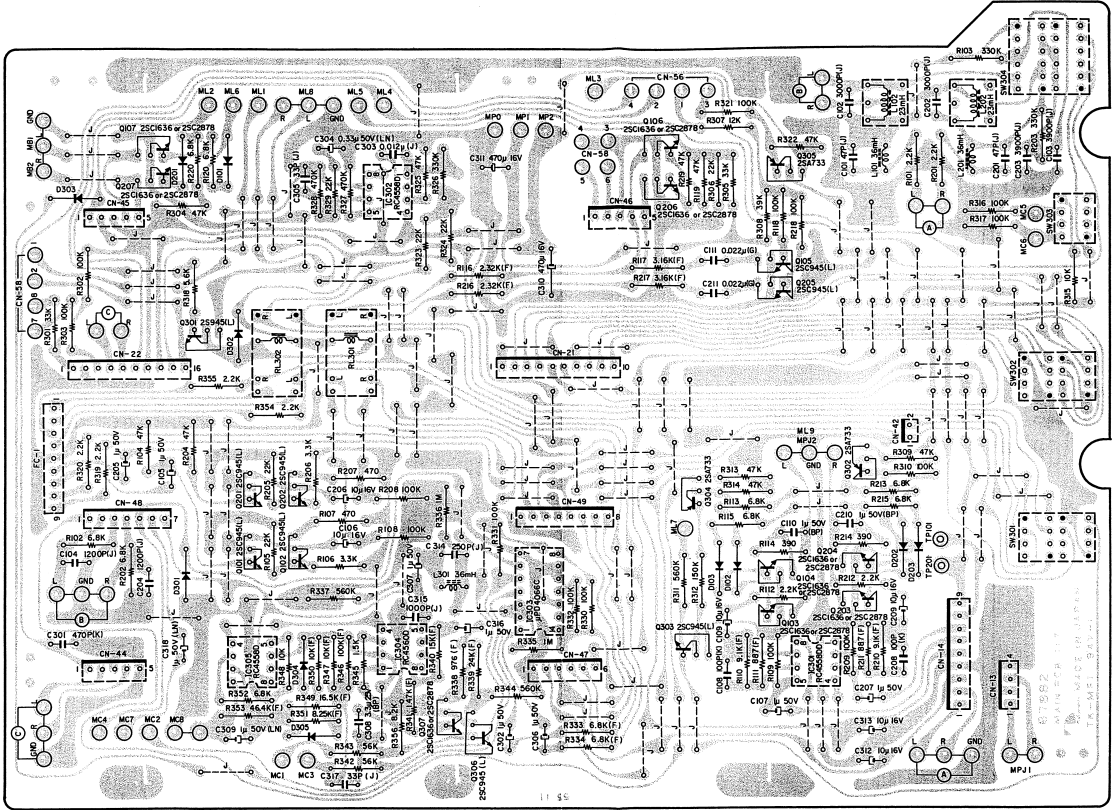

Fig. 7.18.1 2nd Version

Note: Diode is 1SS53 unless otherwise specified.

Schematic Ref. No.	Part No.	Description	Schematic Ref. No.	Part No.	Description
	BA04227A	Main P.C.B. Ass'y 2nd Version	R311,337 344	OB05784A	Carbon Resistor 560K ERD-25T J
	OB07882C	Main P.C.B.	R312	OB05626A	Carbon Resistor 150K ERD-25T J
IC301	OB06146A	IC RC4558DD	R315,348	OB01888A	Carbon Resistor 10K ERD-25T J
IC302,305	OB06124B	IC RC4558D	R318	OB01887A	Carbon Resistor 5.6K ERD-25T J
IC303	OB06144A	IC μPD4066C	R327,328	OB01684A	Carbon Resistor 470K ERD-25T J
IC304	OB06217A	IC RC4560D	R333,334	OB09529A	Metal Film Resistor 6.8K SN14K2E F
Q101,102	OB01872A	Transistor 2SC945 (L)	R335,336	OB05776A	Carbon Resistor 1M ERD-25T J
105,201			R338	OB09416A	Metal Film Resistor 976 SN14K2E F
202,205			R339	OB09005A	Metal Film Resistor 24K SN14K2E F
301,303			R340	OB09340A	Metal Film Resistor 15K SN14K2E F
306			R341	OB09551A	Metal Film Resistor 1.47K SN14K2E F
Q103,104	OB06070A	Transistor 2SC1636	R342,343	OB05508A	Carbon Resistor 56K ERD-25T J
106,107	(OB06299A)	(2SC2878)	R345	OB05698A	Carbon Resistor 1.5K ERD-25T J
203,204			R346	OB09305A	Metal Film Resistor 100K SN14K2E F
206,207			R347,350	OB09203A	Metal Film Resistor 10K SN14K2E F
307			R349	OB09438A	Metal Film Resistor 16.5K SN14K2E F
Q302,304	OB06013A	Transistor 2SA733	R351	OB09432A	Metal Film Resistor 8.25K SN14K2E F
305			R353	OB09450A	Metal Film Resistor 46.4K SN14K2E F
D101-103	OB06181A	Silicon Diode 1SS53 (11 pcs.)	R356	OB01856A	Carbon Resistor 8.2K ERD-25T J
201-203			C101,201	OB09242A	Mica Capacitor 47P 50V J
301-305			C102,202	OB09262A	PP Capacitor 3000P 50V J
L101,201	OB03919B	Inductor 36mH	C103,203	OB01804A	Mylar Capacitor 3900P 50V J
301			C104,204	OB05687A	Mylar Capacitor 1200P 50V J
L102,202	OB03563A	19K Coil 23mH	C105,107	OB01405A	Electrolytic Capacitor 1μ 50V
R101,112	OB05622A	Carbon Resistor 2.2K ERD-25T J	205,207		
201,212			302,306		
319,320			307,316		
354,355			C106,109	OB01412A	Electrolytic Capacitor 10μ 16V
R102,113	OB01682A	Carbon Resistor 6.8K ERD-25T J	206,209		
115,120			312,313		
202,213			C108,208	OB09282A	Ceramic Capacitor 100P 50V K
215,220			C110,210	OB09187A	Electrolytic Capacitor 1μ 50V (BP)
352			C111,211	OB09413A	PP Capacitor 0.022μ 100V G
R103,203	OB05627A	Carbon Resistor 330K ERD-25T J	C301	OB09286A	Ceramic Capacitor 470P 50V K
326			C303	OB05843A	Mylar Capacitor 0.012μ 50V J
R104,119	OB05641A	Carbon Resistor 47K ERD-25T J	C304	OB09385A	Electrolytic Capacitor 0.33μ 50V (LN)
204,219			C305,317	OB09370A	Ceramic Capacitor 33P 50V J
304,309			C308	OB09345A	Electrolytic Capacitor 3.3μ 25V (BP)
313,314			C309,318	OB09223A	Electrolytic Capacitor 1μ 50V (LN)
322,325			C310,311	OB01392A	Electrolytic Capacitor 470μ 16V
R105,205	OB05615A	Carbon Resistor 22K ERD-25T J	C314	OB09400A	Mica Capacitor 250P 50V J
306,323			C315	OB05550A	Mylar Capacitor 1000P 50V J
324,329			RL301,302	OB07326A	FBR Relay 12V
R106,206	OB01681A	Carbon Resistor 3.3K ERD-25T J	SW301	OB07324A	Rotary Switch 4-2N
R107,207	OB05576A	Carbon Resistor 470 ERD-25T J	SW302	OB07322A	Rotary Switch 4-2S
R108,109	OB01889A	Carbon Resistor 100K ERD-25T J	SW303	OB07323A	Rotary Switch 2-3N
118,208			SW304	OB07321A	Rotary Switch 4-4S
209,218			CN13	OB08654A	4P-T Post
302,303			CN14	OB08645A	9P-T Post
310,316			CN21,22	OB08615A	10P-T Post B10P-SHF-1
317,321			CN42	OB08656A	2P-T Post
330,331			CN44,45	OB08183A	5P-T Post B5P-SHF-1
332			46		
R110,210	OB09328A	Metal Film Resistor 9.1K SN14K2E F	CN47	OB08182A	6P-T Post B6P-SHF-1
R111,211	OB09550A	Metal Film Resistor 887 SN14K2E F	CN48	OB08302A	7P-T Post B7P-SHF-1
R114,214	OB05691A	Carbon Resistor 390 ERD-25T J	CN49	OB08334A	8P-T Post B8P-SHF-1
R116,216	OB09468A	Metal Film Resistor 2.32K SN14K2E F	CN56	OB08736A	4P-H Connector 600mm
R117,217	OB09422A	Metal Film Resistor 3.16K SN14K2E F	CN58	OB08737A	8P-H Connector 500mm
R301,305	OB05509A	Carbon Resistor 33K ERD-25T J			
R307	OB09263A	Carbon Resistor 12K ERD-25T J			
R308	OB01854A	Carbon Resistor 39K ERD-25T J			

Schematic Ref. No.	Part No.	Description	Schematic Ref. No.	Part No.	Description
	BA04227A	Main P.C.B. Ass'y 1st Version	R311,337 344	OB05784A	Carbon Resistor 560K ERD-25T J
	OB07882A	Main P.C.B.	R312	OB05626A	Carbon Resistor 150K ERD-25T J
IC301	OB06146A	IC RC4558DD	R315,348	OB01888A	Carbon Resistor 10K ERD-25T J
IC302,305	OB06124B	IC RC4558D	R318	OB01887A	Carbon Resistor 5.6K ERD-25T J
IC303	OB06144A	IC μ PD4066C	R327,328	OB01684A	Carbon Resistor 470K ERD-25T J
IC304	OB06217A	IC RC4560D	R333,334	OB09529A	Metal Film Resistor 6.8K SN14K2E F
Q101,102	OB01872A	Transistor 2SC945 (L)	R335,336	OB05776A	Carbon Resistor 1M ERD-25T J
105,201			R338	OB09416A	Metal Film Resistor 976 SN14K2E F
202,205			R339	OB09005A	Metal Film Resistor 24K SN14K2E F
301,303			R340	OB09340A	Metal Film Resistor 15K SN14K2E F
306			R341	OB09492A	Metal Film Resistor 1.62K SN14K2E F
Q103,104	OB06070A (OB06299A)	Transistor 2SC1636 (2SC2878)	R342,343 357	OB05508A	Carbon Resistor 56K ERD-25T J
106,107			R345	OB05698A	Carbon Resistor 1.5K ERD-25T J
203,204			R346	OB09305A	Metal Film Resistor 100K SN14K2E F
206,207			OB09203A	OB09203A	Metal Film Resistor 10K SN14K2E F
307			R349	OB09438A	Metal Film Resistor 16.5K SN14K2E F
Q302,304	OB06013A	Transistor 2SA733	R351	OB09432A	Metal Film Resistor 8.25K SN14K2E F
305			R353	OB09450A	Metal Film Resistor 46.4K SN14K2E F
D101-103	OB06181A	Silicon Diode 1SS53 (11 pcs.)	R356	OB01856A	Carbon Resistor 8.2K ERD-25T J
201-203			C101,201	OB09242A	Mica Capacitor 47P 50V J
301-305			C102,202	OB09262A	PP Capacitor 3000P 50V J
L101,201	OB03919B	Inductor 36mH	C103,203	OB01804A	Mylar Capacitor 3900P 50V J
301			C104,204	OB05687A	Mylar Capacitor 1200P 50V J
L102,202	OB03563A	19K Coil 23mH	C105,107	OB01405A	Electrolytic Capacitor 1 μ 50V
R101,112	OB05622A	Carbon Resistor 2.2K ERD-25T J	205,207		
201,212			302,306		
319,320			307,316		
354,355			C106,109	OB01412A	Electrolytic Capacitor 10 μ 16V
R102,113	OB01682A	Carbon Resistor 6.8K ERD-25T J	206,209		
115,120			312,313		
202,213			C108,208	OB09282A	Ceramic Capacitor 100P 50V K
215,220			C110,210	OB09187A	Electrolytic Capacitor 1 μ 50V (BP)
352			C111,211	OB09413A	PP Capacitor 0.022 μ 100V G
R103,203	OB05627A	Carbon Resistor 330K ERD-25T J	C301	OB09286A	Ceramic Capacitor 470P 50V K
326			C303	OB05843A	Mylar Capacitor 0.012 μ 50V J
R104,119	OB05641A	Carbon Resistor 47K ERD-25T J	C304	OB09385A	Electrolytic Capacitor 0.33 μ 50V (LN)
204,219			C305,317	OB09370A	Ceramic Capacitor 33P 50V J
304,309			C308	OB09345A	Electrolytic Capacitor 3.3 μ 25V (BP)
313,314			C309,318	OB09223A	Electrolytic Capacitor 1 μ 50V (LN)
322,325			C310,311	OB01392A	Electrolytic Capacitor 470 μ 16V
R105,205	OB05615A	Carbon Resistor 22K ERD-25T J	C314	OB09400A	Mica Capacitor 250P 50V J
306,323			C315	OB05550A	Mylar Capacitor 1000P 50V J
324,329			C319	OB09219A	Electrolytic Capacitor 6.8 μ 16V (LN)
R106,206	OB01681A	Carbon Resistor 3.3K ERD-25T J	RL301,302	OB07326A	FBR Relay 12V
R107,207	OB05576A	Carbon Resistor 470 ERD-25T J	SW301	OB07324A	Rotary Switch 4-2N
R108,109	OB01889A	Carbon Resistor 100K ERD-25T J	SW302	OB07322A	Rotary Switch 4-2S
118,208			SW303	OB07323A	Rotary Switch 2-3N
209,218			SW304	OB07321A	Rotary Switch 4-4S
302,303			CN13	OB08654A	4P-T Post
310,316			CN14	OB08645A	9P-T Post
317,321			CN21,22	OB08615A	10P-T Post B10P-SHF-1
330,331			CN42	OB08656A	2P-T Post
332			CN44,45	OB08183A	5P-T Post B5P-SHF-1
R110,210	OB09328A	Metal Film Resistor 9.1K SN14K2E F	46		
R111,211	OB09491A	Metal Film Resistor 1K SN14K2E F	CN47	OB08182A	6P-T Post B6P-SHF-1
R114,214	OB05691A	Carbon Resistor 390 ERD-25T J	CN48	OB08302A	7P-T Post B7P-SHF-1
R116,216	OB09468A	Metal Film Resistor 2.32K SN14K2E F	CN49	OB08334A	8P-T Post B8P-SHF-1
R117,217	OB09422A	Metal Film Resistor 3.16K SN14K2E F	CN56	OB08736A	4P-H Connector 600mm
R301,305	OB05509A	Carbon Resistor 33K ERD-25T J	CN58	OB08737A	8P-H Connector 500mm
R307	OB09263A	Carbon Resistor 12K ERD-25T J			
R308	OB01854A	Carbon Resistor 39K ERD-25T J			

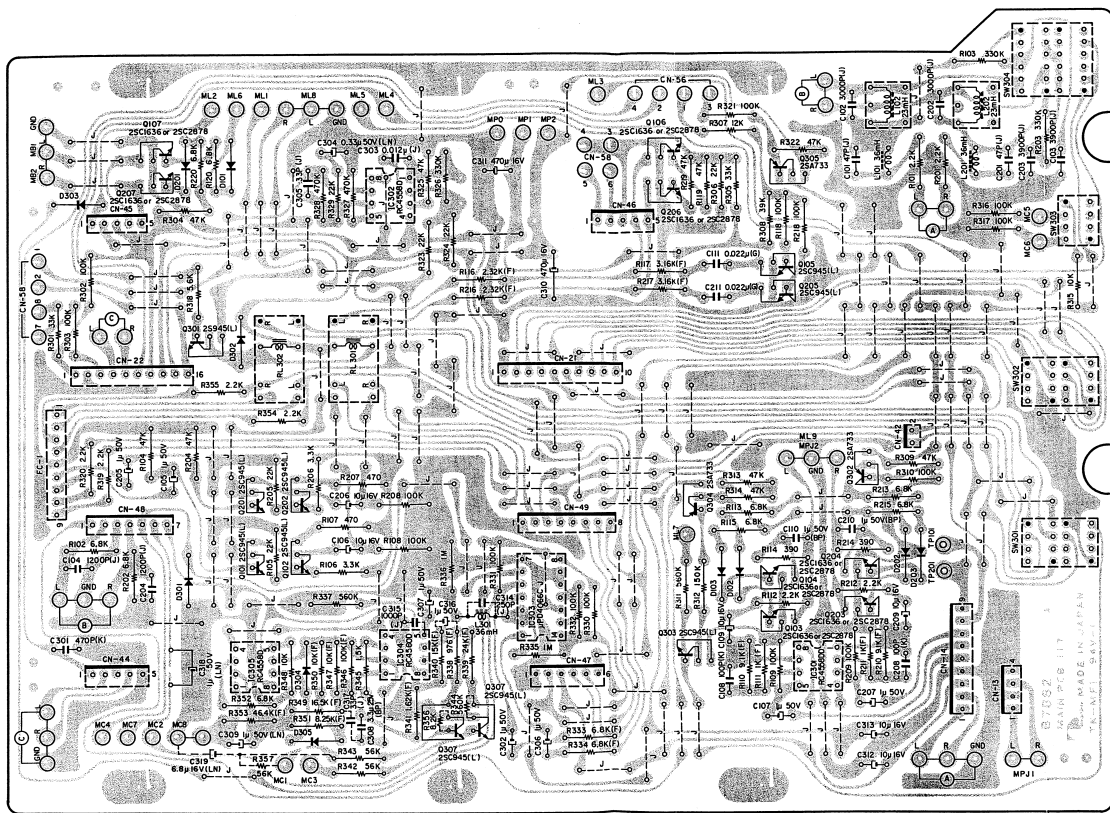

Fig. 7.18.2 1st Version

Note: Diode is 1SS53 unless otherwise specified.

1000ZXL

7.19. Logic P.C.B. Ass'y

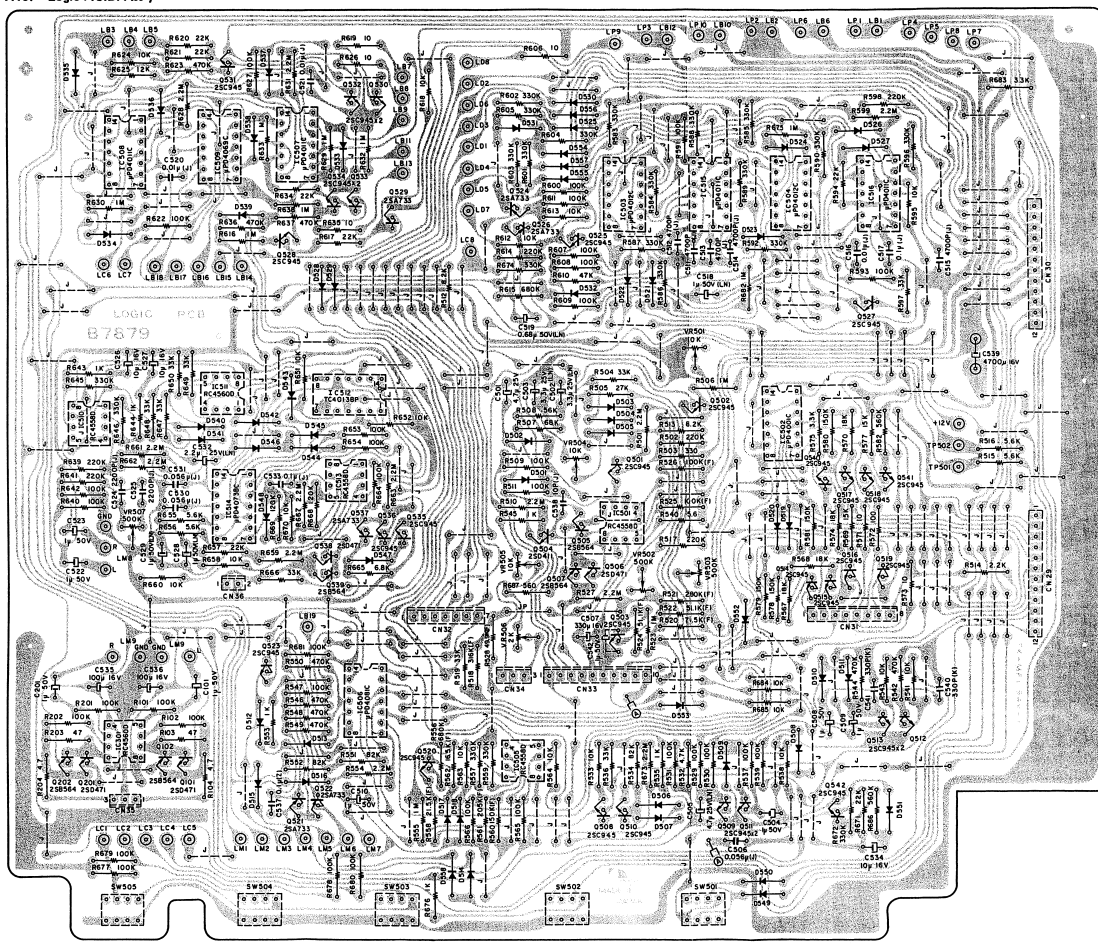

Fig. 7.19

Note: Diode is 1SS53 unless otherwise specified.

Schematic Ref. No.	Part No.	Description
	BA04244B	Logic P.C.B. Ass'y
IC301,511	080789C	Logic P.C.B.
IC501,505	0806217A	IC RC4560D
510,513	0806124B	IC RC4568D
IC502	0806143A	IC μ PD4001C
IC503,504	0806263A	IC μ PD4012C
IC506	0806219A	IC μ PD4081C
IC507,508	0806178A	IC μ PD4011C
515,516		
IC509	0806270A	IC μ PD4069C
IC512	0806213A	IC TC4013BP
IC514	0806244A	IC μ PD4073BC
Q101,201	0806066A	Transistor 2SD471
504,506		
538		
Q102,202	0806069A	Transistor 2SB564
505,507		
539		
Q501-503	0806100A	Transistor 2SC945 (A) (30 pcs.)
508-520		
523,525		
527,528		
530-536		
540-542		
Q521,522	0806013A	Transistor 2SA733
524,526		
529,537		
D501-556	0801909A	Silicon Diode 1S1555 (58 pcs.)
VR501,504	0807256A	Semi-fixed Volume 10K
505		
VR502,503	0807330A	Semi-fixed Volume 500K
507		
VR506	0807329A	Semi-fixed Volume 2K
R101,102	0801889A	Carbon Resistor 100K ERD-25T J
201,202		
509,511		
529,530		
531,537		
539,547		
565,566		
591,593		
600,607		
608,609		
611,622		
627,640		
642,653		
654,664		
677,678		
679,680		
681		
R103,203	0801706A	Carbon Resistor 47 ERD-25T J
R104,204	0809321A	Fail Safe Type Resistor 4.7 RDF-26S J
R501,510	0805671A	Carbon Resistor 2.2M ERD-25T J
527,554		
599,628		
631,659		
661,662		
663,667		
673		

Schematic Ref. No.	Part No.	Description	Schematic Ref. No.	Part No.	Description
R502,517 598,614 639,641	OB05625A	Carbon Resistor 220K ERD-25T J	R569,577 R571,573 606,619 626,635	OB01683A OB09216A	Carbon Resistor 15K ERD-25T J Fail Safe Type Resistor 10 RDF-25S J
R503	OB05577A	Carbon Resistor 330 ERD-25T J	R572	OB09215A	Fail Safe Type Resistor 100 RDF-25S J
R504,519 536,597 647,648 649,650 666	OB05509A	Carbon Resistor 33K ERD-25T J	R575,576 683	OB01681A	Carbon Resistor 3.3K ERD-25T J
R505	OB05743A	Carbon Resistor 27K ERD-25T J	R578,579 580,581	OB05626A	Carbon Resistor 150K ERD-25T J
R506,523 555,616 629,630 632,633 638,675 682	OB05776A	Carbon Resistor 1M ERD-25T J	R582,686 R594,617 620,621 634,657 671	OB05784A OB05615A	Carbon Resistor 560K ERD-25T J Carbon Resistor 22K ERD-25T J
R507	OB05692A	Carbon Resistor 68K ERD-25T J	R610	OB05641A	Carbon Resistor 47K ERD-25T J
R508	OB05508A	Carbon Resistor 56K ERD-25T J	R625	OB09263A	Carbon Resistor 12K ERD-25T J
R512,513	OB01856A	Carbon Resistor 8.2K ERD-25T J	R665	OB01682A	Carbon Resistor 6.8K ERD-25T J
R514	OB05622A	Carbon Resistor 2.2K ERD-25T J	R668,669	OB05621A	Carbon Resistor 120K ERD-25T J
R515,516 655,656	OB01887A	Carbon Resistor 5.6K ERD-25T J	R687	OB05575A	Carbon Resistor 560 ERD-25T J
R518	OB09475A	Metal Film Resistor 316K SN14K2E F	C101,201 504,508 509,510 522,523 542	OB01405A	Electrolytic Capacitor 1μ 50V
R520	OB09457A	Metal Film Resistor 71.5K SN14K2E F	C501	OB01402A	Electrolytic Capacitor 4.7μ 25V
R521	OB09474A	Metal Film Resistor 280K SN14K2E F	C502,503	OB09147A	Electrolytic Capacitor 3.3μ 25V (LN)
R522,524	OB09453A	Metal Film Resistor 51.1K SN14K2E F	C505	OB09333A	Electrolytic Capacitor 4.7μ 25V (LN)
R525,526	OB09305A	Metal Film Resistor 100K SN14K2E F	C506,530 531	OB05813A	Mylar Capacitor 0.056μ 50V J
R528	OB09452A	Metal Film Resistor 49.9K SN14K2E F	C507	OB01502A	Electrolytic Capacitor 330μ 16V
R532	OB01846A	Carbon Resistor 4.7K ERD-25T J	C511,512 513,514 515	OB05652A	Mylar Capacitor 4700P 50V J
R533,538 541,543 563,564 595,612 613,618 624,651 652,658 660,670 684,685	OB01888A	Carbon Resistor 10K ERD-25T J	C516,520 521	OB05681A	Mylar Capacitor 0.01μ 50V J
R534,551 552	OB05668A	Carbon Resistor 82K ERD-25T J	C517,533 C518,528 529	OB01780A OB09223A	Mylar Capacitor 0.1μ 50V J Electrolytic Capacitor 1μ 50V (LN)
R535,545 553,643 644,676	OB01857A	Carbon Resistor 1K ERD-25T J	C519	OB09395A	Electrolytic Capacitor 0.68μ 50V (LN)
R540	OB09217A	Fail Safe Type Resistor 5.6 RDF-25S J	C524,525	OB01802A	Mylar Capacitor 2200P 50V J
R542,544 546,548 549,550 623,636 637	OB01684A	Carbon Resistor 470K ERD-25T J	C526,527 534	OB01412A	Electrolytic Capacitor 10μ 16V
R556,615	OB09335A	Carbon Resistor 680K ERD-25T J	C532	OB09332A	Electrolytic Capacitor 2.2μ 25V (LN)
R557,559 583-590 592,596 601-605 645,646 672,674	OB05627A	Carbon Resistor 330K ERD-25T J (21 pcs.)	C535,536	OB01400A	Electrolytic Capacitor 100μ 16V
R558	OB09440A	Metal Film Resistor 21.5K SN14K2E F	C537	OB09292A	Ceramic Capacitor 0.1μ 50V Z
R560	OB09300A	Metal Film Resistor 150K SN14K2E F	C538	OB09277A	Ceramic Capacitor 10P 50V J
R561	OB09471A	Metal Film Resistor 205K SN14K2E F	C539	OB09377A	Electrolytic Capacitor 4700μ 16V
R562	OB09438A	Metal Film Resistor 16.5K SN14K2E F	C540,541	OB09285A	Ceramic Capacitor 330P 50V K
R567,568 570,574	OB05560A	Carbon Resistor 18K ERD-25T J	SW501,502 504	OB07323A	Rotary Switch 2-3N
			SW503,505	OB07325A	Rotary Switch 2-2N
			CN29,30	OB08178A	12P-T Post
			CN31	OB08644A	8P-T Post
			CN32	OB08643A	7P-T Post
			CN33	OB08645A	9P-T Post
			CN34,35	OB08653A	3P-T Post
			CN36	OB08656A	2P-T Post

Schematic Ref. No.	Part No.	Description	Schematic Ref. No.	Part No.	Description
	BA04228A	CPU P.C.B. A Ass'y	R334,712	OB09356A	Metal Film Resistor 4.7K SN14K2E F
	OB07880B	CPU P.C.B. A	R335	OB09230A	Metal Film Resistor 1.5K SN14K2E F
IC301	OB06216A	IC μ PD4556C	R338,717	OB01889A	Carbon Resistor 100K ERD-25T J
IC302,706	OB06219A	IC μ PD4081C	718,719		
707,708			768,785		
709,710			786,787		
IC303	OB06178A	IC μ PD4011C	788,793		
IC304,713	OB06217A	IC RC4560D	794,795		
IC305	OB06124B	IC RC4558D	796,802		
IC701	OB06253A	IC A.B.L.E. CPU μ PD546C-113	803,806		
IC702	OB06265A	IC μ PD5101LC	807		
IC703	OB06261A	IC μ PD4508BC	R701	OB09522A	Metal Film Resistor 9.53K SN14K2E F
IC704,705	OB06260A	IC μ PD4516BC	R702	OB09439A	Metal Film Resistor 20K SN14K2E F
IC711	OB06214A	IC μ PD4071C	R703	OB01679A	Carbon Resistor 100 ERD-25T J
IC712	OB06143A	IC μ PD4001C	R704	OB09448A	Metal Film Resistor 40.2K SN14K2E F
Q301,302	OB06100A	Transistor 2SC945 (A)	R705	OB09459A	Metal Film Resistor 80.6K SN14K2E F
701,702			R706	OB09467A	Metal Film Resistor 162K SN14K2E F
703,704			R707	OB05627A	Carbon Resistor 330K ERD-25T J
705			R708	OB09335A	Carbon Resistor 680K ERD-25T J
Q303	OB06013A	Transistor 2SA733	R709	OB05963A	Carbon Resistor 1.3M ERD-25T J
Q304	OB06070A	Transistor 2SC1636	R710	OB09380A	Carbon Resistor 1.5M ERD-25T J
	(OB06299A)	(2SC2878)	R713	OB09429A	Metal Film Resistor 7.32K SN14K2E F
D701-716	OB06181A	Silicon Diode 1SS53 (29 pcs.)	R714,715	OB09340A	Metal Film Resistor 15K SN14K2E F
718-730			R716	OB09263A	Carbon Resistor 12K ERD-25T J
L301	OB03919B	Inductor 36mH	R720,721	OB05776A	Carbon Resistor 1M ERD-25T J
VR301,304	OB07329A	Semi-fixed Volume 2K	722		
701,702			R723,724	OB05621A	Carbon Resistor 120K ERD-25T J
VR302,303	OB07270A	Semi-fixed Volume 20K	725,726		
R301,302	OB09305A	Metal Film Resistor 100K SN14K2E F	727,728		
303,304			R729,801	OB05560A	Carbon Resistor 18K ERD-25T J
305			R730-735	OB05675A	Carbon Resistor 3.9K ERD-25T J
R306	OB09472A	Metal Film Resistor 220K SN14K2E F	740-747		
R307	OB09461A	Metal Film Resistor 90.9K SN14K2E F	752-767		
R308	OB09455A	Metal Film Resistor 59K SN14K2E F	R769,770	OB01856A	Carbon Resistor 8.2K ERD-25T J
R309,310	OB05508A	Carbon Resistor 56K ERD-25T J	771,772		
736,737			781,782		
738,739			783,784		
R311	OB09469A	Metal Film Resistor 178K SN14K2E F	R773,774	OB01887A	Carbon Resistor 5.6K ERD-25T J
R312	OB09458A	Metal Film Resistor 73.2K SN14K2E F	775,776		
R313	OB09452A	Metal Film Resistor 49.9K SN14K2E F	R777,778	OB05509A	Carbon Resistor 33K ERD-25T J
R314	OB09534A	Metal Film Resistor 12.7K SN14K2E F	779,780		
R315	OB09460A	Metal Film Resistor 88.7K SN14K2E F	R804	OB01854A	Carbon Resistor 39K ERD-25T J
R316,318	OB09462A	Metal Film Resistor 95.3K SN14K2E F	R805	OB05622A	Carbon Resistor 2.2K ERD-25T J
319			R808	OB05962A	Carbon Resistor 1.2M ERD-25T J
R317	OB09427A	Metal Film Resistor 5.62K SN14K2E F	R809	OB05671A	Carbon Resistor 2.2M ERD-25T J
R320	OB01857A	Carbon Resistor 1K ERD-25T J	C301	OB09411A	PP Capacitor 3300P 50V G
R321,711	OB01888A	Carbon Resistor 10K ERD-25T J	C302	OB09408A	PP Capacitor 1000P 50V G
748,749			C303	OB05950A	PP Capacitor 0.015 μ 50V G
750,751			C304	OB09409A	PP Capacitor 1800P 50V G
R322,328	OB09447A	Metal Film Resistor 34.8K SN14K2E F	C305,318	OB05653A	Mylar Capacitor 1500P 50V J
R323,329	OB09424A	Metal Film Resistor 4.75K SN14K2E F	320		
R324	OB09434A	Metal Film Resistor 11.5K SN14K2E F	C306	OB09246A	Mica Capacitor 150P 50V J
R325	OB09437A	Metal Film Resistor 15.8K SN14K2E F	C307	OB05813A	Mylar Capacitor 0.056 μ 50V J
R326,332	OB09203A	Metal Film Resistor 10K SN14K2E F	C308,310	OB05557A	Mylar Capacitor 0.015 μ 50V J
336			312,313		
R327	OB05641A	Carbon Resistor 47K ERD-25T J	316		
R330	OB09417A	Metal Film Resistor 1.05K SN14K2E F	C309,311	OB05550A	Mylar Capacitor 1000P 50V J
R331	OB09426A	Metal Film Resistor 5.36K SN14K2E F	314,317		
R333,337	OB05615A	Carbon Resistor 22K ERD-25T J	C315	OB05652A	Mylar Capacitor 4700P 50V J
789,790			C319	OB09275A	Mica Capacitor 200P 50V J
791,792			C321	OB09364A	Tantalum Capacitor 0.22 μ 35V
797,798			C701	OB01400A	Electrolytic Capacitor 100 μ 16V
799,800			C702,703	OB01397A	Electrolytic Capacitor 1000 μ 16V

Schematic Ref. No.	Part No.	Description
C704	0B09290A	Ceramic Capacitor 0.01 μ 50V Z
C710	0B05681A	Mylar Capacitor 0.01 μ 50V J
C711	0B05935A	Electrolytic Capacitor 0.68 μ F 50V (LN)
C712	0B01405A	Electrolytic Capacitor 1 μ 50V
CN1,3	0B08760A	10P-H Connector 100mm
CN2	0B08761A	11P-H Connector 100mm
CN4	0B08183A	5P-T Post
CN5	0B08302A	7P-T Post B7P-SHF-1
CN6	0B08334A	8P-T Post B8P-SHF-1
CN7	0B08506A	13P-T Post
CN8	0B08182A	6P-T Post
CN9	0B08615A	10P-T Post
CN57	0B08746A	6P-H Connector 930mm

7.20. CPU P.C.B. A Ass'y

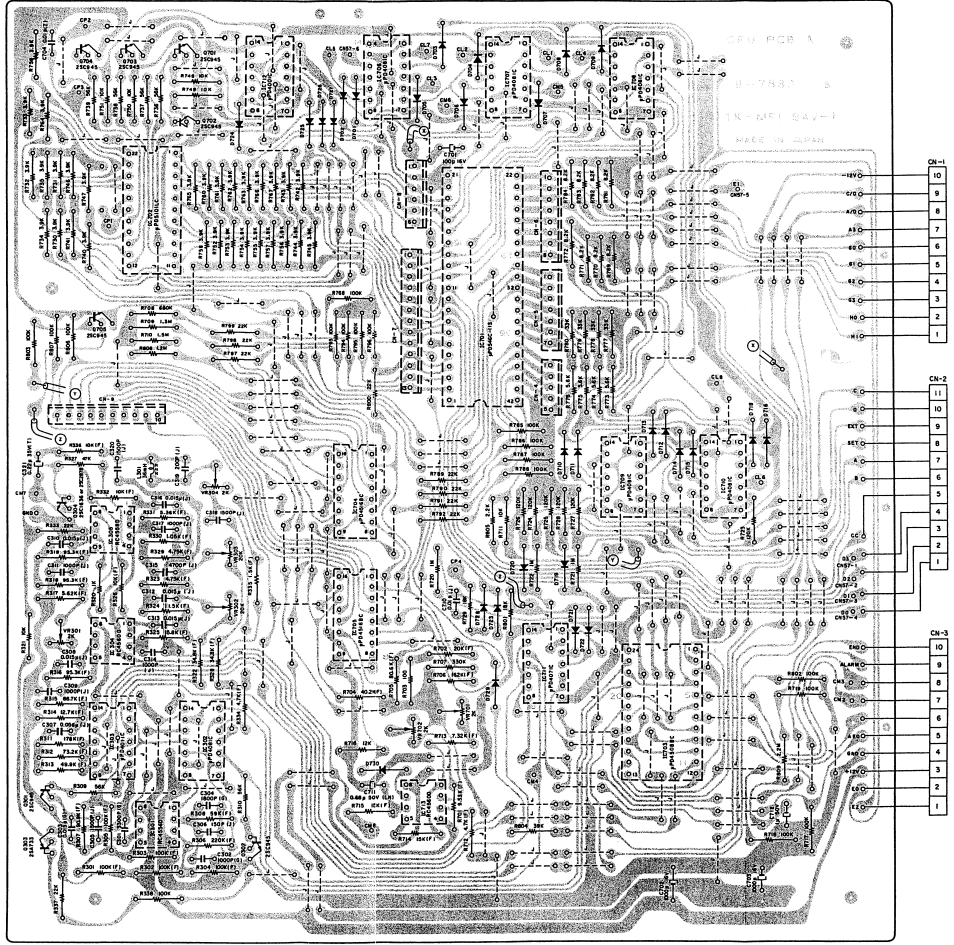

Fig. 7.20

Note: Diode is 1SS53 unless otherwise specified.

7.21. CPU P.C.B. B Ass'y

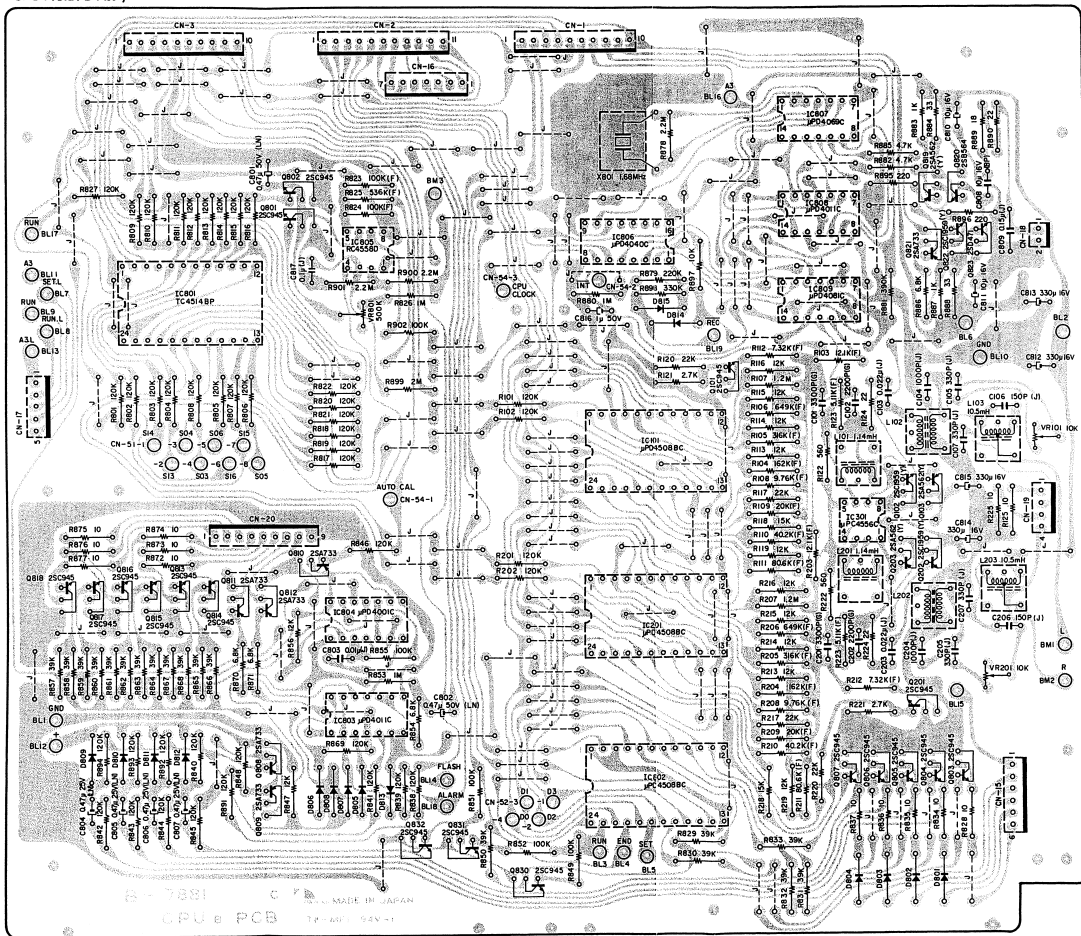

Fig. 7.21.1 3rd Version

Note: Diode is 1SS53 unless otherwise specified.

Schematic Ref. No.	Part No.	Description	Schematic Ref. No.	Part No.	Description
	BA04229A	CPU P.C.B. B Ass'y 3rd Version	R124,224	OB05579A	Carbon Resistor 22 ERD-25T J
			R125,225	OB05936A	Carbon Resistor 10 ERD-25T J
			R823,824	OB09305A	Metal Film Resistor 100K SN14K2E F
	OB07881C	CPU P.C.B. B	R825	OB09481A	Metal Film Resistor 536K SN14K2E F
IC101,201	OB06261A	IC μ PD4508BC	R826,853	OB05776A	Carbon Resistor 1M ERD-25T J
802			880		
IC301	OB06216A	IC μ PC4556C	R828,834	OB09216A	Fail Safe Type Resistor 10 RDF-25S J
IC801	OB06264A	IC TC4514BP	835,836		
IC803,808	OB06178A	IC μ PD4011C	837,872		
IC804	OB06143A	IC μ PD4001C	873,874		
IC805	OB06124B	IC RC4558D	875,876		
IC806	OB06223A	IC μ PD4040C	877		
IC807	OB06270A	IC μ PD4069C	R829-833	OB01854A	Carbon Resistor 39K ERD-25T J
IC809	OB06219A	IC μ PD4081C	850		(18 pcs.)
Q101,201	OB06100A	Transistor 2SC945 (A) (18 pcs.)	857-868		
801-807			R849,851	OB01889A	Carbon Resistor 100K ERD-25T J
813-818			852,855		
830,831			902		
832			R854,870	OB01682A	Carbon Resistor 6.8K ERD-25T J
Q102,202	OB06179A	Transistor 2SC1959 (Y)	871,886		
822			R878,900	OB05671A	Carbon Resistor 2.2M ERD-25T J
Q103,203	OB06202A	Transistor 2SA562 (Y)	901		
819			R879	OB05625A	Carbon Resistor 220K ERD-25T J
Q808-812	OB06013A	Transistor 2SA733 (6 pcs.)	R881	OB05676A	Carbon Resistor 390K ERD-25T J
821			R882,885	OB01846A	Carbon Resistor 4.7K ERD-25T J
Q820	OB06069A	Transistor 2SB564	R883,887	OB01857A	Carbon Resistor 1K ERD-25T J
Q823	OB06066A	Transistor 2SD471	R884,888	OB01713A	Carbon Resistor 33 ERD-25T J
D801-815	OB06181A	Silicon Diode 1SS53 (15 pcs.)	R889	OB09536A	Fail Safe Type Resistor 18 ERD-14F J
X801	OB08723A	Crystal 1.68MHz	R890	OB09049A	Fail Safe Type Resistor 22 ERD-14F J
L101,201	OB01434A	Peaking Coil 1.14mH	R895,896	OB01933A	Carbon Resistor 220 ERD-25T J
L102,202	OB06635A	Bias Coil	R897	OB01888A	Carbon Resistor 10K ERD-25T J
L103,203	OB00068A	Trap Coil 10.5mH	R898	OB05627A	Carbon Resistor 330K ERD-25T J
VR101,201	OB07256A	Semi-fixed Volume 10K	R899	OB09531A	Carbon Resistor 2M ERD-25T J
VR801	OB07330A	Semi-fixed Volume 500K	C101,201	OB09411A	PP Capacitor 3300P 100V G
R101,102	OB05621A	Carbon Resistor 120K ERD-25T J	C102,202	OB09410A	PP Capacitor 2200P 100V G
201,202		(42 pcs.)	C103,203	OB09405A	PP Capacitor 0.022 μ 100V G
801-822			C104,204	OB09404A	PP Capacitor 1000P 100V J
827			C105,107	OB09322A	PP Capacitor 330P 100V J
838-846			205,207		
848,869			C106,206	OB09246A	Mica Capacitor 150P 50V J
891-894			C801,802	OB09222A	Electrolytic Capacitor 0.47 μ 50V (LN)
R103,203	OB09435A	Metal Film Resistor 12.1K SN14K2E F	804,805		
R104,204	OB09467A	Metal Film Resistor 162K SN14K2E F	806,807		
R105,205	OB09475A	Metal Film Resistor 316K SN14K2E F	C803	OB05681A	Mylar Capacitor 0.01 μ 50V J
R106,206	OB09482A	Metal Film Resistor 649K SN14K2E F	C808	OB09163A	Electrolytic Capacitor 10 μ 16V (BP)
R107,207	OB05962A	Carbon Resistor 1.2M ERD-25T J	C809	OB09407A	PP Capacitor 0.15 μ 100V J
R108,208	OB09535A	Metal Film Resistor 9.76K SN14K2E F	C810,811	OB01412A	Electrolytic Capacitor 10 μ 16V
R109,209	OB09439A	Metal Film Resistor 20K SN14K2E F	C812,813	OB01502A	Electrolytic Capacitor 330 μ 16V
R110,210	OB09448A	Metal Film Resistor 40.2K SN14K2E F	814,815		
R111,211	OB09459A	Metal Film Resistor 80.6K SN14K2E F	C816	OB01405A	Electrolytic Capacitor 1 μ 50V
R112,212	OB09429A	Metal Film Resistor 7.32K SN14K2E F	C817	OB01780A	Mylar Capacitor 0.1 μ 50V J
R113,114	OB09263A	Carbon Resistor 12K ERD-25T J	CN1,3	OB08646A	10P-T Post
115,116			CN2	OB08655A	11P-T Post
119,213			CN15	OB08642A	6P-T Post
214,215			CN16	OB08643A	7P-T Post
216,219			CN17	OB08724A	5P-T Post
847,856			CN18	OB08656A	2P-T Post
R117,120	OB05615A	Carbon Resistor 22K ERD-25T J	CN19	OB08654A	4P-T Post
217,220			CN20	OB08645A	9P-T Post
R118,218	OB01683A	Carbon Resistor 15K ERD-25T J	CN51	OB08757A	8P-H Connector 250mm
R121,221	OB05629A	Carbon Resistor 2.7K ERD-25T J	CN52	OB08756A	4P-H Connector 180mm
R122,222	OB05575A	Carbon Resistor 560 ERD-25T J	CN54	OB08758A	3P-H Connector 850mm
R123,223	OB09425A	Metal Film Resistor 5.11K SN14K2E F			

Schematic Ref. No.	Part No.	Description	Schematic Ref. No.	Part No.	Description
	BA04229A	CPU P.C.B. B Ass'y 2nd Version	R124,224	OB05579A	Carbon Resistor 22 ERD-25T J
			R125,225	OB05936A	Carbon Resistor 10 ERD-25T J
			R823,824	OB09305A	Metal Film Resistor 100K SN14K2E F
	OB07881B	CPU P.C.B. B	R825	OB09481A	Metal Film Resistor 536K SN14K2E F
IC101,201	OB06261A	IC μ PD4508BC	R826,853	OB05776A	Carbon Resistor 1M ERD-25T J
802			880		
IC301	OB06216A	IC μ PC4556C	R828,834	OB09216A	Fail Safe Type Resistor 10 RDF-25S J
IC801	OB06264A	IC TC4514BP	835,836		
IC803,808	OB06178A	IC μ PD4011C	837,872		
IC804	OB06143A	IC μ PD4001C	873,874		
IC805	OB06124B	IC RC4558D	875,876		
IC806	OB06223A	IC μ PD4040C	877		
IC807	OB06270A	IC μ PD4069C	R829-833	OB01854A	Carbon Resistor 39K ERD-25T J
IC809	OB06219A	IC μ PD4081C	850		(18 pcs.)
Q101,201	OB06100A	Transistor 2SC945 (A) (18 pcs.)	857-868		
801-807			R849,851	OB01889A	Carbon Resistor 100K ERD-25T J
813-818			852,855		
830,831			902		
832			R854,870	OB01682A	Carbon Resistor 6.8K ERD-25T J
Q102,202	OB06179A	Transistor 2SC1959 (Y)	871,886		
822			R878,900	OB05671A	Carbon Resistor 2.2M ERD-25T J
Q103,203	OB06202A	Transistor 2SA562 (Y)	901		
819			R879	OB05625A	Carbon Resistor 220K ERD-25T J
Q808-812	OB06013A	Transistor 2SA733 (6 pcs.)	R881	OB05676A	Carbon Resistor 390K ERD-25T J
821			R882,885	OB01846A	Carbon Resistor 4.7K ERD-25T J
Q820	OB06069A	Transistor 2SB564	R883,887	OB01857A	Carbon Resistor 1K ERD-25T J
Q823	OB06066A	Transistor 2SD471	R884,888	OB01713A	Carbon Resistor 33 ERD-25T J
D801-815	OB06181A	Silicon Diode 1SS53 (15 pcs.)	R889	OB09536A	Fail Safe Type Resistor 18 ERD-14F J
X801	OB08723A	Crystal 1.68MHz	R890	OB09049A	Fail Safe Type Resistor 22 ERD-14F J
L101,201	OB01434A	Peaking Coil 1.14mH	R895,896	OB01933A	Carbon Resistor 220 ERD-25T J
L102,202	OB06635A	Bias Coil	R897	OB01888A	Carbon Resistor 10K ERD-25T J
L103,203	OB00068A	Trap Coil 10.5mH	R898	OB05627A	Carbon Resistor 330K ERD-25T J
VR101,201	OB07256A	Semi-fixed Volume 10K	R899	OB09531A	Carbon Resistor 2M ERD-25T J
VR801	OB07330A	Semi-fixed Volume 500K	C101,201	OB09411A	PP Capacitor 3300P 100V G
R101,102	OB05621A	Carbon Resistor 120K ERD-25T J	C102,202	OB09410A	PP Capacitor 2200P 100V G
201,202		(42 pcs.)	C103,203	OB09405A	PP Capacitor 0.022 μ 100V G
801-822			C104,204	OB09404A	PP Capacitor 1000P 100V J
827			C105,107	OB09322A	PP Capacitor 330P 100V J
838-846			205,207		
848,869			C106,206	OB09246A	Mica Capacitor 150P 50V J
891-894			C801,802	OB09222A	Electrolytic Capacitor 0.47 μ 50V (LN)
R103,203	OB09435A	Metal Film Resistor 12.1K SN14K2E F	804,805		
R104,204	OB09467A	Metal Film Resistor 162K SN14K2E F	806,807		
R105,205	OB09475A	Metal Film Resistor 316K SN14K2E F	C803	OB05681A	Mylar Capacitor 0.01 μ 50V J
R106,206	OB09482A	Metal Film Resistor 649K SN14K2E F	C808	OB09163A	Electrolytic Capacitor 10 μ 16V (BP)
R107,207	OB05962A	Carbon Resistor 1.2M ERD-25T J	C809	OB09407A	PP Capacitor 0.15 μ 100V J
R108,208	OB09535A	Metal Film Resistor 9.76K SN14K2E F	C810,811	OB01412A	Electrolytic Capacitor 10 μ 16V
R109,209	OB09439A	Metal Film Resistor 20K SN14K2E F	C812,813	OB01502A	Electrolytic Capacitor 330 μ 16V
R110,210	OB09448A	Metal Film Resistor 40.2K SN14K2E F	814,815		
R111,211	OB09459A	Metal Film Resistor 80.6K SN14K2E F	C816	OB01405A	Electrolytic Capacitor 1 μ 50V
R112,212	OB09429A	Metal Film Resistor 7.32K SN14K2E F	C817	OB01780A	Mylar Capacitor 0.1 μ 50V J
R113,114	OB09263A	Carbon Resistor 12K ERD-25T J	CN1,3	OB08646A	10P-T Post
115,116			CN2	OB08655A	11P-T Post
119,213			CN15	OB08642A	6P-T Post
214,215			CN16	OB08643A	7P-T Post
216,219			CN17	OB08724A	5P-T Post
847,856			CN18	OB08656A	2P-T Post
R117,120	OB05615A	Carbon Resistor 22K ERD-25T J	CN19	OB08654A	4P-T Post
217,220			CN20	OB08645A	9P-T Post
R118,218	OB01683A	Carbon Resistor 15K ERD-25T J	CN51	OB08757A	8P-H Connector 250mm
R121,221	OB05629A	Carbon Resistor 2.7K ERD-25T J	CN52	OB08756A	4P-H Connector 180mm
R122,222	OB05575A	Carbon Resistor 560 ERD-25T J	CN54	OB08758A	3P-H Connector 850mm
R123,223	OB09425A	Metal Film Resistor 5.11K SN14K2E F			

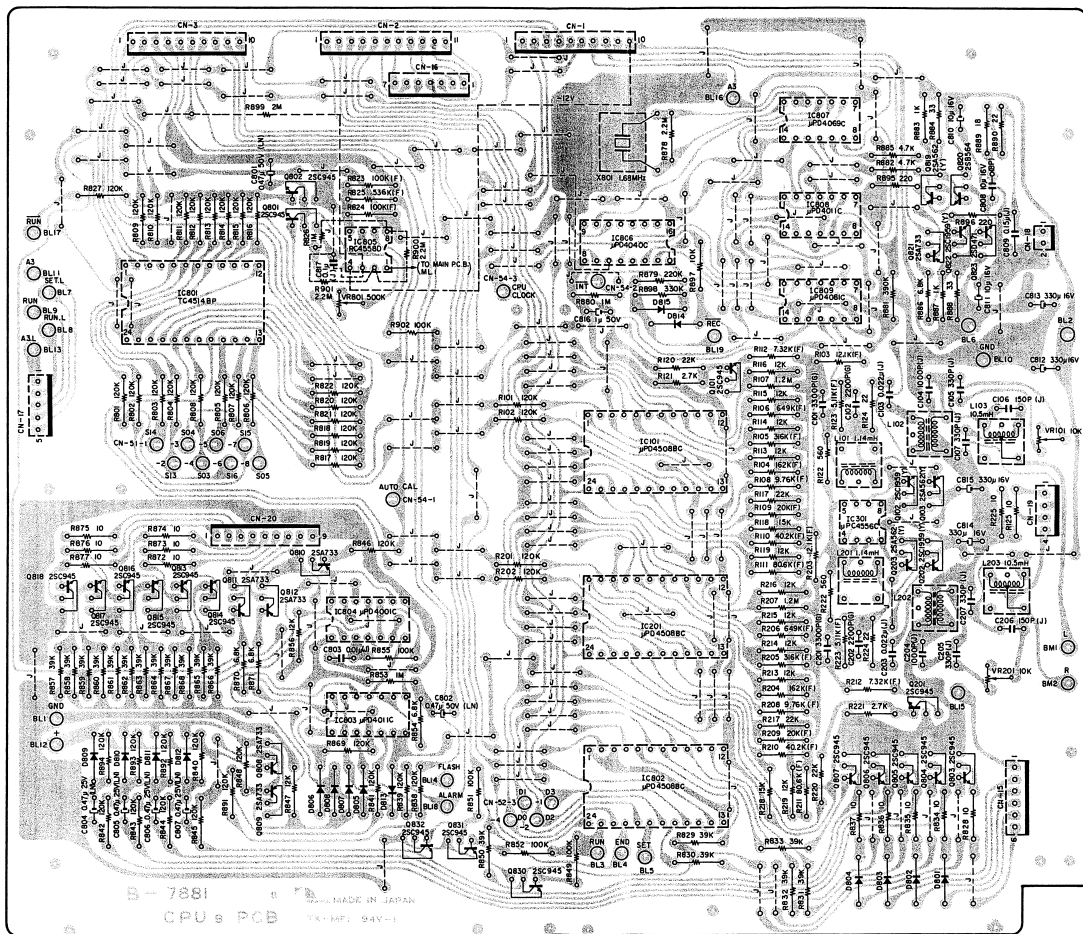

Fig. 7.21.2 2nd Version

Note: Diode is 1SS53 unless otherwise specified.

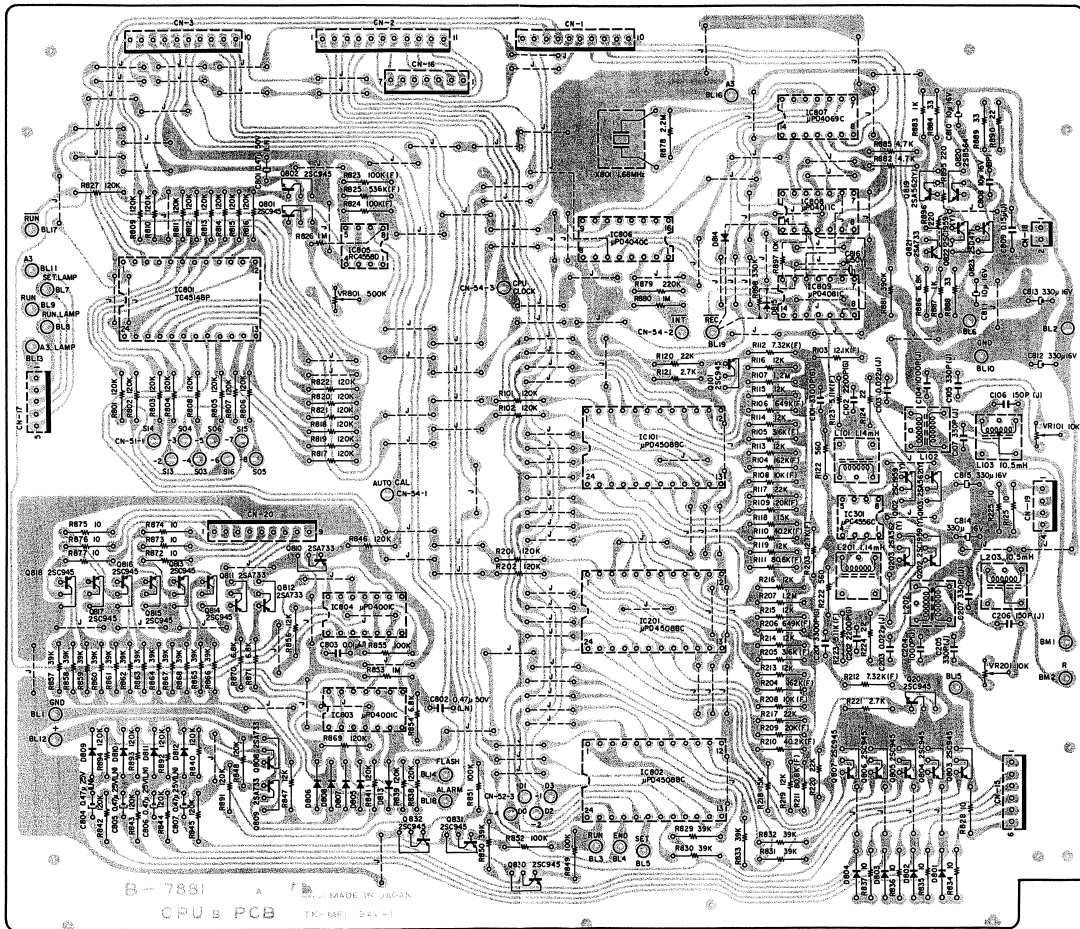

Fig. 7.21. 3 1st Version

Note: Diode is 1SS53 unless otherwise specified.

Schematic Ref. No.	Part No.	Description	Schematic Ref. No.	Part No.	Description
	BA04229A	CPU P.C.B. B Ass'y 1st Version	R124,224	OB05579A	Carbon Resistor 22 ERD-25T J
			R125,225	OB05936A	Carbon Resistor 10 ERD-25T J
			R823,824	OB09305A	Metal Film Resistor 100K SN14K2E F
	OB07881A	CPU P.C.B. B	R825	OB09481A	Metal Film Resistor 536K SN14K2E F
IC101,201	OB06261A	IC μ PD4508BC	R826,853	OB05776A	Carbon Resistor 1M ERD-25T J
802			880		
IC301	OB06216A	IC μ PC4556C	R828,834	OB09216A	Fail Safe Type Resistor 10 RDF-25S J
IC801	OB06264A	IC TC4514BP	835,836		
IC803,808	OB06178A	IC μ PD4011C	837,872		
IC804	OB06143A	IC μ PD4001C	873,874		
IC805	OB06124B	IC RC4558D	875,876		
IC806	OB06223A	IC μ PD4040C	877		
IC807	OB06270A	IC μ PD4069C	R829-833	OB01854A	Carbon Resistor 39K ERD-25T J
IC809	OB06219A	IC μ PD4081C	850		(18 pcs.)
Q101,201	OB06100A	Transistor 2SC945 (A) (18 pcs.)	857-868		
801-807			R849,851	OB01889A	Carbon Resistor 100K ERD-25T J
813-818			852,855		
830,831			R854,870	OB01682A	Carbon Resistor 6.8K ERD-25T J
832			871,886		
Q102,202	OB06179A	Transistor 2SC1959 (Y)	R878	OB05671A	Carbon Resistor 2.2M ERD-25T J
822			R879	OB05625A	Carbon Resistor 220K ERD-25T J
Q103,203	OB06202A	Transistor 2SA562 (Y)	R881	OB05676A	Carbon Resistor 390K ERD-25T J
819			R882,885	OB01846A	Carbon Resistor 4.7K ERD-25T J
Q808-812	OB06013A	Transistor 2SA733 (6 pcs.)	R883,887	OB01857A	Carbon Resistor 1K ERD-25T J
821			R884,888	OB01713A	Carbon Resistor 33 ERD-25T J
Q820	OB06069A	Transistor 2SB564	889		
Q823	OB06066A	Transistor 2SD471	R890	OB09049A	Fail Safe Type Resistor 22 ERD-14F J
D801-815	OB06181A	Silicon Diode 1SS53 (15 pcs.)	R895,896	OB01933A	Carbon Resistor 220 ERD-25T J
X801	OB08723A	Crystal 1.68MHz	R897	OB01888A	Carbon Resistor 10K ERD-25T J
L101,201	OB01434A	Peaking Coil 1.14mH	R898	OB05627A	Carbon Resistor 330K ERD-25T J
L102,202	OB06635A	Bias Coil	C101,201	OB09411A	PP Capacitor 3300P 100V G
L103,203	OB00068A	Trap Coil 10.5mH	C102,202	OB09410A	PP Capacitor 2200P 100V G
VR101,201	OB07256A	Semi-fixed Volume 10K	C103,203	OB09405A	PP Capacitor 0.022 μ 100V G
VR801	OB07330A	Semi-fixed Volume 500K	C104,204	OB09404A	PP Capacitor 1000P 100V J
R101,102	OB05621A	Carbon Resistor 120K ERD-25T J	C105,107	OB09322A	PP Capacitor 330P 100V J
201,202		(42 pcs.)	205,207		
801-822			C106,206	OB09246A	Mica Capacitor 150P 50V J
827			C801,802	OB09222A	Electrolytic Capacitor 0.47 μ 50V (LN)
838-846			804,805		
848,869			806,807		
891-894			C803	OB05681A	Mylar Capacitor 0.01 μ 50V J
R103,203	OB09435A	Metal Film Resistor 12.1K SN14K2E F	C808	OB09163A	Electrolytic Capacitor 10 μ 16V (BP)
R104,204	OB09467A	Metal Film Resistor 162K SN14K2E F	C809	OB09407A	PP Capacitor 0.15 μ 100V J
R105,205	OB09475A	Metal Film Resistor 316K SN14K2E F	C810,811	OB01412A	Electrolytic Capacitor 10 μ 16V
R106,206	OB09482A	Metal Film Resistor 649K SN14K2E F	C812,813	OB01502A	Electrolytic Capacitor 330 μ 16V
R107,207	OB05962A	Carbon Resistor 1.2M ERD-25T J	814,815		
R108,208	OB09203A	Metal Film Resistor 10K SN14K2E F	C816	OB01405A	Electrolytic Capacitor 1 μ 50V
R109,209	OB09439A	Metal Film Resistor 20K SN14K2E F	CN1,3	OB08646A	10P-T Post
R110,210	OB09448A	Metal Film Resistor 40.2K SN14K2E F	CN2	OB08655A	11P-T Post
R111,211	OB09459A	Metal Film Resistor 80.6K SN14K2E F	CN15	OB08642A	6P-T Post
R112,212	OB09429A	Metal Film Resistor 7.32K SN14K2E F	CN16	OB08643A	7P-T Post
R113,114	OB09263A	Carbon Resistor 12K ERD-25T J	CN17	OB08724A	5P-T Post
115,116			CN18	OB08656A	2P-T Post
119,213			CN19	OB08654A	4P-T Post
214,215			CN20	OB08645A	9P-T Post
216,219			CN51	OB08757A	8P-H Connector 250mm
847,856			CN52	OB08756A	4P-H Connector 180mm
R117,120	OB05615A	Carbon Resistor 22K ERD-25T J	CN54	OB08758A	3P-H Connector 850mm
217,220					
R118,218	OB01683A	Carbon Resistor 15K ERD-25T J			
R121,221	OB05629A	Carbon Resistor 2.7K ERD-25T J			
R122,222	OB05575A	Carbon Resistor 560 ERD-25T J			
R123,223	OB09425A	Metal Film Resistor 5.11K SN14K2E F			

Schematic Ref. No.	Part No.	Description	Schematic Ref. No.	Part No.	Description
	BA04226A	RAMM P.C.B. Ass'y	R995	OB05626A	Carbon Resistor 150K ERD-25T J
	OB07894D	RAMM P.C.B.	R996	OB01681A	Carbon Resistor 3.3K ERD-25T J
IC901	OB06245A	IC RAMM CPU μ PD546C-114	C901,902	OB09187A	Electrolytic Capacitor 1 μ 50V (BP)
IC902,903	OB06261A	IC μ PD4508BC	903		
IC904,905	OB06213A	IC TC4013BP	C904,905	OB01412A	Electrolytic Capacitor 10 μ 16V
913			C906	OB05681A	Mylar Capacitor 0.01 μ 50V J
IC906-910	OB06219A	IC μ PD4081C	C907	OB09223A	Electrolytic Capacitor 1 μ 50V (LN)
916,918			C908	OB09393A	Ceramic Capacitor 68P 50V K
IC911	OB06124B	IC RC4558D	C909	OB09282A	Ceramic Capacitor 100P 50V K
IC912	OB06212A	IC TC4510BP	C910,911	OB09286A	Ceramic Capacitor 470P 50V K
IC914	OB06214A	IC μ PD4071C	C912	OB05582A	Mylar Capacitor 0.022 μ 50V J
IC915	OB06224A	IC TC4023BP	C913	OB09333A	Electrolytic Capacitor 4.7 μ 25V (LN)
IC917	OB06270A	IC μ PD4069C	CN24,58	OB08644A	8P-T Post
Q901-927	OB06100A	Transistor 2SC945 (A) (27 pcs.)	59		
D901-932	OB06181A	Silicon Diode 1SS53 (32 pcs.)	CN25,57	OB08642A	6P-T Post
L901	OB06636A	Inductor 1.05mH	CN26	OB08655A	11P-T Post
R901,902	OB09216A	Fail Safe Type Resistor 10 RDF-25S J	CN27	OB08724A	5P-T Post
904,905		(21 pcs.)	CN28	OB08643A	7P-T Post
001-017			CN29,30	OB08732A	12P-S Connector F12P-SHVQ
R903	OB05675A	Carbon Resistor 3.9K ERD-25T J	CN41,56	OB08654A	4P-T Post
R906-908	OB05560A	Carbon Resistor 18K ERD-25T J	CN43	OB08236A	4P-T Post B4P-SHF-1
967-971		(25 pcs.)	CN50	OB08183A	5P-T Post B5P-SHF-1
018-034			CN54	OB08653A	3P-T Post
R909,919	OB01888A	Carbon Resistor 10K ERD-25T J	CN55	OB08656A	2P-T Post
940,941			CN60,61	OB08334A	8P-T Post B8P-SHF-1
942,943					
973,977					
986,998					
R910,911	OB01683A	Carbon Resistor 15K ERD-25T J			
R912-917	OB01889A	Carbon Resistor 100K ERD-25T J			
920-925		(28 pcs.)			
927,928					
930-933					
960,963					
979,980					
983,984					
988,990					
992,037					
R918,926	OB05776A	Carbon Resistor 1M ERD-25T J			
935,972					
981,982					
987,989					
991,993					
035,036					
R929,961	OB05615A	Carbon Resistor 22K ERD-25T J			
R934,962	OB05625A	Carbon Resistor 220K ERD-25T J			
R936,937	OB05622A	Carbon Resistor 2.2K ERD-25T J			
938,939					
997					
R944-955	OB01856A	Carbon Resistor 8.2K ERD-25T J			
035,036		(12 pcs.)			
R956,957	OB05508A	Carbon Resistor 56K ERD-25T J			
958					
R964	OB09392A	Carbon Resistor 200K ERD-25T J			
R965,966	OB05676A	Carbon Resistor 390K ERD-25T J			
R974	OB05641A	Carbon Resistor 47K ERD-25T J			
R975	OB05620A	Carbon Resistor 270K ERD-25T J			
R976,994	OB01857A	Carbon Resistor 1K ERD-25T J			
999					
R978	OB05627A	Carbon Resistor 330K ERD-25T J			
R985	OB05509A	Carbon Resistor 33K ERD-25T J			

7.22. RAMM P.C.B. Ass'y

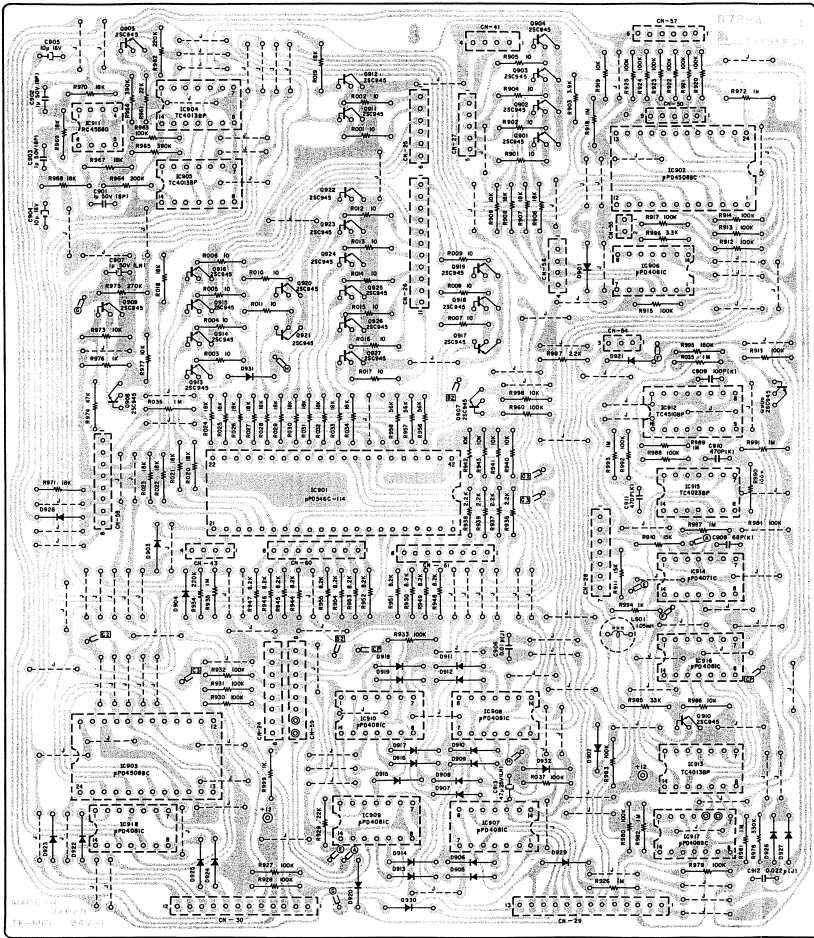

Fig. 7.22

Note: Diode is 1SS53 unless otherwise specified.

7.23. Display P.C.B. Ass'y

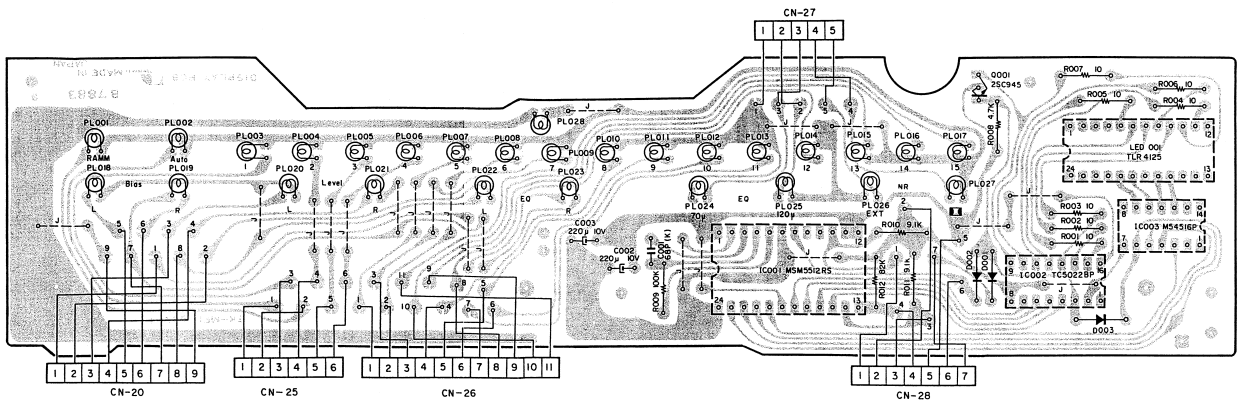

Fig. 7.23

Note: Diode is 1SS53 unless otherwise specified.

Schematic Ref. No.	Part No.	Description
	BA04233A	Display P.C.B. Ass'y
	0807883B	Display P.C.B.
IC001	0806259A	IC MSM5512RS
IC002	0806211A	IC TC5022BP
IC003	0806258A	IC M54516P
Q001	0806100A	Transistor 2SC945 (A)
D001,002	0806181A	Silicon Diode 1SS53
003		
LED001	0806266A	LED TLR4125
R001-007	0805936A	Carbon Resistor 10 ERD-25T J (7 pcs.)
R008	0801846A	Carbon Resistor 4.7K ERD-25T J
R009	0801889A	Carbon Resistor 100K ERD-25T J
R010,011	0805694A	Carbon Resistor 9.1K ERD-25T J
R012	0805668A	Carbon Resistor 82K ERD-25T J
C001	0809033A	Ceramic Capacitor 68P 50V K
C002,003	0805898A	Electrolytic Capacitor 220u 10V
PL001-027	0808721A	Lamp 12V 30mA (27 pcs.)
PL028	0808822A	Lamp 14V 60mA
CN20	0808741A	9P-H Connector 550mm
CN25	0808740A	6P-H Connector 340mm
CN26	0808742A	11P-H Connector 360mm
CN27	0808738A	5P-H Connector 390mm
CN28	0808739A	7P-H Connector 420mm
	0808772A	Filter Cap (1 pct.)

8. MECHANISM ASS'Y AND PARTS LIST

8.1. Synthesis

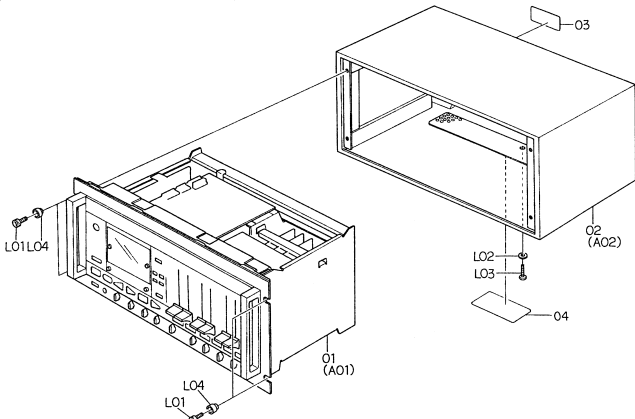

Fig. 8.1

8.2. Synthesis Mechanism Ass'y (A01)

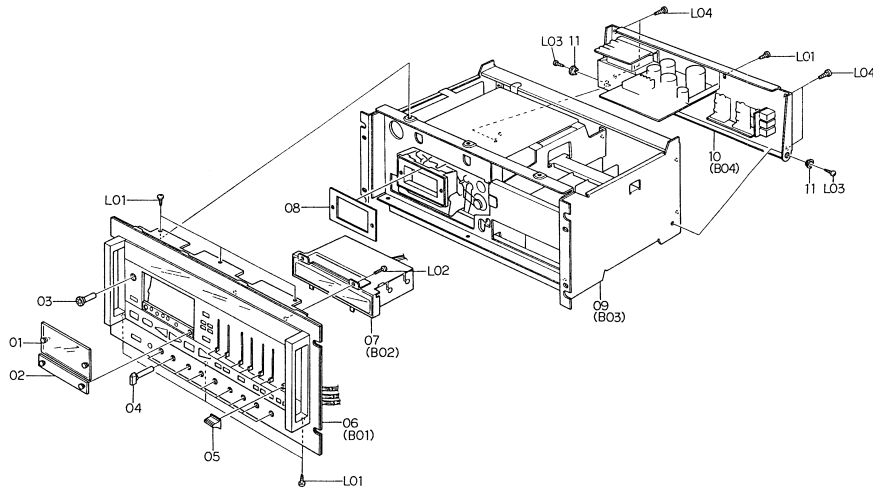

Fig. 8.2

Schematic Ref. No.	Part No.	Description	Q'ty	Schematic Ref. No.	Part No.	Description	Q'ty		
01		Synthesis Serial No.: A11701001--		A01	HA04008A	Synthesis Mechanism Ass'y (U.S.A. & Canada)	1		
					HA04025A	Synthesis Mechanism Ass'y (Japan)	1		
	HA04008A	Synthesis Mechanism Ass'y (U.S.A. & Canada)	1		HA04026A	Synthesis Mechanism Ass'y (Others)	1		
	HA04025A	Synthesis Mechanism Ass'y (Japan)	1		HA04027A	Synthesis Mechanism Ass'y (220V Class 2)	1		
	HA04026A	Synthesis Mechanism Ass'y (Others)	1		HA04028A	Synthesis Mechanism Ass'y (UK)	1		
	HA04027A	Synthesis Mechanism Ass'y (220V Class 2)	1		HA04029A	Synthesis Mechanism Ass'y (Australia)	1		
	HA04028A	Synthesis Mechanism Ass'y (UK)	1			Serial No.: A11701001--			
	HA04029A	Synthesis Mechanism Ass'y (Australia)	1						
	02	HA04000A	Cabinet Ass'y		1	01	HA04001A	Cassette Case Cover Ass'y	1
	03	0M03458A	PASS Label		1	02	HA03981A	Azimuth Alignment Cover Ass'y	1
04	0M04101A	Caution Label	1	03	0H03846A	Pitch Control Knob	1		
L01	0E00932A	Screw M5x10 Hex. Socket Head (Black Chromate)	4	04	0H03860A	Function Switch Knob	3		
L02	0E00930A	Washer 5mm (Black Chromate)	1	05	0H03844A	Slide Volume Knob	9		
L03	0E00931A	Screw M4x18 Philips Binding Head (Bronze)	1	06	HA04009A	Front Panel Ass'y	1		
L04	0H03847A	Set Washer	4	07	HA04011A	FL Indicator Ass'y	1		
				08	0H03838A	Cassette Case Plate	1		
				09	HA04012A	Synthesis Mechanism Sub Ass'y (U.S.A. & Canada)	1		
					HA04030A	Synthesis Mechanism Sub Ass'y (Japan)	1		
					HA04031A	Synthesis Mechanism Sub Ass'y (220V Class 2, UK, Australia & Others)	1		
				10	HA04010A	Rear Panel Ass'y (U.S.A. & Canada)	1		
					HA04035A	Rear Panel Ass'y (Japan)	1		
					HA04036A	Rear Panel Ass'y (Others)	1		
					HA04037A	Rear Panel Ass'y (220V Class 2)	1		
					HA04038A	Rear Panel Ass'y (UK)	1		
					HA04039A	Rear Panel Ass'y (Australia)	1		
				11	0J04154A	Rear Panel Collar	2		
				-	0B08515A	Inst-Lock	5		
				L01	0E00860A	BT Screw M3x6 Philips Binding Head (Black Chromate)	7		
				L02	0E00521A	Screw M3x8 Philips Pan Head	2		
				L03	0E00857A	BT Screw M3x6 Philips Binding Head	2		
				L04	0E00858A	BT Screw M4x6 Philips Binding Head (Bronze)	4		

8.3. Cabinet Ass'y (A02)

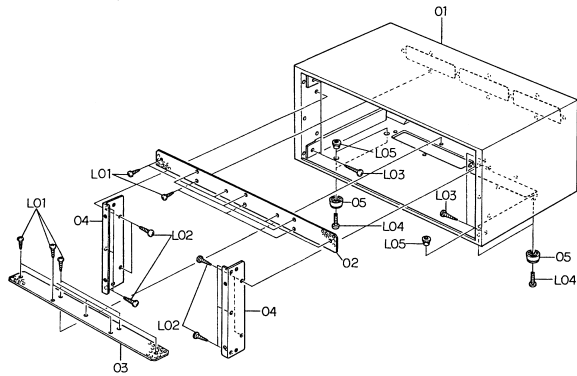

Fig. 8.3

8.4. Front Panel Ass'y (B01)

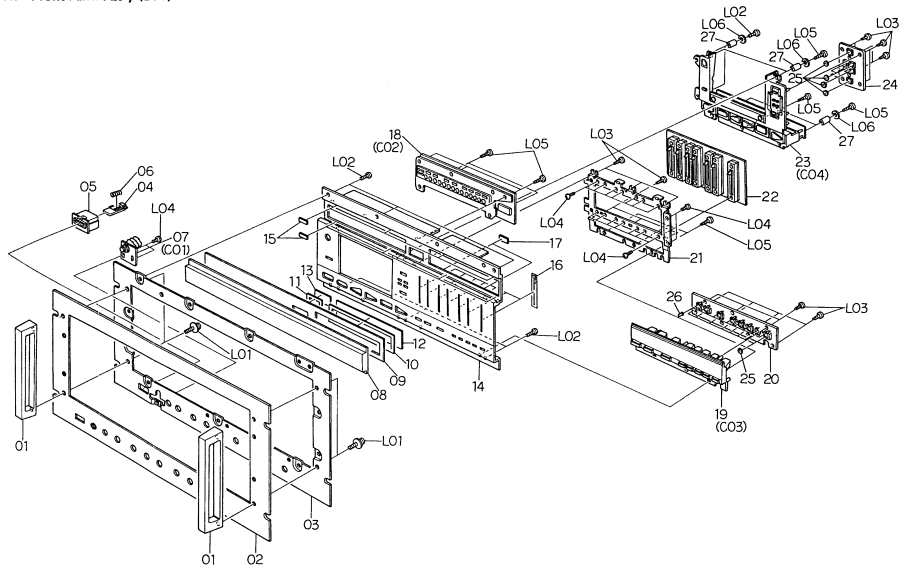

Fig. 8.4

Schematic Ref. No.	Part No.	Description	Q'ty
A02	HA04000A	Cabinet Ass'y Serial No.: A11701001--	1
01	0A03286A	Cabinet	1
02	0H03878A	Punching Plate A	1
03	0H03879A	Punching Plate B	1
04	0H03880A	Cabinet Side Plate	2
05	0J03825A	Leg S	4
L01	0E01022A	Wood Screw 2.7x8 Philips Round Head	17
L02	0E01023A	Wood Screw 3.1x13 Philips Round Head	10
L03	0E01024A	Wood Screw 3.1x25 Philips Round Head	4
L04	0E00937A	Screw M4x16 Philips Pan Head (Black Chromate)	4
L05	0E01025A	Nut 4mm (Self Tightened)	4

Schematic Ref. No.	Part No.	Description	Q'ty	Schematic Ref. No.	Part No.	Description	Q'ty
B01	HA04009A	Front Panel Ass'y Serial No.: A11701001--	1	17	0J04129A	F.L. Indicator Cushion	2
				18	HA04018A	Display House Ass'y	1
				19	HA04016A	Front Escutcheon B Ass'y	1
				20	BA04240A	Function P.C.B. Ass'y	1
01	0H03867A	Handle	2	21	0J04118A	Volume Holder	1
02	0H03871A	Front Panel B	1	22	BA04232A	MIC Amp. & Volume P.C.B. Ass'y	1
03	0J04121A	Panel Chassis	1	23	HA04015A	Front Escutcheon A Ass'y	1
04	0H03863A	Power Switch Button	1	24	BA04241A	RAMM Control Switch P.C.B. Ass'y	1
05	0H03864A	Power Switch Escutcheon	1	25	0J04290B	Switch Cushion	14
06	0J04114A	Power Switch Spring	1	26	0B08847A	Filter Cap G-50	8
07	JA03737A	Headphone Jack Ass'y	1	27	0J04329A	Front Escutcheon Collar	6
08	0H03870A	Indicator Cover	1	L01	0E00933A	Screw M4x12 Philips Pan Head (3A)	4
09	0H03869B	Indicator Plate	1	L02	0E00589A	Screw M3x6 Philips Pan Head	18
10	0J04288A	Adhesive Tape A	1	L03	0E00857A	BT Screw M3x6 Philips Binding Head	19
11	0J04289B	Adhesive Tape B	1	L04	0E00502A	Screw M3x5 Philips Pan Head	18
12	0H03842A	F.L. Indicator Filter	1	L05	0E00868A	BT Screw M3x8 Philips Binding Head	13
13	0H03856B	Counter Filter	1	L06	0E00178A	Washer 3mm	6
14	0H03875B	Front Panel	1				
15	0J04112B	Indicator Cushion	8				
16	0J04128A	Volume Cover	7				

8.5. FL Indicator Ass'y (B02)

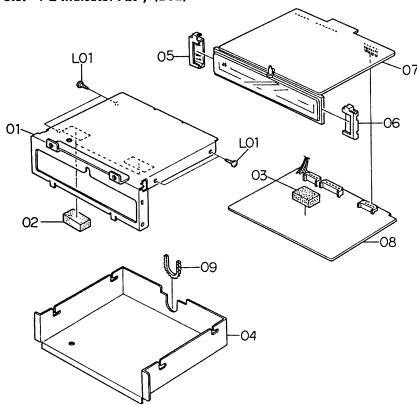

Fig. 8.5

8.6. Synthesis Mechanism Sub Ass'y (B03)

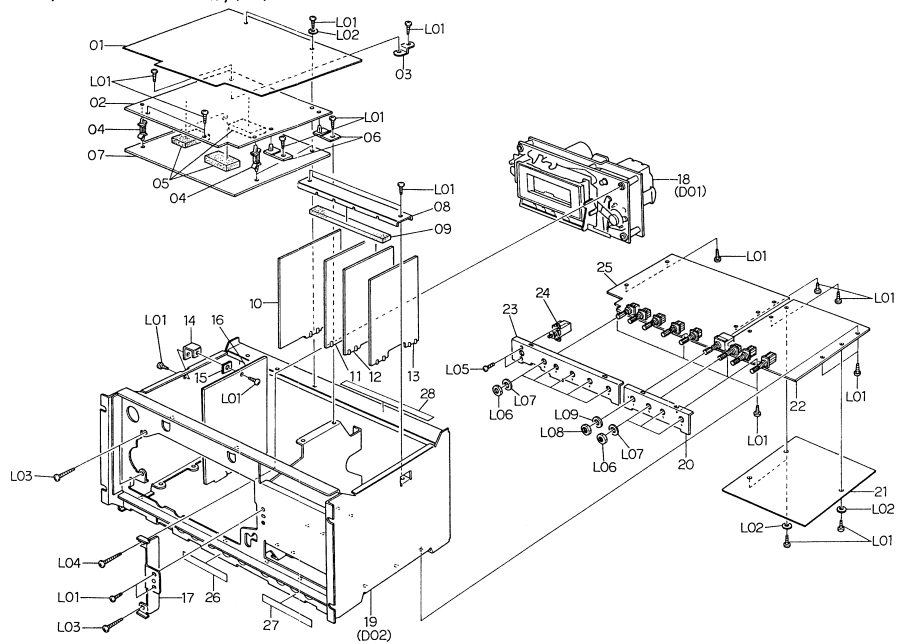

Fig. 8.6

Schematic Ref. No.	Part No.	Description	Q'ty	Schematic Ref. No.	Part No.	Description	Q'ty	Schematic Ref. No.	Part No.	Description	Q'ty	Schematic Ref. No.	Part No.	Description	Q'ty
B02	HA04011A	FL Indicator Ass'y Serial No.: A11701001--	1	B03	HA04012A	Synthesis Mechanism Sub Ass'y Serial No.: A11701001--	1	13	BA04235A	Playback Amp. & Dolby NR P.C.B. Ass'y	1	27	0M04177A	Function Switch Seal R	1
01	JA03683A	FL Indicator Case Ass'y	1	01	0B08824B	CPU P.C.B. Shield Plate	1	14	0J04151B	P.C.B. Ass'y	1	28	0M04179A	Module P.C.B. Indicator Label	1
02	0J04263B	Cushion B	2	02	BA04229A	CPU P.C.B. B Ass'y	1	15	0J04264A	Insulator	1	-	0M04170A	Amplifier Serial No. Seal	1
03	0J04262B	Cushion A	1	03	0J04153A	P.C.B. Holder C	1	16	BA04226A	RAMM P.C.B. Ass'y	1	-	0B08515A	Insh-Lock	30
04	0J04127A	FL Indicator Case Cover	1	04	0J04255A	P.C.B. Supporter	4	17	0J04135C	Mechanism Bracket	1	L01	0E00857A	BT Screw M3x6 Philips Binding Head	28
05	0J04119A	FL Indicator Holder L	1	05	0J04262A	Cushion A	3	18	CA08243B	Mechanism Ass'y 1000ZXL	1	L02	0E00178A	Washer 3mm	5
06	0J04120A	FL Indicator Holder R	1	06	0B08771A	Hinge	2	19	JA03734A	Chassis Sub Ass'y	1	L03	0E00944A	BT Screw M4x15 Philips Binding Head (Block Chromate)	3
07	BA04246A	FL Indicator P.C.B. B Ass'y	1	07	BA04228A	CPU P.C.B. A Ass'y	1	20	0J04146A	Switch Plate MB	1	L04	0E00924A	BT Screw M4x16 Philips Binding Head	1
08	BA04245A	FL Indicator P.C.B. A Ass'y	1	08	0J04152A	P.C.B. Holder B	1	21	0B08825A	Main P.C.B. Ass'y	1	L05	0E00502A	Screw M3x5 Philips Pan Head	2
09	0B08776A	Free Bushing 36mm	1	09	0J04155B	P.C.B. Cushion	1	22	BA04227A	Main P.C.B. Ass'y	1	L06	-	Switch Nut A	(8)
L01	0E00857A	BT Screw M3x6 Philips Binding Head	4	10	BA04231A	Record Eq. Amp. P.C.B. Ass'y	1	23	0J04145A	Switch Plate LB	1	L07	-	Switch Washer A	(8)
				11	BA04230A	Detector P.C.B. Ass'y	1	24	0B07253A	Power Switch	1	L08	-	Switch Nut B	(1)
				12	BA04236A	Record Dolby NR P.C.B. Ass'y	1	25	0B07252A	Power Switch	1	L09	-	Switch Washer B	(1)
								26	BA04244B	Logic P.C.B. Ass'y	1				
									0M04178A	Function Switch Seal L	1				

8.7. Rear Panel Ass'y (B04)

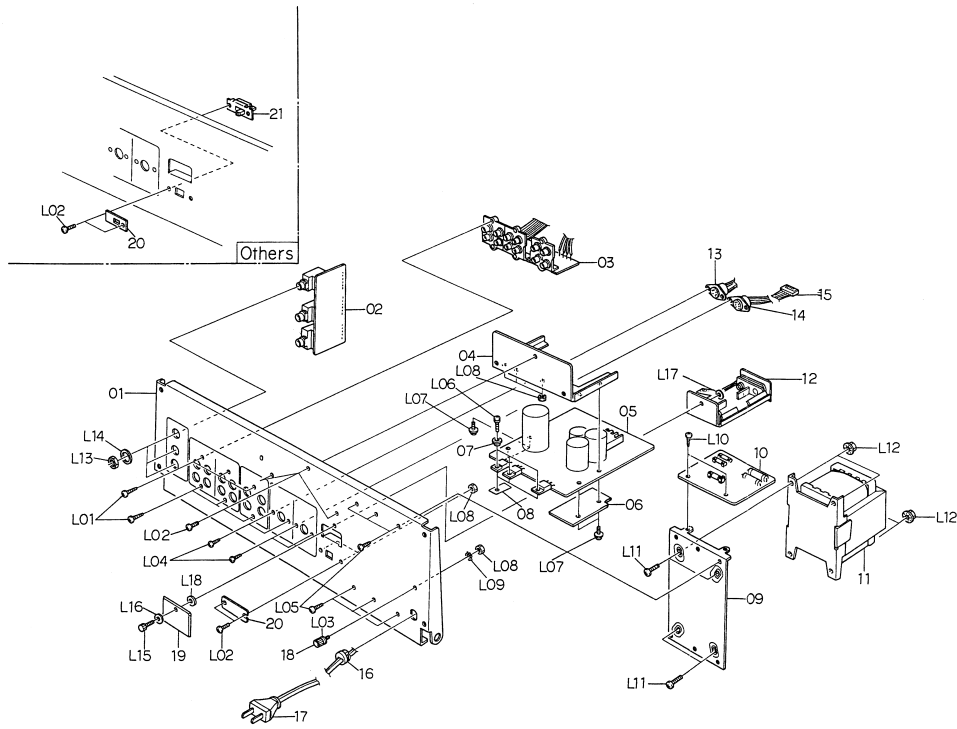

Fig. 8.7

8.8. Headphone Jack Ass'y (C01)

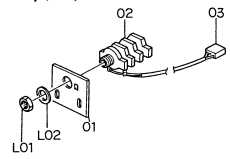

Fig. 8.8

8.9. Display House Ass'y (C02)

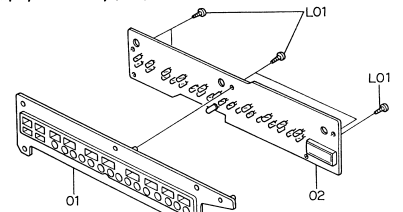

Fig. 8.9

8.10. Front Escutcheon B Ass'y (C03)

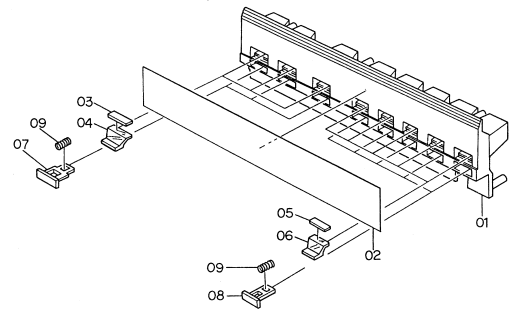

Fig. 8.10

Schematic Ref. No.	Part No.	Description	Q'ty	Schematic Ref. No.	Part No.	Description	Q'ty	
B04	HA04010A	Rear Panel Ass'y (U.S.A. & Canada)	1	L01	0E00921A	BT Screw M3x8 Philips Binding Head (Black Chromate)	6	
	HA04035A	Rear Panel Ass'y (Japan)	1	L02	0E00593A	Screw M3x6 Philips Binding Head	5	
	HA04036A	Rear Panel Ass'y (Others)	1	L03	0E00732A	Washer 3mm	1	
	HA04037A	Rear Panel Ass'y (220V Class 2)	1	L04	0E00714A	Screw M2.6x6 Philips Binding Head (Bronze)	4	
	HA04038A	Rear Panel Ass'y (UK)	1	L05	0E00860A	BT Screw M3x6 Philips Binding Head (Bronze)	6	
	HA04039A	Rear Panel Ass'y (Australia) Serial No.: A11701001-	1	L06	0E00510A	Screw M3x8 Philips Pan Head	3	
				L07	0E00606A	Screw M3x6 Philips Pan Head	4	
				L08	0E00507A	Nut Hex. M3	6	
	01	0H03881D	Rear Panel	1	L09	0E00172A	Washer 3mm Toothed Lock	1
	02	BA04243A	MIC Jack P.C.B. Ass'y	1	L10	0E00857A	BT Screw M3x6 Philips Binding Head	2
	03	BA04242A	Pin Jack P.C.B. Ass'y	1	L11			
04	0B08759C	Heat Sink	1		0E00929A	Screw M4x8 Philips Binding Head	4	
05	BA04234A	Power Supply P.C.B. Ass'y	1	L12	0E00928A	Nut Hex. M4 Flange	4	
06	0B08826B	Insulator	1	L13	-	MIC Jack Nut	(3)	
07	0B08602A	Transistor Bushing TO220	3	L14	-	MIC Jack Washer	(3)	
08	0B08601A	Insulator Mica TO220	3	L15	0H03825B	Screw M3x5 Cylinder Head	1	
09	0J04147B	Transformer Holder	1	L16	0H03760B	Washer A	1	
10	BA04256A	Fuse P.C.B. Ass'y (U.S.A., Canada & Others)	1	L17	0J04067A	Washer FT40	1	
	BA04257A	Fuse P.C.B. Ass'y (Japan)	1	L18	0E00157A	Washer 3mm (Black Plastics)	1	
	BA04259A	Fuse P.C.B. Ass'y (220V Class 2)	1					
	BA04258A	Fuse P.C.B. Ass'y (UK & Australia)	1	C01	JA03737A	Headphone Jack Ass'y Serial No.: A11701001-	1	
11	0B06630A	Power Transformer (U.S.A. & Canada)	1	01	0J04110A	Headphone Jack Holder	1	
	0B06631A	Power Transformer (Japan)	1	02	0B08511A	Headphone Jack	1	
	0B06633A	Power Transformer (Others)	1	03	0B08765A	3P-H Connector	1	
	0B06632A	Power Transformer (220V Class 2, UK & Australia)	1	L01	-	Headphone Jack Nut	(1)	
				L02	-	Headphone Jack Washer	(1)	
12	JA03733A	Battery Box Ass'y	1	C02	HA04018A	Display House Ass'y Serial No.: A11701001-	1	
13	0B08584A	8P DIN Socket	1					
14	0B08495A	8P DIN Socket	1	01	0H03866B	Display House	1	
15	0B08770A	8P-H Connector	1	02	BA04233A	Display P.C.B. Ass'y	1	
16	0B08037U	Cord Bushing (U.S.A., Canada, 220V Class 2, Others, Australia & Japan)	1	L01	0E00857A	BT Screw M3x6 Philips Binding Head	5	
	0B08351A	Cord Bushing (UK)	1					
17	0B08533A	Power Cord (U.S.A., Canada & Others)	1	C03	HA04016A	Front Escutcheon B Ass'y Serial No.: A11701001-	1	
	0B08219B	Power Cord (Japan)	1	01	0H03872B	Front Escutcheon B	1	
	0B08093U	Power Cord (220V Class 2)	1	02	0J04117A	Light Intercepting Reflector	1	
	0B08348A	Power Cord (UK)	1	03	0H03840A	Filter Blue A	3	
	0B05241A	Power Cord (Australia)	1	04	0H03849B	Indicator B	3	
18	0B03920B	Ground Terminal	1	05	0H03841A	Filter Blue B	5	
19	0H03882A	Battery Cover	1	06	0H03848B	Indicator A	5	
20	0J03663C	Switch Cover C (U.S.A., Canada, 220V Class 2, Australia & Japan)	1	07	0H03862A	Function Button B	3	
	0M03946A	Voltage Lock Plate (Others)	1	08	0H03861A	Function Button A	5	
21	0B07092U	Voltage Selector	1	09	0J04115B	Function Switch Spring	8	
-	0M03955A	Voltage Label B (Others)	1					
-	0M03794A	Voltage Label 100V (Japan)	1					
-	0M03796A	Voltage Label 220V (220V Class 2)	1					
-	0M03797A	Voltage Label 240V (UK & Australia)	1					
-	0M03798A	Nakamichi Label (Japan)	1					
-	0M03844B	Power Cord Label (UK)	1					
-	0F01071A	Free-Up Belt	1					
-	0M04203A	ABLE Level (U.S.A.)	1					

8.11. Front Escutcheon A Ass'y (C04)

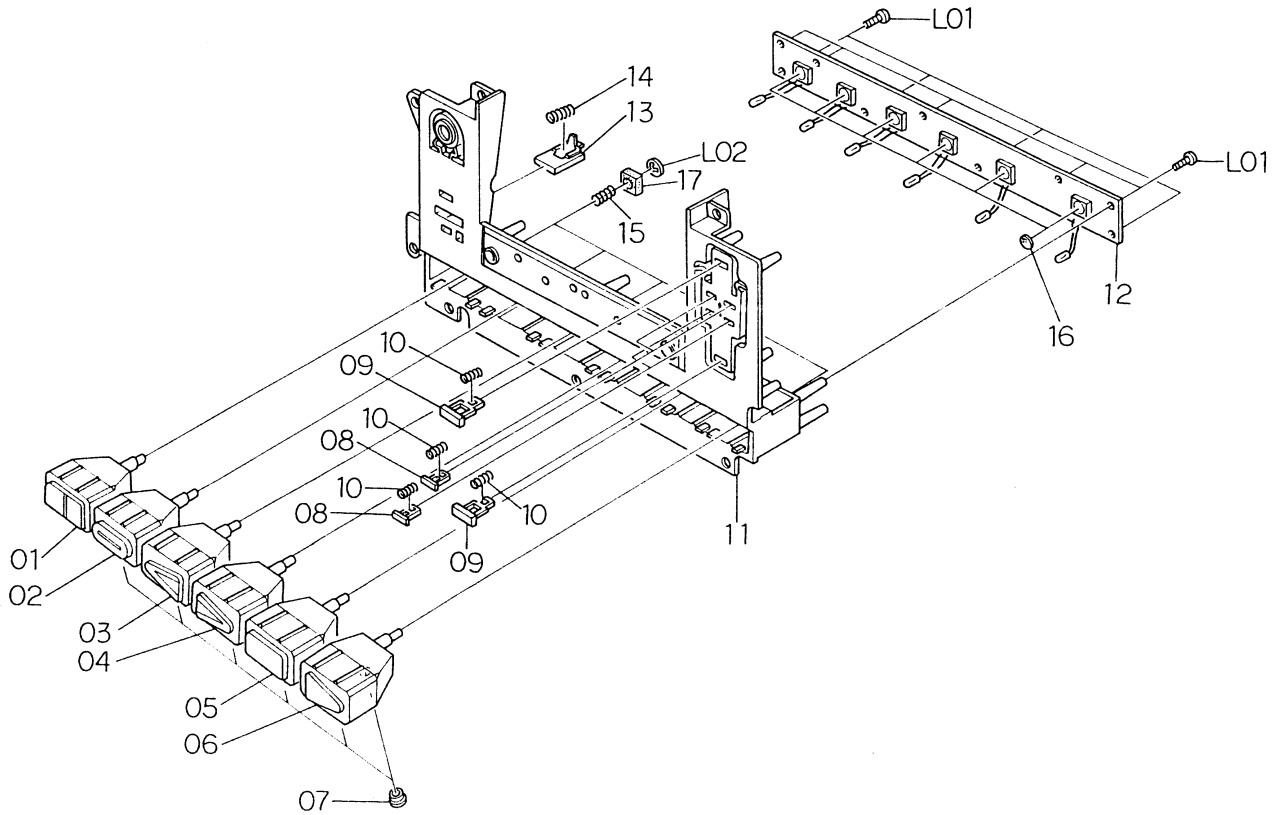

Fig. 8.11

Schematic Ref. No.	Part No.	Description	Q'ty
C04	HA04015A	Front Escutcheon A Ass'y Serial No.: A11701001-	1
01	HA04002A	Pause Button Ass'y	1
02	HA04003A	Record Button Ass'y	1
03	HA04004A	Rewind Button Ass'y	1
04	HA04005A	F.F. Button Ass'y	1
05	HA04006A	Stop Button Ass'y	1
06	HA04007A	Play Button Ass'y	1
07	OJ04109A	Lamp Holder	6
08	OH03861A	Function Button A	4
09	OH03862A	Function Button B	2
10	OJ04115B	Function Switch Spring	6
11	HA03998B	Front Escutcheon A Sub Ass'y	1
12	BA04239A	Mechanism Control Switch P.C.B. Ass'y	1
13	OH03865A	Eject Button	1
14	OJ04114A	Power Switch Spring	1
15	OJ04113B	Control Switch Spring	6
16	OJ04290B	Switch Cushion	6
17	OJ04296A	Button Cushion	6
L01	0E00857A	Screw M3x6 Philips Binding Head	9
L02	0E00926A	Stopper Ring CS 4mm	6

8.12. Mechanism Ass'y 1000ZXL (D01)

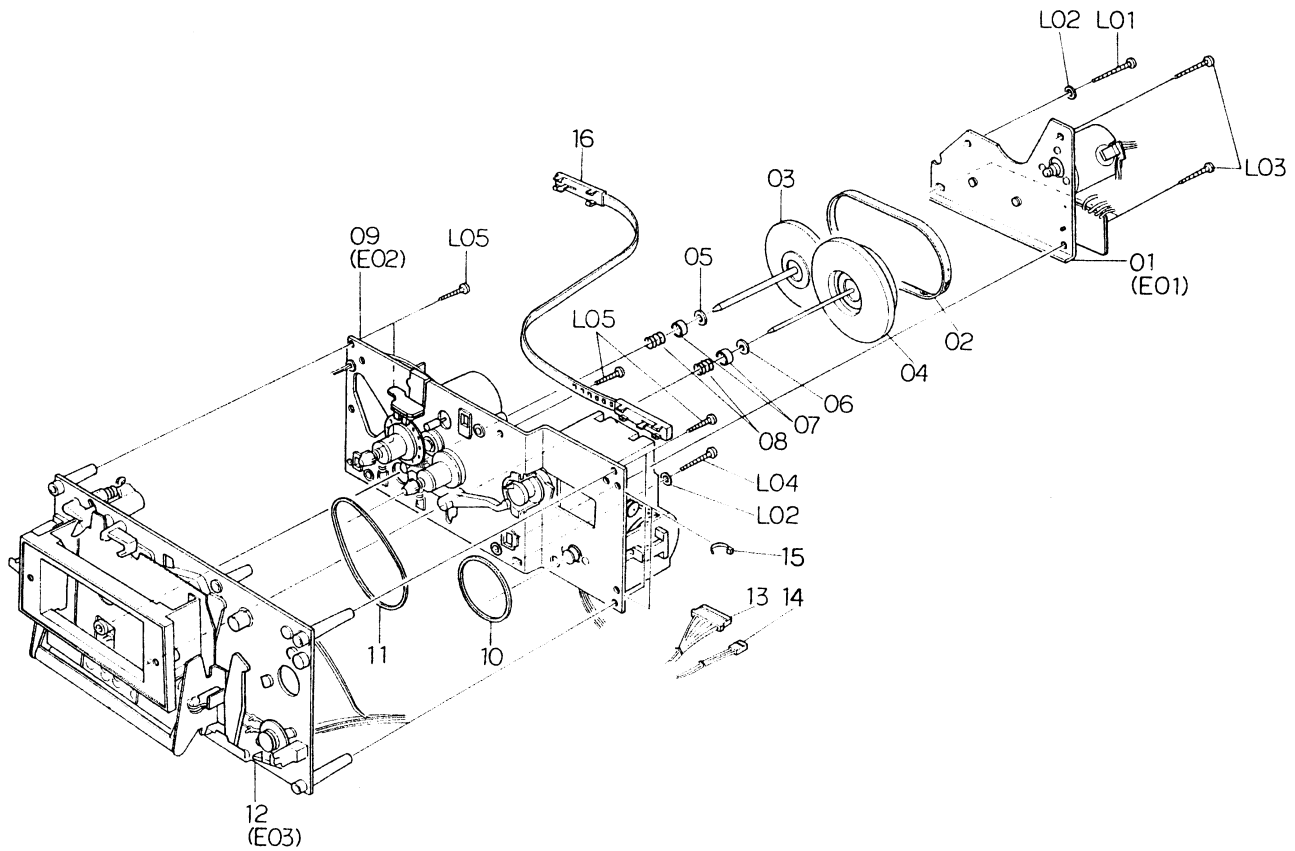

Fig. 8.12

Schematic Ref. No.	Part No.	Description	Q'ty	Schematic Ref. No.	Part No.	Description	Q'ty
D01	CA08243B	Mechanism Ass'y 1000ZXL Serial No.: A11701001-	1	L03	0E00833A	BT Screw M3x20 Philips Pan Head	3
				L04	0E00835A	BT Screw M3x25 Philips Pan Head	1
01	CA08247A	Flywheel Holder Ass'y	1	L05	0E00883A	BT Screw M3x18 Philips Pan Head	5
02	0C08096C	Capstan Belt	1				
03	CA08173A	Supply Flywheel Ass'y	1				
04	CA08015A	Take-up Flywheel Ass'y	1				
05	0C08021B	Thrust Washer 3.1	1				
06	0C08020B	Thrust Washer 2.6	1				
07	0C08244A	Flange Thrust Cap	2				
08	0C08243A	Flange Thrust Spring	2				
09	CA08245A	Sub Mechanism Chassis Ass'y	1				
10	0C08099B	Control Motor Belt	1				
11	0C08098B	Counter Belt B	1				
12	CA08241A	Main Mechanism Chassis Ass'y	1				
13	0B08844A	10P-H Connector	1				
14	0B08652C	3P-H Connector	1				
15	0B08515A	Insh-Lock	16				
16	0C08237A	Azimuth Alignment Wire	1				
-	0M04169A	Mechanism Serial No. Seal	1				
L01	0E00834A	BT Screw M3x30 Philips Pan Head	1				
L02	0E00178A	Washer 3mm	2				

8.13. Chassis Sub Ass'y (D02)

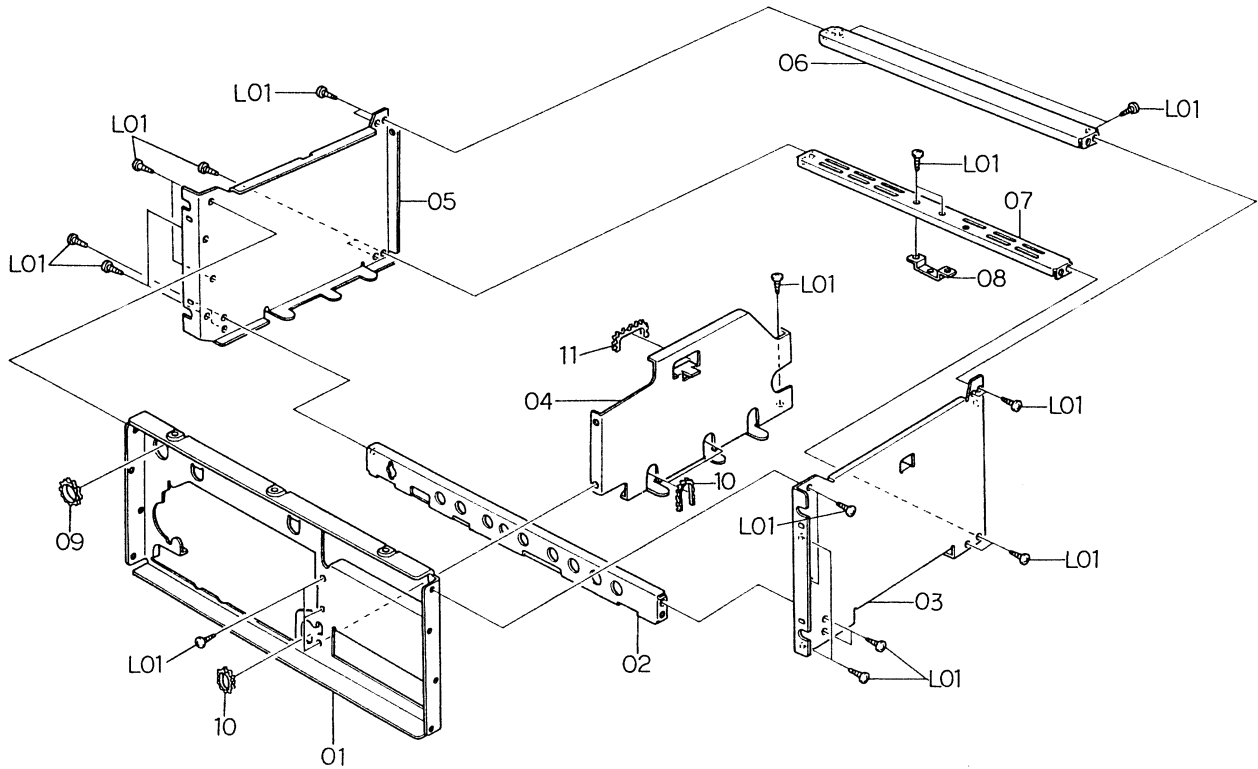

Fig. 8.13

Schematic Ref. No.	Part No.	Description	Q'ty
D02	JA03734A	Chassis Sub Ass'y Serial No.: A11701001-	1
01	OJ04138B	Front Chassis	1
02	OJ04143A	Switch Plate Holder	1
03	OJ04140C	Side Chassis R	1
04	OJ04144C	Center Chassis	1
05	OJ04139C	Side Chassis L	1
06	OJ04142B	Top Plate	1
07	OJ04141A	Bottom Plate	1
08	OJ04150A	Cabinet Holder	1
09	0B08774A	Free Bushing 74mm	1
10	0B08775A	Free Bushing 67mm	3
11	0B08773A	Free Bushing 91mm	1
L01	0E00857A	BT Screw M3x6 Philips Binding Head	28
E01	CA08247A	Flywheel Holder Ass'y Serial No.: A11701001-	1
01	0C08013I	Flywheel Holder	1
02	0C08271A	Capstan Motor	1
03	0C08079G	Capstan Motor Pulley	1
04	BA04238A	Speed Cal. P.C.B. Ass'y	1
L01	0E00226A	Screw M2.6x4 Philips Pan Head	3
L02	0C08068C	Thrust Screw	2
L03	0C03857A	Lock Nut	2
L04	0E00843A	Screw M3x5 Philips Pan Head	1

8.14. Flywheel Holder Ass'y (E01)

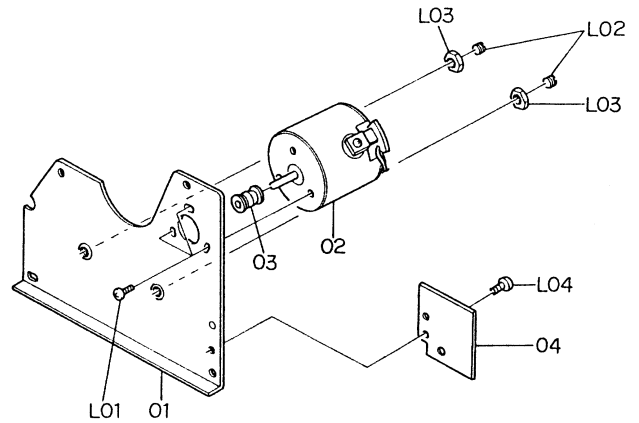

Fig. 8.14

8.15. Sub Mechanism Chassis Ass'y (E02)

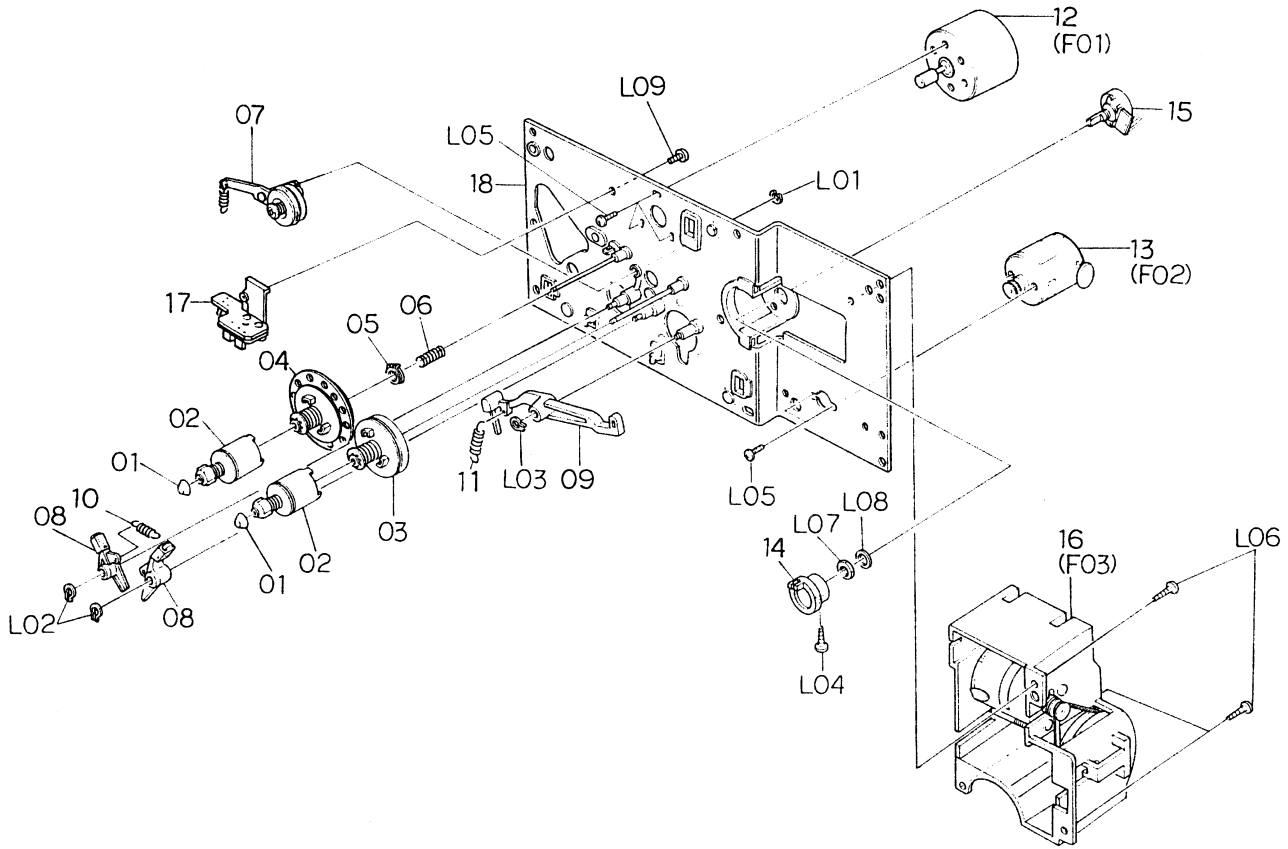

Fig. 8.15

Schematic Ref. No.	Part No.	Description	Q'ty	Schematic Ref. No.	Part No.	Description	Q'ty
E02	CA08245A	Sub Mechanism Chassis Ass'y Serial No.: A11701001—	1	L04	0E00859A	BT Screw M2.6x6 Philips Binding Head	1
				L05	0E00226A	Screw M2.6x4 Philips Pan Head	5
				L06	0E00846A	BT Screw M3x8 Philips Pan Head	3
01	0C08039B	Reel Hub Head	2	L07	—	Volume Nut	(1)
02	CA08038C	Reel Hub B Ass'y	2	L08	—	Volume Washer	(1)
03	CA08037A	Reel Hub Take-up Ass'y	1	L09	0E00792A	BT Screw M2.6x6 Philips Pan Head	1
04	CA08236A	Reel Hub Supply Ass'y	1				
05	CA08039A	Back Tension Ass'y	1				
06	0C08269A	Back Tension Spring	1				
07	CA08193A	Idler Ass'y	1				
08	CA08042A	Brake Ass'y	2				
09	0C08030C	Brake Drive Arm	1				
10	0C08129A	Brake Arm Spring	1				
11	0C08128A	Brake Drive Arm Spring	1				
12	CA08242A	Reel Motor Ass'y	1				
13	CA08034A	Control Motor Ass'y	1				
14	0C08053B	Volume Coupler	1				
15	0B07240A	Volume Control 10kΩ (B)	1				
16	CA08148A	Azimuth Alignment Motor Ass'y	1				
17	BA04237B	Counter Pulse Generator P.C.B. Ass'y	1				
18	CA08194A	Sub Chassis Ass'y	1				
L01	0E00698A	E-Ring 2.5mm	1				
L02	0E00837A	Stopper Ring 3mm	2				
L03	0E00838A	Stopper Ring 4mm	1				

Schematic Ref. No.	Part No.	Description	Q'ty	Schematic Ref. No.	Part No.	Description	Q'ty
E03	CA08241A	Main Mechanism Chassis Ass'y Serial No.: A11701001-	1	L14	0E00859A	BT Screw M2.6x6 Philips Binding Head	1
				L15	0E00255A	Washer 2.6mm	1
01	CA08239A	Cassette Case Holder L Ass'y	1				
02	0C08151A	Lid Arm Spring Tube	1				
03	CA08022A	Cassette Case Holder R Ass'y	1				
04	CA08240A	Cassette Case Ass'y	1				
05	CA08259A	Cover Plate Ass'y	1				
06	CA08248A	Head Mount Base Ass'y	1				
07	0C08121A	Supply Pressure Roller Spring	1				
08	0C08250A	Supply Pressure Roller Spring B	1				
09	CA08053B	Supply Pressure Roller Ass'y	1				
10	0C08122B	Supply Pressure Roller Thrust Spring	1				
11	CA08079B	Take-up Pressure Roller Ass'y	1				
12	0C08183B	Take-up Pressure Roller Thrust Spring	1				
13	CA08250A	Head Base Ass'y E	1				
14	0C08182A	Pressure Roller Drive Bar B	1				
15	0C08086B	Head Base Roller	3				
16	0C08050B	Record Sensor	1				
17	0C08051E	Cassette Hold Arm	1				
18	0C08120A	Cassette Hold Spring	1				
19	CA08196A	Back Tension Arm Ass'y	1				
20	0C08254A	Tension Arm Collar	1				
21	CA08027A	Head Base Drive Arm Ass'y	1				
22	0C08143C	Head Base Drive Arm Spring	1				
23	CA08026A	Pressure Roller Drive Arm Ass'y	1				
24	CA08237A	Auto Shut-off Ass'y	1				
25	0C08119A	Record Protector	1				
26	0C08194C	Damper Lock Arm	1				
27	0C08153A	Damper Lock Arm Spring Tube	1				
28	0C08116A	Record Arm Spring	2				
29	CA08030A	Pneumatic Damper Ass'y	1				
30	CA08291A	Supply Capstan Flange Ass'y	1				
31	CA08292A	Take-up Capstan Flange Ass'y	1				
32	0C08186A	Cam Drive Gear	1				
33	0C08029H	Control Cam	1				
34	0C08117A	Counter-Load Arm Spring	1				
35	0C08152A	Counter-Load Arm Spring Tube	1				
36	CA08028A	Counter-Load Arm Ass'y	1				
37	CA08183A	Main Chassis Ass'y	1				
L01	0E00837A	Stopper Ring 3mm	9				
L02	0E00832A	BT Screw M3x14 Philips Pan Head	2				
L03	0E00834A	BT Screw M3x30 Philips Pan Head	2				
L04	0E00831A	BT Screw M3x10 Philips Pan Head	3				
L05	0E00254A	Washer 3.1mm (Plastics)	2				
L06	0E00222A	E-Ring 2mm	2				
L07	0E00876A	BT Screw M2.6x8 Philips Pan Head	8				
L08	0C08060B	Height Adjustment Nut	2				
L09	0E00142A	Washer 2.6mm	2				
L10	0E00879A	BT Screw M2x15 Philips Pan Head	1				
L11	0E00838A	Stopper Ring 4mm	3				
L12	0E00846A	BT Screw M3x8 Philips Pan Head	3				
L13	0E00895A	Earth Lug 3mm	2				

8.16. Main Mechanism Chassis Ass'y (E03)

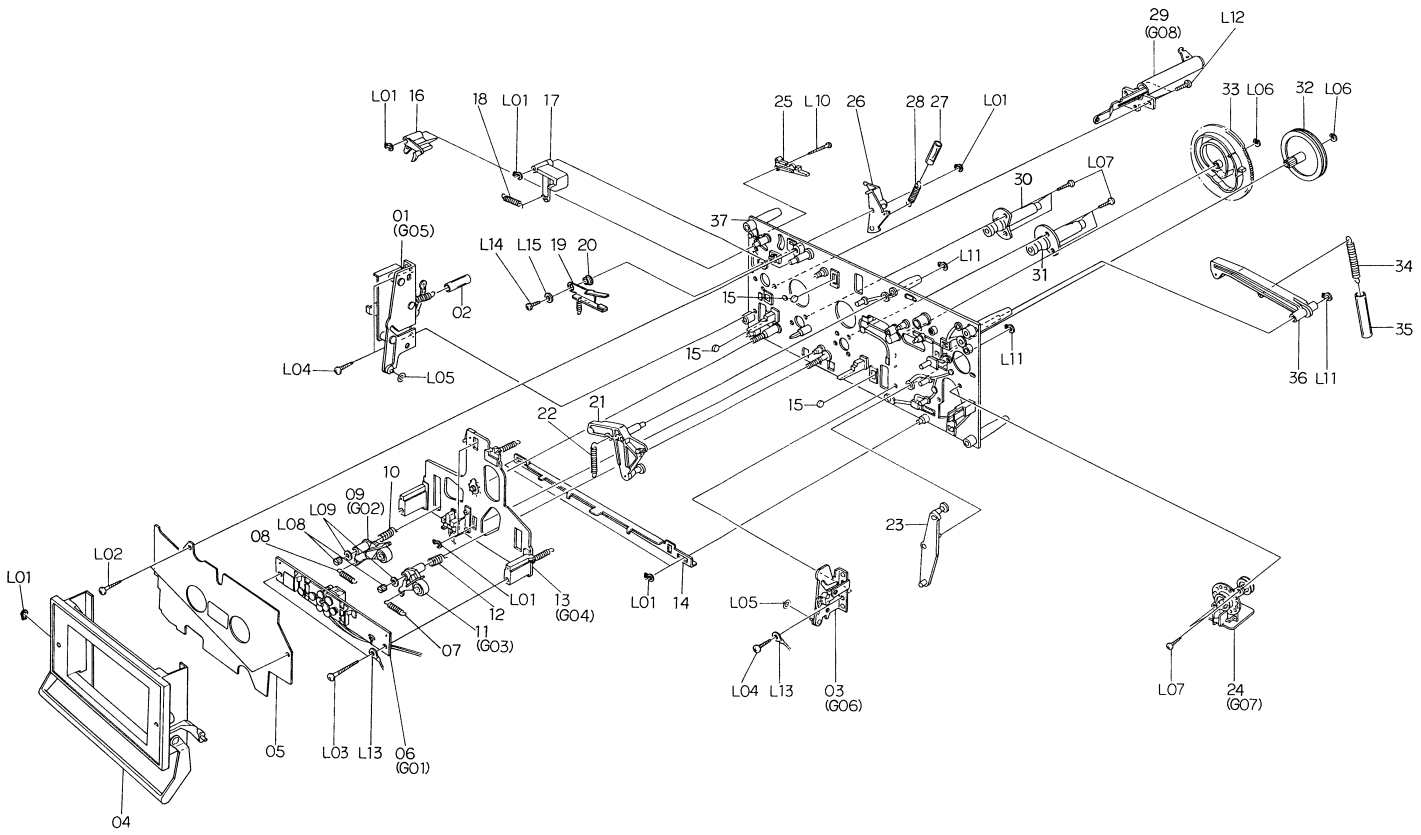

Fig. 8.16

8.17. Reel Motor Ass'y (F01)

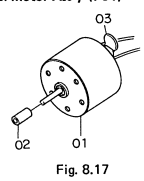

Fig. 8.17

8.18. Control Motor Ass'y (F02)

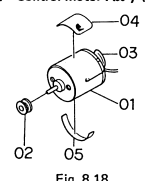

Fig. 8.18

8.19. Azimuth Alignment Motor Ass'y (F03)

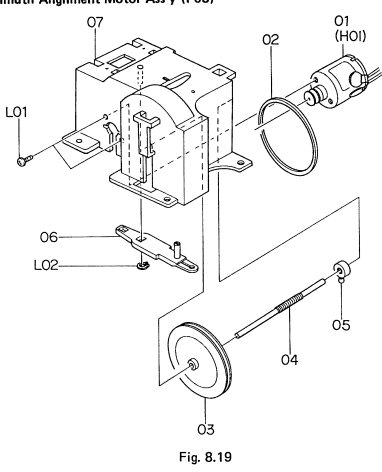

Fig. 8.19

8.20. Head Mount Base Ass'y (G01)

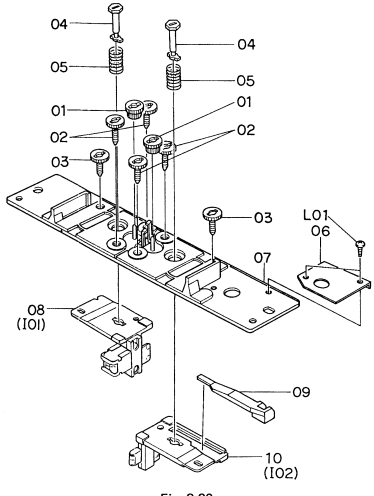

Fig. 8.20

8.21. Supply Pressure Roller Ass'y (G02)

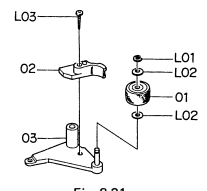

Fig. 8.21

8.22. Take-up Pressure Roller Ass'y (G03)

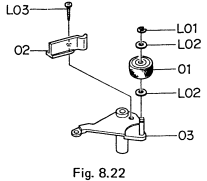

Fig. 8.22

8.23. Head Base Ass'y E (G04)

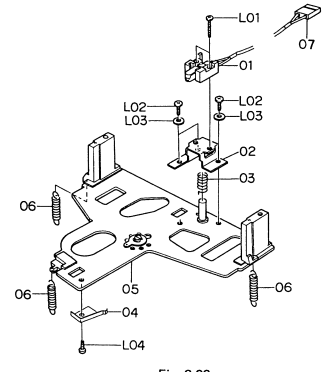

Fig. 8.23

8.24. Cassette Case Holder L Ass'y (G05)

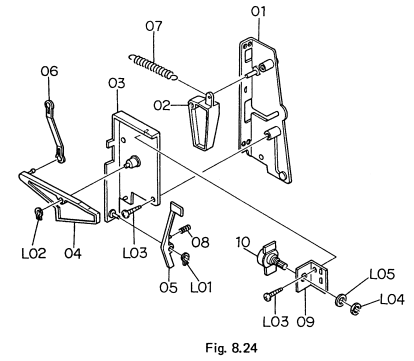

Fig. 8.24

8.25. Cassette Case Holder R Ass'y (G06)

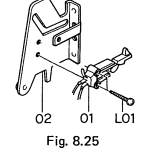

Fig. 8.25

Schematic Ref. No.	Part No.	Description	Q'ty	Schematic Ref. No.	Part No.	Description	Q'ty
F01	CA08242A	Reel Motor Ass'y Serial No.: A11701001-	1	G03	CA08079A	Take-up Pressure Roller Ass'y Serial No.: A11701001-	1
01	0C08272A	Reel Motor	1	01	0C08164G	Pressure Roller	1
02	0C08063F	Reel Motor Pulley	1	02	0C08181C	Take-up Tape Guide	1
03	0B09290A	Ceramic Capacitor 0.01μ 50V Z	1	03	CA08073B	Take-up Pressure Roller Arm Ass'y	1
F02	CA08034A	Control Motor Ass'y Serial No.: A11701001-	1	L01	0E00042A	E-Ring 1.5mm	1
01	0C08137A	Control Motor	1	L02	0C08024A	Washer 2mm	2
02	0C08064A	Control Motor Pulley	1	L03	0E00788A	BT Screw M2x8 Philips Pan Head	1
03	0B09292A	Ceramic Capacitor 0.1μ 50V Z	1	G04	CA08250A	Head Base Ass'y E Serial No.: A11701001-	1
04	0M03985A	Motor Label 730	1	01	GA02083A	E-8LH Erase Head	1
05	0M03988A	Motor Seal B	1	02	0C08158D	EH Hold Plate	1
F03	CA08148A	Azimuth Alignment Motor Ass'y Serial No.: A11701001-	1	03	0C08166A	EH Hold Plate Spring	1
01	CA08149A	Azimuth Motor Ass'y	1	04	0C08174C	Cassette Hold Spring	1
02	0C08099B	Control Motor Belt	1	05	CA08003P	Head Base Ass'y	1
03	0C08229B	Drive Pulley	1	06	0C08175A	Head Base L Spring	3
04	0C08230B	Drive Pulley Shaft	1	07	0B08764A	2P-H Connector	1
05	0C08231C	Drive Nut	1	L01	0E00889A	Screw M1.7x8 Philips Pan Head	2
06	0C08232C	Drive Bar	1	L02	0E00909A	Screw M2x6 Philips Pan Head	3
07	0C08233G	Drive Unit Base	1	L03	0E00117A	Washer 2mm	3
L01	0E00226A	Screw M2.6x4 Philips Pan Head	2	L04	0E00853A	BT Screw M2x3 Philips Pan Head	1
L02	0E00837A	Stopper Ring 3mm	1	G05	CA08239A	Cassette Case Holder L Ass'y Serial No.: A11701001-	1
G01	CA08248A	Head Mount Base Ass'y Serial No.: A11701001-	1	01	CA08090F	Cassette Case L Sub Ass'y	1
01	0C08028C	Head Height Adjustment Gear	2	02	0C08073C	Lid Arm A	1
02	0C08027E	Head Height Adjustment Screw	4	03	0C08195G	Arm Holder	1
03	0C08026D	Azimuth Alignment Screw	2	04	0C08245A	Eject Arm A	1
04	0C08161B	Spring Stopper	2	05	0C08197C	Eject Arm B	1
05	0C08187B	Head Plate Spring	2	06	0C08199B	Eject Arm Joint	1
06	0C08236A	Azimuth Alignment Wire Hold Plate	1	07	0C08114A	Lid Arm Spring	1
07	CA08083C	Head Mount Base Sub Ass'y	1	08	0C08211C	Eject Arm Spring	1
08	CA08244A	P-8L Playback Head Ass'y	1	09	0C08248B	Pitch Control Volume Holder	1
09	0C08235A	Azimuth Alignment Plate	1	L01	0B07282A	Volume Control 20kΩ (B)	1
10	CA08238A	R-8L Record Head Ass'y	1	L02	0E00837A	Stopper Ring 3mm	1
L01	0E00917A	BT Screw M2.6x5 Philips Pan Head	2	L03	0E00838A	Stopper Ring 4mm	1
G02	CA08053B	Supply Pressure Roller Ass'y Serial No.: A11701001-	1	L04	0E00865A	BT Screw M3x10 Philips Binding Head	2
01	0C08164G	Pressure Roller	1	L05	-	Volume Nut	(1)
02	0C08189B	Supply Tape Guide	1	L05	-	Volume Washer	(1)
03	CA08061A	Supply Pressure Roller Arm Ass'y	1	G06	CA08022A	Cassette Case Holder R Ass'y Serial No.: A11701001-	1
L01	0E00042A	E-Ring 1.5mm	1	01	0C08133A	Eject Sensor	1
L02	0C08024A	Washer 2mm	2	02	CA08044A	Cassette Case Holder R Sub Ass'y	1
L03	0E00788A	BT Screw M2x8 Philips Pan Head	1	L01	0E00840A	BT Screw M2x8 Philips Pan Head	2

8.26. Auto Shut-off Ass'y (G07)

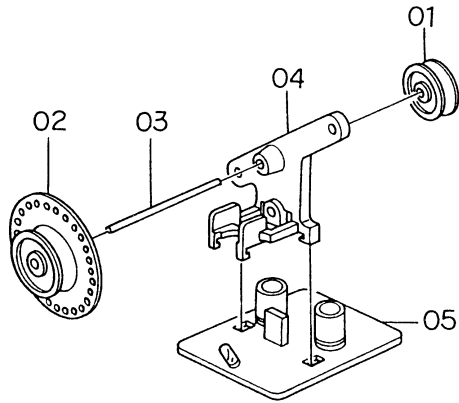

Fig. 8.26

8.27. Pneumatic Damper Ass'y (G08)

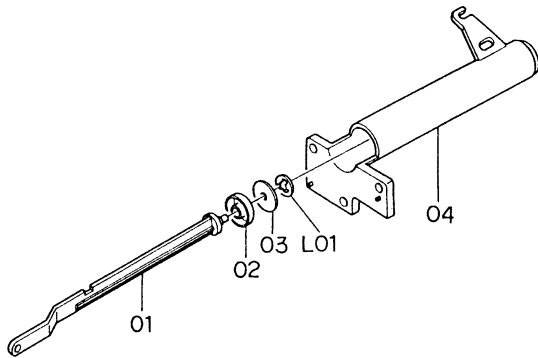

Fig. 8.27

8.28. Azimuth Motor Ass'y (H01)

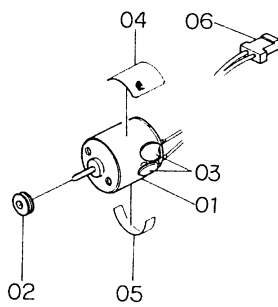

Fig. 8.28

8.29. P-8L Playback Head Ass'y (I01)

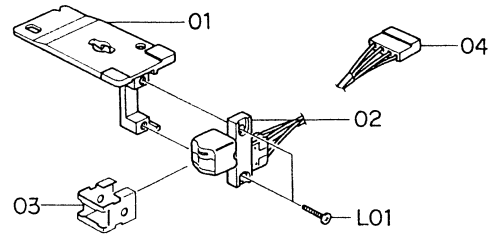

Fig. 8.29

8.30. R-8L Record Head Ass'y (I02)

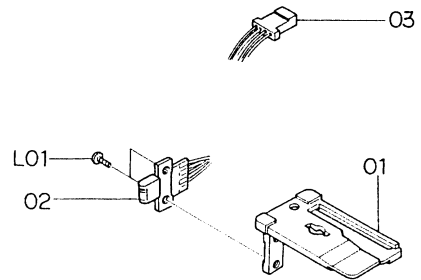

Fig. 8.30

Schematic Ref. No.	Part No.	Description	Q'ty
G07	CA08237A	Auto Shut-off Ass'y Serial No.: A11701001-	1
01	0C08047A	Shut-off Pulley A	1
02	0C08206B	Shut-off Pulley B	1
03	0C08088B	Shut-off Pulley Shaft	1
04	0C08207B	Shut-off Pulley Holder	1
05	BA04070A	Shut-off P.C.B. Ass'y	1
G08	CA08030A	Pneumatic Damper Ass'y Serial No.: A11701001-	1
01	0C08058C	Damper Piston	1
02	0C08102C	Damper Ring	1
03	0C08010C	Damper Plate	1
04	0C08059D	Sylinder	1
L01	0E00874A	Stopper Ring CS 2mm	1
H01	CA08149A	Azimuth Motor Ass'y Serial No.: A11701001-	1
01	0C08137A	Control Motor	1
02	0C08064A	Control Motor Pulley	1
03	0B09292A	Ceramic Capacitor 0.1 μ 50V Z	2
04	0M03985A	Motor Label 730	1
05	0M03988A	Motor Seal B	1
06	0B08708A	2P Connector	1
I01	CA08244A	P-8L Playback Head Ass'y Serial No.: A11701001-	1
01	0C08160F	Head Plate	1
02	GA02101A	P-8LZ Playback Head	1
03	0C08169D	Pad Lifter 54	1
04	0B08767A	4P-H Connector	1
L01	0E00886A	Screw M1.7x6.5 Philips Pan Head	2
I02	CA08238A	R-8L Record Head Ass'y Serial No.: A11701001-	1
01	0C08234B	Head Plate	1
02	GA02102A	R-8LZ Record Head	1
03	0B08768A	4P-H Connector	1
L01	0E00887A	Screw M1.7x4 Philips Pan Head	2

9. TIMING CHART AND FLOW CHART

9.1. Overall Timing Chart

Mode	Playback			Record					Cue		
	Stop	Play	Stop	Rec.	Rec./Play	Rec./Pause	Rec./Play	Stop	Stop	F.F. or Rew./Pause	Stop
Tape		370ms			370ms		140ms			160ms	
		300ms	70ms		300ms	70ms	70ms	70ms			60ms
Output		280ms			280ms		50ms			160ms	
Bias					240ms			330ms			

Fig. 9.1

9.2. Auto Calibration and RAMM Control

(1) Auto Calibration Timing Chart

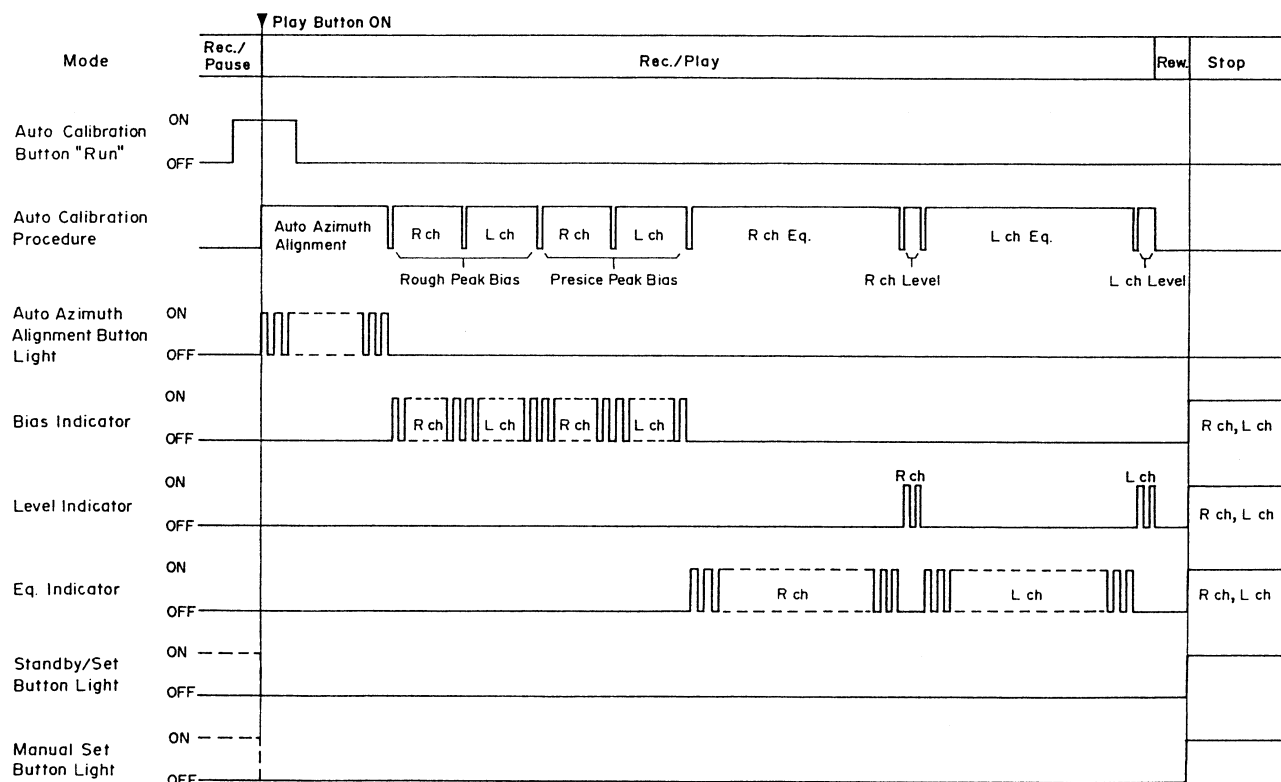

Fig. 9.2

(2) Auto Calibration Flow Chart

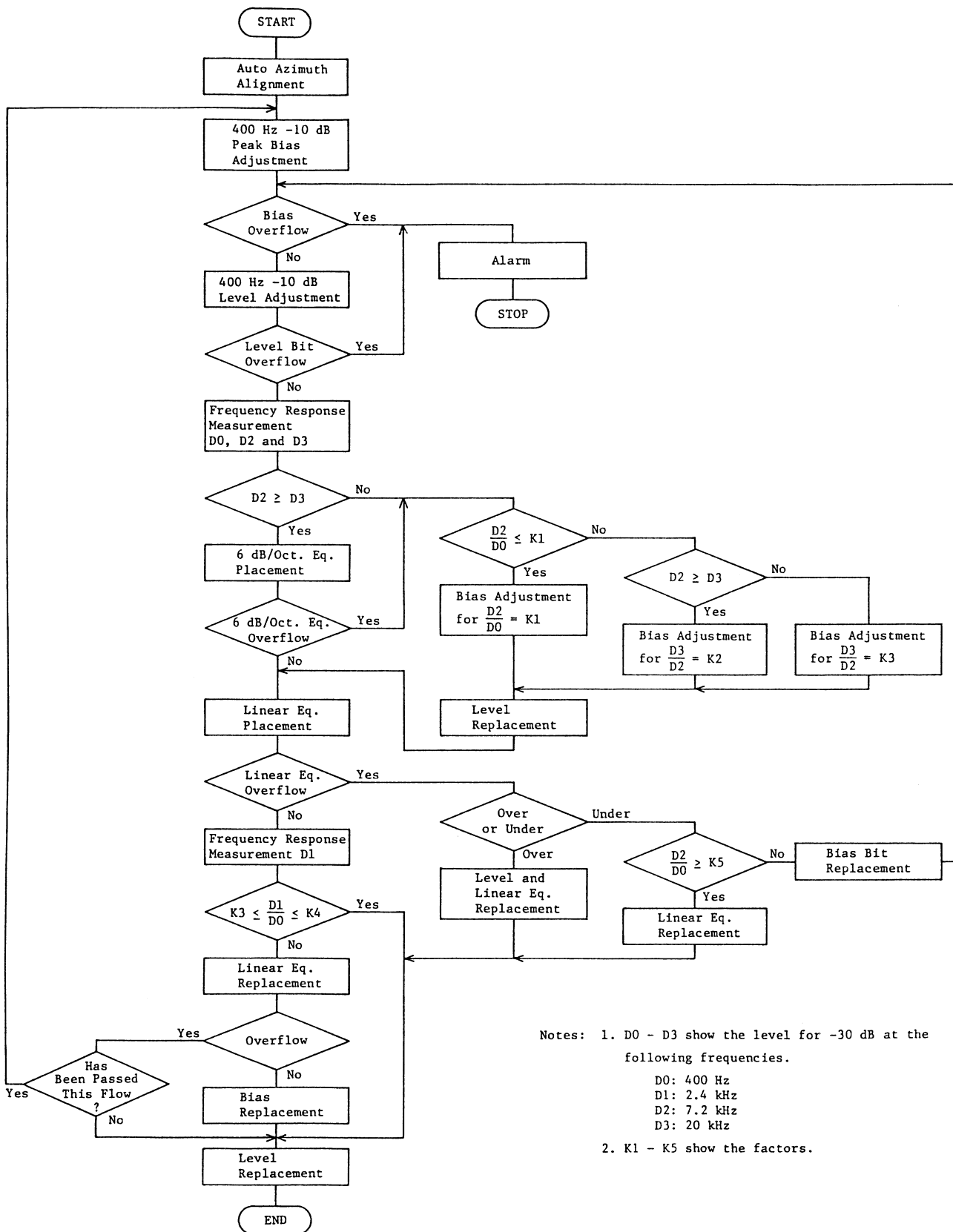

Fig. 9.3

(3) RAMM Coding Timing Chart

(a) Automatic Coding

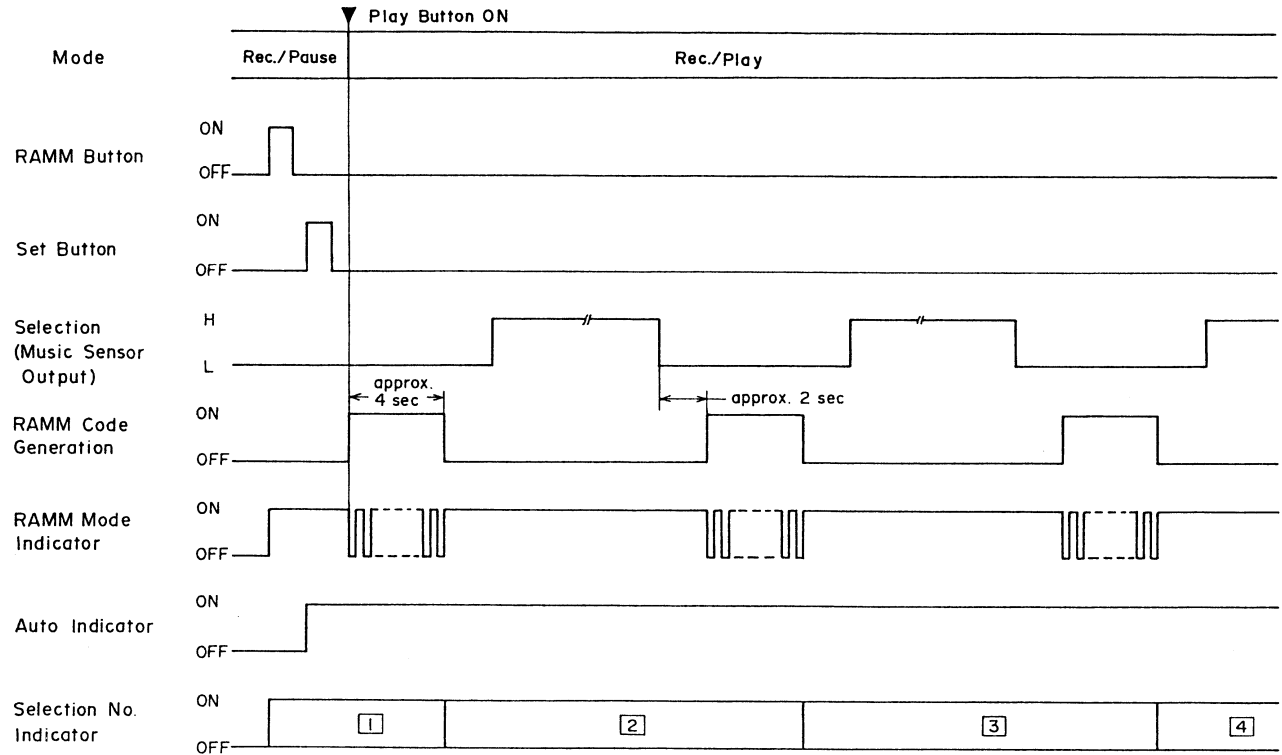

Fig. 9.4

(b) Manual Coding

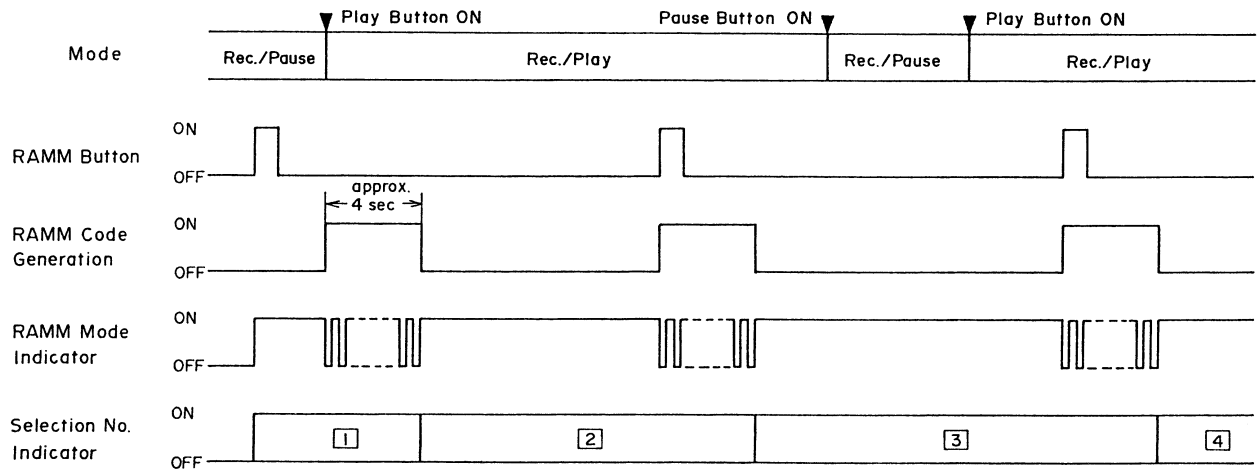

Fig. 9.5

(4) RAMM Code Tape Playback Flow Chart and Timing Chart

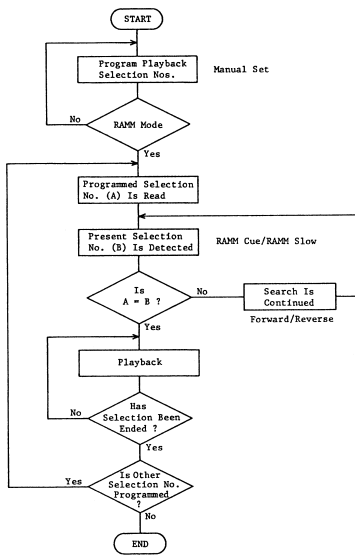
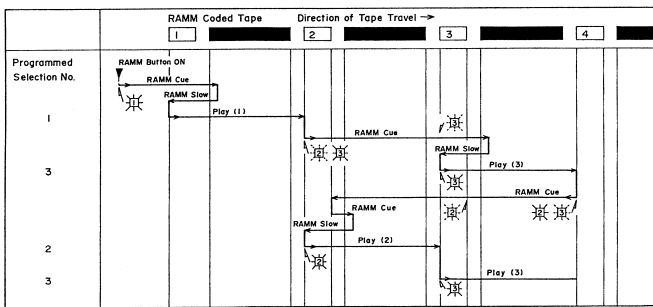

Fig. 9.6



Note: RAMM Code: Eq, Noise Reduction
Selection:

Fig. 9.7

10. EQ. AMP. FREQUENCY RESPONSE

10.1. Playback Frequency Response

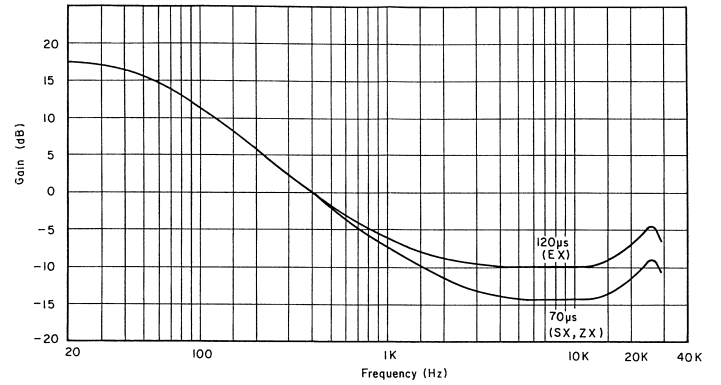

Fig. 10.1

10.2. Record Current Frequency Response

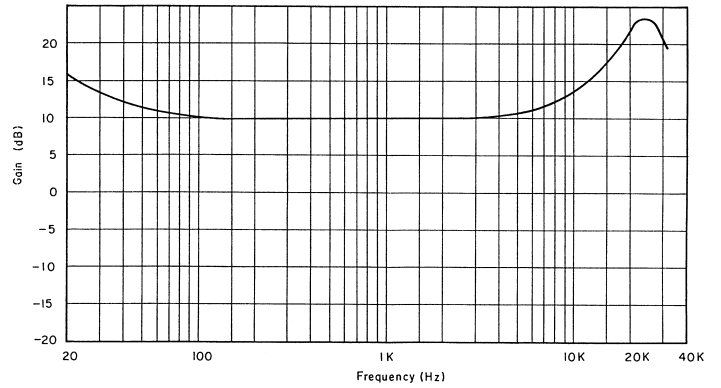

Fig. 10.2

Note: The curve shows the fixed record current frequency response before auto calibration is made in the N-1000ZXL without memory back-up batteries.

11. BLOCK DIAGRAMS

11.1. Amplifier and A.B.E.L. CPU Control

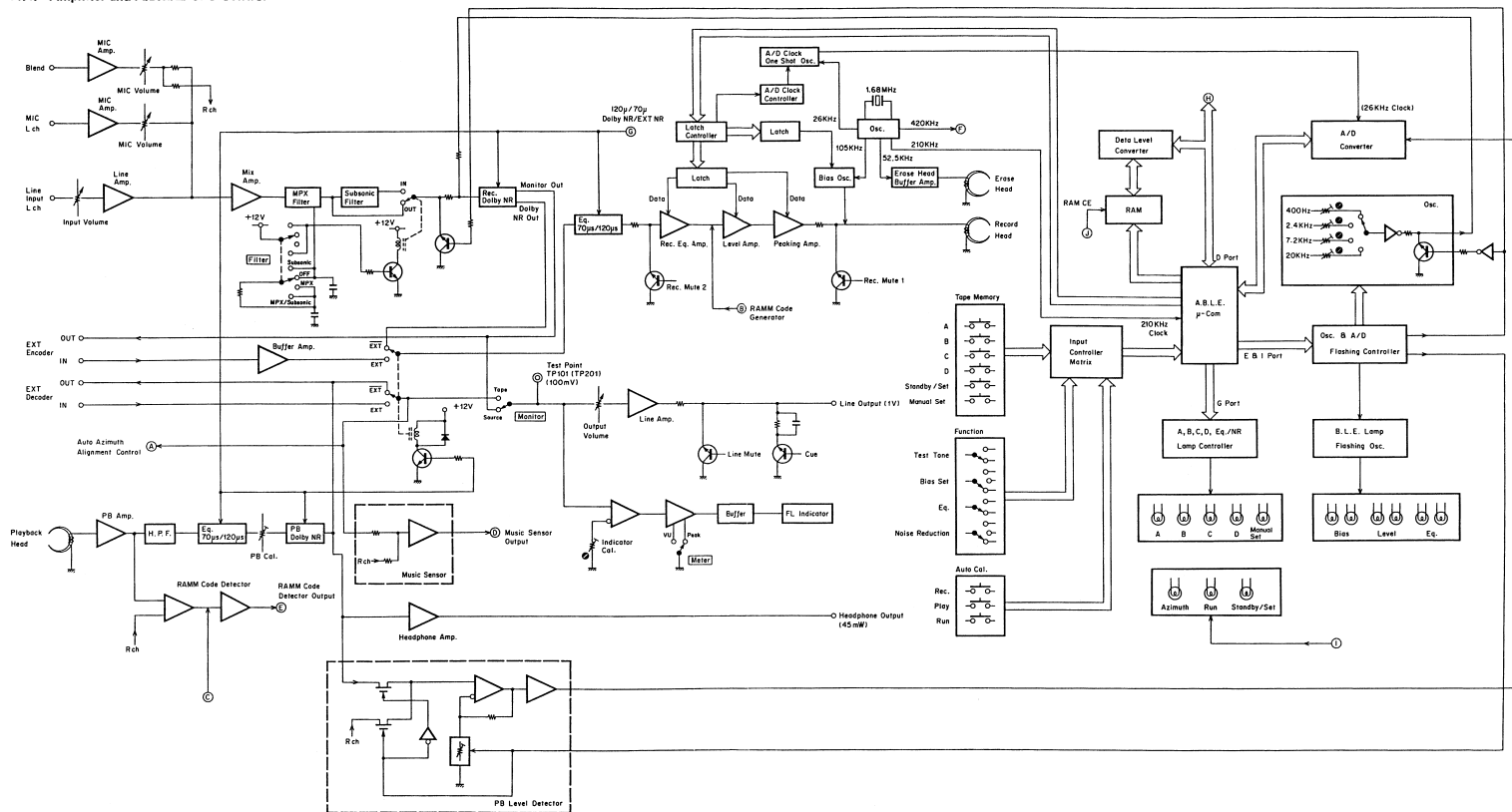

Fig. 11.1

11.2. Mechanism Control and RAMM Control

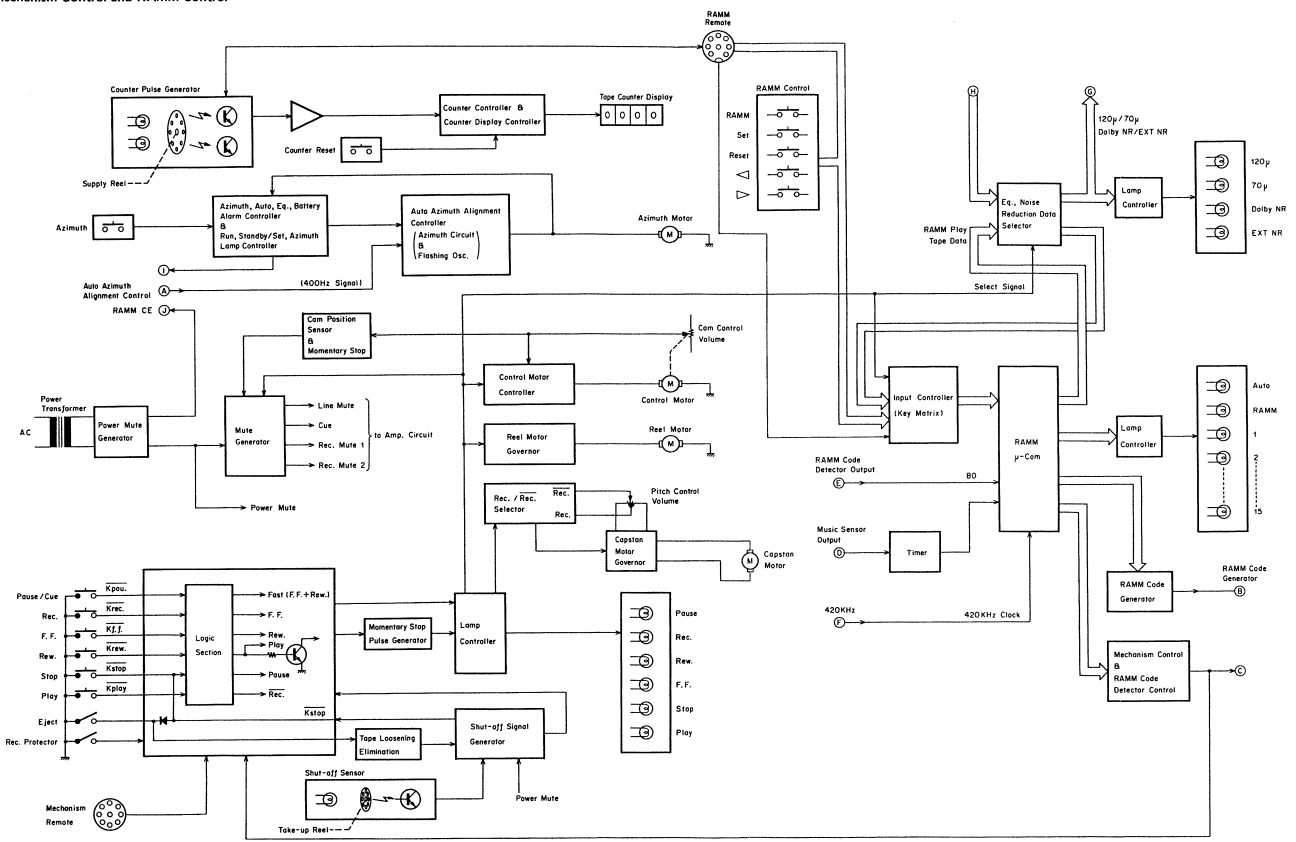

Fig. 11.2

12. WIRING DIAGRAM

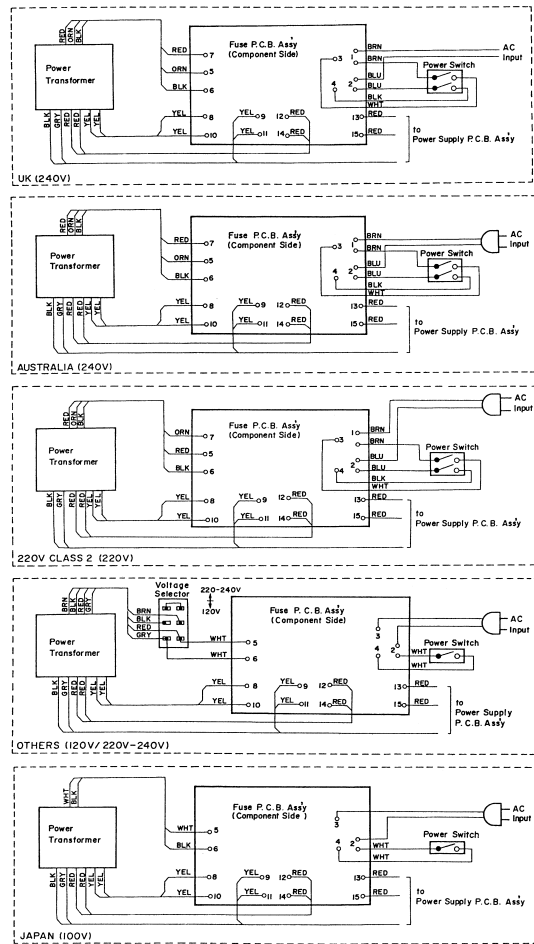

Fig. 12.1

Note: Table of wire colors
BLK - Black
BLU - Blue
GRN - Green
RED - Red
WHT - White
ORN - Orange
GRY - Gray
BRN - Brown
VEL - Yellow
VIO - Violet

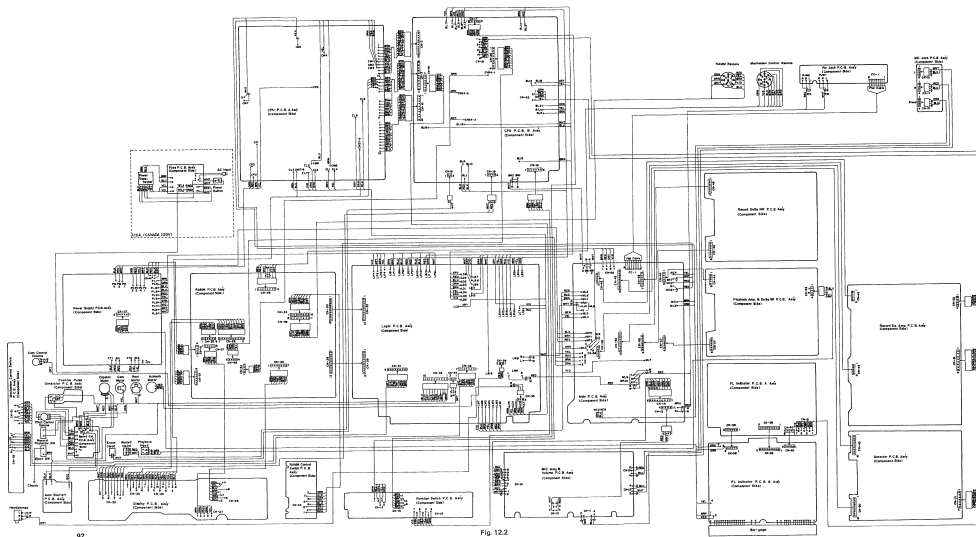
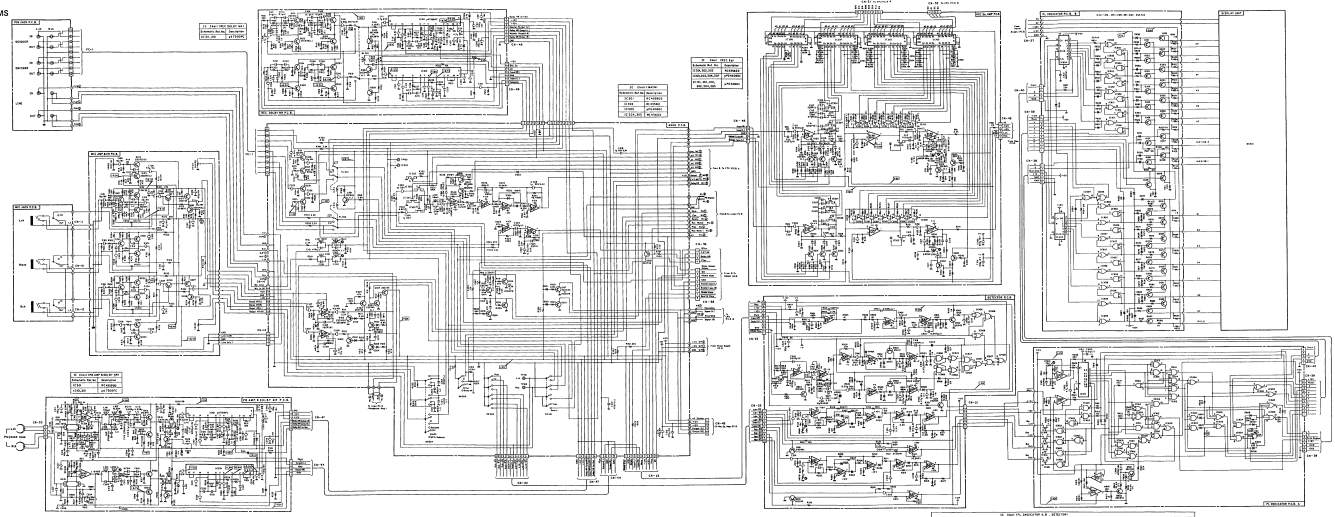

Fig. 12.2

13. SCHEMATIC DIAGRAMS
13.1. Amplifier Section



Note:
1. Diode is 15523, 15593, or 151550 unless otherwise specified.
2. Resistor and capacitor marked with * show typical value.

Fig. 13.1

Part No.	Quantity	Part No.	Quantity	Part No.	Quantity	Part No.	Quantity	Part No.	Quantity
15523	1	15593	1	151550	1	15523	1	15593	1
151550	1	15523	1	15593	1	151550	1	15523	1
15593	1	151550	1	15523	1	15593	1	151550	1

13.2. CPU Section

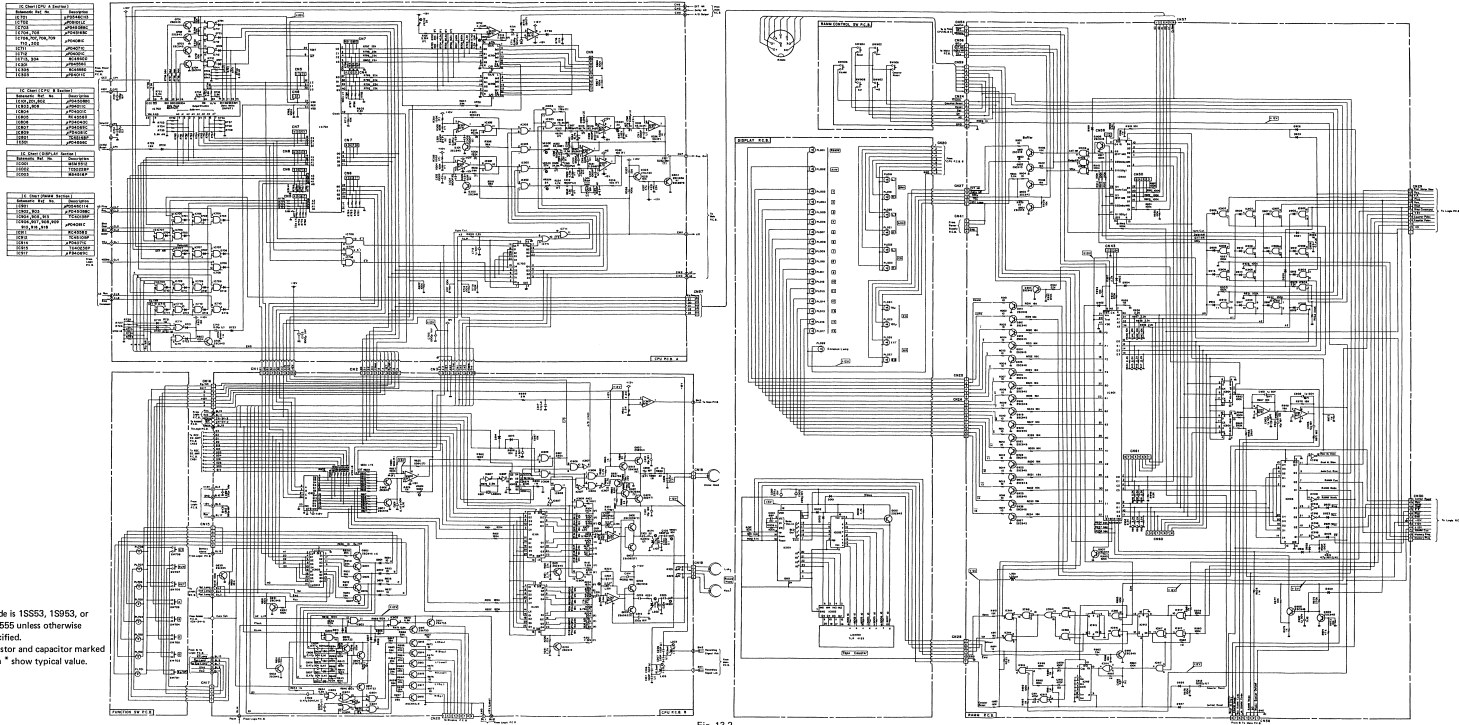

Notes:
 1. Diode is 1S853, 1S953, or 1S1555 unless otherwise specified.
 2. Resistor and capacitor marked with * show typical value.

Fig. 13.2

13.3. Mechanism Control Section

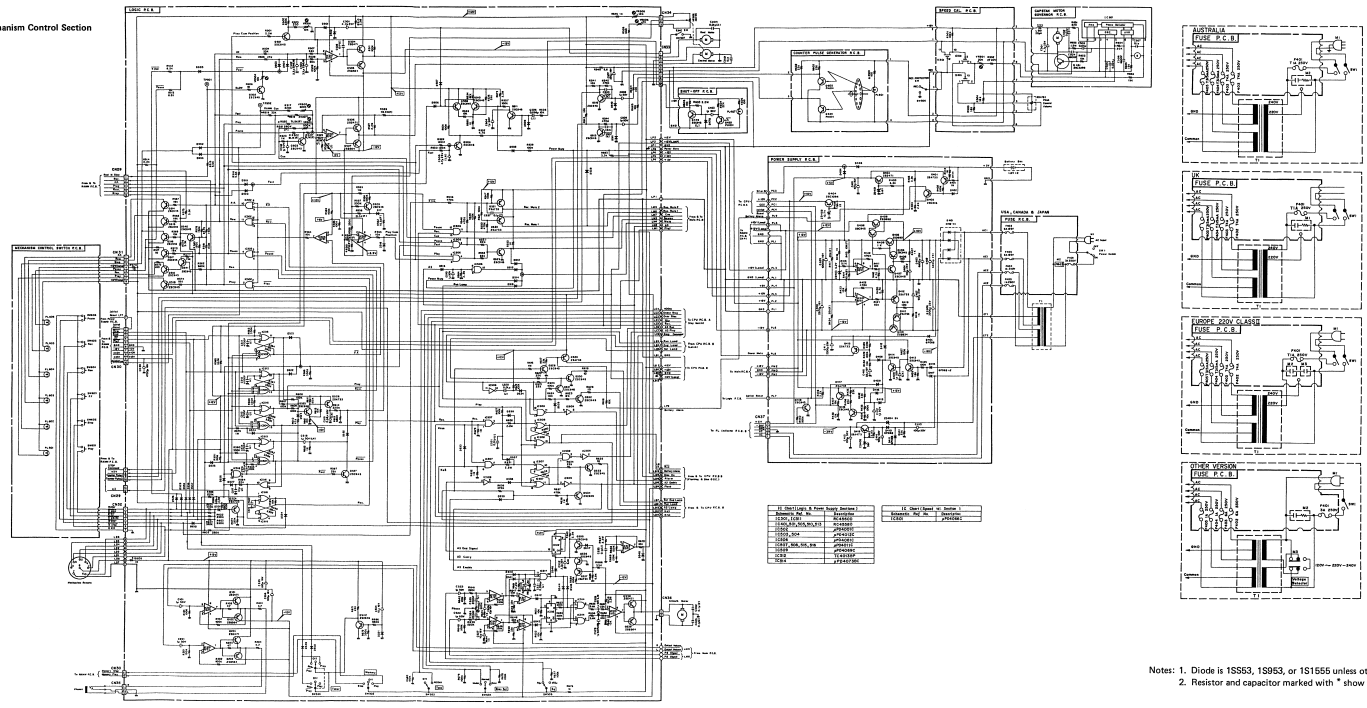

Fig. 13.3

Notes: 1. Diode is 1S553, 1S953, or 1S1555 unless otherwise specified.
 2. Resistor and capacitor marked with * show typical value.

13.4. IC Block Diagrams

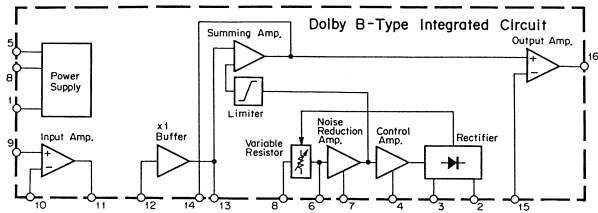

Fig. 13.4 Dolby NR IC μA7300PC

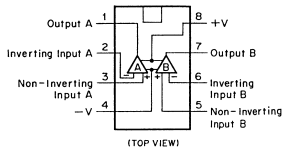

Fig. 13.5 OP Amp. IC 4558, 4559, 4560, 4556

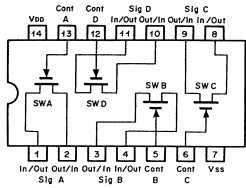

Fig. 13.6 Bilateral Switch C-MOS IC μPD4066C

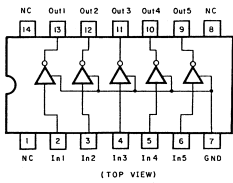

Fig. 13.7 Transistor Array M54516P

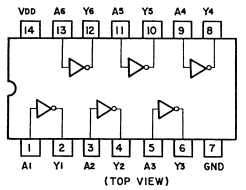

Fig. 13.8 Inverter C-MOS IC μPD4049C

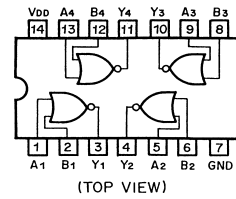

Fig. 13.9 NOR Gate C-MOS IC μPD4001C

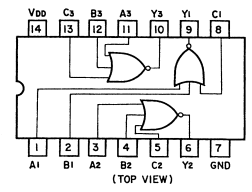

Fig. 13.13 NOR Gate C-MOS IC μPD4025C

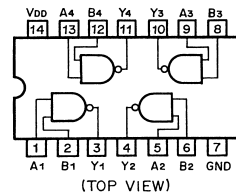

Fig. 13.10 NAND Gate C-MOS IC μPD4011C

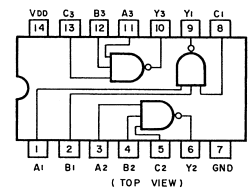

Fig. 13.14 NAND Gate C-MOS IC TC4023BP

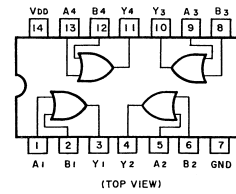

Fig. 13.11 OR Gate C-MOS IC μPD4071C

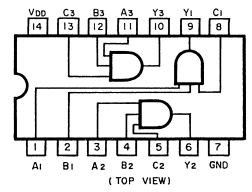

Fig. 13.15 AND Gate C-MOS IC μPD4073BC (TC4073BP)

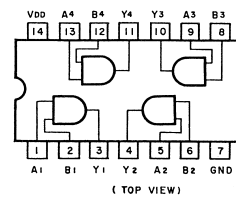

Fig. 13.12 AND Gate C-MOS IC μPD4081C

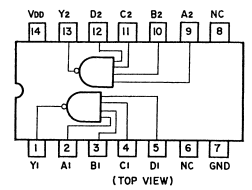

Fig. 13.16 NAND Gate C-MOS IC μPD4012C

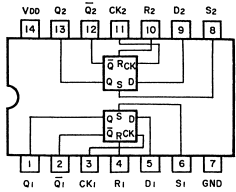

Fig. 13.17 D-Type Flip-Flop C-MOS IC TC4013BP

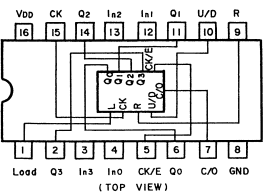

Fig. 13.18 BCD Up/Down Counter C-MOS IC TC4510BP

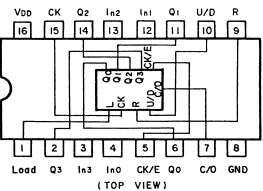

Fig. 13.19 Binary Up/Down Counter C-MOS IC TC4516BP

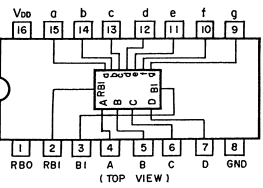

Fig. 13.20 BCD to 7-Segment Decoder/Driver C-MOS IC TC5022BP

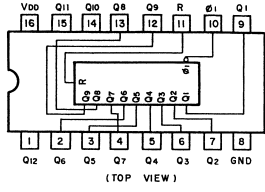

Fig. 13.21 12-Stage Binary Counter C-MOS IC TC4040BP

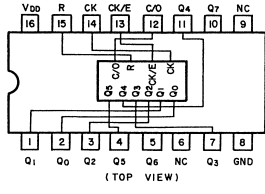

Fig. 13.22 Octal Counter/Driver C-MOS IC TC4022BP

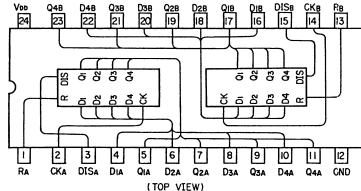

Fig. 13.23 4-Bit Latch C-MOS IC TC4508BP (μPD4508BC)

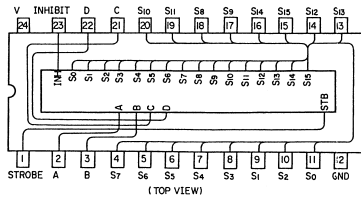

Fig. 13.24 4-to-16 Line Decoder C-MOS IC TC4514BP

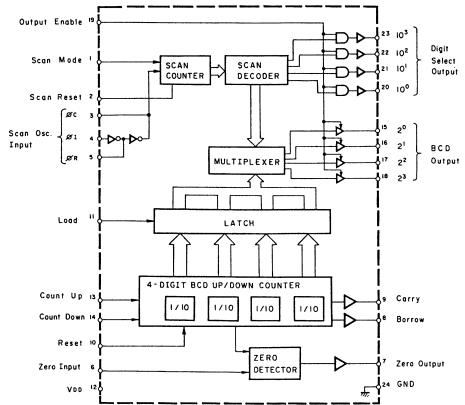

Fig. 13.25 4-Digit BCD Up/Down Counter C-MOS IC MSM5512RS

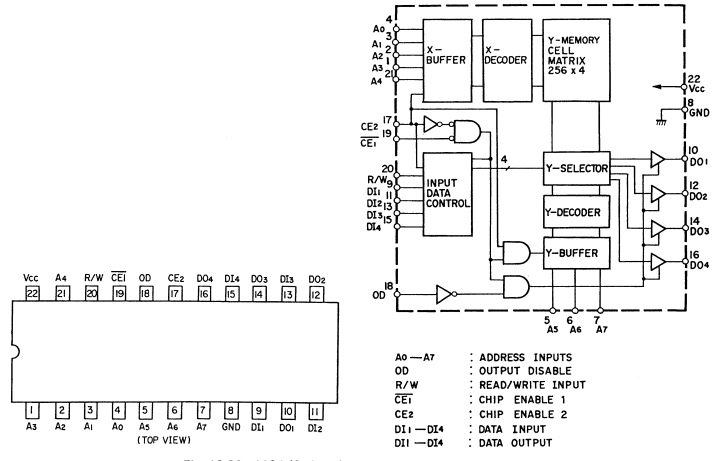
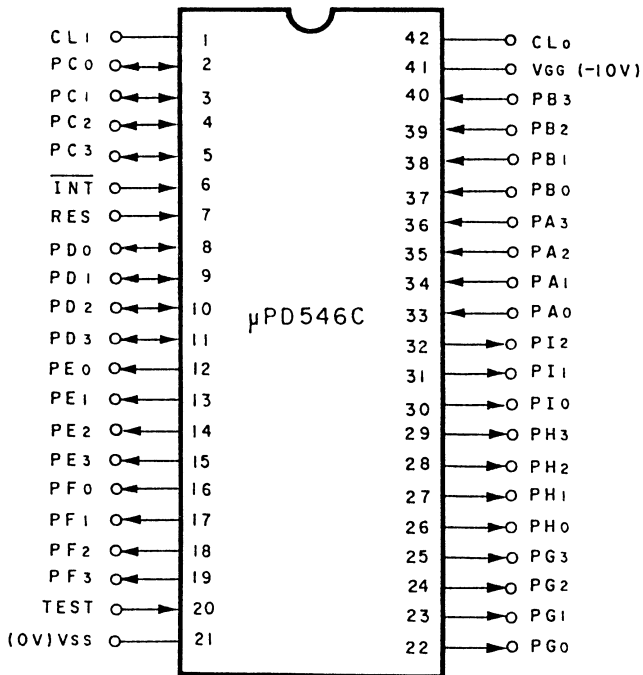
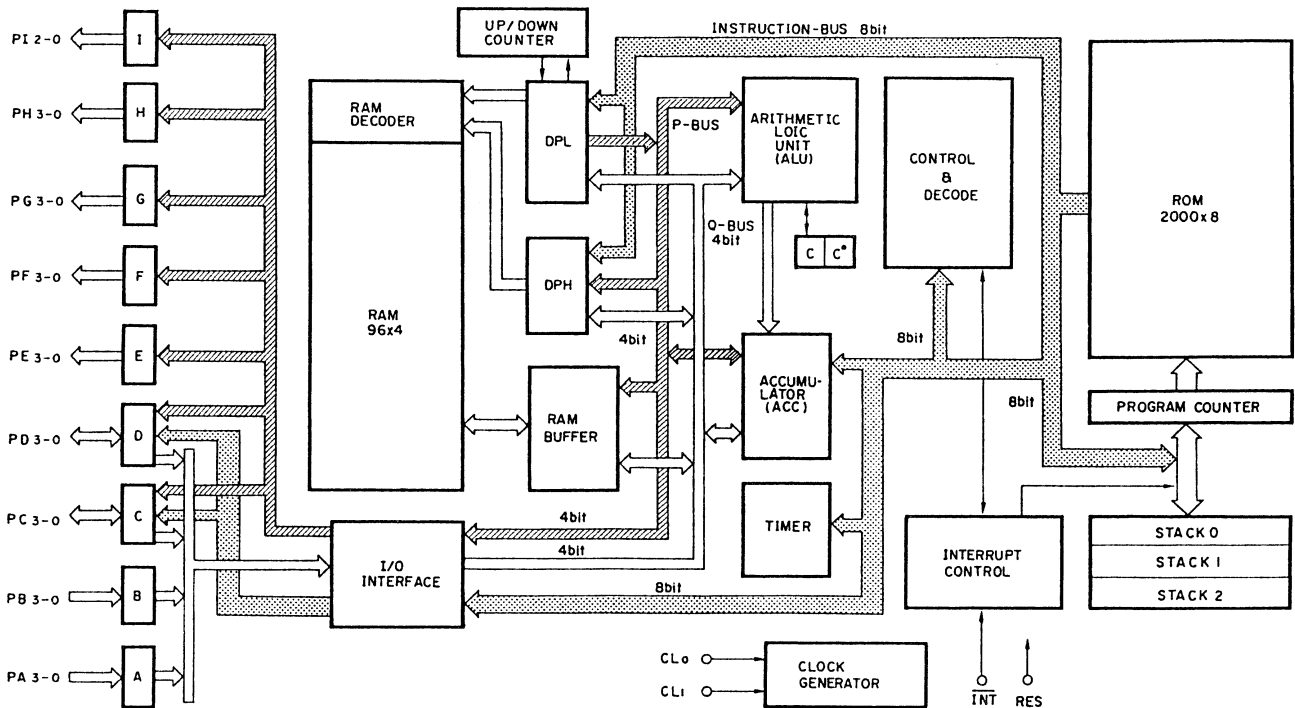

Fig. 13.26 1024 (256 x 4) Bit Static RAM IC μPD5101LC



- CL_{0,1} : Crystal, inductor, or resistor input for internal oscillator
- $\overline{\text{INT}}$: Interrupt
- RES : Reset
- PA₃₋₀ : Input port A₃₋₀
- PB₃₋₀ : Input port B₃₋₀
- PC₃₋₀ : Bidirectional port C₃₋₀
- PD₃₋₀ : Bidirectional port D₃₋₀
- PE₃₋₀ : Output port E₃₋₀
- PF₃₋₀ : Output port F₃₋₀
- PG₃₋₀ : Output port G₃₋₀
- PH₃₋₀ : Output port H₃₋₀
- PI₂₋₀ : Output port I₂₋₀
- TEST : Test

(TOP VIEW)



DP : DATA POINTER
 C : CARRY Flip-Flop
 C* : CARRY STRAGE Flip-Flop

Fig. 13.27 4-Bit Micro-processor μPD546C-113/114

14. REMOTE CONTROLLER RM-300

14.1. Schematic Diagram

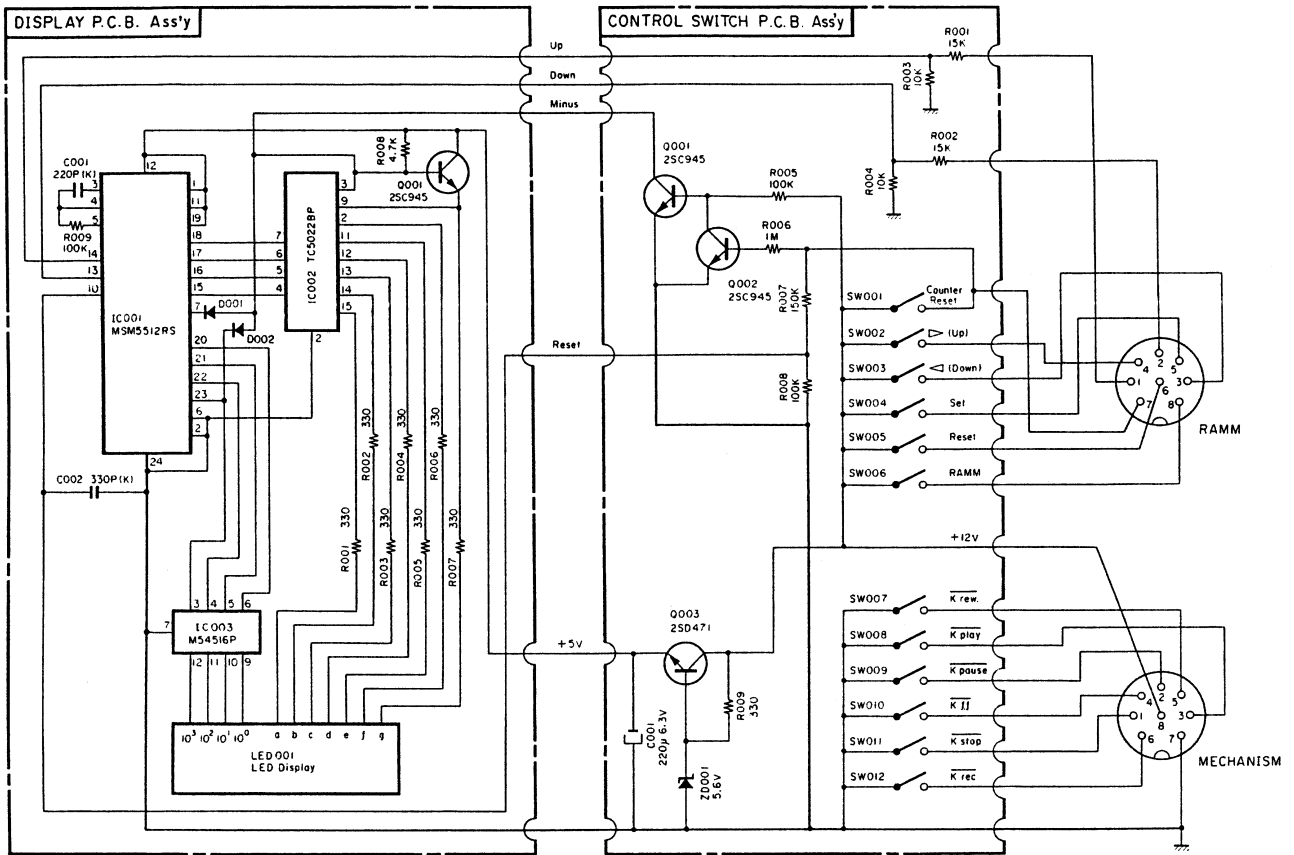

Fig. 14.1 Note: Diode is 1SS53 unless otherwise specified.

14.2. Mounting Diagrams and Parts List

Note: Mounting diagram shows a dip side view of the printed circuit board.

(1) Control Switch P.C.B. Ass'y

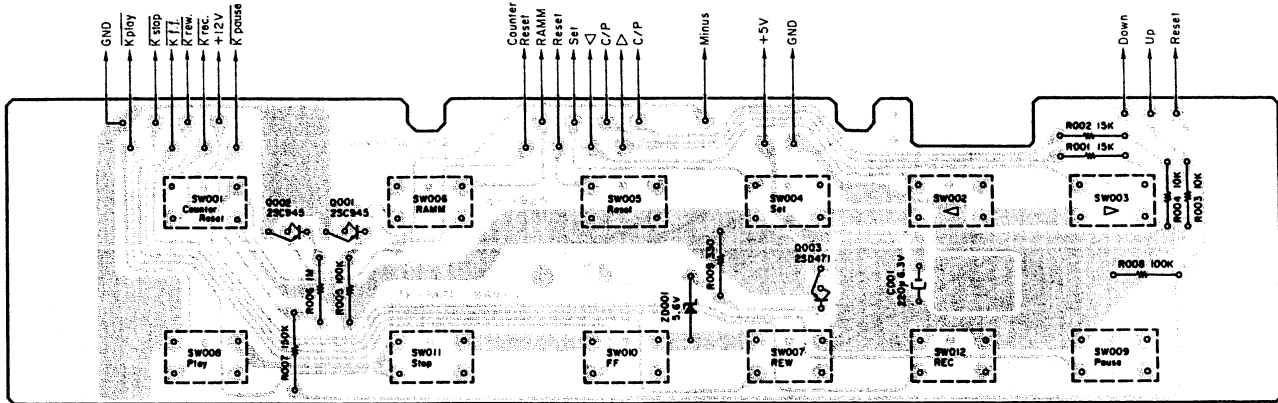

Fig. 14.2

(2) Display P.C.B. Ass'y

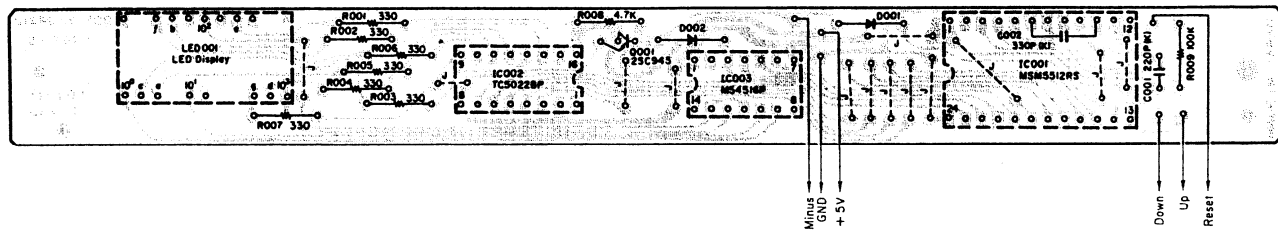

Fig. 14.3

Note: Diode is 1SS53 unless otherwise specified.

Schematic Ref. No.	Part No.	Description	Schematic Ref. No.	Part No.	Description
	BA04307A	Control Switch P.C.B. Ass'y		BA04306A	Display P.C.B. Ass'y
Q001,002	0B07925A	Control Switch P.C.B.	IC001	0B07924A	Display P.C.B.
Q003	0B06100A	Transistor 2SC945 (A)	IC002	0B06259A	IC MSM5512RS
ZD001	0B06066A	Transistor 2SD471	IC003	0B06211A	IC TC5022BP
R001,002	0B01683A	Carbon Resistor 15K ERD-25T J	Q001	0B06258A	IC M45516P
R003,004	0B01888A	Carbon Resistor 10K ERD-25T J	Q001,002	0B06100A	Transistor 2SC945 (A)
R005	0B01889A	Carbon Resistor 100K ERD-25T J	D001,002	0B06181A	Silicon Diode 1SS53
R006	0B05776A	Carbon Resistor 1M ERD-25T J	R001-007	0B05577A	Carbon Resistor 330 ERD-25T J (7 pcs.)
R007,008	0B05626A	Carbon Resistor 150K ERD-25T J	R008	0B01846A	Carbon Resistor 4.7K ERD-25T J
R009	0B05577A	Carbon Resistor 330 ERD-25T J	R009	0B01889A	Carbon Resistor 100K ERD-25T J
C001	0B09151A	Electrolytic Capacitor 220µ 6.3V	C001	0B09283A	Ceramic Capacitor 220P 50V K
SW001-012	0B07354A	Push Switch KHG10901 (12 pcs.)	C002	0B09285A	Ceramic Capacitor 330P 50V K
			LED001	0B06289A	LED Display Unit (1 pce.)
				QJ04237A	Counter Himelton

14.3. Mechanism Ass'y and Parts List

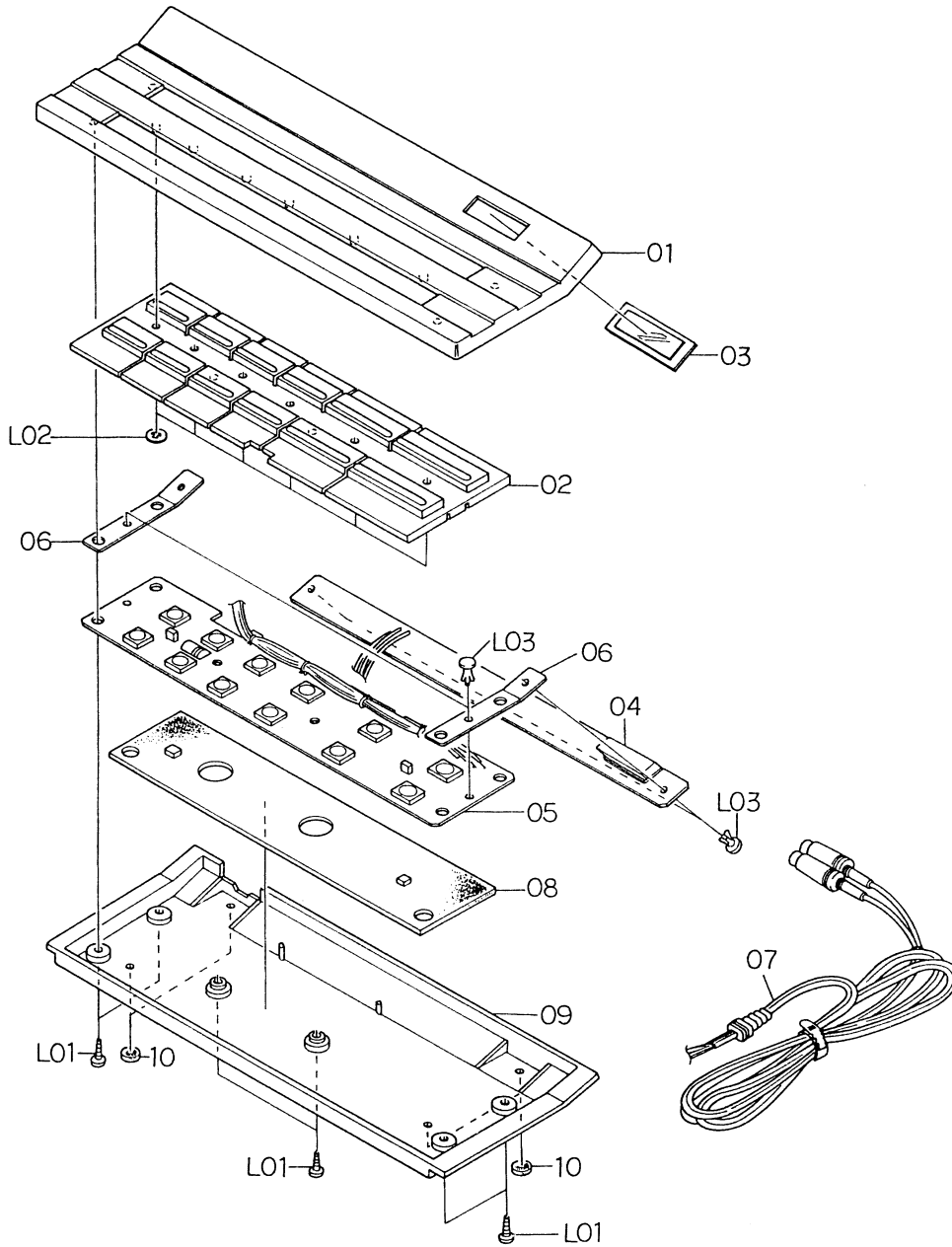

Fig. 14.4

Schematic Ref. No.	Part No.	Description	Q'ty	Schematic Ref. No.	Part No.	Description	Q'ty
		RM-300 Mechanism Ass'y			0B08831A	Cord Stopper	(1)
01	0H03917A	Top Case	1		0B08865A	8P DIN Plug (RAMM)	(1)
02	0H03918A	Switch Knob	1	08	0B08866A	8P DIN Plug (Mechanism)	(1)
03	0H03922A	Counter Lens	1	09	0J04287A	Bottom Case Rubber	1
04	BA04306A	Display P.C.B. Ass'y	1	10	0H03918A	Bottom Case	1
05	BA04307A	Control Switch P.C.B. Ass'y	1	L01	0H03920A	Leg	4
06	0J04266A	P.C.B. Holder	2		0E00938A	BT Screw M3x8 Philips Binding Head (Black Chromate)	6
07	BA04309A	Remote Cord Ass'y	1	L02	0E00252A	Stopper Ring CS 3mm	6
	0B08827A	Cord Bushing	(1)	L03	0B08539A	Plastic Rivet	4
	0B08828A	8Px2 Cord	(1)				

15. SPECIFICATIONS

Power Source	100, 120, 120/220-240, 220 or 240 V AC ; 50/60 Hz (According to country of sale)
Power Consumption	65 W max.
Tape Speed	1-7/8 ips (4.75 cm/sec.)
Wow and Flutter	Less than 0.04% Wrms Less than 0.08% Wpeak
Frequency Response (w. auto calibration)	20–20,000 Hz \pm 0.75 dB (18–25,000 Hz \pm 3 dB) Nakamichi EX, EXII, SX, ZX tape Recording level –20 dB
Signal to Noise Ratio	Better than 66 dB (3% THD) Better than 60 dB (0 dB) (IHF-A, Wrms, 400 Hz, w. Dolby NR, ZX tape, 70 μ sec)
Total Harmonic Distortion	Less than 0.8% (ZX tape) Less than 1.0% (SX, EXII tape) (400 Hz, 0 dB)
Erasure	Better than 60 dB (100 Hz)
Separation	Better than 37 dB (1 kHz, 0 dB)
Crosstalk	Better than 60 dB (1 kHz, 0 dB)
Bias Frequency	105 kHz
Input (Line)	50 mV 50 k ohms
(Microphone)	0.2 mV, 10 k ohms
(Noise Reduction)	100 mV, 50 k ohms
Output (Line)	1 V (400 Hz, 0 dB, output control at max.)
(Headphone)	45 mW (400 Hz, 0 dB, output control at max.)
(Noise Reduction)	100 mV, 2.2 k ohms
Dimensions	527 (W) x 258 (H) x 322 (D) millimeters 20-3/4 (W) x 10-5/32 (H) x 12-43/64 (D) inches
Approximate Weight	19 kg 41 lb. 14 oz

- Specifications and appearance design are subject to change for further improvement without notice.
- Dolby NR under license from Dolby Laboratories.
- The word “DOLBY” and the Double-D-Symbol are trademarks of Dolby Laboratories.

1000ZXL