

119



Service Manual

430

Nakamichi 430 FM Tuner

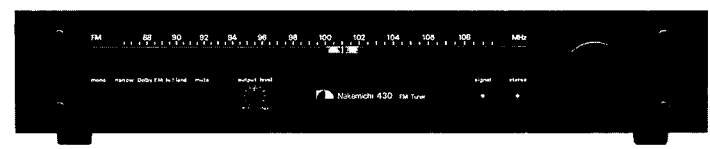

CONTENTS

1.	General	2
2.	Principle of Operation	3
2.	1. Tuner Section	3
	2.1.1. FM MPX Stereo Broadcasting Operation	3
	2.1.2. Operation of N-430 Tuner Section	4
2.	2. Indicator Logic	5
2.	3. Mute Signal	7
3.	Removal Procedures	8
3.	1. Top Cover, Front Panel Ass'y and Bottom Cover	8
3.	2. Front Chassis Ass'y	8
3.	3. P.C.B. Assemblies	8
3.	4. Power Supply Ass'y and Rear Panel Ass'y	8
4.	Electrical Adjustments and measurements	9
5.	Dial Threading	13
5.	1. How to Prepare the Dial Thread	13
5.	2. How to Fit Front-end Pulley 430	13
5.	3. How to Set Dial Threading	13
6.	Mounting Diagrams and Parts List	14
6.	1. Main P.C.B. Ass'y	14
6.	2. Indicator H.P.F. P.C.B. Ass'y	15
6.	3. MPX P.C.B. Ass'y	15
6.	4. Dolby NR P.C.B. Ass'y (Option)	16
6.	5. Switch P.C.B. Ass'y	17
6.	6. Lamp P.C.B. Ass'y	17
6.	7. Stereo Lamp P.C.B. Ass'y	17
6.	8. Power Supply P.C.B. Ass'y	18
7.	Mechanism Ass'y and Parts List	19
7.	1. Synthesis Mechanism Ass'y (K01)	19
7.	2. Tuner Mechanism Ass'y (K02)	20
7.	3. Front Panel Ass'y (K03)	21
7.	4. Power Supply Ass'y (A01)	22
7.	5. Main Chassis Ass'y (A02)	23
7.	6. Front Chassis Ass'y (A03)	24
7.	7. Rear Panel Ass'y (A04)	25
8.	Performance Data	26
9.	Block Diagram	27
10.	Wiring Diagram	28
11.	Schematic Diagram	29
12.	Specifications	30

1. GENERAL

Nakamichi 430 control functions are shown below:

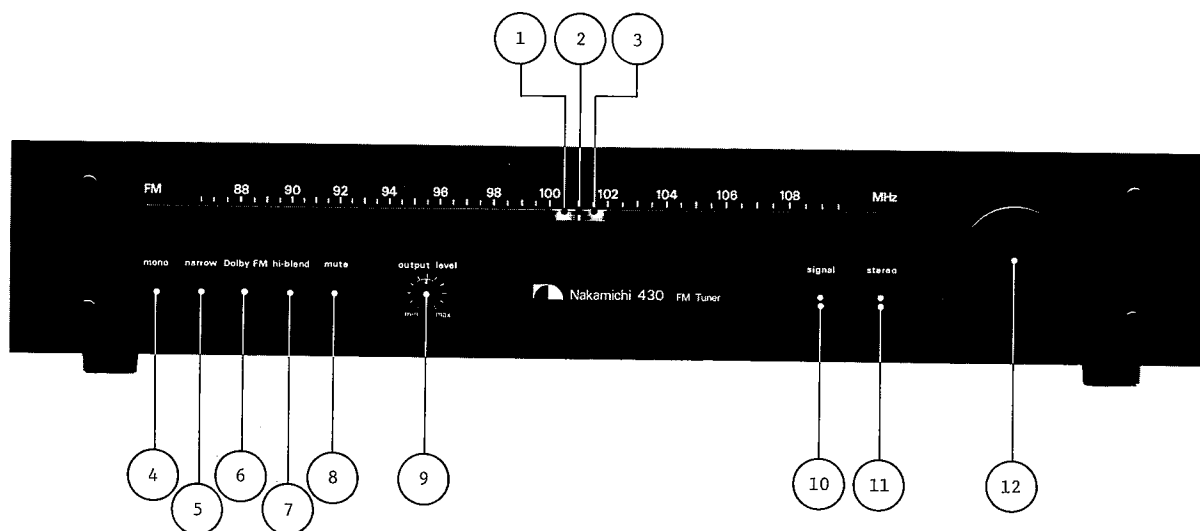

Fig. 1.1 Front View

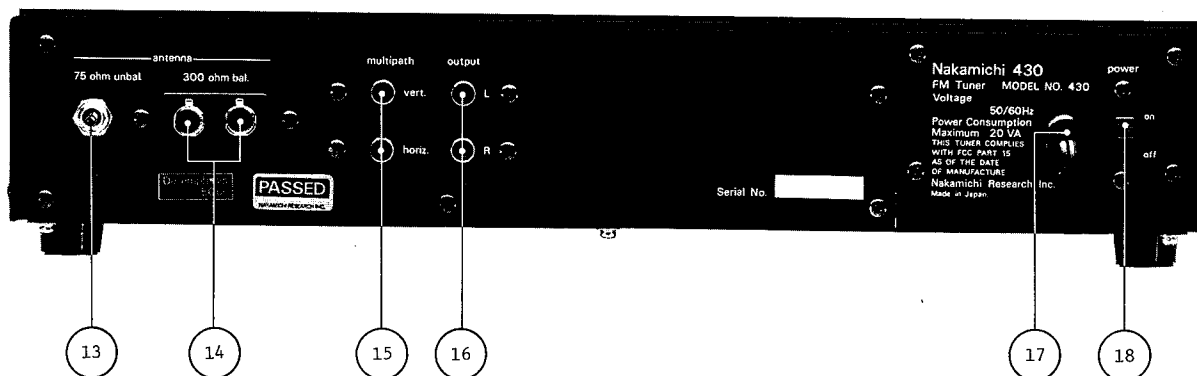

Fig. 1.2 Rear View

- | | |
|-------------------------|----------------------------------|
| 1. Tuning Indicator | 10. Signal Indicator |
| 2. Dial Pointer | 11. Stereo Indicator |
| 3. Tuning Indicator | 12. Tuning Dial |
| 4. Mono Switch | 13. 75-ohm FM Antenna Connector |
| 5. Narrow Switch | 14. 300-ohm FM Antenna Terminals |
| 6. Dolby FM Switch | 15. Multipath Output Jacks |
| 7. Hi-Blend Switch | 16. Output Jacks |
| 8. Muting Switch | 17. AC Line Cord |
| 9. Output Level Control | 18. Power Switch |

Switching FM De-emphasis

The time constants of pre-emphasis in FM broadcasting over the world are classified either to 50 or 75 μ s. 430 can select both time constants by switching the internal switch.

For this switching operation, remove the bottom cover of 430 (by removing six screws). The front and rear sides of the switch select either 50 or 75 μ s. Further, switching can be performed by inserting a small screwdriver through a slit provided on the bottom cover without removing the cover.

The time constant of 75 μ s is employed in the U.S.A. and some other countries, and 50 μ s in Europe and other countries including Japan.

Caution

If the Dolby FM switch is depressed without the Dolby NR circuit, no output is available. (Dolby NR P.C.B. Ass'y is an optional accessory to be ordered separately.)

2. PRINCIPLE OF OPERATION

2.1 Tuner Section

2.1.1. FM MPX Stereo Broadcasting Operation

As is generally known, the amplitude of the carrier wave is modulated in AM broadcasting whereas the carrier frequency is modulated in FM broadcasting. Fig. 2.1 illustrates these conditions.

FM transmitters and receivers, although considerably more complicated than those for AM broadcasting, permit radio reception with very high fidelity and any difference in technical skill will be noticeably manifested in the performance of the equipment. Compared to AM broadcasting, FM broadcasting has many advantages, such as better frequency response, higher S/N ratio, less interference, less distortion, etc. However, its greatest advantage is the capability for compatible stereo broadcasting. This is achieved by employing a composite signal, as shown in "4" of Fig. 2.2, instead of the audio signal shown in Fig. 2.1.

Since the composite signals transmitted in ordinary broadcasting have an extremely complex waveform, it is hard to recognize them, even when observed with an oscilloscope. Figure 2.2 illustrates an L channel signal of 1900 Hz with no R channel signal.

As shown in "1" of Fig. 2.2, this is a stereo signal modulated so as to swing at 38 kHz between the L channel signal and R channel signal.

Therefore, this signal can be separated into L ch/R ch, by a synchronizing signal with the 38 kHz of the stereo signal and a circuit which is conducting at the positive peak and negative peak of this synchronizing signals; the L ch/R ch signals will come out separately.

But, as is shown by the signal waveform "1" in Fig. 2.2, since the phase at 38 kHz is reversed between the positive and negative half-cycles of the L ch signal, even with the

separation described above, it is not possible to distinguish L ch from R ch.

Under these conditions, it is possible that the L ch/R ch is reversed each time the power switch is turned ON/OFF. Here lies the importance of the pilot signal.

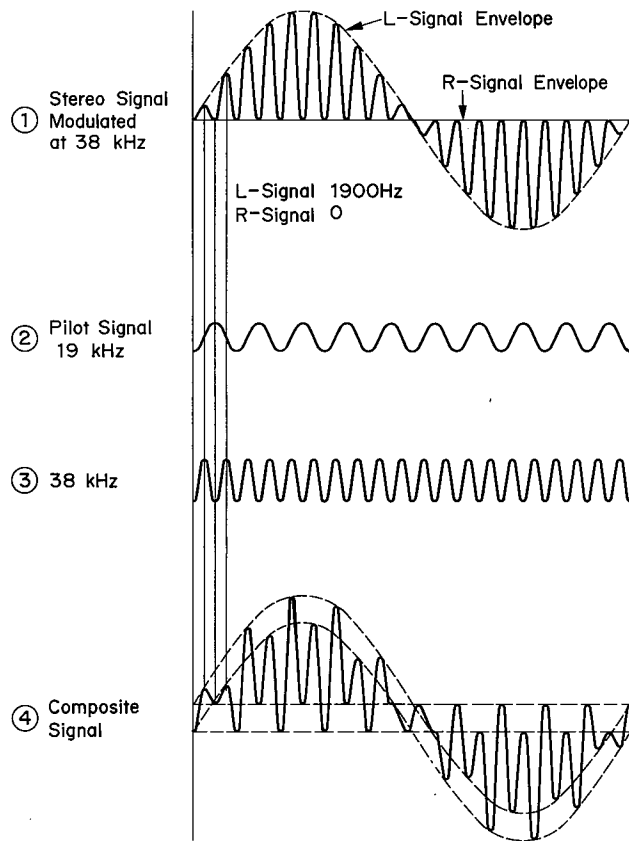

Fig. 2.2 MPX Stereo Signal

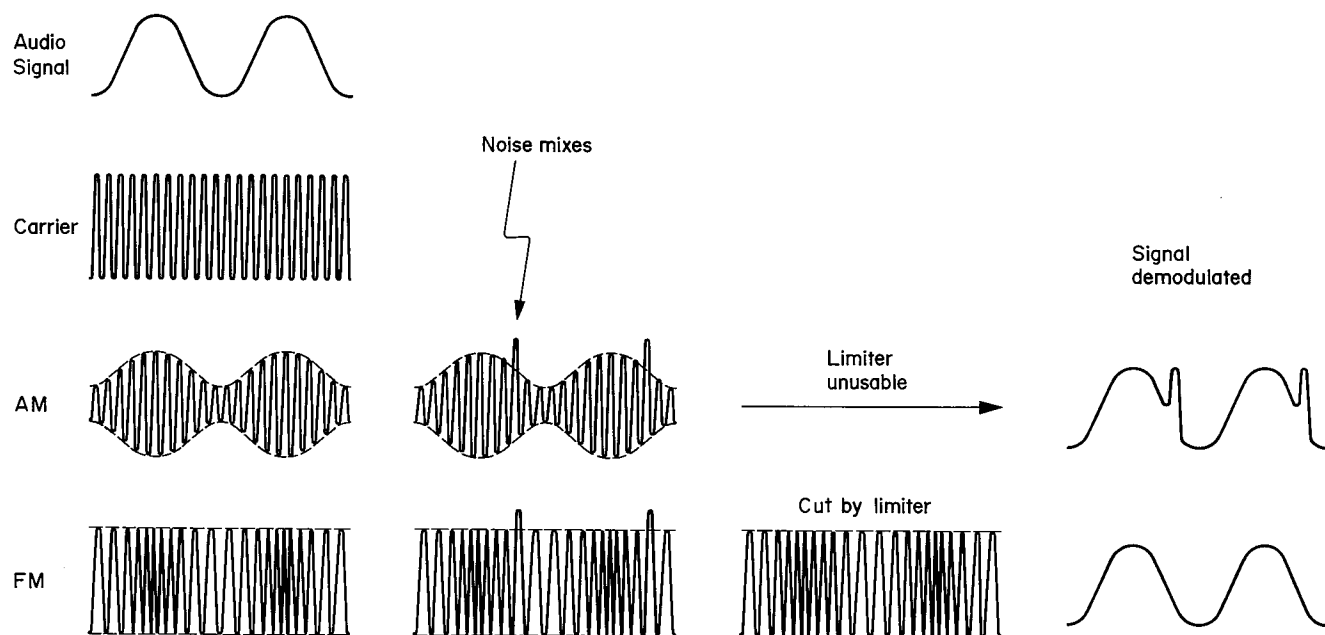

Fig. 2.1 AM and FM

That is, when making the 38 KHz signal ("3" in Fig. 2.2) by doubling the 19 KHz pilot signal, if the positive and negative peaks of the 19 KHz wave are synchronized with a negative peak at the 38 KHz, L channel can be taken out at the positive peak of the 38 KHz signal and the R channel at the negative peak. Thus, MPX stereo signals are broadcast in a waveform such as composite signal "4", obtained by combining the pilot signal "2" with the stereo signal "1" in Fig. 2.2.

In order to divide the FM signal into the left and right channels, the MPX stage of an FM tuner must synchronize the multiplex signal with the 19 KHz pilot signal. If this synchronization is not properly performed, stereo separation will be poor.

2.1.2. Operation of N-430 Tuner Section

Fig. 2.3 shows a block diagram of the N-430 tuner section.

The input from an antenna which first enters the radio frequency unit (front-end), is amplified in a tuning circuit, and mixed with a local oscillator frequency, and an inter frequency (IF 10.7 MHz) is produced. Since the radio frequency is high and it is impossible to obtain stable amplification and sufficient separation, it is converted to an easy-to-handle 10.7 MHz. Conversion to IF is made to improve these characteristics.

Frequency conversion makes use of the fact that when two different frequencies are mixed and detected, a frequency component equal to the difference between the two frequencies is generated.

Since radio frequencies vary according to the choice of the station, the tuning circuit must be adjustable. However, the use of an inter frequency fixed at 10.7 MHz makes it possible to achieve an optimum tuning characteristics with a multi-stage tuning circuit (4-stages in the N-430) and sharp separation with a ceramic filter.

Also, the function of a limiter to remove extraneous noise, as usual in an inter frequency unit, requires a sufficiently high-degree of amplification (130 dB or more in the N-430) to improve limiter characteristics.

For this purpose and to prevent instability due to output feedback to the input side, an adequate shield must be provided and the component parts must be carefully arranged.

The time required for a signal applied to the input of an inter frequency unit to emerge from the output generally varies according to frequency.

In ordinary broadcasting, since the frequency varies in a range of 10.7 MHz \pm 75 KHz, a frequency with a shorter transit time catches up with the preceding signal before emerging as output. This will result in a high frequency. Also, an interval will be opened between a slow signal and the preceding signal which produces a lower frequency. This kind of variation in the transit time occurs mainly in the tuning circuit, resulting in increased distortion.

This is called group delay characteristic and one of the important features of an inter frequency unit.

In the N-430, superior selectivity and group delay characteristics have been realized by employing 4-element Ceramic Filter and Linear Phase Shifter.

The composite signal is taken out by demodulating the FM signal with a discriminator placed in the last stage of the inter frequency unit.

Linearity of the discriminator is very important, and must be regulated with adequate care since poor linearity will result in increasing distortion and poor channel separation.

Good discriminator characteristics are shown in Fig. 2.4 by the solid line, where the output voltage varies in a straight line over the \pm 100 KHz range and voltage is zero at the center frequency. If, as shown by the dotted line, there is asymmetry above and below, the voltage is not zero at the center frequency, and the degree of distortion will increase.

The discriminator of the N-430 has a broad linear zone (\pm 200 KHz or more). As the Self-Locked Tuning of the N-430 will operate 5 - 9 seconds after the tuning. FM broadcast-receiving can be performed under the distortion free condition at all times.

Because the discriminator output is small, it is applied to the MPX IC (PLL) after passing through a DC amplifier

with about 7 dB gain at the initial stage of the MPX unit. The 38 KHz signal which is synchronous with the 19 KHz involved in the composite signal is produced in MPX unit. This leads to separate the L channel and R channel signals (refer to Fig. 2.2).

Therefore, in order to achieve good channel separation, the high end and low end of the 38 KHz waveform must be symmetrical and the phase must be precisely aligned. In the N-430, good channel separation has been realized by means of a stabilized synchronizing signal obtained by a PLL (phase-locked loop) IC.

With this, even if an SCA signal is present, no beat interference can occur.

To obtain a good S/N ratio, pre-emphasis is made on the transmitter side and de-emphasis is made on the receiver side.

The time constant of 75 μ s is mainly employed by the U.S.A. and Canada, and 50 μ s in Europe and other countries including Japan. In Dolby FM broadcasting, the time constant is 25 μ s. Consequently, in the N-430, de-emphasis is made in the MPX unit at 25 μ s and a circuit is provided after the Dolby NR circuit to change the time constant to 75 μ s or 50 μ s.

Changeover of time constant (50 μ s/70 μ s) is made by Emphasis Switch on the Main P.C.B.

This time constant is interlocked with the Dolby NR

switch. The Dolby NR circuit, being highly sensitive to high frequencies, will malfunction when there is a carrier leak from the MPX unit.

Although the 19 KHz pilot signal is especially difficult to remove because of its proximity to the audio signal, the N-430 uses a specially-designed low-pass filter to achieve an attenuation characteristic of 40 dB or more for the 19 KHz signal, while keeping flat frequency response up to 15

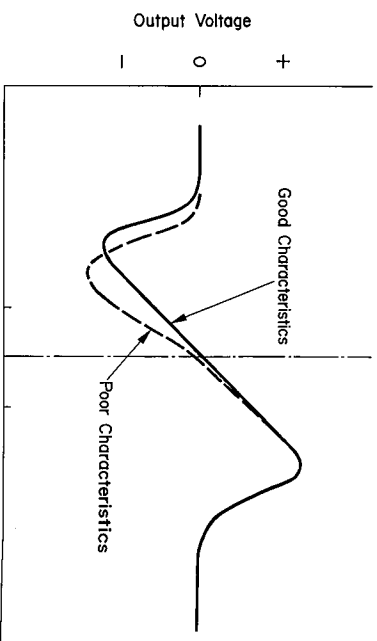

Fig. 2.4 Discriminator Characteristics (S-Curve)

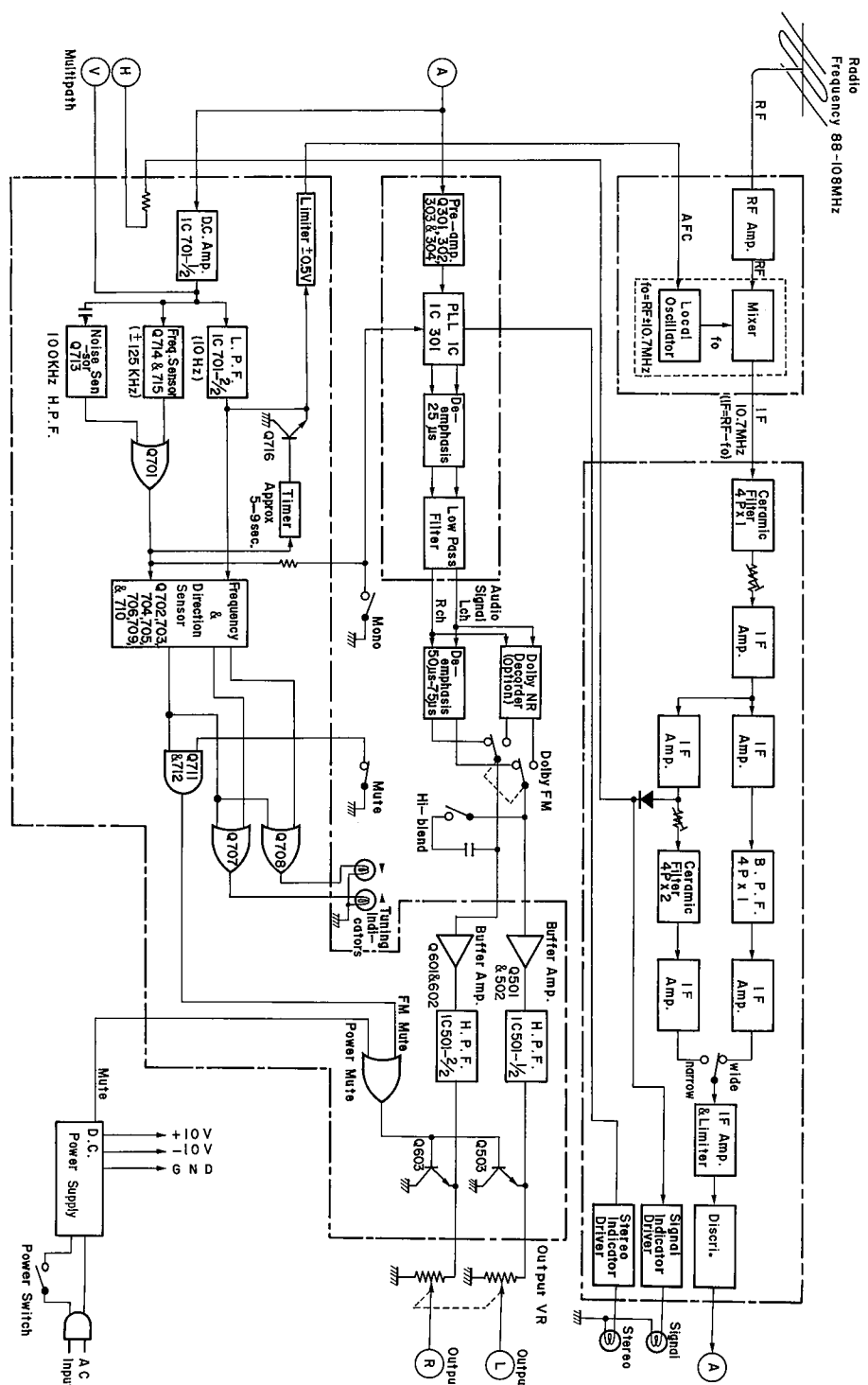

Fig. 2.3 Block Diagram

2.2. Operation of Indicator Logic

Refer to Fig. 2.5, Indicator Logic/High-pass Filter/Output Unit circuit diagram and Fig. 2.3, Block Diagram.

The Discriminator output of IF unit first enters the Indicator Logic, and after having been amplified by IC 701-1/2, it is converted to direct current through Low Pass Filter connected to IC 701-2/2, thus DC voltage output (No. 7 terminal) of the IC 701-2/2 is obtained.

The output of the IC 701-2/2, while tuned, is shown to be 0V DC but will change either to plus or minus voltage within the applicable range if tuning is out of the correct position. The Indicator Logic is thus activated.

The output of IC 701-1/2 is supplied to Frequency Sensor (transistors Q714 and Q715) and Noise Sensor (Q713), and each of the outputs activates Q701 through OR circuit (diode D701). The collector output of Q701 is fed into the Indicator Logic and AFC (Timer circuit: Q716).

By controlling the Tuning Indicators, the Indicator Logic makes the N-430 possible to perform perfect tuning even without tuning meters, forcibly changes the output to monaural when tuning is out of the correct position, and generates mute signal to mute the output signals. The said Indicator Logic is also incorporated in Multipath Detector, Output Buffer Amp. and Subsonic Filter.

(1) Operation of Noise Sensor

Feeds the signals increased 10 times (20 dB) the Discriminator output by IC 701-1/2 to 100 kHz High Pass Filter and then detects high frequency noise to be induced when tuning is out of the position.

When noise is detected, Q713 will become ON and D701 will also become ON as Q701 turns to ON. When Q701 turns to ON, Q716 will also turn to ON, as a result of which AFC will not operate. On the other hand, Q709 and Q710 will turn to OFF and therefore Q711 and Q712 will turn to ON, thus the output signals will be muted (only when Mute Switch is depressed). While the Mute Switch is released, the base of Q711 will become GND level, and therefore Q711 and Q712 will turn to OFF, as a result of which mute will not be activated and interstation noise, etc. will be output from the output jacks. The Tuning Indicators will not be lit as all of Q703, Q705, Q707 and Q708 are turned to OFF.

(2) Function of Frequency Sensor

The output signal of IC701-1/2 (amplified the Discriminator output 10 times) is fed to Frequency Sensor consisting of Q714 and Q715.

Frequency Sensor acts to detect the difference of the frequency from the center frequency (f_0).

This circuit activates to ON when IF frequency differs by ± 125 kHz or more from the center frequency (f_0).

When the output (No. 1 terminal) of IC 701-1/2 is plus, Q714 will turn to ON, but Q715 will turn to ON when minus. Q701 will turn to ON if either Q714 or Q715 turns to ON. The operation of following circuits is identical to that as exemplified in the above (1) Noise Sensor.

(3) Operation while Tuned

While tuning, as the direct current component of the signals from the Discriminator will become 0V DC, the output (No. 7 terminal) of IC 701-2/2 will also become 0V DC, when neither the Frequency Sensor nor Noise Sensor will operate.

Accordingly Q701 will turn to OFF and Q709 and Q710 of the Frequency and Direction Sensor (Q702, Q703, Q704, Q705, Q706, Q709 and Q710) will turn to ON.

With Q710 which turns to ON, base current flows through R728 and R727, and Q707 and Q708 will turn to ON, as a result of which both of the Tuning Indicators will light on.

With Q709 and Q710 set to ON, Q711 and Q712 will turn to OFF, and therefore the output signals will be released from muting. On the other hand Q716 will turn to OFF by Q701 OFF, the output (AFC signal) of IC 701-2/2 will

be fed to RF Unit, thus AFC is activated.

The foregoing operations are subject to the fact that the difference of frequency tuned is within ± 30 kHz from the center frequency (f_0). If the difference exceeds ± 125 kHz from the center frequency (f_0), the Frequency Sensor will then activate to turn Q701 ON.

The collector of Q710 of the Frequency and Direction Sensor will become at high level with Q701 ON, the Tuning Indicators will be lit off as Q703 and Q705 turn to OFF.

With Q711 and Q712 set to ON, both of Q503 and Q603 will turn to ON, the output signals will be muted (only while the Mute Switch is depressed). Meantime, Q716 turns to ON with Q701 ON and leads AFC output to GND, as a result of which AFC will not operate.

(4) Operation while out of tuning within ± 125 kHz to ± 30 kHz

When the tuning becomes closer to high frequency from the center frequency (f_0), minus voltage will be fed to the discriminator output, but plus if closer to lower frequency. Q702, Q704 and Q706 of the Frequency and Direction Sensor form a differential amplifier, and Q705 will turn to ON when the IC 701-2/2 output is plus (Discriminator output is plus) against the Q704 base

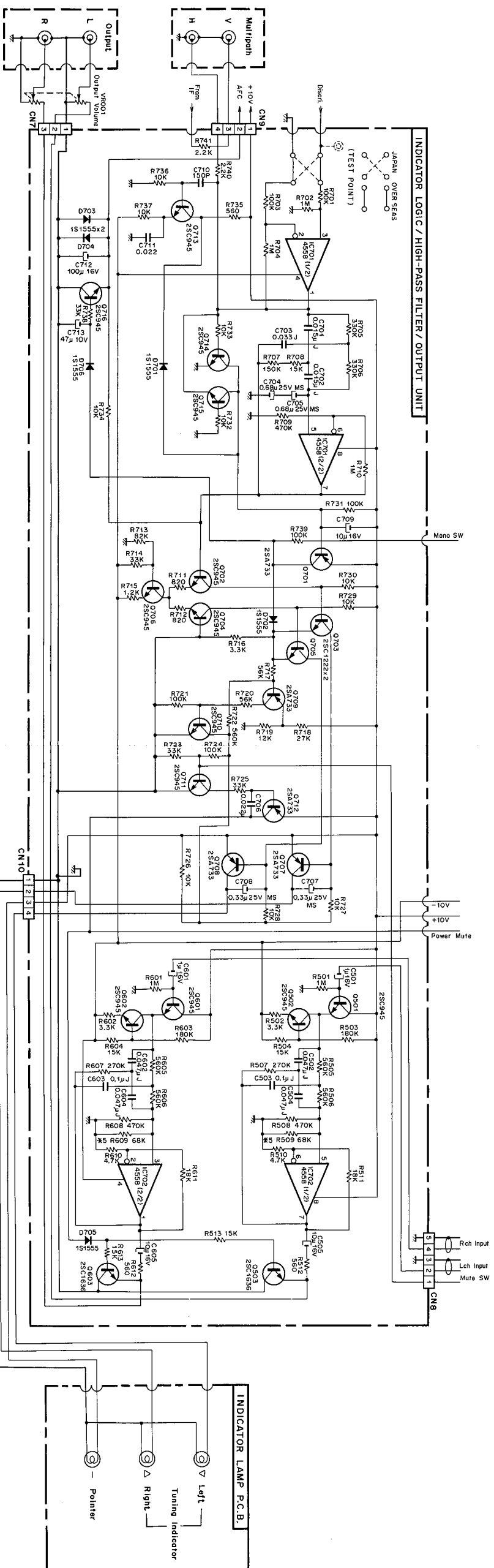

Fig. 2.5 Indicator Logic Circuit

voltage (0 V), thus the Tuning Indicator at left will light ON. Where the minus voltage, Q703 turns to ON and the Tuning Indicator at the right will light ON. Even if there is some difference within the said range, neither the Frequency Sensor nor Noise Sensor activates, therefore Q701 will turn to OFF. As a result Q716 will turn to OFF, and AFC will operate. The voltage in proportion to the difference of frequency will be given to the output of IC 701-2/2 and will become the AFC signals which however will be limited only within ± 0.5 V because of limiters D703 and D704.

In the conventional AFC circuits, it will sometimes become impossible to locate a minor broadcasting station if sandwiched by major broadcasting stations, but the N-430 limits such through its limiter (See Fig. 2.6). As either Q703 or Q705 will turn to ON depending on the direction of out-tuning, the base potential of Q709 will become higher than the emitter potential of Q709, as a result of which Q709 will turn to OFF. Thus Q710 will turn to OFF, and Q711 and Q712 will turn to ON, thus mute will operate (only while Mute Switch is depressed).

(5) Operation in a range of out-tuning (± 125 kHz or more) to tuning

If IF frequency is located more than ± 125 kHz away from the tuning position the Frequency Sensor consisting of Q714 and Q715 operates and lights off the Tuning Indicators. While in this state, as the output signals will be muted (only while the Mute Switch is depressed) and Q701 will turn to ON, Q716 will turn to ON and therefore AFC will not operate.

If you commence to turn with the Tuning Knob from this condition, Tuning Indicator at either right or left will illuminate when tuning becomes within ± 125 kHz. As the Frequency Sensor within this range will not operate, AFC will then operate approximately 5 – 9 seconds afterward. When tuning becomes within ± 30 kHz, both of the Tuning Indicators will light ON, and thus the mute of the output signals will be released.

This AFC circuit is characterized by the fact that there would be a 5 – 9 second period until the AFC circuit activates after the Frequency Sensor stopped functioning, thus enables to obtain center frequency of the tuning station you desire.

(6) Operation of Multipath

As the radio wave from broadcasting stations has a characteristic to go straight forward same as the light, distortion will be created because of the interference between the said straight wave and the wave reflected from the obstacles such as tall buildings, mountains, etc. This is called to be "Multipath". For such reasons, it is important that an FM antenna, to receive FM broadcasts at the utmost condition, be directed to the area where the said multipath is minimum.

And for such reasons, the N-430 incorporates a multipath detecting circuit so that the FM antenna can be directed to the most desirable direction where there is minimum multipath.

AM component detected by the IF Unit is taken out to the Horizontal Terminal. On the other hand, the FM component amplified for 10 times the output from the Discriminator through the Indicator Logic Unit to the Vertical Terminal. The said 2 signals are then connected to vertical terminal and horizontal terminal of an oscilloscope (vertical to vertical, horizontal to horizontal). Then turn an FM antenna gradually to secure the direction where horizontal gain is least, thus multipath is minimized and an FM broadcast under the most desirable condition can be located.

(7) Relation between S-Curve and AFC

Refer to Fig. 2.6. The S-Curve when perfect tuning is completed is shown by curve (1), whereas imperfect tuning for some reasons will be shown either by (2) or (3), when AFC will operate to vary to oscillator frequency (f_0) to become either $-f_0$ to $+f_0$ (variation will depend on the frequency differred). If such variation exceeded the limiter range, the AFC circuit will stop operation and the Frequency Sensor will activate in its place.

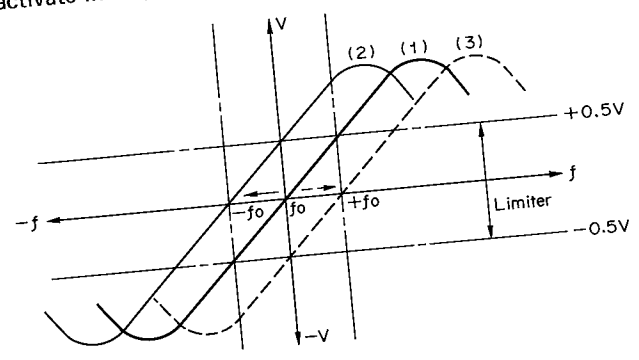

Fig. 2.6 S-Curve and AFC

2.3. Mute Signal

Output signals are muted for a certain period of time to prevent transient noise when power is ON or OFF. Fig. 2.7 shows the mute circuit and Fig. 2.8 shows a timing chart of the mute signal.

Power ON

Transformer output is rectified through diode D403 and smoothed by capacitor C405. Therefore, positive potential appears at C405 (transistor Q409 base). Accordingly, Q409 is in the cut-off state. C406 ($22\ \mu\text{F}$) is charged with negative potential through R415 ($1\ \text{M}\Omega$), therefore at the level where the voltage across C406 exceeds V_{be} (base-emitter voltage) of Q410, Q410 turns from OFF to ON. As a result, Q411 turns ON and the mute signal is changed from $+10\ \text{V}$ to $-10\ \text{V}$, releasing the mute state. (The mute time depends on C406 and R415 after power is ON.)

Power OFF

Transformer output becomes zero and so C405 is charged with negative potential through R414. At the level where the voltage across C405 exceeds V_{be} of Q409, Q409 turns from OFF to ON and C406 is quickly discharged. Thus, Q410 is cut off and Q411 is also cut off. The mute signal voltage becomes positive to mute the output signal. D402 acts to prevent $+10\ \text{V}$ from being discharged easily when power is off.

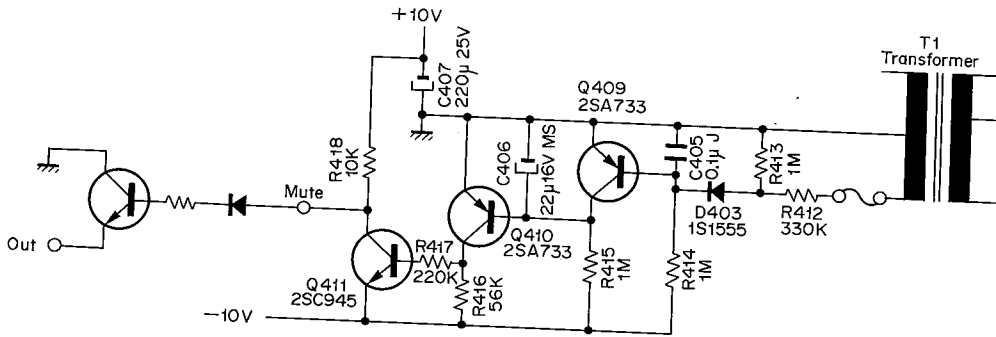

Fig. 2.7 Mute Circuit

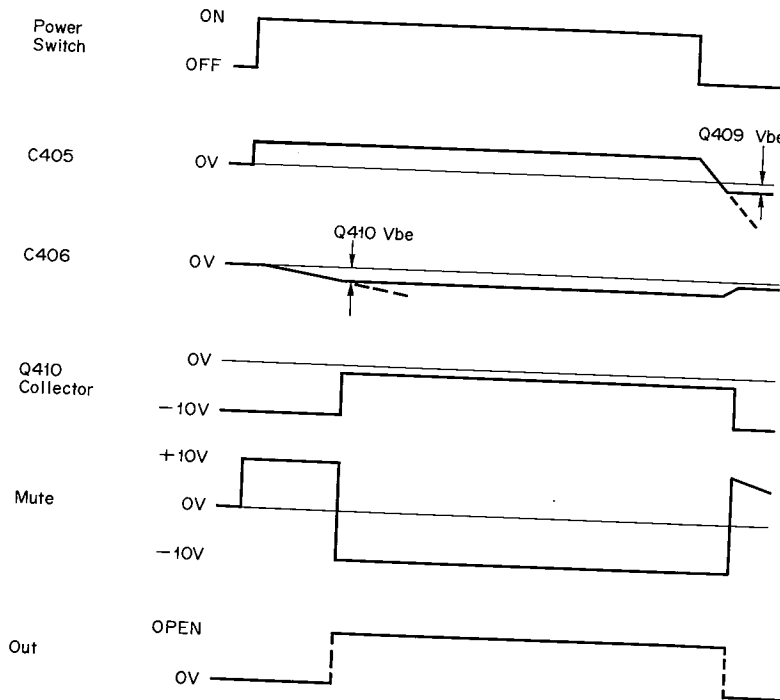

Fig. 2.8 Mute Signal Timing Chart

3. REMOVAL PROCEDURES

3.1. Top Cover, Front Panel Ass'y and Bottom Cover

Refer to Fig. 3.1.

- Disassemble F02 (4 places) then remove F03 (Top Cover 410 including Top Cover Himeleon).
- Loosen F05 (screw M3 x 6 hex. socket head) accessing from the rear side of the Front Panel Ass'y.
- Pull out F07 (Volume Knob Ass'y).
- Disassemble F08 (4 places), then remove F04 (Front Panel Ass'y).
- Disassemble F09 (6 places), then remove F10 (Bottom Cover 430).

3.2. Front Chassis Ass'y

Refer to Fig. 3.2.

- Remove Top Cover referring to above item 3.1.
- Remove F02 (Pulley Spring) from "A" (Front-End Pulley 430), then dismount dial thread by turning it clockwise.
- Pull out connector Nos. 1 - 6 and disassemble F03 (3 places), then remove F04 (Front Chassis Ass'y). (Disassembly of connector Nos. 4 - 6 can be easily performed after F04 (Front Chassis Ass'y) is removed.)

3.3. P.C.B. Assemblies

Refer to Fig. 3.3.

- Remove Top Cover and Bottom Cover referring to above item 3.1.
- Disassemble F02 (2 places) and F03 (P.C.B. Stopper), then remove F04 (MPX P.C.B. Ass'y) and F05 (Dolby NR P.C.B. Ass'y - optional accessory).
- Pull out connector Nos. 1 - 3, 7 and 8, and disassemble F06 (4 places), then remove F07 (Indicator H.P.F. P.C.B. Ass'y).
- Pull out F08 (Pin Plug Ass'y) and disassemble F09 (Pulley Spring and Dial Thread Ass'y) and F10 (4 places), then remove F11 (Front-End 430).
- Remove F12 (screw M3 x 6 hex. socket head), then remove F13 (Front-End Pulley 430).
- Pull out connector Nos. 4 - 6 and 9, and disassemble F14 (4 places), then remove F15 (Main P.C.B. Ass'y).

3.4. Power Supply Ass'y and Rear Panel Ass'y

Refer to Fig. 3.4.

- Remove Top Cover and Bottom Cover referring to above item 3.1.
- Disassemble F01 (2 places), F02 (P.C.B. Stopper), F03 (4 places) and F04 (one place), then remove F05 (Power Supply Ass'y).
- Disassemble F04 (one place), F06 (3 places) and connector No. 8, then remove F07 (Rear Panel Ass'y). (Removal of Rear Panel Ass'y will be completed by unsoldering the signal wires of connector No. 8 connected with Output Pin Jacks of the Rear Panel Ass'y.

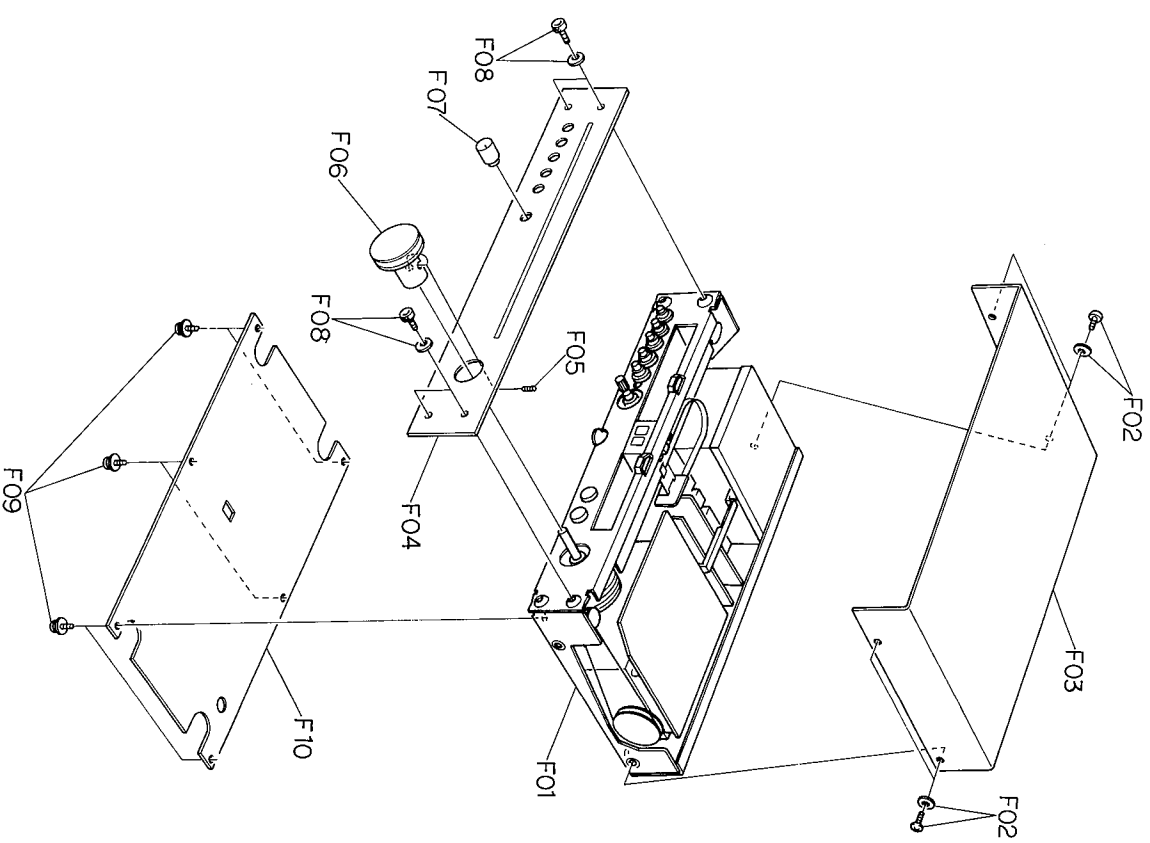

Fig. 3.1

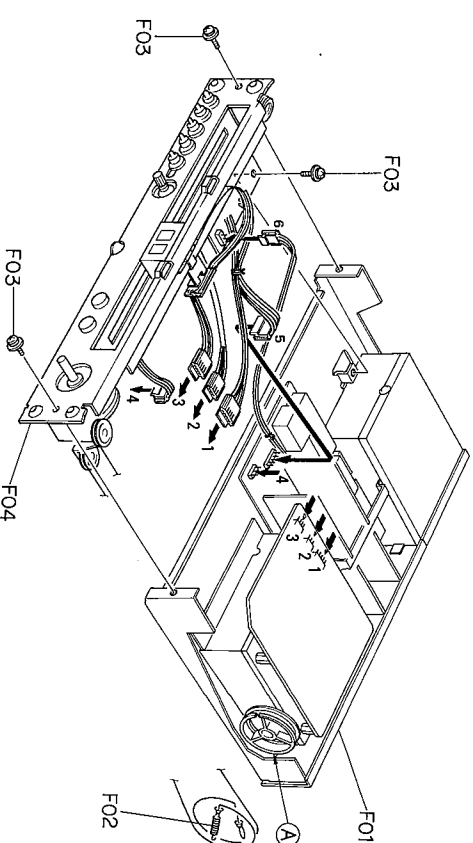

Fig. 3.2

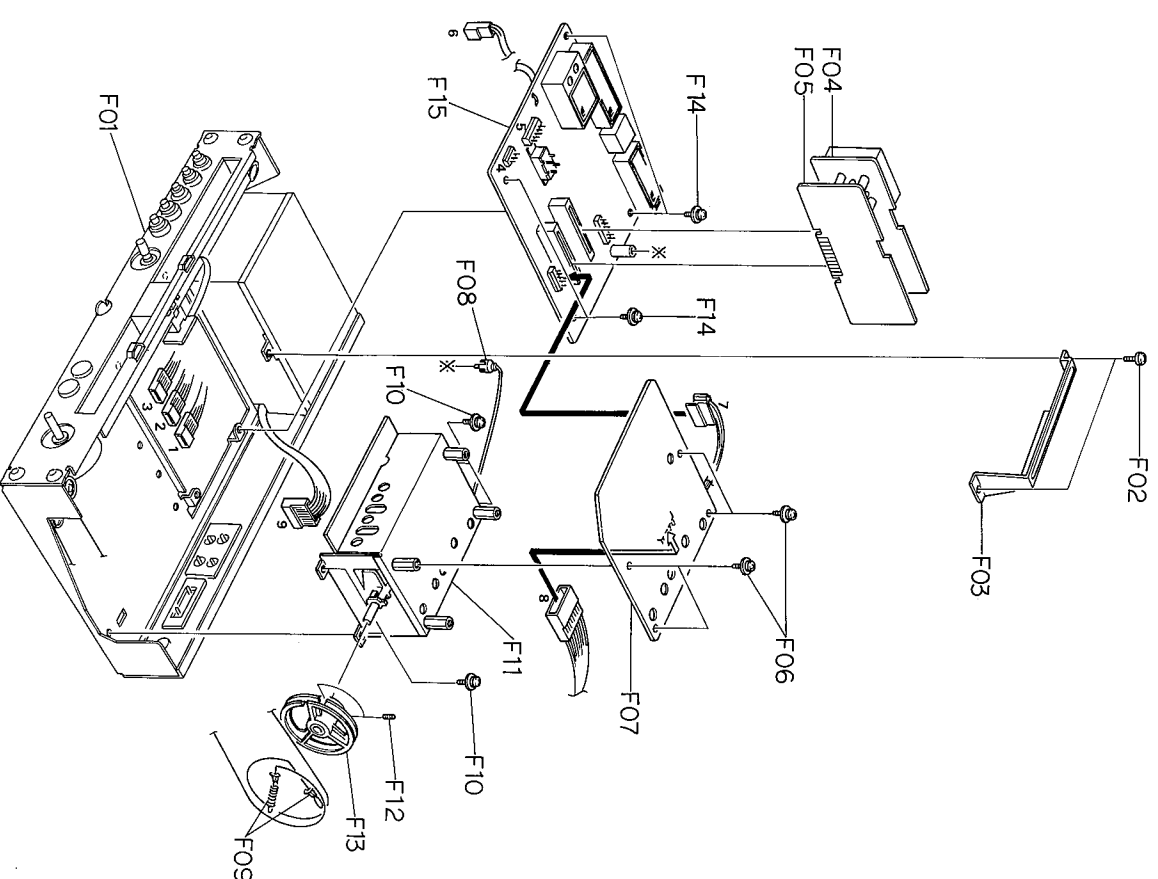

Fig. 3.3

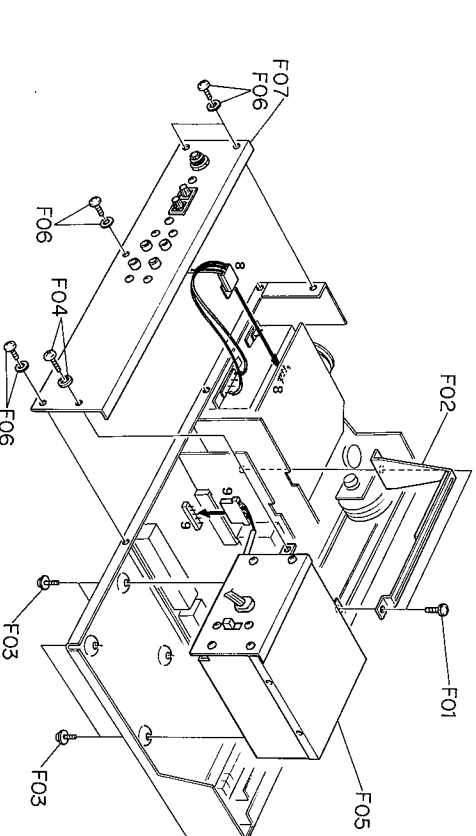

Fig. 3.4

4. ELECTRICAL ADJUSTMENTS AND MEASUREMENTS

The flow-chart for adjustment procedures is illustrated in Fig. 4.1, and positions of the semi-fixed volumes and coils for adjustment are shown in Fig. 4.2, while Fig. 4.3 shows instruments for adjustment and their connecting diagram.

Instruments and devices that should be used for adjustment and measurement of the Nakamichi N-430 are as follows (the connection diagram is referred to in Fig. 4.3):

- Model 1700B Distortion Measurement System
- Model 1100A Signal Conditioner
- Model 1000A FM Alignment Generator
- Dummy Antenna (an accessory to Model 1000A)
- (The above-mentioned are supplied from Sound Technology Inc.)
- Oscilloscope
- Channel Switch Box

As distortion of 430 is less than 0.06% in Mono, the measuring device must keep its distortion much lower than that of 430.

Accordingly the built-in oscillators of ordinary FM generators are not recommendable for the adjustment and measurements. The oscillator (1 KHz, 400Hz) of M-1700B is preferable for such purposes.

Measurement and adjustment must be performed in a shielded room in principle; otherwise, the frequency should be selected so that no broadcasting frequency will become in a range of the selected frequency ± 400 KHz. With all the instruments normally connected, make RF Level of M-1000A FM Alignment Generator to be minimum, and then with Mute SW. of 430 turned OFF (Release), find out a frequency band in which no signal is received by turning Tuning Dial of 430, while listening inter-station noise. A point of any noise tone variation should be avoided because there will be some weak electric wave.

In this adjustment and measurement, the frequency meeting the above requirements should be set, for example, to 98 MHz on the M-1000A FM Alignment Generator.

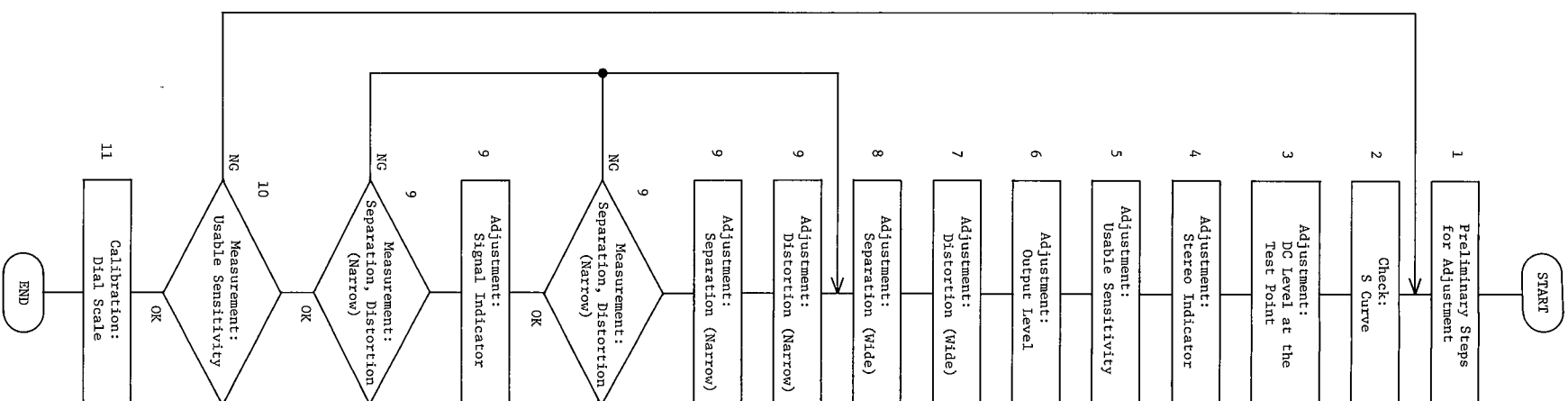

Fig. 4.1 Flow Chart

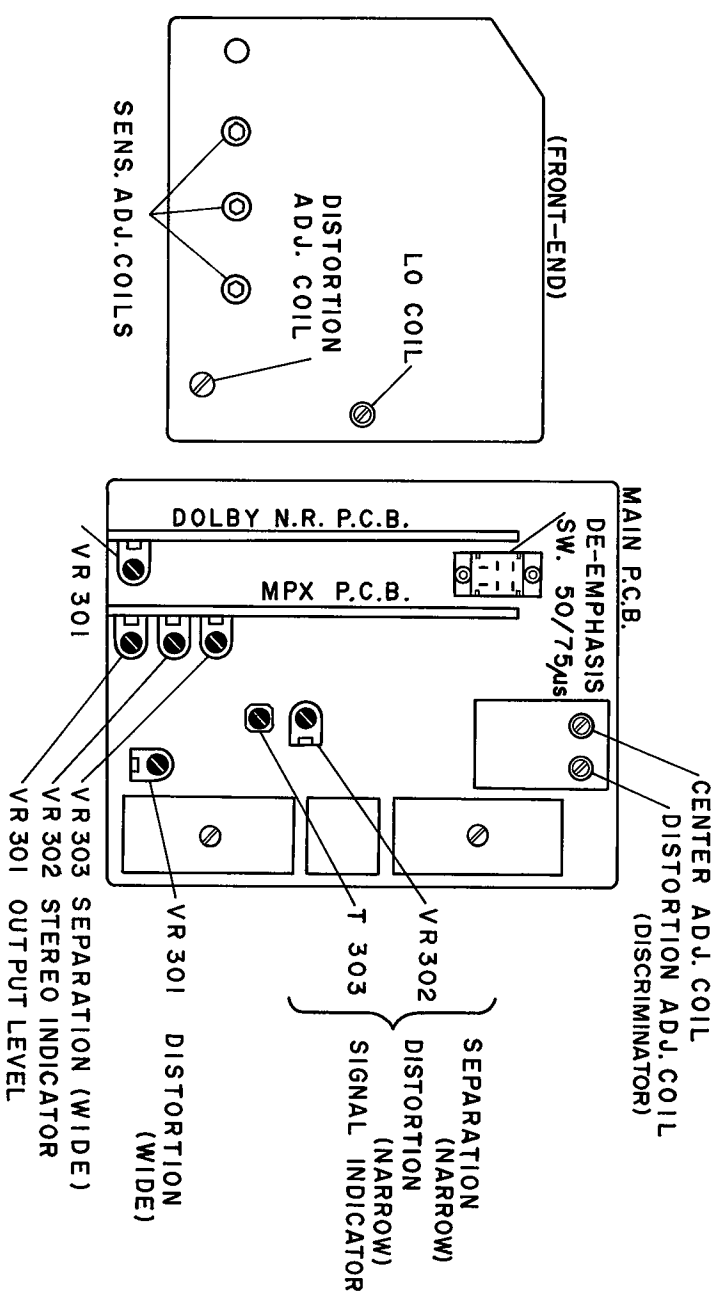

Fig. 4.2 Parts Location for Adjustment

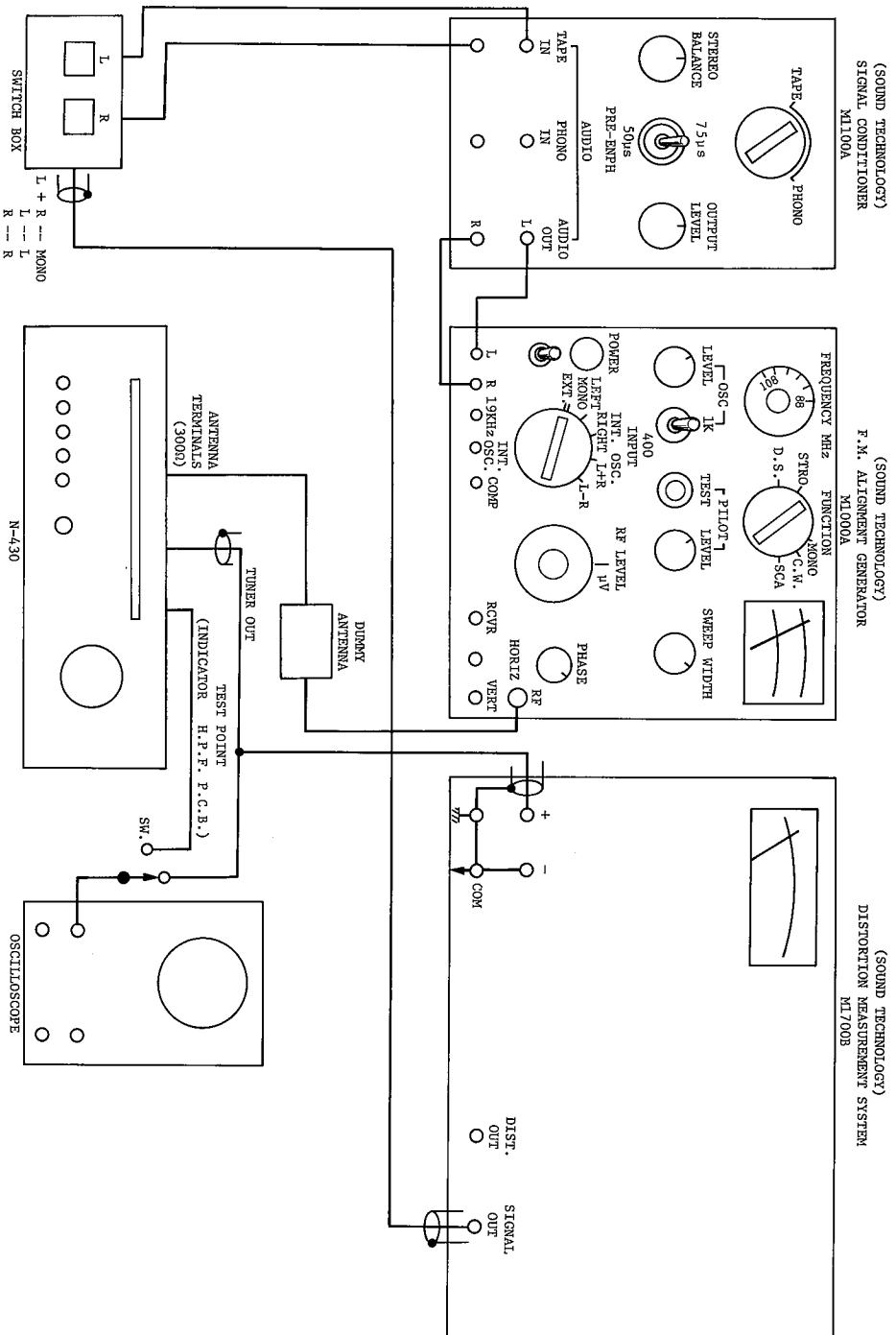

Fig. 4.3 Connection Diagram

STEP	ITEM	OUTPUT CONNECTION	MODE	ADJUSTMENT	REMARKS
1	Preliminary Steps for Adjustment				<ol style="list-style-type: none"> Position a testing pin at the test point (referred to in the circuit diagram) on the Indicator H.P.F. P.C.B. The pin should be removed after adjustment. Connect AFC (CN9-2 pin on the Indicator H.P.F. P.C.B.) to GND. AFC should be returned to the initial state after adjustment. Connect FM Generator to 300-ohm FM Antenna Terminals in N-430. Set the frequency of FM Generator to 98 MHz. (Refer to page 9.) Keep N-430 Mute switch released. Perform the signal modulation for M-1700B (1 kHz, 400 Hz) by adjusting Signal Output VR of M-1700B. The modulation factor is indicated by the meter on M-1000A FM Generator. <p>Note: Adjustment procedures are shown according to the numbers of the flow chart in Fig. 4-1.</p>
2	S-Curve Check	Oscilloscope to Test Point	FM Generator: <ul style="list-style-type: none"> Function — Dual Sweep Sweep Width — 600 kHz RF Level — 1 mV (300 Ω) Narrow SW — Release (Wide) 		<ol style="list-style-type: none"> While observing S-Curve by the Oscilloscope, turn the Tuning Dial on the N-430 so that the S-Curve waveform may become longitudinally symmetrical. Make sure that the S-Curve is symmetrical, with the Narrow switch on the N-430 depressed.
3	DC Level Adjustment	Oscilloscope to Test Point Vertical Gain: DC 0.05 V/cm or more	FM Generator: <ul style="list-style-type: none"> Function — CW RF Level — 1 mV (300 Ω) Narrow SW — Release (Wide) 	Main P.C.B. Center Adj. Coil	Adjust the Center Adj. Coil to obtain 0 V (ground level) (within ± 5mV) on the Oscilloscope.
4	Stereo Indicator		FM Generator: <ul style="list-style-type: none"> Function — Stereo Input Int. OSC. — EXT. RF Level — 1 mV (300 Ω) Pilot Level — 0 Model 1700B: OSC. — 1 kHz, 100% Modulation N-430: Narrow SW — Release (Wide) Mono SW — Release (Stereo) 	MPX P.C.B. VR302	<ol style="list-style-type: none"> With the Pilot Test Switch on the FM Generator depressed, adjust the pilot level to become 100% (pilot signal modulation degree: 9%). Adjust VR302 so that the Stereo Indicator on the N-430 will light up. As the indicator is illuminated in a certain range of VR302, VR302 should be fixed approximately at the center of that range. With the Pilot Test Switch on the FM Generator depressed, adjust the pilot level to become 80% (pilot signal modulation degree: 7.2%). Make sure that the Stereo Indicator goes out on depressing the Mono switch on the N-430. Then make sure that the lamp lights up again by releasing the Mono switch. Readjust the pilot level to become 100%.
5	Usable-Sensitivity Adjustment	Oscilloscope and Distortion Meter to OUTPUT Jacks	FM Generator: <ul style="list-style-type: none"> Function — Stereo Input Int. OSC. — EXT. Model 1700B: OSC. — 1 kHz, 100% Modulation Mode — Distortion Side Switch Box: Lch and Rch — Depress (Mono) N-430: Narrow SW — Release (Wide) Mono SW — Depress (Mono) Output VR — Max. 	Front-end Sens. Adj. Coil	<ol style="list-style-type: none"> Adjust Sens. Adj. Coil so that the distortion will become 3% or less. On adjusting the RF level of the FM Generator, make sure that the level is 1.8 μV (300 Ω) or less when the distortion reaches 3%.

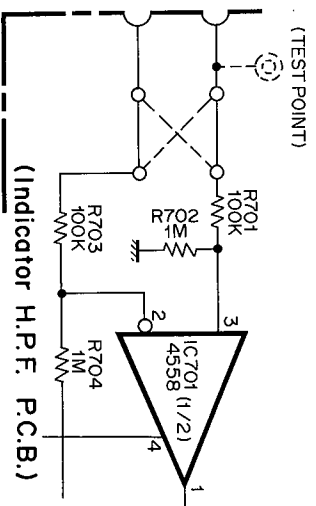

Fig. 4.4 Test Point

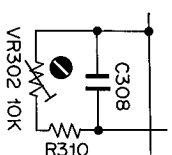

Fig. 4.5 Stereo Indicator

STEP	ITEM	OUTPUT CONNECTION	MODE	ADJUSTMENT	REMARKS
6	Output Level Adjustment	AC Voltmeter to OUTPUT Jacks	FM Generator: <ul style="list-style-type: none"> — Function — Input Int. OSC. — RF Level — Pilot Level Model 1700B: <ul style="list-style-type: none"> — OSC. — Lch Switch Box: <ul style="list-style-type: none"> — Rch — Narrow SW — Mono SW — Output VR N-430: <ul style="list-style-type: none"> — Release (Stereo) — Max. 	MPX P.C.B. VR301	<ol style="list-style-type: none"> 1. At pilot level 0, adjust Signal Output Volume of the M-1700B so that the 400 Hz signal modulation degree is shown to be 50%. Then adjust the pilot level so that the pilot level is 100% (pilot signal modulation degree: 9%). Total modulation degree: 59% 2. With Lch of the Switch Box depressed, adjust VR301 so that the Lch output level will become 500 mV. Then depress the Rch of the Switch Box (Lch is released) and make sure that the Rch output level is also 500 mV. 3. In case optional Dolby NR Circuit Board is incorporated, make sure that the difference of the output levels between Dolby NR switch turned ON and OFF is ± 0.3 dB or less.
7	Distortion Adjustment (Wide)	Distortion Meter to OUTPUT Jacks	FM Generator: <ul style="list-style-type: none"> — Function — Input Int. OSC. — RF Level — Pilot Level Model 1700B: <ul style="list-style-type: none"> — OSC. — Mode Switch Box: <ul style="list-style-type: none"> — Lch — Lch and Rch N-430: <ul style="list-style-type: none"> — Depress (for Stereo adjustment) — Release (Mono) — Narrow SW — Mono SW — Output VR — Max. 	Front-end Distortion Adj. Coil Main P.C.B. VR301 IF Discriminator Distortion Adj. Coil	<ol style="list-style-type: none"> 1. After depressing Mono switch on the N-430 and both Lch and Rch of the Switch Box, adjust Distortion Adj. Coil on the Front-end to obtain minimum distortion. 2. After releasing Mono switch on the N-430 and Rch of Switch Box (Lch is depressed), adjust VR301 on the Main P.C.B. so that the distortion will become 0.08% or less. 3. Depress Mono switch on the N-430 and both Lch and Rch of the Switch Box, and adjust Distortion Adj. Coil in the IF Discriminator so that the distortion will become 0.06% or less.
8	Separation Adjustment (Wide)	AC Voltmeter to OUTPUT Jacks	FM Generator: <ul style="list-style-type: none"> — Function — Input Int. OSC. — RF Level — Pilot Level Model 1700B: <ul style="list-style-type: none"> — OSC. Switch Box: <ul style="list-style-type: none"> — Lch N-430: <ul style="list-style-type: none"> — Rch — Narrow SW — Mono SW — Output VR — Max. 	MPX P.C.B. VR303	<ol style="list-style-type: none"> 1. Depress Lch of the Switch Box, and adjust VR303 so that the difference of the output levels between left and right will become 50 dB or more. 2. Depress Rch of the Switch Box and check that the difference between right and left will become 50 dB or more.
9	Separation and Distortion Adjustment (Narrow) Signal Indicator Adjustment	AC Voltmeter and Distortion Meter to OUTPUT Jacks	FM Generator: <ul style="list-style-type: none"> — Function — Input Int. OSC. — RF Level — Pilot Level Model 1700B: <ul style="list-style-type: none"> — Mode Switch Box: <ul style="list-style-type: none"> — Lch — Rch N-430: <ul style="list-style-type: none"> — Lch and Rch — Narrow SW — Mono SW — Output VR — Max. 	Main P.C.B. T303, VR302	<ol style="list-style-type: none"> 1. Depress Lch or Rch of the Switch Box, and make sure that the difference of the output levels between left and right is shown to be 30 dB or more. In case the above value does not comply with the specified one, adjust T303 and VR302 until a satisfactory result is obtained. 2. Depress Lch or Rch of the Switch Box, and make sure that the distortion at the Lch or Rch Output will become 0.5% or less. Then Depress both Lch and Rch of the Switch Box and Mono switch on the N-430, and make sure that the distortion is 0.2% or less. In case the above value does not comply with the specified one, adjust T303 and VR302 until a satisfactory result is obtained. When readjusting T303 and VR302, make sure that the above 1 (separation) will become in a specified range. 3. Repeat the above 1 (separation) and 2 (distortion) until a satisfactory result is obtained. 4. Set the RF level of the FM Generator to 300 μV — 400 μV, and make sure till the Signal Indicator on the N-430 illuminates. In case the Signal Indicator does not illuminate, adjust T303 and VR302 until a satisfactory result is obtained. When readjusting T303 and VR302, make sure that the above 1 and 2 are located in their specified ranges.

STEP	ITEM	OUTPUT CONNECTION	MODE	ADJUSTMENT	REMARKS
10	Usable-Sensitivity Measurement	Distortion Meter to OUTPUT Jacks	FM Generator: Function — Stereo Input Int. OSC. — EXT. Pilot Level — 100% Model 1700B: OSC. — 1 KHz, 100% Modulation Mode — Distortion Side Switch Box: Lch and Rch — Depress (Mono) N-430: Narrow SW — Release (Wide) Mono SW — Depress (Mono) Output VR — Max.		Decrease RF level of the FM Generator, and make sure of the RF level to be $1.8 \mu\text{V}$ (300Ω) or less when the distortion reaches 3%. In case the above value does not comply with the specified one, stricter readjustment starting from step 2 "S-Curve Check" will be necessary.
11	Dial Calibration			Front-end LO	<ol style="list-style-type: none"> With Broadcasting Frequency Connect an antenna to the N-430. While receiving from the station with its frequency already known at or near 98 MHz, set the Tuning Dial on the N-430 to that frequency. Adjust LO (local oscillator) Coil on the Front-end till the Signal Indicator and Tuning Indicators of the N-430 illuminate. With FM Generator Connect FM Generator to the antenna terminal of the N-430. Set the frequency to 98 MHz (frequency should be checked with a frequency counter). Adjust LO Coil on the Front-end till the Signal Indicator and Tuning Indicators of the N-430 illuminate.
12	Dolby NR Circuit (Option)			Dolby NR P.C.B. VR301	Equipment to be used: Model 1700B Distortion Measurement System (from Sound Technology Inc.) <ol style="list-style-type: none"> Supply +10 V DC to Dolby NR P.C.B. terminal No. "1" and -10 V to "2". Short "3" and "7" to ground. Connect "Signal Out" terminal of the Model 1700B to "6", and AC voltmeter of the Model 1700B to "5". Apply 5 kHz signals to "6", and adjust the signal output level of the Model 1700B so that the voltage at "5" may read 59 mV. After shorting "4" and "5", adjust VR301 so that the "5" drops by 8 ± 0.25 dB in the voltage. Without changing the signal output level, apply 5 kHz signals to "8" and check that the voltage at "9" is 59 mV. Short "9" and "10", and make sure that the "9" drops by 8 ± 0.25 dB in the voltage.

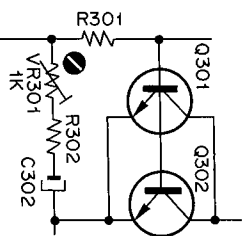

Fig. 4.6 Output Level

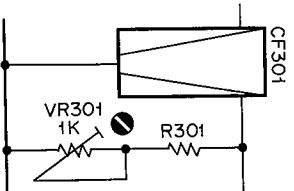

Fig. 4.7 Distortion (Wide)

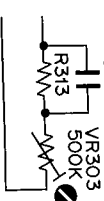

Fig. 4.8 Separation (Wide)

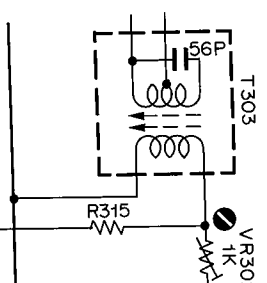

Fig. 4.9 Separation and Distortion (Narrow) and Signal Indicator

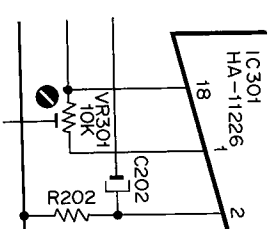

Fig. 4.10 Dolby NR Circuit

5. DIAL THREADING

5.1. How to Prepare the Dial Thread

At an end of the thread, make a ring of about 3.4 mm ID and fix a thread guide in the ring. Refer to Fig. 5.1.

Note: The length of the thread between the thread

guide at one end and the other should be about 1,250 mm. After crushing the thread guide with pliers, adhere the guide and ring with AVDEL BOND #C-2.

Thread: Hamilton Super 505 (Wadding: Aramid (Kevlar)); Braided: Nylon Rope with a length of 1,250 mm.

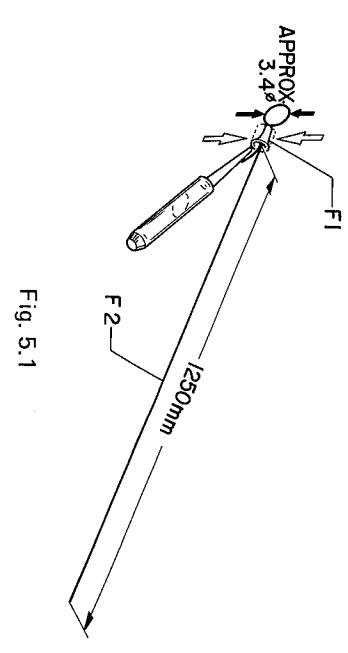

Fig. 5.1

5.2. How to Fit Front-end Pulley 430

Refer to Figs. 5.2 and 5.3.

(1) Fully turn the shaft at the Front-end counter-clockwise.

(2) Insert Front-end Pulley 430 into the shaft at the Front-end and fix Rib A so as to become perpendicular to chassis with a gap of 0.2 – 0.3 mm to the stopper part of Front-end.

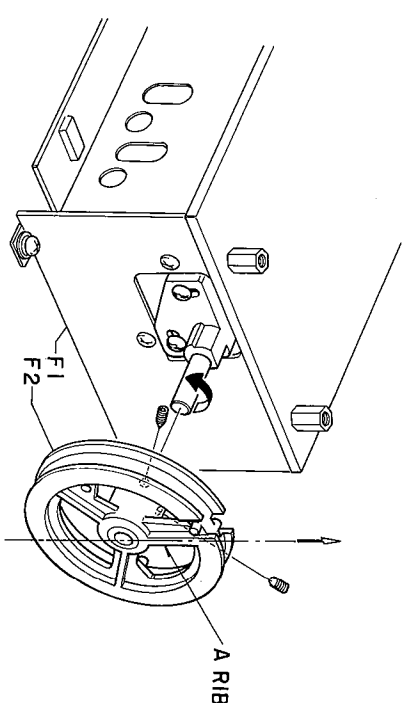

Fig. 5.2

5.3. How to Set Dial Threading

(1) Referring to Fig. 5.4, set a dial thread from the front-end side of F1 (Front-end Pulley 430) to the protrusion of F1.

(2) Referring to Fig. 5.5, wind the thread two turns on F4 (Tuning Shaft) by way of F2 and F3 (Guide Pulleys) in the direction from the Flywheel side to the Front-end, and wind the thread 1-1/2 turns on F1 (Front-end Pulley 430) from the under side of F1 by way of F5 (Guide Pulley).

(3) Referring to Fig. 5.6, put the dial thread end (free end) on F6 (Thread Guide) and fix it with F7 (Pulley Spring).

(4) Referring to Fig. 5.7, hook a Pulley Spring in a Front-end Pulley 430 hole. Pull the dial thread so that a space of 5 – 6 mm can be obtained between the protrusion of Front-end Pulley 430 and the Thread Guide. After rounding off the thread guide with pliers, fix it by applying AVDEL BOND #C-2. Note: AVDEL BOND #C-2 should be applied to strengthen adherence of the thread to the guide. Care should also be taken while bonding not to apply excessive adhesive to any other part.

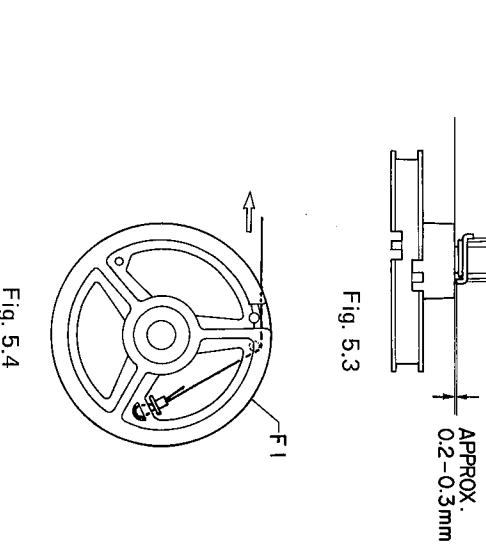

Fig. 5.3

Fig. 5.4

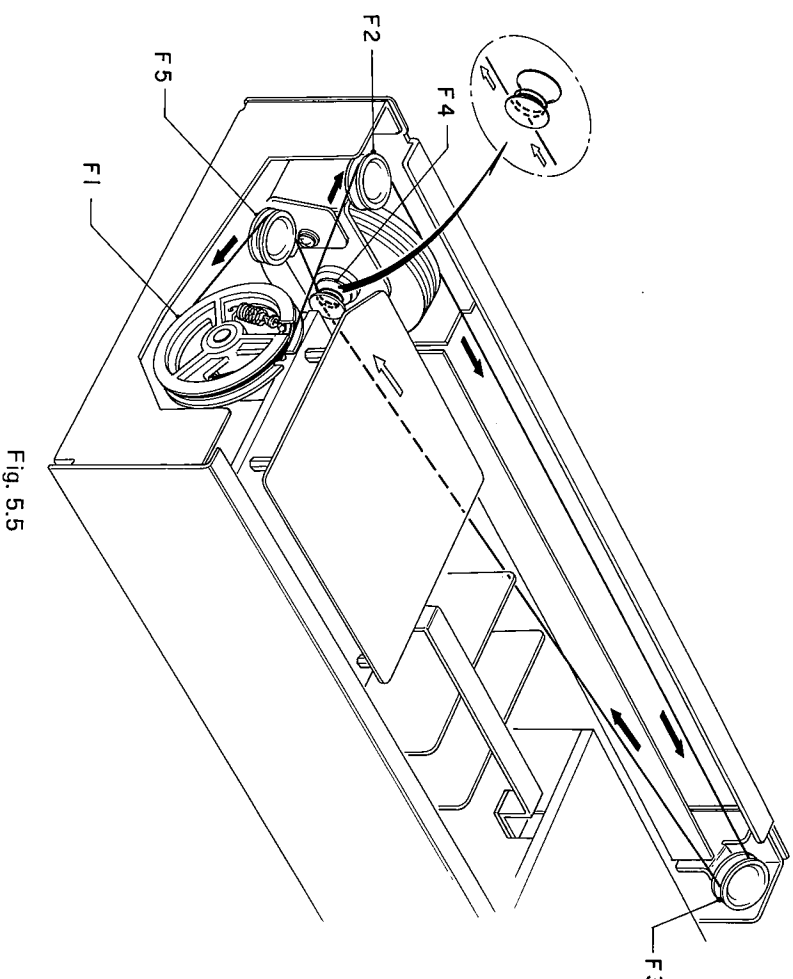

Fig. 5.5

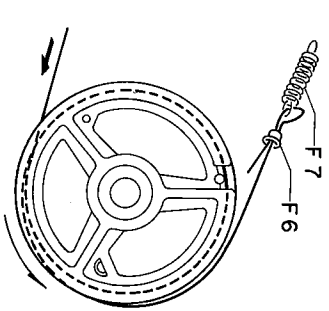

Fig. 5.6

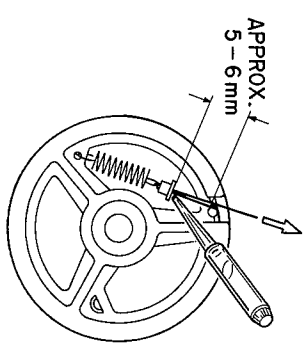

Fig. 5.7

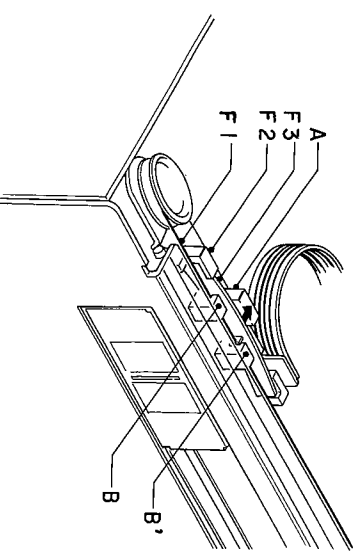

Fig. 5.8

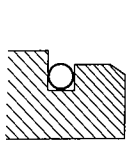

Fig. 5.9

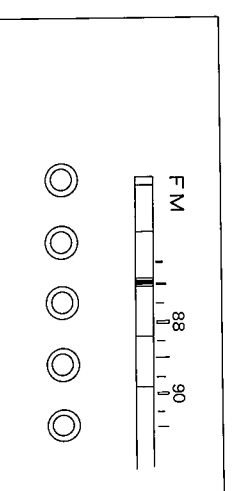

Fig. 5.10

(5) Referring to Figs. 5.8 and 5.9, hold the protrusion A of F2 (Light Intercepting Box) and F3 (Stopper Spring) with pliers. Set F1 (dial thread) into the groove on the protrusions B and B' of Light Intercepting Box and return the Stopper Spring to its initial position (remove the pliers).

Note: In setting the dial threading the Light Intercepting Box, fully turn Tuning Dial counter-clockwise so that the red pointer on Dial Scale is fitted to the graduation next to the left end as shown in Fig. 5.10.

6. MOUNTING DIAGRAMS AND PARTS LIST

- Notes: 1. Mounting diagram shows a dip side view of the printed circuit board.
2. Diode 1S1555 is compatible with FDH-999.

6.1. Main P.C.B. Ass'y

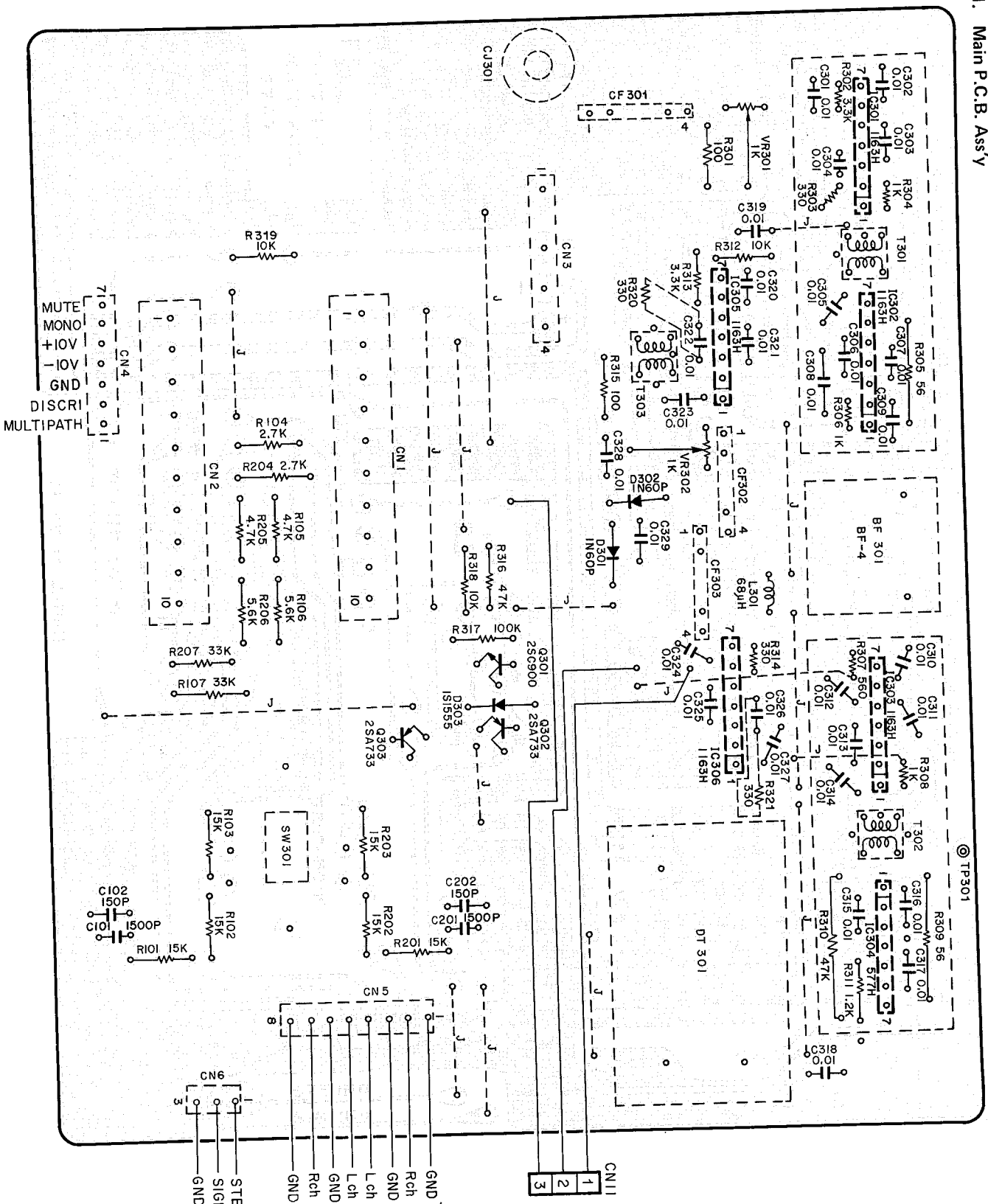

Fig. 6.1

Schematic Ref. No.	Part No.	Description
CJ301	0M03836A	Detector Block Label (1 pce.)
	0M03837A	IF Amp. Block Label (2 pcs.)
	0B08384A	Pin Jack Connector (1 pce.)
	0E00124A	Screw M2x4 Phillips Pan Head (2 pcs.)
	0B08376B	3P-H Connector Ass'y 47-1 (1 pce.)

Schematic Ref. No.	Part No.	Description
	BA03869C	Main P.C.B. Ass'y
	— IF —	
IC301, 302	0B06117A	Linear IC μ PC1163H
303, 305		
306	0B06114A	Linear IC μ PC577
IC304	0B00030A	Germanium Diode 1N60P
D301, 302	0B06571A	IF Coil
T301, 302		
303		
L301	0B06561A	Inductor 69 μ H
VR301, 302	0B07178A	Semi-fixed Volume 1K
R301, 315	0B01679A	Carbon Resistor ERD-25T J
R302	0B01793A	Carbon Resistor 3.3K ERD-25V J
R303, 314	0B01789A	Carbon Resistor 330 ERD-25V J
R304, 306	0B01781A	Carbon Resistor 1K ERD-25V J
308		
R305, 309	0B05890A	Carbon Resistor 56 ERD-25T J
R307	0B05678A	Carbon Resistor 560 ERD-25V J
R310	0B05641A	Carbon Resistor 47K ERD-25T J
R311	0B05623A	Carbon Resistor 1.2K ERD-25T J
R312	0B01888A	Carbon Resistor 10K ERD-25T J
R313	0B01681A	Carbon Resistor 3.3K ERD-25T J
C301-329	0B01290A	Ceramic Capacitor 0.01 μ 50V
CF301, 302	0B08341A	Ceramic Filter
303		
BF301	0B08373A	B.P.F. Block (10.7 MHz)
DT301	0B08293A	Detector Block DB-1
	— STE, Signal Indicator —	
Q301	0B01910A	Transistor 2SC900
Q302, 303	0B06013A	Transistor 2SA733
D303	0B01909A	Silicon Diode 1S1555
R101, 102	0B01683A	Carbon Resistor 15K ERD-25T J
103, 201		
202, 203		
R104, 204	0B05629A	Carbon Resistor 2.7K ERD-25T J
R105, 205	0B01846A	Carbon Resistor 4.7K ERD-25T J
R106, 206	0B01887A	Carbon Resistor 5.6K ERD-25T J
R107, 207	0B05509A	Carbon Resistor 33K ERD-25T J
R316	0B05562A	Carbon Resistor 47K ERD-25T J
R317	0B01889A	Carbon Resistor 100K ERD-25T J
R318, 319	0B01888A	Carbon Resistor 10K ERD-25T J
R320, 321	0B05577A	Carbon Resistor 10K ERD-25T J
C101, 201	0B05653A	Carbon Resistor 330 ERD-25T J
C102, 202	0B05599A	Mylar Capacitor 1500P 50V J
	— Miscellaneous —	
	0B07731C	Main P.C.B.
CN1, 2	BA03807A	10P Connector Ass'y
CN3	0B08127A	4P Plug Pin
CN4	0B08302A	7P-T Post
CN5	0B08334A	8P-T Post
CN6	0B08185A	3P-T Post
CN6	0B07125A	Slide Switch
SW301	0B03924A	FET Gate Pin
TP301	0U03730A	Shield Case
	0U03731B	Shield Cover
	0U03732B	Shield Cover
	0E00176A	Nut Hex. M2

6.4. Dolby NR P.C.B. Ass'y (Option)

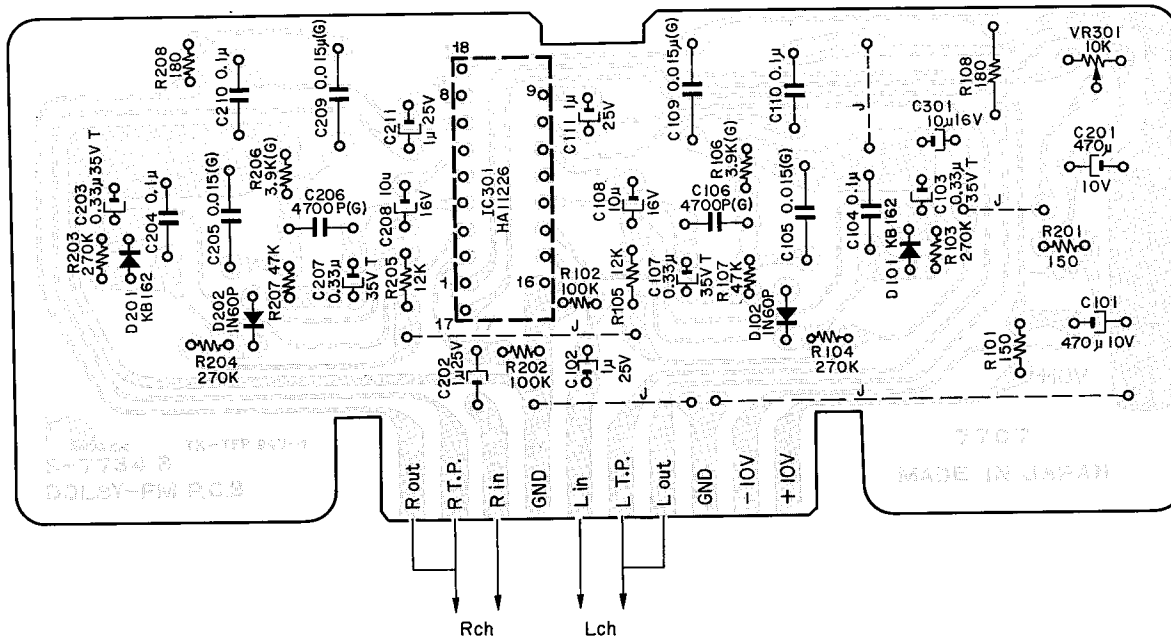

Fig. 6.4

Schematic Ref. No.	Part No.	Description
	BA03879A	DOLBY NR P.C.B. Ass'y
	0B07734B	DOLBY NR P.C.B.
IC301	0B06118A	IC HA11226
D101, 201	0B01599A	Silicon Varistor KB162
D102, 202	0B00030A	Germanium Diode 1N60P
VR301	0B07162A	Semi-fixed Volume 10K
R101, 201	0B05649A	Carbon Resistor 150 ERD-25V J
R102, 202	0B01920A	Carbon Resistor 100K ERD-25V J
R103, 104 203, 204	0B05600A	Carbon Resistor 270K ERD-25V J
R105, 205	0B05650A	Carbon Resistor 12K ERD-25V J
R106, 206	0B05948A	Metal Film Resistor 3.9K ER0-25VK G
R107, 207	0B05562A	Carbon Resistor 47K ERD-25V J
R108, 208	0B05607A	Carbon Resistor 180 ERD-25V J
C101, 201	0B05884A	Electrolytic Capacitor 470μ 10V
C102, 202 111, 211	0B01173A	Electrolytic Capacitor 1μ 25V
C103, 103 203, 207	0B05949A	Tantalum Capacitor 0.33μ 35V
C104, 110 204, 210	0B01780A	Mylar Capacitor 0.1μ 50V J
C105, 109 205, 209	0B05950A	P.P. Capacitor 0.015μ 100V G
C106, 206	0B05951A	P.P. Capacitor 4700P 100V G
C108, 208 301	0B01412A	Electrolytic Capacitor 10μ 16V

6.5. Switch P.C.B. Ass'y

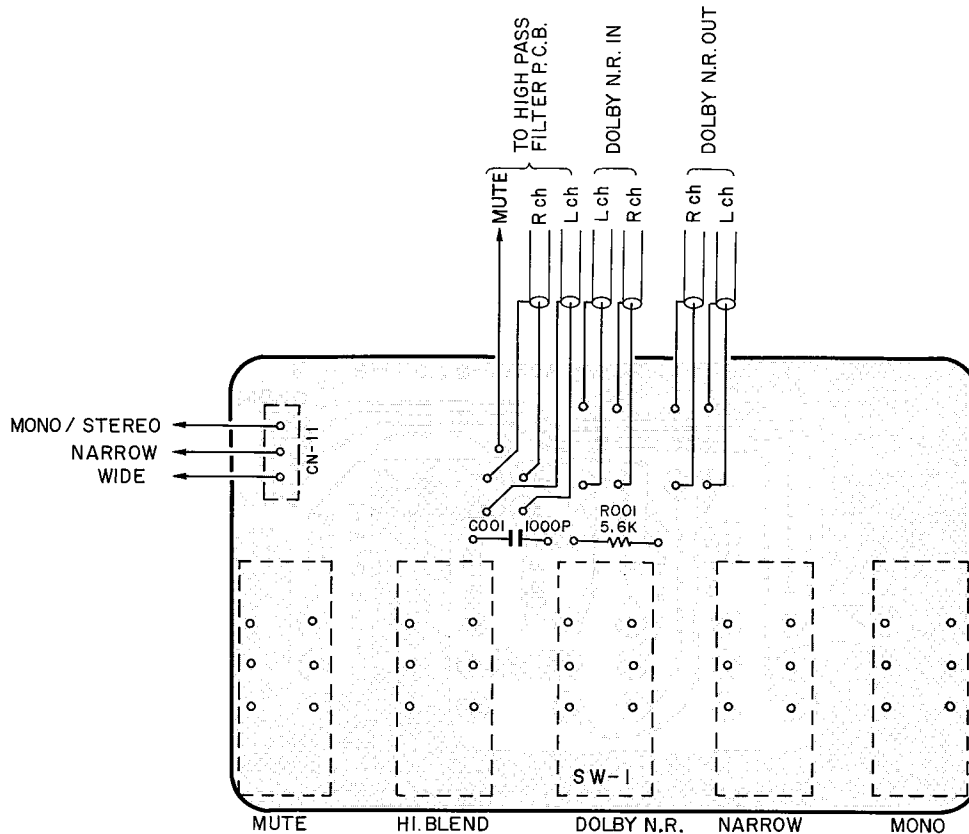

Fig. 6.5

6.6. Lamp P.C.B. Ass'y

Mounting diagram is omitted (refer to item 7.6 Front Chassis Ass'y (A03) No. 18 on page 24).

6.7. Stereo Lamp P.C.B. Ass'y

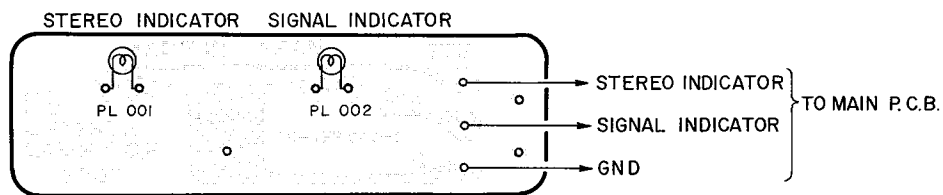

Fig. 6.6

Schematic Ref. No.	Part No.	Description	Schematic Ref. No.	Part No.	Description
	BA03872A	Switch P.C.B. Ass'y		BA03875A	Lamp P.C.B. Ass'y
R001	OB07735A	Switch P.C.B.		OB07736A	Indicator Lamp P.C.B.
C001	OB01887A	Carbon Resistor 5.6K ERD-25T J		OB08391A	4P-H Connector Ass'y 47-2 (1 pce.)
CN5	OB05550A	Mylar Capacitor 1000P 50V J		OB08393A	Indicator Lamp 47 12V 60mA (3 pcs.)
CN8	OB08381A	8P-H Connector Ass'y 47-1			
CN11	OB08380B	5P-H Connector Ass'y 47-1		BA03874A	Stereo Lamp P.C.B. Ass'y
	OB08185A	3P-T Post		OB07737A	Lamp P.C.B.
	OB07176A	Push Switch (1 pce.)	PL001, 002	OB08389A	Lamp 12V 40mA (2 pcs.)
				OB08385A	3P-H Connector Ass'y 47-3 (1 pce.)

6.8. Power Supply P.C.B. Ass'y

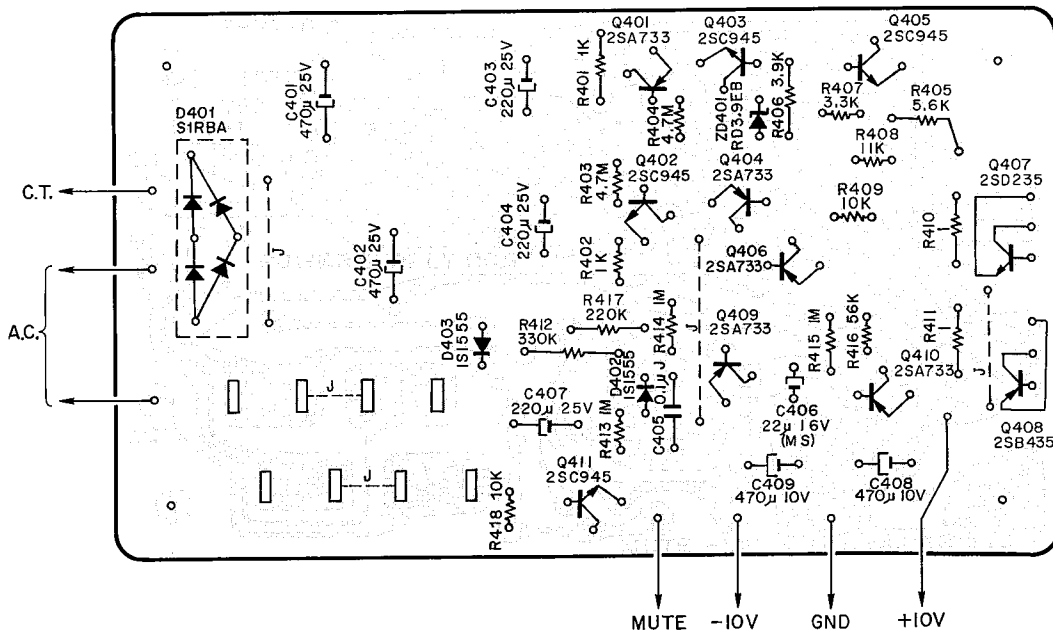

Fig. 6.7

Schematic Ref. No.	Part No.	Description	Schematic Ref. No.	Part No.	Description
	BA03873A	Power Supply P.C.B. Ass'y		0J03728A	Heat Sink 47 (1 pce.)
				0J03729A	P.C.B. Holder 47 (1 pce.)
				0B08382A	4P Jack Ass'y 47-1 (1 pce.)
				0E00606A	Screw M3x6 Philips Pan Head (3A) (4 pcs.)
				0E00607A	Screw M3x8 Philips Pan Head (3A) (2 pcs.)
				0E00507A	Nut Hex. M3 (2 pcs.)
Q401, 404, 406, 409, 410	0B07730B 0B06013A	Power Supply P.C.B. Transistor 2SA733			
Q402, 403, 405, 411	0B01872A	Transistor 2SC945			
Q407	0B01823A	Transistor 2SD235			
Q408	0B06011A	Transistor 2SB435			
ZD401	0B06122A	Zener Diode RD3.9EB			
D401	0B06088A	Silicon Diode S1RBA			
D402, 403	0B01909A	Silicon Diode 1S1555			
R401, 402	0B01781A	Carbon Resistor 1K ERD-25V J			
R403, 404	0B05824A	Carbon Resistor 4.7M ERD-50T J			
R405	0B05673A	Carbon Resistor 5.6K ERD-25V J			
R406	0B05664A	Carbon Resistor 3.9K ERD-25V J			
R407	0B01793A	Carbon Resistor 3.3K ERD-25V J			
R408	0B05826A	Carbon Resistor 11K ERD-25V J			
R409, 418	0B01833A	Carbon Resistor 10K ERD-25V J			
R410, 411	0B05746A	Carbon Resistor 1 ERD-25V J			
R412	0B01921A	Carbon Resistor 330K ERD-25V J			
R413, 414, 415	0B05564A	Carbon Resistor 1M ERD-25V J			
R416	0B05563A	Carbon Resistor 56K ERD-25V J			
R417	0B05596A	Carbon Resistor 220K ERD-25V J			
C401, 402	0B01401A	Electrolytic Capacitor 470μ 25V			
C403, 404, 407	0B01391A	Electrolytic Capacitor 220μ 25V			
C405	0B01780A	Mylar Capacitor 0.1μ 50V J			
C406	0B05820A	Electrolytic Capacitor 22μ 16V M (MS)			
C408, 409	0B05884A	Electrolytic Capacitor 470μ 10V			

7. MECHANISM ASS'Y AND PARTS LIST

7.1. Synthesis Mechanism Ass'y (K01)

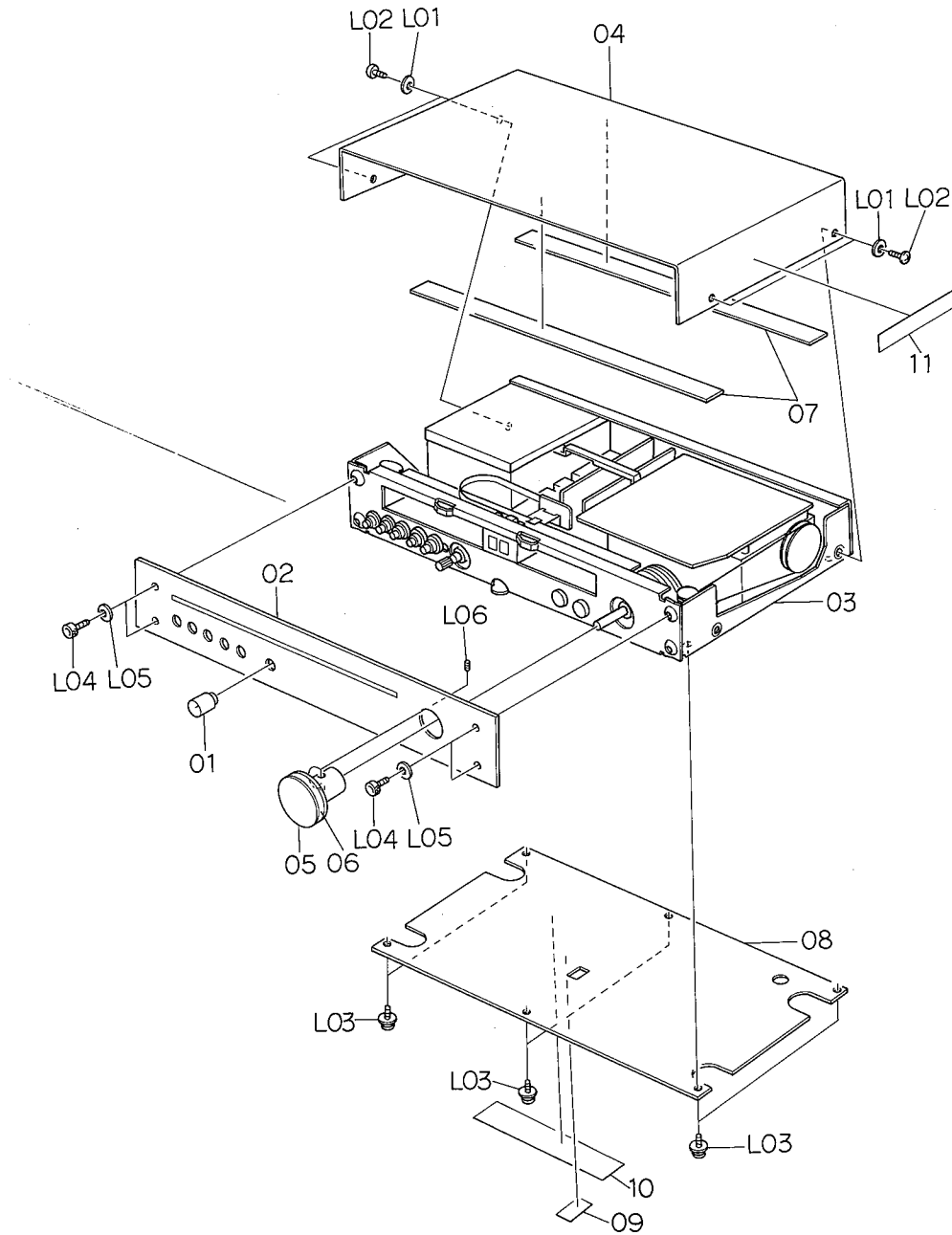

Fig. 7.1

Schematic Ref. No.	Part No.	Description	Q'ty	Schematic Ref. No.	Part No.	Description	Q'ty
K01	JA03182A	Synthesis Mechanism Ass'y		09	0M03838A	De-emphasis Label	1
01	HA03714A	Volume Knob Ass'y	1	10	0M03330A	Dolby NR Label ZT	1
02	HA03719A	Front Panel Ass'y	1	11	0M03799A	Caution Label G	1
	HA03765A	Front Panel Ass'y (Japan)	1	L01	0E00157A	Washer 3mm Plastics	4
03	JA03184A	Tuner Mechanism Ass'y	1	L02	0E00593A	Screw M3x6 Philips Binding Head (Bronze)	4
04	0H03485B	Top Cover 410	1	L03	0E00606A	Screw M3x6 Philips Pan Head (3A)	6
05	0H03536B	Tuning Knob	1	L04	0E00747A	Bolt M4x15 Hex. Socket Head	4
06	0H03537B	Rubber Ring	1	L05	0J03556A	Washer 4mm	4
07	0J03580A	Top Cover Himelon	2	L06	0E00755A	Screw M3x6 Hex. Socket Head	2
08	0J03703A	Bottom Cover 430	1				

7.2. Tuner Mechanism Ass'y (K02)

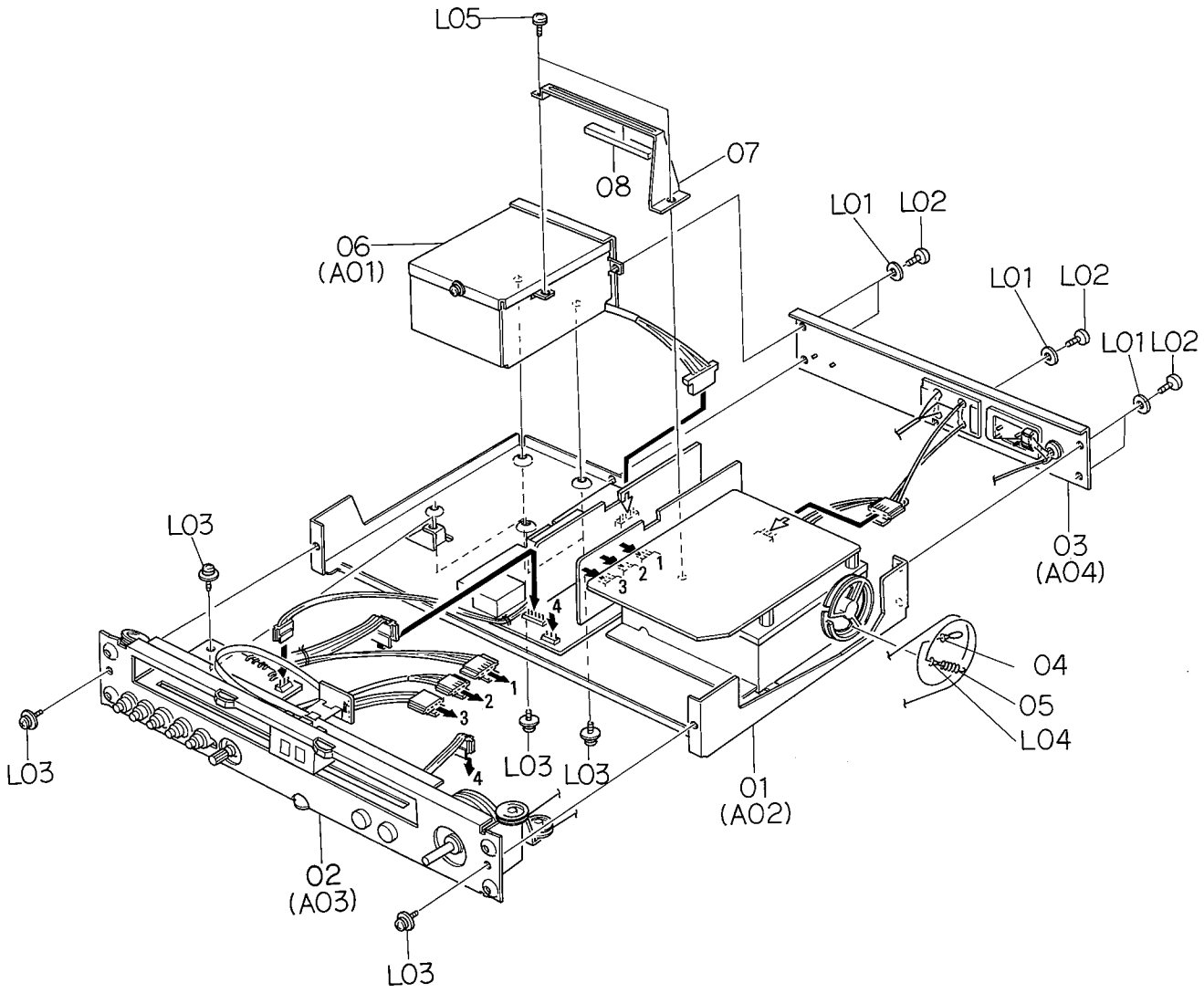

Fig. 7.2

Schematic Ref. No.	Part No.	Description	Q'ty	Schematic Ref. No.	Part No.	Description	Q'ty
K02	JA03184A	Tuner Mechanism Ass'y	1	08	0J03733A	P.C.B. Stopper Pad	1
				L01	0E00157A	Washer 3mm Plastics	5
				L02	0E00593A	Screw M3x6 Philips Binding Head (Bronze)	5
01	JA03186A	Main Chassis Ass'y	1				
02	JA03187A	Front Chassis Ass'y	1				
03	JA03188A	Rear Panel Ass'y	1	L03	0E00606A	Screw M3x6 Philips Pan Head (3A)	7
04	JA03195A	Dial Thread Ass'y	1	L04	0E00752A	Thread Guide	1
05	0J03706A	Pulley Spring	1	L05	0E00612A	Screw M3x6 Philips Pan Head (2A)	2
06	JA03196A	Power Supply Ass'y 120V (U.S.A.)	1				
	JA03197A	Power Supply Ass'y 120V (Canada)	1				
	JA03198A	Power Supply Ass'y 100V (Japan)	1				
	JA03199A	Power Supply Ass'y 240V	1				
	JA03200A	Power Supply Ass'y 220V (1)	1				
	JA03201A	Power Supply Ass'y 220V/240V	1				
	JA03207A	Power Supply Ass'y 220V (2)	1				
07	0J03704A	P.C.B. Stopper	1				

7.3. Front Panel Ass'y (K03)

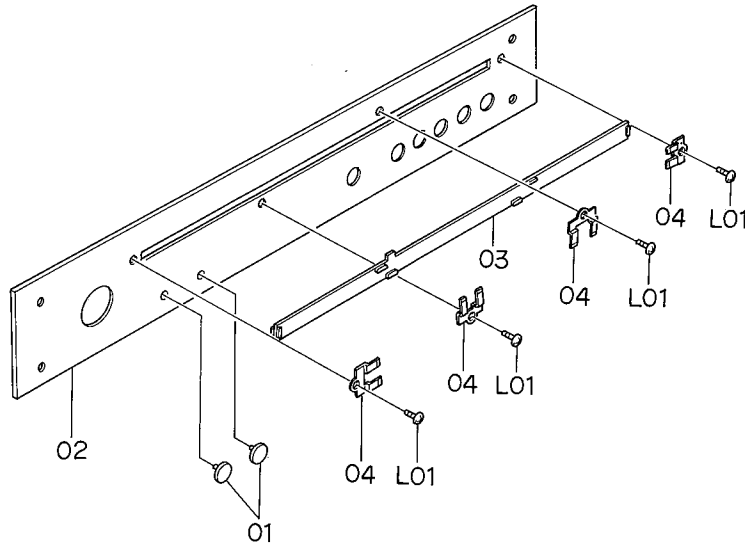

Fig. 7.3

Schematic Ref. No.	Part No.	Description	Q'ty	Schematic Ref. No.	Part No.	Description	Q'ty
K03	HA03719A	Front Panel Ass'y	1		0B08351A	Cord Bushing	1
01	0H03484B	Indicator Point	2	10	0B08325A	Cord Bushing	1
02	0H03533C	Front Panel	1		0B08350A	Power Cord	1
03	0H03534B	Acrylic Cover	1		0B08219B	Power Cord	1
04	0H03535A	Acrylic Cover Hold Spring	4		0B08348A	Power Cord	1
L01	0E00770A	ST M2x3 Philips Binding Head (Black)	4		0B08149U	Power Cord	1
				11	0B08093U	Power Cord	1
K03	HA03765A	Front Panel Ass'y (Japan)	1		0B06567A	Power Transformer	1
01	0H03484B	Indicator Point	2	12	0B06568A	Power Transformer	1
02	0H03532B	Front Panel (Japan)	1	13	0J03710A	Power Supply Panel	1
03	0H03534B	Acrylic Cover	1	14	0J03725B	Power Supply Box	1
04	0H03535A	Acrylic Cover Hold Spring	4	15	0J03726A	Power Supply Cover	1
L01	0E00770A	ST M2x3 Philips Binding Head (Black)	4	16	0M03799A	Caution Label G	1
				17	0M03800A	Caution Label (Canada)	1
A01	JA03196A	Power Supply Ass'y 120V (U.S.A.)	1		0M03745A	Fuse Label 610	1
	JA03197A	Power Supply Ass'y 120V (Canada)	1	18	0M03794A	Voltage Seal 100V	1
	JA03198A	Power Supply Ass'y 100V (Japan)	1	19	0M03797A	Voltage Seal 240V	1
	JA03199A	Power Supply Ass'y 240V	1	20	0M03796A	Voltage Seal 220V	1
	JA03200A	Power Supply Ass'y 220V (1)	1		0M03795A	Voltage Seal 120V	1
	JA03201A	Power Supply Ass'y 220V/240V	1	21	0A03154B	Cord Spacer	1
	JA03207A	Power Supply Ass'y 220V (2)	1	22	0C01162B	Bolt Receptacle Plate	2
01	BA03873A	Power Supply P.C.B. Ass'y	1		0B05186A	Insulating Tube 100mm (U.S.A. & Canada)	1
02	0B08349A	Fuse Clip	4			Insulating Tube 100mm	1
03	0B08161U	Fuse 630mA 250V	2	23	0B05185A	Insulating Tube 50mm	1
04	0B07172A	Power Switch	1	24	0B05928A	Metal Film Resistor 3.9M ERQ-50CDG	1
	0B07092A	Power Switch	1	L01	0B08048A	Fuse Holder	1
05	0B08024U	3P Terminal Strip	1	L02	0B08275U	Fuse 125mA T 250V	1
06	0B08270A	3P Terminal Insulator	1	L03	0E00157A	Washer 3mm Plastics	6
07	0B08363A	Spark Killer	1	L04	0E00510A	Screw M3x8 Philips Pan Head (2A)	2
	0B08342A	Spark Killer	1	L05	0E00593A	Screw M3x6 Philips Binding Head (Bronze)	6
	0B08240A	Spark Killer	1	L06	0E00606A	Screw M3x6 Philips Pan Head (3A)	3
	0B07096U	Spark Killer	1	L07	0E00738A	Screw M4x6 Philips Binding Head (Bronze)	2
08	0B08359A	Spark Killer Cover	1	L08	0E00037A	Earth Lug B-5	1
09	0B08037A	Cord Bushing	1		0E00622A	Screw M3x5 Philips Pan Head (2A)	1
					0E00612A	Screw M3x6 Philips Pan Head (2A)	1

7.4. Power Supply Ass'y (A01)

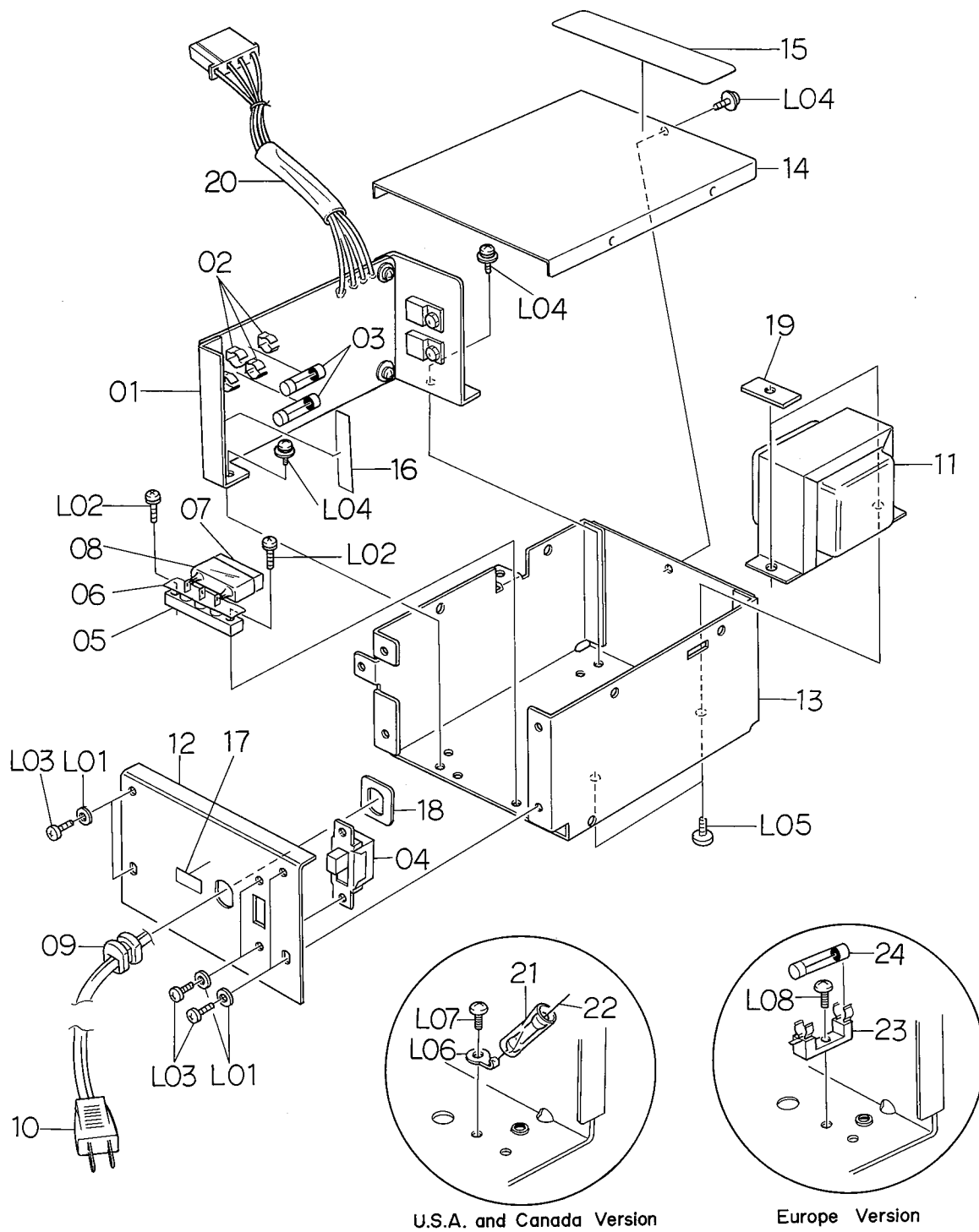

Fig. 7.4

7.5. Main Chassis Ass'y (A03)

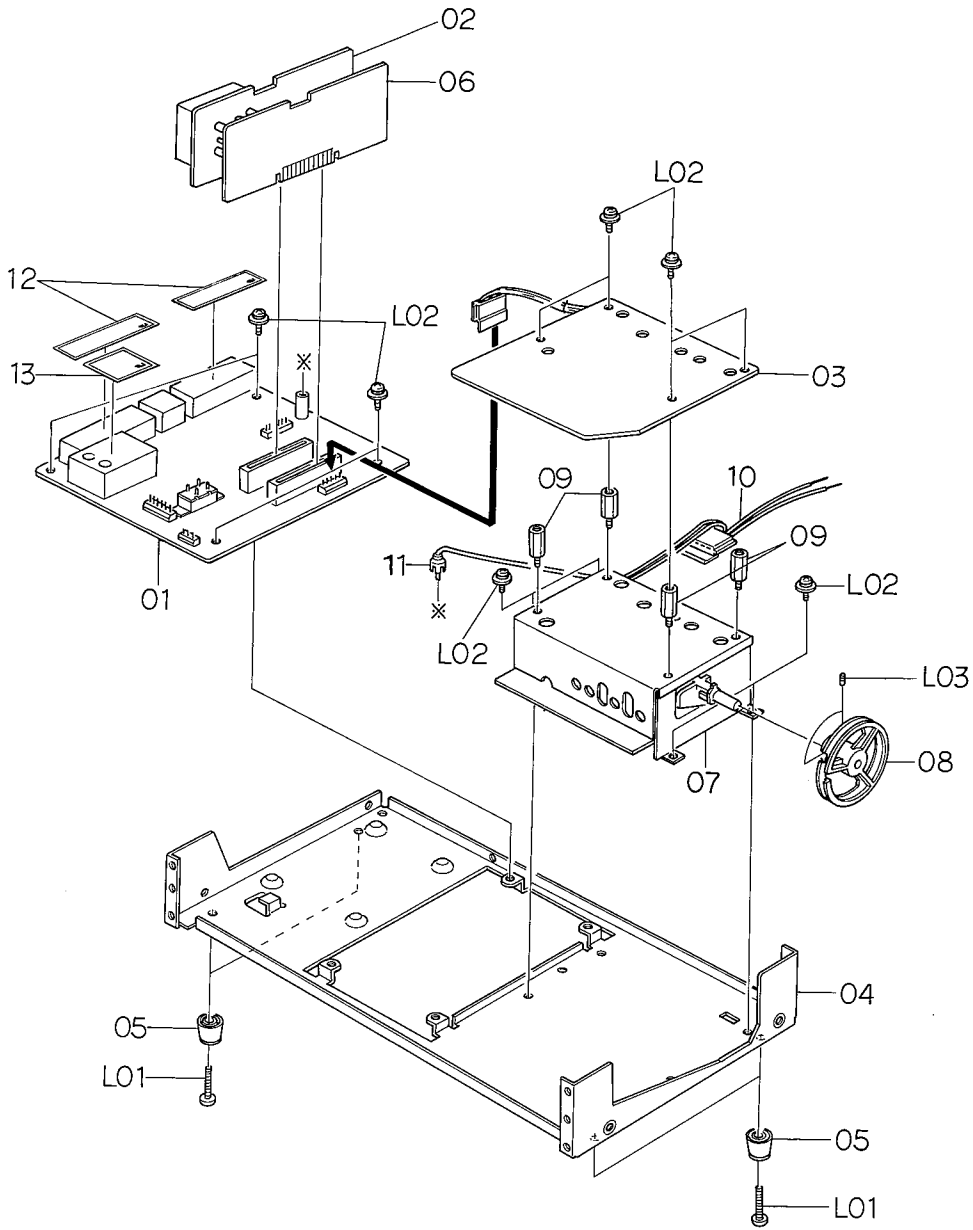

Fig. 7.5

Schematic Ref. No.	Part No.	Description	Q'ty	Schematic Ref. No.	Part No.	Description	Q'ty
A02	JA03186A	Main Chassis Ass'y	1	10	0B08389A	4P-H Connector Ass'y	1
01	BA03869C	Main P.C.B. Ass'y	1	11	0B08383A	Pin Plug Ass'y	1
02	BA03870A	MPX P.C.B. Ass'y	1	12	0M03837A	IF Amp. Block Label	2
03	BA03871D	Indicator H.P.F. P.C.B. Ass'y	1	13	0M03836A	Detector Block Label	1
04	OJ03707A	Main Chassis 430	1	L01	0E00594A	Screw M3x8 Philips Binding Head (Bronze)	4
05	OJ03564A	Foot T-H	4	L02	0E00606A	Screw M3x6 Philips Pan Head (3A)	12
06	BA03879A	Dolby NR P.C.B. Ass'y (Option)	1	L03	0E00755A	Screw M3x6 Hex. Socket Head	2
07	0B08386C	Front-end 430	1				
	0B08387C	Front-end 430 (Japan)	1				
08	OJ03708A	Front-end Pulley 430	1				
09	OJ03727A	Front-end Stud	4				

7.6. Front Chassis Ass'y (A03)

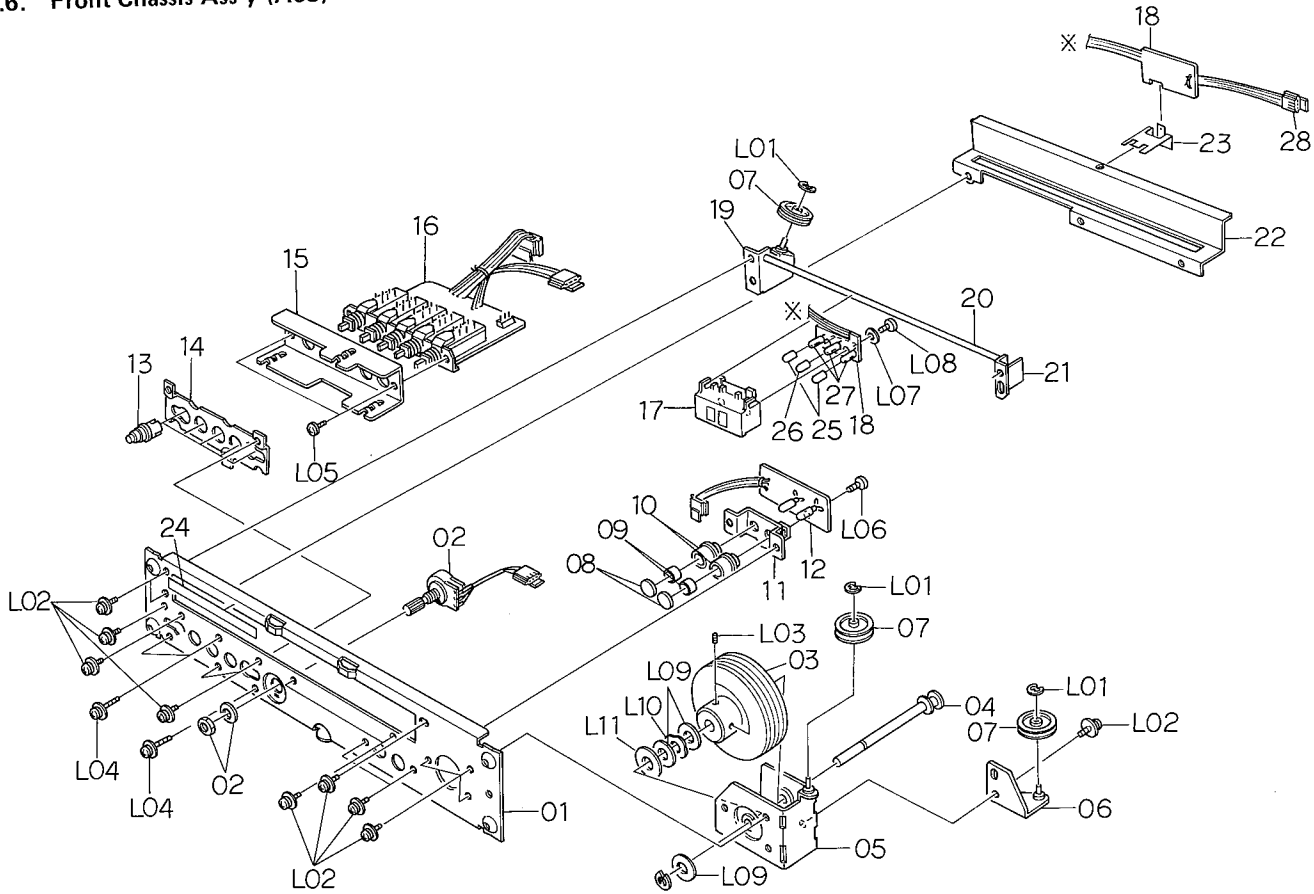

Fig. 7.6

Schematic Ref. No.	Part No.	Description	Q'ty	Schematic Ref. No.	Part No.	Description	Q'ty
A03	JA03187A	Front Chassis Ass'y	1	24	0M03839A	Function Switch Label	1
01	0J03711B	Front Chassis 430	1	25	0H03499A	Filter Cap Green	2
02	BA03876A	Output Volume Ass'y	1	26	0H08389A	Filter Cap Orange	1
03	JA03193A	Flywheel Boss Ass'y	1	27	0B08393A	Indicator lamp 47 12V 60mA	3
04	0J03718A	Tuning Shaft	1	28	0B08391A	4P-H Connector Ass'y 47-2	1
05	0J03717A	Tuning Flange	1	L01	0E00042A	E-Ring 1.5mm	3
06	JA03181A	Pulley Holder 430 Ass'y	1	L02	0E00606A	Screw M3x6 Philips Pan Head (3A)	15
07	0J03611A	Guide Pulley	3	L03	0E00755A	Screw M3x6 Hex. Socket Head	2
08	0J03490A	Orange Filter	2	L04	0E00611A	Screw M3x14 Philips Pan Head (3A)	3
09	0J03598A	Reflector	2	L05	0E00612A	Screw M3x6 Philips Pan Head (2A)	2
10	0J03600D	Lamp Shade B	2	L06	0E00714A	Screw M2.6x6 Philips Binding Head	1
11	0J03723A	Lamp Shade Holder	1	L07	0C05035A	Take-up Thrust Washer	2
12	BA03874A	Stereo Lamp P.C.B. Ass'y	1	L08	0E00771A	ST M2x4 Philips Pan Head	2
13	JA03061A	Push Button Ass'y	1	L09	0J03625B	Shaft Washer	3
14	0J03712A	Switch Plate 430	5	L10	0E00767A	Curve Washer 6mm	1
15	0J03713A	Switch Holder	1	L11	0J03647A	A Buff Washer 6mm	1
16	BA03872A	Switch P.C.B. Ass'y	1				
17	JA03317A	Light Intercepting Box Ass'y	1				
18	BA03875A	Lamp P.C.B. Ass'y	1				
19	JA03192A	Shaft Holder L Ass'y	1				
20	0J03714A	Slide Shaft	1				
21	0J03715A	Shaft Holder R	1				
22	0J03716B	Guide Plate	1				
23	0J03701C	P.C.B. Holder	1				

7.7. Rear Panel Ass'y (A04)

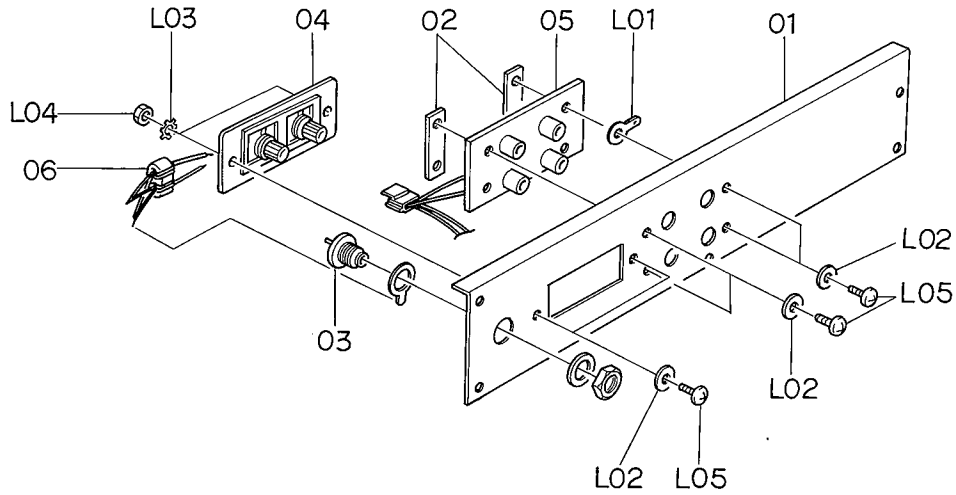
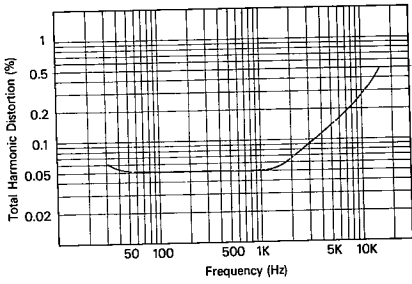

Fig. 7.7

Schematic Ref. No.	Part No.	Description	Q'ty
A04	JA03188A	Rear Panel Ass'y	1
01	0J03709A	Rear Panel 430	1
02	0J03277A	Bolt Receptacle Plate	2
03	0B08320A	Coaxial Connector	1
04	0B08309A	2P Terminal	1
05	0B08390A	4P Pin Jack	1
06	0B06558A	Balun Transformer	1
L01	0E00037A	Earth Lug B-5	1
L02	0E00157A	Washer 3mm Plastics	6
L03	0E00172A	Washer 3mm Toothed Lock	2
L04	0E00507A	Nut Hex. M3	2
L05	0E00594A	Screw M3x8 Philips Binding Head (Bronze)	6

8. PERFORMANCE DATA



Frequency vs. Total Harmonic Distortion (Stereo)
 Modulation: main 45.5%
 sub-carrier 45.5%
 pilot 9%
 Antenna Input: 98 MHz, 65 dBf, 1mV, 300 Ohm

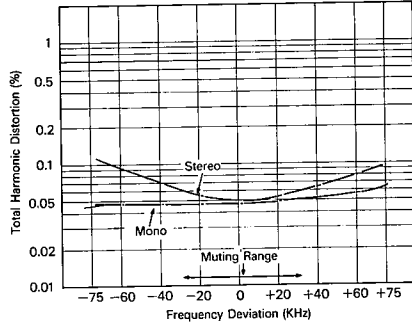

Frequency Deviation vs. Total Harmonic Distortion
 Antenna Input: 98MHz, 65dBf, 1mV, 300 Ohm
 Modulation: main 45.5%
 sub-carrier 45.5%
 pilot 9%
 AFC ON

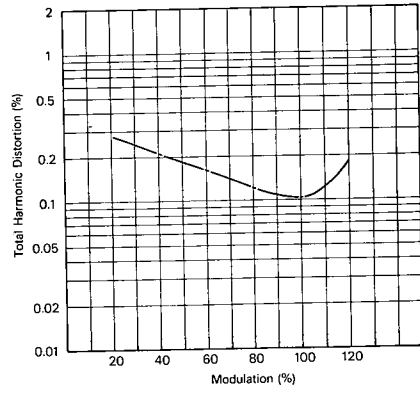

Modulation vs. Total Harmonic Distortion
 Modulation: main 45.5%
 sub-carrier 45.5%
 pilot 9%
 Frequency: 1 KHz
 Antenna Input: 98 MHz, 65 dBf, 1mV, 300 Ohm

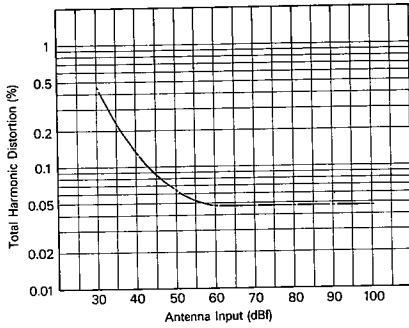

Input vs. Total Harmonic Distortion (Stereo)
 Modulation: main 45.5%
 sub-carrier 45.5%
 pilot 9%
 Frequency: 1 KHz

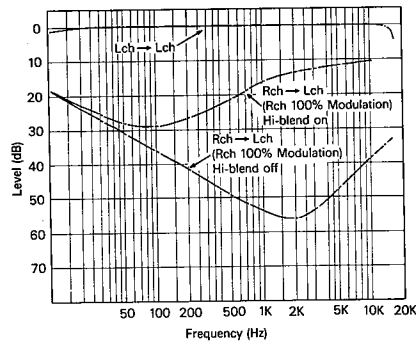

Stereo Separation
 Antenna Input: 98 MHz, 65 dBf, 1mV, 300 Ohm
 IF: Normal

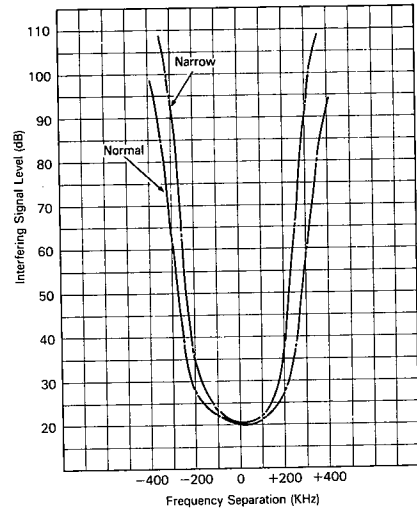

Selectivity
 Impedance: 300 Ohm
 Interfering Signal: 1 KHz 100% Modulation
 Interfering Output Level: -30 dB
 Desired Signal: unmodulated

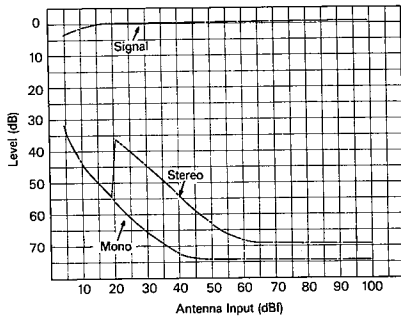

Antenna Input vs. Noise Level
 Frequency: 1 KHz

Fig. 8

9. BLOCK DIAGRAM

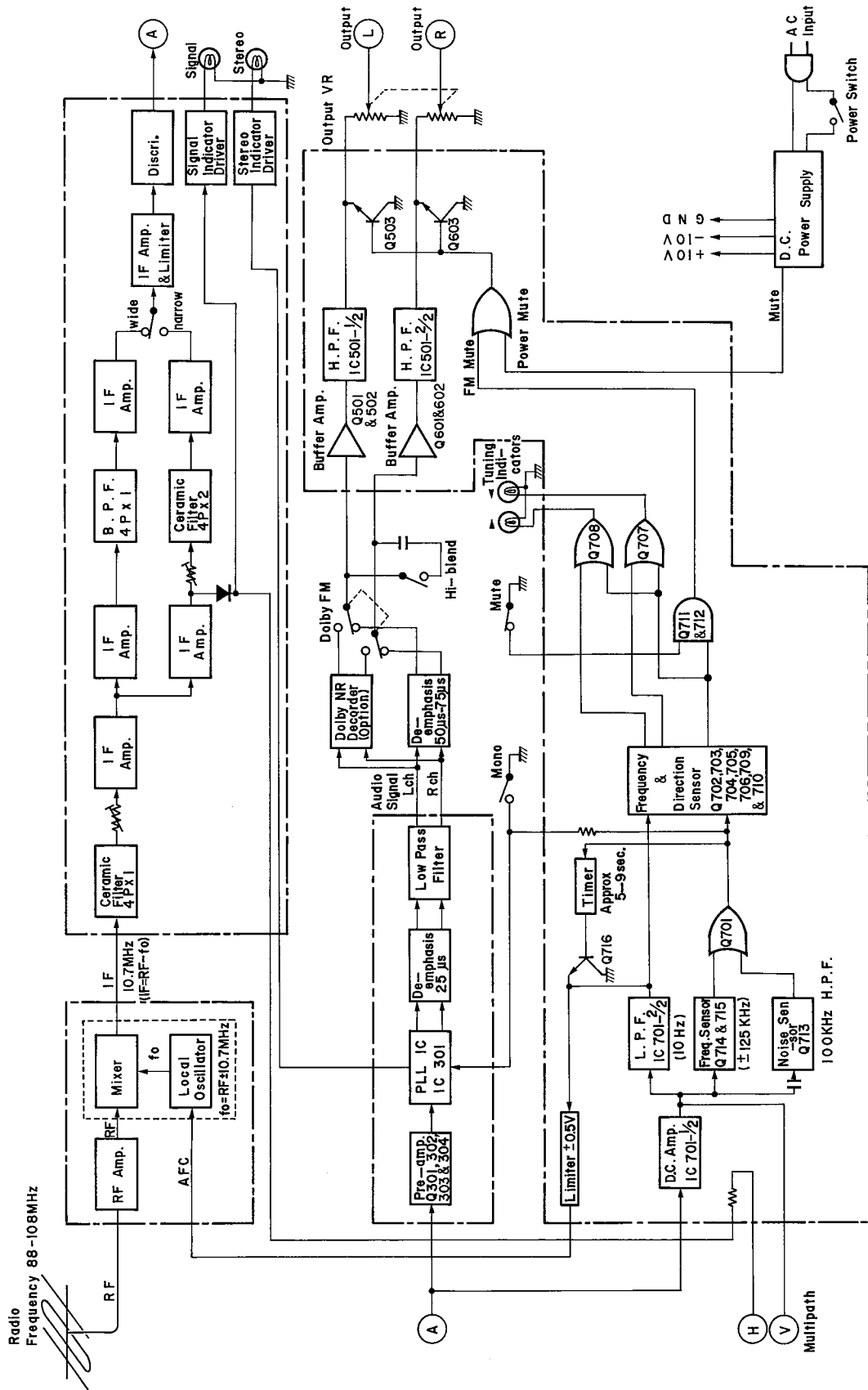

Fig. 9

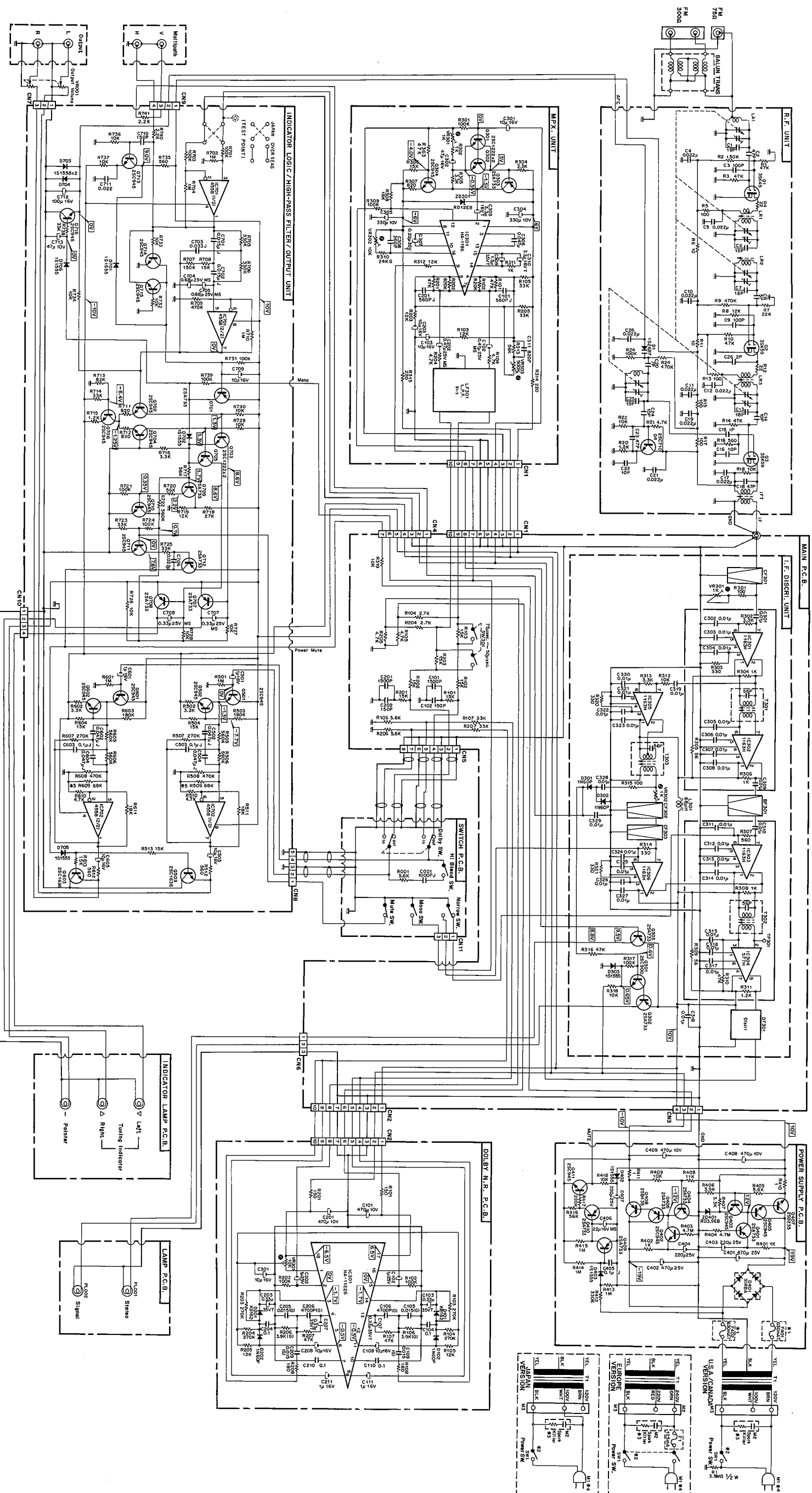

Fig. 11.1

Note: * 1 (Fuse): Only the U.S.A. version does not incorporate.
 * 2 (Power Switch): Depends on each version.
 * 3 (Spark Killer): Depends on each version.
 * 4 (Power Cord): Depends on each version.
 * 5 (R509, R609 of the Indicator H.P.F. P.C.B. Ass'y): Typical Value.

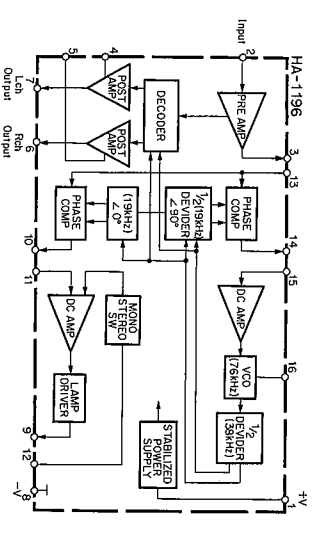

Fig. 11.2 PLL IC

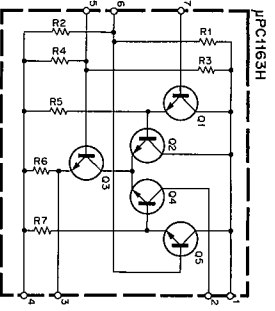

Fig. 11.3 RF IF Amplifier

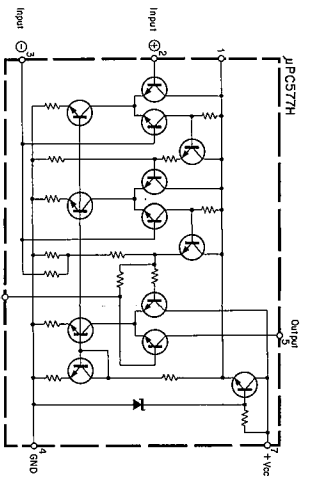

Fig. 11.4 FM-IF Amplifier

12. SPECIFICATIONS

Power Requirements	100 – 120/220 – 240 V AC 50/60 Hz
Power Consumption	11 VA
Frequency Band	88 MHz – 108 MHz
Usable Sensitivity (for 30 dB quieting)	1.8 μ V (300 ohms) 10.5 dBf
Sensitivity (for 50 dB quieting)	mono – 4 μ V (300 ohms) 17.3 dBf stereo – 40 μ V (300 ohms) 37.3 dBf
Signal-to-Noise Ratio (@65 dBf)	mono – better than 70 dB stereo – better than 68 dB
Muting Threshold	7.5 μ V (300 ohms) 23 dBf
Frequency Response	30 – 15,000 Hz + 0.5 – 1.5 dB
Distortion (@65 dBf, 100% modulation)	1 kHz normal mono – less than 0.06% stereo – less than 0.09% narrow mono – less than 0.2% stereo – less than 0.4%
Capture Ratio	normal 1.5 dB narrow 4.0 dB
Alternate Channel Selectivity	normal better than 60 dB narrow better than 90 dB
Stereo Separation	normal 100 Hz – better than 35 dB 1 kHz – better than 50 dB 10 kHz – better than 35 dB narrow 100 Hz – better than 30 dB 1 kHz – better than 30 dB 10 kHz – better than 30 dB
Spurious Response Rejection	better than 100 dB
Image Rejection	better than 100 dB
IF Rejection	better than 100 dB
AM Suppression	better than 60 dB
SCA Rejection	better than 75 dB
Frequency Drift	less than 30 kHz, -10° to 60° C
MPX Filter	-70 dB @19 kHz
Antenna	300 ohms balanced 75 ohms unbalanced
Output Level	500 mV (50% modulation, @ output volume maximum)
Dimensions	15-3/4(W) x 3-5/32(H) x 8-3/4(D) inches 400(W) x 80(H) x 222(D) m/m
Weight	10.8 lb (approx.) 4.9 kg

- Specifications and appearance design are subject to change for further improvement without notice.
- Dolby NR under license from Dolby Laboratories.
- The word "DOLBY NR" and the Double-D-Symbol are trademarks of Dolby Laboratories.

Service Manual

Nakamichi 430

Nakamichi Research Inc.

1-153 Suzukicho, Kodaira, Tokyo

Phone: (0423) 42-1111

Telex: 2832610 (NAKREI J)

Cable: NAKAMICHI KOKUBUNJI

Nakamichi Research (U.S.A.), Inc.

220 Westbury Avenue,

Carle Place, N.Y. 11514

Phone: (516) 333-5440

Telex: 144513 (NAKREI CAPL)

1101 Colorado Avenue,

Santa Monica, Calif. 90401

Phone: (213) 451-5901

Telex: 652429 (NAKREI SNM)