

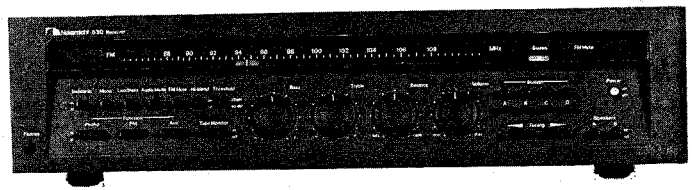

# Service Manual

# Nakamichi 530 Receiver



## CONTENTS

<b>1. General</b> .....	<b>3</b>
<b>2. Principle of Operation</b> .....	<b>4</b>
2. 1. Fundamental Circuits .....	4
2.1.1. C-MOS IC .....	4
(1) Features of C-MOS IC .....	4
(2) Gate Logic .....	5
(3) Gated Flip-Flop .....	5
(4) Compatible C-MOS ICs .....	5
2.1.2. Operational Amplifier IC .....	6
(1) Voltage Follower Circuit .....	6
(2) Amplifier Circuit .....	6
(3) Oscillator (Astable Multivibrator) .....	6
(4) Peak Holding Circuit .....	7
2.1.3. Quadrature Detector .....	7
2. 2. Power Mute Signal .....	8
2. 3. Tuner Section .....	9
2.3.1. FM MPX Stereo Broadcasting Operation .....	9
2.3.2. Operation of Tuner Section .....	10
2.3.3. Tuning System .....	11
(1) Varicon Voltage .....	11
(2) Motor Drive Circuit and Frequency Sensor .....	11
(3) Preset Tuning .....	12
(4) Station Detecting Circuit .....	13
(5) Auto-Tuning .....	13
(6) Tuning Indicator .....	15
(7) FM Mute and Compulsion Mono .....	17
2. 4. Amplifier Section .....	18
2.4.1. Phono Eq. Amplifier .....	18
2.4.2. Subsonic Filter .....	19
2.4.3. Tone Control .....	20
2.4.4. Power Amplifier .....	21
(1) Pre-stage (Voltage Amplifier) .....	21
(2) Output Stage (Power Amplifier) .....	21
(3) Limiter .....	23
2.4.5. Protector Circuit .....	24
<b>3. Removal Procedures</b> .....	<b>25</b>
3. 1. Top Cover .....	25
3. 2. Bottom Cover .....	25
3. 3. Front Panel Ass'y .....	25
3. 4. Front-end Holder Ass'y .....	25
3. 5. Power Transformer .....	25
3. 6. Diode Bridge .....	25
3. 7. Power P.C.B. Ass'y and Heat Sink .....	25
3. 8. Pulley Holder B Ass'y and Pulley Ass'y .....	25
3. 9. Front Chassis Ass'y .....	25
3. 10. Scale Holder Ass'y .....	25
3. 11. Lamp House Cover Ass'y and Lamp P.C.B. Ass'y .....	26
3. 12. Tuning Lamp P.C.B. Ass'y .....	26
3. 13. Indicator P.C.B. Ass'y .....	26
3. 14. Tuning Control Switch Ass'y .....	27
3. 15. Auto-Tuning P.C.B. Ass'y, Preset Volume P.C.B. Ass'y and Preset Switch P.C.B. Ass'y .....	27
3. 16. Power Switch .....	27
3. 17. Main P.C.B. Ass'y and Function P.C.B. Ass'y .....	27
3. 18. Headphone Jack .....	27
3. 19. Rear Panel Ass'y .....	27

3. 20.	12P Jack, Speaker Terminal and Antenna Terminal .....	27
3. 21.	AC Outlet .....	28
3. 22.	Motor Base Ass'y, Front-end Pulley and Front-end .....	28
<b>4.</b>	<b>Adjustments and Measurements .....</b>	<b>29</b>
4. 1.	FM Tuner Section .....	29
4.1.1.	Electrical Adjustments and Measurements .....	29
4.1.2.	Auto-Return Scale Calibration .....	34
4. 2.	Preamplifier Section .....	34
4.2.1.	Signal-to-Noise Ratio Measurement .....	34
	(1) Phono Input/Recording Output .....	34
	(2) Aux. Input/Preamp. Output .....	34
4.2.2.	Distortion Measurement .....	34
	(1) Phono Input/Recording Output .....	34
	(2) Aux. Input/Preamp. Output .....	34
4.2.3.	Phono Eq. Amp. DC Offset Adjustment .....	35
4. 3.	Power Amplifier Section .....	35
4.3.1.	Idling Current Adjustment .....	35
<b>5.</b>	<b>Dial Threading and Scale Calibration .....</b>	<b>36</b>
5. 1.	Dial Threading .....	36
5.1.1.	How to prepare dial thread .....	36
5.1.2.	How to set dial threading .....	36
5. 2.	Scale Calibration .....	36
<b>6.</b>	<b>Mounting Diagrams and Parts List .....</b>	<b>37</b>
6. 1.	Main P.C.B. Ass'y .....	37
6. 2.	Power P.C.B. Ass'y .....	39
6. 3.	Lamp P.C.B. Ass'y .....	39
6. 4.	Preset Switch P.C.B. Ass'y .....	41
6. 5.	Auto-Tuning P.C.B. Ass'y .....	41
6. 6.	Preset Volume P.C.B. Ass'y .....	41
6. 7.	Indicator P.C.B. Ass'y .....	41
6. 8.	Function P.C.B. Ass'y .....	41
<b>7.</b>	<b>Mechanism Ass'y and Parts List .....</b>	<b>42</b>
7. 1.	Synthesis .....	42
7. 2.	Front Panel Ass'y (A01) .....	43
7. 3.	Synthesis Mechanism 530 (A02) .....	44
7. 4.	Front Chassis Ass'y (B01) .....	45
7. 5.	Main Chassis Ass'y (B02) .....	46
7. 6.	Rear Panel Ass'y (B03) .....	47
7. 7.	Tuning Control Switch (C01) .....	48
7. 8.	Scale Holder Ass'y (C02) .....	49
7. 9.	Power Block Ass'y (D01) .....	50
7. 10.	Front-end Holder Ass'y (D02) .....	51
7. 11.	Lamp Case Ass'y (E01) .....	51
7. 12.	Lamp House Cover Ass'y (E02) .....	52
7. 13.	Lamp Base Ass'y (E03) .....	52
7. 14.	Motor Base Ass'y (F01) .....	52
<b>8.</b>	<b>Block Diagrams .....</b>	<b>53</b>
8. 1.	Tuning Section .....	53
8. 2.	Amplifier Section .....	54
<b>9.</b>	<b>Performance Data .....</b>	<b>55</b>
9. 1.	Tuner Section .....	55
9. 2.	Amplifier Section .....	55
<b>10.</b>	<b>Schematic Diagram .....</b>	<b>55</b>
<b>11.</b>	<b>Wiring Diagram .....</b>	<b>57</b>
<b>12.</b>	<b>Specifications .....</b>	<b>58</b>

## 1. GENERAL

Nakamichi 530 control functions are shown below:

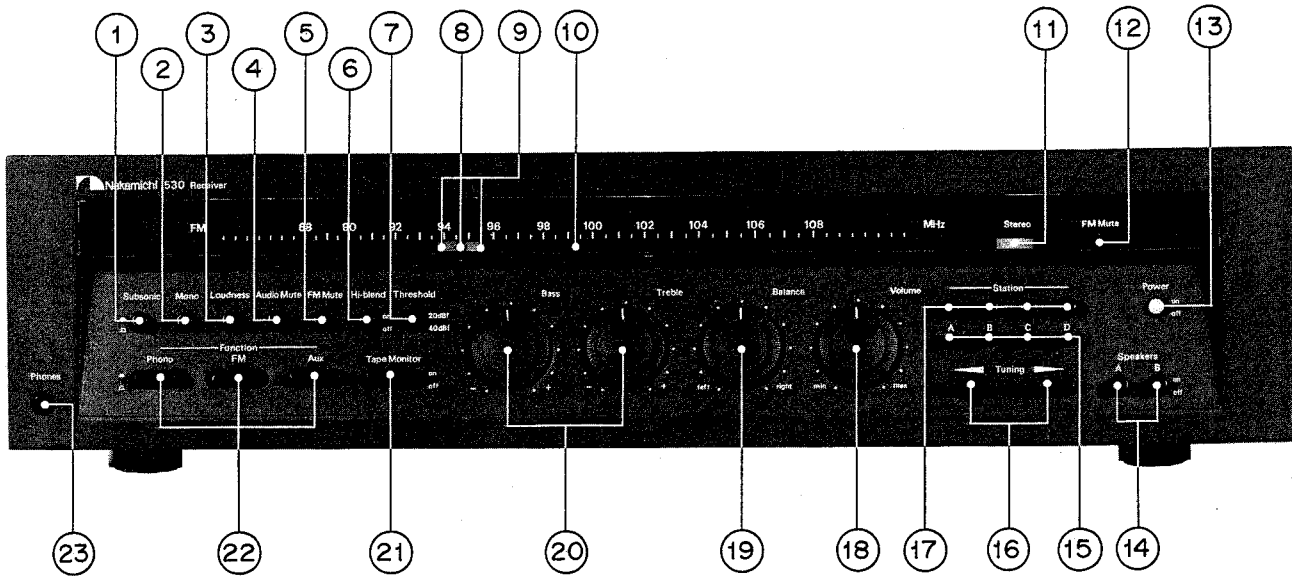

Fig. 1.1 Front View

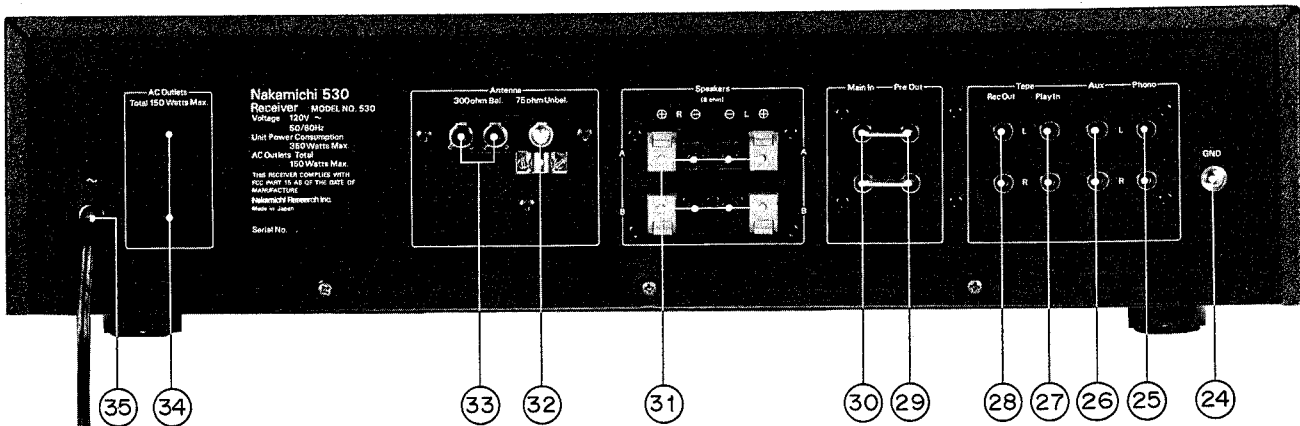

Fig. 1.2 Rear View

- |                                 |   |
|---------------------------------|---|
| 1. Subsonic Filter Switch       | 19. Balance Control                           |
| 2. Mono Switch                  | 20. Tone Controls (Bass, Treble)              |
| 3. Loudness Switch              | 21. Tape Monitor Switch                       |
| 4. Audio Mute Switch            | 22. Function Selector Switches (Aux/FM/Phono) |
| 5. FM Mute Switch               | 23. Headphone Jack                            |
| 6. Hi-Blend Switch              | 24. Ground Terminal                           |
| 7. Threshold Selector Switch    | 25. Phono Input Jacks                         |
| 8. Tuning Pointer               | 26. Auxiliary Input Jacks                     |
| 9. Tuning Indicators            | 27. Tape Playback Input Jacks                 |
| 10. Tuning Scale                | 28. Tape Recording Output Jacks               |
| 11. Stereo Indicator            | 29. Pre-amplifier Output Jacks                |
| 12. FM Muting Indicator         | 30. Main Amplifier Input Jacks                |
| 13. Power Switch                | 31. Speaker Output Terminals (A & B)          |
| 14. Speaker Selector Switches   | 32. 75-ohm Unbalanced Terminals               |
| 15. Station Preset Controls     | 33. 300-ohm Balanced Terminals                |
| 16. Automatic Scanning Switches | 34. AC Outlets                                |
| 17. Station Memory Switches     | 35. AC Power Cord                             |
| 18. Volume Control              |   |

## 2. PRINCIPLE OF OPERATION

### 2.1. Fundamental Circuits

#### 2.1.1. C-MOS IC

##### (1) Features of C-MOS IC

The IC's used in the logic circuit of the N-530 are of the C-MOS (complementary metal oxide semiconductor) type, in which P-channel and N-channel MOS FET's complement each other.

##### (a) Small power consumption

A C-MOS is an inverter, as shown in Fig. 2.1.1.

Whether the input of this inverter is at H or L level, either the P-channel or N-channel MOS FET is OFF, and therefore, current does not pass from VDD to VSS under steady normal state. Consequently, when there is no input, power consumption ( $V_{DD} \times I_{DD}$ ) is nearly zero, except for surface and junction leakage.

When the input signal is switched from H to L, or L to H, however, both P- and N-channel FET's instantly come on, and a current flows either charging or discharging the stray output capacity, so that the power consumption during dynamic operation cannot be said to be zero.

##### (b) A large noise margin

The input-output transmission characteristics of the C-MOS inverter differ from those of bipolar IC's as shown in Fig. 2.1.2. The knee characteristic is sharper, the threshold voltage is almost half of VDD, and the output amplitude is nearly equal to  $V_{DD} - V_{SS}$ .

Since the noise margin of a digital IC is defined as the difference between the minimum value of output amplitude and the required minimum amplitude of the input signal, it is quite natural that the C-MOS circuit, which produces an output amplitude of nearly  $V_{DD} - V_{SS}$  and should be operated by a small input signal, should have a large noise margin.

##### (c) High input impedance

A C-MOS IC has a very high input impedance because it is insulated from the substrate by the oxide film of the gate. Although leakage resistance must be considered in an actual C-MOS IC because diodes are usually used in the direction of reverse bias for protecting input circuit, its impedance is several tens of megohms. The advantage of a high input impedance is that the fan-out of the IC is large, which simplifies the interface. Also, a timer circuit for a longer period of time can be produced. This means that the high input impedance enables the input to be connected with a large resistance, but does not mean to use a capacitor of large capacity.

##### (d) Wide operating voltage range

Fig. 2.1.3 shows input-output transfer characteristics of C-MOS. The general purpose C-MOS family has a wide operating voltage range extending from 3 to 18V, which is much wider than that of TTL and DTL ( $5 \pm 0.25$  V), and HTL ( $15 \pm 1.5$  V). The reason for the C-MOS IC's wide

operating voltage range is that the P-MOS and N-MOS are made symmetrical, and if VDD is varied, the threshold voltage for the circuit is always about half of VDD. In a bipolar IC, the threshold voltage is decided by the forward voltage from the base to the emitter of the transistor (VBE), and is little affected by the source voltage. Therefore, if the source voltage exceeds a certain limit, the output voltage and the threshold voltage will not balance, as a result of which operation will become impossible.

With a C-MOS, the threshold voltage varies according to changes in the source voltage, and stable operation throughout a wide range can be expected. As indicated above, the performance of a C-MOS IC as a digital IC is excellent.

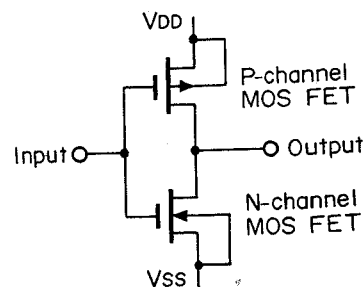

Fig. 2.1.1 C-MOS Inverter

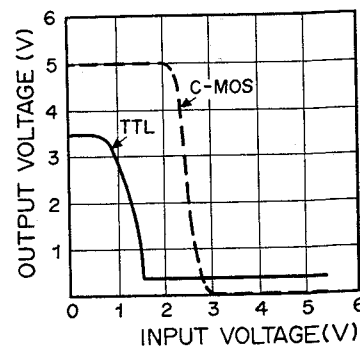

Fig. 2.1.2 Input-Output Transmission Characteristics

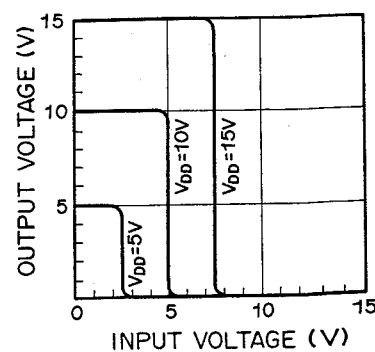

Fig. 2.1.3 Input-Output Transfer Characteristics of C-MOS (The threshold voltage is approximately half of VDD.)

**(2) Gate Logic**

2-input NAND gate is used.

Following show each of logic symbol, truth table, pin assignment, and internal schematic diagram.

The output will be L only if inputs IN1 and IN2 are H's, and the output will be H if IN1 is L or IN2 is L.

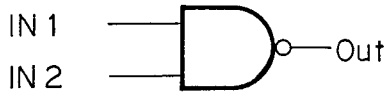

$$\text{Out} = \overline{\text{IN1} \cdot \text{IN2}}$$

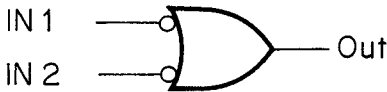

$$\text{Out} = \overline{\overline{\text{IN1}} + \overline{\text{IN2}}}$$

$$\text{Out} = \overline{\overline{\text{IN1}} \cdot \overline{\text{IN2}}} = \text{IN1} + \text{IN2}$$

Fig. 2.1.4

Truth Table 1

IN1	IN2	Out
L	L	H
L	H	H
H	L	H
H	H	L

The construction of the foregoing 2 Logic Symbols is identical and intended to show the use of either AND or OR.

**(3) Gated Filp-Flop**

The two NAND gates can be used to form flip-flop.

The inputs operate as follows:

When both S and R are H's, the flip-flop will remain in its present state, i.e., will not change the state.

If however, the R input goes to L, the NAND gate connected to R will have H output regardless of the other feedback input to the NAND gate, and this will force the flip-flop to the L state (provided the S input is kept H).

Similar reasoning shows that making the S input an L will cause the NAND gate at the S input to have an H output, forcing the flip-flop to the H state (again provided the R input is kept H).

If both inputs R and S are made L's, the next state will depend on which input is returned to H first, and if both are returned to H simultaneously, the resulting state of the filp-flop will be indeterminate. As a result, this is a "forbidden" or "restricted" input combination.

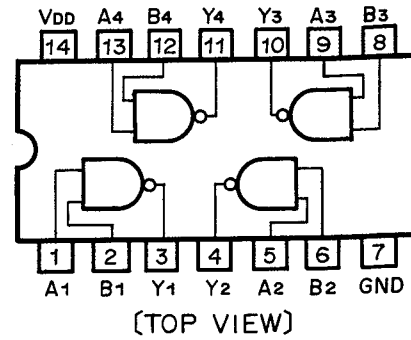

Fig. 2.1.5

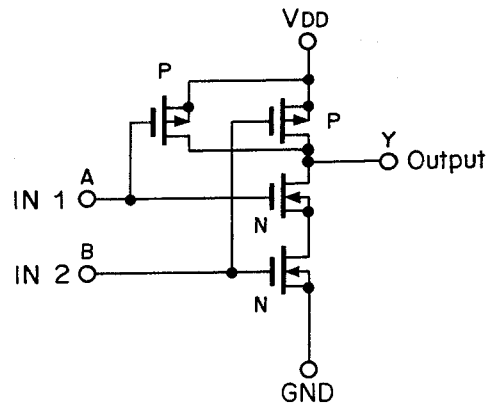

Fig. 2.1.6

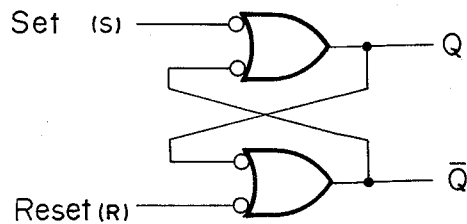

Fig. 2.1.7

Truth Table 2

Set	Reset	Q	Q̄	Remarks
L	L	H	H	*: Maintains the previous state.
L	H	H	L	
H	L	L	H	
H	H	*	*	

**(4) Compatible C-MOS ICs**

IC306:  $\mu$ PD4011C, CD4011A, MC14011A, F34011A, TP4011A, TC4011P

**2.1.2. Operational Amplifier IC**

Most operational amplifier IC's consist of a differential amplifier with a voltage amplification of 70 to 100 dB. High-gain amplifier circuits, oscillators or comparators use operational amplifier IC.

$$(V_{in} - V_{in(-)}) \times A_v = V_{out}$$

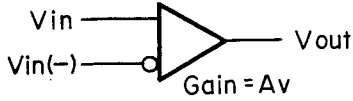

Fig. 2.1.8 Operational Amplifier

**(1) Voltage follower circuit**

This circuit is a special-purpose non-inverting amplifier. It is used for converting impedance when the impedance of the input signal source is too high and the input impedance of the following step is too low for direct connection. The special feature of the voltage follower is high input impedance and low output impedance. Its voltage gain is 1.

$$(V_{in} - V_{out}) \times A_v = V_{out}$$

$$V_{in} = \frac{V_{out}}{A_v} + V_{out} = V_{out} \left(1 + \frac{1}{A_v}\right) \approx V_{out}$$

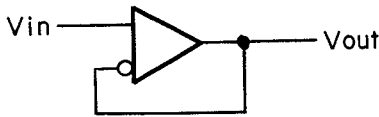

Fig. 2.1.9 Voltage Follower Circuit

**(2) Amplifier circuit**

Two types of amplifier circuits are the inverting amplifier and the non-inverting amplifier. The amplification factor of these circuits is  $\frac{R_1 + R_2}{R_2}$ .

Inverting circuits output signals of phases opposite to those of the input signals.

$$\left(V_{in} - V_{out} \frac{R_2}{R_1 + R_2}\right) \times A_v = V_{out}$$

$$V_{in} = \frac{V_{out}}{A_v} + V_{out} \frac{R_2}{R_1 + R_2}$$

$$= V_{out} \left(\frac{1}{A_v} + \frac{R_2}{R_1 + R_2}\right)$$

$$\approx V_{out} \frac{R_2}{R_1 + R_2} \left(\because \frac{1}{A_v} \approx 0\right)$$

$$V_{out} = V_{in} \frac{R_1 + R_2}{R_2}$$

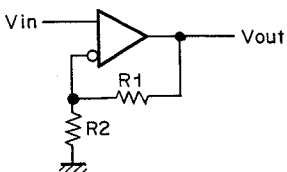

Fig. 2.1.10 Non-inverting

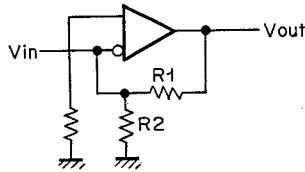

Fig. 2.1.11 Inverting

**(3) Oscillator (Astable Multivibrator)**

The operational amplifier amplifies the difference between non-inverting input and inverting input, and generally its output is amplified up to the source voltage because of the high voltage amplification.

In the circuit shown in Fig. 2.1.12., Vout equals the positive source voltage when the non-inverting input is larger than the inverting input. The voltage of the non-inverting input is  $\frac{R_2}{R_2 + R_3}$  of the positive source

voltage. On the other hand, because C1 is charged by the Vout voltage through R1, the inverting input rises to the positive source voltage. However, when it exceeds the voltage of the non-inverting input, Vout is inverted to the negative source voltage. The voltage of the non-inverting input then is  $\frac{R_2}{R_2 + R_3}$  of the negative source voltage.

When C1 is discharged through R1 and the voltage of the inverting input becomes lower than that of the non-inverting input, Vout is again inverted to the positive source voltage. By repeating these operations, the circuit acts as an astable multivibrator. See Fig. 2.1.13 timing chart.

$$T = 2C_1 R_1 \ln\left(1 + \frac{2R_2}{R_3}\right) \text{ [sec.]}$$

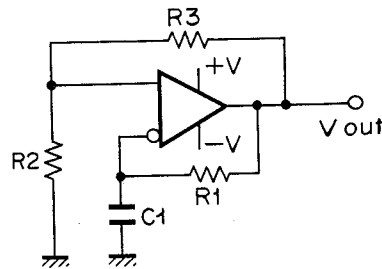

Fig. 2.1.12 Oscillator

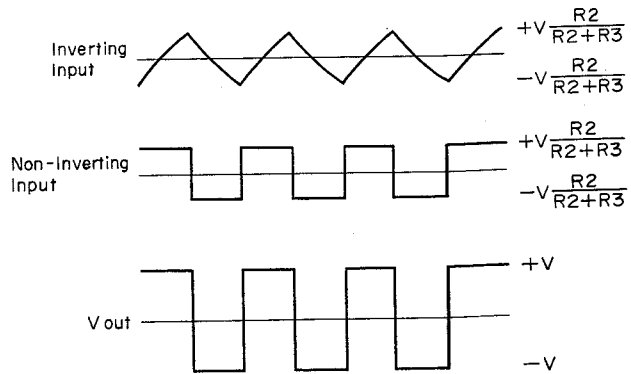

Fig. 2.1.13 Timing Chart

**(4) Peak holding circuit**

Figs. 2.1.14. and 2.1.15. show the peak holding circuit for positive input voltage and its timing chart.

This circuit holds the peak value of the input voltage. When the input signals are pulses, the capacitor C repeatedly charges and discharges to hold the peak value. When no pulse is supplied, C is discharged through R and the output becomes 0 with a certain time constant. It is used in the N-530 in combination with an oscillator for frequency-voltage conversion.

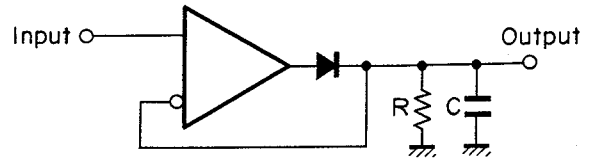

Fig. 2.1.14 Peak Holding Circuit

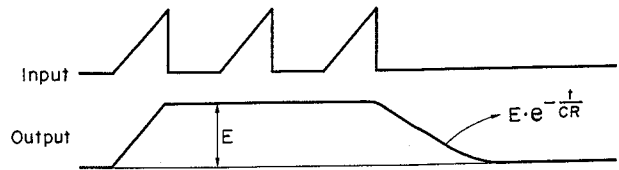

Fig. 2.1.15 Timing Chart

**2.1.3. Quadrature Detector**

Figs. 2.1.16.–2.1.18. show the structure and operation principle of the quadrature detector. It is a phase detector in which a direct signal is supplied to an input terminal of the multiplier, and a signal through a 90° phase shifter

is supplied to another. The pulse width of output  $i_L$  varies according to the phase difference between the direct input  $e_1$  and the input through the phase shifter  $e_2$  and phase detection is made by the increase and decrease of the mean value  $i_{av}$ .

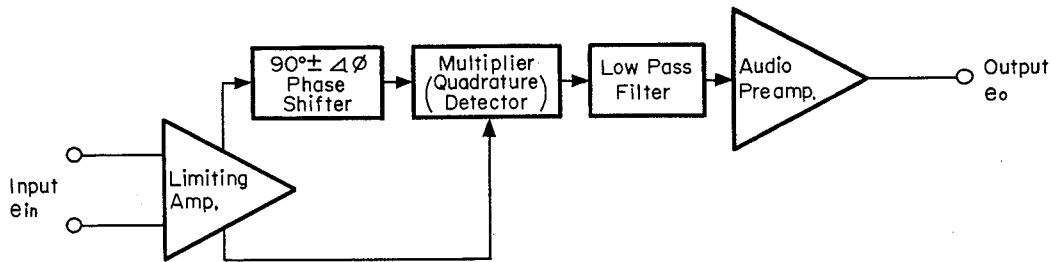

Fig. 2.1.16 Quadrature Detector System Diagram

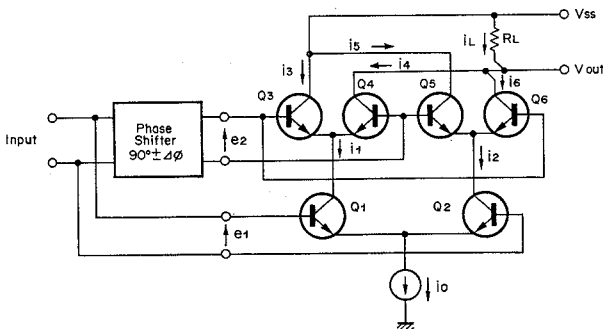

Fig. 2.1.17 Quadrature Detector Circuit

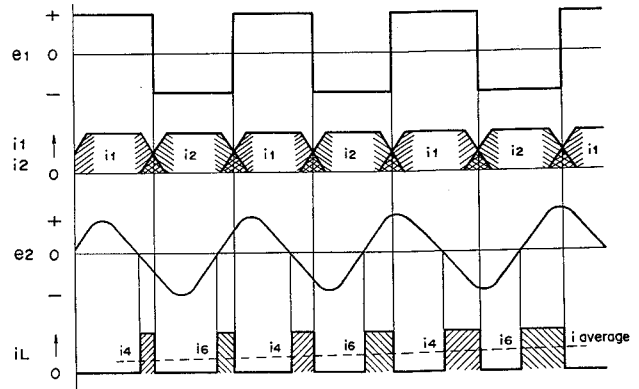

Fig. 2.1.18 Timing Chart



**2.2. Power Mute Signal**

Refer to the timing chart in Fig. 2.2.1. and circuit diagram in Fig. 2.2.2.

**(1) Power ON**

When the Power Switch is pressed to power ON, +12V, ±40V and ±18V Power Source will be supplied.

In the meantime, when Q306 is turned OFF, C309 (33 μF 25 V) will be charged via R314 (1 MΩ), then Q307 will be turned ON approx. 2 seconds later to release the Power Mute Signal. In other words the said Power Mute Signal will bring the N-530 in Mute condition approx. 2 seconds after the Power Switch is pressed ON.

Power Mute = L will enter the Preout Mute Circuit (Q107 and Q207) and Auto Tuning flip-flops of the Main P.C.B., and mutes each output terminal and resets each flip-flop. It is also supplied to the Relay RL301 to turn OFF and opens the supply to Speaker System.

When Power Mute Signal is released, the Relay RL301 becomes turned ON and Speaker System will be connected.

**(2) Power OFF**

When the Power Switch is released to power OFF, +12V, ±40V and ±18V will no longer be supplied, Q306 is turned ON during discharge of C308 (47 μF 25 V) via Q304 and R313 (2.2 MΩ). When Q306 is turned ON, C309 will immediately be discharged via Q306. This way Q307 and Q308 will be turned OFF, Power Mute = H will be supplied to the Main P.C.B.

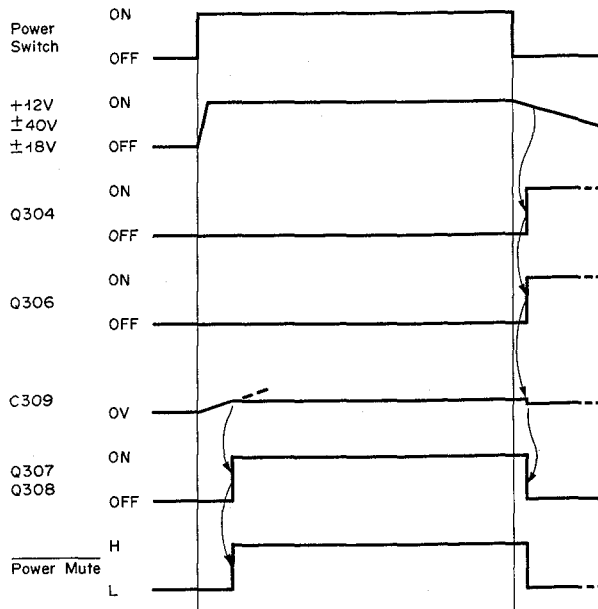

Fig. 2.2.1 Power Mute Timing Chart

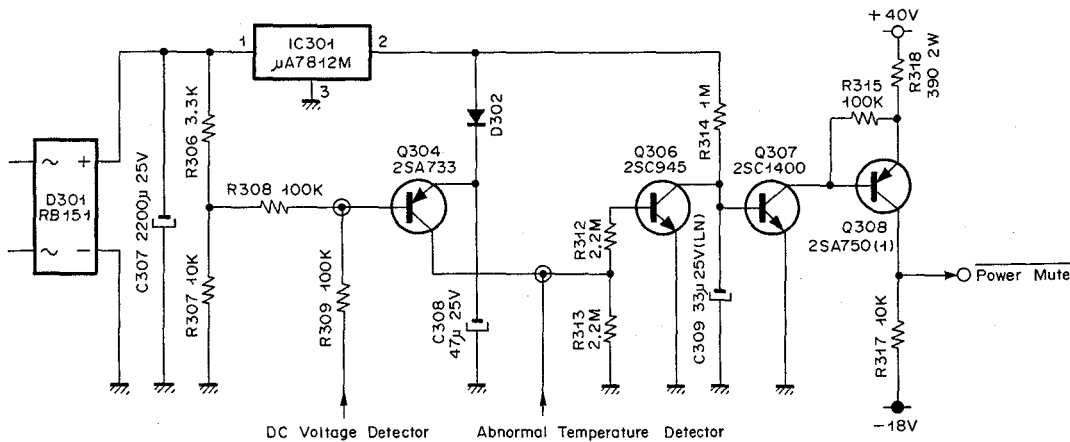

Fig. 2.2.2 Power Mute Generating Circuit

2.3. Tuner Section

2.3.1. FM MPX Stereo Broadcasting Operation

As is generally known, the amplitude of the carrier wave is modulated in AM broadcasting whereas the carrier frequency is modulated in FM broadcasting. Fig. 2.3.1. illustrates these conditions.

FM transmitters and receivers, although considerably more complicated than those for AM broadcasting, permit radio reception with very high fidelity and any difference in technical skill will be noticeably manifested in the performance of the equipment. Compared to AM broadcasting, FM broadcasting has many advantages, such as better frequency response, higher S/N ratio, less interference, less distortion, etc. However, its greatest advantage is the capability for compatible stereo broadcasting. This is achieved by employing a composite signal, as shown in "4" of Fig. 2.3.2. instead of the audio signal shown in Fig. 2.3.1.

Since the composite signals transmitted in ordinary broadcasting have an extremely complex waveform, it is hard to recognize them, even when observed with an oscilloscope. Figure 2.3.2. illustrates an L channel signal of 1900 Hz with no R channel signal.

As shown in "1" of Fig. 2.3.2., this is a stereo signal modulated so as to swing at 38 kHz between the L channel signal and R channel signal.

Therefore, this signal can be separated into L ch/R ch, by a synchronizing signal with the 38 kHz of the stereo signal and a circuit which is conducting at the positive peak and negative peak of this synchronizing signals; the L ch/R ch signals will come out separately.

But, as is shown by the signal waveform "1" in Fig. 2.3.2., since the phase at 38 kHz is reversed between the positive and negative half-cycles of the L ch signal, even with the separation described above, it is not possible to distinguish L ch from R ch.

Under these conditions, it is possible that the L ch/R ch is reversed each time the power switch is turned ON/OFF. Here lies the importance of the pilot signal. That is, when making the 38 kHz signal ("3" in Fig. 2.3.2) by doubling the 19 kHz pilot signal, if the positive and negative peaks of the 19 kHz wave are synchronized with a negative peak at the 38 kHz, L channel can be taken out at the positive peak of the 38 kHz signal and the R channel at the

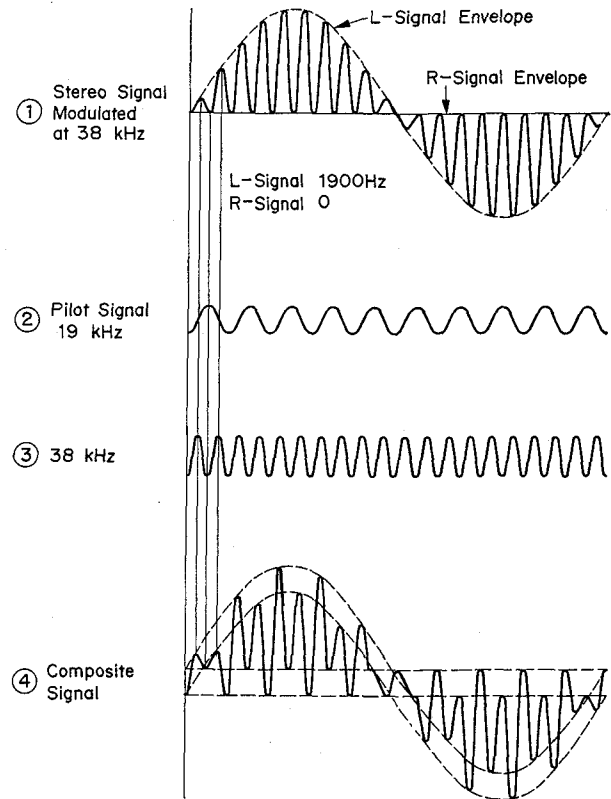

Fig. 2.3.2 MPX Stereo Signal

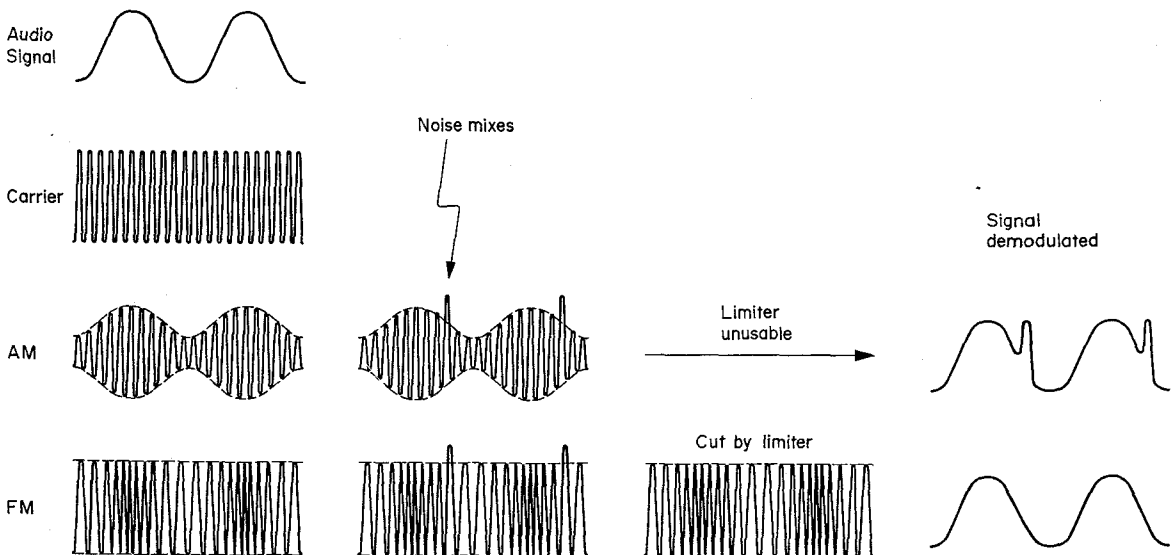

Fig. 2.3.1 AM and FM

negative peak. Thus, MPX stereo signals are broadcast in a waveform such as composite signal "4", obtained by combining the pilot signal "2" with the stereo signal "1" in Fig. 2.3.2.

In order to divide the FM signal into the left and right channels, the MPX stage of an FM tuner must synchronize the multiplex signal with the 19 kHz pilot signal. If this synchronization is not properly performed, stereo separation will be poor.

**2.3.2. Operation of Tuner Section**

Fig. 2.3.3. shows a block diagram of the N-530 tuner section. The input from an antenna which first enters the radio frequency unit (front-end), is amplified in a tuning circuit, and mixed with a local oscillator frequency, and an intermediate frequency (IF 10.7 MHz) is produced. Since the radio Frequency is high and it is impossible to obtain stable amplification and sufficient separation, it is converted to an easy-to-handle 10.7 MHz. Conversion of IF is made to improve these characteristics.

Frequency conversion makes use of the fact that when two different frequencies are mixed and detected, a frequency component equal to the difference between the two frequencies is generated.

Since radio frequencies vary according to the choice of the station, the tuning circuit must be adjustable. However, the use of an intermediate frequency fixed at 10.7 MHz makes it possible to achieve optimum tuning characteristics with a multi-stage tuning circuit (3-stages in the N-530) and sharp separation with two ceramic filters. Also, the function of a limiter to remove extraneous noise, as usual in an intermediate frequency unit, requires a sufficiently high-degree of amplification (130 dB or more in the N-530) to improve limiter characteristics. For this purpose and to prevent instability due to output feedback to the input side, an adequate shield must be carefully arranged. The time required for a signal applied to the input of an intermediate frequency unit to emerge from the output generally varies according to frequency.

In an ordinary broadcasting, since the frequency varies in a range of 10.7 MHz ± 75 kHz, a frequency with a shorter transit time catches up with the preceding signal before emerging as output. This will result in a high frequency. Also, an interval will be opened between a slow signal and the preceding signal which produces a lower frequency. This kind of variation in the transit time occurs mainly in the tuning circuit, resulting in increased distortion. This is called group delay characteristic and one of the important features of an intermediate frequency unit. In the N-530, superior selectivity and group delay characteristics have been realized by employing a 4-element and a 2-element Ceramic Filters, IF Amp. using an IC302 μPC1167C and Quadrature Detector (refer to item 2.1.3).

The composite signal is taken out by demodulating the

FM signal with a Quadrature Detector, IC302 μPC1167C, in the intermediate frequency unit.

Linearity of the discriminator is very important, and must be regulated with adequate care since poor linearity will result in increasing distortion and poor channel separation.

Good Quadrature Detector characteristics are shown in Fig. 2.3.4. by the solid line, where the output voltage varies in a straight line over the ±100 kHz range and voltage is 5 V DC at the center frequency. If, as shown by the dotted line, there is asymmetry above and below, the voltage is not 5 V DC at the center frequency, and the degree of distortion will increase.

The discriminator of the N-530 has a broad linear zone (±200 kHz or more). As the Self-Locked Tuning of the N-530 will operate approximately 7 seconds after the tuning, FM broadcast-receiving can be performed under the distortion free condition at all times.

The discriminator output is applied to the PLL (phase

locked loop) IC, μPC1161C in the MPX unit.

The 38 kHz signal which is synchronous with the 19 kHz involved in the composite signal is produced in MPX unit. This leads to separate the L channel and R channel signals (refer to Fig. 2.3.2). Therefore, in order to achieve good channel separation, the high end and low end of the 38 kHz waveform must be symmetrical and the phase must be precisely aligned. In the N-530, good channel separation has been realized by means of a stabilized synchronizing signal obtained by a PLL IC.

With this, even if an SCA (Subsidiary Communication Authorization) signal is present, no beat interference can occur.

To obtain a good S/N ratio, pre-emphasis is made on the transmitter side and de-emphasis is made on the receiver side. The time constant of 75 μs is mainly employed by the U.S.A. and Canada, and 50 μs in Europe and other countries including Japan.

Although the 19 kHz pilot signal is especially difficult to

remove because of its proximity to the audio signal, the N-530 uses a specially-designed low-pass filter to achieve an attenuation characteristic of 40 dB or more for the 19 kHz signal, while keeping flat frequency response up to 15 kHz.

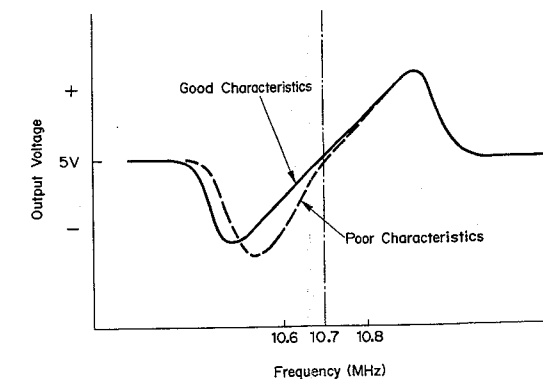

Fig. 2.3.4 Discriminator Characteristics (S-Curve)

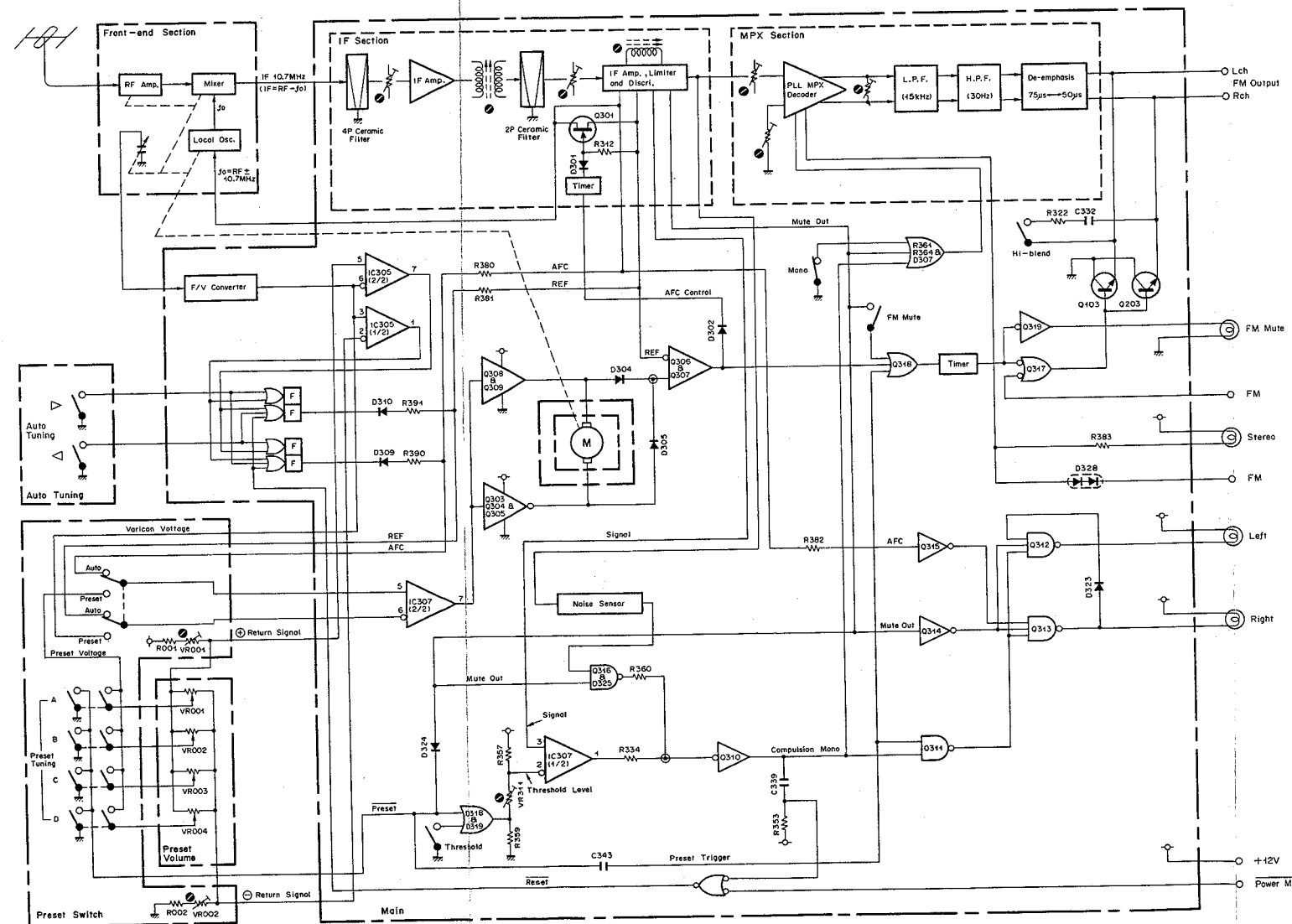

Fig. 2.3.3 FM Tuner System Diagram

### 2.3.3. Tuning System

#### (1) Varicon Voltage

Refer to Figs. 2.3.5. and 2.3.6., circuit diagram and timing chart. Generates the DC voltage (Varicon Voltage) corresponding to the capacity of varicon by means of AM varicon of the Front-end. The DC voltage is in an inverse proportion to the varicon capacity, wherein when capacity is increased, voltage will become decreased. As the varicon capacity corresponds to the tuning frequency, the said Varicon Voltage will become to correspond to the tuning frequency. The variable voltage range of preset tuning, and minimum and maximum range in which the auto-return is activated is also established within this Varicon Voltage range.

IC304-(1/2) of the Main P.C.B. forms an astable multi-vibrator and oscillates square wave of approx. 2.38 kHz. This oscillation output will enter variable integral circuit (becomes variable according to variation of varicon capacity). The integrated signals will enter the plus Peak Hold circuit consisting of IC304-(2/2) and will be converted to DC voltage in inverse proportion to the varicon capacity.

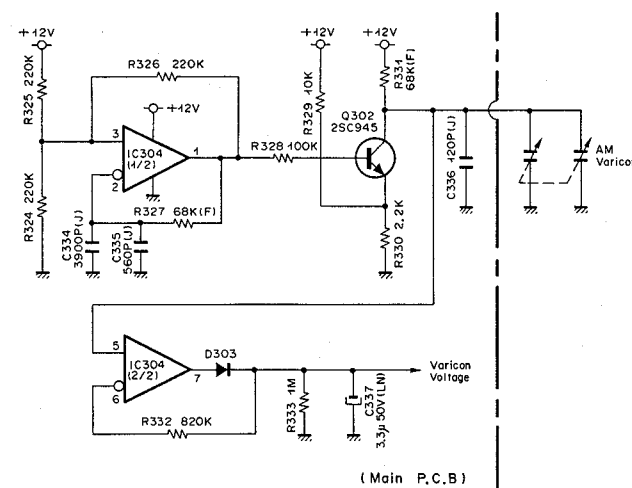

Fig. 2.3.5 Varicon Voltage Generating Circuit

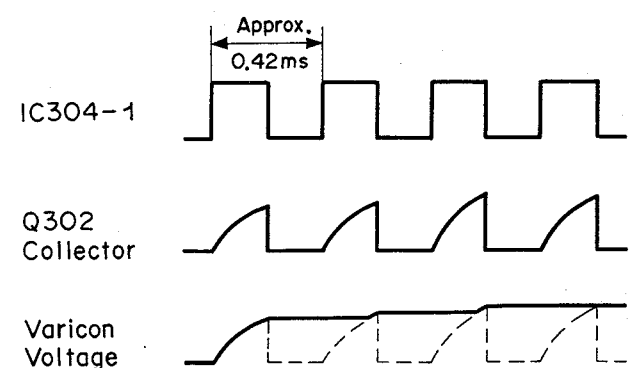

Fig. 2.3.6 Timing Chart

#### (2) Motor Drive Circuit and Frequency Sensor

Refer to Fig. 2.3.7, circuit diagram.

Tuning Motor of the N-530 drives Front-end. Tuning Motor Drive Circuit consists of IC307(2/2), Q303, Q304, Q305, Q308, Q309, etc. IC307(2/2) forms a comparison circuit, and by switching Auto/Preset Switch, comparison of AFC Voltage and REF Voltage in auto-tuning mode, or Varicon Voltage and Preset Voltage in preset mode will be performed. Auto/Preset Switch is one of the 5-Way Switch incorporated in the Preset Switch P.C.B. Ass'y and this switch is interlocked with Automatic Scanning Switches and Station Memory Switches A - D. Tuning Motor will be driven by Q309 and Q305, or Q304 and Q308. Q303 is an inverter to invert the polarity of IC307-7(2/2) output.

When the difference between both IC307(2/2) inputs becomes nil, i.e., both input levels are equal, Tuning Motor will stop.

Frequency Sensor Circuit consists of D304, D305, Q306 and Q307, and D304 will be turned ON when Q309 and Q305 are turned ON and D305 will be turned ON when Q304 and Q308 are turned ON.

D304 and D305 from a wired-OR circuit, and while Tuning Motor is driven, either one diode will be turned ON, thus the output of wired-OR become H. Namely, this circuit detects while motor is driven. When the output voltage of the wired-OR exceeds REF Voltage, Q306 will be turned ON and Q307 will be turned ON. When Tuning Motor is in stop mode, D304 and D305 will be turned OFF, as a result the base voltage of Q306 will become the same voltage as emitter (REF Voltage), accordingly Q306 will be turned OFF and Q307 will also be turned OFF.

The collector voltage of Q307 will become approx. +12 V when Frequency Sensor is activated, but will become GND level when it does not function.

#### (a) Preset Tuning

By pressing Station Memory Switch A, B, C, or D, the said Auto/Preset Switch is released and preset tuning mode is selected. As a result, Preset Voltage is given to IC307-5(2/2) and Varicon Voltage is fed to IC307-6(2/2). Tuning Motor will be driven until the difference between the above inputs to IC307(2/2) becomes nil. When the difference becomes zero, i.e., when Varicon Voltage becomes equal to Preset Voltage, Tuning Motor will stop its rotation and stay at that station.

From this condition, when you turn Station Preset Control manually, a difference of the input levels will occur as the voltage at IC307-5(2/2) changes. As a result, Tuning Motor starts rotation and then stops at the station where the difference of the input levels becomes zero.

#### (b) Auto-tuning

Auto/Preset Switch is changed to auto-tuning side by pressing Automatic Scanning Switch Left or Right, therefore, REF Voltage is given to IC307-5(2/2) and AFC

Voltage is fed to IC307-6(2/2).

Meanwhile, when Automatic Scanning Switch Left is pressed, Auto LT Flip-Flop of the Main P.C.B. Ass'y is set, as a result D309 is turned ON and IC307-5(2/2) is grounded through R390, therefore, both input voltages of IC307(2/2) will become imbalanced. As a result, Q308 will be turned ON and Q303 will be turned OFF, and Q304 will be turned ON. Accordingly Tuning Motor will be driven to the direction that the receiving frequency is decreased. When a station is detected, Reset Pulse is generated and Auto LT Flip-Flop is reset and D309 is turned OFF. As a result, REF Voltage and AFC Voltage are applied to IC307(2/2), and when these voltages become equal, Tuning Motor will stop. If no station is found in the left hand frequency band, Tuning Motor will continue driving until it reaches Minus Return Point.

At IC305(1/2), Minus Return Signal and Varicon Voltage are compared, and when Varicon Voltage exceeds Minus Return Signal, Auto LT Flip-Flop is reset and Auto RT Flip-Flop is set. Therefore, Tuning Motor will change its direction and moves to the right hand frequency band, and then stops if a new station is detected. On the other hand, when Automatic Scanning Switch Right is pressed, Auto RT Flip-Flop of the Main P.C.B. Ass'y is set, as a result D310 is turned ON and IC307-6(2/2) is grounded through R391, therefore, both input voltages of IC307(2/2) will become imbalanced. Thus, Q309 will be turned ON and Q303 will be turned ON, and Q305 will be turned ON. Accordingly Tuning Motor will be driven to the direction that the receiving frequency is increased.

When a station is detected, Reset Pulse is generated and Auto RT Flip-Flop is reset and D310 is turned OFF. As a result, REF Voltage and AFC Voltage are applied to IC307(2/2), and when these voltages become equal, Tuning Motor will stop. If no station is found in the right hand frequency band, Tuning Motor will continue driving

until it reaches Plus Return Point. At IC305(2/2), Plus Return Signal and Varicon Voltage are compared, and when Varicon Voltage exceeds Plus Return Signal, Auto RT Flip-Flop is reset and Auto LT Flip-Flop is set. Thus, Tuning Motor will change its direction and moves to the left hand frequency band, and when a new station is detected, Tuning Motor will stop.

#### (c) Frequency Sensor (Detector while Motor Drive) and AFC Control

While Tuning Motor is driving, Frequency Sensor Output (cathode of D304 and D305) will become H. Since this H level is higher than REF Voltage, Q306 and Q307 will be turned ON. On the other hand, when Tuning Motor is in stop mode, D304 and D305 are turned OFF, as a result the base voltage of Q306 becomes the same voltage as emitter (REF Voltage), therefore Q306 and Q307 will be turned OFF. Collector output of Q307 is given to IF section as AFC Control Signal and controls ON/OFF of AFC function. When Q307 is turned ON, D302 is turned ON and +12 V is applied to AFC Control Circuit. As a result, D301 is turned OFF and Q301 is turned ON, therefore AFC function is not activated as AFC Voltage and REF Voltage become equal.

On the other hand, when Q307 is turned OFF, D302 is turned OFF, and then D301 is turned ON when C320 finished discharge. As a result, Q301 is turned OFF and the shorting between AFC Voltage and REF Voltage through Q301 is released, thus AFC is activated.

Further, when Q307 is turned ON, Q318 is turned ON, and Q319 and Q317 are turned ON. As a result, Q319 will illuminate FM Mute Lamp and Q317 will turn ON Q103 and Q203 resulting in muting FM Outputs. When Q307 is turned OFF, Q318 is turned OFF, and after discharge of C340 is finished, Q319 and Q317 will be turned OFF. Accordingly, in this condition, FM Mute Lamp will go out and mute of FM Outputs will be released.

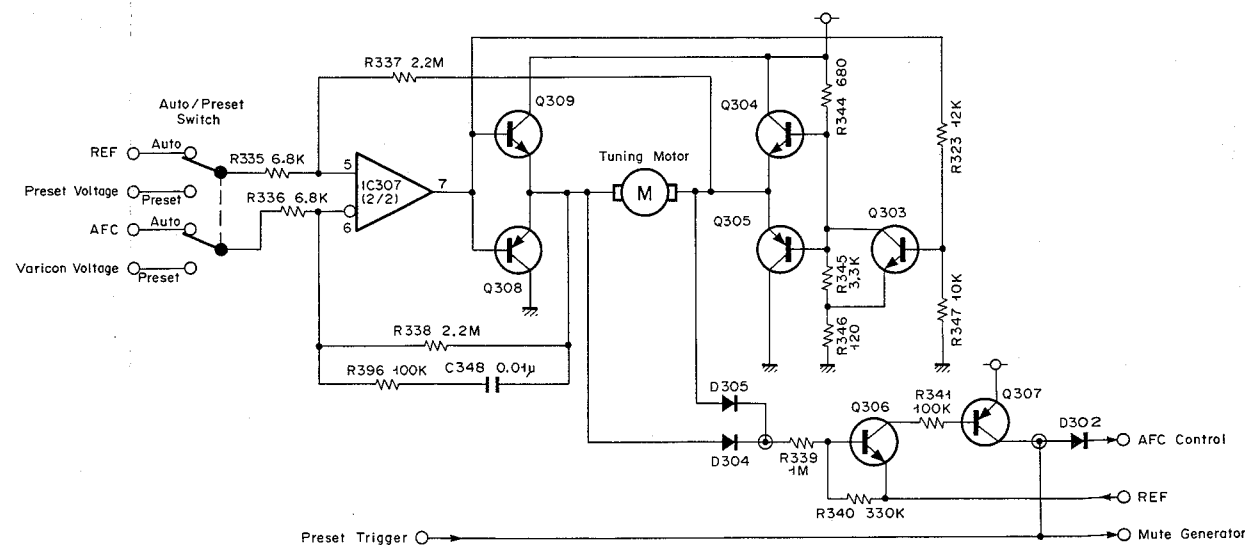

Fig. 2.3.7 Motor Drive Circuit and Frequency Sensor Circuit

**(3) Preset Tuning**

Fig. 2.3.8 shows the range of preset variable voltage while preset tuning, and the voltage of Plus Return Signal and Minus Return Signal for the auto-return while auto-tuning. Fig. 2.3.9 shows its circuit diagram.

Press-command either A, B, C, or D of the Station Memory Sensors will automatically select the preset station.

The N-530 incorporates Auto/Preset Switch. This switch is interlocked with Automatic Scanning Switches and Station Memory Switches A – D, and it will select auto-tuning mode if Automatic Scanning Switch is pressed, and preset tuning mode if Station Memory Switch is pressed. This switch will not change its state unless other tuning mode is commanded.

When Station Memory Switch A is pressed, while in auto-tuning mode, Auto/Preset Switch will be released and preset tuning mode will be selected, and at the same time Station A will be selected.

Through Station Memory Switch A, Preset Voltage set by Station Preset Control A and Preset=L Signal are output. Through Auto/Preset Switch, both Preset Voltage and Varicon Voltage are applied to the Tuning Motor Drive Circuit, and these voltages will be compared by IC307(2/2). IC307(2/2) will detect the difference of levels between the above inputs, Varicon Voltage and Preset Voltage, and if any difference is found, Tuning Motor will be driven, and stops when the difference becomes nil. Above state will remain until the other Station Memory Switches (B, C, and D) or Automatic Scanning Switches are pressed. Preset=L Signal indicates while in preset tuning mode. This signal will be fed to Threshold Control Circuit and will turn ON D318, accordingly threshold level will be fixed to 20 dBf. While in auto-tuning mode,

as Preset Signal is H, D318 will be turned OFF, therefore, either 20 dBf or 40 dBf threshold level can be selected with Threshold Switch.

Preset Signal is converted to Preset Trigger Signal through C343, and while Preset Trigger Signal is H, FM Mute will be activated.

As referred to in Fig. 2.3.15, Preset Trigger Signal is usually at ground level, but at the moment when Station Memory Switch is pressed, minus differential pulse is generated first, then the level is kept H but it will return to the ground level again when Tuning Motor stops. This Preset Trigger Signal is given to Q311 through R362, and while Preset Trigger Signal is H, Tuning Indicators will go out.

After Preset Tuning is made, if Station Preset Control A is manually turned, the balance between the IC307(2/2) inputs will become unequal as the IC307-5(2/2) input level is changed. The Motor will, therefore, drive along the rotation of the Station Preset Control A so that the difference between the said inputs will become nil.

Manual operation with Station Memory Control will be thus performed.

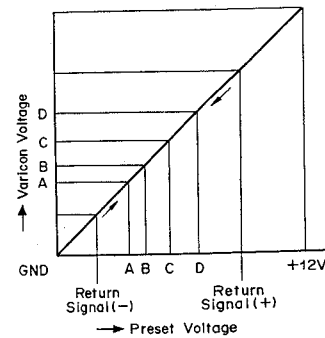

Fig. 2.3.8 Preset Voltage Range

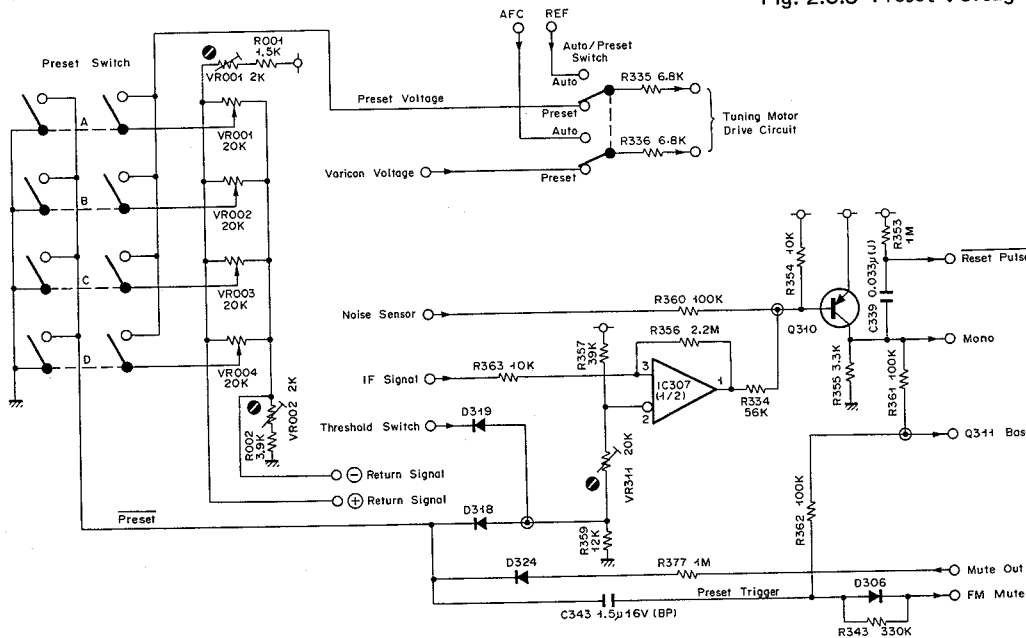

Fig. 2.3.9 Preset Tuning Circuit

#### (4) Station Detecting Circuit

Refer to Fig. 2.3.10, circuit diagram.

Tuning Signal will become H while a station is detected by tuning. IC307-1, the output of IC307(1/2), will become H when IF Signal voltage exceeded the pre-determined threshold level. IF Signal is the output of FM demodulator and it corresponds to the strength of radio field from FM broadcasting stations.

This threshold level is set to either 20 dBf or 40 dBf by means of the Threshold Switch ON/OFF operation while auto-tuning, and while preset tuning it is fixed to 20 dBf as D318 is turned ON.

On the other hand, while a station is already selected, i.e., frequency is tuned within a range of center frequency ( $f_0$ )  $\pm 70$  kHz, Mute Out Signal from the FM demodulator is L, and also Noise Sensor Signal is L as the Noise Sensor Circuit composed of R316, C323, D326, D327 and C324

will not detect inter-station noise.

The said signals are given to Q316. When station is detected, Q316 will be turned OFF, since both Mute Out Signal and Noise Sensor Signal are L. Q316 will be turned ON if Mute Out Signal or Noise Sensor Signal is H. The output of Q316 and the output of IC307(1/2) are given as a condition to control Q310.

When station is detected, Q316 will be turned OFF and the output of IC307(1/2) will become H, as a result Q310 will be turned OFF.

At the moment when station is detected, i.e., when Q310 is turned OFF, a differential Reset Pulse=L pulse is generated through C339, therefore, Auto-tuning Flip-Flops LT and RT will be reset. Station will be detected under the condition that Mute Out=L and Noise Sensor Signal=L and IF Signal exceeded the threshold level.

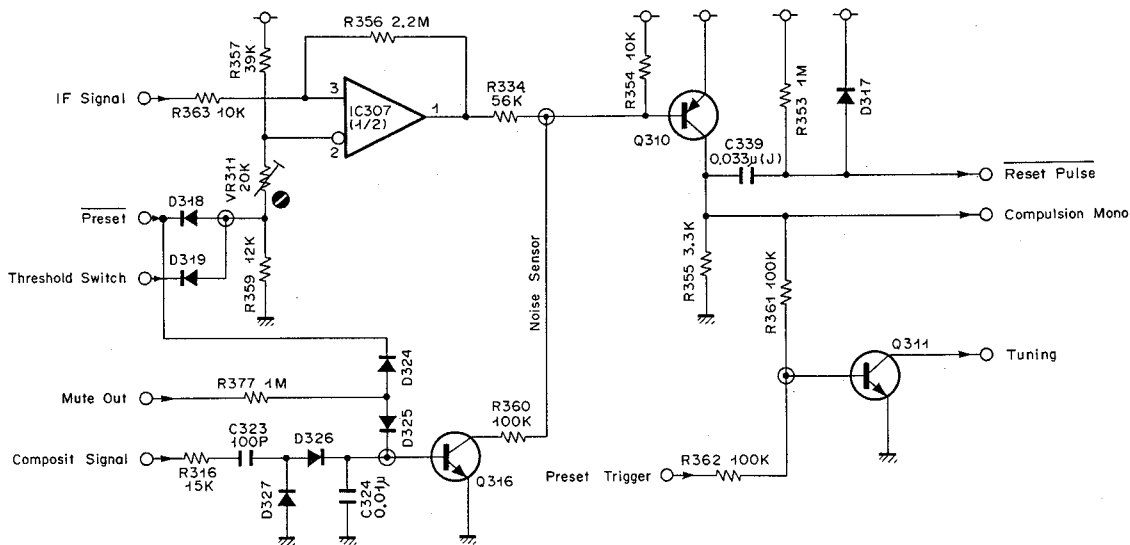

Fig. 2.3.10 Station Detecting Circuit

#### (5) Auto-Tuning

Refer to Fig. 2.3.11, circuit diagram.

##### (a) Auto-Tuning

General flow will be as follows:

- Automatic Scanning Switch Left/Right is pressed momentarily
- Auto LT/RT Flip-Flop (IC306-1,2,3,4,5,6/IC306-8,9,10,11,12,13) is set
- Tuning Motor starts driving until a station is detected
- Station detected (Tuning Signal becomes H and Reset Pulse is generated)
- Auto LT/RT Flip-Flop is reset
- Tuning Motor kept driving (until tuning is completed, i.e., AFC Voltage becomes equal to REF Voltage)
- Auto-tuning completed (Tuning Motor stops)

If the Automatic Scanning Switch LT/RT is kept being pressed, auto-tuning will continue even a station is detected, i.e., Tuning Motor will not stop as Auto LT/RT

Flip-Flop is not reset.

Details along with the general flow would be as follows:

- 1) Automatic Scanning Switch is pressed momentarily  
When Automatic Scanning Switch Left/Right is pressed, Auto/Preset Switch is activated and auto-tuning mode is selected, at the same time Auto LT/RT Flip-Flop is set. Auto RT Flip-Flop will be reset when Automatic Scanning Switch Left is pressed, and Auto LT Flip-Flop will be reset when Automatic Scanning Switch Right is pressed. When Auto LT Flip-Flop or Auto RT Flip-Flop is set, D309 or D310 will be turned ON respectively, as a result AFC Voltage or REF Voltage is grounded through R390 or R391 respectively, therefore, the balance between the both inputs (AFC and REF) of the Tuning Motor Drive Circuit will be lost.

When AFC Voltage is grounded through R390, the output of IC307(2/2) in the Tuning Motor Drive Circuit becomes plus voltage, as a result Q309 is turned ON, Q303 is

turned ON and Q305 is turned ON. Accordingly, electric current passes Tuning Motor via Q309 and Q305, as a result Tuning Motor starts driving so that the Tuning Pointer will move to the left-hand side on the Dial Scale. On the other hand, when REF Voltage is grounded through R391, the output of IC307(2/2) becomes 0 V, as a result Q308 is turned ON, Q303 is turned OFF and Q304 is turned ON. Accordingly, current passes Tuning Motor via Q304 and Q308, as a result Tuning Motor will rotate to move the Tuning Pointer to the right-hand side.

2) Station detected

While the Tuning Motor is driving as referred to in above 1), when a station is detected as per (4) "Station Detecting Circuit", the base voltage of Q310 turns from L to H, as a result Q310 is turned OFF. When Q310 is turned OFF, a differential L pulse is generated at Reset Pulse Signal through C339, as a result Auto LT and RT Flip-Flops are reset through D316 and D315. Therefore, D309 and D310 are turned OFF, accordingly, only AFC and REF voltages are connected to the inputs of IC307(2/2) in the Tuning Motor Drive Circuit.

In case the difference of input levels to IC307(2/2) becomes nil, i.e., AFC Voltage becomes equal to REF Voltage, Tuning Motor will stop its rotation, thus auto-tuning is now completed.

3) Automatic Scanning Switch pressed continuously

When Automatic Scanning Switch Left or Right is kept being pressed, its activation would be as follows:

When a station is detected while auto-tuning, the base voltage of Q310 becomes L from H. At this time Reset Pulse=L is pulse-likely output to the reset input of Auto LT/RT Flip-Flop. As a result, Auto LT/RT Flip-Flop is

reset momentarily, but it is set again since Automatic Scanning Switch is kept being pressed, thus auto-tuning is continued.

(b) Auto-Return

Auto-return to left end (Minus Return Signal) or right end (Plus Return Signal) will be conducted respectively by VR002 or VR001 in the Preset Switch P.C.B. Ass'y.

In an ordinary case, the stations to be selected exist between these ends.

If Automatic Scanning Switch is further pressed to the direction where there should be no station, Tuning Pointer will reach either left or right end of the Dial Scale. When it reached either right or left end, Tuning Motor will change its direction, therefore the direction of auto-tuning will be automatically reversed and auto-tuning will be continued until a station is detected. When detected, Tuning Motor stops there.

IC305-2 and IC305-5 are provided with Minus Return Signal and Plus Return Signal, each determining left end or right end respectively. When the Varicon Voltage exceeds Minus Return Signal or Plus Return Signal level, IC305-1 or IC305-7 will become L respectively.

Accordingly, if Auto LT Flip-Flop is set, IC305-1 will become L when Varicon Voltage exceeds Minus Return Signal, as a result, Auto LT Flip-Flop is reset and Auto RT Flip-Flop is set simultaneously via D313, thus the auto-tuning direction will be reversed.

On the other hand, if Auto RT Flip-Flop is set, IC305-7 becomes L when Varicon Voltage exceeds Plus Return Signal, as a result Auto RT Flip-Flop is reset and Auto LT Flip-Flop is set simultaneously via D314, thus the auto-tuning direction will be reversed.

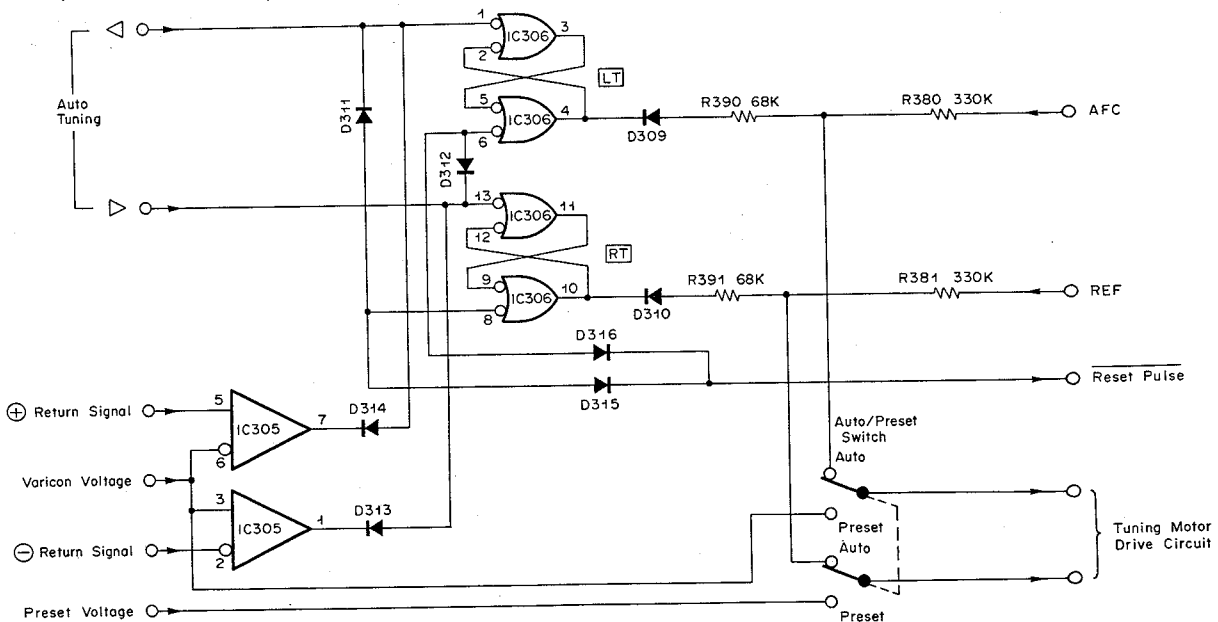

Fig. 2.3.11 Auto-Tuning Circuit

**(6) Tuning Indicator**

Refer to Figs. 2.3.12 – 2.3.16.

While auto-tuning process, both Tuning Lamps will be lit if tuning has met the radio station. While preset tuning by means of the Station Preset Control, however, either Right or Left Lamp will be lit if a station is detected. This way you can further proceed with tuning to locate a tuning point of approx.  $\pm 70$  kHz of the center frequency ( $f_0$ ), when both Lamps will be lit up. Further, in either case of auto-tuning or preset tuning, both Lamps will not illuminate if a station is not detected.

Tuning Pointer Lamp is lit up separately by power ON of the N-530. Mute Out Signal is output from Demodulator IC  $\mu$ PC1167C in the IF section, and its characteristic in a range of  $\pm 70$  kHz of the center frequency ( $f_0$ ) is shown in Fig. 2.3.13.

In each auto-tuning or preset tuning mode, Mute Out Signal will become L when tuning frequency is tuned in a range of  $\pm 70$  kHz of the center frequency ( $f_0$ ) of the station.

This Mute Out Signal is given to the base of Q314, and Q314 is turned ON, as a result plus voltage is applied to the base of Q312 and Q313, accordingly Q312 and Q313 are turned ON and both Tuning Lamps will be lit (in this case Q311 is turned OFF).

Conditions for lightening up both Tuning Lamps are made by AFC Voltage, Tuning Signal, and Mute Out Signal. Tuning Lamps will be lit by Q312 and Q313.

AFC Voltage is directly proportional to the S-Curve, and this voltage becomes 5 V DC when tuning is made at the center frequency of a station. When tuning frequency becomes low with respect to the center frequency, AFC Voltage will become low, and when becomes high, AFC Voltage will become high. From this AFC Voltage, direction sensing of tuning becomes possible.

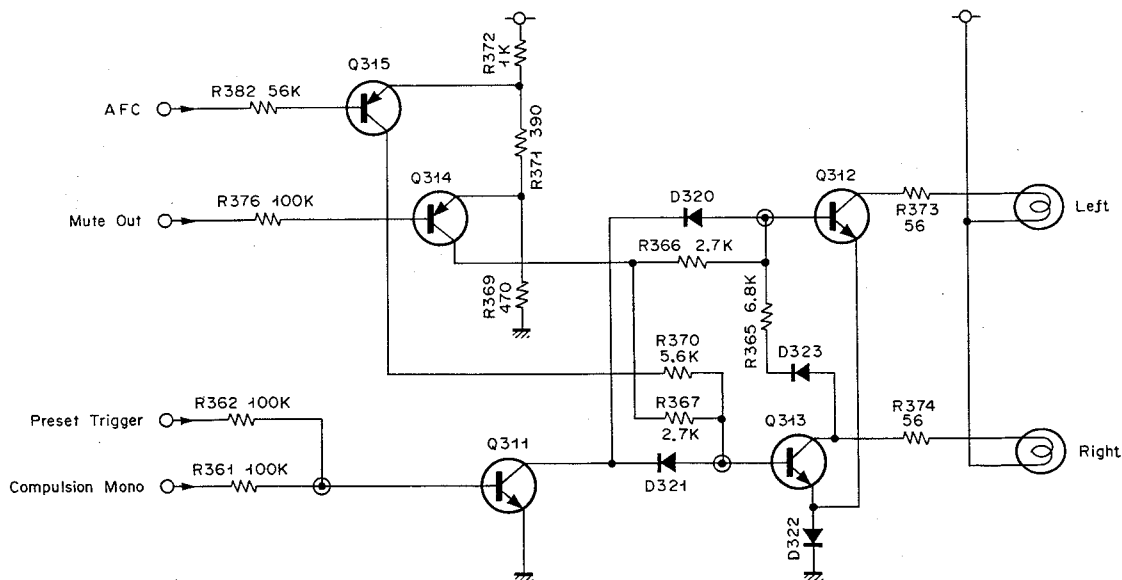

Fig. 2.3.12 Tuning Indicator Control Circuit

Q315 will be turned ON when AFC Voltage becomes lower than 5 V DC, i.e., when frequency becomes low with respect to the center frequency ( $f_0$ ).

**(a) Illumination of Lamp at Tuning by Station Preset Control**

Refer to Fig. 2.3.14, timing chart.

**1) No Station is detected**

When no station is detected, output of IC307(1/2) becomes L as the voltage of IF Signal is smaller than the Threshold Level. Accordingly, Q310 and Q311 are turned ON, as a result D320 and D321 will be turned ON and Q312 and Q313 will be turned OFF, thus the Tuning Lamps will not be lit.

**2) Station is detected but out of Tuning**

Where a station is detected but tuned to the location other than the range of  $\pm 70$  kHz of the center frequency of a station, Mute Out Signal from IC302 will become H, as a result Q314 will be turned OFF. Therefore, Q311 will be turned OFF as Q310 is turned ON, i.e., compulsion Mono=H.

Thus, one of the Tuning Lamps will be lit depending upon ON/OFF of the Direct Sensor Q315.

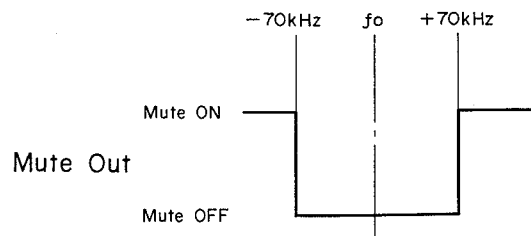

Fig. 2.3.13 Mute Out Signal



Meanwhile, when turned to the frequency 100 kHz lower than the center frequency, Q315 will be turned ON, as a result Q313 will be turned ON, thus Tuning Lamp Right will light up. At this time Q312 will be turned OFF, therefore the Tuning Lamp Left goes out.

On the other hand, when tuned to the frequency 100 kHz higher than the center frequency, Q315 and Q314 will be turned OFF, as a result Q313 will be turned OFF.

Accordingly Q312 will be turned ON as +12 V is applied to the base of Q312 via Tuning Lamp Right, D323 and R365, thus Tuning Indicator Left will be lit up. For the Japan Band, Tuning Lamps Left and Right will be connected oppositely each other. This is resulted from that the Local Oscillator of the FM broadcasting system for Japan Band is located lower side (upper side for Overseas Band) and the polarity of AFC is reversed.

3) Station is detected and tuned within  $\pm 70$  kHz of the center frequency

Where a station is detected and tuned to the location within a range of approx.  $\pm 70$  kHz of the center frequency of a station, Mute Out Signal changes its level from approx. 4 V to approx. 0.6 V.

Therefore, Q314 will be turned ON, and Q312 and Q313 will be turned ON, thus both Tuning Lamps will be lit.

4) Detuned by further turning of Station Preset Control  
When Station Preset Control is further turned, tuning becomes out of the range in the reverse order of the above procedures. When Mute Out Signal becomes approx. 4 V, i.e., tuning frequency becomes out of  $\pm 70$  kHz of the center frequency, one Tuning Lamp will go out but the other still lights ON. When detection of the station becomes impossible by further turning of the Station Preset Control, i.e., when Q311 is turned ON, the other Tuning Lamp also goes out.

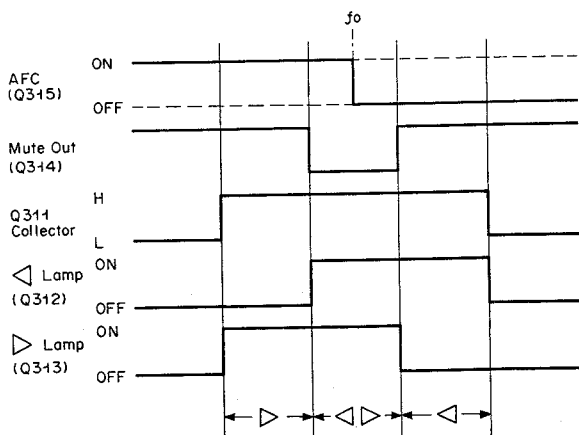

Fig. 2.3.14 Manual Preset Tuning Timing Chart

(b) Preset Tuning by Station Memory Switch A, B, C, or D  
Refer to Fig. 2.3.15, timing chart.

By pressing Switch A, B, C, or D, preset tuning point can be selected automatically. If a broadcasting station is preset, both Tuning Lamps will be lit.

(c) Auto-Tuning

Refer to Fig. 2.3.16, timing chart.

Both Tuning Lamps will illuminate when detection of a station is made by IC307(1/2) and when Mute Out Signal becomes L (tuned within  $\pm 70$  kHz of the center frequency of a station) and when Tuning Motor stops.

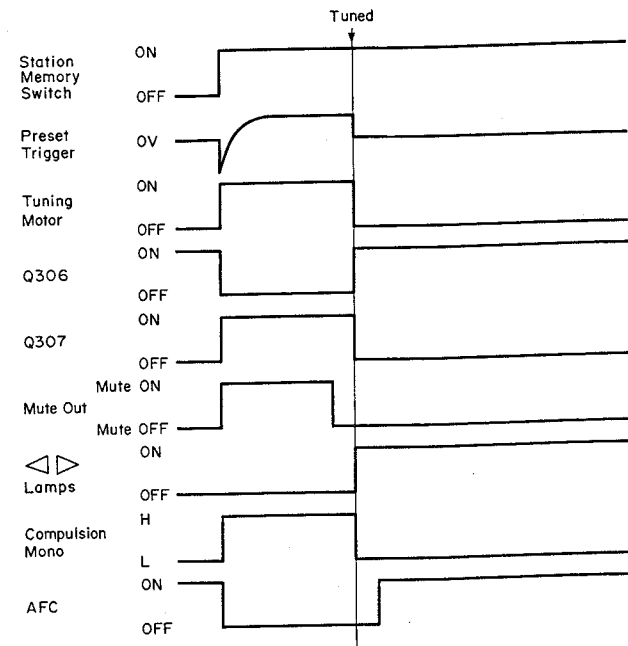

Fig. 2.3.15 Auto-Preset Tuning Timing Chart

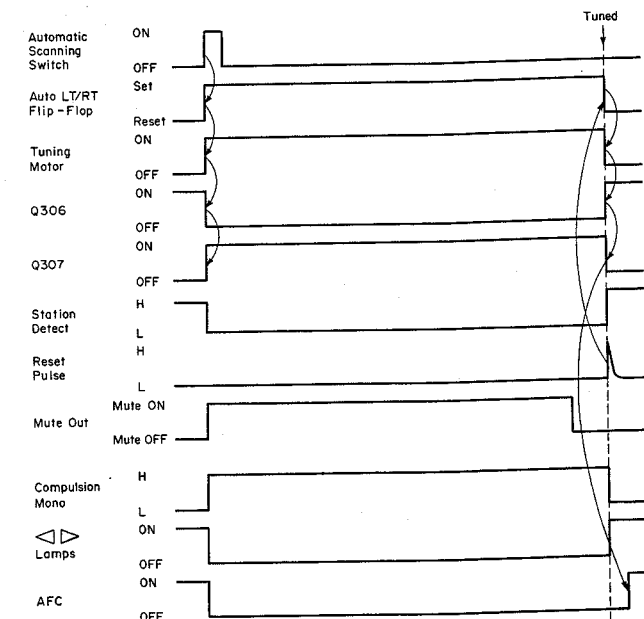

Fig. 2.3.16 Auto-Tuning Timing Chart

### (7) FM Mute and Compulsion Mono

Refer to Fig. 2.3.17, circuit diagram.

FM Output will be muted when Q317 is turned ON.

Q317 will be turned ON when Function Switch selects function other than FM or when Mute Generator (Q318) is activated. Inputs to the Mute Generator consists of Mute Out Signal through FM Mute Switch, Frequency Sensor output and Preset Trigger Signal. Either in auto-tuning or preset tuning mode, the output of the Frequency Sensor will become H while Tuning Motor is driven. As a result, Q318 is turned ON and C340 is discharged, and Q319 will be turned ON, thus FM Mute Lamp will be lit.

At this time Q317 is also turned ON, as a result Q103 and Q203 are turned ON and FM Outputs will be muted.

A differential Preset Trigger=L pulse through C343 is generated at the moment when Station Memory Switch is pressed, then C343 starts discharging and Preset Trigger Signal becomes H, but becomes L when Tuning Motor driving is completed. While Preset Trigger Signal is H, FM Output is muted.

While in auto-tuning mode, Preset Trigger Signal becomes H when Automatic Scanning Switch is pressed, and becomes L when Tuning Motor stops. Through FM Mute Switch, FM Output will be muted by the Mute Out Signal

from IC302.

If preset point is out of tuning, inter-station noise will be output when auto-preset tuning is made. In this case you can mute this inter-station noise by pressing FM Mute Switch. Mute Out Signal will be given to Q318 through FM Mute Switch, as a result FM output will become muted. When tuning is made, Q318 will be turned OFF but Q319 and Q317 will not be turned OFF unless discharge of C340 is completed, thus FM Mute will be kept activated while this period of time.

After completion of C340 discharge, Q319 and Q317 will be turned OFF and FM Mute will be released.

Compulsion Mono Signal will be generated and fed to IC303 either when station detection is not made, or when Mute Out Signal is H, or when Mono Switch is pressed. As a result Mono mode is selected, and Stereo Signal of IC303 will become H, thus the Stereo Lamp will go out. As to Stereo Lamp, when function is set to FM, D328 will become open, as a result Stereo Lamp ON/OFF will be controlled by the Stereo Signal produced by IC303. On the other hand, when function is set to other than FM, D328 will be connected to Mono Switch through FM Switch, as a result Stereo Lamp will be turned ON or OFF by Mono Switch operation.

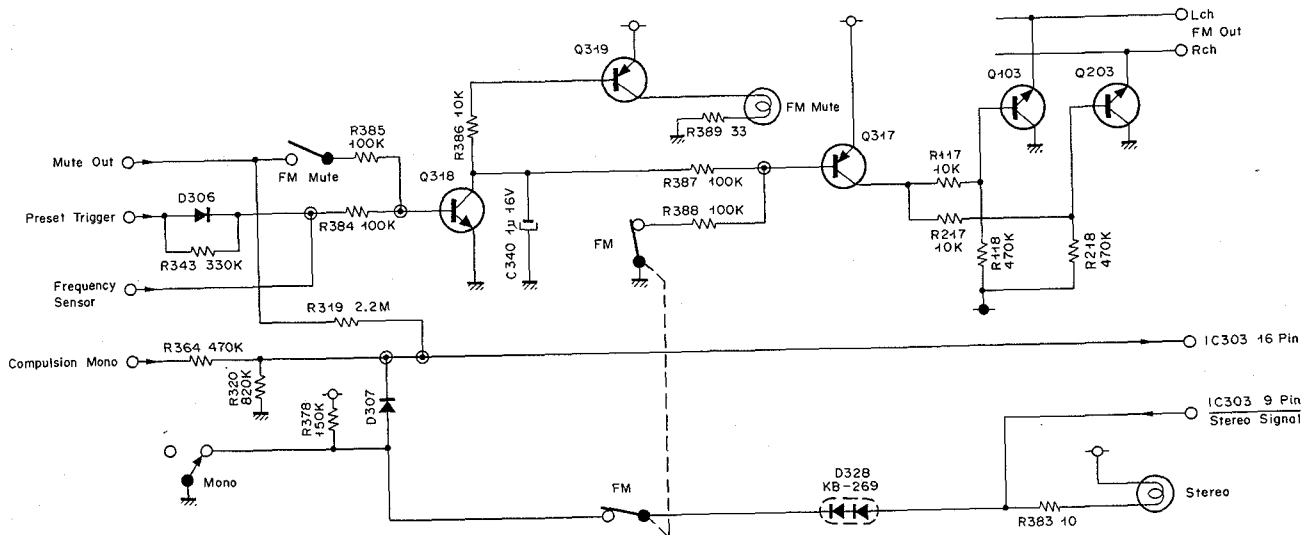

Fig. 2.3.17 FM Mute and Compulsion Mono Circuit

2.4. Amplifier Section

2.4.1. Phono Eq. Amplifier

The Phono Eq. amplifier in the N-530 employs a low-noise transistor combined with a low-noise operational amplifier IC in the first stage in order to obtain a high S/N ratio.

Fig. 2.4.1. shows the circuit configuration, and Fig. 2.4.2. the noise equivalent circuit.

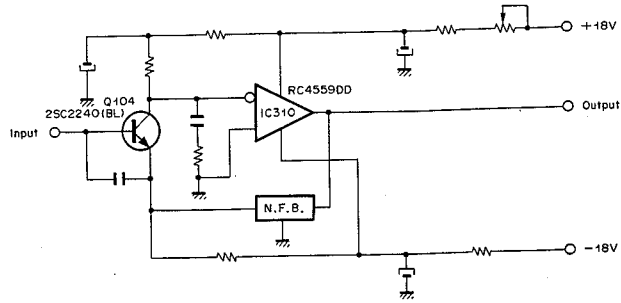

Fig. 2.4.1 Phono Eq. Amp. Circuit

The thermal noise produced by the transistor base input resistor,  $h_{ie}$ , is given by the following equation:

$$E_n = \sqrt{4KT h_{ie} B}$$

- where, K: Boltzmann's constant ( $1.38 \times 10^{-23}$ )  
 T: Absolute temperature  
 B: Frequency Band

When a signal source is connected here, its impedance,  $R_s$ , is connected in series with the  $h_{ie}$ . The thermal noise produced by the total input resistance,  $R$ , is given by the following equation:

$$V_n = \sqrt{4KTRB}$$

where,  $R: h_{ie} + R_s$

As shown in Fig. 2.4.2. (a model of a transistor showing the noise components), the signal source impedance  $R_s$  is connected in series with the transistor base input resistance,  $h_{ie}$ .

Because the signal source impedance,  $R_s$ , is normally larger than  $h_{ie}$ , the thermal noise produced by  $h_{ie}$ ,  $E_n$ , has, in many cases, been ignored.

However, if  $R_s$  is very low, as in an MC cartridge (of the order of several tens or hundreds of ohms), then  $h_{ie}$  will greatly affect the S/N ratio.

Nakamichi's Models N-410, 610, 630 and 730 has been used to reduce  $E_n$  with the triple-transistor system — a circuit with three transistors connected in parallel — to decrease  $h_{ie}$  by a factor of 3, thus  $E_n$  is reduced to  $1/\sqrt{3}$  of the conventional level. However, N-530 employs single transistor, specially designed to reduce  $E_n$ . Furthermore, the N-530 uses a low-noise operational amplifier IC, which, together with above system, reduced the noise level to  $-138$  dB or less.

The characteristics of semiconductors generally differ to some extent. To avoid differences of offset voltage due to differences in semiconductor elements, a semifixed variable resistor is inserted between the positive power source and the positive voltage terminal of Phono Eq. Amplifier to regulate the offset voltage and obtain a low distortion factor.

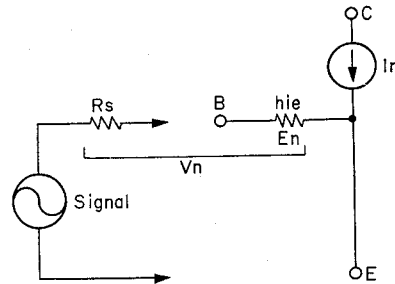

- $I_n$ : Transistor current noise  
 $R_s$ : Signal source impedance  
 $h_{ie}$ : Transistor base input resistance  
 $E_n$ : Thermal noise by  $h_{ie}$   
 $V_n$ : Thermal noise by  $R_s$  and  $h_{ie}$

Fig. 2.4.2

### 2.4.2. Subsonic Filter

The frequency response of ordinary hi-fi phono cartridges covers the subsonic range. The resonance point is near 10 Hz with a peak of 5 to 15 dB. These factors are determined by the mass, compliances and damping resistance of the cartridge and tone arm. Further, near the resonance frequency, the disc record is likely to be eccentric or warped, or the turntable vibrates abnormally. In extreme cases, the resonance frequency increases to the level of disc record playback signals (the worst condition occurs when the vibration caused by the speaker is fed back to the cartridge via air or floor vibration). Usually, the subsonic effect thus produced is not found. Because of inter-modulation distortion, the subsonic effect causes unclear sound from amplifier, speakers or tape decks. It especially affects such systems whose response curves cover lower frequencies (note that, if the woofer moves unsteadily during playback of disc records, the above-mentioned adverse effect can be produced).

The turntable, cartridge and tone arm must be improved to completely eliminate subsonics. However, even improved turntable, etc. could not completely eliminate subsonics. One solution of this problem so far achieved is using commercially available preamplifiers that incorporate subsonic filters. But most of them shows poor attenuation curves of 6 dB/Oct. or 12 dB/Oct., and they can not sufficiently eliminate subsonics. And they have fault to attenuate the low frequency band (near 30 to 40 Hz). The subsonic filter used in the N-530, based on the new active

filtration technology, can realize an ideal filter characteristic.

Fig. 2.4.3. shows the subsonic filter of the N-530. The portion represented by FT is generally known as a twin T filter. Its characteristics are illustrated in Fig. 2.4.4. (1). As shown, the curve of the twin T filter rapidly drops at 20 to 50 Hz, and attenuation at below 5 Hz is rather small. These demerits have been smartly eliminated by the N-530 as follows:

**Improvement 1: Improved Twin T Filter with Boot Strap**  
As shown in Fig. 2.4.3., the output from the twin T filter is amplified by Q105 and taken out from its emitter. This output provides positive feedback to the base of Q105 through C120 and R133. This greatly reduces the level down in the range 20 to 50 Hz. For greater attenuation in the range below 5 Hz, R135 is added to lower the load impedance of the filter and to change the impedance of each element so that the asymmetric curve as shown by Fig. 2.4.4. (2) can be achieved.

**Improvement 2: Addition of CR Filter**  
The curve shown in Fig. 2.4.4. (2) is satisfactory for the subsonic filter except insufficient attenuation at below 5 Hz.

Besides the N-530 uses a CR filter consisting of C122 and R139 to achieve a more ideal subsonic filter curve as shown by Fig. 2.4.4. (4). (In Fig. 2.4.4. (3) shows the CR filter curve and (4) is a combination of curves (2) and (3).)

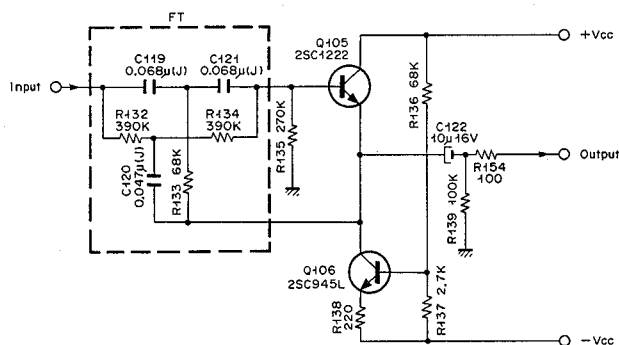

Fig. 2.4.3 Subsonic Filter Circuit

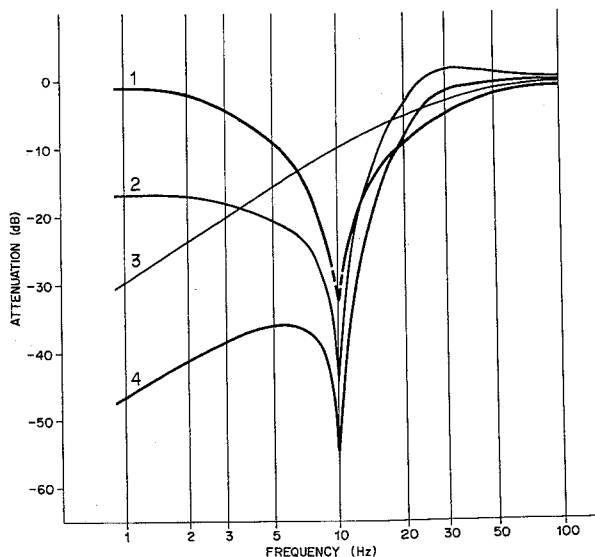

Fig. 2.4.4

**2.4.3. Tone Control**

Refer to Fig. 2.4.5. The tone control section of the N-530 is in the last stage of the pre-amplifier section.

It consists of an audio muting circuit, a tone control circuit, a mono circuit, a loudness circuit, a volume control circuit and a balance control circuit.

In the first stage of the tone control section consists of a voltage amplifier. The gain at this stage is:

$$A = \frac{10K + 1.8K // 47K}{1.8K // 47K} \approx 6.77 \text{ (16.61 dB)}$$

The audio muting circuit is used as a kind of attenuator. When the audio mute switch of the front panel is pressed ON, audio muting circuit is activated, and the gain becomes:

$$A = \frac{100K // 3.3K}{27K + 100K // 3.3K} \approx 0.11 \text{ (-19.5 dB)}$$

Therefore, the audio mute signal is attenuated approximately by 19.5 dB when the audio muting switch is pressed ON.

The tone control circuit is of NF-type tone control circuit, and no attenuation occurs in this circuit. This circuit is designed so as to control bass and treble tones independently without interference.

The loudness circuit is combined with the volume control in the first stage of the tone control section. When the volume control is turned to the left side (approximately -40 dB at 1 kHz), and the loudness switch is pressed ON, 20 Hz and 20 kHz signals are amplified approximately by 14 dB and 6 dB, respectively, when the 1 kHz level is taken as 0 dB.

The output of the tone control circuit is muted by Power Mute signal.

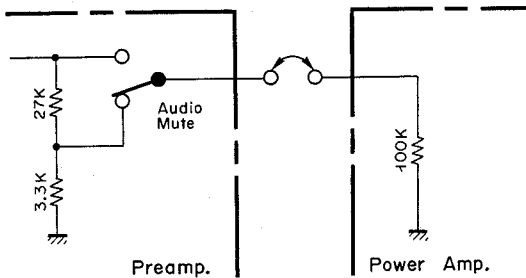

Fig. 2.4.6

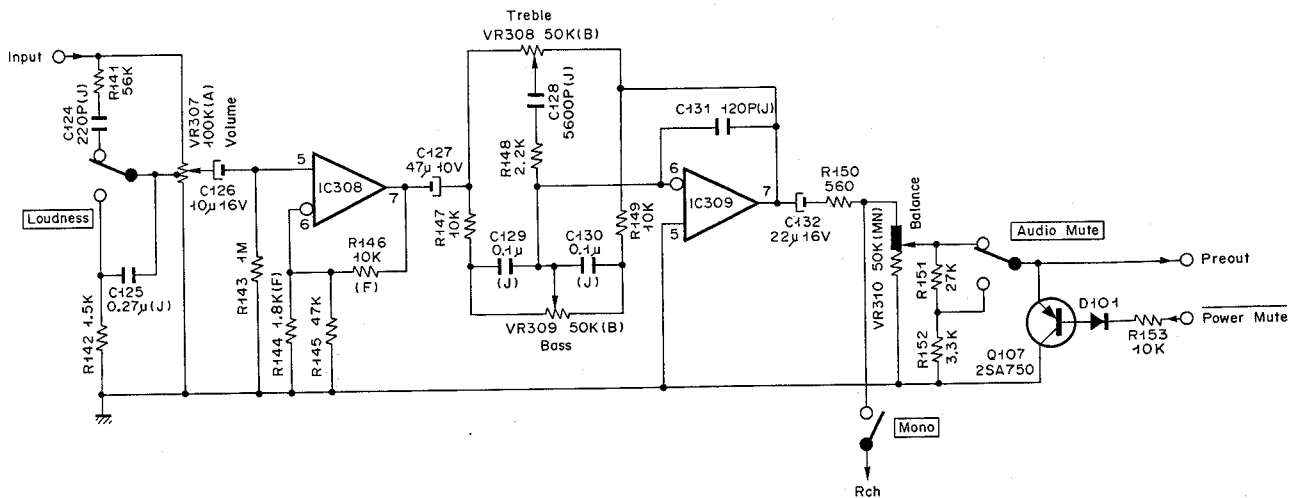

Fig. 2.4.5 Tone Control Circuit

2.4.4. Power Amplifier

(1) Pre-stage (Voltage Amplifier)

Refer to Fig. 2.4.7.

As all the output stage consists of emitter-followers, the voltage gain is approx. 1. Therefore, the gain required for power amplifier and NFB is obtained at the pre-stage. Generally, an increase in the number of transistor stages of an amplifier circuit increases distortion and phase shift. In large current amplification as seen with a power amplifier, a certain extent of distortion cannot be avoided and should be limited through use of NFB. However, excessive NFB is likely to cause unstable amplification as a result of phase shift in the amplifier or differences in loudspeaker impedance. This is one of the drawbacks inherent to an NFB amplifier.

The power amplifier used in the N-530 employs 8 transistors, of which only two serve for voltage amplification and the remaining six are used to provide the former two with the best operating conditions. A gain of approx. 100 dB is obtained through these two transistors to perform power amplification and NFB. The amplifier of this configuration assures stable NFB with low noise and low distortion and with little phase shift.

- Q101, Q107: for voltage amplification
- Q102, Q103: current mirror circuit (the same current at both collectors)
- Q105, Q108: constant-current source

- Q106: for impedance conversion (emitter follower)
- Q104: Q104 and Q101 make up a differential amplifier circuit. Thus, stable NFB is applied through a circuitry using these transistors.
- Q105: determined the high-band characteristic of the voltage amplifier to prevent NFB from becoming unstable because of unbalanced performance of transistors, etc.
- R116: resistor for NFB (signal)
- R119: resistor for NFB (DC)

(2) Output Stage (Power Amplifier)

In the N-530 for making a bias voltage, varistor used in the conventional design of amplifier is replaced with transistor base-emitter so that the N-530 design improves bias stability (against temperature or current changes) with lower distortion.

Especially for a class B push-pull amplifier, distortion cannot be reduced unless the positive and negative signal amplifiers are well balanced. The amplifier in the N-530, however, is best balanced thanks to the vertically and horizontally symmetric configuration as shown in Fig. 2.4.7. This circuit allows distortion of only 0.1% at 1 kHz 55 watts output even without NFB. This degree of distortion is low enough to make the amplifier used as a high-fidelity unit even if it is given no NFB.

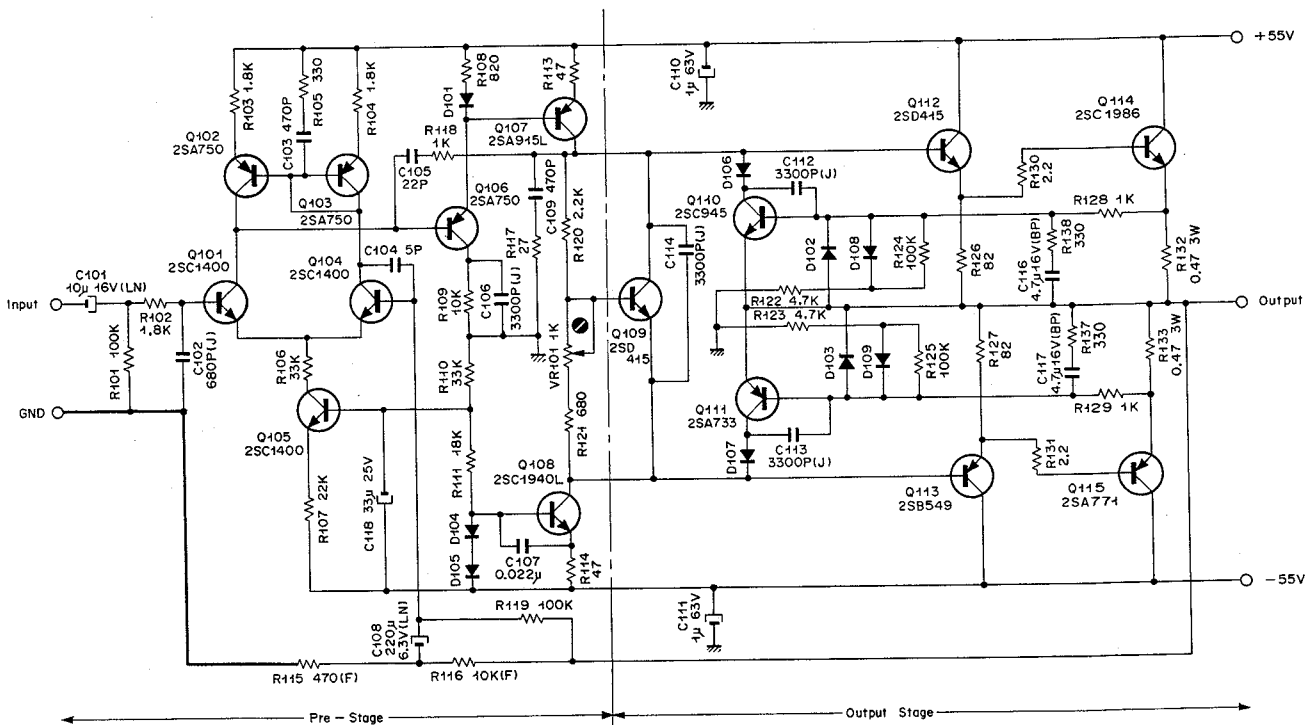

Fig. 2.4.7 Power Amplifier Circuit

Fig. 2.4.8. shows that a change in current flowing across the diode varies the terminal voltage and that  $E_B$  changes with signal current. These changes result in the generation of distortion. It is a matter of course that signal current flowing across the diode will produce distortion. See Fig. 2.4.7. Transistor Q109 that generates bias voltage forms an emitter-follower circuit of class A operation. Thus this circuit does not induce distorted signals.

To utilize the action of each element fully, the N-530 allows the idling current to be varied. Therefore, an appropriate bias voltage can be supplied, and the rise of temperature when no signal is input can be minimized and a low distortion factor can be obtained.

Unless corrected perfectly against temperatures, the bias voltage of power amplifiers in the class B amplifier will increase distortion at low temperature or become unstable at high temperature. It may safely be said that temperature compensation of a transistor can be more properly and effectively carried out by the transistor of the same structure than a diode.

For an ordinary class B amplifier, crossover distortion is reduced by increasing idling current thus overlapping the operating ranges of the positive and negative transistors. The overlap portion acts as a class A amplifier. Generally, the degree of amplification decreases where a change takes place from class A to B and no linear curve is obtained as shown a thick continuous line in Fig. 2.4.9. (A). However, if the circuit shown in Fig. 2.4.7. is current-driven, a linear curve can be obtained at the point of change from class A to B as shown in Fig. 2.4.9. (B).

The  $V_{be}$  voltage of a transistor usually varies depending on its temperature, and decreases as temperature rises. Therefore, if a constant voltage is supplied to  $V$ , as in Fig. 2.4.10., the idling current increases with temperature rise, and the danger of damage to the transistor arises. In order to obtain a certain idling current over a wide range of temperature, this problem can be solved by varying according to the temperature change of  $V_{be}$  of the power transistor, This is accomplished by using the same type of transistor as  $Q_1$  to the bias circuit, and by the thermal connection of this transistor with the output Darlington circuit.

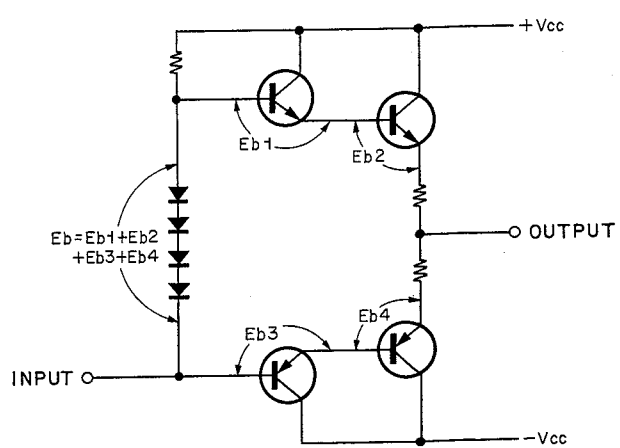

Fig. 2.4.8 Conventional Circuit

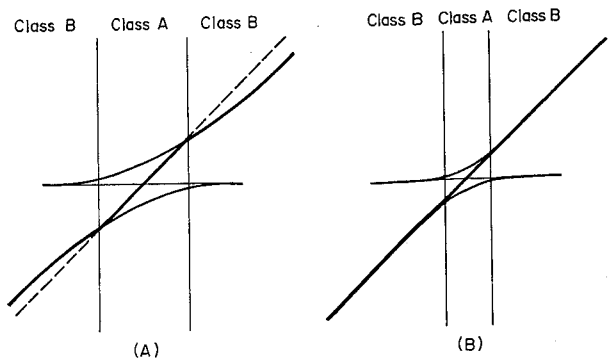
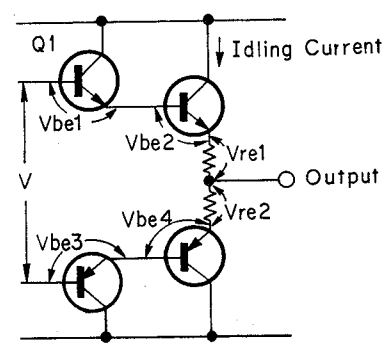

Fig. 2.4.9



$$V_{be} : (\text{Idling Current}) \times R_e$$

$$V = V_{be1} + V_{be2} + V_{be3} + V_{be4} + V_{re1} + V_{re2}$$

Fig. 2.4.10

Fig. 2.4.11 shows the bias circuit of the N-530. The voltage  $V_2$  is given by the following equation:

$$\begin{aligned} V_2 &= V_1 + I_2 R_2 \\ &= I_1 R_1 + I_1 R_2 + I_B R_2 \end{aligned}$$

In this equation,  $I_B$  can be ignored because the  $h_{FE}$  of transistor is high.

Therefore,

$$V_2 \approx I_1 (R_1 + R_2) = V_1 \frac{R_1 + R_2}{R_1}$$

Since  $V_1 (=V_{be})$  varies according to the temperature of the power transistor, the  $V_2$  voltage also varies at the same time, and thus the idling current is stabilized against temperature change.

**(3) Limiter**

The limiter of the N-530 detects the  $V_{ce}$  of the transistor in the last stage of the circuit and controls the  $I_c$  of this transistor in order to protect it. Fig. 2.4.12. shows the limiter of the N-530. Since it is symmetrical, only one side is shown here.

The emitter voltage of the transistor Q1 is  $V_{E1} = V_{E2} - I_c \cdot R_E$ , and the base voltage is;

$$\begin{aligned} V_{B1} &= V_0 + (V_{E2} - V_0) \frac{R_0}{R_B + R_0} \\ &= \frac{R_0}{R_B + R_0} V_{E2} + \frac{R_B}{R_B + R_0} V_0. \end{aligned}$$

The limiter operates when the  $V_{BE}$  of Q1 is above 0.6V. Therefore,

$$\begin{aligned} V_{B1} - V_{E1} &= \frac{R_0}{R_B + R_0} V_{E2} + \frac{R_B}{R_B + R_0} V_0 - V_{E2} \\ &\quad + I_c \cdot R_E \\ &= -\frac{R_B}{R_B + R_0} V_{E2} + \frac{R_B}{R_B + R_0} V_0 + I_c \cdot R_E \\ &= -\frac{R_B}{R_B + R_0} (V_{E2} - V_0) + I_c \cdot R_E \\ &\geq 0.6 \text{ V} \end{aligned}$$

$$\therefore I_c (\text{limit}) = \frac{0.6}{R_E} + \frac{1}{R_E} \cdot \frac{R_B}{R_B + R_0} (V_{CC} - V_{CE} - V_0).$$

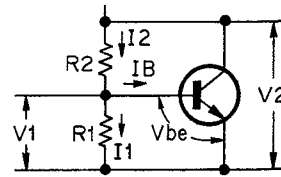

$$\begin{aligned} V_1 &= V_{be} \\ I_2 &= I_1 + I_B \\ I_1 &= \frac{V_1}{R_1} \therefore V_1 = I_1 R_1 \end{aligned}$$

Fig. 2.4.11 Bias Circuit

In these equations, since  $V_0$  is a reference voltage determined by  $R_0/R_1$ , it is constant; and since  $V_{CC}$  is the supply voltage, it is also constant. Therefore,  $I_c$  (limit) is indicated as a parameter determined by the change of  $V_{CE}$ . A diode, D1, is used to protect Q1 when an abnormal reverse voltage is applied.

When  $V_{B1}$  exceeds 0 V (ground level), D2 is turned ON causing  $R_0$  and  $V_0$ , and also the limiter curve, to be changed. When D2 is ON,  $R_0'$  and  $V_0'$  are defined as follows:

$$\begin{aligned} R_0' &: R_0 // R_1 \\ V_0' &: V_0 \text{ divided by } R_0 \text{ and } R_1 \end{aligned}$$

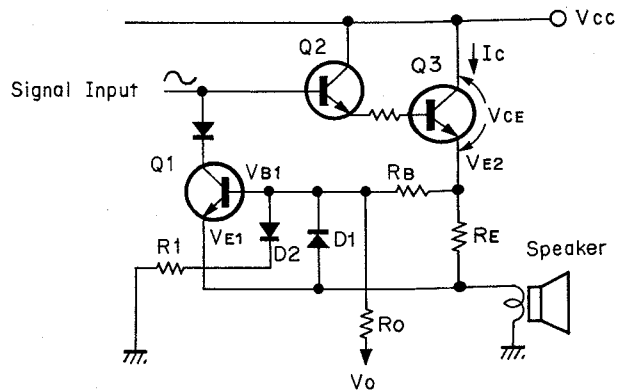

Fig. 2.4.12 Limiter Circuit



### 2.4.5. Protector Circuit

The protector circuit consists of the DC-voltage-detection circuit of the speaker terminals, the temperature-detection circuit of the heat sink, the muting circuit will activate, when the power switch is ON. When a DC voltage above approx. 1.2 V (plus or minus) appears on the speaker terminals, the output of the DC detection circuit is at the ground level, and Q304 is turned ON, Q306 is turned ON, Q307 is turned OFF, and Q308 is also turned OFF. Therefore, the relay RL301 is made to open, protecting the speakers. When the Q308 is turned OFF, power mute signal is generated, this signal resets the auto tuning flip-flops and will mute the outputs of Tone Amp. in the Main P.C.B.

The capacitor C310 between the input of the DC detection circuit and the ground is used to delay the signal. This is to prevent the action of the protector circuit when a momentary signal is supplied to the speaker terminals, so that the protector circuit is allowed to act

only when a prolonged signal is supplied. The time for charging this capacitor differs according to the DC voltage at the speaker terminals: when the DC voltage is high, the circuit acts earlier and when the voltage is low, the circuit acts later. A plus voltage turns ON Q312 and Q311, and turns OFF Q310 and Q309; and a minus voltage turns ON Q310 and Q309, and turns OFF Q312 and Q311.

The transistor Q305 on the heat sink is used for detecting the temperature of the heat sink. It is turned ON when the temperature is above approx. 108°C, so that Q306 is turned ON, Q307 is turned OFF, and Q308 is turned OFF. Therefore the relay RL301 is made to open, protecting the speakers. When the Q308 is turned OFF, power mute signal is generated, this signal resets the auto tuning flip-flops and will mute the outputs of the Tone Amp. in the Main P.C.B.

At the moment the power switch is turned ON, Q307 is turned OFF, and when C309 is charged, it is turned ON.

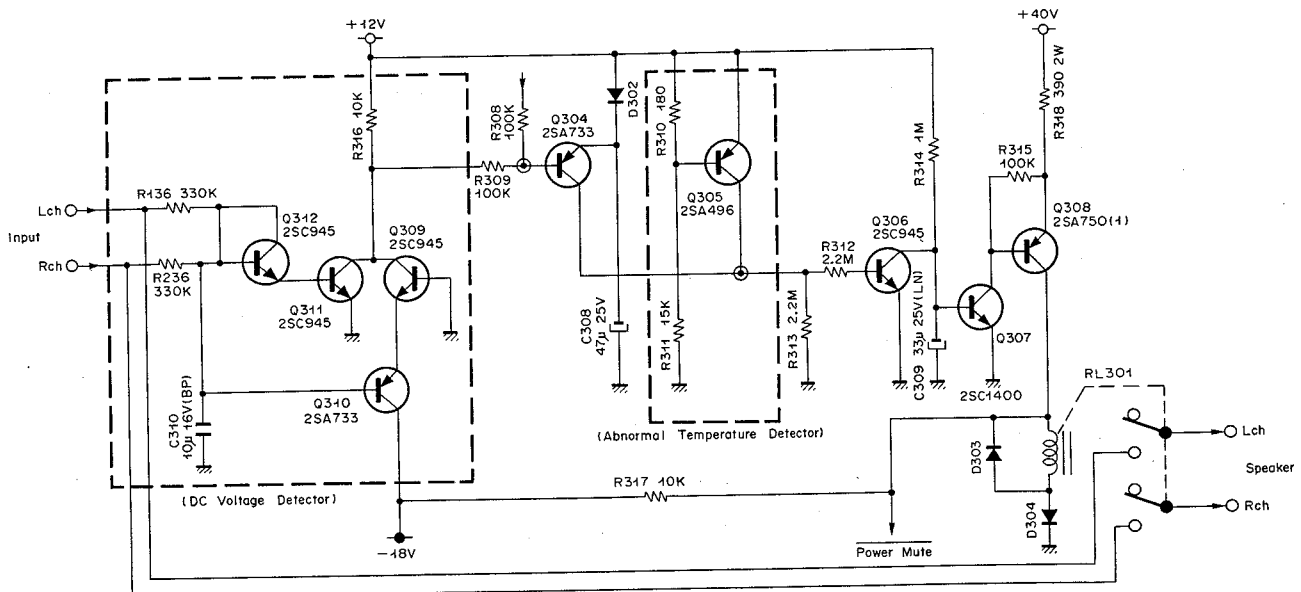

Fig. 2.4.13 Protector Circuit

### 3. REMOVAL PROCEDURES

#### 3.1. Top Cover

Refer to Fig. 3.1. Remove F01 and F02, then F03 (Top Cover).

#### 3.2. Bottom Cover

Refer to Fig. 3.1. Remove F04, then F05 (Bottom Cover).

#### 3.3. Front Panel Ass'y

Refer to Fig. 3.1. Pull out F06 (Volume Knob) and F07 (Preset Volume Knob). Remove F08, then F09 (Front Panel Ass'y).

#### 3.4. Front-end Holder Ass'y

Refer to Fig. 3.2. Remove Top Cover referring to item 3.1. Remove F01, then F02 (Front-end Holder Ass'y). Dial Thread should be removed.

#### 3.5. Power Transformer

Refer to Fig. 3.2. Remove Top Cover referring to item 3.1. Remove F03, F04 and F05, then F06 (Power Transformer).

#### 3.6. Diode Bridge

Refer to Fig. 3.2. Remove Top Cover referring to item 3.1. Remove F07, then F08 (Diode Bridge).

#### 3.7. Power P.C.B. Ass'y and Heat Sink

Refer to Fig. 3.2.

- (1) Remove Top Cover referring to item 3.1. Remove F09, F10, F11, F12, F13 and F14, then F15 (Power P.C.B. Ass'y).
- (2) Preceding above step (1), remove F18, then F19 (Heat Sink).

#### 3.8. Pulley Holder B Ass'y and Pulley Ass'y

Refer to Fig. 3.2. Remove F20, then F21 (Pulley Holder B), and F22 (Pulley Ass'y) by pulling out.

#### 3.9. Front Chassis Ass'y

Refer to Fig. 3.3. Remove Top and Bottom Covers referring to items 3.1 and 3.2.

Remove F01, F02 (Light Intercepting Plate) and F03, then F04 (Front Chassis Ass'y).

Note: Front Chassis Ass'y includes Scale Holder Ass'y.

#### 3.10. Scale Holder Ass'y

Refer to Fig. 3.3. Remove Front Chassis Ass'y referring to item 3.9.

Remove F05, then F06 (Scale Holder Ass'y).

Notes: 1. When removing Scale Holder Ass'y, try not to damage the Dial Thread.

2. Scale Holder Ass'y includes Lamp House Cover Ass'y.

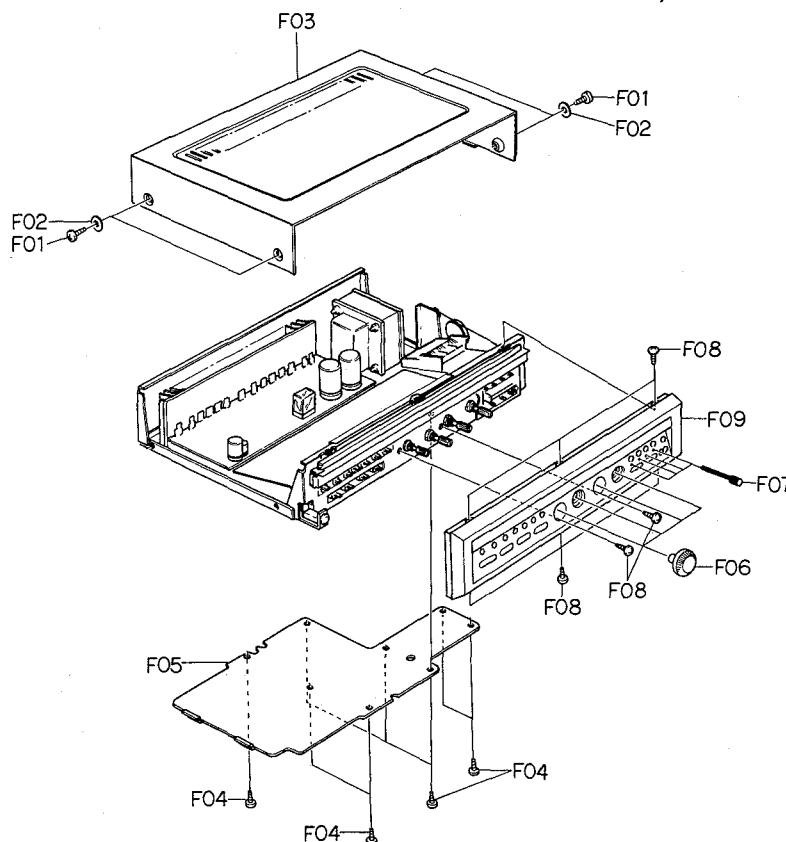

Fig. 3.1

### 3.11. Lamp House Cover Ass'y and Lamp P.C.B. Ass'y

Refer to Fig. 3.3.

- (1) Remove Scale Holder Ass'y referring to item 3.10.  
Remove F07, then F08 (Lamp House Cover Ass'y).
- (2) Remove F09, then F10 (Lamp P.C.B. Ass'y).

### 3.12. Tuning Lamp P.C.B. Ass'y

Refer to Fig. 3.3.

Remove Scale Holder Ass'y referring to item 3.10.

Remove F11 and F12 (Lamp P.C.B. Cover), then F13 (Tuning Lamp P.C.B. Ass'y).

### 3.13. Indicator P.C.B. Ass'y

Refer to Fig. 3.3. Remove Scale Holder Ass'y referring to item 3.10.

Remove F14 (Indicator P.C.B. Ass'y) by releasing the self-interlocking pin.

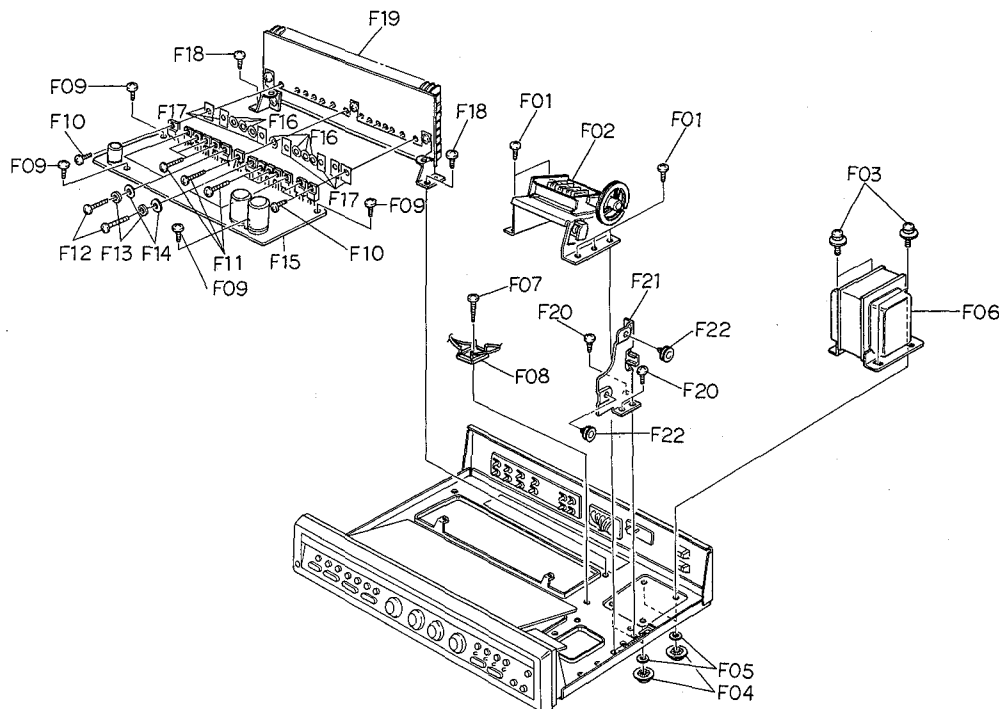

Fig. 3.2

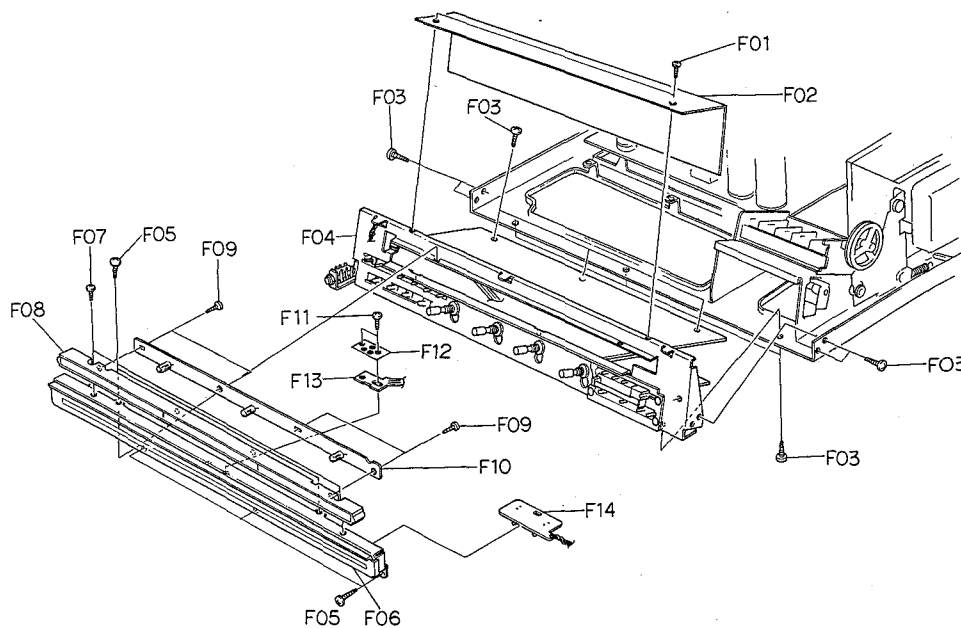

Fig. 3.3

**3.14. Tuning Control Switch Ass'y**

Refer to Fig. 3.4. Remove Front Chassis Ass'y referring to item 3.9.

Remove F01, then F02 (Tuning Control Switch Ass'y).

**3.15. Auto Tuning P.C.B. Ass'y, Preset Volume P.C.B. Ass'y and Preset Switch P.C.B. Ass'y**

Refer to Fig. 3.4.

(1) Remove Tuning Control Switch Ass'y referring to item 3.14.

Remove F03, then F04 (Auto Tuning P.C.B. Ass'y).

(2) Remove F05, then F06 (Preset Volume P.C.B. Ass'y).

(3) Remove F07, then F08 (Preset Switch P.C.B. Ass'y).

(4) Preceding above steps, remove F09 (Control Switch Holder Ass'y).

**3.16. Power Switch**

Refer to Fig. 3.4. Remove Front Chassis Ass'y referring to item 3.9.

Remove F10, then F11 (Power Switch).

**3.17. Main P.C.B. Ass'y and Function P.C.B. Ass'y**

Refer to Fig. 3.4.

(1) Remove Front Chassis Ass'y referring to item 3.9. Remove F12 and F13, then F14 (Main P.C.B. Ass'y).

(2) Remove F15, then F16 (Function P.C.B. Ass'y).

**3.18. Headphone Jack**

Refer to Fig. 3.4. Remove F17 and F18, then F19 (Headphone Jack).

**3.19. Rear Panel Ass'y**

Refer to Fig. 3.5. Remove Top Cover referring to item 3.1. Remove F01 and F02, then Rear Panel Ass'y.

**3.20. 12P Jack, Speaker Terminal and Antenna Terminal**

Refer to Fig. 3.5.

(1) Remove Top Cover referring to item 3.1.

Remove F03, then F04 (12P Jack).

(2) Remove F05, then F06 (Speaker Terminal).

(3) Remove F07 and F08, then F09 (Antenna Terminal).

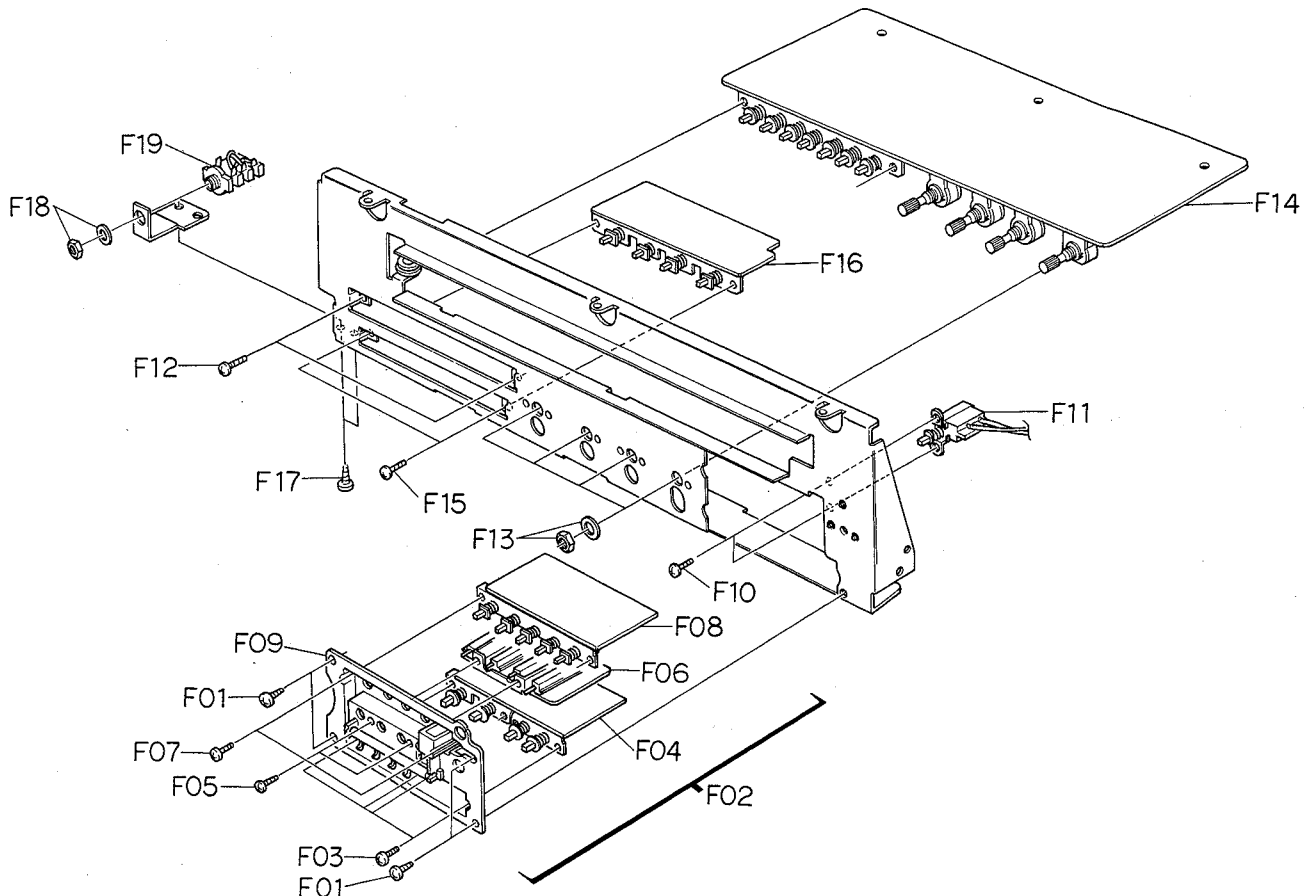

Fig. 3.4

**3.21. AC Outlet**

Refer to Fig. 3.5.

Remove Top Cover referring to item 3.1.  
Remove F10 (AC Outlet) by pushing both projections (plastic material) at sides of Outlet.

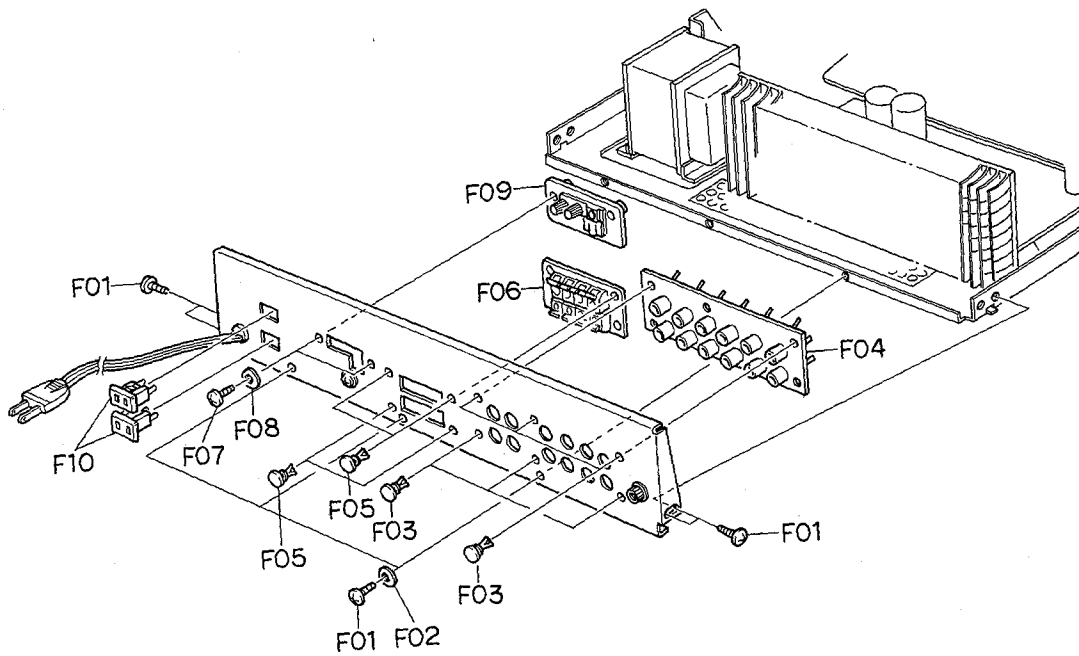

Fig. 3.5

**3.22. Motor Base Ass'y, Front-end Pulley and Front-end**

Refer to Fig. 3.6.

- (1) Remove Top Cover and Front-end Holder Ass'y referring to items 3.1 and 3.4.  
Remove F01, then F02 (Motor Base Ass'y).
- (2) Remove F03 and F04, then F05 (Front-end Pulley).
- (3) Unsolder the soldered part of F06 (Front-end Chassis), then remove F07 (Front-end).

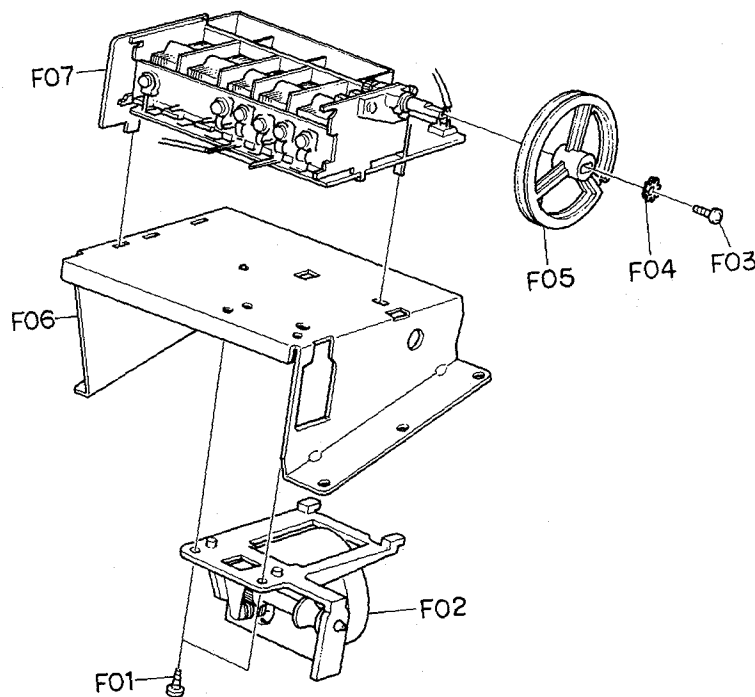

Fig. 3.6

## 4. ADJUSTMENTS AND MEASUREMENTS

### 4.1. FM Tuner Section

#### 4.1.1. Electrical Adjustments and Measurements

Fig. 4.1.1. is a flow chart showing the adjustment procedures and Fig. 4.1.2. is a connection diagram. Fig. 4.1.3. is a diagram for adjustment.

Instruments and devices used for adjustment and measurement are as follows (or equivalent instruments and devices should be used):

- Model 1700B Distortion Measurement System
- Model 1100A Signal Conditioner
- Model 1000A FM Alignment Generator
- Dummy Antenna (an accessory to Model 1000A)
- (The above mentioned are supplied from Sound Technology Inc.)
- Oscilloscope (vertical gain: DC 0.05 V/cm or more)
- Channel Switch Box

As distortion of N-530 is less than 0.15% in Mono, the measuring device must keep its distortion much lower than that of N-530.

However the built-in oscillators of ordinary FM generators

are not recommendable for the adjustment and measurement. The oscillator of M-1700B is preferable for such purposes.

Measurement and adjustment must be performed in a shielded room in principle; otherwise, the frequency should be selected so that no broadcasting frequency will become in a range of the selected frequency  $\pm 400$  kHz. With all the instruments normally connected, make RF level of M-1000A FM Alignment Generator to be minimum and then with Audio Mute of N-530 turned OFF (release), find out a frequency band in which no signal is received by turning Station Preset Control (with Station Memory Switch ON) of N-530, while listening interstation noise. A point of any noise tone variation should be avoided because there will be some weak radio frequency. In this adjustment and measurement, the frequency meeting the above requirements should be set, for example, to 98 MHz on the M-1000 FM Alignment Generator.

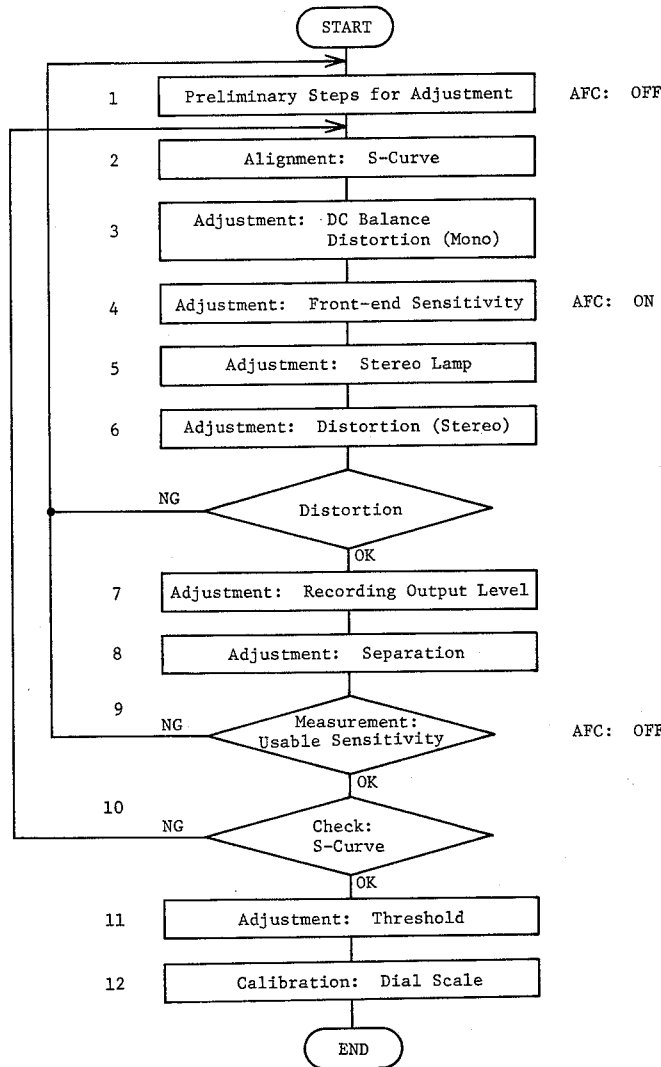

Fig. 4.1.1 Adjustment Flow Chart

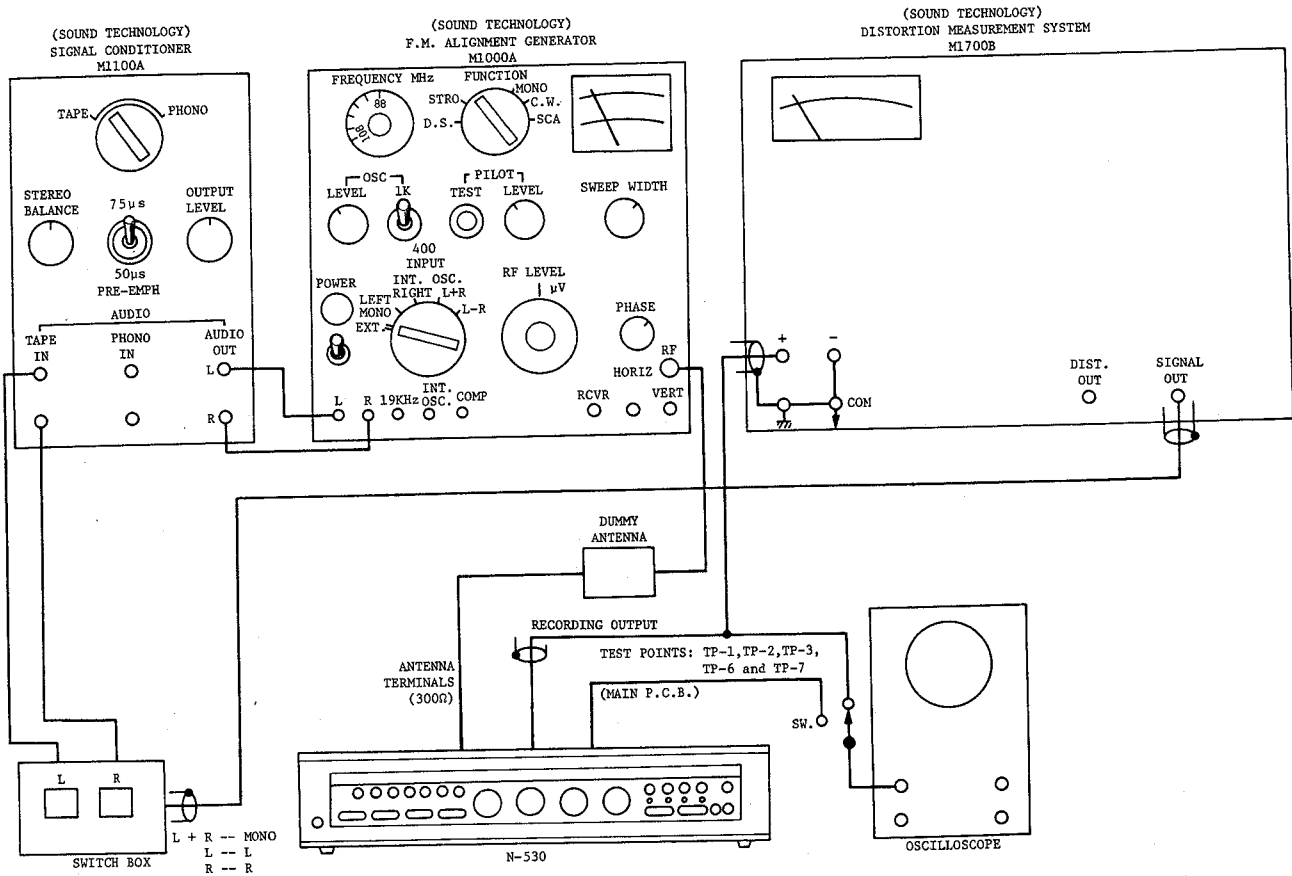

Fig. 4.1.2 Connection Diagram

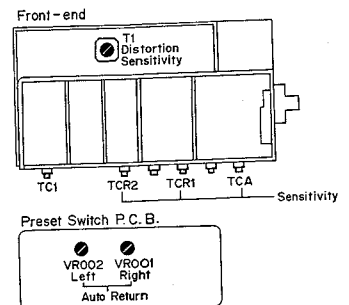
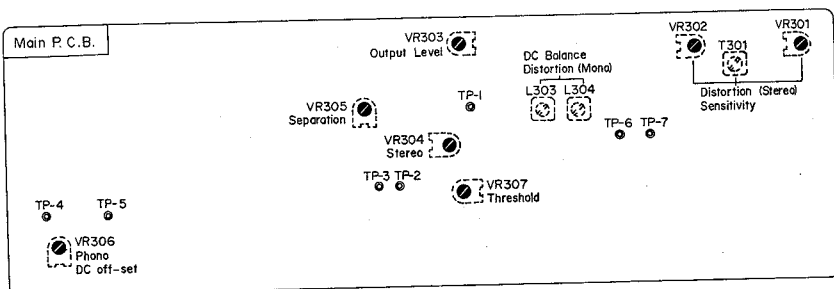
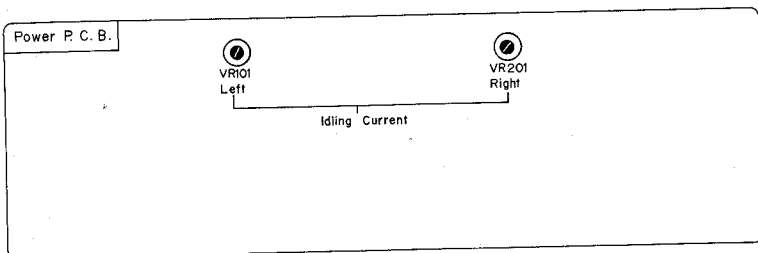

Fig. 4.1.3 Diagram for Adjustment

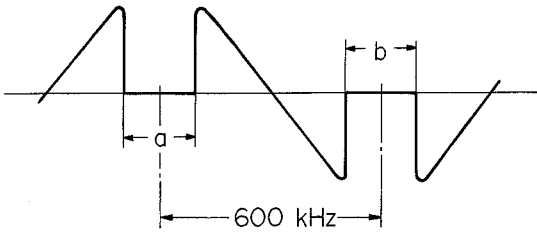

Fig. 4.1.4 S-Curve

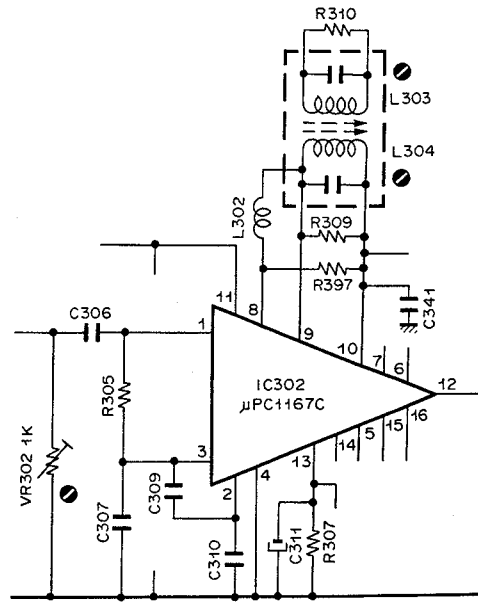

Fig. 4.1.5

- 3. DC Balance and Distortion (Mono)
- 4. Front-end Sensitivity
- 6. Distortion (Stereo)

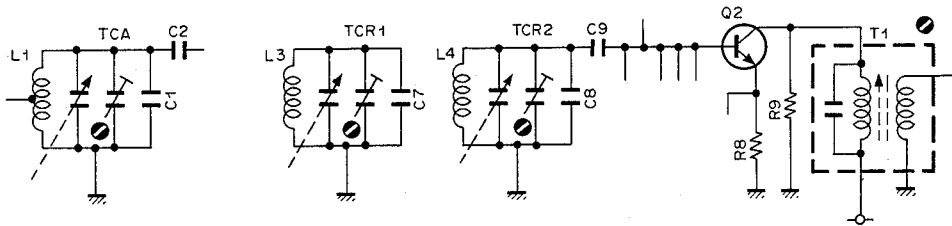

Fig. 4.1.6

- 4. Front-end Sensitivity
- 6. Distortion (Stereo)

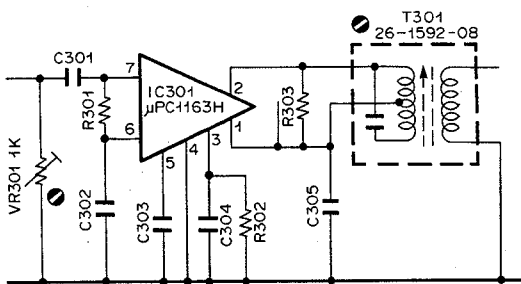

Fig. 4.1.7

- 4. Front-end Sensitivity
- 6. Distortion (Stereo)

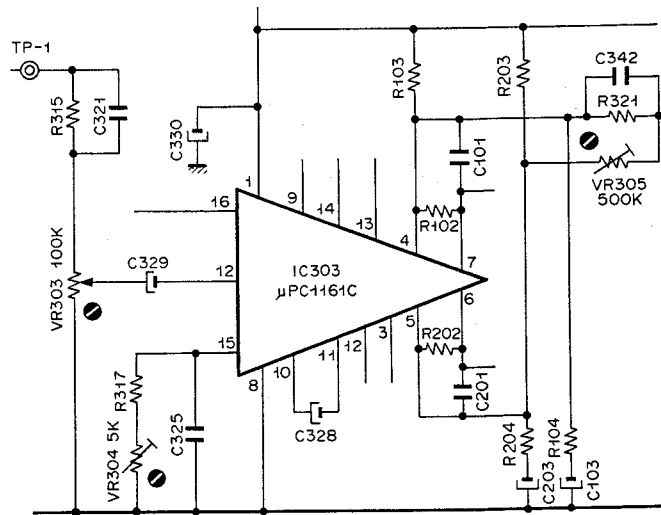

Fig. 4.1.8

- 5. Stereo Lamp
- 7. Recording Output Level



STEP	ITEM	OUTPUT CONNECTION	MODE	ADJUSTMENT	REMARKS
1	Preliminary Steps for Adjustment		N-530 Initial Mode: Function — FM Hi-Blend — OFF Audio Mute — OFF		<ol style="list-style-type: none"> <li>1. Connect the FM Generator to the 300-ohm Balanced Terminals of the N-530.</li> <li>2. Set the frequency of the FM Generator to 98 MHz. (Refer to the preceding explanation for the frequency to be set.)</li> <li>3. Set N-530 to the initial mode (see MODE).</li> <li>4. Signal modulation is performed by adjusting the Signal Output VR of the M1700B Distortion Measurement System. The modulation rate is indicated by the meter on the M1000A FM Generator.</li> <li>5. Test Points: TP-1, TP-2 and TP-3 on the Main P.C.B.</li> <li>6. Inhibit the AFC function by shorting between TP-6 (source) and TP-7 (drain) of FET Q301 on the Main P.C.B. After completion of Tuner Adjustment, remove the short of Q301.</li> </ol>
2	S-Curve Alignment	Oscilloscope to Test Point TP-1	FM Generator: Function — D.S. (Dual Sweep) Frequency — 98 MHz Sweep Width — 600 kHz RF Level — 1 mV (300 Ω) 65 dBf N-530: Mode — Mono		<ol style="list-style-type: none"> <li>1. Select Station A by depressing the Station Memory Switch A.</li> <li>2. Turn the Station Preset Control A to obtain correct S-curve waveform (whose width "a" and "b" are equal) as shown in Fig. 4.1.4.</li> </ol>
3	DC Balance Adjustment Distortion Adjustment (Mono)	Distortion Meter to RECORDING OUTPUT Jacks Oscilloscope between TP-2 and TP-3	FM Generator: Function — CW/Stereo RF Level — 1 mV (300 Ω) 65 dBf N-530: Mode — Mono	Main P.C.B. Quadrature Coils L303, L304	<ol style="list-style-type: none"> <li>1. Do not turn the Frequency Dial on the FM Generator and Station Preset Control A of the N-530.</li> <li>2. With Function Switch of the FM Generator set to CW, adjust L304 to obtain 0 V DC level (within ± 5 mV) on the Oscilloscope.</li> <li>3. With Function Switch set to Stereo, adjust L303 to obtain minimum distortion.</li> </ol>
4	Sensitivity Adjustment of Front-end	Oscilloscope and Distortion Meter to RECORDING OUTPUT Jacks	FM Generator: Function — Stereo Frequency — 98 MHz (See note.) RF Level — 2.2 μV (300 Ω) Input Selector — EXT. M1700B: OSC. — 1 kHz, Level 100% (Signal Modulation rate: 100%) Switch Box: L + R N-530: Mode — Mono	Front-end Coil T1 Trimmer TCA, TCR1, TCR2 Main P.C.B. T301, VR301, VR302	<ol style="list-style-type: none"> <li>1. Adjust coil T1 and Trimmer TCA to obtain 3% or less distortion.</li> <li>2. If a distortion of 3% or less is unable to be achieved, adjustment of coil T301 and semi-fixed volumes VR301 and VR302 will be necessary.</li> <li>3. If a satisfactory result is not obtained in above substep 2, adjustment of Trimmers TCR1 and TCR2 will be necessary.</li> <li>4. After completion of adjustment, remove shorting between TP-6 (source) and TP-7 (drain) of FET Q301 on the Main P.C.B. (AFC: ON).</li> </ol>
5	Stereo Lamp Adjustment		FM Generator: Function — Stereo Frequency — 98 MHz (See note.) RF Level — 1 mV (300 Ω) 65 dBf Pilot Level — 0 Input Selector — EXT. M1700B: OSC. — 1 kHz, Level 100% Switch Box: L + R N-530: Mode — Stereo	Main P.C.B. VR304	<ol style="list-style-type: none"> <li>1. With the Pilot Test Switch on the FM Generator depressed, adjust the pilot level to obtain 80% (pilot signal modulation rate: 7.2%) on the meter of the FM Generator.</li> <li>2. Adjust VR304 so that the Stereo Lamp will light up. As the lamp is illuminated in a certain range of VR, VR304 should be fixed approximately at the center of that range.</li> <li>3. Depress the Mono Switch and set to Mono mode, then make sure that the Stereo Lamp goes out.</li> </ol>
6	Distortion Adjustment (Stereo)	AC Voltmeter and Distortion Meter to RECORDING OUTPUT Jacks	FM Generator: Function — Stereo Frequency — 98 MHz (See note.) RF Level — 1 mV (300 Ω) 65 dBf Pilot Level — 100% (Pilot Signal Modulation rate: 9%) Input Selector — EXT. M1700B: OSC. — 1 kHz, Level 100% Switch Box: L N-530: Mode — Stereo	Main P.C.B. T301, VR301, VR302 Front-end Coil T1	Adjust T301, VR301, VR302 and T1 to obtain 0.2% or less distortion. If the above value does not comply with the specified one, stricter readjustment starting from step 3 "DC Balance Adjustment and Distortion Adjustment (Mono)" is necessary.
7	Adjustment of Recording Output Level	AC Voltmeter to RECORDING OUTPUT Jacks	FM Frequency: Function — Stereo Frequency — 98 MHz RF Level — 1 mV (300 Ω) 65 dBf Pilot Level — 100% Input Selector — EXT. M1700B: OSC. — 400 Hz, Level 50% (Signal Modulation rate: 50%) Switch box: L/R N-530: Mode — Stereo	Main P.C.B. VR303	Adjust VR303 for the left channel with Switch Box "L" and for the right channel with Switch Box "R" to obtain 225 mV on the AC voltmeter.

Note: Do not turn the Frequency Dial on the FM Generator and Station Preset Control A of the N-530.

STEP	ITEM	OUTPUT CONNECTION	MODE	ADJUSTMENT	REMARKS
8	Separation Adjustment	AC Voltmeter and Oscilloscope to RECORDING OUTPUT Jacks	FM Generator: Function – Stereo Frequency – 98 MHz RF Level – 1 mV (300 Ω) 65 dBf Pilot Level – 100% Input Selector – EXT. M1700B: OSC. – 1 kHz, Level 100% Switch Box: L/R N-530: Mode – Stereo	Main P.C.B. VR305	<ol style="list-style-type: none"> <li>1. Set the Switch Box to "L".</li> <li>2. Adjust VR305 to obtain 45 dB or more difference of levels between right and left channels on the AC Voltmeter.</li> <li>3. Set the Switch Box to "R", and make sure that the difference of levels is 45 dB or more.</li> </ol>
9	Usable Sensitivity Measurement	Distortion Meter to RECORDING OUTPUT Jacks	FM Generator: Function – Stereo Frequency – 98 MHz Input Selector – EXT. M1700B: OSC. – 1 kHz, Level 100% Switch Box: L + R N-530: Mode – Mono		<ol style="list-style-type: none"> <li>1. Select Station A by depressing the Station Memory Switch A.</li> <li>2. Turn the Station Preset Control A to obtain minimum distortion.</li> <li>3. Adjust the RF level of the FM Generator to 2.2 μV (300 Ω) and check to insure that the distortion is 3% or less. (At near 3% distortion, make a fine tuning of the N-530 to obtain minimum distortion.) If the above value does not comply with the specified one, stricter readjustment starting from step 2 "S-Curve Alignment" is necessary.</li> <li>4. After completion of measurement, inhibit the AFC function by shorting between TP-6 (source) and TP-7 (drain) of FET Q301 on the Main P.C.B. (AFC: OFF).</li> </ol>
10	S-Curve Check	Oscilloscope to Test Point TP-1	FM Generator: Function – D.S. (Dual Sweep) Frequency – 98 MHz Sweep Width – 600 kHz RF Level – 1 mV (300 Ω) 65 dBf N-530: Mode – Mono		<ol style="list-style-type: none"> <li>1. Select Station A by depressing the Station Memory Switch A.</li> <li>2. Turn the Station Preset Control A to obtain correct S-curve waveform (whose width "a" and "b" are equal) as shown in Fig. 4.1.4. If the waveform is out of range, stricter readjustment starting from step 2 "S-Curve Alignment" will be necessary.</li> </ol>
11	Threshold Level Adjustment		FM Generator: Function – Stereo Frequency – 98 MHz RF Level – 20 dBf, 5.5 μV (300 Ω) 40 dBf, 55 μV (300 Ω) Pilot Level – 100% Input Selector – EXT. M1700B: OSC. – 1 kHz, Level 100% Switch Box: L + R N-530: Mode – Stereo Threshold SW – 20 dBf 40 dBf	Main P.C.B. VR307	<ol style="list-style-type: none"> <li>1. Set the output level of the FM Generator to 20 dBf.</li> <li>2. Select 20 dBf level by depressing the Threshold Selector Switch of the N-530.</li> <li>3. Set the N-530 in Auto Tuning Mode.</li> <li>4. Adjust VR307 on the Main P.C.B. so that the both Tuning Indicators will light up.</li> <li>5. Select 40 dBf level by releasing the Threshold Selector Switch of the N-530, then make sure that the both Tuning Indicators go out.</li> <li>6. Increasing the output level of the FM Generator, check to insure that the both Tuning Indicators will light up in a range of 40 dBf ± 6 dBf. If satisfactory result is not obtained, set the output level of the FM Generator to a range of 20 dBf ± 6 dBf, then repeat readjustment starting from above step 4. It will be satisfactory if the level for illuminating both Tuning Indicators is in a range of 20 dBf ± 6 dBf/40 dBf ± 6 dBf for the position of 20 dBf/40 dBf of the Threshold Selector Switch.</li> </ol>
12	Dial Calibration			Front-end TC1	<ol style="list-style-type: none"> <li>1. Receiving the station with its frequency already known or setting the FM Generator, turn the Station Preset Control A to that frequency after selecting the Station A by depressing the Station Memory Switch A. Adjust TC1 so that the both Tuning Indicators (green) will light up.</li> <li>2. After completion of measurement, remove shorting between TP-6 (source) and TP-7 (drain) of FET Q301 on the Main P.C.B. (AFC: ON).</li> </ol>

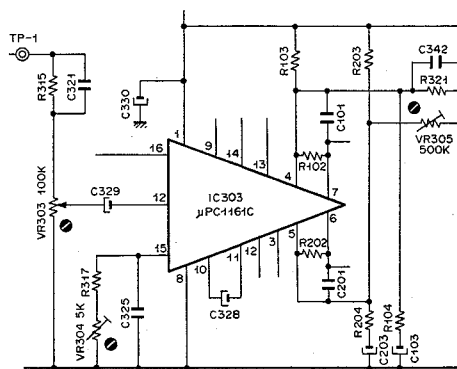

Fig. 4.1.9  
8. Separation

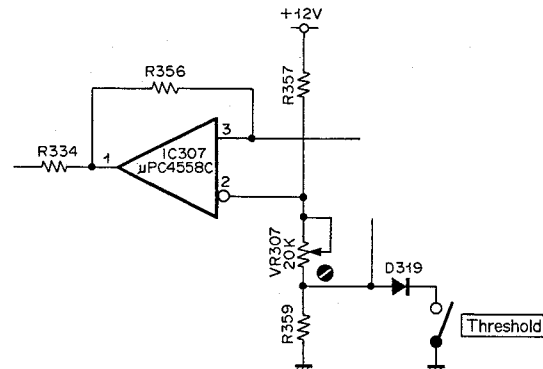

Fig. 4.1.10  
11. Threshold Level

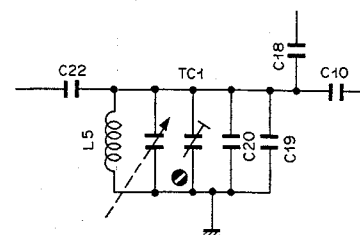

Fig. 4.1.11  
12. Dial Calibration

#### 4.1.2. Auto-Return Scale Calibration

The following calibration limits the upper end and lower end of the scale:

- (1) Remove FM Generator from the FM Antenna Terminals of the N-530.
- (2) Depress the Station Memory Switch A at any mode of the N-530.
- (3) Turn counterclockwise the knob of the Station Preset Control A until it stops (click sound can be heard).
- (4) Refer to Fig. 4.1.12. Adjust VR002 on the Preset Switch P.C.B. Ass'y till the Tuning Pointer indicates 87.5 MHz (75.5 MHz in Japan) at the condition of above step (3).
- (5) Depress the Station Memory Switch D.
- (6) Turn clockwise the knob of the Station Preset Control D until it stops.
- (7) Adjust VR001 on the Preset Switch P.C.B. Ass'y till the Tuning Pointer indicates 108.5 MHz (90.5 MHz in Japan).
- (8) Repeat steps from (2) three times (or more) as the limitation of one end will be slightly changed when other end is calibrated.

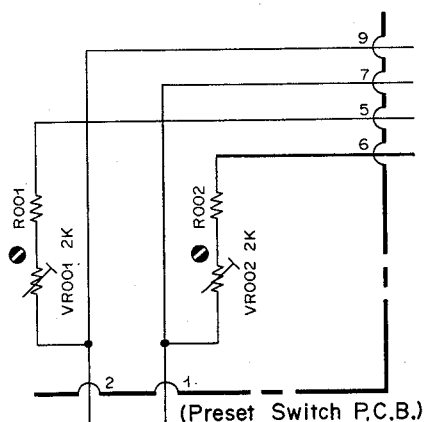

Fig. 4.1.12 Auto-Return Scale Calibration

#### 4.2. Preamplifier Section

##### 4.2.1. Signal-to-Noise Ratio Measurement

###### (1) Phono Input/Recording Output

Mode:

Function — Phono  
Tape Monitor — OFF (Source)

Measurement:

Short Phono Input Jacks with shorting plugs (whose positive and negative sides are shorted). Connect an AC Voltmeter to Tape Recording Output Jacks and measure the level through IHF A Network.

Reference Tape Recording Output Level: 150 mV (0 dB)

###### (2) Aux. Input/Preamp. Output

Mode:

Function — Aux.  
Tape Monitor — OFF (Source)  
Tone Controls (Bass, Treble) — Center Position  
Balance Control — Center Position  
Loudness Switch — OFF  
Volume Control — Max. Position

Measurement:

Short Aux. Input Jacks with shorting plugs. Connect an AC Voltmeter to Preamp Output Jacks and measure the level through IHF A Network.

Reference Preamp Output Level: 1 V (0 dB)

##### 4.2.2. Distortion Measurement

###### (1) Phono Input/Recording Output

Mode:

Function — Phono  
Tape Monitor — OFF (Source)

Measurement:

Connect an AC Voltmeter and a distortion meter to the Tape Recording Output Jacks.

Feed in 1 kHz to Phono Input Jacks and adjust the input level (oscillator output level) to obtain 2 V on the AC Voltmeter, then measure the distortion.

###### (2) Aux. Input/Preamp. Output

Mode:

Function — Aux.  
Tape Monitor — OFF (Source)  
Tone Controls (Bass, Treble) — Center Position  
Balance Control — Center Position  
Loudness Switch — OFF  
Volume Control — Max. Position

Measurement:

Connect an AC Voltmeter and a distortion meter to the Preamp Output Jacks.

Feed in 1 kHz to Aux. Input Jacks and adjust the input level to obtain 1 V on the AC Voltmeter, then measure the distortion.

#### 4.2.3. Phono Eq. Amp. DC Offset Adjustment

- (1) Short Phono Input Jacks with shorting plugs (of which positive and negative sides are shorted).
- (2) Refer to Fig. 4.2.1. Connect a DC Voltmeter to Test Point TP-4, and adjust VR306 to obtain  $-0.5\text{ V}$  (to  $-1\text{ V}$ ) on the DC Voltmeter.
- (3) Connect a DC Voltmeter to Test Point TP-5, and check to insure that the level is within  $-0.5\text{ V}$  to  $-1\text{ V}$  on the DC Voltmeter.

If the above value cannot be obtained, adjust VR306 to obtain  $-0.5\text{ V}$  (to  $-1\text{ V}$ ) on the DC Voltmeter at TP-5. Then check to insure whether the level at TP-4 is within a range of  $-0.5\text{ V}$  to  $-1\text{ V}$  on the DC Voltmeter.

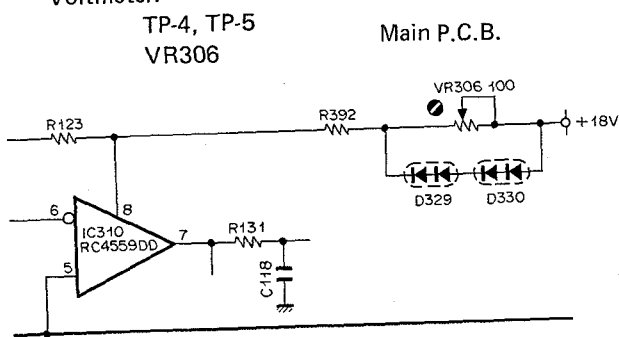

Fig. 4.2.1 Phono Eq. Amp. DC Offset Adjustment

#### 4.3. Power Amplifier Section

##### 4.3.1. Idling Current Adjustment

- (1) Connect a DC Mili-voltmeter across R132, 133 (R232, 233) on the Power P.C.B. as shown in Fig. 4.3.1.
- (2) Connect an 8-ohm 60 watts or more wattage load resistor and Distortion Meter to the Speaker Terminal.
- (3) Refer to Fig. 4.3.2. Adjust VR101 (VR201) on the Power P.C.B. to obtain approx. 10 mV on the DC Mili-voltmeter.
- (4) Connect an Oscillator to the Main Amplifier Input Jacks.
- (5) Check to insure whether the distortions at 1 kHz and 10 kHz satisfy the following specifications (output wattage should be 55 watts in each frequency):
  - 1 kHz: 0.003% or less
  - 10 kHz: 0.006% or less

#### Note:

As long as all parts meet the specifications, the published characteristics can be obtained without readjustment. Generally, no adjustment is required if only defective parts are replaced at repair. Observe the following precautions when repairing defective parts:

- (1) Relocation a wiring can cause larger distortion. Do not relocate the wiring.
- (2) Fully tighten or retighten the wrapping wires to decrease the resistance between wires and terminals.

- (3) If a new semiconductor is installed in the Power Block Ass'y, a perfect balance should be held between it and the existing semiconductors in the block.

An imperfect balance can cause larger distortion or unwanted oscillation. To maintain a good balance, connect an 8-ohm 60 watts load resistor to the speaker terminal, then measure the distortion and check that it meets the above "Idling Current Adjustment" (in this case, the residual distortion factor of the instrument should be lower than the specified value).

- (4) Incorrect idling current will increase the distortion. Usually, the idling current of power transistors Q114 and Q115 (Q214 and Q215) on the Power Block Ass'y is approx. 10 mA.
- (5) Improper locations of power supply wiring will increase the distortion at 55 watts output.

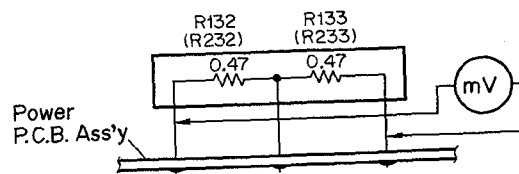

Fig. 4.3.1

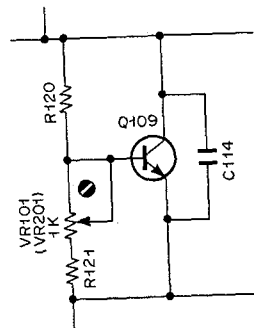

Fig. 4.3.2 Idling Current Adjustment

## 5. DIAL THREADING AND SCALE CALIBRATION

### 5.1. Dial Threading

#### 5.1.1. How to prepare dial thread

Refer to Fig. 5.1.1. Prepare a 2,000 mm long thread and a thread guide. At an end of the thread, make a ring of approx. 3.4 mm ID and fix the thread guide in the ring.

The length of the thread between the thread guide at one end and the other should be approx. 1,900 mm. After rounding off the thread guide with pliers, adhere the guide and ring with AVDEL BOND #C-2.

Thread: Hamilton Super 505 (Wadding: Aramid (Kevlar); Braid: Nylon Rope) with a length of 2,000 mm.

#### 5.1.2. How to set dial threading

(1) Referring to Fig. 5.1.2., set a dial thread to a protrusion "A" of F01 (Front-end Pulley) by way of protrusion "B".

(2) Referring to Fig. 5.1.3., set the dial thread by way of F02 through F09 in that order, and wind the thread approx. 2 turns on F01.

Turn the thread around F05 (Front-end Gear) for 3 times and pass it between pulley and Pulley Holder C Ass'y of F07. (F07 should move freely.) Make certain to place the thread on F08 (a protrusion of Pulley Holder A). (F08 is temporarily used to limit the total length of the thread).

(3) Referring to Fig. 5.1.4., at an end (free end) of the thread, make a ring and fix a thread guide in the ring, then hook the ring to protrusion "D" by way of protrusion "C".

(4) Refer to Fig. 5.1.5. After fully tighten the end of the thread in the illustrated direction to remove the looseness of the thread, bring the thread guide close to "D" and round it off.

Make a knot as shown in the figure, then adhere it with AVDEL BOND #C-2.

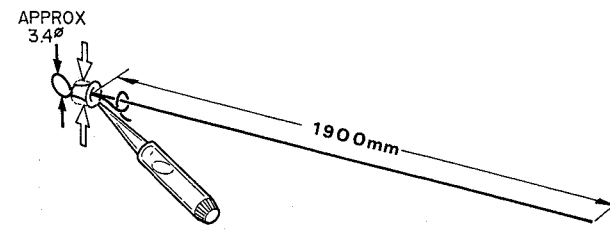

Fig. 5.1.1

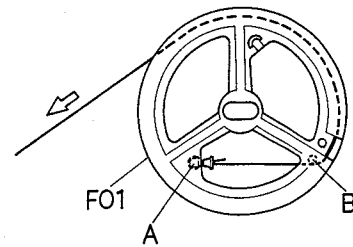

Fig. 5.1.2

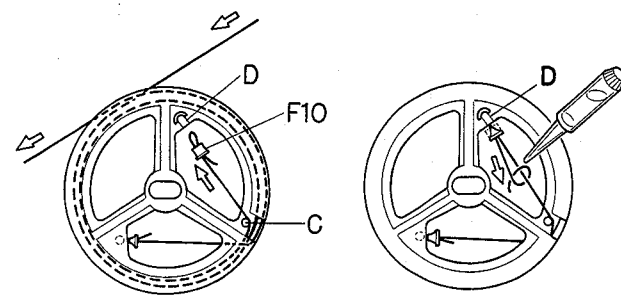

Fig. 5.1.4

Fig. 5.1.5

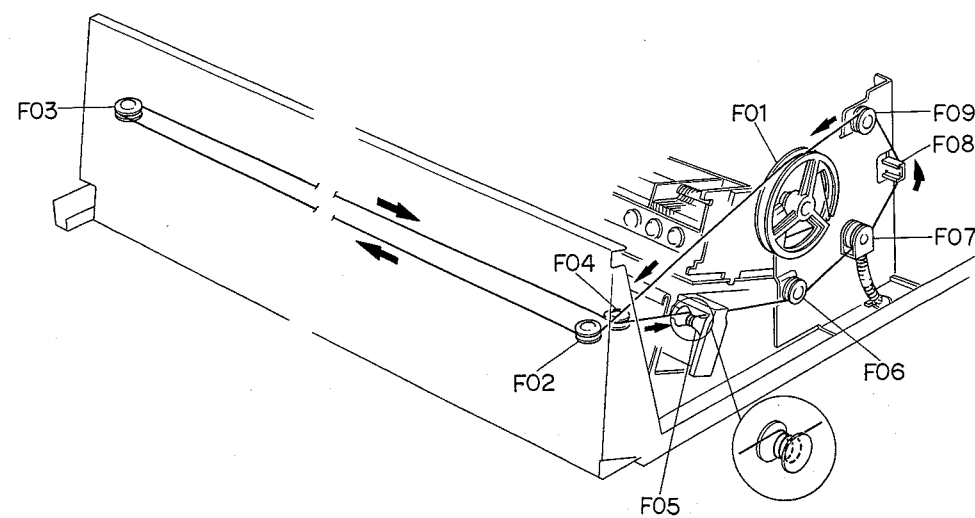

Fig. 5.1.3

(5) Refer to Fig. 5.1.6. After removing the thread from F08 to place the thread in "E" position, loosen a screw and move the base plate of F07 fully toward the front panel side, and then tighten the screw temporarily. Turn ON the Power Switch, then depress the Automatic Scanning Switch. Motor starts to rotate, but the pointer does not move as the thread tension is weak.

Loosen the screw and move F07 slowly backward to the rear panel to tighten the threading, and then tighten the screw at the position over 2 mm backward from the position where the tuning pointer starts to move.

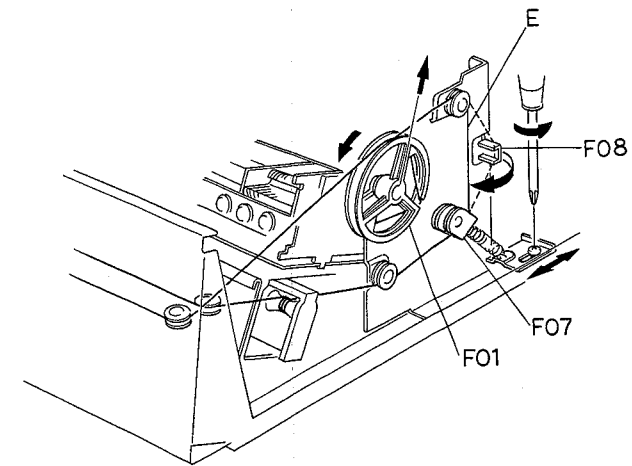

Fig. 5.1.6

### 5.2. Scale Calibration

(1) Before calibration, fully turn F01 in Fig. 5.1.3. counterclockwise.

(2) Referring to Fig. 5.2.1., bring F11 (Lamp Base Ass'y) to the left end and move F12 (Wire Stopper) backward with pliers.

(3) Referring to Fig. 5.2.2., set a dial thread into the groove on the protrusion "B" and "B'" of F11 (Lamp Base Ass'y).

(4) Perform the scale calibration as follows:

(a) Overseas Band

1) With mounting a Dial Scale Plate Position F11 (Lamp Base Ass'y) in Fig. 5.2.1. so that the center of the pointer corresponds to the illustrated position on the scale as shown in Fig. 5.2.3.

2) Without mounting a Dial Scale Plate Referring to Fig. 5.2.1., position F11 so that the center of the pointer corresponds to the mark on F13 (Scale Holder).

(b) Japan Band

1) With mounting a Dial Scale Plate Position F11 in Fig. 5.2.1. so that the center of the pointer corresponds to the illustrated position on the scale as shown in Fig. 5.2.4.

2) Without mounting a Dial Scale Plate Referring to Fig. 5.2.1., position F11 so that the center of the pointer corresponds to 2.5 mm away in the left from the mark on F13.

(5) Return F12 (Wire Stopper) in Fig. 5.2.1. to the original position by pushing it forward with pliers to fix the thread.

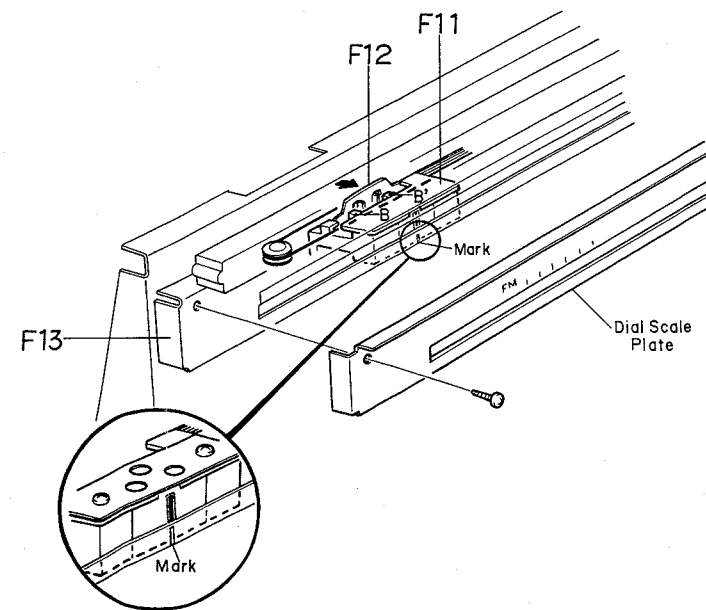

Fig. 5.2.1

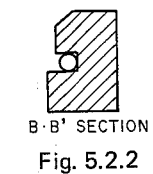

Fig. 5.2.2

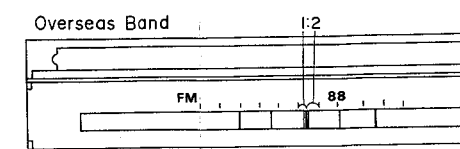

Fig. 5.2.3

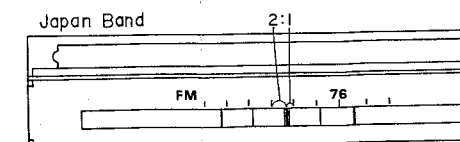

Fig. 5.2.4

6. MOUNTING DIAGRAMS AND PARTS LIST

Note: Mounting diagram shows a dip side view of the printed circuit board.

6.1. Main P.C.B. Ass'y

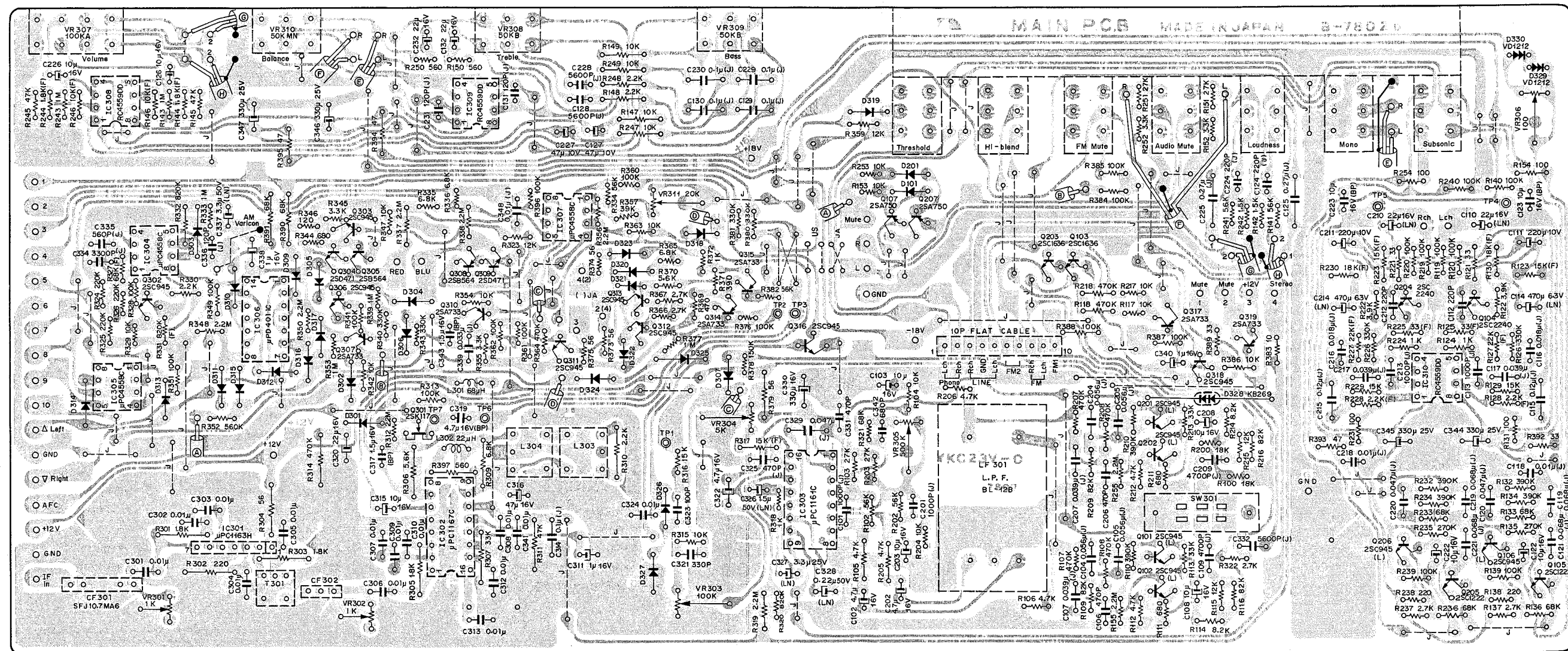

Fig. 6.1

Note: Diode is 1S1555 unless otherwise specified.

Schematic Ref. No.	Part No.	Description	Schematic Ref. No.	Part No.	Description
	BA03981A	Main P.C.B. Ass'y (50μs)	CF301	0B08565A	Ceramic Filter SFJ10.7MA6-7
	BA04056A	Main P.C.B. Ass'y (75μs)	CF302	0B08556A	Ceramic Filter SEF10.7MM-A
	BA04057A	Main P.C.B. Ass'y (75μs/50μs)	VR301,302	0B07178A	Semi-fixed Volume 1K
	- FM IF -		R301, 303	0B05614A	Carbon Resistor 1.8K ERD-25T J
IC301	0B06117A	IC μPC1163H	305		
IC302	0B06184A	IC μPC1167C	R302	0B01933A	Carbon Resistor 220 ERD-25T J
Q301	0B06129A	FET 2SK117	R304	0B05947A	Fail Safe Type Resistor 56 ERD-14F J
D301	0B01909A	Silicon Diode 1S1555	R306	0B01887A	Carbon Resistor 5.6K ERD-25T J
T301	0B08464A	IF Coil	R307	0B05509A	Carbon Resistor 33K ERD-25T J
L301	0B06561A	Inductor 68μH	R309	0B01682A	Carbon Resistor 6.8K ERD-25T J
L302	0B06598A	Inductor 22μH	R310	0B05622A	Carbon Resistor 2.2K ERD-25T J
L303	0B06596A	Quadrature Coil A-1	R311	0B05641A	Carbon Resistor 47K ERD-25T J
L304	0B06597A	Quadrature Coil A-2	R312	0B05672A	Carbon Resistor 2.2M ERD-25V J
			R313	0B01920A	Carbon Resistor 100K ERD-25V J

Schematic Ref. No.	Part No.	Description	Schematic Ref. No.	Part No.	Description	Schematic Ref. No.	Part No.	Description	Schematic Ref. No.	Part No.	Description	
R314	OB01684A	Carbon Resistor 470K ERD-25V J	C332	OB05659A	Mylar Capacitor 5600P 50V J	R390,391	OB01902A	Carbon Resistor 68K ERD-25V J	R128,228	OB09201A	Metal Film Resistor 2.2K SN15K2E F	
R397	OB05678A	Carbon Resistor 560 ERD-25V J	C342	0T04027A	Ceramic Capacitor 680P 50V	C323	OB01288A	Ceramic Capacitor 100P 50V	R129,229	OB05591A	Carbon Resistor 15K ERD-25V J	
C301-310 312, 313 341	OB01290A	Ceramic Capacitor 0.01μ 50V (13 pcs.)			-- FM Tuning Logic --	C324	OB01290A	Ceramic Capacitor 0.01μ 50V	R130,230	OB09205A	Metal Film Resistor 18K SN15K2E F	
C311	OB01405A	Electrolytic Capacitor 1μ 16V	IC304,305	OB06124B	IC μPC4558C	C334	OB01804A	Mylar Capacitor 3900P 50V J	R131,154	OB05558A	Carbon Resistor 100 ERD-25V J	
C314	OB01780A	Mylar Capacitor 0.1μ 50V J	307			C335	OB05788A	SP Capacitor 560P 50V J	231,254			
C315	OB01412A	Electrolytic Capacitor 10μ 16V	IC306	OB06178A	IC μPD4011C	C336	OB05787A	SP Capacitor 120P 50V J	R132,134	OB05595A	Carbon Resistor 390K ERD-25V J	
C316	OB01403A	Electrolytic Capacitor 47μ 16V	Q302,303	OB06100A	Transistor 2SC945	C337	OB09185A	Electrolytic Capacitor 3.3μ 50V (LN)	232,234			
C317	OB09164A	Electrolytic Capacitor 1.5μ 16V (BP)	306,311			C338,340	OB01405A	Electrolytic Capacitor 1μ 16V	R133,136	OB01902A	Carbon Resistor 68K ERD-25V J	
C319	OB09181A	Electrolytic Capacitor 4.7μ 16V (BP)	312,313			C339	OB05583A	Mylar Capacitor 0.033μ 50V J	233,236			
C320	OB01862A	Electrolytic Capacitor 22μ 16V	316,318			C343	OB09164A	Electrolytic Capacitor 1.5μ 16V (BP)	R135,235	OB05600A	Carbon Resistor 270K ERD-25V J	
			Q304,309	OB06066A	Transistor 2SD471	C348	OB05681A	Mylar Capacitor 0.01μ 50V J	R137,237	OB01782A	Carbon Resistor 2.7K ERD-25V J	
			Q305,308	OB06069A	Transistor 2SB564				R138,238	OB05608A	Carbon Resistor 220 ERD-25V J	
			Q307,310	OB06013A	Transistor 2SA733				R392	OB09210A	Fail Safe Type Resistor 33 RDF25S J	
			314,315						R393	OB09177A	Fail Safe Type Resistor 47 RDF25S J	
			317,319						C110,210	OB09137A	Electrolytic Capacitor 22μ 16V (LN)	
			D302-307	OB01909A	Silicon Diode 1S1555 (25 pcs.)				C111,211	OB05899A	Electrolytic Capacitor 220μ 10V	
			309-327						C112,212	OB01289A	Ceramic Capacitor 220P 50V	
IC303	OB06153A	IC μPC1161C	D328	OB01702A	Silicon Varistor KB-269	VR307	OB07247B	Volume 100K(A)x2	C113,213	OB05550A	Mylar Capacitor 1000P 50V J	
Q101,102 201,202	OB01872A	Transistor 2SC945 (L)	VR311	OB07261A	Semi-fixed Volume 20K	VR308,309	OB07249B	Volume 50K(B)x2	C114,214	OB09152A	Electrolytic Capacitor 470μ 6.3V (LN)	
Q103,203	OB06070A	Transistor 2SC1636	R316	OB05591A	Carbon Resistor 15K ERD-25V J	VR310	OB07248B	Volume 50K(MN)x2	C115,215	OB05909A	Mylar Capacitor 0.12μ 50V J	
LF301	OB08557A	LPF BL-12B	R319,337	OB05672A	Carbon Resistor 2.2M ERD-25V J	R141,241	OB05563A	Carbon Resistor 56K ERD-25V J	C116,216	OB05832A	Mylar Capacitor 0.018μ 50V J	
VR303	OB03832A	Semi-fixed Volume 100K	338,348			R142,242	OB05505A	Carbon Resistor 1.5K ERD-25V J	C117,217	OB05660A	Mylar Capacitor 0.039μ 50V J	
VR304	OB03831A	Semi-fixed Volume 5K	350,356			R143,243	OB05564A	Carbon Resistor 1M ERD-25V J	C118,218	OB05681A	Mylar Capacitor 0.01μ 50V J	
VR305	OB09107A	Semi-fixed Volume 500K	R320,332	OB05674A	Carbon Resistor 820K ERD-25V J	R144,244	OB09199A	Metal Film Resistor 1.8K SN15K2E F	C119,121	OB05682A	Mylar Capacitor 0.068μ 50V J	
R100,200	OB05561A	Carbon Resistor 18K ERD-25V J	R323,359	OB05650A	Carbon Resistor 12K ERD-25V J	R145,245	OB05562A	Carbon Resistor 47K ERD-25V J	219,221			
R102,202	OB05563A	Carbon Resistor 56K ERD-25V J	R324,325	OB05596A	Carbon Resistor 220K ERD-25V J	R146,246	OB09198A	Metal Film Resistor 10K SN15K2E F	C120,220	OB05796A	Mylar Capacitor 0.047μ 50V J	
R103,203	OB05538A	Carbon Resistor 27K ERD-25V J	326			R147,149	OB01833A	Carbon Resistor 10K ERD-25V J	C122,222	OB01412A	Electrolytic Capacitor 10μ 16V	
R104,117 204,217 315	OB01833A	Carbon Resistor 10K ERD-25V J	R327	OB09196A	Metal Film Resistor 68K SN15K2E F	249,253			C123,223	OB09163A	Electrolytic Capacitor 10μ 16V (BP)	
R105,106	OB01795A	Carbon Resistor 4.7K ERD-25V J	R328,341	OB01920A	Carbon Resistor 100K ERD-25V J	R148,248	OB05566A	Carbon Resistor 2.2K ERD-25V J	C344,345	OB05793A	Electrolytic Capacitor 330μ 25V	
112,205			349,351			R150,250	OB05678A	Carbon Resistor 560 ERD-25V J				
206,212			360,361			R151,251	OB05538A	Carbon Resistor 27K ERD-25V J				
R107,108	OB05700A	Carbon Resistor 470K ERD-25V J	362,376			R152,252	OB01793A	Carbon Resistor 3.3K ERD-25V J				
118,207			384,385			R394,395	OB09177A	Fail Safe Type Resistor 47 RDF25S J				
208,218			387,388			C124,224	OB09155A	PP Capacitor 220P 35V J	TP1-7	OB07802D	Main P.C.B.	
R109,209	OB01564A	Carbon Resistor 82K ERD-25V J	396			C125,225	OB09154A	Mylar Capacitor 0.27μ 50V J		OB03924A	FET Gate Pin	
R110,210	OB05595A	Carbon Resistor 390K ERD-25V J	R329,342	OB01833A	Carbon Resistor 10K ERD-25V J	C126,226	OB09148A	Electrolytic Capacitor 10μ 16V (LN)		OB07242A	Push Switch (1 pce.)	
R111,211	OB05559A	Carbon Resistor 680 ERD-25V J	347,354			C127,227	OB01836A	Electrolytic Capacitor 47μ 10V		OJ03956A	Shield Plate A D102 (1 pce.)	
R113,213	OB01879A	Carbon Resistor 33K ERD-25V J	363,386			C128,228	OB05659A	Mylar Capacitor 5600P 50V J		OJ03957C	Shield Plate B D102 (1 pce.)	
R114,214	OB01878A	Carbon Resistor 8.2K ERD-25V J	R330	OB05566A	Carbon Resistor 2.2K ERD-25V J	C129,130	OB01780A	Mylar Capacitor 0.1μ 50V J		OB05231A	Flat Cable (1 pce.)	
R155,255	OB05672A	Carbon Resistor 2.2M ERD-25V J	R331	OB09097A	Metal Film Resistor 820K SN15K2E F	229,230				OB08542A	Wrapping Pin 1P L Type (5 pcs.)	
R317	OB09195A	Metal Film Resistor 15K SN15K2E F	R333,339	OB05564A	Carbon Resistor 1M ERD-25V J	C131,231	OB05787A	SP Capacitor 120P 50V J		OB08543A	Wrapping Pin 2P L Type (2 pcs.)	
R318	OB01781A	Carbon Resistor 1K ERD-25V J	353,377			C132,232	OB01862A	Electrolytic Capacitor 22μ 16V		OB08545A	Wrapping Pin 4P L Type (2 pcs.)	
R321	OB01902A	Carbon Resistor 68K ERD-25V J	R334,382	OB05563A	Carbon Resistor 56K ERD-25V J	C346,347	OB05793A	Electrolytic Capacitor 330μ 25V		OB08566A	Wrapping Pin 7P U Type (1 pce.)	
R322	OB01782A	Carbon Resistor 2.7K ERD-25V J	R335,336	OB01877A	Carbon Resistor 6.8K ERD-25V J					OB08581A	Wrapping Pin 5P U Type (2 pcs.)	
R379	OB05947A	Fail Safe Type Resistor 56 ERD-14F J	365						R115,215	OB05650A	Carbon Resistor 12K ERD-25V J (75 μs, 75 μs/50 μs)	
R383	OB05938A	Fail Safe Type Resistor 10 ERD-14F J	R340,343	OB01921A	Carbon Resistor 330K ERD-25V J	IC310	OB06205A	IC RC4559DD		R116,216	OB01564A	Carbon Resistor 82K ERD-25V J (75 μs, 75 μs/50 μs)
C101,201	OB05550A	Mylar Capacitor 1000P 50V J	380,381			Q104,204	OB06142A	Transistor 2SC2240		R109,209	OB05652A	Mylar Capacitor 4700P 50V J (75 μs, 75 μs/50 μs)
C102,202	OB01389A	Electrolytic Capacitor 4.7μ 16V	R344	OB05559A	Carbon Resistor 680 ERD-25V J	Q105,205	OB06062A	Transistor 2SC1222		SW301	OB07029A	Slide Switch (75 μs/50 μs)
322			R345,355	OB01793A	Carbon Resistor 3.3K ERD-25V J	Q106,206	OB01872A	Transistor 2SC945L				
C103,108 203,208	OB01412A	Electrolytic Capacitor 10μ 16V	R346	OB05570A	Carbon Resistor 120 ERD-25V J	D329,330	OB06107A	Diode VD1212				
C104,105 204,205	OB05813A	Mylar Capacitor 0.056μ 50V J	R352	OB05665A	Carbon Resistor 560K ERD-25V J	VR306	OB09153A	Semi-fixed Volume 100				
C106,206 331	OB01716A	Ceramic Capacitor 470P 50V	R357	OB01885A	Carbon Resistor 39K ERD-25V J	R119,120	OB01920A	Carbon Resistor 100K ERD-25V J				
C107,207	OB05660A	Mylar Capacitor 0.039μ 50V J	R364	OB05700A	Carbon Resistor 470K ERD-25V J	139,140						
C321	0T04026A	Ceramic Capacitor 330P 50V	R366,367	OB01782A	Carbon Resistor 2.7K ERD-25V J	219,220						
C325	OB09098A	SP Capacitor 470P 50V J	R369	OB01792A	Carbon Resistor 470 ERD-25V J	239,240						
C326	OB09146A	Electrolytic Capacitor 1.5μ 50V (LN)	R370	OB05673A	Carbon Resistor 5.6K ERD-25V J	R121,221	OB05567A	Carbon Resistor 33 ERD-25V J				
C327	OB09147A	Electrolytic Capacitor 3.3μ 25V (LN)	R371	OB05688A	Carbon Resistor 390 ERD-25V J	R122,222	OB05664A	Carbon Resistor 3.9K ERD-25V J				
C328	OB09144A	Electrolytic Capacitor 0.22μ 50V (LN)	R372	OB01781A	Carbon Resistor 1K ERD-25V J	R123,223	OB09195A	Metal Film Resistor 15K SN15K2E F				
C329	OB05796A	Mylar Capacitor 0.047μ 50V J	R373,374	OB05587A	Carbon Resistor 56 ERD-25V J	R124,224	OB01781A	Carbon Resistor 1K ERD-25V J				
C330	OB01502A	Electrolytic Capacitor 330μ 16V	R375	OB05947A	Fail Safe Type Resistor 56 ERD-14F J	R125,225	OB09202A	Metal Film Resistor 33 SN15K2E F				
			R378	OB05593A	Carbon Resistor 150K ERD-25V J	R126,226	OB01921A	Carbon Resistor 330K ERD-25V J				
			R389	OB05939A	Fail Safe Type Resistor 33 ERD-14F J	R127,227	OB09200A	Metal Film Resistor 22K SN15K2E F				

6.2. Power P.C.B. Ass'y

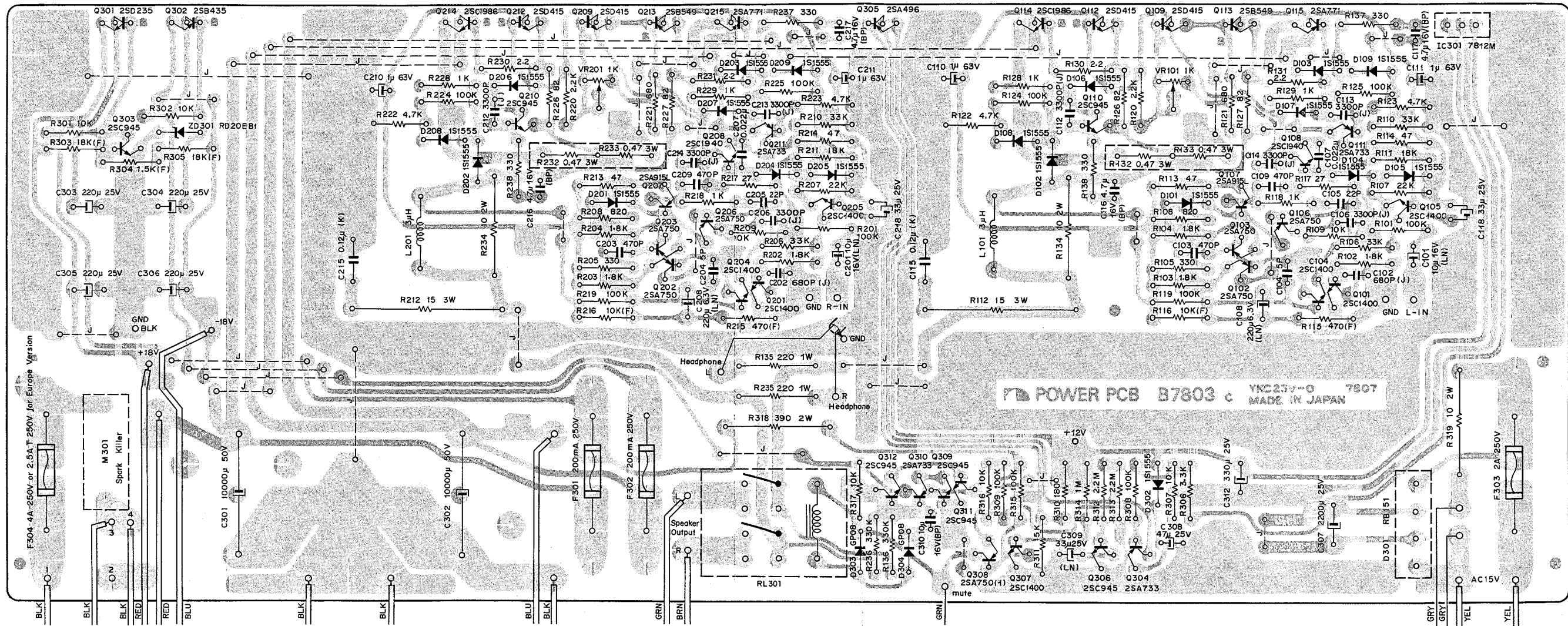

Fig. 6.2

6.3. Lamp P.C.B. Ass'y

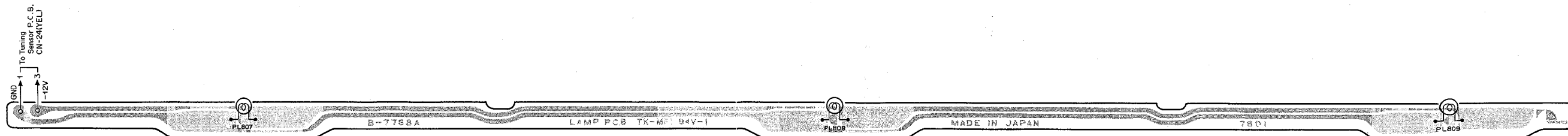

Fig. 6.3



Schematic Ref. No.	Part No.	Description	Schematic Ref. No.	Part No.	Description	Schematic Ref. No.	Part No.	Description
	BA03992A BA03997A BA03998A BA03999A BA04041A	Power P.C.B. Ass'y (U.S.A. & Canada) Power P.C.B. Ass'y (Japan) Power P.C.B. Ass'y (Sweden & Swiss) Power P.C.B. Ass'y (UK & Australia) Power P.C.B. Ass'y (Others)	R137,138 237,238 C101,201 C102,202 C103,109 203,209 C104,204 C105,205 C106,112 113,114 206,212 213,214 C107,207 C108,208 C110,111 210,211 C115,215 C116,117 216,217 C118,228	0B05577A 0B09148A 0B09238A 0B01716A 0B05905A 0B09095A 0B01914A 0B05882A 0B09151A 0B09082A 0B01772A 0B09181A 0B09150A	Carbon Resistor 330 ERD-25T J Electrolytic Capacitor 10μ 16V (LN) PP Capacitor 680P 100V K Ceramic Capacitor 470P 50V Ceramic Capacitor 5P 50V Ceramic Capacitor 22P 50V Mylar Capacitor 3300P 50V J Ceramic Capacitor 0.022μ 50V Electrolytic Capacitor 220μ 6.3V (LN) Electrolytic Capacitor 1μ 63V Mylar Capacitor 0.12μ 50V K Electrolytic Capacitor 4.7μ 16V (BP) Electrolytic Capacitor 33μ 25V			— Miscellaneous — 0B07803C Power P.C.B. 0B08342A Spark Killer (U.S.A. & Canada) 0B08363A Spark Killer (Japan) 0B08445A Spark Killer (Sweden, Swiss & Others) 0B08240A Spark Killer (UK & Australia) 0B08524A Fuse 200mA 250V (U.S.A. & Canada) 0B08517A Fuse 200mA 250V (Japan) 0B08520A Fuse 200mA 250V (Sweden, Swiss, UK, Australia & Others) 0B08525A Fuse 2A 250V (U.S.A. & Canada) 0B08518A Fuse 2A 250V (Japan) 0B08100U Fuse 2A 250V (Sweden, Swiss, UK, Australia & Others) 0B08574A Fuse 4A 125V (U.S.A., Canada & Others) 0B08138U Fuse 4A 250V (Japan) 0B08625A Fuse 2.5AT 250V (Sweden, Swiss, UK & Australia) 0M03938B Fuse Label 200mA (2 pcs.) 0M03937A Fuse Label 2A (U.S.A., Canada & Japan) (1 pce.) 0M04059A Fuse Label 2.5AT (1 pce.) (Sweden, Swiss, UK, Australia & Others) 0M03973A Fuse Label 4A 125V (1 pce.) (U.S.A. & Canada) 0M03961A Fuse Label 4A (Japan) (1 pce.) 0M03953A Fuse Caution Label B 200mA 250V (U.S.A., Canada & Japan) (1 pce.) 0M03954A Fuse Caution Label C 2A 250V (1 pce.) (U.S.A., Canada & Japan) 0M03974A Fuse Caution Label E (U.S.A. & Canada) (1 pce.) 0M03962A Fuse Caution Label 4A 250V (Japan) (1 pce.) 0B08365A Fuse Cap G7Z2 (U.S.A. & Canada) (8 pcs.) 0B08349A Fuse Clip (Japan, Sweden, Swiss, UK, Australia & Others) (8 pcs.) 0B08359A Spark Killer Cover (Sweden, Swiss & Others) (2 pcs.) 0B08628A Reinforcement Stud (Sweden & Swiss) (2 pcs.) 0B08542A Wrapping Pin 1P (8 pcs.) 0B08543A Wrapping Pin 2P (3 pcs.)
	— Power Amp. —							
Q101,104 105,201 204,205 Q102,103 106,202 203,206 Q107,207 Q108,208 Q109,209 Q110,210 Q111,211 Q112,212 Q113,213 Q114,214 Q115,215 D101-109 201-209 L101,201 VR101,201 R101,119 124,125 201,219 224,225 R102,103 104,202 203,204 R105,205 R106,110 206,210 R107,207 R108,208 R109,209 R111,211 R112,212 R113,114 213,214 R115,215 R116,216 R117,217 R118,128 129,218 228,229 R120,220 R121,221 R122,123 222,223 R126,127 226,227 R130,131 230,231 R132-133 232-233 R134,234 R135,235 R136,236	0B06078A 0B06074A 0B06102A 0B06101A 0B06104A 0B06100A 0B06013A 0B06196A 0B06197A 0B06185A 0B06186A 0B01909A 0B03784A 0B09190A 0B01889A 0B05614A 0B05577A 0B05509A 0B05615A 0B01680A 0B01888A 0B05560A 0B09180A 0B01706A 0B09204A 0B09203A 0B05875A 0B01857A 0B05622A 0B05794A 0B01846A 0B09162A 0B09212A 0B09156A 0B09179A 0B09188A 0B05627A	Transistor 2SC1400 Transistor 2SA750(1) Transistor 2SA915L Transistor 2SC1940L Transistor 2SD415 Transistor 2SC945 Transistor 2SA733 Transistor 2SD415 Transistor 2SB549 Transistor 2SC1986 Transistor 2SA771 Silicon Diode 1S1555 (18 pcs.) Output Coil Ass'y 3μH Semi-fixed Volume 1K Carbon Resistor 100K ERD-25T J Carbon Resistor 1.8K ERD-25T J Carbon Resistor 330 ERD-25T J Carbon Resistor 33K ERD-25T J Carbon Resistor 22K ERD-25T J Carbon Resistor 820 ERD-25T J Carbon Resistor 10K ERD-25T J Carbon Resistor 18K ERD-25T J Fail Safe Type Resistor 15 RSF3A J Carbon Resistor 47 ERD-25T J Metal Film Resistor 470 SN14K2E F Metal Film Resistor 10K SN14K2E F Carbon Resistor 27 ERD-25T J Carbon Resistor 1K ERD-25T J Carbon Resistor 2.2K ERD-25T J Carbon Resistor 680 ERD-25T J Carbon Resistor 4.7K ERD-25T J Fail Safe Type Resistor 82 RDF25S J Fail Safe Type Resistor 2.2 RDF25S J Metal Plate Resistor 0.47 3W Fail Safe Type Resistor 10 RSF2A J Fail Safe Type Resistor 220 RSF1B J Carbon Resistor 330K ERD-25T J	Q301 Q302 Q303 ZD301 R301,302 R303,305 R304 C301,302 C303,304 305,306 IC301 Q306,309 311,312 Q307 Q308 D301 D302 D303,304 R306 R307,316 317 R308,309 315 R310 R311 R312,313 R314 R318 R319 C307 C308 C309 C310 C312 RL301	0B01823A 0B06011A 0B06100A 0B06187A 0B01888A 0B09229A 0B09230A 0B09161A 0B01391A 0B06176A 0B06100A 0B06078A 0B06074A 0B06183A 0B01909A 0B06109A 0B01681A 0B01888A 0B01889A 0B05578A 0B01683A 0B05671A 0B05776A 0B09158A 0B09179A 0B05654A 0B01409A 0B09150A 0B09163A 0B05793A 0B07212A	Transistor 2SD235 Transistor 2SB435 Transistor 2SC945 Zener Diode RD20ZB B1 Carbon Resistor 10K ERD25T J Metal Film Resistor 18K SN14K2E F Metal Film Resistor 1.5K SN14K2E F Electrolytic Capacitor 10000μ 50V Electrolytic Capacitor 220μ 25V IC μA7812M Transistor 2SC945 Transistor 2SC1400 Transistor 2SA750 Diode Bridge RB151 Silicon Diode 1S1555 Silicon Diode GP-08 Carbon Resistor 3.3K ERD-25T J Carbon Resistor 10K ERD-25T J Carbon Resistor 100K ERD-25T J Carbon Resistor 180 ERD-25T J Carbon Resistor 15K ERD-25T J Carbon Resistor 2.2M ERD-25T J Carbon Resistor 1M ERD-25T J Fail Safe Type Resistor 390 RSF2B J Fail Safe Type Resistor 10 RSF2B J Electrolytic Capacitor 2200μ 25V Electrolytic Capacitor 47μ 25V Electrolytic Capacitor 33μ 25V (LN) Electrolytic Capacitor 10μ 16V (BP) Electrolytic Capacitor 330μ 25V Speaker Relay 24V MY4-02-US-40L			— Regulator — — Protector —
								— Lamp P.C.B. Ass'y — 0B07801A Lamp P.C.B. 0B08553A Lamp 14V 80mA

6.4. Preset Switch P.C.B. Ass'y

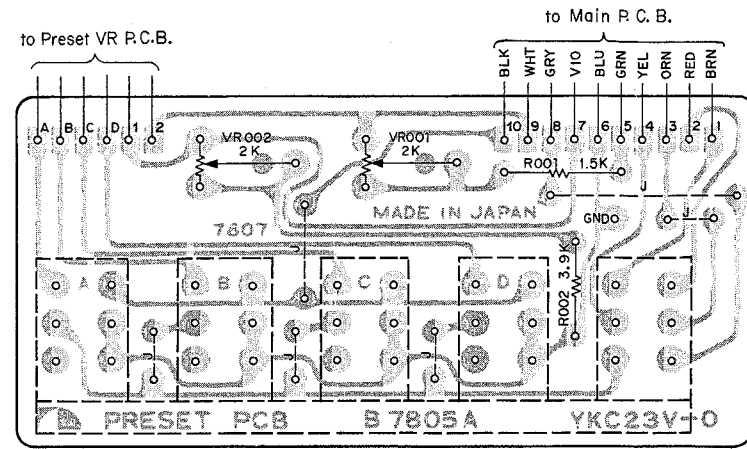

Fig. 6.4

6.6. Preset Volume P.C.B. Ass'y

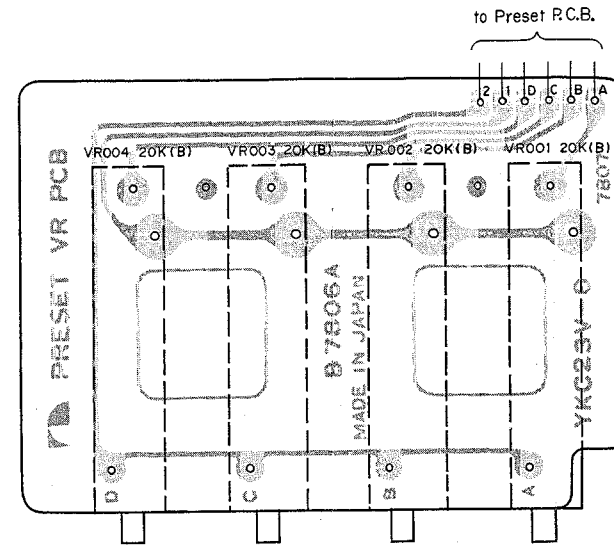

Fig. 6.6

6.7. Indicator P.C.B. Ass'y

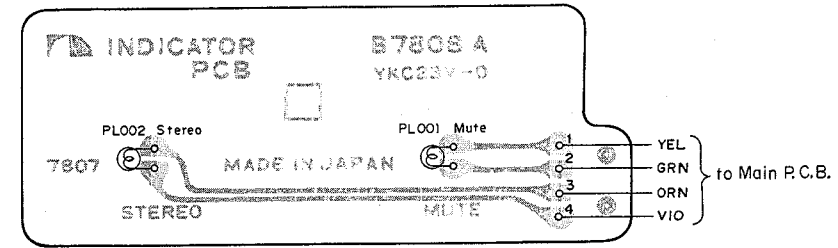

Fig. 6.7

6.5. Auto-Tuning P.C.B. Ass'y

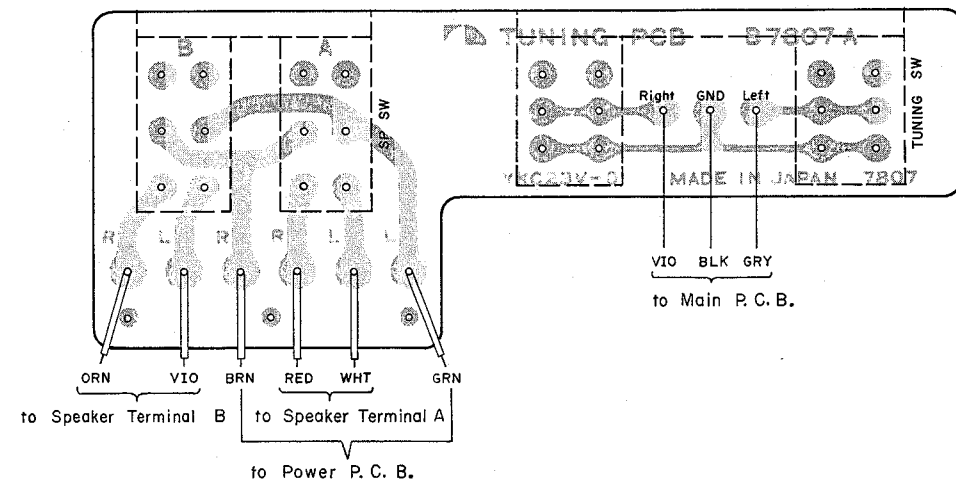

Fig. 6.5

6.8. Function P.C.B. Ass'y

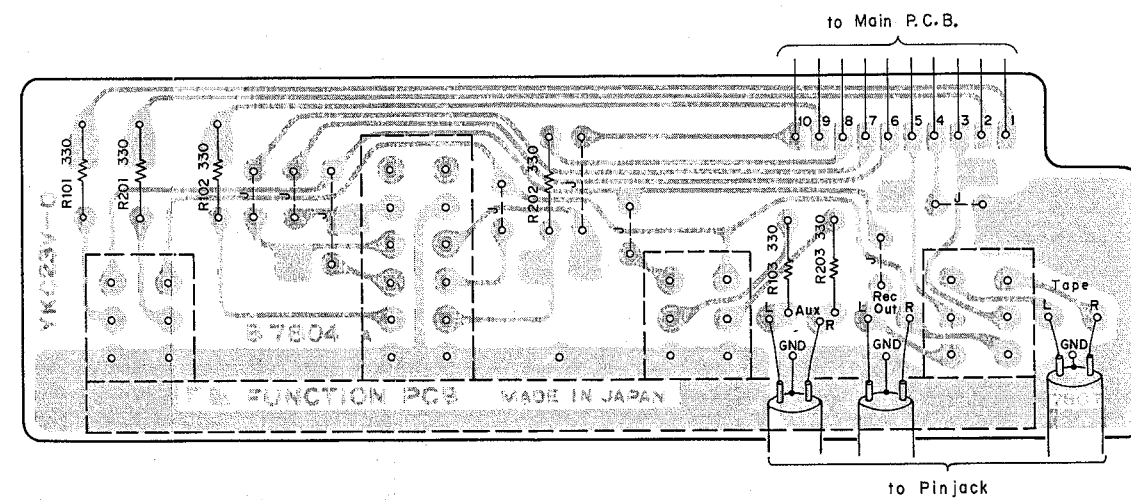

Fig. 6.8

Schematic Ref. No.	Part No.	Description	Schematic Ref. No.	Part No.	Description	Schematic Ref. No.	Part No.	Description
	BA03989A	Preset Switch P.C.B. Ass'y		BA03988A	Auto Tuning P.C.B. Ass'y		BA03996A	Indicator P.C.B. Ass'y
VR001,002 R001 R002	0B07805A	Preset Switch P.C.B.		0B07807A	Auto Tuning P.C.B.	PLO01,002	0B07808A	Indicator P.C.B.
	0B09106A	Semi-fixed Volume 2K		0B07245A	Push Switch (1 pce.)		0B08586A	Lamp T3 12V 60mA
	0B05698A	Carbon Resistor 1.5K ERD-25T J	VR001,002 003,004	0B07246A	Push Switch (1 pce.)		BA03987A	Function P.C.B. Ass'y
	0B05675A	Carbon Resistor 3.9K ERD-25T J			BA03990A	Preset Volume P.C.B. Ass'y		0B07804A
0B07244A	Push Switch (1 pce.)			0B07806A	Preset Volume P.C.B.	R101,102 103,201 202,203	0B05577A	Carbon Resistor 330 ERD-25T J
0B05230A	Flat Cable (1 pce.)		0B07214A	Volume 20K (B)			0B07243A	Push Switch (1 pce.)

7. MECHANISM ASS'Y AND PARTS LIST

7.1. Synthesis

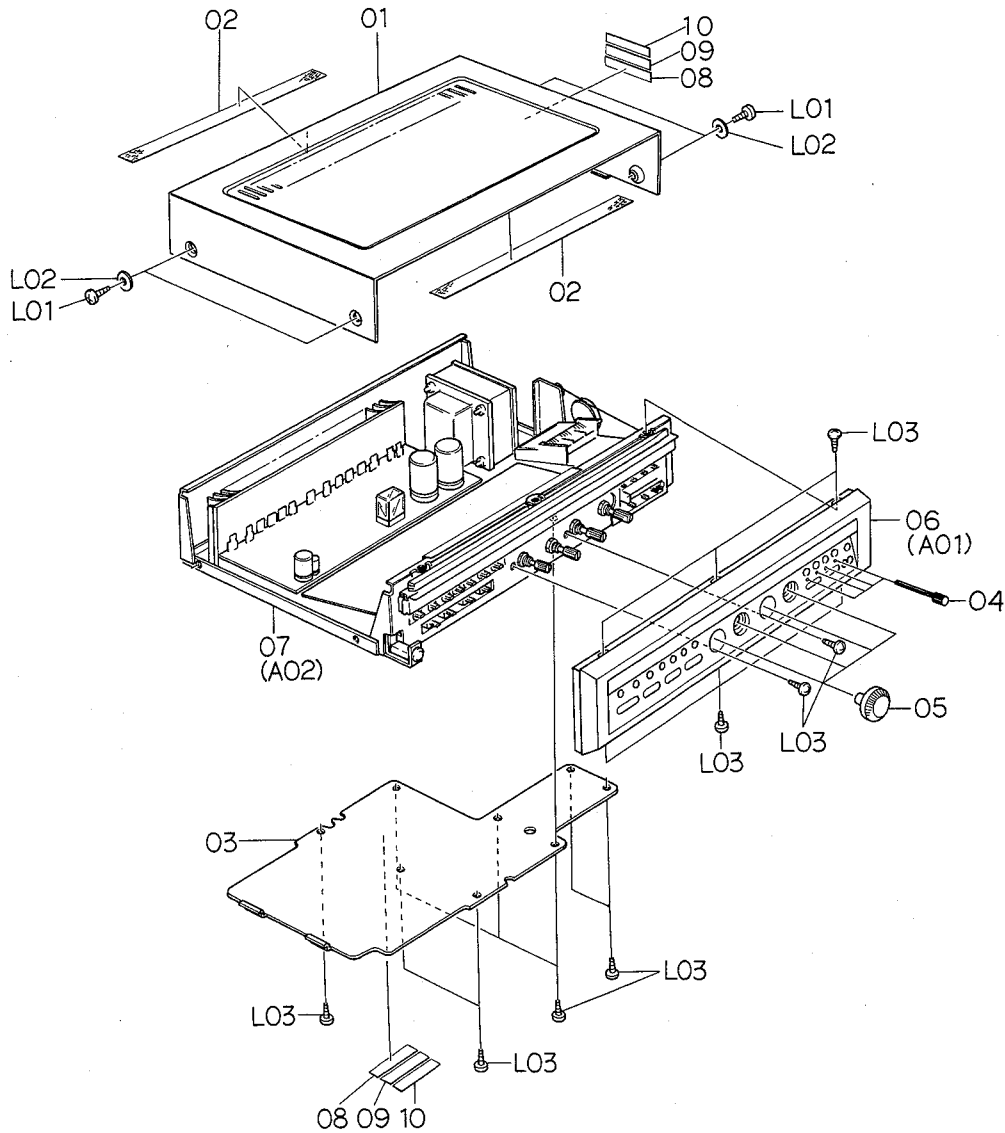

Fig. 7.1

Schematic Ref. No.	Part No.	Description	Q'ty	Schematic Ref. No.	Part No.	Description	Q'ty
		<b>Synthesis</b>			JA03358A	Synthesis Mechanism 530 (UK)	1
					JA03360A	Synthesis Mechanism 530 (Others)	1
01	0H03681C	Top Cover	1	08	0M03799A	Caution Label G	2
02	0J03580B	Top Cover Himeion	2	09	0M03800A	Caution Label H (U.S.A. & Canada)	2
03	0J03941C	Bottom Cover	1	10	0M03883A	Lamp Caution Label (U.S.A. & Canada)	2
04	0H03677C	Preset Volume Knob	4	L01	0E00858A	BT Screw M4x6	4
05	0H03706A	Volume Knob	4	L02	0E00736A	Philips Binding Head (Black) Washer 4mm (Black)	4
06	HA03769A	Front Panel Ass'y	1	L03	0E00857A	BT Screw M3x6 Philips Binding Head	16
07	JA03353A	Synthesis Mechanism 530 (U.S.A. & Canada)	1				
	JA03354A	Synthesis Mechanism 530 (Japan)	1				
	JA03355A	Synthesis Mechanism 530 (Sweden)	1				
	JA03356A	Synthesis Mechanism 530 (Swiss)	1				
	JA03357A	Synthesis Mechanism 530 (Australia)	1				

7.2. Front Panel Ass'y (A01)

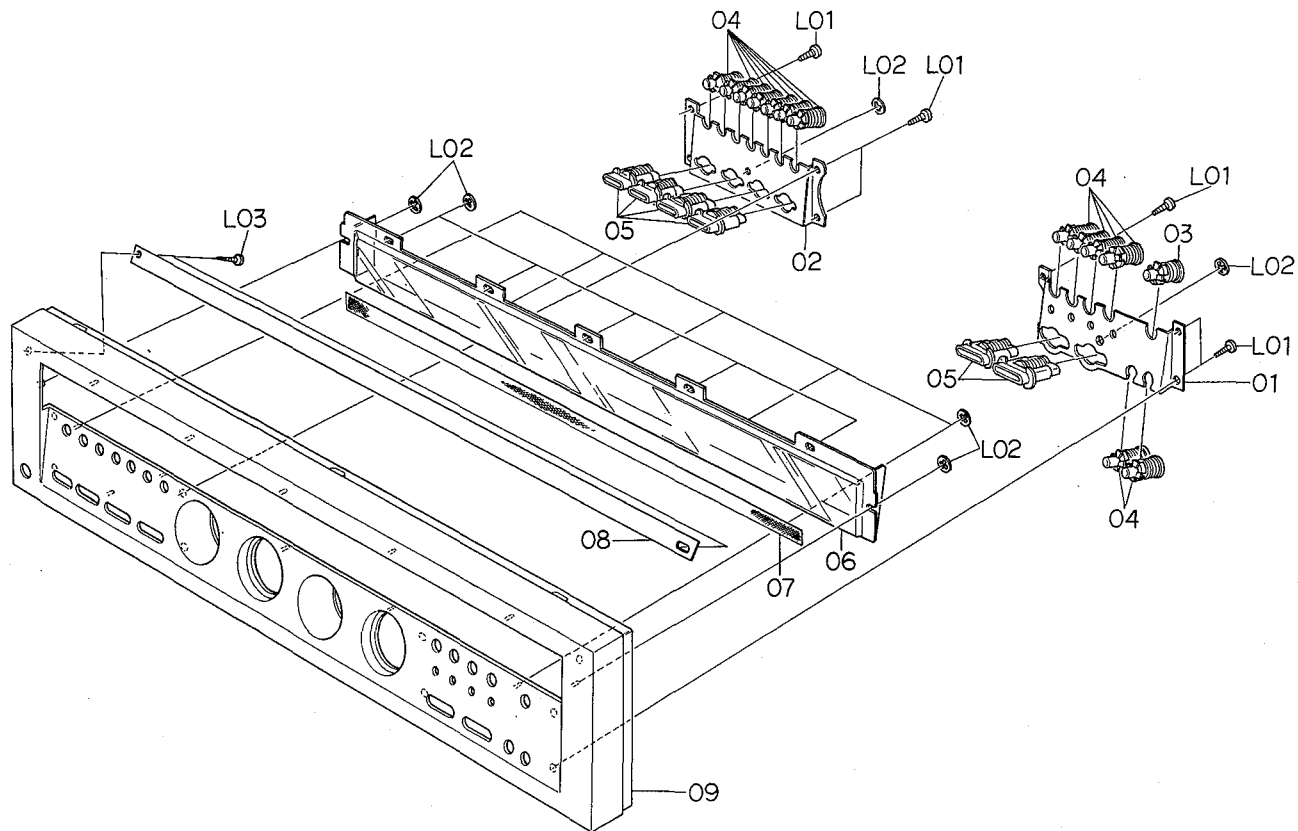

Fig. 7.2

Schematic Ref. No.	Part No.	Description	Q'ty
A01	HA03769A	Front Panel Ass'y	1
01	OJ03980C	Button Holder A	1
02	OJ03981B	Button Holder B	1
03	HA03807A	Push Button Ass'y A	1
04	HA03808A	Push Button Ass'y B	13
05	HA03809A	Push Button Ass'y C	1
06	OH03671C	Acrylic Cover	1
07	OJ03997A	Himelon B	1
08	OH03685A	Aluminum Mirror	1
09	OH03670C	Front Panel	1
L01	0E00859A	BT Screw M2.6x6 Philips Binding Head	8
L02	0E00252A	Stopper Ring CS 3mm	14
L03	0E00855A	BT Screw M2x6 Philips Binding Head	2

7.3. Synthesis Mechanism 530 (A02)

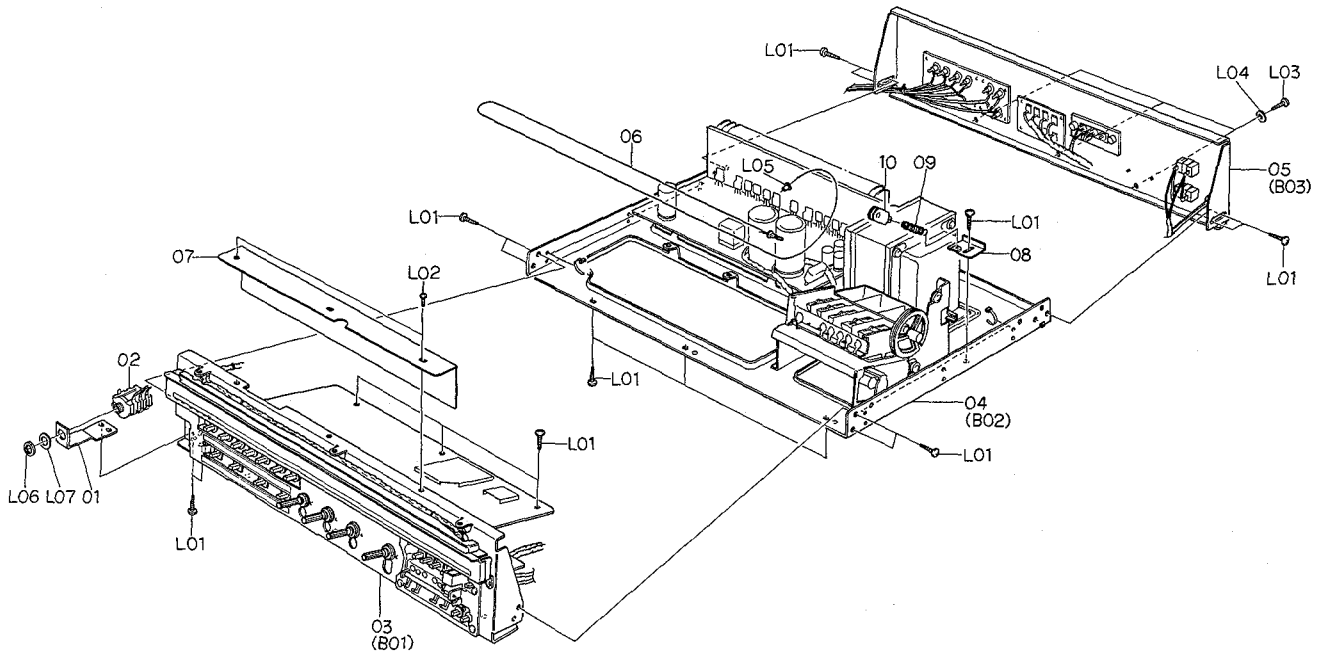

Fig. 7.3

Schematic Ref. No.	Part No.	Description	Q'ty	Schematic Ref. No.	Part No.	Description	Q'ty
A02	JA03353A	Synthesis Mechanism 530 (U.S.A. & Canada)	1	05	JA03369A	Rear Panel Ass'y (U.S.A. & Canada)	1
	JA03354A	Synthesis Mechanism 530 (Japan)	1		JA03370A	Rear Panel Ass'y (Japan)	1
	JA03355A	Synthesis Mechanism 530 (Sweden)	1		JA03371A	Rear Panel Ass'y (Sweden)	1
	JA03356A	Synthesis Mechanism 530 (Swiss)	1		JA03372A	Rear Panel Ass'y (Swiss)	1
	JA03357A	Synthesis Mechanism 530 (Australia)	1		JA03373A	Rear Panel Ass'y (Australia)	1
	JA03358A	Synthesis Mechanism 530 (UK)	1		JA03374A	Rear Panel Ass'y (UK)	1
	JA03360A	Synthesis Mechanism 530 (Others)	1		JA03375A	Rear Panel Ass'y (Others)	1
01	0J03955B	Headphone Jack Holder	1	06	JA03377A	Dial Thread Ass'y 530	1
02	0B08511A	Headphone Jack	1	07	0H03700B	Light Intercepting Plate	1
03	JA03362A	Front Chassis Ass'y (U.S.A. & Canada)	1	08	0J03950A	Pulley Spring Holder	1
	JA03363A	Front Chassis Ass'y (Japan)	1	09	0J03984A	Pulley Spring	1
	JA03364A	Front Chassis Ass'y (Sweden, Swiss, UK, Australia & Others)	1	10	JA03378A	Pulley Holder C Ass'y	1
04	JA03365A	Main Chassis Ass'y (U.S.A. & Canada)	1	L01	0E00857A	BT Screw M3x6	17
	JA03366A	Main Chassis Ass'y (Japan)	1	L02	0E00841A	BT Screw M2x4 Philips Pan Head	2
	JA03399A	Main Chassis Ass'y (Sweden & Swiss)	1	L03	0E00860A	BT Screw M3x6	3
	JA03367A	Main Chassis Ass'y (UK)	1	L04	0E00157A	Philips Binding Head (Black)	3
	JA03400A	Main Chassis Ass'y (Australia)	1	L05	0E00752A	Washer 3mm (Black Plastics)	3
	JA03368A	Main Chassis Ass'y (Others)	1	L06	-	Thread Guide	1
				L07	-	Headphone Jack Nut	(1)
				-	0B08515A	Headphone Jack Washer	(1)
						Insu-Lock	12

7.4. Front Chassis Ass'y (B01)

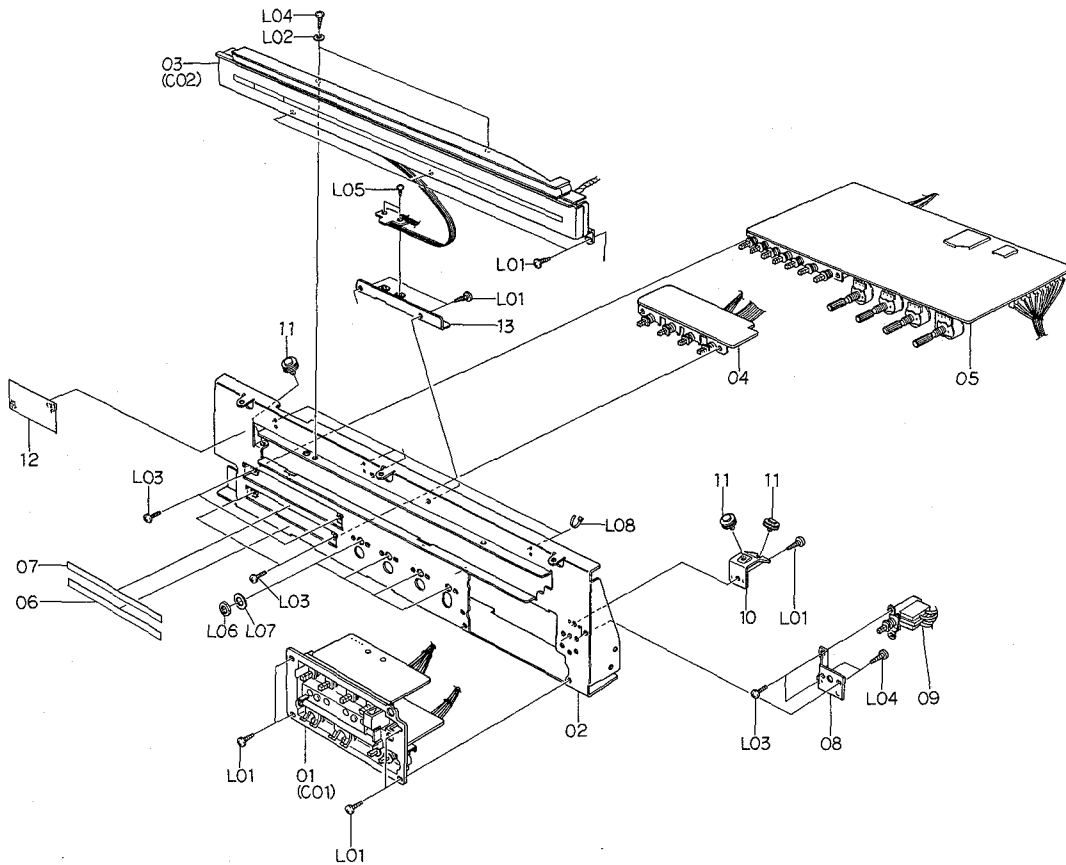

Fig. 7.4

Schematic Ref. No.	Part No.	Description	Q'ty	Schematic Ref. No.	Part No.	Description	Q'ty	
B01	JA03362A	Front Chassis Ass'y (U.S.A. & Canada)	1	L02	0E00157A	Washer 3mm (Black Plastics)	2	
	JA03363A	Front Chassis Ass'y (Japan)	1	L03	0E00509A	Screw M3x6 Philips Pan Head	6	
	JA03364A	Front Chassis Ass'y (Sweden, Swiss, UK, Australia & Others)	1	L04	0E00862A	BT Screw M3x6 Philips Pan Head	4	
				L05	0E00841A	BT Screw M2x4 Philips Pan Head	2	
				L06	-	Volume Nut	(4)	
				L07	-	Volume Washer	(4)	
				L08	0B08515A	Insu-Lock	3	
01	JA03381A	Tuning Control Switch Ass'y	1	B02	JA03365A	Main Chassis Ass'y (U.S.A. & Canada)	1	
02	0J03940J	Front Chassis	1		JA03366A	Main Chassis Ass'y (Japan)	1	
03	JA03379A	Scale Holder Ass'y (Overseas)	1		JA03367A	Main Chassis Ass'y (UK)	1	
	JA03380A	Scale Holder Ass'y (Japan)	1		JA03368A	Main Chassis Ass'y (Others)	1	
04	BA03987A	Function P.C.B. Ass'y	1		JA03399A	Main Chassis Ass'y (Sweden & Swiss)	1	
05	BA03981A	Main P.C.B. Ass'y (50 μs)	1		JA03400A	Main Chassis Ass'y (Australia)	1	
	BA04056A	Main P.C.B. Ass'y (75 μs)	1					
	BA04057A	Main P.C.B. Ass'y (75 μs/50 μs)	1		01	0J03939F	Main Chassis 530	1
06	0M03979A	Function Switch Label	1		02	0B06600C	Power Transformer (U.S.A. & Canada)	1
07	0M03978A	Push Switch Label	1			0B06599C	Power Transformer (Japan)	1
08	0J03958B	Power Switch Holder	1		0B06601A	Power Transformer (Sweden, Swiss & UK)	1	
09	0B07251A	Power Switch (U.S.A. & Canada)	1		0B06602B	Power Transformer (Australia & Others)	1	
	0B07271A	Power Switch (Japan)	1					
	0B07252A	Power Switch (Sweden, Swiss, UK, Australia & Others)	1	03	JA03401A	Power Block Ass'y (U.S.A. & Canada)	1	
10	0J03944A	Pulley Holder A	1					
11	JA03315A	Pulley Ass'y 730	3					
12	0J03992A	Himelon A	1					
13	0J03949A	P.C.B. Holder	1					
L01	0E00857A	BT Screw M3x6 Philips Binding Head	10					

7.5. Main Chassis Ass'y (B02)

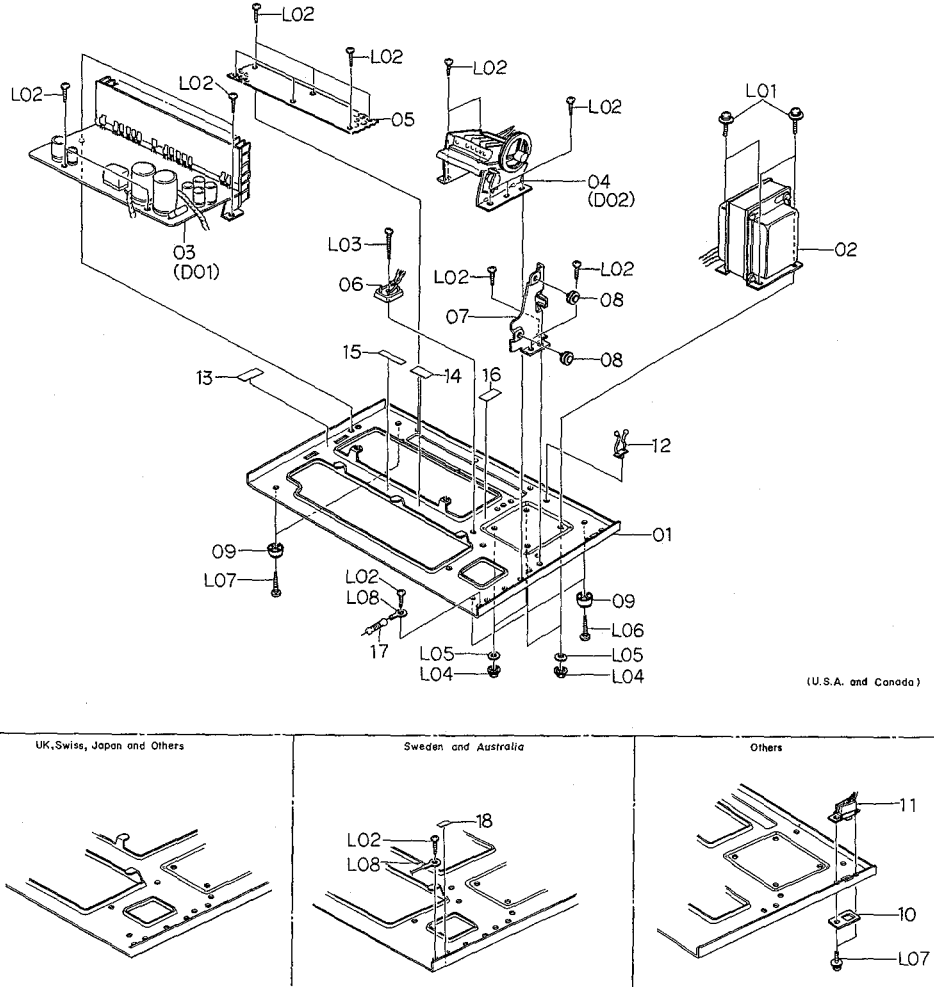

Fig. 7.5

Schematic Ref. No.	Part No.	Description	Q'ty	Schematic Ref. No.	Part No.	Description	Q'ty
04	JA03402A	Power Block Ass'y (Japan)	1	15	0M03953A	Fuse Caution Label B ½ (U.S.A. & Canada)	1
	JA03403A	Power Block Ass'y (Sweden & Swiss)	1		0M03962A	Fuse Caution Label D (U.S.A. & Canada)	1
05	JA03404A	Power Block Ass'y (UK & Australia)	1	16	0B05928A	Metal Film Resistor 3.9M ERO-50CK G (U.S.A. & Canada)	1
	JA03546A	Power Block Ass'y (Others)	1		0M03700A	Ground Label (Sweden & Australia)	1
06	JA03383A	Front-end Holder Ass'y (Overseas)	1	17	0E00849A	Screw M5x12 Philips Pan Head	4
	JA03384A	Front-end Holder Ass'y (Japan)	1		*L02	0E00857A	BT Screw M3x6 Philips Binding Head
07	OJ03959A	Punching Plate	1	L03	0E00870A	BT Screw M3x14 Philips Binding Head	1
	0B06108A	Diode Bridge S5VB-20	1		L04	0E00850A	Nut Hex. M5
08	OJ03945A	Pulley Holder B	1	L05	0E00864A	Washer 6mm	4
	JA03315A	Pulley Ass'y 730	2		L06	0E00852A	BT Screw Philips Binding Head
09	OJ03825A	Leg S	4	*L07	0E00606A	Screw M3x6 Philips Pan Head (3A)	2
	0M03945A	Voltage Selector Lock Plate (Others)	1		*L08	0E00037A	Earth Lug B-5
10	0B07250A	Voltage Selector (Others)	1				
11	0B08573A	Wire Holder 249	1				
12	0M03954A	Fuse Caution Label C (U.S.A. & Canada)	1				
13	0M03953A	Fuse Caution Label B ½ (U.S.A. & Canada)	1				

\*: Quantity will depend on each version.

7.6. Rear Panel Ass'y (B03)

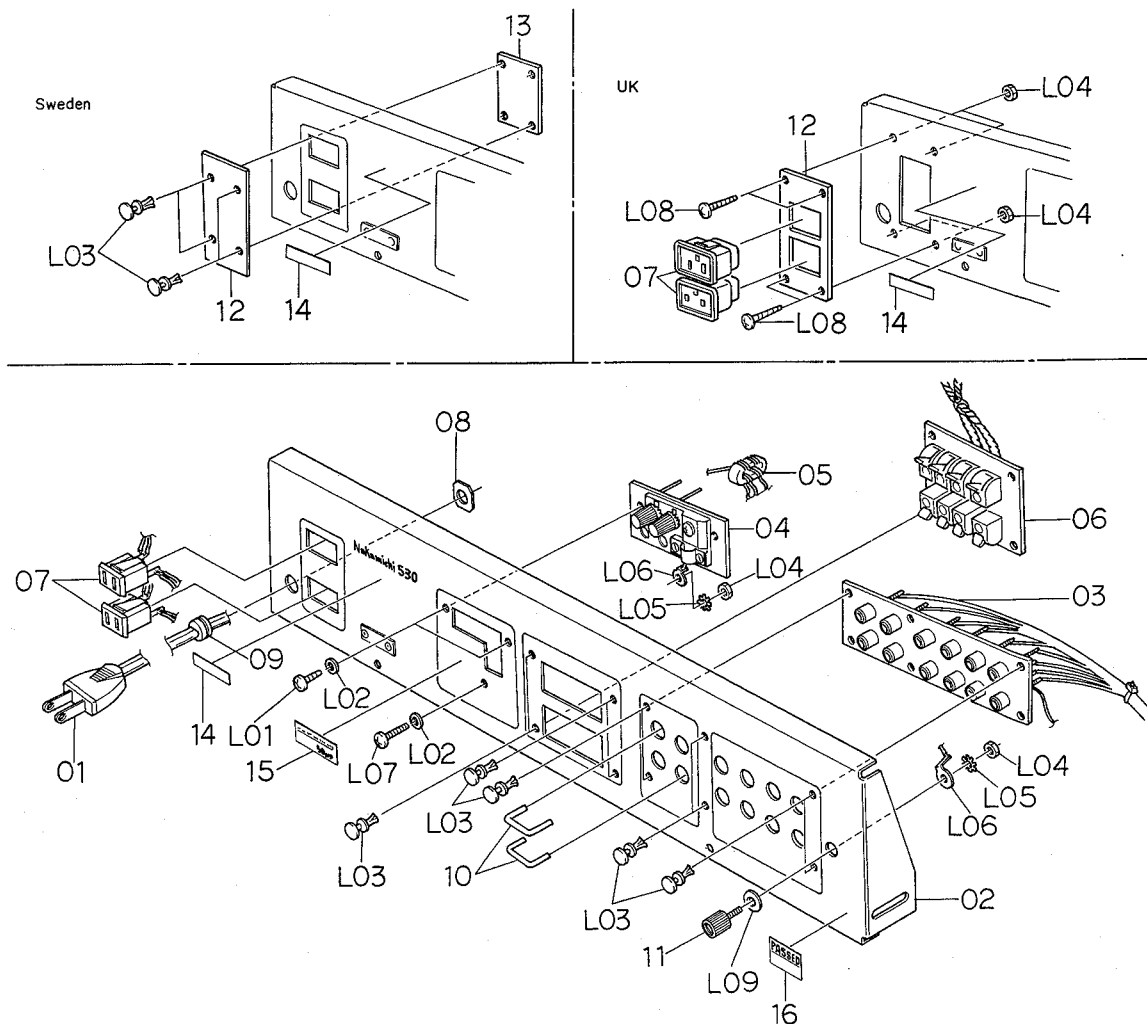

Fig. 7.6

Schematic Ref. No.	Part No.	Description	Q'ty	Schematic Ref. No.	Part No.	Description	Q'ty
B03	JA03369A	Rear Panel Ass'y (U.S.A. & Canada)	1	06	0B08564A	Speaker Terminal	1
	JA03370A	Rear Panel Ass'y (Japan)	1	07	0B08510A	AC Outlet (U.S.A., Canada, Japan, Swiss, Australia & Others)	2
	JA03371A	Rear Panel Ass'y (Sweden)	1		0B08352A	AC Outlet (UK)	2
	JA03372A	Rear Panel Ass'y (Swiss)	1	08	0A03154B	Cord Spacer	1
	JA03373A	Rear Panel Ass'y (Australia)	1	09	0B08037U	Cord Bushing C (U.S.A., Canada, Japan, Swiss & Others)	1
	JA03374A	Rear Panel Ass'y (UK)	1		0B08325U	Cord Bushing E (Sweden & Australia)	1
	JA03375A	Rear Panel Ass'y (Others)	1		0B08351A	Cord Bushing 4K-4 (UK)	1
01	0B08533A	Power Cord (U.S.A., Canada & Others)	1	10	0B08572A	Pre-Main Connection Pin	2
	0B08219B	Power Cord (Japan)	1	11	0B03920B	Ground Terminal	1
	0B08149U	Power Cord (Sweden)	1	12	0J04000A	Outlet Cover (Sweden)	1
	0B08093U	Power Cord (Swiss)	1		0J04001A	Outlet Plate (UK)	1
	0B08666A	Power Cord (Australia)	1	13	0J03999A	Cover Plate (Sweden)	1
	0B08348A	Power Cord (UK)	1	14	0M03794A	Voltage Seal 100V (Japan)	1
02	0J03942E	Rear Panel (Except UK)	1		0M03796A	Voltage Seal 220V (Sweden & Swiss)	1
	0J03987B	Rear Panel (UK)	1		0M03797A	Voltage Seal 240V (UK & Australia)	1
03	0B08561B	12P Pin Jack	1				
04	0B08563A	Antenna Terminal	1				
05	0B06558A	Balun Transformer	1				



7.7. Tuning Control Switch (C01)

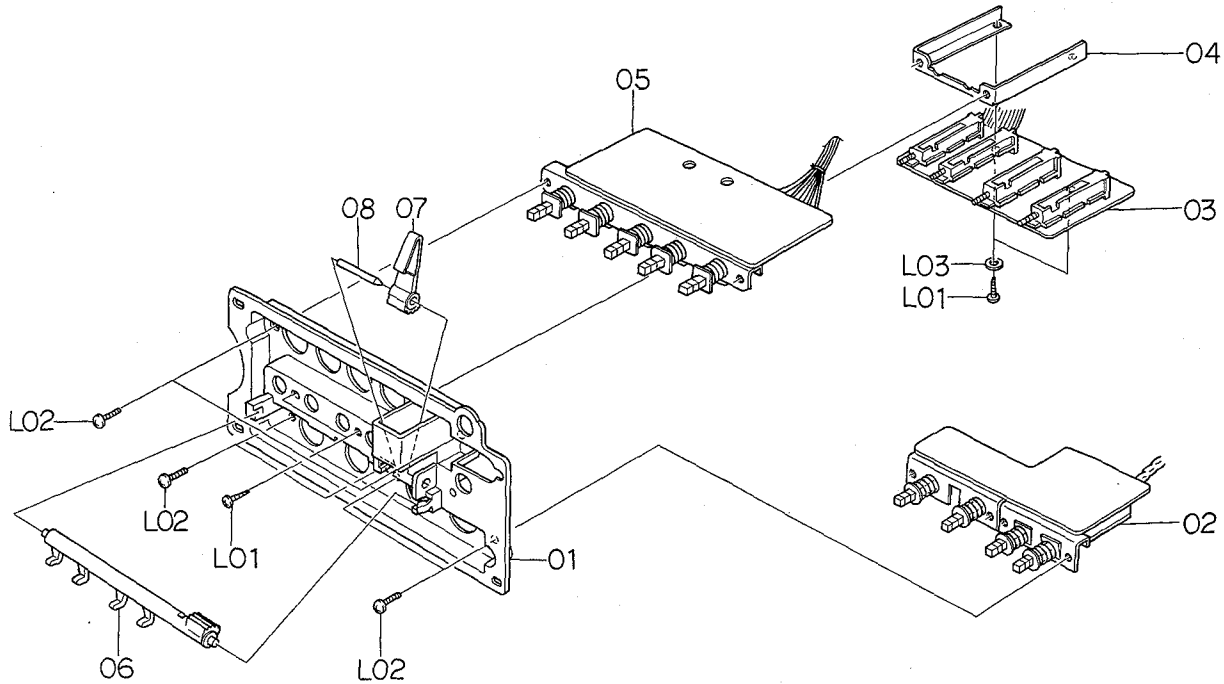

Fig. 7.7

Schematic Ref. No.	Part No.	Description	Q'ty	Schematic Ref. No.	Part No.	Description	Q'ty
	0M03955A	Voltage Seal 120V/220-240V (Others)	1	<b>C01</b>	<b>JA03381A</b>	<b>Tuning Control Switch Ass'y</b>	<b>1</b>
15	0M03769A	De-emphasis Seal 75µs (U.S.A. & Canada)	1	01	0J03934D	Control Switch Holder	1
	0M03770A	De-emphasis Seal 50µs (Except U.S.A. & Canada)	1	02	BA03988A	Auto Tuning P.C.B. Ass'y	1
16	0M03551A	Pass Label	1	03	BA03990A	Preset Volume P.C.B. Ass'y	1
-	0M03704A	Outlet Label (U.S.A. & Canada)	1	04	0J03951B	Preset Volume P.C.B. Holder	1
-	0M03959A	File No. Label B (U.S.A. & Canada)	1	05	BA03989A	Preset Switch P.C.B. Ass'y	1
-	0M03798A	Nakamichi Label (Japan)	1	06	0J03978D	Lever B	1
-	0M03844A	Power Cord Label (UK)	1	07	0J03937A	Lever A	1
-	0M03960A	Serial Number Plate	1	08	0J03960A	Lever A Shaft	1
-	0F01071A	Free-up Belt	1	L01	0E00855A	BT Screw M2x6	4
-	0M03705A	Power Cord Label (Australia)	1	L02	0E00509A	Screw M3x6 Philips Pan Head	6
L01	0E00860A	BT Screw M3x6	2	L03	0E00779A	Washer 2mm (Bakeelite)	2
		Philips Binding Head (Black)					
L02	0E00157A	Washer 3mm (Black Plastics)	3				
*L03	0B08539A	Plastic Rivet	14				
*L04	0E00507A	Nut Hex. M3	6				
L05	0E00172A	Washer 3mm Toothed Lock	2				
L06	0E00037A	Earth Lug B-5	2				
L07	0E00594A	Screw M3x8	1				
		Philips Binding Head (Bronze)					
L08	0E00875A	ST Screw M3x8	1				
		Philips Binding Head (Black)					
L09	0E00732A	Washer 3mm	1				
-	0J03644A	Chobert Rivet	2				
		*: Quantity will depend on each version.					

7.8. Scale Holder Ass'y (C02)

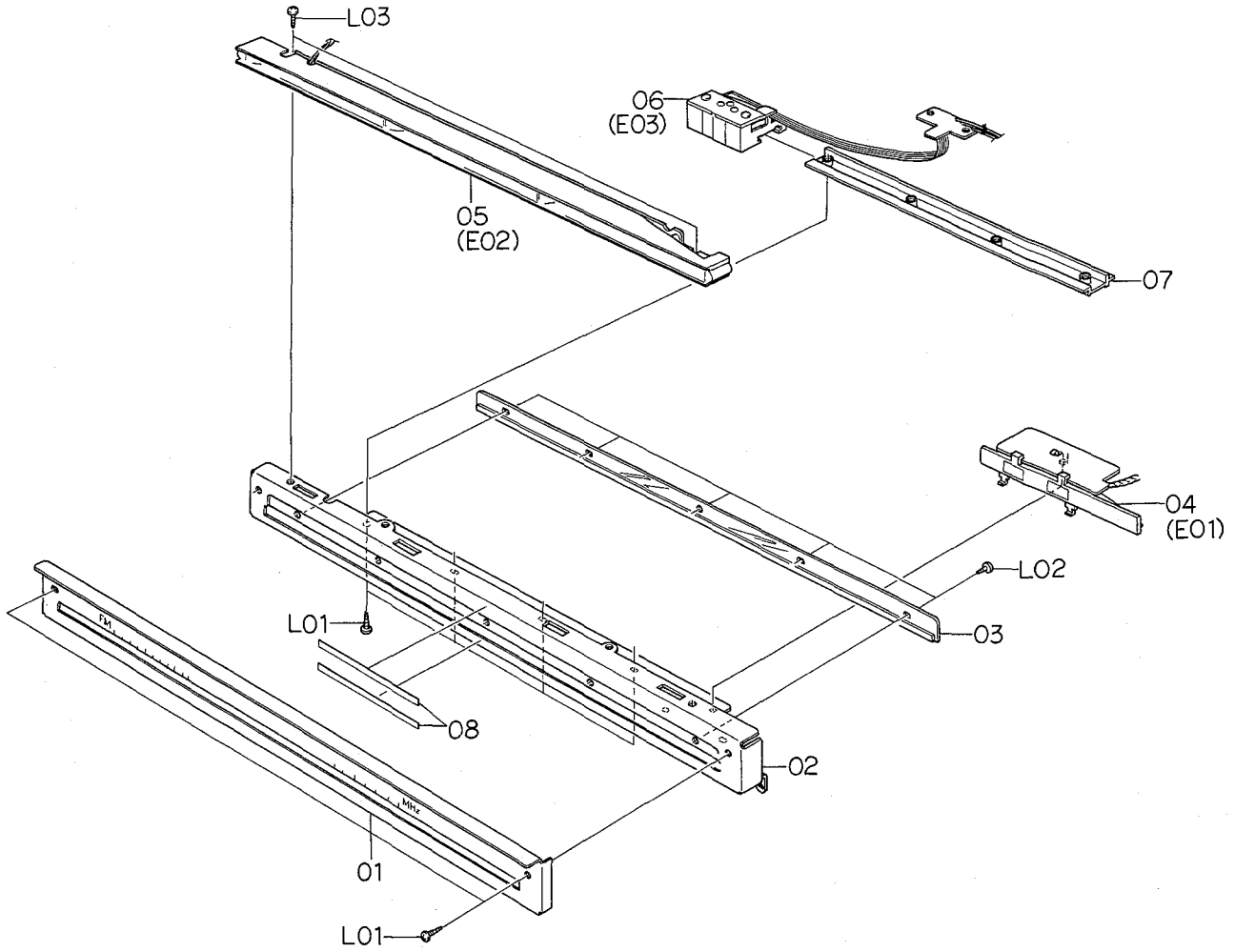

Fig. 7.8

Schematic Ref. No.	Part No.	Description	Q'ty
C02	JA03379A	Scale Holder Ass'y (Overseas)	1
	JA03380A	Scale Holder Ass'y (Japan)	1
01	0H03683C	Scale Plate (Overseas)	1
	0H03687A	Scale Plate (Japan)	1
02	0H03682C	Scale Holder	1
03	0H03672A	Acrylic Cover	1
04	HA03772A	Lamp Case Ass'y	1
05	HA03783A	Lamp House Cover Ass'y	1
06	HA03773A	Lamp Base Ass'y	1
07	0J03802B	Guide Rail	1
08	0J03998A	Adhesive Tape A	2
L01	0E00863A	BT Screw M2x5 Philips Pan Head	6
L02	0E00790A	ST Screw M2x3 Philips Pan Head	5
L03	0E00841A	BT Screw M2x4 Philips Pan Head	2

7.9. Power Block Ass'y (D01)

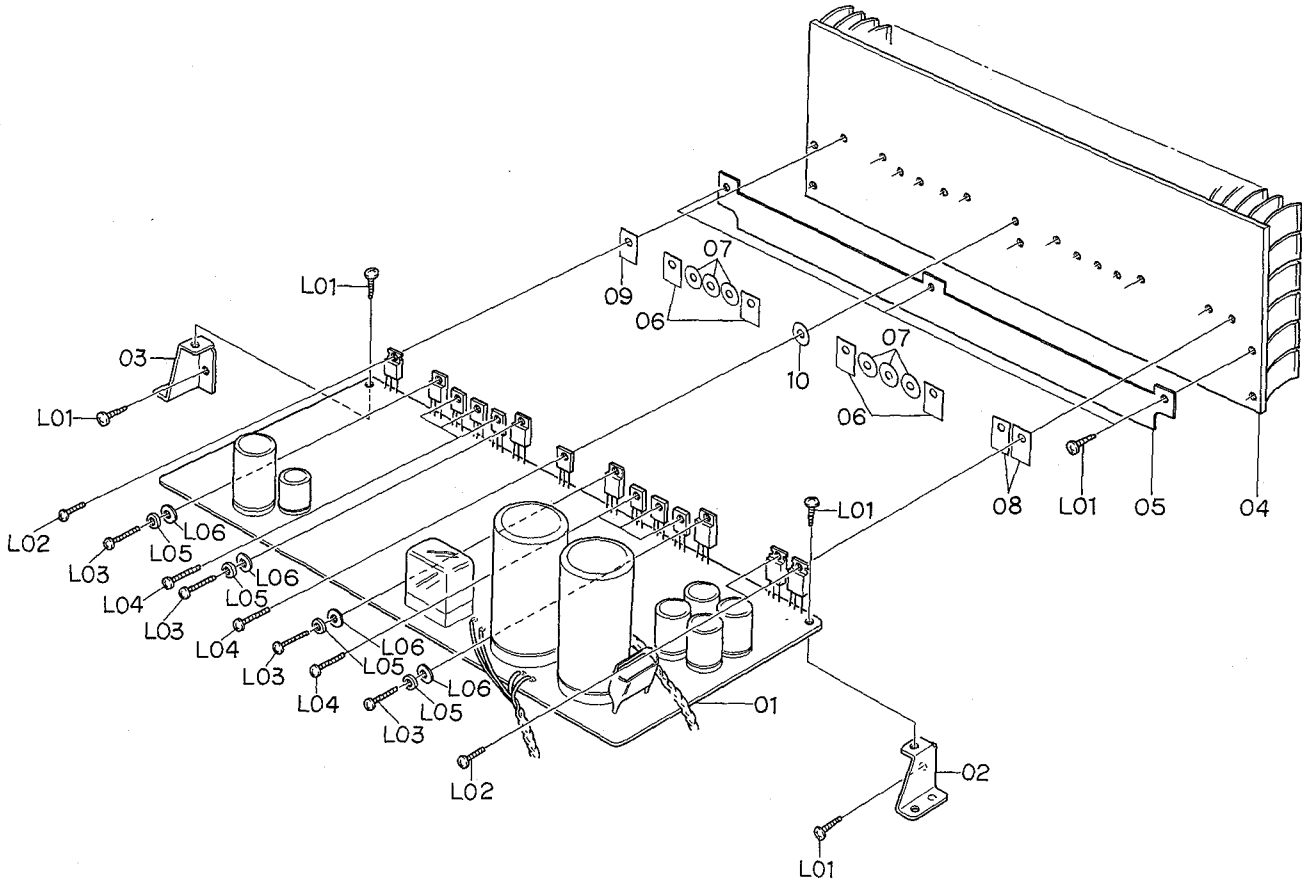

Fig. 7.9

Schematic Ref. No.	Part No.	Description	Q'ty	Schematic Ref. No.	Part No.	Description	Q'ty
D01	JA03401A	Power Block Ass'y (U.S.A. & Canada)	1	10	0B08598A	Transistor Insulator TO-126	1
	JA03402A	Power Block Ass'y (Japan)	1	L01	0E00857A	BT Screw M3x6	7
	JA03403A	Power Block Ass'y (Sweden & Swiss)	1	L02	0E00757A	Screw M3x6 Philips Pan Head (Plastics)	3
	JA03404A	Power Block Ass'y (UK & Australia)	1	L03	0E00818A	Screw M3x8 Philips Binding Head	4
	JA03546A	Power Block Ass'y (Others)	1	L04	0E00521A	Screw M3x8 Philips Pan Head	7
01	BA03992A	Power P.C.B. Ass'y (U.S.A. & Canada)	1	L05	0B08600A	Transistor Bush TO-220	4
	BA03997A	Power P.C.B. Ass'y (Japan)	1	L06	0E00183A	Washer 3.5mm	4
	BA03998A	Power P.C.B. Ass'y (Sweden & Swiss)	1				
	BA03999A	Power P.C.B. Ass'y (UK & Australia)	1				
	BA04041A	Power P.C.B. Ass'y (Others)	1				
02	OJ03948A	Power P.C.B. Holder R	1				
03	OJ03947A	Power P.C.B. Holder L	1				
04	0B08562A	Heat Sink	1				
05	OJ03988A	Power P.C.B. Insulator	1				
06	0B08599A	Transistor Insulator TO-220	4				
07	0B08595A	Transistor Insulator TO-126	6				
08	0B08601A	Transistor Insulator TO-220	2				
09	0B08603A	Transistor Insulator TO-220	1				

7.10. Front-end Holder Ass'y (D02)

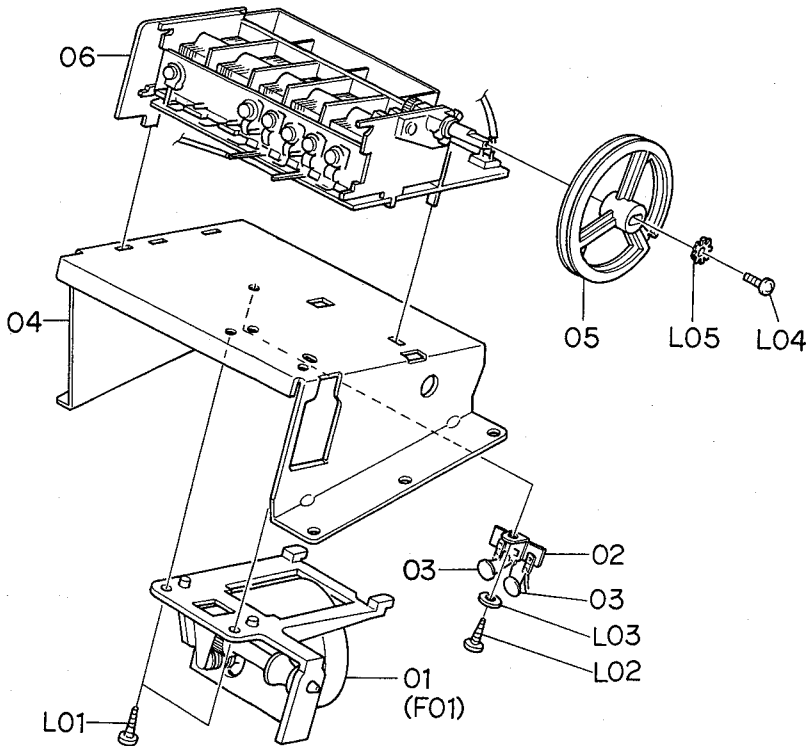

Fig. 7.10

7.11. Lamp Case Ass'y (E01)

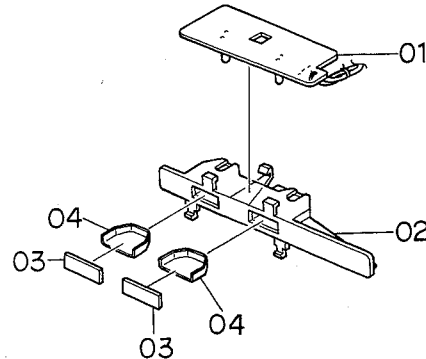

Fig. 7.11

Schematic Ref. No.	Part No.	Description	Q'ty	Schematic Ref. No.	Part No.	Description	Q'ty
D02	JA03383A	Front-end Holder Ass'y (Overseas)	1	E02	HA03783A	Lamp House Cover Ass'y	1
	JA03384A	Front-end Holder Ass'y (Japan)	1	01	BA04001A	Lamp P.C.B. Ass'y	1
01	JA03386A	Motor Base Ass'y	1	02	0H03673A	Lamp House Cover	1
02	0B04042A	Lug Terminal 1L2P	1	03	0H03674D	Lamp House	3
03	0B09290A	Ceramic Capacitor 0.01μ 50V	2	L01	0E00793A	BT Screw M2x6 Philips Pan Head	4
04	0J03943C	Front-end Holder	1	E03	HA03773A	Lamp Base Ass'y	1
05	0J03935B	Front-end Pulley	1		01	0H03613C	Lamp Base
06	0B08559A	Front-end (Overseas)	1	02	0H03615C	Lamp House	1
L01	0B08560A	Front-end (Japan)	1	03	0H03616A	Orange Lens	1
	0E00857A	BT Screw M3x6 Philips Binding Head	2	04	0H03614B	Green Lens	1
L02	0E00856A	BT Screw M3x5 Philips Binding Head	1	05	0B07781B	Turning Lamp P.C.B.	1
	0E00732A	Washer 3mm	1	06	0B08586A	Lamp T3 12V 60mA	3
L03	0E00791A	Screw M2.6x5 Philips Binding Head	1	07	0J03809A	Wire Stopper	1
L04	0E00791A	Screw M2.6x5 Philips Binding Head	1	08	0J03865A	Lamp P.C.B. Cover	1
	0E00233A	Washer 2.6mm Toothed Lock	1	L01	0E00793A	BT Screw M2x6 Philips Pan Head	2
E01	HA03772A	Lamp Case Ass'y	1	F01	JA03386A	Motor Base Ass'y	1
	01	BA03996A	Indicator P.C.B. Ass'y	1	01	JA03387A	Motor Ass'y
02	0H03675C	Lamp Case	1	02	0J03936A	Motor Base	1
03	0H03624B	Green Filter	2	03	0J03855B	Motor Spring	1
04	0H03684A	Reflector	2	04	0J03963A	Shaft	1
				05	0J03954A	Gear	1
				06	0M03902A	Motor Label 730	
				L01	0E00866A	Screw M2.6x4 Philips Binding Head	2
				L02	0E00233A	Washer 2.6mm Toothed Lock	2

7.12. Lamp House Cover Ass'y (E02)

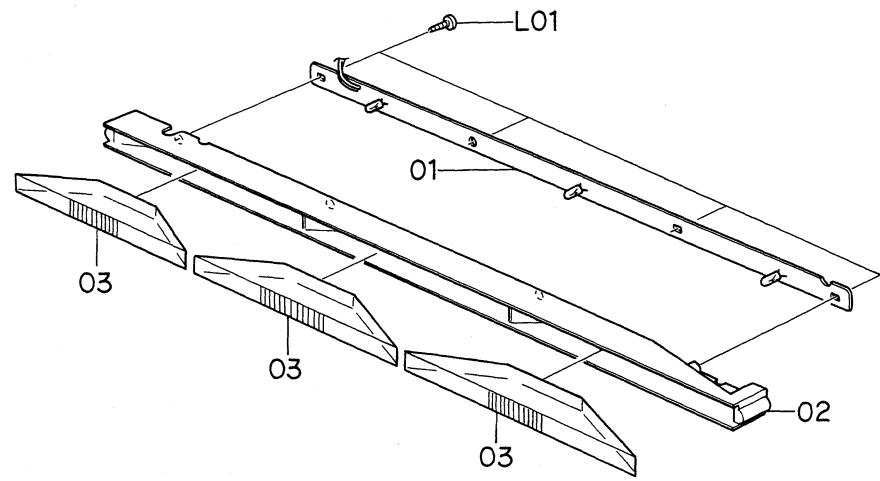

Fig. 7.12

7.14. Motor Base Ass'y (F01)

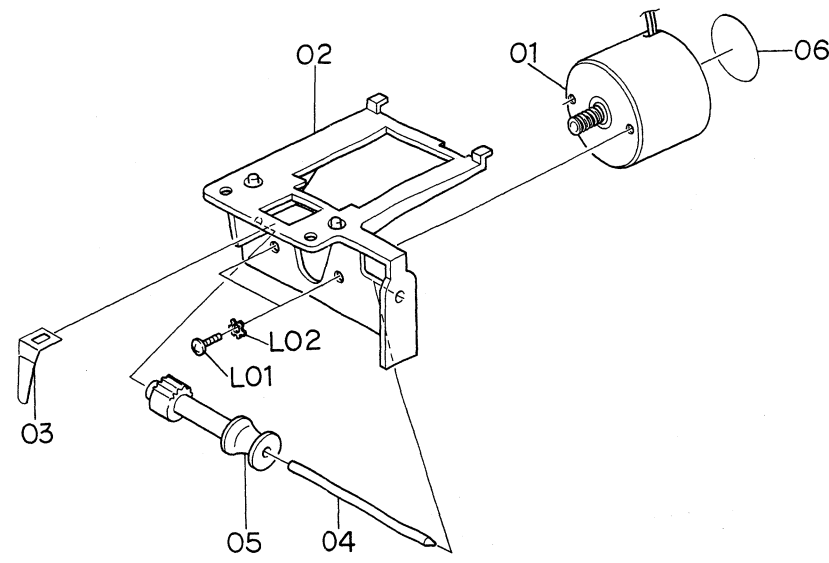

Fig. 7.14

7.13. Lamp Base Ass'y (E03)

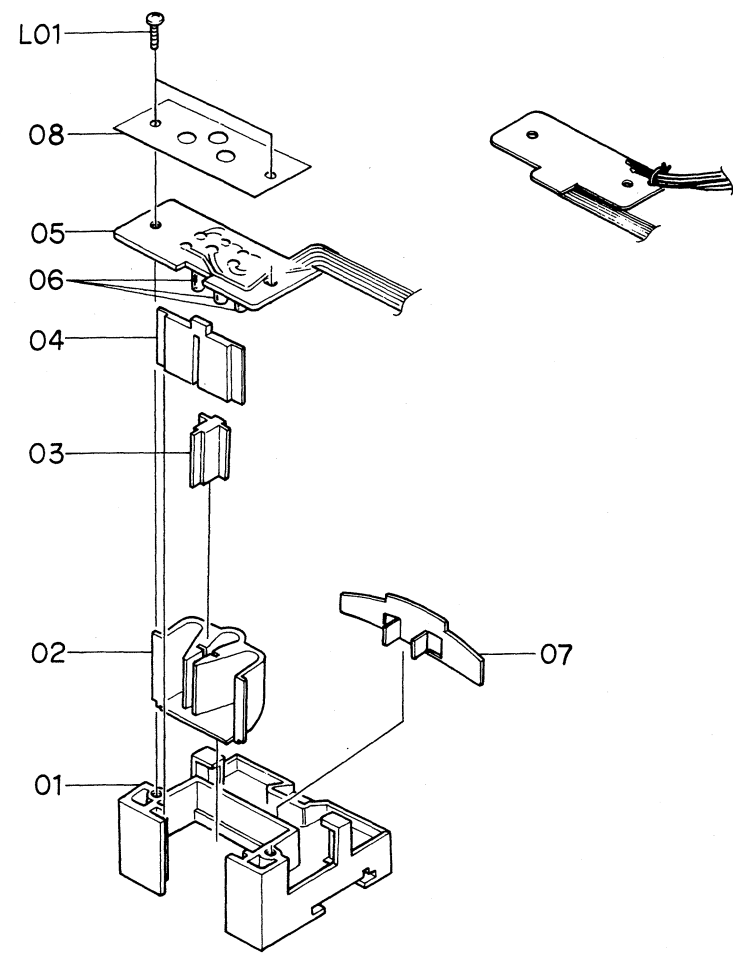

Fig. 7.13

8.2. Amplifier Section

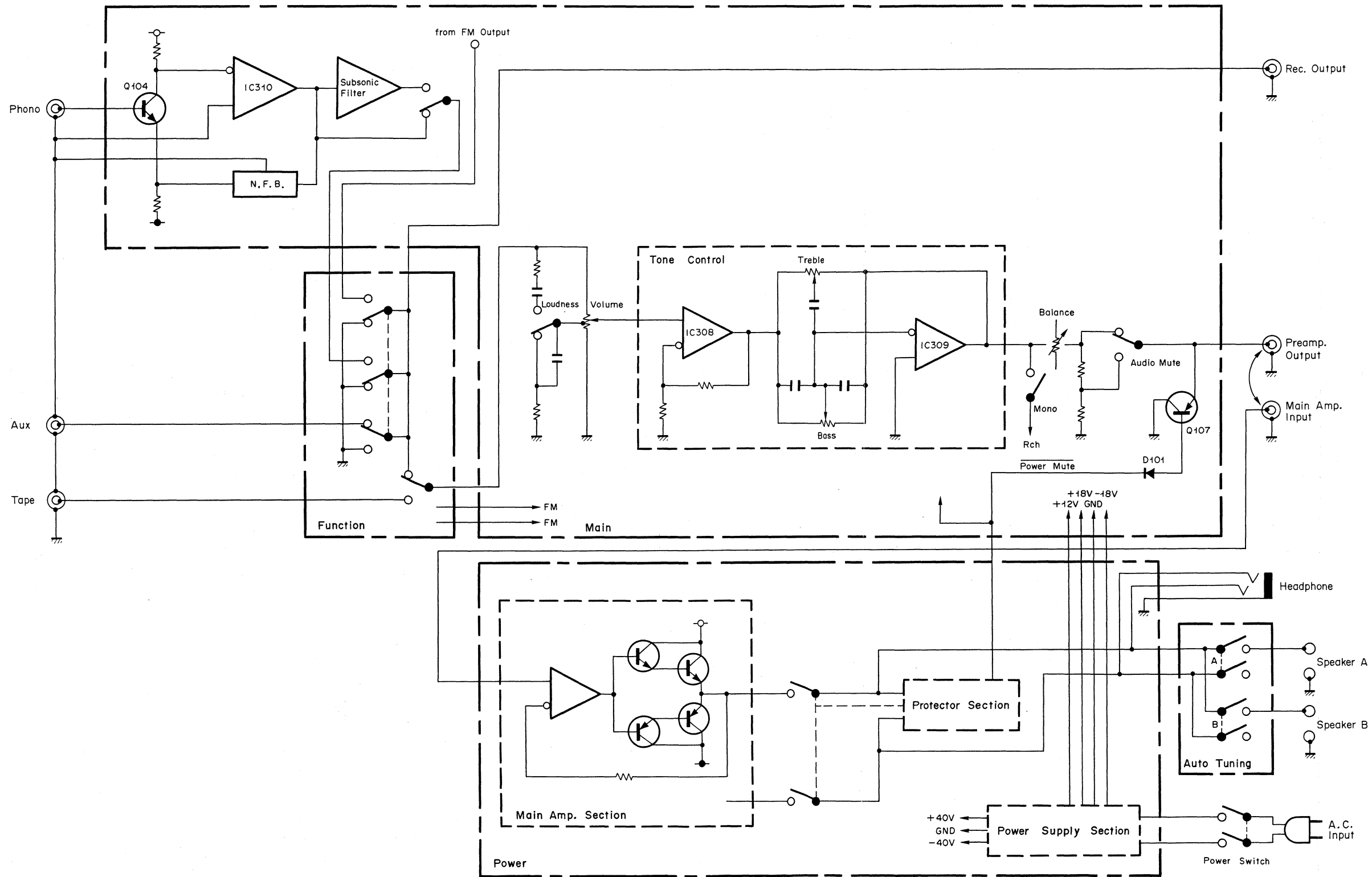

Fig. 8.2

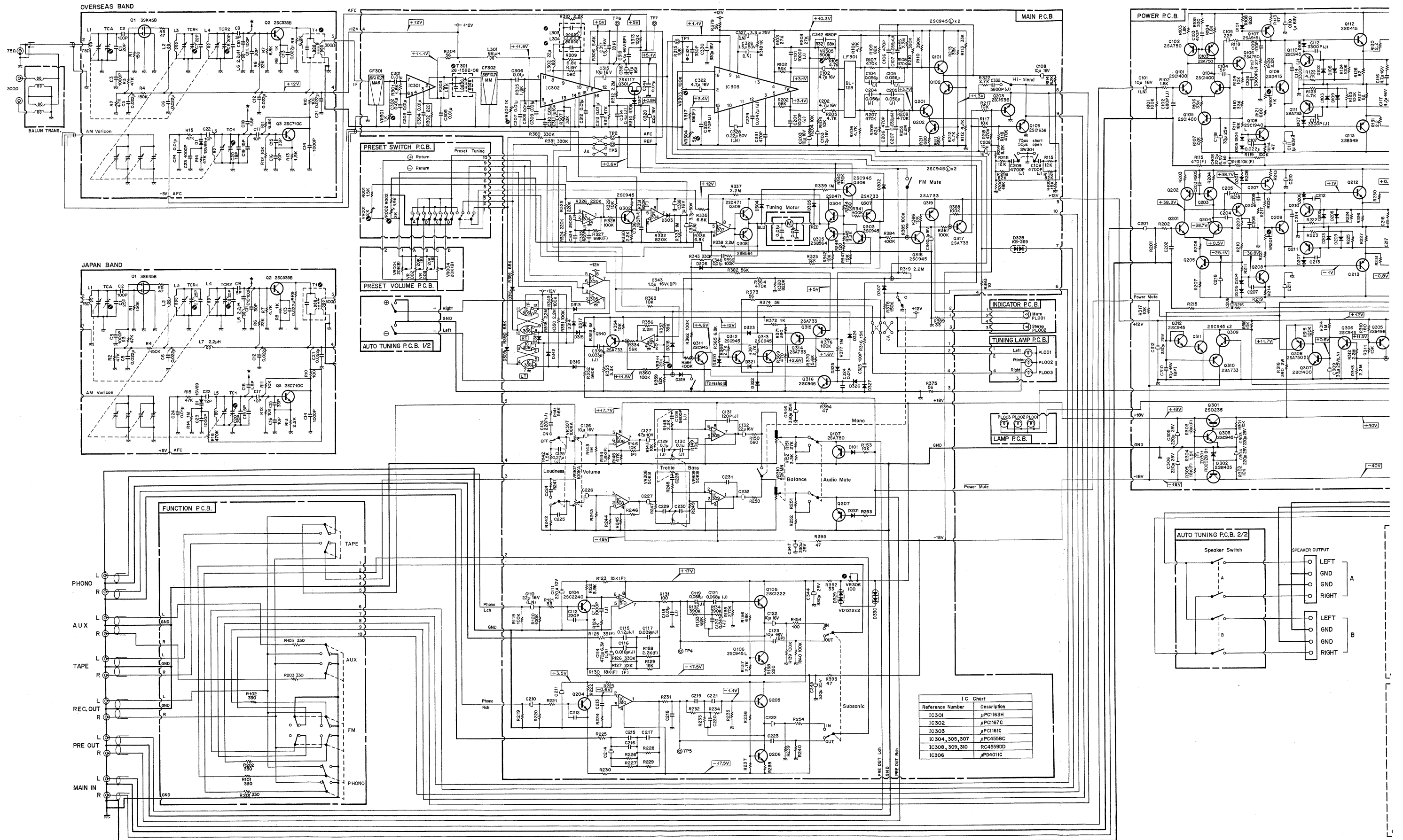

Fig. 10.6

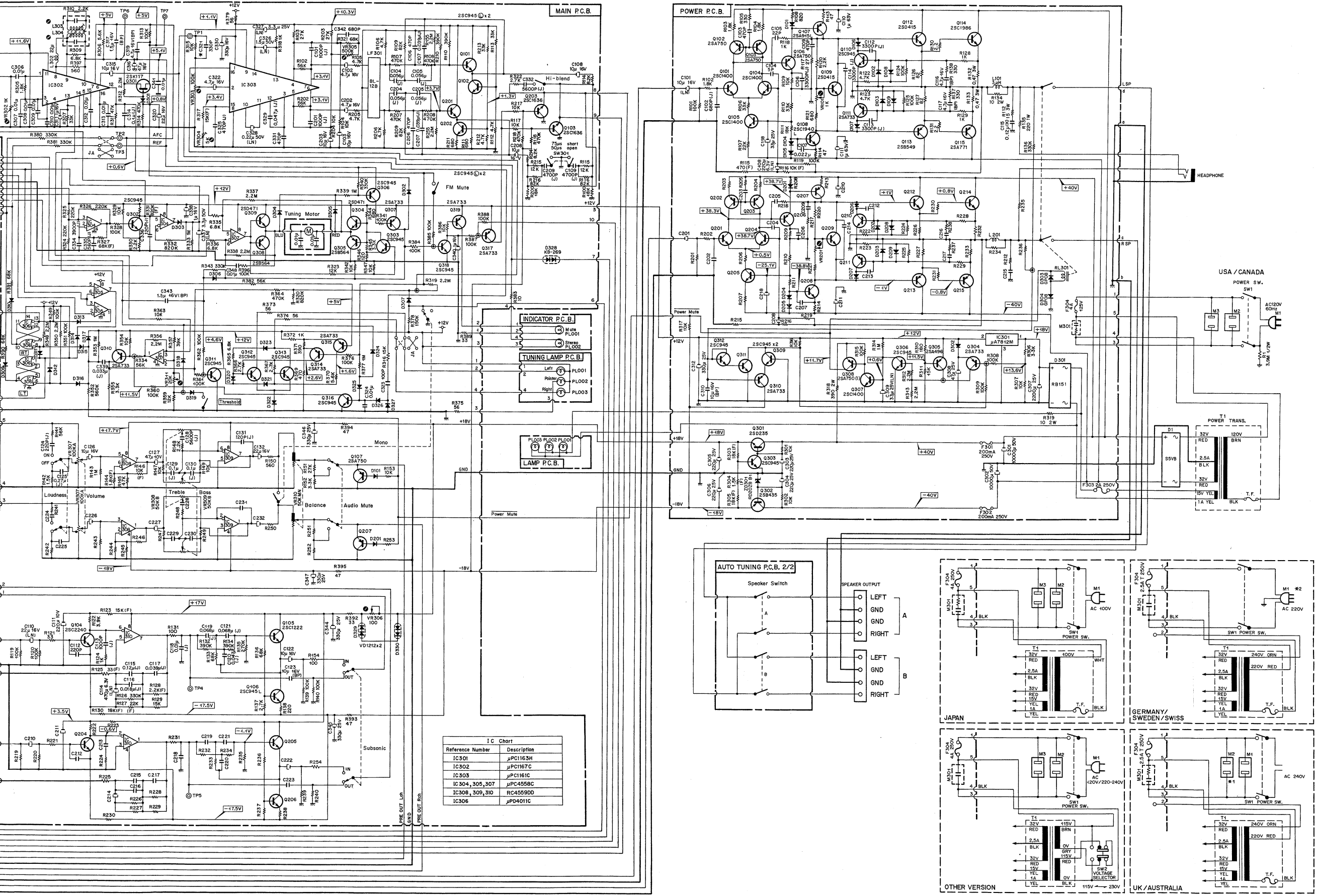

Fig. 10.6



11. WIRING DIAGRAM

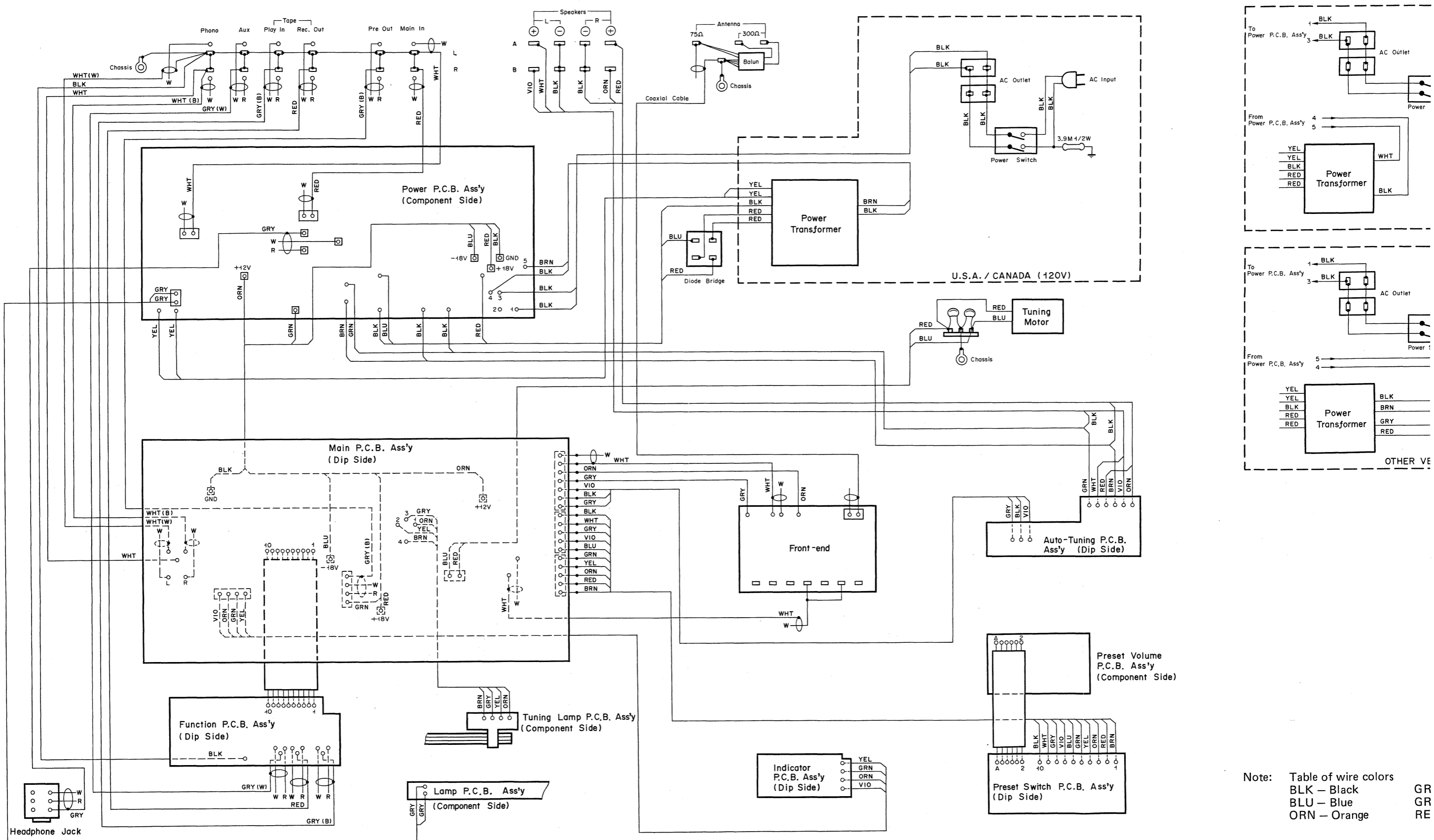

Fig. 11.1

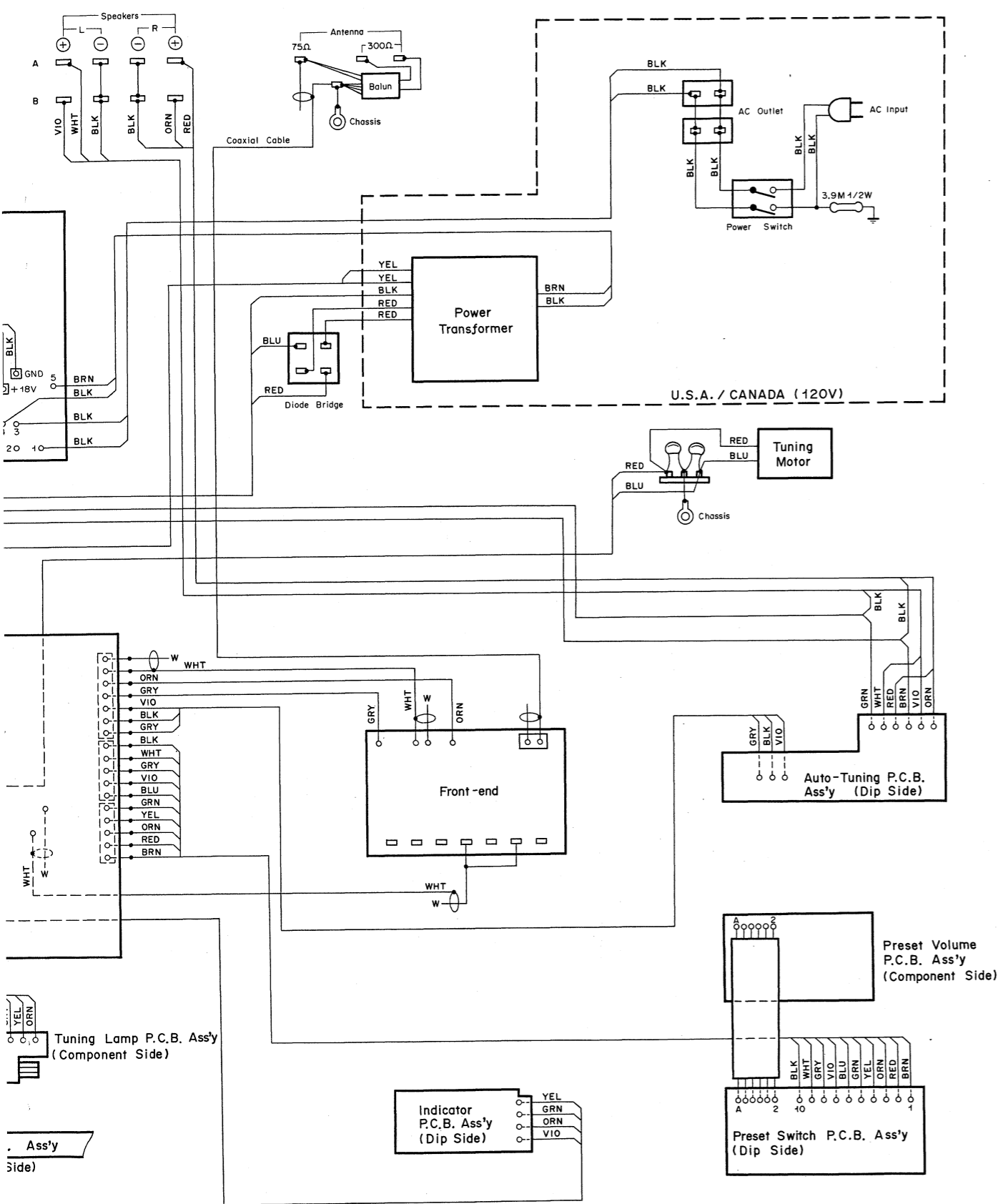

Fig. 11.1

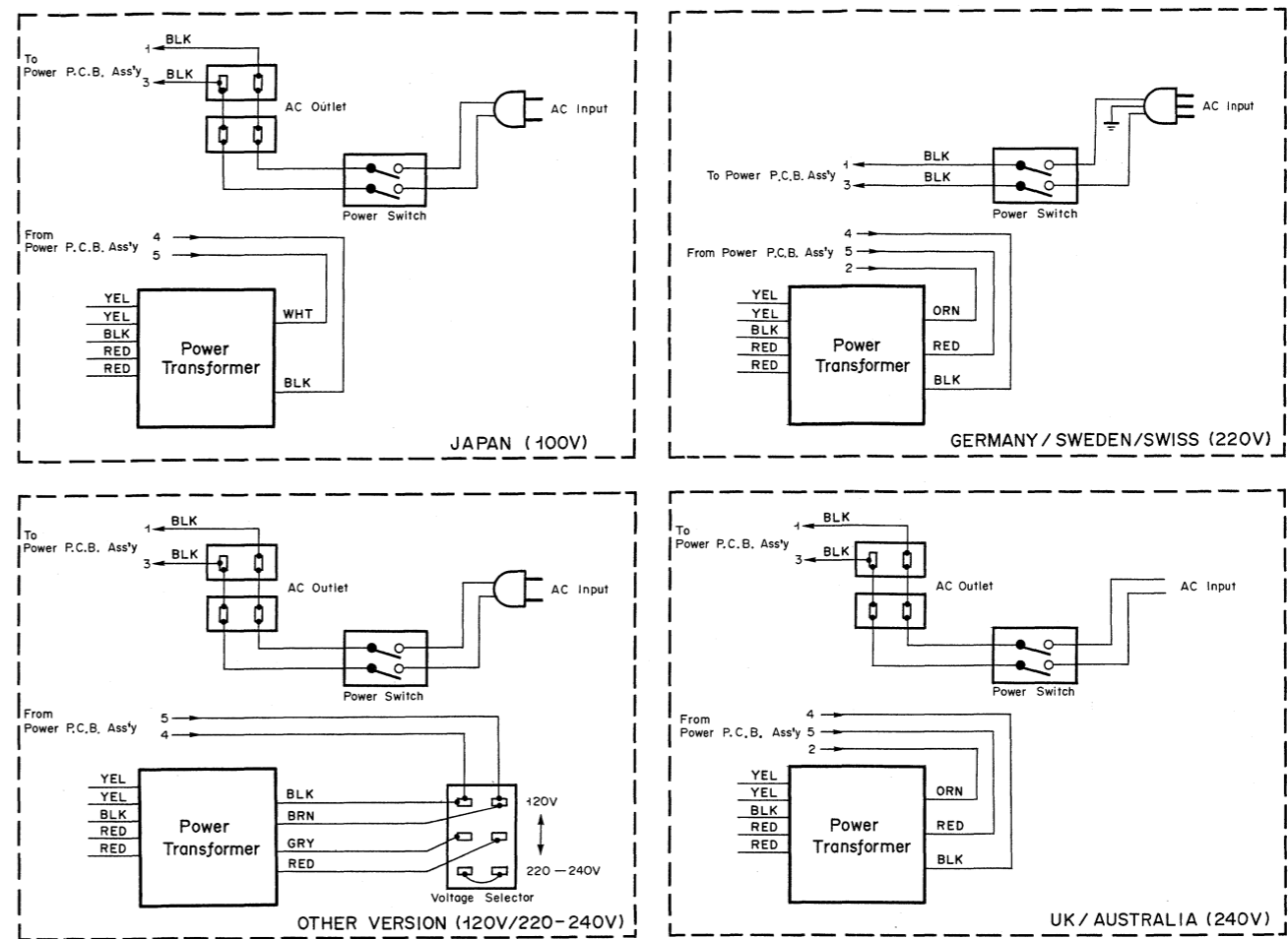

Fig. 11.2

Note: Table of wire colors  
 BLK - Black      GRY - Gray      BRN - Brown  
 BLU - Blue      GRN - Green      YEL - Yellow  
 ORN - Orange    RED - Red      WHT - White

## 12. SPECIFICATIONS

### Power Amplifier Section

Power Output .....	55 Watts per channel, minimum continuous sine wave at 8 ohms, 10 – 20,000 Hz, with less than 0.02% THD
IHF Power Bandwidth ..	80 Watts per channel, minimum continuous sine wave at 4 ohms, 10 – 20,000 Hz, with less than 0.05% THD
	10 – 50,000 Hz for less than 0.1% THD (27.5 W)
	10 – 20,000 Hz for less than 0.01% THD (27.5 W)
Damping Factor .....	Greater than 80, 1 kHz, 8 ohms
Total Harmonic Distortion .....	Less than 0.003% up to 1 kHz Less than 0.006% up to 10 kHz
Inter Modulation Distortion .....	Less than 0.002% at 8 ohms, 55 Watts output (60 Hz: 7 kHz, 4:1)
Frequency Response	
Main in to Sp out, 8 ohms .....	5 – 50,000 Hz +0, -3 dB
Residual Noise .....	Less than 0.03 millivolts
Input Sensitivity/Impedance .....	1 volt/100 kilohms

### Preamplifier Section

Input Sensitivity/Impedance	
Phono .....	2 millivolts/50 kilohms
Aux, Tape .....	150 millivolts/100 kilohms
Frequency Response	
RIAA Deviation .....	Within $\pm 0.3$ dB
Phono Overload .....	130 millivolts
Signal-to-Noise Ratio	
Phono .....	Better than 84 dB, IHF-A, ref. to 2 millivolts (-138 dB equivalent input noise)
Aux, Tape .....	Better than 98 dB, IHF-A
Output Level/Impedance	
Rec Out .....	150 millivolts/330 ohms
Preamp Out .....	1 volt/560 ohms
Loudness Control (VR -40 dB, 1 kHz ref.) .....	+14 dB at 20 Hz +6 dB at 20 kHz
Tone Controls	
Bass .....	$\pm 12$ dB at 20 Hz
Treble .....	$\pm 12$ dB at 20 kHz
Subsonic Filter .....	+0.8 dB at 30 Hz -30 dB at 10 Hz
Channel Separation .....	Better than 70 dB (1 kHz)
Headphone Output .....	60 milliwatts max. into 8 ohms

### Tuner Section

Usable Sensitivity .....	2.2 microvolts at 300 ohms (12.1 dBf)
50 dB Quieting Sensitivity	
Mono .....	5 microvolts at 300 ohms (19.2 dBf)
Stereo .....	55 microvolts at 300 ohms (40 dBf)
Signal-to-Noise Ratio	
Mono .....	Better than 75 dB at 65 dBf
Stereo .....	Better than 68 dB at 65 dBf
Auto Tuning Threshold	20 dBf/40 dBf
Frequency Response ....	30 – 15,000 Hz +1, -1.2 dB
Distortion	
Mono .....	Less than 0.15% at 1 kHz, 100% modulation, 65 dBf
Stereo .....	Less than 0.2% at 1 kHz, 100% modulation, 65 dBf
Capture Ratio .....	1.5 dB
Channel Selectivity ( $\pm 400$ kHz) .....	Better than 75 dB
Stereo Separation .....	Better than 45 dB at 1 kHz Better than 30 dB at 10 kHz
Spurious Response	
Rejection .....	Better than 90 dB at 98 MHz
Image Rejection .....	Better than 85 dB at 98 MHz
IF Rejection .....	Better than 90 dB at 98 MHz
AM Suppression .....	Better than 55 dB
SCA Rejection .....	Better than 70 dB
Antenna Input .....	300 ohms balanced or 75 ohms unbalanced
Frequency Band .....	88 MHz – 108 MHz
<b>General</b>	
Power Requirements ....	100, 120, 120/220-240, 220 or 240 Volts AC, 50/60 Hz
Power Consumption ....	350 Watts
AC Outlets .....	2 switched, 150 Watts maximum
Dimensions .....	500(W) x 130(H) x 350(D) millimeters 19-11/16(W) x 5-1/8(H) x 13-25/32(D) inches
Weight .....	12.35 kg, 27 lb. 5 oz