



Service Manual

Nakamichi 580M 2 Head Cassette Deck



1. General	3
2. Principle of Operation	5
2. 1. Mechanisms	5
2.1.1. Headblock	5
2.1.2. Erase Head	6
2.1.3. Double Capstan Tape Drive	6
2.1.4. Mechanism Control Cam Operation	7
2. 2. Amp. Circuits	8
2.2.1. Playback Eq. Amp. Circuit	8
2.2.2. Record Amp. Circuit	10
2.2.3. Bias Osc. Circuit	10
2. 3. Mechanism Control Circuits	11
2.3.1. Logic Control	11
(1) C-MOS IC	11
(2) Logic Control and Other Circuits	13
2.3.2. Shut-off Sensor and Detector	18
2.3.3. Control Motor Drive Circuit	19
2.3.4. Capstan Motor Governor	20
2.3.5. Reel Motor Governor	21
2. 4. Remote Control Unit RM-580 (Optional)	22
2.4.1. Introduction	22
2.4.2. Transmitter	22
2.4.3. Receiver	23
3. Removal Procedures	25
3. 1. Acrylic Cassette Compartment Cover	25
3. 2. Top Cover Ass'y	25
3. 3. Bottom Cover Ass'y	25
3. 4. Front Panel Ass'y	25
3. 5. Mechanism Ass'y	25
3. 6. Main P.C.B. Ass'y	26
3. 7. Logic P.C.B. Ass'y	26
3. 8. Power Switch	26
3. 9. Volume P.C.B. Ass'y	26
3. 10. Control Switch P.C.B. Ass'y	26
3. 11. Record Cal. P.C.B. Ass'y	26
3. 12. Meter Ass'y	27
3. 13. Lamp P.C.B. Ass'y	27
3. 14. Aluminum Mirror	27
3. 15. Rear Panel Ass'y	27
3. 16. Power Transformer	27
3. 17. Cassette Case Ass'y	27
3. 18. Cover Plate Ass'y	28
3. 19. Tape Counter Ass'y	28
3. 20. Capstan Motor Ass'y and Flywheel Ass'y	29
3. 21. Sub Mechanism Chassis Ass'y	29
3. 22. Control Motor Ass'y	29
3. 23. Reel Motor Ass'y	29
3. 24. Cam Control Volume	29
3. 25. Reel Hub Ass'y	29
3. 26. Idler Ass'y	29
3. 27. Cam Drive Gear and Control Cam	29
3. 28. Head Mount Base Ass'y	29
3. 29. Supply Pressure Roller Ass'y	30
3. 30. Erase Head	30
3. 31. Take-up Pressure Roller Ass'y	30
3. 32. Record/Playback Head Ass'y	30

4. Measurement Instruments	31
5. Mechanical Adjustments	32
5. 1. Mechanism Control Cam Adjustment	32
5. 2. Tape Speed Adjustment	33
5. 3. Record/Playback Head Tilt Adjustment	34
5. 4. Head Base Stroke Adjustment in Play and Cue Modes	35
5. 5. Tape Guides Adjustment and Erase Head Stroke Adjustment	36
5. 6. Erase Head Height and Tilt Adjustment	37
5. 7. Record/Playback Head Height Adjustment and Azimuth Alignment	37
5. 8. Tape Travelling Adjustment	38
5. 9. Record Switch Linkage Adjustment	38
5. 10. Flywheel Holder Adjustment	39
5. 11. Eject Wire Adjustment	39
5. 12. Control Button Stroke Adjustment	40
5. 13. Lubrication	40
6. Parts Location for Electrical Adjustment	41
7. Electrical Adjustments and Measurements	42
7. 1. Adjustment and Measurement Instructions	42
7. 2. Frequency Response Adjustment	45
7.2.1. Playback Frequency Response Adjustment	45
7.2.2. Record Current Frequency Response Adjustment	46
7. 3. Dolby NR Circuit Check	46
8. Mounting Diagrams and Parts List	47
8. 1. Main P.C.B. Ass'y	47
8. 2. Logic P.C.B. Ass'y	49
8. 3. Lamp P.C.B. Ass'y	51
8. 4. Control Switch P.C.B. Ass'y	53
8. 5. Volume P.C.B. Ass'y	53
8. 6. DIN-Pin P.C.B. Ass'y	53
8. 7. Shut-off P.C.B. Ass'y	53
8. 8. Record Cal. P.C.B. Ass'y	53
9. Mechanism Ass'y and Parts List	54
9. 1. Synthesis	54
9. 2. Synthesis Mechanism 580M (A01)	55
9. 3. Front Panel Ass'y 580M (B01)	56
9. 4. Headphone Jack Ass'y (B02)	56
9. 5. Mechanism Ass'y 580M (B03)	57
9. 6. Chassis Ass'y 580M (B04)	57
9. 7. Lamp House Cover Ass'y (C01)	59
9. 8. Flywheel Holder Ass'y (D01)	59
9. 9. Sub Mechanism Chassis Ass'y (D02)	60
9. 10. Main Mechanism Chassis Ass'y (D03)	62
9. 11. Rear Panel Ass'y (E01)	63
9. 12. Reel Motor Ass'y (F01)	64
9. 13. Control Motor Ass'y (F02)	64
9. 14. Head Mount Base Ass'y (F03)	64
9. 15. Supply Pressure Roller Ass'y (F04)	65
9. 16. Take-up Pressure Roller Ass'y (F05)	65
9. 17. Head Base Ass'y (F06)	65
9. 18. Cassette Case Holder L Ass'y (F07)	65
9. 19. Cassette Case Holder R Ass'y (F08)	65
9. 20. Auto Shut-off Ass'y (F09)	65
9. 21. Pneumatic Damper Ass'y (F10)	66
9. 22. RP-9E Record/Playback Head Ass'y (G01)	66
10. Eq. Amp. Frequency Response	67
10. 1. Playback Frequency Response	67

10. 2.	Record Current Frequency Response	67
11.	Overall Timing Chart	68
12.	Wiring Diagram	69
13.	Block Diagrams	71
13. 1.	Amplifier	71
13. 2.	Mechanism Control	72
14.	Schematic Diagrams	73
14. 1.	Amplifier	73
14. 2.	Mechanism Control	74
15.	Remote Control Unit RM-580 (Optional)	77
15. 1.	Mounting Diagrams and Parts List	77
15.1.1.	Receiver	77
15.1.2.	Transmitter	78
15. 2.	Schematic Diagrams	78
15.2.1.	Receiver	78
15.2.2.	Transmitter	78
15. 3.	Adjustments	79
15.3.1.	Transmitter	79
15.3.2.	Receiver	79
15.3.3.	Performance Check of Transmitter and Receiver	79
15. 4.	Mechanism Ass'y and Parts List	79
15.4.1.	Receiver	79
15.4.2.	Transmitter	80
16.	Specifications	81

1. GENERAL

1.1. Control Functions

Nakamichi 580M control functions are shown below:

- | | |
|--|---------------------------------------|
| 1. Acrylic Cassette Compartment Cover | 17. Balance Control |
| 2. Cassette Lid | 18. Output Level Control |
| 3. Eject Button | 19. Play Button |
| 4. Counter Reset Button | 20. Stop Button |
| 5. Tape Counter | 21. Rewind Button |
| 6. Record Calibration Controls | 22. Fast-Forward Button |
| 7. Tape Memory Switch | 23. Record Button |
| 8. Timer Record Switch | 24. Pause/Cue Button |
| 9. Tape Selector Switches (EX/SX/ZX) | 25. Head Height and Azimuth Alignment |
| 10. Eq. Switch (70 μ s/ 120 μ s) | 26. Headphone Jack |
| 11. Test Tone Switch | 27. Input Jacks |
| 12. MPX Filter Switch | 28. DIN In/Out Jack |
| 13. Dolby NR Switch | 29. Output Jacks |
| 14. Power Switch | 30. Remote Control Socket |
| 15. Peak Level Meters | 31. Voltage Selector |
| 16. Input Level Control | 32. Power Cord |

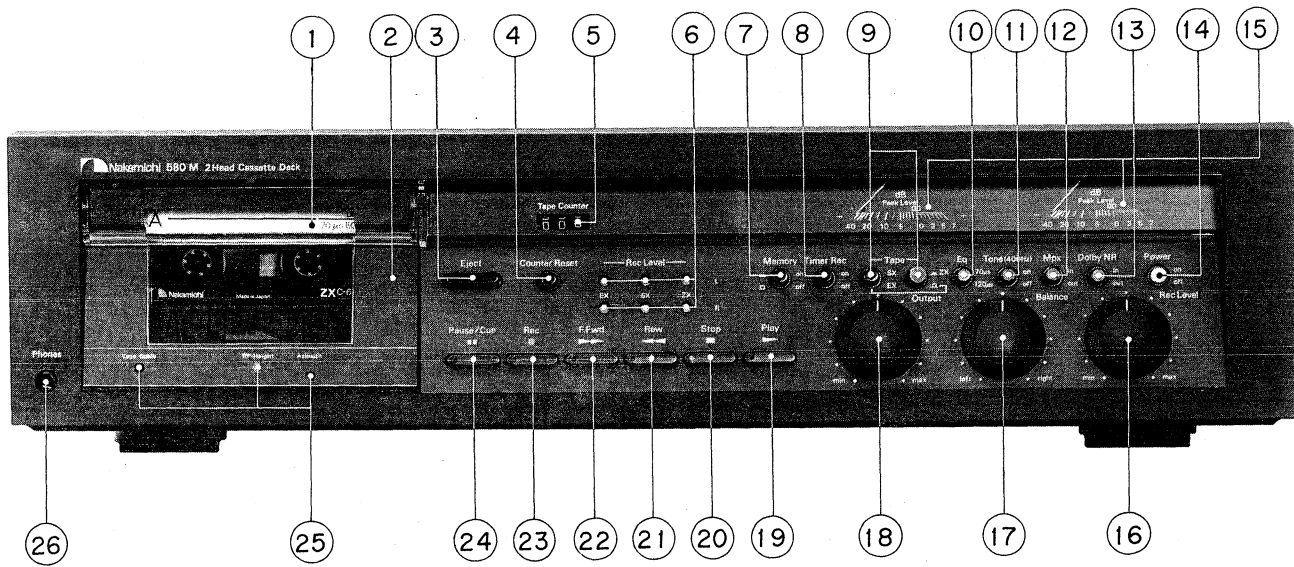

Fig. 1.1 Front View

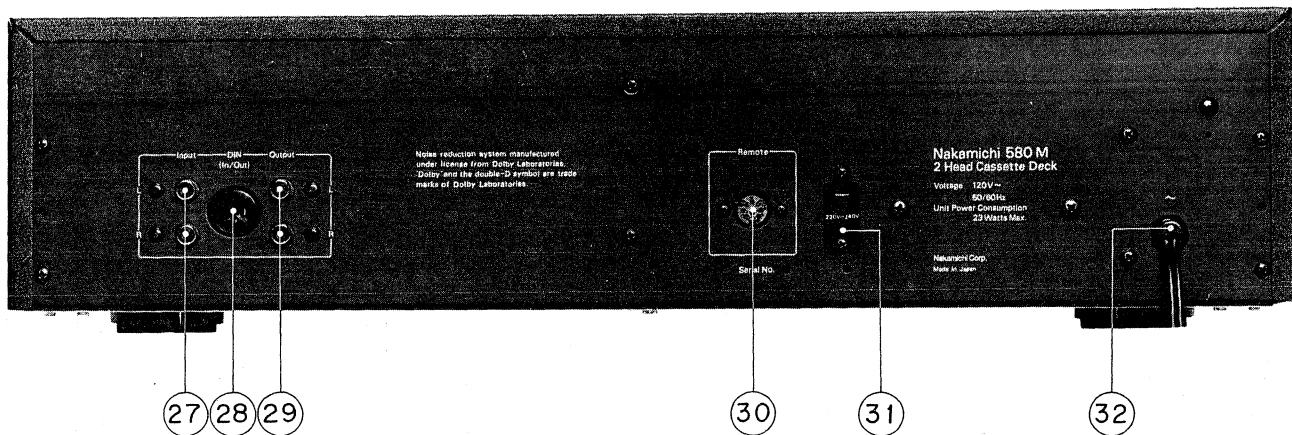

Fig. 1.2 Rear View

1.2. Voltage Selector

Voltage selector is installed on the rear panel for other versions of the Nakamichi 580M. This voltage selector can select either 120 V or 220 – 240 V at customer's disposal.

2. PRINCIPLE OF OPERATION

2.1. Mechanisms

2.1.1. Headblock

Refer to Fig. 2.1.1.

Nakamichi 580M Headblock provides more stabilized tape travel.

Accuracy of tape travel is one of the most essential factors for a device to optimize its performance. Inaccurate tape travel will therefore induce deterioration exemplified by the following:

- (a) vibration will be given to tape travel, as a result of which flutter and modulation noise will become increased
- (b) insufficient tape-to-head contact will result in level drops
- (c) tape skew will become greater and frequency response will become decreased

Needless to say, constant tape travel must consist of smooth drive mechanism, as well as of the fact that tape, heads and tape guide are placed in the most appropriate positions.

N-580M Record/Playback Head is made small in size. Erase Head is located at the place where the Record Head is located in the N-700II/1000II.

Record/Playback Head is assembled on the Head Mount Base. Take-up Tape Guide and Supply Tape Guide are fixed to the Take-up and Supply Pressure Rollers respectively. Erase Head is placed on the Head Base. All these can be separately adjusted. Shape of the Heads and its location have been carefully studied to bring about smoother contact of tape with the Heads. Pad Lifter is affixed to the Record/Playback head so as not to let Tape Pad touch the Head to give more stabilized tape travel, making it free from the influence of the Tape Pad within in the Cassette Tape.

(1) Adjustment of Tape Guide Height

Tape Guides for the N-580M are affixed to the Supply Pressure Roller Ass'y and Take-up Pressure Roller Ass'y. With springs in the studs of Main Mechanism Chassis Ass'y, the Supply Pressure Roller Ass'y and Take-up Pressure Roller Ass'y are tightly affixed with Tape Guide Adjustment Nuts. The Adjustment Nuts are placed on the springs, and therefore either by tightening or loosening, height adjustment of the Tape Guides will become possible.

(2) Record/Playback Head Height Adjustment and Azimuth Alignment

Azimuth and height of Record/Playback Head are independent from each other and adjustment may be done separately without affecting others. In order to adjust the tilt of Record/Playback Head backwards or frontwards, take off the Height Gear Stopper and take out the Height Gear and then turn the two Height Adjustment Screws. After completion of adjustment, place the Height Gear back and fix it with the Height Gear Stopper. After the tilt is adjusted in such a way as above, adjust the height by turning the Height Gear. Azimuth is aligned by turning the Azimuth Alignment Screw. This system has been carefully designed so as to minimize influence each other between azimuth alignment and height adjustment.

(3) Erase Head Height and Tilt Adjustment

Erase Head is affixed onto the Erase Head Plate which is assembled with the Head Base. It is installed with three screws. By turning these screws, its height, tilt of backward or forward, and tilt of leftward or rightward can be adjusted separately, thus the best location of Erase Head can be obtained.

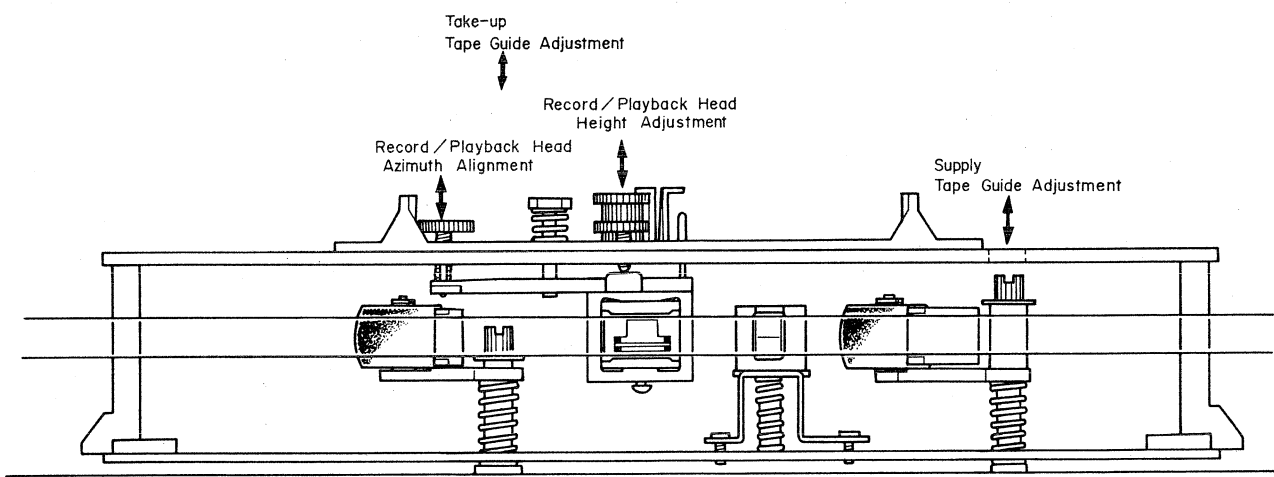

Fig. 2.1.1 Headblock

2.1.2. Erase Head

Fig. 2.1.2 shows the sectional view of the Erase Head. Fig. 2.1.3 shows the characteristics of erasing current and erasure.

It has the same characteristics with the previous type Direct-Flux Erase Head but been purposely developed to minimize the size further.

Conventional Erase Head had its inside core narrower than its outside core, while this Erase Head is equipped with an inside core wider than the outside core. This has resulted more power sufficient enough for erasing with small power consumption, approx. 0.5 W, though the head width is as small as 3 mm. The smaller the power consumption is, the smaller will be the heat generation, and this is of course another merit.

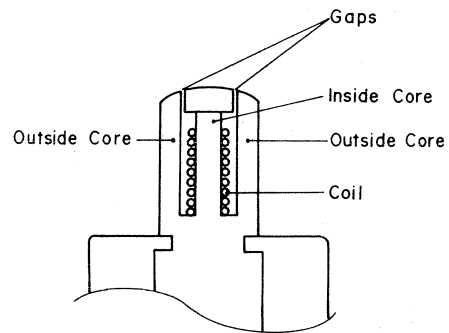

Fig. 2.1.2 Sectional View of Erase Head

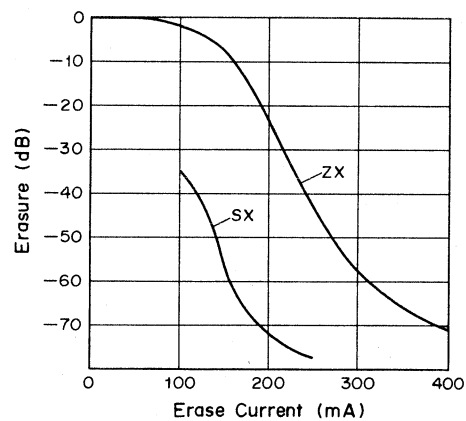

Fig. 2.1.3 Characteristics of Erasing Current and Erasure

2.1.3. Double Capstan Tape Drive

As shown in Fig. 3.1.4, the double capstan system consists of two capstan shafts (a) and (b) connected to the two flywheels which are driven by a capstan belt.

Against these capstans two pressure rollers (a) and (b) are engaged to run the tape with an adequate holdback tension created by the double capstan and pressure rollers.

Since the diameter of capstan shaft (a) is smaller than that of capstan shaft (b), when two flywheels begin to turn as shown in the figure, capstan (a) runs slightly faster than capstan (b), which subsequently generates holdback tension.

As you note, if the diameters of the 2 capstans should be the same, the generation cycles of wow and flutter will become approximately the same, as a result of which defective portion will be doubly superposed and preferable portion vice versa. The N-580M employs 2 capstans, each having different diameter and rotations, thereby avoiding the aforesaid occurrence and stabilizing wow and flutter characteristics.

As the double capstan system always creates a constant and stable holdback tension between the two capstans, the condition of the tape between two capstans will not be affected by any external conditions such as irregular take-up and supply torques, irregular loading of cassette tape, undesirable mechanism vibration and etc., thus assuring the superior wow and flutter characteristics. The double capstan system provides a constant holdback tension on the tape and maintains the stable pressure onto the tape against the heads.

The only critical factor in the double capstan system is to be considered; the two capstans have to be positioned perfectly in parallel and to be precisely vertical against the head base, the pressure rollers have to be evenly pressed against the capstan shafts and the head surface must be positioned perfectly vertical to the tape surface. Otherwise, the running tape might become out of the tape guide resulting in irregular movement.

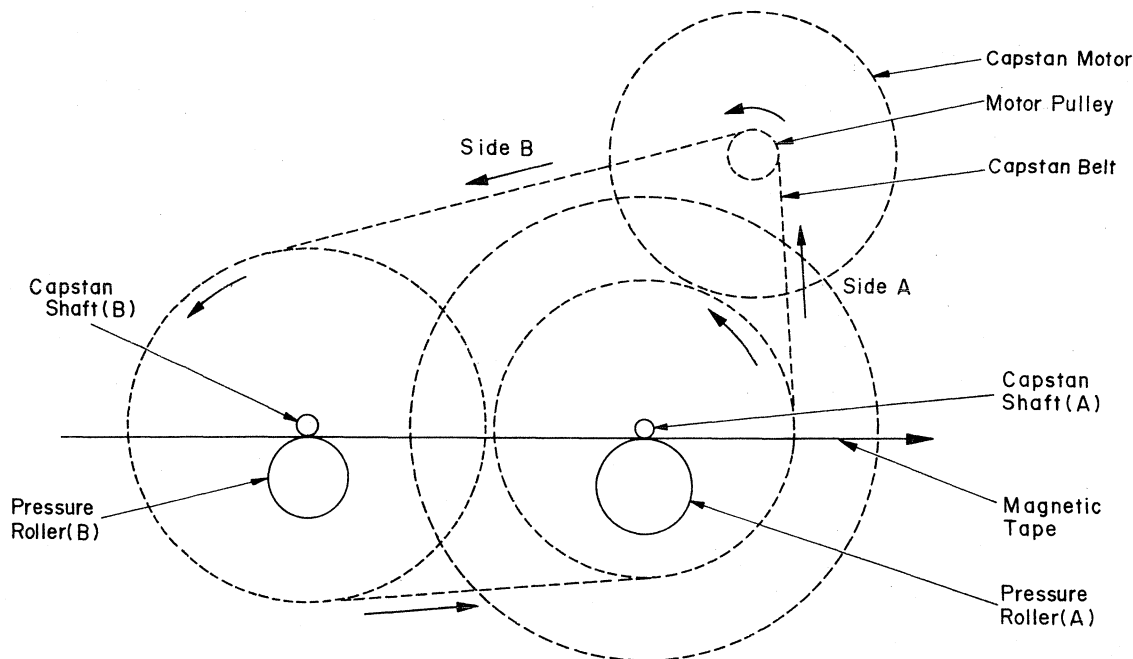

Fig. 2.1.4 Double Capstan Tape Drive

2.1.4. Mechanism Control Cam Operation

Refer to Fig. 2.1.5 Mechanism Control Cam timing chart. Function of N-580M Mechanism is done by Cam Control. Cam is driven by the Control Motor. The Motor operates so as to result zero in the difference of voltages between each voltage corresponding to mechanism function and each reference voltage which corresponds to each commands of the Control Switch. When the difference comes to zero, then it stops. In this way, each function is kept properly operated. For further details, please see the explanation on Logic Control. Here we explain principle of its mechanical functions.

Cam Control System works as follows: Cam Drive Gear is driven by Control Motor by means of Drive Belt. Cam Drive Gear is related to the cam with which each function may be mechanically set on.

(1) Play Mode

Press the Play Switch to make it Play mode. Then the Cam begins to move from Stop position to Play position and the Play mode will be set.

The Head Base which is linked to the Cam and which is normally pushed against the Stop position gets released and the Head Base will slowly come out for playing. To explain this function, first the Head Base is latched and the Reel Motor begins to turn. Then the Pressure Roller will be pushed and the Brake will be released. Now the tape begins to run. If you press the Pause Switch at this stage, it comes to Pause mode. Brake operates and the Pressure Roller moves away from the Capstan and the

Reel Motor stops.

Play mode may be changed to Stop mode by pressing the Stop Switch, and latch of the Head Base being released. The Cassette Case cannot be opened because of the latched eject effect unless it is in Stop mode.

(2) Record Mode

By pressing the Record Switch and the Pause or Play Switch, it may be made to Record mode. The Cam at this moment moves from Stop position to Rec. position. At the same time, Rec. Trigger Mechanism is driven and the Record Switch on the Main P.C.B. is switched on to the Record side. Further, the Cam turns until it comes to the Pause or Play position. On the other hand, the Rec. Trigger Mechanism is released during this process. When the Cam is set in Rec./Pause or Rec./Play position, Record signals will be sent to Bias Oscillating Circuit from Logic Control Circuit to let the Bias to oscillate.

Press the Stop Switch and the Cam comes back to the Stop position. At the same time, it will set the Record Switch on the Main P.C.B. to the Play side.

(3) F.F. or Rewind Mode

By pressing F.F. or Rewind Switch, it comes either to F.F. or Rewind mode. The only difference of these two modes is that one is to turn the Reel Motor reverse and the other to transmit the torque against the Reel Hub onto the take-up side or to the supply side. Brake is released at this stage and the Reel Motor begins to turn F.F. or Rewind.

(4) Pause Mode

Press the Pause Switch to make it to Pause mode. In changing it from Stop mode to Pause mode, the Brake is first released, then the Head Base is latched, and again the Brake works.

At this stage, the Reel Motor would not turn with the Pressure Roller being apart from the Capstan, and the tape would remain still.

(5) Cue Mode

Cue mode may be either of Forward Cue or of Reverse

Cue mode.

In either case, it could be effected by pressing F.F. Switch or Rewind Switch after the Pause Switch has been pressed. The speed of the tape at this moment will be 1/3 the running speed of normal F.F. or normal Rewind. The tape speed will get slow further down to 1/5 the speed of F.F. or of Rewind if you keep on pressing the F.F. or Rewind Switch. In this case, the Brake is released at first and then the Head Base will get latched at the Cue position and the Reel Motor will start while the Pressure Roller remains apart from the Capstan.

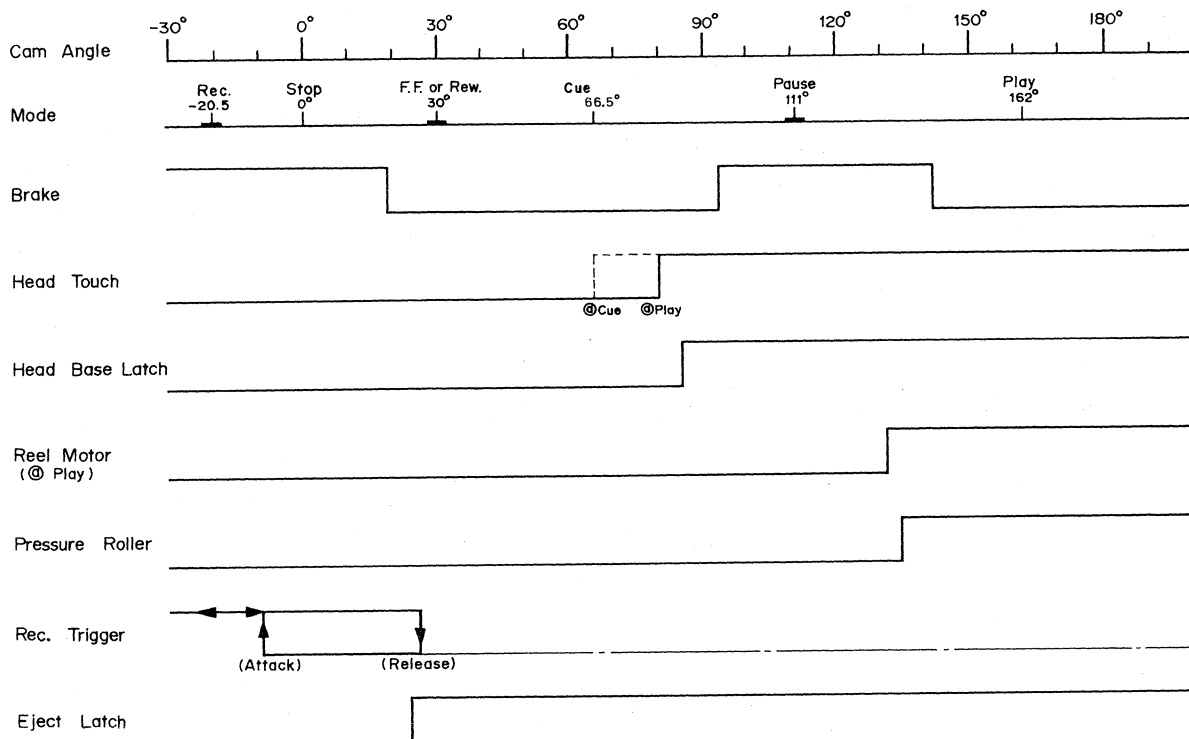

Fig. 2.1.5 Mechanism Control Cam Timing Chart

2.2. Amp. Circuits

2.2.1. Playback Eq. Amp. Circuit

Fig. 2.2.1 shows the playback equalizer circuit, and Fig. 2.2.2 shows the system diagram.

Fig. 2.2.3 shows the time constant of equalizer. The playback head is connected with circuit's input.

Amplifier (Q103, 104 and 105) is an equalizer amplifier and its time constant is illustrated in Fig. 2.2.3. R145, R146, L105, and C139 compose of a peaking circuit. This circuit compensates the gap loss of the playback head so that high-frequency response will be improved.

Playback Eq. Amp. gain is adjusted by semi-fixed volume VR102 (VR202) to obtain 100 mV output level at TP101 (TP201) when 400 Hz Level Tape (DA09005A) is being played back. Equalizer switch (70 μs/120 μs) is connected with Amp. The overall time constants in Playback Eq. Amp. are as follows:

Eq. SW - 70 μs

3180 μs (50 Hz) + 70 μs (2274 Hz)

Eq. SW - 120 μs

3180 μs (50 Hz) + 120 μs (1326 Hz)

Shown below is the table for the position of Tape Switch and Eq. Switch:

Tape SW	Eq. SW	Tape
ZX	70 μs	Nakamichi ZX
SX	70 μs	Nakamichi SX, TDK SA, Maxell XL-II, Scotch Master 70 μs
EX	120 μs	Low-Noise High-Density (including EX, EXII, TDK AD, Maxell XL-I, Scotch Master 120 μs)
	70 μs	Nakamichi EX, EXII

It is specified in IEC Standard that time constant is 120 μ s on tapes of ferric oxide, and 70 μ s on tapes of CrO₂. However, in the case of Eq. Switch on the N-580M, when time constant at playback is changed, at the same time time constant at record must also be changed. Therefore, even though record and playback is made by the method other than the IEC Standard, no deterioration

of frequency response or level difference will occur. (Any other method for instance, record and playback on ferric oxide tape with putting Tape Switch on EX and Eq. Switch on at 70 μ s.)

When Nakamichi EX or EXII Tape is used at Tape Switch: EX, and Eq. Switch: 70 μ s, S/N ratio will be improved by approximately 4 dB (WTD).

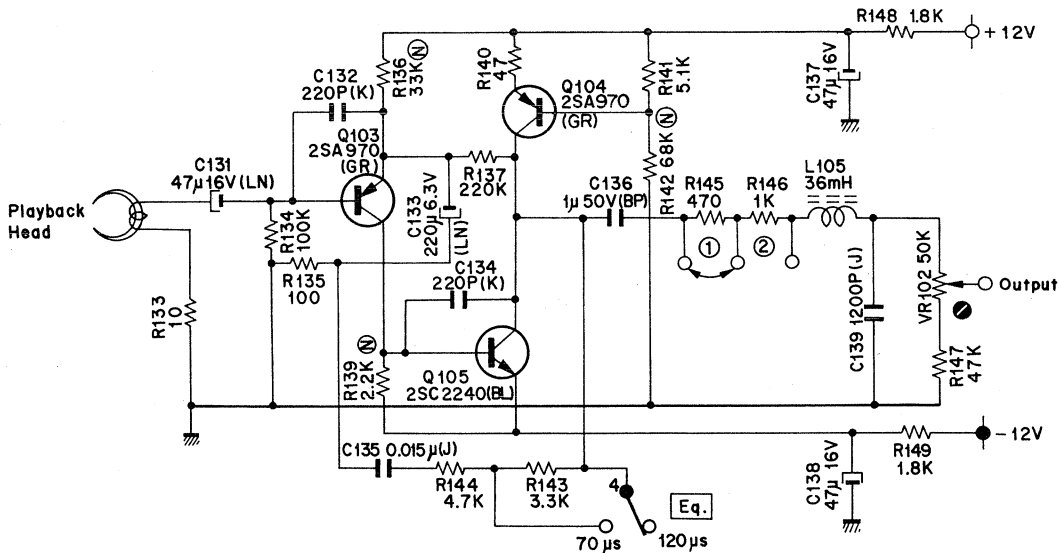

Fig. 2.2.1 Playback Eq. Circuit

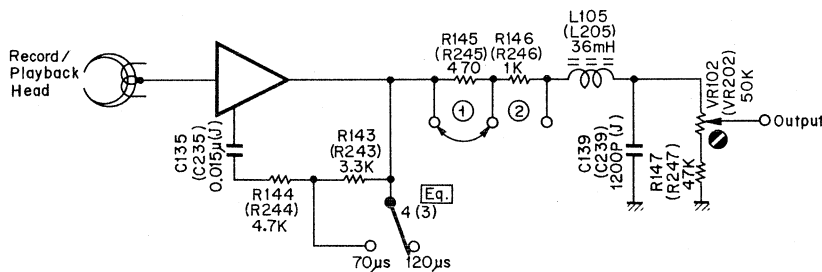

Fig. 2.2.2 System Diagram

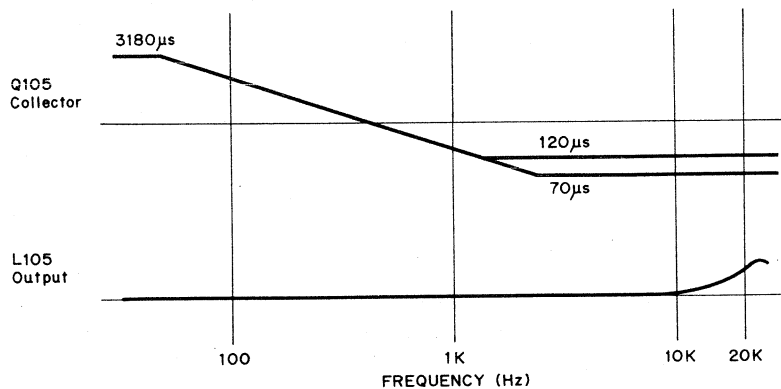

Fig. 2.2.3 Time Constant

2.2.2. Record Amplifier Circuit

Fig. 2.2.4 shows a record amplifier circuit employing a low noise Operational Amplifier IC. This circuit adopts the direct coupling system, i.e., DC Amp. output is con-

nected directly with the record head.

Direct coupling system provides an improvement of linearity, less distortion (as a clipping level becomes higher), etc.

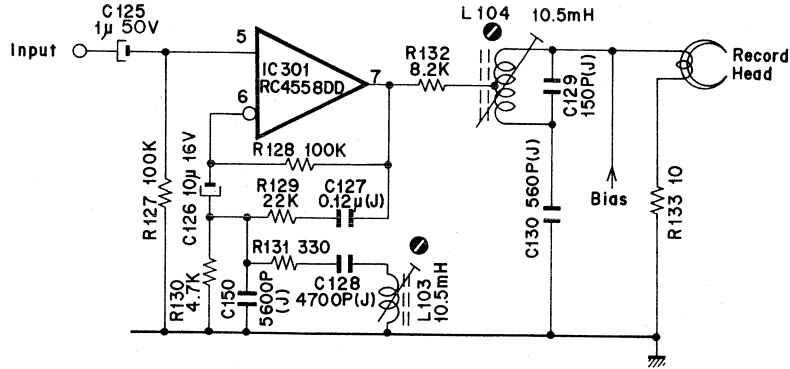

Fig. 2.2.4 Record Amp. Circuit

2.2.3. Bias Osc. Circuit

Fig. 2.2.5 shows a push-pull oscillator with an oscillation frequency of 105 kHz which is constructed by capacitors C312 and C313 coupling the collectors and bases of two transistors (Q301 and Q302).

This is used to provide recording bias and as an erase signal.

By pressing the Record and Pause, or Record and Play

switches, Rec. signal conducted from the Logic P.C.B. becomes L and Q303 turns to ON.

Therefore, +12 V is applied to the circuit through Q303, as a result of which oscillation begins.

When the record mode is released, oscillator output is damped by the discharge of C311. This prevents magnetization of the head.

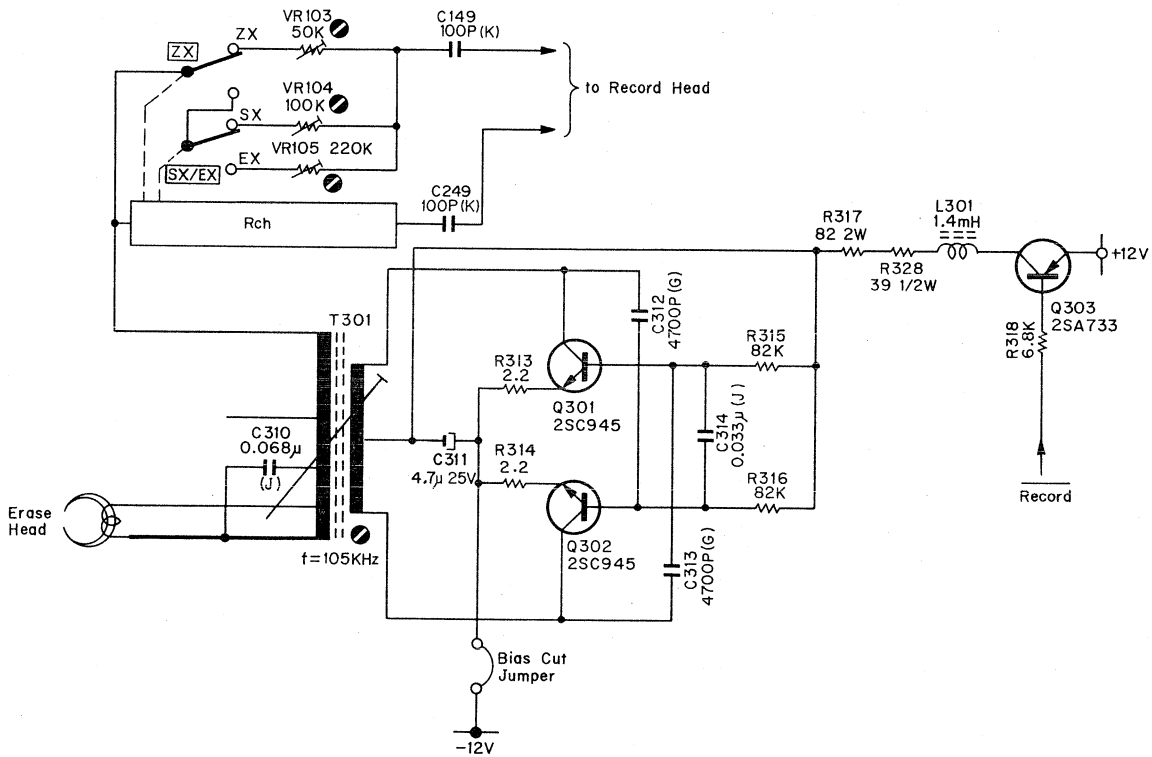

Fig. 2.2.5 Bias Osc. Circuit

2.3. Mechanism Control Circuits

2.3.1. Logic Control

Refer to Fig. 13. 2 block diagram for mechanism control circuits.

(1) C-MOS IC

(a) Features of C-MOS IC

The IC's used in the logic circuit of the N-580M are of the C-MOS (complementary metal oxide semiconductor) type, in which P-channel and N-channel MOS FET's complement each other.

1) Small power consumption

A C-MOS is an inverter, as shown in Fig. 2.3.1.

Whether the input of this inverter is at "H" or "L" level, either the P-channel or N-channel MOS FET is OFF, and therefore, current does not pass from VDD to VSS under steady normal state. Consequently, when there is no input, power consumption ($V_{DD} \times I_{DD}$) is nearly zero, except for surface and junction leakage.

When the input signal is switched from "H" to "L", or "L" to "H", however, both P- and N-channel FET's instantly come on, and a current flows either charging or discharging the stray output capacity, so that the power consumption during dynamic operation cannot be said to be zero.

2) A large noise margin

The input-output transmission characteristics of the C-MOS inverter differ from those of bipolar IC's as shown in Fig. 2.3.2. The knee characteristic is sharper, the threshold voltage is almost half of VDD, and the output amplitude is nearly equal to $V_{DD} - V_{SS}$.

Since the noise margin of a digital IC is defined as the difference between the minimum value of output amplitude and the minimum required amplitude of the input signal, it is quite natural that the C-MOS circuit, which produces an output amplitude of nearly $V_{DD} - V_{SS}$ and is operated by a small input signal, should have a large noise margin.

3) High input impedance

A C-MOS IC has a very high input impedance because it is insulated from the substrate by the oxide film of the gate. Although leakage resistance must be considered in an actual C-MOS IC because diodes are usually used in the direction of reverse bias for protecting input circuit, its impedance is several tens of megohms. The advantage of a high input impedance is that the fan-out of the IC is large, which simplifies the interface. Also, a timer circuit for a longer period of time can be produced. This means that the high input impedance enables the input to be connected with a large resistance, but does not mean to use a capacitor of large capacity.

4) Wide operating voltage range

Fig. 2.3.3 shows input-output transfer characteristics of C-MOS. The general purpose C-MOS family has a wide operating voltage range extending from 3 to 18 V, which is much wider than that of TTL and DTL (5 ± 0.25 V), and HTL (15 ± 1.5 V). The reason for the C-MOS IC's wide operating voltage range is that the P-MOS and N-MOS are made symmetrical, and if VDD is varied, the threshold voltage for the circuit is always about half of VDD. In a bipolar IC, the threshold voltage is decided by the forward voltage from the base to the emitter of the transistor (V_{BE}), and is little affected by the source voltage. Therefore, if the source voltage exceeds a certain limit, the output voltage and the threshold voltage will not balance, as a result of which operation will become impossible.

With a C-MOS, the threshold voltage varies according to changes in the source voltage, and stable operation throughout a wide range can be expected. As indicated above, the performance of a C-MOS IC as a digital IC is excellent.

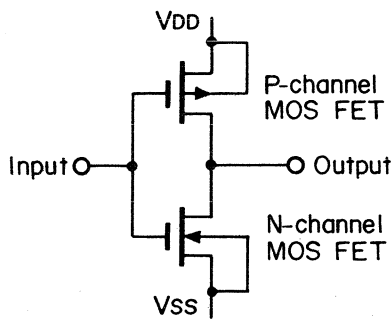

Fig. 2.3.1

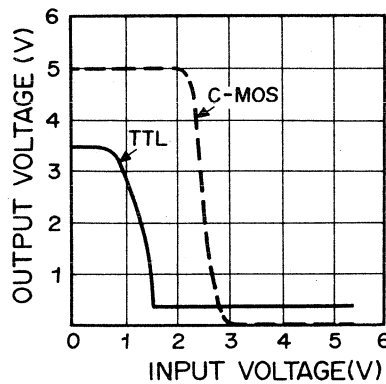

Fig. 2.3.2

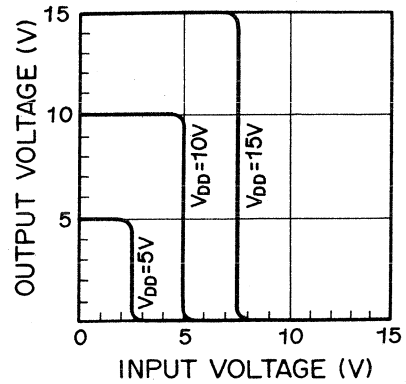

Fig. 2.3.3 Input-Output Transfer Characteristics of C-MOS

(b) Gate Logic

2-input NOR and NAND gates are used.

Following shows each logic symbol, truth table, pin assignment, and internal schematic diagram.

1) NOR Gate

The output will be H only if inputs IN1 and IN2 are L's, and the output will be L if IN1 is H or IN2 is H.

(H: +12 V, L: 0 V)

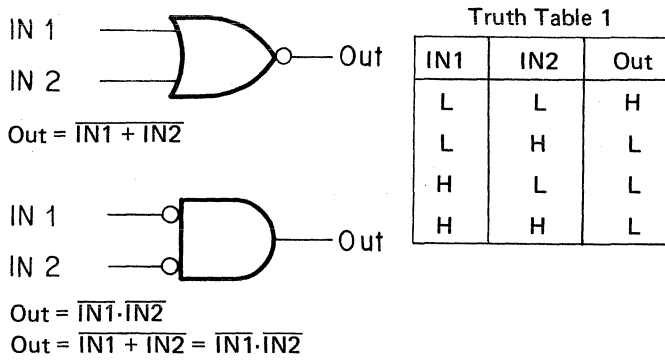

Fig. 2.3.4

The construction of the foregoing 2 Logic Symbols is identical and intended to show the use of either OR or AND.

2) NAND Gate

The output will be L only if inputs IN1 and IN2 are H's, and the output will be H if IN1 is L or IN2 is L.

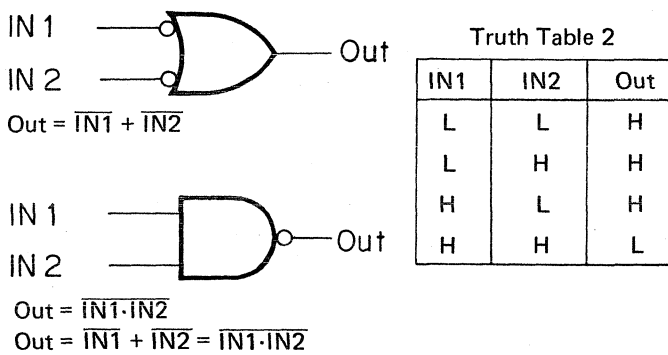

Fig. 2.3.7

The construction of the foregoing 2 Logic Symbols is identical and intended to show the use of either AND or OR.

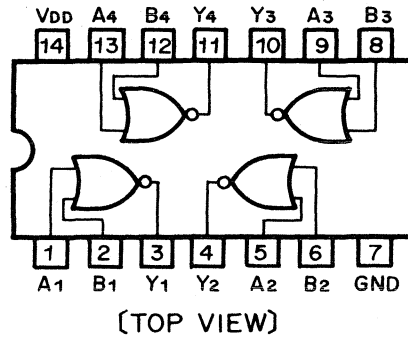

Fig. 2.3.5

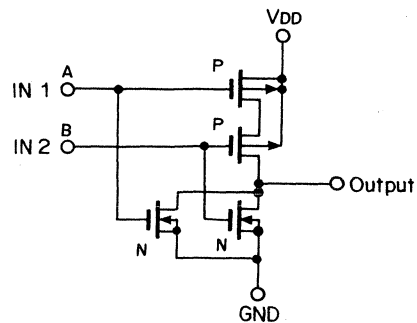

Fig. 2.3.6

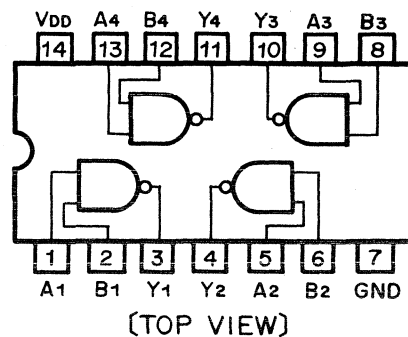

Fig. 2.3.8

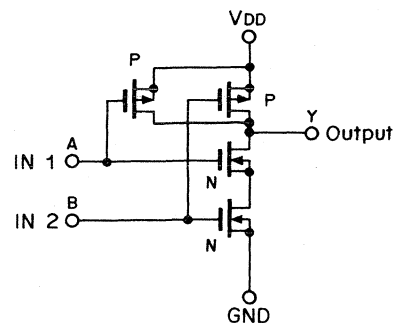

Fig. 2.3.9

(c) Gated Flip-Flop

The two NAND gates can be used to form flip-flop. The inputs operate as follows:

When both S and R are H's, the flip-flop will remain in its present state, i.e., will not change the state.

If however, the R input goes to L, the NAND gate connected to R will have H output regardless of the other feedback input to the NAND gate, and this will force the flip-flop to the L state (provided the S input is kept H). Similar reasoning shows that making the S input an L will cause the NAND gate at the S input to have an H output, forcing the flip-flop to the H state (again provided the R input is kept H).

If both inputs R and S are made L's, the next state will depend on which input is returned to H first, and if both are returned to H simultaneously, the resulting state of the flip-flop will be indeterminate. As a result, this is a "forbidden" or "restricted" input combination.

In the actual use, the activation speed of the flip-flop is managed to be delayed in order to prevent erroneous movements caused by noise as shown in Fig. 2.3.11.

Truth Table 3

Set	Reset	Q	\bar{Q}	Remarks
L	L	H	H	*: Maintains the previous state.
L	H	H	L	
H	L	L	H	
H	H	*	*	

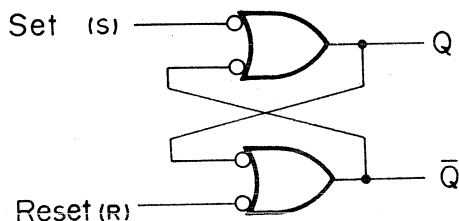

Fig. 2.3.10

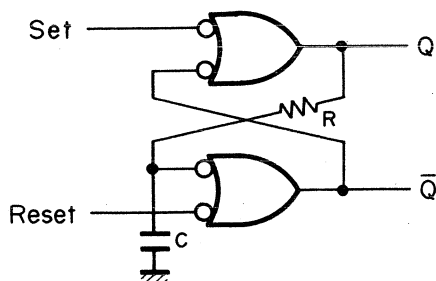

Fig. 2.3.11

(d) Compatible C-MOS ICs

IC401, 402, 403: μ PD4011C, CD4011A, MC14011A, F34011A, TP4011A, TC4011P

IC404: μ PD4001C, CD4001A, MC14001A, F34001A, TP4001A, TC4001P

(2) Logic Control and Other Circuits

A foolproof operation will be done by logic control. For example, when command the playback mode while fast winding or command fast-forward mode while rewinding, it is guaranteed that no abnormal tape tension will happen by passing through the stop mode. This is also guaranteed even when the switches are pressed simultaneously.

(a) Logic Signal

How to read signals is referred to the following:

Positive logic is used; the signal H shows the condition that the signal is executing, and in case there is a - on the signal, signal L shows the condition that the signal is executing.

- 1) \overline{Kstop} (Stop switch output signal)
 \overline{Kstop} becomes L when the Stop switch is pressed, and $Kstop$ is H while switch is open.
 In other words, $Kstop = L$ shows while Stop mode is commanded, and $\overline{Kstop} = H$ shows stop is not commanded.
- 2) \overline{PLAY} (Play Flip-Flop \bar{Q} output signal)
 $\overline{PLAY} = H$: out of Play mode
 $\overline{PLAY} = L$: in Play mode
- 3) $PLAY$ (Play Flip-Flop Q output signal)
 $PLAY = H$: in Play mode
 $PLAY = L$: out of Play mode

(b) Logic Operating Status

Refer to Fig. 2.3.12 (Logic Status).

Each stage of logic status under the series control switch operation is shown in the figure.

(c) Conditions of Flip-Flops

- 1) FF Flip-Flop
 $Set = \overline{Kff}$
 $Reset = \overline{Kplay} + \overline{Krew} + \overline{Kstop}$
- 2) REW Flip-Flop
 $Set = \overline{Krew}$
 $Reset = \overline{Kplay} + \overline{Kff} + \overline{Kstop} + \overline{Memory\ Rewind}$
 (Memory Rewind = L: With Memory switch ON, a differential L pulse generates when the tape counter reaches "999".)
- 3) $PLAY$ Flip-Flop
 $Set = \overline{Kplay}$
 $Reset = \overline{Kff} + \overline{Krew} + \overline{Kstop} + \overline{PAUSE}$

4) PAUSE Flip-Flop

Set = $\overline{K_{pause}}$

Reset = $\overline{K_{play}} + \overline{K_{stop}} +$ (the rising of the FAST signal)

(FAST = FF + REW. When FAST signal becomes H, a differential pulse is generated at the rising of the signal. This pulse conducts Q404 to turn ON, accordingly PAUSE Flip-Flop is reset.)

5) REC Flip-Flop

Set = $\overline{K_{rec} \cdot FAST \cdot PAUSE \cdot PLAY \cdot Record Protector Switch OFF}$

= $\overline{K_{rec} \cdot FAST \cdot Q405 OFF}$

(Q405 OFF = $\overline{PAUSE \cdot PLAY \cdot Record Protector Switch OFF}$)

Reset = $\overline{PLAY \cdot PAUSE} = Q406 ON$

MODE	STOP	RECORD				PLAY-BACK	FAST WIND		CUE	
CONTROL SWITCH	STOP	RECORD	RECORD PAUSE	PLAY	PAUSE	PLAY	FF	REW	PAUSE	
	L	L	L	H	L	H	L	L	L	
	H	H	H	L	H	L	H	H	H	
	L	H	H	H	H	L	L	L	L	
	H	H	L	H	L	H	H	H	L	
	L	L	L	L	L	L	L	H	H	
\overline{REC} (Q421 Collector)	H	H	L	L	L	H	H	H	H	
MUTE (Q424 Collector)	H	H	L	L	L	L	H	H	L	
\overline{CUE} (Q426 Collector)	H	H	H	H	H	H	H	H	L	

Fig. 2.3.12 Logic Status

(d) Initial Reset and Power Mute

Refer to Fig. 2.3.13 circuit diagram and Fig. 2.3.14 timing chart.

When the power switch is turned ON, the voltage of the power source increases from 0 to +12 V DC. After this voltage is built up, Q403 is turned ON and the mute signal is generated, until C402 is charged through R404, R405, and R406. At the same time, this signal enters the base of Q417 in the automatic shut-off circuit, and turns this transistor ON so that it generates $\overline{Kstop} = L$ pulse.

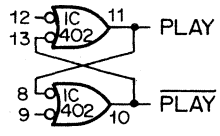
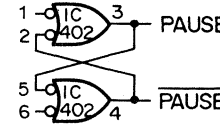
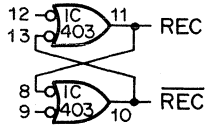
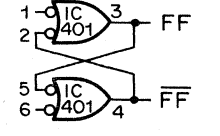
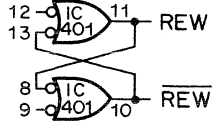
When the power switch is turned OFF, the signal from the secondary winding of the transformer entering Q401 soon ceases and Q401 is in the cutoff state. Since the base of Q402 is positively charged, Q402 comes ON, which turns Q403 ON and produces the $\overline{Kstop} = L$ pulse. The $\overline{Kstop} = L$ pulse resets each flip-flop to its initial condition (the stop condition).

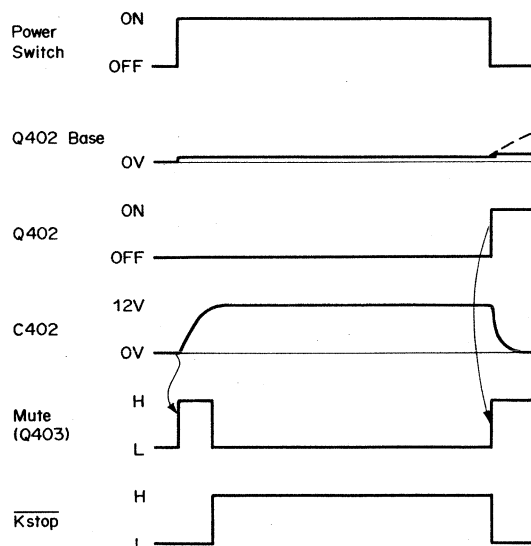

Fig. 2.3.14 Timing Chart

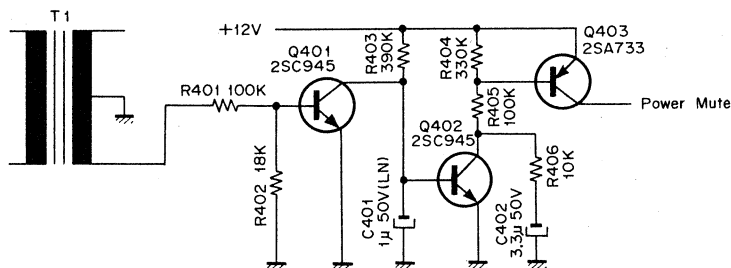

Fig. 2.3.13 Initial Reset and Power Mute Circuit

(e) One-shot Pulse-generating Circuit

Refer to Fig. 2.3.15 circuit diagram and Fig. 2.3.16 timing chart.

The circuit consists of IC403-4,5, and 6, IC403-1, 2, and 3, Q407, R420, R421, C412, etc. When the mode is changed as shown below, the circuit generates a one-shot pulse of approximately 400 msec, so that this period passes in the stop mode, and as soon as this is over, a new mode is set:

- From FAST (FF or REW) mode to PLAY or PAUSE mode;
- From PLAY mode to FAST (FF or REW) mode;
- From FF mode to REW mode, or vice versa.

This interval is necessary to avoid an extraneously large tension on the tape, in view of the response of the tape deck mechanism.

1) From PLAY mode to FF mode

Since the PLAY flip-flop is set during playing, IC403-6 is H and IC403-5 is L, and therefore, IC403-4 is H and C412 is charged to +12 V. Consequently, IC403-3 is L, and the gates connected to IC403-3 are open.

When the FF switch is pressed the PLAY flip-flop is reset, and at the same time, the FF flip-flop is set. However, the capacitor C413 connected to the PLAY flip-flop retards

so that PLAY = L. Therefore, FF = H and PLAY = H for a short period, and a narrow pulse is produced in IC403-4. C412 is discharged by this L pulse, but it is charged again through R420 and R421 when the L pulse is released. IC403-3 is maintained at H for approximately 400 msec, until the voltage of C412 exceeds the threshold of IC403-1 and 2, and the gates connected to IC403-3 are closed to bring about the stop condition.

2) From FF mode to REW mode

When the REW switch is pressed, the FF flip-flop is reset, and the REW flip-flop is set. As in case 1), a narrow H pulse is generated in the base of Q407, cutting off Q407, and as a result, C412 is discharged through D411. The subsequent actions are the same as in 1).

(g) REC Signal

Refer to Fig. 2.3.18. This is the signal that controls bias oscillation in the amplifier circuit. In RECORD/PLAY and RECORD/PAUSE modes, REC = L, and bias oscillation is started. Q421 is turned ON when the REC flip-flop is H and Q422 is OFF, i.e., when the cam selects PLAY or PAUSE mode mechanically, and REC = L.

(h) CUE Signal

Refer to Fig. 2.3.18. When the PAUSE switch is pressed during the FAST (FF or REW) mode, CUE = L, and the output level of the amplifier circuit is attenuated. Q426 is turned ON at FAST/PAUSE, thus CUE = L.

(i) Mute Signal

Refer to Fig. 2.3.18. When Q424 is ON and when the Mute-power is H through D434, MUTE = H and the amplifier circuit is muted.

$$Q424 \text{ ON} = Q423 \text{ OFF} (= \overline{\text{CUE} \cdot \text{REC}}) \cdot (\text{STOP} + \text{PAUSE} + Q425 \text{ ON} (\text{PLAY-Position}))$$

The modes in which the amplifier circuit is not muted are (MUTE = L):

$$Q424 \text{ OFF} = \overline{Q424 \text{ ON}} = \overline{\text{CUE} + \text{REC} + \text{STOP} \cdot \text{PAUSE} \cdot \text{PLAY-Position}}$$

i.e., the FAST/PAUSE (i.e., CUE) mode, RECORD or RECORD/PAUSE mode, and PLAYBACK mode.

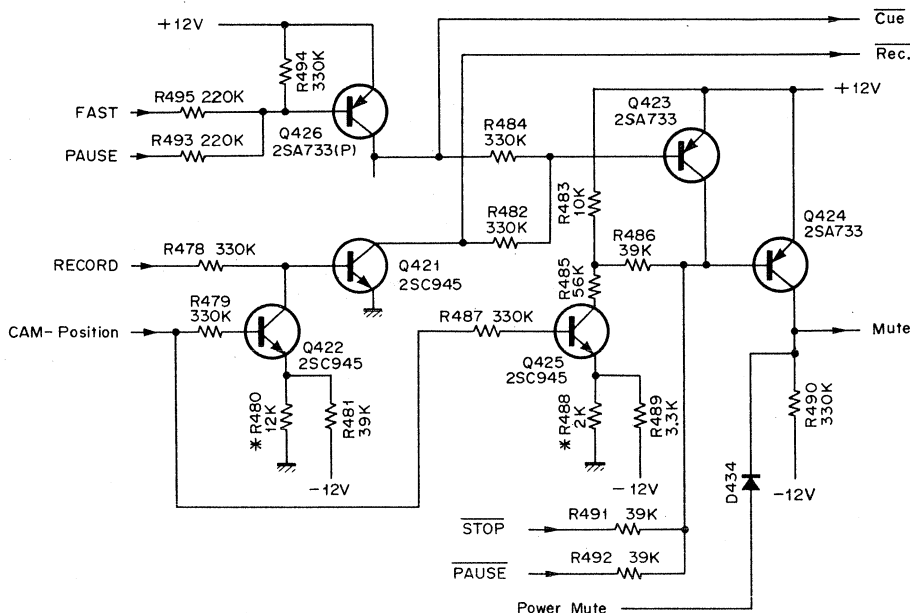

Fig. 2.3.18

(j) Take-up Function at Loading

Refer to Fig. 2.3.19. SW503 Eject Switch is closed when eject is made. When a cassette tape is inserted into the Cassette Case Ass'y and loaded, SW503 will become open. Therefore, plus voltage is applied at No. 2 pin of IC405 until C428 (4.7μF 25V) is charged up through R524 (2.2 MΩ).

Accordingly Reel Motor rotates forwardly and eliminates tape loosening of the cassette tape if any.

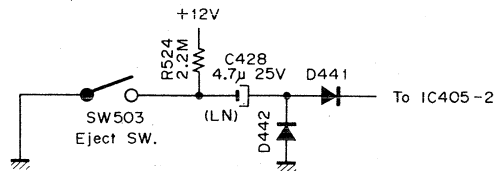

Fig. 2.3.19

2.3.2. Shut-off Sensor and Detector

Refer to Fig. 2.3.20 circuit diagram and Fig. 2.3.21 timing chart.

(1) Shut-off sensor

Light from lamp PL501 is projected through holes in a disc rotating synchronously with the take-up reel, and the intermittent flashes coming through the disc are converted into electrical signals by a phototransistor (Q602). These signals are amplified into square waves, and transmitted to the shut-off detector in the subsequent stage. When the tape-end comes, the take-up reel and the disc stop rotating, and no pulse is output from the sensor.

(2) Shut-off detector

The shut-off detector, which receives the pulse output from the sensor, produces the shut-off signal (i.e., $\overline{Kstop} = L$) having detected a certain period of absence of pulse, and this signal resets each flip-flop in the logic control circuit.

- (a) Through C421, Q416 is ON and discharges C422 at every H cycle of the sensor output pulse. On the other hand, C422 (1 μ F) is charged through R461 (2.2 M Ω) in the PLAY (Playback or Record) mode or the FAST (FF or REW) mode.
- (b) At the end of the tape, no sensor output is produced and Q416 is not turned ON, resulting in C422 being charged continuously. When the voltage of C422 exceeds the sum of the emitter voltage (approx. 1.1 V) and the VBE of Q417, Q417 is turned ON and transmits the shut-off signal ($\overline{Kstop} = L$) to the logic control circuit.

- (c) In the STOP mode, C422 is grounded through D426 and R459, and the shut-off detection function is made inoperative. When PAUSE switch is pressed, C422 is discharged through D437.
- (d) Q417 is turned ON by the mute-power signal generated whenever power is turned ON or OFF, and produces the $\overline{Kstop} = L$ pulse.

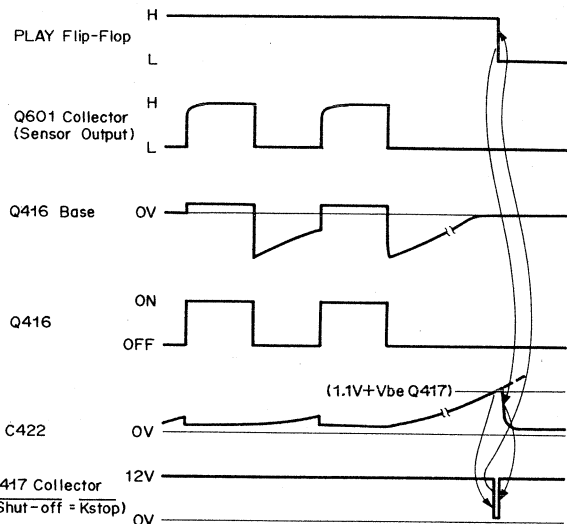

Fig. 2.3.21 Timing Chart

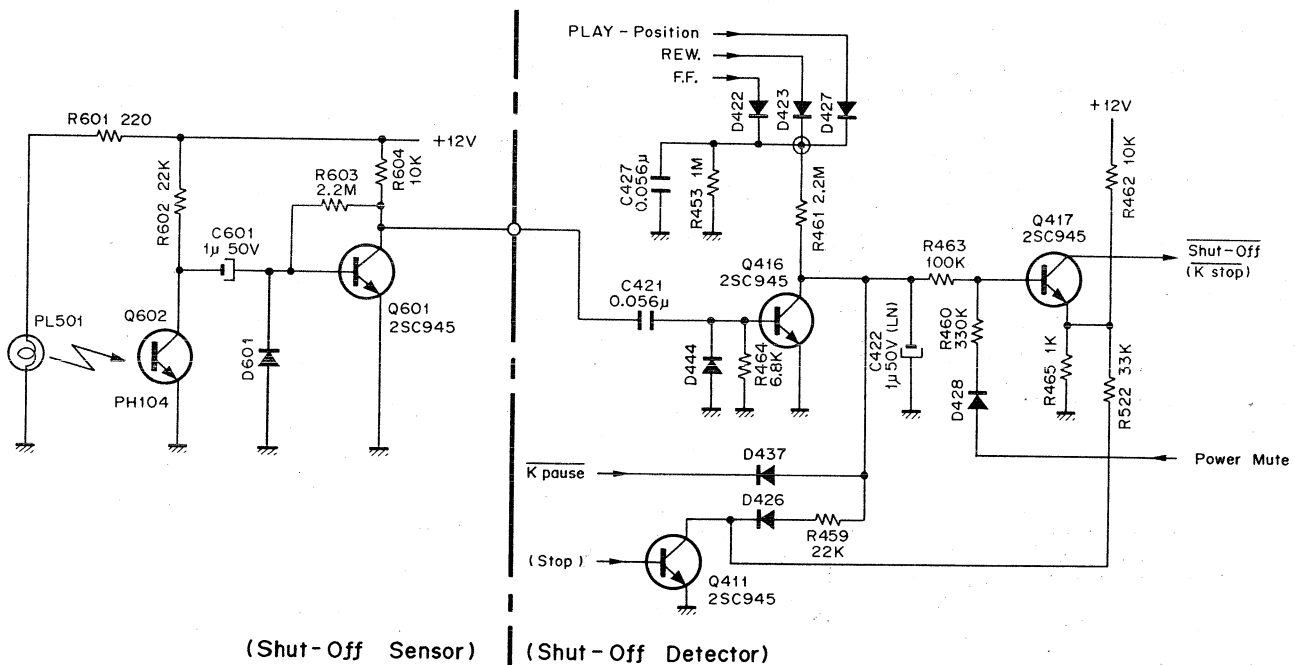

Fig. 2.3.20 Shut-OFF Sensor and Detector Circuit

2.3.3. Control Motor Drive Circuit

Refer to Fig. 2.3.22 circuit diagram and Fig. 2.3.23 timing chart for the series control switch operation. The control motor is turned by varying amounts, according to which control switch is set. This motor is connected to the mechanism control cam, and the mechanism of the N-580M is set to the mode indicated by this cam. The motor is driven by the differential amplifier (IC405) and drivers Q431 and Q432. When the motor has stopped, the voltage at the sliding contact of the cam control variable resistor moving synchronously with the motor (control voltage) is balanced with the reference voltage corresponding to each mode, and the input difference of the differential amplifier is zero. When a new mode is demanded, a different reference voltage breaks the balance at the differential amplifier, and the motor operates.

The motor drives the cam control variable resistor and changes the control voltage. When the control voltage is changed and the input difference of the differential amplifier becomes zero, the motor stops.

The following table shows the position of the cam and the voltage at the sliding contact of the cam control variable resistor:

Position on Cam	Voltage at Sliding Contact of Cam Control Volume
Stop	3.0 V
Rec	4.1 V
FF/REW	1.3 V
Pause	-2.8 V
Play	-5.4 V
Cue	-0.4 V

State of transistors in each mode:

- STOP: Q427, Q428, Q429, Q430 OFF
- PLAY: Q429 ON
- FF/REW: Q428, Q430 ON
- REC: Q427, Q430 ON (in the form of pulse)
- PAUSE: Q429 ON
- CUE: Q428, Q429, Q430 ON

RECORD mode

When RECORD switch and PLAY switch are pressed, Q427 pulses ON and OFF through C426, and the cam moves to the RECORD position. Then cam moves to the PLAY position and stays there, thus the mechanism is set to the RECORD mode.

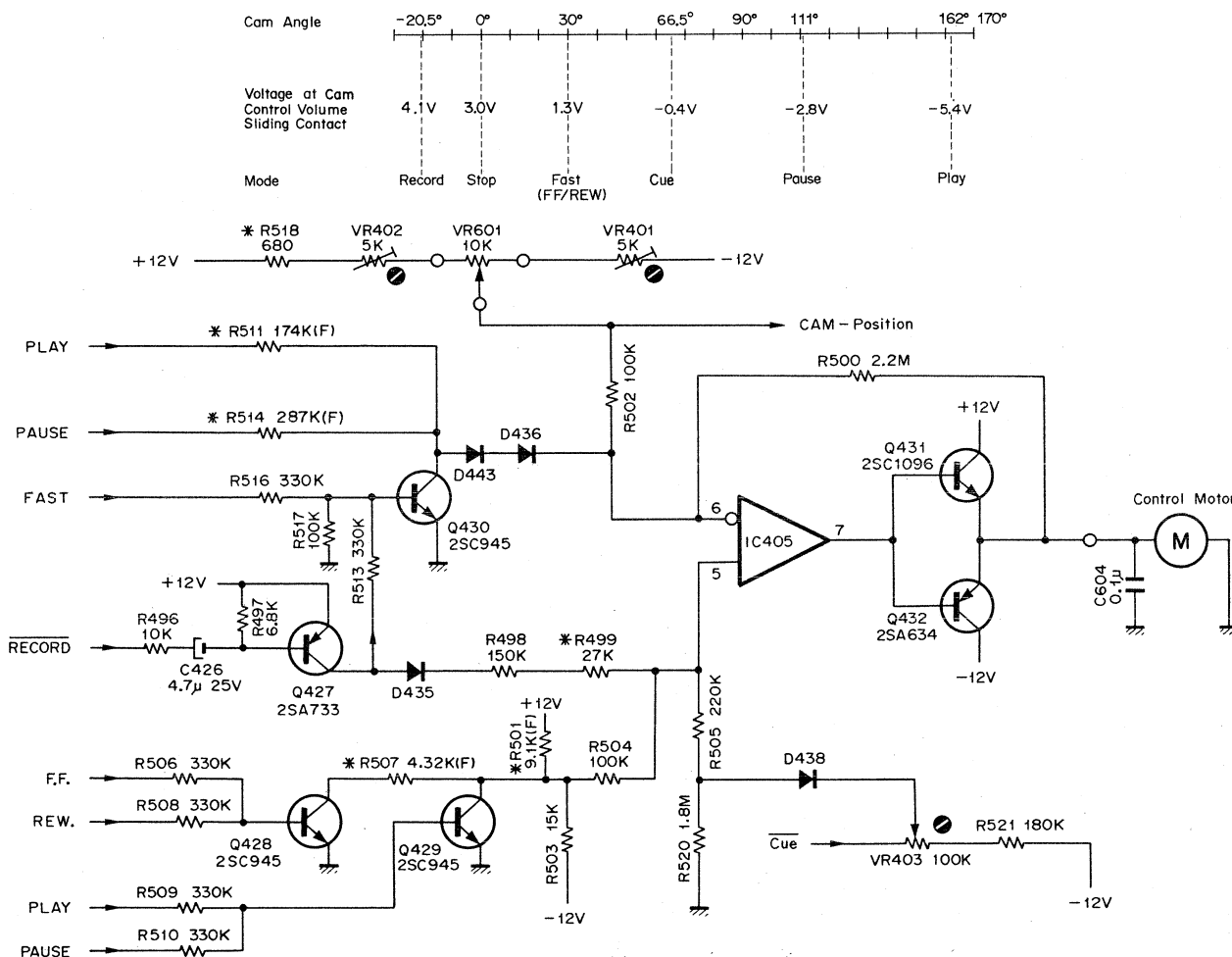

Fig. 2.3.22 Control Motor Drive Circuit

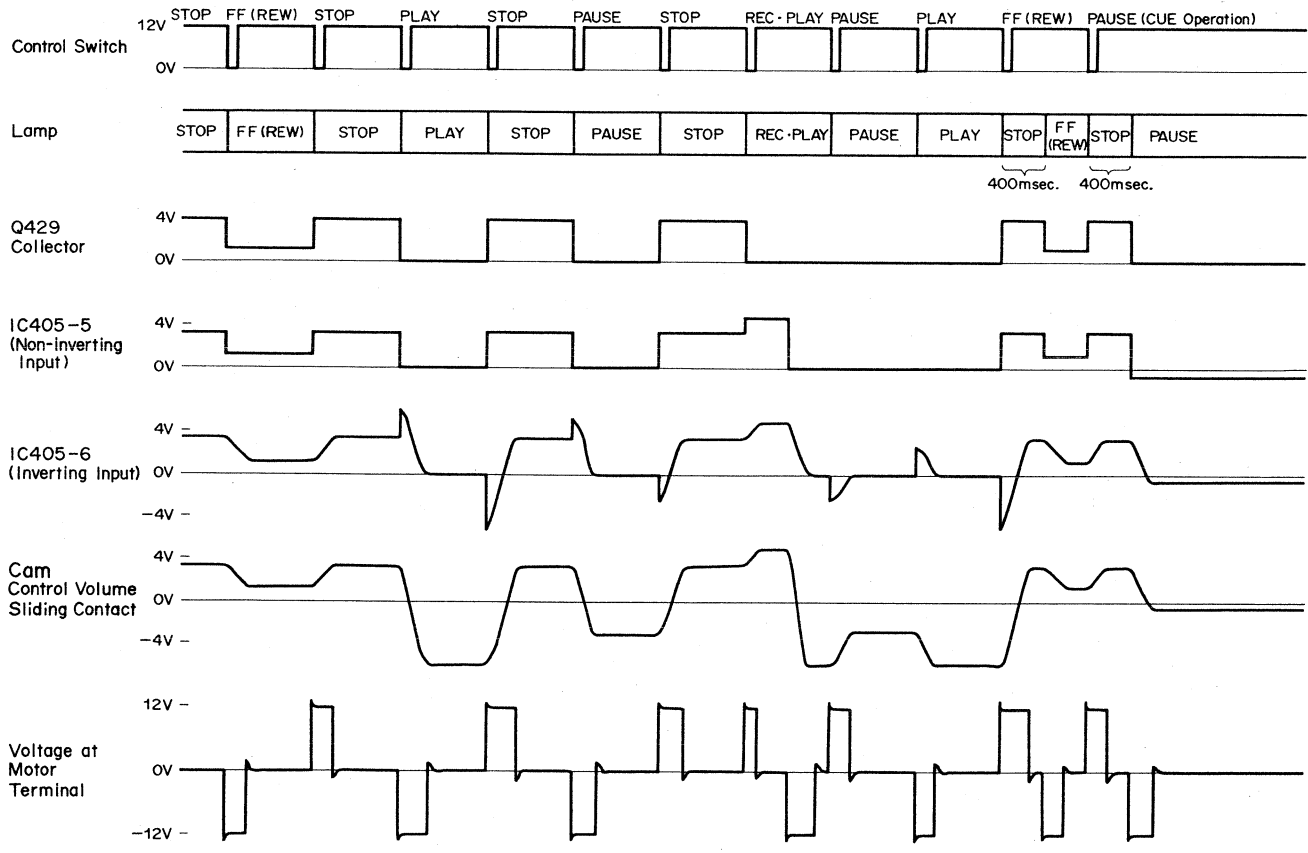

Fig. 2.3.23 Timing Chart

2.3.4. Capstan Motor Governor

This is a governor employing a PLL (phase-locked loop) IC, and drives the capstan motor at a constant speed when the power switch is turned ON.

2.3.5. Reel Motor Governor

Refer to Fig. 2.3.24 circuit diagram and Fig. 2.3.25 timing chart.

This is a governor controlling the reel motor speed and it consists of a differential amplifier, IC405, and motor drivers, Q419 and Q420, etc. The speed of the motor varies as follows:

(1) PLAY

Q418 is ON and IC405-2 (inverting input) is supplied with a positive voltage, and Q420 is conducted. The motor is kept running at a constant speed by the governor.

(2) FF or REW

A positive voltage is supplied to IC405-2 in the FF mode, when Q420 is saturated, and in the REW mode, to IC405-3 (non-inverting input), when Q419 is saturated. Therefore, the governor function does not operate and the motor turns forward or in reverse, depending on whether is supplied with an approximately -12 V or +12 V voltage.

(3) PAUSE switch pressed during FF or REW (i.e., CUE)

Q413 is turned ON and the input voltage to IC405 is decreased, and the motor speed is reduced to approx. 1/3 of that for FF or REW. The motor is kept running at a constant speed by the governor.

(4) FF or REW switch kept further pressed in state (3)

Since R477 is grounded through D431 or D432, the input voltage to IC405 is further decreased, and the motor speed is reduced to approx. 3/5 of that for CUE (approx. 1/5 of that for FF or REW).

The motor is kept running at a constant speed by the governor.

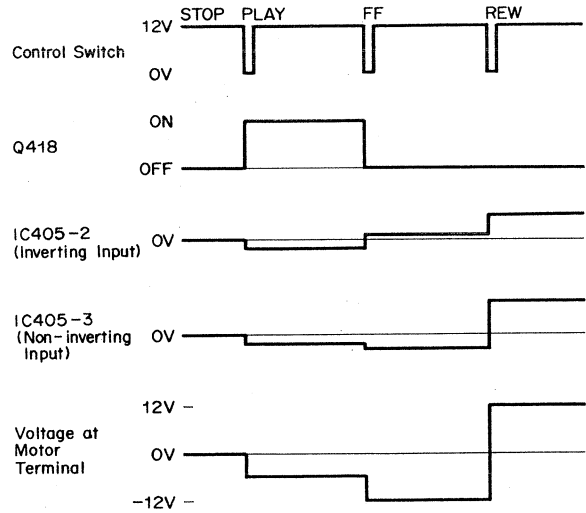

Fig. 2.3.25 Timing Chart

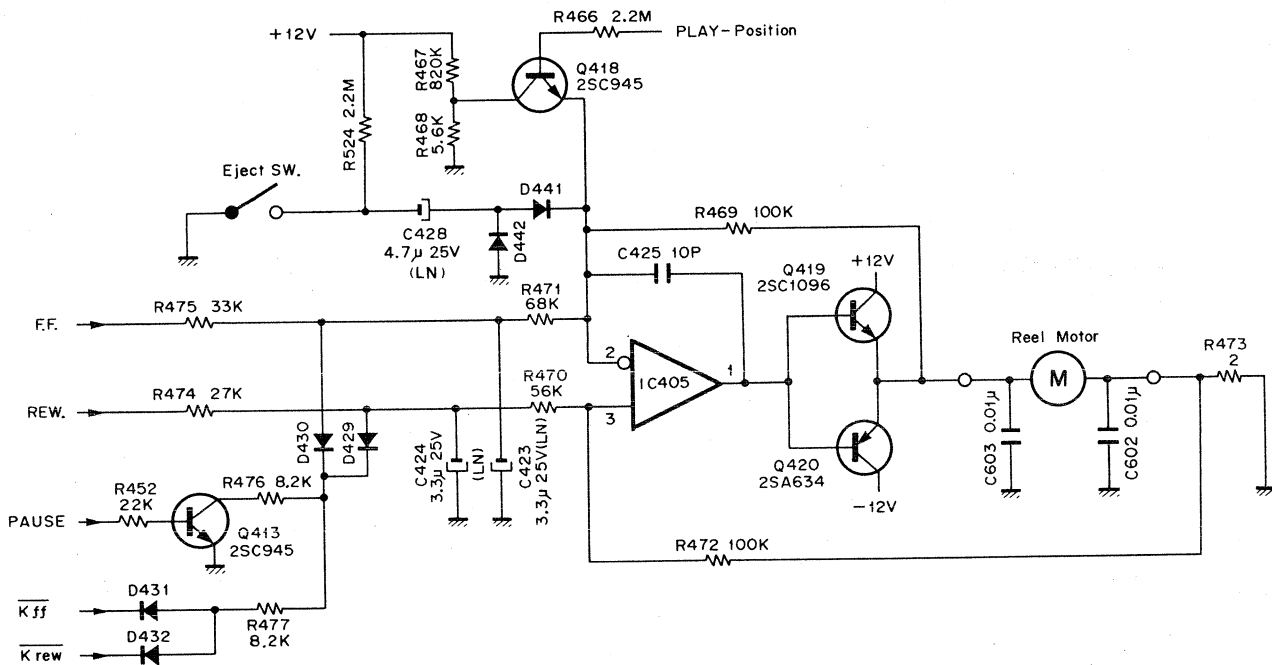

Fig. 2.3.24 Reel Motor Drive Circuit

2.4. Remote Control Unit RM-580 (Optional)

2.4.1. Introduction

The RM-580 is a remote controller for the N-580M consisting of a transmitter and a receiver. The transmitter transmits infrared control information which is received by a photosensitive diode in the receiver. The information is amplified and transmitted to the N-580M in order to control the tuning, volume, power supply and the auto-tuning of the N-580M. See Fig. 2.4.1.

The control information is in the form of pulses with a frequency of approx. 22 kHz, transmitted with infrared rays.

Each unit of information consists of 7 bit and is transmitted in 10.5 ms. The first of the 7 bit is the start bit, the others being information bit. There is a time interval of 164 ms between each 7-bit unit of information and the next. See Fig. 2.4.2.

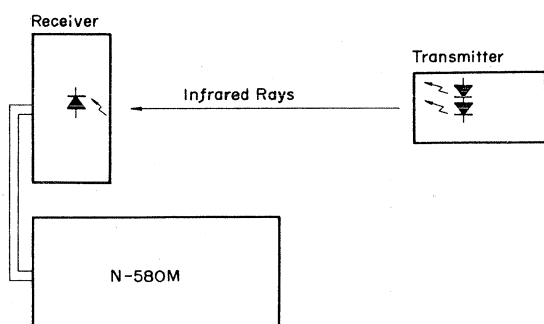

Fig. 2.4.1 RM-580 Connecting Diagram

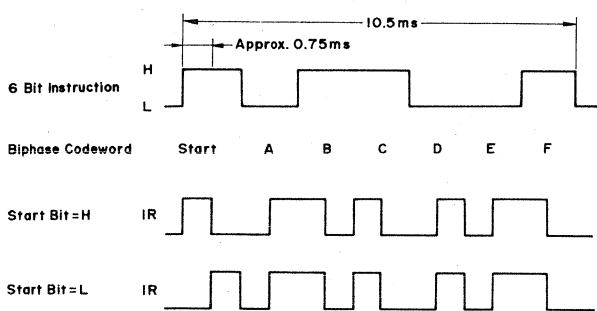

Fig. 2.4.2 Information Unit

2.4.2. Transmitter

The transmitter consists of a matrix key having various operation switches, a system IC for transmission, and an LED driving unit. See Fig. 2.4.3.

(1) Matrix key

The matrix key consists of six microswitches and six transistors: play, stop, rewind, f.f., record and pause.

(2) System IC for transmission

The system IC for transmission consists of IC901, the turn-ON transistor Q908, and an additional clock generator circuit.

Terminal No. 1 is connected to a positive power source and Terminal No. 6 is grounded through Q908. Since a battery is used in the RM-580 it is designed so that the power is consumed only when the matrix key is depressed and the information is transmitted.

When one of 1 to 8 and one of a to d of the keyboard scanning section of IC901 are shortcircuited, the turn-ON control section within the IC causes the voltage level at Terminal 7 of IC901 to become H. Then, Q908 is turned ON. Terminal 6 of IC901 is grounded, and the information is given from Terminal 8 through the output section. Terminals 2 to 5 correspond to a to d, and Terminals 9 to 16 correspond to 1 to 8 of the keyboard scanning section. If 1 and a of the keyboard scanning section are shortcircuited, a unit of information is generated, and if 1 and b are shortcircuited, another unit of information is generated. Thus, 32 kinds of information can be obtained from Terminal 8 through the output section. The external circuit of the clock generator used to make the pulses for information transmission is connected to Terminals 17 and 18 of IC901. The frequency is determined by the adjustment of L901.

(3) LED driver

The LED driver consists of Q909 and Q910 connected to Terminal 8 of IC901, and photodiodes D907 and D908. It converts the output information into infrared signals having considerable power.

The signal from Terminal 8 of IC901 becomes the base current of Q909 whose collector current is the base current of Q910 and the collector current from Q910 flowing to LED's D907 and D908 acts to transmit the information. D904, D905, D906, R925 and R926 compose a protective circuit to restrict the current to the LED's.

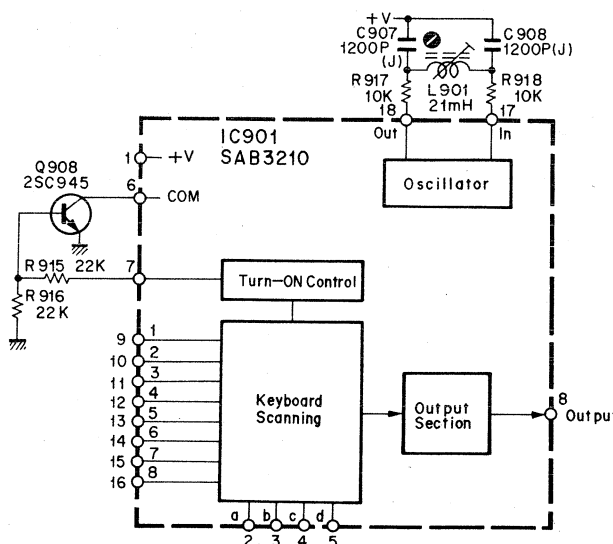

Fig. 2.4.3 Transmission IC System Diagram

2.4.3. Receiver

The receiver consists of a signal input, a signal amplifier, a system IC for reception, an instantaneous system IC power-disconnecting switch, a buffer amplifier, and an information processor.

(1) Signal input

The signal input consists of a photodiode D001, a transistor Q001 and a parallel resonance circuit.

The infrared signal radiated from the transmitter is received by the photodiode D001 and converted into a current. The current is amplified in the parallel resonance circuit consisting of C001, L001 and R001, and is further amplified by Q001.

The parallel resonance circuit is the most important part for remote control, and determines the distance at which remote operation is possible. This distance can be varied greatly by adjusting L002.

(2) Signal amplifier

The signal amplifier consists of IC004 and the surrounding circuits. IC004 is a specific frequency amplifier, operating at the information propagation frequency of approx. 22 kHz with an amplification of about 100 dB. This frequency is determined by R004, R005, R006, C004, C005 and C006.

(3) System IC for reception

The system IC for reception is IC003 shown in Fig. 2.4.4. Terminal 1 of IC003 is supplied with a positive power source and Terminal 17 is grounded. IC003 has a built-in clock-generator. An additional circuit is connected to Terminals 2 and 3 in order to make a frequency identical to that of the transmitter. The frequency can be adjusted by L002. The information signal from the transmitter is amplified by the signal amplifier and input at Terminal 15 of IC003. It is processed by a read-in register, and an output corresponding to the input is produced through program portion. Since the program portion has 4 kinds of output (A, B, C and D), 16 ($2^4 = 16$) kinds of output

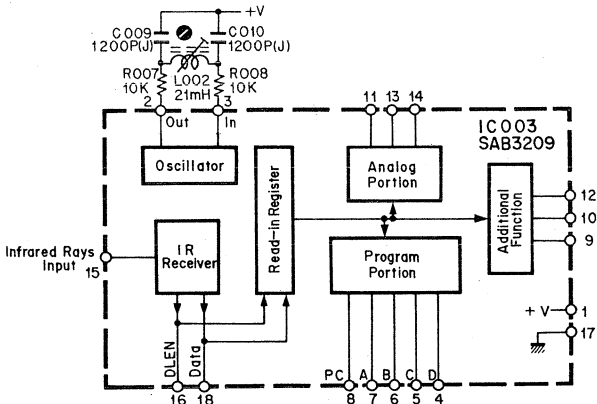

Fig. 2.4.4 Reception IC System Diagram

are produced. Terminal 8 of IC003 is called the PC terminal and is H only when an information signal is input.

(4) Instantaneous power-disconnecting switch function

See Fig. 2.4.5 timing chart.

The instantaneous power-disconnecting switch function for the system IC for reception consists of Q002, Q003, IC001-1,2,3, -4,5,6 and their peripheral circuit IC003 maintains its state when an information signal is output from the program portion, until the next unit of information is input. However, since the maintenance of this state affects the functioning of N-580M, the information stored in the program portion must be cleared when the remote control button is released, and it is for this reason that the switching function of instantaneous power-disconnecting is provided to disconnect the power supply to IC003 and to clear the memory.

When an infrared signal is input through Terminal 15 of IC003, signal as shown in the figure are produced at Terminal 8, and fed into the base of Q002, as a result Q002 is turned ON.

The output signal of Q002 is given to the base of Q003 through inverters IC001-4,5,6 and -1,2,3. Q003 controls the power supply to IC003. When Q003 is turned ON, +12 V will be supplied to IC003, but when turned OFF, +12 V will no longer be supplied.

When a unit of information is finished, Q002 will not be turned ON, as a result C012 will be kept charging.

When the voltage of C012 exceeds the threshold level of IC001-5,6 (approximately half of applied +12 V), IC001-4 will become L and IC001-3 will become H. This way, H level is applied to the base of Q303 through C013, as a result Q003 will be turned OFF momentarily to disconnect the power supply to IC003, so that the program stored in IC003 will become cleared.

(5) Information processor

The information processor of C-MOS ICs IC001-8,9,10, -11,12,13, IC002-1,2,3, -4,5,6, -8,9,10, -11,12,13, Q004, Q005 and their peripheral circuits. It processes the 4-bit output signals from IC003 input as infrared information signals.

The table of information transmitted and the corresponding 4-bit signals output from IC003 is as follows:

Information	Signal Bit			
	A(7)	B(6)	C(5)	D(4)
Play	L	H	L	H
Stop	L	H	H	L
Rewind	H	L	H	L
F.F.	H	H	L	L
Record	L	L	H	H
Pause	H	L	L	H

As shown in the above table, there are 6 kinds of information to be transmitted, and when power source and grounding are included, 8 bus lines are required. Each command will be output to Logic P.C.B. Ass'y of the N-580M as shown below:

(a) Play

When both IC002-5 (B) and -6 (D) are made H's, IC002-4 becomes L and D005 is turned ON, as a result $\overline{\text{Play}} = \text{L}$ signal is output and Play will be activated.

(b) Stop

When both IC002-12 (B) and -13 (C) are made H's, IC002-11 becomes L and D003 is turned ON, as a result $\overline{\text{Stop}} = \text{L}$ signal is output and Stop will be activated.

(c) Rewind

When both IC001-8 (A) and -9 (C) are made H's, IC001-10 becomes L and D007 is turned ON, as a result $\overline{\text{Rewind}} = \text{L}$ signal is output and Rewind will be activated.

(d) F.F. (Fast Forward)

When both IC002-1 (A) and -2 (B) are made H's, IC002-3 becomes L and D006 is turned ON, as a result $\overline{\text{F.F.}} = \text{L}$ signal is output and F.F. will be activated.

(e) Pause

When both IC002-8 (D) and -9 (A) are made H's, IC002-10 becomes L and D004 is turned ON, as a result $\overline{\text{Pause}} = \text{L}$ signal is output and Pause will be activated.

(f) Record

When both IC001-12 (C) and -13 (D) are made H's, IC001-11 becomes L, and Q004 is turned ON, and then Q005 is turned ON with a certain time delay through C015, as a result $\overline{\text{Record}} = \text{L}$ is output and Record will be activated.

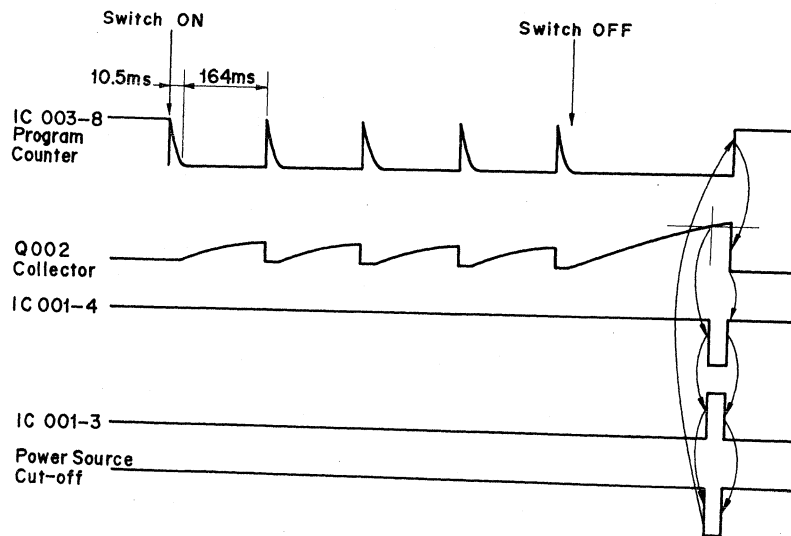

Fig. 2.4.5 Timing Chart

3. REMOVAL PROCEDURES

3.1. Acrylic Cassette Compartment Cover

Refer to Fig. 3.1.

- (1) Press the Eject Button to open the Cassette Case Ass'y.
- (2) Pull out F01 (Acrylic Cassette Compartment Cover) upward.

3.2. Top Cover Ass'y

Refer to Fig. 3.1.

Remove F02 and F03, then disassemble F04 (Top Cover Ass'y).

3.3. Bottom Cover Ass'y

Refer to Fig. 3.1.

Remove F05, then disassemble F06 (Bottom Cover Ass'y).

3.4. Front Panel Ass'y

Refer to Fig. 3.2.

- (1) Refer to Fig. 3.1. Remove Top Cover Ass'y and Bottom Cover Ass'y referring to items 3.1 and 3.2.
- (2) Remove F01 (Volume Knob) by pushing with a screwdriver or similar tools from the inside of the N-580M.
- (3) Remove F02, then disassemble F03 (Front Panel Ass'y including 2 connectors).

3.5. Mechanism Ass'y

Refer to Fig. 3.2.

- (1) Remove Front Panel Ass'y referring to item 3.4.
- (2) Remove F04, then disassemble F05 (Headphone Jack Ass'y).
- (3) Remove F06, then disassemble F07 (Mechanism Ass'y including 2 connectors and a Record Switch Linkage).

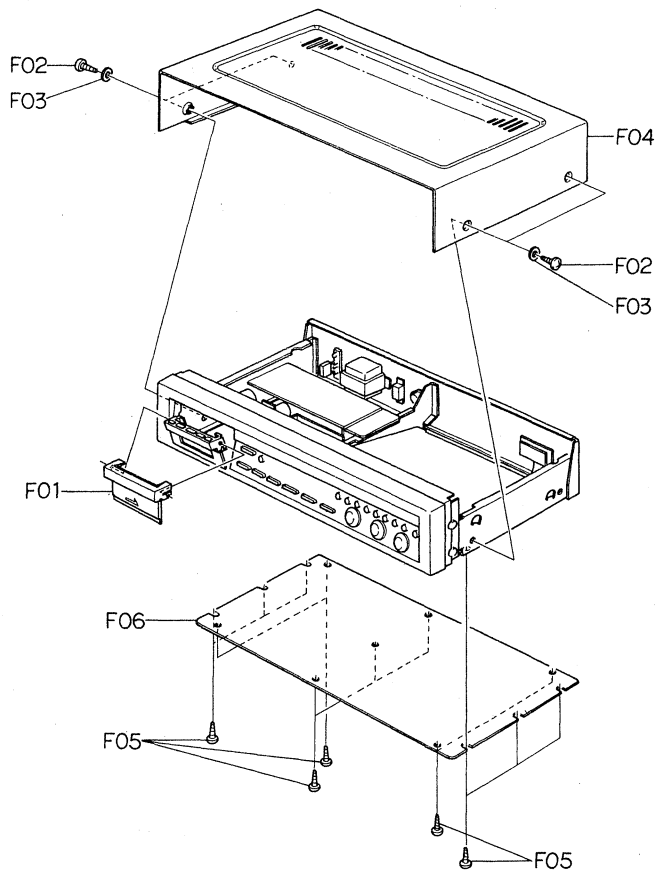

Fig. 3.1

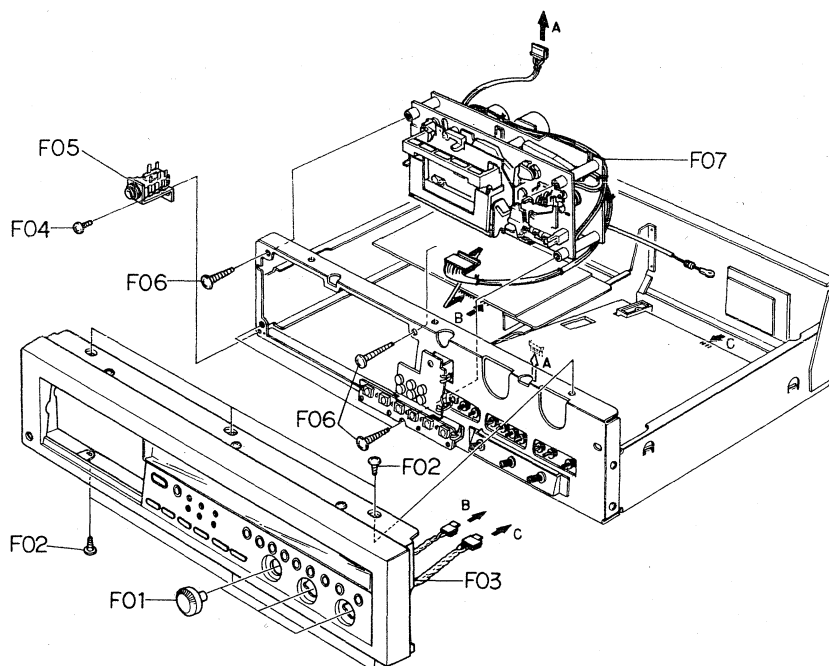

Fig. 3.2

3.6. Main P.C.B. Ass'y

Refer to Fig. 3.3.

- (1) Refer to Fig. 3.2. Remove Front Panel Ass'y referring to item 3.4.
- (2) Remove the Flat Cable and wires connected by wrapping from the F04 (Main P.C.B. Ass'y).
- (3) Remove F01, F02, F03 and the Record Switch Linage from the Wire Holder assembled with Record Switch, then disassemble F04 (Main P.C.B. Ass'y).

3.7. Logic P.C.B. Ass'y

Refer to Fig. 3.3.

- (1) Refer to Fig. 3.2. Remove Front Panel Ass'y referring to item 3.4.
- (2) Remove the connector and the wires connected by wrapping from the F06 (Logic P.C.B. Ass'y).
- (3) Remove F05, then disassemble F06 (Logic P.C.B. Ass'y).

3.8. Power Switch

Refer to Fig. 3.3.

- (1) Refer to Fig. 3.3. Remove Main P.C.B. Ass'y referring to item 3.7.
- (2) Remove F07, then disassemble F08 (Power Switch).

3.9. Volume P.C.B. Ass'y

Refer to Fig. 3.3.

- (1) Refer to Fig. 3.2. Remove Front Panel Ass'y referring to item 3.4.
- (2) Remove F09, then disassemble F10 (Volume P.C.B. Ass'y).

3.10. Control Switch P.C.B. Ass'y

Refer to Fig. 3.3.

- (1) Refer to Fig. 3.2. Remove Front Panel Ass'y referring to item 3.4.
- (2) Remove F11, then disassemble F12 (Control Switch P.C.B. Ass'y).

3.11. Record Cal. P.C.B. Ass'y

Refer to Fig. 3.3.

- (1) Refer to Fig. 3.2. Remove Front Panel Ass'y referring to item 3.4.
- (2) Remove F13, then disassemble F14 (Record Cal. P.C.B. Ass'y).

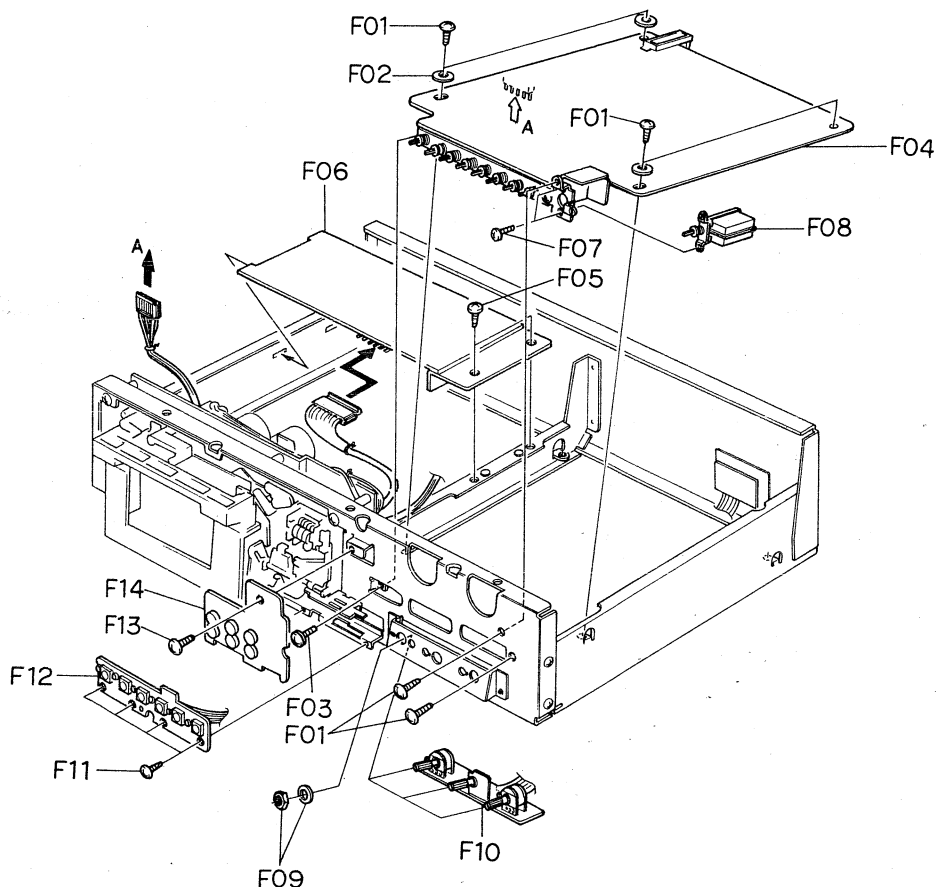

Fig. 3.3

3.12. Meter Ass'y

Refer to Fig. 3.4.

- (1) Refer to Fig. 3.2. Remove Front Panel Ass'y referring to item 3.4.
- (2) Remove F01 and F02, then disassemble F03 (Meter Ass'y).

3.13. Lamp P.C.B. Ass'y

Refer to Fig. 3.4.

- (1) Remove Meter Ass'y referring to item 3.12.
- (2) Remove F04, then disassemble F05 (Lamp House Cover Ass'y)
- (3) Remove F06, then disassemble F07 (Lamp P.C.B. Ass'y).

3.14. Aluminum Mirror

Refer to Fig. 3.4.

- (1) Remove Lamp House Cover Ass'y referring to item 3.13.
- (2) Remove F08, then disassemble F09 (Aluminum Mirror).

3.15. Rear Panel Ass'y

Refer to Fig. 3.5.

- (1) Refer to Fig. 3.1. Remove Top Cover Ass'y and Bottom Cover Ass'y referring to items 3.2 and 3.3.
- (2) Remove F01, F02 and F03, then disassemble F04 (Rear Panel Ass'y).

3.16. Power Transformer

Refer to Fig. 3.5.

- (1) Refer to Fig. 3.1. Remove Top Cover Ass'y and Bottom Cover Ass'y referring to items 3.2 and 3.3.
- (2) Remove F05, F06 and F07, then disassemble F08 (Power Transformer).

3.17. Cassette Case Ass'y

Refer to Fig. 3.6.

- (1) Refer to Fig. 3.2. Remove Mechanism Ass'y referring to item 3.5.
- (2) Push the Eject Button to open the Cassette Case Ass'y.
- (3) Remove F01 then disassemble the Piston of the Pneumatic Damper Ass'y.
- (4) Remove F02 and F03 (Cassette Case Holder L Ass'y), then disassemble F04 (Cassette Case Ass'y).

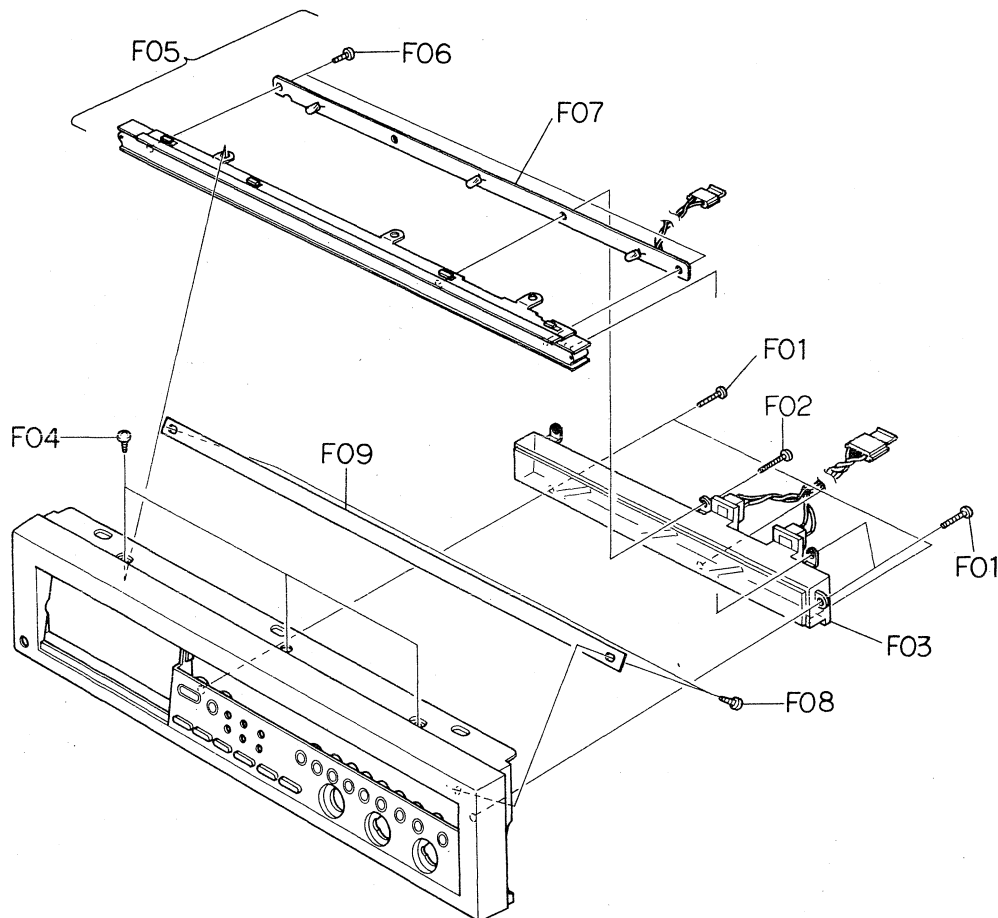

Fig. 3.4

3.18. Cover Plate Ass'y

Refer to Fig. 3.6.

- (1) Refer to Fig. 3.2. Remove Front Panel Ass'y referring to item 3.4.
- (2) Push the Eject Button to open the Cassette Case Ass'y.
- (3) Remove F05, then disassemble F06 (Cover Plate Ass'y).

3.19. Tape Counter Ass'y

Refer to Fig. 3.6.

- (1) Refer to Fig. 3.2. Remove Front Panel Ass'y referring to item 3.4.
- (2) Remove F07, then disassemble F08 (Tape Counter Ass'y).

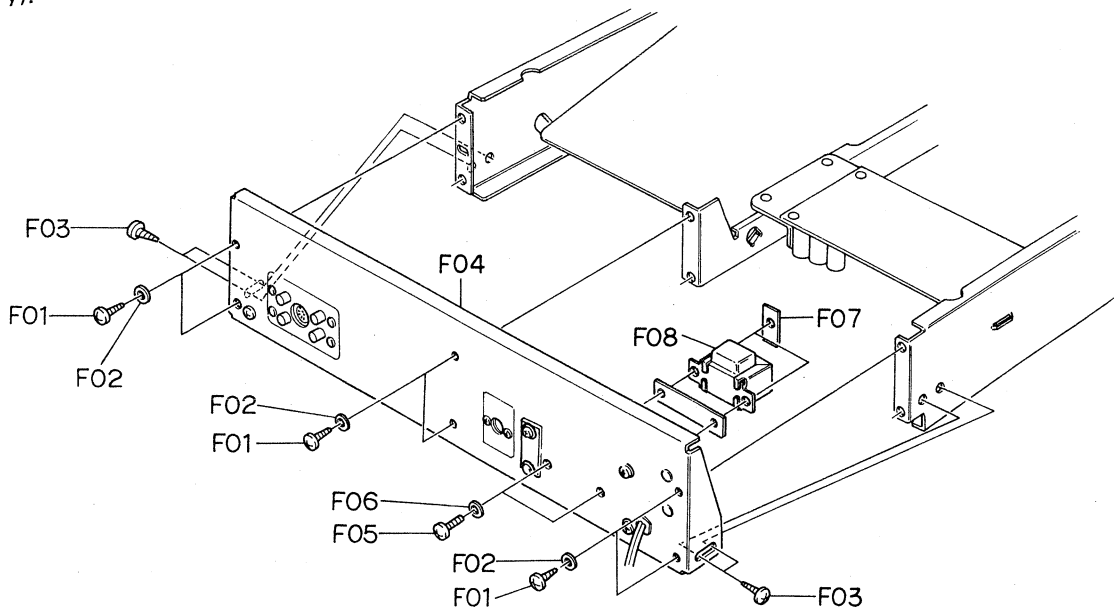

Fig. 3.5

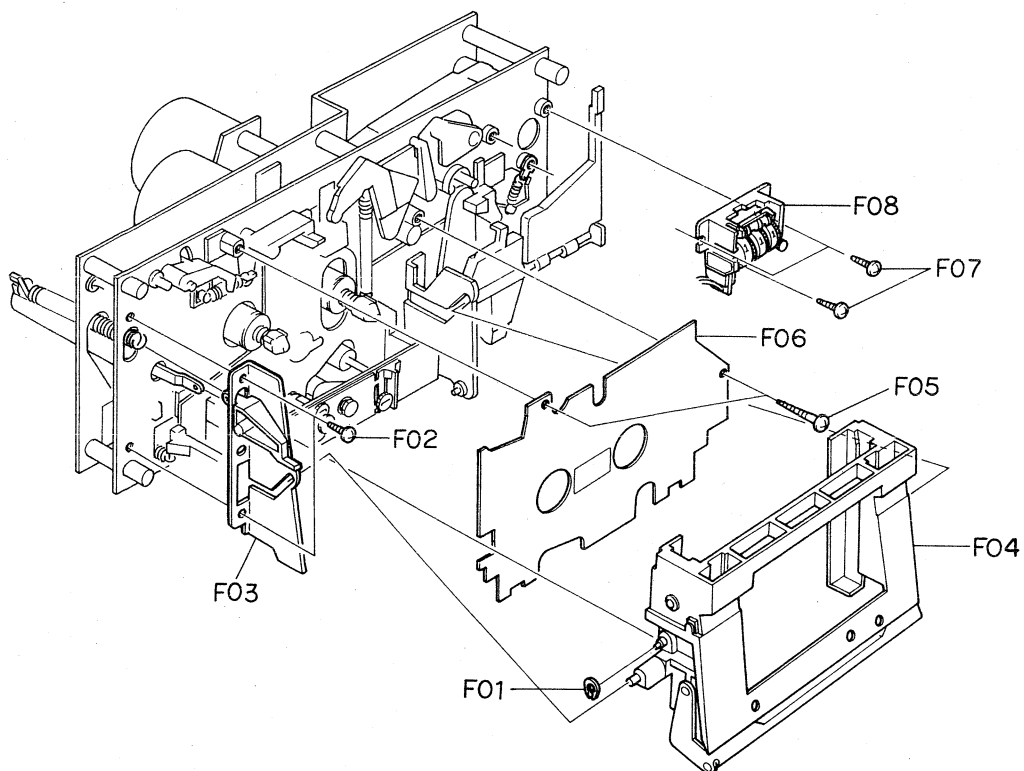

Fig. 3.6

3.20. Capstan Motor Ass'y and Flywheel Ass'y

Refer to Fig. 3.7.

- (1) Refer to Fig. 3.2. Remove Mechanism Ass'y referring to item 3.5.
- (2) Remove F01 and F02, then disassemble F03 (Flywheel Holder Ass'y).
- (3) Remove F04, then disassemble F05 (Capstan Motor Ass'y) and F06 (Capstan Belt).
- (4) Remove F07 (Supply Flywheel Ass'y), then disassemble F08 (Take-up Flywheel Ass'y).
- (5) After removing both Flywheel Assemblies, disassemble F09 (Thrust Washer 3.1 mm), F10 (Thrust Washer 2.6 mm), F11 (Flange Thrust Cap) and F12 (Flange Thrust Spring).

3.21. Sub Mechanism Chassis Ass'y

Refer to Fig. 3.8.

- (1) Refer to Fig. 3.2. Remove Mechanism Ass'y referring to item 3.5.
- (2) Remove Flywheel Holder Ass'y and both Flywheel Assemblies referring to above step 3.20.
- (3) Remove F01 and F02, then disassemble F03 (Sub Mechanism Chassis Ass'y).

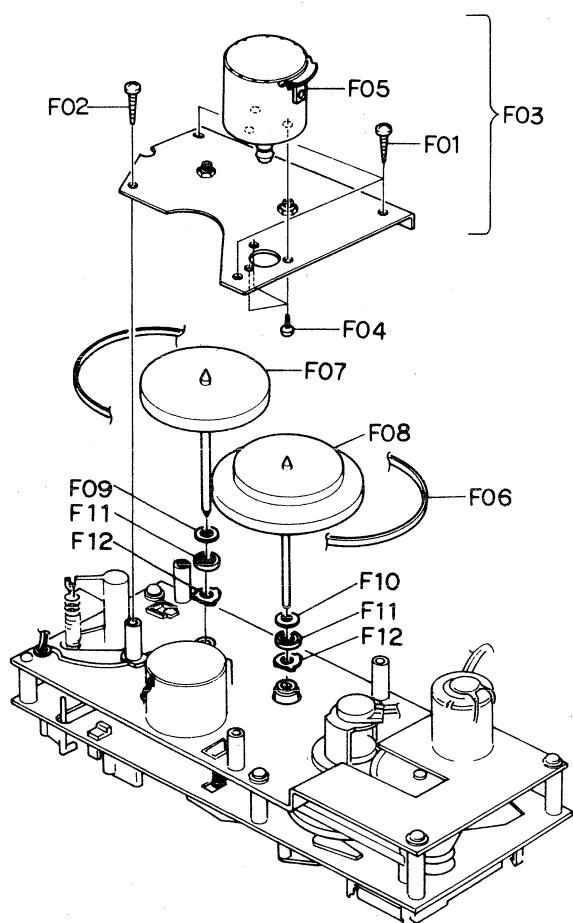

Fig. 3.7

3.22. Control Motor Ass'y

Refer to Fig. 3.8.

- (1) Remove Sub Mechanism Chassis Ass'y referring to item 3.21.
- (2) Remove F04, then disassemble F05 (Control Motor Ass'y).

3.23. Reel Motor Ass'y

Refer to Fig. 3.8.

- (1) Remove Sub Mechanism Chassis Ass'y referring to item 3.21.
- (2) Remove F06, then disassemble F07 (Reel Motor Ass'y).

3.24. Cam Control Volume

Refer to Fig. 3.8.

- (1) Remove Sub Mechanism Chassis Ass'y referring to item 3.21.
- (2) Remove F08, F09 (Volume Coupler) and F10, then disassemble F11 (Cam Control Volume).

3.25. Reel Hub Ass'y

Refer to Fig. 3.8.

- (1) Remove Sub Mechanism Chassis Ass'y referring to item 3.21.
- (2) Remove F12 (Reel Hub Head), then disassemble F13 (Reel Hub B Ass'y), F14 (Reel Hub Take-up Ass'y), F15 (Reel Hub Supply Ass'y), F16 (Back Tension Ass'y) and F17 (Back Tension Spring).

3.26. Idler Ass'y

Refer to Fig. 3.8.

- (1) Remove Sub Mechanism Chassis Ass'y referring to item 3.21.
- (2) Remove F18, then disassemble F19 (Idler Ass'y).

3.27. Cam Drive Gear and Control Cam

Refer to Fig. 3.8.

- (1) Remove Sub Mechanism Chassis Ass'y referring to item 3.21.
- (2) Remove F20, then disassemble F21 (Cam Drive Gear).
- (3) Remove F22, then disassemble F23 (Counter-Load Arm Ass'y).
- (4) Remove F24, then disassemble F25 (Control Cam).

3.28. Head Mount Base Ass'y

Refer to Fig. 3.9.

- (1) Refer to Fig. 3.6. Remove Cassette Case Ass'y referring to item 3.17.
- (2) Remove F01, then disassemble F02 (Head Mount Base Ass'y).

3.29. Supply Pressure Roller Ass'y

Refer to Fig. 3.9.

- (1) Remove Head Mount Base Ass'y referring to item 3.28.
- (2) Remove F03, then disassemble F04 (Supply Pressure Roller Ass'y).

3.30. Erase Head

Refer to Fig. 3.9.

- (1) Remove Head Mount Base Ass'y referring to item 3.28.
- (2) Remove F05, then disassemble F06 (Erase Head E-8L).

3.31. Take-up Pressure Roller Ass'y

Refer to Fig. 3.9.

- (1) Remove Head Mount Base Ass'y referring to item 3.28.
- (2) Remove F07, then disassemble F08 (Take-up Pressure Roller Ass'y).

3.32. Record/Playback Head Ass'y

Refer to Fig. 3.9.

- (1) Remove Head Mount Base Ass'y referring to item 3.28.
- (2) Turn F09 by 90° by pushing it, then disassemble F10 (Record/Playback Head RP-9E Ass'y).

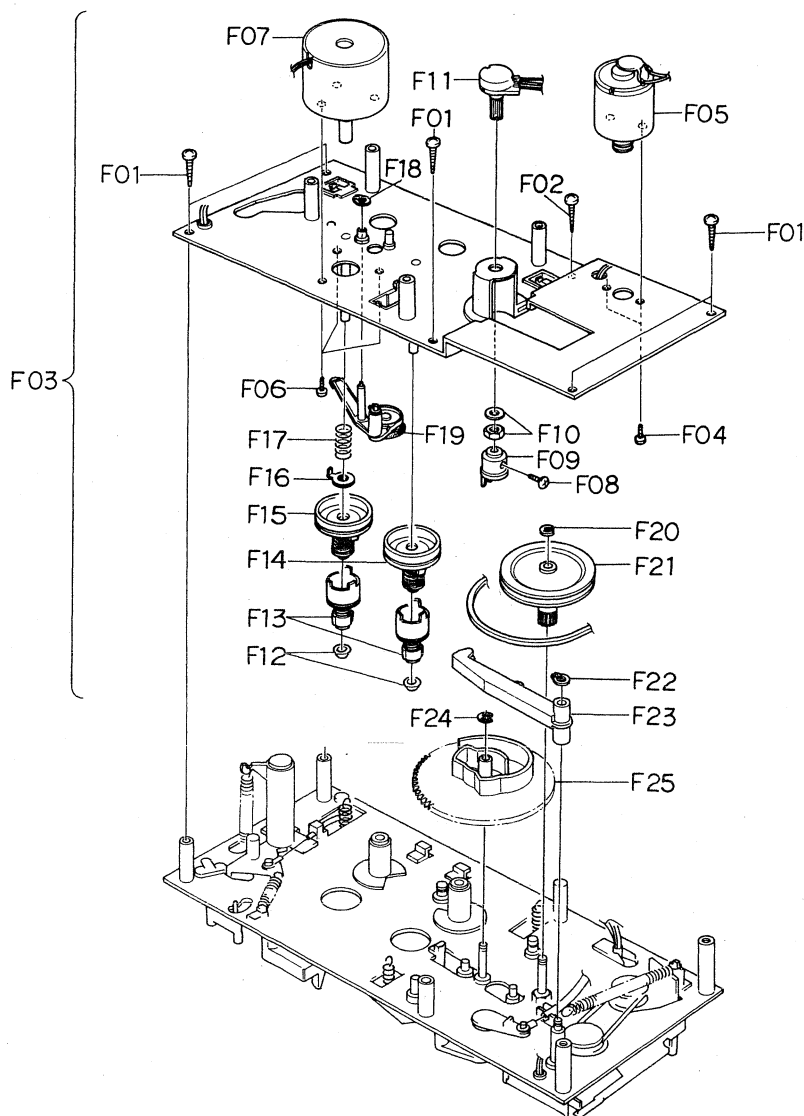

Fig. 3.8

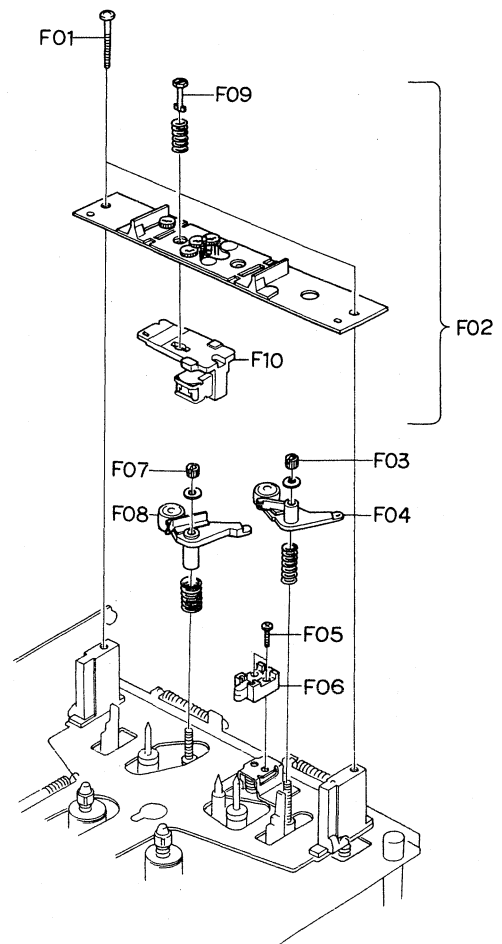

Fig. 3.9

4. MEASUREMENT INSTRUMENTS

- (1) Audio Generator (20 Hz – 200 kHz)
- (2) AC Millivolt Meter (with dB measures)
- (3) Oscilloscope (DC – 5 MHz)
- (4) Distortion Meter
- (5) Speed & Wow/Flutter Meter
- (6) Frequency Counter (DC – 1 MHz)
- (7) Ohm Meter
- (8) DC Volt Meter
- (9) AC Volt Meter
- (10) Torque Gauge (DA09013A)
- (11) 15 kHz Azimuth Tape (DA09004A)
- (12) 3 kHz Speed & Wow/Flutter Tape (DA09006A)
- (13) 1 kHz Track Alignment Tape (DA09007A)
- (14) 400 Hz Level Tape (DA09005A)
- (15) 20 kHz PB Frequency Response Tape (DA09001A)
- (16) 15 kHz PB Frequency Response Tape (DA09002A)
- (17) 10 kHz PB Frequency Response Tape (DA09003A)
- (18) Reference EXII Tape (DA09021A)
- (19) Reference SX Tape (DA09025A)
- (20) Reference ZX Tape (DA09037A)
- (21) Tilt Check Gauge M-9036 (DA09036A)
- (22) Stroke Check Gauge M-9038 (DA09038A)
- (23) EH Tilt Check Gauge M-9040 (DA09040A)
- (24) EH Stroke Check Gauge M-9042 (DA09042A)
- (25) Audio Analyzer T-100
(including Distortion, Wow/Flutter, Speed, Oscillator and dB meter)

Note: (10) – (25) are the products of Nakamichi Corporation.

5. MECHANICAL ADJUSTMENTS

5.1. Mechanism Control Cam Adjustment

Before adjustment, disassemble the Front Panel Ass'y then remove the Cover Plate, referring to items 3.4 and 3.18.

(1) Offset Adjustment of Control Motor Driver

(a) Refer to Figs. 5.1 and 5.2.

Adjust VR402 and VR401 on the Logic P.C.B. to locate approximately at the middle of the variable range. Then turn ON the Power Switch.

- VR402 (for Cam position stop)
- VR401 (for Cam position play)

(b) Press the Stop Switch to set the N-580M in stop mode. Adjust VR402 (for stop) so that the "S" mark on the Cam corresponds to the pointer on the mechanism chassis.

(c) Press the Play Switch to set the N-580M in playback mode.

(Cam will rotate, and the position marked with "PY" comes to the pointer.)

Adjust VR401 (for play) so that the "PY" mark on the Cam corresponds to the pointer.

(d) Repeat above (b) and (c) 2 - 3 times so that the "S" and "PY" marks on the cam correspond to pointer accurately in stop and playback modes respectively. (This adjustment is required because the position adjusted by one volume will be slightly changed when the other volume is adjusted.)

(e) Set the N-580M in FF, pause, record, or cue mode by pressing each switch (press FF and Pause Switches to set the N-580M in cue mode) and check to insure that the pointer is in a range of "F", "PS", "R", or "CU" mark respectively.

(f) If out of the range, precise adjustment for each position according to "(2) Offset Fine Adjustment of Control Motor Driver" will be required.

(2) Offset Fine Adjustment of Control Motor Driver

Adjust only if a satisfactory result is not obtained in "(1) Offset Adjustment of Control Motor Driver".

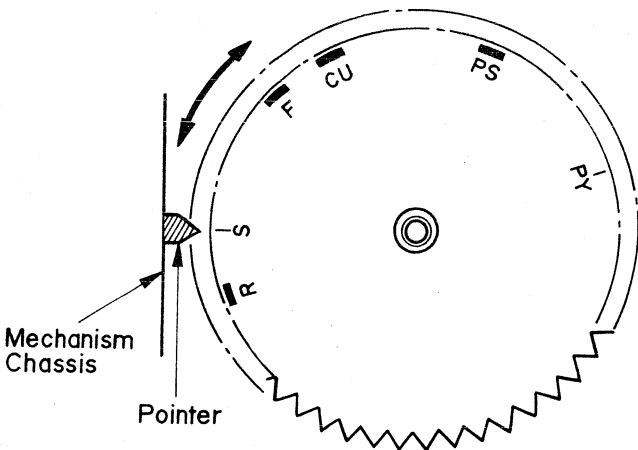

Fig. 5.1

This adjustment is made by changing the value of the fixed resistors on the Logic P.C.B. Voltages below shown are typical value.

(a) Observation Point of Reference Voltage

Observe the each voltage at the sliding contact of the Cam Control Volume VR601 (10 kΩ) in stop, fast (FF or REW), pause, record and playback modes.

Note: When Record and Play Switches are pressed to set N-580M in record mode, the Cam is first set to the record position in a short period of time then stays at the play position.

Therefore, to keep the Cam at the record position, following procedure is required:

Short the both leads of capacitor C426 (4.7 μF 25 V) on the Logic P.C.B. with a jumper wire, then press the Record and Play Switches.

(b) Reference Voltage

Reference voltage at the sliding contact of VR601 (Cam Control Volume) in each mode is as follows:

Mode	Reference Voltage (Typical Value)
Record	4.1 V
Stop	3.0 V
Fast (FF/REW)	1.3 V
Pause	-2.8 V
Play	-5.4 V

Additional voltage ranges shown in the diagram:

- Record: 1.1 V \pm 0.4 V
- Stop: 1.7 V \pm 0.25 V
- Pause: 2.6 V \pm 0.4 V

(c) Resistors for Adjustment

Mode	Ref. No.	Typical Value
Stop	R501	9.1 kΩ (F)
Fast (FF/REW)	R507	4.32 kΩ (F)
Pause	R514	287 kΩ (F)
Play	R511	174 kΩ (F)
Record	R499	27 kΩ

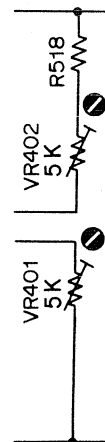

Fig. 5.2

(d) Adjustment Procedures

- 1) Press the Stop Switch to set the N-580M in stop mode. Adjust the value of R501 to obtain 3.0 V (± 0.6 V) at the sliding contact of VR601.

Note: When R501 is adjusted, the reference voltage in fast (FF or REW) mode is changed. Therefore, re-check of the reference voltage in fast (FF or REW) mode is required.

If the reference voltage is out of the range, re-adjustment of R507 according to next step 2) is necessary.

- 2) Set the N-580M in FF mode, then adjust the value of R507 so that the voltage of VR601 will become lower by 1.7 V (± 0.25 V) than in stop mode.
- 3) Press the Pause Switch to set the N-580M in pause mode. Adjust the value of R514 to obtain -2.8 V ($+0.4$, -0.15 V) at the sliding contact of VR601.
- 4) Set the N-580M in playback mode, then adjust the value of R511 so that the voltage of VR601 will become lower by 2.6 V (± 0.4 V) than in pause mode.
- 5) Short the both leads of capacitor C426 with a jumper wire.

Set the N-580M in record mode, then adjust the value of R499 so that the voltage of VR601 will become higher by 1.1 V ($+0.4$, -0.2 V) than in stop mode.

Note: Remove the short of C426 after completion of adjustment.

(3) Cam Timing Adjustment

- (a) Remove the wires from the Control Motor Terminals to set the motor open.
- (b) Without loading a cassette tape and with pressing the Record Protecting Switch with your fingers, press the Record and Play Switches to set the N-580M in record mode.
- (c) Turn the Cam and bring the "PY" mark toward the pointer by hand. Reel Motor will rotate before the "PY" mark reaches the pointer. Adjust the value of R488 so that the voltage at sliding contact of VR601 becomes -3.6 V (± 0.3 V) when Reel Motor starts rotation.
- (d) Observe the mute signal at the Q424 collector. Turn the Cam referring to above step (c) and check to insure that the voltage at the sliding contact of VR601 is -3.8 V (± 0.3 V) when mute is released (mute signal changes from H to L). (This voltage is determined by the adjustment of R488 in above step (c).)
- (e) Observe the $\overline{\text{Rec}}$ signal at the Q421 collector. Turn the Cam referring to above step (c) and adjust the value of R480 to obtain -2.1 V (± 0.4 V) at the sliding contact of VR601 when $\overline{\text{Rec}}$ signal changes from H to L (bias oscillation will begin).

- (f) Upon completion of above adjustment, re-connect wires to the motor terminals.

5.2. Tape Speed Adjustment

- (1) Remove the Top Cover.
- (2) Connect a Frequency Counter to the Output Jack.
- (3) Load a 3 kHz Speed Wow/Flutter Tape (DA09006A) and play it back.
- (4) Referring to Fig. 5.3, adjust the Tape Speed Adjustment Volume (VR501) incorporated in the Capstan Motor to obtain 3,000 Hz on the Frequency counter.

CCW: Motor drives slowly.

CW: Motor drives fast.

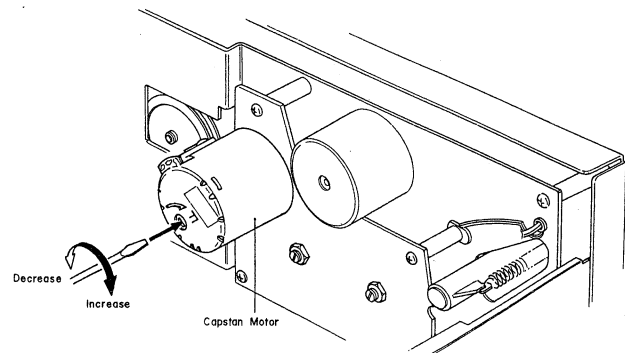

Fig. 5.3

5.3. Record/Playback Head Tilt Adjustment

Note: On items 5.3 – 5.7, please refer to Fig. 5.4 adjustment flow chart.

Refer to Figs. 5.5 and 5.6.

- (1) Load a Tilt Check Gauge M-9036 (DA09036A) in the N-580M.
- (2) Clip the grounding terminal of the Tilt Check Gauge with one end of the cord with clip, and the other end to the chassis of the N-580M.
- (3) Remove Height Gear.
- (4) Set the N-580M in play mode. Check to insure whether the Beacon "Upper" or "Lower" is illuminating. In order not to give damages onto the record/playback head surface, push the slide knob of the Gauge to the direction of an arrow mark, then return it to the original place to be in contact with record/playback head surface after play mode is securely locked.
- (5) Check to insure freedom from contact between the Gauge and pad lifter.
- (6) Beacon "Lower" will light on when height adjustment screw turned clockwise but "Upper" when counterclockwise. Adjust so that both "Upper" and "Lower" will light on even when you move the slide knob to the direction of an arrow mark and then return it to the original place.
- (7) Set the N-580M in stop mode and fit the serrated Height Gear. Then set the N-580M again in play mode and insure 2 Beacons "Upper" and "Lower" are illuminating. If not, (3) through (6) will have to be repeated till satisfactory results are obtained.

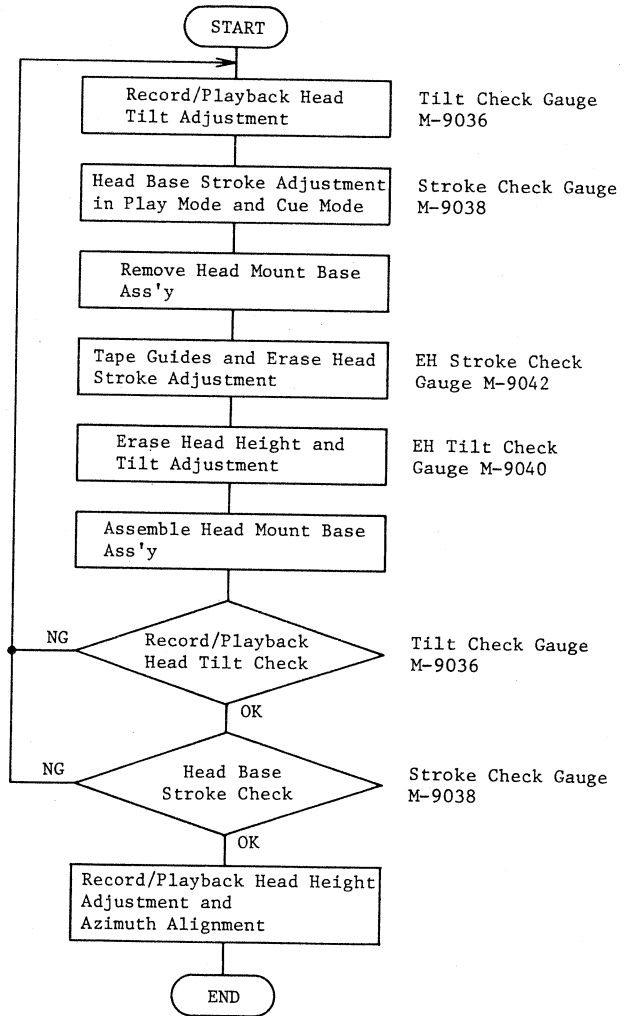

Fig. 5.4 Flow Chart

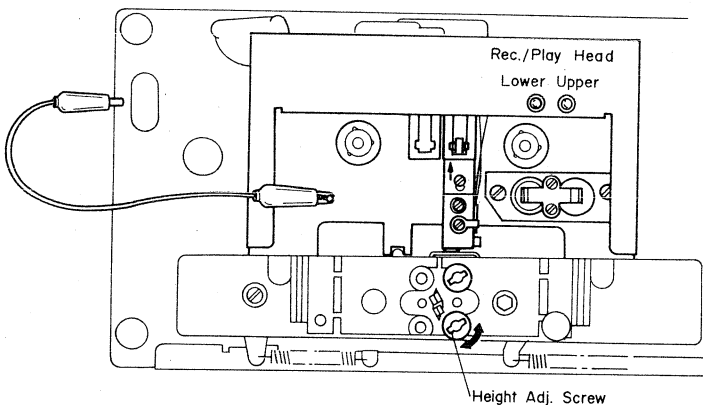

Fig. 5.5

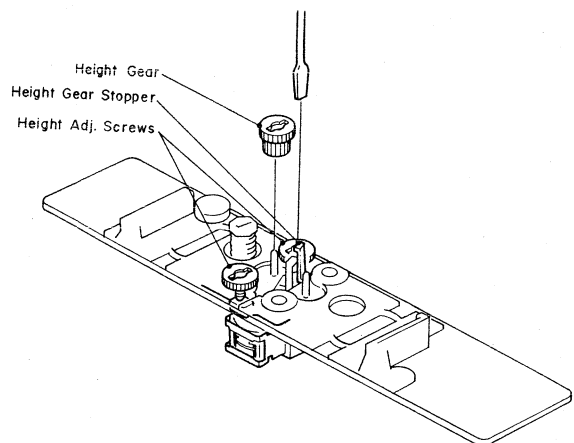

Fig. 5.6

5.4. Head Base Stroke Adjustment in Play and Cue Modes

Note: Before you conduct "Head Base Stroke Adjustment in Play and Cue Modes", adjust with a "Tilt Check Gauge" to insure freedom from tilt on the record/playback head.

(1) Head Base Stroke Adjustment in Play Mode

Refer to Fig. 5.7.

- Load a Stroke Check Gauge M-9038 (DA09038A) in the N-580M.
- Set the N-580M in play mode.
- Check to insure whether the "P" pointer on the Stroke Indicator locates between the 2 lines as marked on the Stroke Check Plate.
- If the playback head stroke is noted to be misaligned, adjustment can be made by moving the stroke adjuster assembled in the head base assembly (either forwardly or backwardly).

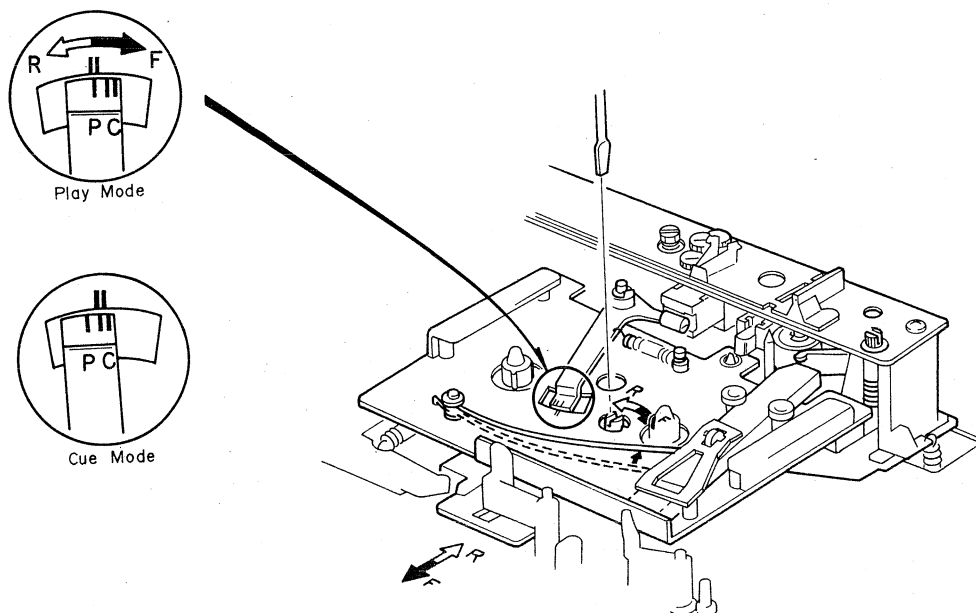

Fig. 5.7

(2) Head Base Stroke Adjustment in Cue Mode

Refer to Fig. 5.8.

- Load a Stroke Check Gauge M-9038 (DA09038A) in the N-580M.
- Set the N-580M in cue mode (FF and Pause).
- Check to insure whether the "C" pointer on the Stroke Indicator locates between the 2 lines as marked on the Stroke Check Plate.
- If the playback head stroke is noted to be misaligned, adjust VR403 of the Logic P.C.B. Ass'y till satisfactory results are obtained.
- After completion of the Head Base Stroke Adjustment, check to insure accuracy of the Head Base Adjustment in play mode.

If the above are inaccurate, items (1) and (2) will have to be repeated till satisfactory results are obtained.

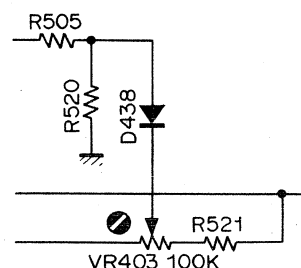

Fig. 5.8

5.5. Tape Guides Adjustment and Erase Head Stroke Adjustment

Remove Head Mount Base Ass'y referring to item 3.28. Refer to Figs. 5.9 and 5.10.

(1) Supply Tape Guide Height Adjustment

- Load an EH Stroke Check Gauge M-9042 (DA09042A) in the N-580M.
- Set the N-580M in play mode.
- Slide the Supply Tape Guide Check Bar down against the supply tape guide, thus check can be made on supply tape guide height.
- If the supply tape guide is misaligned, the Supply Tape Guide Check Bar will not come into the supply tape guide. If such is noted, turn to adjust the height adjustment nut A till the Supply Tape Guide Check Bar is accepted by the supply tape guide.
- If the above are insured, set the N-580M in pause mode, then in play mode to see whether adjustments are appropriately made. If not, (b) through (e) will have to be repeated till satisfactory results are obtained.

(2) Take-up Tape Guide Height Adjustment

- Load an EH Stroke Check Gauge M-9042 (DA09042A) in the N-580M.

- Set the N-580M in play mode.
- Slide the Take-up Tape Guide Check Bar down against the take-up tape guide, thus check can be made on take-up tape guide height.
- If the take-up tape guide is misaligned, the Take-up Tape Guide Check Bar will not come into the take-up tape guide. If such is noted, turn to adjust the height adjustment nut B till the Take-up Tape Guide Check Bar is accepted by the take-up tape guide.
- If the above are insured, set the N-580M in pause mode, then in play mode to see whether adjustments are appropriately made. If not, (b) through (e) will have to be repeated till satisfactory results are obtained.

(3) Erase Head Stroke Adjustment

- Load an EH Stroke Check Gauge M-9042 (DA09042A) in the N-580M.
- Set the N-580M in play mode, thus check can be made on erase head stroke through the EH Stroke Indicator.
- Check to insure whether the erase head surface is aligned with red line on the EH Stroke Indicator. If not, adjust the erase head stroke by loosening 2 screws that assembled erase head and erase head plate.
- After completion of adjustment, 2 pcs. of screws shall be locked with lock tight paint.

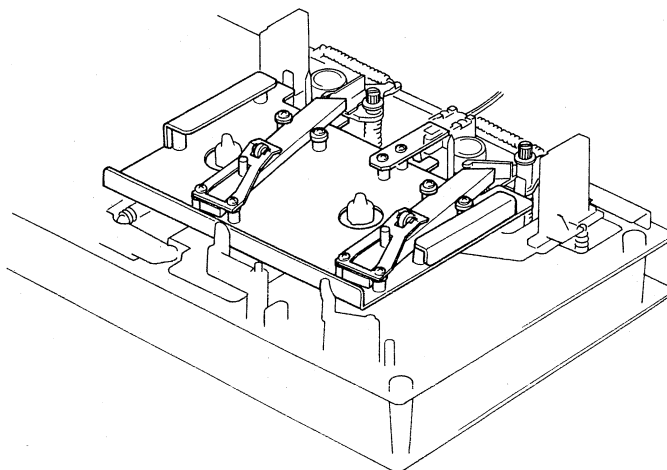

Fig. 5.9

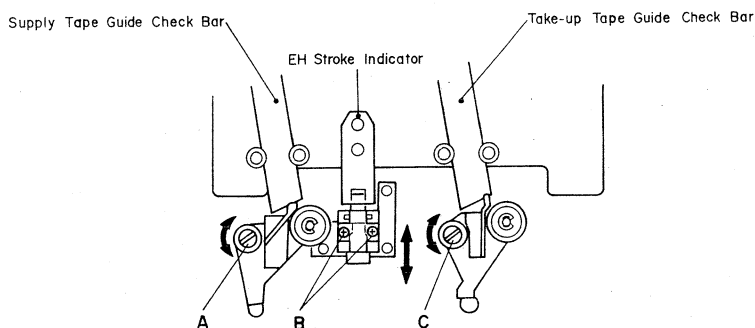

Fig. 5.10

5.6. Erase Head Height and Tilt Adjustment

Refer to Figs. 5.11 and 5.12.

- (1) Remove Head Mount Base Ass'y, referring to item 3.28.
- (2) Load an EH Tilt Check Gauge M-9040 (DA09040A) in the N-580M.
- (3) Set the N-580M in stop mode.
- (4) Check to insure whether one of the 3 Beacons is illuminating. Look down the mirror as shown by an arrow mark and slowly turn the Screw "Height" counterclockwise (or clockwise) so that the two horizontal lines of the mirror will become superposed on the line (in different color) of the erase head, and check to insure whether Beacon "1" is illuminating.
- (5) Turn Screw "Tilt" counterclockwise (or clockwise) to light on Beacon "2". Excessive turning will cause the Beacon "1" to light off. Adjustments of Screw "Tilt" will therefore be conducted till both of the Beacons "1" and "2" illuminate.
- (6) Turn Screw "Azimuth" counterclockwise (or clockwise) to light on Beacon "3". Excessive turning will cause either Beacon "1" or "2" to light off, and therefore adjust with Screw "Azimuth" until all of the 3 Beacons, "1", "2" and "3" illuminate.
- (7) Check to insure whether the horizontal line on the mirror corresponds to that on the erase head. If not, (4) through (7) will have to be repeated till satisfactory results are obtained.
- (8) After completion of adjustment, 3 pcs. of screws shall be locked with lock tight paint.

Note: Before use of this gauge, check to insure freedom from dust or dirt, or overflow in the groove of the erase head surface.

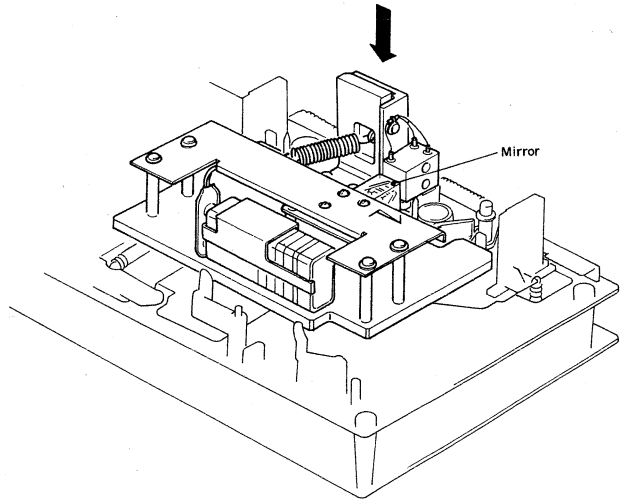

Fig. 5.11

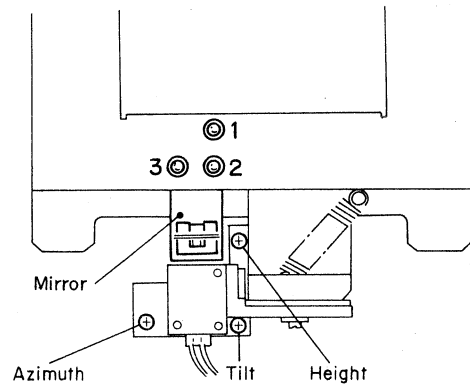

Fig. 5.12

5.7. Record/Playback Head Height Adjustment and Azimuth Alignment

Refer to Fig. 5.13.

- (1) Connect a VTVM to the output jacks.
- (2) Load a 1 kHz Track Alignment Tape (DA09007A) in the N-580M.
- (3) Set the N-580M in play mode.

- (4) Turn the Height Gear until the output of the both channels becomes minimum.
- (5) Load a 15 kHz Azimuth Tape (DA09004A) in the N-580M.
- (6) Set the N-580M in play mode.
- (7) Turn the Azimuth Alignment Screw until the output of the both channels becomes maximum.
- (8) Repeat (2) through (7) for 1 - 2 times.

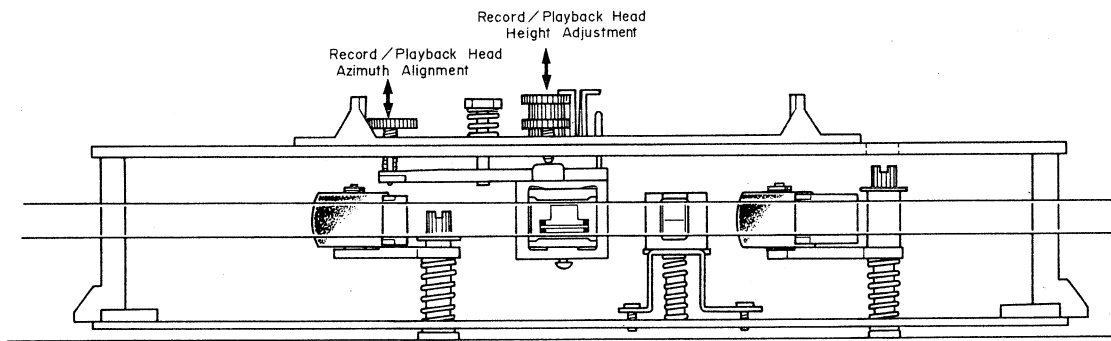

Fig. 5.13

5.8. Tape Travelling Adjustment

The adjustment shall be made with a modified version of the current type EXII C-90 tape as shown in Fig. 5.14 (error will be made if a current type Tape Travelling Cassette (DA09011A) should be used for this purpose). While modifying an EXII C-90 tape, the tape guides in the cassette housing shall be kept protected to avoid tilt. Check shall be made in the following procedures:

- (1) An EXII C-90 tape thus modified shall be loaded onto the N-580M.
- (2) Release the back-tension (rotate the supply reel and feed out some length of tape) and set the N-580M in play mode.
- (3) In this juncture, check to insure whether the tape is freedom from waving or slippage from the both of tape guides.
- (4) When the modified EXII C-90 tape is played back, check to insure whether the tape is freedom from waving from head surface or at pressure rollers.
- (5) If either of waving or slippage from the tape guides should be noted, re-adjustment of "5.3. Record/Playback Head Tilt Adjustment", "5.4. Head Base Stroke Adjustment in Play and Cue Modes", "5.5. Tape Guides Adjustment and Erase Head Stroke Adjustment", "5.6. Erase Head Height and Tilt Adjustment", "5.7. Record/Playback Head Height Adjustment and Azimuth Alignment", etc. will be required.

As a case may be, the said waving or slippage may have been caused from defective Supply Pressure Roller Ass'y or Take-up Pressure Roller Ass'y without parallel contact with capstans.

If such are noted, the Pressure Roller Assemblies will have to be replaced. Further, excessively weak take-up torque or strong take-up torque may cause defective tape travelling.

The N-580M is intended to be adjustment-free Model. However if the similar matters as above should be noted, please replace the Reel Hub Take-up Ass'y to obtain appropriate take-up torque.

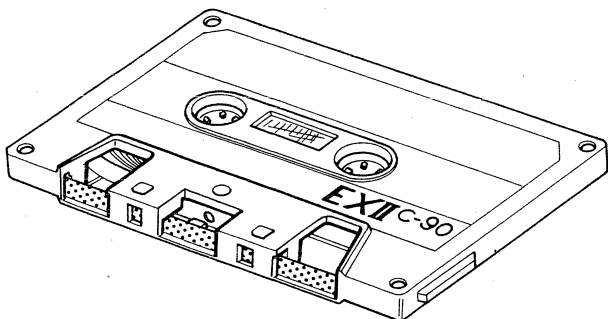

Fig. 5.14

5.9. Record Switch Linkage Adjustment

- (1) Set the N-580M in stop mode.
- (2) Loosen the screw of the Record Spring Holder, and shift the Record Spring Holder in order to remove the looseness of the Linkage Wire as shown in Fig. 5.15.1. Then tighten the screws for fixing the Record Spring Holder. (In this case, the Record Switch should be positioned at play side. If on the record position, it will be defective.)
- (3) Set the N-580M in record and pause mode. Check to insure that the gap between the top of the wire and the Record Spring Holder is approx. 1 mm as shown in Fig. 5.15.2. (Check that the Record Switch is in record position.)
- (4) Upon completion of the above adjustments, apply a quantity of lock tight paint.

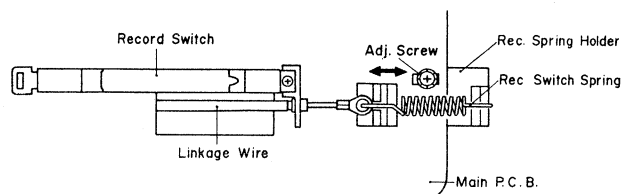

Fig. 5.15.1

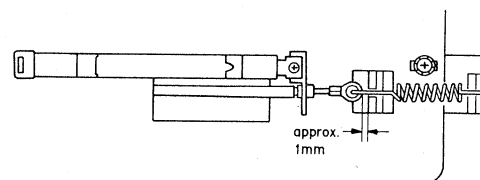

Fig. 5.15.2

5.10. Flywheel Holder Adjustment

- (1) Refer to Fig. 5.16. Tighten the Thrust Screws until the gap between the Flywheel Assemblies and Thrust Screws becomes minimized when both of the Capstan Shafts are moved backwardly and forwardly (the Thrust Springs between the Capstan Flanges and Flywheel Thrust Caps are in a flat state). Excessive tightening of the Thrust Screws however will give damages on the Flywheel Assemblies, to which careful attention is invited.
- (2) Return the Thrust Screws by 1/2 turn.
- (3) Fixing the Thrust Screws with a screwdriver, lock the Lock Nut.
- (4) Apply a quantity of lock tight paint to the Thrust Screws.

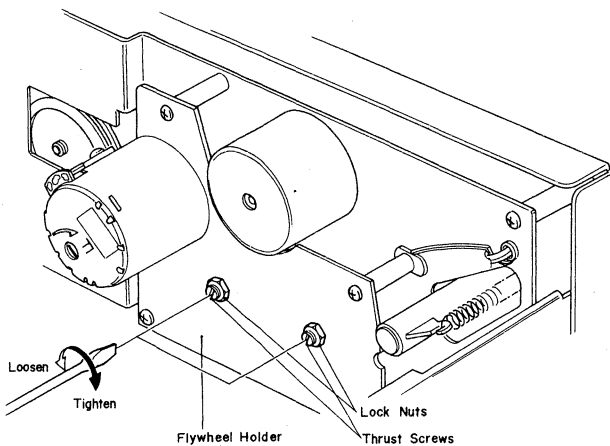

Fig. 5.16

5.11. Eject Wire Adjustment

- (1) Referring to Fig. 5.17.1, insert a 1.5 mm spacer between the Eject Arm and Eject Stopper by turning the Eject Arm in the illustrated direction, then set the N-580M in playback mode.
- (2) With pushing the Eject Arm by hand, loosen the screw and then pull the Eject Wire in the direction of the arrow until it stops as shown in Fig. 5.17.2.
- (3) Tighten the screw, then apply a quantity of lock tight paint.

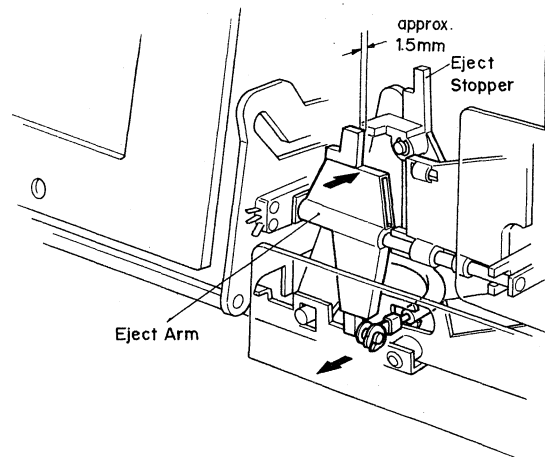

Fig. 5.17.1

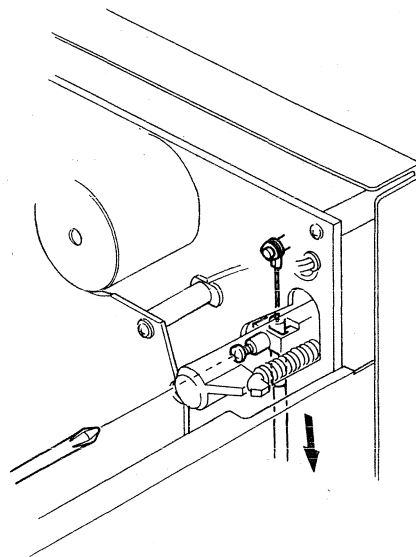

Fig. 5.17.2

5.12. Control Button Stroke Adjustment

Normal state of push button stroke for Logic Control on the Front Panel is as follows:

- (1) When Front Panel is in place, push the Control Button with a finger tip and see if it has an allowance of 0.6 mm. If it does, then push it a little further for another 0.4 mm and see if the switch is ON.

This allowance can be adjusted by loosening the screws that assembled Control Button Holder and Front Chassis together. After the adjustment, lock the screws with lock tight paint.

- (2) When performing adjustment, put the Front Panel aside, but for checking, do it with the Panel on.

5.13. Lubrication

N-580M is a lubrication-free cassette deck except when parts are replaced. Apply the following lubricant for each replaced part:

- (1) LAUNA #100

Capstan Shaft
Pressure Roller Shaft
Thrust Cap

- (2) FLOIL GB-TS-1

Reel Hub Shaft
Thrust portion on the Capstan Shaft
FLOIL GB-TS-1, made by Kanto Chemicals Co., Ltd., in Japan.

We suggest you use the above or equivalent type. If unavailable please contact Kanto Chemicals Co., Ltd., 2-7 Kanda Suda-cho Chiyoda-ku, Tokyo 101 Japan.

- (3) Silicon Oil #3000CST

Air Damper Piston

Note: Excessive lubrication may cause defective damper action as the 0.2 ϕ hole at the end of the cylinder may be filled with oil.

6. PARTS LOCATION FOR ELECTRICAL ADJUSTMENT

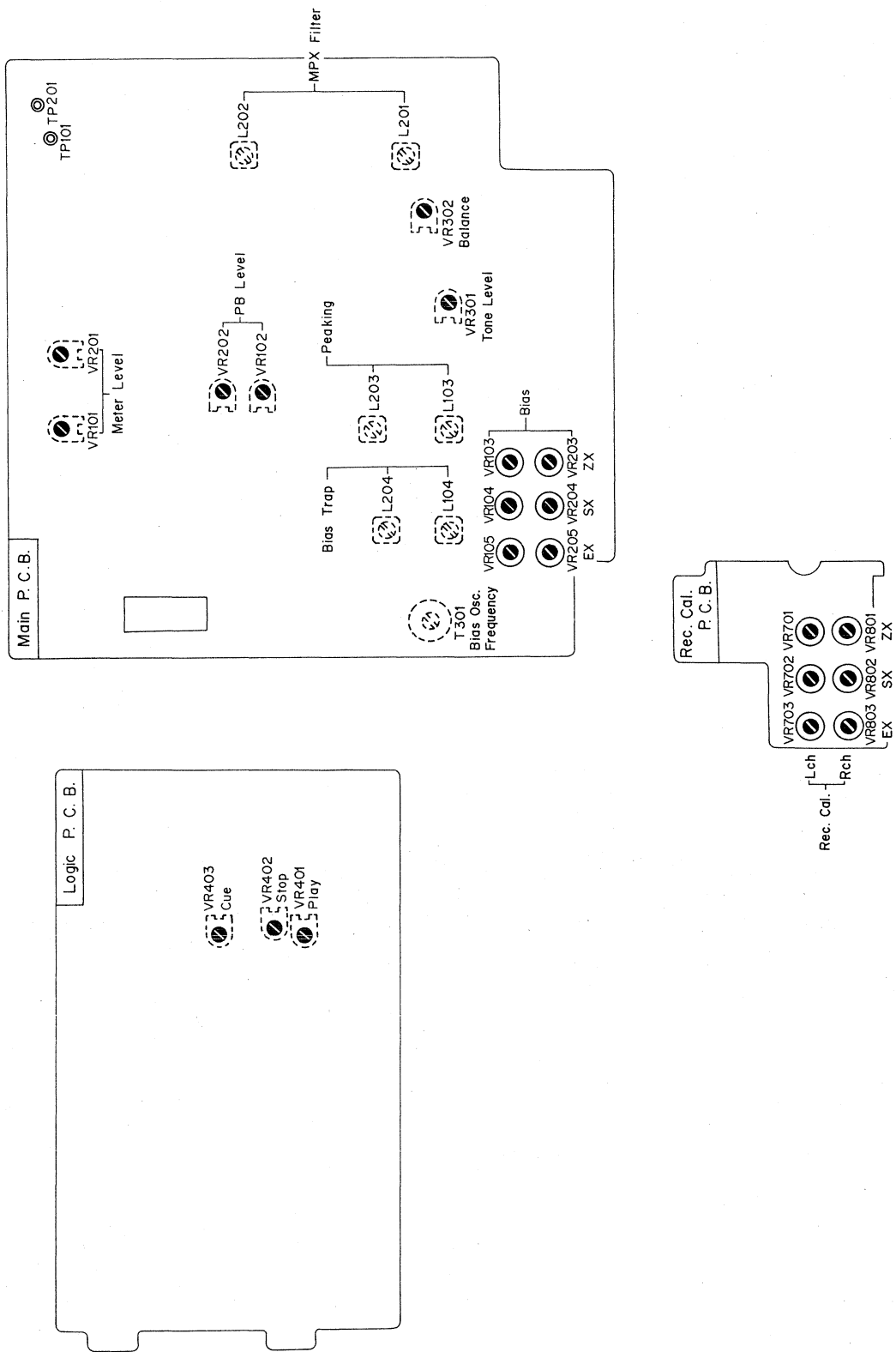

Fig. 6

7. ELECTRICAL ADJUSTMENTS AND MEASUREMENTS

7.1. Adjustment and Measurement Instructions

Note: Electrical adjustment should be performed after mechanical adjustment is completed.

STEP	ITEM	SIGNAL SOURCE	OUTPUT CONNECTION	MODE	ADJUSTMENT	REMARKS
1	Tape Speed	3 kHz Speed and Wow/Flutter Tape (DA09006A)	Frequency Counter to OUTPUT Jacks	Playback Eq. SW – 70 μ s	Capstan Motor Governor P.C.B. VR501	Adjust VR501 to obtain 3 kHz \pm 0.5%. (VR501 is incorporated in the Motor.)
2	Tone Calibration	Test Tone 400 Hz	VTVM to TP101, TP201 on the Main P.C.B.	Record, Pause Tone SW – ON	Main P.C.B. VR301 VR302	1. Set the Tone Switch to ON. Turn output level control fully clockwise (maximum position). 2. Adjust VR301 to obtain 100 mV \pm 0.2 dB at TP201 on the VTVM. Output will be 1 V (0 dB). 3. Adjust VR302 to obtain the same level as right channel at TP101 on the VTVM.
3	Meter Level	400 Hz Test Tone or 400 Hz to INPUT Jacks	Same as above	Same as above or Record, Pause Tone SW – OFF	Main P.C.B. VR101, VR201	1. Adjust VR101 (VR201) to obtain 0 dB on the level meters at 100 mV level on the VTVM. 2. Decrease input level by 10 dB/20 dB then short or open R120 (R220) and R121 (R221) to obtain minimum deviation from -10 dB/-20 dB on the level meters. (Perform at -10 dB and -20 dB.) 3. Again increase input level so that output will become 100 mV, then re-adjust VR101 (VR201) to obtain 0 dB on the level meters.
4	MPX Filter	19 kHz \pm 100 Hz to INPUT Jacks	VTVM to OUTPUT Jacks	Record, Pause Tone SW – OFF MPX SW – OUT/IN	Main P.C.B. L102, L202	1. Turn output level control fully clockwise (maximum position). 2. Adjust input level controls to obtain 1 V on the VTVM. 3. Set the MPX Switch to IN position, then adjust L101 (L201) to obtain minimum reading on the VTVM (minimum reading will be less than -30 dB).
5	Record/Playback Head Track Alignment	1 kHz Track Alignment Tape (DA09007A)	Same as above	Playback Tone SW – OFF MPX SW – OUT Eq. SW – 70 μ s Dolby NR SW – OUT	Record/Playback Head Height Adj. Screw	Adjust the Record/Playback Head Height Adj. Screw to obtain minimum reading of both L and R channels on the VTVM. See "Record/Playback Head Height Adjustment and Azimuth Alignment" in item 5.7.
6	Record/Playback Head Azimuth Alignment	15 kHz Azimuth Tape (DA09004A)	Same as above	Same as above	Record/Playback Head Azimuth Alignment Screw	Adjust the Record/Playback Head Azimuth Alignment Screw to obtain maximum reading of both L and R channels on the VTVM. See "Record/Playback Head Height and Azimuth Alignment" in item 5.7. Note: Repeat steps 5 and 6 one or two times to obtain optimum performance.
7	Playback Level	400 Hz Level Tape (DA09005A)	VTVM to TP101, TP201	Same as above	Main P.C.B. VR102, VR202	Adjust VR102 (VR202) to obtain 100 mV on the VTVM or 0 dB on the level meters.

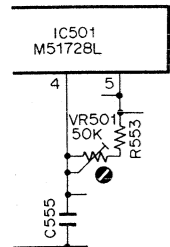

Fig. 7.1
1. Tape Speed

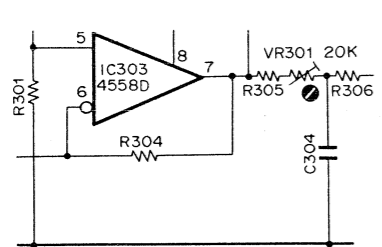

Fig. 7.2
2. Tone Calibration

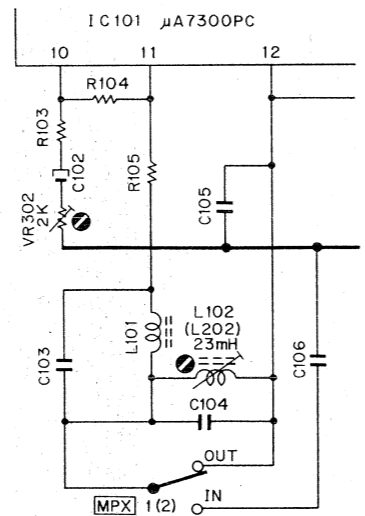

Fig. 7.3
2. Tone Calibration
4. MPX Filter

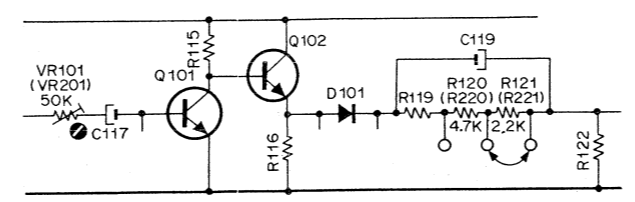

Fig. 7.4
3. Meter Level

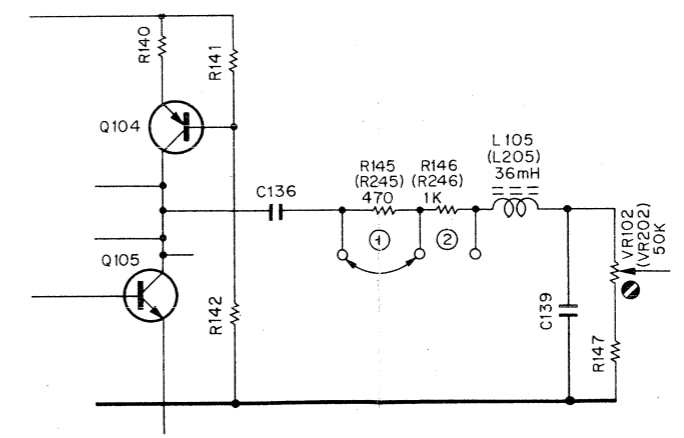

Fig. 7.5
7. Playback Level

STEP	ITEM	SIGNAL SOURCE	OUTPUT CONNECTION	MODE	ADJUSTMENT	REMARKS
8	Playback Frequency Response	400 Hz Level Tape (DA09005A) 10 kHz PB Frequency Tape (DA09003A) 15 kHz PB Frequency Tape (DA09002A) 20 kHz PB Frequency Tape (DA09001A)	VTVM to OUTPUT Jacks	Playback Eq. SW — 70 μ s Dolby NR SW — IN MPX SW — OUT	Main P.C.B. R145, R245 R146, R246	<ol style="list-style-type: none"> 1. Load the 400 Hz level tape and play it back. Adjust the output level control to a certain level (example 0 dB). 2. Load the 10 kHz, 15 kHz and 20 kHz PB frequency response tapes and adjust the record/playback head azimuth to give maximum levels on the VTVM with each tape. Short R145 (R245) and/or R146 (R246) to obtain the following levels against 400 Hz level tape. Refer to Fig. 7.5. 10 kHz: -20 dB -1 dB to +2 dB 15 kHz: -20 dB -1 dB to +3 dB 20 kHz: -20 dB -1 dB to +4 dB 3. Conduct step 6 "Record/Playback Head Azimuth Alignment". 4. If above is not sufficient, refer to "Playback Frequency Response Adjustment" in item 7.2.
9	Bias Oscillation Frequency and Erase Current	External 0.1 Ω Resistor in series to Erase Head	VTVM and Frequency Counter across the 0.1 Ω Resistor	Record, Pause ZX SW — IN Eq. SW — 70 μ s Dolby NR SW — OUT MPX SW — OFF	Main P.C.B. T301 R317, R328	<ol style="list-style-type: none"> 1. Adjust T301 to obtain 105 kHz on the frequency counter. 2. Check the erase current by the VTVM. Erase current will be in a range of 310 mA to 400 mA (typically approx. 350 mA). If erase current is not sufficient, increase it by shorting R317 or R328. 3. After completion of the erase current adjustment, re-check the bias oscillation frequency.
10	Record Amplifier Equalizer	23 kHz (-20 dB) to INPUT Jacks	VTVM to CN1-3, CN1-5 on the Main P.C.B.	Same as above	Main P.C.B. L103, L203	<ol style="list-style-type: none"> 1. Remove the bias-cut-jumper from the dip side of the Main P.C.B. 2. Adjust L103 (L203) to obtain peak reading at 23 kHz on the VTVM. 3. Re-solder the bias-cut-jumper.
11	Bias Trap	Remove INPUT Signals	Same as above	Same as above	Main P.C.B. L104, L204	Adjust L104 (L204) to obtain maximum reading on the VTVM.
12	Record Level Calibration	400 Hz Test Tone or 400 Hz to INPUT Jacks	VTVM to OUTPUT Jacks	Record and Playback ZX SW — IN/OUT SX/EX SW — SX/EX Eq. SW — 120 μ s (EX) 70 μ s (SX/ZX) Dolby NR SW — OUT MPX SW — OUT Tone SW — ON	Rec. Cal. P.C.B. VR701, VR801 VR702, VR802 VR703, VR803	<ol style="list-style-type: none"> 1. Record signals on the reference EXII (DA09021A), reference SX (DA09025A), or reference ZX (DA09037A) then play it back. 2. Repeating 1 as above, adjust VR703 (VR803) (for EXII), VR702 (VR802) (for SX) and VR701 (VR801) (for ZX) to obtain 0 dB on the level meters in playback mode.

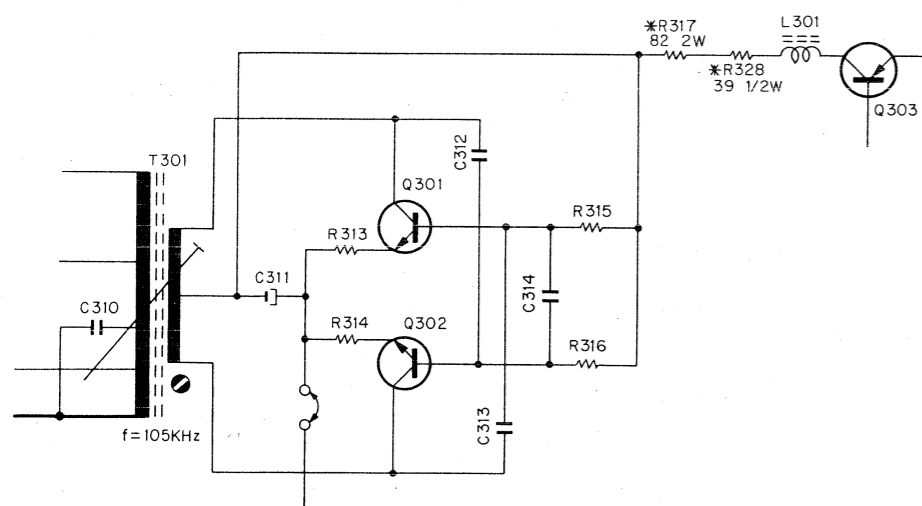

Fig. 7.6
9. Bias Oscillation Frequency

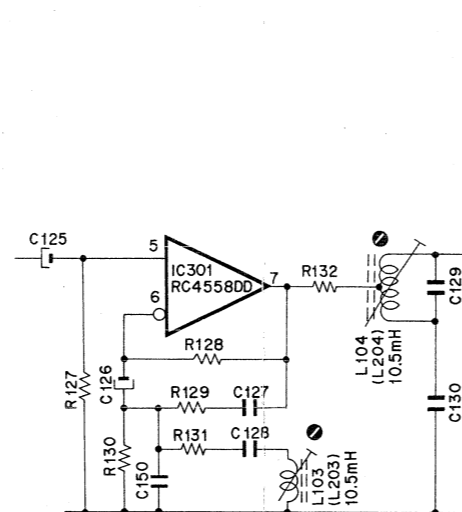

Fig. 7.7
10. Record Amplifier Equalizer
11. Bias Trap

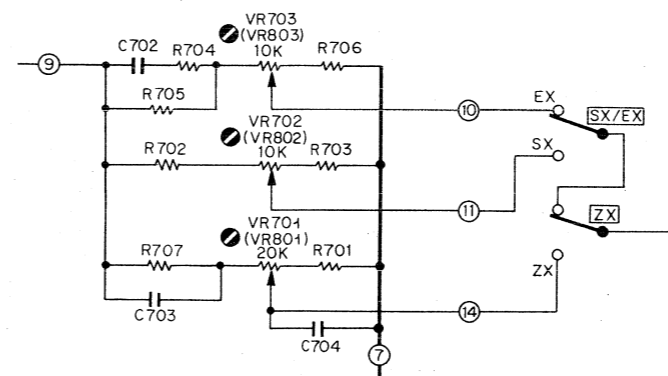

Fig. 7.8
12. Record Level Calibration

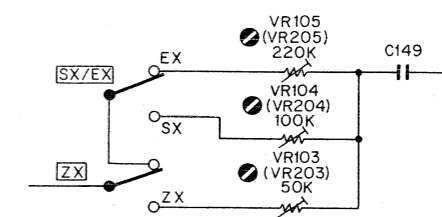

Fig. 7.9
13. Recording Bias Current and Overall Frequency Response

STEP	ITEM	SIGNAL SOURCE	OUTPUT CONNECTION	MODE	ADJUSTMENT	REMARKS
13	Recording Bias Current and Overall Frequency Response	400 Hz Test Tone or 400 Hz to INPUT Jacks and 20 Hz to 20 kHz (-20 dB) to INPUT Jacks	VTVM and Distortion Meter to OUTPUT Jacks	Record and Playback ZX SW - IN/OUT SX/EX SW - SX/EX Eq. SW - 120 μ s (EX) 70 μ s (SX, ZX) Dolby NR SW - OUT MPX SW - OUT Tone SW - ON/OFF	Main P.C.B. VR103, VR203 VR104, VR204 VR105, VR205	<ol style="list-style-type: none"> 1. Feed in 400 Hz and adjust record level controls to obtain 0 dB on the level meters. 2. Record signals on the reference EXII tape (DA09021A), reference SX tape (DA09025A), or reference ZX tape (DA09037A). 3. Repeating 2 as above, play back the tape and adjust VR105 (VR205) (for EXII), VR104 (VR204) (for SX) or VR103 (VR203) (for ZX) to obtain maximum reading on the VTVM. 4. Conduct step 12 "Record Level Calibration". 5. Feed in 10 kHz (-20 dB) then record and play it back. Adjust VR105 (VR205) (for EXII), VR104 (VR204) (for SX), or VR103 (VR203) (for ZX) to obtain approximately -20 dB on the VTVM. Feed in 20 kHz (-20 dB) then record and play it back. Adjust recording peaking coil L103 (L203) to approximately -20 dB on the VTVM (refer to step 10 "Record Amplifier Equalizer"). 6. Conduct Step 12 "Record Level Calibration". 7. Feed in 400 Hz and adjust the record level controls to obtain 0 dB on the level meters, then record and play it back and check to insure whether the Total Harmonic Distortion (T.H.D.) is less than 1.0% for EXII, 1.2% for SX and 1.0% for ZX. Feed in 20 Hz to 20 kHz (-20 dB) then record and play it back, and check to insure whether the output levels are within -20 dB \pm 3 dB. 8. If T.H.D. exceeds 1.2%, the following adjustments are required: <ol style="list-style-type: none"> a. Repeat 5 as above. Adjust bias calibration semi-fixed volumes and peaking coils to obtain -22 dB instead of -20 dB on the VTVM. b. Perform step 12 "Record Level Calibration". c. Repeat 7 as above. d. If above is not sufficient, precise re-adjustment of step 8 "Playback Frequency Response", replacement of Record/Playback Head, or check of item 5.8 "Tape Travelling Adjustment" will be required. 9. Conduct step 12 "Record Level Calibration".
14	Crosstalk	1 kHz to INPUT Jacks	1 kHz Band Pass Filter and VTVM to OUTPUT Jacks	Record and Playback ZX SW - OUT SX/EX SW - SX Eq. SW - 70 μ s Dolby NR SW - OUT MPX SW - IN Tone SW - OFF		<ol style="list-style-type: none"> 1. Erase the tape with bulk eraser. 2. Adjust the record level controls to obtain 0 dB on the level meters, and record the signals on the reference SX tape (DA09025A). 3. Turn the cassette tape the other way round and play it back. 4. Measure the difference between 2 and 3.
15	Channel Separation	1 kHz to INPUT Jacks	1 kHz Band Pass Filter and VTVM to OUTPUT Jacks	Record and Playback ZX SW - OUT SX/EX SW - SX Eq. SW - 70 μ s Dolby NR SW - OUT MPX SW - IN Tone SW - OFF		<ol style="list-style-type: none"> 1. Erase the tape with bulk eraser. 2. Adjust L ch (R ch) record level control to obtain 0 dB on the level meter, and turn balance control fully counterclockwise (clockwise). 3. Record and play it back, then measure the R ch (L ch) level.
16	Erasure	100 Hz to INPUT Jacks	100 Hz Band Pass Filter and VTVM to OUTPUT Jacks	Record and Playback ZX SW - IN Eq. SW - 70 μ s Dolby NR SW - OUT MPX SW - IN Tone SW - OFF		<ol style="list-style-type: none"> 1. Erase the tape with bulk eraser. 2. Adjust record level controls to obtain 0 dB on the level meters, and record the signals on the reference ZX tape (DA09037A). 3. Rewind the tape, close record level controls, and then record again. 4. Rewind the tape, play it back, and then measure the difference between 2 and 3.
17	Signal to Noise Ratio	400 Hz to INPUT Jacks	IHF-A Curve Filter, Distortion Meter and VTVM to OUTPUT Jacks	Record and Playback ZX SW - IN Eq. SW - 70 μ s Dolby NR SW - IN MPX SW - IN Tone SW - OFF		<ol style="list-style-type: none"> 1. Feed in 400 Hz and record, and play it back. 2. Adjust the record level controls to obtain 3% total harmonic distortion in playback mode. 3. Close the record level controls then record. 4. After rewind, play back and check the output level difference between 2 and 3. <p>Note: The filter of IHF-A curve shall be used in the measurements.</p>

STEP	ITEM	SIGNAL SOURCE	OUTPUT CONNECTION	MODE	ADJUSTMENT	REMARKS
18	Total Harmonic Distortion	400 Hz to Input Jacks	Distortion Meter to OUTPUT Jacks	Record and Playback ZX SW – IN/OUT SX/EX SW – SX/EX Eq. SW – 120 μ s (EX) 70 μ s (SX/ZX) Dolby NR SW – OUT MPX SW – IN Tone SW – OFF		1. Adjust the record level controls to obtain 0 dB on the level meters. 2. Record and play it back. 3. Read the distortion meter and check to insure that the distortion is as follows: EXII 1.0% or less SX 1.2% or less ZX 1.0% or less
19	Wow/Flutter	3 kHz Speed and Wow/Flutter Tape (DA09006A)	Wow/Flutter Meter to OUTPUT Jacks	Playback Eq. SW – 70 μ s		Playback and read the wow/flutter meter.

7.2. Frequency Response Adjustment

7.2.1. Playback Frequency Response Adjustment

Fig. 7.10 shows the Playback equalization curve for N-580M, and Fig. 7.11 is the circuit for adjustment.

(1) Level Adjustment (for middle frequency response)

This adjustment will be required when playback level is not sufficient at 10 kHz PB Frequency Response Tape (refer to step 8 in "7.1 Adjustment and Measurement Instructions").

Playback equalization level can be varied by the modification of R143 (R243) and R144 (R244).

Following are the details for level modification:

- Approx. +1 dB R143 (R243): 3.0K
R144 (R244): 4.3K
- 0 dB R143 (R243): 3.3K
R144 (R244): 4.7K
- Approx. -1 dB R143 (R243): 3.6K
R144 (R244): 5.1K

(2) Peaking Adjustment (for high frequency response)

This adjustment will be required when playback level is not sufficient at 20 kHz PB Frequency Response Tape (refer to step 8 in "7.1 Adjustment and Measurement Instructions").

Peaking portion compensates the gap loss of the playback head.

Peaking level is varied by the short circuit of R145 (R245) or R146 (R246) as illustrated in the figure.

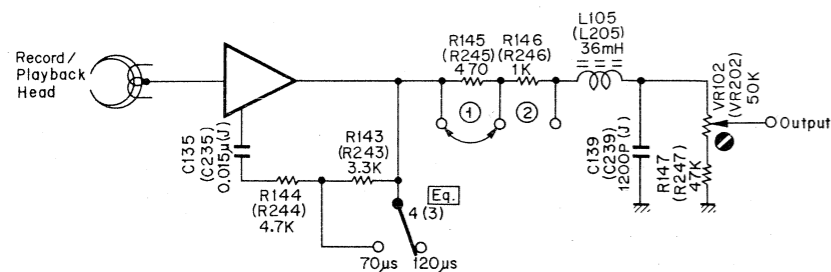

Fig. 7.11 Playback Amp.

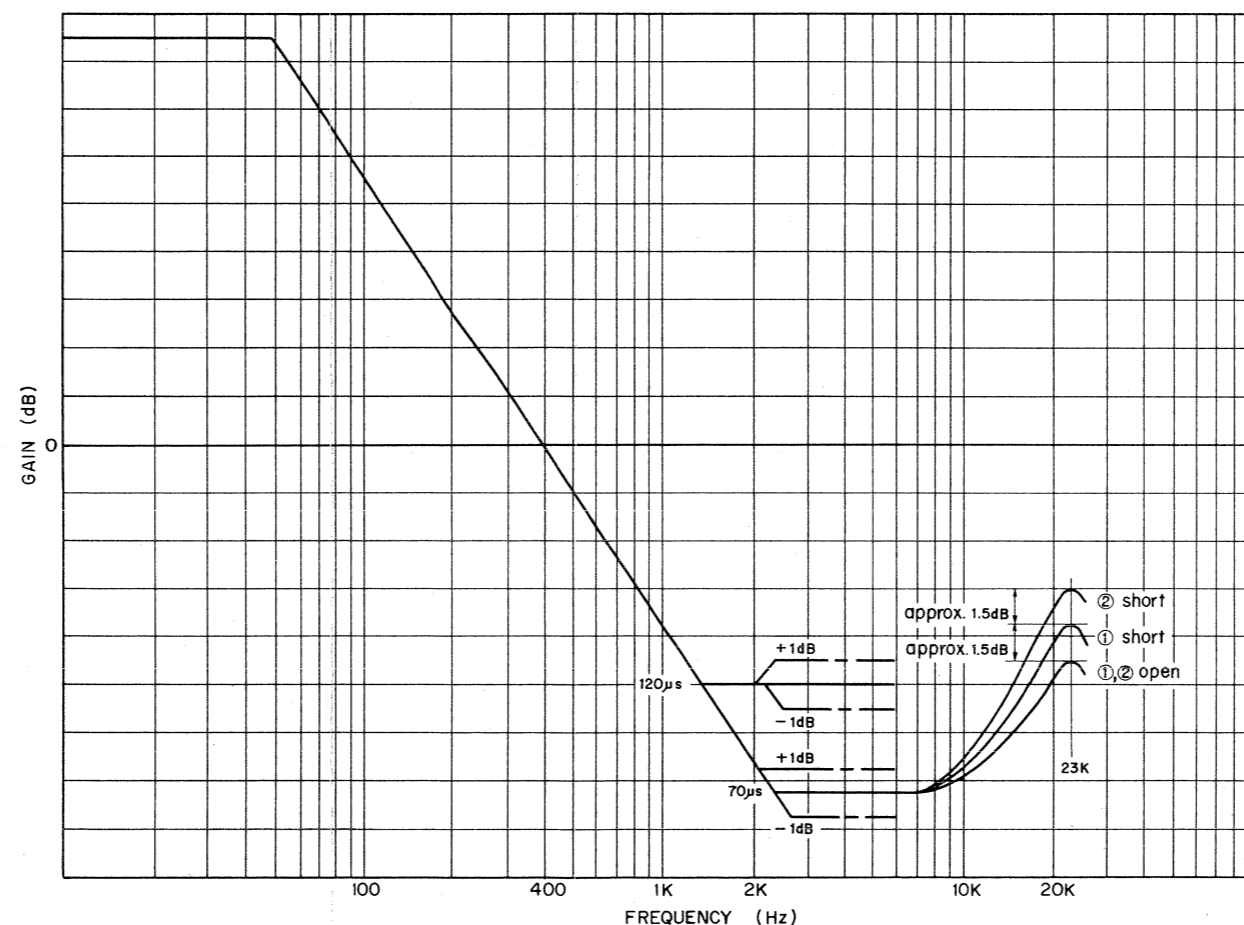

Fig. 7.10 Playback Equalization Curve

7.2.2. Record Current Frequency Response Adjustment
Record Eq. peaking is adjusted for compensating the overall frequency response when playback frequency response is completed.

Normally however peaking frequency is pre-adjusted to about 23 kHz in Record mode. Refer to Fig. 7.12.

(1) For ZX Tape

- (a) Feed in 400 Hz (0 dB), then record and play it back. Adjust bias current by VR103 (VR203) to obtain a 1% distortion.
- (b) Feed in 10 kHz and 400 Hz (-20 dB) then record and play it back. Check the difference of the levels between 10 kHz and 400 Hz, and mount an additional capacitor in parallel with the C123 (C223) from the dip side of the printed circuit board depending upon the difference of the levels against 400Hz. Refer to Fig. 7.13.

	Add	Total
0 dB	0	1000 pF
-1 dB	470 pF	1470 pF
-2 dB	1000 pF	2000 pF

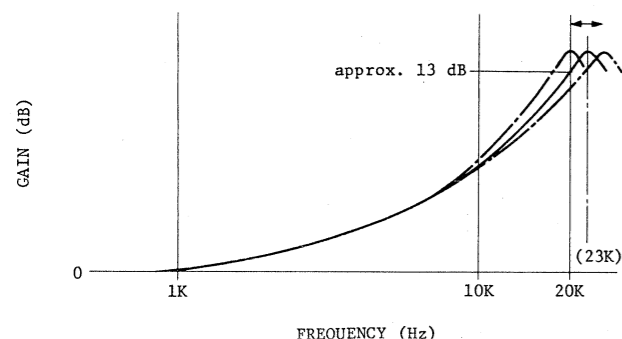

Fig. 7.12 Record Peaking Curve

- (c) Feed in 20 kHz (-20 dB) then record and play it back. Adjust record peaking coils L103 (L203) to obtain flat overall frequency response.

2) For SX Tape

- a) Feed in 10 kHz and 400 Hz (-20 dB), then record and play it back. Adjust bias current by VR104 (VR204) to obtain flat overall frequency response.
- b) Feed in 20 kHz and 400 Hz (-20 dB), then record and play it back. And check to insure that the overall frequency response is flat.

3) For EX Tape

- a) Feed in 10 kHz and 400 Hz (-20 dB), then record and play it back. Adjust bias current by VR105 (VR205) to obtain flat overall frequency response.
- b) Feed in 20 kHz and 400 Hz (-20 dB), then record and play it back. And check to insure that the overall frequency response is flat.

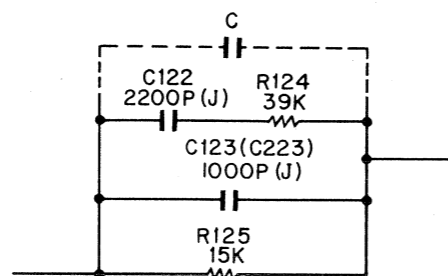

Fig. 7.13

7.3. Dolby NR Circuit Check

Dolby NR circuit incorporates a Dolby B-Type NR IC (μ A7300PC) which has no adjustment point.

Perform the following checks and make sure that the IC operates accurately i.e. frequency response through IC is accurate.

- Signal Source: 5 kHz to INPUT Jacks
- Output Connection: VTVM to the output side of C121 (C221) on the Main P.C.B.
- Mode: Record Pause
MPX SW - IN

- (1) Remove the Bias-cut Jumper from the dip side of the Main P.C.B.
- (2) Connect a VTVM to TP101 (TP201) on the Main P.C.B. Feed in 5 kHz and adjust the input level so that the VTVM may read 100 mV (0 dB) at each Test Point. Pointer on the meter will indicate 0 dB.
- (3) Remove the VTVM from TP101 (TP201) and reconnect it to the output side of C121 (C221). Check to insure that the VTVM indicates about 560 mV.
- (4) Decrease the input level (0 dB) by 20 dB or 30 dB. Check to insure that the level at output side of C121 (C221) corresponds to the following table with the Dolby NR switch IN and OUT.
- (5) After completion of the adjustment, reconnect the Bias-cut Jumper.

Input Level (f=5 kHz)	Capacitor Output Level		
	Dolby NR OUT	Dolby NR IN	Difference between IN and OUT
-20 dB	-20 dB	-16.8 dB \pm 1.5 dB	3.2 dB \pm 1.5 dB
-30 dB	-30 dB	-21.8 dB \pm 1.5 dB	8.2 dB \pm 1.5 dB

8. MOUNTING DIAGRAMS AND PARTS LIST

Note: Mounting diagram shows a dip side view of the printed circuit board.

8.1. Main P.C.B. Ass'y

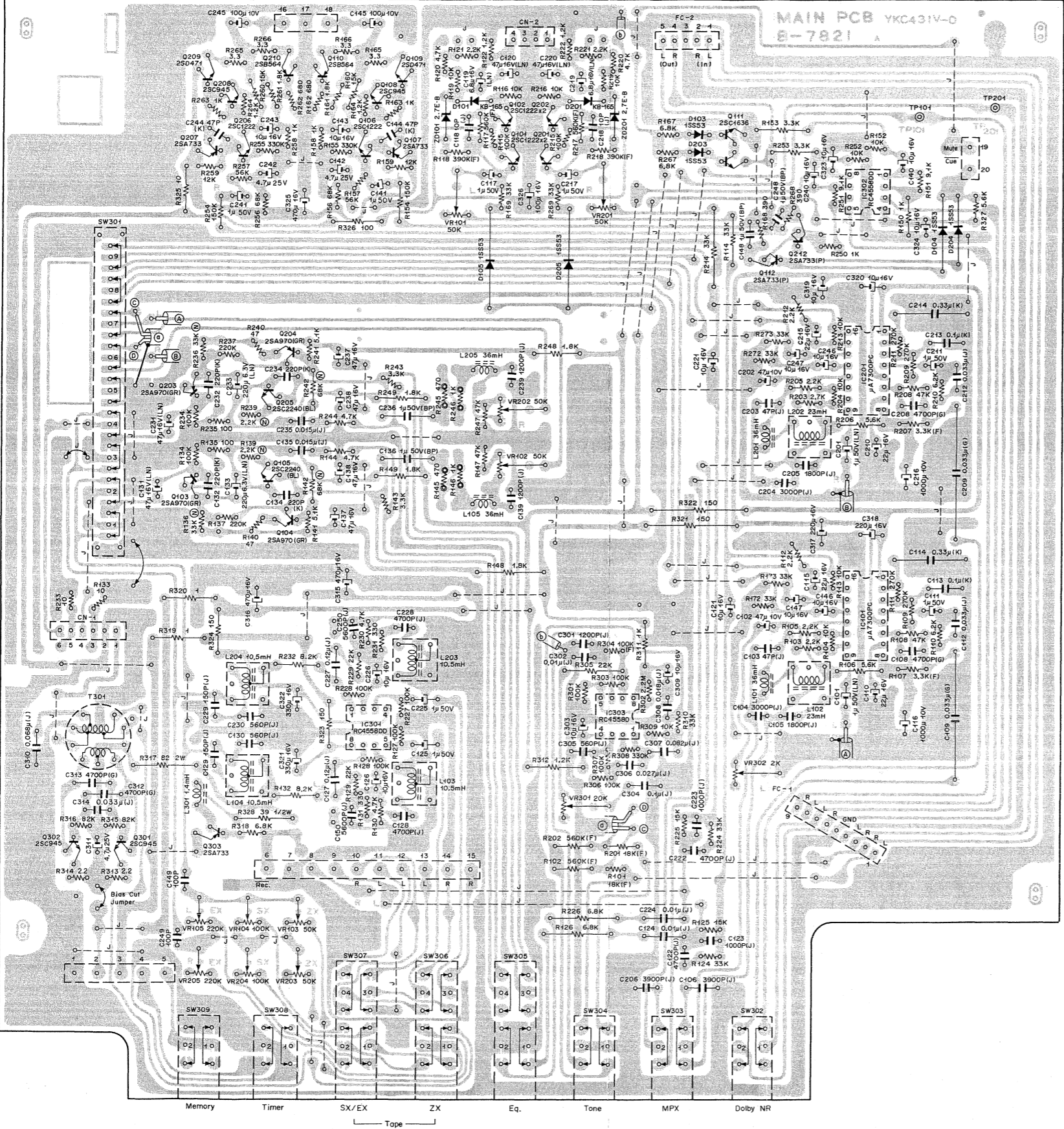

Note: Diode is 1SS53, 1S953, or 1S1555 unless otherwise specified.

Fig. 8.1

8.2. Logic P.C.B. Ass'y

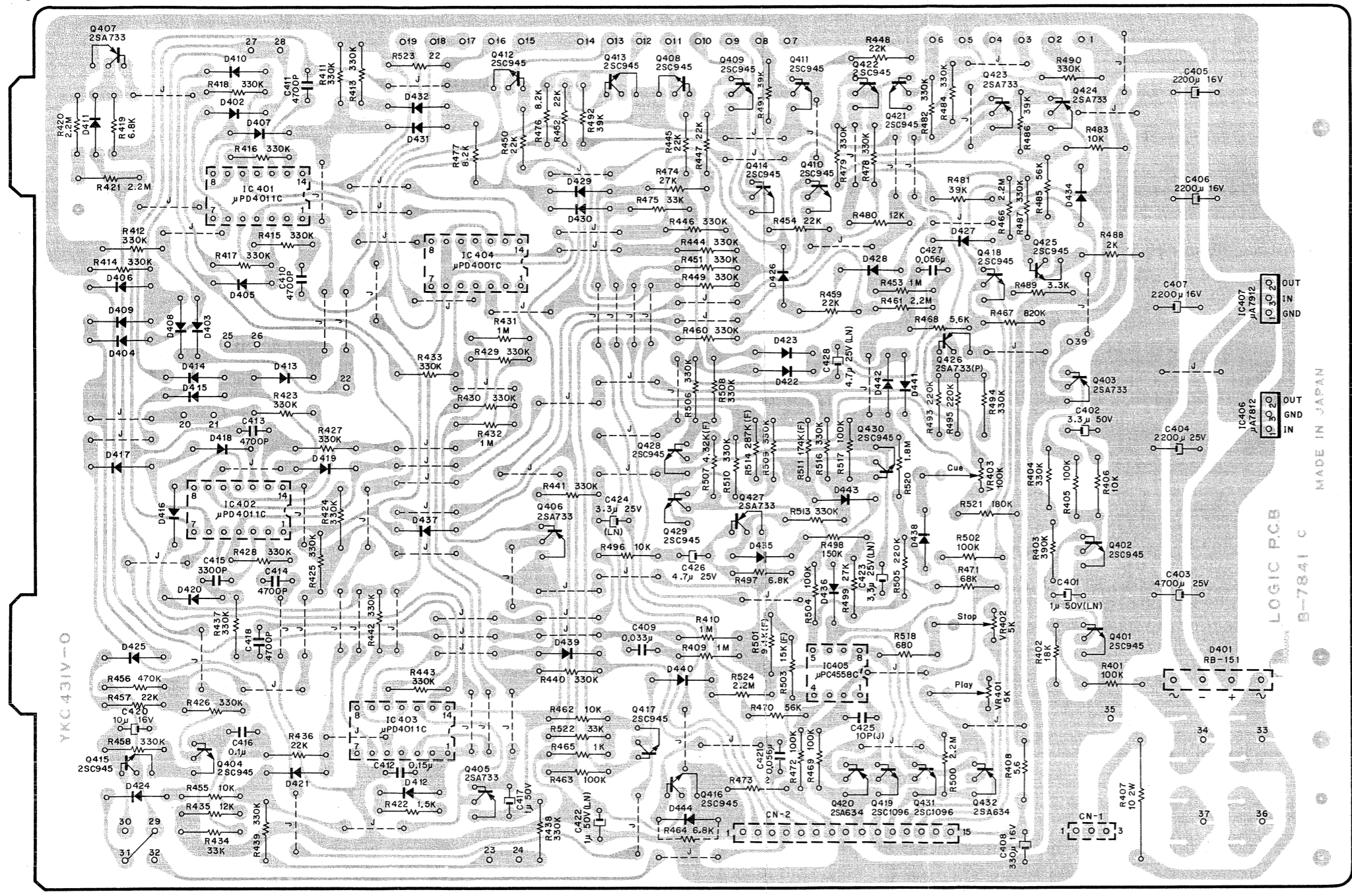

Fig. 8.2.1

Note: Diode is 1SS53, 1S953, or 1S1555 unless otherwise specified.

Serial No.: A30302310 -

Schematic Ref. No.	Part No.	Description	Schematic Ref. No.	Part No.	Description	Schematic Ref. No.	Part No.	Description
	BA04054B	Logic P.C.B. Ass'y (U.S.A., Canada & Japan & Others)	R422	OB05698A	Carbon Resistor 1.5K ERD-25T J		OE00037A	Earth Lug B-5 (1 pce.)
	BA04055B	Logic P.C.B. Ass'y (220V Class 2, UK & Australia) Serial No.: A30302310 -	R434, 475 522	OB05509A	Carbon Resistor 33K ERD-25T J		-	Wrapping Pin (33 pcs.)
			R435, 480	OB09263A	Carbon Resistor 12K ERD-25T J	*	OB08349A	Fuse Clip (4 pcs.)
			R436, 445	OB05615A	Carbon Resistor 22K ERD-25T J	*	OB08161U	Fuse 630mAT 250V (2 pcs.)
			447, 448			*	OM04062A	Fuse Label 630mAT (1 pce.)
	OB07841C	Logic P.C.B.	450, 452					
IC401-403	OB06178A	IC μ PD4011C	454, 457					* included only in Logic P.C.B. Ass'y (BA04055B)
IC404	OB06143A	IC μ PD4001C	459					
IC405	OB06124B	IC μ PC4558C	R456	OB01684A	Carbon Resistor 470K ERD-25T J			
IC406	OB06192A	Regulator μ A7812PC	R465	OB01857A	Carbon Resistor 1K ERD-25T J			
IC407	OB06193A	Regulator μ A7912PC	R467	OB09320A	Carbon Resistor 820K ERD-25T J			
Q401, 402	OB01872A	Transistor 2SC945 (20 pcs.)	R468	OB01887A	Carbon Resistor 5.6K ERD-25T J			
404			R470, 485	OB05508A	Carbon Resistor 56K ERD-25T J			
408-418			R471	OB05692A	Carbon Resistor 68K ERD-25T J			
421, 422			R473	OB09381A	Fail Safe Type Resistor 2 RDF-25S J			
425, 428			R474, 499	OB05743A	Carbon Resistor 27K ERD-25T J			
429, 430			R476, 477	OB01856A	Carbon Resistor 8.2K ERD-25T J			
Q403, 405	OB06013A	Transistor 2SA733 (Q, P)	R481, 486	OB01854A	Carbon Resistor 39K ERD-25T J			
406, 407			491, 492					
423, 424			R488	OB09301A	Carbon Resistor 2K ERD-25T J			
427			R489	OB01681A	Carbon Resistor 3.3K ERD-25T J			
Q419, 431	OB06020A	Transistor 2SC1096	R493, 495	OB05625A	Carbon Resistor 220K ERD-25T J			
Q420, 432	OB06012A	Transistor 2SA634	505					
Q426	OB06155A	Transistor 2SA733 (P)	R498	OB05626A	Carbon Resistor 150K ERD-25T J			
D401	OB06183A	Diode Bridge RB-151	R501	OB09328A	Metal Film Resistor 9.1K SN15K2E F			
D402-432	OB06181A	Silicon Diode 1SS53 (42 pcs.)	R503	OB09340A	Metal Film Resistor 15K SN15K2E F			
434-444			R507	OB09365A	Metal Film Resistor 4.32K SN15K2E F			
VR401, 402	OB03831A	Semi-fixed Volume 5K	R511	OB09367A	Metal Film Resistor 174K SN15K2E F			
VR403	OB03832A	Semi-fixed Volume 100K	R514	OB09366A	Metal Film Resistor 287K SN15K2E F			
R401, 405	OB01889A	Carbon Resistor 100K ERD-25T J	R518	OB05794A	Carbon Resistor 680 ERD-25T J			
463, 469			R520	OB05680A	Carbon Resistor 1.8M ERD-25T J			
472, 502			R521	OB05640A	Carbon Resistor 180K ERD-25T J			
504, 517			R523	OB09049A	Fail Safe Type Resistor 22 RDF-25S J			
R402	OB05560A	Carbon Resistor 18K ERD-25T J	C401, 422	OB09223A	Electrolytic Capacitor 1 μ 50V (LN)			
R403	OB05676A	Carbon Resistor 390K ERD-25T J	C402	OB01863A	Electrolytic Capacitor 3.3 μ 50V			
R404	OB05627A	Carbon Resistor 330K ERD-25T J	C403	OB09250A	Electrolytic Capacitor 4700 μ 25V			
411-418			C404	OB05654A	Electrolytic Capacitor 2200 μ 25V			
423-430			C405, 406	OB01406A	Electrolytic Capacitor 2200 μ 16V			
433			407					
437-444			C408	OB01502A	Electrolytic Capacitor 330 μ 16V			
446, 449			C409	OB05513A	Mylar Capacitor 0.033 μ 50V			
451, 458			C410, 411	OB05556A	Mylar Capacitor 4700P 50V			
460, 478			413, 414					
479, 482			418					
484, 487			C412	OB09171A	Mylar Capacitor 0.15 μ 50V			
490, 494			C415	OB09166A	Mylar Capacitor 3300P 50V			
506, 508			C416	OB00093A	Mylar Capacitor 0.1 μ 50V			
509, 510			C417	OB01405A	Electrolytic Capacitor 1 μ 50V			
513, 516			C420	OB01412A	Electrolytic Capacitor 10 μ 16V			
R406, 455	OB01888A	Carbon Resistor 10K ERD-25T J	C421, 427	OB01676A	Mylar Capacitor 0.056 μ 50V			
462, 483			C423, 424	OB09147A	Electrolytic Capacitor 3.3 μ 25V (LN)			
496			C425	OB09277A	Ceramic Capacitor 10P 50V J			
R407	OB09179A	Fail Safe Type Resistor 10 SF2B J	C426	OB01402A	Electrolytic Capacitor 4.7 μ 25V			
R408	OB05940A	Fail Safe Type Resistor 5.6 ERD-14F J	C428	OB09333A	Electrolytic Capacitor 4.7 μ 25V (LN)			
R409, 410	OB05776A	Carbon Resistor 1M ERD-25T J		OB08579A	15P-S Post (1 pce.)			
431, 432				OB08184A	3P-S Post (1 pce.)			
453				OB08568B	Heat Sink A301 (1 pce.)			
R419, 464	OB01682A	Carbon Resistor 6.8K ERD-25T J		OB08603A	Mica for Transistor (2 pcs.)			
497				OB08604A	Bushing for Transistor (2 pcs.)			
R420, 421	OB05671A	Carbon Resistor 2.2M ERD-25T J		OE00607A	Screw M3x8 Philips Pan Head (2 pcs.)			
461, 466				OE00507A	Nut Hex. M3 (2 pcs.)			
500, 524				OE00857A	BT Screw M3x6 Philips Binding Head (2 pcs.)			

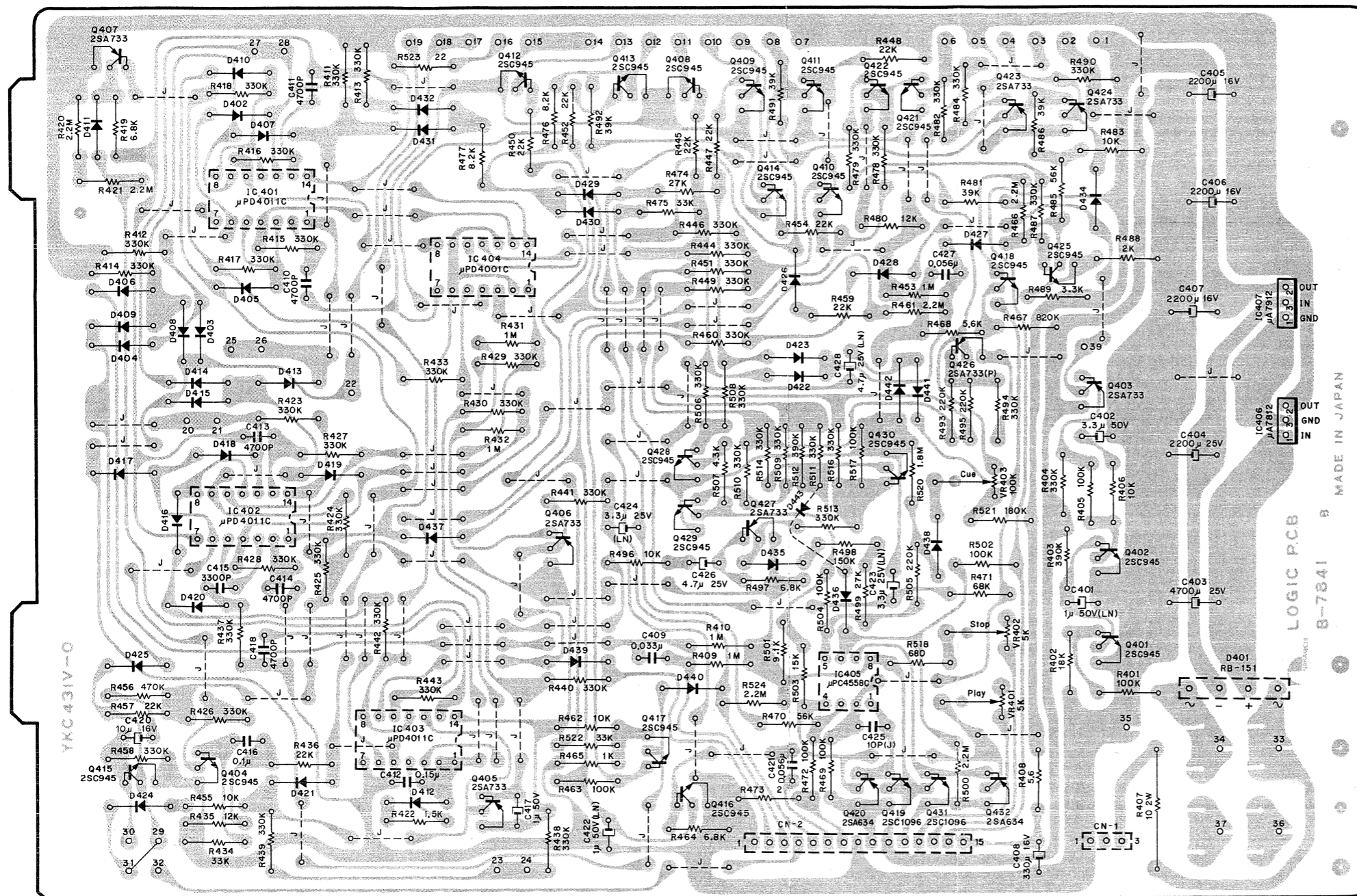

Fig. 8.2.2
Serial Nos.: A30301001 - A30302309

Note: Diode is 1S553, 1S953, or 1S1555 unless otherwise specified.

8.3. Lamp P.C.B. Ass'y

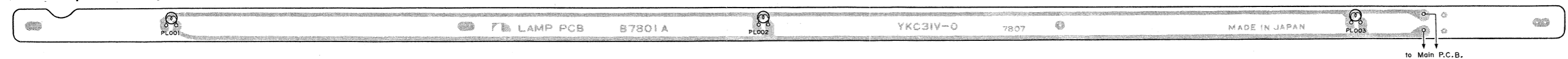

Fig. 8.3

Schematic Ref. No.	Part No.	Description	Schematic Ref. No.	Part No.	Description	Schematic Ref. No.	Part No.	Description
	BA04054A	Logic P.C.B. Ass'y (U.S.A., Canada & Japan & Others)	R420, 421	0B05671A	Carbon Resistor 2.2M ERD-25T J		0E00857A	BT Screw M3x6 Philips Binding Head (2 pcs.)
	BA04055A	Logic P.C.B. Ass'y (220V Class 2, UK & Australia) Serial Nos.: A30301001 - A30302309	461, 466 500, 524	0B05698A	Carbon Resistor 1.5K ERD-25T J		0E00037A	Earth Lug B-5 (1 pce.)
IC401-403	0B07841B	Logic P.C.B.	R422	0B05509A	Carbon Resistor 33K ERD-25T J	*	-	Wrapping Pin (33 pcs.)
IC404	0B06178A	IC μ PD4011C	R434, 475	0B09263A	Carbon Resistor 12K ERD-25T J	*	0B08349A	Jumper Wire (85 pcs.)
IC405	0B06143A	IC μ PD4001C	522	0B05615A	Carbon Resistor 22K ERD-25T J	*	0B08161U	Fuse Clip (4 pcs.)
IC406	0B06124B	IC μ PC4558C	R435, 480			*	0B08161U	Fuse 630mAT 250V (2 pcs.)
IC407	0B06192A	Regulator μ A7812PC	R436, 445				0M04062A	Fuse Label 630mAT (1 pce.)
Q401, 402	0B06193A	Regulator μ A7912PC	447, 448					* included only in Logic P.C.B. Ass'y (BA04055A)
404	0B01872A	Transistor 2SC945 (20 pcs.)	450, 452					
408-418			454, 457					
421, 422			459					
425, 428			R456	0B01684A	Carbon Resistor 470K ERD-25T J		BA03974A	Lamp P.C.B. Ass'y
429, 430			R465	0B01857A	Carbon Resistor 1K ERD-25T J		0B07801A	Lamp P.C.B.
Q403, 405	0B06013A	Transistor 2SA733 (Q, P)	R467	0B09320A	Carbon Resistor 820K ERD-25T J	PL001,002	0B08553A	Lamp 14V 80mA
406, 407			R468	0B01887A	Carbon Resistor 5.6K ERD-25T J	003		
423, 424			R470, 485	0B05508A	Carbon Resistor 56K ERD-25T J	CN1	0B08575A	3P-H Connector A301
427			R471	0B05692A	Carbon Resistor 68K ERD-25T J			
Q419, 431	0B06020A	Transistor 2SC1096	R473	0B09381A	Fail Safe Type Resistor 2 RDF-25S J			
Q420, 432	0B06012A	Transistor 2SA634	R474, 499	0B05743A	Carbon Resistor 27K ERD-25T J			
Q426	0B06155A	Transistor 2SA733 (P)	R476, 477	0B01856A	Carbon Resistor 8.2K ERD-25T J			
D401	0B06183A	Diode Bridge RB-151	R481, 486	0B01854A	Carbon Resistor 39K ERD-25T J			
D402-432	0B06181A	Silicon Diode 1SS53 (41 pcs.)	491, 492					
434-443			R488	0B09301A	Carbon Resistor 2K ERD-25T J			
VR401, 402	0B03831A	Semi-fixed Volume 5K	R489	0B01681A	Carbon Resistor 3.3K ERD-25T J			
VR403	0B03832A	Semi-fixed Volume 100K	R493, 495	0B05625A	Carbon Resistor 220K ERD-25T J			
R401, 405	0B01889A	Carbon Resistor 100K ERD-25T J	505					
463, 469			R498	0B05626A	Carbon Resistor 150K ERD-25T J			
472, 502			R501	0B09226A	Carbon Resistor 9.1K ERD-25T J			
504, 517			R503	0B01683A	Carbon Resistor 15K ERD-25T J			
R402	0B05560A	Carbon Resistor 18K ERD-25T J	R507	0B09307A	Carbon Resistor 4.3K ERD-25T J			
R403, 512	0B05676A	Carbon Resistor 390K ERD-25T J	R518	0B05794A	Carbon Resistor 680 ERD-25T J			
R404	0B05627A	Carbon Resistor 330K ERD-25T J	R520	0B05680A	Carbon Resistor 1.8M ERD-25T J			
411-418			R521	0B05640A	Carbon Resistor 180K ERD-25T J			
423-430			R523	0B09049A	Fail Safe Type Resistor 22 RDF-25S J			
433			C401, 422	0B09223A	Electrolytic Capacitor 1 μ 50V (LN)			
437-444			C402	0B01863A	Electrolytic Capacitor 3.3 μ 50V			
446, 449			C403	0B09250A	Electrolytic Capacitor 4700 μ 25V			
451, 458			C404	0B05654A	Electrolytic Capacitor 2200 μ 25V			
460, 478			C405, 406	0B01406A	Electrolytic Capacitor 2200 μ 16V			
479, 482			407					
484, 487			C408	0B01502A	Electrolytic Capacitor 330 μ 16V			
490, 494			C409	0B05513A	Mylar Capacitor 0.033 μ 50V			
506, 508			C410, 411	0B05556A	Mylar Capacitor 4700P 50V			
509, 510			413, 414					
511, 513			418					
514, 516			C412	0B09171A	Mylar Capacitor 0.15 μ 50V			
R406, 455	0B01888A	Carbon Resistor 10K ERD-25T J	C415	0B09166A	Mylar Capacitor 3300P 50V			
462, 483			C416	0B00093A	Mylar Capacitor 0.1 μ 50V			
496			C417	0B01405A	Electrolytic Capacitor 1 μ 50V			
R407	0B09179A	Fail Safe Type Resistor 10 SF2B J	C420	0B01412A	Electrolytic Capacitor 10 μ 16V			
R408	0B05940A	Fail Safe Type Resistor 5.6 ERD-14F J	C421, 427	0B01676A	Mylar Capacitor 0.056 μ 50V			
R409, 410	0B05776A	Carbon Resistor 1M ERD-25T J	C423, 424	0B09147A	Electrolytic Capacitor 3.3 μ 25V (LN)			
431, 432			C425	0B09277A	Ceramic Capacitor 10P 50V J			
453			C426	0B01402A	Electrolytic Capacitor 4.7 μ 25V			
R419, 464	0B01682A	Carbon Resistor 6.8K ERD-25T J	C428	0B09333A	Electrolytic Capacitor 4.7 μ 25V (LN)			
497				0B08579A	15P-S Post (1 pce.)			
				0B08184A	3P-S Post (1 pce.)			
				0B08568B	Heat Sink A301 (1 pce.)			
				0B08603A	Mica for Transistor (2 pcs.)			
				0B08604A	Bushing for Transistor (2 pcs.)			
				0E00607A	Screw M3x8 Philips Pan Head (2 pcs.)			
				0E00507A	Nut Hex. M3 (2 pcs.)			

8.4. Control Switch P.C.B. Ass'y

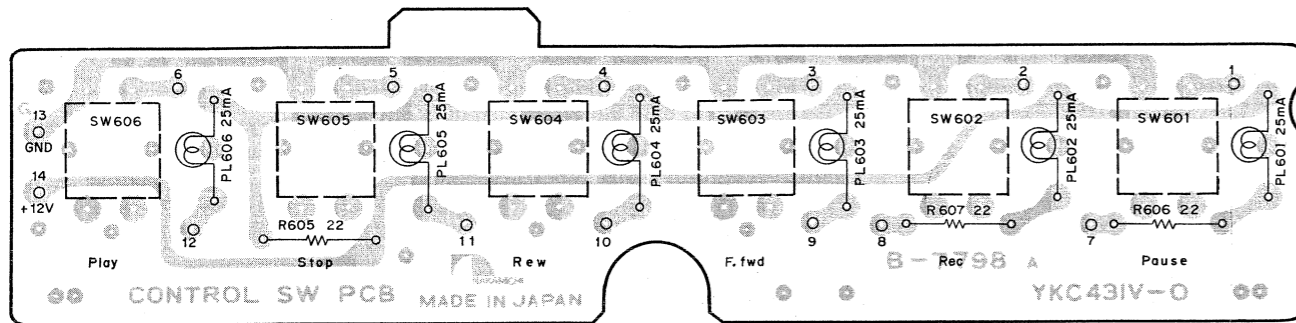

Fig. 8.4

8.5. Volume P.C.B. Ass'y

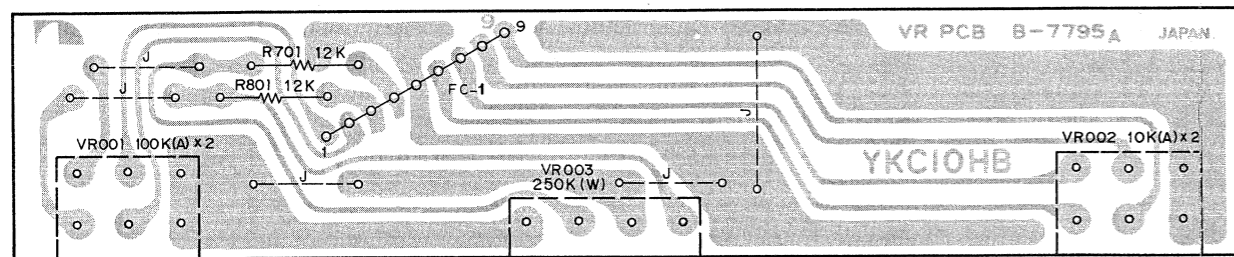

Fig. 8.5

8.6. DIN-Pin P.C.B. Ass'y

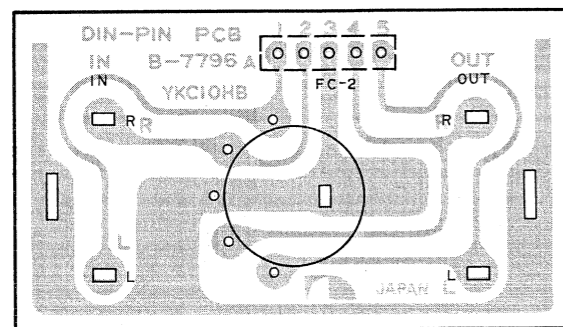

Fig. 8.6

8.7. Shut-off P.C.B. Ass'y

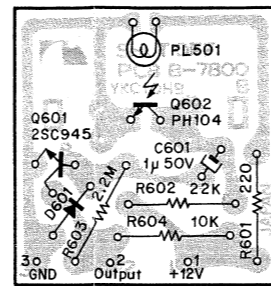

Fig. 8.7

8.8. Record Cal. P.C.B. Ass'y

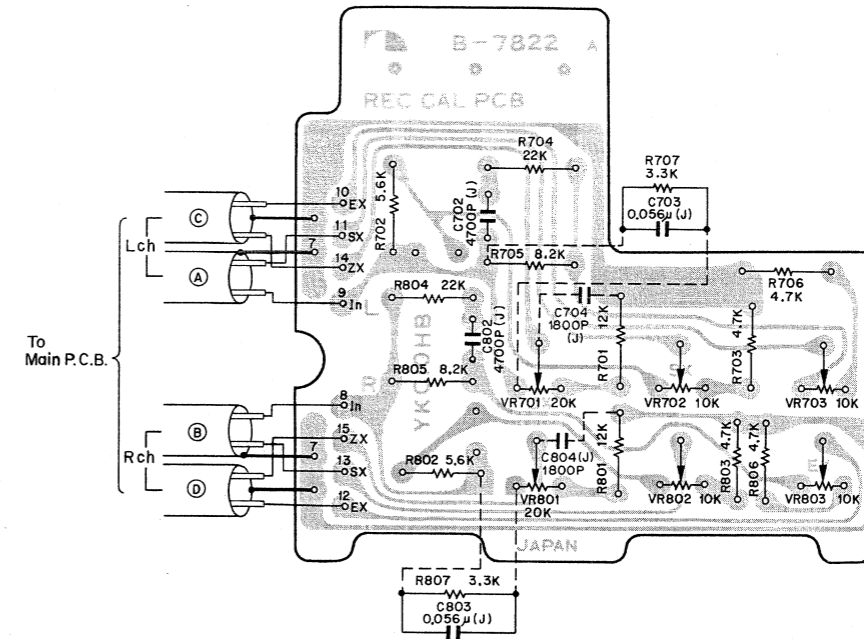

Fig. 8.8

Schematic Ref. No.	Part No.	Description	Schematic Ref. No.	Part No.	Description
	BA03976A	Control Switch P.C.B. Ass'y		BA03972A	Volume P.C.B. Ass'y
R605, 606 607	OB07798A	Control Switch P.C.B.	VR001	OB07795A	Volume P.C.B.
PL601,602 603, 604 605, 606	OB09049A	Fail Safe Type Resistor 22 RBF25S J	VR002	OB07231A	Volume 100K (A) x 2
SW601,602 603, 604 605, 606	OB08552A	Lamp 12V 25mA	VR003	OB07230A	Volume 10K (A) x 2
	OB07254A	Switch EVQ-P1R04K	R701, 801	OB07255A	Volume 250K (W)
	OB08567B	Lamp Holder (6 pcs.)	FC1	OB05771A	Carbon Resistor 12K ERD-25T J
				OB05229A	Flat Cable D
				OJ03973B	Volume Holder A301 (1 pce.)
				BA03973A	DIN-Pin P.C.B. Ass'y
			FC2	OB07796A	DIN-Pin P.C.B.
				OB05226A	Flat Cable A
				OB08097A	Jack Unit (1 pce.)
				OE00037A	Earth Lug B-5 (1 pce.)

Schematic Ref. No.	Part No.	Description	Schematic Ref. No.	Part No.	Description
	BA04076A	Shut-off Sensor P.C.B. Ass'y		BA04039A	Rec. Cal. P.C.B. Ass'y
Q601	OB07800B	Shut-off Sensor P.C.B.	VR701, 801	OB07822B	Rec. Cal. P.C.B.
Q602	OB01872A	Transistor 2SC945	VR702, 703	OB07270A	Semi-fixed Volume 20K
D601	OB06181A	Silicon Diode 1SS53	802, 803	OB07256A	Semi-fixed Volume 10K
R601	OB01933A	Carbon Resistor 220 ERD-25T J	R701, 801	OB09263A	Carbon Resistor 12K ERD-25T J
R602	OB05615A	Carbon Resistor 22K ERD-25T J	R702, 802	OB01887A	Carbon Resistor 5.6K ERD-25T J
R603	OB05671A	Carbon Resistor 2.2M ERD-25T J	R703, 706	OB01846A	Carbon Resistor 4.7K ERD-25T J
R604	OB01888A	Carbon Resistor 10K ERD-25T J	803, 806	OB05615A	Carbon Resistor 22K ERD-25T J
C601	OB01405A	Electrolytic Capacitor 1μ 50V	R704, 804	OB01856A	Carbon Resistor 8.2K ERD-25T J
PL501	OB08552A	Lamp 12V 25mA	R705, 805	OB01681A	Carbon Resistor 3.3K ERD-25T J
			C702, 802	OB05652A	Mylar Capacitor 4700P 50V J
			C703, 803	OB05813A	Mylar Capacitor 0.056μ 50V J
			C704, 804	OB01913A	Mylar Capacitor 1800P 50V J
				OB08589A	Set Pin 1mm (9 pcs.)

9. MECHANISM ASS'Y AND PARTS LIST

9.1. Synthesis

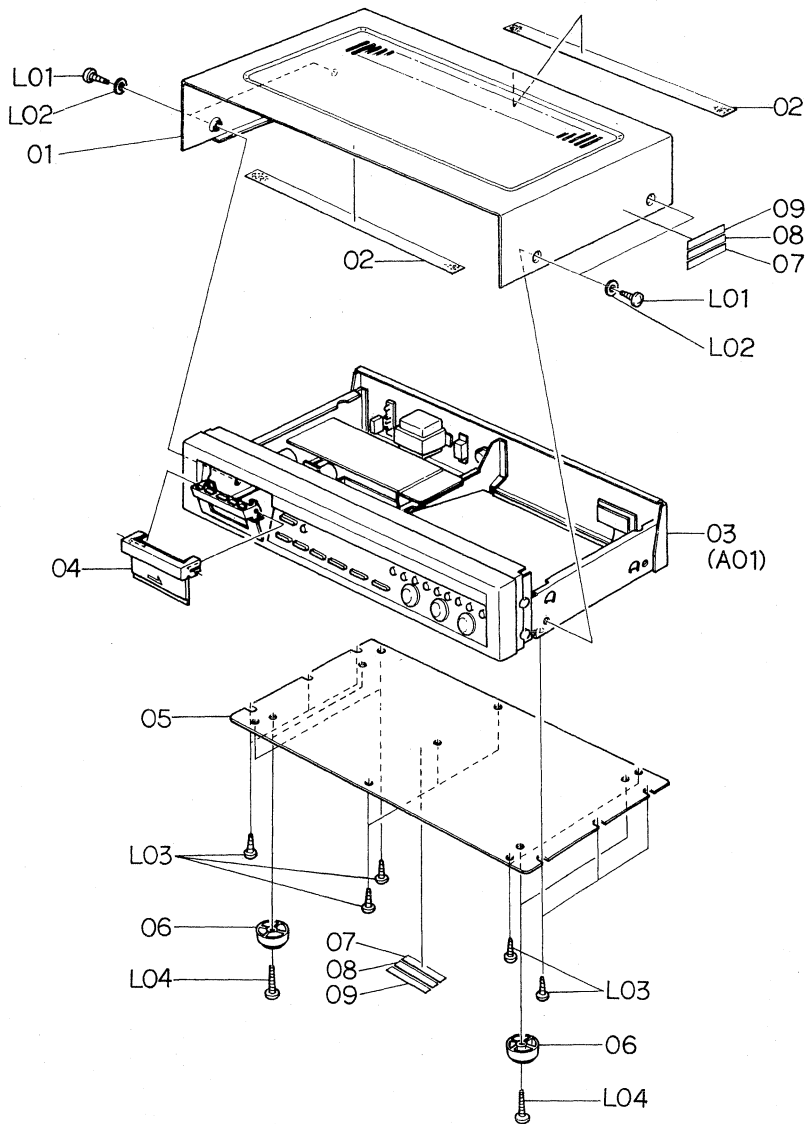

Fig. 9.1

Schematic Ref. No.	Part No.	Description	Q'ty	Schematic Ref. No.	Part No.	Description	Q'ty
	Synthesis			04	0H03689B	Acrylic Cassette Compartment Cover	1
01	0H03681C	Top Cover	1	05	0J03972B	Bottom Cover	1
02	0J03580B	Top Cover Himelon	2	06	0J03825A	Leg S	4
03	JA03519A	Synthesis Mechanism 580M (U.S.A. & Canada)	1	07	0M03799A	Caution Label G	2
	JA03520A	Synthesis Mechanism 580M (Japan)	1	08	0M03800A	Caution Label H	2
	JA03522A	Synthesis Mechanism 580M (Others)	1	09	0M03883A	Lamp Caution Label	2
	JA03523A	Synthesis Mechanism 580M (220V Class 2)	1	L01	0E00858A	BT Screw M4x6 Philips Binding Head (Black Chromate)	4
	JA03524A	Synthesis Mechanism 580M (UK)	1	L02	0E00736A	Washer 4mm (Black Chromate)	4
	JA03620A	Synthesis Mechanism 580M (Australia)	1	L03	0E00857A	BT Screw M3x6 Philips Binding Head	13
				L04	0E00852A	BT Screw M4x12 Philips Binding Head	4

9.2. Synthesis Mechanism 580M (A01)

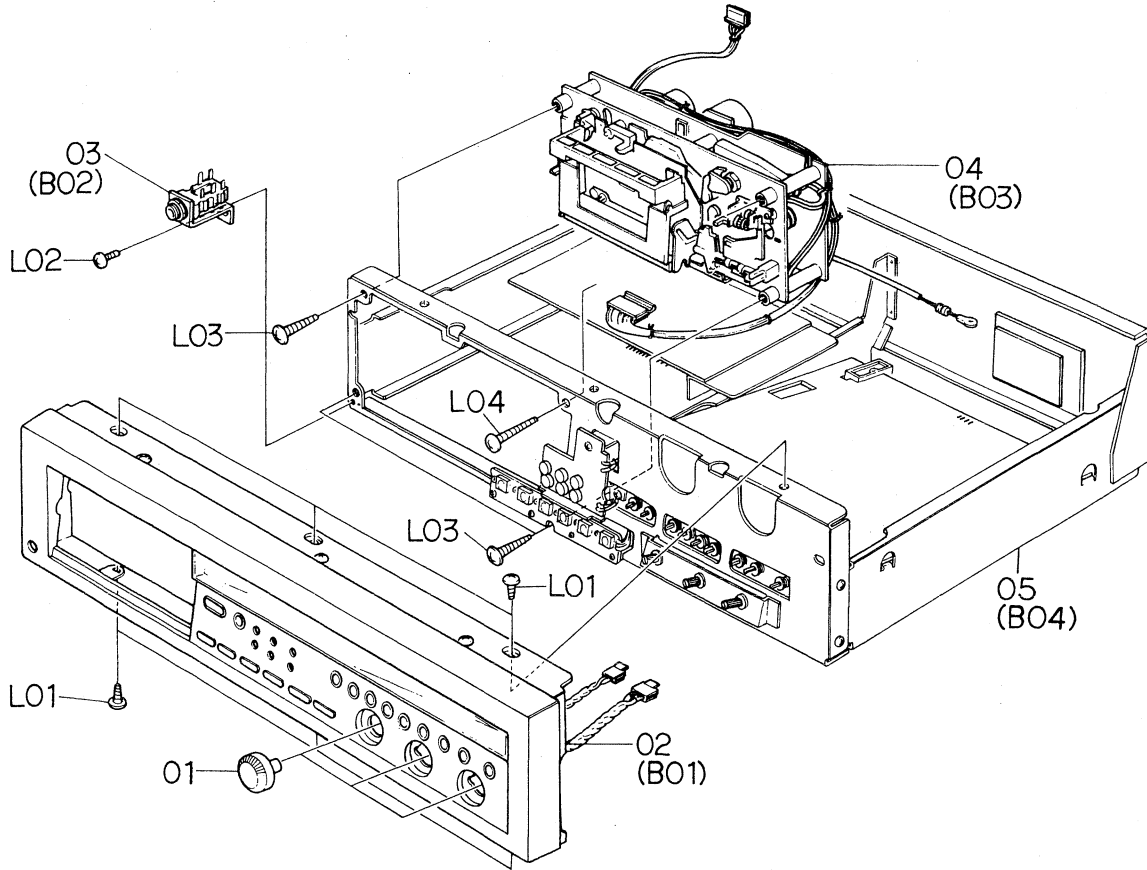

Fig. 9.2

Schematic Ref. No.	Part No.	Description	Q'ty	Schematic Ref. No.	Part No.	Description	Q'ty
A01	JA03519A	Synthesis Mechanism 580M (U.S.A. & Canada)	1	L01	0E00877A	ST Screw M3x5 Philips Binding Head	6
	JA03520A	Synthesis Mechanism 580M (Japan)	1	L02	0E00857A	BT Screw M3x6 Philips Binding Head	1
	JA03522A	Synthesis Mechanism 580M (Others)	1	L03	0E00867A	BT Screw M4x15 Philips Binding Head	3
	JA03523A	Synthesis Mechanism 580M (220V Class 2)	1	L04	0E00878A	BT Screw M4x20 Philips Binding Head	1
	JA03524A	Synthesis Mechanism 580M (UK)	1				
	JA03620A	Synthesis Mechanism 580M (Australia)	1				
01	0H03706A	Volume Knob	3				
02	HA03800A	Front Panel Ass'y 580M	1				
03	JA03390A	Headphone Jack Ass'y	1				
04	CA08067D	Mechanism Ass'y 580M	1				
05	JA03528B	Chassis Ass'y 580M (U.S.A. & Canada)	1				
	JA03529B	Chassis Ass'y 580M (Japan)	1				
	JA03531B	Chassis Ass'y 580M (Others)	1				
	JA03532B	Chassis Ass'y 580M (220V Class 2)	1				
	JA03533B	Chassis Ass'y 580M (UK)	1				
	JA03618A	Chassis Ass'y 580M (Australia)	1				

9.3. Front Panel Ass'y 580M (B01)

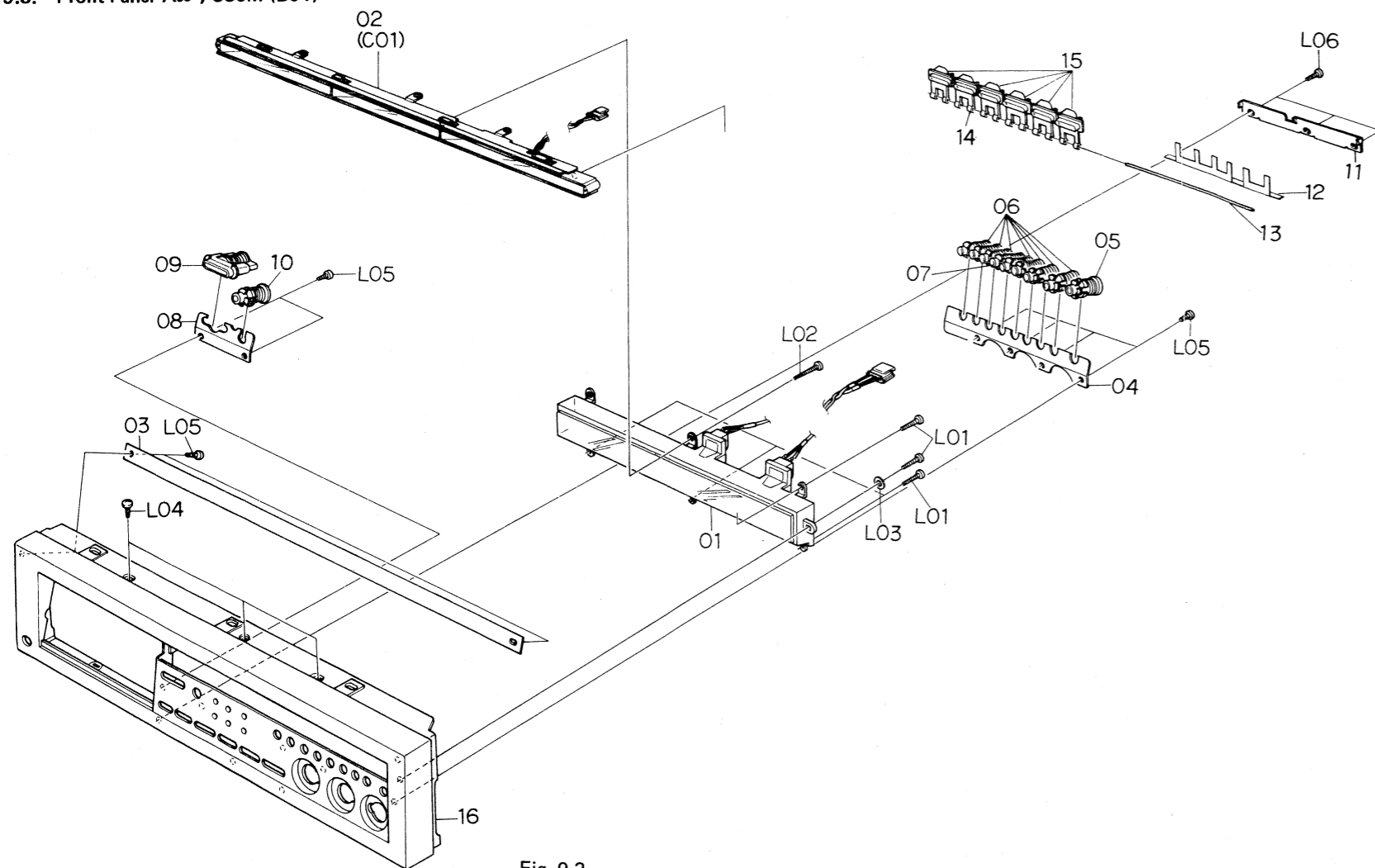

Fig. 9.3

9.4. Headphone Jack Ass'y (B02)

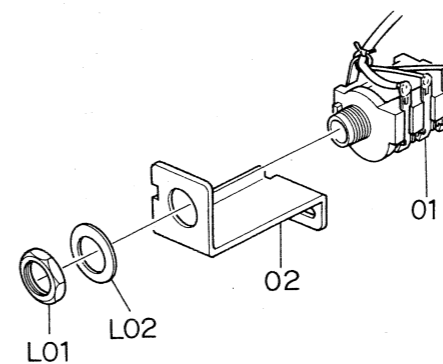

Fig. 9.4

Schematic Ref. No.	Part No.	Description	Q'ty	Schematic Ref. No.	Part No.	Description	Q'ty
B01	HA03800A	Front Panel Ass'y 580M	1	L02	0E00840A	BT Screw M2x8 Philips Pan Head	1
01	HA03776A	Meter Ass'y	1	L03	0E00100A	Washer 2mm	1
02	HA03777A	Lamp House Cover Ass'y	1	L04	0E00873A	BT Screw M2.6x5 Philips Binding Head	3
03	0H03697A	Aluminum Mirror	1	L05	0E00841A	BT Screw M2x4 Philips Pan Head	8
04	0J03978B	Flange Holder	1	L06	0E00794A	BT Screw M2x5 Philips Pan Head	3
05	HA03803A	Push Button Ass'y A	1	B02	JA03390A	Headphone Jack Ass'y	1
06	HA03804A	Push Button Ass'y B	7	01	0B08511A	Headphone Jack	1
07	HA03985A	Push Button Ass'y ZX	1	02	0J03975A	Jack Holder	1
08	0J03979B	Flange Holder	1	L01	-	Jack Nut	(1)
09	HA03805A	Push Button Ass'y C	1	L02	-	Jack Washer	(1)
10	HA03806A	Counter Reset Button Ass'y	1				
11	0J03965C	Control Button Shaft Hoder	1				
12	0J03986B	Control Button Spring	1				
13	0J03966A	Control Button Shaft	1				
14	HA03797A	Control Button A Ass'y	1				
15	HA03798A	Control Button B Ass'y	5				
16	HA03799A	Front Panel Sub Ass'y	1				
L01	0E00793A	BT Screw M2x6 Philips Pan Head	5				

9.5. Mechanism Ass'y 580M (B03)

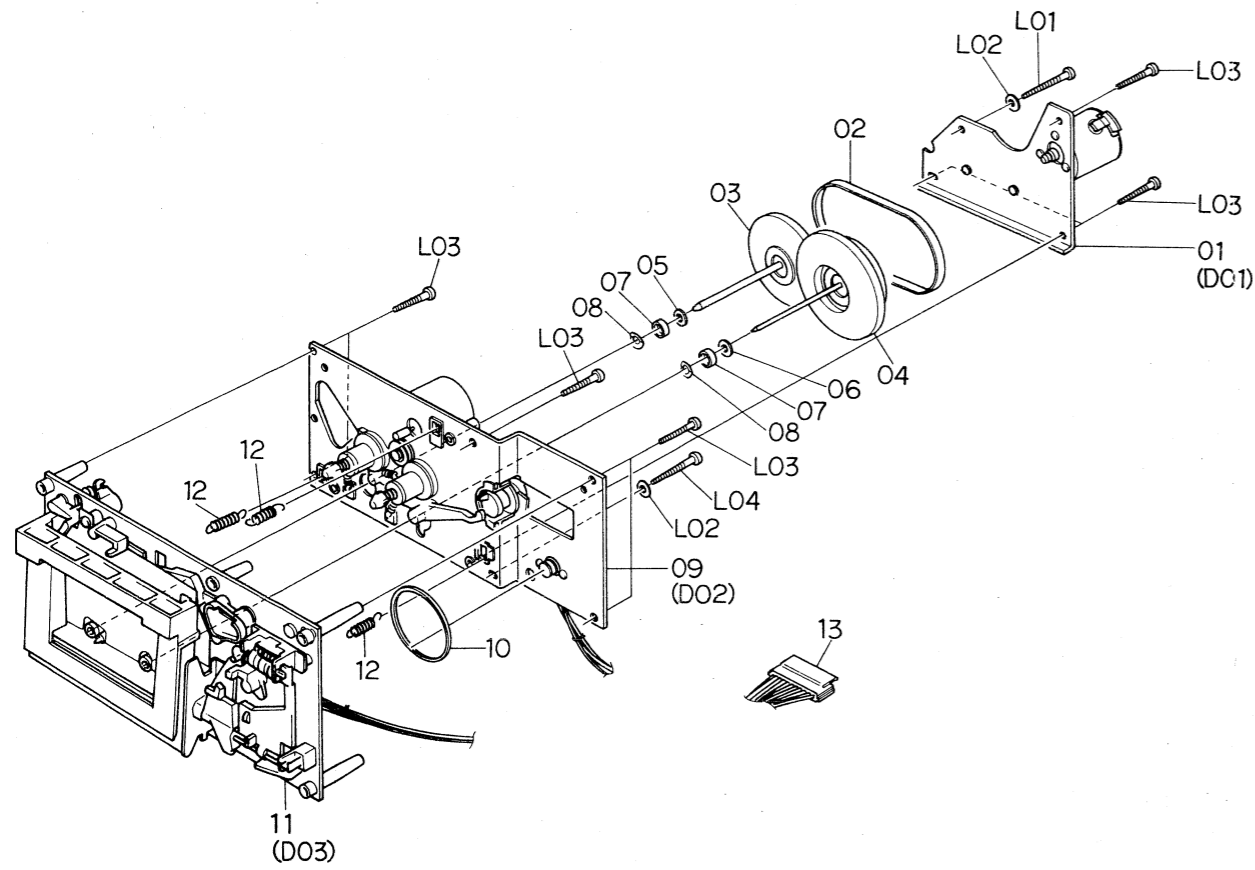

Fig. 9.5

9.6. Chassis Ass'y 580M (B04)

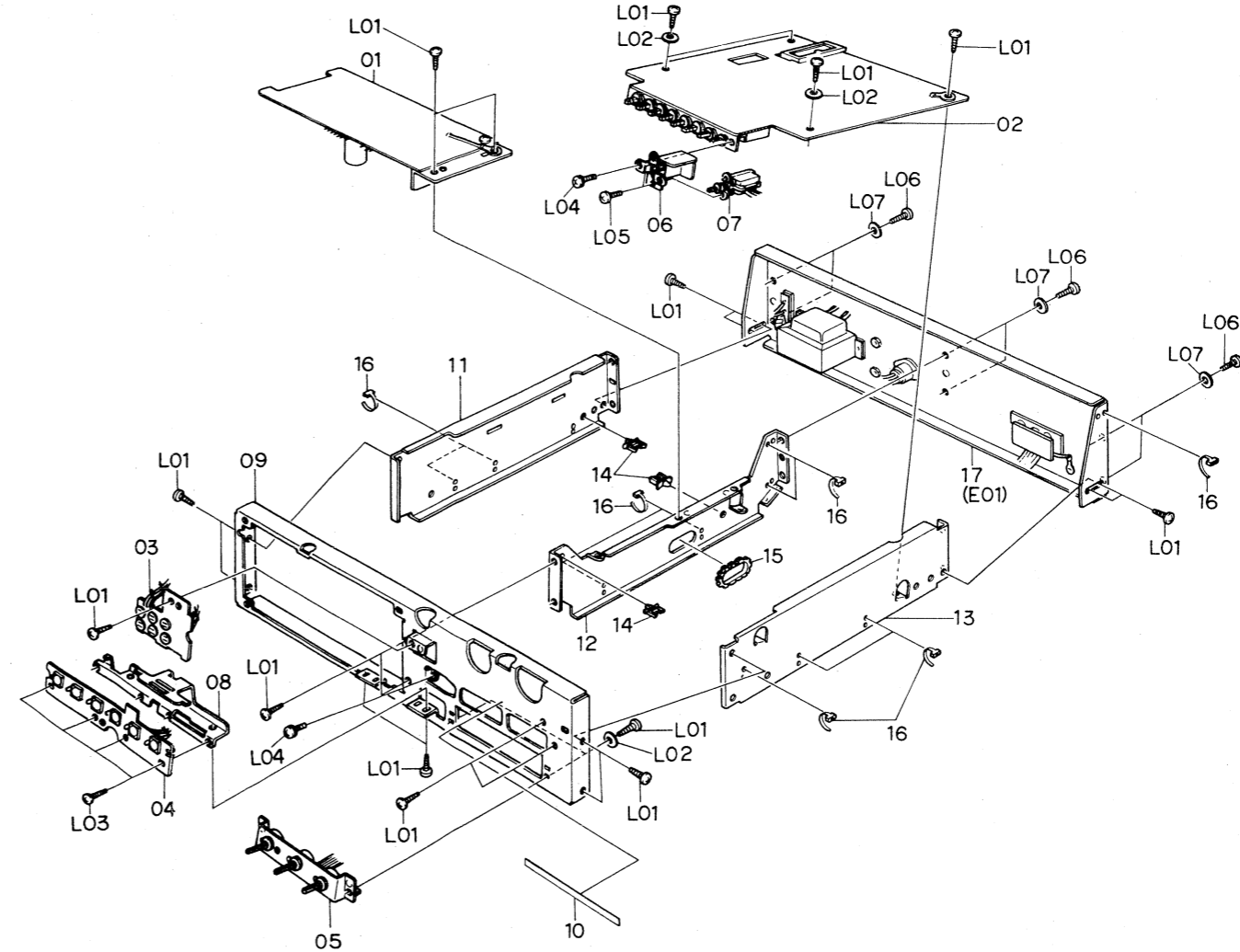

Fig. 9.6

Schematic Ref. No.	Part No.	Description	Q'ty
B03	CA08067D	Mechanism Ass'y 580M	1
01	CA08017B	Flywheel Holder Ass'y	1
02	0C08096C	Capstan Belt	1
03	CA08014A	Supply Flywheel Ass'y	1
04	CA08015A	Take-up Flywheel Ass'y	1
05	0C08021B	Thrust Washer 3.1mm	1
06	0C08020B	Thrust Washer 2.6mm	1
07	0C08069C	Flange Thrust Cap	2
08	0C08022B	Flange Thrust Spring	2
09	CA08132A	Sub Mechansim Chassis Ass'y	1
10	0C08099B	Control Motor Belt	1
11	CA08166A	Main Mechansim Chassis Ass'y	1
12	0C08175A	Head Base L Spring	3
13	0B08578C	15P-H Connector	1
-	0B08515A	Insu-Lock	7
L01	0E00834A	BT Screw M3x30 Philips Pan Head	1
L02	0E00178A	Washer 3 mm	2
L03	0E00833A	BT Screw M3x20 Philips Pan Head	8
L04	0E00835A	BT Screw M3x25 Philips Pan Head	1

Schematic Ref. No.	Part No.	Description	Q'ty	Schematic Ref. No.	Part No.	Description	Q'ty
B04	JA03528B	Chassis Ass'y 580M (U.S.A. & Canada)	1	B04	JA03528A	Chassis Ass'y 580M (U.S.A. & Canada)	1
	JA03529B	Chassis Ass'y 580M (Japan)	1		JA03529A	Chassis Ass'y 580M (Japan)	1
	JA03531B	Chassis Ass'y 580M (Others)	1		JA03531A	Chassis Ass'y 580M (Others)	1
	JA03532B	Chassis Ass'y 580M (220V Class 2)	1		JA03532A	Chassis Ass'y 580M (220V Class 2)	1
	JA03533B	Chassis Ass'y 580M (UK)	1		JA03533A	Chassis Ass'y 580M (UK)	1
	JA03618A	Chassis Ass'y 580M (Australia) Serial No.: A30302310 -	1		JA03618A	Chassis Ass'y 580M (Australia) Serial Nos.: A30301001 - A30302309	1
01	BA04054B	Logic P.C.B. Ass'y (U.S.A., Canada, Japan & Others)	1	01	BA04054A	Logic P.C.B. Ass'y (U.S.A., Canada, Japan & Others)	1
	BA04055B	Logic P.C.B. Ass'y (220V Class 2, UK & Australia)	1		BA04055A	Logic P.C.B. Ass'y (220V Class 2, UK & Australia)	1
02	BA04038A	Main P.C.B. Ass'y	1	02	BA04038A	Main P.C.B. Ass'y	1
03	BA04039A	Record Cal. P.C.B. Ass'y	1	03	BA04039A	Record Cal. P.C.B. Ass'y	1
04	BA03976A	Control Switch P.C.B. Ass'y	1	04	BA03976A	Control Switch P.C.B. Ass'y	1
05	BA03972A	Volume P.C.B. Ass'y	1	05	BA03972A	Volume P.C.B. Ass'y	1
06	0J03974B	Power Switch Holder	1	06	0J03974B	Power Switch Holder	1
07	0B07253A	Power Switch (U.S.A., Canada & Others)	1	07	0B07253A	Power Switch (U.S.A., Canada & Others)	1
	0B07252A	Power Switch (220V Class 2, UK & Australia)	1		0B07252A	Power Switch (220V Class 2, UK & Australia)	1
	0B07271A	Power Switch (Japan)	1		0B07271A	Power Switch (Japan)	1
08	0J03976B	Control Switch Holder	1	08	0J03976B	Control Switch Holder	1
09	0J03967E	Front Chassis	1	09	0J03967E	Front Chassis	1
10	0M04057A	Push Switch Label	1	10	0M04057A	Push Switch Label	1
11	0J03969C	Side Chassis L	1	11	0J03969C	Side Chassis L	1
12	0J03968D	Side Chassis R	1	12	0J03968D	Side Chassis R	1
13	0J03970D	Center Chassis	1	13	0J03970D	Center Chassis	1
14	0B08580A	Wire Holder 161	3	14	0B08580A	Wire Holder 161	3
15	0B08590A	Free Bushing 80mm	1	15	0B08590A	Free Bushing 80mm	1
16	0B08515A	Insu-Lock	15	16	0B08515A	Insu-Lock	15
17	JA03537A	Rear Panel Ass'y (U.S.A. & Canada)	1	17	JA03537A	Rear Panel Ass'y (U.S.A. & Canada)	1
	JA03538A	Rear Panel Ass'y (Japan)	1		JA03538A	Rear Panel Ass'y (Japan)	1
	JA03539A	Rear Panel Ass'y (Others)	1		JA03539A	Rear Panel Ass'y (Others)	1
	JA03540A	Rear Panel Ass'y (220V Class 2)	1		JA03540A	Rear Panel Ass'y (220V Class 2)	1
	JA03541A	Rear Panel Ass'y (UK)	1		JA03541A	Rear Panel Ass'y (UK)	1
	JA03619A	Rear Panel Ass'y (Australia)	1		JA03619A	Rear Panel Ass'y (Australia)	1
L01	0E00857A	BT Screw M3x6 Philips Binding Head	23	L01	0E00857A	BT Screw M3x6 Philips Binding Head	23
L02	0E00637A	Washer 3.3mm	5	L02	0E00637A	Washer 3.3mm	5
L03	0E00859A	BT Screw M2.6x6 Philips Binding Head	4	L03	0E00859A	BT Screw M2.6x6 Philips Binding Head	4
L04	0E00622A	Screw M3x5 Philips Pan Head (2A)	2	L04	0E00622A	Screw M3x5 Philips Pan Head (2A)	2
L05	0E00502A	Screw M3x5 Philips Pan Head	2	L05	0E00502A	Screw M3x5 Philips Pan Head	2
L06	0E00860A	BT Screw M3x6 Philips Binding Head (Black Chromate)	6	L06	0E00860A	BT Screw M3x6 Philips Binding Head (Black Chromate)	6
L07	0E00157A	Washer 3mm (Black Plastics)	6	L07	0E00157A	Washer 3mm (Black Plastics)	6

9.7. Lamp House Cover Ass'y (C01)

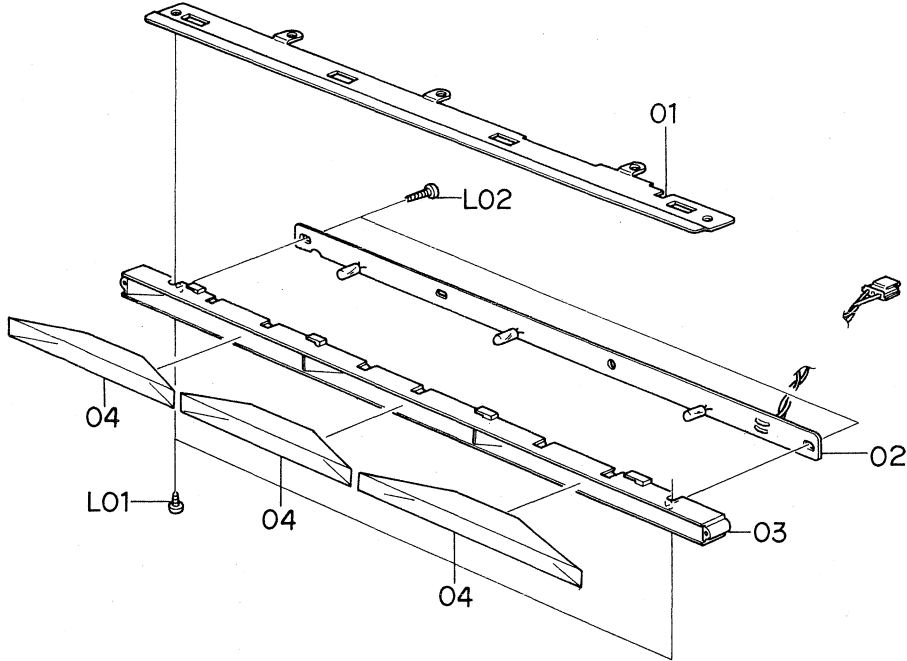

Fig. 9.7

9.8. Flywheel Holder Ass'y (D01)

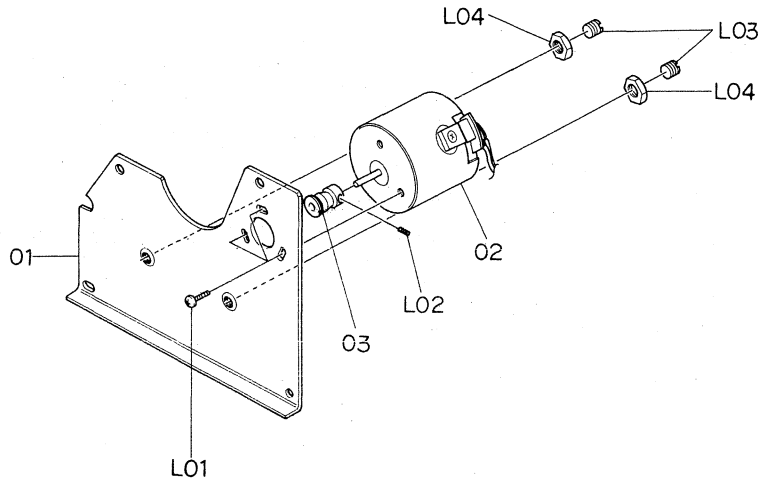

Fig. 9.8

Schematic Ref. No.	Part No.	Description	Q'ty	Schematic Ref. No.	Part No.	Description	Q'ty
C01	HA03777A	Lamp House Cover Ass'y	1	D01	CA08017B	Flywheel Holder Ass'y	1
01	OJ03977B	Lamp House Cover Holder	1	01	0C08013I	Flywheel Holder	1
02	BA03974A	Lamp P.C.B. Ass'y	1	02	0C08135A	Capstan Motor	1
03	0H03673A	Lamp House Cover	1	03	0C08079F	Capstan Motor Pulley	1
04	0H03674D	Lamp House	3	L01	0E00226A	Screw M2.6x4 Philips Pan Head	3
L01	0E00853A	BT Screw M2x3 Philips Pan Head	2	L02	0E00626A	Screw M2x3 Cup Point	1
L02	0E00793A	BT Screw M2x6 Philips Binding Head	2	L03	0C08068C	Thrust Screw	2
				L04	0C03857A	Lock Nut	1

9.9. Sub Mechanism Chassis Ass'y (D02)

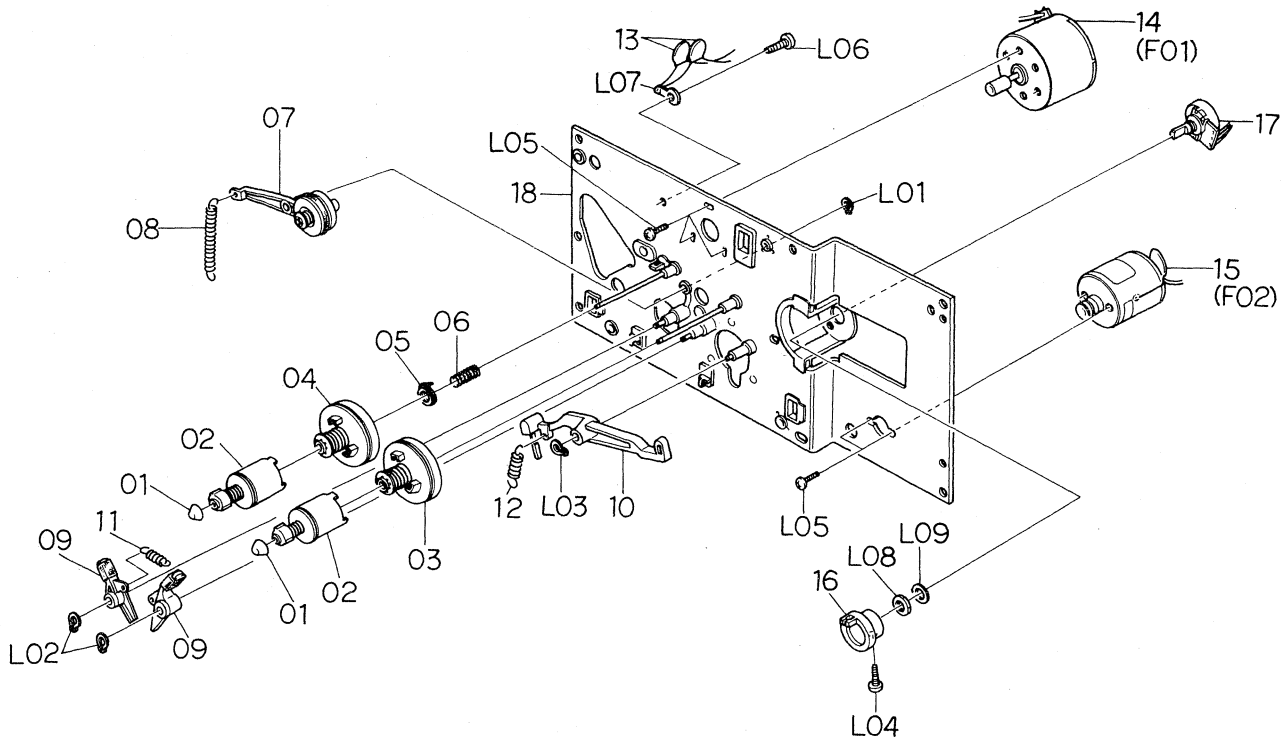

Fig. 9.9

Schematic Ref. No.	Part No.	Description	Q'ty
D02	CA08132A	Sub Mechanism Chassis Ass'y	1
01	0C08039A	Reel Hub Head	2
02	CA08038B	Reel Hub B Ass'y	2
03	CA08037A	Reel Hub Take-up Ass'y	1
04	CA08064A	Reel Hub Supply Ass'y	1
05	CA08039A	Back Tension Ass'y	1
06	0C08178A	Back Tension Spring A	1
07	CA08040A	Idler Ass'y	1
08	0C08127B	Idler Arm Spring	1
09	CA08042A	Brake Arm Ass'y	2
10	0C08030C	Brake Drive Arm	1
11	0C08129A	Brake Arm Spring	1
12	0C08128A	Brake Drive Arm Spring	1
13	0B09290A	Ceramic Capacitor 0.01 μ 50V	2
14	CA08117B	Reel Motor Ass'y	1
15	CA08034A	Control Motor Ass'y	1
16	0C08053B	Volume Coupler	1
17	0B07240A	Volume Control 10 k Ω (B)	1
18	CA08041A	Sub Chassis Ass'y	1
L01	0E00842A	Stopper Ring 2mm	1
L02	0E00837A	Stopper Ring 3mm	2
L03	0E00838A	Stopper Ring 4mm	1
L04	0E00859A	BT Screw M2.6x6 Philips Binding Head	1
L05	0E00226A	Screw M2.6x4 Philips Pan Head	5
L06	0E00843A	BT Screw M3x5 Philips Pan Head	1
L07	0E00037A	Earth Lug B-5	1
L08	-	Volume Nut	(1)
L09	-	Volume Washer	(1)

Schematic Ref. No.	Part No.	Description	Q'ty	Schematic Ref. No.	Part No.	Description	Q'ty
D03	CA08166A	Main Mechanism Chassis Ass'y	1	L04	0E00831A	BT Screw M3x10 Philips Pan Head	4
01	CA08048A	Cassette Case Holder L Ass'y	1	L05	0E00254A	Washer 3.1mm (Plastics)	2
02	CA08022A	Cassette Case Holder R Ass'y	1	L06	0E00222A	E-Ring 2mm	2
03	CA08066A	Cassette Case Ass'y	1	L07	0E00839A	Stopper Ring 2.5mm	2
04	0C08019I	Cover Plate	1	L08	0E00876A	BT Screw M2.6x8 Philips Pan Head	11
05	0M03977A	Cassette Viewer Label	1				
06	CA08131A	Head Mount Base Ass'y	1	L09	0C08060B	Height Adjustment Nut	2
07	0C08121A	Supply Pressure Roller Spring	2	L10	0E00142A	Washer 2.6mm	2
08	CA08053B	Supply Pressure Roller Ass'y	1	L11	0E00879A	BT Screw M2x15 Philips Pan Head	1
09	0C08122B	Supply Pressure Roller Thrust Spring	1	L12	0E00838A	Stopper Ring 4mm	3
10	CA08079B	Take-up Pressure Roller Ass'y	1	L13	0E00846A	BT Screw M3x8 Philips Pan Head	3
11	0C08183B	Take-up Pressure Roller Thrust Spring	1	L14	0E00895A	Earth Lug 3mm	2
12	0C08182A	Pressure Roller Drive Bar B	1				
13	CA08060A	Head Base Ass'y A	1				
14	0C08086B	Head Base Roller	3				
15	0C08050B	Record Sensor	1				
16	0C08051E	Cassette Hold Arm	1				
17	0C08120A	Cassette Hold Arm Spring	1				
18	CA08027A	Head Base Drive Arm Ass'y	1				
19	0C08143C	Head Base Drive Arm Spring	1				
20	CA08025A	Record Arm Ass'y	1				
21	0C08038D	Record Trigger	1				
22	0C08112A	Flip-Flop Spring	1				
23	CA08026A	Pressure Roller Drive Arm Ass'y	1				
24	0C08071D	Counter Reset Arm	1				
25	0C08124B	Eject Linkage Wire	1				
26	0C08057E	Eject Arm	1				
27	0C08078B	Arm Shaft	1				
28	CA08032B	Auto Shut-off Ass'y	1				
29	0C08097B	Counter Belt A	1				
30	CA08020A	Counter Ass'y	1				
31	0C08098B	Counter Belt B	1				
32	0C08067C	Eject Stopper	1				
33	0C08134C	Eject Stopper Spring	1				
34	0C08119A	Record Protector	1				
35	0C08194C	Damper Lock Arm	1				
36	0C08153A	Damper Arm Spring Tube	1				
37	0C08125A	Damper Arm Spring	1				
38	0C08151A	Lid Arm Spring Tube	1				
39	0C08114A	Lid Arm Spring	1				
40	CA08030A	Pneumatic Damper Ass'y	1				
41	CA08023A	Supply Capstan Flange Ass'y	1				
42	CA08024A	Take-up Capstan Flange Ass'y	1				
43	0C08186A	Cam Drive Gear	1				
44	0C08029H	Control Cam	1				
45	0C08117A	Counter-Load Arm Spring	1				
46	0C08152A	Counter-Load Arm Spring Tube	1				
47	CA08028A	Counter-Load Arm Ass'y	1				
48	0C08123B	Record Switch Linkage Wire	1				
49	0C08037E	Record Arm B	1				
50	0C08116A	Record Arm Spring	1				
51	CA08072A	Main Chassis Ass'y	1				
52	0B08626D	6P-H Connector	1				
53	0C08225A	Shield Plate	1				
L01	0E00837A	Stopper Ring 3mm	13				
L02	0E00832A	BT Screw M3x14 Philips Pan Head	2				
L03	0E00834A	BT Screw M3x30 Philips Pan Head	2				

9.10. Main Mechanism Chassis Ass'y (D03)

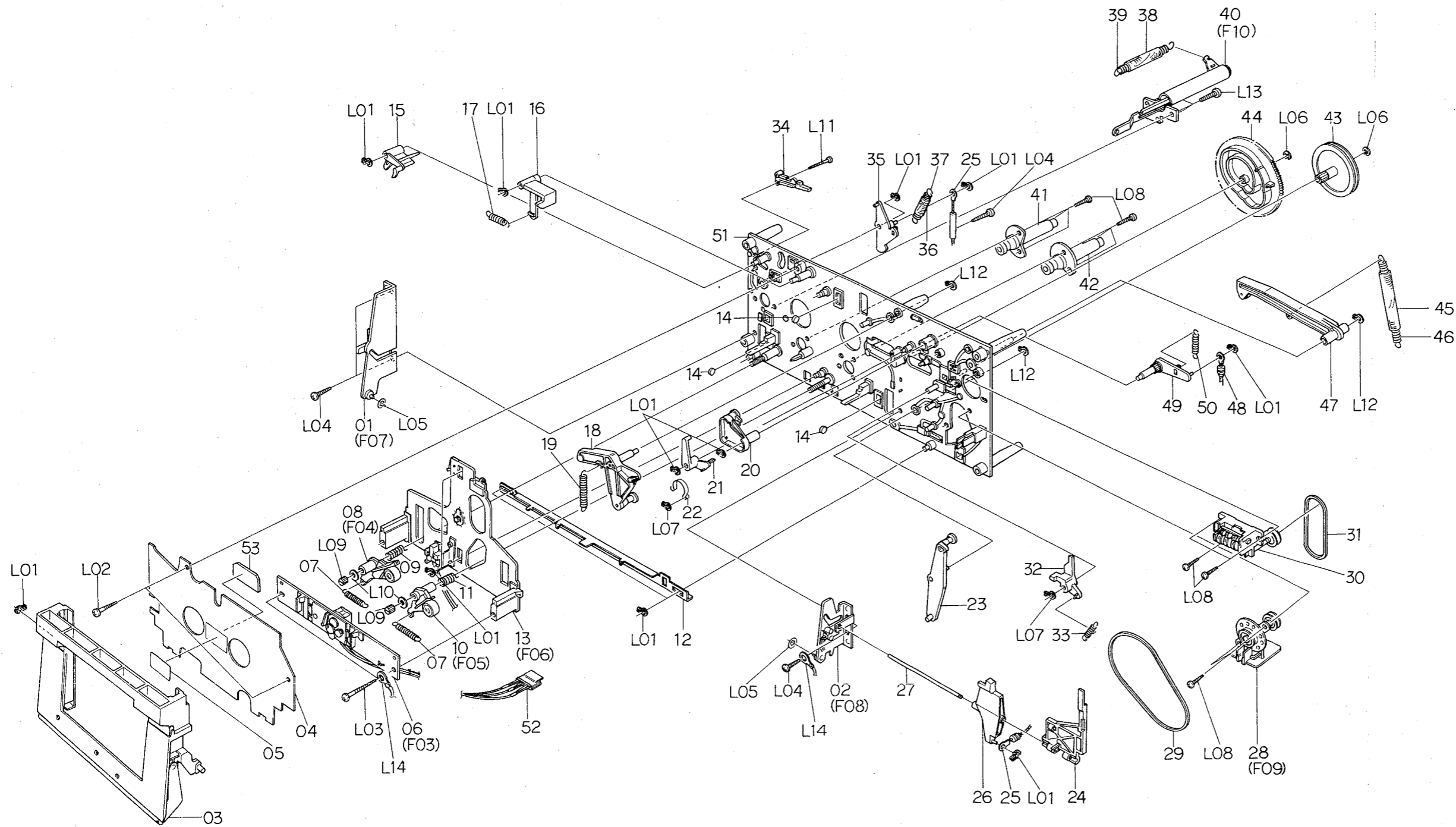

Fig. 9.10

9.11. Rear Panel Ass'y (E01)

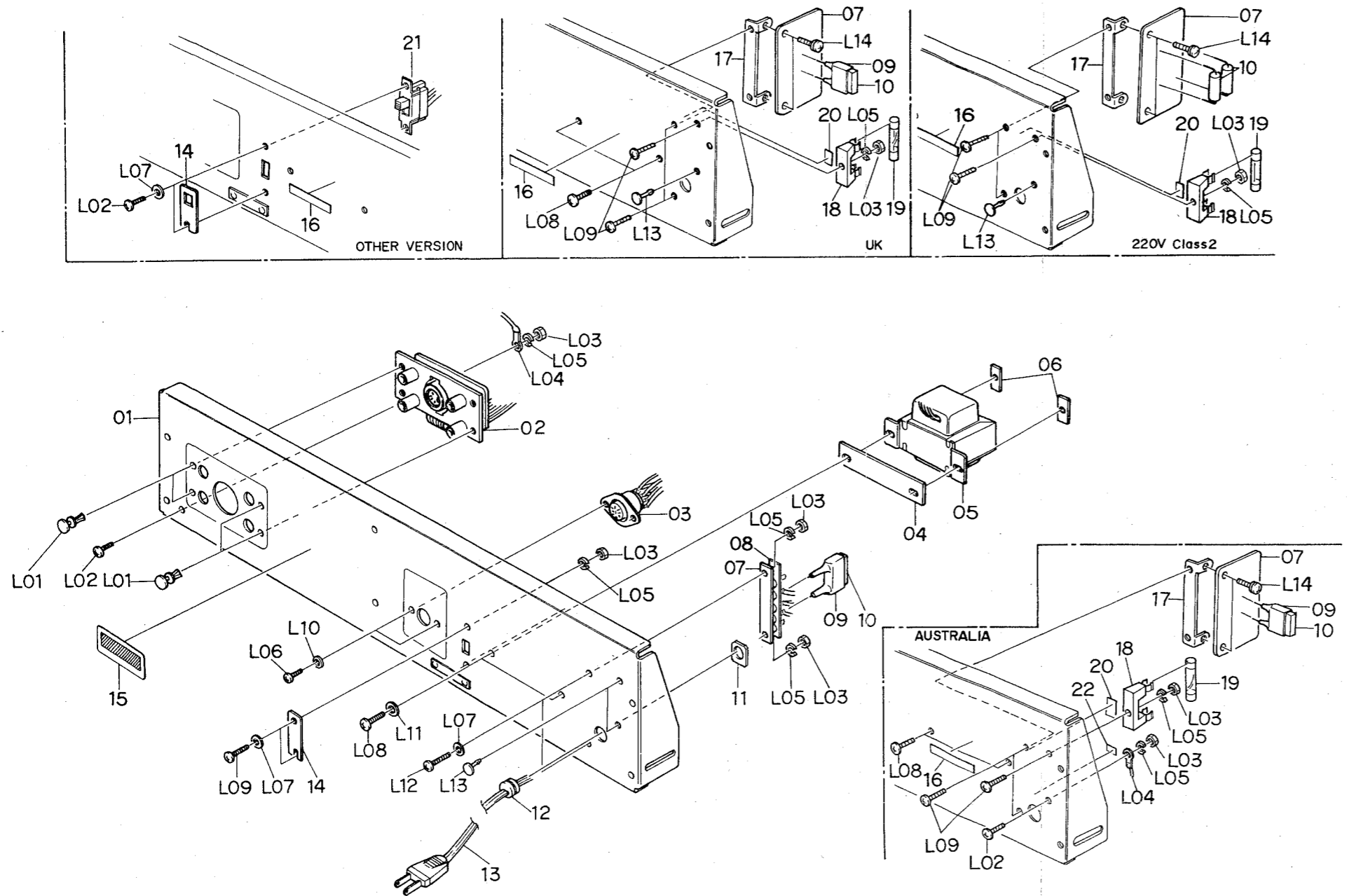

Fig. 9.11

Schematic Ref. No.	Part No.	Description	Q'ty
E01	JA03537A	Rear Panel Ass'y (U.S.A. & Canada)	1
	JA03538A	Rear Panel Ass'y (Japan)	1
	JA03539A	Rear Panel Ass'y (Others)	1
	JA03540A	Rear Panel Ass'y (220V Class 2)	1
	JA03541A	Rear Panel Ass'y (UK)	1
	JA03619A	Rear Panel Ass'y (Australia)	1
01	OJ04023A	Rear Panel	1
02	BA03973A	DIN-Pin P.C.B. Ass'y	1
03	OB08584A	8P DIN Socket	1
04	OJ04016A	Transformer Plate	1
05	OB06593A	Power Transformer (U.S.A. & Canada)	1
	OB06603A	Power Transformer (Japan)	1
	OB06594A	Power Transformer (220V Class 2, UK & Australia)	1
	OB06595A	Power Transformer (Others)	1
06	OC01162B	Bolt Receptacle Plate	2
07	OB08025U	5P Terminal Strip (U.S.A., Canada, Japan & Others)	1
	OB07817B	Terminal P.C.B. C (220V class 2, UK & Australia)	1
08	OB08555A	5P Terminal Insulator 08 (U.S.A. & Canada)	1
	OB08268U	5P Terminal Insulator 05 (Japan & Others)	1
09	OB08359A	Spark Killer Cover (U.S.A., Canada, Japan, Others, UK & Australia)	1
10	OB08363A	Spark Killer (Japan)	1
	OB08342A	Spark Killer (U.S.A. & Canada)	1
	OB08240U	Spark Killer (UK, Australia & Others)	1
	OB08445A	Spark Killer (220V Class 2)	2
11	OA03154B	Cord Spacer	1
12	OB08037U	Cord Bushing C (U.S.A., Canada, Japan, 220V Class 2 & Others)	1
	OB08351A	Cord Bushing 4K-4 (UK)	1
	OB08325U	Cord Bushing E (Australia)	1
13	OB08533A	Power Cord (U.S.A., Canada & Others)	1
	OB08219B	Power Cord (Japan)	1
	OB08093U	Power Cord (220V Class 2)	1
	OB08348A	Power Cord (UK)	1
	OB08666A	Power Cord (Australia)	1
14	OJ03663C	Switch Cover	1
	OM03946A	Voltage Selector Lock Plate C (Others)	1
15	OM03458B	Pass Label	1
16	OM03794A	Voltage Label 100V (Japan)	1
	OM03796A	Voltage Label 220V (220V Class 2)	1
	OM03797A	Voltage Label 240V (UK & Australia)	1
	OM03955A	Voltage Label 120V, 220-240V (Others)	1
17	OJ03893A	Terminal P.C.B. Holder B (220V Class 2, UK & Australia)	1
18	OB08048U	Fuse Holder (UK & Australia)	1
19	OB08344A	Fuse 200mA T 250V (220V Class 2, UK & Australia)	1

Schematic Ref. No.	Part No.	Description	Q'ty
20	0M03968A	Fuse Label 200mA T (220V Class 2, UK & Australia)	1
21	0B07092U	Voltage Selector (Others)	1
22	0M03700A	Earth Mark Label (Australia)	1
-	0M03844B	Power Cord Label (UK)	1
-	0M04058A	Serial Number Plate	1
-	0M03697A	Rating Label (220V Class 2)	1
-	0M03798A	Nakamichi Label (Japan)	1
L01	0B08539A	Plastic Rivet	4
L02	0E00593A	Screw M3x6 Philips Binding Head (Bronze)	4
L03	0E00507A	Nut Hex. M3	7
L04	0E00037A	Earth Lug B-5	2
L05	0E00581A	Washer 3mm Spring	7
L06	0E00714A	Screw M2.6x6 Philips Binding Head (Bronze)	2
L07	0E00157A	Washer 3mm (Black Plastics)	4
L08	0E00756A	Screw M4x8 Philips Binding Head (Bronze)	2
L09	0E00594A	Screw M3x8 Philips Binding Head (Bronze)	5
L10	0E00651A	Washer 2.6mm (Black Plastics)	2
L11	0E00645A	Washer 4mm (Black Plastics)	2
L12	0E00701A	Screw M3x10 Philips Binding Head (Bronze)	2
L13	0B08583A	Plastic Clip	2
L14	0E00510A	Screw M3x8 Philips Pan Head (2A)	2
-	0J03644A	Chobert Rivet	2
F01	CA08117B	Reel Motor Ass'y	1
01	0C08218A	Reel Motor	1
02	0C08063F	Reel Motor Pulley	1
F02	CA08034A	Control Motor Ass'y	1
01	0C08137A	Control Motor	1
02	0C08064A	Control Motor Pulley	1
03	0B09292A	Ceramic Capacitor 0.1μ 50V	1
04	0M03985A	Control Motor Label	1
05	0M03988A	Motor Seal B	1
F03	CA08131A	Head Mount Base Ass'y	1
01	0C08028C	Head Height Adjustment Gear	1
02	0C08027E	Head Height Adjustment Screw	2
03	0C08026D	Azimuth Alignment Screw	1
04	0C08161B	Spring Stopper	1
05	0C08187B	Head Plate Spring	1
06	CA08083C	Head Mount Base Sub Ass'y	1
07	CA08143A	RP-9E Record/Playback Head Ass'y	1

9.12. Reel Motor Ass'y (F01)

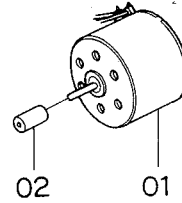

Fig. 9.12

9.13. Control Motor Ass'y (F02)

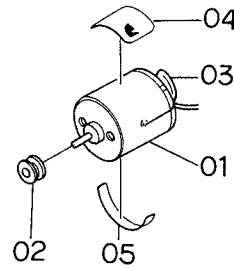

Fig. 9.13

9.14. Head Mount Base Ass'y (F03)

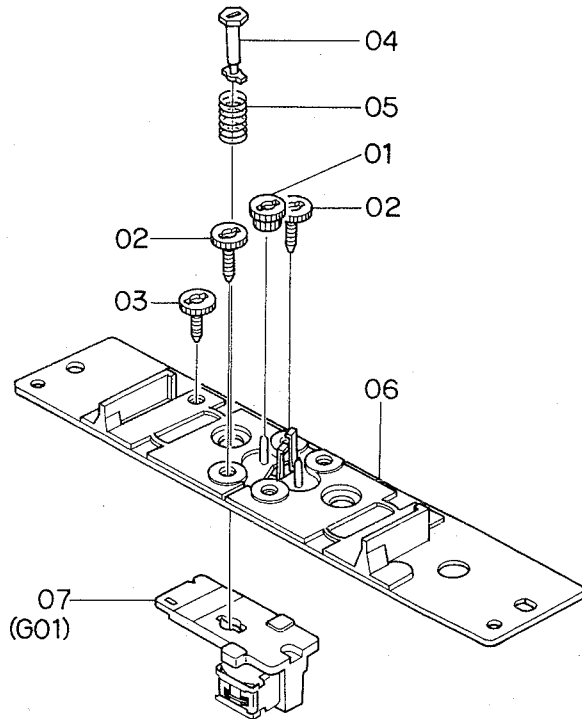

Fig. 9.14

9.15. Supply Pressure Roller Ass'y (F04)

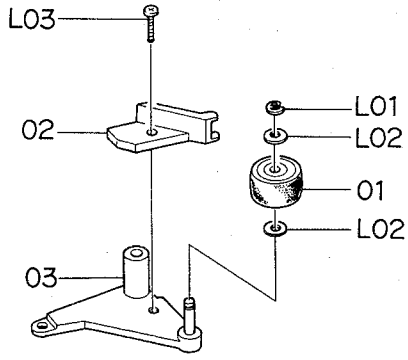

Fig. 9.15

9.16. Take-up Pressure Roller Ass'y (F05)

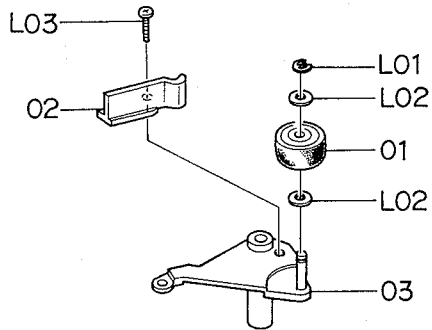

Fig. 9.16

9.17. Head Base Ass'y A (F06)

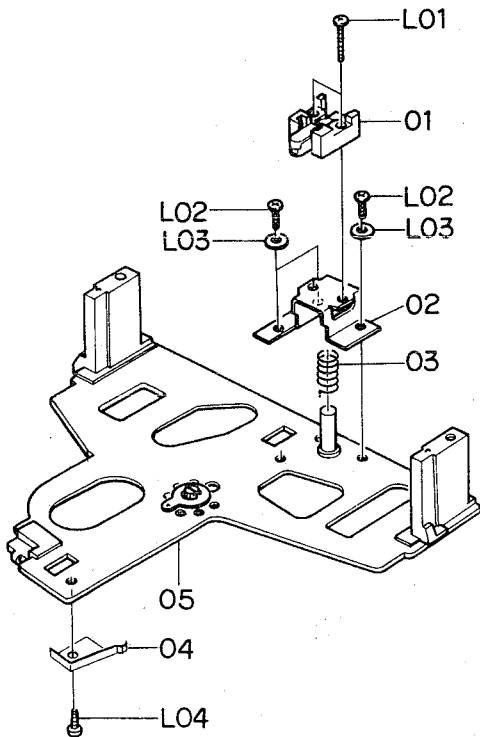

Fig. 9.17

9.18. Cassette Case Holder L Ass'y (F07)

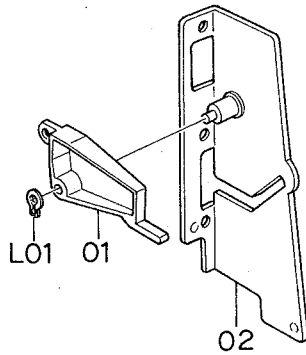

Fig. 9.18

9.19. Cassette Case Holder R Ass'y (F08)

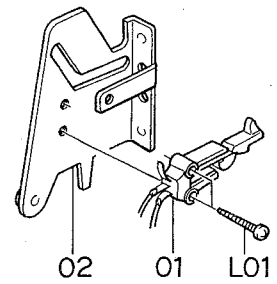

Fig. 9.19

9.20. Auto Shut-off Ass'y (F09)

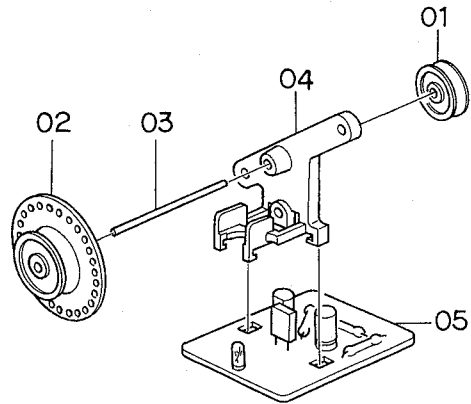

Fig. 9.20

9.21. Pneumatic Damper Ass'y (F10)

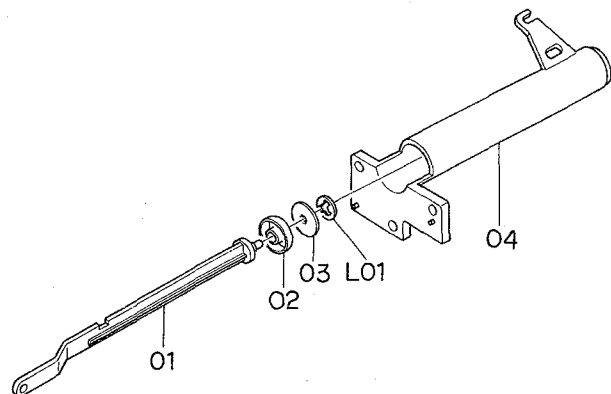

Fig. 9.21

9.22. RP-9E Record/Playback Head Ass'y (G01)

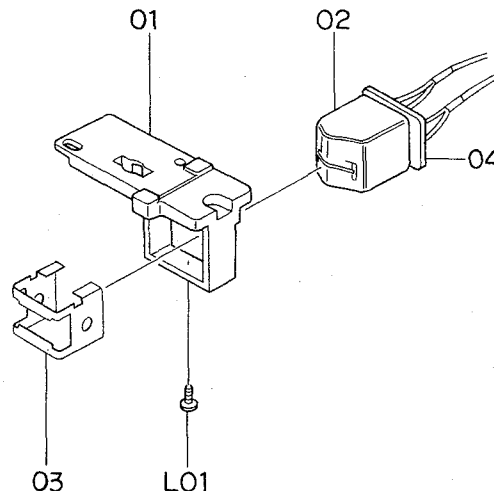

Fig. 9.22

Schematic Ref. No.	Part No.	Description	Q'ty	Schematic Ref. No.	Part No.	Description	Q'ty
F04	CA08053B	Supply Pressure Roller Ass'y	1	F08	CA08022A	Cassette Case Holder R Ass'y	1
01	0C08164E	Pressure Roller	1	01	0C08133A	Eject Sensor	1
02	0C08189B	Supply Tape Guide	1	02	CA08044A	Cassette Case Holder R Sub Ass'y	1
03	CA08061A	Supply Pressure Roller Arm Ass'y	1	L01	0E00840A	BT Screw M2x8 Philips Pan Head	2
L01	0E00042A	E-Ring 1.5mm	1	F09	CA08032B	Auto Shut-off Ass'y	1
L02	0C08024A	Washer 2mm	2	01	0C08206B	Shut-off Pulley B	1
L03	0E00788A	BT Screw M2x8 Philips Pan Head	1	02	0C08047A	Shut-off Pulley A	1
F05	CA08079A	Take-up Pressure Roller Ass'y	1	03	0C08088B	Shut-off Pulley Shaft	1
01	0C08164E	Pressure Roller	1	04	0C08207B	Shut-off Pulley Holder	1
02	0C08181B	Take-up Tape Guide	1	05	BA04076A	Shut-off P.C.B. Ass'y	1
03	CA08073B	Take-up Pressure Roller Arm Ass'y	1	F10	CA08030A	Pneumatic Damper Ass'y	1
L01	0E00042A	E-Ring 1.5mm	1	01	0C08058C	Damper Piston	1
L02	0C08024A	Washer 2mm	2	02	0C08102B	Damper Ring	1
L03	0E00788A	BT Screw M2x8 Philips Pan Head	1	03	0C08010C	Damper Plate	1
F06	CA08060A	Head Base Ass'y A	1	04	0C08059E	Sylinder	1
01	GA02017A	Erase Head E-8L	1	L01	0E00874A	Stopper Ring CS 2mm	1
02	0C08158C	EH Hold Plate	1	G01	CA08143A	RP-9E Record/Playback Head Ass'y	1
03	0C08166A	EH Hold Plate Spring	1	01	0C08217A	Head Plate	1
04	0C08174C	Cassette Hold Spring	1	02	0G01294A	RP-9E Record/Playback Head	1
05	CA08003P	Head Base Ass'y	1	03	0C08216B	Pad Lifter 9E	1
L01	0E00889A	Screw M1.7x8 Philips Pan Head	2	04	0B07857A	Head P.C.B.	1
L02	0E00909A	Screw M2x6 Philips Pan Head (Black Chromate)	3	L01	0E00887A	Screw M1.7x4 Philips Pan Head	1
L03	0E00117A	Washer 2mm	3				
L04	0E00853A	BT Screw M2x3 Philips Pan Head	1				
F07	CA08048A	Cassette Case Holder L Ass'y	1				
01	0C08073C	Lid Arm A	1				
02	CA08035A	Cassette Case Holder L Sub Ass'y	1				
L01	0E00837A	Stopper Ring 3mm	1				

10. EQ. AMP. FREQUENCY RESPONSE

10.1. Playback Frequency Response

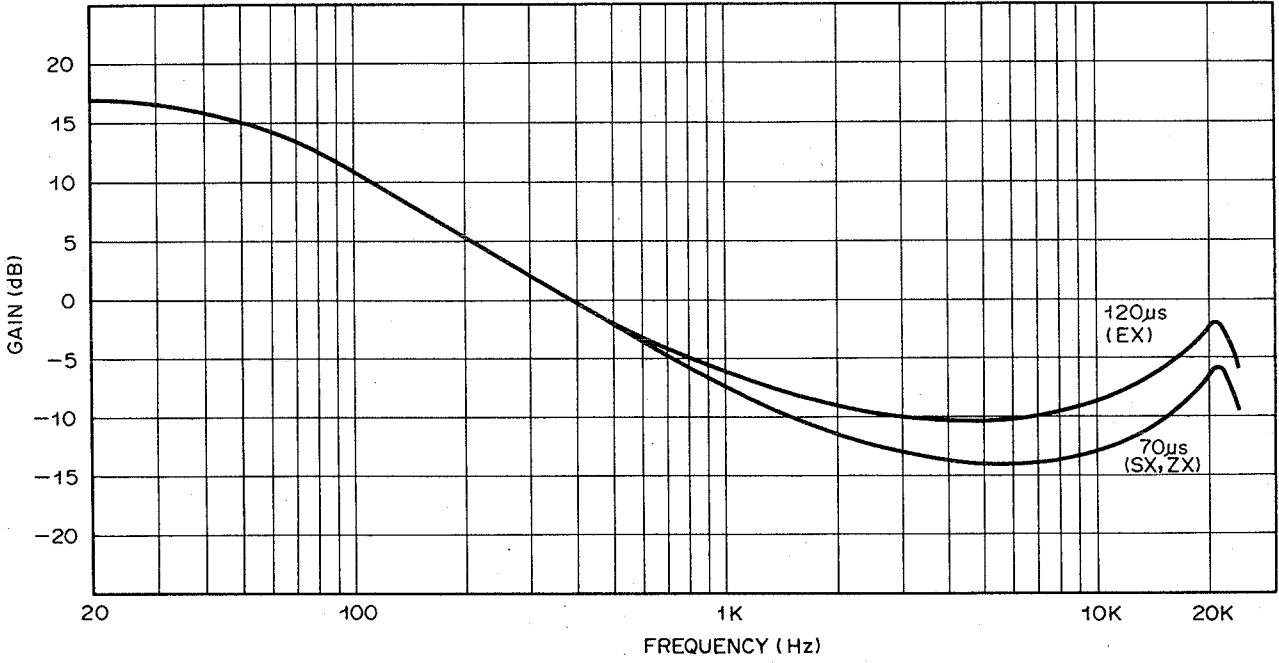

Fig. 10.1

10.2. Record Current Frequency Response

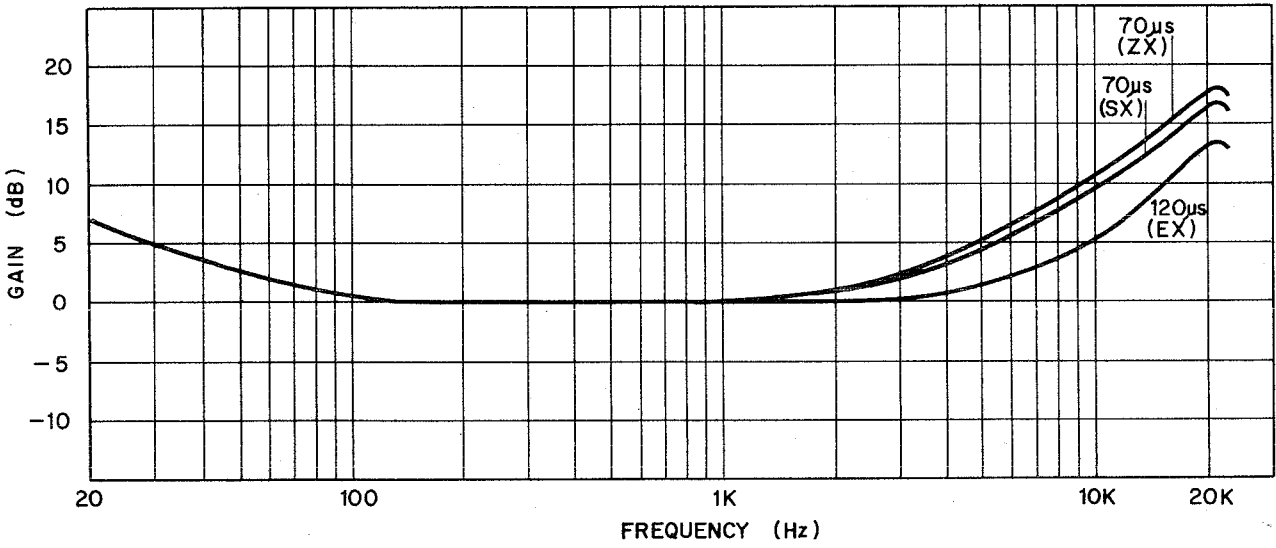

Fig. 10.2

11. OVERALL TIMING CHART

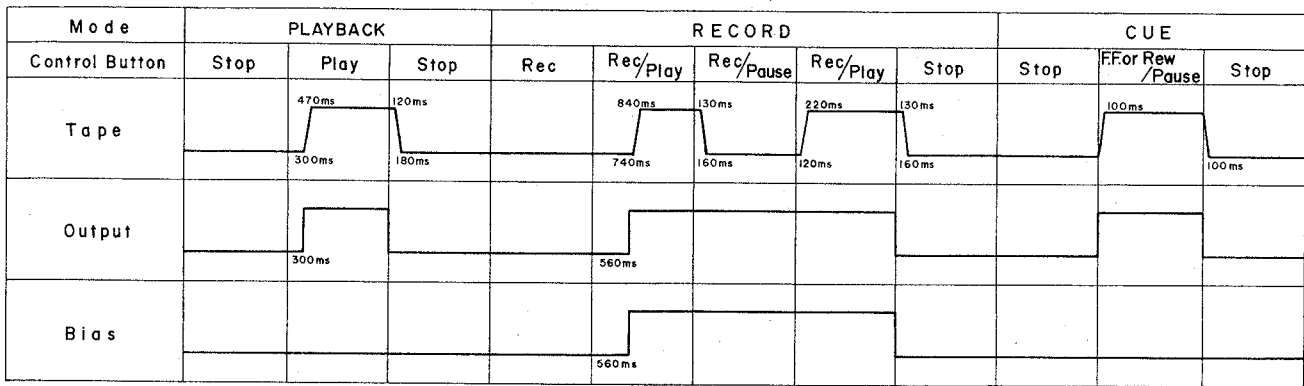

Fig. 11

12. WIRING DIAGRAM

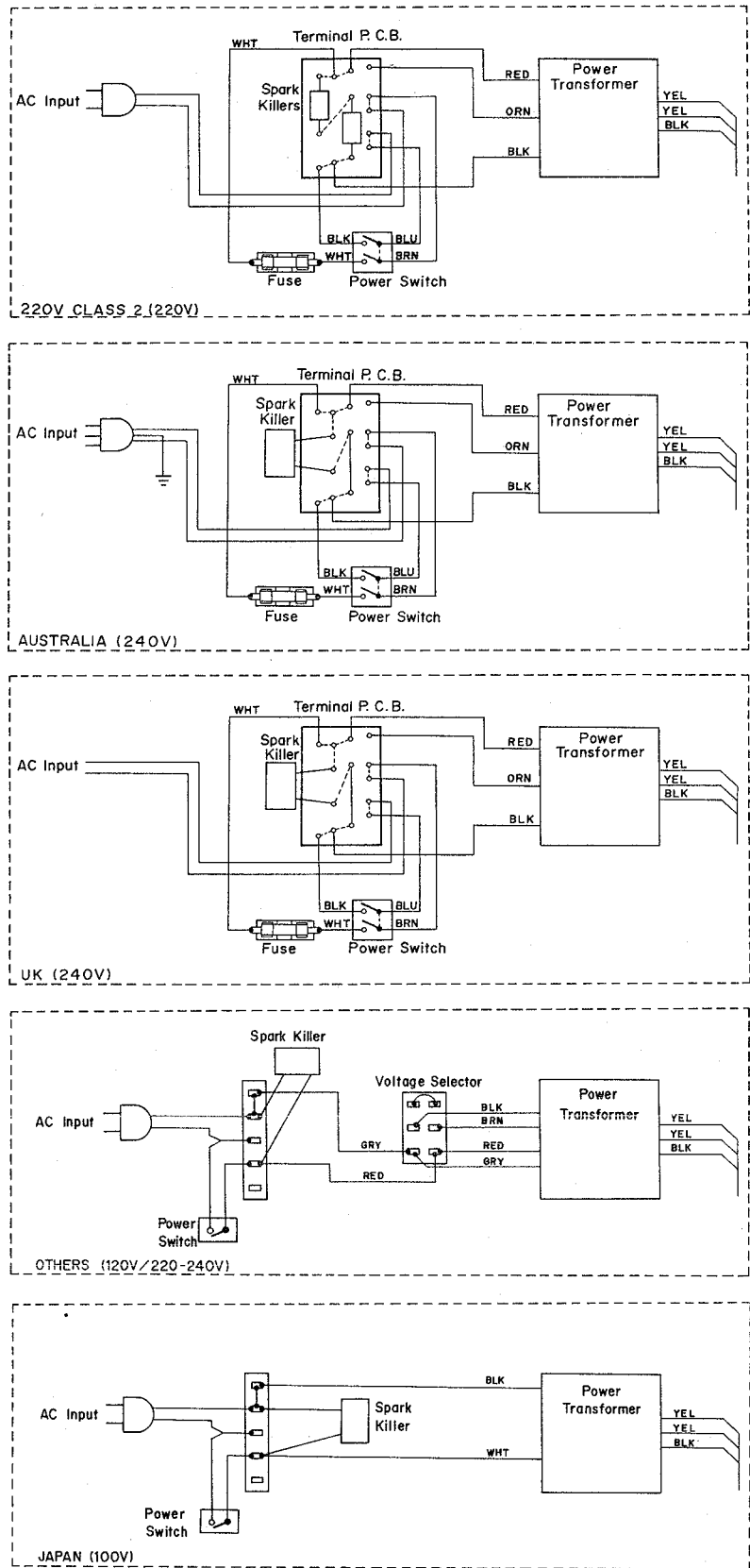
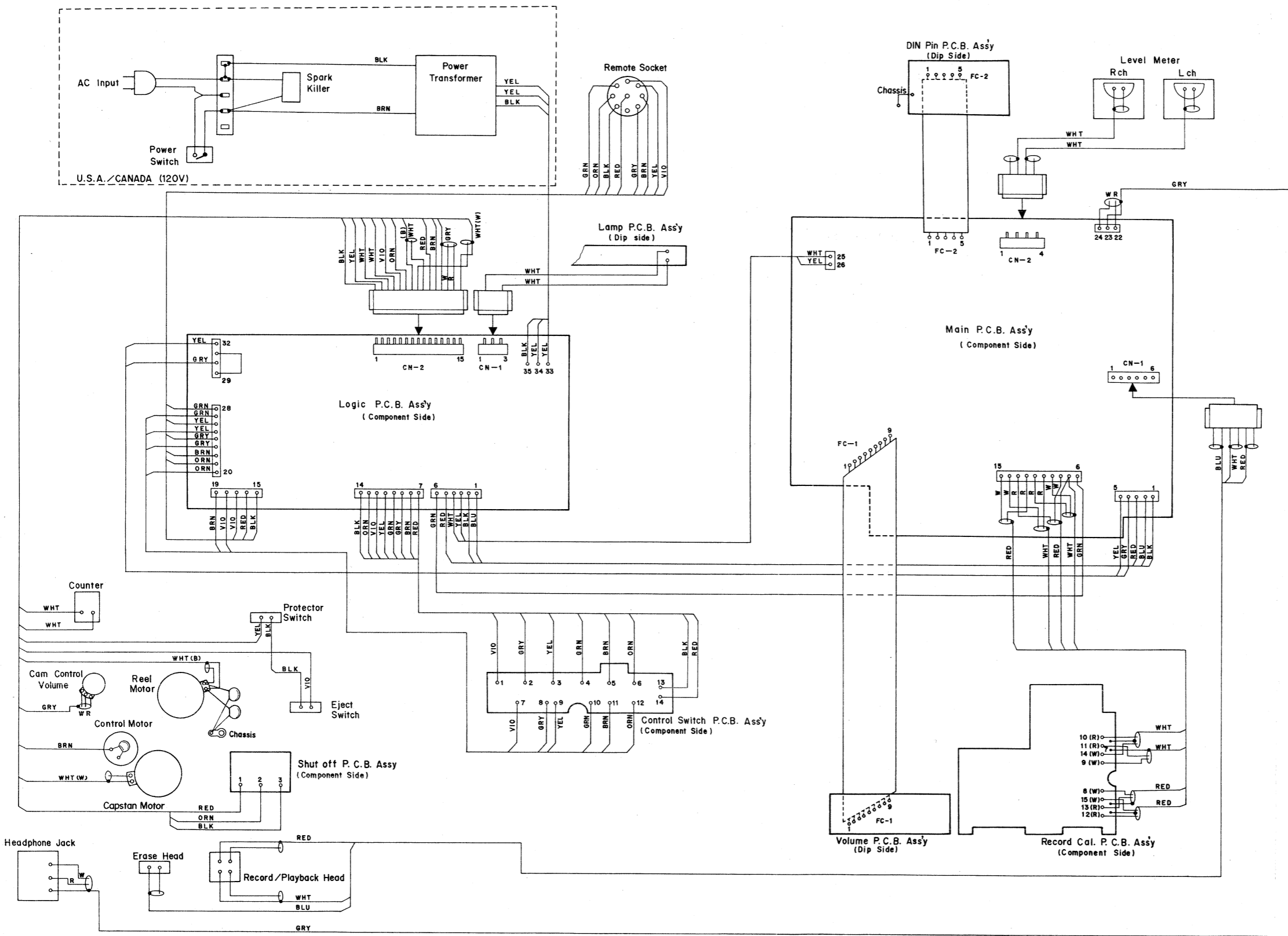

Fig. 12.1



Note: Table of wire colors

BLK — Black	GRY — Gray	BRN — Brown	VIO — Violet
BLU — Blue	GRN — Green	YEL — Yellow	
ORN — Orange	RED — Red	WHT — White	

Fig. 12.2

13. BLOCK DIAGRAMS

13.1. Amplifier

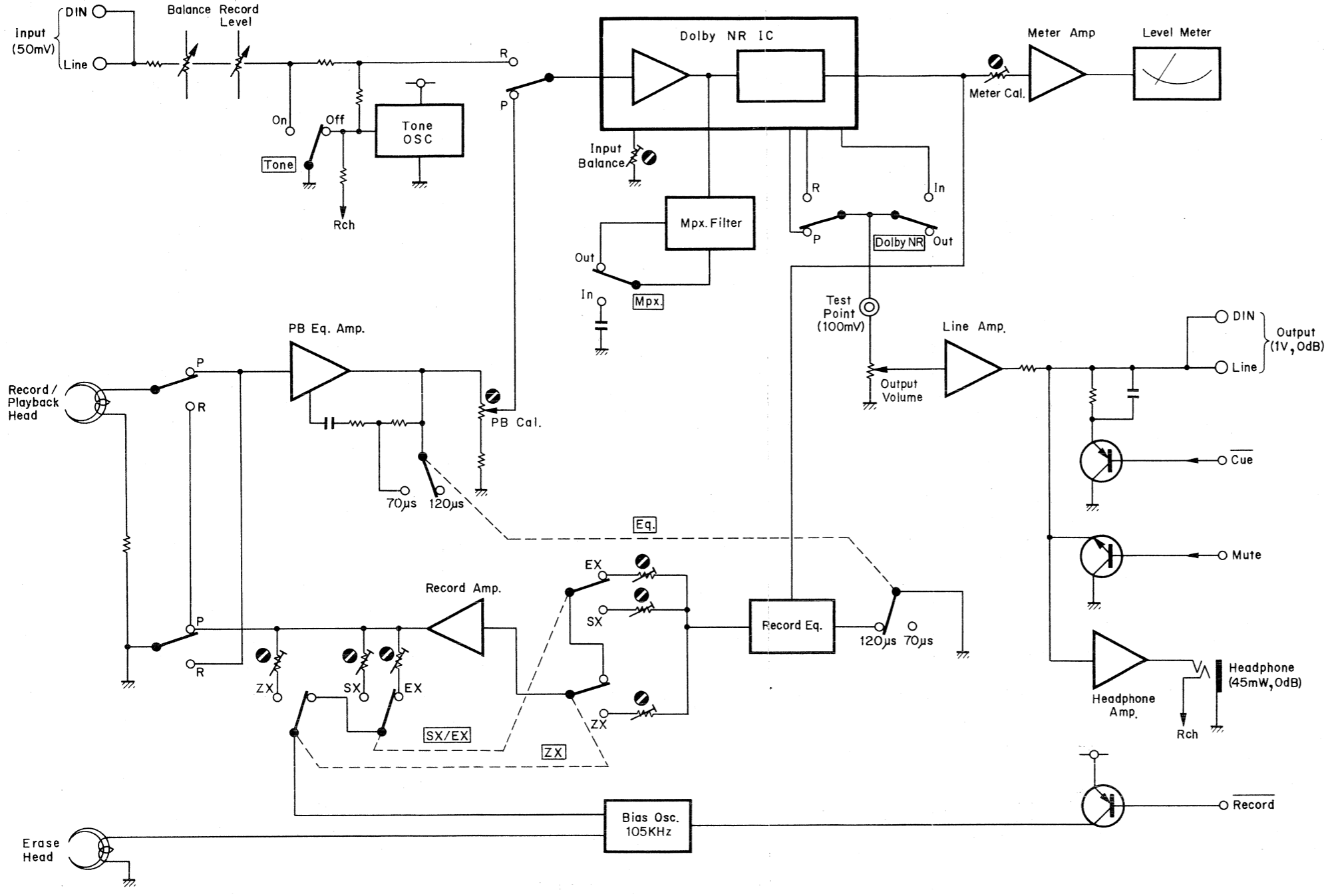

Fig. 13.1

13.2. Mechanism Control

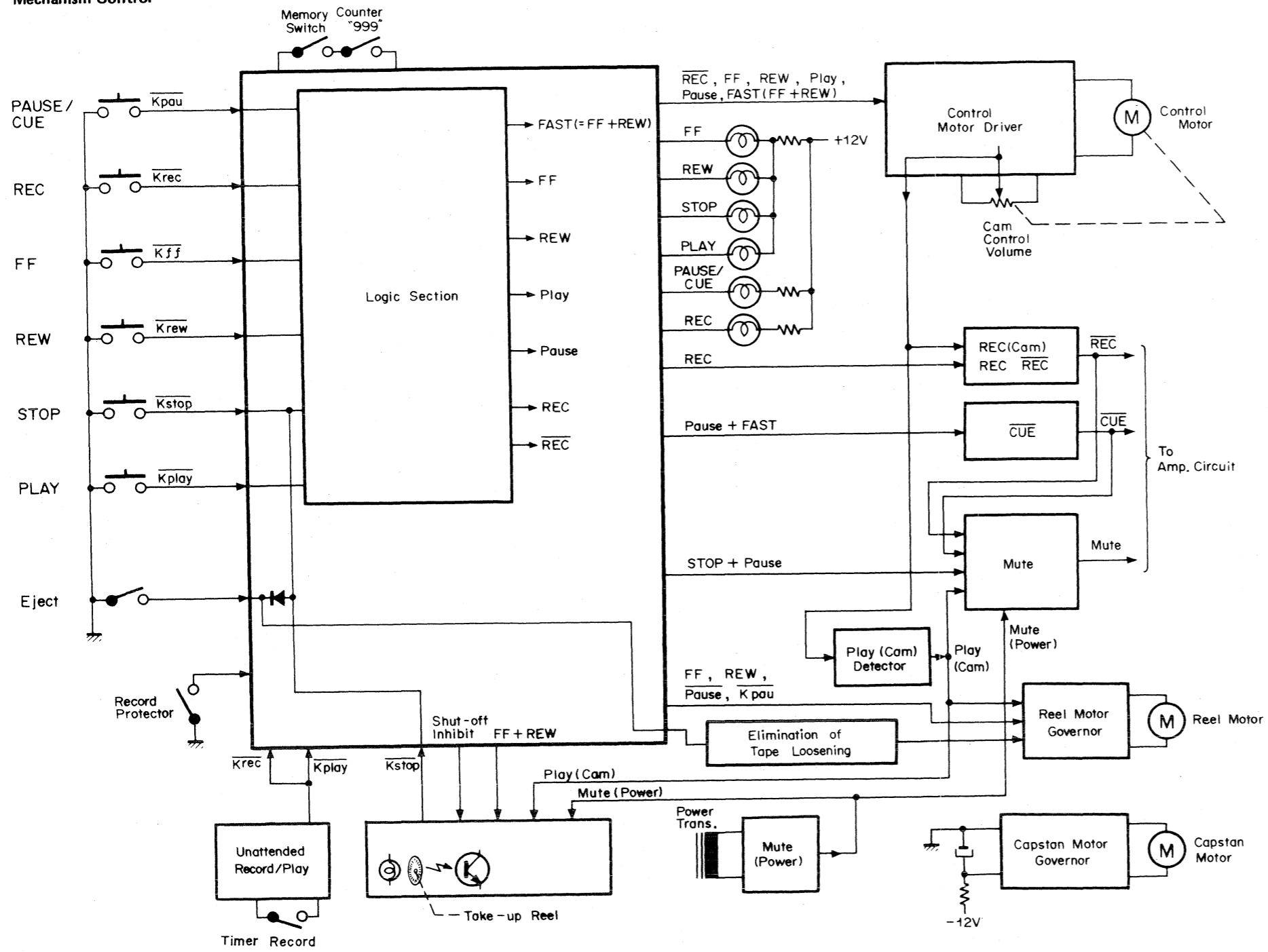
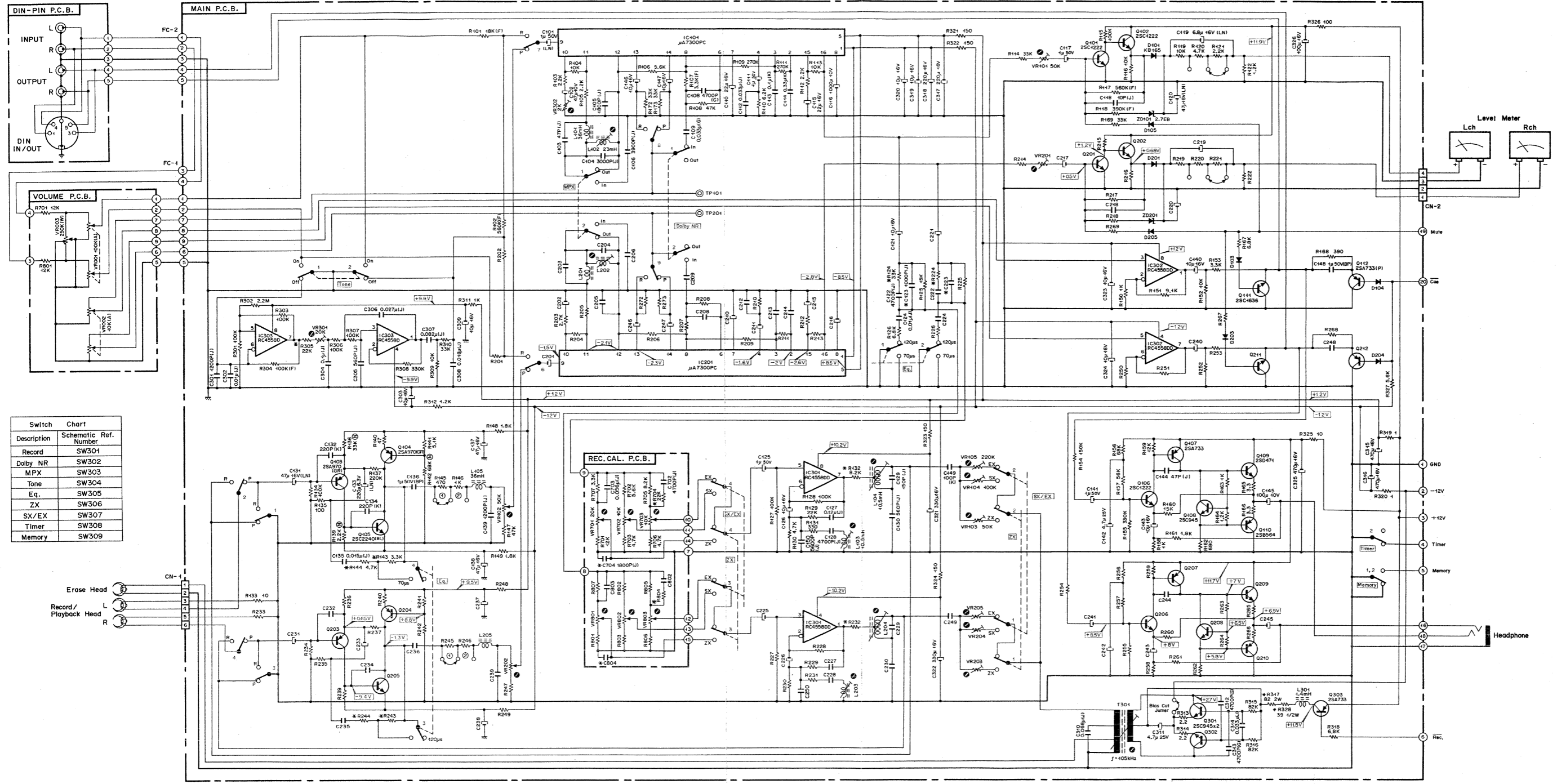

Fig. 13.2

14. SCHEMATIC DIAGRAMS

Note: Refer to diagrams of ICs on page 76.

14.1. Amplifier



Description	Schematic Ref. Number
Record	SW301
Dolby NR	SW302
MPX	SW303
Tone	SW304
Eq.	SW305
ZX	SW306
SX/EX	SW307
Timer	SW308
Memory	SW309

Fig. 14.1

Notes: 1. Diode is 1SS53, 1S953, or 1S1555 unless otherwise specified.
 2. Resistor and capacitor marked with * show typical value.

14.2. Mechanism Control

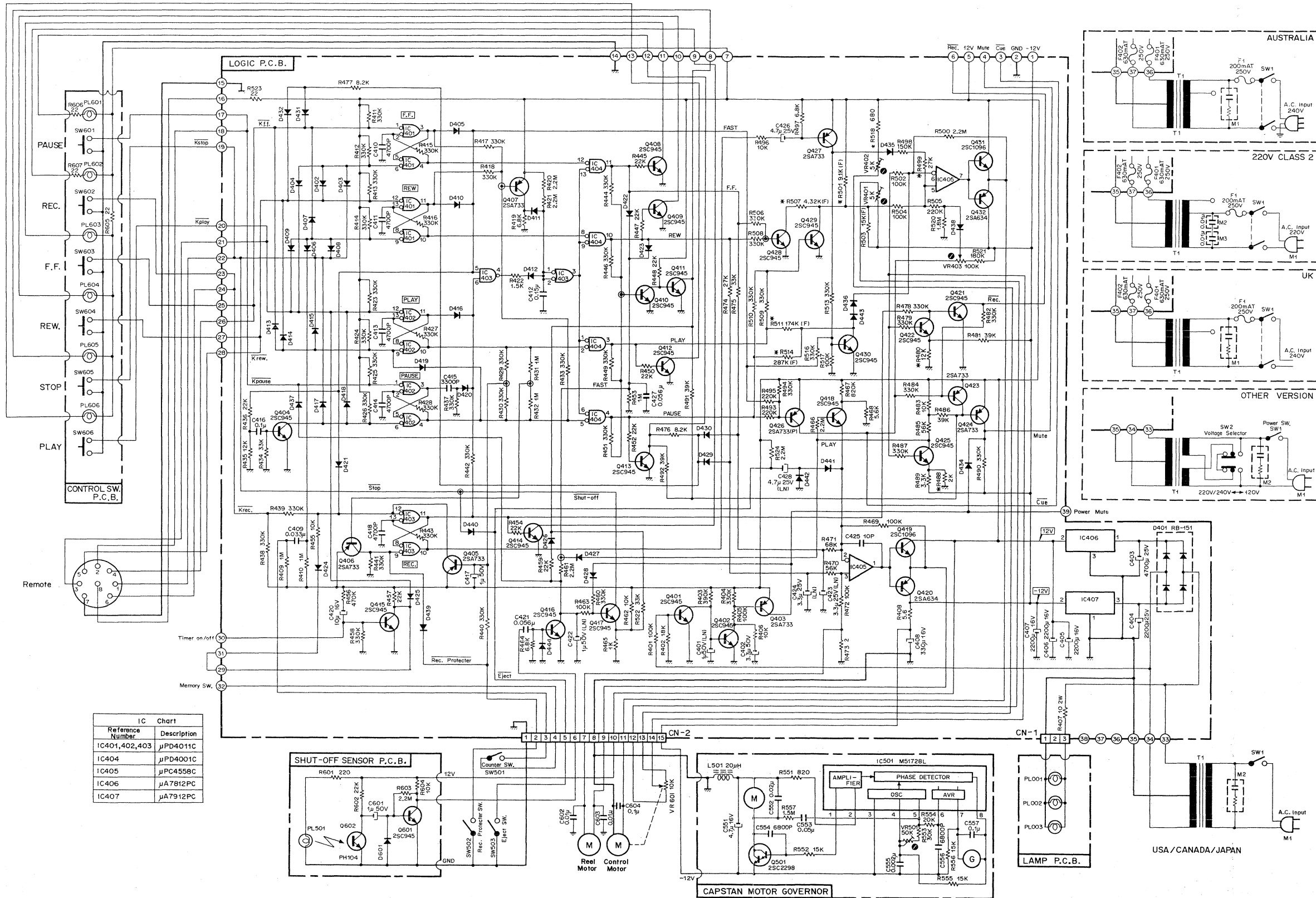

Reference Number	IC Chart Description
IC401,402,403	μPD4011C
IC404	μPD4001C
IC405	μPC4558C
IC406	μA7812PC
IC407	μA7912PC

Fig. 14.2.1
Serial No.: A30302310 -

Notes: 1. Diode is 1SS53, 1S953, or 1S1555 unless otherwise specified.
2. Resistor marked with * shows typical value.

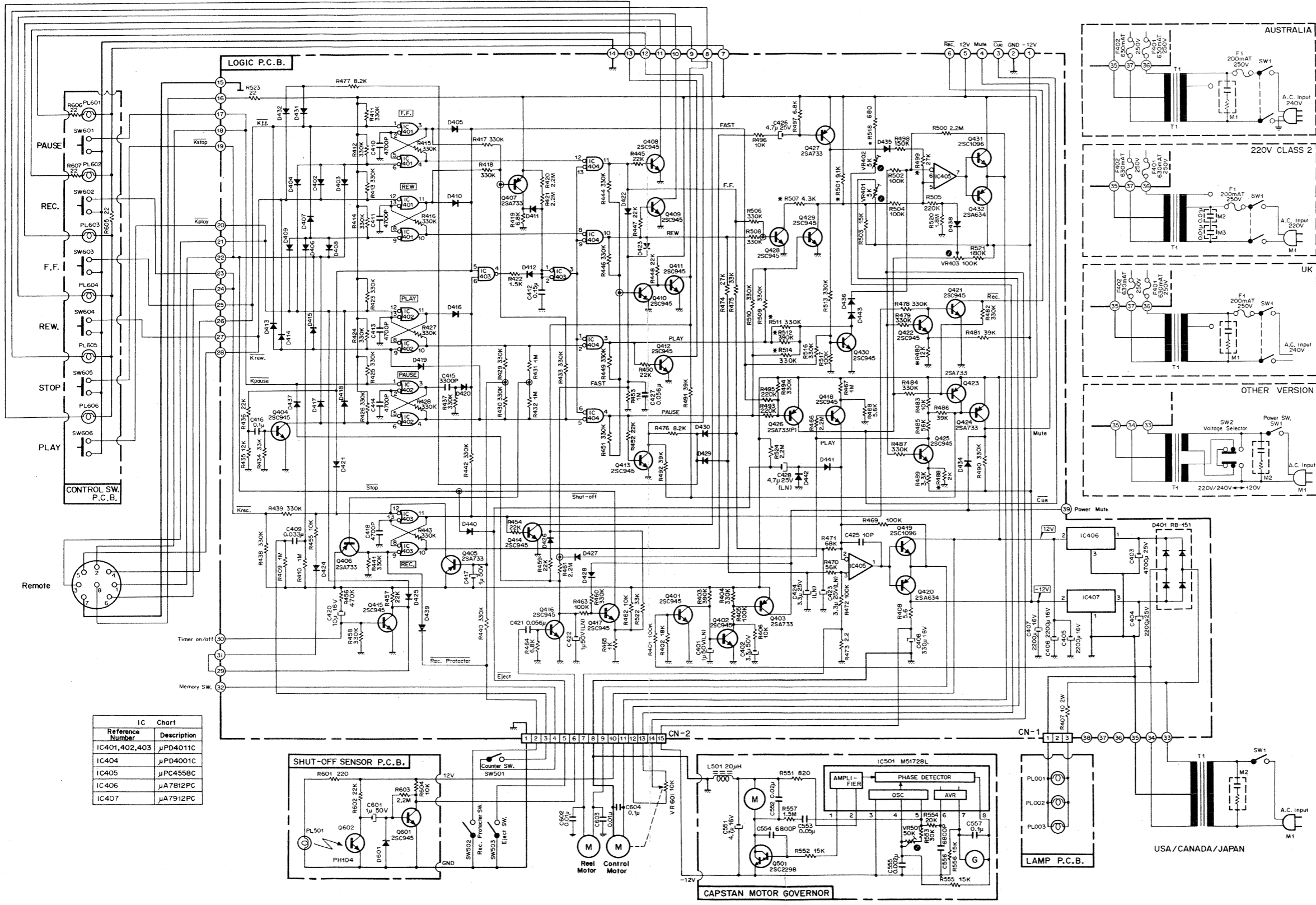

IC Chart	
Reference Number	Description
IC401,402,403	μPD4011C
IC404	μPD4001C
IC405	μPC4558C
IC406	μA7812PC
IC407	μA7912PC

Fig. 14.2.2
Serial Nos.: A30301001 – A30302309

Notes: 1. Diode is 1S53, 1S953, or 1S1555 unless otherwise specified.
2. Resistor marked with * shows typical value.

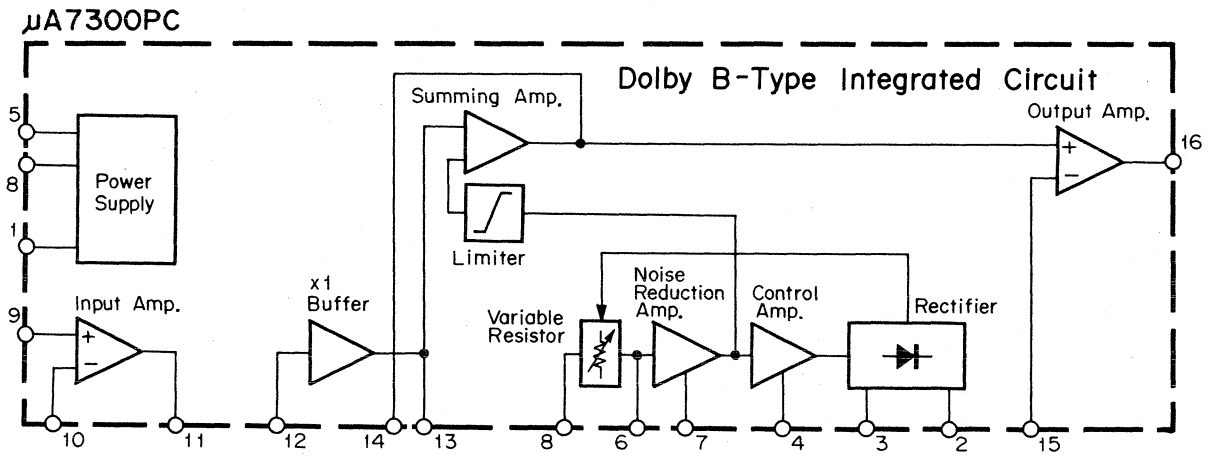

Fig. 14.3 Dolby NR IC μ A7300PC

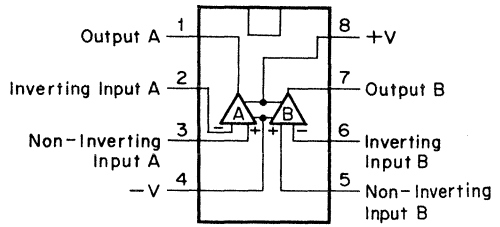
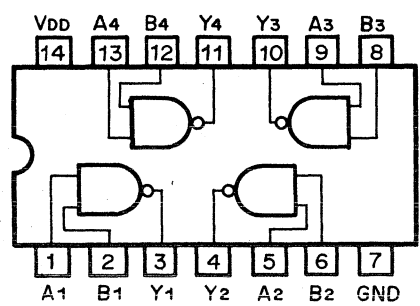
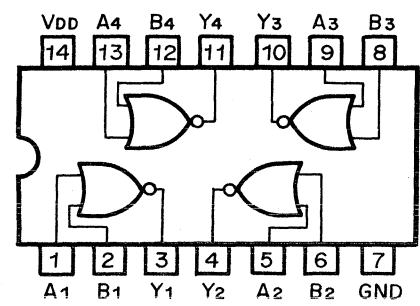

Fig. 14.4 Operational Amp. IC 4558



(TOP VIEW)
Fig. 14.5 C-MOS IC μ PD4011C



(TOP VIEW)
Fig. 14.6 C-MOS IC μ PD4001C

15. REMOTE CONTROL UNIT RM-580 (OPTIONAL)

Refer to item 2.4, principle of operation of RM-580.

15.1. Mounting Diagrams

Note: Mounting diagram shows a dip side view of the printed circuit board.

15.1.1. Receiver

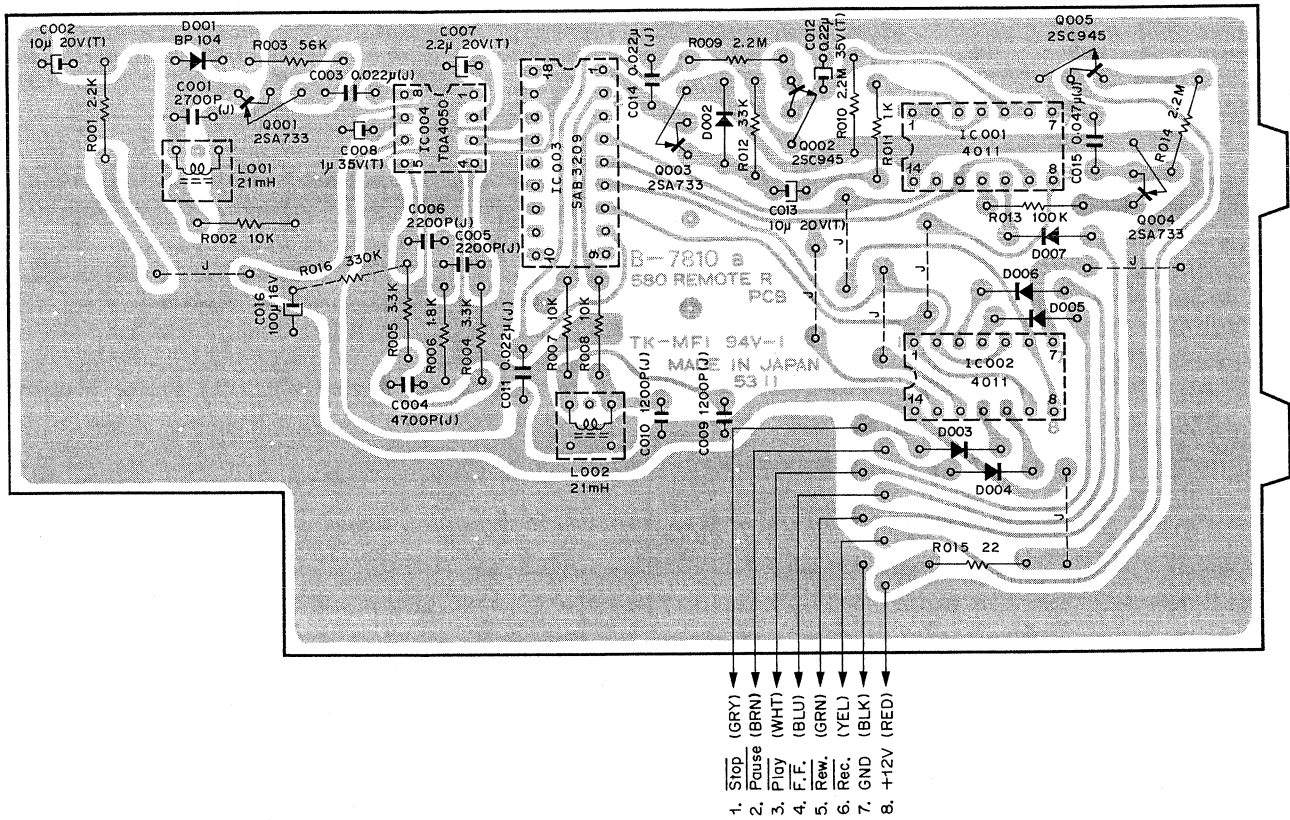

Fig. 15.1.1

Schematic Ref. No.	Part No.	Description	Schematic Ref. No.	Part No.	Description
	BA04002A	Remote Receiver P.C.B. Ass'y	R011	0B01857A	Carbon Resistor 1K ERD-25T J
	0B07810B	Remote Receiver P.C.B.	R012	0B05509A	Carbon Resistor 33K ERD-25T J
IC001,002	0B06178A	IC μ PD4011C	R013	0B01889A	Carbon Resistor 100K ERD-25T J
IC003	0B06162A	IC SAB3209	R015	0B05579A	Carbon Resistor 22 ERD-25T J
IC004	0B06163A	IC TDA4050	R016	0B05627A	Carbon Resistor 330K ERD-25T J
Q001,003	0B06013A	Transistor 2SA733	C001	0B09231A	SP Capacitor 2700P 50V J
Q004			C002,013	0B05581A	Tantalum Capacitor 10 μ 20V
Q002,005	0B06100A	Transistor 2SC945	C003,011	0B09291A	Ceramic Capacitor 0.022 μ 50V J
D001	0B06165A	Photo Diode BP104	014		
D002,003	0B01909A	Silicon Diode 1S1555	C004	0B05652A	Mylar Capacitor 4700P 50V J
004,005			C005,006	0B01802A	Mylar Capacitor 2200P 50V J
006,007			C007	0B05598A	Tantalum Capacitor 2.2 μ 20V
L001,002	0B06588A	Coil 21mH	C008	0B05638A	Tantalum Capacitor 1 μ 35V
R001	0B05622A	Carbon Resistor 2.2K ERD-25T J	C009,010	0B05790A	SP Capacitor 1200P 50V J
R002,007	0B01888A	Carbon Resistor 10K ERD-25T J	C012	0B05772A	Tantalum Capacitor 0.22 μ 35V
008			C015	0B05796A	Mylar Capacitor 0.047 μ 50V J
R003	0B05508A	Carbon Resistor 56K ERD-25T J	C016	0B01400A	Electrolytic Capacitor 100 μ 16V
R004,005	0B01681A	Carbon Resistor 3.3K ERD-25T J	0B08610A	Shield Plate N604 (1 pce.)	
R006	0B05614A	Carbon Resistor 1.8K ERD-25T J	0B03924A	Gate Pin (2 pcs.)	
R009,010	0B05671A	Carbon Resistor 2.2M ERD-25T J			

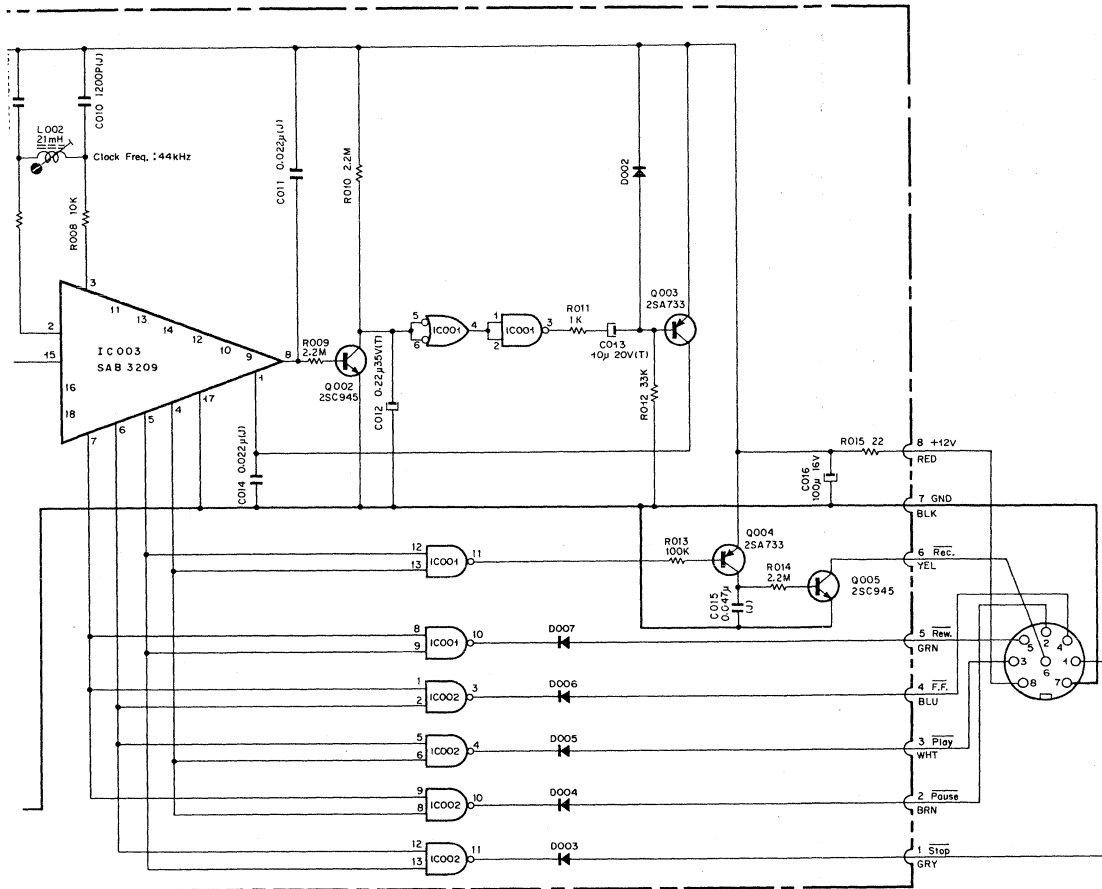

Fig. 15.2.1

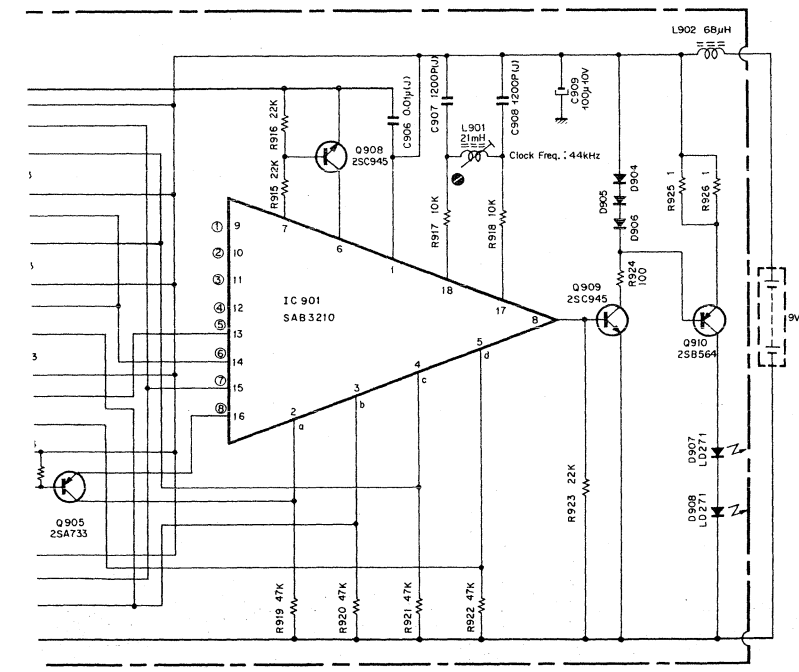

Fig. 15.2.2

Mechanism Ass'y and Parts List
Receiver

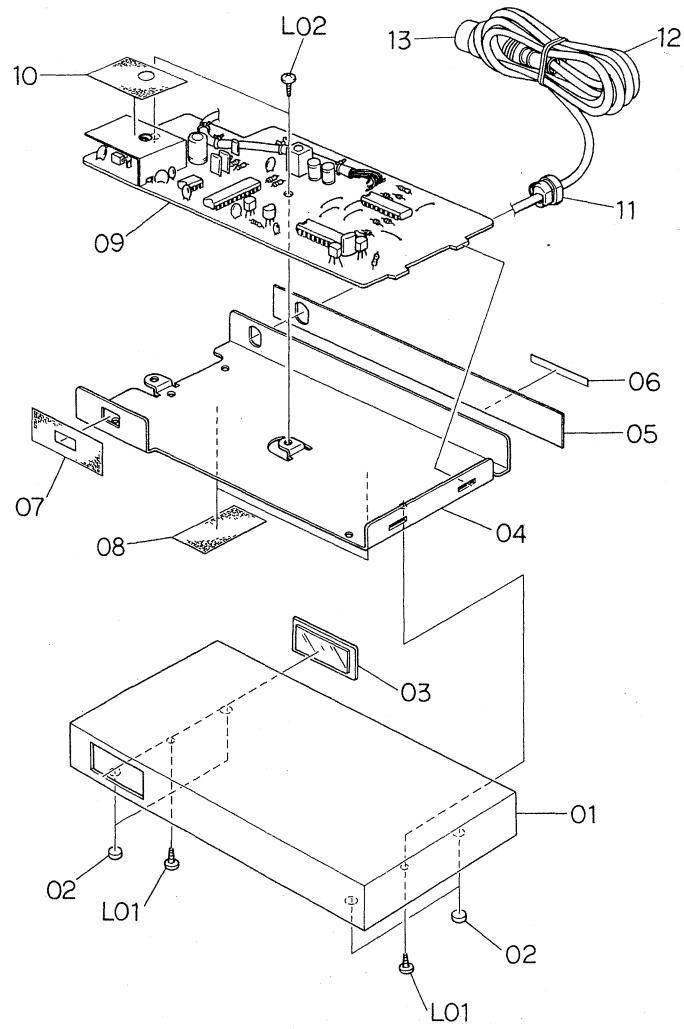

Fig. 15.4.1

Schematic Ref. No.	Part No.	Description	Q'ty
		Remote Receiver Ass'y	
01	0H03702B	Receiver Case	1
02	0A03285B	Leg RM 580	4
03	0H03649A	Acrylic Cover	1
04	0J03995B	Receiver Chassis	1
05	0M03975D	Rear Plate	1
06	0M03982A	Serial No. Seal (Receiver)	1
07	0J03996A	Chassis Mask	1
08	0J04008A	Chassis Himelon	2
09	BA04002A	Remote Receiver P.C.B. Ass'y	1
10	0J04007A	P.C.B. Himelon	1
11	0B08587A	Cord Bushing	1
12	0B05222B	8P Cord	1
13	0B08585A	8P DIN Plug	1
L01	0E00860A	BT Screw M3x6 Philips Binding Head (Bronze)	2
L02	0E00857A	BT Screw M3x6 Philips Binding Head	2

15.4.2. Transmitter

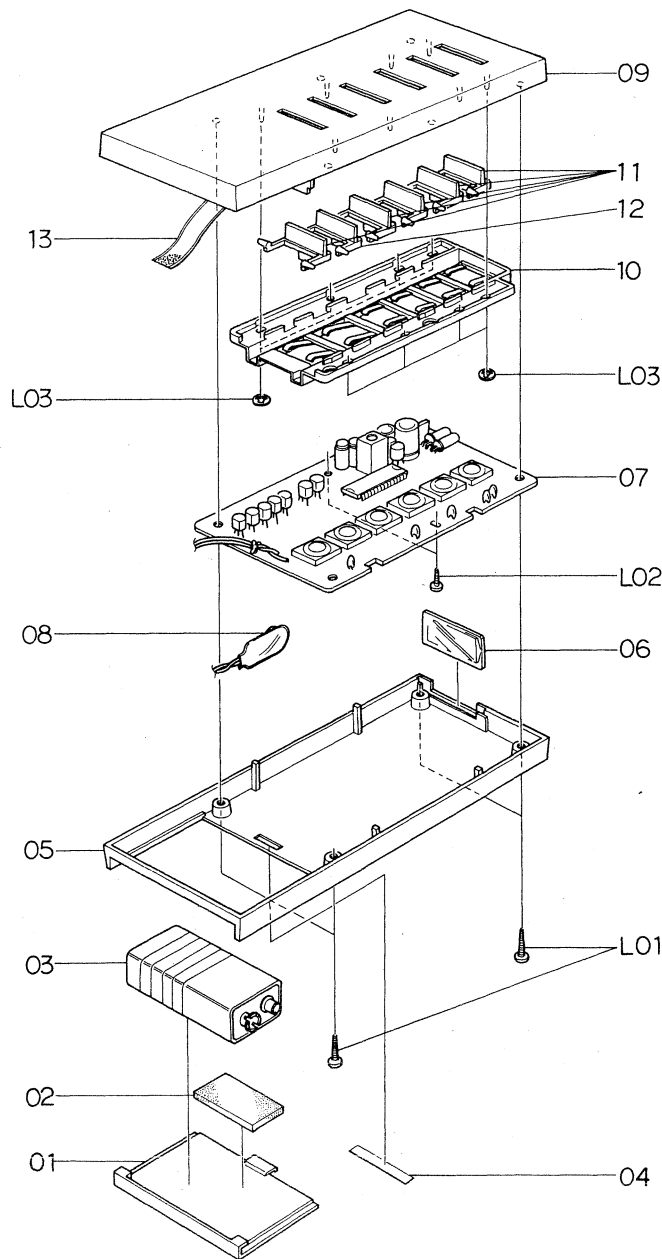

Fig. 15.4.2

Schematic Ref. No.	Part No.	Description	Q'ty	Schematic Ref. No.	Part No.	Description	Q'ty
		Remote Transmitter Ass'y		10	0J03994B	Spring Plate	1
01	0H03705A	Battery Cover	1	11	0H03659A	Control Button B	5
02	0J03905A	Battery Cushion	1	12	0H03658A	Control Button A	1
03	0B08529A	Battery 9V	1	13	0J03906A	Battery Ribbon	1
04	0M03976A	Serial No. Seal (Transmitter)	1	L01	0E00825A	BT Screw M2.6x8 Philips Binding Head	4
05	0H03704A	Bottom Case	1	L02	0E00824A	BT Screw M2.6x6 Philips Pan Head	2
06	0H03657A	Smoked Filter	1	L03	0E00874A	Stopper Ring CS 2mm	8
07	BA04004A	Remote Transmitter P.C.B. Ass'y	1				
08	0B05223B	Battery Snap B 110mm	1				
09	0H03701C	Top Case	1				

16. SPECIFICATIONS

Power Source	100, 120, 120/220-240, 220 or 240 V; 50/60 Hz
Power Consumption	23 W Max.
Tape Speed	1-7/8 ips. (4.8 cm/sec.) $\pm 0.5\%$
Wow and Flutter	Less than 0.1% WTD Peak, 0.05% WTD rms
Frequency Response	20-20,000 Hz ± 3 dB (-20 dB Rec. Level)
Signal to Noise Ratio	Better than 60 dB at 400 Hz, 0 dB, IHF-A WTD rms
(Dolby NR In, ZX Tape)	Better than 64 dB at 400 Hz, 3% THD, IHF-A WTD rms
Total Harmonic Distortion	Less than 1.0% at 400 Hz, 0 dB, ZX Tape Less than 1.2% at 400 Hz, 0 dB, SX Tape Less than 1.0% at 400 Hz, 0 dB, EXII Tape
Erasure	Better than 60 dB below saturation level at 1 kHz ZX Tape
Separation	Better than 37 dB at 1 kHz, 0 dB
Crosstalk	Better than 60 dB at 1 kHz, 0 dB
Bias Frequency	105 kHz
Input	50 mV, 50 k ohms
Output Level	1 V (400 Hz, 0 dB, Output Level at Max.) 3.3 k ohms
Headphone	45 mW
Dimensions	500(W) x 130(H) x 350(D) m/m 19-11/16(W) x 5-1/8(H) x 13-25/32(D) inches
Approximate Weight	8.3 kg, 18 lb 5 oz.

- Specifications and appearance design are subject to change for further improvement without notice.
- Dolby NR under license from Dolby Laboratories.
- The word "DOLBY" and the Double-D-Symbol are trademarks of Dolby Laboratories.