

RECEIVED

- 5 APR 1976

ANSD.



Nakamichi

Service Manual

Donald Sangster c/r

Thames Environmental Consultancy

P.O. Box 1
THAMES
Ph. 07 868-3079



**MASTER COPY
DO NOT DISTRIBUTE**

Nakamichi 600

Number 3843488

2Head Cassette Console

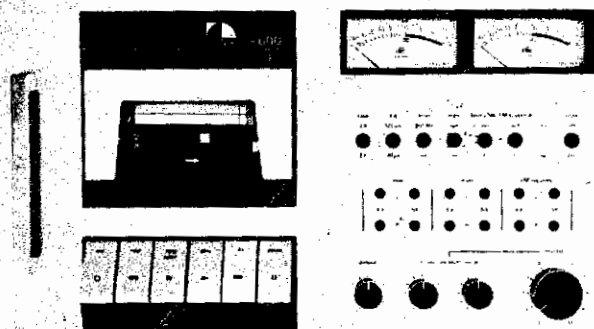

CONTENTS

1. General	3
2. Principle of Operation	5
2. 1. P.B. Eq. Amp. Circuit	5
2. 2. I.M. Suppressor	6
2. 3. Unattended Record or Playback, and Shut-off Circuit	7
2. 3. 1. Unattended Record or Playback	7
2. 3. 2. Shut-off Circuit	7
3. Removal Procedures	10
3. 1. Cabinet	10
3. 2. Front Panel	10
3. 3. Mechanism Ass'y	10
3. 4. Record/Playback Head, Erase Head and Pressure Roller	10
3. 4. 1. Record/Playback Head	10
3. 4. 2. Erase Head	10
3. 4. 3. Pressure Roller	10
3. 5. Cassette Case Ass'y	10
3. 6. Cassette Lid Ass'y	10
3. 7. Control Button	11
3. 8. Counter Holder Ass'y	11
3. 9. Reel Hub Ass'y (Supply, Take-up)	11
3. 10. Motor and Motor Governor Ass'y	12
3. 11. Flywheel	12
3. 12. Idler Pulley	12
3. 13. Front Control Ass'y	12
3. 14. Main P.C.B. Ass'y	12
3. 15. Dolby P.C.B. Ass'y	12
3. 16. Record Link Ass'y	12
3. 17. VR P.C.B. Ass'y	12
3. 18. Meter Ass'y	12
3. 19. Power Supply P.C.B. Ass'y	12
3. 20. Power Switch Ass'y	12
4. Measurement and Maintenance Instruments	13
4. 1. Measurement Instruments	13
4. 2. Maintenance Instruments	13
5. Mechanical Adjustments	15
5. 1. Take-up Torque and Rewind Torque Adjustment	15
5. 2. Tape Speed Adjustment	15
5. 3. Record/Playback Head Height Adjustment and Azimuth Alignment	15
5. 4. Head Base Stroke Adjustment	15
5. 5. Pause Timing Adjustment	16
5. 6. Belt Travelling Adjustment	16
5. 7. Flywheel Adjustment	16
5. 8. Brake Timing Adjustment	16
5. 9. Mute SW. and Start SW. Timing Adjustment	17
5. 10. Solenoid Position Adjustment	17
5. 11. Record Link Adjustment	18
5. 12. Lubrication	18
5. 13. Tape Travelling Adjustment	19
6. Electrical Adjustments and Measurements	20
6. 1. Adjustment and Measurement Instructions	20
6. 2. Frequency Response Adjustment	23
6. 2. 1. Playback Frequency Response Adjustment	23
6. 2. 2. Record Current Frequency Response Adjustment	23
7. Parts Location for Electrical Adjustment	24

8. Mounting Diagram & Parts List	25
8. 1. Main P.C.B. Ass'y	25
8. 2. Dolby P.C.B. Ass'y	27
8. 3. SW. P.C.B. Ass'y	28
8. 4. CAL. P.C.B. Ass'y	28
8. 5. VR P.C.B. Ass'y	29
8. 6. DIN Pin Jack P.C.B. Ass'y	29
8. 7. Meter P.C.B. Ass'y	29
8. 8. Power Supply P.C.B. Ass'y	30
8. 9. Shut-off P.C.B. Ass'y	31
8. 10. MHX Governor P.C.B. Ass'y	32
9. Mechanism Ass'y & Parts List	33
9. 1. Synthesis Ass'y (A01)	33
9. 2. Chassis Ass'y	34
9. 2. 1. Chassis Ass'y (A02-1)	34
9. 2. 2. Chassis Ass'y (A02-2)	35
9. 3. N600 Mechanism Ass'y (A03)	37
9. 4. Front Control Ass'y (A04)	38
9. 5. Record Link Ass'y (A05)	39
9. 6. Push Button Ass'y (A06)	39
9. 7. Power Trans. Ass'y (A07)	39
9. 8. Power SW. Ass'y (A08)	39
9. 9. Meter Ass'y (A09)	39
9. 10. N600 Mechanism Sub Ass'y	41
9. 10. 1. N600 Mechanism Sub Ass'y (B01-1)	41
9. 10. 2. N600 Mechanism Sub Ass'y (B01-2)	41
9. 11. Cassette Case Ass'y (B02)	43
9. 12. Head Base (B) Ass'y (B03)	43
9. 13. Counter Holder Ass'y (B04)	43
9. 14. Reel Hub T (B) Ass'y (B05)	43
9. 15. Reel Hub S (B) Ass'y (B06)	43
9. 16. Flywheel Holder (C) Ass'y (B07)	43
9. 17. MHX Motor Ass'y (B08)	44
9. 18. Record/Playback Head Ass'y (B09)	44
10. Wiring Diagram	45
11. Eq. Amp. Frequency Response	46
11. 1. Playback Frequency Response	46
11. 2. Record Current Frequency Response	46
12. Block Diagram	46
13. Schematic Diagram (Amp.)	47
14. Schematic Diagram (Mechanism)	48
15. Specifications	49
16. Trouble Shooting	49
16. 1. Note	49
16. 2. Trouble Shooting	49
16. 3. Check method when parts are replaced	52

1. GENERAL

Nakamichi 600 control functions are shown with reference to the following explanations.

For keeping the optimum performance of Nakamichi 600, maintenance such as cleaning of head, capstan shaft and pressure roller, and demagnetization of heads, lubrication, etc. is required.

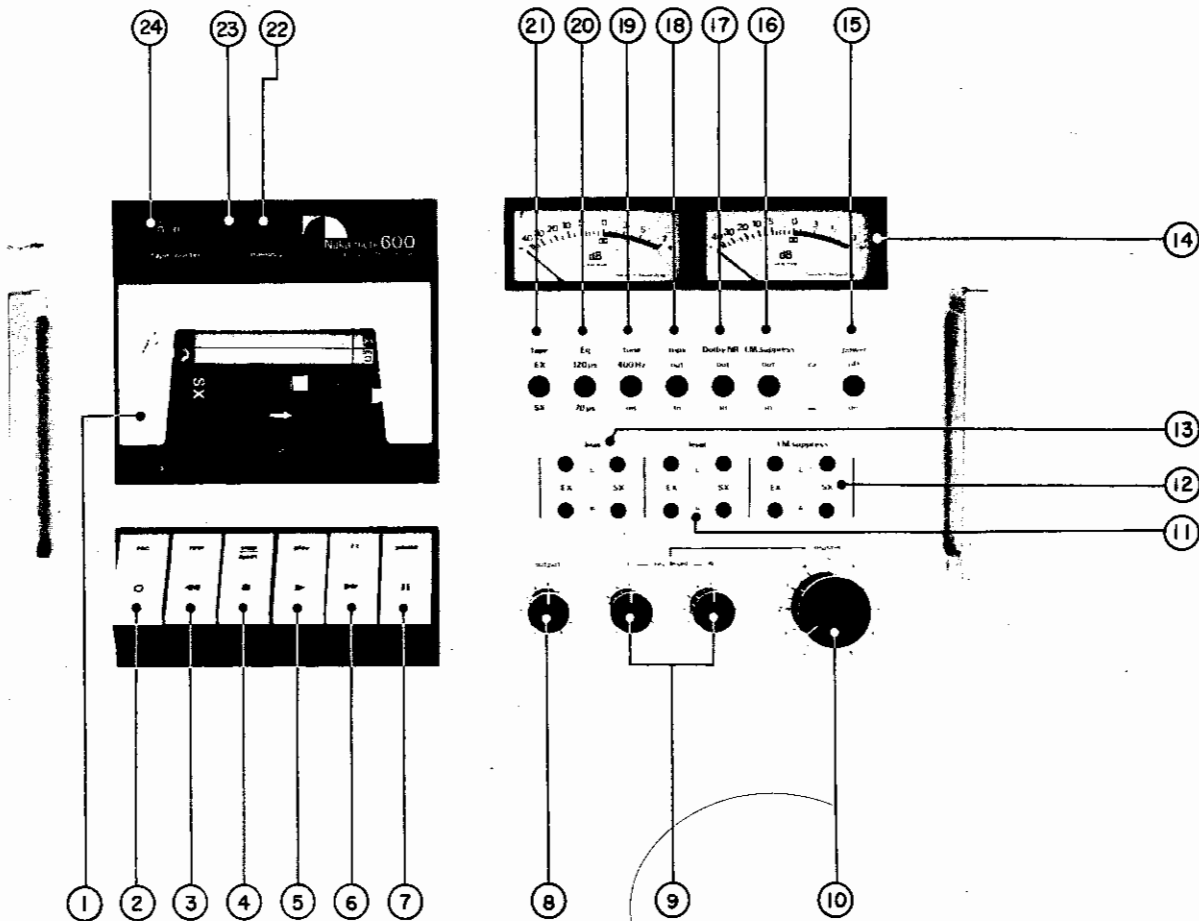

Fig. 1. 1 Front View

- | | |
|----------------------------------|-------------------------------|
| 1. Cassette Lid | 15. Power Switch |
| 2. Record Button | 16. I. M. Suppress Switch |
| 3. Rewind Button | 17. Dolby NR Switch |
| 4. Stop/Eject Button | 18. MPX Switch |
| 5. Playback Button | 19. Tone Switch |
| 6. Fast Forward Button | 20. Eq. Switch |
| 7. Pause Button | 21. Tape Switch |
| 8. Output Level Control | 22. Tape Start Memory Switch |
| 9. Input Level Controls (L/R) | 23. Tape Counter Reset Button |
| 10. Input Level Control (Master) | 24. Tape Counter |
| 11. Record Level Cal. Volume | 25. Line Input Jacks |
| 12. I. M. Suppress Cal. Volume | 26. DIN Socket |
| 13. Bias Adj. Volume | 27. Line Output Jacks |
| 14. Peak Level Meter | 28. Voltage Selector |

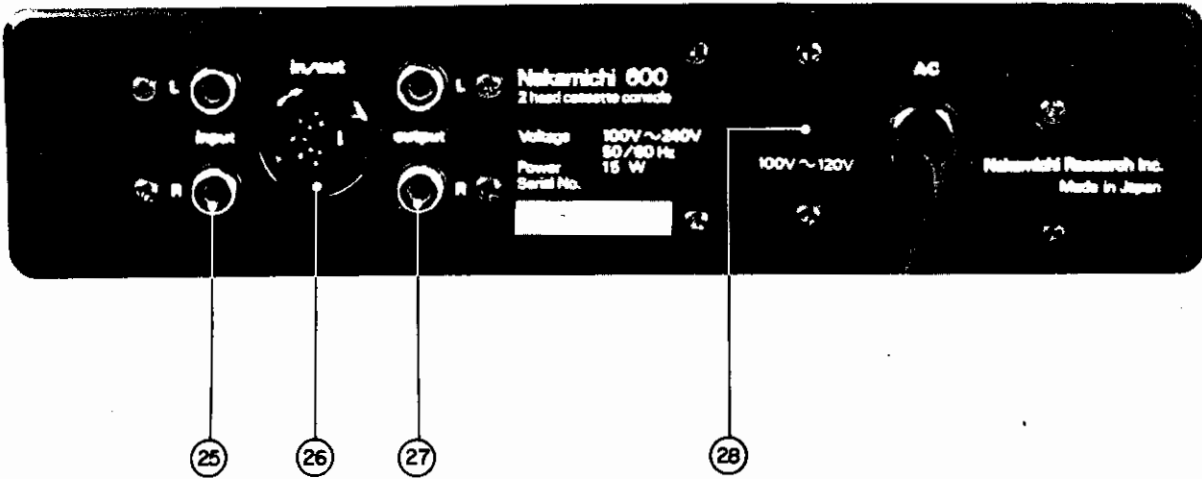

Fig. 1.2 Rear View

Voltage Selector

Change-over either to 100 ~ 120V or 220V ~ 240V.

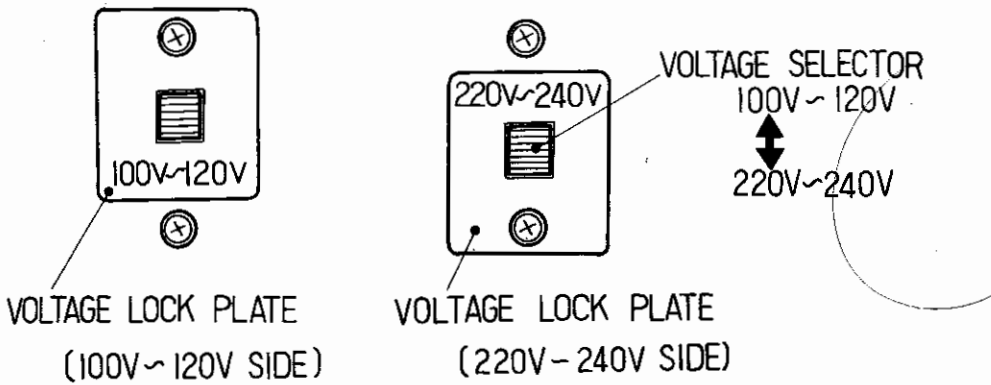

Fig. 1.3

Note 1: When cassette lid is opened, no control button operates.

Note 2: When mechanism ass'y is reassembled, check to insure whether the record link ass'y (see Fig. 9.2.2) is fixed to the correct position, i.e. when record button is depressed (cassette is loaded), record link acts.

Note 3: When memory counter indicates "000" to "010" memory rewind stop function (stops at "999") does not operate because of lacking in the electric charge for the capacitor (Shut-off P.C.B.) which will conduct to drive the solenoid.

Note 4: Dolby NR under license from Dolby Laboratories Inc. The word "DOLBY NR" and the Double-D-Symbol are trademarks of Dolby Laboratories Inc.

2. PRINCIPLE OF OPERATION

2.1. P.B. Eq. Amp. Circuit

Fig. 2.1.1 shows the playback equalizer circuit, and Fig. 2.1.2 is its system diagram. Fig. 2.1.3 shows the time constant of equalizer. The playback head is connected with circuit's input.

Amplifier 1 (Q101 and Q102) is an equalizer amplifier and its time constant is illustrated in Fig. 2.1.3.

R, L and C compose a peaking circuit. This circuit compensates the air gap loss of the playback head so that high-frequency response may be improved.

Phase shifter acts to compensate the phase delay characteristics of the frequency response. Phase delay characteristics are improved within 30 degrees up to 10KHz. Therefore modulation for the complex wave will reduce.

P.B. Eq. Amp. gain is adjusted by semi-fixed volume VR101 (Amp. 2-Q104, 105) to obtain 580mV output level when 400Hz P.B. Reference Tape (DA09005A) is being played back.

I.M. Suppressor circuit (Intermodulation Suppressor) is located between Amp 2 and Amp 3 (Q106), and circuit is connected with front panel I.M. Suppress "In" and disconnected from "Out". Refer to the item 2.2, I.M. Suppressor circuit.

Equalizer switch (70μ/120μ) is connected with Amp 3.

The overall time constants in P.B. Eq. Amp. are as follows:

Eq. SW. - 70μs
3180μ (50Hz) + 70μ (2275Hz)

Eq. SW. - 120μs
3180μ (50Hz) + 120μ (1326Hz)

Shown below is the table for the position of tape switch and Eq. switch.

Tape SW.	Eq. SW.	Tape
SX	70μ	Nakamichi SX TDK SA
EX	120μ	Low-Noise High-Density (Including EX, EX II)
EX	70μ	Nakamichi EX, EX II

When 70μ is selected at EX tape position, signal to noise ratio will be improved by 4.7dB (WTD).

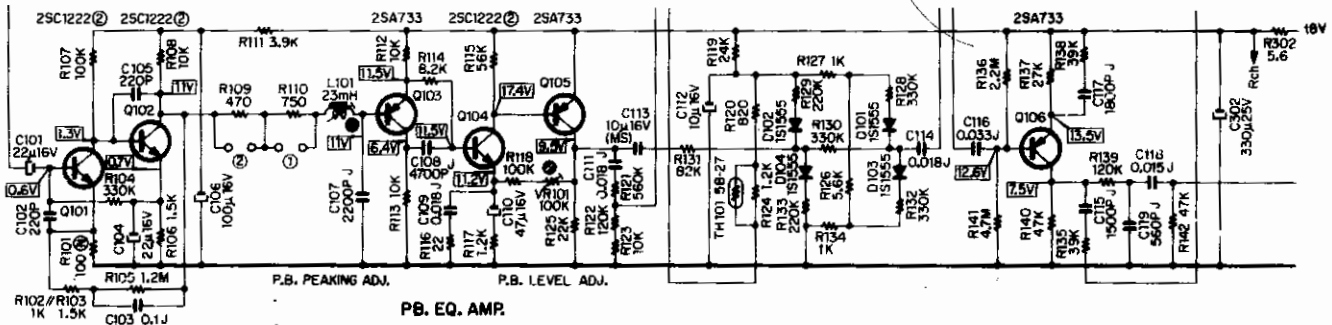

Fig. 2. 1. 1 P.B. Eq. Amp. Circuit

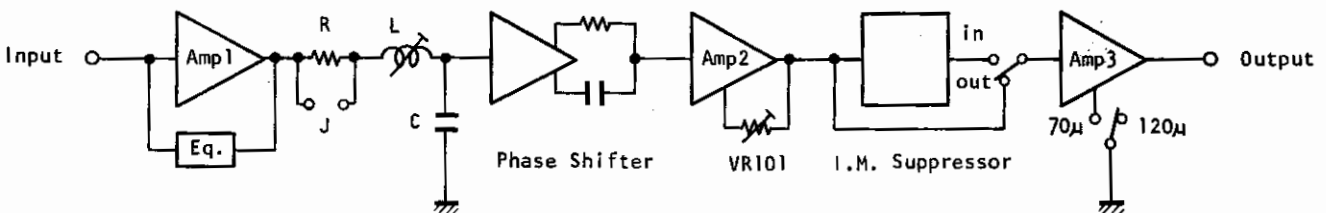

Fig. 2. 1. 2 P.B. Eq. Amp. System Diagram

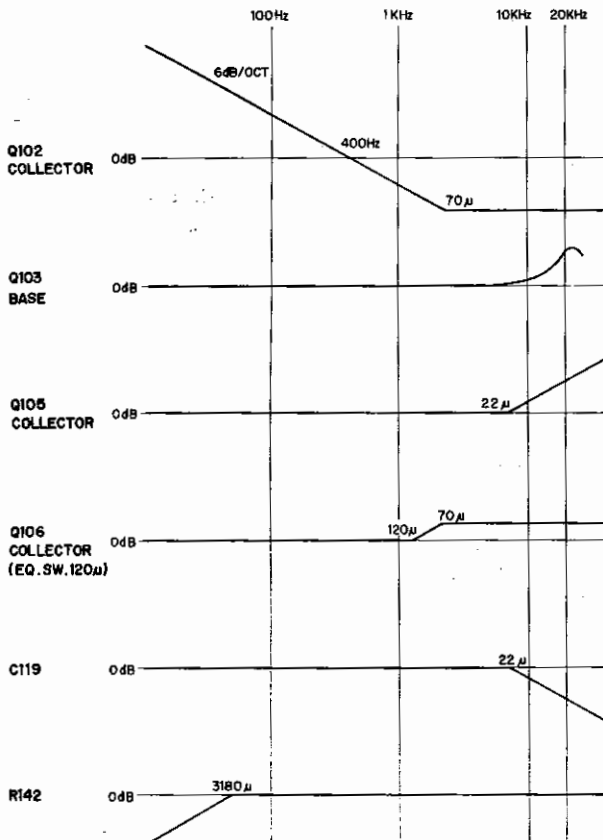

Fig. 2. 1. 3 P.B. Eq. Amp. Time Constant

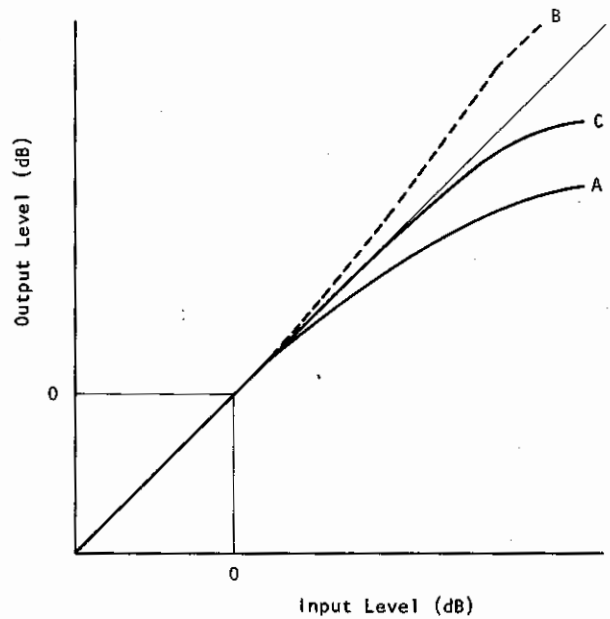

Fig. 2. 2. 1 I.M. Suppressor Input vs. Output Characteristics

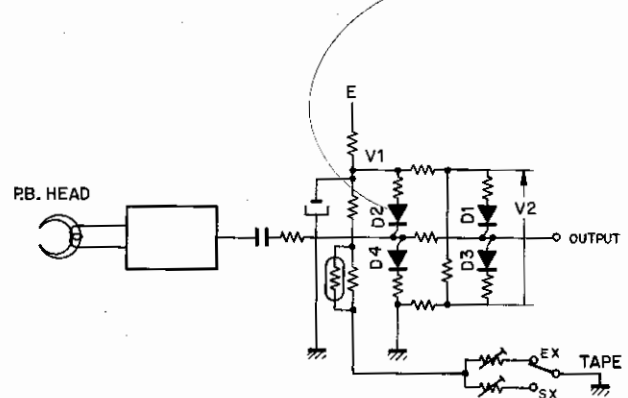

Fig. 2. 2. 2 I.M. Suppressor Circuit

2.2. I. M. Suppressor

Fig. 2.2.1 shows the input vs. output characteristics at 400Hz of Nakamichi 600.

While input level is small, output level is in proportion to input level. But when input level exceeds a certain point, output will not be in proportion to input but has a tendency to saturate (curve A) because of disadvantages due to the magnetic properties of tape.

I.M. Suppressor (Intermodulation Suppressor), while playing back playback amp. gain is compensated as shown by curve B so that overall characteristics becomes curve C. Curve C allows recording at higher levels than normally possible by reducing the saturation and distortion.

I.M. Suppressor circuit is shown in Fig. 2.2.2.

Circuit consists of resistors and diodes which are composed attenuator, and semi-fixed volume which determines the I.M. Suppressor action level.

The voltage (V1) is adjusted by semi-fixed volume to obtain minimum reading of total harmonic distortion at 400Hz 0dB for the tape to be used.

While input signal level is small, diodes D1 to D4 are On and static operating point level of the output signal is V1/2. When input signal exceeds V2/2, D1 and D3 are cut off. Accordingly attenuation decreases, i.e. gain increases. In case input signal exceeds V1/2, D2 and D4 are also cut off.

Diodes D1 to D4 act as variable resistors until it is cut off, because it is used at small electric current. And resistance varies according to the value of the applied voltage to the diode.

2.3. Unattended Record or Playback, and Shut-off Circuit

2.3.1. Unattended Record or Playback

- (1) Depress the record button then depress the play button (Depress only the play button for unattended playback).
- (2) Depress the pause button.
- (3) Turn Off the external power source.
- (4) When external power turns On, approximately 4 seconds after the transport will automatically release itself from the pause mode and begin to record (or play).

2.3.2. Shut-off Circuit

Fig. 2.3.1 and 2.3.2 show the shut-off circuit and timing chart. Fig. 2.3.3 shows the flow chart for the shut-off function.

Following are explanations according to the order of the flow chart Nos.:

(1) External Power On

When external power is turned On at attended record or playback mode, transistor Q606 turns to On approximately 4 seconds later. By the Q606 On, differentiated positive pulse is added to the Q602 base through capacitor C607.

Then Q602 turns to On and Q601 base current flows. Q601 turns to On and base current of the Q602 is supplied through Q601.

Therefore Q602 and Q601 construct memory circuit when trigger is added to the Q601 base.

When Q601 turns to On solenoid is driven through the charge of C606 (2200 μ F).

As resistance of the solenoid is about 12 ohm, an electric charge of C606 is discharged quickly while C606 is charging through resistor R615 (470 ohm). And about 70 msec after the voltage of Q601 collector becomes less than about 1.2V, then enough base current does not flow to the Q602 and therefore Q602 turns to Off and Q601 turns to Off.

C606 starts charging again preparing for the next solenoid drive.

From the above, solenoid works as a pulse motion. Solenoid action will release the pause button.

(2) Tape End

At a tape end, magnet pulley which is assembled with tape counter stops and therefore reed switch On/Off stops. Therefore the discharge of the C604 through Q604 (synchronizing with the periodic reed switch On/Off) stops. While C604 is kept to charge about by 4.5V, Q603 turns to On and Q601 turns to On.

The action of the solenoid is the same as item (1). Solenoid acts to release the play, record, FF and REW buttons (therefore start switch will open).

(3) Stop Button Depressing

When stop button is depressed, play, record, FF and REW buttons are released mechanically.

(4) Power Off

DC power supply (+18V) will discharge by the power switch off. While the C606 time constant is great, Q605 turns to On then Q603 turns to On then Q601 turns to On.

Solenoid is driven and control buttons are released.

In case pause button is depressing, solenoid does not work because Q603 base is connected to ground through pause button, and no control button is released.

(5) Memory Rewind

When the tape counter reaches "999" counter switch closes. At memory switch On and rewind mode, the differentiated negative trigger pulse is added to the Q601 base and Q601 turns to On. And solenoid is driven.

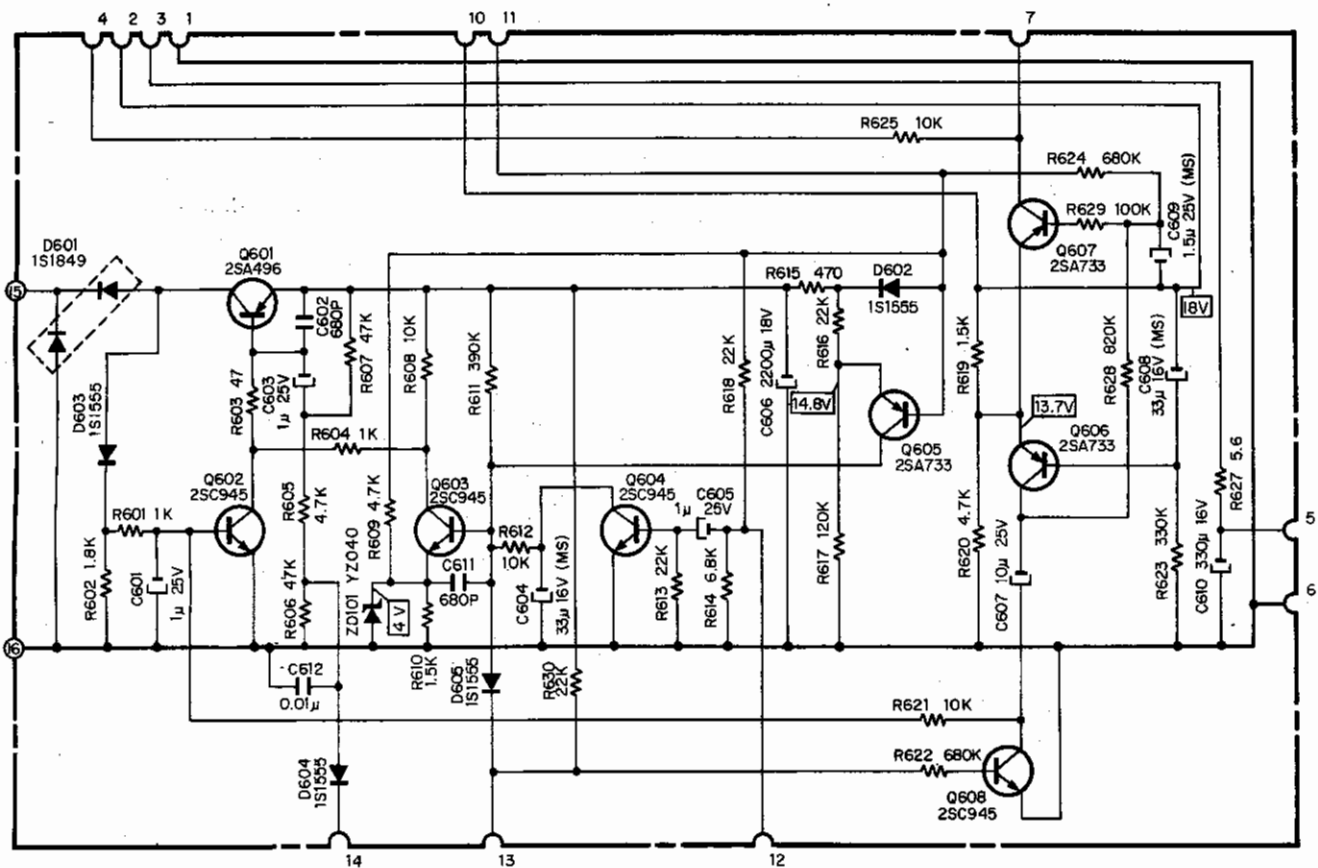

Fig. 2. 3. 1 Shut-off Circuit

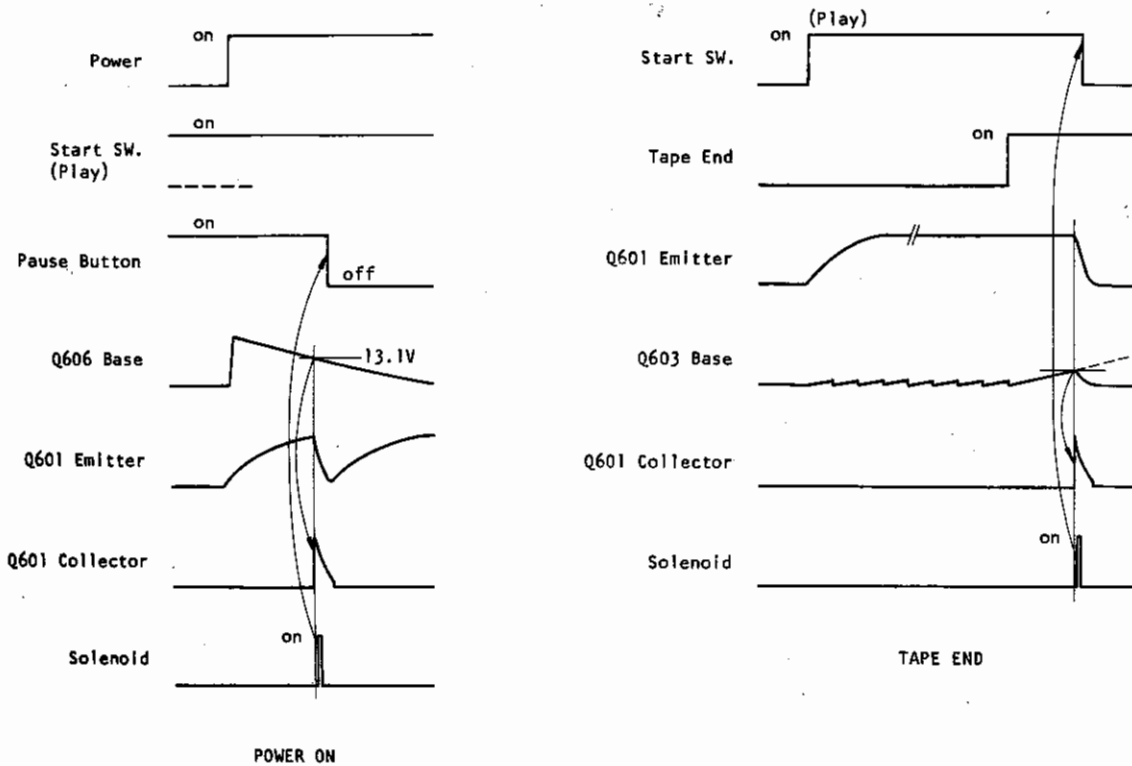

Fig. 2. 3. 2 Shut-off Timing Chart

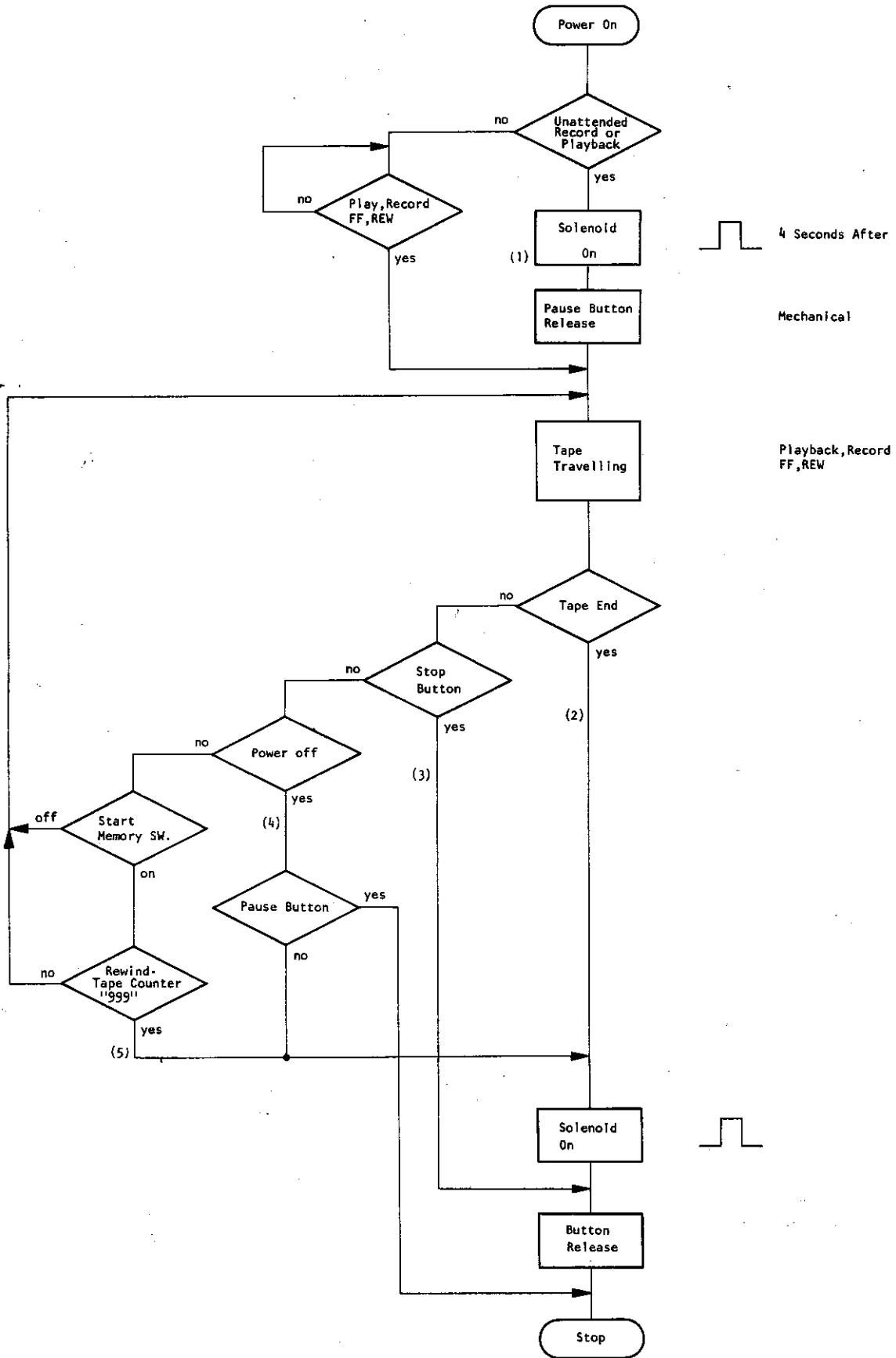

Fig. 2. 3. 3 Shut-off Flow Chart

3. REMOVAL PROCEDURES

3.1. Cabinet

Refer to the Fig. 9.1 (A01) and remove (F01) (five spots).

3.2. Front Panel

Refer to the Fig. 9.1 (A01) and remove (F01) through (F06).

3.3. Mechanism Ass'y

Remove the cabinet and front panel (3.1, 3.2).

Refer to the Fig. 9.2.1 (A02-1) and remove (F01) through (F03).

3.4. Record/Playback Head, Erase Head and Pressure Roller

Remove the cabinet and front panel (3.1, 3.2).

Then depress the play button.

Refer to the Fig. 3.1.

3.4.1. Record/Playback Head

Remove (F02) through (F04).

3.4.2. Erase Head

Remove (F05) through (F08).

3.4.3. Pressure Roller

Remove (F01).

Note: When record/playback head is replaced, twist the signal wires (red and white) which are soldered to head terminals for reducing the influence of hum.

3.5. Cassette Case Ass'y

Remove the mechanism ass'y (3.3).

Refer to the Fig. 3.2 and remove (F01) through (F07).

Remove (F04) and (F05) by pincers with care.

3.6. Cassette Lid Ass'y

Remove the cassette case ass'y (3.5).

Refer to the Fig. 3.2 and remove (F08) through (F12). (F13), lid cover is bonded to (F12).

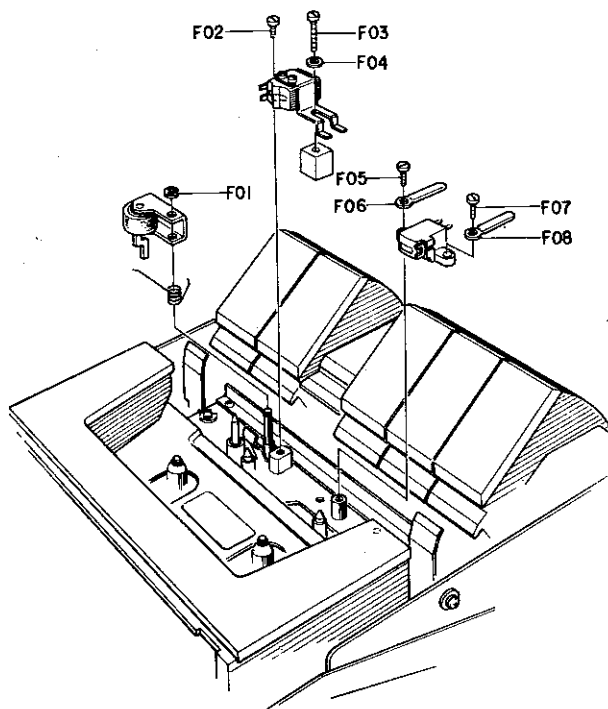

Fig. 3.1

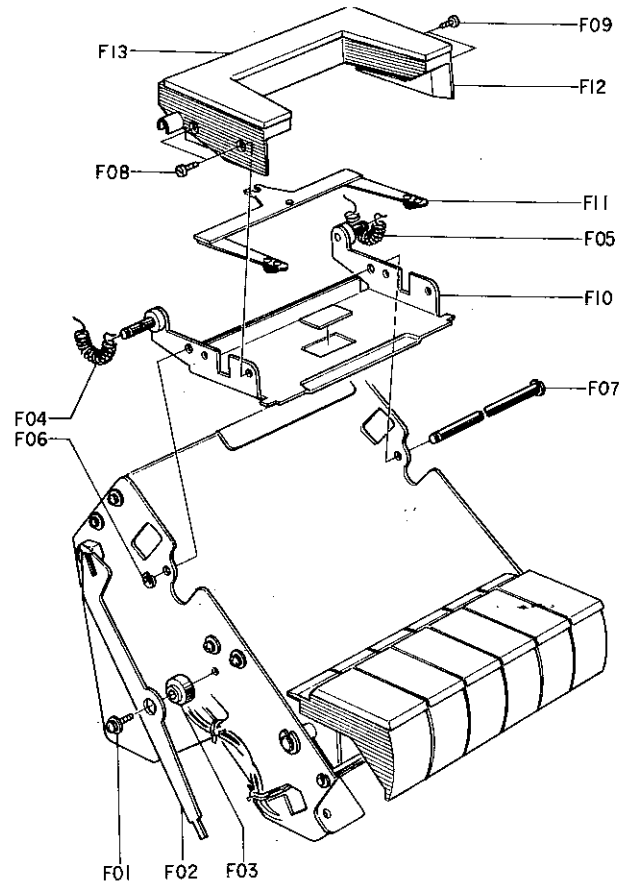

Fig. 3.2

3.7. Control Button

Remove the mechanism ass'y (3.3).

Refer to the Fig. 3.3 and remove (F01) through (F05).

Note: Following are assembled in pair.

F06-F07, F08-F09, F10-F11, F13-F14, F15-F16

3.8. Counter Holder Ass'y

Remove the front panel (3.2).

Refer to the Fig. 3.4 and remove (F01).

Remove (F02) through (F06) then counter ass'y and memory switch, and reed switch will be removed.

Note: The reed switch terminal shall not be in contact with the chassis.

3.9. Reel Hub Ass'y (Supply, Take-up)

Remove the cassette case ass'y (3.5).

Refer to the Fig. 3.5 and remove (F01) and (F02).

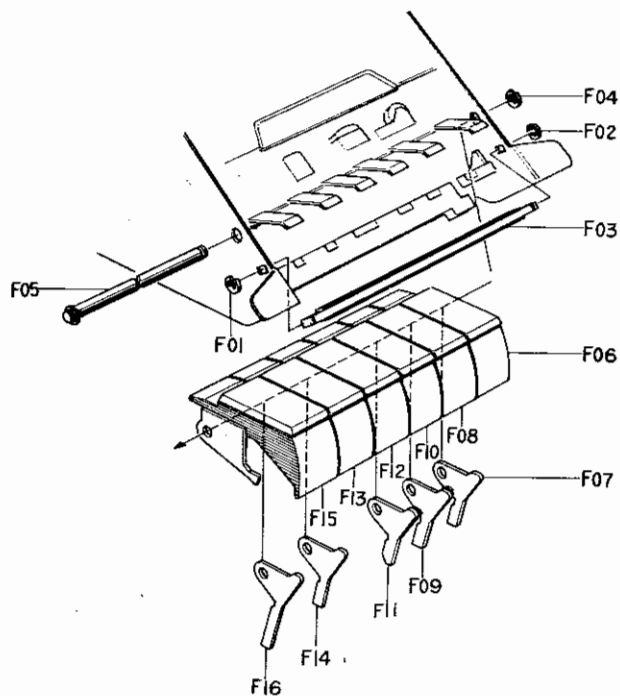

Fig. 3.3

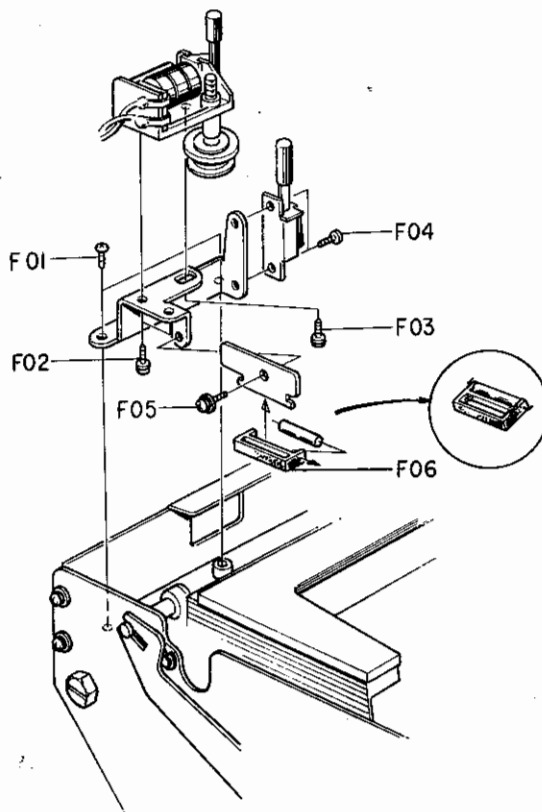

Fig. 3.4

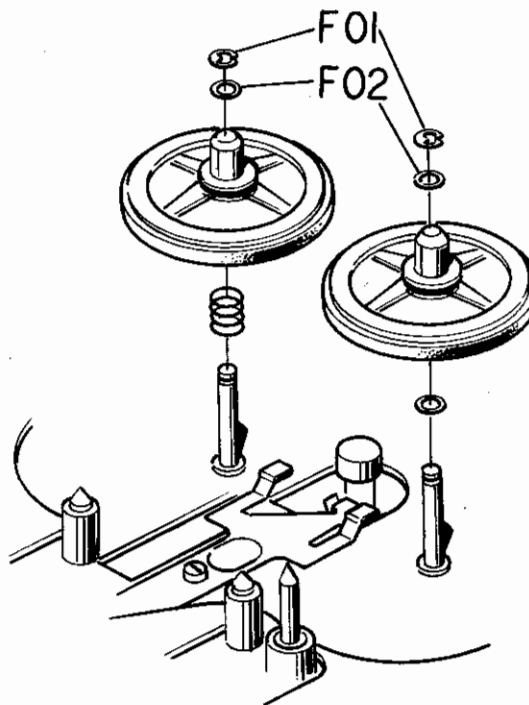

Fig. 3.5

3.10. Motor and Motor Governor Ass'y

Remove the mechanism ass'y (3.3).

Refer to the Fig. 3.6 and remove (F01) then move the solenoid.

Remove (F02) through (F08) so that governor ass'y is removed.

Remove (F09) and lift the motor then remove (F10) and (F11).

Then loosen (F12) and remove (F13) so that motor is removed.

Note: Readjustment of solenoid position, belt travelling, tape speed and wow/flutter will be required.

3.11. Flywheel

Remove the mechanism ass'y (3.3).

Refer to the Fig. 3.7 and remove (F01) through (F05) then remove the belt and flywheel (F06).

Note: Readjust the clearance between flywheel and flywheel holder. Belt travelling, tape speed and wow/flutter check will be required.

3.12. Idler Pulley

Remove the Flywheel (3.11). Refer to the Fig. 3.7 and remove (F07) through (F09).

Note: Readjust the brake timing. Belt travelling, tape speed and wow/flutter check will be required.

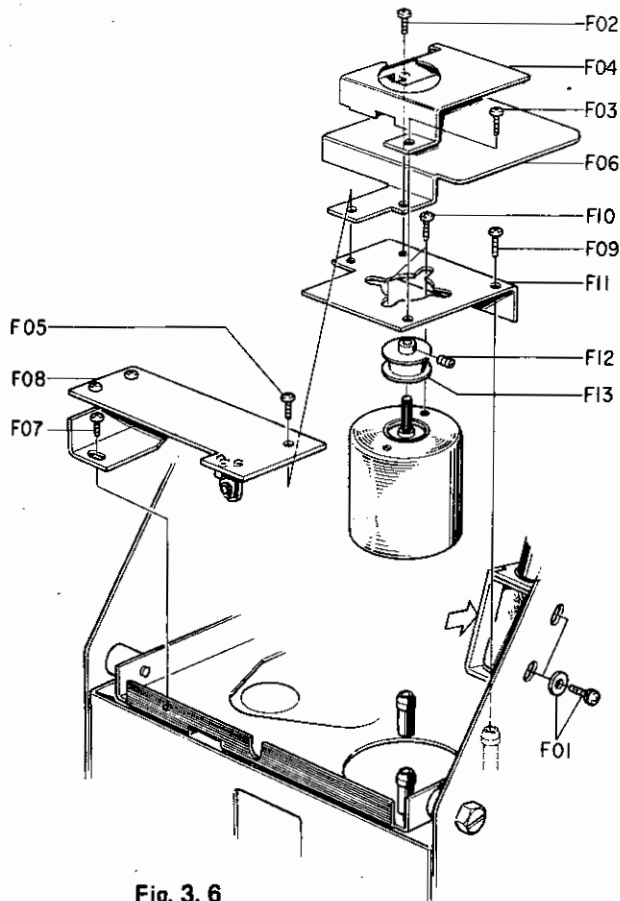

Fig. 3.6

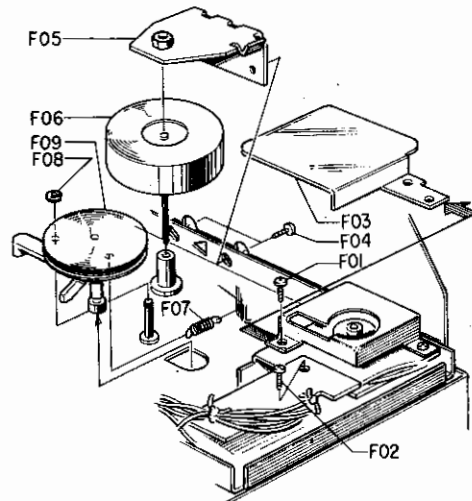

Fig. 3.7

3.13. Front Control Ass'y

Remove the cabinet and front panel (3.1, 3.2).

Refer to the Fig. 9.2.1 (A02-1) and remove (F05).

3.14. Main P.C.B. Ass'y

Remove the front control ass'y (3.13).

Refer to the Fig. 9.2.2 (A02-2) and remove (F01) through (F04).

Remove (F05), main P.C.B. ass'y.

3.15. Dolby P.C.B. Ass'y

Remove the main P.C.B. ass'y (3.14).

Unplug the Dolby P.C.B. (F06) from the main P.C.B.

3.16. Record Link Ass'y

Remove the main P.C.B. ass'y (3.14).

Refer to the Fig. 9.2.2 (A02-2) and remove (F12) and (F13).

3.17. VR P.C.B. Ass'y

Remove the cabinet and front panel (3.1, 3.2).

Refer to the Fig. 9.2.1 (A02-1) and remove (F07) through (F09).

3.18. Meter Ass'y

Remove the cabinet and front panel (3.1, 3.2).

Refer to the Fig. 9.2.2 (A02-2) and remove the (F07) and (F08).

3.19. Power Supply P.C.B. Ass'y

Remove the cabinet (3.1).

Refer to the Fig. 9.2.2 (A02-2) and remove (F21) through (F23).

3.20. Power Switch Ass'y

Remove the main P.C.B. (3.14).

Refer to the Fig. 9.2.2 (A02-2) and remove (F09) through (F11).

4. MEASUREMENT AND MAINTENANCE INSTRUMENTS

4.1. Measurement Instruments

- (1) Audio Generator (20Hz – 200KHz)
- (2) AC Milivolt Meter (with dB measures)
- (3) Oscilloscope (DC – 5MHz)
- (4) Distortion Meter
- (5) Speed & Wow/Flutter Meter
- (6) Frequency Counter (DC – 1MHz)
- (7) Ohm Meter
- (8) DC Volt Meter
- (9) AC Volt Meter
- (10) Tape Travelling Cassette B (part No. DA09027A)
- (11) Torque Gauge (DA09013A)
- (12) 15KHz Azimuth Tape (DA09004A)
- (13) 3KHz Speed & Wow/Flutter Tape (DA09006A)
- (14) 1KHz Track Alignment Tape (DA09007A)
- (15) 400Hz Level Tape (DA09005A)
- (16) 20KHz P.B. Frequency Response Tape (DA09001A)
- (17) 15KHz P.B. Frequency Response Tape (DA09002A)
- (18) 10KHz P.B. Frequency Response Tape (DA09003A)
- (19) Reference EXII Tape (DA09021A)
- (20) Reference SX Tape (DA09025A)
- (21) Track Viewer (DA09012A)
- (22) Tape Guide Adjuster (0D09001A)
- (23) Information Terminals, Model M-300
(For positioning of record/playback head)

4.2. Maintenance Instruments

Refer to the Fig. 4.1 Extension Cord Connection.

- (1) Extension cord (10p) (part No. DA09020A)
- (2) Extension cord (14p) (DA09016A)
- (3) Extension cord (38p) (DA09026A)

Note: Refer to the item 3 "Removal Procedures".

When a check is made on Amp. etc. by means of an extension cord, re-adjustment shall be made without fail (after final installation to the model chassis). The check without removal of an extension cord will cause inaccurate adjustments.

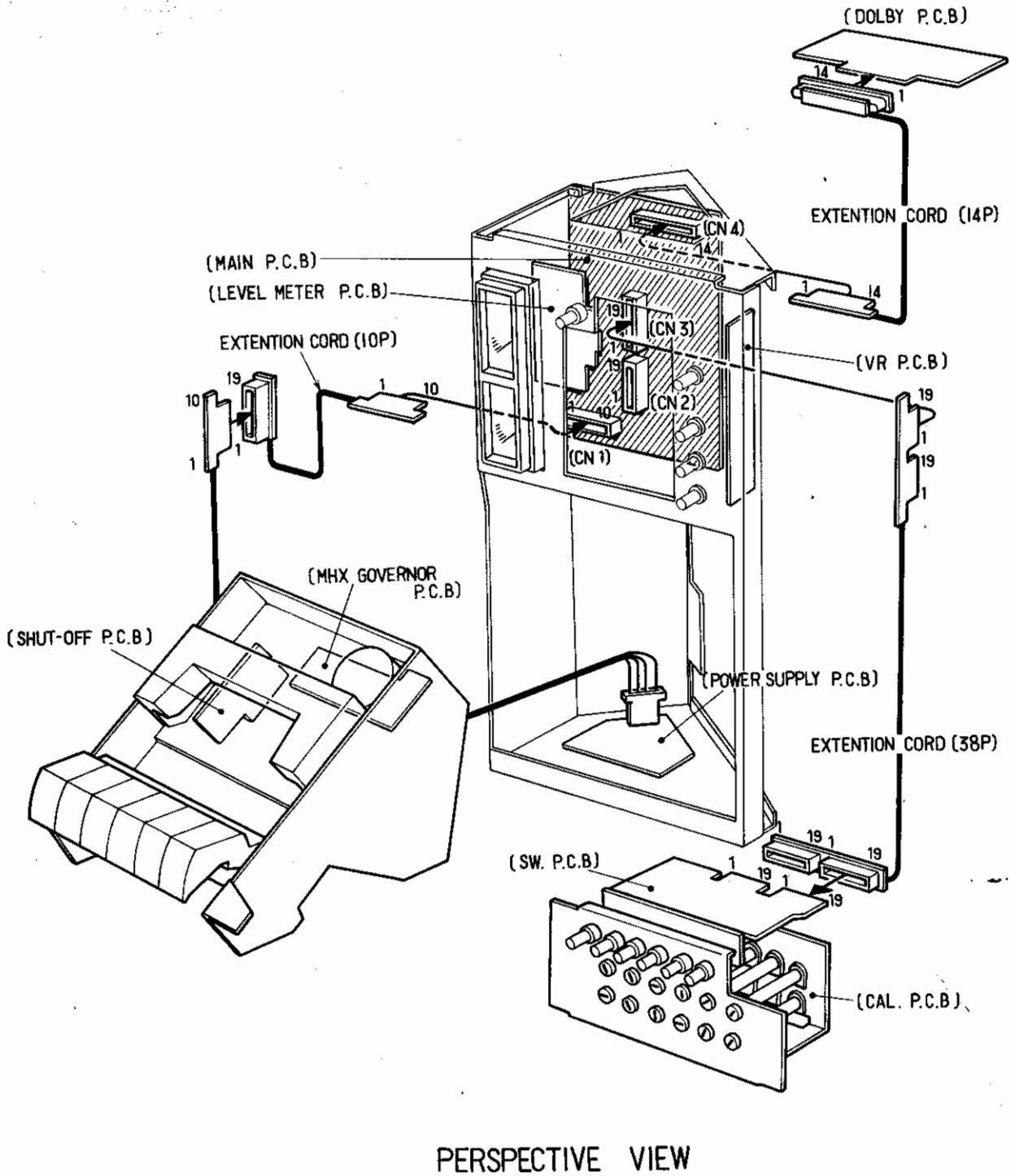

Fig. 4 Extension Cord Connection

5. MECHANICAL ADJUSTMENTS

5.1. Take-up Torque and Rewind Torque Adjustment

To adjust torque, move torque plate as shown in the Fig. 5.1. The take-up torque should be 45 ± 10 g-cm and rewind torque should be 35 to 60g-cm.

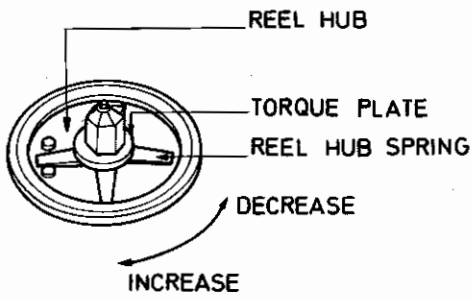

Fig. 5. 1

5.2. Tape Speed Adjustment

- (1) Connect a frequency counter to the output jack.
- (2) Load the 3KHz Speed Wow Flutter Tape (DA-09006A) and play it back.
- (3) Adjust the tape speed adjust potentiometer. See Fig. 5.2.

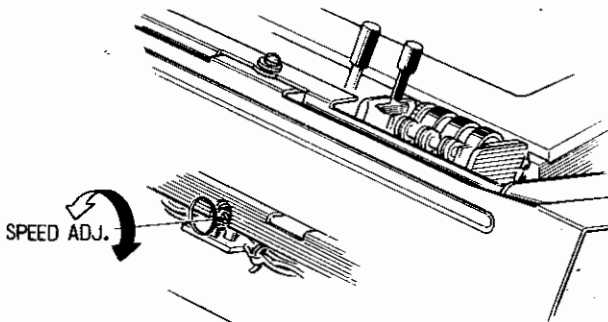

Fig. 5. 2

5.3. Record/Playback Head Height Adjustment and Azimuth Alignment

See Fig. 5.3.

- (1) Load the Track Viwer (DA09012A) and check the positions of record/playback head. Check to insure that the L-R center of head coincides in position with the middle point between two lines (0.3mm distance) on the track viwer.
- (2) If the L-R center deviates from the middle point over 0.2mm. Correct the deviation by adding a head height spacer as illustrated in the item 9.18 (B09).
- (3) Connect a VTVM to output jacks.
- (4) Load the 1KHz Track Alignment Tape (DA09007A). Insert the Tape Guide Adjuster (OD09001A) into each hole of the tape guide beside the head. Adjust the jig for minimizing each output signal of the right and left channels.

- (5) Load the 15KHz Azimuth Tape (DA09004A). Adjust the azimuth alignment screw for maximizing each output signal of the right and left channels. After completion of the adjustment in this step, check the head height as directed in Step (4).

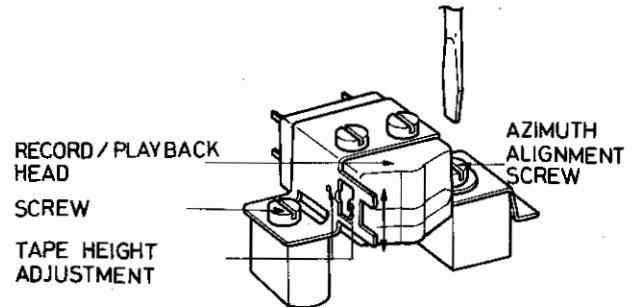

Fig. 5. 3

5.4. Head Base Stroke Adjustment

- (1) Remove the mechanism ass'y referring to the item 3.3, mechanism ass'y removal procedure.
- (2) Adjust the height of head base stroke adjustment plate as illustrated in Fig. 5.4 (Height Adj.).
- (3) Load the "INFORMATION TERMINALS M-300" jig for positioning the record/playback head, pushing backward to eliminate the clearance between reference pin and jig.
- (4) Depress the play button and check to insure whether the positioning of the head is within the specified tolerance. If not, adjust the head base stroke adjustment plate from the bottom side at stop mode. See Fig. 5.4 (Stroke Adj.).

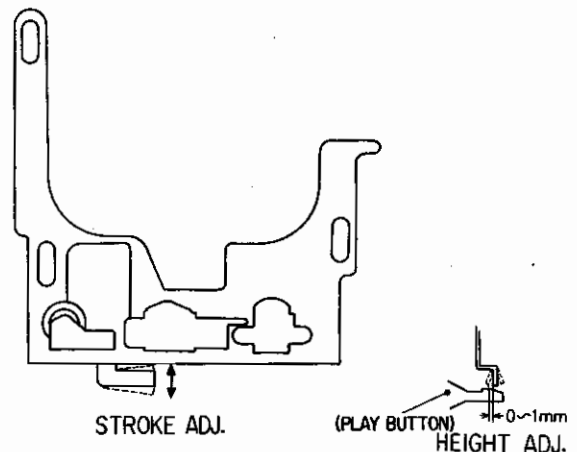

Fig. 5. 4

5.5. Pause Timing Adjustment

This adjustment is required for avoiding the tape spill or tape skip by the inaccurate pause timing.

See Fig. 5.5.

- (1) Set to the playback mode without loading the cassette tape.
- (2) Depressing the pause button gradually, check to insure the gap between pressure roller and capstan shaft which will be approximately 0.1mm when take-up pulley stops rotation because of changing mode from playback to pause.
- (3) In case above is not sufficient, remove the record link ass'y referring to the item 3.16, record link ass'y removal procedure. And adjust the pressure roller as illustrated in the figure.

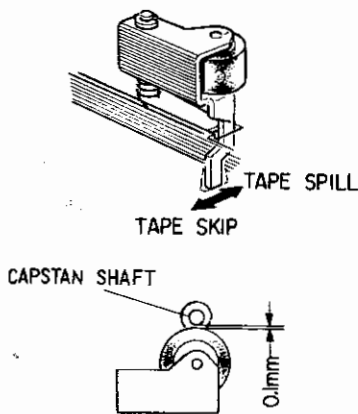

Fig. 5.5

5.6. Belt Travelling Adjustment

Refer to the Fig. 5.6 and item 3.10, motor and motor governor ass'y removal procedure.

- (1) Adjust the motor pulley position and check to insure whether the drive belt is travelling along the correct position and the staying at the correct position, i.e. the center part of motor pulley and the idler pulley without contacting the belt guide at the following modes:
Playback, FF, REW, FF to Stop, REW to Stop
- (2) In case motor pulley is tilting, insert spacers into the A, B (when belt slips upward on the motor pulley) or C (when belt slips downward).

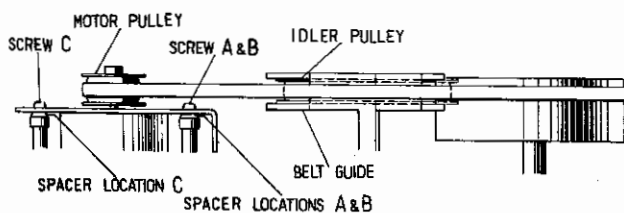

Fig. 5.6

5.7. Flywheel Adjustment

Refer to the Fig. 5.7 and item 3.1, cabinet removal procedure. Adjust the flywheel clearances should be 0.05 to 0.1mm. After adjustment lock the lock nut.

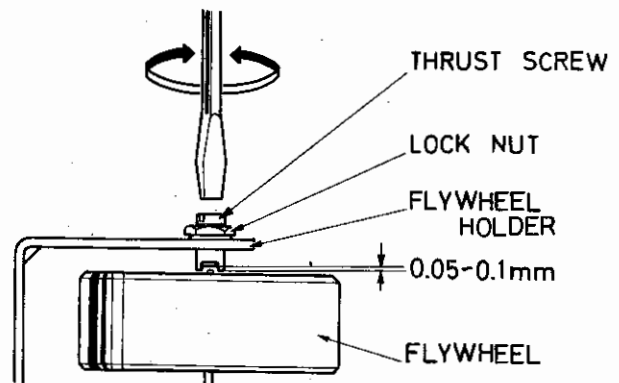

Fig. 5.7

5.8. Brake Timing Adjustment

Remove the cassette case referring to the item 3.5, cassette case ass'y removal procedure.

Refer to the Fig. 5.8.

Loosen screw A, and adjust the contact point between idler pulley and brake to meet each other when control button is depressed and mode is changed from FF to Stop, REW to Stop and Play to Stop.

Fasten screw A and check to insure the gap between idler pulley and brake is approximately within 0.2mm.

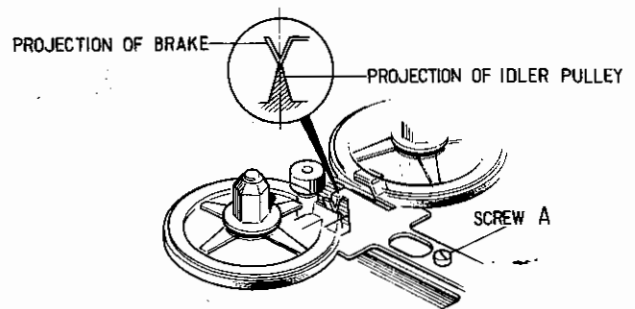

Fig. 5.8

5.9. Mute SW. and Start SW. Timing Adjustment

See Fig. 5.9. Following are each stage of status from stop mode to play mode. Adjust (bend) each transfer to obtain accurate movement.

Item 5.4, head stroke adjustment has to be performed prior to this adjustment.

- (1) Stop
Mute SW. transfer 1-2 is open and start SW. transfers b-c, f-g and d-e are open. Others are close.
- (2) Play Button Depressing Start
Mute SW. transfer 2-3 opens then start SW. transfer a-b will open.
- (3) In the Course of Depressing
Mute SW. transfer 1-2 closes then start SW. transfers b-c and d-e will close.
- (4) Depressing End
Mute SW. transfer 5, 6 will open from 4 simultaneously.
Check to insure the gap between 5, 6 and 4 is more than 0.5mm.
- (5) At stop mode, check to insure the mute SW. transfer 2-3 touches sufficiently.
- (6) Depress the rewind button and check to insure start SW. transfers a-b, d-e and f-g touch sufficiently.
If not, at stop mode bend the A in the figure and adjust the stroke.

5.10. Solenoid Position Adjustment

- (1) Remove the mechanism ass'y referring to the item 3.3, mechanism ass'y removal procedure. See Fig. 5.10.
- (2) Loosen the screw a little and move the solenoid in the A direction.
- (3) Depress the play button.
- (4) Holding the solenoid as shown in the figure, slide the solenoid gradually by a flat screw driver in the B direction.
- (5) Then play button will release. Move the solenoid approximately 0.1 to 0.3mm from the released point in the B direction. Fasten the solenoid.
- (6) Assemble the mechanism ass'y and turn the power switch on. And check to insure whether the solenoid can be released at the Play, FF, REW and Pause modes.

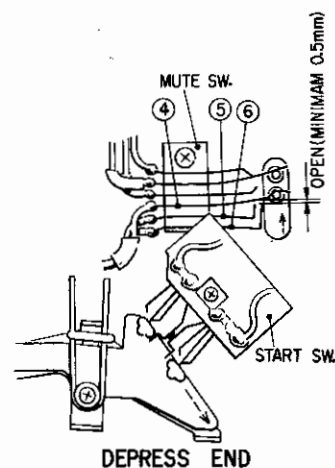
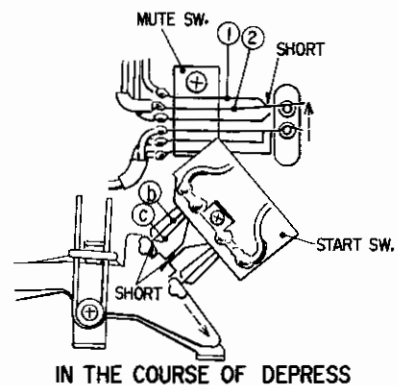
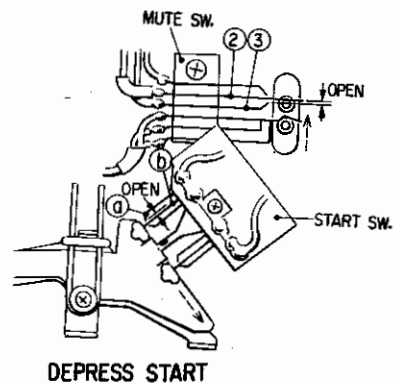
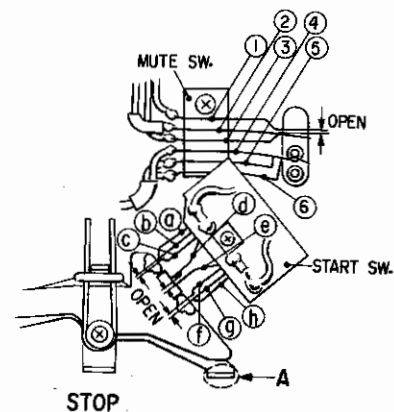

Fig. 5.9

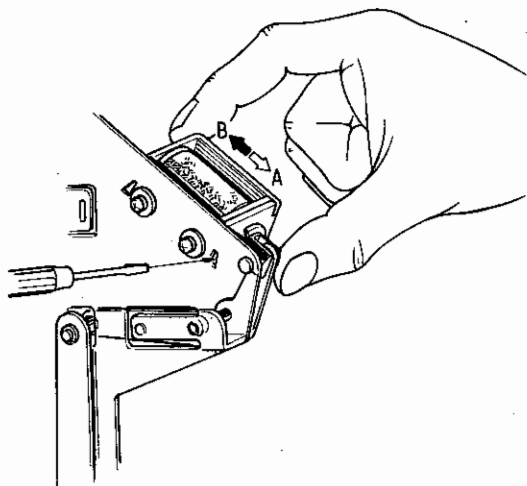

Fig. 5. 10

5. 11. Record Link Adjustment

Remove the cabinet referring to the item 3.1, cabinet removal procedure.
Adjust the record link referring to the Fig. 5.11.

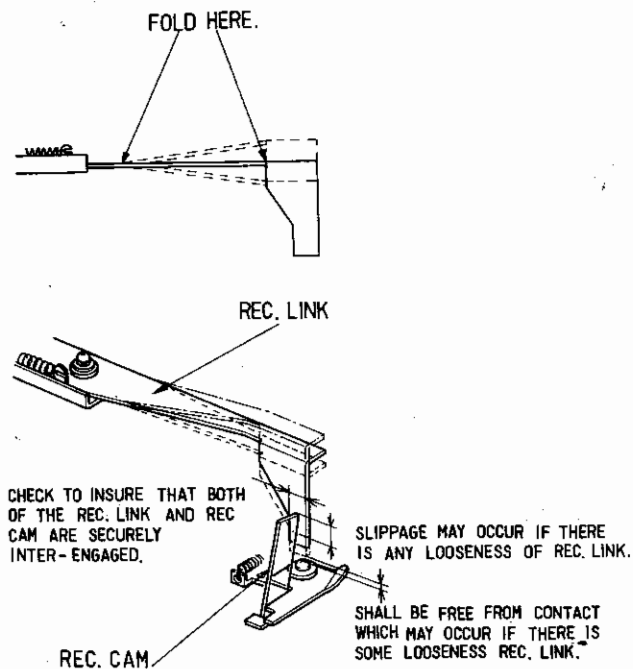

Fig. 5. 11

5. 12. Lubrication

After 500 hours of use apply a few drops of light machine oil (LAUNA No. 40) between capstan and capstan bearing. See Fig. 5.12.

After 500 hours of use apply a few drops of light machine oil (LAUNA No. 40) to the pressure roller shaft.

Note: If the lubrication oil is applied also to the capstan shaft and other drive mechanisms, clean it off with an alcohol-dipped cloth.

When flywheel or flywheel holder is replaced apply a few drops of grease to the flywheel holder.

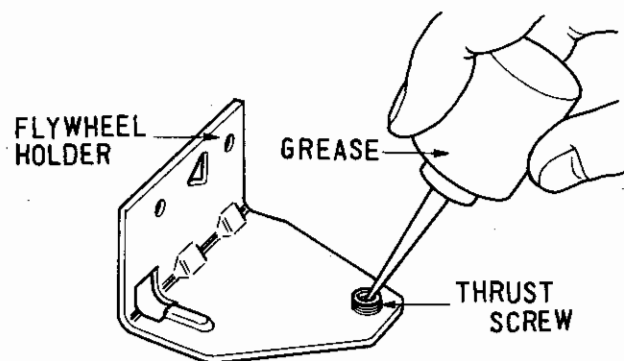
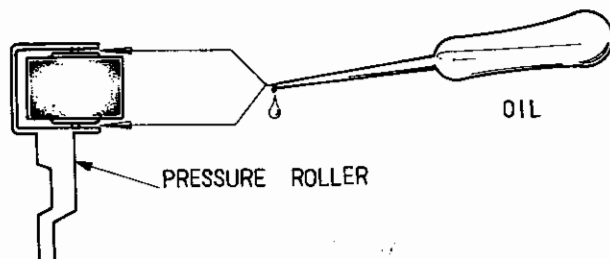
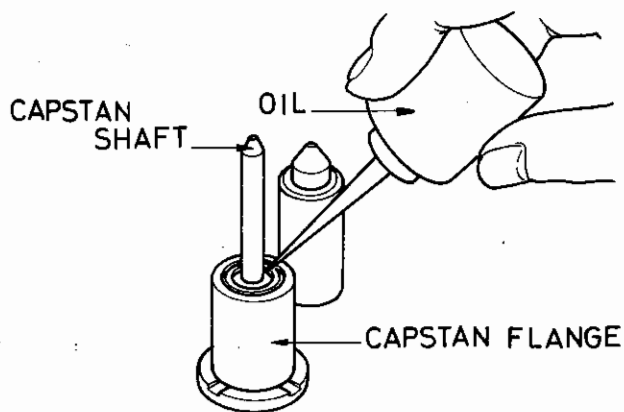

Fig. 5. 12

5.13. Tape Travelling Adjustment

Load the Tape Travelling Cassette (DA09027A) and check the following:

- (1) After more than 2 second when depressed play button, the tolerance of the tape travelling fluctuation on the record/playback head shall not be more than 0.1mm.
- (2) Tape is contact with head sufficiently.
- (3) Tape waving is small (on the head and pressure roller).

If tape travelling is not good, re-adjustment of 5.1. "Take-up Torque and Rewind Torque Adjustment", 5.3. "Reocrd/Playback Head Height Adjustment", 5.4. "Head Base Stroke Adjustment" and others will be required.

STEP	ITEM	SIGNAL SOURCE	OUTPUT CONNECTION	MODE	ADJUSTMENT	REMARKS
1	Tape Speed	3KHz Speed & Wow/Flutter Tape (DA09006A)	Frequency Counter to OUTPUT Jacks	Playback	MHX Motor Governor P.C.B. VR501	Adjust VR501 to obtain 3KHz $\pm 1.5\%$.
2	Tone Calibration	400Hz Test Tone	VTVM to OUTPUT Jacks	Record, Pause 400Hz Tone SW.-On	Main P.C.B. VR301	1. Turn on tone SW. 2. Turn output level control fully clockwise (maximum position). 3. Adjust VR301 to obtain 580mV $\pm 0.3dB$ on the VTVM. Note: If above is not sufficient modification of R150 or R250 on the main P.C.B. will be required.
3	Meter Level	400Hz Test Tone	VTVM to OUTPUT Jacks	Record, Pause 400Hz Tone SW.-On	Meter P.C.B. VR701, VR702	Adjust VR701 (VR702) to obtain 0dB on the level meters.
4	MPX Filter	19KHz $\pm 100Hz$ to INPUT Jacks	VTVM to OUTPUT Jacks	Record Pause MPX SW.-In	Main P.C.B. L103, L203	Adjust the coils to obtain minimum reading on the VTVM.
5	Tape Guide Alignment	1KHz Track Alignment Tape (DA09007A)	VTVM to OUTPUT Jacks	Playback Tape SW.-IX Eq. SW.-70 μs Dolby NR/SW.-Out I.M. Suppress SW.-Out MPX SW.-Out	Tape Guide of Record/Playback Head	Adjust tape guide with Tape Guide Adjuster (DA09001A) to obtain minimum reading of both L and R channels on the VTVM. See item 5.3 "Record/Playback Head Height Adjustment and Azimuth Alignment".
6	Playback Head Azimuth Alignment	15KHz Azimuth Tape (DA09004A)	VTVM to OUTPUT Jacks	Same as above	Azimuth Alignment Screw	Adjust the azimuth alignment screw to obtain maximum reading of both L and R channels on the VTVM. See item 5.3 "Record/Playback Head Height Adjustment and Azimuth Alignment".
7	Playback Level	400Hz Level Tape (DA09005A)	VTVM to OUTPUT Jacks	Same as above	Main P.C.B. VR101, VR201	Adjust the VR101 (VR201) to obtain 580mV on the VTVM or 0dB on the level meters.
8	Adjustment of Hum Balancer	Blank Tape	VTVM to OUTPUT Jacks	Play, Pause Eq. SW.-70 μs Dolby NR/SW.-In MPX SW.-In	Main P.C.B. Hum Balancer (Jumper Wire)	Adjust Hum Balancers to obtain minimum reading of L and R channels on the VTVM.
9	Playback Frequency Response	400Hz Level Tape (DA09005A) 10KHz P.B. Frequency Response Tape (DA09003A) 15KHz P.B. Frequency Response Tape (DA09002A) 20KHz P.B. Frequency Response Tape (DA09001A)	VTVM to OUTPUT Jacks	Playback Tape SW.-IX Eq. SW.-70 μs Dolby NR/SW.-Out I.M. Suppress SW.-Out MPX SW.-Out	Main P.C.B. L101, L201	1. Load the 400Hz level tape and play it back. Adjust the output level controls to a certain level (example 0dB). 2. Load the 10KHz, 15KHz and 20KHz P.B. frequency response tapes and adjust the playback head azimuth to give maximum levels on the VTVM with each tape. 3. Adjust L101, (L201) to obtain the following levels against 400Hz level tape (normally peaking frequency will be adjusted at 23KHz). 10KHz tapes $-20dB \pm 3dB$ 15KHz tapes $-20dB + 3dB, -6dB$ 20KHz tape 4. Conduct step 6 "Playback Head Azimuth Alignment". 5. If above is not sufficient refer to the item 6.2.1. "Playback Frequency Response Adjustment".

Note: When record/playback head is replaced, twist the signal wires (red and white) which are soldered to head terminals for reducing the influence of hum.

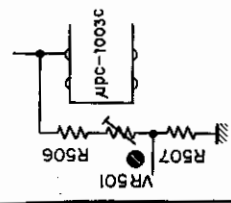

Fig. 6. 1. 1 Tape Speed

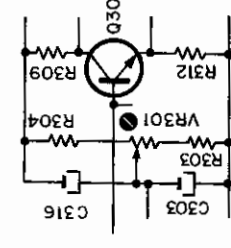

Fig. 6. 1. 2 Tone Calibration

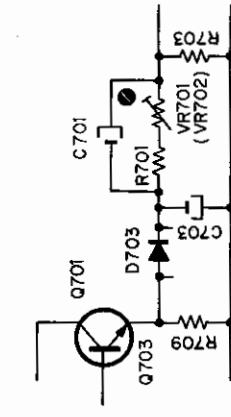

Fig. 6. 1. 3 Meter Level

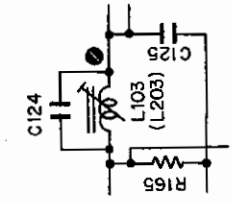

Fig. 6. 1. 4 MPX Filter

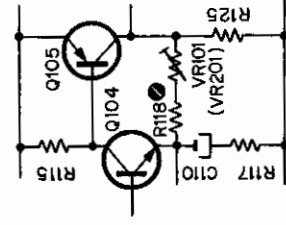

Fig. 6. 1. 5 Playback Level

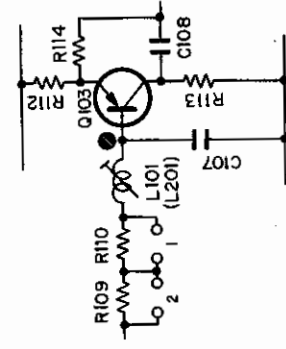
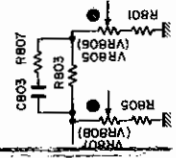
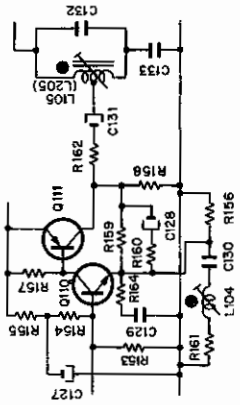
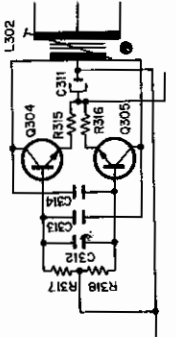

Fig. 6. 1. 6 Playback Frequency Response

STEP	ITEM	SIGNAL SOURCE	OUTPUT CONNECTION	MODE	ADJUSTMENT	REMARKS
10	Bias Oscillation Frequency		Coupling Bias Oscillator signal (Main P.C.B. CN1-4) to Frequency Counter	Record, Pause	Main P.C.B. L302	Adjust the coil to obtain 105KHz on the frequency counter.
11	Record Amplifier Equalizer	INPUT Jacks 23KHz (-20dB) to INPUT Jacks	VTVM to Main P.C.B. Test Pin TP-L, TP-R	Record, Pause Tape SW.-SX Eq. SW.-70µs Dolby NR SW.-Out I.M. Suppress SW.-Out MPX SW.-Out	Main P.C.B. L104, L204	1. Remove the bias-cut-jumper from the dip side of the main P.C.B. 2. Adjust the coils to obtain peak readings at 23KHz. 3. Resolder bias-cut-jumper.
12	Bias Trap	Remove Input Signals	Same as above	Same as above	Main P.C.B. L105, 205	Adjust the coils to obtain maximum reading on the VTVM.
13	Record Level Calibration	400Hz Test Tone or 400Hz to INPUT Jacks	VTVM to OUTPUT Jacks	Record & Playback Tape SW.-EX/SX Eq. SW.-120µs (EX) x L I - 70µs (SX) Dolby NR SW.-Out I.M. Suppress SW.-Out MPX SW.-Out	CAL. P.C.B. VR805, VR806, VR807, VR808 (Front Panel Level Semi-fixed Volume)	1. Record the signals on the Reference EX11 Tape (DA090021A) or Reference SX Tape (DA090025A) and play it back. 2. Repeating 1 as above, adjust VR805 (VR806) (for EX11) and VR807 (VR808) (for SX) to obtain 0dB on the level meters in playback mode.
14	Recording Bias Current & Record/Playback Level	400Hz Test Tone or 400Hz to INPUT Jacks & 40Hz to 18KHz (-20dB) to INPUT Jacks	VTVM and Distortion Meter to OUTPUT Jacks	Same as above	CAL. P.C.B. VR801, VR802, VR803, VR804 (Front Panel Bias Semi-fixed Volume)	1. Feed in 400Hz and adjust input level controls to obtain 0dB on the level meters. 2. Record the signals on the reference EX11 tape (DA09021A) or SX tape (DA09025A). 3. Repeating 2 as above, play back the tape and adjust VR801 (VR802) (for EX11) or VR803 (VR804) (for SX) to obtain maximum reading on the VTVM. 4. Conduct step 13 "Record Level Calibration". 5. Feed in 10KHz (-20dB) and record and play it back. Adjust VR801 (VR802) (for EX11) or VR803 (VR804) (for SX) to obtain approximately -20dB on the VTVM. Then feed in 18KHz (-20dB) and record and play it back. Adjust recording peaking coils L104 (L204) to obtain approximately -20dB on the VTVM (refer to the step 11 "Record Amplifier Equalizer"). 6. Conduct step 13 "Record Level Calibration". 7. Feed in 400Hz and adjust the input level controls to obtain 0dB on the level meter, then record and play it back and check whether the Total Harmonic Distortion (T.H.D.) is less than 1.5%. Feed in 40Hz to 18KHz (-20dB) and record and play it back, and check to insure if the output level is within -20dB ±3dB. 8. If T.H.D. exceeds 1.5%, the following adjustments are required. a. Repeat 5 as above. Adjust bias semi-fixed volumes and peaking coils to obtain -22dB instead of -20dB on the VTVM. b. Perform step 13 "Record Level Calibration". c. Repeat 7 as above. d. If above is not sufficient, precise readjustment of step 9 "Playback Frequency Response" or replacement of record/playback Head or check of the item 5.13 "Tape Travelling Adjustment" will be required. 9. Conduct step 13 "Record Level Calibration".

6-1-10
Recording Bias Current
& Record/Playback
Level

6-1-19 Record Level
Calibration



P 21

Fig 6.1.7 Bias Osc. Frequency

6-1-8 Rectifier Eq., Bias Trap

6-1-19 Record Level
Calibration

STEP	ITEM	SIGNAL SOURCE	OUTPUT CONNECTION	MODE	ADJUSTMENT	REMARKS
15	I.M. Suppress	400Hz Test Tone or 400Hz to INPUT Jacks	VTVM and Distortion Meter to OUTPUT Jacks	Record & Playback Tape SW: EX/SX Eq. SW: 20μs (EX) 70μs (SX) Dolby NR SW: -In I.M. Suppress SW: -In MPX SW: -In	CAL. P.C.B. VR809, VR810, VR811, VR812 (Front Panel I.M. Suppress Semi-fixed Volume)	1. Record the signals on the reference EX II tape or SX tape. 2. Adjust VR809 (VR810) for EX(II) and VR811 (VR812) for SX to obtain minimum total harmonic distortion at playback mode. Note: In case semi-fixed volume is turned fully counter-clockwise, leave the volume at that position.
16	Dolby Circuit	5KHz to INPUT Jacks	VTVM to Dolby P.C.B. Connector Terminal	Record, Erase MPX SW: -In	Dolby P.C.B. VR101, 102, VR201, 202	Adjust only if board is repaired. 1. Remove the bias-cut-jumper from the dip side of main P.C.B. 2. Turn LAW Control VR101, 201 fully counter-clockwise. 3. Turn GAIN Control VR102, 202 fully counter-clockwise. 4. Set Colby NR Switch to Out position and short Test Pin TP101, 201 to ground. 5. Connect a VTVM to Metering Terminal 3 for the Right channel or 12 for the Left channel. 6. Apply 5KHz signals having a proper level to INPUT so that the VTVM may read 17.5mV at each channel. 7. Remove the VTVM from Terminal 3 or 12 and re-connect it to OUTPUT Terminal 6 or 9. Note the output voltage on VTVM. 8. Set Dolby NR Switch to In position and adjust GAIN Controls VR102 and 202, till the VTVM indicates 10dB over the noted voltage in 6 as above. 9. Set Dolby NR Switch to In position. Note the voltage at OUTPUT Terminal 6 for the Right channel or 9 for the Left channel. 10. Remove TP101, 201 short and adjust LAW Control VR101, 201 for 2dB drop in the voltage at OUTPUT Terminal. 11. Resolder the bias-cut-jumper.
17	Crosstalk	1KHz to INPUT Jacks	1KHz Band Pass Filter, VTVM to OUTPUT Jacks	Record & Playback Tape SW: SX Eq. SW: 20μs Dolby NR: SW-Out I.M. Suppress SW: -Out MPX SW: -In		1. Erase the tape with bulk eraser. 2. Adjust input level controls to obtain 0dB on the level meters, and record the signals on the reference tape. 3. Turn the cassette tape the other way round and play it back. 4. Measure the difference between 2 and 3.
18	Channel Separation	1KHz to INPUT Jacks	Same as above	Same as above		1. Erase the tape with bulk eraser. 2. Adjust Lch (Rich) input level control to obtain 0dB on the level meter, and close Rich (Lch) input level control. 3. Record and play it back, then measure the Rich (Lch) level.

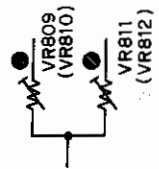

Fig. 6. 1. 11 I.M. Suppress

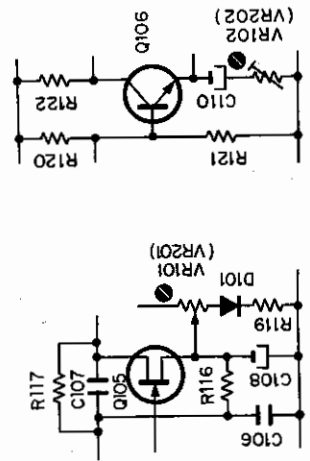

Fig. 6. 1. 12 Dolby Circuit

P22

19	Erase	1K-Hz to INPUT Jacks	1KHz Band Pass Filter, VTVM to OUTPUT Jacks	Record & Playback Tape SW.-SX Eq. SW.-70µs Dolby NR SW.-Out I.M. Suppress SW.-Out MPX SW.-In	1. Erase the tape with bulk eraser. 2. Adjust input level controls to obtain 0dB on the level meters, and record the signals on the reference tape. 3. Rewind the Tape then close input level controls. 4. Record and play it back, then measure the difference between 1 and 2.
20	Signal to Noise Ratio	400Hz to INPUT Jacks	VTVM and Distortion Meter to OUTPUT Jacks	Record & Playback Tape SW.-SX Eq. SW.-70µs Dolby NR SW.-In I.M. Suppress SW.-In MPX SW.-In	1. Feed in 400Hz and record, and play it back. 2. Adjust the input level controls to obtain 3% total harmonic distortion in playback mode. 3. Close the input level controls then record. 4. After reword, play back and check to the output level difference between 2 and 3. Note: The filter of CCITT curve shall be used in the measurements.
21	Total Harmonic Distortion	400Hz to INPUT Jacks	Distortion Meter to OUTPUT Jacks	Record & Playback Tape SW.-EX/SX Eq. SW.-120µs (EX) 70µs (SX) Dolby NR SW.-Out I.M. Suppress SW.-Out MPX SW.-In	1. Adjust input level controls to obtain 0dB on the level meters. 2. Record and play it back. 3. Read the distortion meter.
22	Wow/Flutter	3K-Hz Speed & Wow/Flutter Tape (DA09006A)	Wow/Flutter Meter to OUTPUT Jacks	Playback	Playback and read the wow/flutter meter.

6.2. Frequency Response Adjustment

6.2.1. Playback Frequency Response Adjustment

Fig. 6.2.1 shows the playback equalization curve for Nakamichi 600, and Fig. 6.2.2 is the circuit for adjustment.

(1) Level Adjustment (for middle frequency response):

This adjustment will be required when playback level is not sufficient at 10KHz P.B. Frequency Response Tape (refer to the item 6.1.9.).
Playback equalization level can be varied by the modification of R102 (R202).

Following are the details for level modification:

About +2dB R102 (R202) to 1.5K

About +1dB R102 (R202) to 1.2K

0dB R102 (R202) 1K

About -1dB R102 (R202) to 820ohm

(2) Peaking Adjustment (for high frequency response):

This adjustment will be required when playback level is not sufficient at 20KHz P.B. Frequency Response Tape (refer to the item 6.1.9.).

Peaking portion compensates the air gap loss of the playback head. Peaking frequency is varied by the coil L101 (L201) and peaking level is varied by the short circuit of R109 (R209) or R110 (R210) as illustrated in the figure.

6.2.2. Record Current Frequency Response Adjustment

Record Eq. peaking is adjusted for compensating the overall frequency response when playback frequency response is completed.

Normally however peaking frequency is pre-adjusted to 23KHz in record mode.

See Fig. 6.2.3.

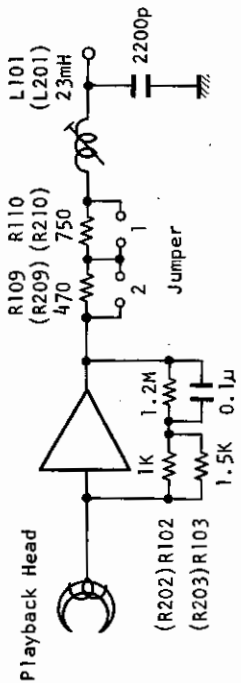

Fig. 6.2.2

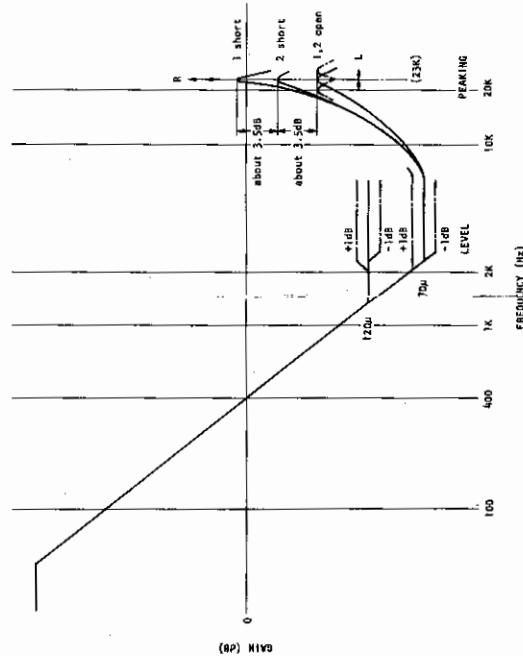

Fig. 6.2.1 Playback Equalizer

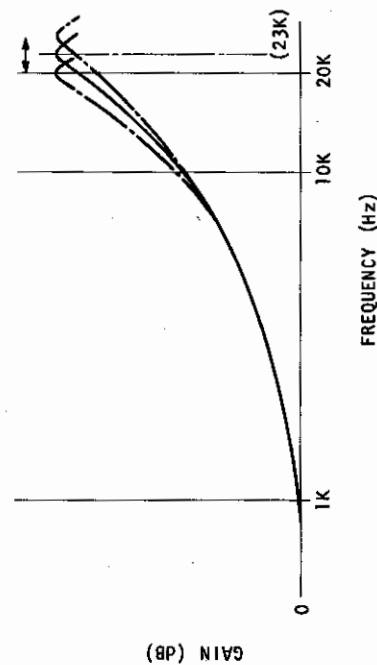

Fig. 6.2.3 Record Eq. Peaking

p 23

7. PARTS LOCATION FOR ELECTRICAL ADJUSTMENT

Note: For adjustment, removal of meter ass'y is required (see item 3.18 meter ass'y removal procedure). When re-adjustment of Dolby P.C.B. Ass'y is required, remove the main P.C.B. from chassis (see item 3.14 main P.C.B. removal procedures).

When a check is made on Amp. etc. by means of an extension cord, re-adjustment shall be made without fail (after final installation to the model chassis.) The check without removal of an extension cord will cause inaccurate adjustments.

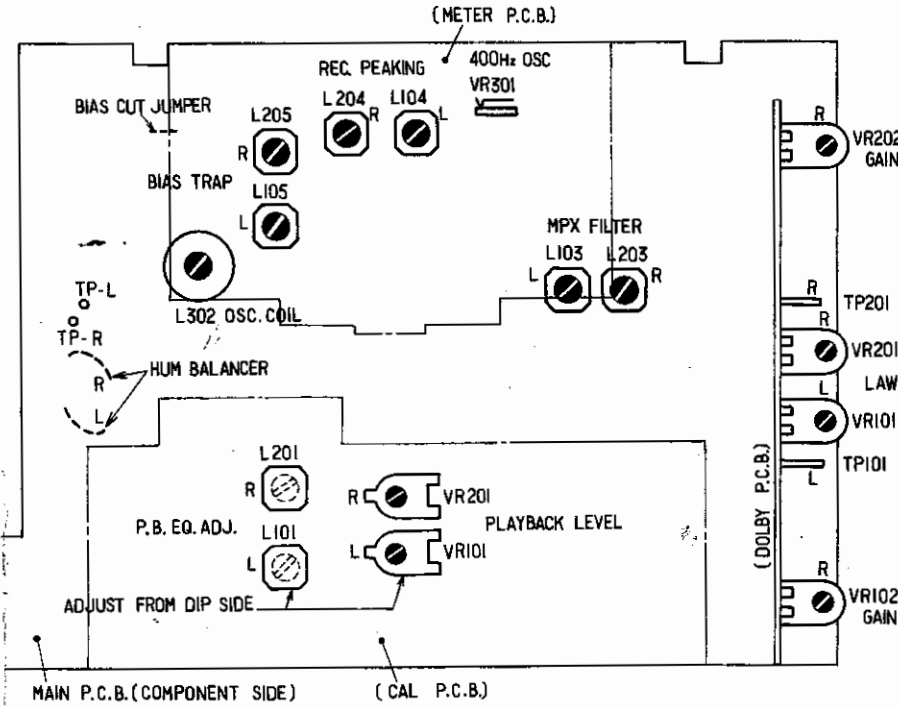

FRONT VIEW

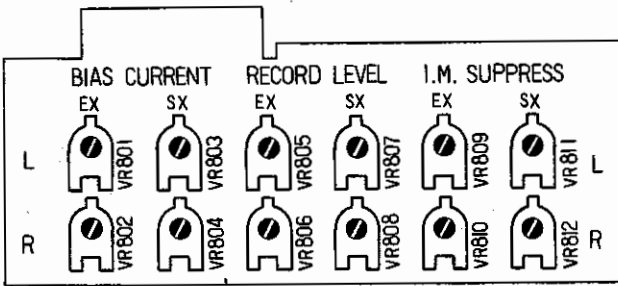

CAL P.C.B. (COMPONENT SIDE)

FRONT VIEW

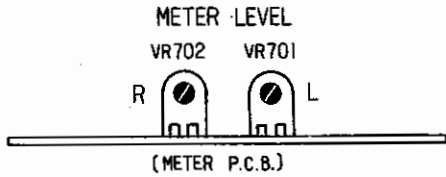

REAR VIEW

Fig. 7

1222 (2)

1733 (L)

555

nH
27
1K
1 ELR% J

K ELR% J

1K ELR% J

1K ELR% J

1M ELR% J

1K ELR% J

1K ELR% J

1 ELR% J

1 ELR% J

1K ELR% J

1K ELR% J

1K ELR% J

1 ELR% J

1K ELR% J

1K ELR% J

1 ELR% J

1K ELR% J

1K ELR% J

1K ELR% J

1K ELR% J

1K ELR% J

1K ELR% J

1M ELR% J

1K ELR% J

1K ELR% J

1M ELR% J

1μ 16V

1P 50V

1μ 50V J

1μ 16V

1μ 16V

1P 50V J

1P 50V J

MOUNTING DIAGRAM & PARTS LIST

te: Mounting diagram shows a dip side view of the printed circuit board.

1. Main P.C.B. Ass'y

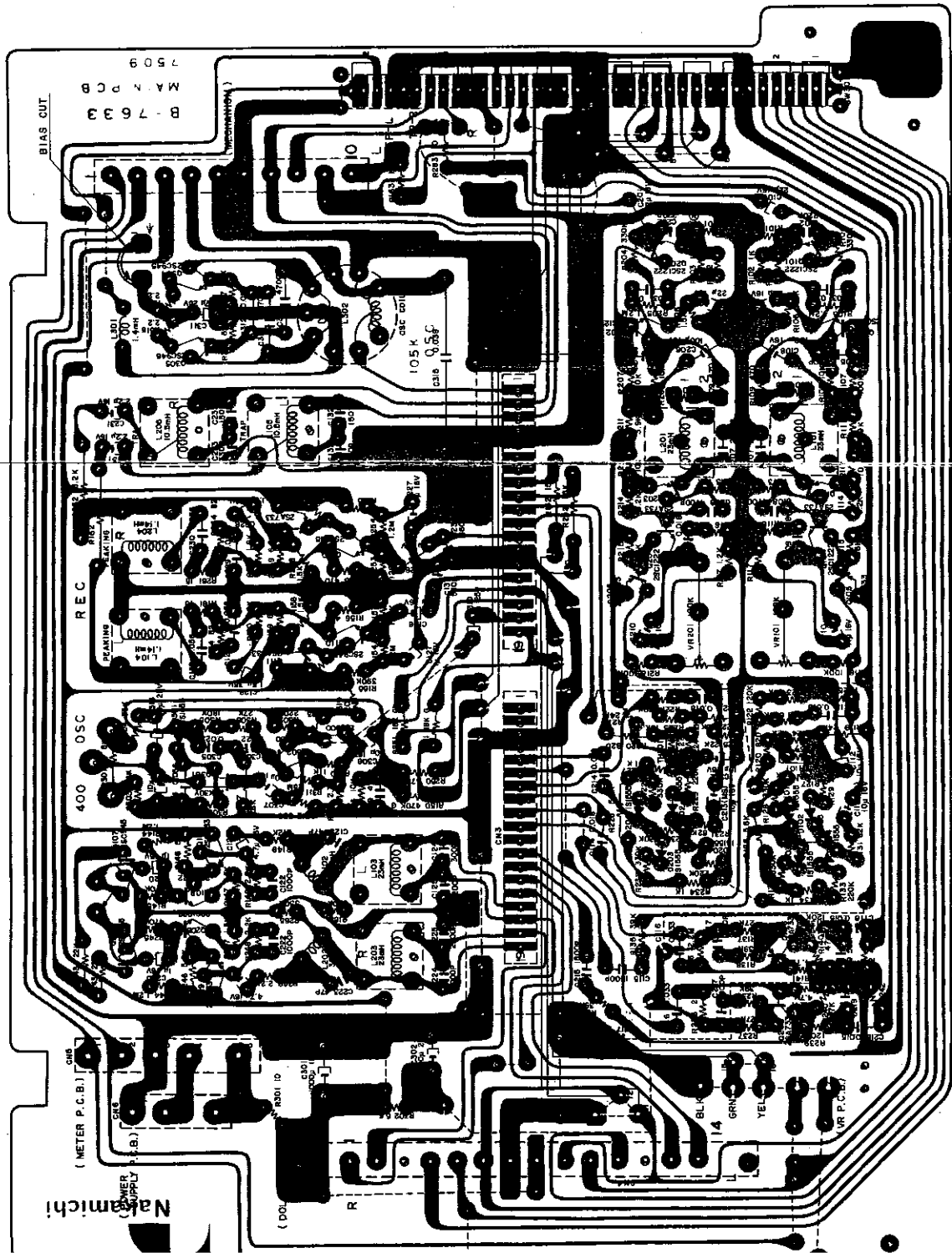

Fig. 8. 1

P 25

Schematic Ref. No.	Part No.	Description
	BA03715A	Main P.C.B. Ass'y
		- P.B. Eq. Amp. -
Q101, 201	0806062A	Transistor 25C1222 (2)
102, 202		
104, 204		
Q103, 203	0806013A	Transistor 25A733 (L)
105, 205		
106, 206		
D101, 201	0801909A	Silicon Diode 1S1555
102, 202		
103, 203		
104, 204		
L101, 201	0803857A	19KHz Coil 23mH
TH101, 201	0801897A	Thermistor 5B-27
VR101, 201	0801812A	Semi-fixed Volume 100K
R101, 201	0805633A	Carbon Resistor 100 ELR% J, Noiseless
R102, 202	0801781A	Carbon Resistor 1K ELR% J
127, 227		
134, 234		
R103, 203	0805605A	Carbon Resistor 1.5K ELR% J
106, 206		
R104, 204	0801921A	Carbon Resistor 330K ELR% J
128, 228		
130, 230		
132, 232		
R105, 205	0805637A	Carbon Resistor 1.2M ELR% J
R107, 207	0801920A	Carbon Resistor 100K ELR% J
118, 218		
R108, 208	0801833A	Carbon Resistor 10K ELR% J
112, 212		
113, 213		
123, 223		
R109, 209	0801792A	Carbon Resistor 470 ELR% J
R110, 210	0805635A	Carbon Resistor 750 ELR% J
R111, 211	0805664A	Carbon Resistor 3.9K ELR% J
R114, 214	0801878A	Carbon Resistor 8.2K ELR% J
R115, 215	0805663A	Carbon Resistor 56K ELR% J
R116, 216	0805606A	Carbon Resistor 22 ELR% J
R117, 217	0805665A	Carbon Resistor 1.2K ELR% J
124, 224		
R119, 219	0801832A	Carbon Resistor 24K ELR% J
R120, 220	0805511A	Carbon Resistor 820 ELR% J
R121, 221	0805665A	Carbon Resistor 560K ELR% J
R122, 222	0805669A	Carbon Resistor 120K ELR% J
139, 239		
R125, 225	0805661A	Carbon Resistor 22K ELR% J
R126, 226	0805673A	Carbon Resistor 5.6K ELR% J
R129, 229	0805596A	Carbon Resistor 220K ELR% J
133, 233		
R131, 231	0801564A	Carbon Resistor 82K ELR% J
R135, 235	0801885A	Carbon Resistor 39K ELR% J
138, 238		
R136, 236	0805672A	Carbon Resistor 2.2M ELR% J
R137, 237	0805538A	Carbon Resistor 27K ELR% J
R140, 240	0805562A	Carbon Resistor 47K ELR% J
142, 242		
R141, 241	0805824A	Carbon Resistor 4.7M ELR% J
C101, 201	0805636A	Tantalum Capacitor 22μ 16V
C102, 202	0801289A	Ceramic Capacitor 220P 50V
105, 205		
C103, 203	0801780A	Mylar Capacitor 0.1μ 50V J
C104, 204	0801862A	Electrolytic Capacitor 22μ 16V
C106, 206	0801400A	Electrolytic Capacitor 100μ 16V
C107, 207	0801802A	Mylar Capacitor 2200P 50V J
C108, 208	0805652A	Mylar Capacitor 4700P 50V J

1. MOUNTING DIAGRAM & PARTS LIST

Note: Mounting diagram shows a dip side view of the printed circuit board.

21. Main P.C.B. Ass'y

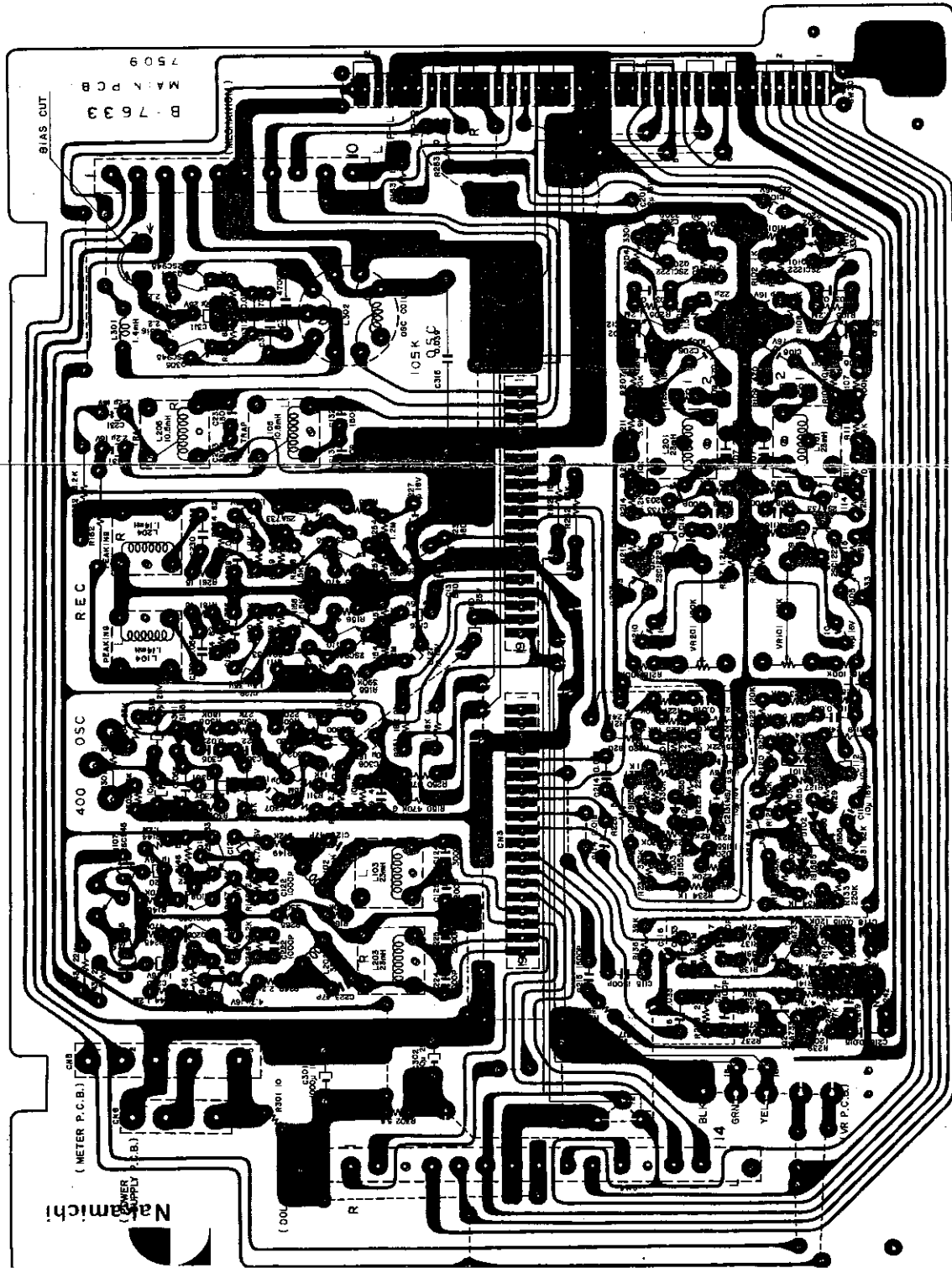

Fig. 8. 1

25

Schematic Ref. No.	Part No.	Description
Q101, 201	BA03715A	Main P.C.B. Ass'y
102, 202	- P.B. Eq. Amp. -	
104, 204	0B06062A	Transistor
105, 205	0B06013A	Transistor
D101, 201	0B01909A	Silicon Diode
103, 203	0B03857A	19KHz Coil
104, 204	0B01897A	Thermistor
L101, 201	0B01812A	Semi-fixed Volume
TR101, 201	0B05833A	Carbon Resistor Noiseless
R101, 201	0B01781A	Carbon Resistor 1K ELR $\frac{1}{2}$ J
R102, 202	127, 227	
134, 234	0B05505A	Carbon Resistor 1.5K ELR $\frac{1}{2}$ J
R103, 203	0B01921A	Carbon Resistor 330K ELR $\frac{1}{2}$ J
106, 206		
R104, 204	128, 228	
130, 230	132, 232	
R105, 205	0B05537A	Carbon Resistor 1.2M ELR $\frac{1}{2}$ J
R107, 207	0B01920A	Carbon Resistor 100K ELR $\frac{1}{2}$ J
118, 218		
R108, 208	0B01833A	Carbon Resistor 10K ELR $\frac{1}{2}$ J
112, 212		
113, 213		
123, 223		
R109, 209	0B01792A	Carbon Resistor 470 ELR $\frac{1}{2}$ J
R110, 210	0B05835A	Carbon Resistor 750 ELR $\frac{1}{2}$ J
R111, 211	0B05664A	Carbon Resistor 3.9K ELR $\frac{1}{2}$ J
R114, 214	0B01878A	Carbon Resistor 8.2K ELR $\frac{1}{2}$ J
R115, 215	0B05563A	Carbon Resistor 56K ELR $\frac{1}{2}$ J
R116, 216	0B05606A	Carbon Resistor 22 ELR $\frac{1}{2}$ J
R117, 217	0B05565A	Carbon Resistor 1.2K ELR $\frac{1}{2}$ J
124, 224		
R119, 219	0B01832A	Carbon Resistor 24K ELR $\frac{1}{2}$ J
R120, 220	0B05511A	Carbon Resistor 820 ELR $\frac{1}{2}$ J
R121, 221	0B05665A	Carbon Resistor 560K ELR $\frac{1}{2}$ J
R122, 222	0B05568A	Carbon Resistor 120K ELR $\frac{1}{2}$ J
139, 239		
R125, 225	0B05661A	Carbon Resistor 22K ELR $\frac{1}{2}$ J
R126, 226	0B05673A	Carbon Resistor 5.6K ELR $\frac{1}{2}$ J
R129, 229	0B05596A	Carbon Resistor 220K ELR $\frac{1}{2}$ J
133, 233		
R131, 231	0B01564A	Carbon Resistor 82K ELR $\frac{1}{2}$ J
R135, 235	0B01885A	Carbon Resistor 39K ELR $\frac{1}{2}$ J
138, 238		
R136, 236	0B05672A	Carbon Resistor 2.2M ELR $\frac{1}{2}$ J
R137, 237	0B05538A	Carbon Resistor 27K ELR $\frac{1}{2}$ J
R140, 240	0B05562A	Carbon Resistor 47K ELR $\frac{1}{2}$ J
142, 242		
R141, 241	0B05824A	Carbon Resistor 4.7M ELR $\frac{1}{2}$ J
C101, 201	0B05636A	Tantalum Capacitor 22 μ 16V
C102, 202	0B01289A	Ceramic Capacitor 220P 50V
105, 205		
C103, 203	0B01780A	Mylar Capacitor 0.1 μ 50V J
C104, 204	0B01862A	Electrolytic Capacitor 22 μ 16V
C106, 206	0B01400A	Electrolytic Capacitor 100 μ 16V
C107, 207	0B01807A	Mylar Capacitor 2200P 50V J
C108, 208	0B05652A	Mylar Capacitor 4700P 50V J

Schematic Ref. No.	Part No.	Description	Schematic Ref. No.	Part No.	Description
C109, 209 111, 211 114, 214	OB05832A	Mylar Capacitor 0.018 μ 50V J	OB05512A	C131, 231	Electrolytic Capacitor 2.2 μ 16V
C110, 210	OB01403A	Electrolytic Capacitor 47 μ 16V	OB05829A	C132, 232	SP Capacitor 150P 50V J
C112, 212	OB01412A	Electrolytic Capacitor 10 μ 16V	OB05611A	C133, 233	SP Capacitor 330P 35V J
C113, 213	OB05840A	Electrolytic Capacitor 10 μ 16V M (MS)	OB05686A	C134, 234	Mylar Capacitor 560P 50V
C115, 215	OB05653A	Mylar Capacitor 1500P 50V J		- 400Hz Osc. -	
C116, 216	OB05583A	Mylar Capacitor 0.033 μ 50V J	Q301	OB01600A	FET 2SK30A (Y)
C117, 217	OB01913A	Mylar Capacitor 1800P 50V J	Q302, 303	OB01910A	Transistor 2SC900 (E)
C118, 218	OB05557A	Mylar Capacitor 0.015 μ 50V J	D301	OB01909A	Silicon Diode 1S1555
C119, 219	OB05788A	SP Capacitor 560P 50V J	VR301	OB01470A	Semi-fixed Volume 5K
	JA03033A	Noise Shield (A) Ass'y (2 pcs. for L101, 201)	R303	OB05673A	Carbon Resistor 5.6K ELR% J
	- Line Amp. -		R304	OB01879A	Carbon Resistor 33K ELR% J
Q107, 207	OB01872A	Transistor 2SC945 (L)	R305	OB05669A	Carbon Resistor 180K ELR% J
Q108, 208	OB06062A	Transistor 2SC1222 (2)	R306	OB05775A	Carbon Resistor 3.3M ELR% J
Q109, 209	OB06013A	Transistor 2SA733 (L)	R307	OB01830A	Carbon Resistor 1.8K ELR% J
L102, 202	OB03919A	Inductor 36mH	R308	OB05538A	Carbon Resistor 27K ELR% J
L103, 203	OB03563A	19KHz Coil 23mH	R309	OB05596A	Carbon Resistor 220K ELR% J
R143, 243	OB05661A	Carbon Resistor 22K ELR% J	R310	OB05826A	Carbon Resistor 11K ELR% J
R144, 244	OB05537A	Carbon Resistor 1.2M ELR% J	R311	OB05601A	Carbon Resistor 1.5M ELR% J
R145, 245	OB05700A	Carbon Resistor 470K ELR% J	R312	OB01789A	Carbon Resistor 330 ELR% J
R146, 246	OB05673A	Carbon Resistor 5.6K ELR% J	R313	OB01782A	Carbon Resistor 2.7K ELR% J
R147, 247	OB05505A	Carbon Resistor 1.5K ELR% J	R314	OB01833A	Carbon Resistor 10K ELR% J
R148, 248	OB05566A	Carbon Resistor 2.2K ELR% J	R319	OB05608A	Carbon Resistor 220 ELR% J
149, 249			C303, 307	OB01412A	Electrolytic Capacitor 10 μ 16V
R150, 250	OB05827A	Carbon Resistor 470K RD% G	308		
R151, 251	OB05834A	Carbon Resistor 18K RD% G	C304	OB05778A	Mylar Capacitor 0.056 μ 50V K
R165, 265	OB01921A	Carbon Resistor 330K ELR% J	C305, 306	OB01916A	Mylar Capacitor 0.022 μ 50V J
C120, 220	OB01405A	Electrolytic Capacitor 1 μ 16V	C309	OB01716A	Ceramic Capacitor 470P 50V
C121, 221	OB01389A	Electrolytic Capacitor 4.7 μ 16V	C310	OB01173A	Electrolytic Capacitor 1 μ 25V
C122, 222	OB05550A	Mylar Capacitor 1000P 50V J	C316	OB01674A	Electrolytic Capacitor 10 μ 25V
C123, 223	OB05789A	SP Capacitor 47P 50V J		- Bias Osc. -	
C124, 224	OB05828A	SP Capacitor 3000P 50V J	Q304, 305	OB01872A	Transistor 2SC945 (L)
C125, 225	OB01802A	Mylar Capacitor 2200P 50V J	L301	OB03861A	Trap Coil 1.4mH
	- Rec. Amp. -		L302	OB06536A	Osc. Coil
Q110, 210	OB01872A	Transistor 2SC945 (L)	R315, 316	OB05605A	Carbon Resistor 2.2 ELR% J
Q111, 211	OB06013A	Transistor 2SA733 (L)	R317, 318	OB01564A	Carbon Resistor 82K ELR% J
L104, 204	OB01434A	Peaking Coil 1.14mH	C311	OB01402A	Electrolytic Capacitor 4.7 μ 25V
L105, 205	OB00068A	Bias Trap Coil 10.5mH	C312	OB05813A	Mylar Capacitor 0.056 μ 50V J
R152, 252	OB05591A	Carbon Resistor 15K ELR% J	C313, 314	OB05652A	Mylar Capacitor 4700P 50V J
R153, 253	OB05568A	Carbon Resistor 120K ELR% J	C315	OB05799A	SP Capacitor 0.039 μ 50V J
R154, 254	OB05537A	Carbon Resistor 1.2M ELR% J		- Miscellaneous -	
R155, 255	OB05595A	Carbon Resistor 390K ELR% J	OB07633A	Main P.C.B.	
R156, 256	OB01792A	Carbon Resistor 470 ELR% J	R301	OB05663A	Carbon Resistor 10 ELR% J
R157, 257	OB01793A	Carbon Resistor 3.3K ELR% J	R302	OB05818A	Carbon Resistor 5.6 ELR% J
R158, 258	OB05505A	Carbon Resistor 1.5K ELR% J	C301	OB01673A	Electrolytic Capacitor 1000 μ 18V
R159, 259	OB01877A	Carbon Resistor 6.8K ELR% J	C302	OB05793A	Electrolytic Capacitor 330 μ 25V
R160, 260	OB01830A	Carbon Resistor 1.8K ELR% J	C317	OB04060A	Mylar Capacitor 2200P 50V K
R161, 261	OB05830A	Carbon Resistor 15 ELR% J	SW301	OB07036A	Record Switch
R162, 262	OB01856A	Carbon Resistor 8.2K R% J	CN1	BA03703A	10P Connector Ass'y
R163, 263	OB05663A	Carbon Resistor 10 ELR% J	CN2, 3	BA03562A	19P Connector Sub Ass'y
R164, 264	OB05503A	Carbon Resistor 82 ELR% J	CN4	BA03702A	14P Connector Ass'y
C126, 226	OB01405A	Electrolytic Capacitor 1 μ 16V	CN5	OB08140A	5P Plug
127, 227			CN6	OB08156A	3P Plug
C128, 228	OB05639A	Tantalum Capacitor 1.5 μ 35V	TP-L, R	OB03924A	Test Pin
C129, 229	OB05813A	Mylar Capacitor 0.056 μ 50V J		OB08150A	5P Jack Ass'y 2 (1 pce.)
130, 230			JA03068A	Record Arm Ass'y (1 pce.)	
			OE00166A	Screw M2 x 4 Cylinder Head	
			OE00025A	Washer 2mm Spring	

8.2 Dolby P.C.B. Ass'y

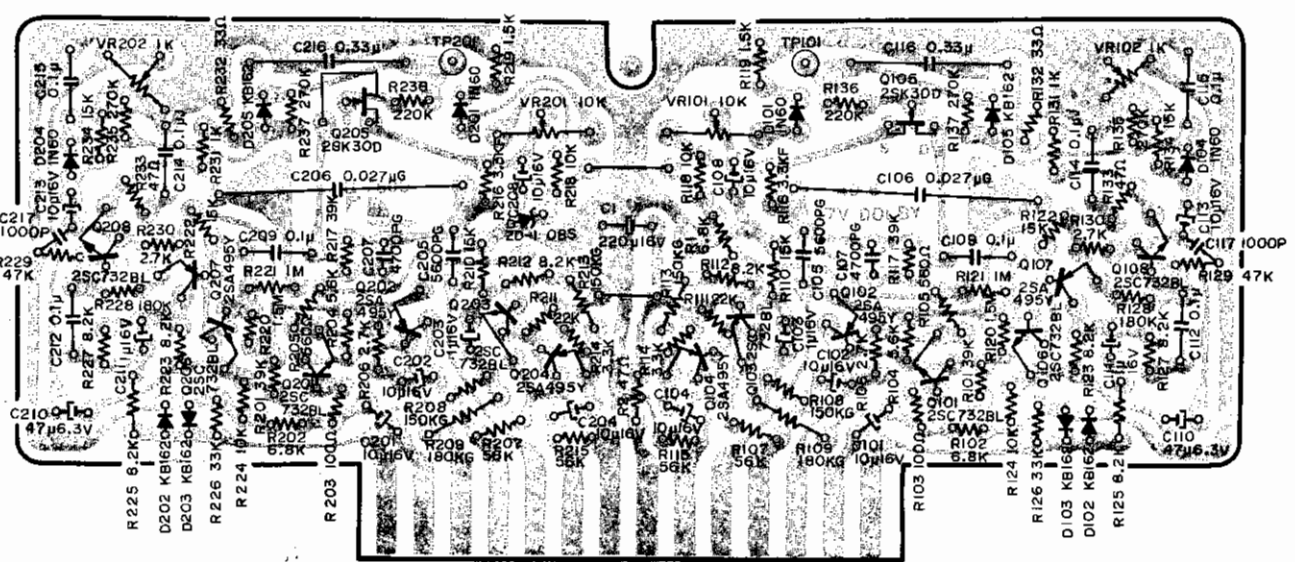

Fig. 8.2

Schematic Ref. No.	Part No.	Description	Schematic Ref. No.	Part No.	Description
	BA03670A	Dolby P.C.B. Ass'y	123, 223		
	OB07609A	17V Dolby P.C.B.	125, 225		
Q101, 201	OB06005A	Transistor	25C732 (BL)	R114, 214	OB01793A Carbon Resistor 3.3K ELR% J
103, 203				R116, 216	OB01585A Carbon Resistor 3.3K RD% F
106, 206				R118, 218	OB01833A Carbon Resistor 10K ELR% J
108, 208				124, 224	
Q102, 202	OB06006A	Transistor	2SA495 (Y)	R119, 219	OB05505A Carbon Resistor 1.5K ELR% J
104, 204				R120, 220	OB05601A Carbon Resistor 1.5M ELR% J
107, 207				R121, 221	OB05564A Carbon Resistor 1M ELR% J
Q105, 205	OB06001A	FET	2SK30A (D)	R126, 226	OB01879A Carbon Resistor 33K ELR% J
ZD1	OB06004A	Zener Diode	08S	R128, 228	OB05669A Carbon Resistor 180K ELR% J
D101, 201	OB00030A	Germanium Diode	1N60 (P)	R129, 229	OB05562A Carbon Resistor 47K ELR% J
104, 204				R131, 231	OB01781A Carbon Resistor 1K ELR% J
D102, 202	OB01599A	Silicon Diode	KB162	R132, 232	OB05567A Carbon Resistor 33 ELR% J
103, 203				R135, 235	OB05600A Carbon Resistor 270K ELR% J
105, 205				137, 237	
VR101, 201	OB01458A	Semi-fixed Volume	10K	R136, 236	OB05596A Carbon Resistor 220K ELR% J
VR102, 202	OB01428A	Semi-fixed Volume	1K	C1	OB01398A Electrolytic Capacitor 220μ 16V
R1, 102, 202	OB01877A	Carbon Resistor	6.8K ELR% J	C101, 201	OB01412A Electrolytic Capacitor 10μ 16V
R2, 133, 233	OB05569A	Carbon Resistor	47 ELR% J	102, 202	
R101, 201	OB01885A	Carbon Resistor	39K ELR% J	104, 204	
117, 217				108, 208	
R103, 203	OB05558A	Carbon Resistor	100 ELR% J	113, 213	
R104, 204	OB05673A	Carbon Resistor	5.6K ELR% J	C103, 203	OB01405A Electrolytic Capacitor 1μ 16V
R105, 205	OB05678A	Carbon Resistor	560 ELR% J	111, 211	
R106, 206	OB01782A	Carbon Resistor	2.7K ELR% J	C105, 205	OB01864A P.P. Capacitor 5600P 50V G
130, 230				C106, 206	OB01892A P.P. Capacitor 0.027μ 50V G
R107, 207	OB05563A	Carbon Resistor	56K ELR% J	C107, 207	OB01608A P.P. Capacitor 4700P 50V G
115, 215				C109, 209	OB01603A Mylar Capacitor 0.1μ 50V K
R108, 208	OB01859A	Carbon Resistor	150K RD% G	112, 212	
113, 213				115, 215	
R109, 209	OB01590A	Carbon Resistor	180K RD% G	C110, 210	OB01404A Electrolytic Capacitor 47μ 6.3V
R110, 210	OB05591A	Carbon Resistor	15K ELR% J	C114, 214	OB01780A Mylar Capacitor 0.1μ 50V J
122, 222				C116, 216	OB01602A Mylar Capacitor 0.33μ 50V K
134, 234				C117, 217	OB04059A Mylar Capacitor 1000P 50V K
R111, 211	OB05661A	Carbon Resistor	22K ELR% J	TP101, 201	OB03924A Test Pin
R112, 212	OB01878A	Carbon Resistor	8.2K ELR% J		

8.3. SW. P.C.B. Ass'y

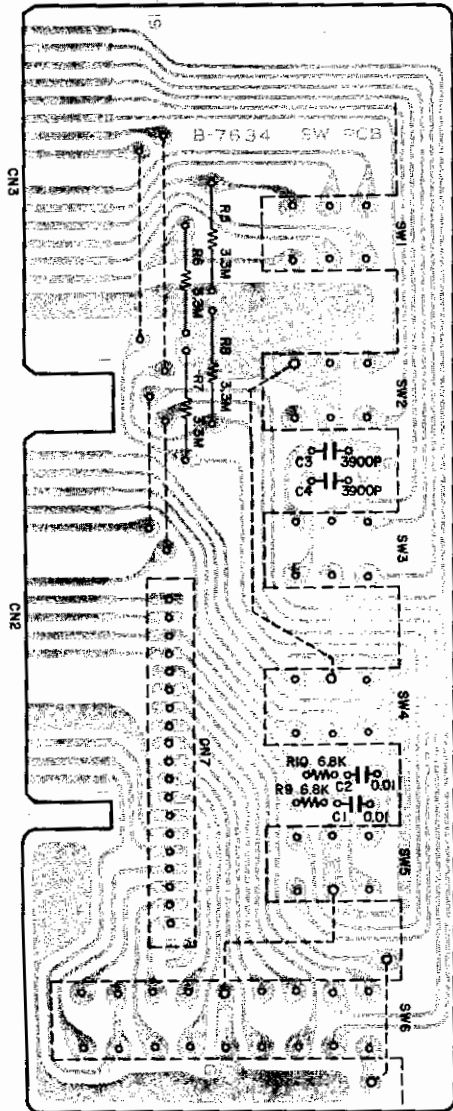

Fig. 8.3

8.4. CAL. P.C.B. Ass'y

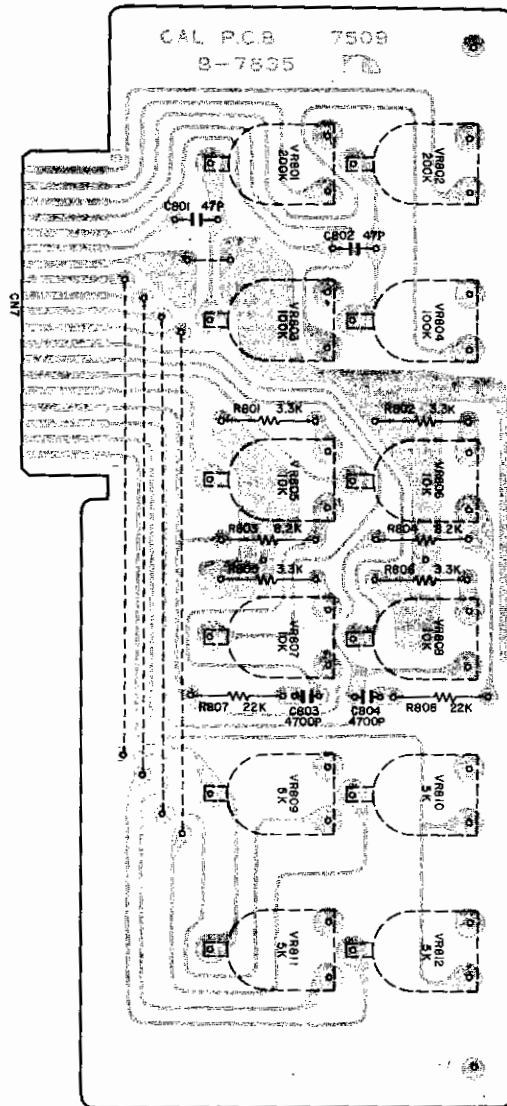

Fig. 8.4

Schematic Ref. No.	Part No.	Description	Schematic Ref. No.	Part No.	Description
	BA03719A	SW. P.C.B. Ass'y		BA03718A	CAL. P.C.B. Ass'y
SW1, 2, 3, 4, 5	OB07634A OB07088A	SW. P.C.B. Push SW.	VR801, 802	OB01597A	CAL. P.C.B. Semi-fixed Volume 200K
R5, 6, 7, 8	OB05803A	Carbon Resistor 3.3M R¼ J	VR803, 804	OB01812A	Semi-fixed Volume 100K
R9, 10	OB01877A	Carbon Resistor 6.8K ELR¼ J	VR805, 806	OB01595A	Semi-fixed Volume 10K
C1, 2	OB05681A	Mylar Capacitor 0.01µ 50V J	VR809, 810	OB01805A	Semi-fixed Volume 5K
C3, 4	OB01804A	Mylar Capacitor 3900p 50V J	VR809, 810	OB01805A	Semi-fixed Volume 5K
	BA03562A	19P Connector Sub Ass'y (1 pce.)	R801, 802 805, 806	OB01681A	Carbon Resistor 3.3K R¼ J
			R803, 804	OB01856A	Carbon Resistor 8.2K R¼ J
			R807, 808	OB05615A	Carbon Resistor 22K R¼ J
			C801, 802	OB01456A	Ceramic Capacitor 47P 50V
			C803, 804	OB05652A	Mylar Capacitor 4700P 50V J

8.5. VR P.C.B. Ass'y

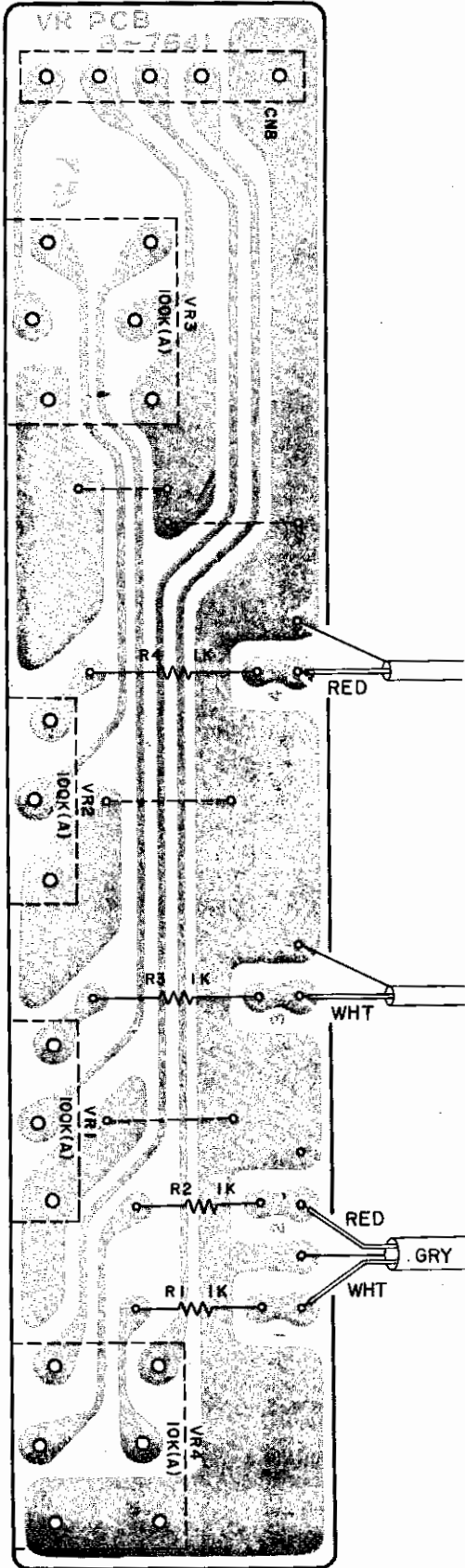

Fig. 8.5

8.6. DIN Pin Jack P.C.B. Ass'y

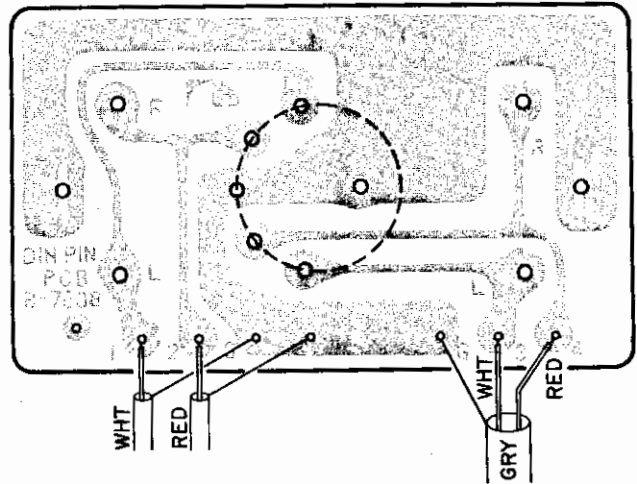

Fig. 8.6

8.7. Meter P.C.B. Ass'y

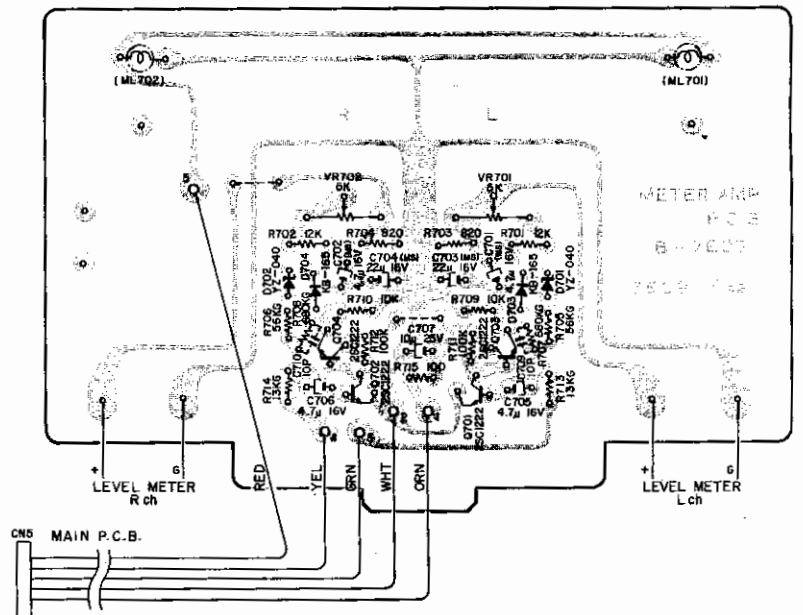

Fig. 8.7

8. 8. Power Supply P.C.B. Ass'y

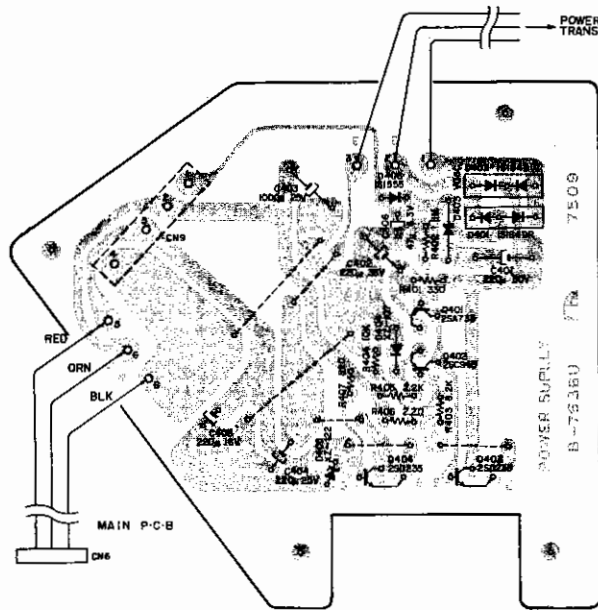

Fig. 8. 8

Schematic Ref. No.	Part No.	Description	Schematic Ref. No.	Part No.	Description
	BA03720A	VR P.C.B. Ass'y		BA03721A	Power Supply P.C.B. Ass'y
VR1, 2	OB07641A	VR P.C.B. Ass'y		OB07636U	Power Supply P.C.B.
VR3	OB07089A	Volume 100K (A)	Q401	OB06013A	Transistor 2SA733 (L)
VR4	OB07091A	Volume 100K (A)	Q402	OB01872A	Transistor 2SC945 (L)
R1, 2, 3, 4	OB07090A	Volume 10K (A)	Q403, 404	OB01823A	Transistor 2SD235 (Y)
	OB01857A	Carbon Resistor 1K R $\frac{1}{4}$ J	D401	OB06038U	Silicon Diode 1S1849R
	OB08140A	5P Plug (1 pce.)	D402	OB06037U	Silicon Diode 1S1849
	BA03726A	DIN Pin Jack P.C.B. Ass'y	D403	OB01501U	Silicon Diode VO-6C
	OB07638A	Jack P.C.B.	D404	OB06059A	Zener Diode XZ-107
	OB08097A	Jack Unit	D405	OB06065A	Zener Diode XZ-122
	BA03716A	Meter P.C.B. Ass'y	D406	OB01909A	Silicon Diode 1S1555
Q701, 702	OB07637A	Meter Amp. P.C.B.	R401	OB01789A	Carbon Resistor 330 ELR $\frac{1}{2}$ J
703, 704	OB06062A	Transistor 2SC1222 (2)	R402	OB05670A	Carbon Resistor 1.8M ELR $\frac{1}{2}$ J
D701, 702	OB06063A	Zener Diode YZ-040	R403	OB05823A	Carbon Resistor 6.2K ELR $\frac{1}{2}$ J
D703, 704	OB06007A	Silicon Diode KB165	R404	OB01833A	Carbon Resistor 10K ELR $\frac{1}{2}$ J
VR701, 702	OB01470A	Semi-fixed Volume 5K	R405	OB05566A	Carbon Resistor 2.2K ELR $\frac{1}{2}$ J
R701, 702	OB05650A	Carbon Resistor 12K ELR $\frac{1}{2}$ J	R406	OB05605A	Carbon Resistor 2.2 ELR $\frac{1}{2}$ J
R703, 704	OB05511A	Carbon Resistor 820 ELR $\frac{1}{2}$ J	R407	OB05511A	Carbon Resistor 820 ELR $\frac{1}{2}$ J
R705, 706	OB05821A	Carbon Resistor 56K RD $\frac{1}{2}$ G	C401	OB05839A	Electrolytic Capacitor 220 μ 50V
R707, 708	OB05822A	Carbon Resistor 680K RD $\frac{1}{2}$ G	C402	OB05831A	Electrolytic Capacitor 220 μ 35V
R709, 710	OB01833A	Carbon Resistor 10K ELR $\frac{1}{2}$ J	C403	OB01870A	Electrolytic Capacitor 1000 μ 25V
R711, 712	OB01920A	Carbon Resistor 100K ELR $\frac{1}{2}$ J	C404	OB01391A	Electrolytic Capacitor 220 μ 25V
R713, 714	OB05767A	Carbon Resistor 13K RD $\frac{1}{2}$ G	C405	OB01398A	Electrolytic Capacitor 220 μ 16V
R715	OB05558A	Carbon Resistor 100 ELR $\frac{1}{2}$ J	C406	OB01404A	Electrolytic Capacitor 47 μ 6.3V
C701, 702	OB05819A	Electrolytic Capacitor 4.7 μ 16V M (MS)	OJ03399A	Heat Sink (1 pce.)	
C703, 704	OB05820A	Electrolytic Capacitor 22 μ 16V M (MS)	OB08127A	4P Plug (1 pce.)	
C705, 706	OB01389A	Electrolytic Capacitor 4.7 μ 16V	OB08153A	3P Jack Ass'y 1 (1 pce.)	
C707	OB01674A	Electrolytic Capacitor 10 μ 25V	OE00607A	Screw M3 x 8 Philips Pan Head (3A) (2 pcs.)	
C709, 710	OB05798A	Ceramic Capacitor 10P 50V	OE00608A	Screw M3 x 10 Philips Pan Head (3A) (2 pcs.)	
	OB08151A	5P Jack Ass'y (1 pce.)	OE00507A	Nut Hex M3 (4 pcs.)	

8. 9. Shut-off P.C.B. Ass'y

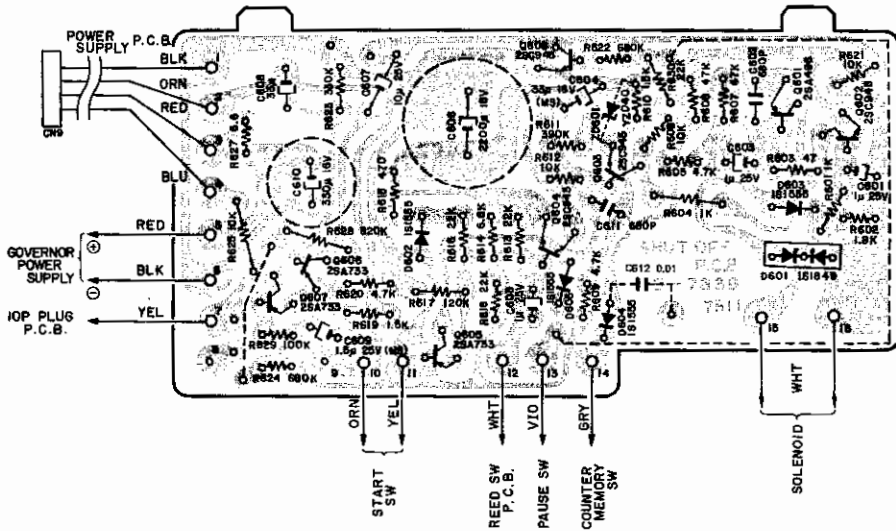
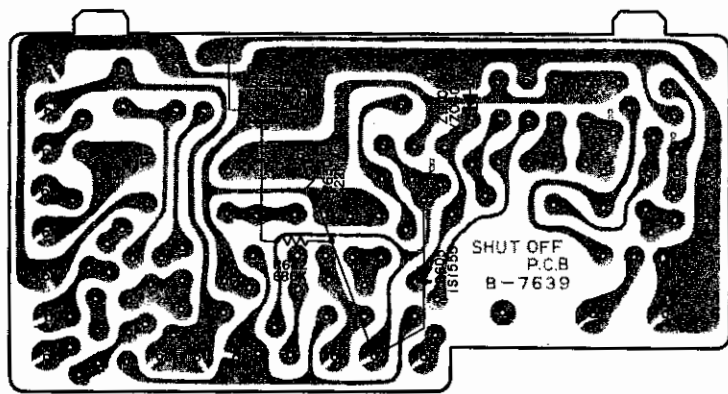
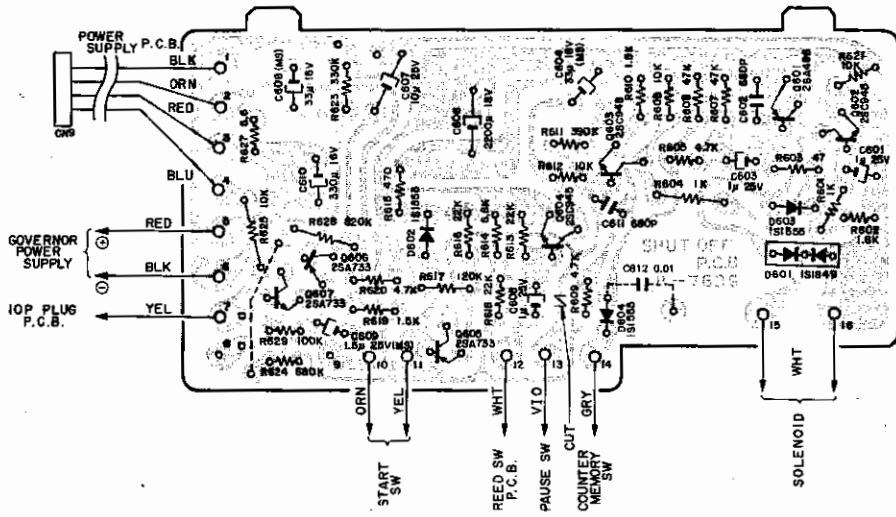

Fig. 8. 9. 1 (Serial No. 3811501-)



Note:
Parts are soldered
to the dip side of
P.C.B.

Fig. 8. 9. 2 (Serial No. 3811500)

8. 10. MHX Governor P.C.B. Ass'y

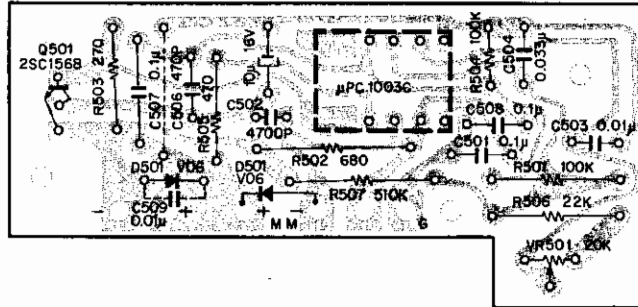

Fig. 8.10

Schematic Ref. No.	Part No.	Description	Schematic Ref. No.	Part No.	Description
	BA03722A	Shut-off P.C.B. Ass'y	R614	0B01877A	Carbon Resistor 6.8K ELR% J
	0B07639B	Shut-off P.C.B.	R615	0B01792A	Carbon Resistor 470 ELR% J
Q601	0B01695A	Transistor 2SA496 (O)	R617	0B05568A	Carbon Resistor 120K ELR% J
Q602, 603	0B01872A	Transistor 2SC945 (L)	R622, 624	0B05597A	Carbon Resistor 680K ELR% J
604, 608			R623	0B01921A	Carbon Resistor 330K ELR% J
Q605, 606	0B06013A	Transistor 2SA733 (L)	R627	0B05818A	Carbon Resistor 5.6 ELR% J
607			R628	0B05674A	Carbon Resistor 820K ELR% J
ZD601	0B06063A	Zener Diode YZ040	R629	0B01920A	Carbon Resistor 100K ELR% J
D601	0B06037U	Silicon Diode 1S1849	C602, 611	0T04027A	Ceramic Capacitor 680P 50V
D602, 603	0B01909A	Silicon Diode 1S1555	C601, 603	0B01173A	Electrolytic Capacitor 1μ 25V
604, 605			605		
R601, 604	0B01781A	Carbon Resistor 1K ELR% J	C604, 608	0B05817A	Electrolytic Capacitor 33μ 16V M (MS)
R602	0B01830A	Carbon Resistor 1.8K ELR% J	C606	0B01835A	Electrolytic Capacitor 2200μ 18V
R603	0B05569A	Carbon Resistor 47 ELR% J	C607	0B01674A	Electrolytic Capacitor 10μ 25V
R605, 609	0B01795A	Carbon Resistor 4.7K ELR% J	C609	0B05815A	Electrolytic Capacitor 1.5μ 25V M (MS)
620			C610	0B01502A	Electrolytic Capacitor 330μ 16V
R606, 607	0B05562A	Carbon Resistor 47K ELR% J	C612	0B01609A	Mylar Capacitor 0.01μ 50V K
R608, 612	0B01833A	Carbon Resistor 10K ELR% J	0B08001A	Tub (2 pcs.)	
621, 625			0B08152A	4P Jack Ass'y 2 (1 pce.)	
R610, 619	0B05505A	Carbon Resistor 1.5K ELR% J	0E00037A	Earth Lug B-5 (1 pce.)	
R611	0B05595A	Carbon Resistor 390K ELR% J			
R613, 616	0B05661A	Carbon Resistor 22K ELR% J			
618, 630					
				CA03250A	MHX Governor P.C.B. Ass'y

9. MECHANISM ASS'Y & PARTS LIST

9.1. Synthesis Ass'y (A01)

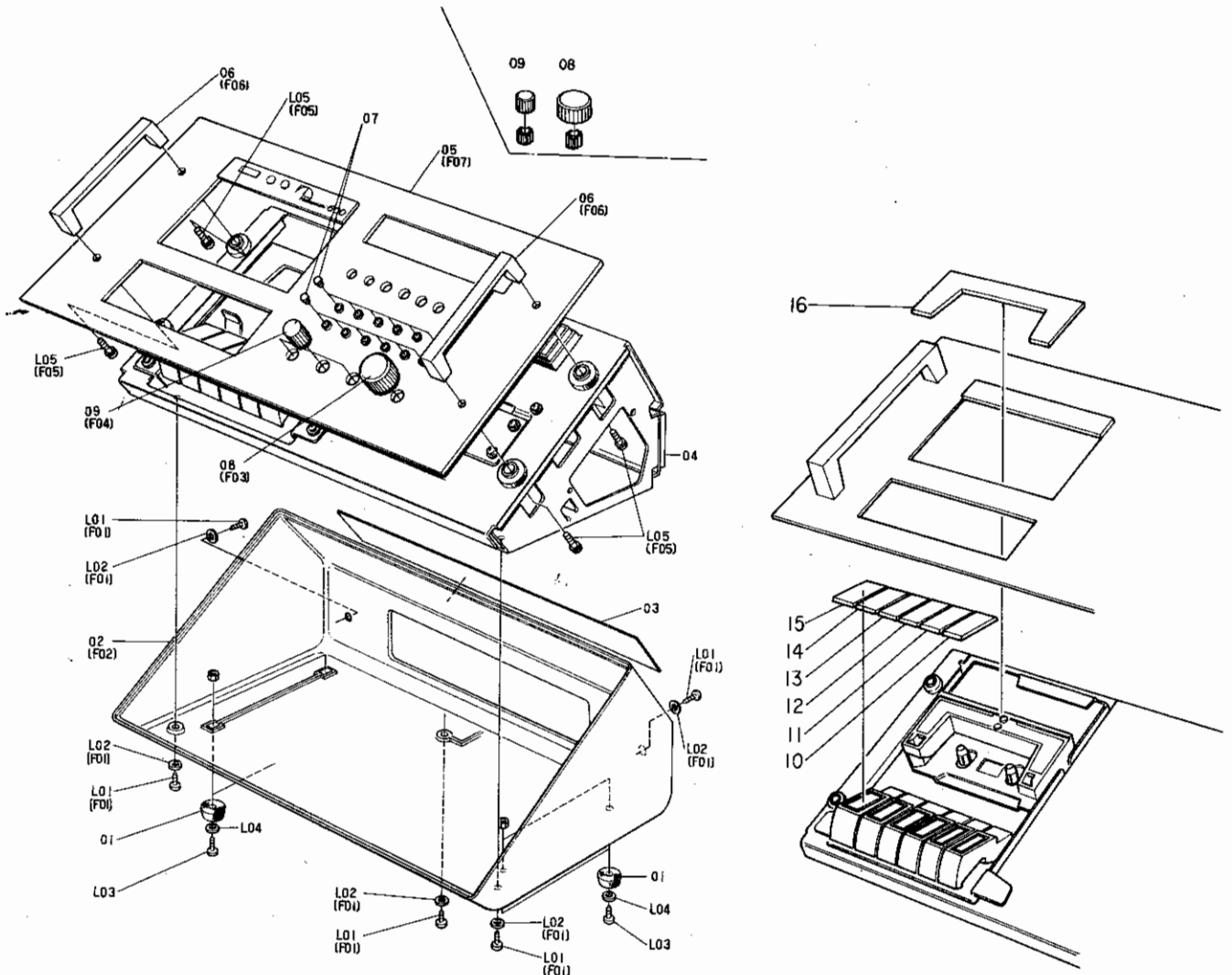

Fig. 9.1

Schematic Ref. No.	Part No.	Description	Q'ty	Schematic Ref. No.	Part No.	Description	Q'ty
A01		Synthesis Ass'y					
01	0A00518C	Foot	4	12	0H03407B	Button Cover PLAY	1
02	0A03253A	Cabinet	1	13	0H03406B	Button Cover STOP	1
	0M03619A	Gate Screen Plate	1	14	0H03405B	Button Cover REW.	1
	0M03339A	Caution Label	1	15	0H03404B	Button Cover REC.	1
03	0M03618A	Cabinet Plate	1	16	0H03402A	Lid Cover	1
04	JA03065A	Chassis Ass'y	1	L01	0E00594A	Screw M3 x 8 Philips Bind Head (Bronze)	5
05	HA03628A	Front Panel Ass'y	1	L02	0E00197A	Washer 3mm (Bronze)	5
06	HA03632A	Handle Ass'y	2	L03	0E00701A	Screw M3 x10 Philips Bind Head (Bronze)	4
07	0H03399A	S.F.R. Cover	12	L04	0E00253A	Washer 3mm	4
08	HA03631A	V.R. Cap (B) Ass'y	1	L05	0E00700A	Screw M5 x 16 Philips Pan Head (2A)	4
09	HA03630A	V.R. Cap (A) Ass'y	3				
10	0H03409B	Button Cover PAUSE	1				
11	0H03408B	Button Cover F.F.	1				

9. 2. Chassis Ass'y

9. 2. 1. Chassis Ass'y (A02-1)

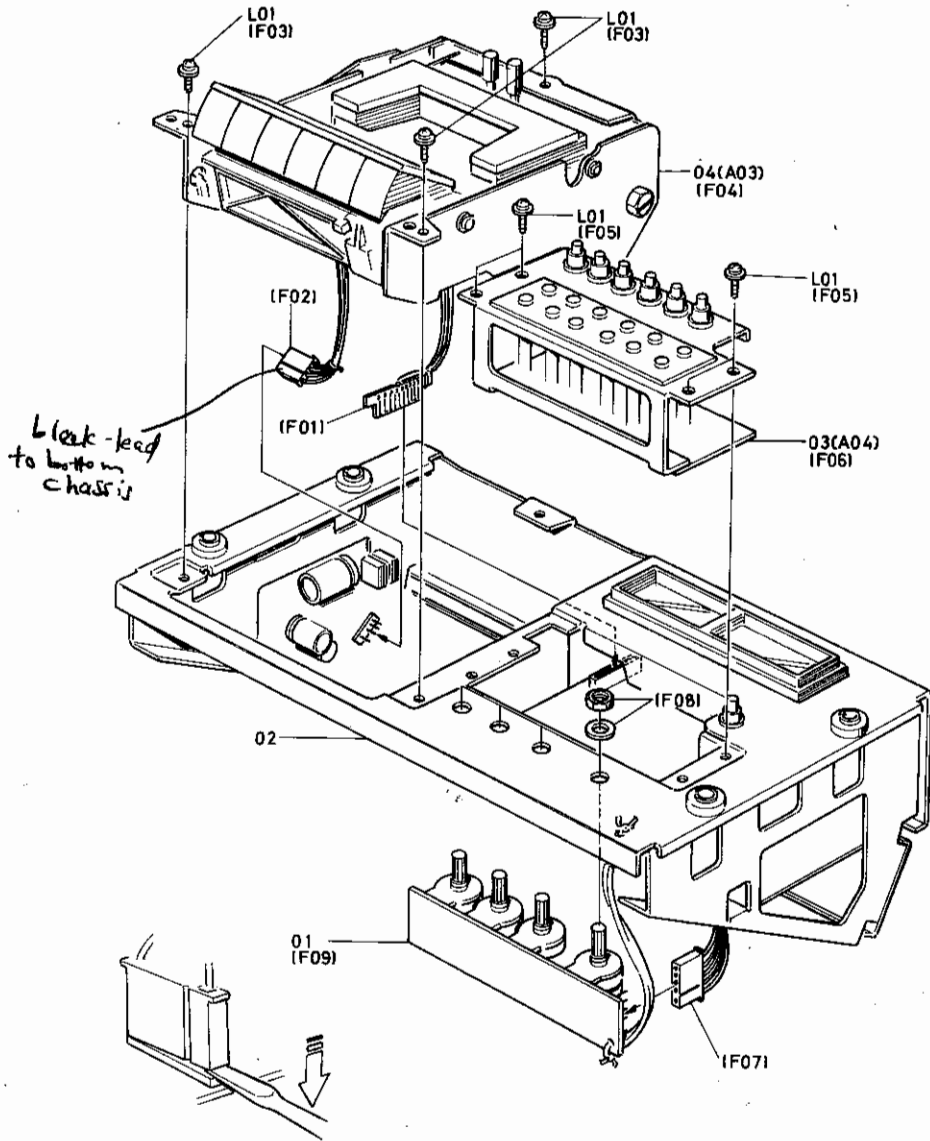

Fig. 9. 2. 1

Schematic Ref. No.	Part No.	Description	Q'ty
A02-1	JA03065A	Chassis Ass'y	1
01	BA03720A	V.R. P.C.B. Ass'y	1
02	JA03055A	Main Chassis Ass'y	1
03	JA03053A	Front Control Ass'y	1
04	CA03256A	Mechanism Ass'y	1
L01	0E00606A	Screw M3 x 6 Philips Pan Head (3A)	5

9. 2. 2. Chassis Ass'y (A02-2)

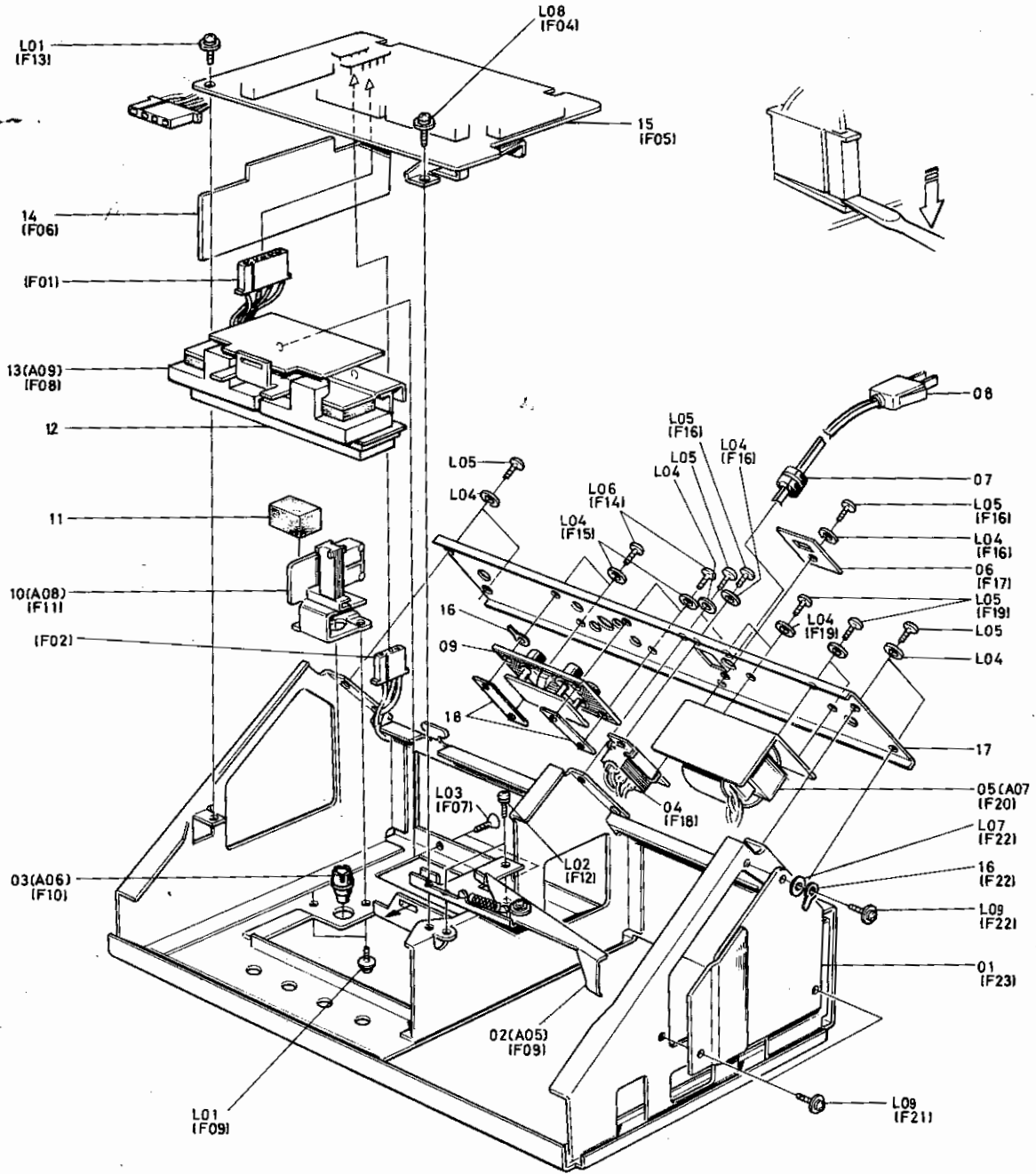

Fig. 9. 2. 2

Schematic Ref. No.	Part No.	Description	Q'ty
A02-2	JA03065A	Chassis Ass'y	1
01	BA03721A	Power Supply P.C.B. Ass'y	1
02	JA03064A	Record Link Ass'y	1
03	JA03061A	Push Button Ass'y	1
04	0B07092U	Voltage Selector	1
05	JA03058A	Power Transformer Ass'y	1
06	0M03627A	Voltage Lock Plate	1
07	0B08037U	Cord Bushing C	1
08	0B03900U	Power Cord	1
09	BA03726A	DIN Pin Jack Ass'y	1
10	JA03063A	Power SW. Ass'y	1
11	0J03421A	Dolby N.R. P.C.B. Pad	1
12	0J03417A	Meter Escutcheon	1
13	JA03067A	Meter Ass'y	1
14	BA03670A	Dolby N.R. P.C.B. Ass'y	1
15	BA03715A	Main P.C.B. Ass'y	1
16	0E00037A	Earth Lug B-5	2
17	JA03059A	Rear Panel Sub Ass'y	1
18	0J03277A	Metal Seat Nut	2
L01	0E00606A	Screw M3 x 6 Philips Pan Head (3A)	3
L02	0E00612A	Screw M3 x 6 Philips Pan Head (2A)	2
L03	0E00505A	Screw M3 x 6 Philips Counter-sunk	2
L04	0E00157A	Washer 3mm collar	16
L05	0E00589A	Screw M3 x 6 Philips Pan Head (Bronze)	12
L06	0E00588A	Screw M3 x 8 Philips Pan Head (Bronze)	4
L07	0E00071A	Washer 3mm Fiber	1
L08	0E00660A	Screw M3 x 12 Philips Pan Head (3A)	1
L09	0E00607A	Screw M3 x 8 Philips Pan Head (3A)	3

9.3. N600 Mechanism Ass'y (A03)

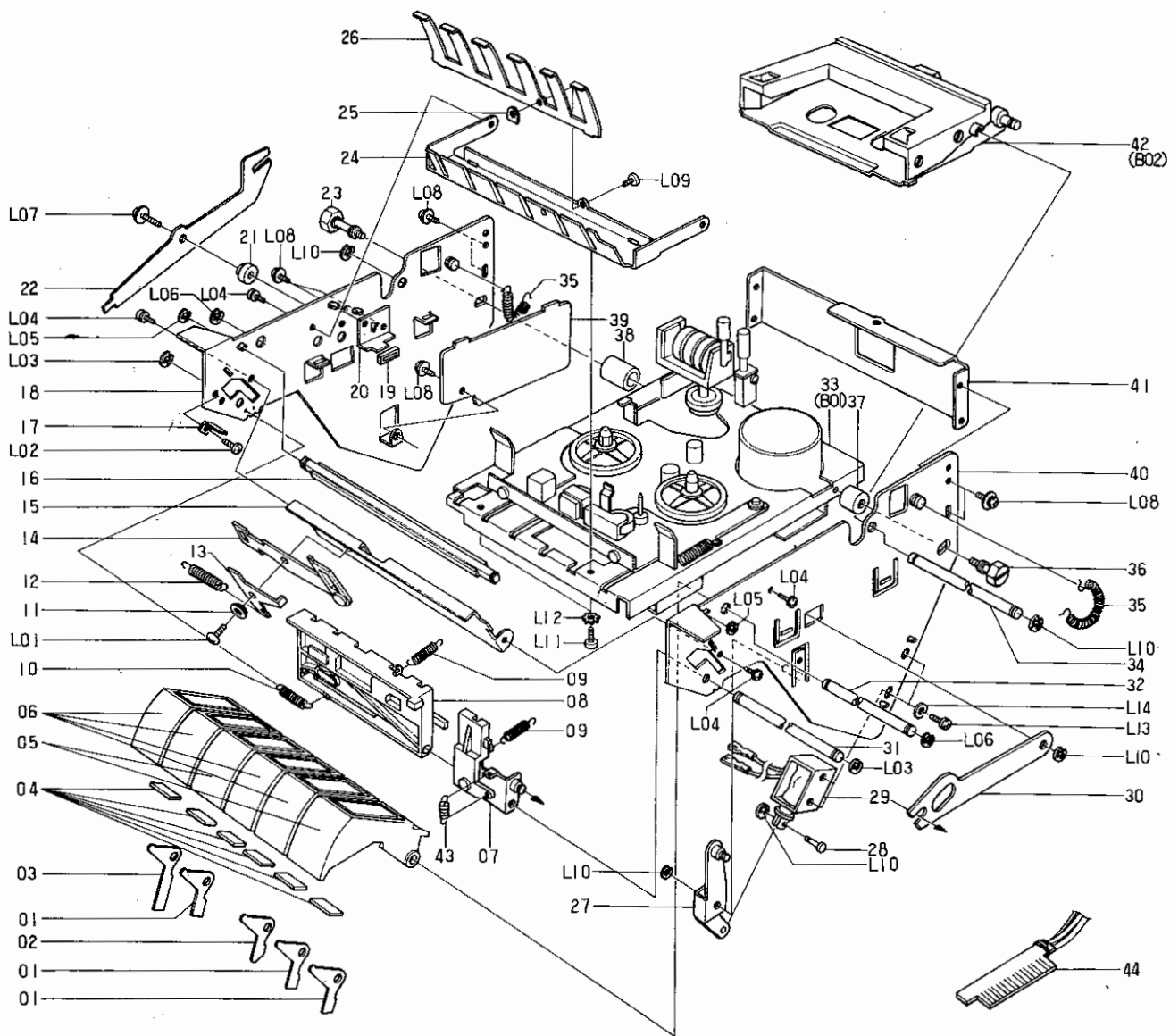

Fig. 9.3

Schematic Ref. No.	Part No.	Description	Q'ty
A03	CA03255A	N600 Mechanism Ass'y	1
01	0C03892A	Button Cam (B)	3
02	0C03893A	Button Cam (C)	1
03	0C03891A	Button Cam (A)	1
04	0C03894A	Button Plate	6
05	CA03260A	Deck Button S Ass'y	2
06	CA03261A	Deck Button R Ass'y	4
07	CA03263A	Pause Lock Plate Ass'y	1
08	0C03896A	Lock Plate	1
09	0C03899A	Pause Lock Spring (B)	2
10	0C03897A	Lock Plate Slide Spring	1
11	0C03883A	Eject Linkage Collar	1
12	0C03900A	Eject Arm Spring	1
13	0C03882A	Lock Plate Slide Lever	1
14	CA03257A	Eject Bar Ass'y	1
15	0C03881A	Front Hold Plate	1
16	CA03262A	Button Stopper Ass'y	1
17	0C03945A	Lock Plate Stopper	1
18	CA03258A	Side Plate L Ass'y	1
19	0C03885A	Lid Damper Rubber	1
20	0C03884A	Lid Adjust Plate	1
21	0C03905A	Lever Collar	1
22	0C03904A	Eject Joint Bar	1
23	0C03887A	Side Plate L Bolt	1
24	0C03878A	Button Guide	1
25	0C03880A	Button Spring Holder	1
26	0C03879A	Button Spring	1
27	CA03265A	Shut-off Arm Ass'y	1
28	0C03906A	Solenoid Pin	1
29	BA03727A	Solenoid sub Ass'y	1
30	0C03907A	Shut-off Bar	1
31	0C03901A	Lock Shaft	1
32	0C03895A	Button Shaft	1
33	CA03256A	N600 Mechanism Sub Ass'y	1
34	0C03903A	Lid Shaft	1
35	0C03902A	Lid Spring	2
36	0C03889A	Side Plate R Bolt	1
37	0C03888A	Side Plate R Collar	1
38	0C03886A	Side Plate L Collar	1
39	BA03722A	Shut-off P.C.B. Ass'y	1
40	CA03259A	Side Plate R Ass'y	1
41	0C03890A	Rear Hold Plate	1
42	CA03264A	Cassette Case Ass'y	1
43	0C03898A	Pause Lock Spring	1
44	0B07551A	10P Plug Board	1
L01	0E00121A	Screw M2.6 x 6 Philips Pan Head	1
L02	0E00226A	Screw M2.6 x 4 Philips Pan Head	1
L03	0E00181A	E Ring 3mm	2
L04	0E00612A	Screw M3 x 6 Philips Pan Head (2A)	4
L05	0E00698A	E Ring 2.5mm	2
L06	0E00134A	E Ring 4mm	2
L07	0E00610A	Screw M3 x 12 Philips Pan Head (3A)	1
L08	0E00606A	Screw M3 x 6 Philips Pan Head (3A)	7
L09	0E00166A	Screw M2 x 4 Cylinder Head	1
L10	0E00222A	E Ring 2mm	5
L11	0E00509A	Screw M3 x 6 Philips Pan Head	2
L12	0E00172A	Washer 3mm Toothed Lock	2
L13	0E00622A	Screw M3 x 5 Philips Pan Head (2A)	2
L14	0E00597A	Washer 3mm	2

9.4. Front Control Ass'y (A04)

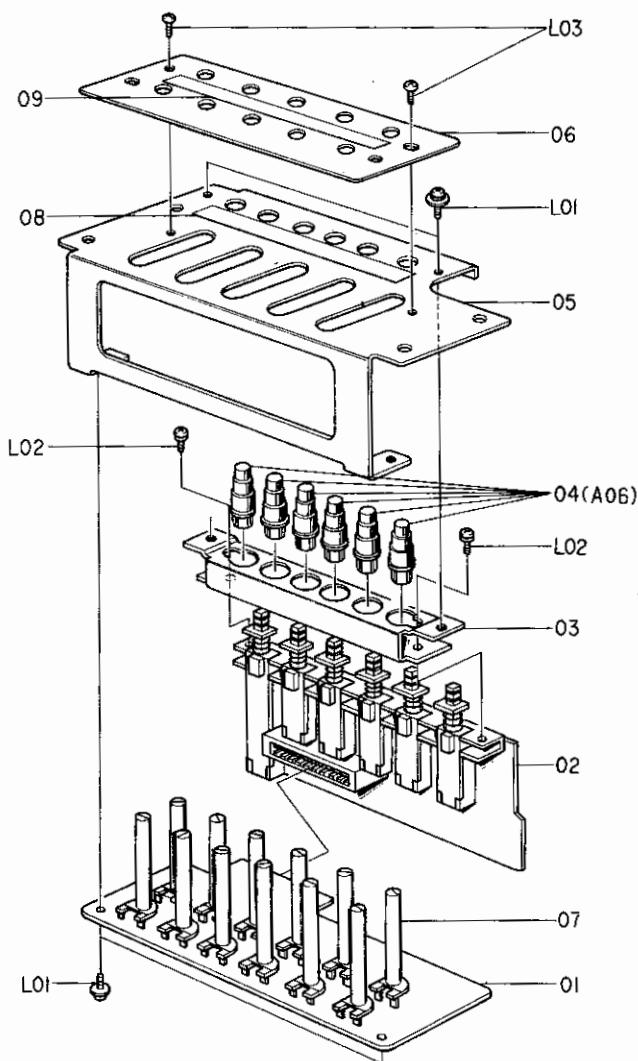

Fig. 9.4

Schematic Ref. No.	Part No.	Description	Q'ty
A04	JA03053A	Front Control Ass'y	1
01	BA03718A	CAL. P.C.B. Ass'y	1
02	BA03719A	SW. P.C.B. Ass'y	1
03	0J03410A	SW. Holder	1
04	JA03061A	Push Button Ass'y	6
05	0J03409A	Switch Cover	1
06	0J03411A	CAL. Cover	1
07	0B08157A	CAL. Knob	12
08	0M03629A	CAL. Label	1
09	0M03628A	SW. Label	1
L01	0E00606A	Screw M3 x 6 Philips Pan Head (3A)	4
L02	0E00612A	Screw M3 x 6 Philips Pan Head (2A)	2
L03	0E00226A	Screw M2.6 x 4 Philips Pan Head	2

9.5. Record Link Ass'y (A05)

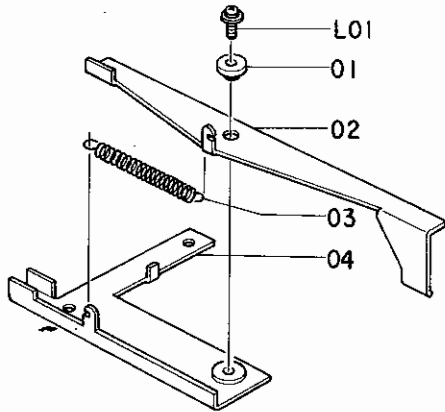

Fig. 9.5

9.8. Power SW. Ass'y (A08)

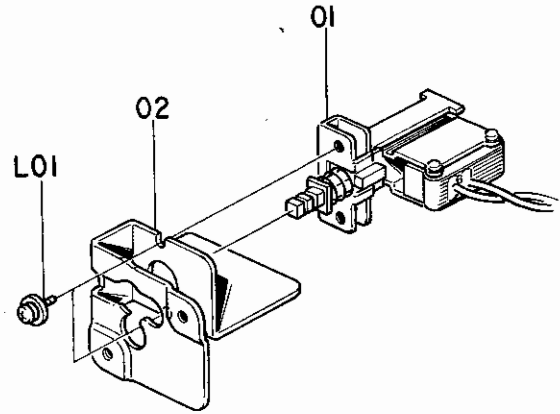

Fig. 9.8

9.6. Push Button Ass'y (A06)

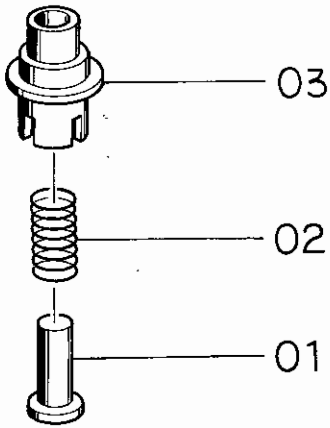

Fig. 9.6

9.7. Power Trans. Ass'y (A07)

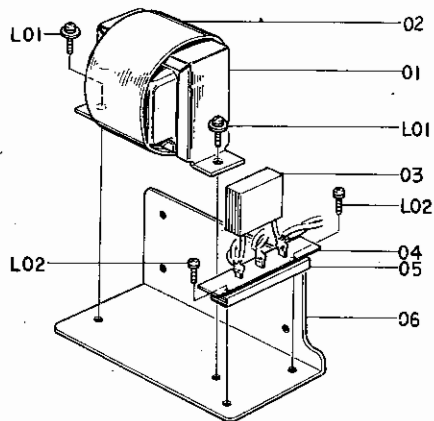

Fig. 9.7

9.9. Meter Ass'y (A09)

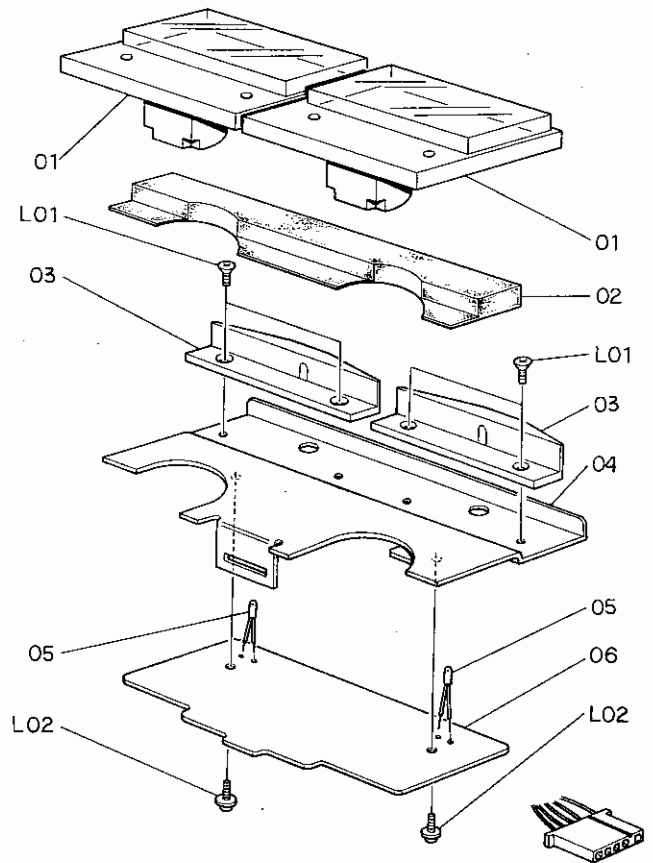

Fig. 9.9

Schematic Ref. No.	Part No.	Description	Q'ty
A05	JA03064A	Record Link Ass'y	1
01	0J03396A	Record Link Collar	1
02	0J03420A	Record Link	1
03	0J03423A	Record Link Spring	1
04	0J03419A	Record Arm Chassis	1
L01	0E00607A	Screw M3 x 8 Philips Pan Head (3A)	1
A06	JA03061A	Push Button Ass'y	7
01	0J03413A	Push Button	1
02	0J03414A	SW. Spring	1
03	0J03412A	Push Button Flange	1
A07	JA03058A	Power Trans. Ass'y	1
01	0B06537U	Power Trans.	1
02	0J03051A	Trans. Shield Plate	1
03	0B03873U	Spark Killer	1
04	0B08030U	3P Terminal Insulator (A)	1
05	0B08024U	3P Terminal Strip	1
06	0J03422A	Trans. Holder	1
L01	0E00606A	Screw M3 x 6 Philips Pan Head (3A)	2
L02	0E00510A	Screw M3 x 8 Philips Pan Head (2A)	2
A08	JA03063A	Power SW. Ass'y	1
01	0B07093U	Power SW.	1
02	0J03408A	Power SW. Holder	1
L01	0E00606A	Screw M3 x 6 Philips Pan Head (3A)	2
A09	JA03067A	Meter Ass'y	1
01	0B08154A	Level Meter	2
02	0J03424A	Meter Cushion	1
03	0J03418A	Lamp House	2
04	JA03052A	Meter Holder Sub Ass'y	1
05	0B08155A	Meter Lamp	2
06	BA03716A	Meter P.C.B. Ass'y	1
L01	0E00602A	Screw M3 x 4 Philips Counter-sunk	2
L02	0E00606A	Screw M3 x 6 Philips Pan Head (3A)	2

9. 10. N600 Mechanism Sub Ass'y

9. 10.2. N600 Mechanism Sub Ass'y (B01-2)

9. 10.1. N600 Mechanism Sub Ass'y (B01-1)

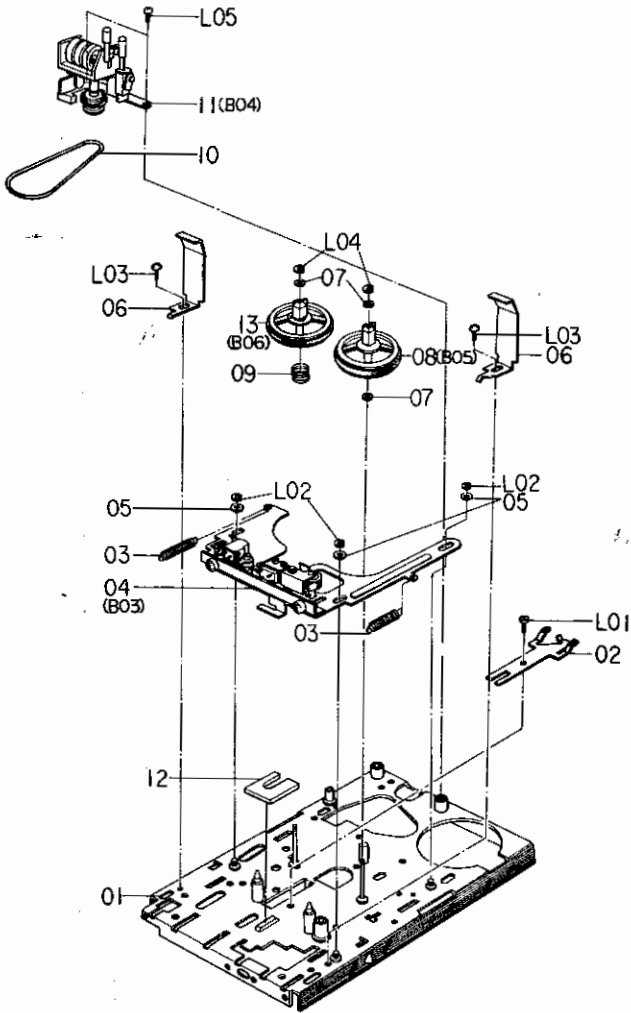

Fig. 9. 10. 1

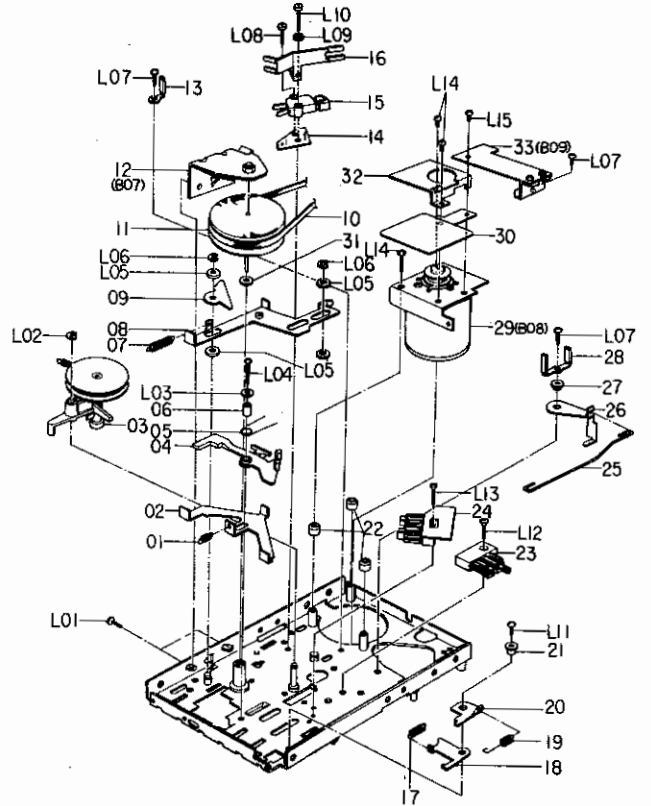

Fig. 9. 10. 2

Schematic Ref. No.	Part No.	Description	Q'ty	Schematic Ref. No.	Part No.	Description	Q'ty
B01-1	CA03256A	N600 Mechanism Sub Ass'y	1	L07	0E00228A	Screw M2.6 x 6 Philips Pan Head (FT)	3
01	CA03266A	Mechanism Chassis (B) Ass'y	1	L08	0E00004A	Screw M2 x 8 Cylinder Head	1
02	CA03140A	Brake Ass'y	1	L09	0E00025A	Washer 2mm Spring	1
03	0C03694B	Base Return Spring	2	L10	0E00218A	Screw M2 x 10 Cylinder Head	1
04	CA03269A	Head Base (B) Ass'y	1	L11	0E00231A	Screw M2.6 x 8 Philips Pan Head (FT)	1
05	0C06243A	W-4-8-0.2F	3	L12	0E00008A	Screw M2.6 x 8 Countersunk	1
06	0C03908A	Cassette Guide (D)	2	L13	0E00223A	Screw M2 x 10 Countersunk	1
07	0C03613A	Washer 1.6mm Plastics	3	L14	0E00220A	Screw M2.6 x 8 Philips Pan Head	3
08	CA03269A	Reel Hub T (B) Ass'y	1	L15	0E00219A	Screw M2.6 x 5 Philips Pan Head	1
09	CA03268A	Reel Hub S (B) Ass'y	1				
10	0C03651A	Counter Belt (E)	1				
11	CA03271A	Counter Holder Ass'y	1				
12	0C03863A	Head Base Spacer	1				
L01	0E00166A	Screw M2 x 4 Cylinder Head	1				
L02	0E00181A	E Ring 3mm	3				
L03	0E00226A	Screw M2.6 x 4 Philips Pan Head	2				
L04	0E00165A	E Ring 1.2mm	2				
L05	0E00219A	Screw M2.6 x 5 Philips Pan Head	2				
B01-2	CA03256A	N600 Mechanism Sub Ass'y	1				
01	0C03649A	See-Saw Arm Spring	1				
02	0C03647B	See-Saw Arm	1				
03	CA03150A	Idler Pulley Ass'y	1				
04	0C03646A	FRP Lever (B)	1				
05	0C03650B	Lever Spring	1				
06	0C03648A	See-Saw Arm Pipe	1				
07	0C03748A	Slide Plate Spring	1				
08	0C03744B	Pause Slide Plate	1				
09	0C03746C	Pause Bar	1				
10	0C03668A	Driving Belt	1				
11	CA03225A	Flywheel (B) Ass'y	1				
12	CA03226A	Flywheel Holder (C) Ass'y	1				
13	0C03691A	Cord Holder	1				
14	0C03800A	Pause Switch Mylar	1				
15	0C03743A	Pause Switch	1				
16	0C03799E	Belt Guide	1				
17	0C03774A	Base Cam Spring	1				
18	0C03773C	Base Cam	1				
19	0C03791A	Record Lock Spring (B)	1				
20	0C03652C	Record Lock (B)	1				
21	0C03775C	Base Cam Shaft	1				
22	0C03805B	Stud Collar (B)	3				
23	CA03141A	Mute Switch Ass'y	1				
24	CA03231A	Start Switch (C) Ass'y	1				
25	0C03704A	Record Sensor Linkage (B)	1				
26	0C03909A	Record Sensor (B)	1				
27	0C03646A	Record Lock Shaft	1				
28	0B03067A	Bind Holder	1				
29	CA03253A	MHX Motor Ass'y	1				
30	0C03859A	Shield Plate	1				
31	0C03174A	Washer 2.1mm Plastics	1				
32	0C03814D	Motor Shield	1				
33	CA03250A	MHX Governor P.C.B. Ass'y	1				
L01	0E00226A	Screw M2.6 x 4 Philips Pan Head	2				
L02	0E00222A	E Ring 2mm	1				
L03	0E00142A	Washer 2.6mm	1				
L04	0E00229A	Screw M2.6 x 10 Philips Pan Head	1				
L05	0E00031A	Washer 4mm	4				
L06	0E00181A	E Ring 3mm	2				

9. 11. Cassette Case Ass'y (B02)

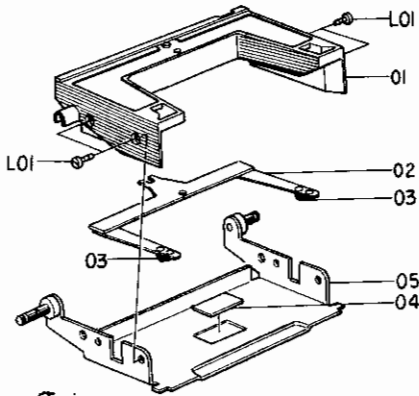

Fig. 9. 11

9. 13. Counter Holder Ass'y (B04)

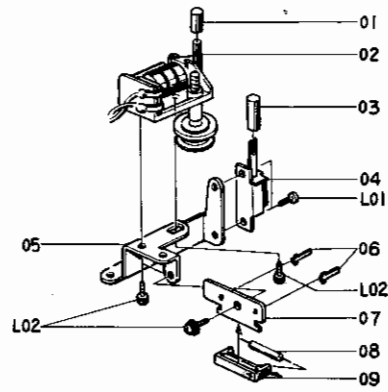

Fig. 9. 13

9. 12. Head Base (B) Ass'y (B03)

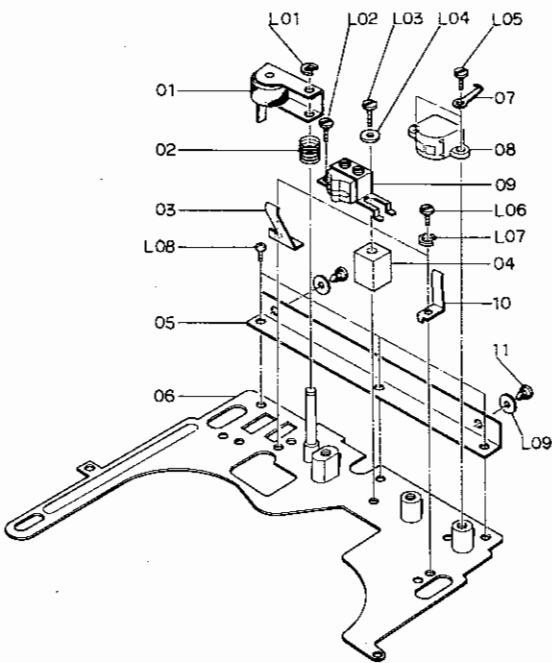

Fig. 9. 12

9. 14. Reel Hub T (B) Ass'y (B05)

9. 15. Reel Hub S (B) Ass'y (B06)

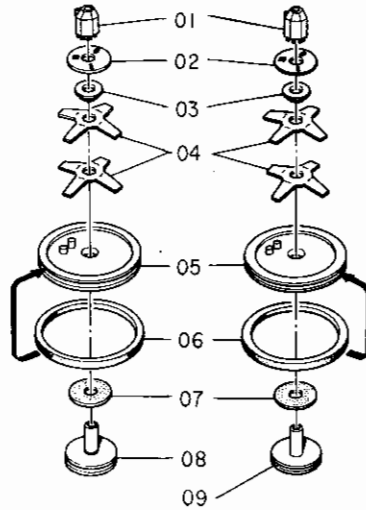

Fig. 9. 14

9. 16. Flywheel Holder (C) Ass'y (B07)

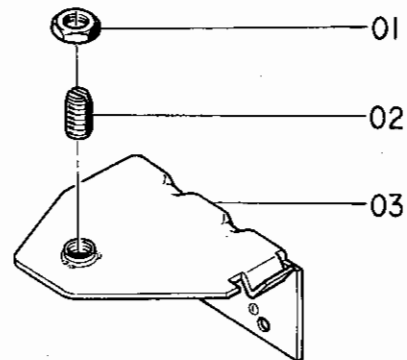

Fig. 9. 15

9. 17. MHX Motor Ass'y (B08)

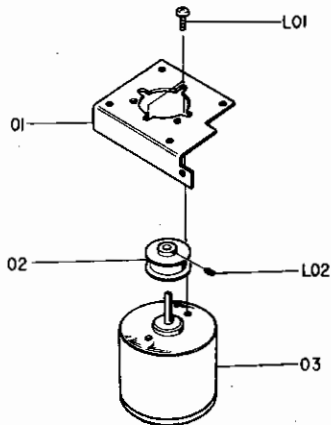

Fig. 9. 16

9. 18. Record/Playback Head Ass'y (B09)

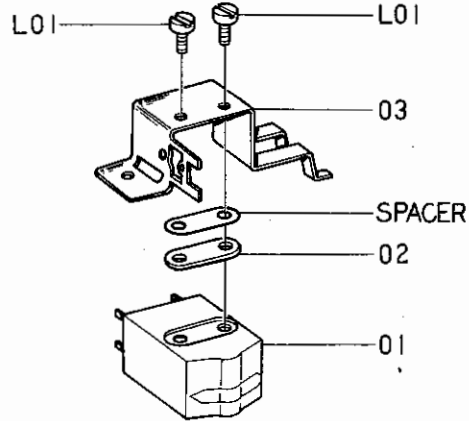

Fig. 9. 17

Schematic Ref. No.	Part No.	Description	Q'ty	Schematic Ref. No.	Part No.	Description	Q'ty
B02	CA03264A	Cassette Case Ass'y	1	B05	CA03269A	Reel Hub T (B) Ass'y	1
01	0C03925B	Cassette Lid	1	01	0C03785B	Sprocket (B)	1
02	CA03274A	SP. Base Plate Ass'y	1	02	0C03786B	Torque Plate	1
03	0C03924A	Cassette Stabilizer	2	03	0C03521A	Thrust Bearing	1
04	0M03638A	Silver Plate 600	1	04	0C03520D	Reel Hub Spring	2
05	CA03273B	Cassette Well Ass'y	1	05	0C03943A	Pulley (B)	1
L01	0E00699A	Screw M2 x 4 Cylinder Head	1	06	0C03522A	Reel Hub Ring	1
				07	0C03519E	Reel Hub Felt	1
				09	0C03689A	Pulley (F)	1
B03	CA03267A	Head Base (B) Ass'y	1	B06	CA03268A	Reel Hub S (B) Ass'y	1
01	CA03276A	Pressure Roller (B) Ass'y	1	01	0C03785B	Sprocket (B)	1
02	0C03758B	Pressure Roller Spring (B)	1	02	0C03786B	Torque Plate	1
03	0C03691A	Cassette Retainer Spring R	1	03	0C03521A	Thrust Bearing	1
04	0C03588A	Azimuth Adjust Rubber	1	04	0C03520D	Reel Hub Spring	2
05	0C03942A	Base Angle (B)	1	05	0C03943A	Pulley (B)	1
06	CA03275A	Head Base (B) Sub Ass'y	1	06	0C03522A	Reel Hub Ring	1
07	0C03591A	Cord Holder	2	07	0C03519E	Reel Hub Felt	1
08	0C03862A	Erase Head	1	08	0C03516A	Pulley (C)	1
09	CA03201B	Record/Playback Head Ass'y	1	B07	CA03226B	Flywheel Holder (C) Ass'y	1
10	0C03690A	Cassette Retainer Spring L	1	01	0C03857A	Lock Nut	1
11	0C03767A	Base Stopper Rubber	1	02	CA03281A	Thrust Screw Ass'y	1
L01	0E00042A	E Ring 1.5mm	1	03	CA03280A	Flywheel Holder (C) Sub Ass'y	1
L02	0E00166A	Screw M2 x 4 Cylinder Head	1	B08	CA03253A	MHX Motor Ass'y	1
L03	0E00218A	Screw M2 x 10 Cylinder Head	1	01	0J03221A	Motor Bracket C	1
L04	0E00149A	Washer 2.3mm	1	02	0C03712A	Motor Pulley TC-B	1
L05	0E00185A	Screw M2 x 6 Cylinder Head	2	03	0C03874A	MHX Motor	1
L06	0E00002A	Screw M2 x 3 Cylinder Head	2	L01	0E00120A	Screw M2 x 3 Philips Pan Head	2
L07	0E00025A	Washer 2mm Spring	2	L02	0E00224A	Screw M2 x 3 Cone Point	1
L08	0E00120A	Screw M2.6 x 3 Philips Pan Head	3	B09	CA03207B	Record/Playback Head Ass'y	1
L09	0E00030A	Washer 3mm Steel	2	01	GA02009L	RP-52 Record/Playback Head	1
B04	CA03271A	Counter Holder Ass'y	1	02	0G01100B	Head Hold Spacer	1
01	0C03933A	Counter Knob	1	03	0G01099C	Head Holder (B)	1
02	CA03279A	Tape Counter Ass'y	1	L01	0E00002A	Screw M2 x 3 Cylinder Head	2
03	0C03934A	Memory SW. Knob	1			Spacer	
04	0B07051A	Memory SW.	1	AH01115A	PH Spacer t = 0.1mm		
05	0C03931A	Counter Holder	1	AH01116A	PH Spacer t = 0.15mm		
06	0B03924A	Test Pin	2	AH01117A	PH Spacer t = 0.2mm		
07	0B07640A	Reed SW. P.C.B.	1	AH01118A	PH Spacer t = 0.25mm		
08	0B03803A	Reed SW.	1	AH01119A	PH Spacer t = 0.3mm		
09	0C03932A	Reed SW. Holder	1				
L01	0E00166A	Screw M2 x 4 Cylinder Head	2				
L02	0E00612A	Screw M3 x 6 Philips Pan Head (2A)	4				

10. WIRING DIAGRAM

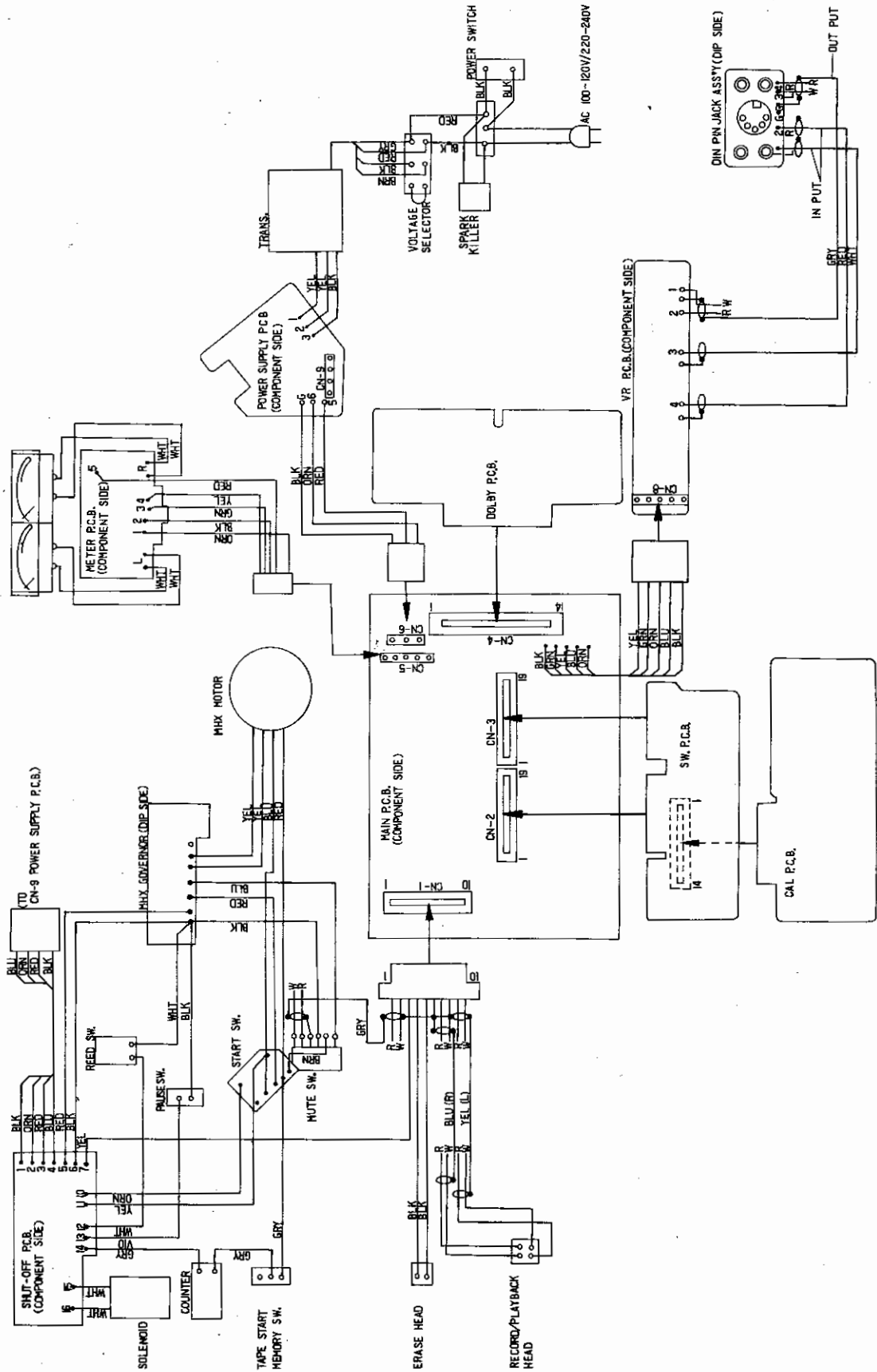

Fig. 10

11. EQ. AMP. FREQUENCY RESPONSE

11.1. Playback Frequency Response

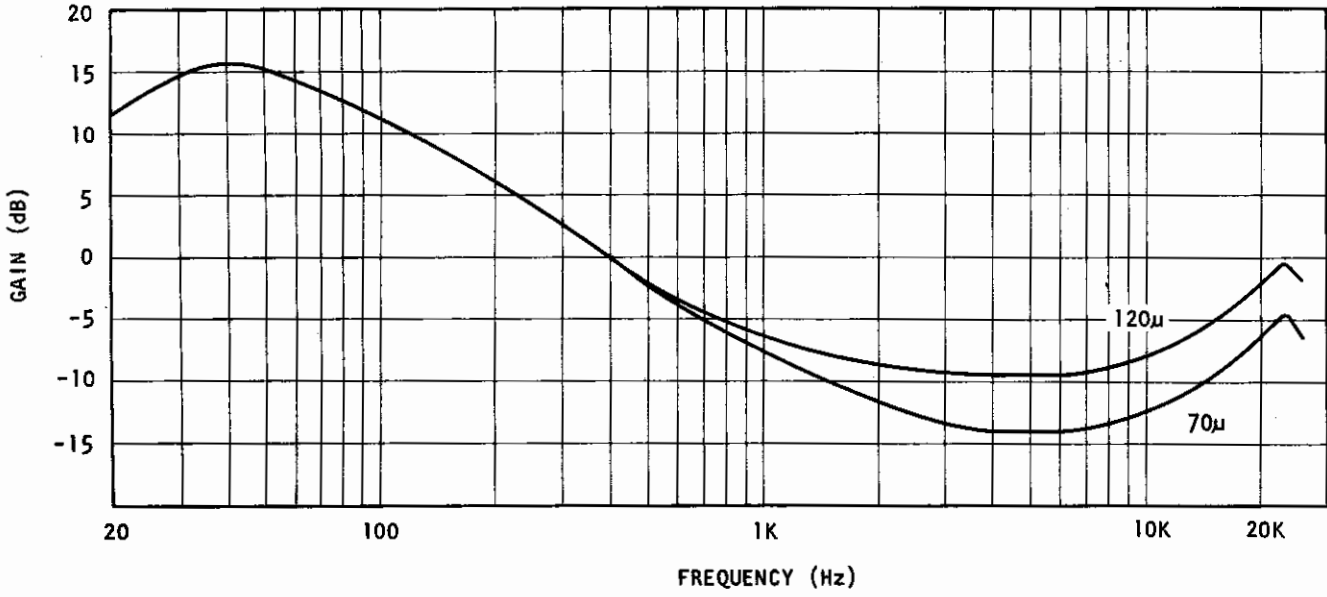

Fig. 11. 1

11.2. Record Current Frequency Response

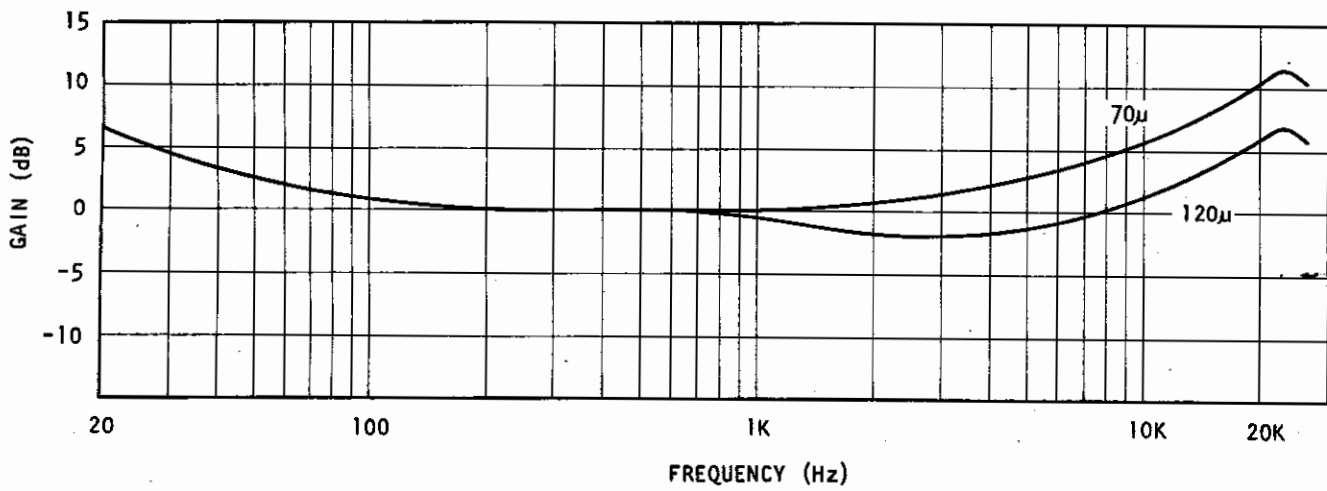

Fig. 11. 2

12. BLOCK DIAGRAM

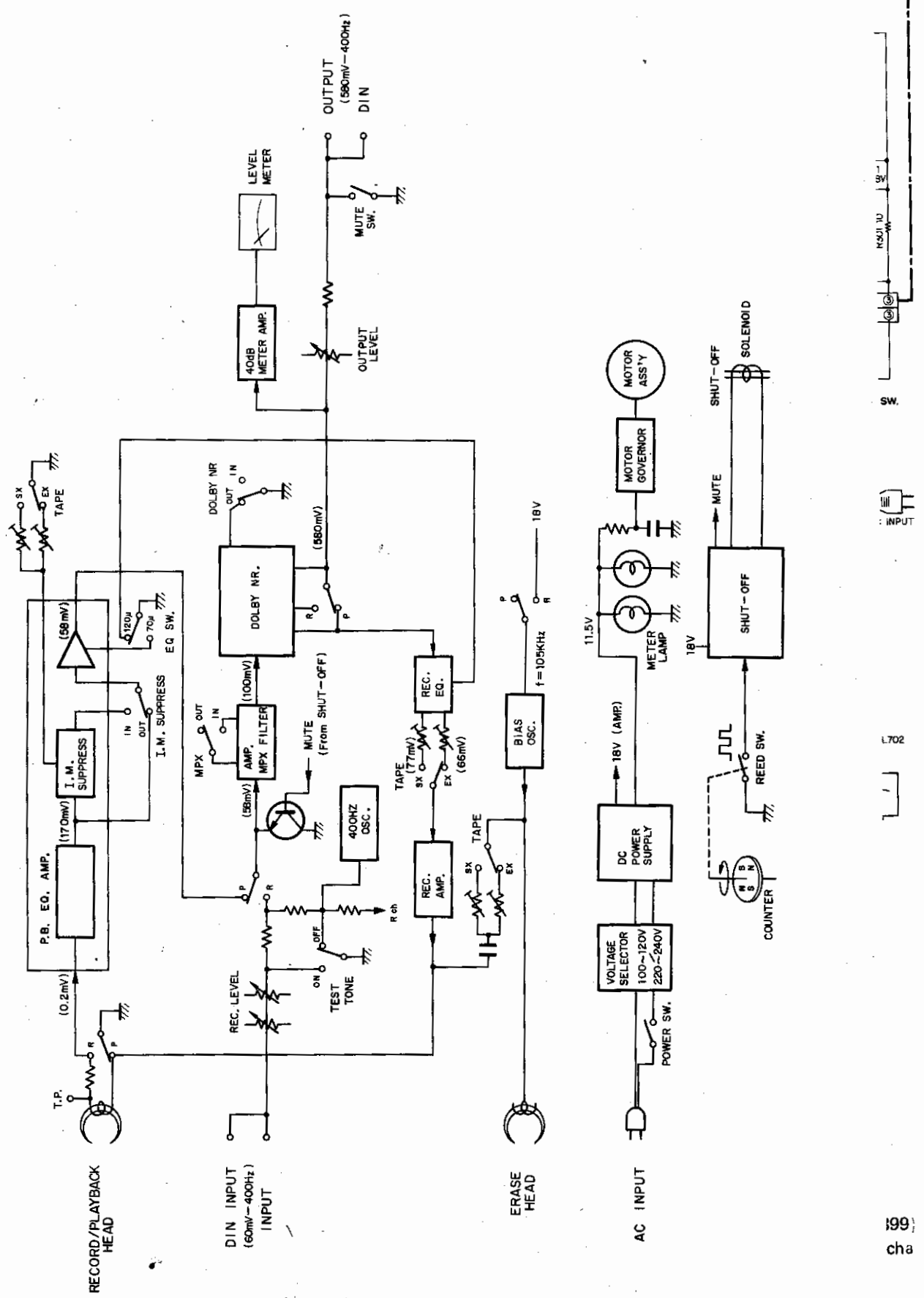
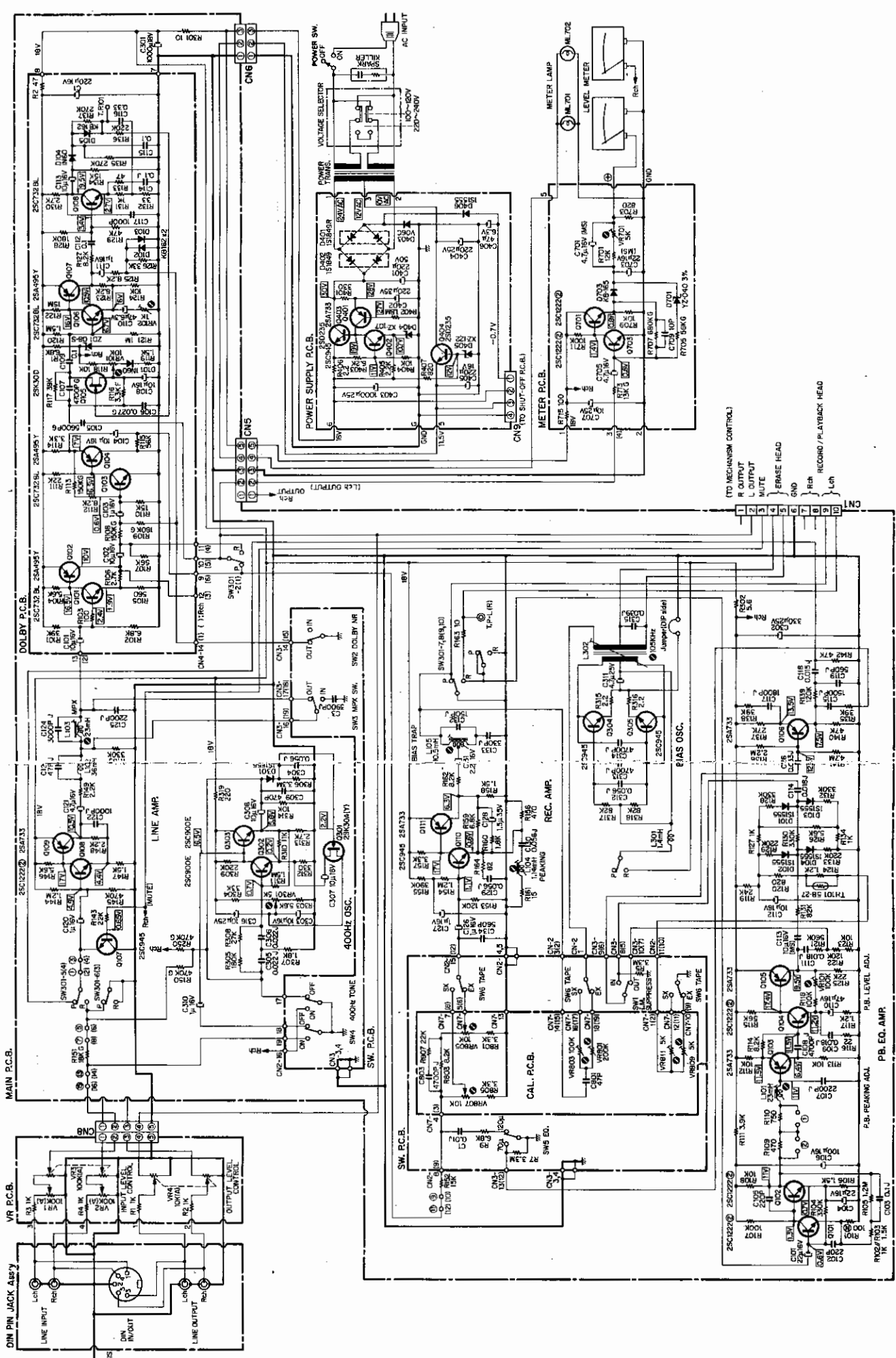

Fig. 12

13. SCHEMATIC DIAGRAM (AMP.)



Note:

- (1) () Shows a R channel's terminal No.
- (2) R channel circuits are omitted when R channel circuit are equal to the L channel.
- (3) On Meter P.C.B., CAL. P.C.B., SW. P.C.B. and VR P.C.B. (part reference Nos. 000-099, 700-799, 800-899), odd numbers show L channel's parts and even numbers show R channel's parts. For example R701 is an L channel's resistor and omitted R702 is an R channel's resistor.
- (4) Part reference Nos. 300-399, 400-499, 500-599, 600-699 show common parts for both channels.

Fig. 13

14. SCHEMATIC DIAGRAM (MECHANISM)

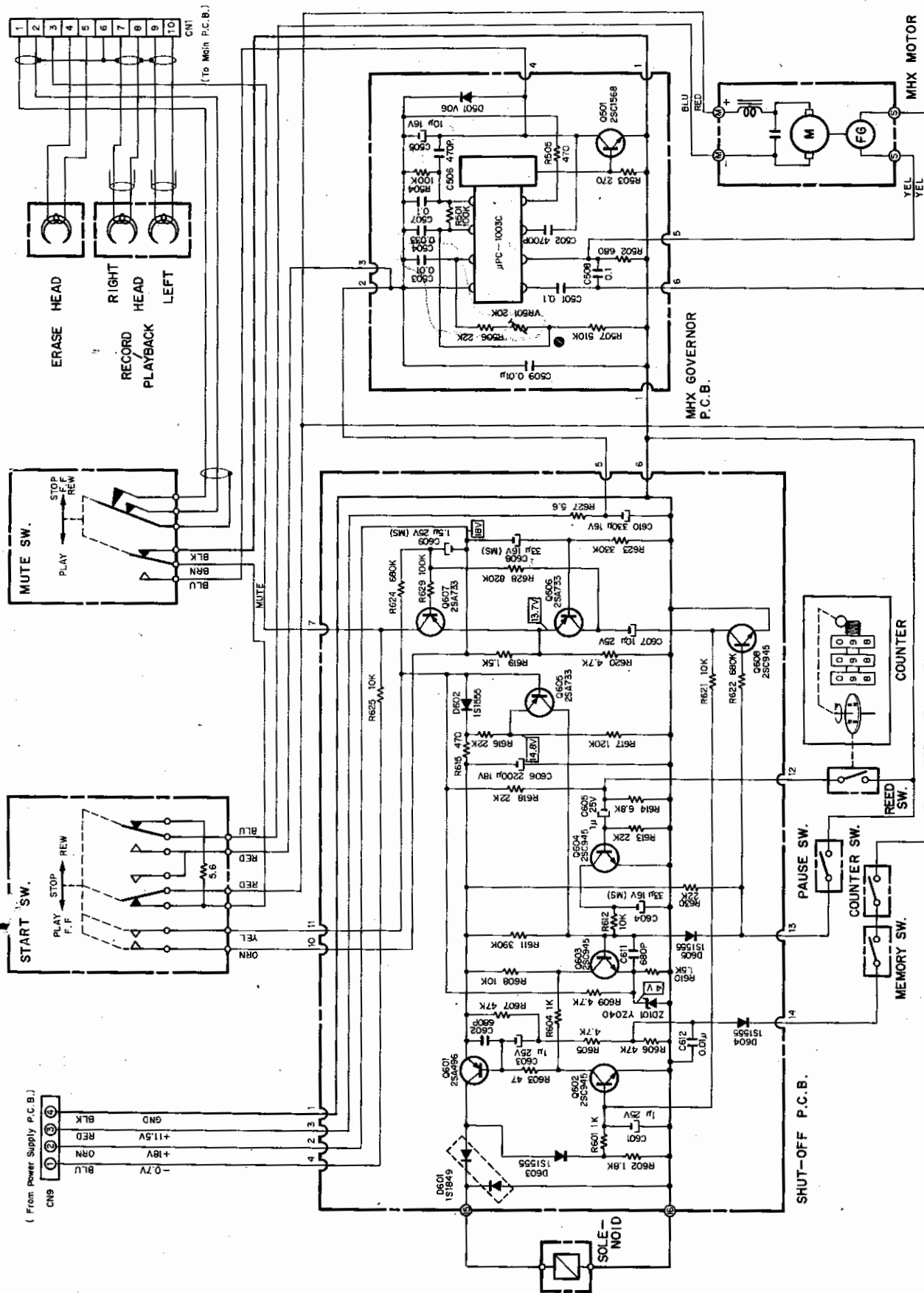

Fig. 14

15. SPECIFICATIONS

Power Source	100-117, 220-240V 50/60Hz
Power Consumption	15W Max.
Tape Speed	1-7/8 ips. (4.76cm/sec.) $\pm 1\%$
Wow and Flutter	Less than 0.12% WTD Peak
Frequency Response	40-18,000Hz ± 3 dB (SX, EX Tapes, -20dB Rec. Level)
Signal to Noise Ratio (Dolby In, SX Tape, WTD)	Better than 60dB 400Hz, 0dB WTD rms. Better than 68dB 400Hz, 3% THD WTD rms. with IM Suppressor
Total Harmonic Distortion	Less than 1.5% 400Hz 0dB Less than 0.5% 400Hz 0dB with IM Suppressor-In (SX, EX II Tapes)
Erase	Better than 60dB below saturation level at 1KHz
Separation	Better than 35dB, 1KHz, 0dB
Crosstalk	Better than 60dB, 1KHz, 0dB
Bias Frequency	105KHz
Transistors	57
Diodes	27
IC's	1
Input	50 Kohms, 60mV
Output Level	580mV (400Hz, 0dB, Output Level at Max.)
Dimensions	15.75 (W) x 6.70 (H) x 9.33 (D) inches 400 (W) x 170 (H) x 237 (D) m/m
Approximate Weight	14.3 lbs. (6.5 Kgs)

* Specifications and appearance design are subject to change for further improvement without notice.

16. TROUBLE SHOOTING

16.1. Note

- (1) Check to insure whether the outputs +18V, +11.5V and -0.7V (approximately) of the power supply are correct.
- (2) When a check is made on Amplifier, etc. by means of an extension cord, re-adjustment shall be made without fail (after final installation to the model chassis).
The check without removal of an extension cord will cause inaccurate adjustments.
- (3) When an adjustment is made on 19KHz MPX. filter, Bias trap coil, Peaking coil and/or Bias frequency, remove Meters and Meter Holder before start of adjustment.
- (4) Either Nakamichi SX or EX II tape shall be used while adjustment (particularly while adjustments of bias and record/playback level).
Should another different branded tape be used in its place, the machine shall previously be adjusted according to each of the actual tapes in use.
However, if a low quality tape should be used, optimum quality of machine will not be obtained (such as Distortion, Signal to Noise Ratio, Dynamic Range, etc. will be deteriorated).

- (5) Depress the pause button during Play or Fast-forward. The tape could be stopped but the motor is still rotating.
Depress the pause button during rewind, and this time the motor and tape are always in rewind mode (the tape keeps rotating).
- (6) When Flywheel is replaced, clean the Capstan before start of the operation (with alcohol-dipped cloth).

16.2. Trouble Shooting

16.2.1. Motor does not rotate:

- (1) Defective Motor.
- (2) Defective Motor Governor.
- (3) Defective Start Switch Ass'y.
- (4) Defective Mute Switch Ass'y.
- (5) Wire between Motor and Motor Governor is cut.
- (6) Wire between Motor Governor and Start Switch Ass'y is cut, etc.
- (7) +11.5V is not being supplied to the Motor Governor.

16.2.2. No power transmission:

- (1) Defective Power Cord.
- (2) Defective Power Switch.
- (3) Defective Power Transformer.
- (4) Defective D.C. Power Supply Circuit Board.
- (5) Defective Voltage Select Switch.

16.2.3. Sound is distorted:

- (1) Incorrect adjustment of Bias against tape.
- (2) Record/Playback Head is dirty.
- (3) Incorrect adjustment of I.M. suppressor.
- (4) Defective cassette tape.
- (5) Record/Playback Head is magnetized.
- (6) Weak Bias oscillation or does not oscillate.
- (7) Defective Record/Playback Head.
- (8) Excessively high level at Record/Playback.

16.2.4. High Frequency is deteriorated while playback:

- (1) Incorrect adjustment of Record/Playback Head azimuth.
- (2) Record/Playback Head is dirty.
- (3) Record/Playback Head is magnetized.
- (4) Excessive Wow/Flutter.
- (5) Inaccurate tape travel.
- (6) Defective Record/Playback Head.

16.2.5. High Frequency is deteriorated while record/playback:

- (1) Incorrect adjustment of Bias against tape (excessive bias current to the record/playback head).
- (2) Defective cassette tape.
- (3) Defective Record/Playback Head.

16.2.6. Does not playback:

- (1) Record/Playback Head is dirty.
- (2) Record/Playback Head is defective (open circuit or short circuit).
- (3) Defective Playback Amplifier.
- (4) Mute is not released.
- (5) Defective Mute Switch.
- (6) Defective Dolby N.R. Circuit Board.
- (7) Defective Output Buffer Amplifier.
- (8) Defective Record Switch.
- (9) Defective Output Jack.
- (10) Wire between Record/Playback Head and Playback Amplifier is cut.

16.2.7. Does not record:

- (1) Defective Bias Circuit.
- (2) Defective Erase Head (open circuit or short circuit).
- (3) Defective Record/Playback Head (open circuit or short circuit).
- (4) Record/Playback Head is dirty.
- (5) Defective Dolby N.R. Circuit Board.
- (6) Mute is not released.
- (7) Defective Record Amplifier.
- (8) Defective Record Switch.
- (9) Defective Record Link Ass'y.
- (10) Wire between Record/Playback Head and Record Amplifier is cut.
- (11) Defective Input Amplifier and/or Input Jack.
- (12) Inaccurate tape travel.

16.2.8. Excessive Wow/Flutter:

- (1) Defective Flywheel Ass'y.
- (2) Defective Motor.
- (3) Defective Motor Governor.
- (4) Defective Drive Belt.
- (5) Defective Pressure Roller Ass'y.
- (6) Defective Idler Pulley Ass'y.
- (7) Slippage between Pressure Roller and tape.
- (8) No clearance between Flywheel Ass'y and Flywheel Holder Ass'y.
- (9) Defective Cassette Tape (hard to rotate).
- (10) Defective Tape Counter (hard to rotate or sticky, etc.).
- (11) Excessive Back-tension.
- (12) Irregular Take-up Torque.

16.2.9. Does not erase or incomplete erasure:

- (1) Erase Head is dirty.
- (2) Defective Erase Head (open circuit or short circuit).
- (3) Inaccurate tape travel.
- (4) Weak Bias oscillation or does not oscillate.
- (5) Excessively high frequency of Bias oscillator.
- (6) Wire between Erase Head and Bias oscillator is cut.

16.2.10. Auto Shut-off does not work at end of tape:

- (1) Defective Auto Shut-off Detector.
- (2) Defective Auto Shut-off Driver.
- (3) Defective Solenoid Driver.
- (4) Defective Deck Button (hard to operate).
- (5) Wire between Solenoid and Driver is cut.
- (6) Incorrect adjustment of Solenoid.

x

16.2.11. Auto Shut-off activates at position other than tape end:

- (1) Defective Auto Shut-off Detector.
- (2) Defective Auto Shut-off Driver.
- (3) Defective Solenoid Driver.
- (4) Defective Counter.
- (5) Defective Counter Belt.
- (6) Defective Cassette Tape (hard to rotate).

16.2.12. Meters do not flutter:

- (1) Defective Meter (open circuit or short circuit).
- (2) Defective Meter Circuit.
- (3) Wire between Meter and Meter Circuit is cut.
- (4) Tape does not playback (playback mode).
- (5) Meter lead is shorted.
- (6) Defective Input Amplifier.

16.2.13. Defective tape travel:

- (1) Record/Playback Head is misaligned against Capstan.
- (2) Pressure Roller is misaligned against Capstan.
- (3) Excessive Take-up Torque.
- (4) Pressure of Pressure Roller is weak.
- (5) Erase Head is misaligned against Capstan.
- (6) Defective Capstan (bent, etc.).
- (7) Defective Capstan Flange (bent, etc.).
- (8) Reference Pin is bent.
- (9) Head Base is bent.
- (10) Incorrect adjustment of Record/Playback Head position.
- (11) Defective Erase Head.
- (12) Defective Pressure Roller.

16.2.14. Pause button does not release:

- (1) Defective Shut-off Solenoid.
- (2) Defective Solenoid Driver.
- (3) Defective Solenoid Linkage.

16.2.15. Tape does not rotate:

- (1) Defective Motor.
- (2) Defective Motor Governor.
- (3) Defective Drive Belt.
- (4) Drive Belt is out of place.
- (5) Defective Reel Hub.
- (6) Defective cassette tape (hard to rotate).
- (7) Incorrect loading of cassette tape.
- (8) Pressure Roller is not in contact with Capstan.

16.2.16. Drive Belt is out of place:

- (1) Motor is misaligned.
- (2) Idler Pulley Ass'y is misaligned.
- (3) Excessive clearance between Flywheel Ass'y and Flywheel Holder Ass'y.
- (4) Defective Drive Belt.

16.2.17. Signal to Noise Ratio is deteriorated:

- (1) Record/Playback Head is magnetized.
- (2) Excessive Bias Leakage.
- (3) Record/Playback Head is dirty.
- (4) Defective Record/Playback Head.
- (5) Defective cassette tape.
- (6) Defective D.C. Power Supply Board (excessive ripple).
- (7) Defective Input Amplifier (noise is great).
- (8) Defective Output Amplifier (noise is great).
- (9) Incorrect adjustment of hum balance wire.

16.2.18. Channel separation is deteriorated:

- (1) Incorrect tape travel.
- (2) Defective Record/Playback Head.

16.2.19. Tape speed is too fast or slow:

- (1) Defective Motor.
- (2) Defective Motor Governor.
- (3) Pressure Roller is not in contact with Capstan.
- (4) Defective Mute Switch (contacting chassis).
- (5) Defective cassette tape (hard to rotate).

16.2.20. Does not Eject:

- (1) Defective Eject Linkage Arm.
- (2) Defective Stop/Eject Button.
- (3) Eject Linkage Arm is out of place.
- (4) Defective cassette tape.

16.2.21. Level variations:

- (1) Incorrect tape travel.
- (2) Record/Playback Head is dirty.
- (3) Defective Record/Playback Head.
- (4) Record/Playback Head is misaligned.
- (5) Defective cassette tape.
- (6) Incorrect adjustment of Head Base stroke.

16.2.22. Bias does not oscillate:

- (1) No voltage to Bias oscillation circuit.
- (2) Defective Bias oscillation circuit.
- (3) Defective Erase Head (open circuit or short circuit).

16.3. Check method when parts are replaced.

When any part/part ass'y of the Nakamichi 600 is replaced with new one, please check to insure the following.

16.3.1. When Motor is replaced:

- (1) Tape speed.
- (2) Wow/Flutter.
- (3) Drive Belt position (out of place).

16.3.2. When Drive Belt is replaced:

- (1) Drive Belt position (out of place).
- (2) Tape speed.
- (3) Wow/Flutter.

16.3.3. When Record/Playback Head is replaced:

- (1) The inclination of a Record/Playback head.
- (2) Azimuth/Height.
- (3) Tape Travelling.
- (4) Playback output.
- (5) Playback frequency response.
- (6) Overall frequency response.
- (7) Distortion.
- (8) Signal to Noise Ratio.
- (9) Channel separation.

16.3.4. When Erase Head is replaced:

- (1) Tape travelling.
- (2) Azimuth/Height (record/playback head).
- (3) Bias frequency.
- (4) Erasure.
- (5) Overall frequency response.

16.3.5. When Flywheel Ass'y is replaced:

- (1) Clearance between Flywheel and Flywheel Holder.
- (2) Tape travelling.
- (3) Azimuth/Height.
- (4) Tape speed.

16.3.6. When Pressure Roller is replaced:

- (1) Tape travelling.
- (2) Azimuth/Height.
- (3) Tape speed.
- (4) Wow/Flutter.
- (5) Pressure Roller timing.

16.3.7. When Tape Counter is replaced:

- (1) Tape speed.
- (2) Wow/Flutter.
- (3) Memory rewind operation.
- (4) Counter check (sticky, etc.).
- (5) Auto shut-off operation.

16.3.8. When Reel Hub Ass'y is replaced:

- (1) Torque check (take-up, fastforward and/or rewind).
- (2) Tape speed.
- (3) Wow/Flutter.

16.3.9. When Deck Button Ass'y is replaced:

- (1) Button operation.
- (2) Head base stroke.
- (3) Pause switch operation.
- (4) Record switch operation.
- (5) Mute switch operation.
- (6) Start switch operation.

16.3.10. When Idler Pulley Ass'y is replaced:

- (1) Drive Belt position (out of place).
- (2) Tape speed.
- (3) Wow/Flutter.
- (4) Rewind time.
- (5) Fastforward time.
- (6) Brake Timing.

16.3.11. When Motor Governor is replaced:

- (1) Tape speed.
- (2) Wow/Flutter.

16.3.12. When Level Meter is replaced:

- (1) Meter level.
- (2) Meter check (sticky, etc.).

16.3.13. When Solenoid is replaced:

- (1) Solenoid position.

16.3.14. When Record Link Ass'y is replaced:

- (1) Record Link ass'y adjustment (height).

Service Manual

Nakamichi 600

NAKAMICHI RESEARCH INC.

1-153 Suzukicho, Kodaira, Tokyo

Phone: (0423) 42-1111

Telex: 2832610. (NAKREI J)

Cable: NAKREI KKB

NAKAMICHI RESEARCH (U.S.A.) INC.

West Coast Office

1101 Colorado Avenue,

Santa Monica, Calif. 90401

Phone: (213) 451-5901

Telex: 65249 (NAKREI SNM)

NAKAMICHI RESEARCH (U.S.A.) INC.

New York Office

220 Westbury Avenue,

Carle Place, N.Y. 11514

Phone: (516) 333-5440

Telex: 144513 (NAKREI CAPL)