

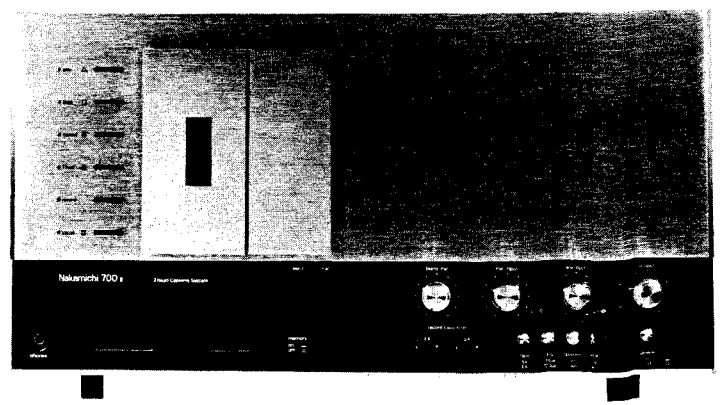

Service Manual

Nakamichi 700II 3 Head Cassette System



CONTENTS

1.	General	4
2.	Principle of Operation	6
2.	1. Mechanisms	6
	2.1.1. 3-Head Configuration	6
	2.1.2. Double Capstan Tape Drive	6
	2.1.3. Ball Drive Mechanism	7
2.	2. Amp. Circuits	8
	2.2.1. Record Dolby NR Circuit	8
	2.2.2. Playback Dolby NR Circuit	9
	2.2.3. Playback Head Amp.	11
	2.2.4. MIC Amp., DIN Amp., Mixing Amp. and MPX Filter	12
	2.2.5. Record Equalizer Amp.	13
	2.2.6. Bias Osc. and 400 Hz Osc.	14
	2.2.7. Meter Amp. and Line Amp.	15
	2.2.8. Power Supply	16
2.	3. Mechanism Control Circuits	17
	2.3.1. Logic Control	17
	2.3.2. Shut-off Sensor and Detector	21
	2.3.3. Azimuth Alignment Detector	22
	2.3.4. Capstan Motor Governor	24
	2.3.5. Reel Motor Governor	25
	2.3.6. Head Base Solenoid Driver	25
	2.3.7. Brake Solenoid Driver	25
3.	Removal Procedures	26
3.	1. Cassette Lid Ass'y and Adjust Lid Ass'y	26
3.	2. Cabinet Ass'y	26
3.	3. Front Panel Ass'y	26
3.	4. Touch Switch Ass'y	26
3.	5. Head Mount Base E Ass'y	26
3.	6. Pressure Roller Ass'y	26
3.	7. Head Base Solenoid Ass'y	26
3.	8. Flywheel Ass'y and Capstan Belt	26
3.	9. Brake Solenoid Ass'y	26
3.	10. Eject Damper Bracket Ass'y	26
3.	11. Ball Drive Mechanism Ass'y	26
3.	12. Shut-off Ass'y	26
3.	13. Reel Motor Ass'y	26
3.	14. Rear Panel Ass'y and Transformer	26
3.	15. Reel Motor Governor Ass'y	27
3.	16. Base Switch Ass'y	27
3.	17. Capstan Motor Ass'y	27
3.	18. Logic Control P.C.B. Ass'y	27
3.	19. Front Control P.C.B. Ass'y and Switch P.C.B. Ass'y	27
3.	20. PB Head Amp. P.C.B. Ass'y, PB Dolby NR P.C.B. Ass'y and Record Dolby NR P.C.B. Ass'y	27
3.	21. Main P.C.B. Ass'y	27
3.	22. DC Power Supply P.C.B. Ass'y	27
3.	23. 400 Hz Osc. Switch P.C.B. Ass'y	27
4.	Check-out Procedures	28
4.	1. Check-out Procedures for Inspection	28
4.	2. Check Methods	29
4.	3. Check Methods When Part(s) is(are) Replaced	30
5.	Measurement and Maintenance Instruments	31
5.	1. Measurement Instrument and Connection	31
5.	2. Maintenance Instrument	32
6.	Mechanical Adjustments	33
6.	1. Torque Adjustment	33

6.1.1.	Torque Measurement	33
6.1.2.	Torque Adjustment	33
6.1.3.	Ball Drive Mechanism Ass'y Adjustment	33
6.1.4.	Ball Drive Mechanism Ass'y Replacement Procedures	33
6.	2. Tape Speed	34
6.	3. Head Base Damper Adjustment	34
6.	4. Eject Damper Adjustment	35
6.	5. Headblock	35
6.5.1.	Head Mount Base Ass'y Removal Procedures	35
6.5.2.	Head Replacement Procedures	36
6.5.3.	Tape Guide Height Adjustment	37
6.5.4.	Head Height Adjustment	37
6.5.5.	Tape Travelling Check	37
6.5.6.	Playback Head Track Alignment	38
6.5.7.	Playback Head Azimuth Alignment	38
6.5.8.	Record Head Height Alignment	38
6.5.9.	Erase Head Adjustment	38
6.	6. Flywheel Adjustment	38
6.	7. Tape Travelling Adjustment	39
6.7.1.	Check-out Method	39
6.7.2.	Adjustment	39
6.	8. Lubrication	39
7.	Electrical Adjustments and Measurements	40
7.	1. Adjustments and Measurements Table	40
7.	2. Meter Level Calibration	41
7.	3. 400 Hz Test Tone	41
7.	4. 19 kHz MPX Filter	41
7.	5. Playback Level Calibration	41
7.	6. Playback Frequency Response	42
7.	7. Head Azimuth Alignment (Playback Head)	42
7.	8. Bias Oscillator Frequency	42
7.	9. Bias Trap (Bias Leakage)	42
7.9.1.	Record Amp. Bias Trap	42
7.9.2.	Playback Amp. Bias Trap	43
7.	10. Recording Equalization Peaking	43
7.	11. Alignment Beacon Phase Adjustment	43
7.	12. Record Bias and Record/Playback Level	44
7.	13. Record Dolby NR Alignment	45
7.	14. Playback Dolby NR Alignment	45
7.	15. Frequency Response Adjustment	45
7.15.1.	Playback Frequency Response	45
7.15.2.	Overall Frequency Response	46
7.	16. Signal-to-Noise Ratio Measurement	47
7.	17. Channel Separation Measurement	47
7.17.1.	Left Channel to Right Channel	47
7.17.2.	Right Channel to Left Channel	47
7.	18. Crosstalk Measurement	47
7.	19. Erasure Measurement	47
7.	20. Total Harmonic Distortion Measurement	47
7.	21. Wow/Flutter Measurement	47
8.	Parts Location for Electrical Adjustment	48
9.	Mounting Diagram and Parts List	49
9.	1. Main P.C.B. Ass'y	49
9.	2. Playback Dolby NR P.C.B. Ass'y	51
9.	3. Record Dolby NR P.C.B. Ass'y	52
9.	4. Playback Head Amp. P.C.B. Ass'y	53

9.	5.	Switch P.C.B. Ass'y	54
9.	6.	Front Control P.C.B. Ass'y	56
9.	7.	DIN Amp. P.C.B. Ass'y	56
9.	8.	Record Cal. P.C.B. Ass'y	56
9.	9.	Capstan Motor Governor P.C.B. Ass'y	57
9.	10.	Reel Motor Governor P.C.B. Ass'y	57
9.	11.	Shut-off Sensor P.C.B. Ass'y and Shut-off Luminous P.C.B. Ass'y	57
9.	12.	400 Hz Osc. Switch P.C.B. Ass'y	58
9.	13.	Head Base Switch P.C.B. Ass'y	58
9.	14.	Brake Solenoid P.C.B. Ass'y	58
9.	15.	Logic Control P.C.B. Ass'y	60
9.	16.	Touch Switch P.C.B. Ass'y	60
9.	17.	Power Supply P.C.B. Ass'y	61
10.		Mechanism Ass'y and Parts List	62
10.	1.	Synthesis (A01)	62
10.	2.	Chassis Ass'y (A02)	63
10.	3.	Cabinet Ass'y (A03)	64
10.	4.	Front Panel Ass'y (A04)	65
10.	5.	Mechanism Ass'y 700II	66
	10.5.1.	Mechanism Ass'y 700II (1/4) (A05-1)	66
	10.5.2.	Mechanism Ass'y 700II (2/4) (A05-2)	67
	10.5.3.	Mechanism Ass'y 700II (3/4) (A05-3)	68
	10.5.4.	Mechanism Ass'y 700II (4/4) (A05-4)	69
10.	6.	Rear Panel Ass'y (B01)	70
10.	7.	Head Mount Base E Ass'y (B02)	71
10.	8.	Auto Shut-off Ass'y (B03)	72
10.	9.	Mount Base Cover Ass'y (B04)	72
10.	10.	Meter Chassis Ass'y (B05)	72
10.	11.	Ball Drive Mechanism Ass'y (B06)	73
10.	12.	Cassette Well Ass'y 37 (B07)	73
10.	13.	Head Base Solenoid (B08)	73
10.	14.	Brake Solenoid Ass'y (B09)	73
10.	15.	Flywheel Holder Ass'y (B10)	74
10.	16.	Capstan Motor Ass'y (B11)	74
10.	17.	Eject Damper Bracket Ass'y (B12)	76
10.	18.	Cassette Holder Ass'y (B13)	76
10.	19.	Memory Switch Ass'y (B14)	76
10.	20.	Base Switch Ass'y (B15)	76
10.	21.	Pressure Roller Arm D Ass'y B (C01)	76
10.	22.	Cassette Spring Ass'y L (C02)	76
10.	23.	Cassette Spring Ass'y R (C03)	76
10.	24.	Record Head Ass'y (C04)	76
10.	25.	Playback Head Ass'y (C05)	76
11.		Wiring Diagram	77
11.	1.	Amplifier	77
11.	2.	Mechanism	78
12.		Block Diagram	79
12.	1.	Amplifier	79
12.	2.	Mechanism	80
13.		Level Diagram	81
14.		Eq. Amp. Frequency Response	81
15.		Schematic Diagram	82
15.	1.	Amplifier	82
15.	2.	Mechanism	83
15.	3.	Capstan Motor Governor	84

16. Troubleshooting 84
 16. 1. Notes 84
 16. 2. Troubleshoots 84
 17. Specifications 88

1. GENERAL

Nakamichi 700II control functions are shown with reference to the following explanations.

To maintain the optimum performance of the Nakamichi 700II, maintenance such as cleaning of head, capstan shaft and pressure roller, and demagnetization of head, lubrication, etc. are required.

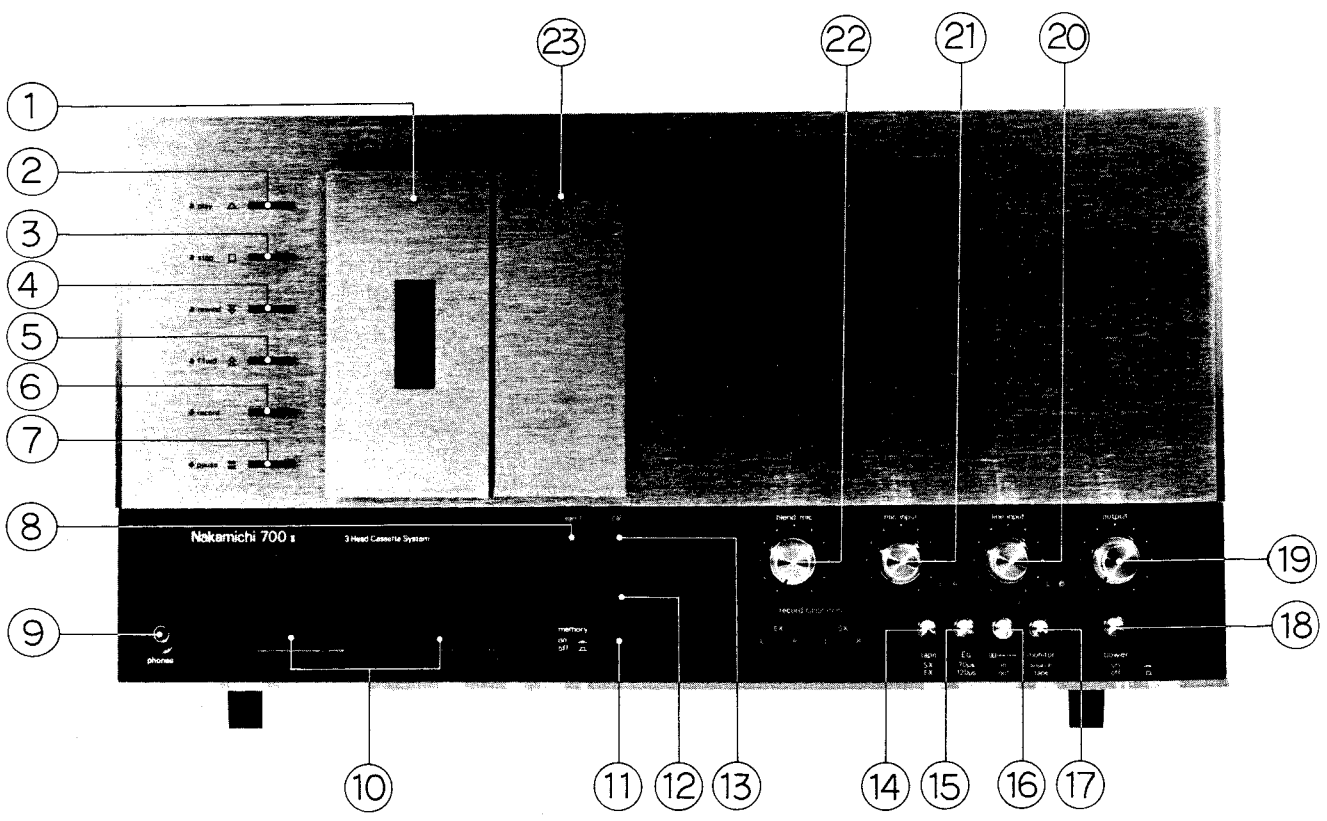

Fig. 1.1 Front View

- | | |
|------------------------------|--------------------------------|
| 1. Cassette Lid | 13. Adjustment Lid Button |
| 2. Playback Button | 14. Tape Selector Switch |
| 3. Stop Button | 15. Eq Selector Switch |
| 4. Rewind Button | 16. Dolby NR Switch |
| 5. Fast Forward Button | 17. Monitor Switch |
| 6. Record Button | 18. Power Switch |
| 7. Pause Button | 19. Line Output Level Controls |
| 8. Eject Button | 20. Line Input Level Controls |
| 9. Headphone Jack | 21. MIC Input Level Controls |
| 10. Peak Level Meters | 22. Blend MIC Level Control |
| 11. Tape Start Memory Switch | 23. Adjustment Lid |
| 12. Index Tape Counter | |

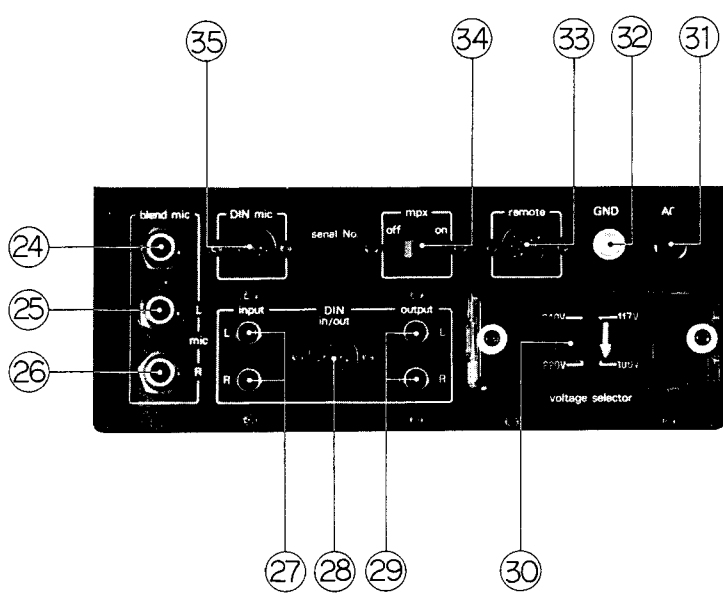

Fig. 1.2 Top View

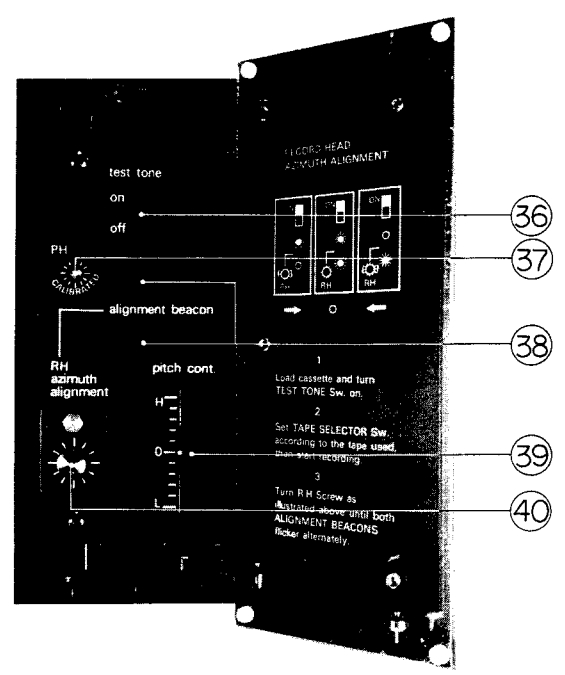

Fig. 1.3 Adjustment Panel

- 24. Blend MIC Input Jack
- 25. MIC Input Jack L
- 26. MIC Input Jack R
- 27. Line Input Jacks
- 28. DIN In/Out Socket
- 29. Line Output Jacks
- 30. Voltage Selector Plug
- 31. AC Power Supply Cord
- 32. Ground Terminal
- 33. Remote Control Socket
- 34. 19 kHz MPX Filter Switch
- 35. DIN MIC Input Socket
- 36. Test Tone Switch
- 37. Playback Head Azimuth Alignment Screw
- 38. Alignment Beacon
- 39. Pitch Control
- 40. Record Head Azimuth Alignment Screw

Voltage Selector

Change-over either to 100, 117, 220, or 240 V.

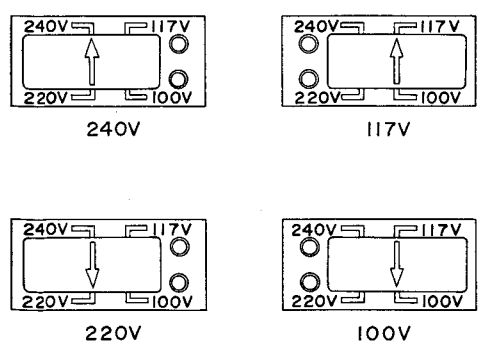

Fig. 1.4 Voltage Selector

Note: When a check is made on amp., etc. by means of an extension cord, re-adjustment shall be made without fail after final installation to the model chassis. The check without removal of an extension cord will cause inaccurate adjustments.

2. PRINCIPLE OF OPERATION

2.1. Mechanisms

2.1.1. 3-Head Configuration

Basically there are five openings in the cassette housing, and the both sides of openings are being used for left and right capstans and pressure rollers and the remaining three openings are for the two reference pins and the playback head in between. Nakamichi 1000 II and 700 II incorporate the 3-head system, and the playback head has a very narrow gap of 0.7 micron. In order to ensure the best possible frequency response particularly at the high-end the playback head should be positioned against the opening which will take advantage of the felt pad in the cassette housing as well as the shielding plate incorporated.

The record head gap is 5 micron for achieving the best bias and signal flux penetration to the tape and wide dynamic range in recording. The record head is of an exceptionally hard durable hi-Mu ferrite. With this configuration only the openings available for the separate erase and record heads are the openings of the take-up pressure roller side and the take-up reference pin side. One of the critical factors in the 3-head system is the adjustment of track width for the three independent heads. Instead of mounting the heads on the base plate of the mechanism the Nakamichi 1000 II and 700 II use quite a unique head mounting method; the three heads are hanged from the top of the head housing so that it enables an independent azimuth alignment on the three heads and the alignment becomes much easier since it can be performed with a screwdriver from the top of the head housing. See Fig. 2.1.1. If readjustment of the heads is necessary, it is highly recommendable to do the adjustment, referring to the Adjustment Procedures.

2.1.2. Double Capstan Tape Drive

As shown in Fig. 2.1.2, the double capstan system consists of two capstan shafts (a) and (b) connected to the two flywheels which are driven with a belt.

Against these capstans two pressure rollers (a) and (b) are engaged to run the tape with an adequate holdback tension created by the double capstan and pressure rollers. When the two capstan flywheels start rotating as shown in Fig. 2.1.2 the belt tension at side A becomes stronger than

that of the side B belt and the rotation of capstan (a) becomes slightly faster than that of the capstan (b). With the pressure rollers (a) and (b) pressed against the capstans (a) and (b) it creates a tension over the tape between the capstans in proportion to the difference in capstan rotation.

As the double capstan system always creates a constant and stable holdback tension between the two capstans, the condition of the tape between two capstans will not be affected by any external conditions such as irregular take-up and supply torque, irregular loading of cassette tape, undesirable mechanism vibration, etc., thus assuring the superior wow and flutter characteristic.

The double capstan system provides a constant holdback tension on the tape and maintains the stable pressure on the tape against the heads, therefore, the tape maintains the stable contact with the erase and record head surfaces even without the pads.

The only critical factor in the double capstan system is to be considered; the two capstans have to be positioned perfectly in parallel and to be precisely vertical against the heads base, the pressure rollers have to be evenly pressed against the capstan shafts and the head surface must be positioned perfectly vertical to the tape surface. Otherwise, the running tape might become out of the tape guide resulting in the irregular tape movement.

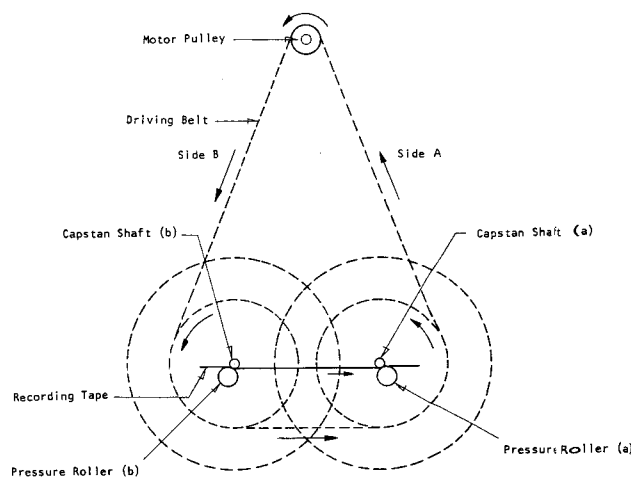

Fig. 2.1.2 Double Capstan Tape Drive

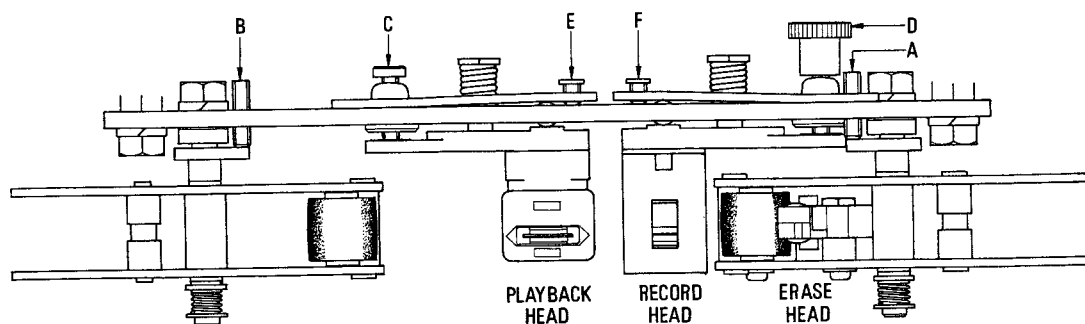

Fig. 2.1.1 3-Head Configuration

2.1.3. Ball Drive Mechanism

The Take-up Reel Hub and Supply Reel Hub are driven by a Reel Motor through the Ball Drive Mechanism.

Fig. 2.1.3 shows torque delivery, Fig. 2.1.4 shows the construction of the Ball Drive Mechanism, and Fig. 2.1.5 shows a cross-sectional view of the Take-up/Supply Block.

(1) Play Mode:

The Reel Motor is controlled by a governor and rotates at a constant speed. Through a belt, the torque of the Reel Motor is delivered to the Center Gear which will then rotate to the direction of "a" to communicate the torque to the Gears of both Take-up and Supply Blocks.

The Ball Clutch functions to rotate the Take-up Reel Hub to the direction of "c" at the Take-up Block as shown in the item (3). Namely, since the Ball in the Block is held between Clutch Pulley and Gear, the Clutch Pulley rotates to the same direction as the Gear does (to "c") and accordingly the Brake Drum Ass'y (i.e. Reel Hub) rotates through the Clutch Plate (a friction clutch) fitted to the Clutch Pulley. The Supply Reel Hub while in Play mode will become free as the gear torque of the Supply Block is not delivered to the Clutch Pulley.

(2) FF and REW Modes:

+12 V is directly fed to the Reel Motor, and the Center Gear rotates to the direction of "a" while in FF mode and to "b" direction while in REW. When the Center Gear rotates to the direction "a", the Ball Clutch of the Take-up Block functions to rotate the Take-up Reel in the same manner as in the Play mode. This way, a tape travels forwardly.

When the Center Gear rotates the other way round (to direction "b"), the Ball Clutch of the Supply Block functions to rotate the Supply Reel to the direction of "d". This way a tape is rewound. Meantime the Take-up Reel is released.

(3) Ball Clutch Mechanism:

Refer to Fig. 2.1.6. As shown in Fig. 2.1.5, a magnet ring is incorporated in the Take-up/Supply Block.

Since the magnetic force at the periphery is greater than that at the inner part, the Ball will stop in the state of being pushed to the Base B (Reel Hub Gear) (Fig. A).

When the Base B moves to the left hand side, the Ball will forcedly come in between the Bases A (having an angle of θ) and B, since the Ball have an appropriate friction against the Base B, as a result of which the Base A also commences to move (Fig. B).

When the Base B moves to the right direction, the Ball will part from the Base A, and this way the Bases A and B will become released (Fig. C).

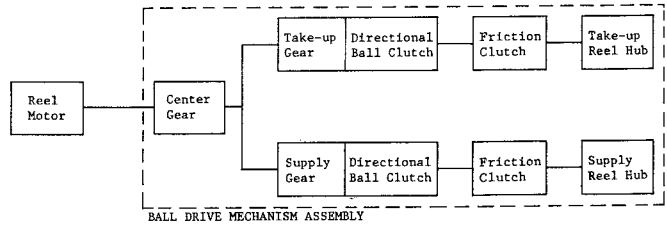

Fig. 2.1.3 Torque Delivery

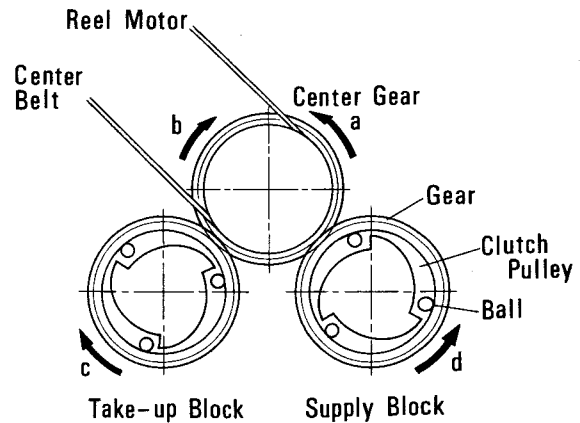

Fig. 2.1.4 Construction

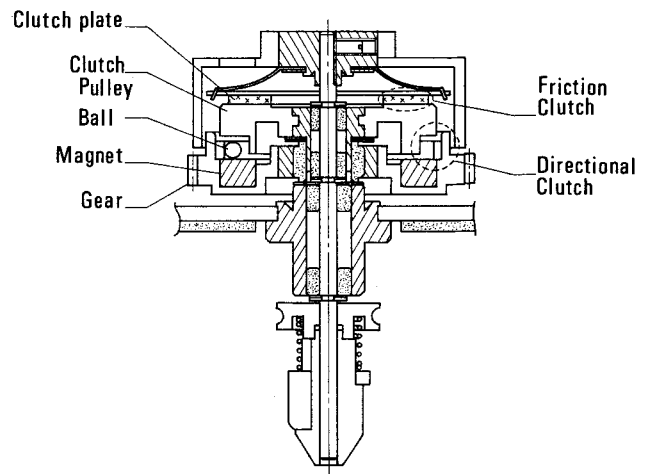

Fig. 2.1.5 Take-up/Supply Block Cross-sectional View

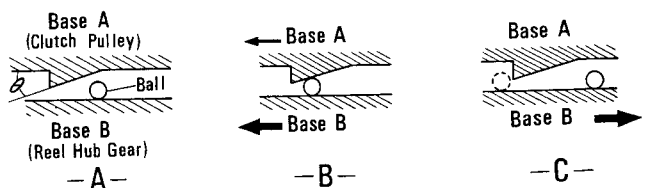

Fig. 2.1.6 Ball Clutch Model

2.2. Amp. Circuits

2.2.1. Record Dolby NR Circuit

Fig. 2.2.1 shows a recording mode Dolby NR processor circuit. The circuit input signal is applied through terminal 11 (4), while the signal applied through terminal 12 (3) is fed to the MONITOR switch and is only subjected to impedance conversion by Q101 and is not boosted by the Dolby NR processor. Terminal 10 (5) is the circuit output terminal and is linked with the REC. EQ. AMP via REC. CAL. VR and TAPE selection switches. Terminal 13 (2) is connected with the DOLBY NR switch. For DOLBY NR IN, this terminal becomes open and a feedback current is applied to the base of Q102. For DOLBY NR OUT, this terminal is grounded and the output via the emitter of Q102 is cut from the Dolby NR processor.

A detailed explanation of the Dolby NR processor can be found in other references, however, it is also briefly described here.

Fig. 2.2.2 compares input vs. output characteristics of the Dolby NR processor, where curve A shows the recording mode Dolby NR circuit and curve B the playback mode. The symmetry of these two characteristics with respect to line O-O', bisecting the right corner, is highly significant. Curve A for recording exhibits a linear relationship between the input and output signal levels from the high level down to -5 dB, under which the input level gradually bends. For input levels under -30 dB, the output level is boosted by 10 dB with respect to the input level. The action of the recording mode Dolby NR circuit is that the output level is boosted from 0 to a maximum of 10 dB according to the input level.

With curve B for playback, in contrast to that for recording, the output level decreases with a decrease in the input level and, for an input level of less than -30 dB, becomes a further 10 dB lower than this input level.

According to this characteristic, noise generated in the playback system, such as hiss noise, playback amplifier noise, etc., is reduced by 10 dB. Combination of the above for recording and playback mode results in a linear characteristic. For example, for a -40 dB recording input, point b on curve A is recorded at -30 dB since the input is boosted by 10 dB in the recording mode Dolby NR circuit. When the signal reproduced from a recorded magnetic tape enters the playback mode Dolby NR circuit, the -30 dB input level is reduced by 10 dB to -40 dB; point b' on curve B. Thus, the 1:1 proportional relation is valid for any input level.

This action is explained using a system diagram of the recording mode Dolby NR processor as shown in Fig. 2.2.3.

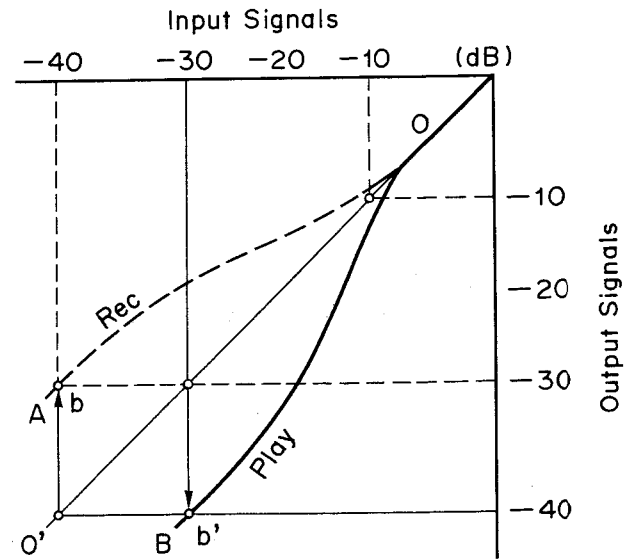

Fig. 2.2.2 Working Principle of Dolby NR Circuit

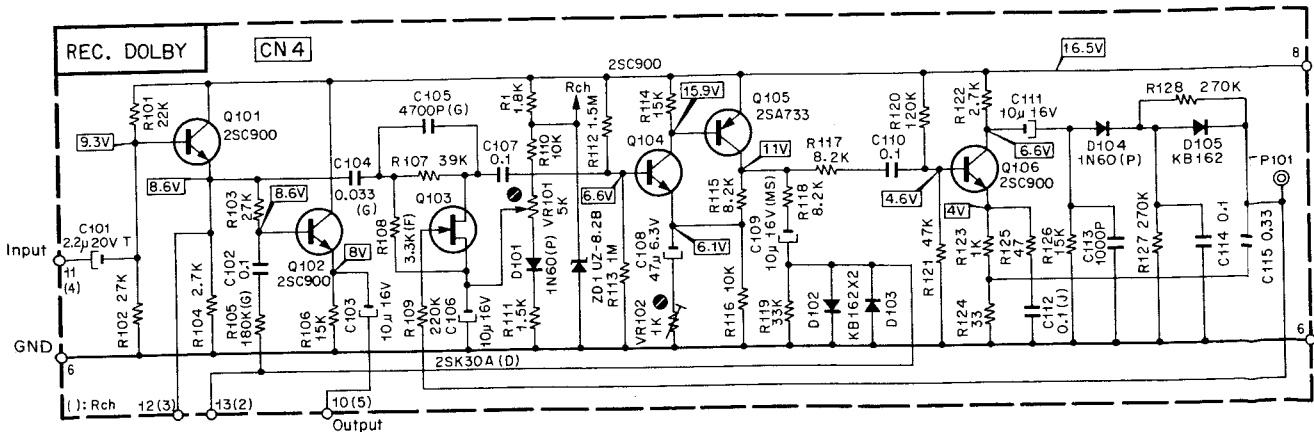

Fig. 2.2.1 Record Dolby NR Processor Circuit Diagram

The input signal enters the input of amplifier 4 (Q102) via amplifier 1 (Q101). Another signal from amplifier 1 is amplified by amplifier 2 (Q104 and Q105) after passing through a high-pass filter and enters amplifier 4. This signal is superposed by another signal as previously mentioned and this added signal is supplied to the output terminal through amplifier 4. The signal amplified by amplifier 3 (Q106) is fed back to an FET (Q103) after being rectified by diode D (D104). A circuit including the high-pass filter, amplifiers 2 and 3, and the FET in Fig. 2.2.3 is called a compressor, and the signal which appears at the point between the output of amplifier 2 and the input of amplifier 4 is called the compressor output signal (E_2). On the other hand, the output (E_1) of amplifier 1 is called the direct signal, and the FET is used as an electronic attenuator.

Indications such as 8.6 V, etc. in the circuit diagram show DC voltages when a zero signal is applied. The standard

input signal level to the recording mode Dolby NR processor is 100 mV at 400 Hz. The recording output signal level is about 85 mV (r.m.s.).

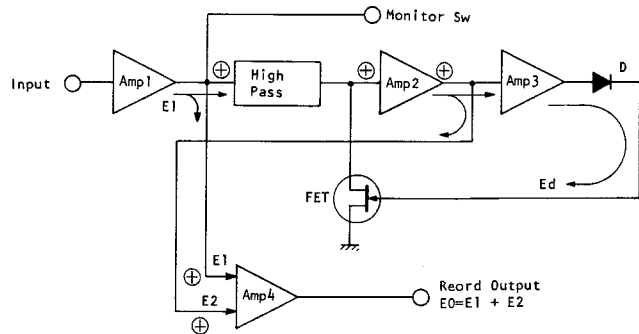

Fig. 2.2.3 Record Dolby NR Processor System Diagram

2.2.2. Playback Dolby NR Circuit

Fig. 2.2.4 shows a circuit diagram for a playback mode Dolby NR processor. The input for this circuit is applied through terminal 12 (3) where the output of the playback head amplifier is connected. Terminal 10 (5) is the output of the playback mode Dolby NR processor which becomes the input of the Buffer Amp. via the MONITOR switch. An input signal through terminal 13 (2) is applied to the DOLBY NR switch. For DOLBY NR IN, this line is open and the signal is fed back to the base of Q101. For DOLBY NR OUT, this line is grounded and no signal is fed back.

Since the general action of the Dolby NR processor is described in the preceding section, Rec. Dolby NR Circuit, only the action of the playback mode Dolby NR processor will be explained here, using its system diagram. The input signal applied through amplifier 1 (Q101, Q102) via a high-pass filter, is amplified in amplifier 2

(Q104, Q105), and is then fed back to the input of amplifier 1 in opposite phase to the phase of the input signal. Since this results in the subtraction of the feedback signal from the input signal, the resultant signal appears at the amplifier 1 output, i.e., the playback mode Dolby NR processor. Meanwhile, an output signal which has been amplified by amplifier 3 (Q106) controls the FET (Q103) after being rectified by diode D (D104).

The difference between playback and record is, as is obvious from the above explanation, that the phase of the compressor signal is opposite to that of the direct signal because of the changed signal path. Fig. 2.2.6 shows typical record and playback mode frequency characteristics for the Dolby NR processor. According to this figure, it is obvious that frequency components higher than about 200 Hz are subjected to the Dolby NR process at levels less than about -10 dB.

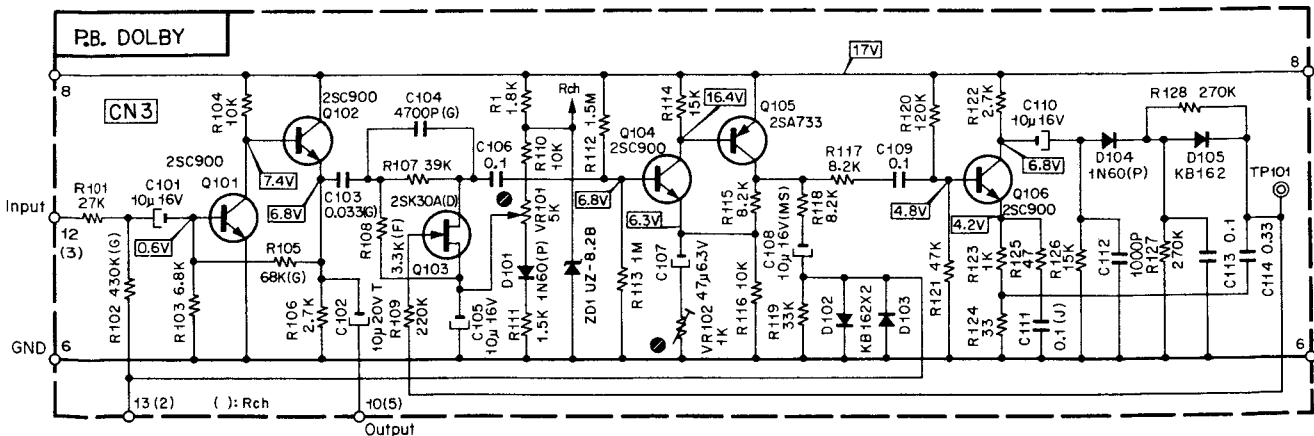

Fig. 2.2.4 Playback Dolby NR Processor Circuit Diagram

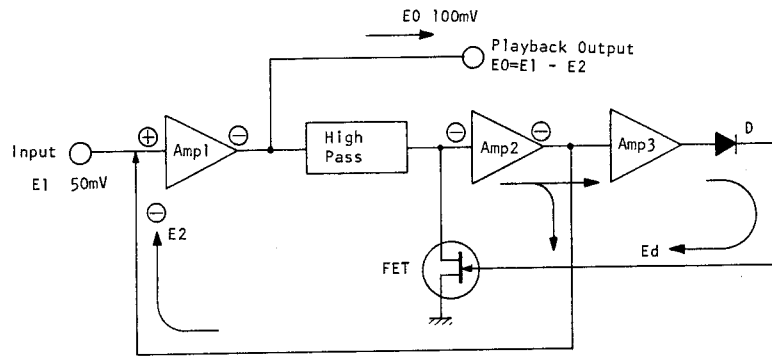

Fig. 2.2.5 Playback Dolby NR Processor System Diagram

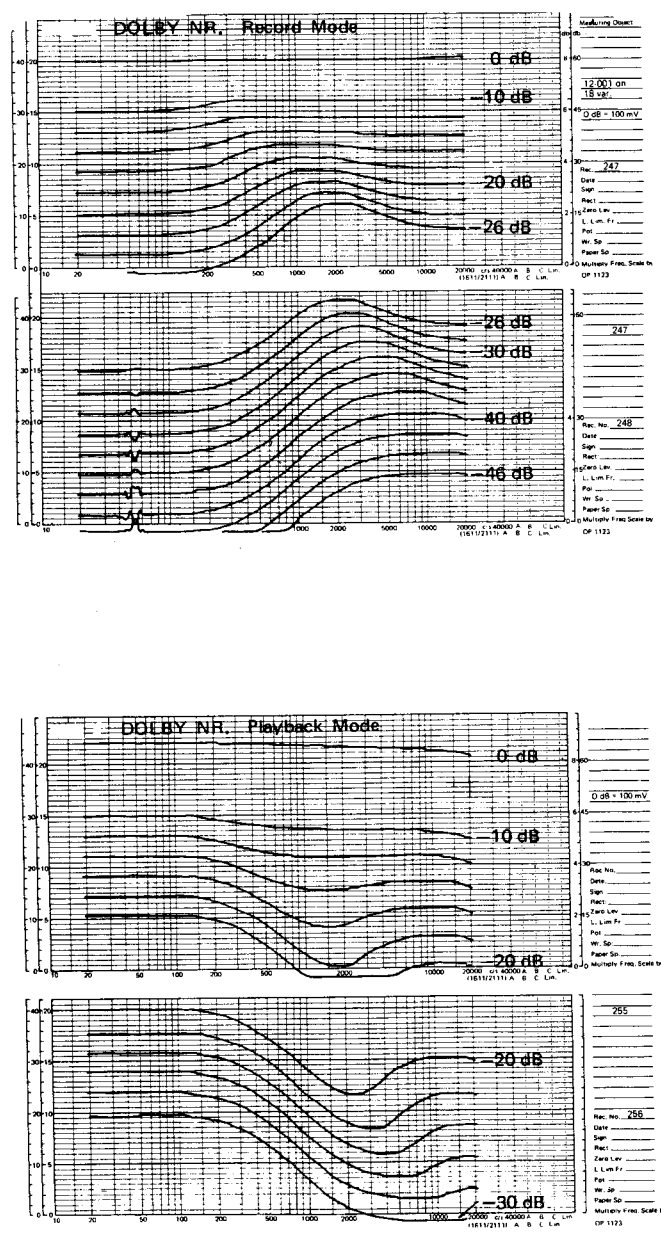

Fig. 2.2.6 Dolby NR Processor Record/Playback Frequency Response

2.2.3. Playback Head Amp.

Fig. 2.2.7 shows the playback amplifier circuit, and Fig. 2.2.8 is its system diagram. The playback head is connected with terminals 13 (11) and 14 (12). Terminal 4 is provided for the mute signal. Terminal 6 (8) and 7 are connected with the EQ switch which is used to select a time constant according to the characteristics of the magnetic tape used.

Amplifier 1 (Q101 and Q102) is an equalizer amplifier. With the selection of the equalizer constants of its feedback circuit by means of a jumper wire, its time constant on the high frequency side can be varied in 10 μ s steps from 110 μ s to 140 μ s and its gain in 1 dB steps. This selection is provided for compensation of playback head characteristics, however, the time constant of 120 μ s is usually selected by short-circuiting R108 (10 k Ω) and opening R109 (22 k Ω).

Time constants of the time constant circuit are selected by 120 μ s and 70 μ s positions of the EQ switch so that the frequency characteristics of the circuit will fit to those

of the magnetic recording tape used as follows (the time constant at low frequency is fixed to 3180 μ s):

EX11 3180 μ s (50 Hz) + 120 μ s (1326 Hz)

SX 3180 μ s (50 Hz) + 70 μ s (2274 Hz)

The FET (Q103) acts to prevent transference of the amplifier 1 output signal to phase-shifter (Q104) by reducing its gate voltage below the pinch-off voltage for the mute signal.

Phase-shifter (Q104) acts to compensate the phase delay characteristics of the frequency response, reducing the modulation for the complex wave.

The playback amplifier gain is adjusted by VR101 in amplifier 2 (Q105, 106) so that, when the 400 Hz 20 mM/mm recorded tape is played back the output voltage of the playback mode Dolby NR processor at terminal 5 becomes 100 mV and that of the playback head amplifier at terminal 3 (2) about 50 mV. The L and C in the amplifier 2 output provide a filter for bias-trapping which prevents disturbance of the Dolby NR action due to mixing bias frequencies in the Dolby NR processor.

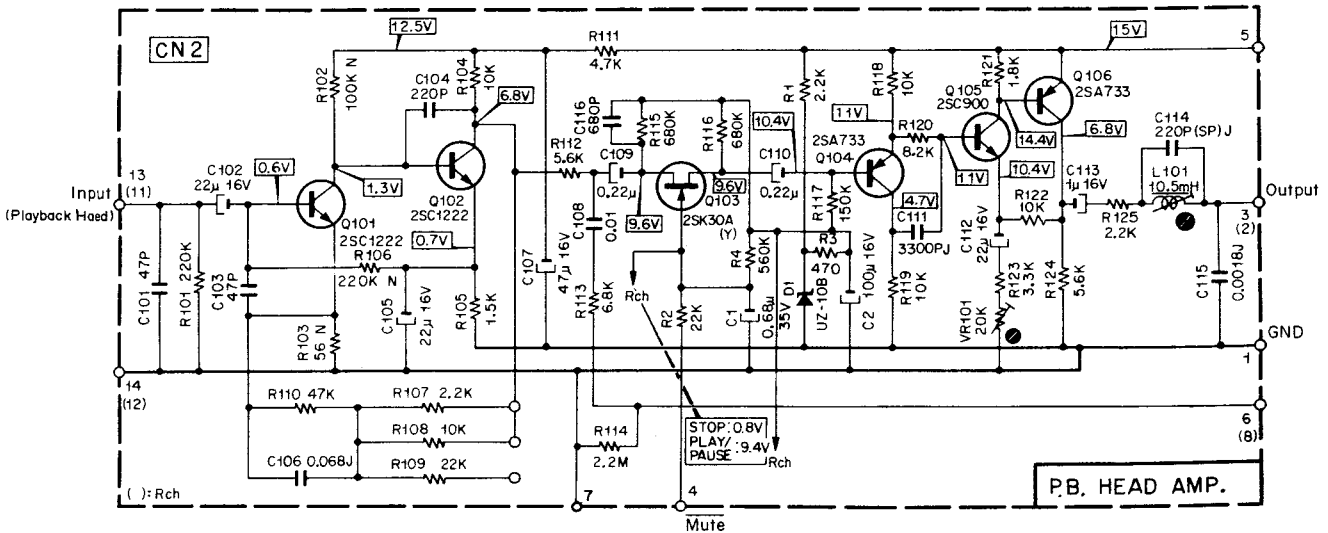

Fig. 2.2.7 Playback Head Amp. Circuit Diagram

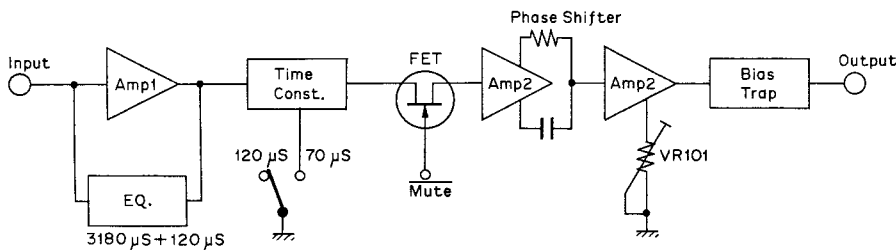

Fig. 2.2.8 Playback Head Amp. System Diagram

2.2.4. MIC Amp., DIN Amp., Mixing Amp. and MPX Filter

Fig. 2.2.9 shows a MIC Amp., DIN Amp., Mixing Amp. and MPX Filter (MPX Filter is incorporated in the Main P.C.B.).

(1) DIN Amp.

Input sensitivity of the DIN Amp. is 0.19 mV/kΩ. By plugging the DIN Jack, line input is disconnected and DIN Amp. output signal is fed to the Mixing Amp.

(2) MIC Amp.

Microphone amplifier (MIC AMP): Since the signal level of this input is usually low, Q701, Q702 and Q703 are provided to broaden the dynamic range. Q703 is a constant current source which provides a high MIC amp. output impedance.

For a large microphone output, this circuit is used at a reduced MIC VOLUME. In this case, however, the voltage gain of Q702 decreases because the load resistance of Q702 is reduced. Since voltage gain of the conventional microphone amplifier is constant, its amplification characteristics are not good for large input signals and its dynamic margin is about 40 dB. However, the microphone amplifier described here can be used without distortion for input voltages up to 2 V because of its broad dynamic margin which is greater than approximately 80 dB. Thus,

no microphone attenuator is necessary. If neither a DIN microphone nor a microphone plug is connected, the output of this circuit is grounded.

The blending microphone circuit (BLEND MIC) is the same as the microphone amplifier.

The voltage values indicated as 0.2 mV, 5 mV, etc., at the input terminals of the circuit board show that when each VOLUME control on the panel concerned is set at its maximum position, the LEVEL METER indicates 0 dB for each of these values. The output of this circuit is combined with the input of the mixing amplifier.

(3) Mixing Amp.

Q704, Q705 and Q706 consist of a mixing amplifier. Q704 performs impedance conversion for line input, and the outputs of Q704 and MIC Amp. are mixed by the Q705 and Q706.

(4) MPX Filter

The output signal from the mixing amplifier is fed to the LC filter. This filter normally operates the Dolby NR by removing the leakage of the bias signals for recording and the FM broadcast multicarrier signals. L154 is adjusted to minimize the 19 kHz signal level for MPX switch IN.

The output of this circuit, 100 mV, becomes the input of the recording mode Dolby NR processor.

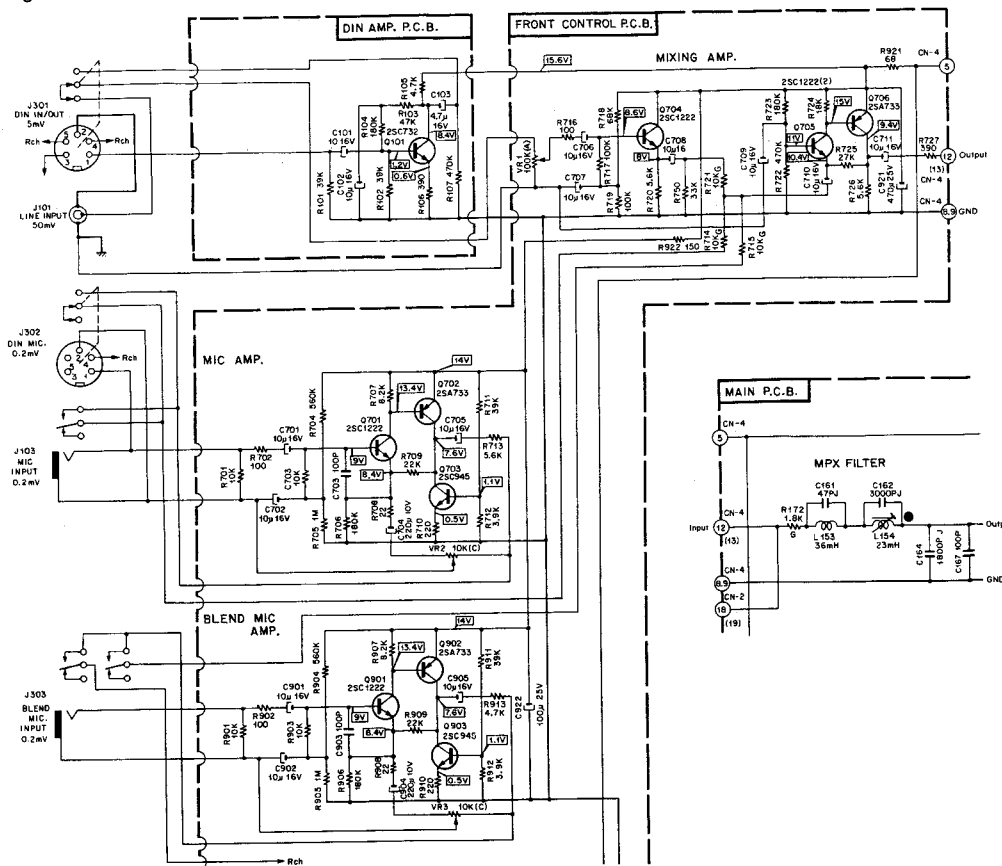

Fig. 2.2.9 MIC Amp., DIN Amp., Mixing Amp. and MPX Filter Circuit Diagram

2.2.5. Record Equalizer Amp.

Fig. 2.2.10 shows the recording calibrator variable resistor circuit (REC CAL VR) and the recording equalizer amplifier circuit (REC EQ AMP).

This signal from the output of the recording mode Dolby NR processor becomes the input of this RECORDING EQ circuit. The recording head (REC HEAD) is connected between the output terminal of this circuit and the ground. (A 10Ω resistor is inserted in series to the ground side.)

The VR101 line is prepared for EX tape and that of VR102 for SX tape. The time constant is selected by changeover of this EQ switch. This selection, coupled with the time constant selection in the Playback Head Amplifier (PB HEAD AMP), makes it possible to obtain characteristics suitable for tape types. With respect to the

details of this part, the section on the playback head amplifier should be referred to.

Since the FET (Q151) is in the OFF state for mute, the signal is cut here and no signal exists in the equalizer amplifier circuit. Without the mute signal, Q151 is in the ON state. Thus, the signal from the RECORDING CALIBRATION is amplified by Q152 and Q153. And a constant current flows through the RECORDING HEAD over all frequencies used. L151 and C158 compose the recording equalizer. Compensation for the high frequency range is made by building a resonance frequency at about 23 kHz by means of adjusting L151. L152 and C159 construct a bias trap.

Fig. 2.2.11 and 2.2.12 show the frequency characteristics of recording and playback.

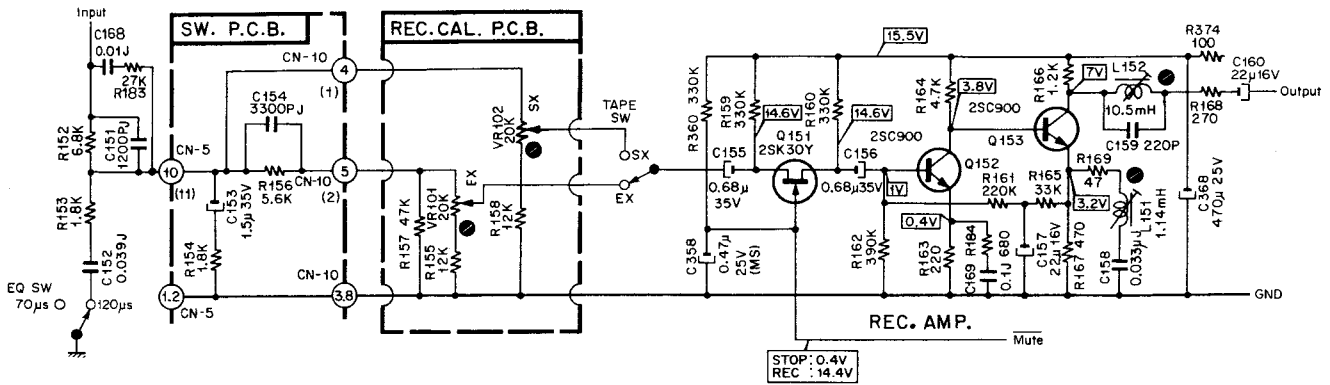

Fig. 2.2.10 Record Eq. Amp. Circuit Diagram

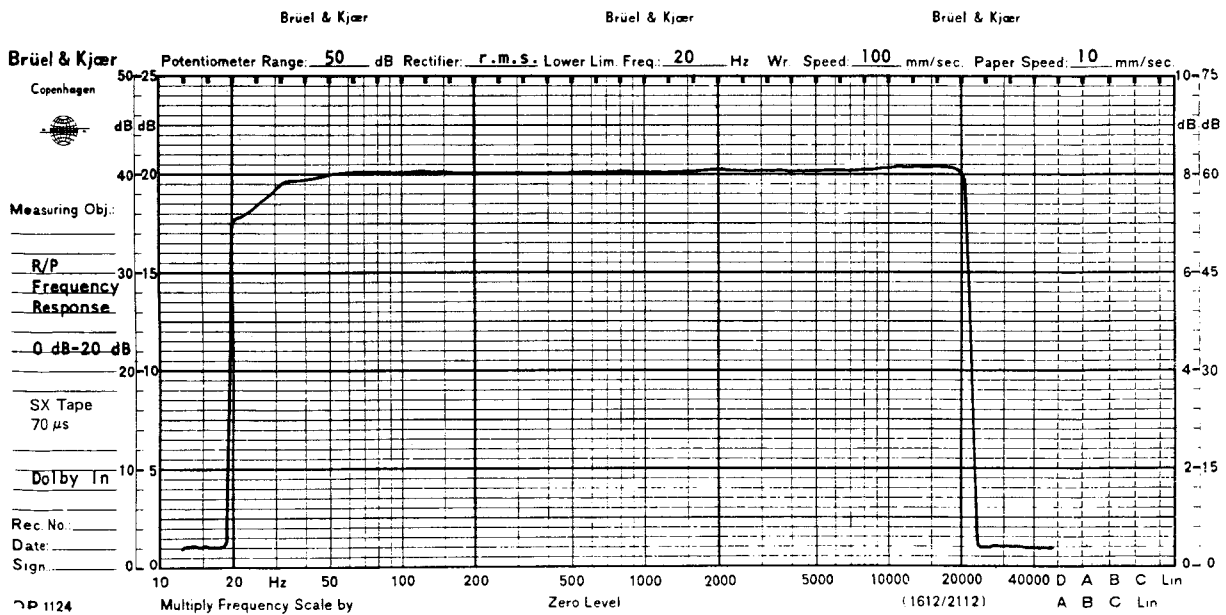

Fig. 2.2.11 Record/Playback Frequency Response (Dolby NR: IN)

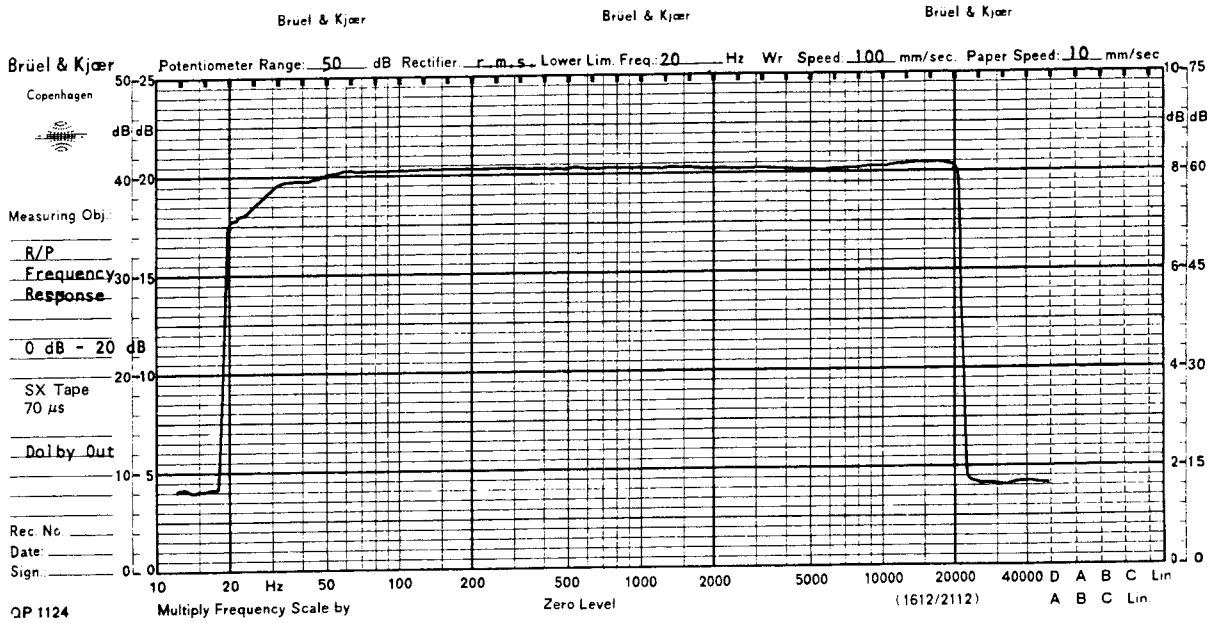

Fig. 2.2.12 Record/Playback Frequency Response (Dolby NR: OUT)

2.2.6. Bias Osc. and 400 Hz Osc.

Fig. 2.2.13 shows a push-pull oscillator with an oscillation frequency of 105 kHz which is constructed by capacitors C353 and C354 decoupling the collectors and bases of two transistors.

This is used to provide recording bias and as an erase signal.

By touching on the REC button, the record signal turns to high through the logic board, Q354 is put in the ON state,

the bias oscillator power supply is activated, and oscillation begins. When the record mode is released, oscillator output is damped by the discharge of C351. This prevents magnetization of the head.

Fig. 2.2.14 shows a 400 Hz oscillator circuit using an RC circuit. Its signal output is used to check record and playback levels and as an alignment beacon. VR351 is used for adjusting oscillation amplitude.

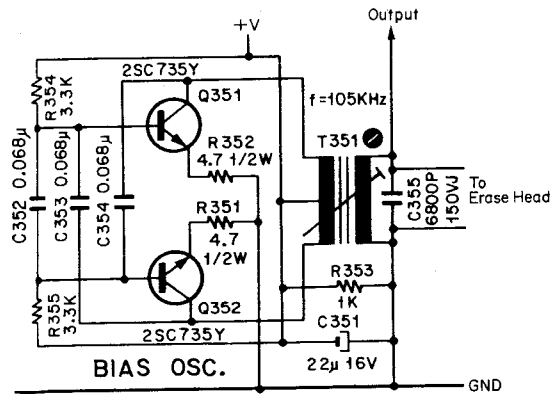

Fig. 2.2.13 Bias Osc. Circuit Diagram

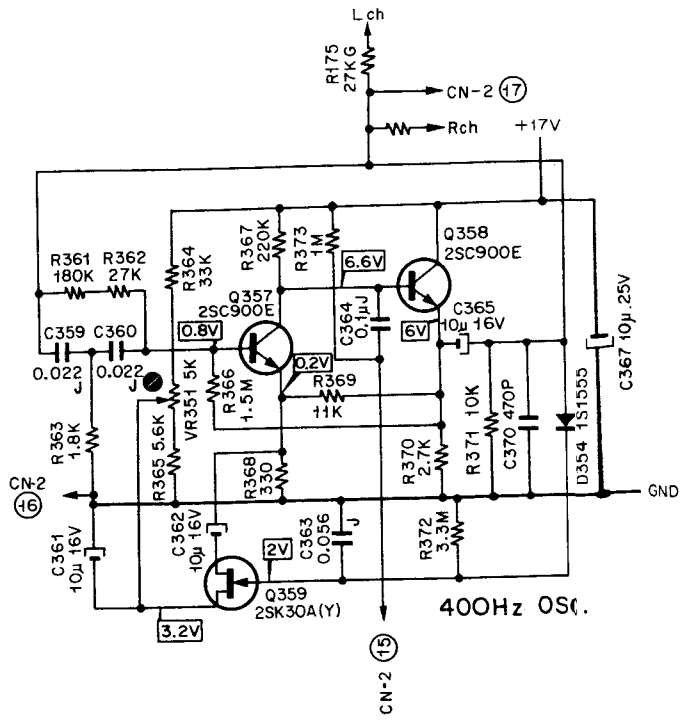

Fig. 2.2.14 400 Hz Osc. Circuit Diagram

2.2.7. Meter Amp. and Line Amp.

Fig. 2.2.15 shows the level meter amplifier circuit and the line output amplifier. Terminal CN4-6(7) is the input of the level meter amplifier.

Q154 and Q155 form a directly-coupled-feedback amplifier and for a low input level, feedback occurs through R180. For high input levels which exceed the Zener voltage of diode D151, feedback magnitude increases by adding a feedback through R181 to that through R180, and the output gain decreases. That is, high input signals are subjected to compression during amplification. This circuit is so designed that its attack time is 20 μ s and its release time is about 140 msec. Thus, even if sharp peaks

such as those encountered in live music exist, the level meter indicates correct peak values. The input of the line output amplifier is connected to the MONITOR switch and its level is controlled by the OUTPUT VOLUME control. The signal amplified by Q707 and Q708 is fed to a shunt regulated push-pull circuit composed of Q709 and Q710, and a maximum output of approximately 1000 mV is obtained from line terminal. Since the output impedance is low, long cords are available for connection and no deterioration of characteristics occur due to multiple connections to recorders, etc. A circuit composed of Q711, 712, 713 and 714 is designed for a headphone with an 8 ohm impedance.

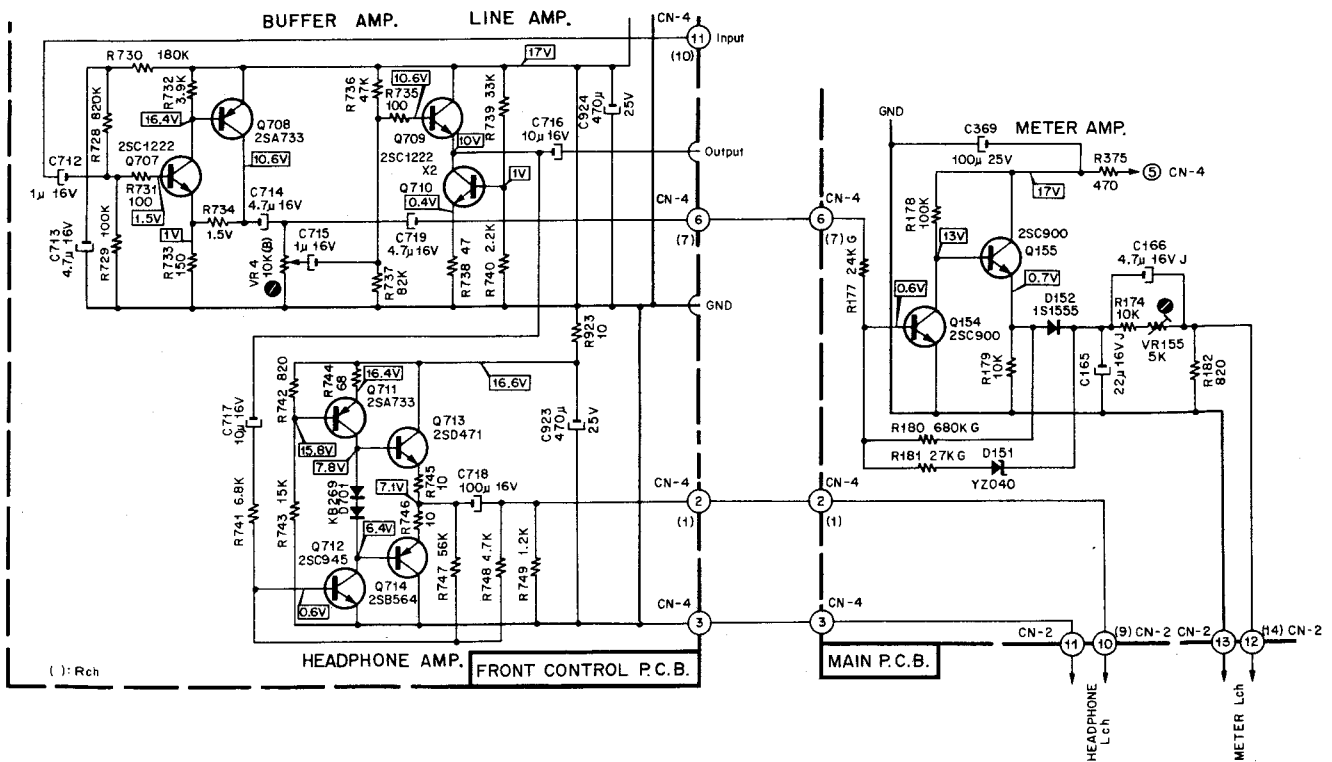

Fig. 2.2.15 Meter Amp. and Line Amp. Circuit Diagram

2.2.8. Power Supply

Fig. 2.2.16 shows the power supply circuit. This power supply is designed so that a constant voltage is obtained at the output on the secondary side of transformer [T1] for 100/117/220/240 V AC inputs by changing the VOLTAGE SELECTOR plug.

The 17 V DC, 0.5 A output is used as a power supply for the amplifier system, and the 12 V DC, 1.5 A output for the mechanism control. The 6 V AC, 0.3 A output is the power supply for illuminating the level meter.

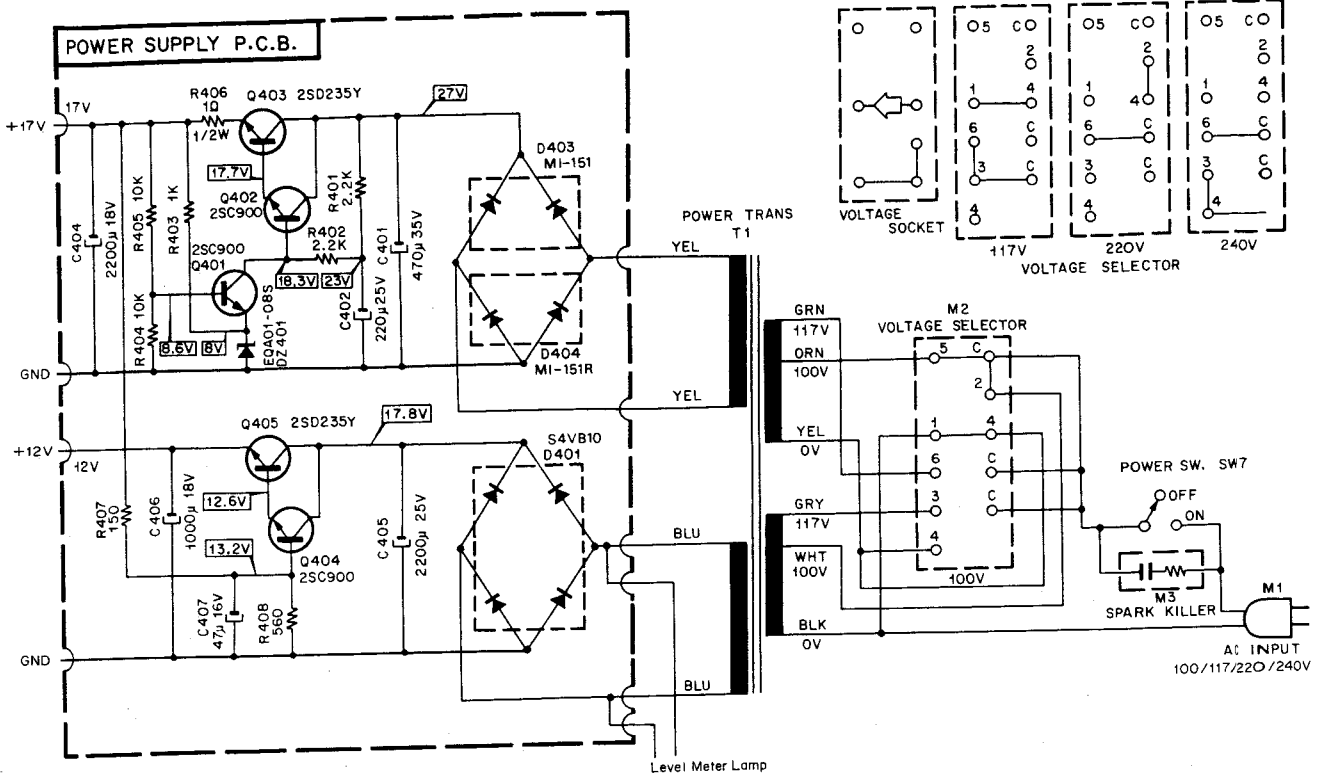

Fig. 2.2.16 Power Supply Circuit Diagram

2.3. Mechanism Control Circuits

The Mechanism Control Circuits consist of a logic control, shut-off control, azimuth alignment detector, motor governor, etc. Refer to Fig. 12.2 "Mechanism Control Block Diagram".

2.3.1. Logic Control

(1) General

The commands from touch control switches are communicated to the logic control circuits. Logic outputs are connected to the delay circuits and drivers for control of mechanisms.

Logic circuits consist of TTL ICs, the details of which are as follows:

a. Main characteristics of TTL IC

Supply voltage	5 V
Logical L output voltage	less than 0.5 V
Logical H output voltage	3 V to 4 V
Noise immunity	1 V
Temperature range	0° to 70°C

b. Gate Logic

The inputs are IN1, IN2 and IN3, and the output from the gate is shown below:

The output will be an L only if IN1 and IN2 and IN3 are all H's, and the output will be an H if IN1 is an L or IN2 is an L or IN3 is an L.

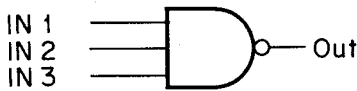

$$\text{Out} = \overline{\text{IN1} \cdot \text{IN2} \cdot \text{IN3}}$$

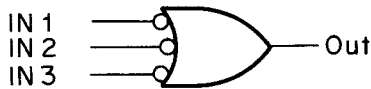

$$\text{Out} = \overline{\text{IN1}} + \overline{\text{IN2}} + \overline{\text{IN3}}$$

$$\text{Out} = \overline{\text{IN1} \cdot \text{IN2} \cdot \text{IN3}} = \overline{\text{IN1}} + \overline{\text{IN2}} + \overline{\text{IN3}}$$

Fig. 2.3.1

Truth Table 1

IN1	IN2	IN3	Out
L	L	L	H
H	L	L	H
L	H	L	H
H	H	L	H
L	L	H	H
H	L	H	H
L	H	H	H
H	H	H	L

The construction of the foregoing 2 Logic Symbols is identical and intended to show the use of either AND or OR.

c. Gated Flip-Flop

The two NAND gates can be used to form flip-flop.

The inputs operate as follows:

When both S and R are H's, the flip-flop will remain in its present state, i.e., will not change states.

If however, the R input goes to an L, the NAND gate connected to R will have an H output regardless of the other feedback input to the NAND gate, and this will force the flip-flop to the L state (provided the S input is kept H). Similar reasoning shows that making the S input an L will cause the NAND gate at the S input to have an L output, forcing the flip-flop to the H state (again provided the R input is kept H).

If both inputs R and S are made L's, the next state will depend on which input is returned to H first, and if both are returned to H simultaneously, the resulting state of the flip-flop will be indeterminate. As a result, this is a "forbidden" or "restricted" input combination.

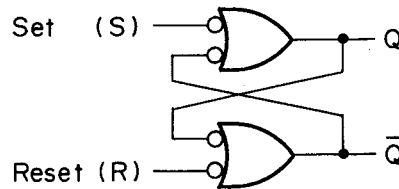

Fig. 2.3.2

Truth Table 2

Set	Reset	Q	Q̄	Remarks
L	L	H	H	*: To maintain the previous state, but indefinite if both of the previous inputs S and R are made L's.
H	L	L	H	
L	H	H	L	
H	H	*	*	

In the actual use, the activation speed of the Flip-Flop is managed to be delayed in order to prevent erroneous movements caused by noise with details being as follows:

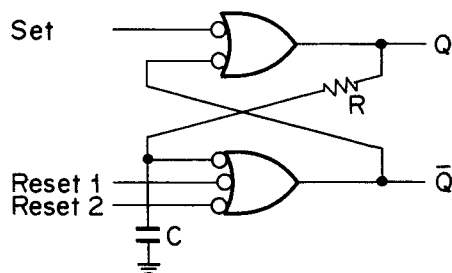

Fig. 2.3.3

d. Schematics and Block Diagrams

SN7400N (Quadruple 2-input positive NAND GATE)

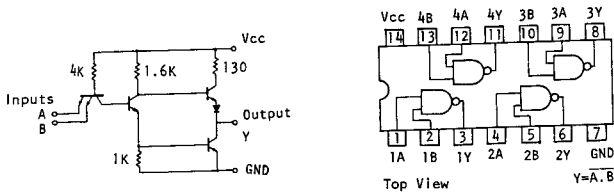

Fig. 2.3.4 SN7400N

SN7410N (Triple 3-input positive NAND GATE)

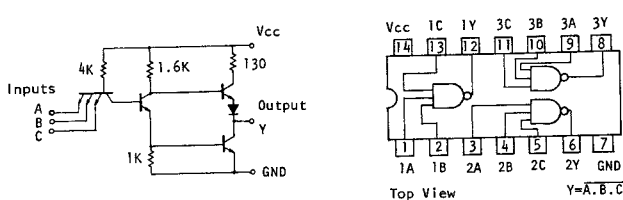

Fig. 2.3.5 SN7410N

SN7420N (Dual 4-input positive NAND GATE)

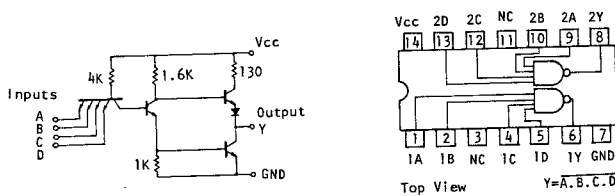

Fig. 2.3.6 SN7420N

e. Compatible ICs

The following ICs belong to the same group which can be replaced:

L601, L603, L605	: N7400A, SN7400N, M53200P, HD2503, TD3400P
L602, L606	: N7410A, SN7410N, M53210P, HD2507, TD3410P
L604	: N7420A, SN7420N, M53220P, HD2504, TD3420P

(2) Logic Control

A foolproof operation will be done by logic control. For example, when command the playback mode while fast winding or command fast-forward mode while re-winding, it is guaranteed that no abnormal tape tension will happen by passing through the stop mode. This is also guaranteed even when the buttons are touched on simultaneously.

a. Logic Signal

How to read the signals is referred to the following:

The signal H shows the condition that the signal is

executing, and in case there is a $\bar{\quad}$ on the signal, signal L shows the condition that the signal is executing.

\bar{K} stop (control stop button signal)

\bar{K} stop becomes L when the stop button is touched on, and \bar{K} stop is H while button is open.

\overline{PLY} (Play flip-flop \bar{O} output signal)

\overline{PLY} = L shows at play mode, and H shows out of play mode.

PLY (Play flip-flop Q output signal)

PLY = H shows at play mode, and L shows out of play mode.

\overline{HB} = $\overline{PLY} \cdot \overline{Fst DL} \cdot \overline{PAU}$

\overline{HB} = L drives the head base solenoid.

\overline{HB} signal becomes L when $\overline{PLY} = H$ AND $\overline{Fst DL} = L$ AND $\overline{PAU} = L$.

b. Logic Operating Status

Refer to Fig. 2.3.7 (Logic Status). Each stage of logic status is shown for the sequential control button command.

c. + 5 V Power Supply for ICs

+ 5 V DC power supply is made by regulated + 12 V DC from the Power Supply Unit. The transistor Q610 acts as a regulator, being controlled by zener diode ZD601.

d. Initial Reset

At power switch ON, + 12 V DC comes up gradually then the transistors Q609 and Q608 turn to ON for only a certain period while Q609 base voltage is low with respect to the emitter (+ 5 V).

And \bar{K} stop = L pulse is generated.

At power switch OFF, + 12 V discharges gradually, and \bar{K} stop = L pulse is also generated. \bar{K} stop = L pulse clears each flip-flop and keeps at the initial condition, stop mode.

e. Stop Mode

The stop button when touched on and the cassette well when opened make \bar{K} stop=L and resets each of the flip-flops. \bar{K} stop=L pulse is generated when shut-off is detected and when + 12 V is lowered about by 70%.

f. Play Mode (Playback or Record Mode)

The play button when touched on makes \bar{K} play=L and sets the PLY Flip-Flop, (\overline{PLY} =H, L605-8), and head base solenoid will be activated.

g. Record Mode

REC Flip-Flop (REC, L603-6) will be set to H when record button (\bar{K} rec=L) and play button (\bar{K} play=L) are touched on simultaneously, or record button and pause button (\bar{K} pau=L) are touched on and then play button is touched on.

REC=H commands the bias oscillation of Amp.

Note: To close record protect switch is required.

h. Pause Mode

While recording or playback, the pause button when touched on sets the PAU Flip-Flop, PAU=H (L603-8). Then \overline{HB} signal turns to H and head base solenoid will be released.

i. Fast Wind Mode

The rewind ($\overline{K_{rew}}=L$) or fast forward button ($\overline{K_{ff}}=L$) when touched on sets the FST Flip-Flop. While the \overline{REW} / \overline{FF} Flip-Flop is set to $\overline{REW}=L$ (L606-12) or $\overline{FF}=L$ (L606-8), \overline{REW} or $\overline{FF}=L$ will drive the REW or FF Relay, and Reel Motor will turn backward or forward.

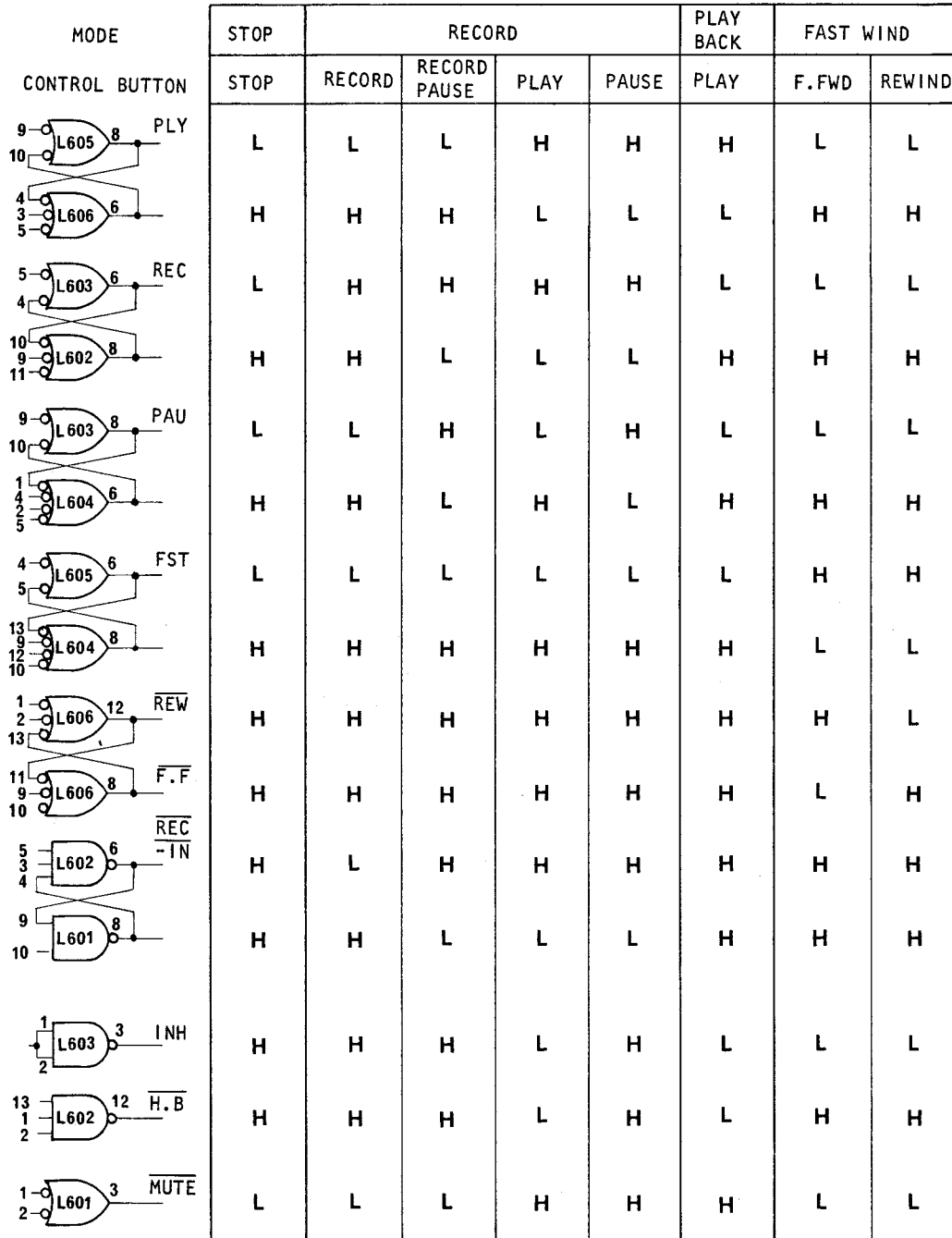

Fig. 2.3.7 Logic Status

j. Mute Signal

$\overline{HB}=L$ or $\overline{PAU}=L$ makes Mute signal (L601-3) to H and will release the mute of the Amp.
(The mute of record Amp. is released only at record mode, and playback Amp. are released at record and playback modes).

k. Memory Stop

While memory switch is ON and rewinding, stops tape travel when the tape counter comes to "999".
At counter "999", L606-12 ($\overline{REW}=L$) and capacitor C624 are connected, therefore the differentiated pulse is generated at L604-10.
This pulse resets Fst Flip-Flop turning to $\overline{REW}=H$, and stops rewinding.

(3) Drivers and other Signals

a. Touch Switch

This is of electronic-control switch and will become ON when you place a finger on the white metal strips running along the Control Switch Board. In Fig. 2.3.8, when you touch the metal strip A, base current will be applied to transistor Q1 through R1 and R (your finger), and thus Q1 will be activated, thereby collector current is fed to the Q7 base from Q1 and Q7 will therefore become saturated.

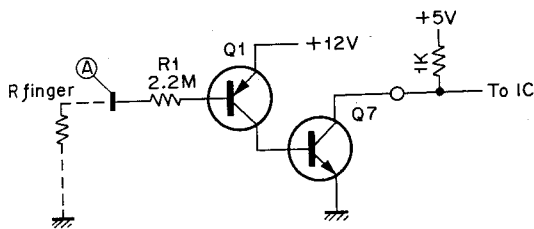

Fig. 2.3.8 Touch Switch Circuit

b. Lamps

- Play Lamp — Lights on when head base solenoid is set to ON.
- Record and Pause Lamps — Light on in the memory state of REC and PAU Flip-Flop respectively.
- Rewind Lamp — Illuminates at Rew Relay ON.
- F.Fwd Lamp — Illuminates at F.Fwd Relay ON.
- Stop Lamp — Illuminates in the state other than the above.

c. Head Base solenoid

When the PLAY Flip-Flop is set, the head base solenoid will be driven by the $\overline{HB}(L602-12)=L$.
However while in pause mode, the $\overline{PAU}(L602-2)=L$ will inhibit the $\overline{HB}=L$ signal.
The $\overline{Fst DL}(L602-1)$ signal will serve to drive the head base solenoid after a certain period for stopping Fast Wind, when the play button is set to ON during Fast Wind.

In this regard, the resistor (R680 15 ohms) connected in series to the solenoid will be shorted by the Q627 and Q626 on the base switch P.C.B. ass'y before the drive of head base and limit switch ON.

d. Reel Motor

The FF Relay will drive while the $\overline{REW} / \overline{FF}$ Flip-Flop is $\overline{FF}=L$ and REW Relay being $\overline{REW}=L$.
One side of the Reel Motor is connected to the REW Relay and the other to the FF Relay, and the Relay is connected while OFF the ground and while ON + 12 V.
Rewind = REW Relay ON · FF Relay OFF
F. Fwd = REW Relay OFF · FF Relay ON
Stop = REW Relay OFF · FF Relay OFF

e. Brake solenoid

Brake solenoid driver is connected in parallel to the Reel Motor.
Brake Solenoid is released when reel motor runs, and vice versa.

f. Rec Signal

Rec signal connected to the Amp. controls ON/OFF of the bias oscillation. \overline{Rec} signal H conducts the bias oscillation.
The Rec and \overline{Rec} signals connected to the Pitch Control Volume serve in selecting the speed of the capstan motor for recording and playback.

g. Shut-off Detector Inhibition Signal

Prevents the shut-off signal from entering the Logic while the take-up reel is not turning.
Inhibition signal will be released by $\overline{HB} = L$ or $\overline{FST} = L$, namely while tape is travelling or in Fast Winding mode.
After $\overline{HB} = L$ or $\overline{FST} = L$ is commanded, it is considered to be an enough delay time to release shut-off inhibition signal for assurance of the stable start of the take-up reel movement.

2.3.2. Shut-off Sensor and Detector

Refer to Figs. 2.3.9 and 2.3.10.

Shut-off sensor consists of LED (Light Emitting Diode), photo transistor and slitted disc plate which is rotated by take-up reel.

Through turning disc plate, intermittent LED's lights are generated, while photo transistor is receiving these lights and output sensor signals. A shut-off signal which clears the Logic Flip-Flop will be generated when stop of sensor signals is detected by shut-off detector at a tape end.

- (1) The capacitor C611 (0.12 μ F) is charged through resistor R622 (1.8 M ohms). While sensor output signals are differentiated by C610 and differentiated positive pulses set a transistor Q605 to ON, then Q605 will discharge quickly.
- (2) At a tape end, sensor signal will not generate and C611 will be kept charged. When the voltage of C611 exceeds the Q606 emitter voltage (about 2.3 V), Q606 and Q607 turn to ON, therefore Q608 turns to ON and shut-off signal ($\overline{K\ stop=L}$) will be generated.

- (3) Shut-off signal resets PLY and Fst Flip-Flops, therefore INHIBIT signal (INH, L603-3) will be set to H. A base current of Q605 flows through INHIBIT signal H and Q605 turns to ON and discharges the C611. Therefore Q605, Q606 and Q608 turn to OFF and shut-off signal will be released.

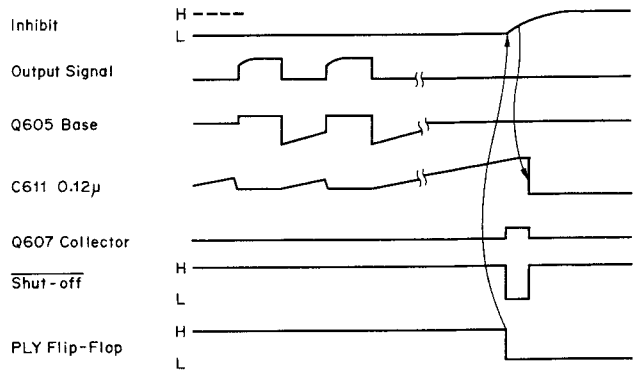

Fig. 2.3.10 Shut-off Timing Chart

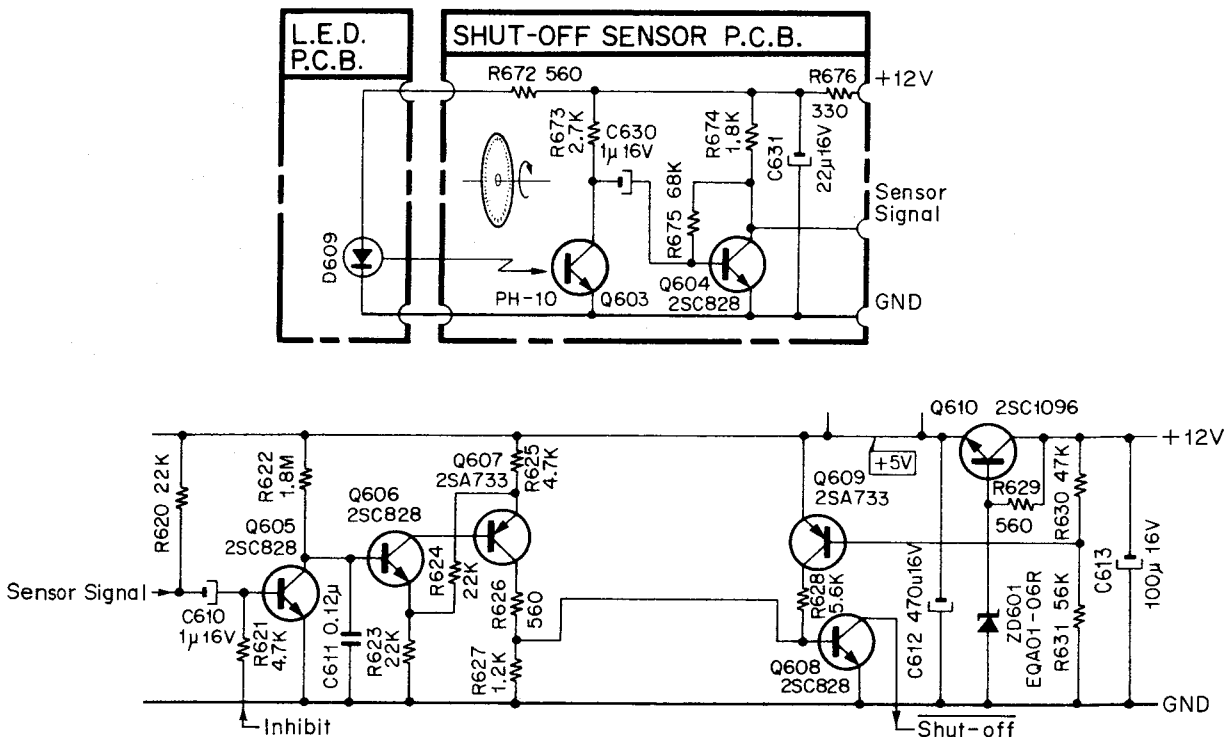

Fig. 2.3.9 Shut-off Sensor and Detector Circuit Diagram

2.3.3. Azimuth Alignment Detector

Refer to Figs. 2.3.13 and 2.3.14.

Prior to recording, it is required that the azimuth alignment be conducted for both sides A/B of a cassette tape to keep the optimum performance, with details being as follows:

Each cassette housing has a distortion for the molded pin locating between record and playback heads, therefore when tape is travelling through the molded pin the travelling of tape is slightly changed by each cassette housing.

And adjustment aims at an accurate azimuth alignment of the record and playback heads through a travelling tape. Adjustment shall be conducted by turning the azimuth alignment screw while record mode and the adjustment panel test tone switch is ON.

When the recorded 400 Hz tape is played back, the difference of the phase between right and left channels indicates the difference of playback and record head azimuth.

Therefore when the difference of the phase equals to zero, playback and record head azimuth is aligned then both of the alignment beacon flicker alternately.

- (1) Left and right channel playback signals which are communicated to the operational amplifier terminals 5 and 9 will be amplified to the rectangular waves.
- (2) These rectangular waves are converted to the TTL IC voltage level through transistors Q601 and Q602, and communicated to the L607 TTL IC terminals "T" and "D".
- (3) The outputs of L607 begin to repeat ON and OFF and conduct to flicker LEDs alternately when same phase signals are conducted to "T" and "D" terminals.
- (4) Function of L607:
At transition of "T" terminal from L to H, "D" terminal H conducts output Q to H and \bar{Q} to L and also "D" terminal L conducts output Q to L and \bar{Q} to H.
- (5) SN7474N (Dual D-Type Edge-triggered Flip-Flop)

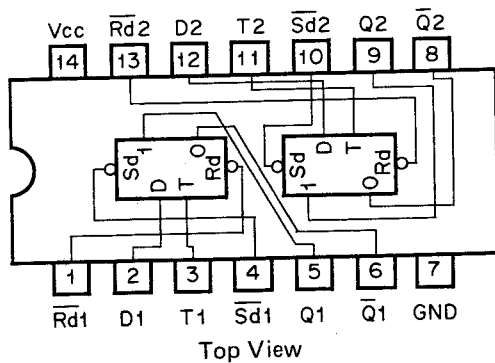

Fig. 2.3.11 SN7474N

tn	tn+1	
Input D	Output Q	Output \bar{Q}
L	L	H
H	H	L

tn: Bit time before clock pulse.
tn+1: Bit time after clock pulse.

Compatible ICs

L607: N7474A, SN7474N, M53274P, HD2510, TD3474P

(6) RC4709 (Dual Operational Amplifier)

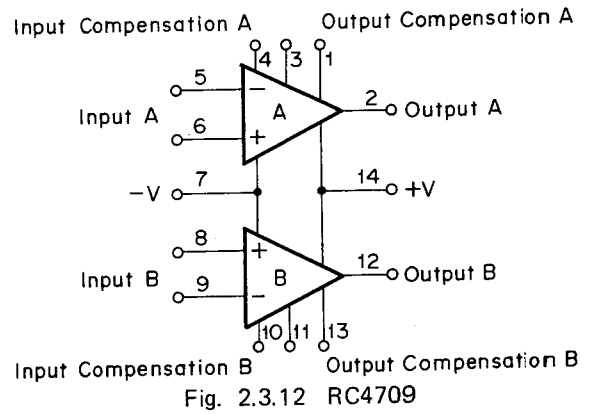

Fig. 2.3.12 RC4709

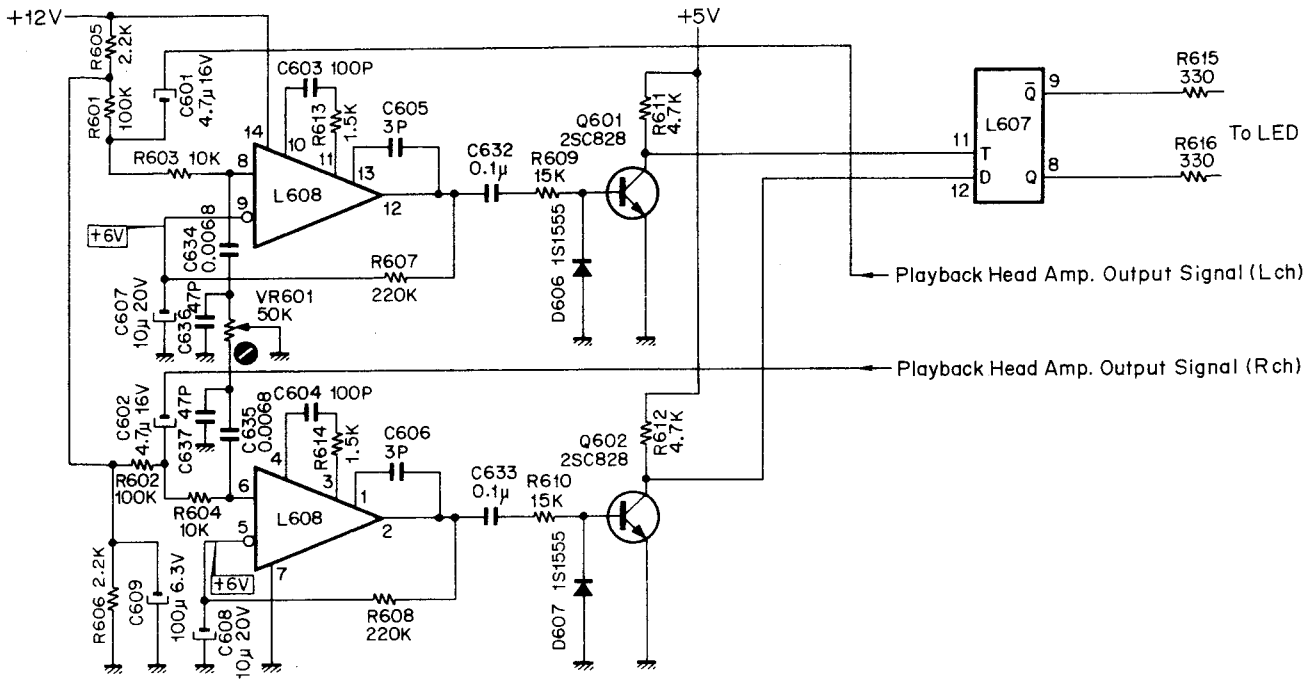
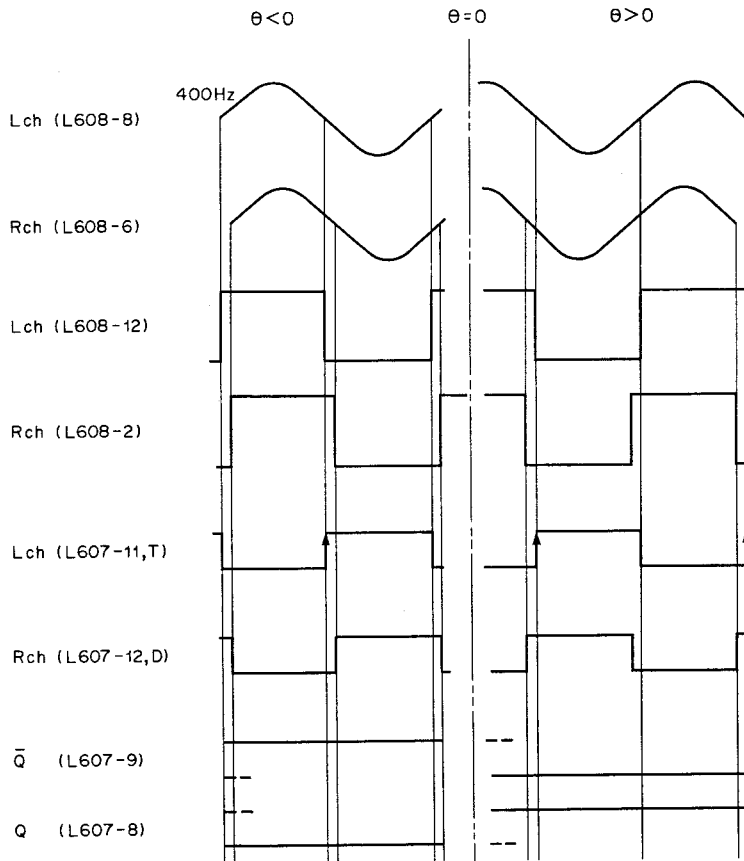

Fig. 2.3.13 Azimuth Alignment Detector Circuit Diagram



θ : difference of phase between L ch and R ch Playback Head Amp. Output signals.

Fig. 2.3.14 Azimuth Alignment Detector Timing Chart

2.3.4. Capstan Motor Governor

Refer to Figs. 2.3.16 and 2.3.17.

Capstan motor governor connects to the Motor Assembly consisting of motor and sensor. Sensor consists of LED (Light Emitting Diode), photo transistor and slitted disc plate which is turned by motor.

When disc plate is turned, intermittent LED's lights are generated, while photo transistor receives these lights and outputs signals to the motor governor.

Sensor generates proportional frequency signals according to the motor speed. Motor governor controls the motor current in order to keep the constant sensor output signal i.e. constant motor speed.

- (1) Sensor output signals are amplified to the rectangular waves by IC 501 1/2.
- (2) Through transistor Q501 differentiated pulses are generated by capacitor C506 (150 pF).
- (3) C507 (330 pF) (IC501 2/2-6) is charged through resistor R511 (150 k ohms) gradually. While the above operation, the differentiated positive pulse commands to discharge C507 quickly. Therefore charge and discharge are repeated according to the periodic time of sensor signal.
- (4) The voltage of IC 501 2/2-5 is fixed through pitch control volume, and when IC 501 2/2-6 is higher with respect to the 5 pin voltage, IC 501 2/2-7 output falls to ground and turns Q502 to ON.
- (5) C509 (1 μF) will charge through Q503 and discharge through R516 (10 k ohms). A base current of Q504 flows through C509, then Q504, Q505 and Q506 amplifiers act to drive a motor.
- (6) Q503 turn ON time gets short when periodic time of sensor output signal is shorted, and the voltage of C509 decreases, then motor speed will also decrease. When periodic sensor output signal becomes fast, the voltage of C509 and motor speed will increase. Motor speed is therefore kept constant.

(7) 4558 (Dual Operational Amplifier)

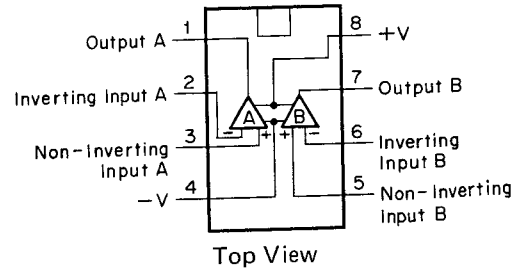

Fig. 2.3.15 4558

Sensor Signal (Q507 Collector) About 2.8kHz AC Signal
4 to 7 Vdc Bias

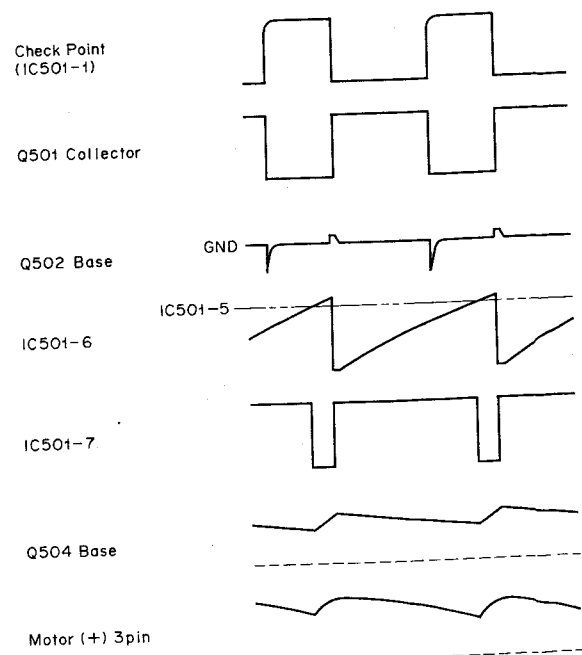

Fig. 2.3.17 Capstan Motor Governor Timing Chart

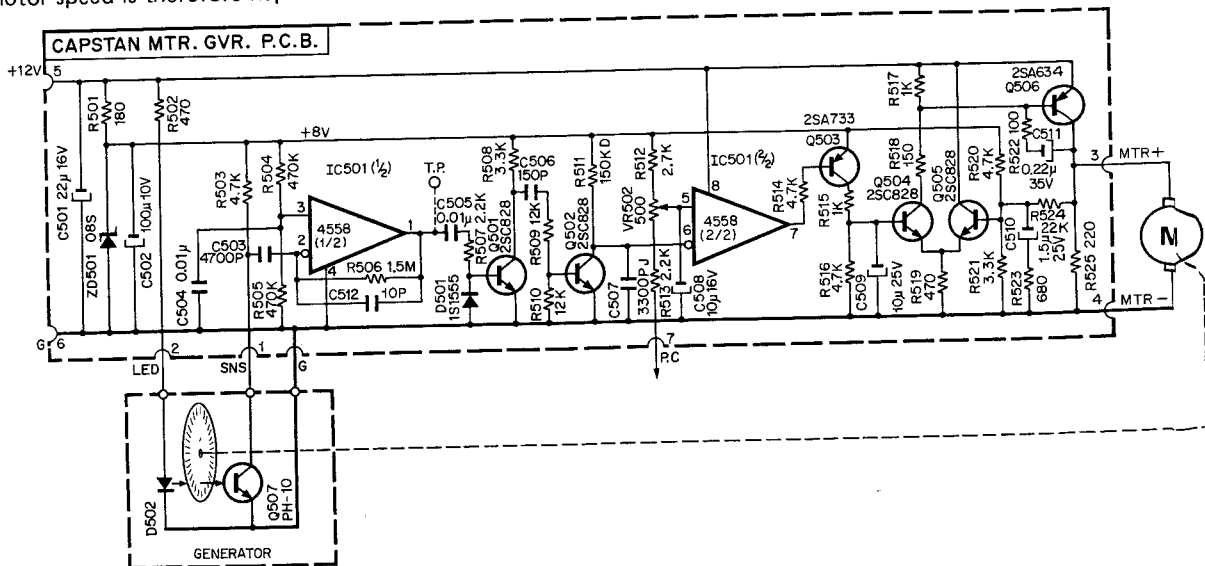

Fig. 2.3.16 Capstan Motor Governor Circuit Diagram

2.3.5. Reel Motor Governor

Refer to Fig. 2.3.18.

While in Play mode, motor speed is detected by bridging, observing the counter electro motive force of the motor. A bridging consists of a motor to be one side, and the electric potential between A and B (shown in Fig. 2.3.18) should theoretically become proportional to the motor speed if the condition meets the formula;

$$\frac{R}{R2} = \frac{R3//R5}{R4}$$

In the circuit, a constant motor speed can be secured because the potential between A and B is servo-controlled by Q3 to become constant.

While in FF and REW modes, + 12 V is fed directly to the Reel Motor, and the motor will rotate either clockwise or counterclockwise depending upon the given polarity.

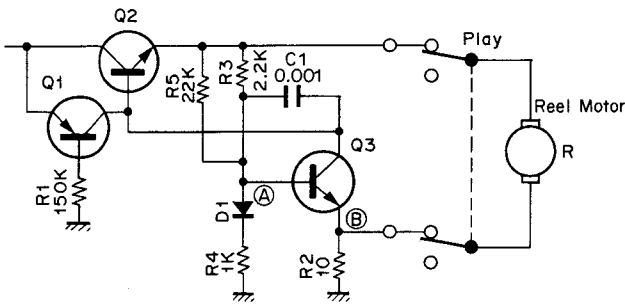

Fig. 2.3.18 Reel Motor Governor Circuit Diagram

2.3.6. Head Base Solenoid Driver

Refer to Fig. 2.3.19.

SW1 is closed while in Stop mode. If the PLAY button is effected, Q614 of the Logic Control Circuit will become ON. Accordingly a base current of Q1 is fed through R1 and SW1, then Q1 and Q2 become ON.

With Q2 ON, R680 (15 ohms) will be shorted and therefore + 12 V will be applied to solenoid.

When the solenoid acted to pull the Head Base inwardly, SW1 will become open. At this time base current will be fed to C1 from Q1 for a while, but Q1, Q2 will become OFF, as a result of which R680 (15 ohms) is connected in series to the solenoid and + 12 V will be supplied thereto. In other words, + 12 V is given to the solenoid while the Head Base is being mechanically pulled inwardly, and to maintain that state of the Head Base, a resistor is added in series so that the power loss can be reduced.

2.3.7. Brake Solenoid Driver

Refer to Fig. 2.3.20.

The brake solenoid releases brake while in REW or FF mode (brake will be mechanically released while in Play mode as the head base itself moves outwardly).

When the relay (RL601/RL602 of the Logic Control Circuit) is turned ON either while REW or FF mode, base current will be applied to Q1 from + 12 V through R1 or R2, as a result of which Q1 becomes ON and Q2 becomes OFF. Capacitor C1 starts charging through R4, and Q3 and Q4 will become ON, when the voltage thus being charged exceeds the total of base-emitter voltage of Q3 and Q4, thereby driving the brake solenoid.

As above, there is a certain time delay until the brake solenoid circuit while in REW or FF mode releases brake.

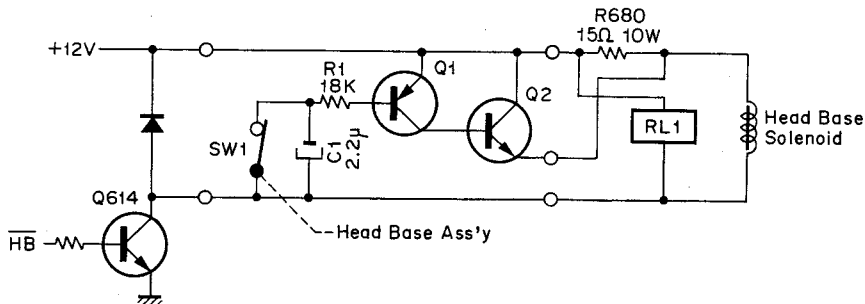

Fig. 2.3.19 Head Base Solenoid Circuit Diagram

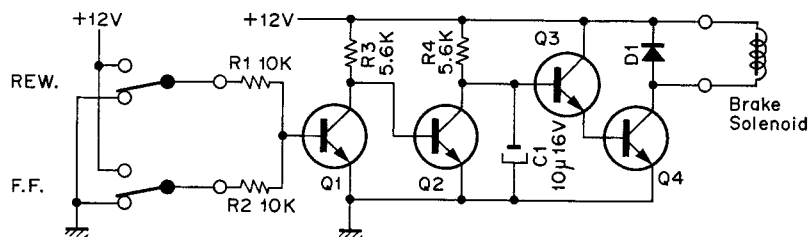

Fig. 2.3.20 Brake Solenoid Circuit Diagram

3. REMOVAL PROCEDURES

3.1. Cassette Lid Ass'y and Adjust Lid Ass'y

Refer to Fig. 10.1.

- (1) Depress the Eject Button and Cal. Button.
- (2) Remove F13 (Cassette Lid Ass'y).
- (3) Remove F14 (Adjust Lid Ass'y).

3.2. Cabinet Ass'y

Refer to Fig. 10.1.

- (1) Remove F01 and F02 (screws and washers) then remove F03 and F04 (Voltage Selector Cover).
- (2) Remove F05 and F06 (screws and washers) then separate F07 (Cabinet Ass'y).

3.3. Front Panel Ass'y

Refer to Fig. 10.1.

- (1) Perform above items 1 and 2 and remove Cassette Lid Ass'y, Adjust Lid Ass'y and Cabinet Ass'y.
- (2) Pull out F08 and F09 (volume knobs).
- (3) Remove F10 (screws) then F11 (Front Sash).
- (4) Remove F12 (Control Panel Ass'y).
- (5) Remove F15 and F16 (screws and washers) then F17 (Front Panel Ass'y).

3.4. Touch Switch Ass'y

Refer to Fig. 10.4.

- (1) Perform above items 1 – 3.
- (2) Remove F97 and F98 (screws and washers) then F99 (Touch Switch Ass'y).

3.5. Head Mount Base E Ass'y

Refer to Fig. 10.5.1.

- (1) Pull out F18 (Pitch Control Knob).
- (2) Remove F19 and F20 (screws and washers) then F21 (Mount Base Cover).
- (3) Remove F22 (Test Tone Himelon).
- (4) Remove F23 (screw) then Mount Base Cover Ass'y.
- (5) Remove F24 (Pressure Roller Arm Springs).
- (6) Remove F25 and F26 (screws) then disassemble F27 (Head Mount Base Ass'y).

3.6. Pressure Roller Ass'y

Refer to Fig. 10.7.

- (1) Perform above item 5.
- (2) Remove F28 (E-ring).
- (3) Disassemble F29 (Pressure Arm Shaft Spring) and F30 (Pressure Arm Collar B), then remove F31 (Pressure Roller Ass'y).

3.7. Head Base Solenoid Ass'y

Refer to Fig. 10.5.3.

- (1) Perform above items 1 – 3.
- (2) Remove F32 and F33 (screws and washers).
- (3) Remove F34 (E-ring) then F35 (Head Base Damper Ass'y).

3.8. Flywheel Ass'y and Capstan Belt

Refer to Fig. 10.5.3.

- (1) Perform above items 1 – 3.
- (2) Unfasten F36 (screws) then remove F37 (Flywheel Holder).
- (3) Remove F38 (Capstan Belt).
- (4) Remove F39 (Flywheel Ass'y B) and then F40 (Flywheel Ass'y A).

3.9. Brake Solenoid Ass'y

Refer to Fig. 10.5.3.

- (1) Perform above items 1 – 3.
- (2) Perform above item 8.
- (3) Remove F41 (E-ring).
- (4) Unfasten F42 (screws) then disassemble F44 (Brake Solenoid Ass'y) by removing F43 (Brake Solenoid P.C.B. Ass'y).

3.10. Eject Damper Bracket Ass'y

Refer to Fig. 10.5.4.

- (1) Perform above items 1 – 3.
- (2) Unfasten F45 and F46 (screws) then remove F47 (Eject Damper Ass'y).

3.11. Ball Drive Mechanism Ass'y

Refer to Fig. 10.5.3.

- (1) Perform above items 1 – 3.
- (2) Perform above item 8.
- (3) Remove F48 (Center Drive Belt).
- (4) Remove F49 and F50 (screws and washers) then disassemble F51 (Ball Drive Mechanism Ass'y).

3.12. Shut-off Ass'y

Refer to Fig. 10.5.1.

- (1) Perform above items 1 – 3.
- (2) Unfasten F52 (screws).
- (3) Disassemble F53 (Shut-off Belt) then remove F54 (Shut-off Ass'y).

3.13. Reel Motor Ass'y

Refer to Fig. 10.5.4.

- (1) Perform above items 1 – 3.
- (2) Unfasten F55 (screws) then remove F56 (Reel Motor Ass'y).

3.14. Rear Panel Ass'y and Transformer

Refer to Fig. 10.2.

- (1) Perform above items 1 – 3.
- (2) Remove F57 and 58 (screws and washers) then F59 (Rear Panel Ass'y).
- (3) Unfasten F60 (screws) then remove F61 (P.C.B. Holder Ass'y).
- (4) Remove F62 and F63 (screws and Bolt Receptacle Plate) then F64 (DC Power Supply Ass'y).
- (5) Remove F65 and F66 then F67 (Trans. Shield Plate).
- (6) Remove F68 (screws) then F69 (Transformer).

3.15. Reel Motor Governor Ass'y

Refer to Fig. 10.5.4.

- (1) Perform above items 1 – 3.
- (2) Remove F70 (screws) then F71 (Reel Motor Governor Ass'y).

3.16. Base Switch Ass'y

Refer to Fig. 10.5.4.

- (1) Perform above items 1 – 3.
- (2) Remove F72 (screw) then F73 (Base Switch Ass'y).

3.17. Capstan Motor Ass'y

Refer to Fig. 10.5.4.

- (1) Perform above items 1 – 3.
- (2) Remove F74 (screws) then F75 (Capstan Motor Ass'y).
Remove F76 (Motor Cap Ass'y).

3.18. Logic Control P.C.B. Ass'y

Refer to Fig. 10.5.4.

- (1) Perform above items 1 and 2.
- (2) Remove F77 (screws) and F78 (connectors) then F79 (Logic Control P.C.B. Ass'y).

3.19. Front Control P.C.B. Ass'y and Switch P.C.B. Ass'y

Refer to Figs. 10.1 and 10.2.

- (1) Perform above items 1 – 3.
- (2) Referring to Fig. 10.1, remove F80 (screws) and then F81 (Panel Stopper).
- (3) Referring to Fig. 10.2, unfasten F82 and F83 (screws) then remove F84 (Front Control P.C.B. Ass'y with Control Chassis) and F85 (Switch P.C.B. Ass'y).

3.20. PB Head Amp. P.C.B. Ass'y, PB Dolby NR P.C.B. Ass'y and Record Dolby NR P.C.B. Ass'y

Refer to Fig. 10.2.

- (1) Perform above items 1 – 3.
- (2) Unfasten F60 (screws) then remove F61 (P.C.B. Holder Ass'y).
- (3) Remove F86, F87 and F88 (P.C.B. Assemblies).

3.21. Main P.C.B. Ass'y

Refer to Fig. 10.2

- (1) Perform above items 1 – 3
- (2) Unfasten F60 (screws) then remove F61 (P.C.B. Holder Ass'y) and F86, F87, F88 (P.C.B. Assemblies).
- (3) Remove F89 and F90 (screws and washers) then F91 (Main P.C.B. Ass'y). Each connector should be pulled out.

3.22. DC Power Supply P.C.B. Ass'y

Refer to Fig. 10.2.

- (1) Perform above items 1 – 3.
- (2) Remove F62 (screws) and F63 (Bolt Receptacle Plate) then F64 (DC Power Supply P.C.B. Ass'y).

3.23. 400 Hz Osc. Switch P.C.B. Ass'y

Refer to Figs. 10.5.1 and 10.9.

- (1) Perform above item 1.
- (2) Referring to Fig. 10.5.1, pull out F18 (Pitch Control Knob).
- (3) Remove F19 and F20 (screws and washers) then F21 (Mount Base Cover).
- (4) Remove F22 (Test Tone Himelon).
- (5) Referring to Fig. 10.9, remove F92 (screws) and F93 (nuts, washers and collars), then F94 (Shield Plate).
- (6) Remove F95 (screws and washers) then F96 (Osc. Switch P.C.B. Ass'y).

4. CHECK-OUT PROCEDURES

4.1. Check-Out Procedures for Inspection

4.1.1. Turn on the power switch.

- (1) Check to insure whether meter lamps, tape illumination lamp and stop lamp light, and whether the machine is held in stop mode.

4.1.2. Push the eject button.

- (1) No control button operates, once cassette lid is opened.

4.1.3. Load a reference tape then touch on the play button

- (1) Play lamp turns to on and tape runs at a speed of 1-7/8 ips.
- (2) Auto shut-off function operates only a tape end so that machine is set to stop mode.
- (3) While tape is travelling check to insure whether stop, fast forward and rewind buttons operate.

When stop button is touched on, machine stops. When fast forward button is touched on, fast forward lamp turns to on and tape travelling is changed to fast forward winding mode. When rewind button is touched on, rewind lamp turns to on and tape travelling is changed to rewind mode.

4.1.4. Touch on the fast forward button.

- (1) Fast forward lamp turns to on and tape runs at a speed of about 61 ips.
- (2) Auto shut-off function operates only at an end of tape so that machine is set to stop mode.
- (3) When play, rewind, or stop button is touched on, fast forward mode is changed to playback mode, rewind mode, or stop mode according to each button.

4.1.5. Touch on the rewind button with memory switch off.

- (1) Rewind lamp turns to on and tape runs at a speed of about 61 ips.
- (2) Auto shut-off function operates only at an end of tape so that machine is set to stop mode.
- (3) When play, fast forward, or stop button is touched on, rewind mode is changed to playback mode, fast forward mode, or stop mode according to each button.
- (4) For check of memory stop, turn on the memory switch and reset the tape counter to "000". After winding the tape, set to the rewind mode and check to insure that the rewind mode changes to stop mode at counter "999".

4.1.6. Touch on the pause button.

- (1) Pause button operates while playback and recording so that pause mode is set, and tape travelling is stopped by releasing head base solenoid drive. When playback or recording re-starts, mute function operates for about 1 second.
- (2) When pause button is touched on at stop mode, pause lamp turns on and stop lamp turns off. When pause button is touched on at fast forward or rewind mode, pause lamp illuminates only while button is touched.

4.1.7. Touch on the record button.

- (1) Except for break-out legs of the loaded cassette and without any loaded cassette, record mode operates only when record button is touched on at stop mode.
- (2) Touch on the pause button while record mode is functioning. Record/pause mode will operate.
- (3) Touch on the play button while record mode is functioning. Recording mode will operate.

4.1.8. Touch on the stop button.

- (1) Check to insure whether playback, recording, fast forward and rewind modes are set to stop mode.

4.1.9. Monitor switch ON/OFF.

- (1) Check to insure whether monitor outputs can be selected from source to tape monitor by setting monitor switch on and off.

4.1.10. Dolby NR switch IN/OUT.

- (1) When playback, hiss noise will reduce at switch IN.

4.1.11. Tape selector switch EX/SX and Eq. selector switch 120 μ s/70 μ s.

- (1) While playback, check to insure whether tape selector switch and Eq. selector switch are operating accurately.

4.1.12. Test tone switch ON/OFF.

- (1) Switch on the test tone switch and set the monitor switch to source, and check to insure that 400 Hz test tone is generating by measuring level meters or headphone, etc.
- (2) Check to insure whether alignment beacon is illuminating at either one channel or both channels.

4.1.13. Listening test.

- (1) Connect music source to the input jacks and amplifier and speakers to the output jacks, and test the performance of playback and record/playback. Prior to recording, align the record head azimuth by azimuth alignment operation.
- (2) Check the wow/flutter, distortion, signal to noise ratio, erasure, etc.

4.2. Check Methods

4.2.1. Check on playback functions:

- (1) Check to insure whether the capstan, heads or pressure roller is free from dirt or dust.
- (2) Check on tape travel.
- (3) Load a 400 Hz tape.
- (4) Set the machine in play mode.
- (5) Check the output of PB head amp. (both channels).
- (6) Check the output of PB Dolby NR (both channels).
- (7) Check the output of Line amp. (both channels).
- (8) Check the output jack (both channels).
- (9) Check headphone jack.

4.2.2. Check while recording:

Set each of input level controls to maximum, apply the rated input signal level to input jack and then check indications of the meters.

- (1) Check the Mic and DIN amp.
- (2) Check MPX functions.
- (3) Check Record Dolby NR.
- (4) Check Record Eq. amp.
- (5) Check the bias oscillator circuit.
- (6) Check record head.
- (7) Check erase head.
- (8) Check monitor switch.

4.2.3. Check on Mechanisms:

- (1) Check the track positions of record head and playback head with Track Viewer (DA09012A).
- (2) Check to insure whether the capstan motor rotates when the machine is set to On.
- (3) Touch on the play button, and check to insure whether the head base solenoid activates and whether the take-up reel rotates.
- (4) While in the (3) mode as above, check to insure whether auto shut-off returns the head base and the stop lamp illuminates when take-up reel is stopped by hand.
- (5) When the fast forward button is touched on, check to insure whether the FF lamp illuminates and whether the fast forward mode activates.
- (6) When the take-up reel is stopped by hand while in (5) mode as above, check to insure whether the auto shut-off activates to set the machine in stop mode.
- (7) Touch on the rewind button and check to insure whether the rewind lamp illuminates, rewind mode activates, auto shut-off activates and whether stop lamp lights.
- (8) Load a blank cassette tape.
- (9) Check to insure whether the unit is free from any abnormality while in fast forward and rewind mode.
- (10) Touch on the record and pause buttons simultaneously, and check to insure whether record is paused.

- (11) Touch on the play button while in (10) state, and check to insure whether tape starts travelling and recording commences.
- (12) Touch on the stop button and check to insure whether the machine is set to stop from any of the modes.
- (13) Measure the torque of take-up, fast forward and rewind with torque gauge (DA09013A).
- (14) Check the tape speed and wow/flutter with 3 kHz Speed & Wow/Flutter tape (DA09006A).
- (15) Check the playback head height and tape travel with 1 kHz Track Alignment tape (DA09007A) and Tape Travelling Cassette (DA09011A).

4.2.4. Overall check:

- (1) Check the frequency response (bias adjustment).
- (2) Check distortion.
- (3) Check signal to noise ratio.
- (4) Check channel separation.
- (5) Check crosstalk.
- (6) Check erasure.

4.3. Check Methods When Part(s) is (are) Replaced

When any part/part ass'y of the Nakamichi 700II is replaced with new one, please check to insure the following:

4.3.1. When capstan motor is changed:

- (1) Tape Speed.
- (2) Wow/flutter.
- (3) Check the mechanical noise.

4.3.2. When pressure roller is changed:

- (1) Tape travelling.
- (2) Azimuth/height.
- (3) Tape speed.
- (4) Wow/flutter.

4.3.3. When erase head is replaced:

- (1) Tape travelling.
- (2) Azimuth/height.
- (3) Bias osc. frequency.
- (4) Erasure performance.
- (5) Bias adjustment (overall frequency response).
- (6) Bias leakage.

4.3.4. When record head is replaced:

- (1) Azimuth/height.
- (2) Record track position.
- (3) Bias adjustment (overall frequency response check).
- (4) Adjustment of level at 0 dB with 400 Hz test tone (record calibration).
- (5) Check distortion when 1 kHz is recorded and played back at 0 dB.
- (6) Bias leakage check.
- (7) Phase check (between left and right).

4.3.5. When playback head is replaced:

- (1) Azimuth/height.
- (2) Tape travelling.
- (3) Track position in regard to that of record head.
- (4) Adjustment of playback gain (with test tape at 0 dB).

If unable to adjust to 0 dB, please adjust R123,223 at 3.3 k (P.B. Head Amp. P.C.B.) to:

if strong — make R stronger
if weak — make R weaker

- (5) Frequency response check by playback with test tapes.
- (6) Frequency response check by overall with reference tape.
- (7) Gain check by overall with reference tape.
- (8) Phase check between left and right.

4.3.6. When flywheel ass'y is replaced:

- (1) Tape travelling.
- (2) Azimuth/height.
- (3) Tape speed.
- (4) Wow/flutter.

4.3.7. Ball drive mechanism ass'y is replaced:

- (1) Torque check while F/F, Rew. and Play.
- (2) Mechanical noise check while F/F, Rew. and play, but without a tape.
- (3) Tape speed.
- (4) Wow/flutter.

4.3.8. When meters are replaced:

- (1) Adjustment of meter level.
- (2) Meter check (sticky, etc.).

4.3.9. When reel motor is replaced:

- (1) Torque check while F/F, Rew. and play.
- (2) Check the take-up torque.

4.3.10. When capstan belt is replaced:

- (1) Wow/flutter.
- (2) Tape speed.

4.3.11. When capstan motor governor is replaced:

- (1) Tape speed.
- (2) Wow/flutter.

4.3.12. When tape counter is replaced:

- (1) Tape speed.
- (2) Wow/flutter.
- (3) Memory rewind.
- (4) Counter check (sticky, etc.).

4.3.13. When pneumatic damper is replaced:

- (1) Damper speed check.

4.3.14. When reel motor governor is replaced:

- (1) Tape speed.
- (2) Wow/flutter.
- (3) Torque check while F/F, Rew. and play.

5. MEASUREMENT AND MAINTENANCE INSTRUMENTS

5.1 Measurement Instrument and Connection

Refer to Fig. 5.1, Measurement Connection.

- | | |
|---|---|
| <ul style="list-style-type: none"> (1) Audio Generator (20 Hz – 200 kHz) (2) AC Millivolt Meter (with dB measures) (3) Oscilloscope (DC – 5 MHz) (4) Distortion Meter (5) Speed and Wow/Flutter Meter (6) Frequency Counter (DC – 1 MHz) (7) Ohm Meter (8) DC Volt Meter (0 – 30 V) (9) AC Volt Meter (0 – 400 V) (10) T-100 Audio Analyzer
(Including Distortion, Wow/Flutter, Speed, Oscillator and dB meter) (11) Tape Travelling Cassette (DA09011A) (12) Track Viewer (DA09012A) (13) Torque Gauge (DA09013A) | <ul style="list-style-type: none"> (14) 15 kHz Azimuth Tape (DA09004A) (15) 3 kHz Speed and Wow/Flutter Tape (DA09006A) (16) 1 kHz Track Alignment Tape (DA09007A) (17) 400 Hz Level Tape (DA09005A) (18) 20 kHz PB Frequency Response Tape (DA09001A) (19) 15 kHz PB Frequency Response Tape (DA09002A) (20) 10 kHz PB Frequency Response Tape (DA09003A) (21) Reference EXII Tape (DA09021A) (22) Reference SX Tape (DA09025A) (23) Information Terminals Model M-300
(For positioning of record/playback head.) (24) Liquid for Tape Magnetized Development (MAGNA-SEE, a product of SOUND CRAFT, or equivalent) <p>Note: (10) – (22) are the products of NAKAMICHI RESEARCH INC.</p> |
|---|---|

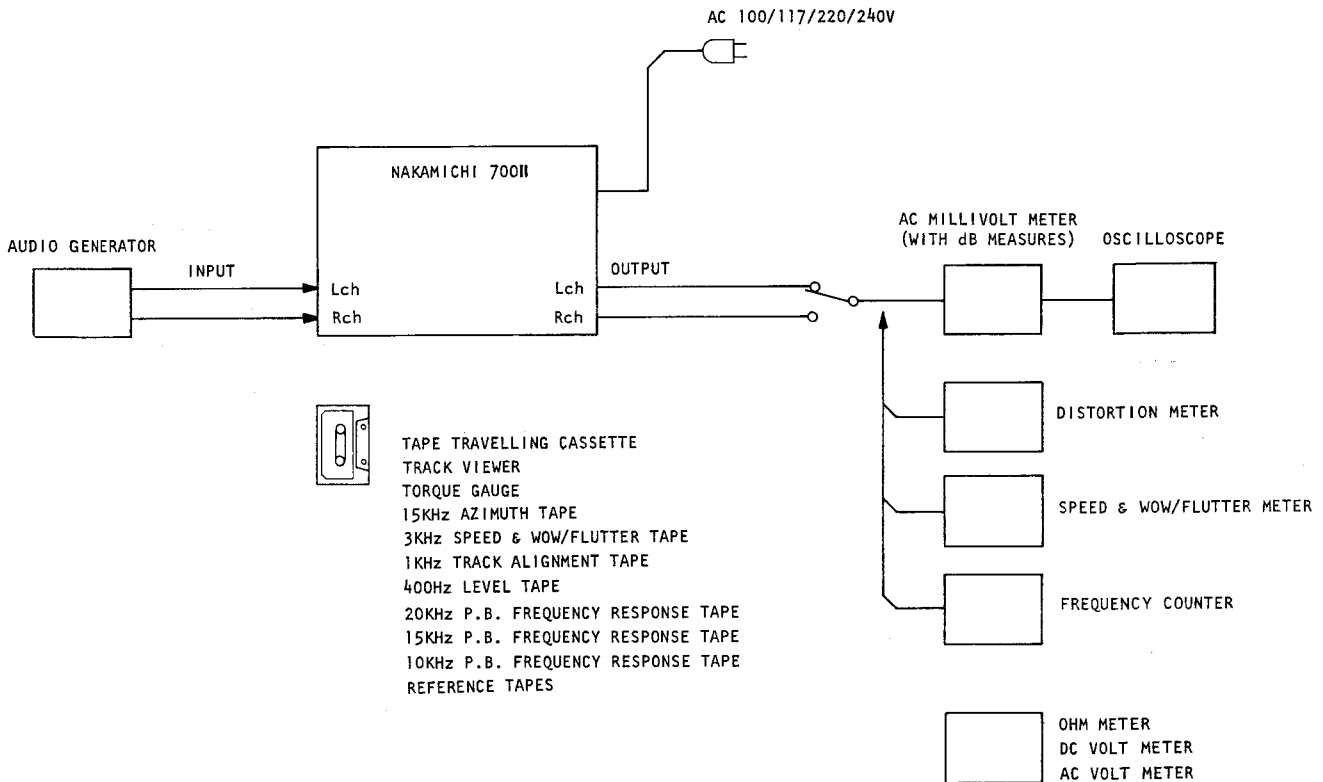

Fig. 5.1 Measurement Connection

5.2. Maintenance Instrument

Refer to Fig. 5.2 Extension Cord Connection.

- (1) Extension cord (19P-D) (DA09019A)
- (2) Extension cord (14P-PB) (DA09015A)
- (3) Extension cord (19P) (DA09014A) - 2 pcs.
- (4) Extension cord (14P) (DA09016A)

Note: When a check is made on Amp., etc. by means of an extension cord, re-adjustment shall be made without fail (after final installation to the Model chassis). The check without removal of an extension cord will cause inaccurate adjustments.

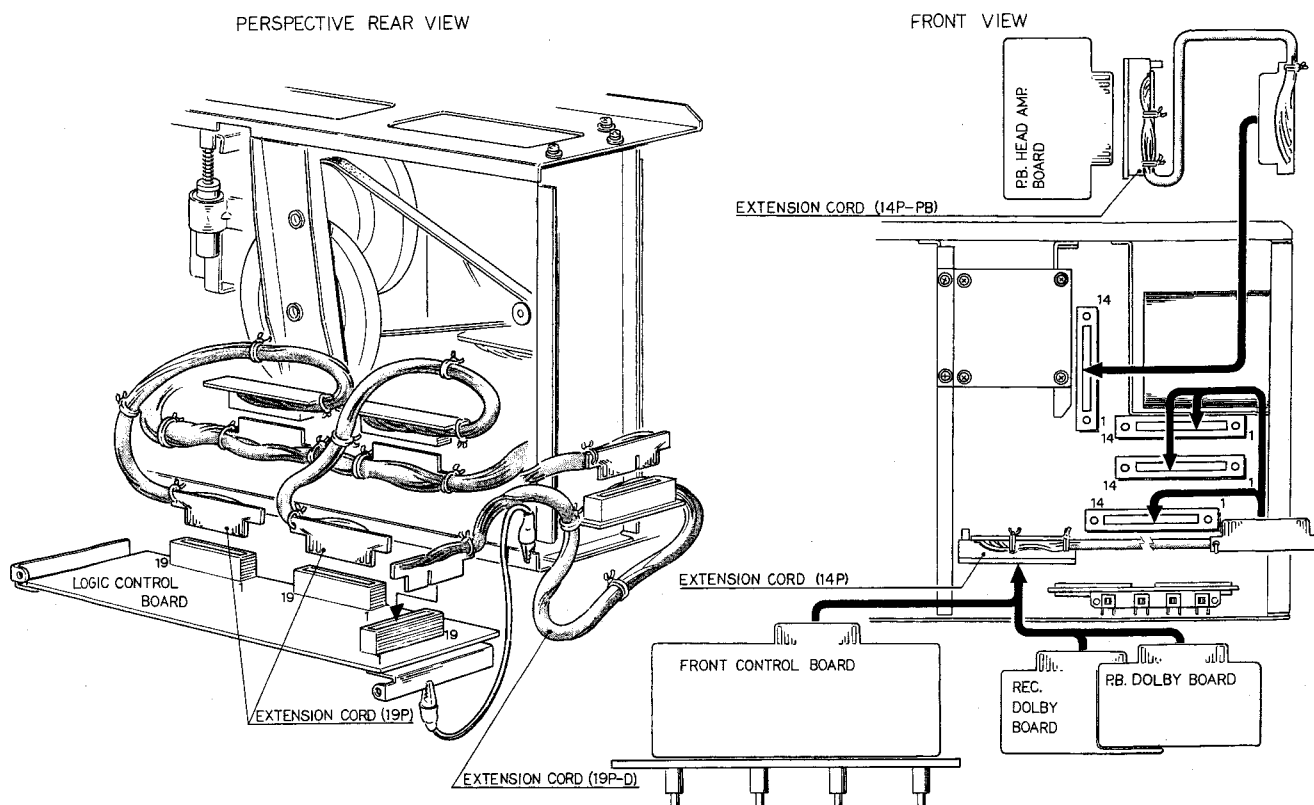

Note: Connect a cord between chassis and Logic Control P.C.B. as shown in the figure.

Fig. 5.2 Extension Cord Connection

6. MECHANICAL ADJUSTMENTS

6.1. Torque Adjustment

6.1.1. Torque Measurement

- (1) Using a torque gauge (DA09013A), measure the torque of fast-forward (F.F.), rewind and take-up modes.
- (2) F.F. and rewind torque should be 50 to 55 g-cm.
- (3) Take-up torque should be 40 ± 5 g-cm.

Note: When the torque is out of these ranges, adjust torque following the adjustment steps (In case the adjustment is not successful by observing these steps, replacement of ball drive assembly will be required. Refer to following "6.1.4. Ball Drive Assembly Replacement Procedures").

6.1.2. Torque Adjustment

- (1) Remove cabinet assembly, flywheel holder, capstan belt and two sets of flywheel assembly (including washer, flange thrust stud and thrust spring) in that order (When mounting the flywheel holder, use care to attach it in the correct direction to avoid the change of clearance between the flywheel holder and flywheel assembly).
- (2) Turn on the power.
- (3) Load the torque gauge (DA09013A) in the cassette well assembly.
- (4) By touching the button of F.F. or rewind, measure torque for each mode. Adjustment should be so made that the torque may become in a range from 50 to 55 g-cm. Adjustment should be made on brake drum assembly of forward side and reverse side, respectively, to regulate the torque of F.F. and rewind modes. Refer to Figs. 6.1 and 6.2.

Loosen screws 1 and 2 indicated in Fig. 6.2. and move up and down the brake drum assembly in order to adjust the torque. When the brake assembly is raised, the value of torque decreases. When lowered, the value is increased. Where specified torque is achieved, securely tighten the screws. Tighten first the screw 1 (with a part of the shaft end being flat) and then tighten the screw 2. Then apply a drip of lock tight paint to the screws.

- (5) Mount the flywheel assembly, capstan belt and flywheel holder. Check to insure that the clearance between the flywheel holder and the flywheel assembly is in a range of 0.05 to 0.1 mm. After installing the flywheel, be sure to clean oil off with an alcohol-dipped cloth from capstan which will be in contact with pressure roller.
- (6) Touch on the PLAY button to set the device in play mode.
- (7) Load the torque gauge to measure the take-up torque. Check whether the torque is in a range of 40 ± 5 g-cm. When the value is out of the range, readjustment of F.F. torque is necessary. Repeat from the step (1) and set the take-up torque to 40 ± 5 g-cm by

increasing the adjusted F.F. torque of 50 to 55 g-cm into a range of 45 to 60 g-cm. When doing this, set the rewind torque to almost the same range as that of F.F. torque to balance both of them.

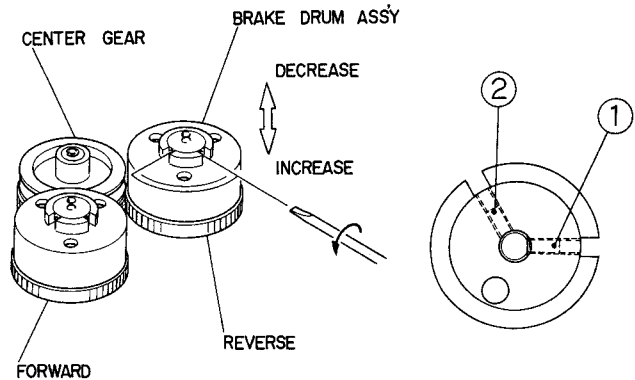

Fig. 6.1 Torque Adjustment

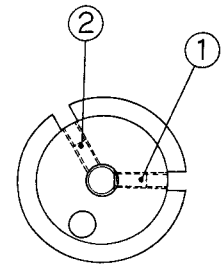

Fig. 6.2

6.1.3. Ball Drive Mechanism Ass'y Adjustment

- (1) Check the take-up torque (40 ± 5 g-cm) with a torque gauge.
- (2) Check shall be made on rewind and fast forward torque (within 50 to 55 g-cm).
- (3) Measure the time length while rewinding and fast forwarding.

Notes: 1. Where rewinding and fast forwarding exceed 60 seconds, adjust the torque of the ball drive mechanism ass'y.
2. Where the take-up torque should be too weak, adjust the ball drive mechanism ass'y referring to preceding 6.1.2. (7).

6.1.4. Ball Drive Mechanism Ass'y Replacement Procedures

- (1) Refer to Fig. 6.3. After removing the cabinet assembly, remove the counter belt and shut-off belt from the reel hub and hang them on the studs.
- (2) Remove flywheel holder, capstan belt and two sets of flywheel assembly (including washer, flange thrust stud and thrust spring). (When mounting the flywheel holder, use care to attach it in the correct direction to

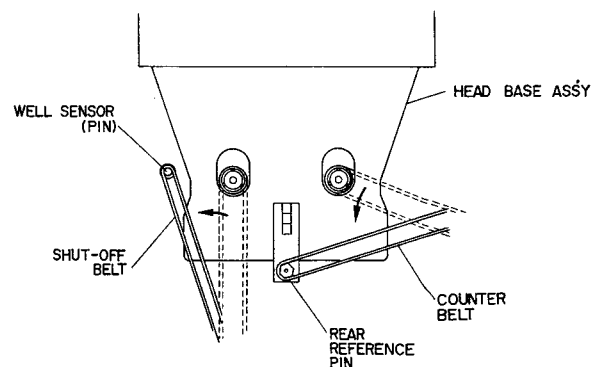

Fig. 6.3 Ball Drive Mechanism Ass'y Replacement

avoid the change of clearance between the flywheel holder and flywheel assembly.)

- (3) Referring to Fig. 6.4, remove the belt driven by the reel motor from the groove of the center gear. And remove three sets of screws and washers which fix the ball drive assembly to chassis. Detouch the brake assembly that holds the drum of ball drive assembly, and then remove the ball drive assembly.
- (4) Replace with a new ball drive assembly.
- (5) Mount the belt driven by the reel motor on the groove of center gear. Check to insure that the belt is clean and placed in a correct position.
- (6) Use care to prevent the shut-off belt from interfering with cassette holder assembly. Be sure that the belt is clean, and is placed in a correct position. Make sure not to stick grease on the counter belt. In case grease is stuck on the counter belt, clean it off with an alcohol-dipped cloth.
- (7) Without loading a cassette tape, check to insure that the reel hub on supply side and that on take-up side are stopped, respectively in F.F. mode and rewind mode (In case either one or both of them is not stationary, replacement of ball drive assembly will be necessary).
- (8) Loading the torque gauge in the cassette well assembly, check that F.F. and rewind torque are in a range of 50 to 55 g-cm. After mounting the flywheel assembly, capstan belt and flywheel holder, check to see that take-up torque is in a range of 40 ± 5 g-cm. In case these values are not achieved, adjustment should be made following the "6.1.2. Adjustment."

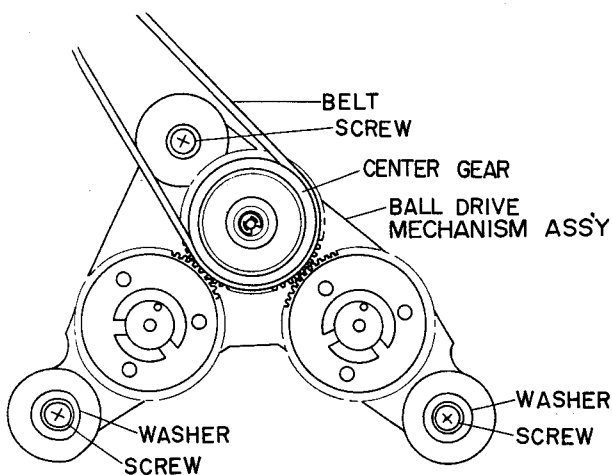

Fig. 6.4. Ball Drive Mechanism Ass'y Replacement

6.2. Tape Speed

Signal Source

3 kHz Speed Wow/Flutter Tape (DA09006A)

Measurement Connection

Frequency Counter to Output Jacks.

Mode

CONTROL BUTTON – Playback

MONITOR SW – TAPE

TAPE SELECTOR SW – SX

EQ SELECTOR SW – 70 μ s

Adjustment

- (1) Set the Pitch Control Knob to "0" position.
- (2) Adjust the Speed Control VR502 to obtain 3 kHz on Frequency Counter.

VR502 Capstan Motor Governor P.C.B.

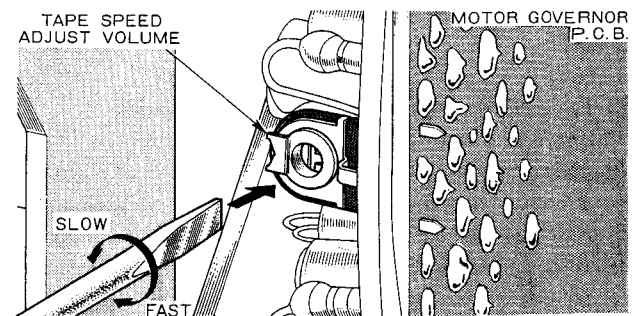

Fig. 6.5. Tape Speed Adjustment

6.3. Head Base Damper Adjustment

- (1) Slowly turn the exhaust adjusting screw clockwise repeatedly depressing and releasing the damper piston by hand. Set the screw at such an initial position that the piston cannot be depressed into the inmost end by the decreased damper pressure.
- (2) Return the screw approximately 90 degrees counter-clockwise from the set position given in Step (1) above. Check to insure whether the head base is smoothly locked by repeatedly playing back and stopping the tape feed mechanism. If the double motion or associated shock is too strong, further precise adjustment is required.

Note: Do not tighten the exhaust adjusting screw excessively as it may be damaged.

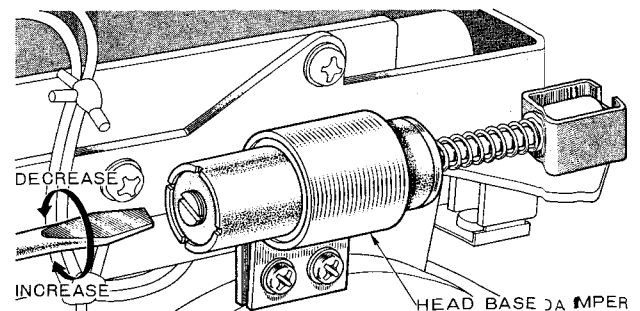

Fig. 6.6. Head Base Damper Adjustment

6.4. Eject Damper Adjustment

Install the cassette compartment lid. Adjust the exhaust adjusting screw at the eject damper ass'y until it takes 0.5 to 1.0 second to stop the lid eject movement after the eject push button is depressed.

Note: Do not tighten the exhaust adjusting screw excessively as it may be damaged.

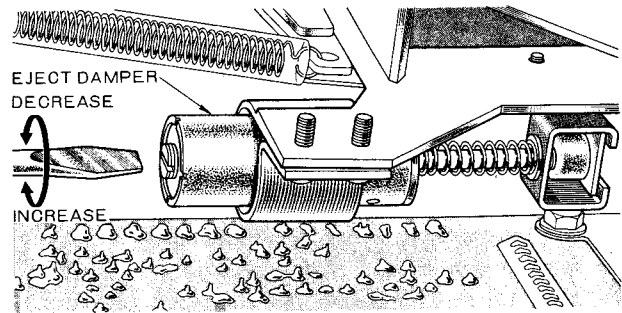

Fig. 6.7 Eject Damper Adjustment

6.5. Headblock

Adjustment should be made in accordance with Fig. 6.11 Flow Chart.

6.5.1. Head Mount Base Ass'y Removal Procedures

- (1) Remove the Adjustment Lid and Cassette Lid.
- (2) Referring to Fig. 6.8, remove Pitch Control Knob (1) and screws (2), then disassemble Mount Base Name Plate (3). Remove screw (4) then disassemble Mount Base Cover Ass'y (5). Remove screws (6 - 3 places), then disassemble Head Mount Base Ass'y.

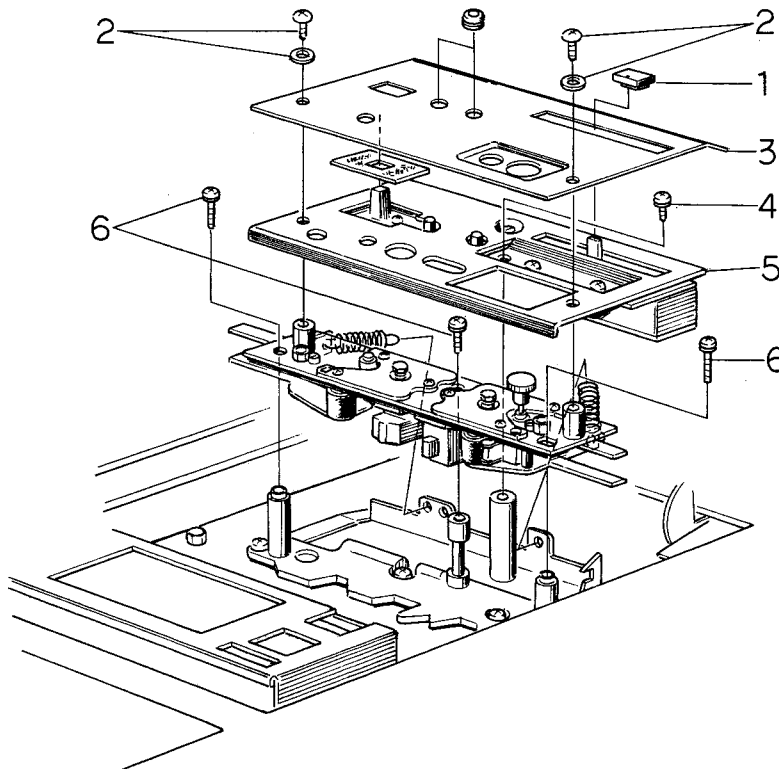

Fig. 6.8. Head Mount Base Ass'y

6.5.2. Head Replacement Procedures

- (1) Referring to Fig. 6.9, unfasten screws and springs (12,11) then remove record head (05) and playback head (06) with care not to lose washers or steel balls (L04,08).
 - (2) Disassemble E-ring, spring and collar (L01,01,02), then remove supply pressure roller arm ass'y (03).
 - (3) Remove erase head from supply pressure roller arm ass'y (03).
 - (4) Referring to Fig. 6.10. disconnect signal wires then replace each head.
 - (5) Fasten screws (12 in Fig. 6.9) of playback and record heads, insuring to keep correct direction, vertically against to the cassette tape.
 - (6) Fasten a screw fixing an erase head to the chassis of the supply pressure roller arm ass'y without any dust, and pushing erase head toward the pressure roller insuring to keep more than 0.1 mm space. Then apply a drip of lock tight paint to the screw. Check to insure signal wires are not in contact with the chassis.
- Notes:
1. Separation of signal wires between record and playback heads will be required for avoiding bias leakage or cross feed caused by interference.
 2. When replacing the heads, be careful not to contaminate dust or any other foreign materials on the head surface; otherwise, the head installation angle may deviate, resulting in irregular tape travelling.
 3. Handle the heads with care not to give damages on the surface.
- (7) After replacement of each head the following adjustments are required.

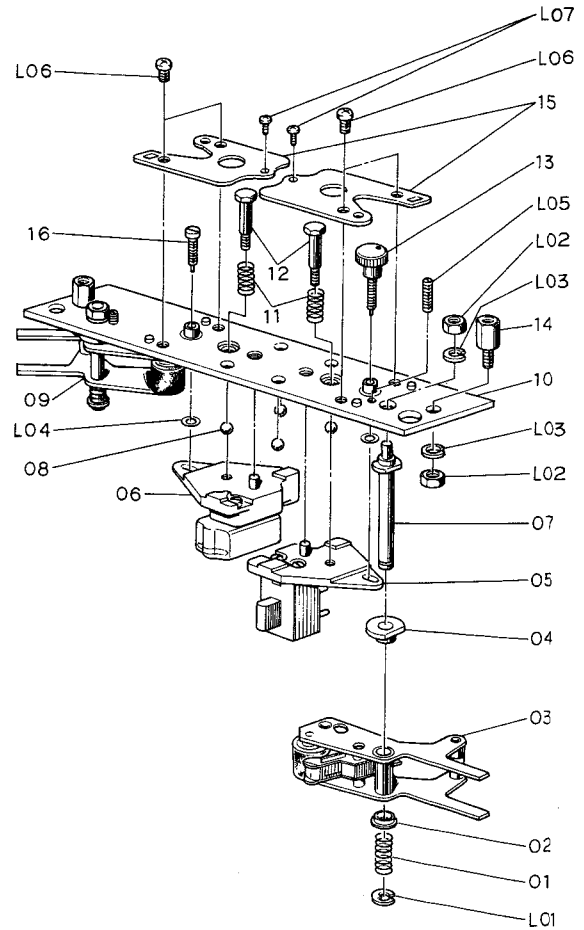

Fig. 6.9. Head Replacement

Mechanical Adjustment:

Following items from 6.5.3 to 6.5.9 (adjustment of each head).

Electrical Adjustment:

Playback Head

- 7.5. Playback Level Calibration
- 7.6. Playback Frequency Response
- 7.7. Head Azimuth Alignment (Playback Head)
- 7.12. Record Bias and Record/Playback Level

Record Head

- 7.10. Recording Equalization Peaking
- 7.12. Record Bias and Record/Playback Frequency

Erase Head

- 7.8. Bias Oscillator Frequency

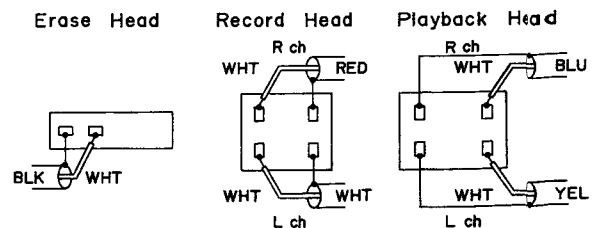

Fig. 6.10 Wiring of Heads (Rear View)

6.5.3. Tape Guide Height Adjustment

- (1) Load with care the Tape Guide Height Measurement Jig (Model No. M300 from Information Terminals).
- (2) Refer to Fig. 6.12. and adjust the tape guide height adjusting screw A so that the tape guide may become fixed to the jig.
One turning (one rotation) becomes 0.45 mm tape guide height movement.

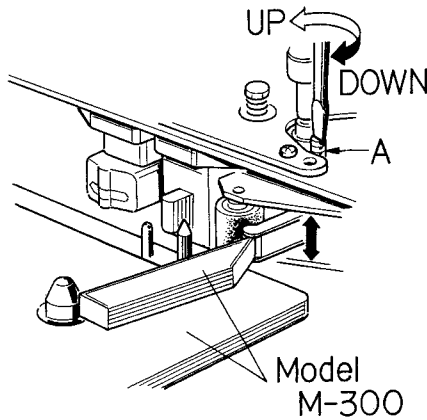

Fig. 6.12 Tape Guide Height Adjustment

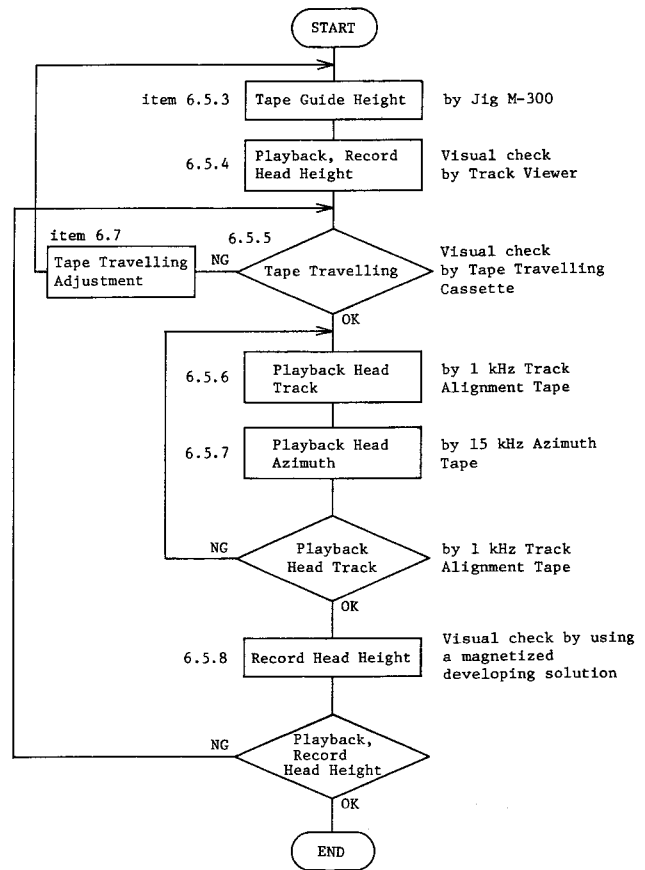

Fig. 6.11 Headblock Adjustment Flow Chart

6.5.4. Head Height Adjustment

- (1) Load the Track Viewer (DA09012A), and check the positions of playback and record heads. While adjustment, check to insure that the L-R center of each head coincides in position with the middle point between two lines (0.3 mm distance) on the Track Viewer.
- (2) If the L-R center deviates from the middle point, refer to Fig. 6.13. and correct the head height deviation by adjusting screws E and F, together with adjusting C and D for correcting head azimuth.

6.5.5. Tape Travelling Check

- (1) Load the Tape Travelling Cassette (DA09011A), and set to the playback mode.
- (2) Check to insure that the tape height while running is within ± 0.3 mm at any tape position when measured from the center of a cassette housing.

Note: Observing tape travelling on the playback head, check the following points:

- a. Tape travelling does not wave.
- b. At a tape starting point, the tolerance of tape travelling fluctuation is within about ± 0.3 mm.

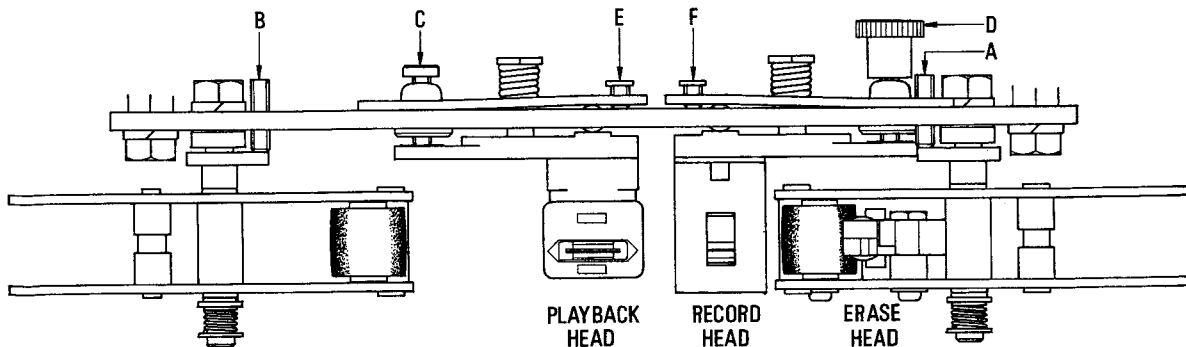

Fig. 6.13 Head Height/Azimuth Adjustment

If not, adjust the pressure roller height by adjusting screw B located at the take-up reel side. After the tape travel is corrected, check to insure that the pressure roller position is within ± 1 mm when measured from the center of a cassette housing. Note that in most cases of playback head adjustment turning of the screw B will not be required for misalignment. If tape travel cannot still be adjusted, adjust the tape travelling referring to "6.7. Tape Travelling".

6.5.6. Playback Head Track Alignment

- (1) Load the 1 kHz Track Alignment Tape (DA09007A) and check the head height on the cassette tape deck. Set the MONITOR SW to TAPE and play the tape back.
- (2) Adjust the playback head height screw E until each level meter of both channels reads the minimum value.

6.5.7. Playback Head Azimuth Alignment

- (1) Load the 15 kHz Azimuth Tape (DA09004A) for adjusting the playback head azimuth. Set the MONITOR SW to TAPE position and playback.
- (2) Adjust the playback head azimuth alignment screw C until each level meter of both channels reads the maximum value.
- (3) After completion of the adjustment in this step, check the item 6.5.6 "Playback Head Track Alignment" then recheck playback head azimuth.

6.5.8. Record Head Height Alignment

- (1) Load the Reference SX tape (DA09025A), set the TEST TONE SW to ON position and TAPE SELECTOR SW to the TAPE position. Set to record mode and adjust record head azimuth alignment screw D until the alignment beacon started flickering alternately.
- (2) Aligning Step (1) as above, align the screw F to obtain maximum reading of both channels.
- (3) Record the same portion of the both A and B sides of the tape after record head azimuth is aligned.
- (4) Immerse the recorded tape in a magnetized developing solution. In turn, check to insure that the recording head tracks across the center are separated with a distance of 0.4 to 0.6 mm typically 0.5 mm as illustrated in Fig. 6.14.

Note: Liquid for tape magnetized development: "MAGNA-SEE, SOUND CRAFT a product of CBS RECORDS a division of Columbia Broadcasting System, Inc., Danbury, Conn. 06810, or equivalent".

After development, clean the tape otherwise pressure roller will become dirty.

The above development will not be required if the difference of playback and record head heights are within 0.1 mm at "6.5.4. Head Height Adjustment".

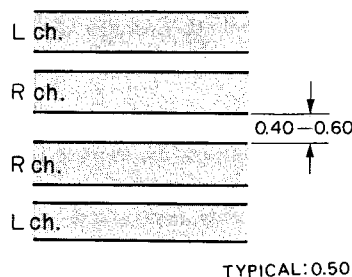

Fig. 6.14 Record Head Track

6.5.9. Erase Head Adjustment

After removal of erase head, refer to "6.5.2. Head Replacement Procedures".

6.6. Flywheel Adjustment

When mounting the flywheel holder, adjust the flywheel clearances should be 0.05 to 0.1 mm.

Caution: When installing the flywheel, be sure to clean oil off with an alcohol-dipped cloth from capstan which will be in contact with pressure roller.

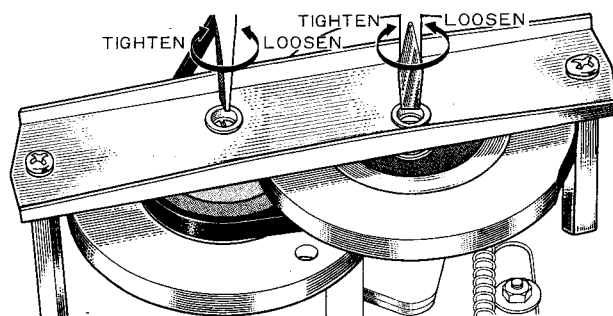

Fig. 6.15 Flywheel Adjustment

6.7. Tape Travelling Adjustment

Inaccurate tape travelling extremely deteriorates the performance of tape decks therefore careful checks are required.

6.7.1. Check-out Method

- (1) Check to insure whether the head height is correct.
- (2) Load a Tape Travelling Cassette (DA090011A) and play it and check to insure freedom from wavering, looseness, etc.
- (3) The difference of head height between supply side and take-up side shall not be more than 0.3 mm.
- (4) After more than 2 seconds when play button is touched on, tolerance of the tape on the playback head shall not be more than 0.05 mm.
- (5) Feed in the test tone signals to the Reference SX Tape (DA09025A) and record and play it back, when the level change shall not be more than 1 dB.

6.7.2. Adjustment

- (1) Check to insure whether any of the heads is not in contact with the cassette housing.
- (2) Check to insure whether the pressure roller is located in parallel with the capstan shaft (Also check to insure whether the heads are free from dust or dirt, and whether the pressure roller arm is free from bending).
- (3) Check to insure whether the surface of the pressure roller is globular, not straight. Other than the above, concaved, or oiled surface shall be subject to replacement.
- (4) The pressure of the pressure roller shall be $400 \text{ g} \pm 50 \text{ g}$.
- (5) Adjustment of Pressure Roller Timing.
 - a. Refer to Fig. 6.16.

Push down the head base by hand while in stop mode till the take-up pressure roller reaches the capstan, and then check to insure whether the gap between the supply pressure roller and the capstan is 0.5 mm.
 - b. While in play mode, check to insure whether the gap between the take-up pressure roller arm and the stopper is 1.25 mm, and whether the gap between the supply pressure roller arm and stopper is 0.75 mm.

Note: If the foregoing requirements are not satisfied, adjustment shall be made by bending the stopper.
- (6) The clearance between the capstan shaft and thrust shall be 0.1 – 0.05 mm.
- (7) The tape guide on which if any scratches, etc. are noted shall be replaced. Check shall also be made to insure whether the erase head surface is smooth.
- (8) The use of defective head base damper will deteriorate the tape travel at the beginning of activation.

- (9) The parallelism between both of the capstan axis is one of the most important factors for an accurate operation. If great shock is given to the capstan, the capstan flange ass'y shall be replaced.

Note: The cassette house shall also be checked to insure freedom from deformation, bending, etc.

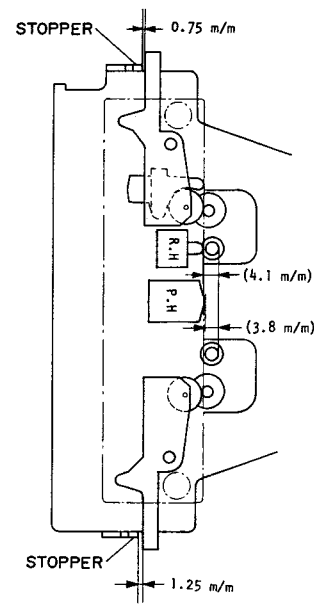

Fig. 6.16. Pressure Roller Adjustment

6.8. Lubrication

Place the deck in a horizontal position and then remove the cassette lid.

Apply a few drops of oil (LAUNA NO. 40) into the oil cap hole of the capstan flange every 500 hours of use.

Note: If the lubricating oil is applied also to the capstan shaft and other drive mechanisms, clean it off with an alcohol-dipped cloth.

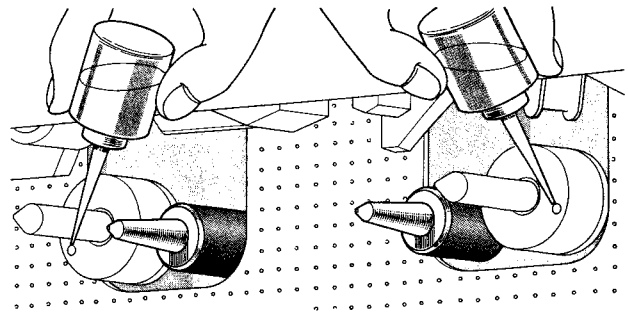

Fig. 6.17. Lubrication

7. ELECTRICAL ADJUSTMENTS AND MEASUREMENTS

Note: Mechanical adjustments have to be performed prior to this adjustment. Refer to Figs. 8.1 – 8.3 position of semi-fixed volume and test point.

7.1. Adjustments and Measurements Table

STEP	ITEM	REMARKS
1	Fast Forward, Rewind Torque Take-up Torque	As per 6.1. 50 – 55 g-cm As per 6.1. 40 ± 5 g-cm
2	Tape Travelling Check	As per 6.5.5 by Tape Travelling Cassette
3	Tape Speed	As per 6.2. 1-7/8 ips ± 1%
4	Meter Level Calibration	As per 7.2. 0 dB on level meters, at 100 mV ± 2 mV input to Test Points TP1, TP2
5	400 Hz Test Tone	As per 7.3. 0 dB on level meters
6	19 kHz MPX Filter	As per 7.4. Minimum reading at 19 kHz
7	Playback Level Calibration	As per 7.5. 0 dB on level meters by 400 Hz level Tapes (Adjust when Playback Head is replaced.)
8	Playback Frequency Response	As per 7.6. -20 dB ± 3 dB against 400 Hz Level Tape by 10, 15 and 20 kHz Playback Reference Tapes (Adjust when playback Head is replaced.)
9	Head Azimuth (Playback Head)	As per 7.7. Maximum reading by 15 kHz Azimuth Tape (Adjust when Playback Head is replaced.)
10	Bias Oscillator Frequency	As per 7.8. 105 kHz ± 3 kHz (Adjust when Erase Head is replaced.)
11	Bias Trap (Record Amp./Playback Amp.)	As per 7.9.1. and 7.9.2. Minimum reading
12	Recording Equalization Peaking	As per 7.10. Peak reading at 23 kHz with bias cut mode (Adjust when Record Head is replaced.)
13	Alignment-Beacon Phase	As per 7.11.
14	Record Bias and Record/Playback Level	As per 7.12. Frequency Response: -20 dB ± 3 dB Distortion: Less than 1.5% (Adjust when Playback or Record Head is replaced.)
15	Record Dolby NR Playback Dolby NR	As per 7.13. As per 7.14.
16	Frequency Response Playback Frequency Response Overall Frequency Response	As per 7.15.1. As per 7.15.2.
17	Signal-to-Noise Ratio	As per 7.16. Better than 65 dB (Dolby NR IN, Wrms, CCITT, 400 Hz, 3% distortion)
18	Channel Separation	As per 7.17. Better than 35 dB at 1 kHz 0 dB
19	Crosstalk	As per 7.18. Better than 60 dB at 1 kHz 0 dB
20	Erasure	As per 7.19. Better than 60 dB at 1 kHz saturation level
21	Total Harmonic Distortion	As per 7.20. Less than 1.5% at 400 Hz 0 dB
22	Wow/Flutter	As per 7.21. Less than 0.1% (DIN 45507 Weighted Peak)

7.2. Meter Level Calibration

Signal Source

1 kHz 0.3 V to Input Jacks or 1 kHz 0.03 V to DIN input.

Measurement Connection

VTVM to Test Point

TP1 (Main P.C.B.) – GND (Lch),
TP2 (Main P.C.B.) – GND (Rch).

Mode

MONITOR SW – SOURCE

Adjustment

- Adjust the line input level controls to obtain 100 mV \pm 2 mV on VTVM.
- Adjust the Meter Calibration VR155, 255 to obtain 0 dB on Level Meters.

VR155 (Lch) Main P.C.B.
VR255 (Rch)

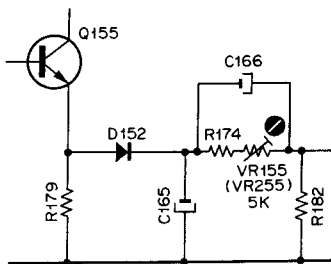

Fig. 7.1 Meter Level Calibration

7.3. 400 Hz Test Tone

Mode

MONITOR SW – SOURCE
400 Hz TEST TONE SW – ON

Adjustment

Adjust the Tone Calibration VR351 so that the level meter of the L channel indicates 0 dB.

VR351 Main P.C.B.

Note: If the level meters of the L and R channels are not balanced, modification of R175 or R275 on the Main P.C.B. will be required.

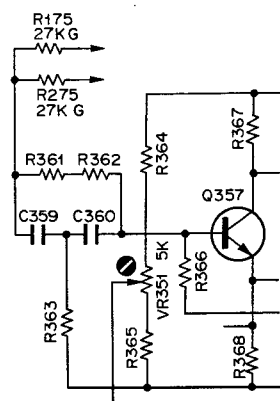

Fig. 7.2 400 Hz Test Tone

7.4. 19 kHz MPX Filter

Signal Source

19 kHz 0.3 V to Input Jacks or 0.03 V to DIN Input.

Measurement Connection

VTVM and Frequency Counter to Output Jacks or DIN Output.

Mode

MONITOR SW – SOURCE
MPX SW – OFF
DOLBY NR SW – OUT

Adjustment

- Adjust the line input level controls to obtain 0 dB (1 V) on Level Meters and VTVM.
- Set the MPX SW to ON.
- Adjust MPX Filter Coils L154, 254 to obtain the minimum reading on VTVM.

L154 (Lch) Main P.C.B.
L254 (Rch)

Note: Frequency has to be 19 kHz \pm 100 Hz on Frequency Counter.

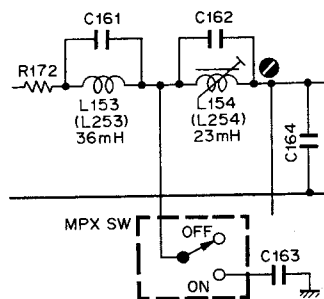

Fig. 7.3 19 kHz MPX Filter

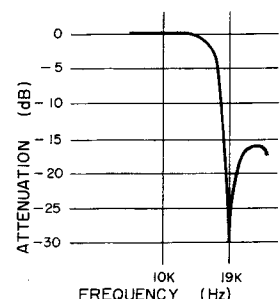

Fig. 7.4 Characteristics

7.5. Playback Level Calibration

Signal Source

400 Hz Level Tape (DA09005A)

Mode

CONTROL BUTTON – Playback
MONITOR SW – TAPE
TAPE SELECTOR SW – SX
EQ SELECTOR SW – 70 μ s

Adjustment

Adjust the Playback Amp. Potentiometers VR101, 201 till the level meters indicate 0 dB.

VR101 (Lch) PB Head Amp. P.C.B.
VR201 (Rch)

Note: "7.2. Meter Level Calibration" to be completed prior to 7.5 as above.

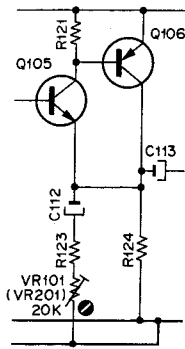

Fig. 7.5 Playback Level Calibration

7.6. Playback Frequency Response

Measurement Connection

VTVM to Output Jacks or DIN Output.

Mode

- MONITOR SW – TAPE
- TAPE SELECTOR SW – SX
- EQ SELECTOR SW – 70 μ s
- DOLBY NR SW – OUT

Adjustment

- (1) Load a 400 Hz Level Tape (DA09005A) and play it back.
Adjust the line output level controls to a certain level (example 0 dB).
- (2) Load a 10 kHz PB Frequency Response Tape (DA09003A), 15 kHz PB Frequency Response Tape (DA09002A) and 20 kHz PB Frequency Response Tape (DA09001A), and adjust the playback head azimuth to give the maximum levels on VTVM with each Tape.
Check to insure level would be within $-20 \text{ dB} \pm 3 \text{ dB}$ against 400 Hz Level Tape.
- (3) If above level cannot be satisfied.
Refer to "7.15.1. Playback Frequency Response Adjustment".
- (4) Load a 15 kHz Azimuth Tape (DA09004A).
Adjust the playback head azimuth to give the maximum levels on VTVM.

7.7. Head Azimuth Alignment (Playback Head)

Signal Source

15 kHz Azimuth Tape (DA09004A)

Measurement Connection

VTVM to Output Jacks.

Mode

- CONTROL BUTTON – Playback
- MONITOR SW – TAPE
- TAPE SELECTOR SW – SX
- EQ SELECTOR SW – 70 μ s
- DOLBY NR SW – OUT

Adjustment

Adjust the Playback Head Azimuth Alignment Screw to obtain the maximum reading on VTVM. Be sure to

check both channels. The maximum reading should be more than 70 mV on VTVM when Playback Level Calibration described in 7.5 is adjusted correctly.

7.8. Bias Oscillator Frequency

Measurement Connection

Frequency Counter to Test Point CN1-9 (Main P.C.B.) – GND

Mode

CONTROL BUTTON – Record/Pause

Adjustment

Adjust the Bias Oscillator Coil T351 to obtain a reading of 105 kHz on Frequency Counter.

T351 Main P.C.B.

Note: Measurement shall be made by use of a low capacity probe.

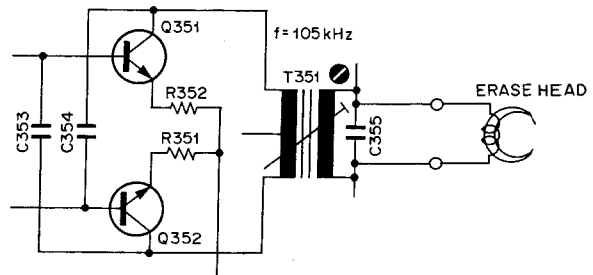

Fig. 7.6. Bias Oscillator

7.9. Bias Trap (Bias Leakage)

Measurement shall be made by use of a low capacity probe.

7.9.1. Record Amp. Bias Trap

Measurement Connection

VTVM to

- Q153 Collector (Main P.C.B.) – GND (Lch),
- Q253 Collector (Main P.C.B.) – GND (Rch).

Mode

CONTROL BUTTON – Record/Pause

Adjustment

Adjust the Bias Trap Coils L152, 252 to obtain the minimum reading on VTVM.

- L152 (Lch)
- L252 (Rch) Main P.C.B.

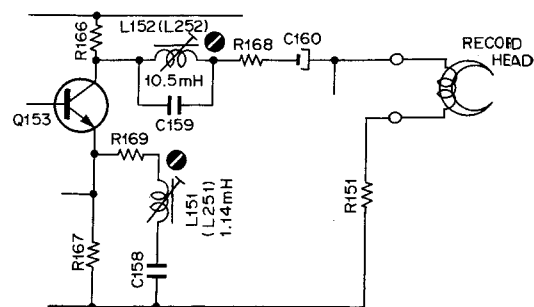

Fig. 7.7. Record Amp. Bias Trap

7.9.2. Playback Amp. Bias Trap

Measurement Connection

- VTVM to Test Point
- TP3 (Main P.C.B.) – GND (Lch),
- TP4 (Main P.C.B.) – GND (Rch).

Mode

- CONTROL BUTTON – Record/Pause
- MONITOR SW – TAPE

Adjustment

Adjust the Bias Trap Coils L101, 201 to obtain the minimum reading on VTVM.

- L101 (Lch) PB Head Amp. P.C.B.
- L201 (Rch)

7.10. Recording Equalization Peaking

Signal Source

- 1 kHz and 23 kHz 0.3 V to Input Jacks or 1 kHz and 23 kHz 0.03 V to DIN Input.

Measurement Connection

- VTVM to Test Point
- TP5 (Main P.C.B.) – GND (Lch),
- TP6 (Main P.C.B.) – GND (Rch).

Mode

- CONTROL BUTTON – Record/Pause
- MONITOR SW – SOURCE
- TAPE SELECTOR SW – SX
- EQ SELECTOR SW – 70 μ s
- DOLBY NR SW – OUT
- MPX SW – OFF
- BIAS CUT (Disconnect Bias-Cut Jumper in the Main P.C.B. from the dip side.)

Adjustment

- (1) Adjust the line input level controls to obtain 0 dB on Level Meters at 1 kHz input signals.
- (2) Feed in 23 kHz instead of 1 kHz then adjust L151, 251 to obtain peak reading (about 13 dB rise at 20 kHz).

- L151 (Lch) Main P.C.B.
- L251 (Rch)

Note: Refer to Fig. 7.10, frequency response curve.

7.11. Alignment Beacon Phase Adjustment

Before starting adjustment, be sure to adjust the record head azimuth by Record Head Azimuth Alignment Beacon whenever cassette tapes are changed (even when cassette tape is changed from A-side to B-side).

Signal Source

- 15 kHz 0.03 V to Input Jacks or 15 kHz 3 mV to DIN Input.

Mode:

- CONTROL BUTTON – Record/playback
- MONITOR SW – TAPE
- TAPE SELECTOR SW – SX
- EQ SELECTOR SW – 70 μ s
- 400 Hz TEST TONE SW – OFF

Adjustment

- (1) Load a Reference SX Tape (DA09025A) then set to record/playback mode.
 - (2) Adjust the Record Head Azimuth Alignment Screw to obtain the maximum reading on VTVM. Be sure to check both channels.
 - (3) Set 400 Hz TEST TONE SW to ON.
 - (4) Adjust VR601 so that Alignment Beacon will flicker alternately.
- VR601 Logic Control P.C.B.

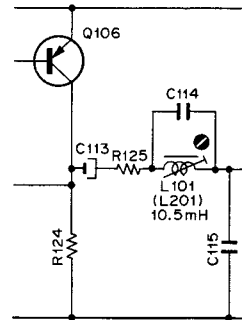

Fig. 7.8 Playback Amp. Bias Trap

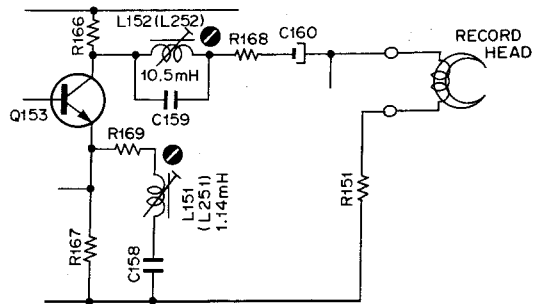

Fig. 7.9 Recording Equalization Peaking

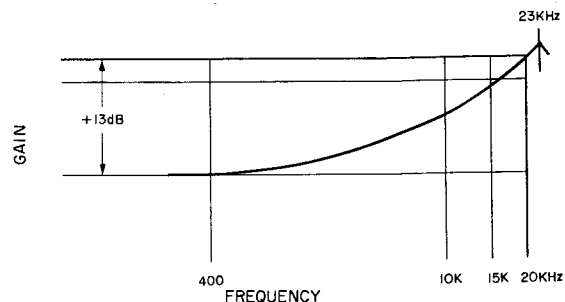

Fig. 7.10 Recording Equalization Peaking Characteristics

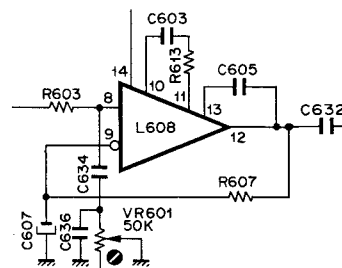

Fig. 7.11 Alignment Beacon Phase Adjustment

7.12. Record Bias and Record/Playback Level

Signal Source

1 kHz 0.3 V, 20 kHz 0.03 V (-20 dB), or 1 kHz 0.03 V (-20 dB) to Line Input Jacks.

Measurement Connection

VTVM and Distortion Meter to Output Jacks or DIN Output.

Mode

- CONTROL BUTTON – Record/Playback
- MONITOR SW – SOURCE/TAPE
- TAPE SELECTOR SW – EX (SX)
- EQ SELECTOR SW – 120 μ s (70 μ s)
- DOLBY NR SW – OUT
- MPX SW – OFF

Adjustment

- (1) Load a Reference EXII Tape (DA09021A) (Reference SX Tape (DA09025A)) and set TAPE SELECTOR SW to EX (SX) and EQ SELECTOR SW to 120 μ s (70 μ s).
- (2) Set to TEST TONE SW ON and set to record mode, and adjust the record head azimuth alignment.
- (3) Set MONITOR SW to TAPE, and adjust the Bias Adj. VR154, 254 (VR153, 253) to obtain the maximum reading on VTVM.
- (4) Adjust the Record Calibration VR101, 201 (VR102, 202) on the Rec. Cal. P.C.B. to obtain same level on Level Meters (0 dB) at MONITOR SW SOURCE and TAPE.
- (5) Set MONITOR SW to SOURCE and TEST TONE SW to OFF. Feed in 1 kHz 0.3 V to Input Jacks and adjust the line input level controls to obtain 0 dB on Level Meters.
- (6) Set MONITOR SW to TAPE. Set Audio Generator Output Level to 20 kHz -20 dB (EXII/SX). Adjust the Bias Adj. VR154, 254 (VR153, 253) so that level would become within ± 3 dB against 1 kHz.
- (7) Set MONITOR SW to TAPE. Feed in 1 kHz 0.3 V to Input Jacks and adjust the line input level controls to obtain 0 dB on Level Meters. And check whether the Total Harmonic Distortion (T.H.D.) is under 1.5%. If T.H.D. exceeds 1.5%, adjust the Bias Adj. VR154, 254 (VR153, 253) again to obtain T.H.D. of less than 1.5%, then set Audio Generator Output Level to 20 kHz -20 dB (EXII/SX) and check to insure whether the level becomes within ± 3 dB against 1 kHz -20 dB.
- (8) For correction of Record Calibration after above adjustment, set to TEST TONE SW ON and set to record mode. Then adjust Record Calibration VR 101, 201 (VR102, 202) on the Rec. Cal. P.C.B. to obtain same level on Level Meters (0 dB) at MONITOR SW SOURCE and TAPE.

Notes:

1. "7.11. Alignment Beacon Phase Adjustment" has to be conducted.

2. In case of defective Frequency Response, the following causes can be considered:

Defective Record Head, defective "7.6. Playback Frequency Response" check and Playback Head, defective "7.10 Recording Equalization Peaking" check, defective Mechanical Adjustments (Head Height Adjustment, Tape Travelling). Refer to "7.15. Frequency Response Adjustment".

Main P.C.B.:

- VR154 (EXII Bias Adj. VR – Lch)
- VR254 (EXII Bias Adj. VR – Rch)
- VR153 (SX Bias Adj. VR – Lch)
- VR253 (SX Bias Adj. VR – Rch)

Rec. Cal. P.C.B.:

- VR101 (EXII Rec. Cal. VR – Lch)
- VR201 (EXII Rec. Cal. VR – Rch)
- VR102 (SX Rec. Cal. VR – Lch)
- VR202 (SX Rec. Cal. VR – Rch)

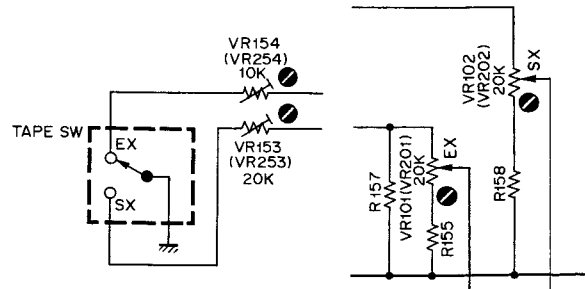

Fig. 7.12 Bias Current Adjustment

Fig. 7.13 Record Level Calibration

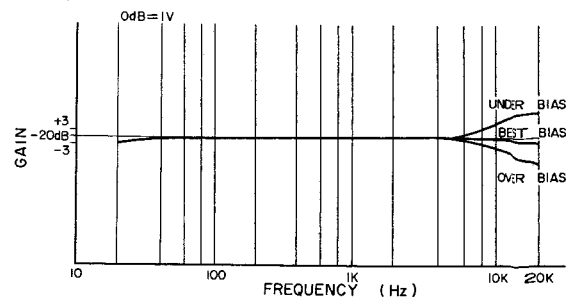

Fig. 7.14 Frequency Response

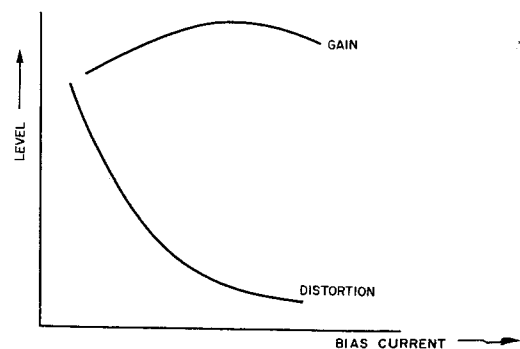

Fig. 7.15 Bias Characteristics

7.13. Record Dolby NR Alignment

Adjust only if Record Dolby NR P.C.B. is repaired.

- (1) Set Law Control VR101 (VR201) fully clockwise, viewed from top side.
- (2) Set Gain Control VR102 (VR202) fully counter-clockwise.
- (3) Set DOLBY NR SW to OUT and short FET gate Test Pin Lch (Rch) to ground.
- (4) Feed in 5 kHz at a level to give 3 mV at Metering terminal.
- (5) Note signal level obtained at Output terminal.
- (6) Set DOLBY NR SW to IN and adjust Gain Control for a 10 dB rise at Output terminal.
- (7) Note output level with DOLBY NR SW IN.
- (8) Remove FET gate Test Pin short and adjust Law Control for a 2 dB drop at Output terminal.

Note: Pin numbers of Record Dolby NR P.C.B.

	Right	Left
DOLBY NR SW terminal	2	13
Metering terminal	3	12
Output terminal	5	10
Input terminal	4	11

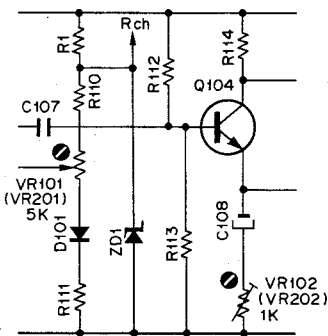

Fig. 7.16 Record Dolby NR Alignment

7.14. Playback Dolby NR Alignment

Adjust only if Playback Dolby NR P.C.B. is repaired.

- (1) Set Law Control VR101 (VR201) fully clockwise, viewed from top side.
- (2) Set Gain Control VR102 (VR202) fully counter-clockwise.
- (3) Set DOLBY NR SW to OUT and short FET gate Test Pin Lch (Rch) to ground.
- (4) Feed in 5 kHz at a level to give 7.6 mV at Metering terminal.
- (5) Set Gain Control for a 10 dB drop at Metering terminal as DOLBY NR SW is set to IN.
- (6) Set DOLBY NR SW to OUT and remove FET gate Test Pin short and adjust Law Control to give a reading of 3 mV at Metering terminal.

Note: Pin numbers of Playback Dolby NR P.C.B.

	Right	Left
DOLBY NR SW terminal	2	13
Metering or Output terminal	5	10
Input terminal	3	12

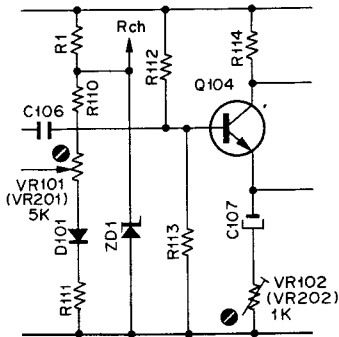

Fig. 7.17 Playback Dolby NR Alignment

7.15. Frequency Response Adjustment

7.15.1. Playback Frequency Response

Measurement Connection

VTVM to Line Output Jacks.

Mode

MONITOR SW – TAPE

TAPE SELECTOR SW – SX

EQ SELECTOR SW – 70 μ s

DOLBY NR SW – OUT

Adjustment

- (1) Open 22 k Ω of R109,209 of the PB Head Amp. P.C.B. (EQ and time constant shall show 120 μ s).
- (2) Load a 400 Hz Level Tape (DA09005A) to playback, and turn the output level controls till the indication of the VTVM shows 0 dB (for example) or easy reference of value.
- (3) Load a 10 kHz PB Frequency Response Tape (DA09003A) and play it back.
- (4) Check the output of 10 kHz and then, referring to Fig. 7.18, adjust EQ in the range of 110 μ s – 140 μ s, the result of which shall be 0 to + 3 dB.
- (5) Load a 15 kHz PB Frequency Response Tape (DA09002A) and play it back.
- (6) If the output of 15 kHz shows the value within \pm 2 dB against 400 Hz Level Tape, it is considered satisfactory.
- (7) Load a 20 kHz PB Frequency Response Tape (DA09001A) and play it back.
- (8) If 15 kHz at (5) shows the value within \pm 2 dB and 20 kHz being less than -3 dB, replace the playback head.
- (9) Adjustment shall be made so that the level at 10 kHz, 15 kHz and 20 kHz will become flat when compared with 400 Hz.

(10) If the results are shown to belong to high, set R101,201 to open – 100 k Ω . Refer to Fig. 7.19.

(11) Adjust the azimuth alignment to the maximum output with a 15 kHz Azimuth Tape (DA09004A).

Notes: 1. If adjustment is made on the jumper resistor, the alignment beacon phase shall also be adjusted.

2. If the foregoing adjustments do not suffice the requirements, the playback head shall be replaced.

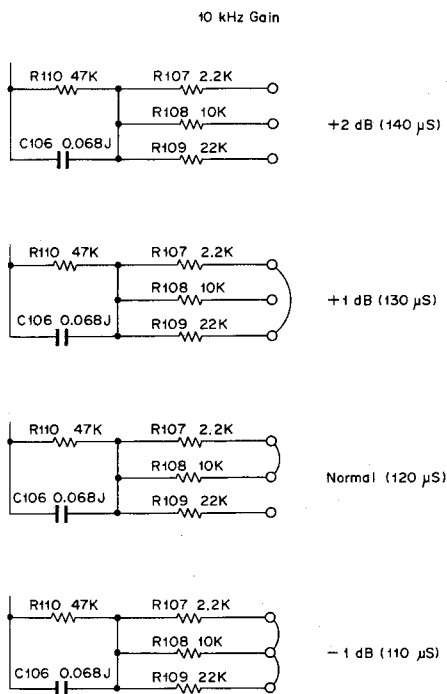

Fig. 7.18 Playback Equalizer Adjustment

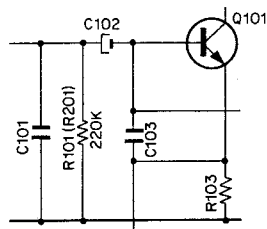

Fig. 7.19 PB Head Amp. Peaking Compensation

7.15.2. Overall Frequency Response

Signal Source

1 kHz 0.3 V to Line Input Jacks.

Measurement Connection

VTVM, Oscilloscope and Distortion Meter to Line Output Jacks.

Mode

MONITOR SW – SOURCE/TAPE

TAPE SELECTOR SW – EX (SX)

EQ SELECTOR SW – 120 μ s (70 μ s)

DOLBY NR SW – OUT

Adjustment

- (1) Set TAPE SELECTOR SW to SX and EQ SELECTOR SW to 70 μ s then load a Reference SX Tape (DA09025A).
- (2) Set to record/pause mode.
- (3) Set MONITOR SW to SOURCE and adjust line input level controls till the meters indicate 0 dB at 1 kHz 0.3 V input.
- (4) While in the above state, lower the output of the Generator by 30 dB.
- (5) Set MONITOR SW to TAPE then set to record/playback mode. Set the Generator to 15 kHz from 1 kHz and then adjust the azimuth alignment of the record head.
- (6) Adjustment shall be made on bias till the response at 10 kHz becomes 0 dB (\pm 1 dB).
- (7) Adjustment shall be made on peaking coils L151, 251 till the response at 20 kHz becomes 0 dB (\pm 2 dB).
- (8) Waving with a SX tape at 1 kHz – 20 kHz shall be not more than 3 dB.
- (9) Set TAPE SELECTOR SW to EX and EQ SELECTOR SW to 120 μ s, then load a Reference EXII Tape (DA09021A).
- (10) Set to record/playback mode, then adjust the azimuth alignment of record head.
- (11) Bias shall be adjusted till the response at 10 kHz becomes 0 dB (\pm 1 dB).
- (12) Measure the response at 20 kHz (\pm 2 dB).
- (13) Change the output of the Generator from –30 dB to –20 dB and check the frequency response.
- (14) Measure the distortion at 1 kHz 0 dB Overall.
SX/EXII – less than 1.5%
- (15) In case of excessive distortion, change the record head.

7.16. Signal-to-Noise Ratio Measurement

- (1) Connect a VTVM, Oscilloscope and Distortion Meter to Line Output Jacks, and then connect an Audio Generator to Line Input Jacks.
- (2) Set DOLBY NR switch to OUT.
- (3) Record and playback 400 Hz and adjust the line input level controls till the distortion becomes 3%.
- (4) Set DOLBY NR switch to IN at the recording level in (3) as above.
- (5) Disconnect the Generator from Line Input Jacks.
- (6) After rewind, playback once again and check the output difference between (4) and (5).

Note: The filter of IHF-A Curve shall be used in the measurement.

7.17. Channel Separation Measurement**7.17.1. Left Channel to Right Channel**

- (1) Connect a VTVM and Oscilloscope to Output Jacks, and connect an Audio Generator to Line Input Jack of L channel.
- (2) Set DOLBY NR switch to OUT.
- (3) Load a blank cassette tape.
- (4) Set MONITOR SW to SOURCE and adjust the L channel line input level control till the meter indicates 0 dB at 1 kHz. Set the R channel line input level control to maximum.
- (5) Set MONITOR SW to TAPE and record it.
- (6) After rewind, play it back.
- (7) Measure the difference between L and R channels.

7.17.2. Right Channel to Left Channel

- (1) Connect an Audio Generator to Line Input Jack of R channel.
- (2) Set MONITOR SW to SOURCE and adjust the R channel line input level control till the meter indicates 0 dB at 1 kHz.
- (3) The L channel line input level control shall be set to maximum.
- (4) Set MONITOR SW to TAPE and record it.
- (5) After rewind, play it back.
- (6) Measure the output difference between R and L channels.

7.18. Crosstalk Measurement

- (1) Connect a VTVM, Oscilloscope and 1 kHz Band Pass Filter to Output Jacks, and then connect an Audio Generator to Line Input Jacks.
- (2) Load a blank cassette tape.
- (3) Set MONITOR SW to SOURCE, and then adjust the line input level controls till the meters indicate 0 dB at 1 kHz.
- (4) Set MONITOR SW to TAPE and record it.
- (5) Turn the cassette tape the other way round and play it back, when measurement shall be made at 1 kHz Band Pass Filter.

- (6) Measure the output difference between (4) and (5) (R channel of A (or B) side to R channel of B (or A) side).

7.19. Erasure Measurement

- (1) Connect a VTVM and Oscilloscope to Output Jacks and connect an Audio Generator to Line Input Jacks.
- (2) Set MONITOR SW to SOURCE, and adjust the line input controls till the meters indicate 0 dB at 1 kHz.
- (3) Load a blank cassette tape.
- (4) Set MONITOR SW to TAPE and record it.
- (5) Then rewind it.
- (6) Disconnect the Audio Generator from the Line Input Jacks.
- (7) Record it once again (erase).
- (8) Then rewind.
- (9) Measure the output difference between (4) and (7).

7.20. Total Harmonic Distortion Measurement

- (1) Connect a Distortion Meter to Line Output Jacks, and connect an Audio Generator to Line Input Jacks.
- (2) Set to the following mode:
MONITOR SW – SOURCE/TAPE
TAPE SELECTOR SW – EX (SX)
EQ SELECTOR SW – 120 μ s (70 μ s)
DOLBY NR SW – OUT
OUTPUT LEVEL CONTROLS – Max.
- (3) Load a blank tape (EXII/SX).
- (4) Set MONITOR SW to SOURCE and adjust the line input level controls till the meters indicate 0 dB at 400 Hz.
- (5) Set MONITOR SW to TAPE and record then play it back.
- (6) Measure the reading of the Distortion Meter.

Note: Before the above measurement, record level calibration with 400 Hz Test Tone should be performed.

7.21. Wow/Flutter Measurement

- (1) Connect a Wow/Flutter Meter to Output Jack.
- (2) Load a 3 kHz Speed-Wow/Flutter Tape (DA09006A) and play it back.
- (3) Check the reading of Wow/Flutter Meter.

Note: DIN weighted peak shall be measured (playback only).

8. PARTS LOCATION FOR ELECTRICAL ADJUSTMENT

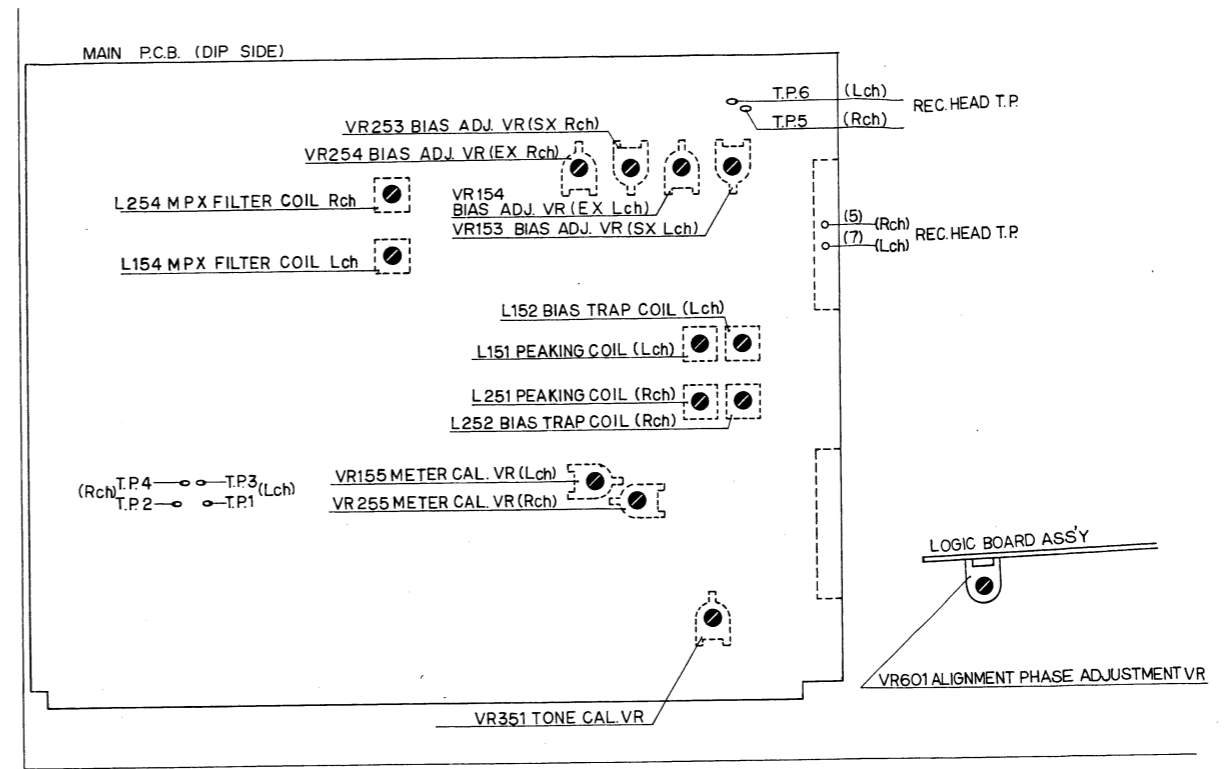

REAR VIEW

Fig. 8.1

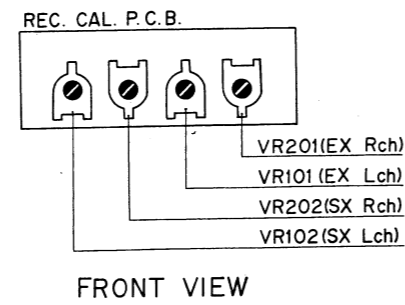

FRONT VIEW

Fig. 8.3

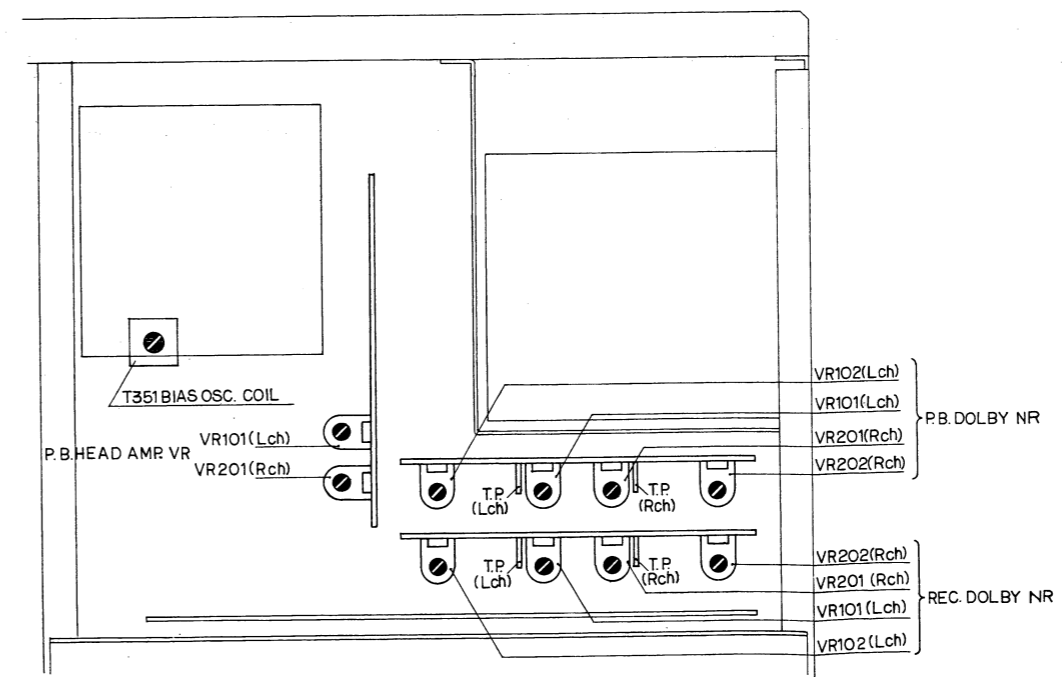

FRONT VIEW

Fig. 8.2

9. MOUNTING DIAGRAM AND PARTS LIST

Notes: 1. Mounting Diagram shows a dip side view of the printed circuit board.
 2. Diode FDH-999 is compatible with 1S1555.

9.1. Main P.C.B. Ass'y

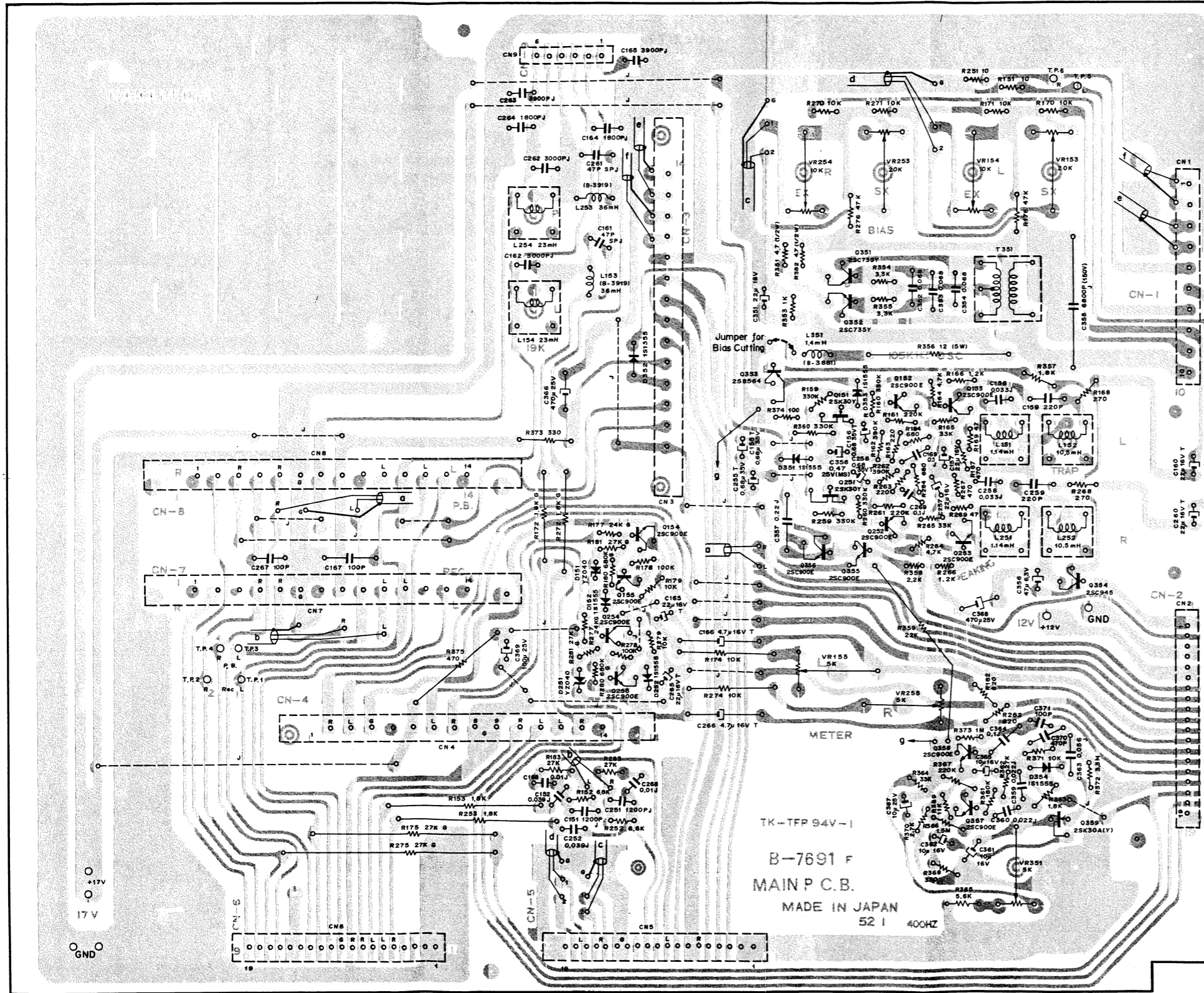

Fig. 9.1

Schematic Ref. No.	Part No.	Description	
	BA03799A	Main P.C.B. Ass'y	
		- Rec. Amp. -	
Q151, 251	OB01600A	FET	2SK30A(Y)
Q152, 153	OB01910A	Transistor	2SC900 (E)
252, 253			
355, 356			
D351, 352	OB01909A	Silicon Diode	1S1555
353			
L151, 251	OB03858A	Peaking Coil	1.14mH
L152, 252	OB03859A	Trap Coil	10.5mH
R159, 160	OB01921A	Carbon Resistor	330K ERD-25V J
259, 260			
360			
R161, 261	OB05596A	Carbon Resistor	220K ERD-25V J
R162, 262	OB05595A	Carbon Resistor	390K ERD-25V J
R163, 263	OB05608A	Carbon Resistor	220 ERD-25V J
R164, 264	OB01795A	Carbon Resistor	4.7K ERD-25V J
R165, 265	OB01879A	Carbon Resistor	33K ERD-25V J
R166, 266	OB05565A	Carbon Resistor	1.2K ERD-25V J
R167, 267	OB01792A	Carbon Resistor	470 ERD-25V J
R168, 268	OB05651A	Carbon Resistor	270 ERD-25V J
R169, 269	OB05569A	Carbon Resistor	47 ERD-25V J
R184, 284	OB05559A	Carbon Resistor	680 ERD-25V J
R358	OB05566A	Carbon Resistor	2.2K ERD-25V J
R359	OB05615A	Carbon Resistor	22K ERD-25T J
R374	OB05558A	Carbon Resistor	100 ERD-25V J
C155, 156	OB05773A	Tantalum Capacitor	0.68μ 35V
255, 256			
C157, 257	OB01862A	Electrolytic Capacitor	22μ 16V
C158, 258	OB05583A	Mylar Capacitor	0.033μ J
C159, 259	OB01289A	Ceramic Capacitor	220P 50V
C160, 260	OB05636A	Tantalum Capacitor	22μ 16V
C169, 269	OB01780A	Mylar Capacitor	0.1μ 50V J
C357	OB05584A	Mylar Capacitor	0.22μ 50V J
C358	OB01376A	Electrolytic Capacitor	0.47μ 25V
			M (MS)
C368	OB01401A	Electrolytic Capacitor	470μ 25V
		- 400Hz Osc. -	
Q357, 358	OB01910A	Transistor	2SC900 (E)
Q359	OB01600A	FET	2SK30A (Y)
D354	OB01909A	Silicon Diode	1S1555
VR351	OB01805A	Semi-fixed Volume	5K
R361	OB05669A	Carbon Resistor	180K ERD-25V J
R362	OB05538A	Carbon Resistor	27K ERD-25V J
R363	OB01830A	Carbon Resistor	1.8K ERD-25V J
R364	OB01879A	Carbon Resistor	33K ERD-25V J
R365	OB05673A	Carbon Resistor	5.6K ERD-25V J
R366	OB05601A	Carbon Resistor	1.5M ERD-25V J
R367	OB05596A	Carbon Resistor	220K ERD-25V J
R368	OB01789A	Carbon Resistor	330 ERD-25V J
R369	OB05826A	Carbon Resistor	11K ERD-25V J
R370	OB01782A	Carbon Resistor	2.7K ERD-25V J
R371	OB01833A	Carbon Resistor	10K ERD-25V J
R372	OB05775A	Carbon Resistor	3.3M ERD-25V J
R373	OB05564A	Carbon Resistor	1M ERD-25V J
C359, 360	OB05582A	Mylar Capacitor	0.022μ 50V J
C361, 362	OB01412A	Electrolytic Capacitor	10μ 16V
365			
C363	OB05813A	Mylar Capacitor	0.056μ 50V J
C364	OB01780A	Mylar Capacitor	0.1μ 50V J
C367	OB01674A	Electrolytic Capacitor	10μ 25V

Schematic Ref. No.	Part No.	Description	Schematic Ref. No.	Part No.	Description
C370	OB01716A	Ceramic Capacitor 470P 50V	C366	OB01401A	Electrolytic Capacitor 470μ 25V
C371	OB01288A	Ceramic Capacitor 100P 50V		BA03808A	19P Connector Ass'y (3 pcs.)
— Bias Osc. —				BA03809A	14P Connector Ass'y (4 pcs.)
Q351, 352	OB01338A	Transistor 2SC735 (Y)		BA03807A	10P Connector Ass'y (1 pce.)
Q353	OB06069A	Transistor 2SB564		OB03924A	Gate Pin (6 pcs.)
Q354	OB01872A	Transistor 2SC945 (L)		OB08001A	Tab (4 pcs.)
T351	OB06515A	Osc. Coil		OJ03186A	Level Control Stud (2 pcs.)
L351	OB03861A	Inductor 1.4mH		OJ03368B	Calibration Knob (1 pce.)
VR153, 253	OB01923A	Semi-fixed Volume 20K		OM03720A	Level Control Panel (1 pce.)
VR154, 254	OB01595A	Semi-fixed Volume 10K		OE00157A	Washer 3mm Collar (2 pcs.)
R151, 251	OB05663A	Carbon Resistor 10 ERD-25V J		OE00254A	Washer 3.1mm Mylar (1 pce.)
R170, 171	OB01833A	Carbon Resistor 10K ERD-25V J		OE00507A	Nut Hex. M3 (2 pcs.)
270, 271				OB08181A	6P-S Post (1 pce.)
R176, 276	OB05562A	Carbon Resistor 47K ERD-25V J		OE00655A	Screw M3x10 Philips Pan Head (Bronze) (2 pcs.)
R351, 352	OB05662A	Carbon Resistor 4.7 ERD-12V J		OT03648B	Bias Shield Plate (1 pce.)
R353	OB01781A	Carbon Resistor 1K ERD-25V J		OB05187A	Insulating Tube 1.2mm (2 pcs.)
R354, 355	OB01793A	Carbon Resistor 3.3K ERD-25V J		OE00037A	Earth lug B-5 (1 pce.)
R356	OB05761A	Cement Resistor 12 5W		OB07691F	Main P.C.B. 700
R357	OB01830A	Carbon Resistor 1.8K ERD-25V J			
C351	OB01862A	Electrolytic Capacitor 22μ 16V			
C352, 353	OB05586A	Mylar Capacitor 0.068μ 50V K			
354					
C355	OB05634A	S.P. Capacitor 6800P 150V J			
C356	OB01404A	Electrolytic Capacitor 47μ 6.3V			
— Meter Amp. —					
Q154, 155	OB01910A	Transistor 2SC900 (E)			
254, 255					
D151, 251	OB06063A	Zener Diode YZ040			
D152, 252	OB01909A	Silicon Diode 1S1555			
VR155, 255	OB01805A	Semi-fixed Volume 5K			
R174, 274	OB01888A	Carbon Resistor 10K ERD-25T J			
R177, 277	OB05863A	Metal Film Resistor 24K ERO-25CK G			
R178, 278	OB01920A	Carbon Resistor 100K ERD-25V J			
R179, 279	OB01833A	Carbon Resistor 10K ERD-25V J			
R180, 280	OB05822A	Metal Film Resistor 680K ERO-25VK G			
R181, 281	OB05901A	Metal Film Resistor 27K ERO-25CK G			
R182, 282	OB05511A	Carbon Resistor 820 ERD-25V J			
R375	OB05576A	Carbon Resistor 470 ERD-25T J			
C165, 265	OB05636A	Tantalum Capacitor 22μ 16V			
C166, 266	OB05657A	Tantalum Capacitor 4.7μ 16V			
C369	OB01272A	Electrolytic Capacitor 100μ 25V			
— Miscellaneous —					
L153, 253	OB03919A	Inductor 36mH			
L154, 254	OB03857A	19KHz Coil 23mH			
R152, 252	OB01877A	Carbon Resistor 6.8K ERD-25V J			
R153, 253	OB05614A	Carbon Resistor 1.8K ERD-25T J			
R172, 272	OB05900A	Metal Film Resistor 1.8K ERO-25CK G			
R175, 275	OB05901A	Metal Film Resistor 27K ERO-25CK G			
R183, 283	OB05538A	Carbon Resistor 27K ERD-25V J			
R373	OB05577A	Carbon Resistor 330 ERD-25T J			
C151, 251	OB05687A	Mylar Capacitor 1200P 50V J			
C152, 252	OB05660A	Mylar Capacitor 0.039μ 50V J			
C161, 261	OB05789A	S.P. Capacitor 47P 50V J			
C162, 262	OB01803A	Mylar Capacitor 3000P 50V J			
C163, 263	OB01804A	Mylar Capacitor 3900P 50V J			
C164, 264	OB01913A	Mylar Capacitor 1800P 50V J			
C167, 267	OB01288A	Ceramic Capacitor 100P 50V			
C168, 268	OB05681A	Mylar Capacitor 0.01μ 50V J			

9.2. Playback Dolby NR P.C.B. Ass'y

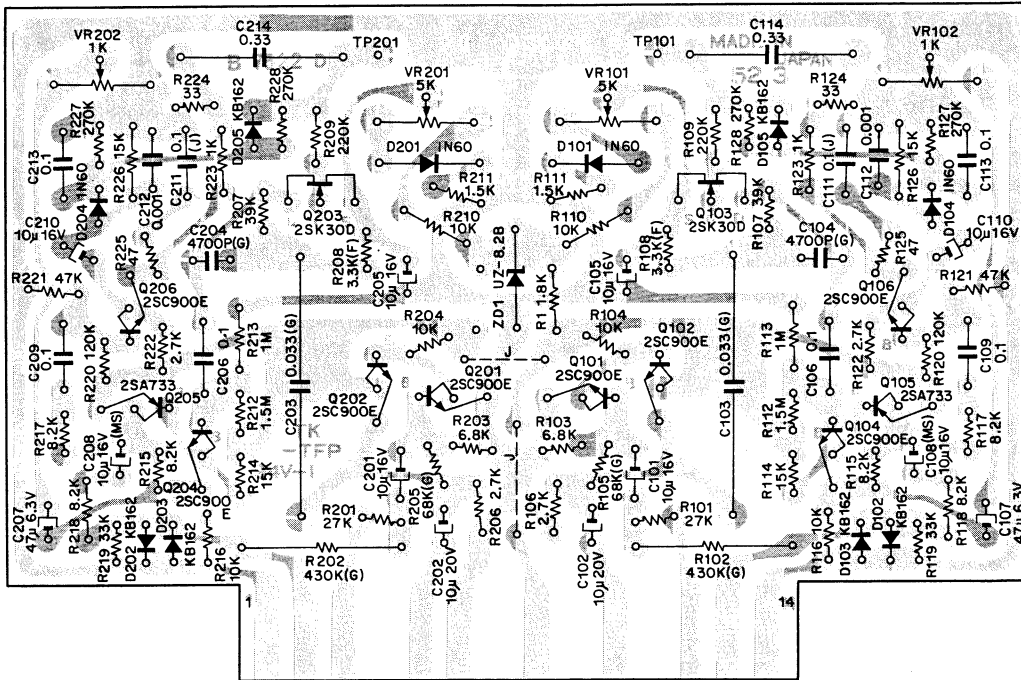

Fig. 9.2

Schematic Ref. No.	Part No.	Description	Schematic Ref. No.	Part No.	Description
	BA03588A	Playback Dolby NR P.C.B. Ass'y	R113,213	OB05564A	Carbon Resistor 1M ERD-25V J
	OB07522D	Playback Dolby NR P.C.B.	R114,126	OB05591A	Carbon Resistor 15K ERD-25V J
Q101,102	OB01910A	Transistor 2SC900 (E)	214,226		
104,106			R115,117	OB01878A	Carbon Resistor 8.2K ERD-25V J
201,202			118,215		
204,206			217,218		
Q103,203	OB06001A	FET 2SK30A (D)	R119,219	OB01879A	Carbon Resistor 33K ERD-25V J
Q105,205	OB06013A	Transistor 2SA733	R120,220	OB05568A	Carbon Resistor 120K ERD-25V J
OB01808B	OB01808B	Zener Diode UZ-8.2B	R121,221	OB05562A	Carbon Resistor 47K ERD-25V J
D101,104	OB00030A	Germanium Diode 1N60 (P)	R123,223	OB01781A	Carbon Resistor 1K ERD-25V J
201,204			R124,224	OB05567A	Carbon Resistor 33 ERD-25V J
D102,103	OB01599A	Silicon Varistor KB162	R125,225	OB05569A	Carbon Resistor 47 ERD-25V J
105,202			R127,128	OB05600A	Carbon Resistor 270K ERD-25V J
203,205					
VR101,201	OB01470A	Semi-fixed Volume 5K	C101,105	OB01412A	Electrolytic Capacitor 10μ 16V
VR102,202	OB01428A	Semi-fixed Volume 1K	110,201		
R1	OB01830A	Carbon Resistor 1.8K ERD-25V J	205,210		
R101,201	OB05538A	Carbon Resistor 27K ERD-25V J	C102,202	OB05581A	Tantalum Capacitor 10μ 20V
R102,202	OB05536A	Metal Film Resistor 430K ERO-25VK G	C103,203	OB01786A	P.P. Capacitor 0.033μ 50V G
R103,203	OB01877A	Carbon Resistor 6.8K ERD-25V J	C104,204	OB01608A	P.P. Capacitor 4700P 50V G
R104,110	OB01833A	Carbon Resistor 10K ERD-25V J	C106,109	OB01603A	Mylar Capacitor 0.1μ 50V K
116,204			113,206		
210,216			209,213		
R105,205	OB05535A	Metal Film Resistor 68K ERO-25VK G	C107,207	OB01404A	Electrolytic Capacitor 47μ 6.3V
R106,122	OB01782A	Carbon Resistor 2.7K ERD-25V J	C108,208	OB05840A	Electrolytic Capacitor 10μ 16VM (MS)
206,222			C111,211	OB01780A	Mylar Capacitor 0.1μ 50V J
R107,207	OB01885A	Carbon Resistor 39K ERD-25V J	C112,212	OB00091A	Mylar Capacitor 1000P 50V
R108,208	OB01585A	Metal Film Resistor 3.3K ERO-25VK F	C114,214	OB01602A	Mylar Capacitor 0.33μ 50V K
R109,209	OB05596A	Carbon Resistor 220K ERD-25V J	TP101,201	OB03924A	Gate Pin
R111,211	OB05505A	Carbon Resistor 1.5K ERD-25V J		OM03345B	Playback Dolby NR Indication Label (1 pce.)
R112,212	OB05601A	Carbon Resistor 1.5M ERD-25V J			

9.3. Record Dolby NR P.C.B. Ass'y

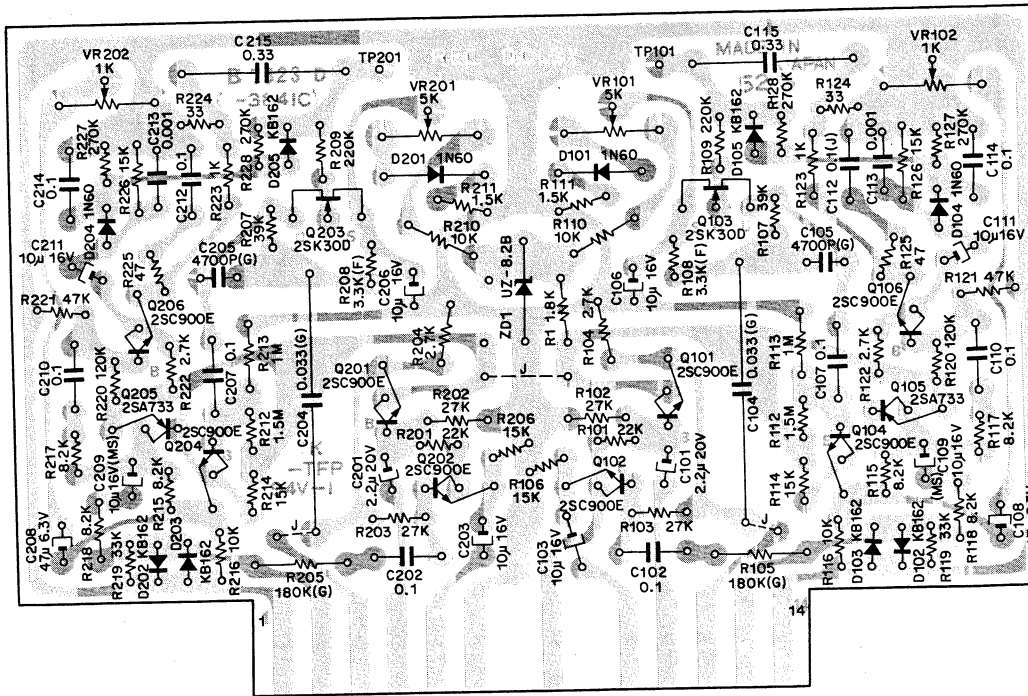

Fig. 9.3

Schematic Ref. No.	Part No.	Description	Schematic Ref. No.	Part No.	Description
	BA03589A	Record Dolby NR P.C.B. Ass'y	R111,211	0B05505A	Carbon Resistor 1.5K ERD-25V J
	0B07523D	Record Dolby NR P.C.B.	R112,212	0B05601A	Carbon Resistor 1.5M ERD-25V J
	0B01910A	Transistor 2SC900 (E)	R113,213	0B05564A	Carbon Resistor 1M ERD-25V J
Q101,102			R115,117	0B01878A	Carbon Resistor 8.2K ERD-25V J
104,106			118,215		
201,202			217,218		
204,206			R119,219	0B01879A	Carbon Resistor 33K ERD-25V J
Q103,203	0B06001A	FET 2SK30A (D)	R120,220	0B05568A	Carbon Resistor 120K ERD-25V J
Q105,205	0B06013A	Transistor 2SA733	R121,221	0B05562A	Carbon Resistor 47K ERD-25V J
ZD1	0B01808B	Zener Diode UZ-8.2B	R123,223	0B01781A	Carbon Resistor 1K ERD-25V J
D101,104	0B00030A	Germanium Diode 1N60 (P)	R124,224	0B05567A	Carbon Resistor 33 ERD-25V J
201,204			R125,225	0B05569A	Carbon Resistor 47 ERD-25V J
D102,103	0B01599A	Silicon Varistor KB162	R127,128	0B05600A	Carbon Resistor 270K ERD-25V J
105,202			227,228		
203,205			C101,201	0B05598A	Tantalum Capacitor 2.2μ 20V
VR101,201	0B01470A	Semi-fixed Volume 5K	C102,107	0B01603A	Mylar Capacitor 0.1μ 50V K
VR102,202	0B01428A	Semi-fixed Volume 1K	110,114		
R1	0B01830A	Carbon Resistor 1.8K ERD-25V J	202,207		
R101,201	0B05661A	Carbon Resistor 22K ERD-25V J	210,214		
R102,103	0B05538A	Carbon Resistor 27K ERD-25V J	C103,106	0B01412A	Electrolytic Capacitor 10μ 16V
202,203			111,203		
R104,122	0B01782A	Carbon Resistor 2.7K ERD-25V J	206,211		
204,222			C104,204	0B01786A	P.P. Capacitor 0.033μ 50V G
R105,205	0B01590A	Metal Film Resistor 180K ERO-25VK G	C105,205	0B01608A	P.P. Capacitor 4700P 50V G
R106,114	0B05591A	Carbon Resistor 15K ERD-25V J	C108,208	0B01404A	Electrolytic Capacitor 47μ 6.3V
126,206			C109,209	0B05840A	Electrolytic Capacitor 10μ 16V M (MS)
214,226			C112,212	0B01780A	Mylar Capacitor 0.1μ 50V J
R107,207	0B01885A	Carbon Resistor 39K ERD-25V J	C113,213	0B00091A	Mylar Capacitor 1000P 50V
R108,208	0B01585A	Metal Film Resistor 3.3K ERO-25VK F	C115,215	0B01602A	Mylar Capacitor 0.33μ 50V K
R109,209	0B05596A	Carbon Resistor 220K ERD-25V J	TP101,201	0B03924B	Gate Pin
R110,116	0B01833A	Carbon Resistor 10K ERD-25V J		0M03346B	Record Dolby NR Indication Label (1 p.c.e.)
210,216					

9.4. Playback Head Amp. P.C.B. Ass'y

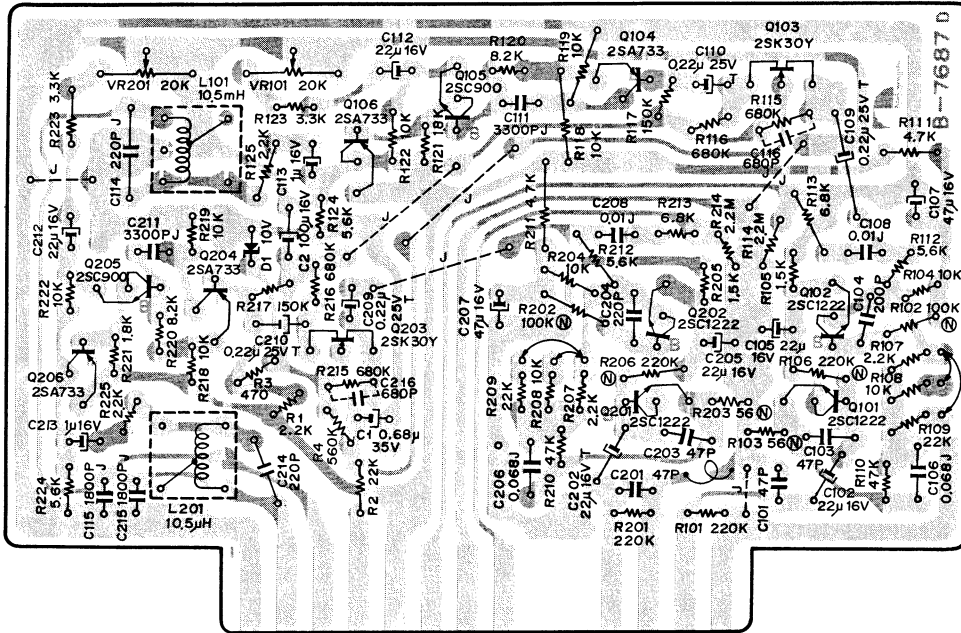

Fig. 9.4

Schematic Ref. No.	Part No.	Description	Schematic Ref. No.	Part No.	Description
	BA03802A	Playback Head Amp. P.C.B. Ass'y	R112,124	OB05673A	Carbon Resistor 5.6K ERD-25V J
			212,224		
			R113,213	OB01877A	Carbon Resistor 6.8K ERD-25V J
Q101,102	OB07687D	Playback Head Amp. P.C.B.	R114,214	OB05672A	Carbon Resistor 2.2M ERD-25V J
201,202	OB06062A	Transistor 2SC1222 (2)	R115,116	OB05597A	Carbon Resistor 680K ERD-25V J
Q103,203	OB01600A	FET 2SK30 (Y)	215,216		
Q104,106	OB06013A	Transistor 2SA733	R117,217	OB05593A	Carbon Resistor 150K ERD-25V J
204,206			R120,220	OB01878A	Carbon Resistor 8.2K ERD-25V J
Q105,205	OB01910A	Transistor 2SC900 (E)	R121,221	OB01830A	Carbon Resistor 1.8K ERD-25V J
D1	OB06116A	Zener Diode UZ-10B	R123,223	OB01793A	Carbon Resistor 3.3K ERD-25V J
L101,201	OB00068A	Trap Coil 10.5mH	C1	OB05773A	Tantalum Capacitor 0.68µ 35V
VR101,201	OB01922A	Semi-fixed Volume 20K	C2	OB01400A	Electrolytic Capacitor 100µ 16V
R1	OB05566A	Carbon Resistor 2.2K ERD-25V J	C101,103	OB01456A	Ceramic Capacitor 47P 50V
107,125			201,203		
207,225			C102,202	OB05636A	Tantalum Capacitor 22µ 16V
R2	OB05661A	Carbon Resistor 22K ERD-25V J	C104,204	OB01289A	Ceramic Capacitor 220P 50V
109,209			C105,112	OB01862A	Electrolytic Capacitor 22µ 16V
R3	OB01792A	Carbon Resistor 470 ERD-25V J	205,212		
R4	OB05665A	Carbon Resistor 560K ERD-25V J	C106,206	OB05682A	Mylar Capacitor 0.068µ 50V J
R101,201	OB05596A	Carbon Resistor 220K ERD-25V J	C107,207	OB01403A	Electrolytic Capacitor 47µ 16V
R102,202	OB01931A	Carbon Resistor 100K ERD-14VS J	C108,208	OB05681A	Mylar Capacitor 0.01µ 50V J
		(Noiseless)	C109,110	OB05772A	Tantalum Capacitor 0.22µ 25V
R103,203	OB05642A	Carbon Resistor 56 ERD-14VS J	209,210		
		(Noiseless)	C111,211	OB01914A	Mylar Capacitor 3300P 50V J
R104,108	OB01833A	Carbon Resistor 10K ERD-25V J	C113,213	OB01405A	Electrolytic Capacitor 1µ 16V
118,119			C114,214	OB05532A	S.P. Capacitor 220P 50V J
122,204			C115,215	OB01913A	Mylar Capacitor 1800P 50V J
208,218			C116,216	OT04027A	Ceramic Capacitor 680P 50V
219,222			OM03713A	Playback Head Amp. Label B (1 pce.)	
R105,205	OB05505A	Carbon Resistor 1.5K ERD-25V J	OB08084A	PB Head Amp. Shield Plate (1 pce.)	
R106,206	OB05517A	Carbon Resistor 220K ERD-14VS J	OB08085A	PB Head Amp. Shield Plate Insulator (1 pce.)	
		(Noiseless)			
R110,210	OB05562A	Carbon Resistor 47K ERD-25V J			
R111,211	OB01795A	Carbon Resistor 4.7K ERD-25V J			

9.5. Switch P.C.B. Ass'y

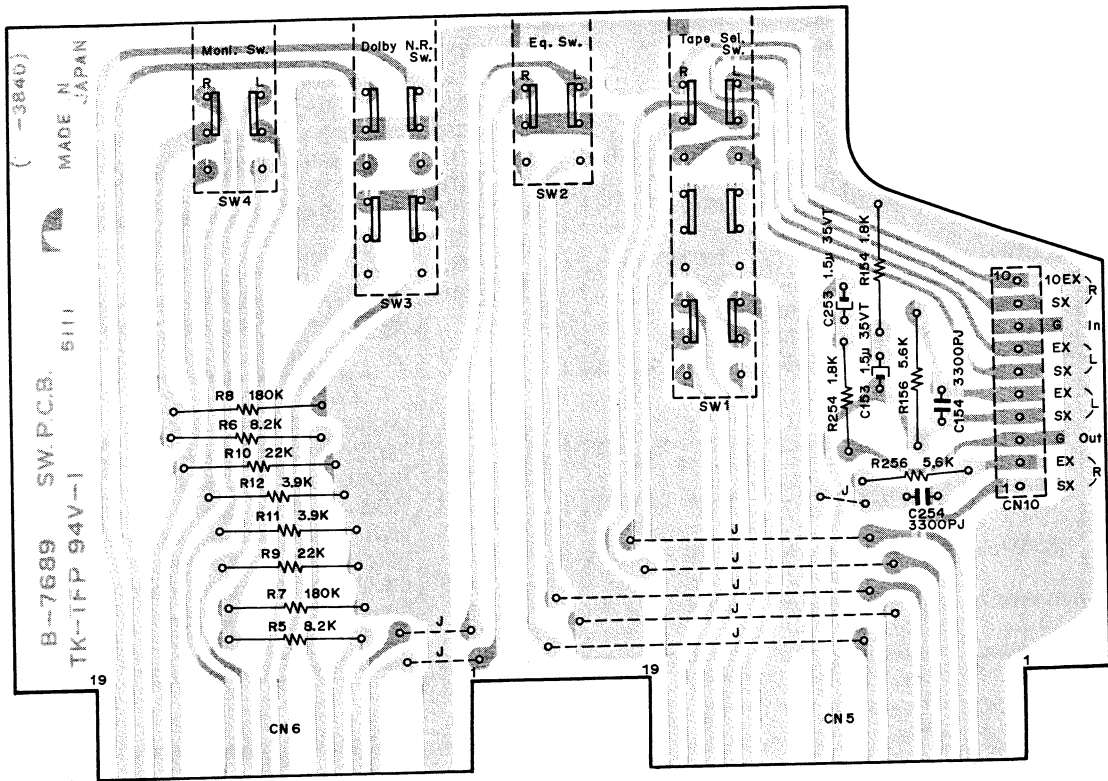

Fig. 9.5

Schematic Ref. No.	Part No.	Description
	BA03798A	Switch P.C.B. Ass'y
	0B07689D	Switch P.C.B.
R5, 6	0B01856A	Carbon Resistor 8.2K ERD-25T J
R7, 8	0B05640A	Carbon Resistor 180K ERD-25T J
R9, 10	0B05615A	Carbon Resistor 22K ERD-25T J
R11, 12	0B05675A	Carbon Resistor 3.9K ERD-25T J
R154, 254	0B05614A	Carbon Resistor 1.8K ERD-25T J
R156, 256	0B01887A	Carbon Resistor 5.6K ERD-25T J
C153, 253	0B05639A	Tantalum Capacitor 1.5μ 35V
C154, 254	0B01914A	Mylar Capacitor 3300P 50V J
	0B07164A	Push Switch 700 6242 (1 pce.)
	0B08286A	10P-S Post (1 pce.)

Schematic Ref. No.	Part No.	Description	Schematic Ref. No.	Part No.	Description
	BA03797A	Front Control P.C.B. Ass'y	R737, 837	OB01564A	Carbon Resistor 82K ERD-25V J
			R738, 838	OB05569A	Carbon Resistor 47 ERD-25V J
			R739, 839	OB01879A	Carbon Resistor 33K ERD-25V J
			R740, 840	OB05566A	Carbon Resistor 2.2K ERD-25V J
			C712, 715	OB01405A	Electrolytic Capacitor 1 μ 16V
			812, 815		
Q701, 801	OB06062A	Transistor 2SC1222 (2)	C713, 714	OB01389A	Electrolytic Capacitor 4.7 μ 16V
901			719, 813		
Q702, 802	OB06013A	Transistor 2SA733	814, 819		
902			C716, 816	OB01412A	Electrolytic Capacitor 10 μ 16V
Q703, 803	OB01872A	Transistor 2SC945 (L)	C924	OB01401A	Electrolytic Capacitor 470 μ 25V
903					
VR2	OB07134A	Volume 10K (C) x 2			
VR3	OB07135A	Volume 10K (C)			
R701, 703	OB01833A	Carbon Resistor 10K ERD-25V J			
801, 803					
901, 903					
R702, 802	OB05558A	Carbon Resistor 100 ERD-25V J	Q711, 811	OB06013A	Transistor 2SA733
902			Q712, 812	OB01872A	Transistor 2SC945 (L)
R704, 804	OB05665A	Carbon Resistor 560K ERD-25V J	Q713, 813	OB06066A	Transistor 2SD471
904			Q714, 814	OB06069A	Transistor 2SB564
R705, 805	OB05564A	Carbon Resistor 1M ERD-25V J	D701, 801	OB01702A	Silicon Varistor KB269
905			R741, 841	OB01877A	Carbon Resistor 6.8K ERD-25V J
R706, 806	OB05669A	Carbon Resistor 180K ERD-25V J	R742, 842	OB05511A	Carbon Resistor 820 ERD-25V J
906			R743, 843	OB05591A	Carbon Resistor 15K ERD-25V J
R707, 807	OB01878A	Carbon Resistor 8.2K ERD-25V J	R744, 844	OB01788A	Carbon Resistor 68 ERD-25V J
907			R745, 746	OB05663A	Carbon Resistor 10 ERD-25V J
R708, 808	OB05606A	Carbon Resistor 22 ERD-25V J	845, 846		
908			923		
R709, 809	OB05661A	Carbon Resistor 22K ERD-25V J	R747, 847	OB05563A	Carbon Resistor 56K ERD-25V J
909			R748, 848	OB01795A	Carbon Resistor 4.7K ERD-25V J
R710, 810	OB05608A	Carbon Resistor 220 ERD-25V J	R749, 849	OB05565A	Carbon Resistor 1.2K ERD-25V J
910			C717, 817	OB01412A	Electrolytic Capacitor 10 μ 16V
R711, 811	OB01885A	Carbon Resistor 39K ERD-25V J	C718, 818	OB01400A	Electrolytic Capacitor 100 μ 16V
911			C923	OB01401A	Electrolytic Capacitor 470 μ 25V
R712, 812	OB05664A	Carbon Resistor 3.9K ERD-25V J			
912					
R713, 813	OB05673A	Carbon Resistor 5.6K ERD-25V J	Q704, 705	OB06062A	Transistor 2SC1222 (2)
R913	OB01795A	Carbon Resistor 4.7K ERD-25V J	804, 805		
C701, 702	OB01412A	Electrolytic Capacitor 10 μ 16V	Q706, 806	OB06013A	Transistor 2SA733
705, 801			VR1	OB07136A	Volume 100K (A)
802, 805			R714, 715	OB05895A	Metal Film Resistor 10K ERO-25VK G
901, 902			721, 814		
905			815, 821		
C703, 803	OB01288A	Ceramic Capacitor 100P 50V	R716, 816	OB05558A	Carbon Resistor 100 ERD-25V J
903			R717, 719	OB01920A	Carbon Resistor 100K ERD-25V J
C704, 804	OB05899A	Electrolytic Capacitor 220 μ 10V	817, 819		
904			R718, R818	OB01902A	Carbon Resistor 68K ERD-25V J
C922	OB01272A	Electrolytic Capacitor 100 μ 25V	R720, 726	OB05673A	Carbon Resistor 5.6K ERD-25V J
			820, 826		
			R722, 822	OB05700A	Carbon Resistor 470K ERD-25V J
			R723, 823	OB05669A	Carbon Resistor 180K ERD-25V J
			R724, 824	OB05561A	Carbon Resistor 18K ERD-25V J
			R725, 825	OB05538A	Carbon Resistor 27K ERD-25V J
			R727, 827	OB05688A	Carbon Resistor 390 ERD-25V J
			R750, 850	OB01879A	Carbon Resistor 33K ERD-25V J
			R921	OB01704A	Carbon Resistor 68 ERD-25T J
			R922	OB05649A	Carbon Resistor 150 ERD-25V J
Q707, 709	OB06062A	Transistor 2SC1222 (2)	C706, 707	OB01412A	Electrolytic Capacitor 10 μ 16V
710, 807			708, 709		
809, 810			710, 806		
Q708, 808	OB06013A	Transistor 2SA733	807, 808		
VR4	OB07027A	Volume 10K (B) x 2	809, 810		
R728, 828	OB05674A	Carbon Resistor 820K ERD-25V J	C711, 811	OB05667A	Tantalum Capacitor 10 μ 16V
R729, 829	OB01920A	Carbon Resistor 100K ERD-25V J	C921	OB01401A	Electrolytic Capacitor 470 μ 25V
R731, 735	OB05558A	Carbon Resistor 100 ERD-25V J		OB07690B	Front Control P.C.B.
831, 835					
R732, 832	OB05664A	Carbon Resistor 3.9K ERD-25V J			
R733, 833	OB05649A	Carbon Resistor 150 ERD-25V J			
R734, 834	OB05505A	Carbon Resistor 1.5K ERD-25V J			
R736, 836	OB05562A	Carbon Resistor 47K ERD-25V J			

9.6. Front Control P.C.B. Ass'y

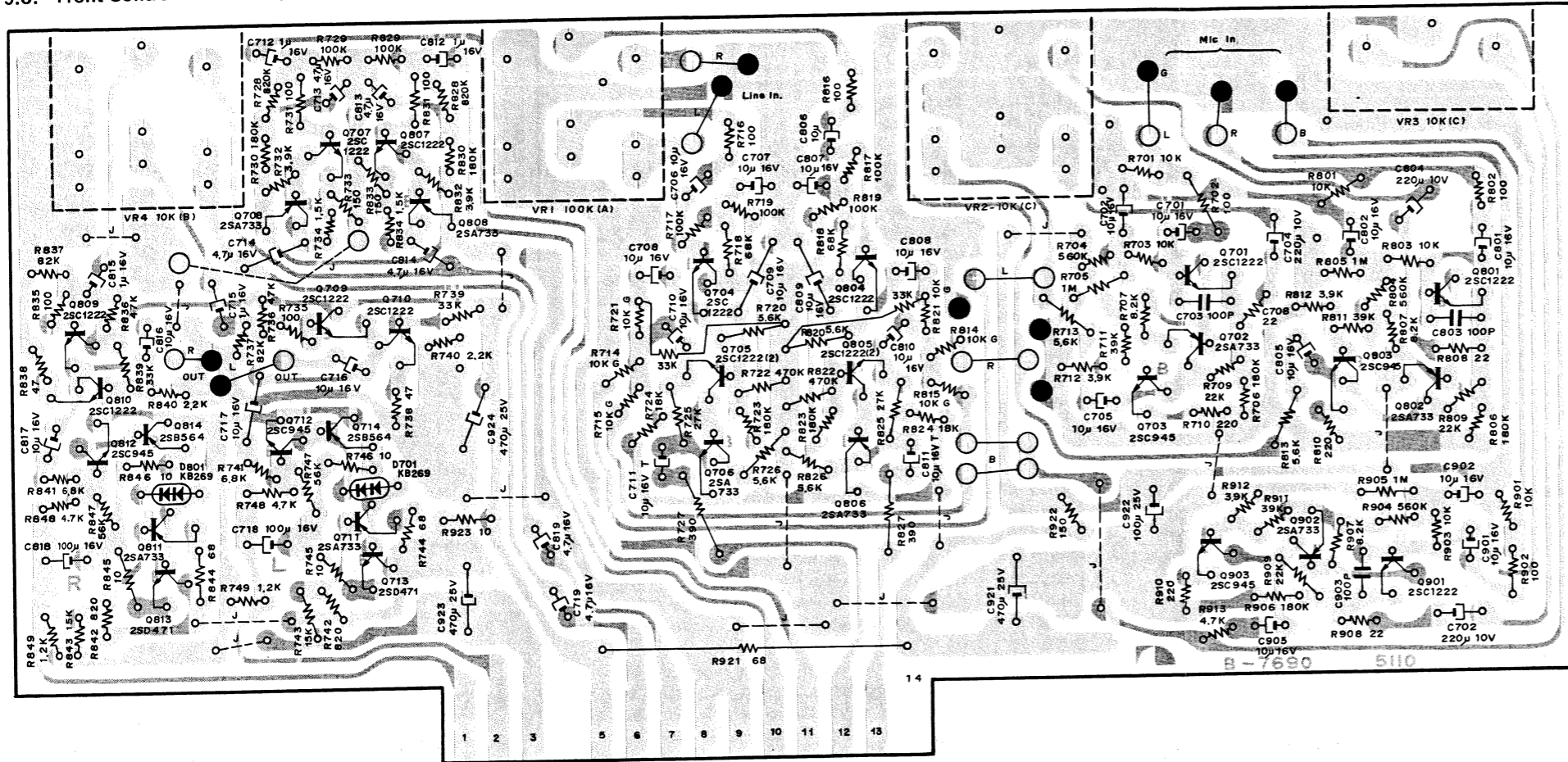

Fig. 9.6

9.7. DIN Amp. P.C.B. Ass'y

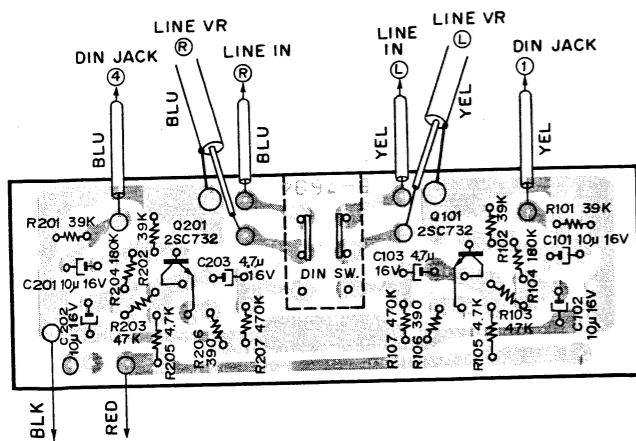

Fig. 9.7

9.8. Record Cal. P.C.B. Ass'y

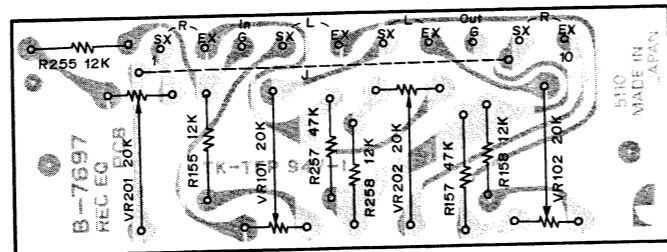

Fig. 9.8

Schematic Ref. No.	Part No.	Description
	BA03810A	DIN Amp. P.C.B. Ass'y
Q101, 201	0B07694D	DIN Amp. P.C.B. Transistor 2SC900 (E)
R101, 102	0B01910A	Carbon Resistor 39K ERD-25V J
201, 202	0B01885A	Carbon Resistor 39K ERD-25V J
R103, 203	0B05562A	Carbon Resistor 47K ERD-25V J
R104, 204	0B05669A	Carbon Resistor 180K ERD-25V J
R105, 205	0B01795A	Carbon Resistor 4.7K ERD-25V J
R106, 206	0B05688A	Carbon Resistor 390 ERD-25V J
R107, 207	0B05700A	Carbon Resistor 470K ERD-25V J
C101, 102	0B01412A	Electrolytic Capacitor 10μ 16V
201, 202	0B01412A	Electrolytic Capacitor 10μ 16V
C103, 203	0B01389A	Electrolytic Capacitor 4.7μ 16V
	BA03815A	Record Cal. P.C.B. Ass'y
VR101, 102	0B07697B	Record Cal. P.C.B. Semi-fixed Volume 20K
201, 202	0B07150A	Semi-fixed Volume 20K
R155, 158	0B05771A	Carbon Resistor 12K ERD-25T J
255, 258	0B05641A	Carbon Resistor 47K ERD-25T J
R157, 257	0B08287A	10P-H Connector Ass'y (1 pce.)

9.9. Capstan Motor Governor P.C.B. Ass'y

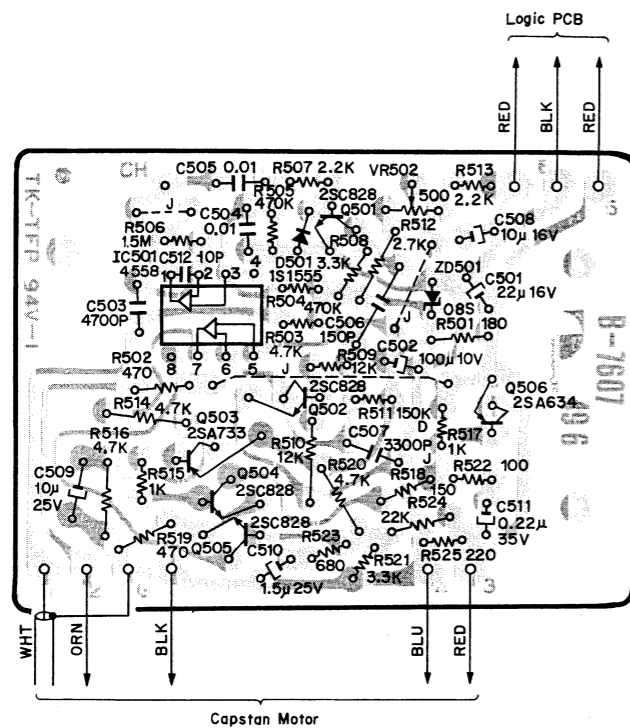

Fig. 9.9

9.10. Reel Motor Governor P.C.B. Ass'y

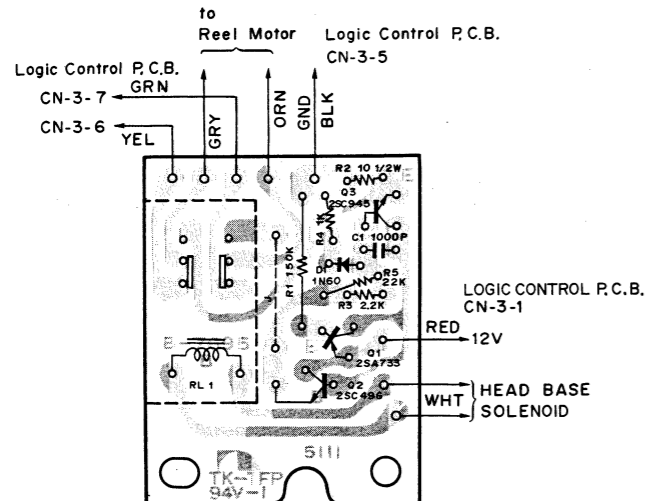

Fig. 9.10

9.11. Shut-off Sensor P.C.B. Ass'y and Shut-off Luminous P.C.B. Ass'y

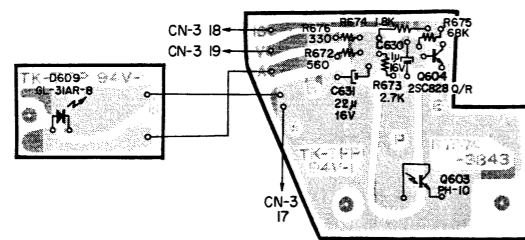

Fig. 9.11

Schematic Ref. No.	Part No.	Description	Schematic Ref. No.	Part No.	Description
	BA03662B	Capstan Motor Governor P.C.B. Ass'y		BA03813A	Reel Motor Governor P.C.B. Ass'y
	0B07607C	Capstan Motor Governor P.C.B.		0B07695B	Reel Motor Governor P.C.B.
IC501	0B06124B	IC 4558	Q1	0B06013A	Transistor 2SA733
Q501,502	0B01824A	Transistor 2SC828	Q2	0B01790A	Transistor 2SC496
504,505			Q3	0B01872A	Transistor 2SC945
Q503	0B06013A	Transistor 2SA733	D1	0B00030A	Germanium Diode 1N60 (P)
Q506	0B06012A	Transistor 2SA634	R1	0B05593A	Carbon Resistor 150K ERD-25V J
D501	0B01909A	Silicon Diode 1S1555	R2	0B05913A	Carbon Resistor 10 1/2W
ZD501	0B06004A	Zener Diode 08S	R3	0B05566A	Carbon Resistor 2.2K ERD-25V J
VR502	0B01883A	Semi-fixed Volume 500Ω	R4	0B01781A	Carbon Resistor 1K ERD-25V J
R501	0B05607A	Carbon Resistor 180 ERD-25V J	R5	0B05661A	Carbon Resistor 22K ERD-25V J
R502,519	0B01792A	Carbon Resistor 470 ERD-25V J	C1	0B04059A	Mylar Capacitor 1000P 50V K
R503,514	0B01795A	Carbon Resistor 4.7K ERD-25V J	RL1	0B07149A	Relay DC12V MIS2
R504,505	0B05700A	Carbon Resistor 470K ERD-25V J	0J03583B	Governor Heat Sink (1 pce.)	
R506	0B05601A	Carbon Resistor 1.5M ERD-25V J	0E00121A	Screw M2.6 x 6 Philips Pan Head (1 pce.)	
R507,513	0B05566A	Carbon Resistor 2.2K ERD-25V J	0E00026A	Washer 2.6mm Spring (1 pce.)	
R508,521	0B01793A	Carbon Resistor 3.3K ERD-25V J	0E00142A	Washer 2.6mm (1 pce.)	
R509,510	0B05650A	Carbon Resistor 12K ERD-25V J	0E00612A	Screw M3 x 6 Philips Pan Head (2A)	
R511	0B05628A	Metal Film Resistor 150K ER0-25VK D			
R512	0B01782A	Carbon Resistor 2.7K ERD-25V J			
R515,517	0B01781A	Carbon Resistor 1K ERD-25V J			
R518	0B05649A	Carbon Resistor 150 ERD-25V J			
R522	0B05558A	Carbon Resistor 100 ERD-25V J			
R523	0B05559A	Carbon Resistor 680 ERD-25V J			
R524	0B05661A	Carbon Resistor 22K ERD-25V J			
R525	0B05608A	Carbon Resistor 220 ERD-25V J			
C501	0B01862A	Electrolytic Capacitor 22μ 16V			
C502	0B05885A	Electrolytic Capacitor 100μ 10V			
C503	0B01915A	Mylar Capacitor 4700P 50V			
C504,505	0B01609A	Mylar Capacitor 0.01μ 50V K			
C506	0B05599A	Ceramic Capacitor 150P 50V			
C507	0B05552A	S.P. Capacitor 3300P 100V J			
C508	0B01412A	Electrolytic Capacitor 10μ 16V			
C509	0B05581A	Tantalum Capacitor 10μ 25V			
C510	0B05639A	Tantalum Capacitor 1.5μ 25V			
C511	0B05772A	Tantalum Capacitor 0.22μ 35V			
C512	0B05798A	Ceramic Capacitor 10P 50V K			
0B08069C	Heat Sink (1 pce.)		D609	0B07575C	Shut-off Luminous P.C.B.
0B08077B	Capstan Motor Governor P.C.B. Holder (1 pce.)		0B06039A	LED GL-31AR-8	
0E00071A	Fiber Washer 3mm (2 pcs.)				
0E00507A	Nut Hex. M3 (1 pce.)				
0E00510A	Screw M3 x 8 Philips Pan Head (2A) (2 pcs.)				
0E00597A	Washer 3mm 3 x 8 x 0.5 (1 pce.)				
0E00608A	Screw M3 x 10 Philips Pan Head (3A) (1 pce.)				
0E00606A	Screw M 3 x 6 Philips Pan Head (3A) (1 pce.)				

9.12. 400 Hz Osc. Switch P.C.B. Ass'y

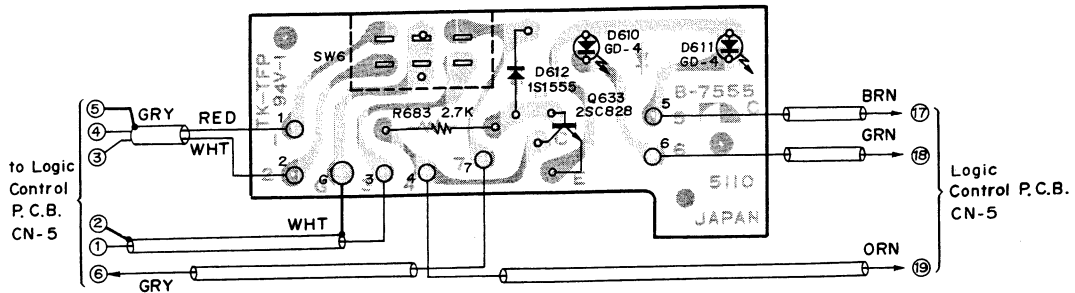

Fig. 9.12

9.13. Head Base Switch P.C.B. Ass'y

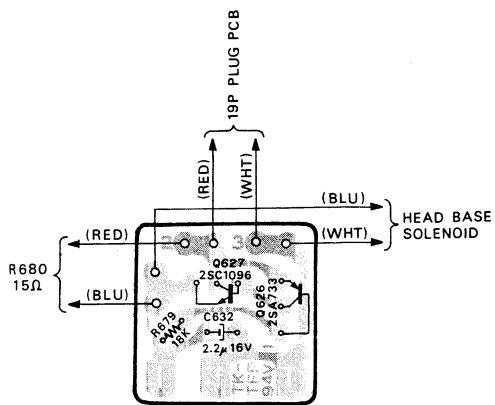

Fig. 9.13

9.14. Brake Solenoid P.C.B. Ass'y

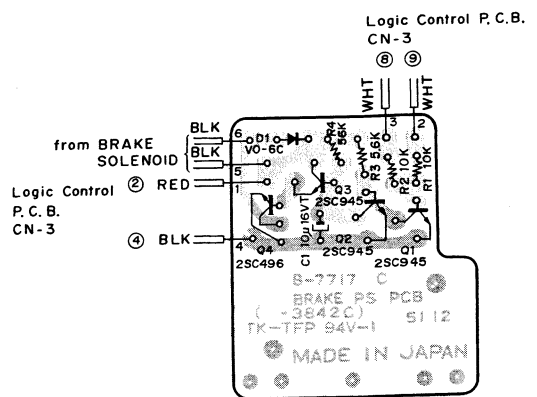

Fig. 9.14

Schematic Ref. No.	Part No.	Description	Schematic Ref. No.	Part No.	Description
	BA03678B	400 Hz Osc. Switch P.C.B. Ass'y		BA03836A	Brake Solenoid P.C.B. Ass'y
Q633	OB07555C	Osc. Switch P.C.B.	Q1,2,3	OB07717C	Brake Solenoid P.C.B.
D610, 611	OB01824A	Transistor 2SC828	Q4	OB01872A	Transistor 2SC945 (L)
D612	OB06028A	LED GD42035RD	D1	OB01790A	Transistor 2SC496
R683	OB01909A	Silicon Diode 1S1555	R1,2	OB01501U	Silicon Diode V0-6C
	OB05629A	Carbon Resistor 2.7K ERD-25T J	R3	OB01833A	Carbon Resistor 10K ERD-25V J
	OB07029A	Slide Switch (1 pce.)	R4	OB05673A	Carbon Resistor 5.6K ERD-25V J
	OC05422A	Switch Cover (1 pce.)	C1	OB05563A	Carbon Resistor 56K ERD-25V J
	BA03666A	Head Base Switch P.C.B. Ass'y		OB05667A	Tantalum Capacitor 10μ 16V
Q626	OB07578B	Head Base Switch Sub P.C.B.			
Q627	OB06013A	Transistor 2SA733			
R679	OB01895A	Transistor 2SC1096			
C632	OB05561A	Carbon Resistor 18K ERD-25V J			
	OB05512A	Electrolytic Capacitor 2.2μ 16V			

Schematic Ref. No.	Part No.	Description	Schematic Ref. No.	Part No.	Description
	BA03953A	Logic Control P.C.B. Ass'y	R652,653 654,655 656,658 659,663 665,667	OB01781A	Carbon Resistor 1K ERD-25V J
L601,603 605	OB07593B	Logic Control P.C.B.	R660	OB01679A	Carbon Resistor 100 ERD-25T J
L602,606	OB06041B	IC N7400A	R668	OB01877A	Carbon Resistor 6.8K ERD-25V J
L604	OB06042B	IC N7410A	R679	OB05663A	Carbon Resistor 10 ERD-25V J
L607	OB06043C	IC N7420A	C601,602	OB05657A	Tantalum Capacitor 4.7μ 16V
L608	OB06044C	IC N7474A	C603,604	OB01288A	Ceramic Capacitor 100P 50V
Q601,602	OB06027A	IC RC4709	C605,606	OB05745A	Ceramic Capacitor 3P 50V
605,606	OB01824A	Transistor 2SC828	C607,608	OB05581A	Tantalum Capacitor 10μ 20V
608,611			C609	OB01411A	Electrolytic Capacitor 100μ 6.3V
612,613			C610	OB01405A	Electrolytic Capacitor 1μ 16V
616,618			C611	OB01772A	Mylar Capacitor 0.12μ 50V K
622,626			C612	OB01392A	Electrolytic Capacitor 470μ 16V
629,630			C613	OB01400A	Electrolytic Capacitor 100μ 16V
Q607,609	OB06013A	Transistor 2SA733	C614, 618 624	OB01412A	Electrolytic Capacitor 10μ 16V
Q610,614	OB06020A	Transistor 2SC1096	C615, 622 625	OB05949A	Tantalum Capacitor 0.33μ 35V
Q615,617 619	OB01910A	Transistor 2SC900	C616, 619	OB01404A	Electrolytic Capacitor 47μ 6.3V
Q620,621 623,624 625	OB01338A	Transistor 2SC735	C617	OB01609A	Mylar Capacitor 0.01μ 50V K
D601,602 603	OB01501U	Silicon Diode V06C	C620, 621 629	OB01862A	Electrolytic Capacitor 22μ 16V
D604,605	OB00030A	Germanium Diode 1N60 (P)	C623	OB05781A	Tantalum Capacitor 0.1μ 35V
D606,607	OB01909A	Silicon Diode 1S1555	C626, 628	OB05638A	Tantalum Capacitor 1μ 35V
D608	OB01599A	Silicon Varistor KB162	C632, 633	OB01603A	Mylar Capacitor 0.1μ 50V K
ZD601	OB06014A	Zener Diode 06R	C634, 635	OB05530A	Mylar Capacitor 6800P 50V K
VR601	OB07058A	Semi-fixed Volume 50K	C636, 637	OB01456A	Ceramic Capacitor 47P 50V
R601,602	OB01920A	Carbon Resistor 100K ERD-25V J	RL601,602	OB07001A	Relay LC1-C
R603,604 641,649 664,666	OB01833A	Carbon Resistor 10K ERD-25V J		OB03067A	Wiring Holder (2 pcs.)
R605,606 657	OB05566A	Carbon Resistor 2.2K ERD-25V J		OB08001A	Tab (3 pcs.)
R607,608	OB05596A	Carbon Resistor 220K ERD-25V J		OB07535D	19P Plug Board (D) (1 pce.)
R609,610	OB05591A	Carbon Resistor 15K ERD-25V J		OB07629B	19P Plug Board (1 pce.)
R611,612 621,625 632,633 636,678	OB01795A	Carbon Resistor 4.7K ERD-25V J		0E00174A	Earth Lug B-4 (1 pce.)
R613,614	OB05505A	Carbon Resistor 1.5K ERD-25V J		0E00607A	Screw M3 x 8 Philips Pan Head (3A) (3 pcs.)
R615,616	OB05577A	Carbon Resistor 330 ERD-25T J		BA03808A	19P Connector Ass'y (3 pcs.)
R620,623 624,645	OB05661A	Carbon Resistor 22K ERD-25V J		0C05157C	P.C.B. Holder A (2 pcs.)
R622	OB05670A	Carbon Resistor 1.8M ERD-25V J		0E00507A	Nut Hex. M3 (4 pcs.)
R626,629	OB05678A	Carbon Resistor 560 ERD-25V J		0E00518A	Screw M 3 x 8 Philips Flat Head (1 pce.)
R627	OB05565A	Carbon Resistor 1.2K ERD-25V J		0E00581A	Washer 3mm Spring (1 pce.)
R628, 643 651,681 682	OB05673A	Carbon Resistor 5.6K ERD-25V J		OB05110A	HP Separate Plug Cord (1 pce.)
R630,662 669	OB05562A	Carbon Resistor 47K ERD-25V J			
R631,642 650	OB05563A	Carbon Resistor 56K ERD-25V J			
R634	OB01830A	Carbon Resistor 1.8K ERD-25V J			
R635,638 648	OB01933A	Carbon Resistor 220 ERD-25T J			
R637	OB05572A	Carbon Resistor 470 ERD-12V J			
R639	OB01682A	Carbon Resistor 6.8K ERD-25T J			
R640, 661 671	OB05608A	Carbon Resistor 220 ERD-25V J			

9.15. Logic Control P.C.B. Ass'y

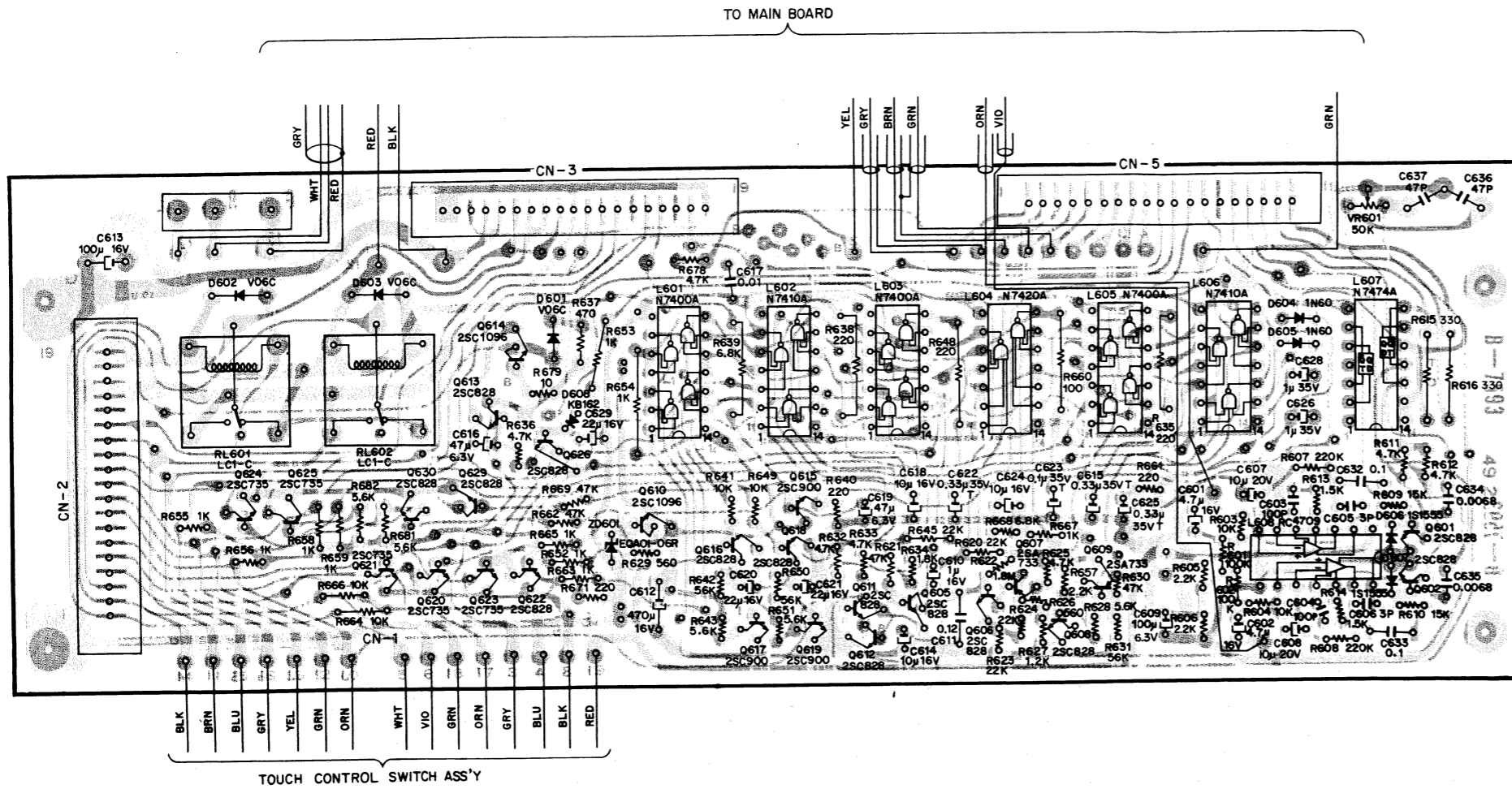

Fig. 9.15

9.16. Touch Switch P.C.B. Ass'y

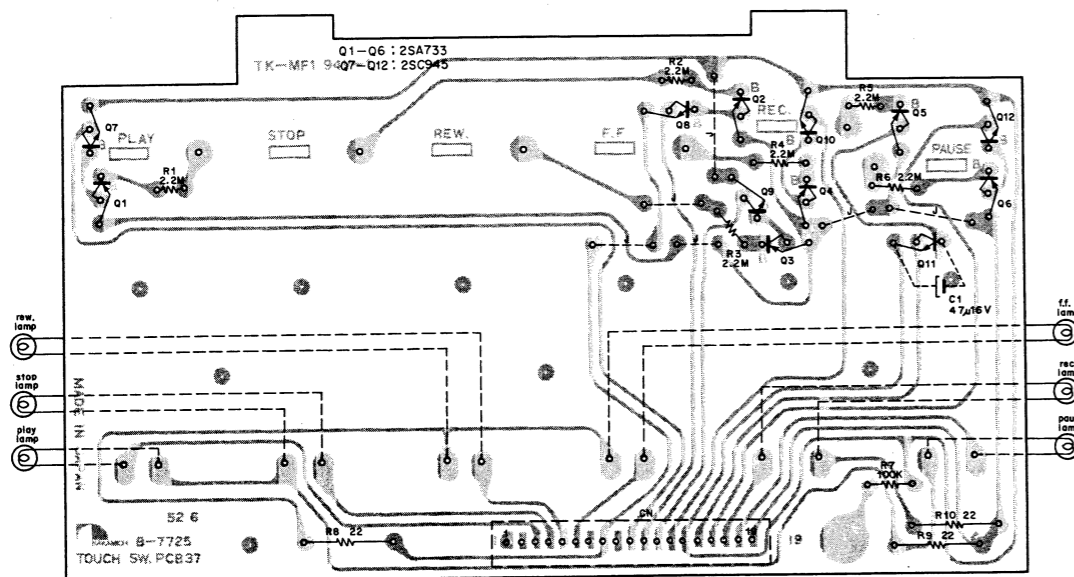

Fig. 9.16

Schematic Ref. No.	Part No.	Description
	BA03857A	Touch Switch P.C.B. Ass'y
Q1, 2, 3	OB07725B	Touch Switch P.C.B.
4, 5, 6	OB06013A	Transistor 2SA733
Q7, 8, 9	OB01872A	Transistor 2SC945
10, 11, 12		
R1, 2, 3	OB05672A	Carbon Resistor 2.2M ERD-25V J
4, 5, 6		
R7	OB01920A	Carbon Resistor 100K ERD-25V J
R8, 9, 10	OB05805A	Fail Safe Type Resistor 22 ERD-14F J
C1	OB01403A	Electrolytic Capacitor 47μ 16V
	0J03670A	Contact Spring (6 pcs.)
	0J03671A	Lamp Shade (1 pce.)
	OB03884A	Pilot Lamp (6 pcs.)
	0J03672A	P.C.B. Holder (1 pce.)
	0J03673A	Rubber Sheet (1 pce.)
	BA03808A	19P Connector Ass'y (1 pce.)
	OB05187A	Insulating Tube 1.2mm (6 pcs.)
	0E00606A	Screw M3x6 Philips Pan Head (3A) (2 pcs.)

9.17. Power Supply P.C.B. Ass'y

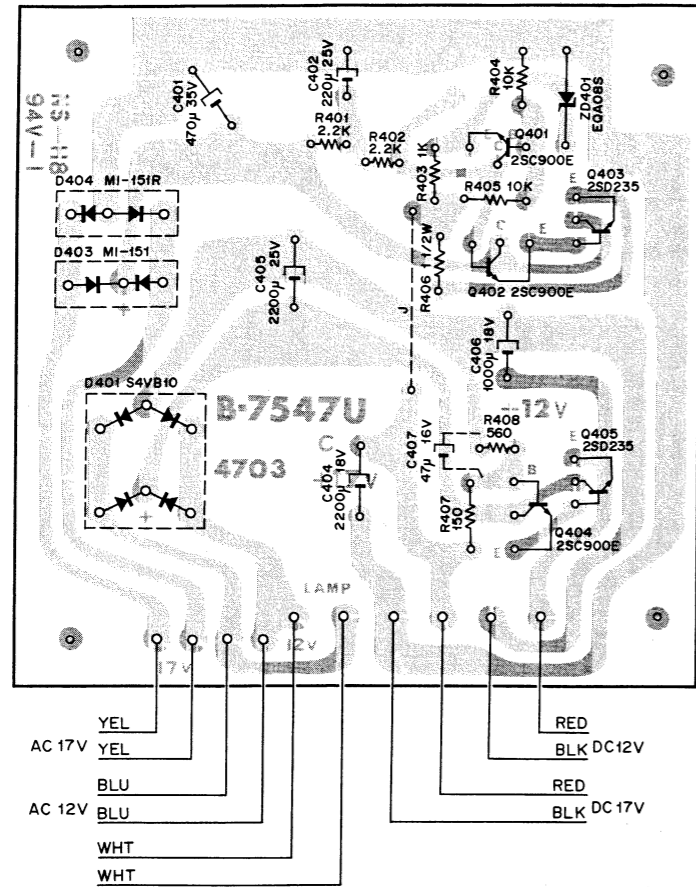

Fig. 9.17

Schematic Ref. No.	Part No.	Description	Schematic Ref. No.	Part No.	Description
	BA03608A	Power Supply P.C.B. Ass'y		0E00597A	Washer 3mm 3x8x0.5 (2 pcs.)
	0B07547U	Power Supply P.C.B.		0E00606A	Screw M3x6 Philips Pan Head (3A) (2 pcs.)
Q401, 402	0B01910A	Transistor 2SC900 (E)		0E00607A	Screw M3x8 Philips Pan Head (3A) (2 pcs.)
Q403, 405	0B01823A	Transistor 2SD235		0E00608A	Screw M3x10 Philips Pan Head (3A) (2 pcs.)
ZD401	0B06004A	Zener Diode EQA08S		0E00507A	Nut Hex. M3 (4 pcs.)
D401	0B06110U	Diode Bridge S4VB10			
D403	0B06092U	Silicon Diode MI-151			
D404	0B06093U	Silicon Diode MI-151R			
R401, 402	0B05566A	Carbon Resistor 2.2K ERD-25V J			
R403	0B01781A	Carbon Resistor 1K ERD-25V J			
R404, 405	0B01833A	Carbon Resistor 10K ERD-25V J			
R406	0B00066A	Carbon Resistor 1 ERD-12T J			
R407	0B05649A	Carbon Resistor 150 ERD-25V J			
R408	0B05678A	Carbon Resistor 560 ERD-25V J			
C401	0B05677A	Electrolytic Capacitor 470μ 35V			
C402	0B01391A	Electrolytic Capacitor 220μ 25V			
C404	0B01835A	Electrolytic Capacitor 2200μ 18V			
C405	0B05654A	Electrolytic Capacitor 2200μ 25V			
C406	0B01673A	Electrolytic Capacitor 1000μ 18V			
C407	0B01403A	Electrolytic Capacitor 47μ 16V			
	0B08001A	Tab (4 pcs.)			
	0J03182B	Power Supply P.C.B. Holder (1 pce.)			
	0J03185C	Heat Sink (1 pce.)			

Schematic Ref. No.	Part No.	Description	Q'ty
A01		Synthesis	1
01	JA03016B	Chassis Ass'y	1
02	HA03599B	Cabinet Ass'y	1
03	0H03366A	Voltage Selector Cover Washer	2
04	0H03334B	Voltage Selector Acrylic Cover	1
05	0H03335A	Voltage Selector Cover	1
06	0H03188A	Button Sheet BC	5
07	0H03248C	Switch Button	5
08	0J03282A	Panel Stopper	1
09	HA03702A	Front Panel Ass'y	1
10	HA03600B	Cassette Lid Ass'y	1
11	HA03608B	Adjustment Lid Ass'y	1
12	HA03694A	Control Panel Ass'y	1
13	HA03609A	Volume Knob Ass'y	1
14	0H03250C	Volume Knob (T)	3
15	0H03251B	Volume Knob (B)	3
16	0A03157B	Front Sash	1
17	0H03273A	Lid Spring Rubber	3
18	CA05238A	Mechanism Ass'y 700II	1
L01	0E00622A	Screw M3x5 Philips Pan Head (2A)	4
L02	0E00633A	Screw M4x6 Philips Pan Head (3A)	8
L03	0E00606A	Screw M3x6 Philips Pan Head (3A)	8
L04	0E00591A	Screw M3x20 Philips Pan Head	2
L05	0E00141A	Washer 4 mm	4
L06	0E00568A	Screw M4x15 Philips Pan Head	4

10. MECHANISM ASS'Y AND PARTS LIST

10.1. Synthesis (A01)

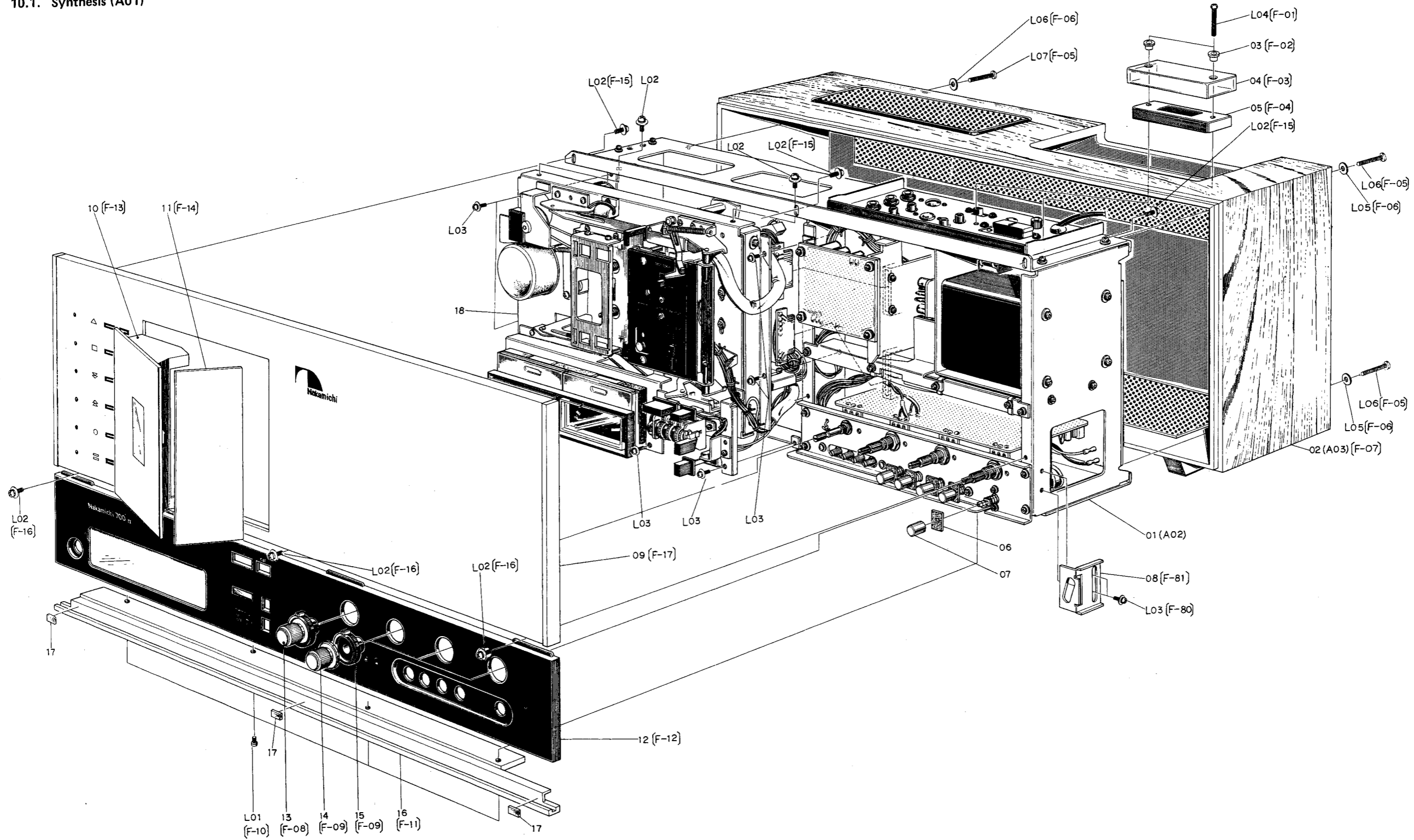

Fig. 10.1

10.2. Chassis Ass'y (A02)

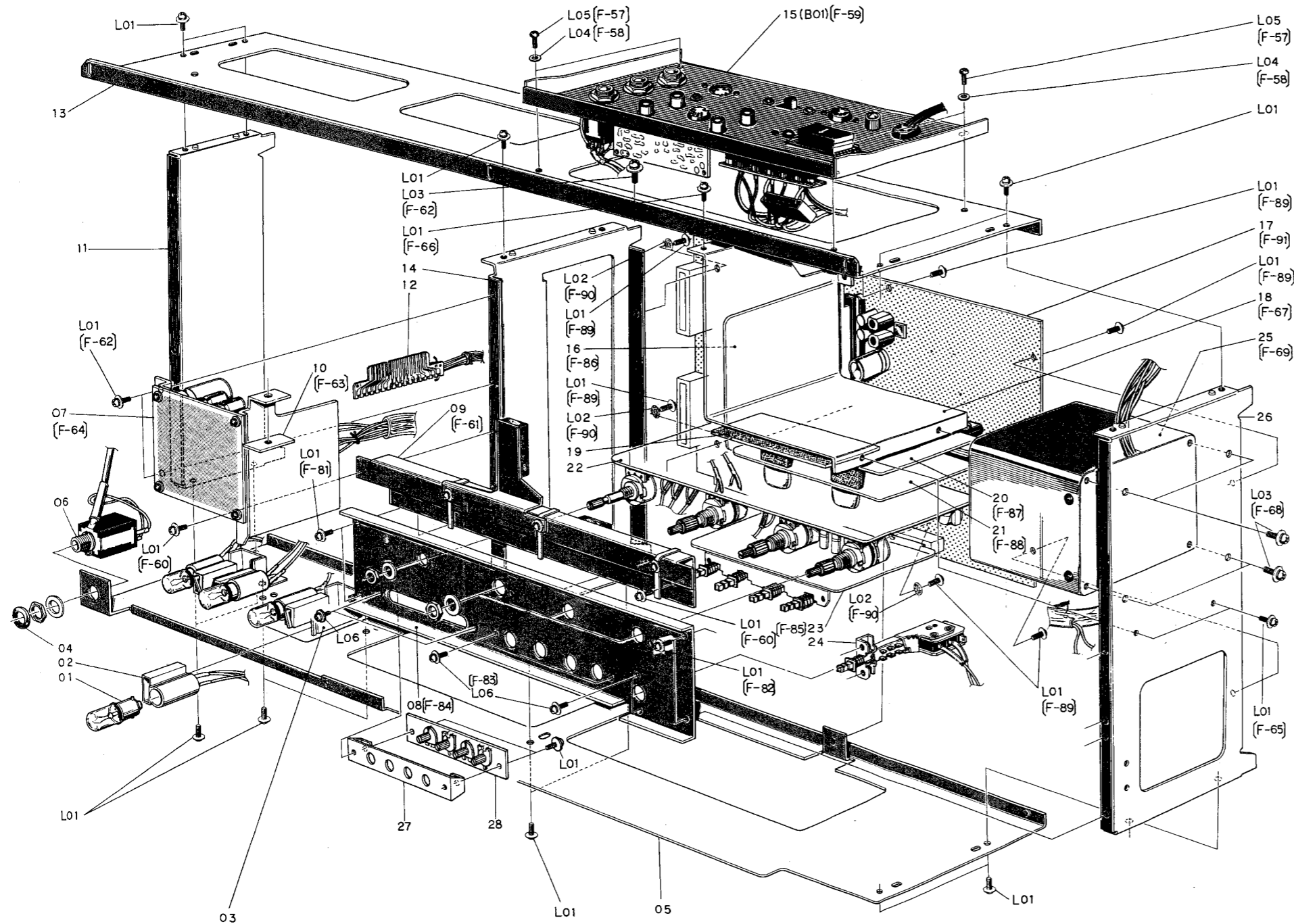

Fig. 10.2

Schematic Ref. No.	Part No.	Description	Q'ty
A02	JA03016B	Chassis Ass'y	1
01	0B08071U	Meter Lamp	4
02	0B03565A	Lamp Socket	4
03	0J03205A	Lamp Bracket	2
04	0J03247A	Headphone Black Washer	1
05	0J03178F	Front Chassis	1
06	0B08078A	Headphone Jack	1
07	BA03608A	Power Supply P.C.B. Ass'y	1
08	0J03172F	Control Chassis	1
09	JA03019A	P.C.B. Holder Ass'y	1
10	0C01162B	Bolt Receptacle Plate	1
11	0J03174D	Side Chassis L	1
12	0B07535D	19P Plug P.C.B. (D)	1
13	0J03179F	Rear Chassis	1
14	0J03175F	Center Chassis	1
15	BA03610B	Rear Panel Ass'y	1
16	BA03796A	Playback Head Amp. P.C.B. Ass'y	1
17	BA03799A	Main P.C.B. Ass'y	1
18	0J03176E	Transformer Shield Plate	1
19	0B08082A	Transformer Shield Plate Insulator	1
20	BA03588A	Playback Dolby NR P.C.B. Ass'y	1
21	BA03589A	Record Dolby NR P.C.B. Ass'y	1
22	BA03797A	Front Control P.C.B. Ass'y	1
23	BA03798A	Switch P.C.B. Ass'y	1
24	0B07185U	Power Switch	1
25	0B06518U	Power Transformer	1
26	0J03173F	Side Chassis R	1
27	0J03582A	Cal. P.C.B. Holder	1
28	BA03815A	Record Cal. P.C.B. Ass'y	1
L01	0E00606A	Screw M3x6 Philips Pan Head (3A)	33
L02	0E00071A	Washer 3 mm Fiber	3
L03	0E00634A	Screw M4x10 Philips Pan Head (3A)	5
L04	0E00157A	Washer 3 mm Plastics	4
L05	0E00593A	Screw M3x6 Philips Binding Head	4
L06	0E00607A	Screw M3x8 Philips Pan Head	6

10.3. Cabinet Ass'y (A03)

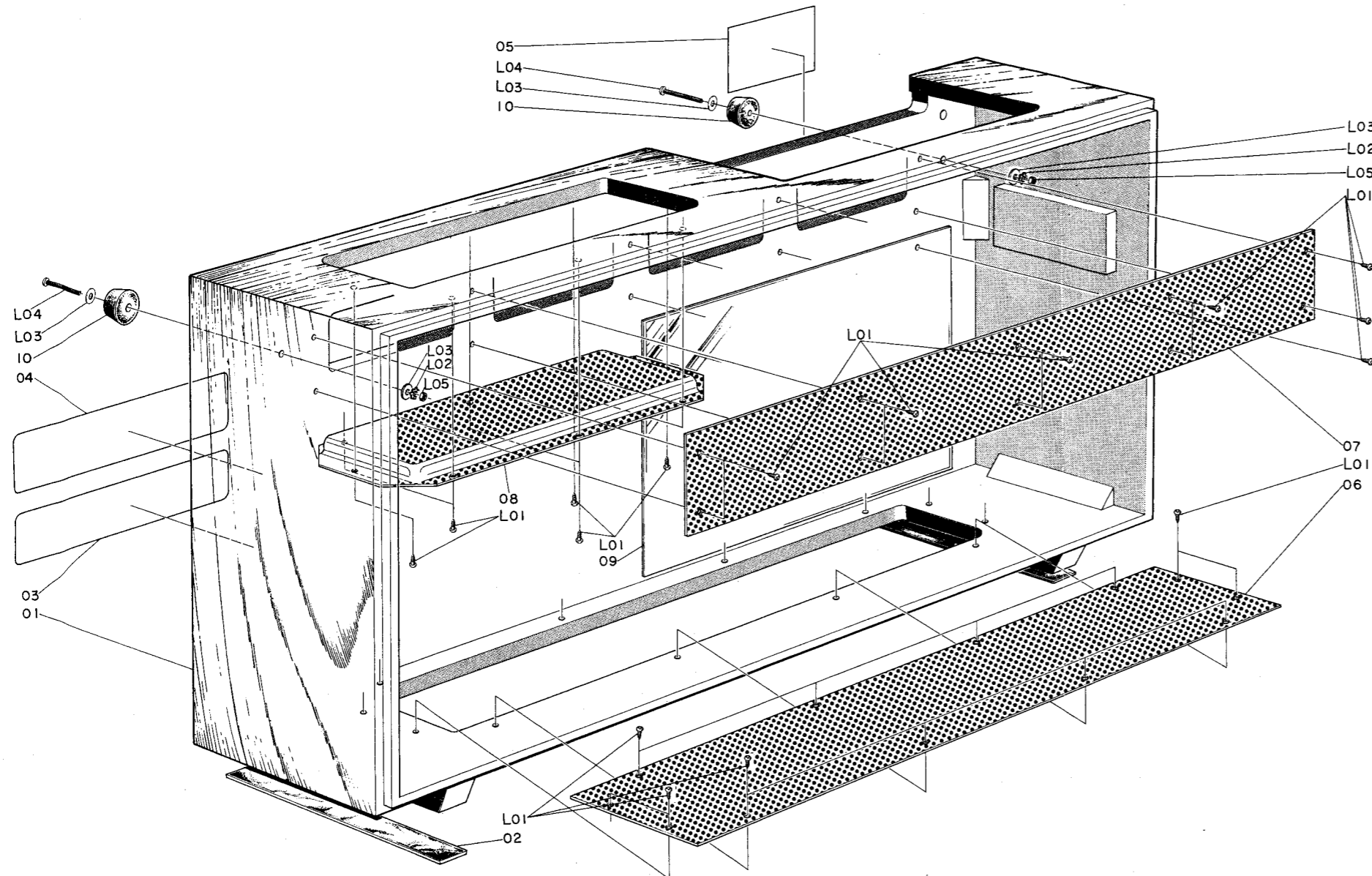

Fig. 10.3

Schematic Ref. No.	Part No.	Description	Q'ty
A03	HA03599B	Cabinet Ass'y	1
01	0A03173C	Cabinet	1
02	0H03286A	Cabinet Foot Stopper	2
03	0M03330A	Dolby NR Label ZT	1
04	0M03339A	Caution Label	1
05	0M03748A	Model Name Label	1
06	0A03171A	Punching Plate F	1
07	0A03172C	Punching Plate G	1
08	0A03170B	Punching Plate E	1
09	0A03169C	Aluminum Shield Plate B	1
10	0J03564A	Foot	2
L01	0E01005A	WS 2.7x8 Philips Round Head	30
L02	0E00172A	Washer 3 mm Toothed Lock	2
L03	0E00178A	Washer 3 mm	4
L04	0E00577A	Screw M3x20 Philips Pan Head	2
L05	0E00507A	Nut Hex. M3	2

10.4. Front Panel Ass'y (A04)

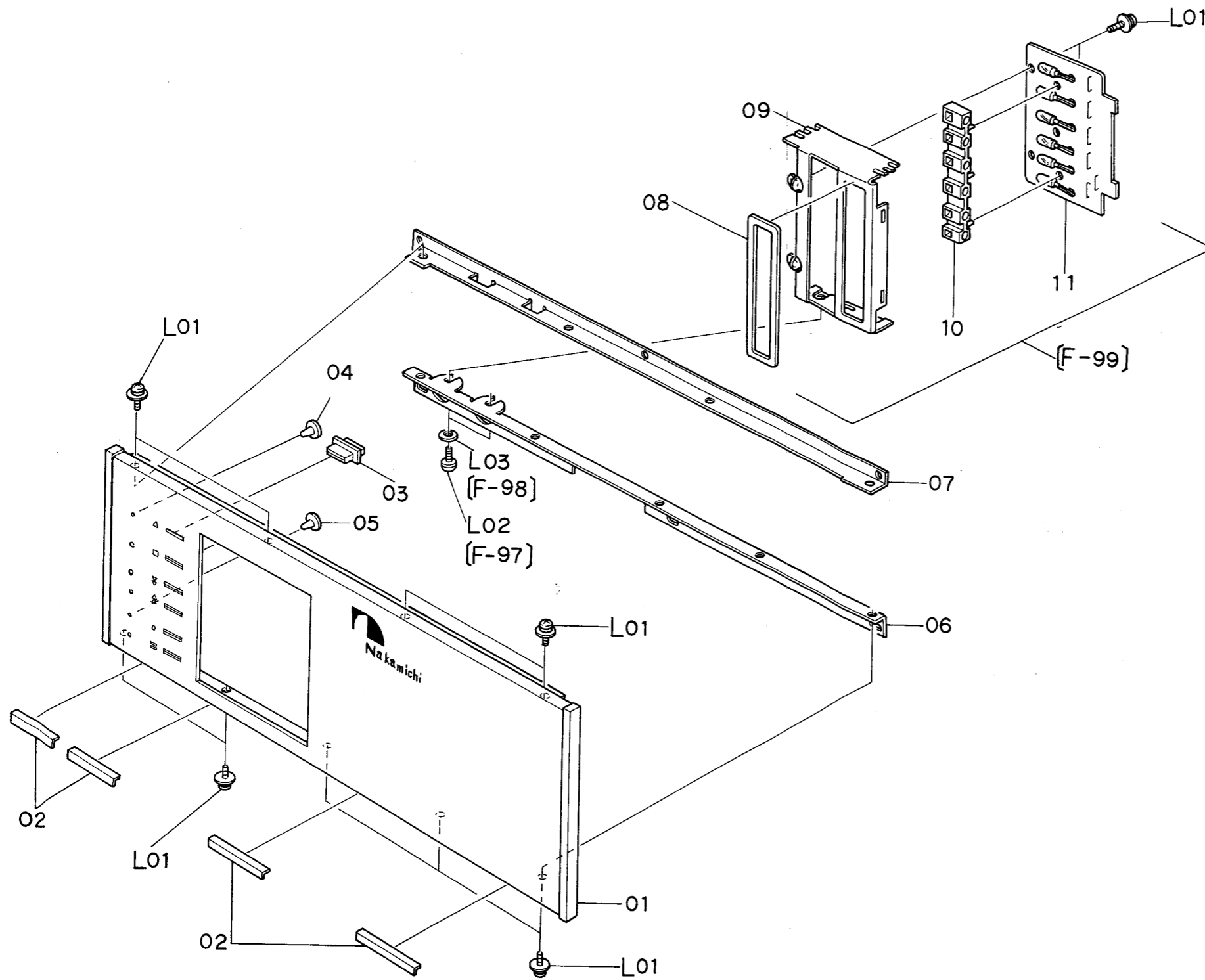

Fig. 10.4

Schematic Ref. No.	Part No.	Description	Q'ty
A04	HA03702A	Front Panel Ass'y	1
01	0H03513A	Front Panel	1
02	0A03153C	Control Panel Rubber	4
03	JA03176E	Touch Plate Ass'y	6
04	0H03511A	Lamp Cover Green	5
05	0H03512A	Lamp Cover Red	1
06	0J03674A	Front Panel Angle F	1
07	0J03187D	Front Panel Angle	1
08	0J03673A	Rubber Sheet	1
09	0J03672A	P.C.B. Holder	1
10	0J03671A	Lamp Shade	1
11	BA03857A	Touch Switch P.C.B. Ass'y 37	1
L01	0E00606A	Screw M3x6 Philips Pan Head (3A)	11
L02	0E00764A	Screw M2.6x6 Philips Pan Head (2A)	2
L03	0E00070A	Washer 2.6 mm	2

10.5. Mechanism Ass'y 700II

10.5.1. Mechanism Ass'y 700II (1/4) (A05-1)

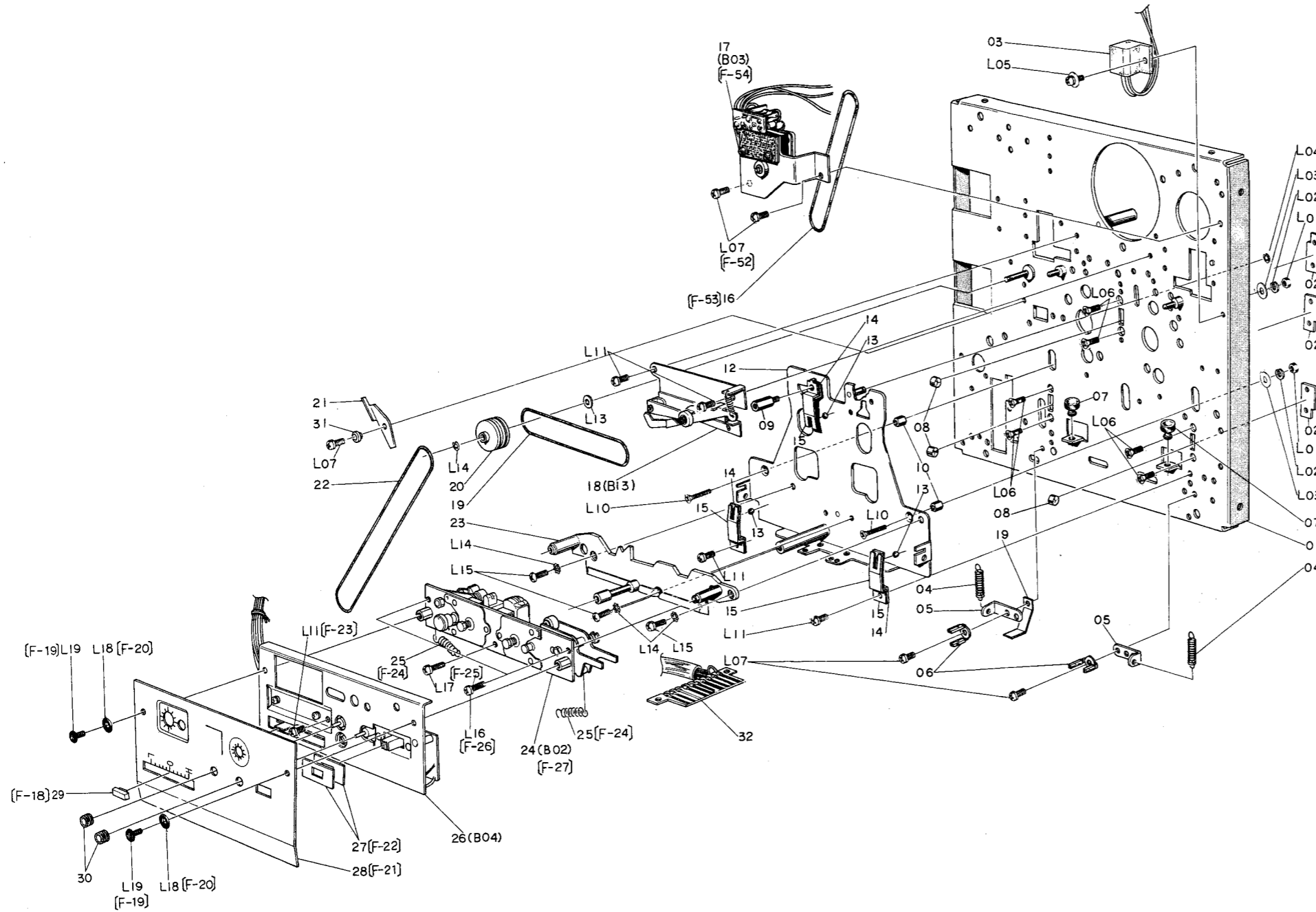

Fig. 10.5.1

Schematic Ref. No.	Part No.	Description	Q'ty
A05-1	CA05238A	Mechanism Ass'y 700II (1/4)	1
01	CA05215A	Mechanism Chassis Ass'y	1
02	0C05457A	Base Roller Holder (A)	3
03	CA05150A	Tape Illumination Lamp Ass'y	1
04	0C05382B	Base Return Spring	2
05	0C05032A	Spring Hook	2
06	0B03067A	Wire Holder	3
07	0C05101C	Base Stopper Rubber	2
08	0C05456B	Base Roller B	3
09	0C05570A	Rear Reference Shaft	1
10	0C05435B	Head Base Holder Nut B	2
12	CA05072A	Head Base Ass'y	1
13	0C02024A	Steel Ball 2 mm	3
14	0C05030A	Ball Retainer Spring	3
15	0C05459A	Ball Retainer Spring B	3
16	0C05465B	Shut-off Belt	1
17	CA05137A	Auto Shut-off Ass'y	1
18	CA05044A	Cassette Holder Ass'y	1
19	0C05334A	Counter Belt B	1
20	0C05335B	Guide Pulley	1
21	0C05358B	Cassette Eject Linkage A	1
22	0C05333A	Counter Belt A	1
23	CA05073A	Head Adjust Plate Ass'y	1
24	CA05168B	Head Mount Base (E) Ass'y	1
25	0C05178F	Pressure Roller Arm Spring	2
26	CA05115A	Mount Base Cover Ass'y	1
27	0J03213C	Test Tone Himelon	2
28	0M03562A	Mount Base Name Plate	1
29	0H03254B	Pitch Control Knob	1
30	0C05376A	LED Escutcheon	2
31	0C05135A	Center Guide	1
32	0B07629B	19P Plug P.C.B.	1
L01	0E00021A	Nut Hex. M2.6	2
L02	0E00026A	Washer 2.6mm Spring	2
L03	0C06295A	Washer 3-9-0.5F	2
L04	0E00222A	E-Ring 2mm	1
L05	0E00606A	Screw M3x6 Philips Pan Head	1
L06	0E00076A	Screw M2.6x4 Philips Countersunk	4
L07	0E00612A	Screw M3x6 Philips Pan Head (2A)	5
L10	0E00056A	Screw M2.6x10 Philips Countersunk	2
L11	0E00622A	Screw M3x5 Philips Pan Head (2A)	5
L13	0C03613A	Washer 1.6mm Mylar	1
L14	0E00172A	Washer 3mm Toothed Lock	3
L15	0E00502A	Screw M3x5 Philips Pan Head	3
L16	0E00624A	Screw M3x10 Philips Pan Head (2A)	2
L17	0E00510A	Screw M3x8 Philips Pan Head (2A)	1
L18	0E00157A	Washer 3mm Plastics	2
L19	0E00656A	Screw M3x4 Philips Truss Head (Bronze)	2

10.5.2. Mechanism Ass'y 700II (2/4) (A05-2)

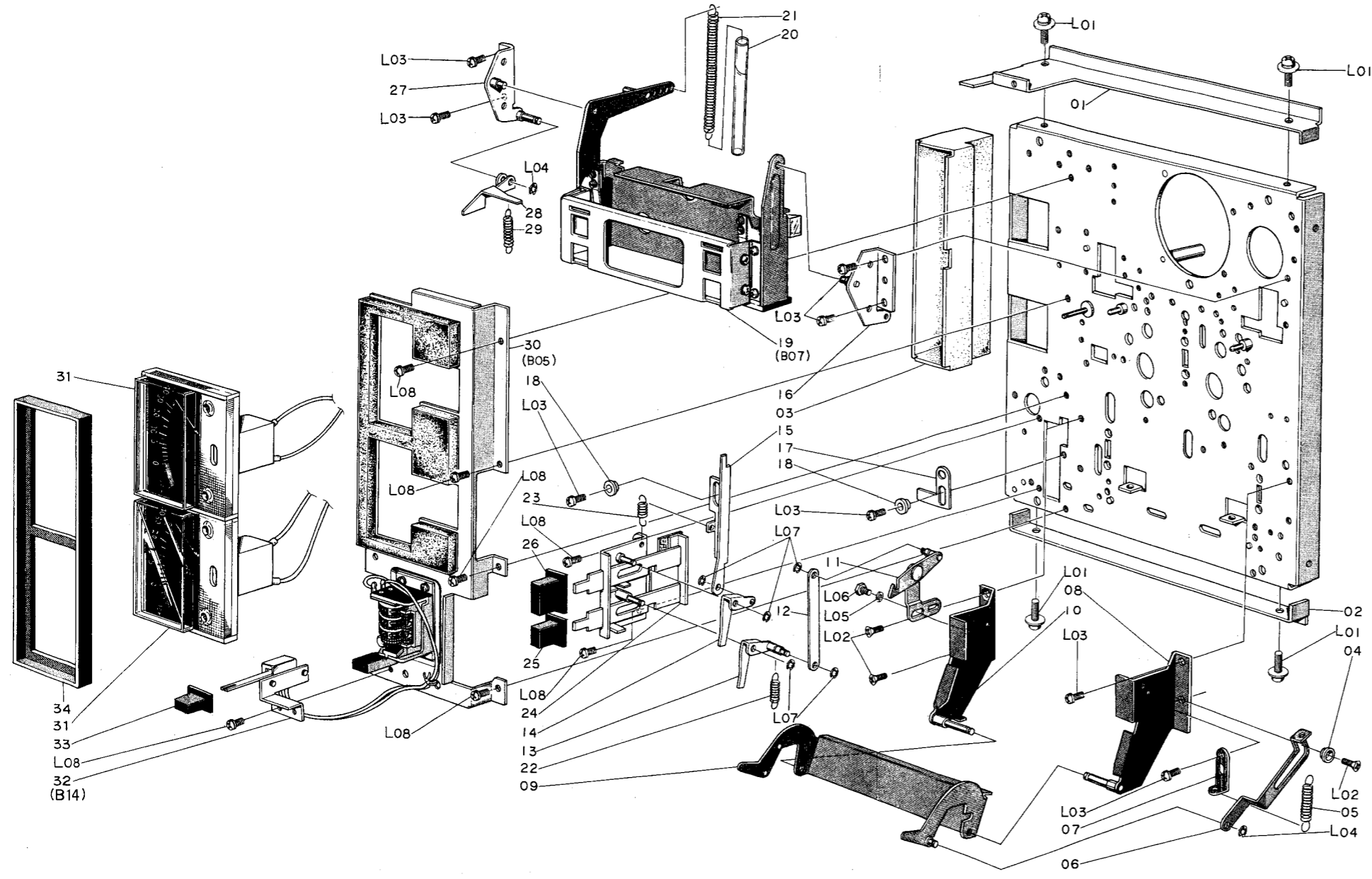

Fig. 10.5.2

Schematic Ref. No.	Part No.	Description	Q'ty
A05-2	CA05238A	Mechanism Ass'y 700II (2/4)	1
01	0J03177B	Mechanism Bracket L	1
02	0J03183B	Mechanism Bracket R	1
03	0J03206A	Meter Lamp Cover	1
04	0C05473A	Center Guide B	1
05	0C05425A	Lid Arm Spring R	1
06	0C05427B	Lid Arm Stopper Plate	1
07	0C05032A	Spring Hook	1
08	CA05109A	AJ Plate Holder L Ass'y	1
09	CA05118A	Lid Arm Ass'y	1
10	CA05112A	AJ Plate Holder R Ass'y	1
11	CA05111A	AJ Lock Plate Ass'y	1
12	0C05360B	AJ Eject Linkage	1
13	CA05108A	AJ Eject Arm Ass'y	1
14	CA05107A	Cassette Eject Arm Ass'y	1
15	0C05359F	Cassette Eject Linkage	1
16	CA05092A	Cassette Holder Ass'y R	1
17	0C05367C	Eject Stopper	1
18	0C05135A	Center Guide	2
19	CA05148A	Cassette Well Ass'y 37	1
20	0C05536A	Well Spring Tube	1
21	0C05123B	Well Spring	1
22	0C05366A	AJ Eject Spring	1
23	0C05365A	Cassette Eject Spring	1
24	CA05106A	Eject Bar Bracket Ass'y	1
25	0H03247B	AJ Button 37	1
26	0H03246B	Eject Button 37	1
27	CA05091A	Cassette Holder Ass'y L	1
28	0C05116B	Sensor Guide B	1
29	0C05127A	Well Stopper Spring	1
30	CA05149A	Meter Chassis Ass'y	1
31	0B08285A	Level Meter	2
32	BA03680A	Memory Switch Ass'y	1
33	0H03245D	Memory Switch Button	1
34	0A03152C	Meter Escutcheon	1
L01	0E00643A	Screw M4x8 Philips Pan Head (3A)	4
L02	0E00533A	Screw M3x5 Philips Countersunk	3
L03	0E00612A	Screw M3x6 Philips Pan Head (2A)	7
L04	0E00222A	E-Ring 2mm	2
L05	0E00037A	Washer 3mm Spring	1
L06	0E00643A	Bolt M3x5 Hex. Socket Head	1
L07	0E00042A	E-Ring 1.5mm	5
L08	0E00510A	Screw M3x5 Philips Pan Head (2A)	7

10.5.3. Mechanism Ass'y 700II (3/4) (A05-3)

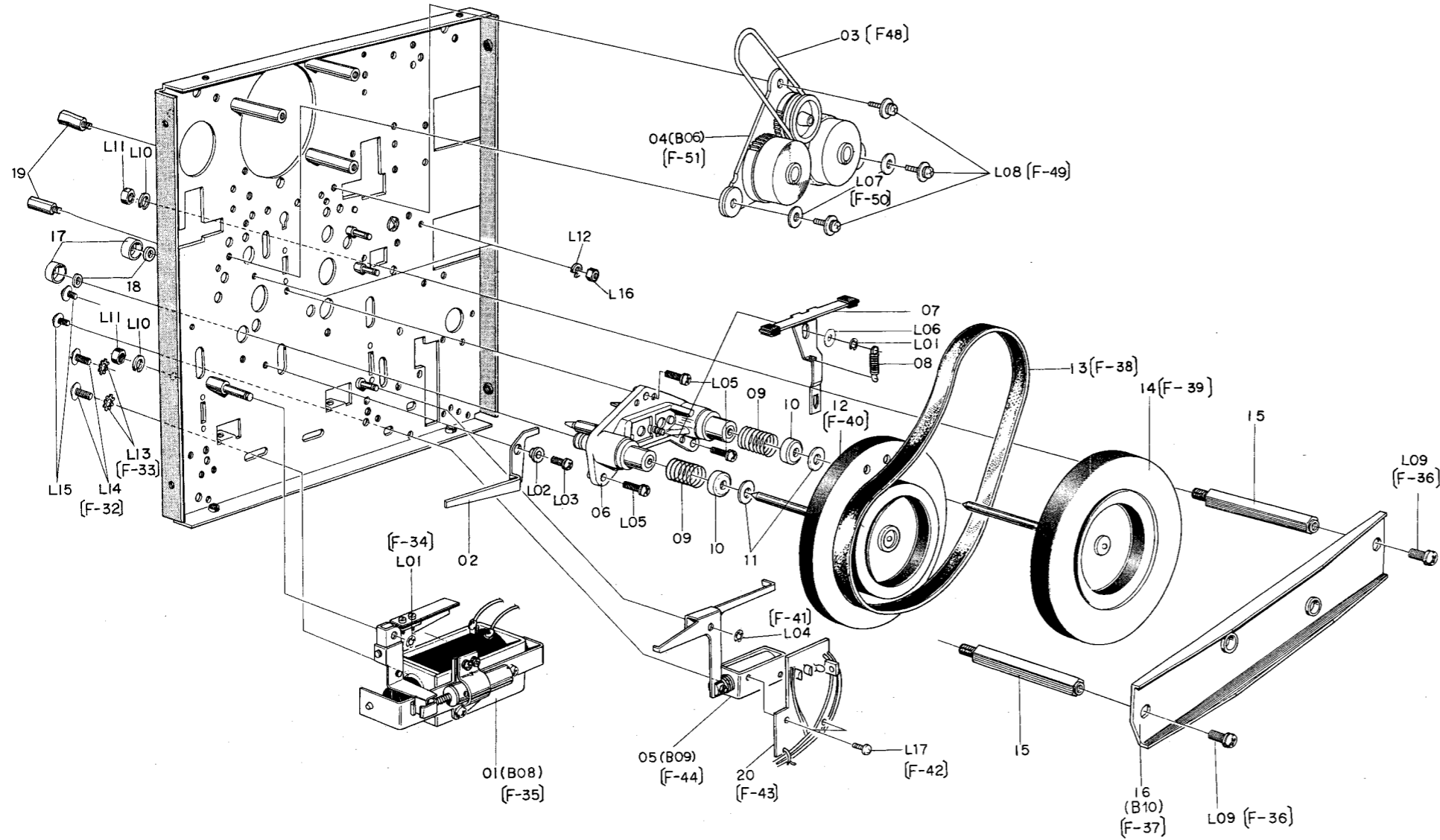

Fig. 10.5.3

Schematic Ref. No.	Part No.	Description	Q'ty
A05-3	CA05238A	Mechanism Ass'y 700II (3/4)	1
01	CA05145A	Head Base Solenoid Ass'y	1
02	0C05100B	Base Switch Arm	1
03	0C05699A	Center Drive Belt	1
04	CA05219C	Ball Drive Mechanism Ass'y	1
05	CA05053A	Brake Solenoid Ass'y	1
06	CA05212A	Capstan Flange Holder Ass'y D	1
07	CA05222A	Brake Arm Ass'y	1
08	0C05084B	Brake Arm Spring	1
09	0C05514B	Thrust Spring	2
10	0C05495B	Flange Thrust Cap	2
11	0C05552A	Flywheel Thrust Washer	2
12	CA05006H	Flywheel Ass'y A	1
13	0C05104A	Capstan Belt	1
14	CA05007G	Flywheel Ass'y B	1
15	0C05496B	Flywheel Holder Stud B	2
16	CA05171A	Flywheel Holder Ass'y	1
17	0C05511B	Flange Cap	2
18	0C05512A	Flange Felt	2
19	0C05568A	Front Reference Shaft	2
20	BA03836A	Brake Solenoid P.C.B. Ass'y	1
L01	0E00181A	E-Ring 3mm	2
L02	0C05135A	Center Guide	1
L03	0E00612A	Screw M3x6 Philips Pan Head (2A)	1
L04	0E00222A	E-Ring 2mm	1
L05	0E00510A	Screw M3x8 Philips Pan Head (2A)	3
L06	0E00031A	Washer 4mm	1
L07	0E00597A	Washer 3-8-0.5	2
L08	0E00607A	Screw M3x8 Philips Pan Head (3A)	3
L09	0E00664A	Screw M4x8 Philips Pan Head (2A)	2
L10	0E00574A	Washer 4mm Spring	2
L11	0E00669A	Nut Hex. M4	2
L12	0E00581A	Washer 3mm Spring	2
L13	0E00172A	Washer 3mm Toothed Lock	2
L14	0E00614A	Screw M3x6 Philips Pan Head Triple	2
L15	0E00259A	Screw M2.6x4 Philips Pan Head Triple	2
L16	0E00507A	Nut Hex. M3	2
L17	0E00226A	Screw M2.6x4 Philips Pan Head	2

10.5.4. Mechanism Ass'y 700II (4/4) (A05-4)

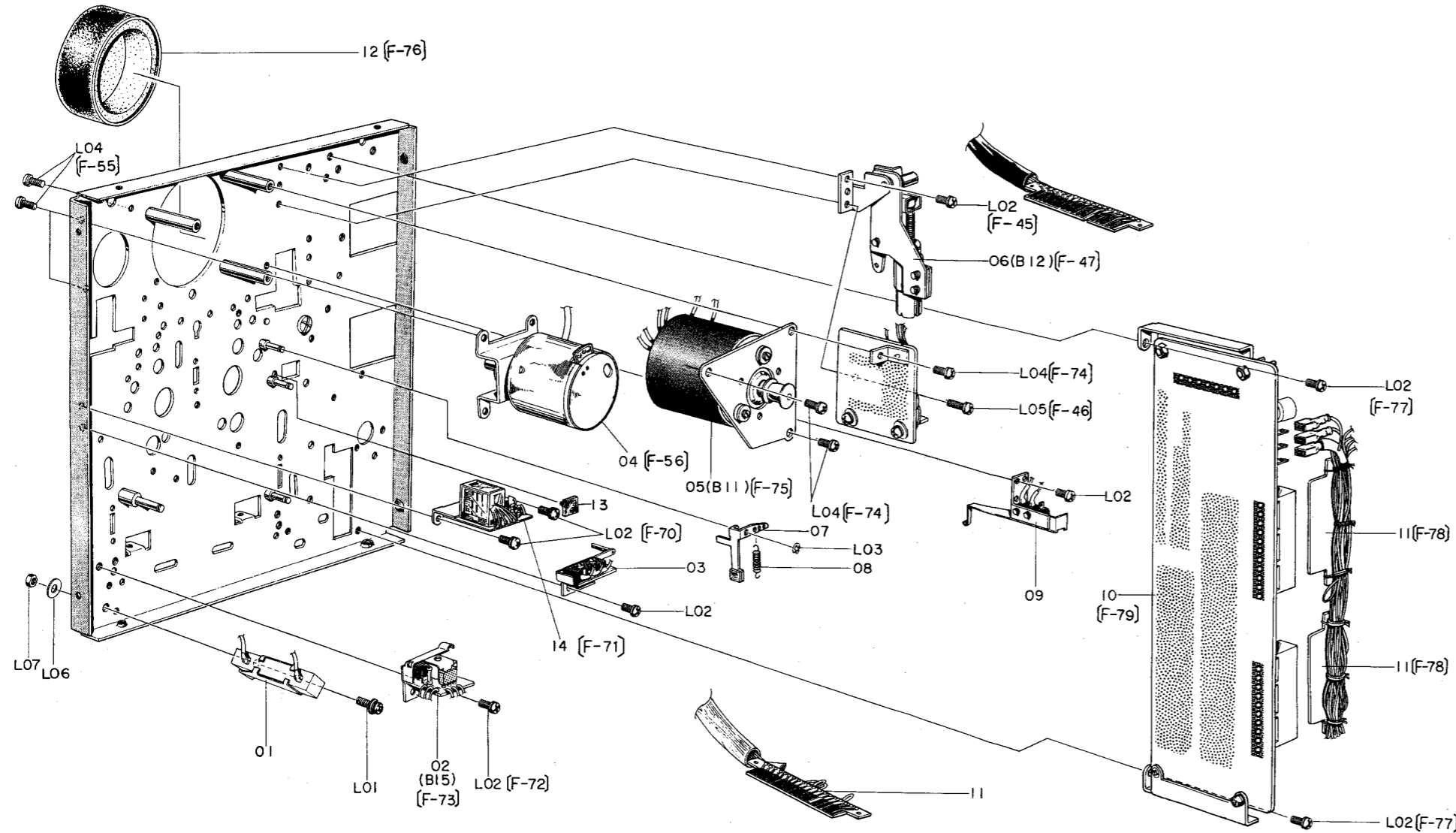

Fig. 10.5.4

Schematic Ref. No.	Part No.	Description	Q'ty
A05-4	CA05238A	Mechanism Ass'y 700II (4/4)	1
01	0B05754A	Cement Resistor 15 10W	1
02	CA05132A	Base Switch Ass'y	1
03	CA05026A	Cassette Sensor Ass'y	1
04	CA05221A	Reel Motor Ass'y	1
05	CA05220A	Capstan Motor Ass'y	1
06	CA05134A	Eject Damper Bracket Ass'y	1
07	CA05223A	Back Tension Arm Ass'y	1
08	0C05673A	Back Tension Spring	1
09	CA05031A	Record Sensor Ass'y	1
10	BA03953A	Logic Control P.C.B. Ass'y	1
11	0B07629B	19P Plug P.C.B.	3
12	CA05158A	Motor Cap Ass'y	1
13	0C05126A	Well Stopper Rubber	1
14	BA03813A	Reel Motor Governor Ass'y	1
L01	0E00607A	Screw M3x8 Philips Pan Head (3A)	1
L02	0E00622A	Screw M3x5 Philips Pan Head (2A)	8
L03	0E00222A	E-Ring 2mm	1
L04	0E00612A	Screw M3x6 Philips Pan Head (2A)	5
L05	0E00510A	Screw M3x8 Philips Pan Head (2A)	1
L06	0E00597A	Washer 3mm	1
L07	0E00507A	Nut Hex. M3	1

10.6. Rear Panel Ass'y (B01)

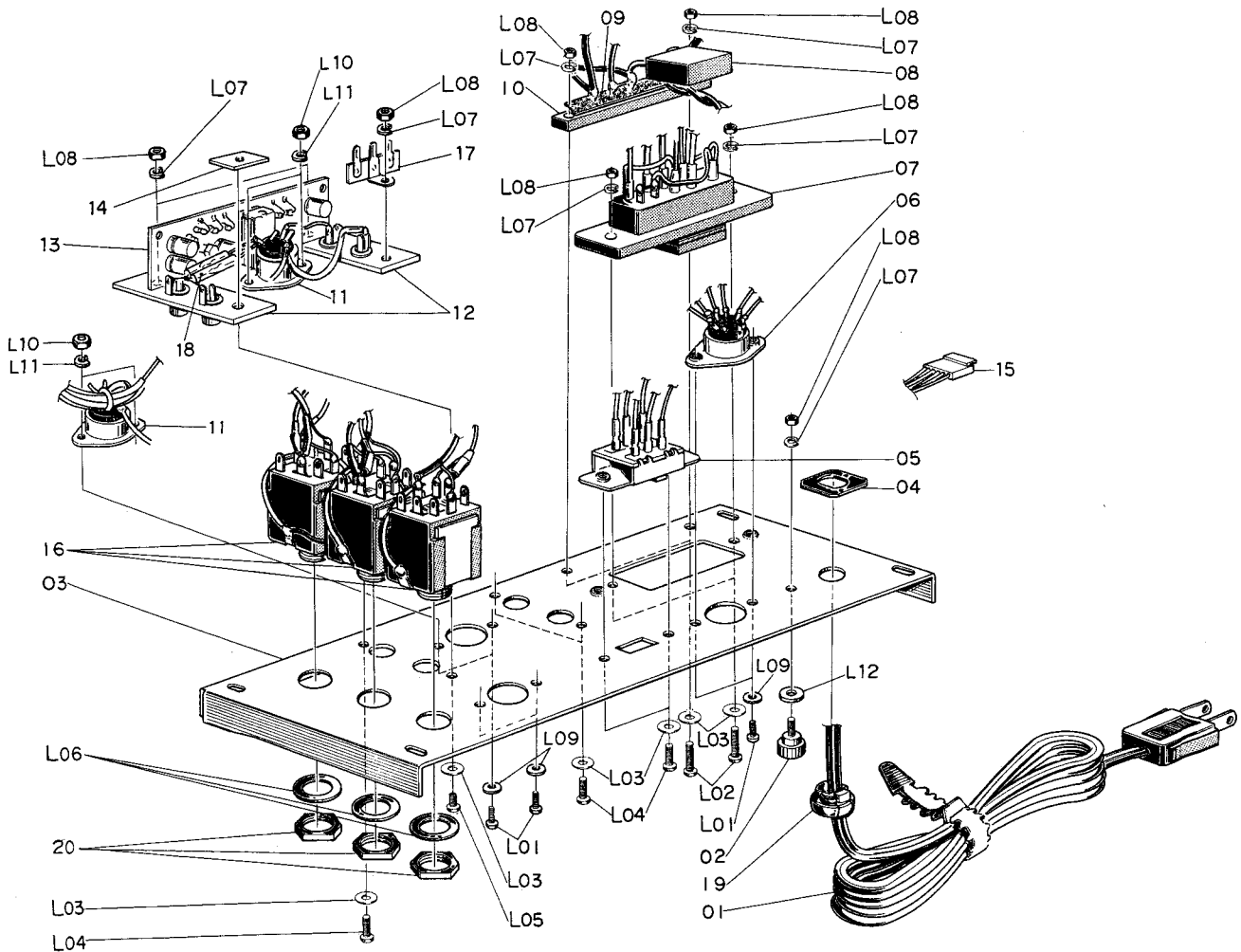

Fig. 10.6

Schematic Ref. No.	Part No.	Description	Q'ty	Schematic Ref. No.	Part No.	Description	Q'ty
B01	BA03610B	Rear Panel Ass'y	1	18	0B01887A	Carbon Resistor 5.6K ERD-25T J	2
				19	0B08037A	Cord Bushing	1
01	0B08350A	Power Cord	1	20	0B08204A	Jack Nut Black	3
02	0B03920B	Ground Terminal	1	L01	0E00654A	Screw M2.6x6 Philips Pan Head (Bronze)	6
03	0A03150G	Rear Panel	1	L02	0E00655A	Screw M3x10 Philips Pan Head (Bronze)	4
04	0A03154B	Cord Spacer	1	L03	0E00157A	Washer 3mm Plastics	8
05	0B07030A	MPX Switch	1	L04	0E00588A	Screw M3x8 Philips Pan Head (Bronze)	5
06	0B08075A	7P DIN Socket	1	L05	0E00657A	Screw M3x5 Philips Pan Head (Bronze)	1
07	0B03877B	Voltage Selector	1	L06	0E00647A	Washer 12mm Plastics	3
08	0B08240U	Spark Killer	1	L07	0E00581A	Washer 3mm Spring	8
09	0B03863A	5P Terminal Insulator A	1	L08	0E00507A	Nut Hex. M3	8
10	0B08025U	5P Terminal Strip	1	L09	0E00651A	Washer 2.6mm Plastics	6
11	0B08044A	DIN Socket	2	L10	0E00021A	Nut Hex. M2.6	4
12	0B03072A	2P Pin Jack	2	L11	0E00026A	Washer 2.6mm Spring	4
13	BA03810A	DIN Amp. P.C.B. Ass'y	1	L12	0E00597A	Washer 3-8-0.5	1
14	0J03248A	Bolt Receptacle Plate	1				
15	0B08192A	6P-H Connector (B)	1				
16	0B03881A	Mic Jack	3				
17	0B04042A	Lug Terminal 1L2P	1				
18	0B05575A	Carbon Resistor 560 ERD-25T J	2				
18	0B01846A	Carbon Resistor 4.7K ERD-25T J	2				

10.7. Head Mount Base E Ass'y (B02)

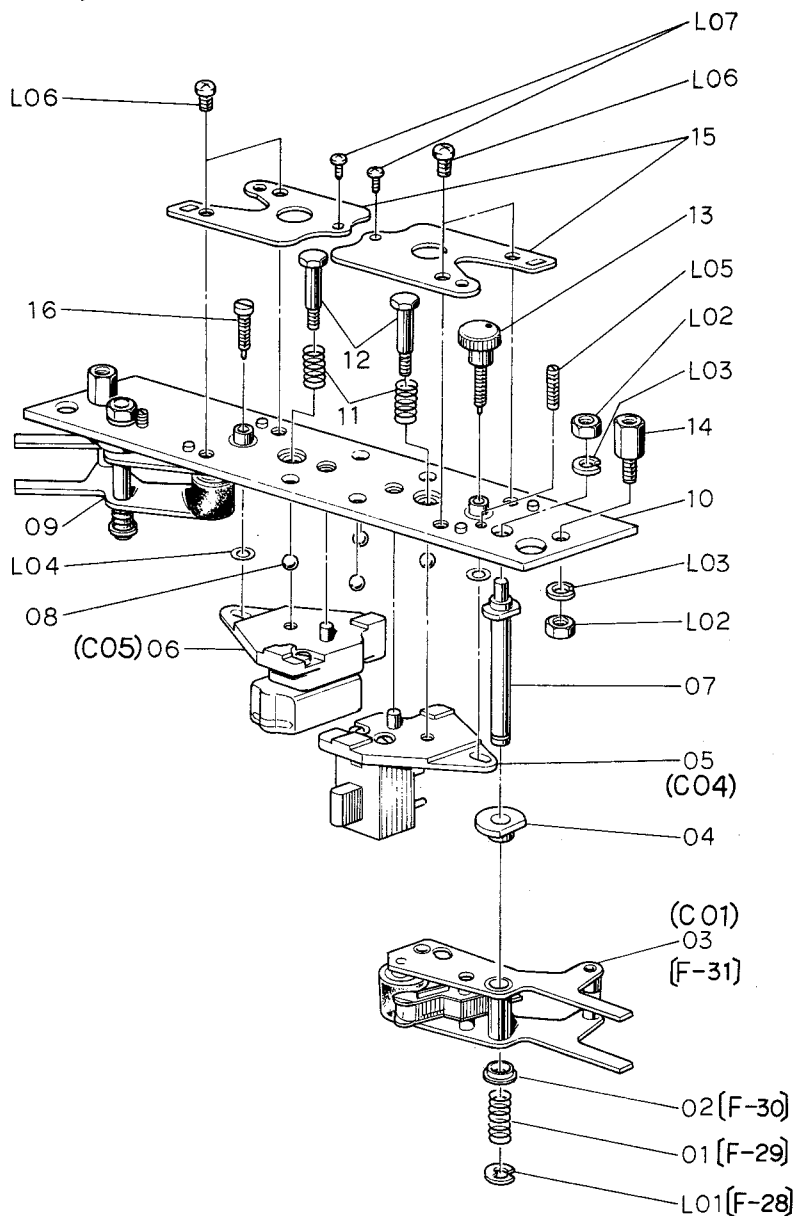

Fig. 10.7

Schematic Ref. No.	Part No.	Description	Q'ty	Schematic Ref. No.	Part No.	Description	Q'ty
B02	CA05168B	Head Mount Base (E) Ass'y	1	13	0C05562B	R.H. Azimuth Screw 37	1
01	0C05179C	Pressure Arm Shaft Spring	2	14	0C05565B	Plate Stud A	2
02	0C05175B	Pressure Arm Collar (B)	2	15	0C05556B	Head Pressure Plate	2
03	CA05208B	Pressure Roller Arm D Ass'y (B)	1	16	0C05558B	P.H. Azimuth Screw	1
04	0C05174C	Pressure Arm Collar (A)	2	L01	0E00222A	E-Ring 2mm	2
05	CA05174A	Record Head Ass'y	1	L02	0E00507A	Nut Hex. M3	4
06	CA05173B	Playback Head Ass'y	1	L03	0E00581A	Washer 3mm Spring	4
07	0C05477B	Pressure Arm Shaft (C)	2	L04	0C05567A	Washer 1mm	2
08	0C03595A	Steel Ball 3mm	4	L05	0E00629A	Screw M2.6x8 Cup Point	2
09	CA05207A	Pressure Roller Arm D Ass'y	1	L06	0E00120A	Screw M2.6x3 Philips Pan Head	4
10	CA05169C	Head Mount Base F Ass'y	1	L07	0E00692A	Screw M2x2.5 Philips Pan Head (JCIS)	2
11	0C05555A	Head Spring (B)	2				
12	0C05559A	Head Spring Shaft (A)	2				

10.8. Auto Shut-off Ass'y (B03)

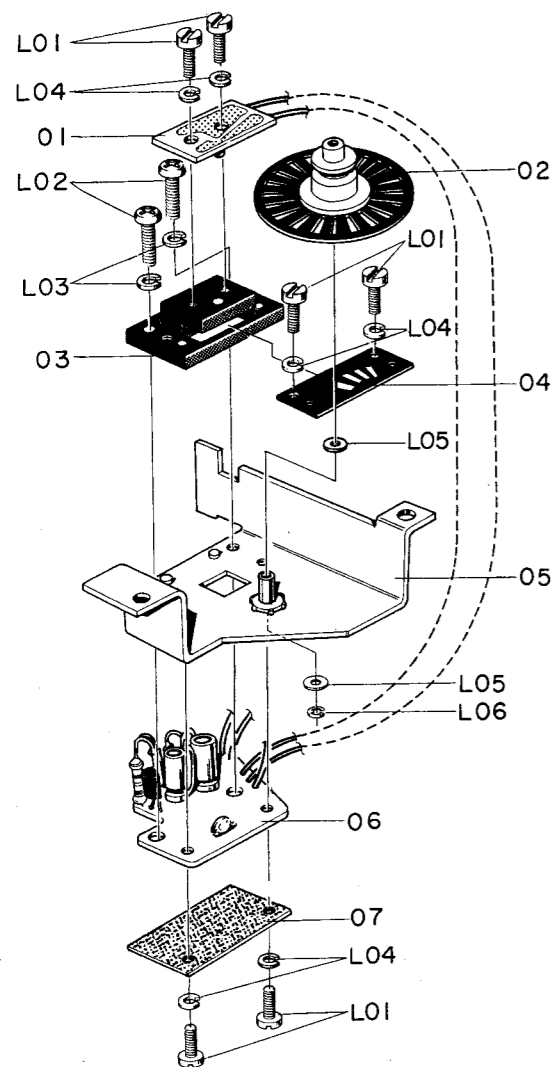

Fig. 10.8

10.9. Mount Base Cover Ass'y (B04)

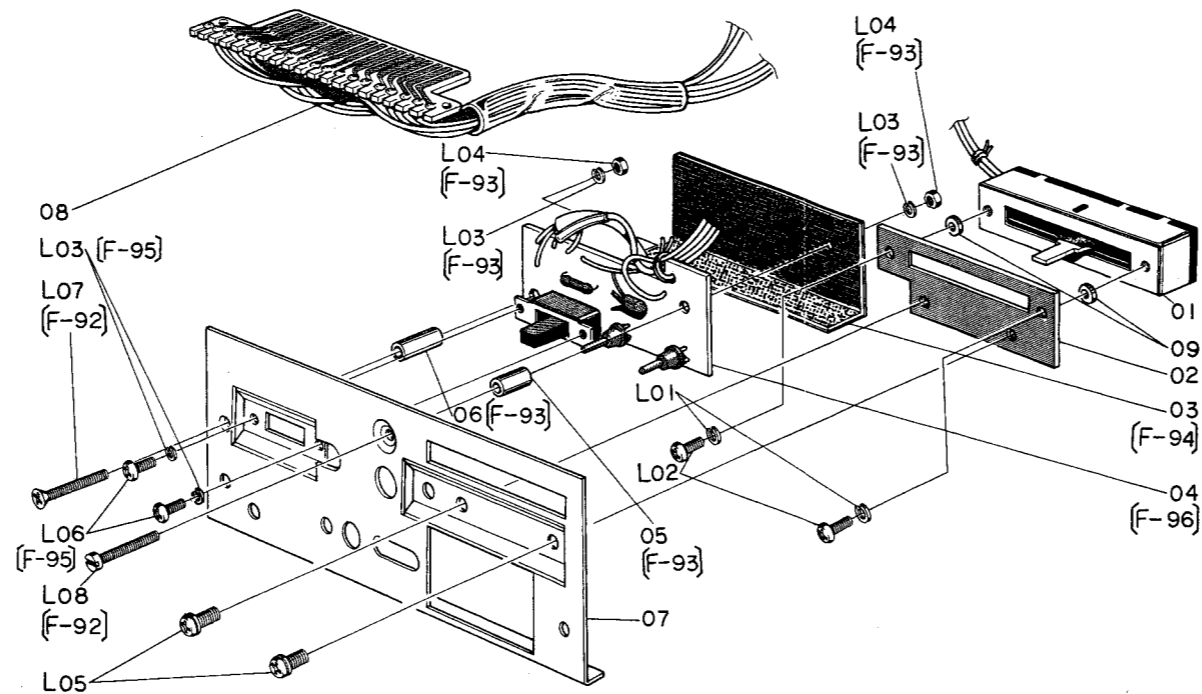

Fig. 10.9

10.10. Meter Chassis Ass'y (B05)

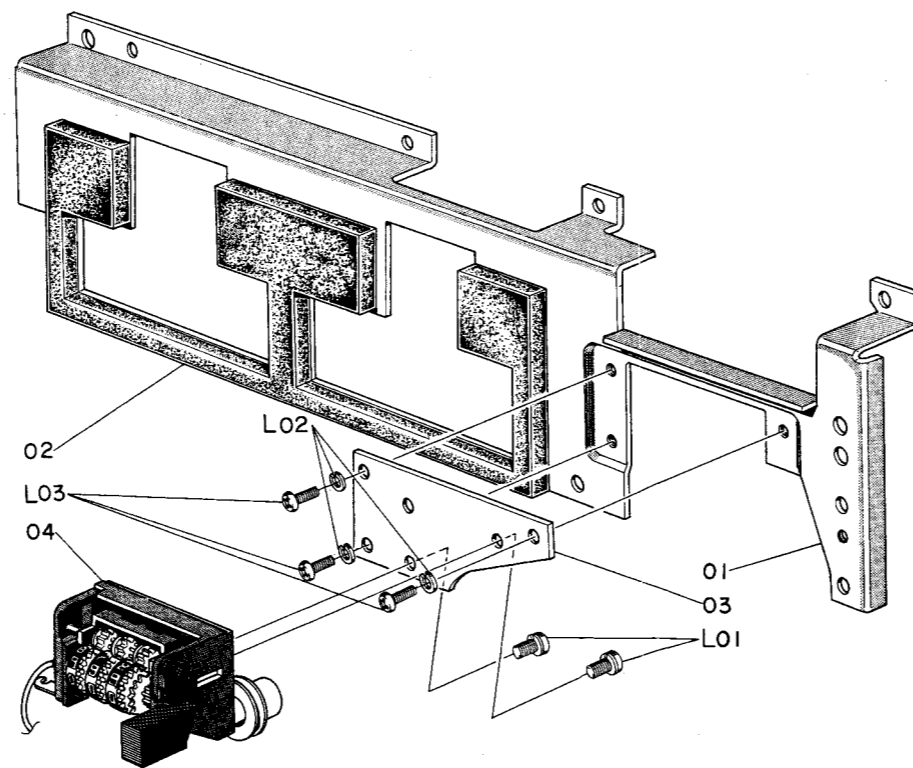

Fig. 10.10

Schematic Ref. No.	Part No.	Description	Q'ty
B03	CA05137A	Auto Shut-off Ass'y	1
01	BA03663A	Shut-off Luminous P.C.B. Ass'y	1
02	CA05156A	Shut-off Blade Ass'y	1
03	0C05461C	Shut-off Holder	1
04	0C05467A	Shut-off Shutter	1
05	CA05138A	Shut-off Base Ass'y	1
06	BA03664A	Shut-off Sensor P.C.B. Ass'y	1
07	0C05476B	Photo Transistor P.C.B. Cover	1
L01	0E00166A	Screw M2x4 Cylinder Head	6
L02	0E00121A	Screw M2.6x6 Philips Pan Head	2
L03	0E00026A	Washer 2.6mm Spring	2
L04	0E00025A	Washer 2mm Spring	6
L05	0C03613A	Washer 1.6mm Mylar	2
L06	0E00165A	E-Ring 1.2mm	1
B04	CA05115A	Mount Base Cover Ass'y	1
01	0B07041A	Pitch Control Volume 500 (B)	1
02	0C05482B	Volume Hold Plate	1
03	0B08105B	Shield Plate	1
04	BA03678B	Osc. Switch P.C.B. Ass'y 37	1
05	0J03204B	Osc. P.C.B. Stud	1
06	0J03251A	Osc. P.C.B. Stud B	1
07	0C05563A	Mount Base Cover C	1
08	0B07629B	19P Plug P.C.B.	1
09	0J03252B	Volume Stud	2
L01	0E00026A	Washer 2.6mm Spring	2
L02	0E00219A	Screw M2.6x5 Philips Pan Head	2
L03	0E00025A	Washer 2mm Spring	4
L04	0E00176A	Nut Hex. M2	2
L05	0E00622A	Screw M3x5 Philips Pan Head (2A)	2
L06	0E00124A	Screw M2x4 Philips Pan Head	2
L07	0E00663A	Screw M2x15 Countersunk	1
L08	0E00642A	Screw M2x15 Cylinder Head	1
B05	CA05149A	Meter Chassis Ass'y	1
01	0J03192B	Meter Chassis	1
02	0J03194B	Meter Cushion	1
03	0J03193A	Counter Holder	1
04	CA05097A	Tape Counter Ass'y	1
L01	0E00612A	Screw M3x6 Philips Pan Head (2A)	2
L02	0E00026A	Washer 2.6mm Spring	3
L03	0E00219A	Screw M2.6x5 Philips Pan Head	3

10.11. Ball Drive Mechanism Ass'y (B06)

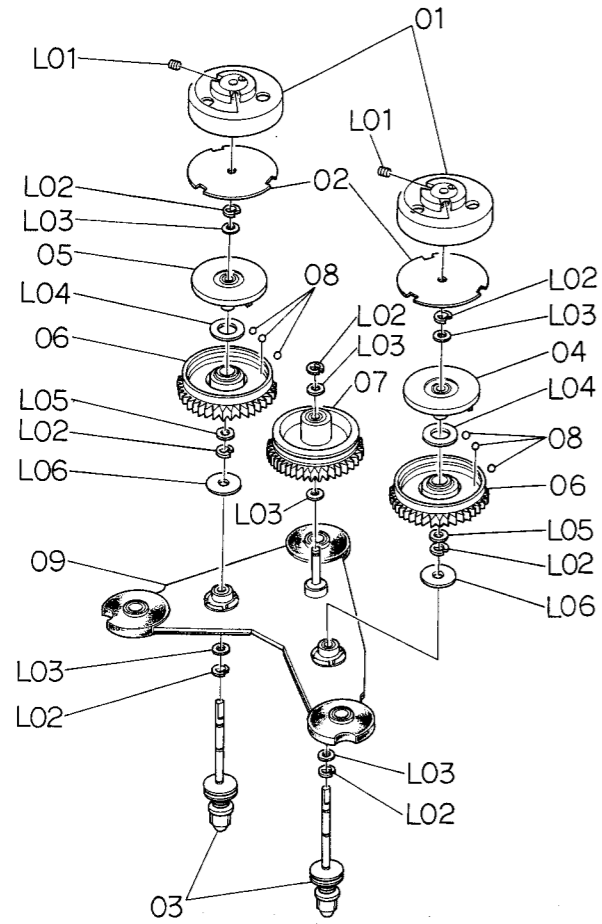

Fig. 10.11

10.13. Head Base Solenoid (B08)

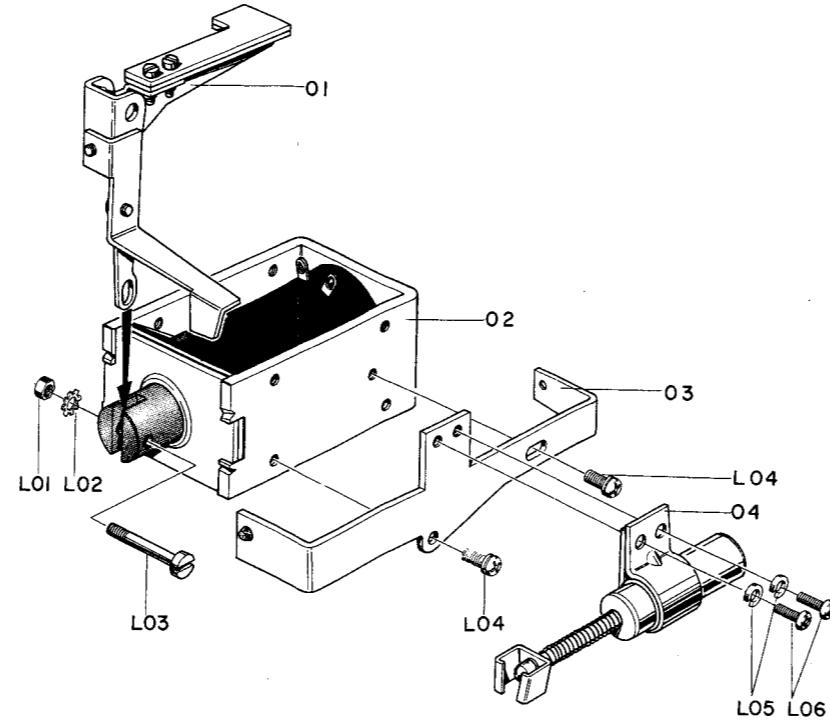

Fig. 10.13

10.12. Cassette Well Ass'y 37 (B07)

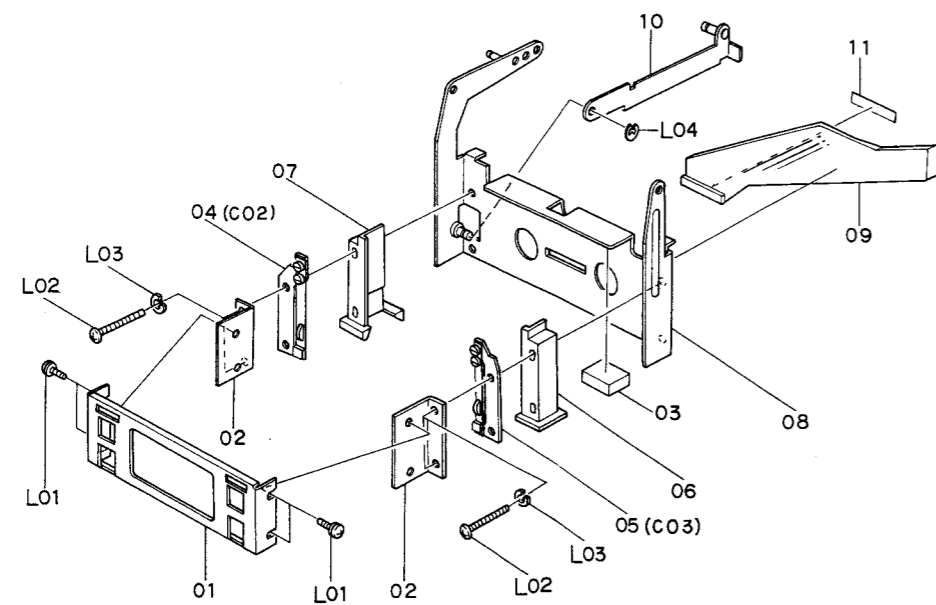

Fig. 10.12

10.14. Brake Solenoid Ass'y (B09)

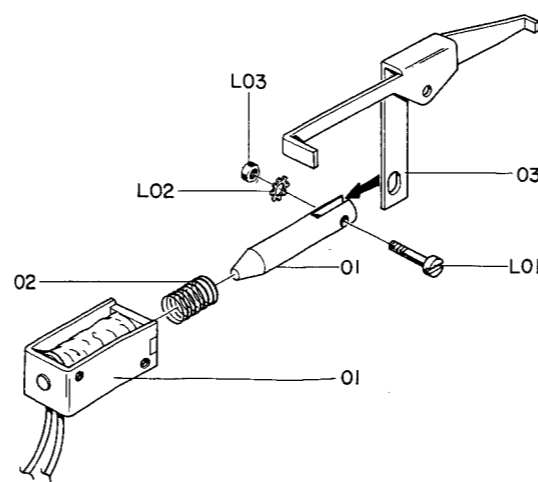

Fig. 10.14

Schematic Ref. No.	Part No.	Description	Q'ty
B06	CA05219C	Ball Drive Mechanism Ass'y	1
01	CA05217A	Brake Drum Ass'y	2
02	0C05666A	Clutch Plate B	2
	0C05667B	Clutch Felt	2
03	CA05235A	Reel Hub C Ass'y	2
04	CA05230C	Clutch Pulley R Ass'y	1
05	CA05231C	Clutch Pulley F Ass'y	1
06	CA05233A	Reel Hub Gear B Ass'y	2
07	CA05232C	Center Gear Ass'y	1
08	0C02024A	Ball 2mm	6
09	CA05214B	Reel Holder Ass'y	1
L01	0E00626A	Screw M2x3 Cup Point	2
L02	0E00042A	E-Ring 1.5mm	7
L03	0C05672B	Washer 2.15mm	6
L04	0C05687A	Clutch Washer	2
L05	0C05707A	Washer 2.15x0.2mm	2
L06	0C05688A	Washer 5.1mm	2
B07	CA05148A	Cassette Well Ass'y 37	1
01	0C05338D	Lid Holder	1
02	0C05336D	Lid Holder Plate R	2
03	0C05373A	Cassette Rubber	1
04	CA05096A	Cassette Spring Ass'y L	1
05	CA05095A	Cassette Spring Ass'y R	1
06	0C05375D	Cassette Case R	1
07	0C05374D	Cassette Case L	1
08	CA05093A	Cassette Well Sub Ass'y	1
09	0H03255D	Tape Illumination Lens	1
10	CA05055A	Well Stopper Ass'y	1
11	0M03403B	Illumination Tape	1
L01	0E00622A	Screw M3x5 Philips Pan Head (2A)	4
L02	0E00251A	Screw M2.6x18 Philips Pan Head	4
L03	0E00026A	Washer 2.6mm Spring	4
L04	0E00222A	E-Ring 2mm	1
B08	CA05145A	Head Base Solenoid Ass'y	1
01	CA05027A	Base Lock Arm Ass'y	1
02	0C05099A	Head Base Solenoid	1
03	CA05041A	Base Damper Holder Ass'y	1
04	CA05133A	Base Damper Ass'y	1
L01	0E00507A	Nut Hex. M3	1
L02	0E00172A	Washer 3mm Toothed Lock	1
L03	0C05098A	Solenoid Bolt	1
L04	0E00612A	Screw M3x6 Philips Pan Head (2A)	2
L05	0E00026A	Washer 2.6mm Spring	2
L06	0E00220A	Screw M2.6x8 Philips Pan Head	2
B09	CA05053A	Brake Solenoid Ass'y	1
01	0C05086B	Brake Solenoid	1
02	0C05087B	Brake Solenoid Spring	1
03	0C05085A	Brake Linkage	1
L01	0C05419A	Brake Bolt	1
L02	0E00233A	Washer 2.6mm Toothed Lock	1
L03	0E00021A	Nut Hex. M2.6	1

10.15. Flywheel Holder Ass'y (B10)

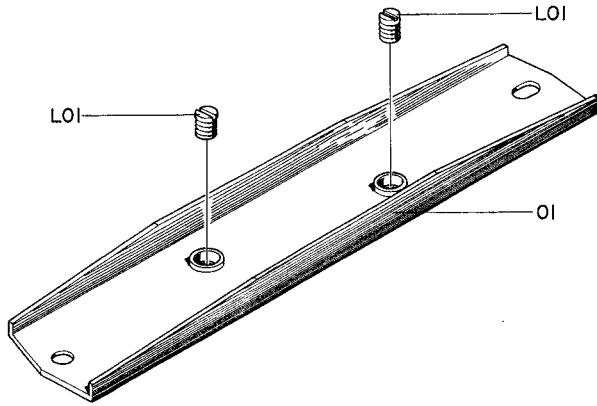

Fig. 10.15

10.16. Capstan Motor Ass'y (B11)

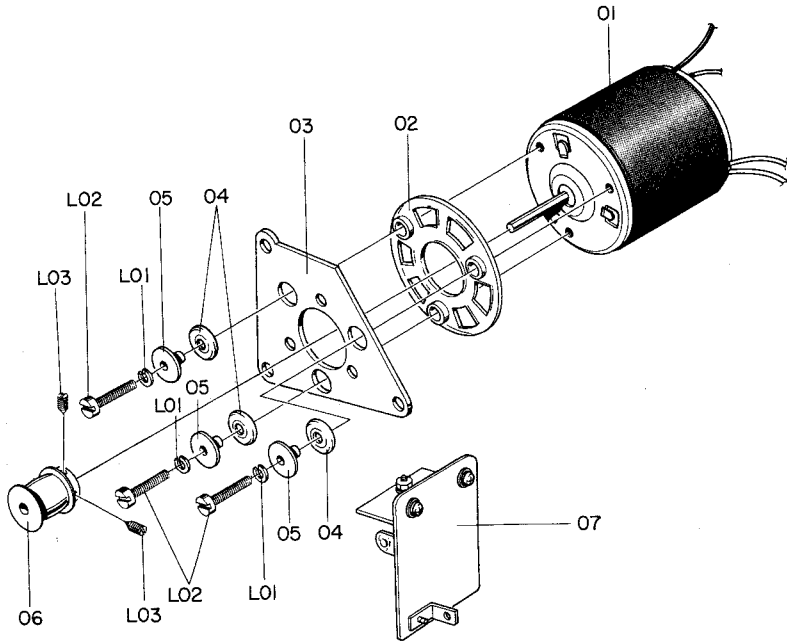

Fig. 10.16

Schematic Ref. No.	Part No.	Description	Q'ty	Schematic Ref. No.	Part No.	Description	Q'ty
B10	CA05171A	Flywheel Holder Ass'y	1	B11	CA05220A	Capstan Motor Ass'y	1
01	CA05008A	Flywheel Holder Sub Ass'y	1	01	CA05203A	Motor NSM-2	1
L01	OC05494B	Thrust	2	02	OC05509A	Floating Sheet	1
				03	OC05198D	Motor Plate	1
				04	OC05510A	Floating Bush	3
				05	OC05508A	Bush Collar	3
				06	OC05671A	Motor Pulley D	1
				07	BA03662B	Capstan Motor Governor	1
						P.C.B. Ass'y	
				L01	0E00025A	Washer 2mm Spring	3
				L02	0E00004A	Screw M2x8 Cylinder Head	3
				L03	0E00626A	Screw M2x3 Cup Point	2

Schematic Ref. No.	Part No.	Description	Q'ty	Schematic Ref. No.	Part No.	Description	Q'ty
B12	CA05134A	Eject Damper Bracket Ass'y	1	C04	CA05174A	Record Head Ass'y	1
01	CA05047A	Eject Damper Ass'y	1	01	GA02007E	Record Head R-52	1
02	0C05135A	Center Guide	2	02	GA01018A	Record Head Plate Ass'y	1
03	0C05232C	Eject Damper Linkage	1	L01	0E00166A	Screw M2x4 Cylinder Head	2
04	CA05068A	Damper Plate Ass'y	1	C05	CA05173B	Playback Head Ass'y	1
05	CA05046A	Damper Plate Holder Ass'y	1				
L01	0E00220A	Screw M2.6x8 Philips Pan Head	2				
L02	0E00026A	Washer 2.6mm Spring	2				
L03	0E00612A	Screw M3x6 Philips Pan Head (2A)	2				
L04	0E00053A	E-Ring 2.3mm	1				
01	GA02013A	Playback Head P-53	1				
02	GA01017A	Playback Head Plate Ass'y	1				
L01	0E00004A	Screw M2x8 Cylinder Head	2				
B13	CA05044A	Cassette Holder Ass'y	1				
01	CA05058A	Cassette Hold Plate Ass'y	1				
02	0C05244B	Linkage Spring	1				
03	CA05059A	Cassette Arm A Ass'y	1				
04	CA05060A	Cassette Arm B Ass'y	1				
05	0C05245C	Hold Spring	1				
06	0C05217B	Hold Roller	1				
L01	0E00222A	E-Ring 2mm	1				
L02	0E00042A	E-Ring 1.5mm	2				
B14	BA03680A	Memory Switch Ass'y	1				
01	0J03219B	Memory Switch Holder B	1				
02	0B07034A	Memory Switch B	1				
L01	0E00025A	Washer 2mm Spring	2				
L02	0E00124A	Screw M2x4 Philips Pan Head	2				
B15	CA05132A	Base Switch Ass'y	1				
01	0C05091A	Base Switch Holder	1				
02	0C05092A	Switch Spring A	1				
03	0B07086A	Micro Switch (SS-5)	1				
04	BA03666A	Head Base Switch P.C.B. Ass'y	1				
L01	0E00218A	Screw M2x10 Cylinder Head	2				
L02	0E00025A	Washer 2mm Spring	2				
C01	CA05208B	Pressure Roller Arm D Ass'y B	1				
01	GA02014A	Erase Head E-54	1				
02	CA05207A	Pressure Roller Arm D Ass'y	1				
L01	0E00117A	Washer 2mm	2				
L02	0E00691A	Screw M2x3 Philips Pan Head	2				
C02	CA05096A	Cassette Spring Ass'y L	1				
01	0C05486A	Cassette Spring Holder L	1				
02	CA05153A	Cassette Spring Ass'y	1				
L01	0E00025A	Washer 2mm Spring	2				
L02	0E00002A	Screw M2x3 Cylinder Head	2				
C03	CA05095A	Cassette Spring Ass'y R	1				
01	0C05487A	Cassette Spring Holder R	1				
02	CA05153A	Cassette Spring Ass'y	1				
L01	0E00025A	Washer 2mm Spring	2				
L02	0E00002A	Screw M2x3 Cylinder Head	2				

10.17. Eject Damper Bracket Ass'y (B12)

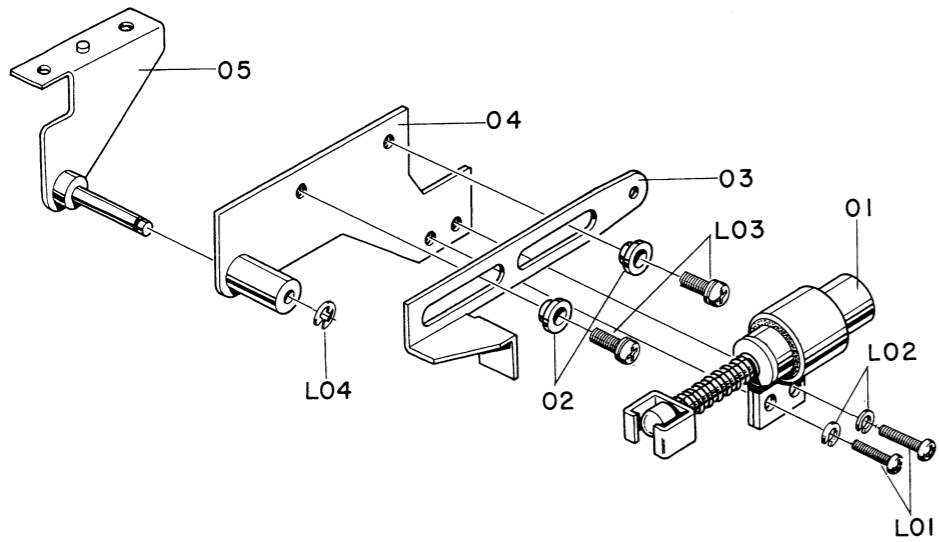

Fig. 10.17

10.18. Cassette Holder Ass'y (B13)

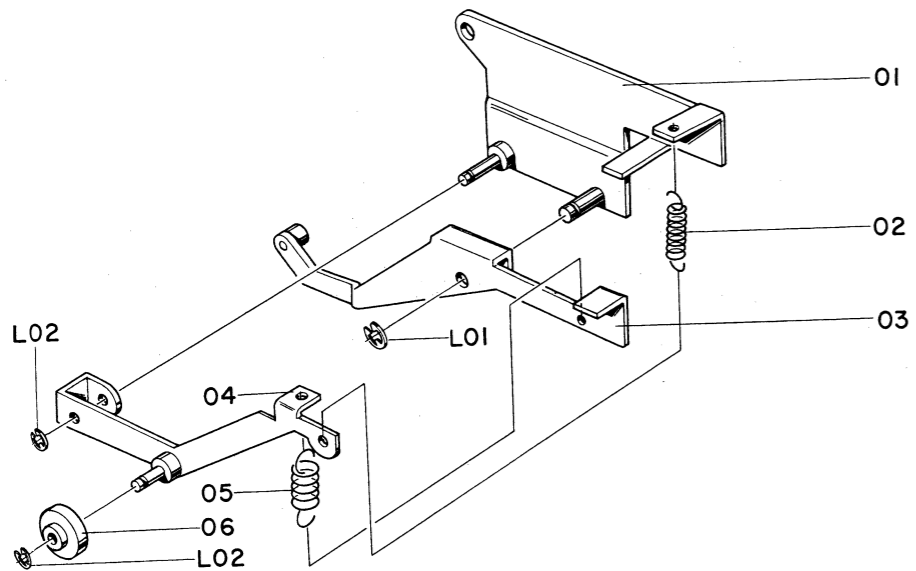

Fig. 10.18

10.19. Memory Switch Ass'y (B14)

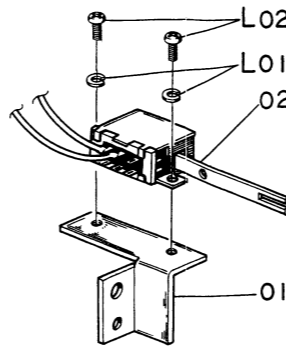

Fig. 10.19

10.20. Base Switch Ass'y (B15)

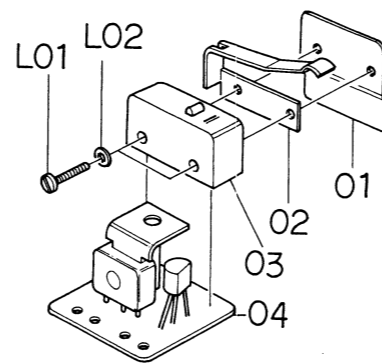

Fig. 10.20

10.21. Pressure Roller Arm D Ass'y B (C01)

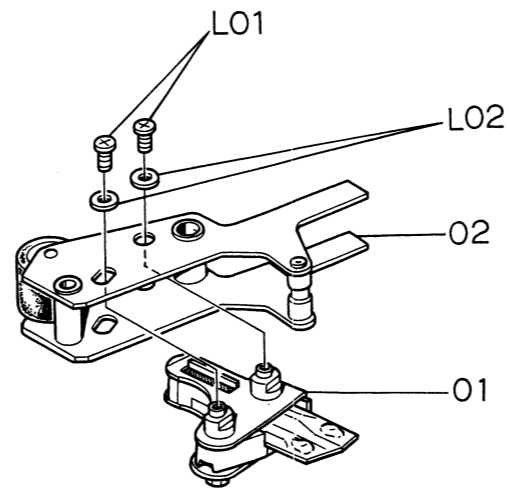

Fig. 10.21

10.22. Cassette Spring Ass'y L (C02)

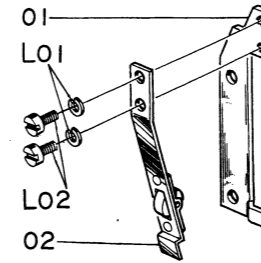

Fig. 10.22

10.23. Cassette Spring Ass'y R (C03)

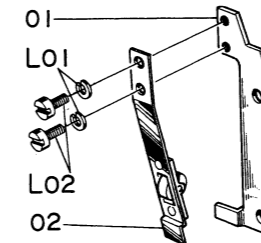

Fig. 10.23

10.24. Record Head Ass'y (C04)

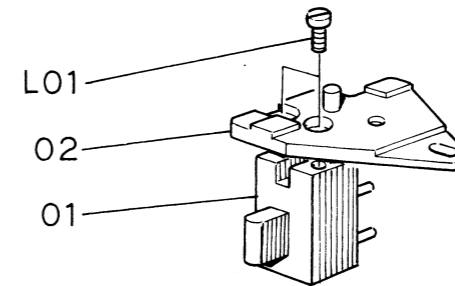

Fig. 10.24

10.25. Playback Head Ass'y (C05)

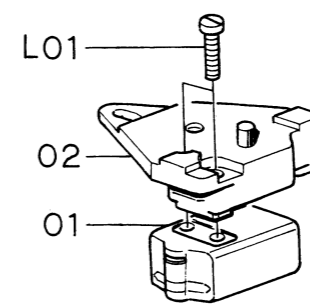

Fig. 10.25

11. WIRING DIAGRAM

11.1. Amplifier

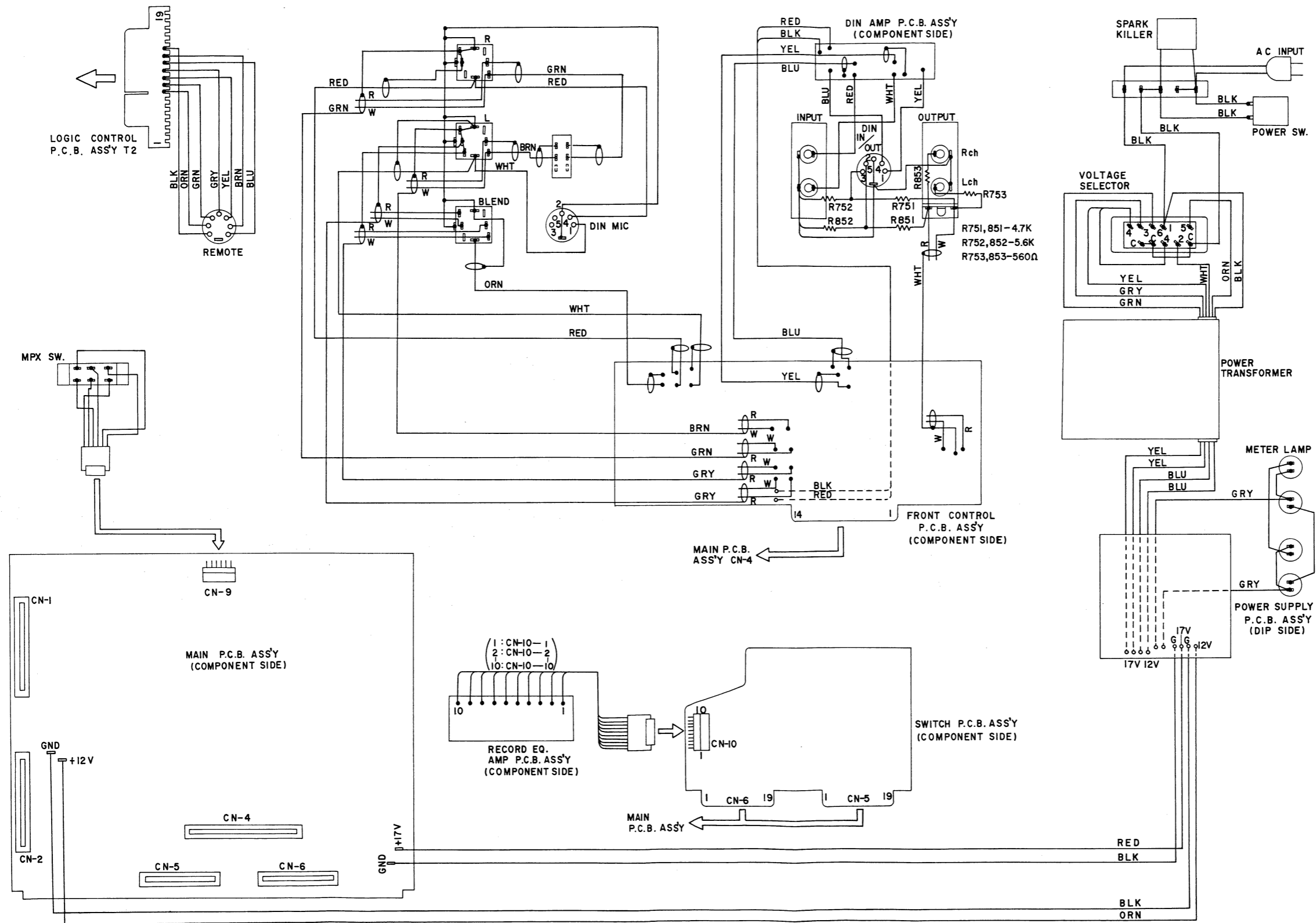

Fig. 11.1

Note: Table of wire colors
 BLK - Black GRY - Gray BRN - Brown
 BLU - Blue GRN - Green YEL - Yellow
 ORN - Orange RED - Red WHT - White

11.2. Mechanism

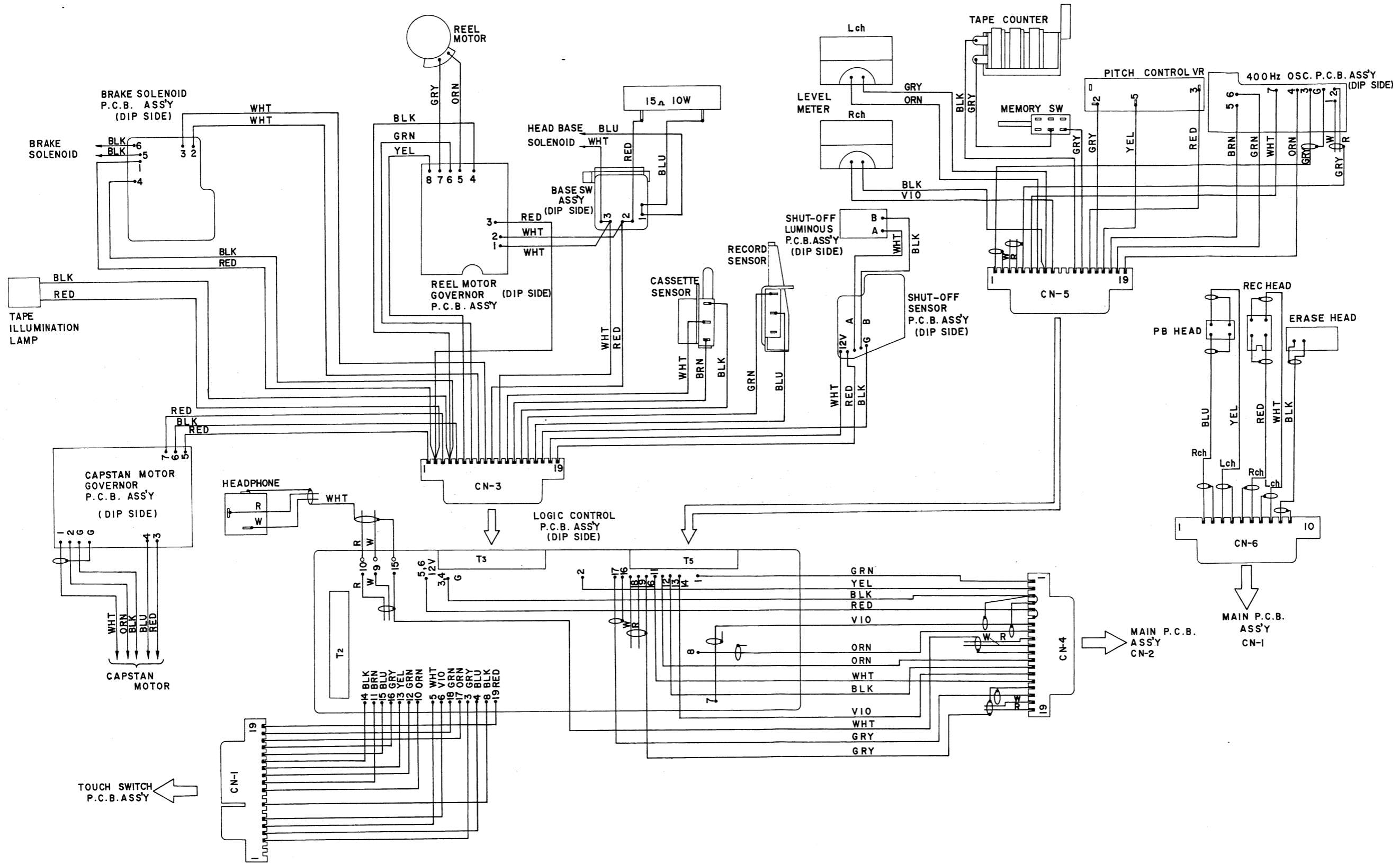

Fig. 11.2

12. BLOCK DIAGRAM

12.1. Amplifier

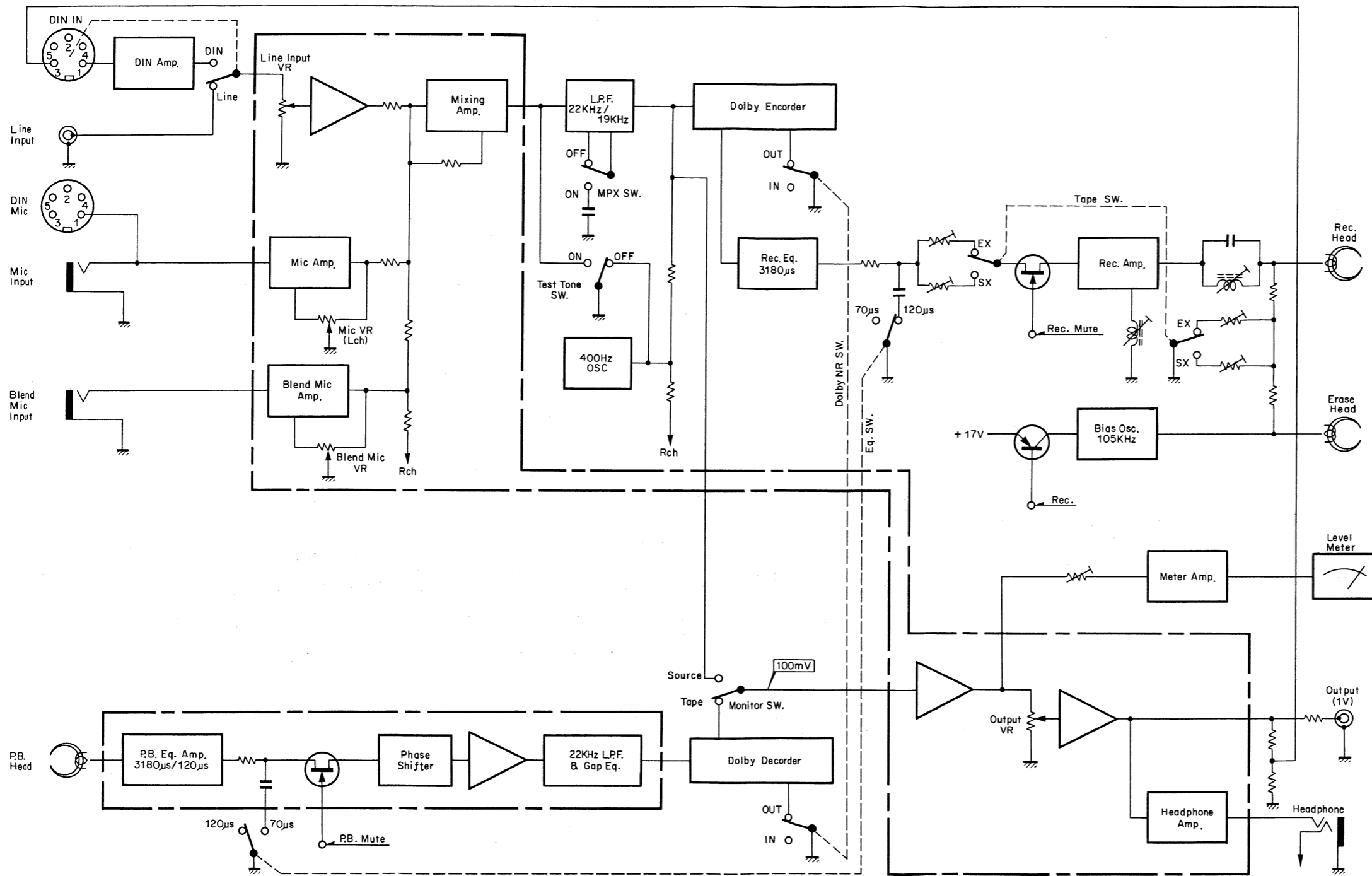

Fig. 12.1

12.2. Mechanism

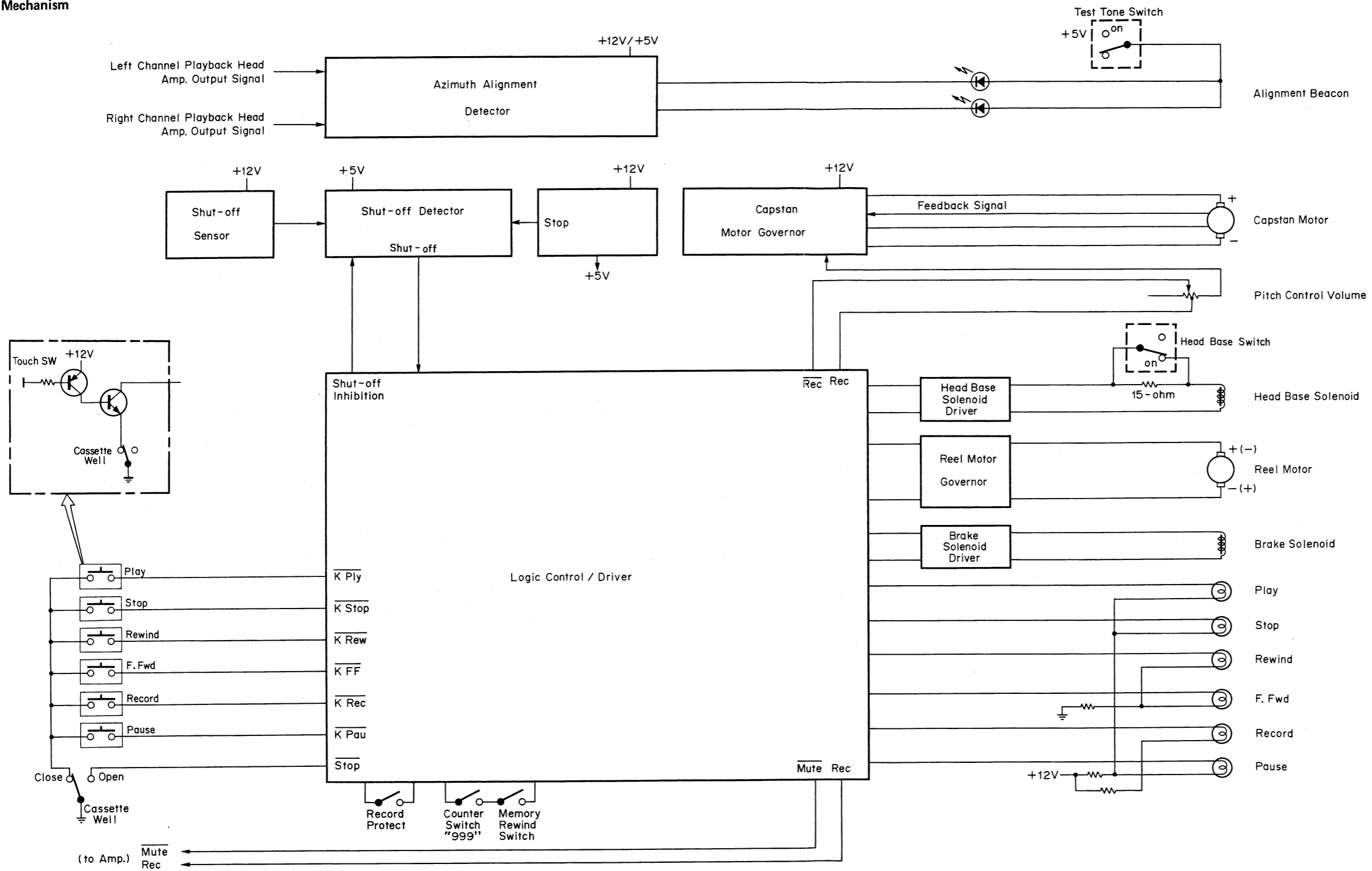

Fig. 12.2

13. LEVEL DIAGRAM

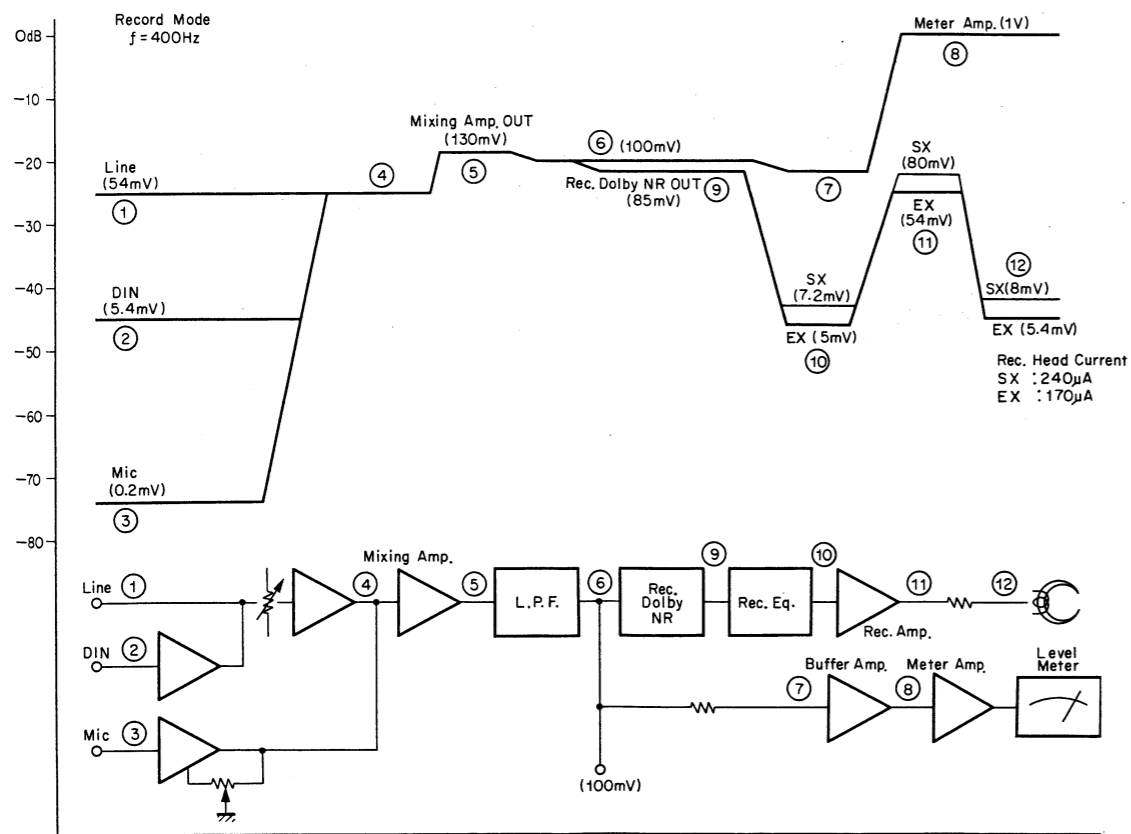
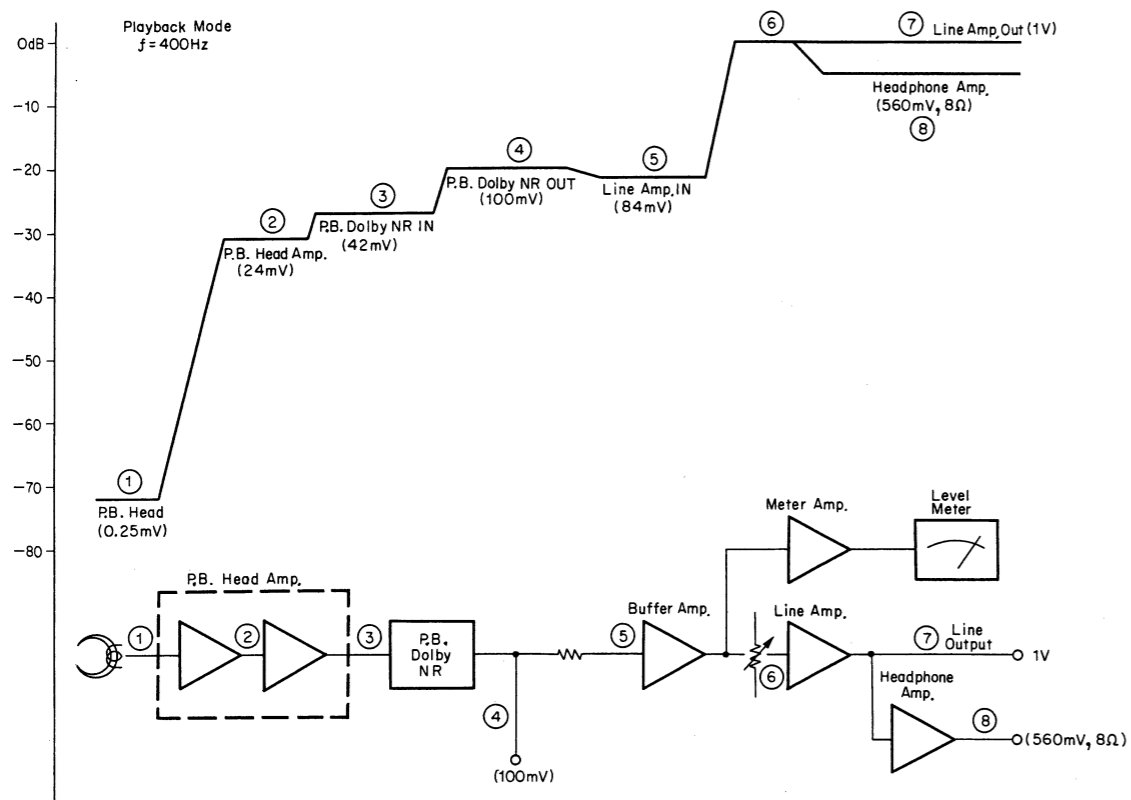

Fig. 13

14. EQ. AMP. FREQUENCY RESPONSE

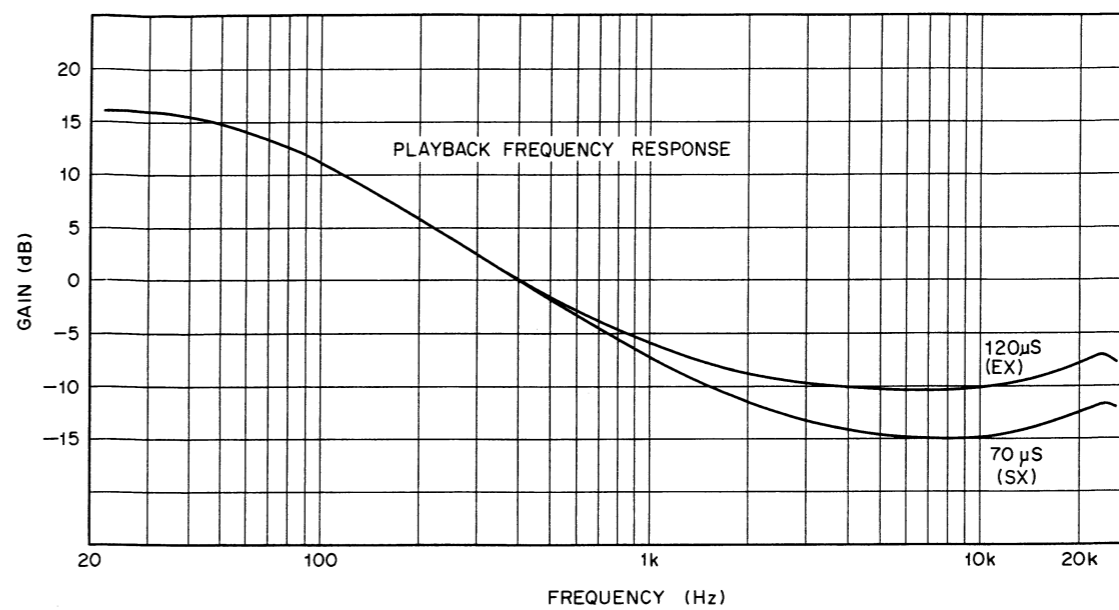

Fig. 14.1

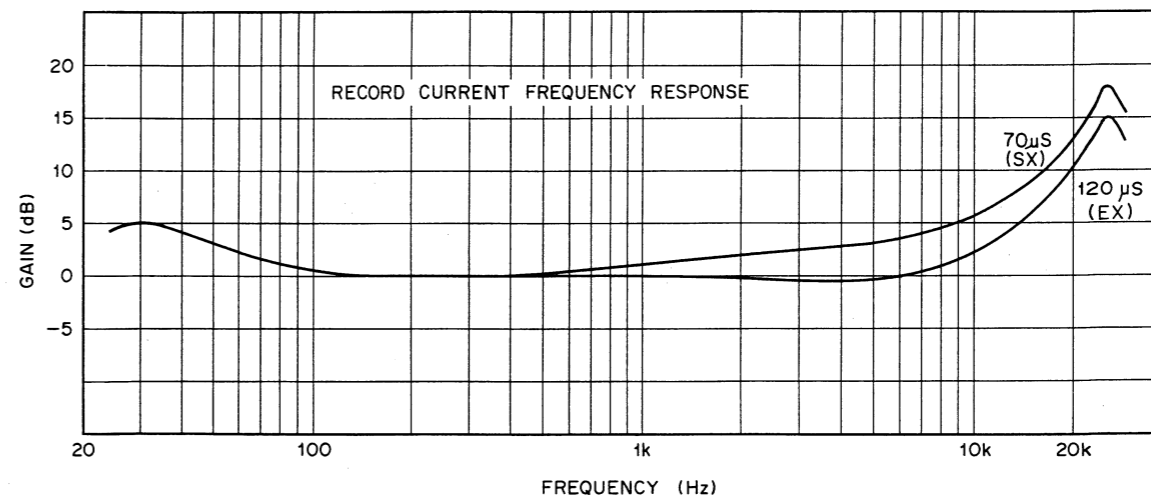
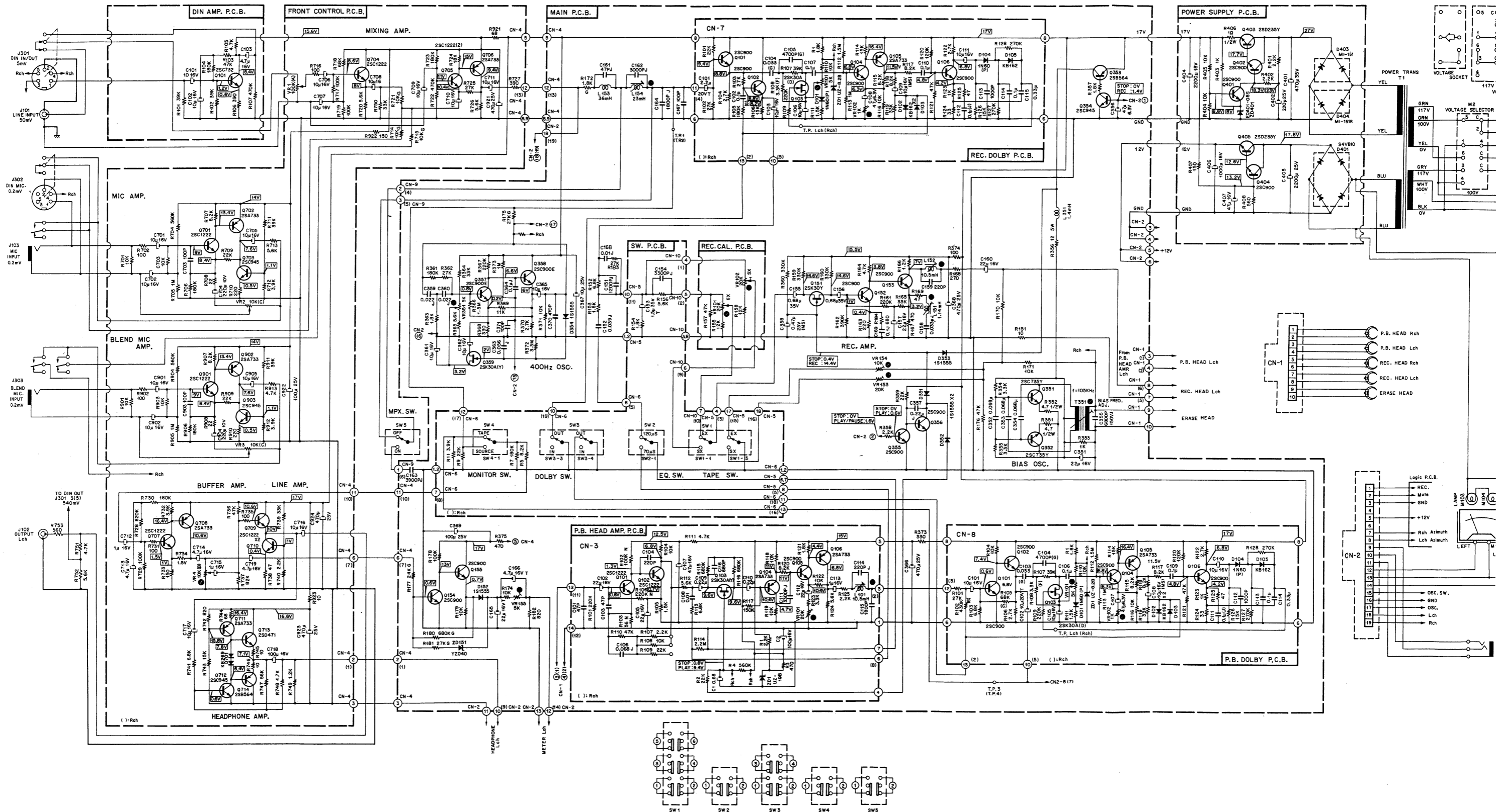

Fig. 14.2

15. SCHEMATIC DIAGRAM

15.1. Amplifier



- Notes: 1. R channel circuits are omitted when R channel circuits equal to the L channel.
 2. Schematic reference Nos. 100-199, 700-799 show L channel's parts and 200-299, 800-899 show R channel's (For example, R101 is an L channel's resistor and omitted R201 is an R channel's).

Fig. 15.1

3. Schematic reference Nos. 300-399, 400-499, 900-999 show common parts for both L and R channels.
 4. () shows an R channel's terminal No.

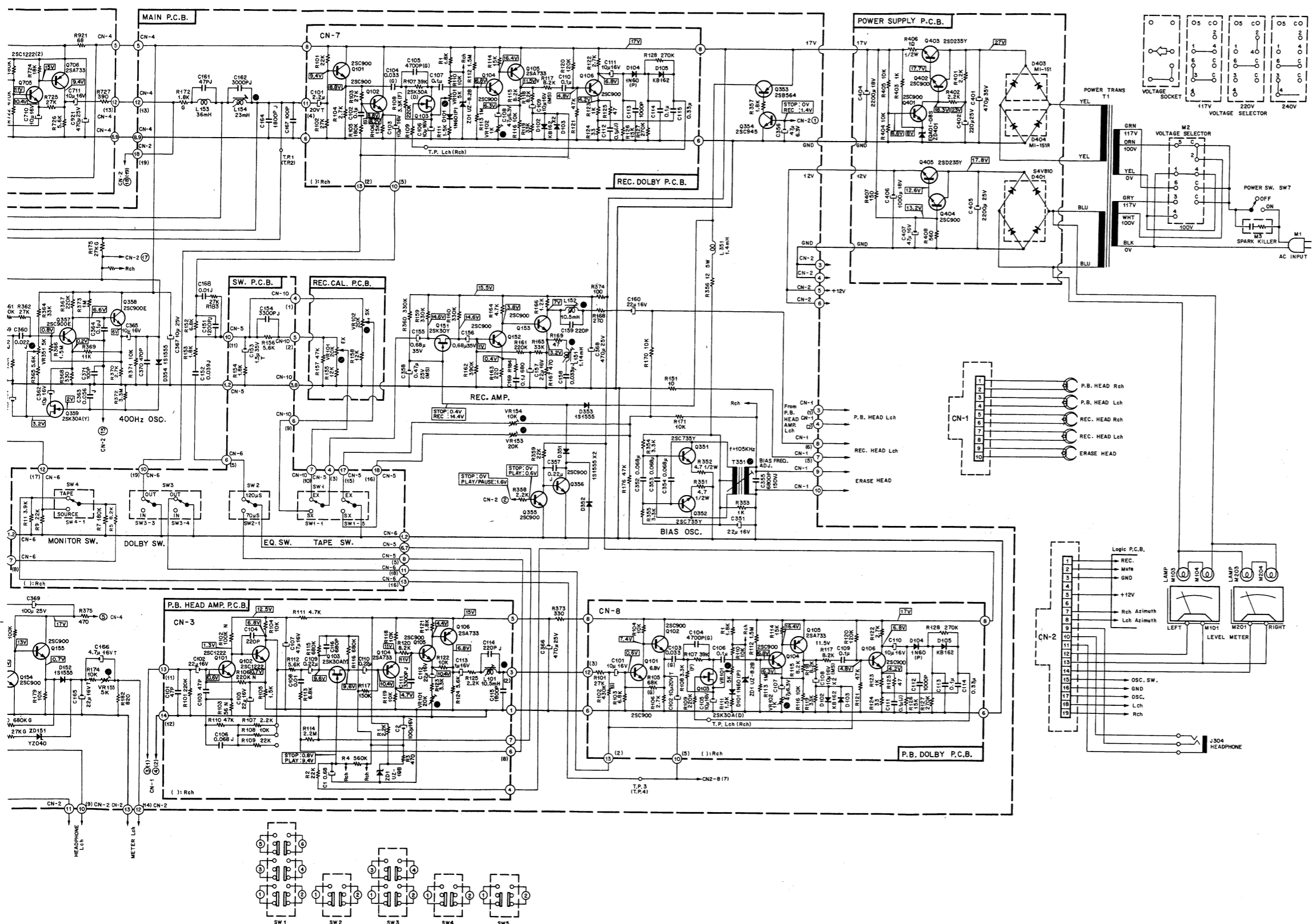

Fig. 15.1

L channel.
 parts and 200-299, 800-899 show R
 d R201 is an R channel's).

3. Schematic reference Nos. 300-399, 400-499, 900-999 show common parts for both L and R channels.
4. () shows an R channel's terminal No.

15.2. Mechanism

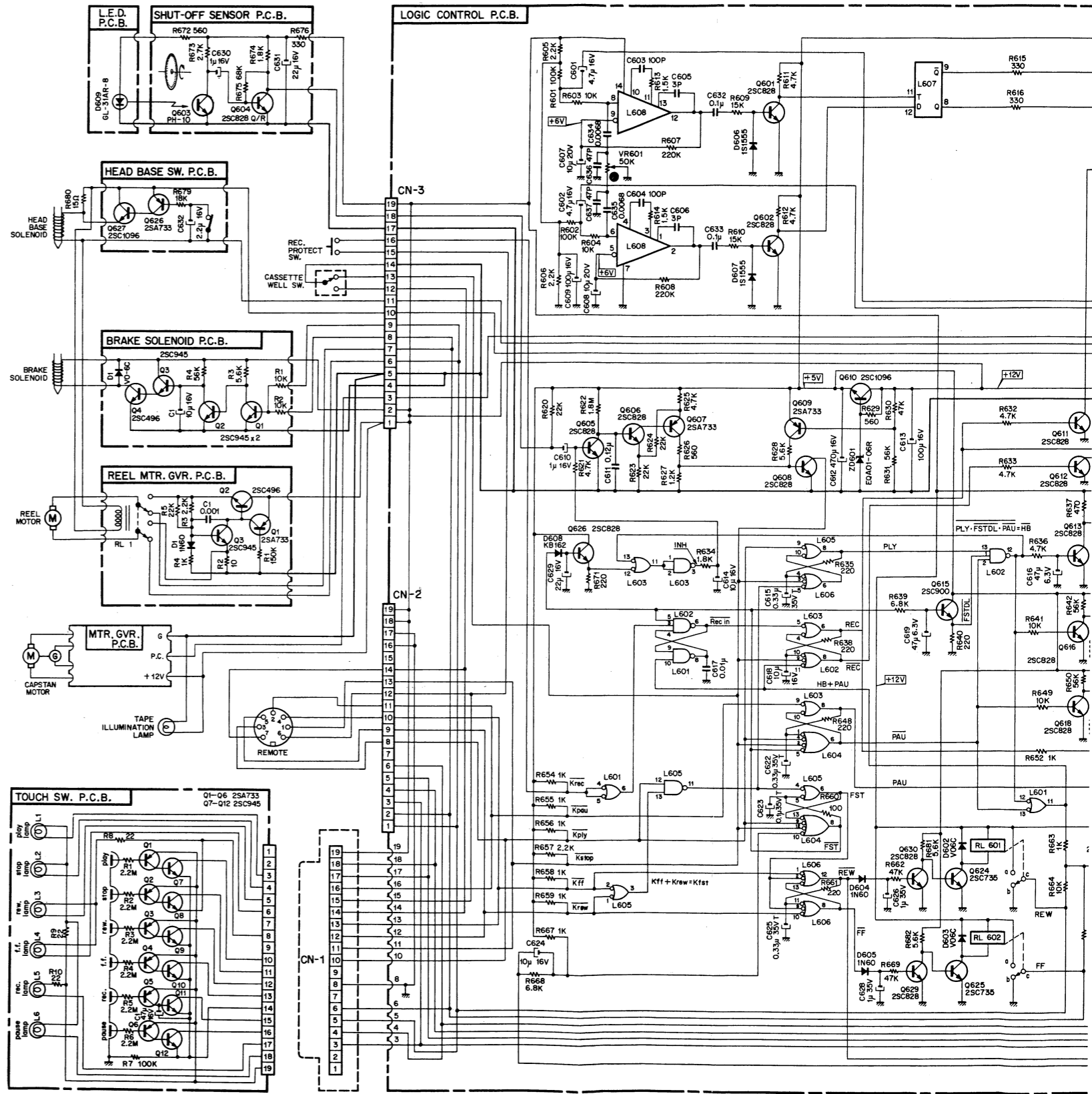

Fig. 15.2

15.2. Mechanism

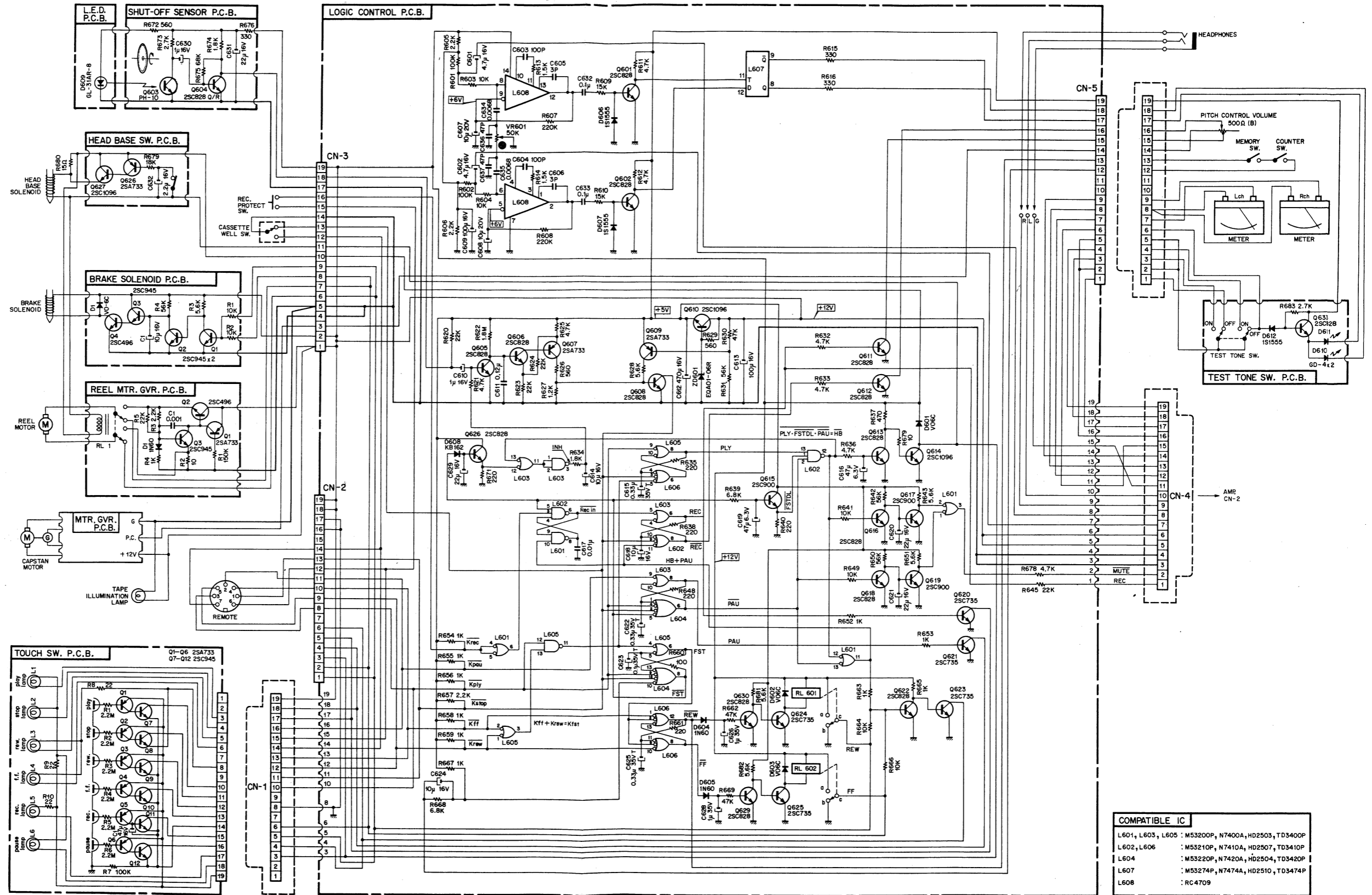

Fig. 15.2

15.3. Capstan Motor Governor

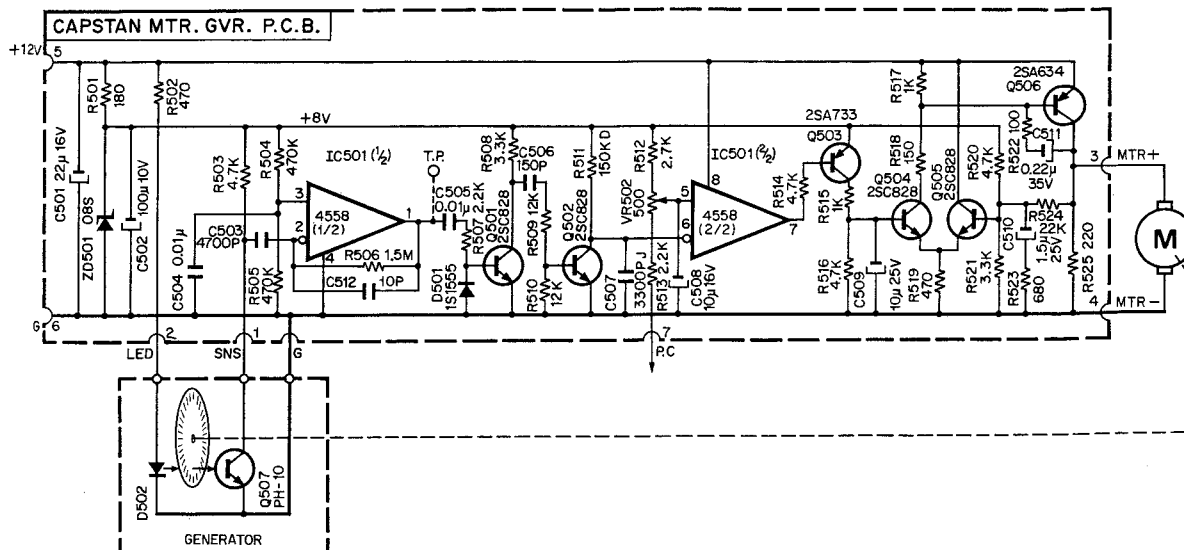

Fig. 15.3

16. TROUBLESHOOTING

16.1. Note

- (1) Check to insure whether the outputs + 12 V, + 17 V and + 5 V of the logic control are correct.
- (2) In general logics, the output high level is not less than 2.4 V, and output low level not more than 0.4–0.5 V.

The output between 0.4–2.4 V does not belong either to "L" or "H", and is generated if TTL IC is damaged or over-loaded (This voltage is called "Half Level").

The threshold level of the TTL IC is shown to be less than 1.1–0.8 V while "L" level, and more than 1.9 V–2.0 V while "H" level.

Normally, if the input is open, it is regarded as high level.

- (3) The logic control board if separated from the chassis does not activate accurately as its grounding is also separated, therefore check thereon shall be made upon connecting the grounding of the PCB control and chassis with a jumper wire both ends of which are provided with a clip (particularly when an extension cord is used).
- (4) When a check is made on Amp. etc. by means of an extension cord, re-adjustment shall be made without fail (after final installation to the model chassis). The check without removal of an extension cord will cause inaccurate adjustments.
- (5) Either Nakamichi SX or EXII tape shall be used while adjustments (particularly while adjustments of bias and record/playback level).

Should another difference branded tape be used in its place, the set shall previously be adjusted according to each of the actual tape in use. However, if low quality tape should be used, optimum quality of a set will not be obtained (such as distortion, S/N, Dynamic Range, etc. will be deteriorated).

16.2. Troubleshoots

16.2.1 Capstan motor does not rotate:

- (1) Defective capstan motor governor.
- (2) Defective capstan motor.
- (3) Pitch control volume is out of accuracy.
- (4) The lead wire between capstan motor governor and capstan motor is cut.
- (5) The lead wire between the governor and pitch control volume is cut.
- (6) + 12 V is not being supplied to the governor.

16.2.2 Auto Shut-off does not work (at tape end):

- (1) One of D403 through D406 is defective (excessive ripple of + 12 V)
- (2) Shut-off driver is defective.
- (3) Shut-off sensor is defective.
- (4) + 12 V regulator is defective (excessive ripple of + 12 V).

16.2.3 Auto Shut-off activates (other than tape end):

- (1) Shut-off belt is cut.
- (2) Shut-off sensor is defective.
- (3) Take-up torque is too weak.
- (4) Defective shut-off driver.
- (5) Pressure roller spring is not at the correct position.

16.2.4 Beacon does not flicker:

- (1) IC 607 is defective.
- (2) IC 608 is defective.
- (3) Defective playback head.
- (4) Defective playback head amp.
- (5) Defective record head.
- (6) Defective beacon LED.
- (7) Tape travel is incorrect.
- (8) Defective Record Eq. Amp.

16.2.5 Does not Shut-off while FF, Rew (at tape end):

- (1) Defective IC603.
- (2) Defective IC604.
- (3) Defective fast driver (in Q626 circuit).

16.2.6. Remained only in Play mode:

- (1) Defective IC605.
- (2) Defective IC606.
- (3) The driver of the head base solenoid is defective.
- (4) Defective touch control switch ass'y.
- (5) Defective head base solenoid.

16.2.7. Remained only in Record mode:

- (1) Defective IC601.
- (2) Defective IC602.
- (3) Defective IC603.
- (4) Defective touch control switch ass'y.

16.2.8 Remained only in Rewind mode:

- (1) Defective touch control switch ass'y.
- (2) Defective IC606.
- (3) Either RL 601 or driver is defective.

16.2.9. Remained only in Fast Forward mode:

- (1) Defective touch control switch ass'y.
- (2) Defective IC606.
- (3) Either RL 602 or driver is defective.

16.2.10. Remained only Pause mode:

- (1) Defective IC601.
- (2) Defective IC603.
- (3) Defective IC604.
- (4) Defective touch control switch ass'y.

16.2.11. Does not change to Play mode:

- (1) Defective touch control switch Ass'y.
- (2) Defective IC605.
- (3) Defective IC606.
- (4) Head base solenoid and driver are defective.
- (5) Auto shut-off driver is defective.
- (6) Head base is not operating accurately (when heavy).
- (7) Ball drive mechanism is not operating accurately.
- (8) Defective take-up reel.
- (9) Defective cassette tape (hard to rotate, etc.).
- (10) Pressure roller spring is out of the correct position.

16.2.12. Does not change to Record mode:

- (1) Touch control switch ass'y is not operating accurately.
- (2) Defective record protect switch.
- (3) Defective IC601.
- (4) Defective IC602.
- (5) Defective IC603.

16.2.13. Does not rewind:

- (1) Touch control switch ass'y is not operating accurately.
- (2) Defective IC606.
- (3) RL601 and driver are defective.
- (4) Defective reel motor.
- (5) Pulley of the reel motor is too loose.
- (6) Defective ball drive mechanism ass'y.
- (7) RL602 and driver are defective.
- (8) Defective brake solenoid driver.
- (9) Defective brake solenoid.

16.2.14. Does not Fast Wind:

- (1) Defective touch control switch ass'y.
- (2) Defective IC606.
- (3) RL602 and driver are defective.
- (4) Defective reel motor.
- (5) Pulley of the reel motor is too loose.
- (6) Defective ball drive mechanism ass'y.
- (7) RL602 and driver are defective.
- (8) Brake solenoid driver is defective.
- (9) Defective brake solenoid.

16.2.15. Does not pause:

- (1) Touch control switch ass'y is defective.
- (2) Defective IC603.
- (3) Defective IC604.
- (4) Defective IC602.
- (5) Head base solenoid and driver are defective.

16.2.16. Brake does not operate:

- (1) Defective solenoid.
- (2) Defective solenoid driver.
- (3) Defective IC606.
- (4) RL601 and driver are defective.
- (5) RL602 and driver are defective.

16.2.17. Head base solenoid does not operate:

- (1) Defective head base solenoid.
- (2) Defective head base switch ass'y.
- (3) Defective solenoid driver.
- (4) Defective IC602.
- (5) Defective IC605.
- (6) Defective IC606.
- (7) Head base is not operating accurately (when heavy).

16.2.18. Record mode operates without cassette tape:

- (1) Incorrect adjustment of record protect switch.
- (2) Defective IC601.
- (3) Defective IC602.
- (4) Defective IC603.

16.2.19. Logic Control does not operate:

- (1) + 5 V not being induced.
- (2) Cassette sensor switch is defective.
- (3) Incorrect adjustment of cassette sensor switch.
- (4) Defective touch control switch ass'y.
- (5) 19P connector is out of contact.

16.2.20. Tape speed is too fast:

- (1) Defective capstan motor.
- (2) Defective capstan motor generator.
- (3) Lead wire of sensor is cut.
- (4) Incorrect adjustment (semi-fixed VR).

16.2.21. Indications Lamp does not light:

- (1) Defective Lamp.
- (2) Lamp Driver is defective.

16.2.22. Does not playback:

- (1) Playback head is defective.
- (2) Defective PB head amp. ass'y.
- (3) Defective PB Dolby NR Ass'y.
- (4) Defective line amp. ass'y.
- (5) Dirty PB head.
- (6) Mute is not operating.
- (7) Wire between playback head and 10P connector is cut.

16.2.23. Does not record:

- (1) Defective record Eq. amp. ass'y.
- (2) Defective record head.
- (3) Defective record Dolby NR Ass'y.
- (4) Bias oscillation is not generating.
- (5) Defective Mic. amp. ass'y.
- (6) Defective 19 kHz MPX filter.
- (7) Incorrect tape travel.
- (8) Either capstan or pressure roller is dirty.
- (9) Dirty playback head.
- (10) Remained only in mute.
- (11) Cut lead wire between record head and 10P connector.
- (12) Defective tape switch.

16.2.24. Bias does not oscillate:

- (1) No voltage to bias oscillation circuit.
- (2) Defective bias oscillation circuit.
- (3) Defective erase head.

16.2.25. Does not erase:

- (1) Defective erase head.
- (2) Dirty erase head.
- (3) Bias is not oscillating.
- (4) Incorrect tape travel.

16.2.26. Level variations:

- (1) Incorrect tape travel.
- (2) Defective pressure roller.
- (3) Variation of take-up torque.
- (4) Defective erase head guide (including incorrect adjustment).
- (5) Dirty capstan or pressure roller.
- (6) Defective flywheel ass'y.
- (7) Incorrect adjustment of pressure roller.
- (8) Record head and playback head are out of correct alignment.
- (9) Defective playback head.
- (10) Defective record head.
- (11) Incorrect adjustment of flywheel thrust screws.

16.2.27. Tape folds:

- (1) Tape guide is in incorrect position.
- (2) Pressure roller is not in the right position against capstan.
- (3) Head mount base is bent.
- (4) Dirty capstan.
- (5) Defective pressure roller.
- (6) Defective cassette tape (non-uniformity of magnetic surface).
- (7) Defective cassette housing.

16.2.28. Unable to secure correct level while record/ playback:

- (1) Distorted.
- (2) Defective record head.
- (3) Defective playback head.
- (4) Defective record eq. amp.
- (5) Defective playback amp.
- (6) Incorrect adjustment of playback head amp.
- (7) Playback head and record head are not in correct alignment.
- (8) Incorrect tape travel.

16.2.29. Great mechanical noise:

- (1) Defective pressure roller.
- (2) Defective ball drive mechanism.
- (3) Defective capstan motor.
- (4) Flywheel is defective.
- (5) Defective counter.
- (6) Defective reel motor.

16.2.30. Sound is distorted:

- (1) Playback head is dirty.
- (2) Record head is dirty.
- (3) Head(s) is(are) magnetized.
- (4) Record head is defective.
- (5) Playback head is defective.
- (6) Bias oscillator circuit is defective.
- (7) Excessive high level at Record/Playback.

16.2.31. Signal to Noise ratio is deteriorated:

- (1) PB Head is magnetized.
- (2) Bias leakage.
- (3) Excessive ripple from power source.
- (4) Either PB head or Rec. Head is defective.
- (5) Defective PB head amp. (Noise level is great).
- (6) Defective record amp. (Noise level is great).

16.2.32. High frequency is deteriorated:

- (1) Misalignment of Record head azimuth.
- (2) Record head is dirty.
- (3) Playback head is dirty.
- (4) Defective Playback head.
- (5) Defective Record head.
- (6) Head(s) is(are) magnetized.
- (7) Incorrect bias adjustment against tape.
- (8) Defective 19 kHz MPX Filter.

16.2.33. Induction of Wow/flutter:

- (1) Defective capstan belt.
- (2) Defective flywheel ass'y.
- (3) Defective capstan flange.
- (4) Defective pressure roller ass'y.
- (5) Defective capstan motor.
- (6) Variation of take-up torque.
- (7) Abnormality of back tension.
- (8) Drive part(s) is(are) dirty.
- (9) Slippage between pressure roller and tape.
- (10) Defective ball drive mechanism ass'y.
- (11) Defective reel motor.

16.2.34. Meters do not flutter:

- (1) Meters themselves are defective.
- (2) Defective meter amp.
- (3) Tape is not played back.
- (4) Neither being recorded nor monitored.
- (5) Meter lead is shorted.
- (6) Meter lead is cut.

16.2.35. No power transmission:

- (1) Defective power cord.
- (2) Defective power switch.
- (3) Defective change-over plug and socket.
- (4) Defective main transformer.
- (5) Defective DC supply circuit.

16.2.36. Ineffective mute:

- (1) No mute signal from logic board.
- (2) Defective mute driver.
- (3) Defective record eq. amp.
- (4) Defective PB Head Amp.

16.2.37. No oscillation of 400 Hz:

- (1) Defective oscillation circuit.
- (2) Defective test tone switch.
- (3) Shorted lead between test tone switch and main P.C.B. ass'y.
- (4) Cut lead between test tone switch and main P.C.B. ass'y.

16.2.38. Tape speed is too slow:

- (1) Defective capstan motor governor.
- (2) Defective capstan motor.

16.2.39. Remained in mute mode:

- (1) Continuous generation of mute signals from logic board.
- (2) Defective mute driver.
- (3) Defective record amp.
- (4) Defective playback head amp.

16.2.40. Defective memory rewind:

- (1) Defective tape counter.
- (2) Defective memory switch.
- (3) Defective driver of memory rewind.

16.2.41. No activation of tape counter:

- (1) Defective tape counter.
- (2) Defective either of counter belt.

16.2.42. Unsatisfactory sound at Dolby NR IN:

- (1) Record/playback level is away from correct level (0 dB).
- (2) Incorrect adjustment of Record Dolby NR.
- (3) Incorrect adjustment of Playback Dolby NR.
- (4) Incorrect bias adjustment against tape.
- (5) Defective Record Dolby NR.
- (6) Defective Playback Dolby NR.
- (7) Incorrect playback level with 400 Hz level tape (DA09005A).

16.2.43. Pneumatic damper ineffective:

- (1) Defective pneumatic damper.
- (2) Defective mechanism (heavy or does not work).
- (3) Incorrect adjustment of damper.

17. SPECIFICATIONS

Power supply	100, 117, 220, 240 V AC 50/60 Hz
Power consumption	60 W Max.
Tape speed	1-7/8 ips. \pm 1%
Wow & flutter	less than 0.1% (DIN 45507 weighted peak playback only) less than 0.05% Wrms
Frequency response	35 - 20,000 Hz \pm 3 dB (Dolby NR in, SX or EXII tape)
Signal to Noise Ratio	better than 65 dB (Dolby NR in, Wrms, IHF-A, 400 Hz, 3% distortion)
Total harmonic distortion	less than 1.5% (at 400 Hz, 0 dB)
Erasure	better than 60 dB (at 1 kHz, saturation level)
Channel separation	better than 35 dB (at 1 kHz, 0 dB)
Cross talk	better than 60 dB (at 1 kHz, 0 dB)
Bias frequency	105 kHz
Input:	
Mic input	0.2 mV 10 k Ω
Blend mic	0.2 mV 10 k Ω
DIN mic input	0.2 mV 10 k Ω
Line	50 mV 50 k Ω
DIN Radio	5 mV 20 k Ω
Output:	
Line	1.0 V (Max.) variable
DIN line output	1.0 V (Max.) variable
Headphones	40 mW/8 Ω (1 kHz, 0 dB)
Transistors	138 pcs.
Diodes	54 pcs.
ICs	9 pcs.
Dimensions	20-11/16" (W) x 10-11/16" (H) x 5-5/8" (D)
Weight	28 lbs approx.

- Specifications and appearance design are subject to change for further improvement without notice.
- Dolby NR under license from Dolby Laboratories.
- The word "DOLBY NR" and the Double-D-Symbol are trademarks of Dolby Laboratories.