

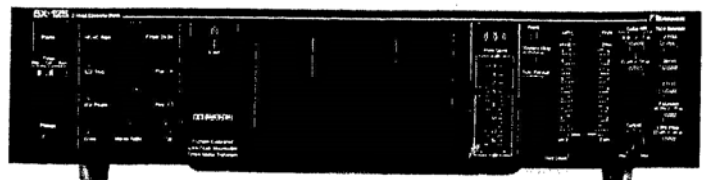

# Service Manual

# Nakamichi BX-125 BX-125E

2 Head Cassette Deck



## CONTENTS

1.	General	1
2.	Test Tapes and Gauges	2
3.	Mechanical Adjustments	2
3. 1.	Tape Guide Height Check for Record/Playback Head and Erase Head	2
3. 2.	Head Base Stroke Check	2
3. 3.	Record/Playback Azimuth Alignment and Height Check	2
3. 4.	Pressure Adjustment of Pressure Roller	3
3. 5.	Tape Travelling Check	3
3. 6.	Eject Damper Adjustment	3
3. 7.	Reel Motor Speed Adjustment in Play Mode	3
3. 8.	Tape Speed Adjustment	3
3. 9.	Lubrication	3
4.	Parts Location for Electrical Adjustment	4
5.	Electrical Adjustments	5
5. 1.	Adjustment Instructions	5
5. 2.	Playback Frequency Response Adjustment	7
6.	Mechanism Ass'y and Parts List	8
6. 1.	Synthesis	8
6. 2.	Synthesis Mechanism Ass'y (A01)	9
6. 3.	Mechanism Ass'y (B01)	11
6. 4.	Rear Panel Ass'y (B02)	13
7.	Mounting Diagrams and Parts List	14
7. 1.	Power Switch P.C.B. Ass'y	14
7. 2.	LED P.C.B. Ass'y	14
7. 3.	Timer Switch P.C.B. Ass'y	14
7. 4.	Shut-off P.C.B. Ass'y	14
7. 5.	Dolby NR Switch P.C.B. Ass'y	15
7. 6.	Volume P.C.B. Ass'y	15
7. 7.	Control Switch P.C.B. Ass'y	15
7. 8.	Tape Switch P.C.B. Ass'y	16
7. 9.	Indicator P.C.B. Ass'y	16
7. 10.	Main P.C.B. Ass'y	17
8.	Schematic Diagram	19
8. 1.	IC Block Diagrams	19
8. 2.	Schematic Diagram	20
9.	Wiring Diagram	21
10.	Block Diagrams	22
11.	Timing Chart and Eq. Amp. Frequency Response	24
12.	Specifications	26

## 1. GENERAL

### 1.1. Voltage Selector

Voltage selector is installed on the rear panel for Other version of the Nakamichi BX-125. This voltage selector can select either 120 V or 220-240 V at customer's disposal.

### 1.2. Packing Materials and Owner's Manual

Part No.	Description	Q'ty
OF03855A	Carton Box BX-125 (Silver)	1
OF03857A	Carton Box BX-125 (Black)	1
OF03856A	Carton Box BX-125E (Silver)	1
OF03858A	Carton Box BX-125E (Black)	1
OF03674C	Packing	2
OD04517A	Owner's Manual (English)	1
OD04518A	Owner's Manual (English/German/French)	1
OD04522A	Owner's Manual (Japanese)	1

### 1.3. Serial Number

The BX-125/BX-125E has two versions, Silver and Black.

In the service manual, serial numbers of these versions are identified as follows:

Silver version: A322xxxxx

Black version: A323xxxxx

However, the actual serial number on the serial number plate of the BX-125/BX-125E is indicated as A322.3xxxxx.

The serial number begins with A322.301001.

## 2. TEST TAPES AND GAUGES

- (1) 400 Hz Level Tape (DA09005B)
- (2) 1 kHz Track Alignment Tape (DA09007B)
- (3) 15 kHz Azimuth Tape (DA09004B)
- (4) 3 kHz Speed and Wow/Flutter Tape (DA09006C)
- (5) 10 kHz PB Frequency Response Tape (DA09003B)
- (6) 15 kHz PB Frequency Response Tape (DA09002B)
- (7) 20 kHz PB Frequency Response Tape (DA09001B)
- (8) Tape Travelling Cassette (DA09027B)
- (9) Reference EXII Tape (DA09066B)
- (10) Reference SX Tape (DA09025B)
- (11) Reference SX-E Tape (DA09086A)
- (12) Reference ZX Tape (DA09037B)
- (13) Head Alignment Gauge (DA09092A)

## 3. MECHANICAL ADJUSTMENTS

### 3.1. Tape Guide Height Check for Record/Playback Head and Erase Head

With use of a Head Alignment Gauge, tape guide height check for the Record/Playback and Erase Heads shall be made, wherein a small block shall be pushed straight down to the base while in use of the Head Alignment Gauge. Refer to Fig. 3.1.

- (1) Record/Playback Head Tape Guide Height
  - (a) Load the base of the Head Alignment Gauge carefully and set the cassette deck in Play mode.
  - (b) Place the small block of the Head Alignment Gauge on the base.
  - (c) Slide the small block against the tape guide of the Record/Playback Head, and check to insure that the block is accepted by the tape guide.
  - (d) If not, loosen the screw and insert a shim (either 30  $\mu\text{m}$  (OC80048A), 60  $\mu\text{m}$  (OC80038A), or 100  $\mu\text{m}$  (OC80039A)) to raise the Record/Playback Head, then tighten and apply a quantity of lock tight paint to the screw.
- (2) Erase Head Tape Guide Height
  - (a) Load the base of the Head Alignment Gauge carefully and set the cassette deck in Play mode.
  - (b) Place the small block of the Head Alignment Gauge on the base.
  - (c) Slide the small block against the tape guide of the Erase Head, and check whether the block is accepted by the tape guide.

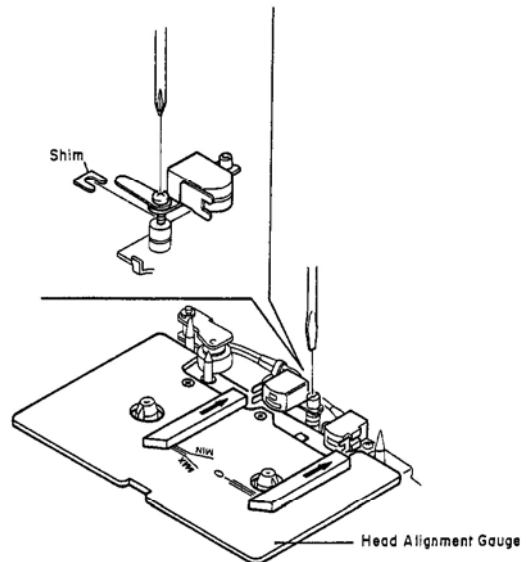

Fig. 3.1

### 3.2. Head Base Stroke Check

Refer to Fig. 3.2.

- (1) Load the base of the Head Alignment Gauge carefully, then push the base toward the Record/Playback Head to eliminate the clearance between the reference pin and the base.
- (2) Set the cassette deck in Play mode.
- (3) Place the small block of the Head Alignment Gauge on the base.
- (4) Contact the small block with the Record/Playback Head surface and the Erase Head surface, and check whether the end of the small block is located within the specified tolerance as shown in Fig. 3.2.

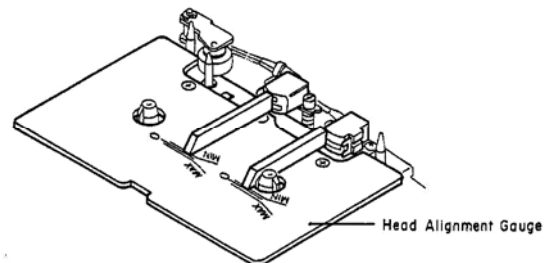

Fig. 3.2

### 3.3. Record/Playback Azimuth Alignment and Height Check

Refer to Fig. 3.1.

- (1) Connect a VTVM to the Output Jacks.
- (2) Load a 15 kHz Azimuth Tape and set the cassette deck in Play mode.
- (3) Turn the Azimuth Alignment Screw until the outputs of both channels become maximum.
- (4) Load a 1 kHz Track Alignment Tape and set the cassette deck in Play mode.
- (5) Check to insure that the readings of both channels on the VTVM are below -25 dB.  
If not, replacement of the Record/Playback Head will be required.
- (6) Apply a quantity of lock tight paint to the Azimuth Alignment Screw.

### 3.4. Pressure Adjustment of Pressure Roller

Refer to Fig. 3.3.

- (1) In Play mode, measure the torque of the Pressure Roller and check whether the torque is in a range of  $320 \pm 50$  g-cm.
- (2) If torque is out of the range, correct it by changing the installation point of the Pressure Roller Spring.

### 3.5. Tape Travelling Check

Load a Tape Travelling Cassette and set the cassette deck in Play mode to check the followings:

- (1) After more than 2 seconds, the fluctuation of the tape travelling on the Record/Playback Head is small.
- (2) Tape is in contact with the head sufficiently.
- (3) Tape waving is small on the heads and pressure roller.

### 3.6. Eject Damper Adjustment

Refer to Fig. 3.4. Load a cassette tape, and with opening the Cassette Case by pressing the Eject button and closing it by hand, adjust the speed of damper action by the Damper Adjustment Screw.

CCW: Damper moves fast.

CW: Damper moves slowly.

### 3.7. Reel Motor Speed Adjustment in Play Mode

- (1) To warm-up the cassette deck, load a C-60 cassette tape and set the cassette deck in Play mode.
- (2) After more than four minutes, load a torque meter TW-211 (made by Sony) and set the cassette deck in Play mode.
- (3) Adjust VR601 on the Main P.C.B. Ass'y to obtain exactly 50 g-cm on the torque meter.

### 3.8. Tape Speed Adjustment

Refer to Fig. 3.5.

- (1) Connect a frequency counter to the Output Jacks.
- (2) Load a 3 kHz Speed and Wow/Flutter Tape and play it back.
- (3) Adjust the Tape Speed Adjustment Volume incorporated in the Capstan Motor to obtain 3,000 Hz on the frequency counter.

CCW: Motor drives slowly.

CW: Motor drives fast.

### 3.9. Lubrication

The tape transport is of a lubrication-free type mechanism. When the following parts are replaced, apply the specified lubricant.

- (1) Molykote (R) Grease (X5-6020)  
Cam Motor Pulley  
Thrust portion on the Capstan Shaft
- (2) FLOIL GB-TS-1  
Washer between Reel Hub Ass'y and Back Tension Spring
- (3) Diamond Oil (EP56)  
Reel Hub Shaft
- (4) Anderol 456  
Capstan Shaft

Note: We suggest that you use the above specified lubricant or equivalent type.

The company dealing in the above lubricant is as follows:

- (a) Molykote (R) Grease (X5-6020)  
Dowcorning Co., Ltd., 1-15-1 Nishishinbashi, Minato-ku, Tokyo, Japan
- (b) FLOIL GB-TS-1  
Kanto Chemicals Co., Ltd., 2-7 Kanda Sakuma-cho, Chiyoda-ku, Tokyo, Japan
- (c) Diamond Oil (EP-56)  
Mitsubishi Oil Co., Ltd., 1-2-4 Toranomon, Minato-ku, Tokyo, Japan
- (d) Anderol 456  
Toyo Kokusai Oil Co., Ltd., 3-3-5 Hatchobori, Chuo-ku, Tokyo, Japan

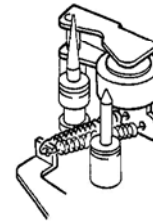

Fig. 3.3

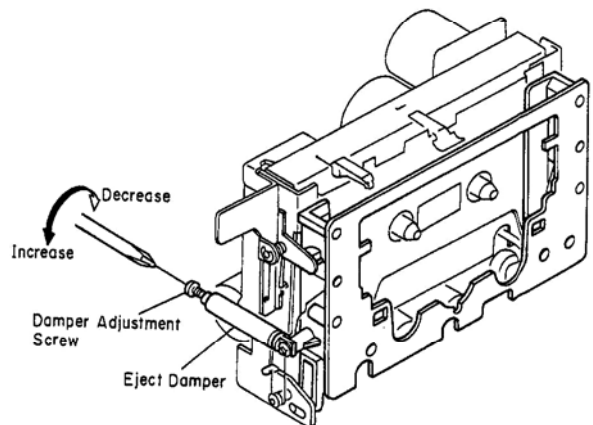

Fig. 3.4

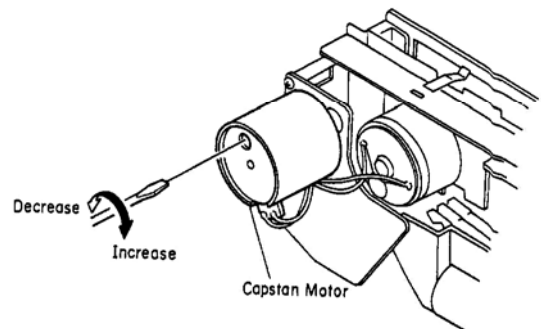

Fig. 3.5

#### 4. PARTS LOCATION FOR ELECTRICAL ADJUSTMENT

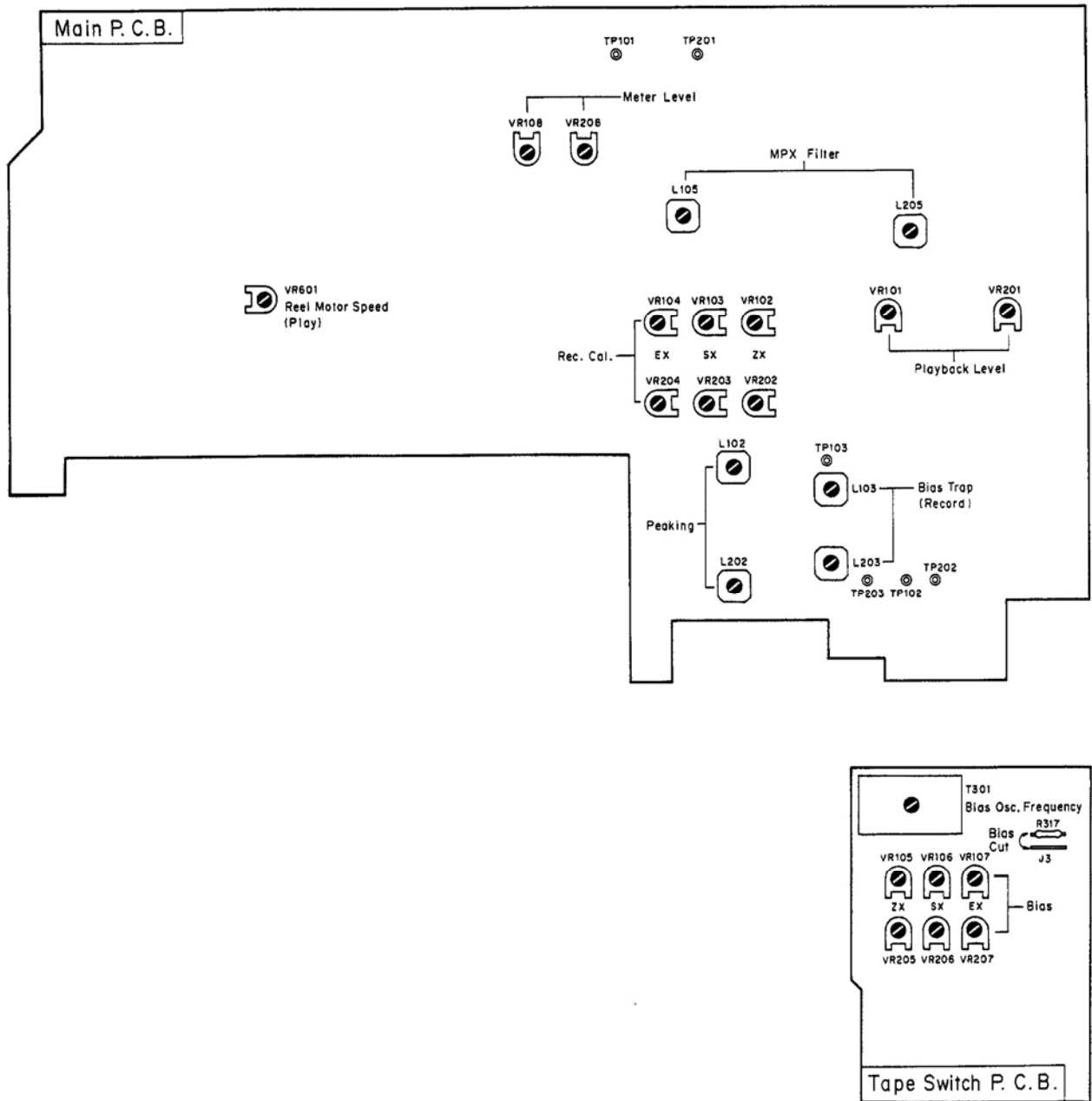

Fig. 4

## 5. ELECTRICAL ADJUSTMENTS

Note: Electrical adjustment should be performed after mechanical adjustment is completed.

### 5.1. Adjustment Instructions

STEP	ITEM	SIGNAL SOURCE	OUTPUT CONNECTION	MODE	ADJUSTMENT	REMARKS
1	Tape Speed Adjustment	3 kHz Speed and Wow/Flutter Tape	Frequency Counter to Output Jacks	Playback Eq. - 70 $\mu$ s	Tape Speed Adjustment Volume	Adjust the volume incorporated in the capstan motor to obtain 3 kHz $\pm 0.5\%$ on the frequency counter.
2	Meter Level Calibration	400 Hz to Input Jacks	VTVM to TP101, TP201 on Main P.C.B.	Record, Pause	Main P.C.B. VR108 VR208	<ol style="list-style-type: none"> <li>1. Feed in 400 Hz and adjust the Input Level controls to obtain 350 mV <math>-0.8</math> dB on the VTVM.</li> <li>2. Adjust VR108 (VR208) so that the 0 dB segment of the level meter starts illuminating.</li> <li>3. Adjust the Input Level controls to obtain 350 mV on the VTVM, then decrease the generator output level by 20 dB.</li> <li>4. Check to insure that the segment for <math>-20</math> dB illuminates.</li> </ol>
3	MPX Filter Adjustment	19 kHz $\pm 100$ Hz to Input Jacks	VTVM to Output Jacks	Record, Pause MPX - OFF/ON	Main P.C.B. L105 L205	<ol style="list-style-type: none"> <li>1. Set the Output Level control to max. Adjust the Input Level controls to obtain 500 mV (0 dB) on the VTVM.</li> <li>2. Set the MPX Filter switch to ON and adjust L105 (L205) to obtain minimum reading on the VTVM (minimum reading will be less than <math>-30</math> dB).</li> </ol>
4	Record/Playback Head Azimuth Alignment	15 kHz Azimuth Tape	VTVM to Output Jacks	Playback Eq. - 70 $\mu$ s Dolby NR - OFF MPX - OFF	Record/Playback Head Azimuth Alignment Screw	Adjust the Record/Playback Head Azimuth Alignment Screw to obtain maximum readings for both channels on the VTVM.
5	Playback Level Calibration	400 Hz Level Tape	VTVM to TP101, TP201 on Main P.C.B.	Same as above	Main P.C.B. VR101 VR201	Adjust VR101 (VR201) to obtain 350 mV on the VTVM.
6	Playback Frequency Response Adjustment	400 Hz Level Tape 10 kHz PB Frequency Response Tape 15 kHz PB Frequency Response Tape 20 kHz PB Frequency Response Tape	VTVM to Output Jacks	Same as above	Main P.C.B. R110 R210  R195 R295	<ol style="list-style-type: none"> <li>1. Load a 400 Hz level tape and play it back. Adjust the Output Level control to a certain level.</li> <li>2. Load 10 kHz, 15 kHz and 20 kHz PB frequency response tapes and play them back. Adjust the record/playback head azimuth to obtain maximum readings for both channels on the VTVM with each tape. Short R110 (R210) or R195 (R295) on the Main P.C.B. Ass'y to obtain the following levels against the level for the 400 Hz level tape. <ul style="list-style-type: none"> <li>10 kHz: <math>-20</math> dB <math>-2</math> to <math>+2</math> dB</li> <li>15 kHz: <math>-20</math> dB <math>-2</math> to <math>+3</math> dB</li> <li>20 kHz: <math>-20</math> dB <math>-2</math> to <math>+4</math> dB</li> </ul> </li> <li>3. Conduct step 4 "Record/Playback Head Azimuth Alignment".</li> </ol>

STEP	ITEM	SIGNAL SOURCE	OUTPUT CONNECTION	MODE	ADJUSTMENT	REMARKS
7	Bias Oscillation Frequency and Erase Current Adjustment	None	Frequency Counter to CN2-2 on Tape Switch P.C.B. and VTVM across the additional 0.1 ohm resistor	Record, Pause Tape - ZX Eq. - 70 $\mu$ s Dolby NR - OFF MPX - OFF	Tape Switch P.C.B. T301 R318 R350	<ol style="list-style-type: none"> <li>1. Connect an additional 0.1 ohm resistor in series to the Erase Head and connect a VTVM across it.</li> <li>2. Adjust T301 to obtain 105 kHz on the frequency counter.</li> <li>3. Check the erase current by the VTVM. Erase current will be in a range of 310 mA to 400 mA (typically approx. 350 mA). If erase current is not sufficient, increase it by shorting either R318 or R350.</li> <li>4. After completion of the erase current adjustment, re-check the bias oscillation frequency.</li> <li>5. Remove the additional 0.1 ohm resistor.</li> </ol>
8	Record Amplifier Equalizer Adjustment	21 kHz (-20 dB) to Input Jacks	VTVM to TP102, TP202 on Main P.C.B.	Same as above	Main P.C.B. L102 L202	<ol style="list-style-type: none"> <li>1. Short the bias cut points indicated in Fig. 4 with a clip to stop bias oscillation.</li> <li>2. Adjust L102 (L202) to obtain peak reading at 21 kHz on the VTVM.</li> <li>3. Remove the clip.</li> </ol>
9	Bias Trap Adjustment (Record Amp.)	None (remove input signals)	VTVM to TP103, TP203 on Main P.C.B.	Same as above	Main P.C.B. L103 L203	Adjust L103 (L203) to obtain maximum reading on the VTVM.
10	Record Level Calibration and Recording Bias Current Adjustment	400 Hz (0 dB) and 15 kHz (-20 dB) to Input Jacks	VTVM and Distortion Meter to Output Jacks	Record and Playback Tape - ZX/SX/EX Eq. - 70 $\mu$ s (ZX/SX) 120 $\mu$ s (EX) Dolby NR - OFF MPX - OFF	Main P.C.B. (Level) ZX: VR102 VR202 SX: VR103 VR203 EX: VR104 VR204  Tape Switch P.C.B. (Bias) ZX: VR105 VR205 SX: VR106 VR206 EX: VR107 VR207	<p>Adjustment should be made in the order of ZX, SX and EX.</p> <ol style="list-style-type: none"> <li>1. Set the Output Level control to max.</li> <li>2. Set the cassette deck in Record/Pause mode.</li> <li>3. Feed in 400 Hz and adjust the Input Level controls to obtain 500 mV (0 dB) on the VTVM.</li> <li>4. Load a reference ZX tape, reference SX/SX-E tape and reference EXII tape.</li> <li>5. Feed in 400 Hz (0 dB) and record, rewind and play it back. Adjust VR102 (VR202) for ZX tape, VR103 (VR203) for SX/SX-E Tape and VR104 (VR204) for EXII tape so that the played back output levels are 500 mV (0 dB) on the VTVM.</li> <li>6. Feed in 15 kHz (-20 dB) and record, rewind and play it back. Adjust VR105 (VR205) for ZX tape, VR106 (VR206) for SX/SX-E tape and VR107 (VR207) for EXII tape so that the played back output levels are 50 mV (-20 dB) on the VTVM.</li> <li>7. Repeat above 5 and 6 two or three times.</li> <li>8. Feed in 400 Hz (0 dB) and record, rewind and play it back. Check to insure whether the total harmonic distortion is less than 1.0% for ZX and EXII tapes and 1.2% for SX/SX-E tape. If the total harmonic distortion exceeds the specified value, repeat above steps till satisfactory results are obtained.</li> </ol>

STEP	ITEM	SIGNAL SOURCE	OUTPUT CONNECTION	MODE	ADJUSTMENT	REMARKS
11	Overall Frequency Response Adjustment	400 Hz (0 dB) and 20 Hz to 17 kHz (-20 dB) to Input Jacks	VTVM to Output Jacks	Record and Playback Tape - ZX/SX/EX Eq. - 70 $\mu$ s (ZX/SX) 120 $\mu$ s (EX) Dolby NR - OFF MPX SW - OFF	Main P.C.B. L102 L202	<ol style="list-style-type: none"> <li>1. Set the cassette deck in Record/Pause mode.</li> <li>2. Feed in 400 Hz and set the Input Level controls to obtain 500 mV (0 dB) on the VTVM.</li> <li>3. Decrease the generator output control by 20 dB.</li> <li>4. Feed in 20 Hz to 17 kHz (-20 dB), and record, rewind and play them back, then check to insure whether the output levels are within -20 dB <math>\pm</math> 4 dB.</li> <li>5. If above is not sufficient, adjust L102 (L202) to obtain approx. -20 dB on the VTVM, then conduct step 10 "Record Level Calibration and Recording Bias Current Adjustment".</li> <li>6. If above is not sufficient, precise re-adjustment of step 6 "Playback Frequency Response", replacement of Record/Playback Head or tape travelling check will be required.</li> </ol>

### 5.2. Playback Frequency Response Adjustment

Figs. 5.1 and 5.2 show the playback amp. circuit for adjustment and the playback equalization curve.

This adjustment will be required if playback level is not sufficient when a 20 kHz PB frequency response tape is played back.

The peaking portion of the equalization curve compensates the gap loss of the playback head. Peaking level is varied by the short circuit of R110 (R210) or R195 (R295).

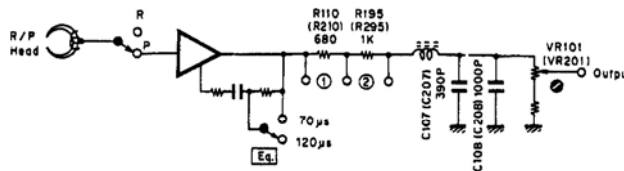

Fig. 5.1

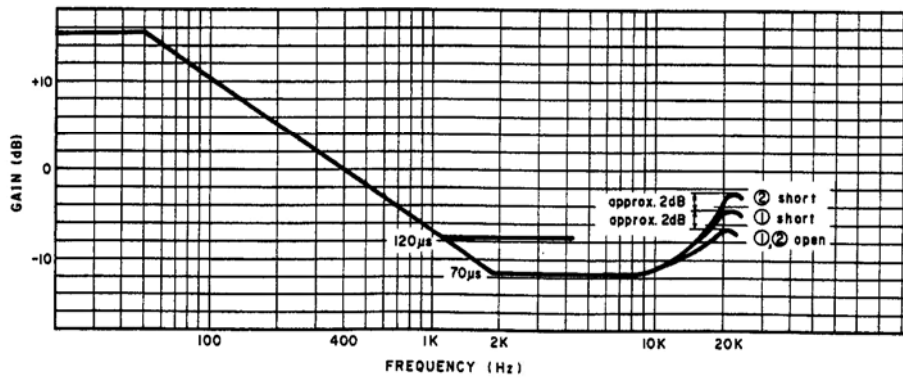

Fig. 5.2



## 6. MECHANISM ASS'Y AND PARTS LIST

### 6.1. Synthesis

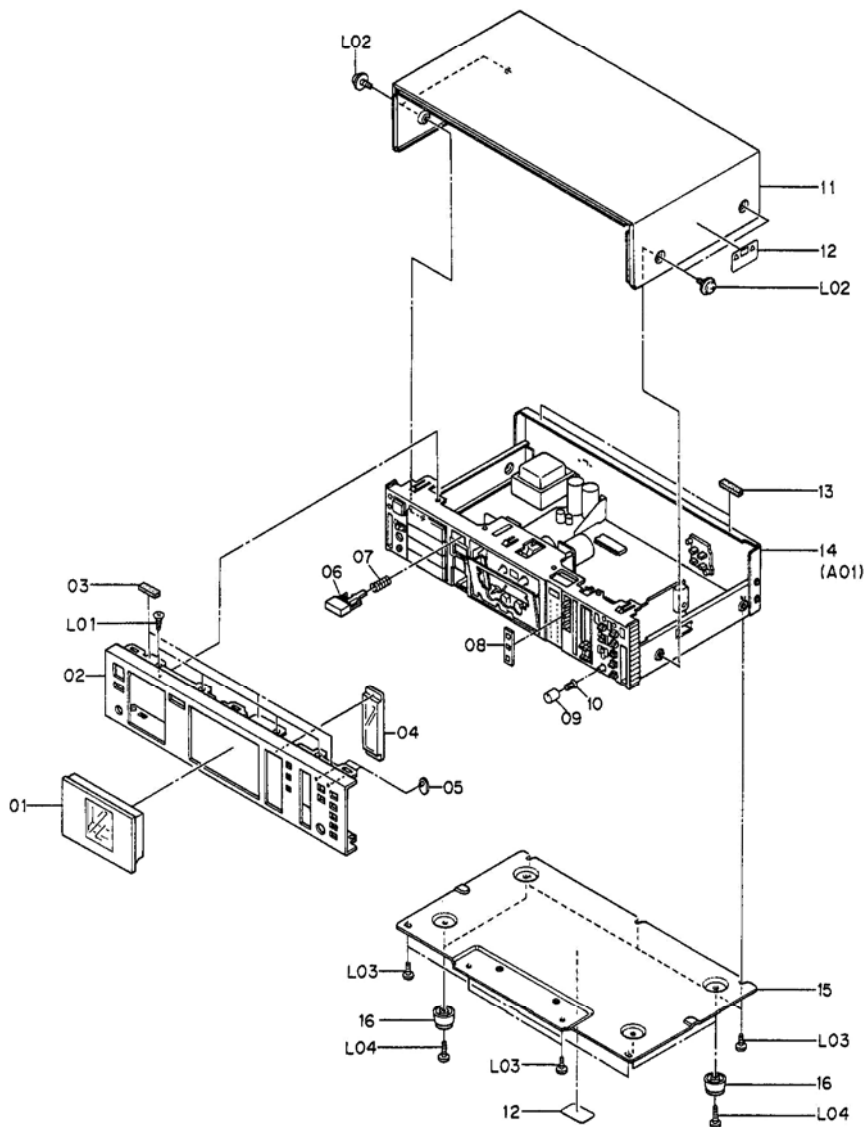

Fig. 6.1

Schematic Ref. No.	Part No.	Description	Q'ty	Schematic Ref. No.	Part No.	Description	Q'ty
		<b>Synthesis</b> Serial No.: A32201001 - (Silver)				<b>Synthesis</b> Serial No.: A32301001 - (Black)	
01	HA04494B	Cassette Case Cover Ass'y	1	01	HA04495B	Cassette Case Cover Ass'y	1
02	OH04582B	Front Panel Ass'y BX-125	1	02	OH04584B	Front Panel Ass'y BX-125	1
	OH04583B	Front Panel Ass'y BX-125E	1		OH04585B	Front Panel Ass'y BX-125E	1
03	OJ04628A	Top Cover Cushion (Front)	3	03	OJ04628A	Top Cover Cushion (Front)	3
04	OH04306A	Meter Cover	1	04	OH04307A	Meter Cover	1
05	OH04240A	LED Lens	2	05	OH04240A	LED Lens	2
06	HA04571A	Eject Button Ass'y	1	06	HA04570A	Eject Button Ass'y	1
07	OJ04765A	Spring	1	07	OJ04765A	Spring	1
08	OH04276A	Counter Escutcheon	1	08	OH04275A	Counter Escutcheon	1
09	OH04432B	Volume Knob	1	09	OH04342A	Volume Knob	1
10	OH03737A	Volume Knob Base	1	10	OH03737A	Volume Knob Base	1
11	OH04155B	Top Cover	1	11	OH04156B	Top Cover	1
12	OM04377B	Caution Label	2	12	OM04377B	Caution Label	2
13	OJ04629A	Top Cover Cushion (Back)	2	13	OJ04629A	Top Cover Cushion (Back)	2
14	—	Synthesis Mechanism Ass'y	1	14	—	Synthesis Mechanism Ass'y	1
15	OJ04762A	Bottom Cover	1	15	OJ04762A	Bottom Cover	1
16	OJ03564A	Leg T-H	4	16	OJ03564A	Leg T-H	4
L01	OE03054A	BT 3x8 @ Countersunk	4	L01	OE03054A	BT 3x8 @ Countersunk	4
L02	OE03033A	BT 4x8 @ Pan Washer-faced (Nickel)	4	L02	OE03032A	BT 4x8 @ Pan Washer-faced (Black Chromate)	4
L03	OE00868A	BT 3x8 @ Binding	7	L03	OE00868A	BT 3x8 @ Binding	7
L04	OE00865A	BT 3x10 @ Binding	4	L04	OE00865A	BT 3x10 @ Binding	4

6.2. Synthesis Mechanism Ass'y (A01)

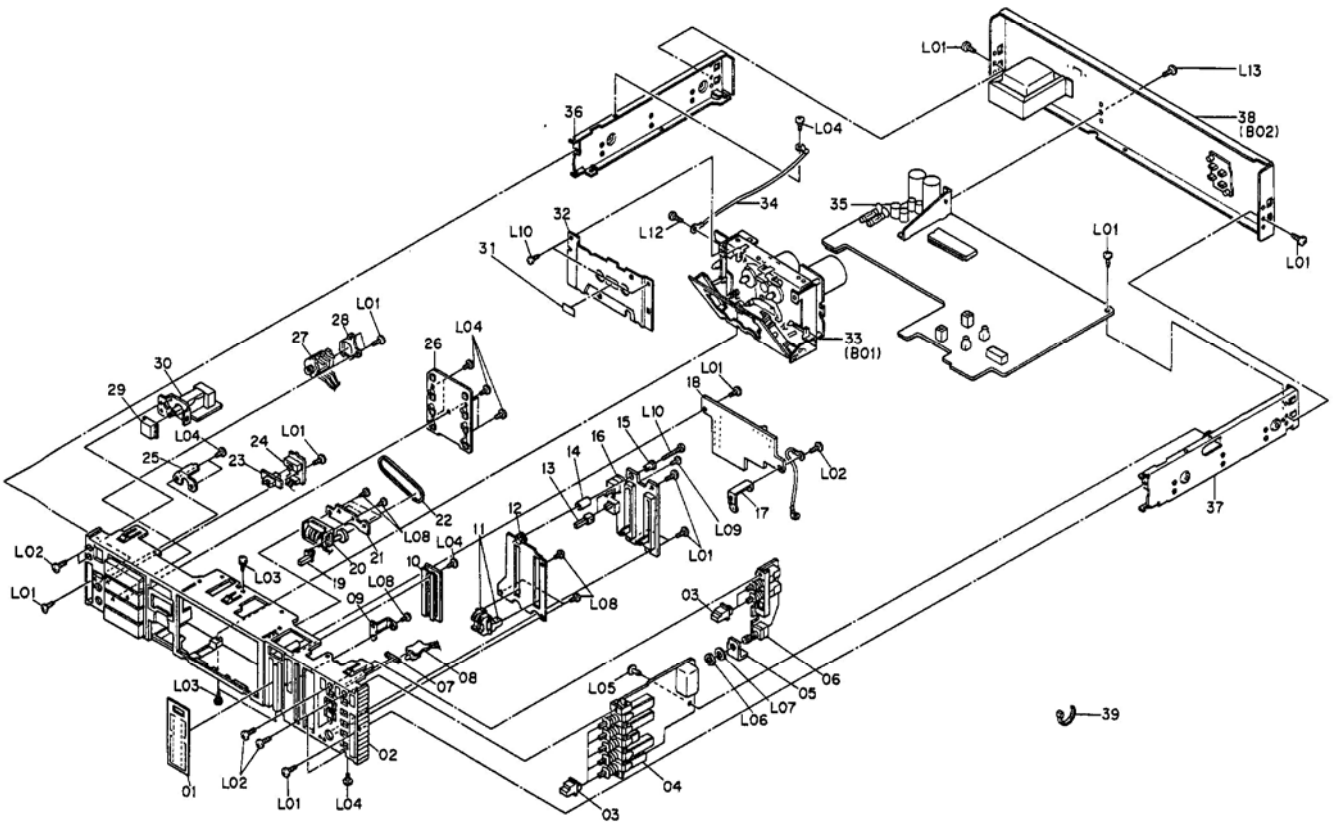

Fig. 6.2

Schematic Ref. No.	Part No.	Description	Q'ty	Schematic Ref. No.	Part No.	Description	Q'ty
A01	—	Synthesis Mechanism Ass'y Serial No.: A32201001 - (Silver)	1	A01	—	Synthesis Mechanism Ass'y Serial No.: A32301001 - (Black)	1
01	OH04277A	Meter Scale	1	01	OH04278B	Meter Scale	1
02	HA04794A	Front Chassis Ass'y	1	02	HA04795A	Front Chassis Ass'y	1
03	OH04288A	Push Switch Button	7	03	OH04248A	Push Switch Button	7
04	BA05637A	Tape Switch P.C.B. Ass'y	1	04	BA05637A	Tape Switch P.C.B. Ass'y	1
05	OJ04838A	Holder	1	05	OJ04838A	Holder	1
06	BA05635A	Dolby NR Switch P.C.B. Ass'y	1	06	BA05635A	Dolby NR Switch P.C.B. Ass'y	1
07	OJ04984A	Cushion A	1	07	OJ04984A	Cushion A	1
08	BA05630A	LED P.C.B. Ass'y	1	08	BA05630A	LED P.C.B. Ass'y	1
09	OJ04767A	Memory Switch Holder	1	09	OJ04767A	Memory Switch Holder	1
10	BA05089A	Indicator Ass'y	1	10	BA05089A	Indicator Ass'y	1
11	OH04289A	Slide Volume Knob	2	11	OH04247B	Slide Volume Knob	2
12	OH04283B	Slide Volume Plate	1	12	OH04284B	Slide Volume Plate	1
13	OH04272A	Memory Switch Knob	2	13	OH04271A	Memory Switch Knob	2
14	OJ04703A	Bushing A	1	14	OJ04703A	Bushing A	1
15	OJ04704A	Bushing B	1	15	OJ04704A	Bushing B	1
16	BA05639A	Volume P.C.B. Ass'y	1	16	BA05639A	Volume P.C.B. Ass'y	1
17	OJ04840A	Indicator P.C.B. Holder	1	17	OJ04840A	Indicator P.C.B. Holder	1
18	BA05638A	Indicator P.C.B. Ass'y	1	18	BA05638A	Indicator P.C.B. Ass'y	1
19	OH04274A	Counter Knob	1	19	OH04273A	Counter Knob	1
20	OC08602A	Tape Counter	1	20	OC08602A	Tape Counter	1
21	OJ04764A	Counter Holder	1	21	OJ04764A	Counter Holder	1
22	OC08604A	Counter Belt	1	22	OC08604A	Counter Belt	1
23	OH04309A	Slide Switch Knob	1	23	OH04242A	Slide Switch Knob	1
24	BA05641A	Timer Switch P.C.B. Ass'y	1	24	BA05641A	Timer Switch P.C.B. Ass'y	1
25	OJ04843A	Timer Switch P.C.B. Holder	1	25	OJ04843A	Timer Switch P.C.B. Holder	1
26	BA05640A	Control Switch P.C.B. Ass'y	1	26	BA05640A	Control Switch P.C.B. Ass'y	1
27	OB08511A	Headphone Jack	1	27	OB08511A	Headphone Jack	1
28	OJ04611A	Headphone Plate	1	28	OJ04611A	Headphone Plate	1
29	OH04290A	Power Switch Button	1	29	OH04243A	Power Switch Button	1
30	BA05230A	Power Switch P.C.B. Ass'y BX-125 (U.S.A. & Canada)	1	30	BA05230A	Power Switch P.C.B. Ass'y BX-125 (U.S.A. & Canada)	1
	BA05231A	Power Switch P.C.B. Ass'y BX-125 (Japan)	1	BA05231A	Power Switch P.C.B. Ass'y BX-125 (Japan)	1	
	BA05229A	Power Switch P.C.B. Ass'y BX-125 (Australia & Others) & BX-125E	1	BA05229A	Power Switch P.C.B. Ass'y BX-125 (Australia & Others) & BX-125E	1	
31	OM04196A	Cassette Label (Silver)	1	31	OM04392A	Cassette Label (Gold)	1
32	OH04154C	Cover Plate	1	32	OH04154C	Cover Plate	1
33	CA08498A	Mechanism Ass'y	1	33	CA08498A	Mechanism Ass'y	1
34	BA05131A	Earth Wire	1	34	BA05131A	Earth Wire	1
35	BA05627A	Main P.C.B. Ass'y BX-125	1	35	BA05627A	Main P.C.B. Ass'y BX-125	1
	BA02757A-E	Main P.C.B. Ass'y BX-125E	1		BA02757A-E	Main P.C.B. Ass'y BX-125E	1
36	OJ04603F	Side Chassis L	1	36	OJ04603F	Side Chassis L	1
37	OJ04773D	Side Chassis R	1	37	OJ04773D	Side Chassis R	1
38	HA04759B	Rear Panel Ass'y BX-125 (U.S.A.)	1	38	HA04764A	Rear Panel Ass'y BX-125 (U.S.A.)	1
	HA04791A	Rear Panel Ass'y BX-125 (Japan)	1		HA04792A	Rear Panel Ass'y BX-125 (Japan)	1
	HA04760A	Rear Panel Ass'y BX-125 (Others)	1		HA04765A	Rear Panel Ass'y BX-125 (Others)	1
	HA04761A	Rear Panel Ass'y BX-125 (Australia)	1		HA04766A	Rear Panel Ass'y BX-125 (Australia)	1
	HA04771B	Rear Panel Ass'y BX-125 (Canada)	1		HA04772A	Rear Panel Ass'y BX-125 (Canada)	1
	HA04758A	Rear Panel Ass'y BX-125E (UK)	1		HA04763A	Rear Panel Ass'y BX-125E (UK)	1
	HA04762A	Rear Panel Ass'y BX-125E (220V Class 2)	1		HA04767A	Rear Panel Ass'y BX-125E (220V Class 2)	1
39	OB08515A	Insu-Lock	14	39	OB08515A	Insu-Lock	14
—	OJ04581A	Counter Cushion	3	—	OJ04581A	Counter Cushion	3
—	OB08525A	Fuse 2A 250V BX-125 (U.S.A., Canada & Others)	2	—	OB08525A	Fuse 2A 250V BX-125 (U.S.A., Canada & Others)	2
—	OB08854A	Fuse 2A BX-125 (Japan)	2	—	OB08854A	Fuse 2A BX-125 (Japan)	2
—	OB08347U	Fuse T1A 250V BX-125 (Australia) & BX-125E	2	—	OB08347U	Fuse 1AT 250V BX-125 (Australia) & BX-125E	2
—	OM04131B	Fuse Label T1A BX-125 (Australia) & BX-125E	1	—	OM04131B	Fuse Label 1AT BX-125 (Australia) & BX-125E	1
—	OB08349B	Fuse Clip BX-125 (Australia) & BX-125E	4	—	OB08349B	Fuse Clip BX-125 (Australia) & BX-125E	4
L01	OE00868A	BT 3x8 @ Binding	15	L01	OE00868A	BT 3x8 @ Binding	15
L02	OE00766A	M3x8 @ Binding	7	L02	OE00766A	M3x8 @ Binding	7
L03	OE03074A	BT 2.6x8 @ Binding with Toothed- Lock Washer	3	L03	OE03074A	BT 2.6x8 @ Binding with Toothed- Lock Washer	3
L04	OE00857A	BT 3x6 @ Binding	10	L04	OE00857A	BT 3x6 @ Binding	10
L05	OB08583A	Plastic Rivet	1	L05	OB08583A	Plastic Rivet	1
L06	—	Nut	(1)	L06	—	Nut	(1)
L07	—	Washer	(1)	L07	—	Washer	(1)
L08	OE00859A	BT 2.6x6 @ Binding	8	L08	OE00859A	BT 2.6x6 @ Binding	8
L09	OE03070A	M2.6x6 @ Binding	1	L09	OE03070A	M2.6x6 @ Binding	1
L10	OE00835A	BT 3x25 @ Pan	1	L10	OE00835A	BT 3x25 @ Pan	1
L11	OE00824A	BT 2.6x6 @ Pan (Black Chromate)	2	L11	OE00824A	BT 2.6x6 @ Pan (Black Chromate)	2
L12	OE00954A	BT 2.6x8 @ Binding	1	L12	OE00954A	BT 2.6x8 @ Binding	1
L13	OE03028A	BT 3x8 @ Binding (Nickel)	1	L13	OE00921A	BT 3x8 @ Binding (Black Chromate)	1

6.3. Mechanism Ass'y (B01)

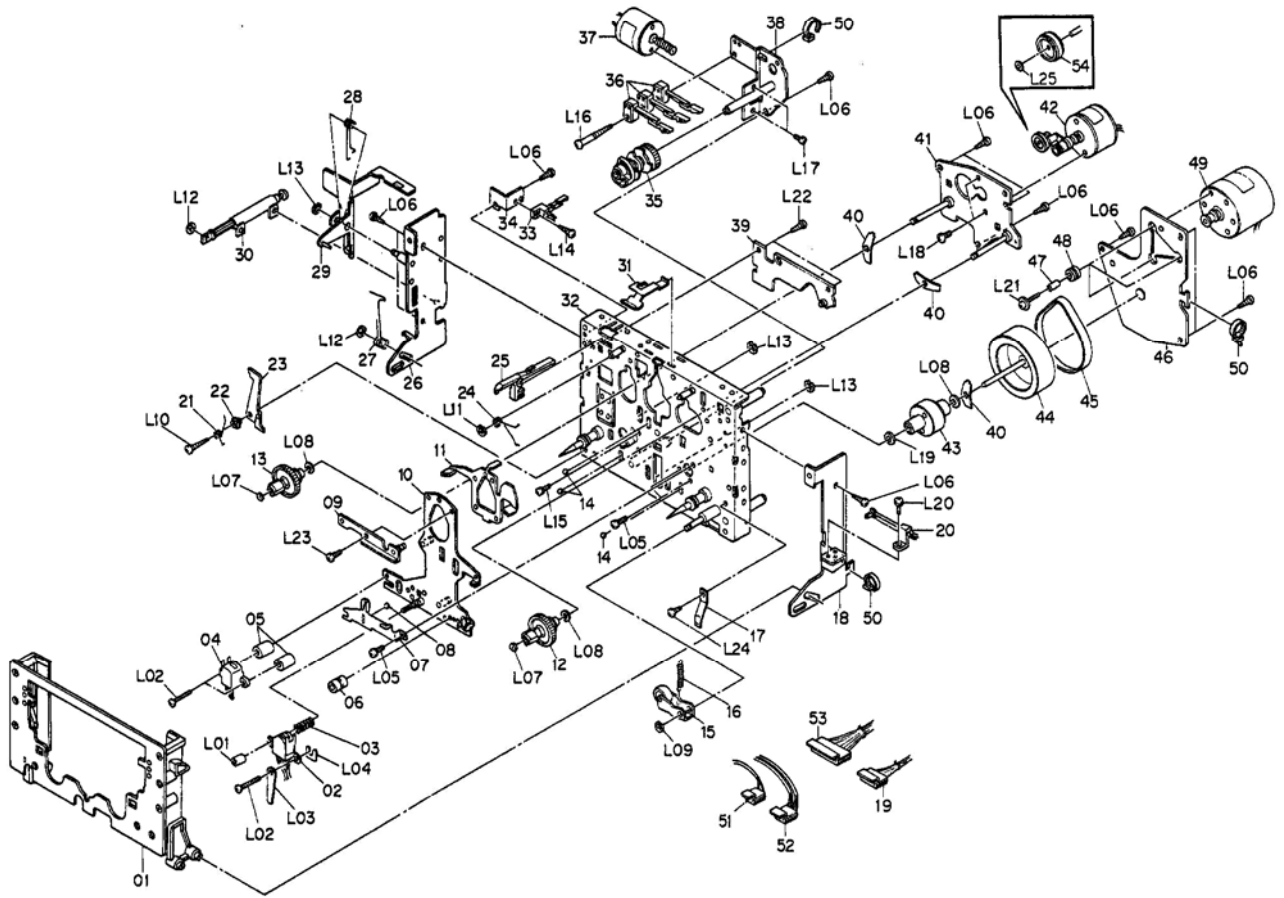

Fig. 6.3

Schematic Ref. No.	Part No.	Description	Qty
<b>B01</b>	<b>CA08498A</b>	<b>Mechanism Ass'y</b> Serial No.: A322.301001 -	<b>1</b>
01	CA80001A	Cassette Case Ass'y	1
02	OG01371A	Record/Playback Head RP-2G	1
03	OC80001A	Azimuth Adjust Spring	1
04	OG01365A	Erase Head E-2D	1
05	OC80044A	Erase Head Collar	2
06	OC80045A	Record/Playback Head Collar	1
07	OC80003A	Head Base Hold Plate	1
08	OC80004A	Steel Ball 3mm	1
09	OC80005A	Reinforcement Plate	1
10	OC80006A	Head Base	1
11	CA80002A	Brake Ass'y	1
12	CA80003B	Take-up Reel Hub Ass'y	1
13	CA80004B	Supply Reel Hub Ass'y	1
14	OC80007A	Steel Ball 2mm	3
15	CA80005A	Pressure Roller Ass'y	1
16	OC80008A	Pressure Roller Spring	1
17	OC80009A	Cassette Case Spring	1
18	OC80010C	Cassette Case Holder R	1
19	OC80043A	5P-H Connector	1
20	OC80012A	Eject Sensor	1
21	OC80013A	Lock Lever Spring	1
22	OC80014A	Lock Lever Collar	1
23	OC80015B	Lock Lever	1
24	OC80016A	Brake Spring	1
25	OC80017A	Record Protector Lever	1
26	OC80018A	Cassette Case Holder L	1
27	OC80019B	Eject Spring	1
28	OC80020A	Eject Lever Spring	1
29	OC80021A	Eject Lever	1
30	CA80006A	Pneumatic Damper Ass'y	1
31	OC80022B	Cassette Hold Spring	1
32	OC80023A	Mechanism Chassis	1
33	OC80024A	Record Protector	1
34	OC80025A	Record Protector Holder	1
35	OC80026A	Cam	1
36	OC80027A	Mode Switch	3
37	CA80007A	Control Motor Ass'y	1
38	OC80028A	Control Motor Holder	1
39	CA80011A	Shut-off P.C.B. Ass'y	1
40	OC80029A	Back Tension Spring	3
41	OC80030A	Reel Motor Holder	1
42	CA80008B	Reel Motor Ass'y	1
43	OC80031A	Capstan Flange	1
44	OC80033A	Flywheel	1
45	OC80034A	Capstan Belt	1
46	CA80009A	Flywheel Holder Ass'y	1
47	OC80035A	Sleeve	3
48	OC80036A	Floating Rubber	3
49	CA80010A	Capstan Motor Ass'y	1
50	OC80037A	Insu-Lock	3
51	OC80040A	2P-H Connector	1
52	OC80041A	4P-H Connector	1
53	OC80042A	9P-H Connector	1
54	OC80635B	Idler Pulley	1
L01	OC80046A	Azimuth Alignment Screw	1
L02	OE03038A	M2x12 @ Binding	3
L03	OE03053A	Wire Holder	1
L04	OC80048A	Shim 0.03T	(1)
	OC80038A	Shim 0.06T	(1)
	OC80039A	Shim 0.1T	(1)
L05	OE03046A	M2.6x6 @ Pan (2A)	3
L06	OE03042A	FT 2.5x5 @ Pan	13
L07	OE03049A	Washer 1.8mm	2
L08	OE03050A	Washer 3.1mm	3
L09	OE00222A	E-Ring 2mm	1
L10	OE03043A	FT 2.5x10 @ Pan	1
L11	OE00698A	E-Ring 2.5mm	1
L12	OE03052A	Stopper Ring 2.4mm	2
L13	OE00181A	E-Ring 3mm	3
L14	OE03048A	FT 2.6x6 @ Pan	1
L15	OE03036A	M2x4 @ Pan (2A)	1
L16	OE03044A	FT 2.5x20 @ Pan	1
L17	OE00691A	M2x3 @ Pan	2
L18	OE03045A	M2.6x3 @ Binding	2
L19	OE03051A	Washer 2.5mm	1
L20	OE03037A	M2x5 @ Pan (2A)	1
L21	OE03047A	M2.6x9 @ Pan	3
L22	OE03041A	FT 2.5x4 @ Pan	2
L23	OE03040A	FT 2.5x3.5 @ Pan	1
L24	OE03035A	M2x3.2 @ Truss	1
L25	OE03245A	Mylar Washer 1.3x3.3x0.3	1

6.4. Rear Panel Ass'y (B02)

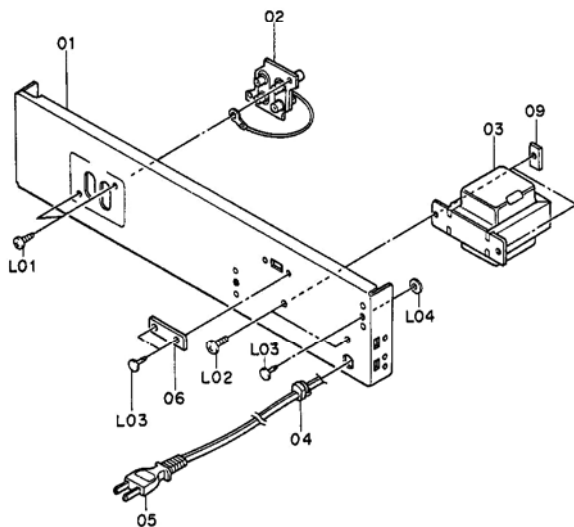
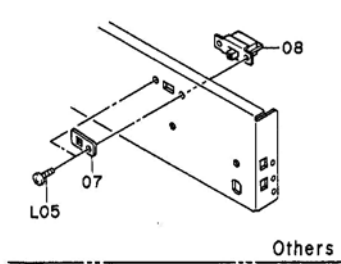

Fig. 6.4

Schematic Ref. No.	Part No.	Description	Q'ty
B02	HA04759B	Rear Panel Ass'y BX-125 (U.S.A.)	1
	HA04771B	Rear Panel Ass'y BX-125 (Canada)	1
	HA04761A	Rear Panel Ass'y BX-125 (Australia)	1
	HA04791A	Rear Panel Ass'y BX-125 (Japan)	1
	HA04760A	Rear Panel Ass'y BX-125 (Others)	1
	HA04758A	Rear Panel Ass'y BX-125E (UK)	1
	HA04762A	Rear Panel Ass'y BX-125E (220V Class 2) Serial No.: A32201001 - (Silver)	1
01	OH04586A	Rear Panel BX-125	1
	OH04587A	Rear Panel BX-125E	1
02	BA05087A	4P Pin Jack Ass'y (Consists of the followings)	1
	(OB81001A)	(4P Pin Jack)	(1)
	(OE00037A)	(Earth Lug)	(1)
03	OB50040A	Power Transformer BX-125 (U.S.A. & Canada)	1
	OB50009B	Power Transformer BX-125 (Australia) & BX-125E	1
	OB50011B	Power Transformer BX-125 (Japan)	1
	OB50010B	Power Transformer BX-125 (Others)	1
04	OB08037U	Cord Bushing C BX-125 (U.S.A., Australia, Others & Japan) & BX-125E (220V Class 2)	1
	OB08351A	Cord Bushing 4K-4 BX-125 (Canada) & BX-125E (UK)	1

Schematic Ref. No.	Part No.	Description	Q'ty	
05	OB08533A	Power Cord BX-125 (U.S.A. & Others)	1	
	OB08504A	Power Cord BX-125 (Canada)	1	
	OB05241A	Power Cord BX-125 (Australia)	1	
	OB08219B	Power Cord BX-125 (Japan)	1	
	OB08348A	Power Cord BX-125E (UK)	1	
	OB08093U	Power Cord BX-125E (220V Class 2)	1	
	06	0J04622B	Switch Cover BX-125 (U.S.A., Canada, Australia & Japan) & BX-125E	1
		07	0M04407A	Voltage Lock Plate BX-125 (Others)
	08	OB07092U	Voltage Selector BX-125 (Others)	1
	09	OC01162B	Bolt Receptacle Plate BX-125 (U.S.A. & Canada)	2
L01	OE03028A	BT 3x8 @ Binding (Nickel)	2	
L02	OE03034A	M4x8 @ Binding (Nickel) BX-125 (U.S.A. & Canada)	2	
	OE00897A	ST 4x8 @ Binding (Nickel) BX-125 (Australia, Others & Japan) & BX-125E	2	
L03	OB08583A	Plastic Rivet	3	
L04	OE00637A	Washer 3.3x7x0.5	1	
L05	OE03031A	M3x8 @ Binding (Nickel) BX-125 (Others)	2	
B02	HA04764A	Rear Panel Ass'y BX-125 (U.S.A.)	1	
	HA04772A	Rear Panel Ass'y BX-125 (Canada)	1	
	HA04766A	Rear Panel Ass'y BX-125 (Australia)	1	
	HA04792A	Rear Panel Ass'y BX-125 (Japan)	1	
	HA04765A	Rear Panel Ass'y BX-125 (Others)	1	
	HA04763A	Rear Panel Ass'y BX-125E (UK)	1	
	HA04767A	Rear Panel Ass'y BX-125E (220V Class 2) Serial No.: A32301001 - (Black)	1	
	01	OH04588A	Rear Panel BX-125	1
		OH04589A	Rear Panel BX-125E	1
	02	BA05087A	4P Pin Jack Ass'y (Consists of the followings)	1
		(OB81001A)	(4P Pin Jack)	(1)
		(OE00037A)	(Earth Lug)	(1)
	03	OB50040A	Power Transformer BX-125 (U.S.A. & Canada)	1
		OB50009B	Power Transformer BX-125 (Australia) & BX-125E	1
		OB50011B	Power Transformer BX-125 (Japan)	1
		OB50010B	Power Transformer BX-125 (Others)	1
	04	OB08037U	Cord Bushing C BX-125 (U.S.A., Australia, Others & Japan) & BX-125E (220V Class 2)	1
		OB08351A	Cord Bushing 4K-4 BX-125 (Canada) & BX-125E (UK)	1
	05	OB08533A	Power Cord BX-125 (U.S.A. & Others)	1
		OB08504A	Power Cord BX-125 (Canada)	1
		OB05241A	Power Cord BX-125 (Australia)	1
		OB08219B	Power Cord BX-125 (Japan)	1
	OB08348A	Power Cord BX-125E (UK)	1	
	OB08093U	Power Cord BX-125E (220V Class 2)	1	
06	0J04601B	Switch Cover BX-125 (U.S.A., Canada, Australia & Japan) & BX-125E	1	
07	0M03948A	Voltage Lock Plate BX-125 (Others)	1	
08	OB07092U	Voltage Selector BX-125 (Others)	1	
09	OC01162B	Bolt Receptacle Plate BX-125 (U.S.A. & Canada)	2	
L01	OE00921A	BT 3x8 @ Binding (Black Chromate)	2	
L02	OE03034A	M4x8 @ Binding (Black Chromate) BX-125 (U.S.A. & Canada)	2	
	OE00907A	ST 4x8 @ Binding (Black Chromate) BX-125 (Australia, Others & Japan) & BX-125E	2	
L03	OB08583A	Plastic Rivet	3	
L04	OE00637A	Washer 3.3x7x0.5	1	
L05	OE00818A	M3x8 @ Binding (Black Chromate) BX-125 (Others)	2	

## 7. MOUNTING DIAGRAMS AND PARTS LIST

- Notes: 1. Mounting diagram shows a dip side view of the printed circuit board.  
 2. Diode is 1SS53, 1S1555, or 1SS176 unless otherwise specified.  
 3. Following transistors are interchangeable with each other.  
 a. 2SA733, 2SA608SP, 2SA1048, 2SA1175  
 b. 2SC945, 2SC536SP, 2SC2458, 2SC2785  
 4. Abbreviation for part name:  
 TR — Transistor, SiD — Silicon Diode, ZD — Zener Diode  
 RK — Carbon Resistor, RM — Metal Film Resistor, RF — Fail Safe Type Resistor  
 CE — Electrolytic Capacitor, CM — Mylar Capacitor, CC — Ceramic Capacitor, CP — PP Capacitor,  
 CT — Tantalum Capacitor, CF — Film Capacitor, C — Mica Capacitor

7.1. Power Switch P.C.B. Ass'y

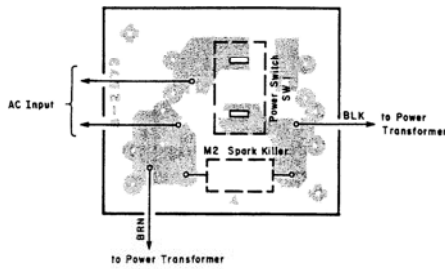

Fig. 7.1

7.3. Timer Switch P.C.B. Ass'y

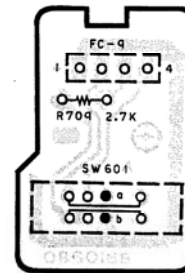

Fig. 7.3

7.2. LED P.C.B. Ass'y

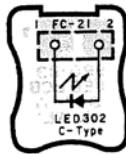

Fig. 7.2

7.4. Shut-off P.C.B. Ass'y

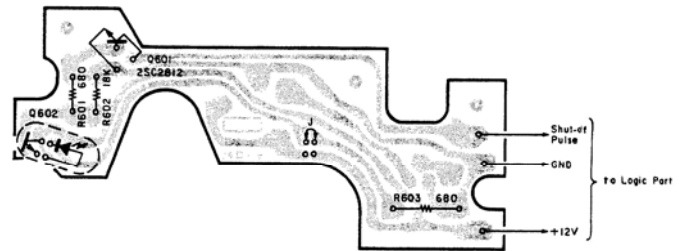

Fig. 7.4

Schematic Ref. No.	Part No.	Description	Schematic Ref. No.	Part No.	Description	Schematic Ref. No.	Part No.	Description
	BA05626A	Set P.C.B. Ass'y BX-125		BA05230A	Power Switch P.C.B. Ass'y BX-125 (U.S.A. & Canada)		BA05641A	Timer Switch P.C.B. Ass'y
	BA05627A	Main P.C.B. Ass'y BX-125		BA05231A	Power Switch P.C.B. Ass'y BX-125 (Japan)	R709 SW601 FC9	OB60189A	Timer Switch P.C.B.
	BA05630A	LED P.C.B. Ass'y		BA05229A	Power Switch P.C.B. Ass'y BX-125 (Australia & Others) & BX-125E		OB09687A	RK 2.7K 1/6W J
	BA05635A	Dolby NR Switch P.C.B. Ass'y					OB07437A	Slide Switch 2-3
	BA05637A	Tape Switch P.C.B. Ass'y		OB02573D	Power Switch P.C.B.		OB81011A	Dip Mate 4P (1)
	BA05638A	Indicator P.C.B. Ass'y	SW1	OB70002A	Power Switch	Q601 Q602	CA80011A	Shut-off P.C.B. Ass'y
	BA05639A	Volume P.C.B. Ass'y	M2	OB08342A	Spark Killer BX-125 (U.S.A. & Canada)		OC80047A	Shut-off P.C.B.
	BA05640A	Control Switch P.C.B. Ass'y	M2	OB08363A	Spark Killer BX-125 (Japan)	R601,603 R602	OB06388A	TR 2SC2812
	BA05641A	Timer Switch P.C.B. Ass'y	M2	OB08445A	Spark Killer BX-125 (Australia & Others) & BX-125E		OB06389A	Photo Reflector NJL5141
	BA05626A-E	Set P.C.B. Ass'y BX-125E		OB90059A	Spark Killer Cover BX-125 (Australia & Others) & BX-125E (1)		OB09840A	RK 680 Leadless
	BA05627A-E	Main P.C.B. Ass'y BX-125E		OB04763A	Power Switch Holder (1)		OB09841A	RK 18K Leadless
	BA05630A	LED P.C.B. Ass'y		OE00612A	M3x6 ⊕ Pan (2A) (2)			
	BA05635A	Dolby NR Switch P.C.B. Ass'y		OE00752A	Eyelet 2x3 (2)			
	BA05637A	Tape Switch P.C.B. Ass'y		BA05630A	LED P.C.B. Ass'y			
	BA05638A	Indicator P.C.B. Ass'y		OB60183A	LED P.C.B.			
	BA05639A	Volume P.C.B. Ass'y		OB06333A	LED Red TLR124A			
	BA05640A	Control Switch P.C.B. Ass'y	LED302	OB81065A	Wire Mate 2P (1)			
	BA05641A	Timer Switch P.C.B. Ass'y		OB82116B	Ribbon Cable 2P (1)			

7.5. Dolby NR Switch P.C.B. Ass'y

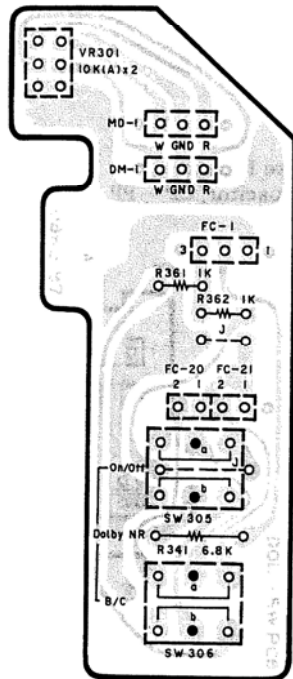

Fig. 7.5

7.6. Volume P.C.B. Ass'y

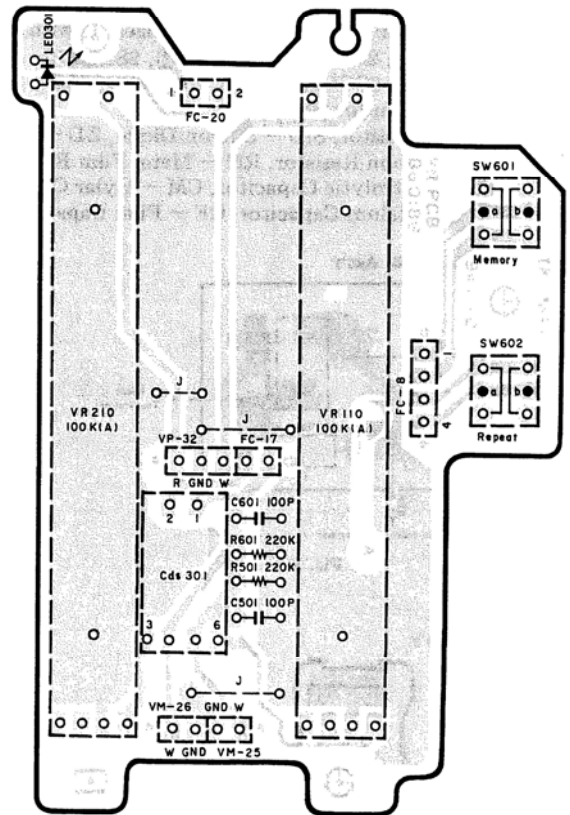

Fig. 7.6

7.7. Control Switch P.C.B. Ass'y

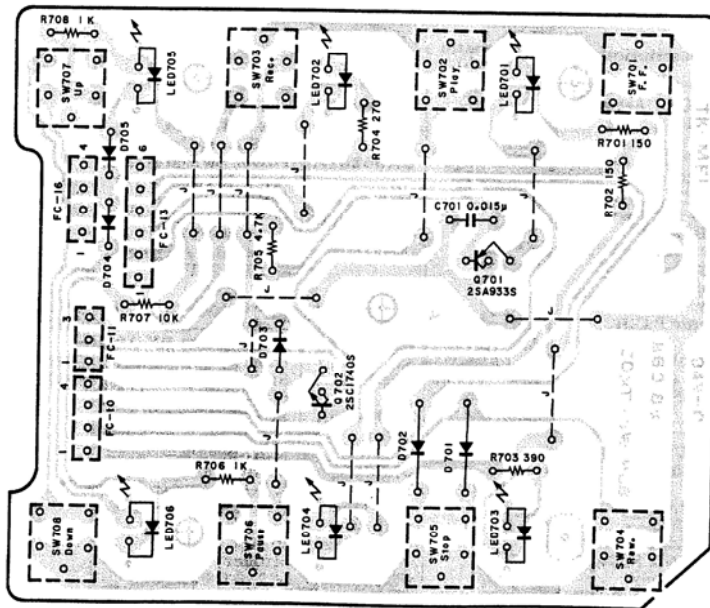

Fig. 7.7



Schematic Ref. No.	Part No.	Description	Schematic Ref. No.	Part No.	Description
BA098394	BA098374	Volume P.C.B. Assy	BA098384	Indicator P.C.B. Assy	
BA098374	BA098374	Dolby NR Switch P.C.B. Assy	08601884	Indicator F.C.B. IC T7A7G12AP	
0860387A	VR 10K (A) x 2		0810313A	IC T7D 2502 (P, Q)	
0860382A	RK 6.8K 1/6W J		0808131A	ZD 2.7V D2.7E	
R341 262	SW70027A	Push Switch 2-Key	0806181A	SID 18S53	
0870027A	FC1M01	Dip Switch 3P	0806398A	SID 18S176 (4)	
FC1M01	0881010A	JP Connector 4P (1)	0801888A	RK 10K 1/6W J	
DM1	0802349A	Volume P.C.B. Assy	0801874	RK 5.6K 1/6W J	
FC20/21	BA098394	Volume P.C.B. Assy	0801874	RK 5.6K 1/6W J	
			0809787A	RK 150 1/6W J	
			R305-314	RK 1.5K 1/6W J (10)	
0860186A	0860186A	Volume P.C.B. LED Red TLR124A	0809817A	RK 1K 1/6W J	
0806339A	0806339A	Photoconductor 214F	0809728A	RK 100K 1/6W J	
0805235B	VR 110 2310	Slide VR 100K (A)	0809709A	RK 22K 1/6W J	
VR110 2310	R301.601	RK 220K 1/6W J	0809688A	RK 2.2K 1/6W J	
R301.601	0809282A	CC 100P 50V K	0809701A	RK 10K 1/6W J	
0809282A	0807462A	Push Switch	0809749A	RK 1.5K 1/6W J	
0807462A	081011A	Dip Switch 4P	RK 47K 1/6W J		
081011A	FC117/FP32	Dip Switch 2P	0809717A	RK 47K 1/6W J	
FC117/FP32	0881012A	Dip Switch 4P (1)	0809281A	CC 180P 50V K	
FC20	0881002A	Dip Switch 2P	C701	CP 0.1u 50V J	
			0809868A	CE 10u 16V (BP)	
BA09840A		Control Switch F.C.B. Assy	0801632A	CE 0.22u 50V J	
			0809111A	Dip Switch 4P	
0860188A	0810026A	Control Switch P.C.B.	0881011A	JP Connector 12P (1)	
0810026A	Q701	TR 2SA933S (Q, R, S)	0802356A	JP Connector 12P (1)	
Q701	Q702	TR (S E) 740S			
0810039A	LED701	LED Green TLR124A			
0806334A	703,704	LED Red TLR124A			
0806334A	705,706	SID 18S176			
LED701	D701,702	SID 18S83			
705,706	D701,702	SID 18S176			
D701,702	705	RK 150 1/6W J			
705	R703	RK 390 1/6W J			
R703	R704	RK 270 1/6W J			
R704	R705	RK 1K 1/6W J			
R705	R706	RK 1.5K 1/6W J			
R706	R707	RK 10K 1/6W J			
R707	R708	CM 0.015u 50V J			
R708	C701	Touch Switch			
C701	SW701-708	LED 4.5mm LED Reflector (6)			
SW701-708	0004744A	Tape Switch P.C.B. Assy			
0004744A	BA09837A	Tape Switch P.C.B. Assy			
BA09837A	0860184A	Temp Switch P.C.B. TLM			
0860184A	0802039A	Semi-fixed VR 22K			
0802039A	208,207	Temp Switch P.C.B. TLM			
208,207	VR108,206	Semi-fixed VR 47K			
VR108,206	R1.38,238	RK 100 1/6W J			
R1.38,238	R1.38,239	RK 5.6K 1/6W J			
R1.38,239	R1.38,232	RK 1.8K 1/6W J			
R1.38,232	R1.40,240	RK 15K 1/6W J			
R1.40,240	R1.97,297	RK 1.5K 1/6W J			
R1.97,297	R817	RK 22K 1/6W J			
R817	R818	RF 10 1W J			
R818	0809283A	CP 220P 50V K			
0809283A	C18,218	CP 8200P 100V J			
C18,218	C308	CE 47u 16V 100V J			
C308	0801403A	CP 500P 100V J			
0801403A	C327	CM 0.047u 50V J			
C327	832	CM 0.047u 50V J			
832	0809187A	2P-S Port			
0809187A	CN2	Dip Switch 4P			
CN2	C333,334	Dip Switch 4P			
C333,334	SM27/28	Dip Switch 3P			
SM27/28	0881012A	Bias Osc. Unit			
0881012A	0806889C	Push Switch 5-Key			
0806889C	0870005A	Earth Plane A			
0870005A					

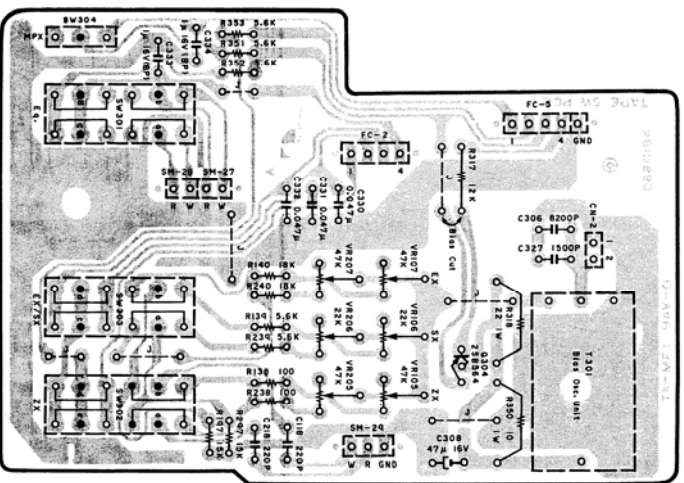

FIG. 7.8

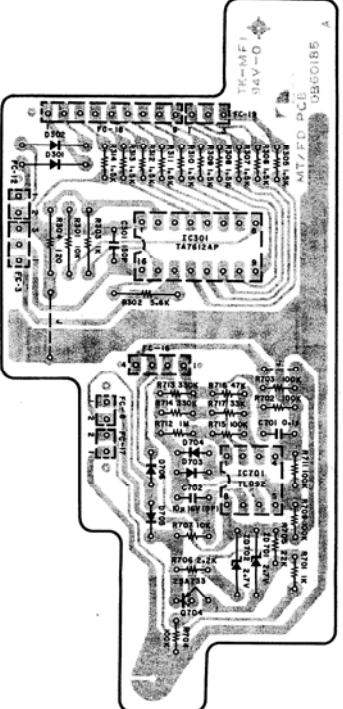

FIG. 7.9

7.8. Tube Switch P.C.B. Assy

7.9. Indicator P.C.B. Assy

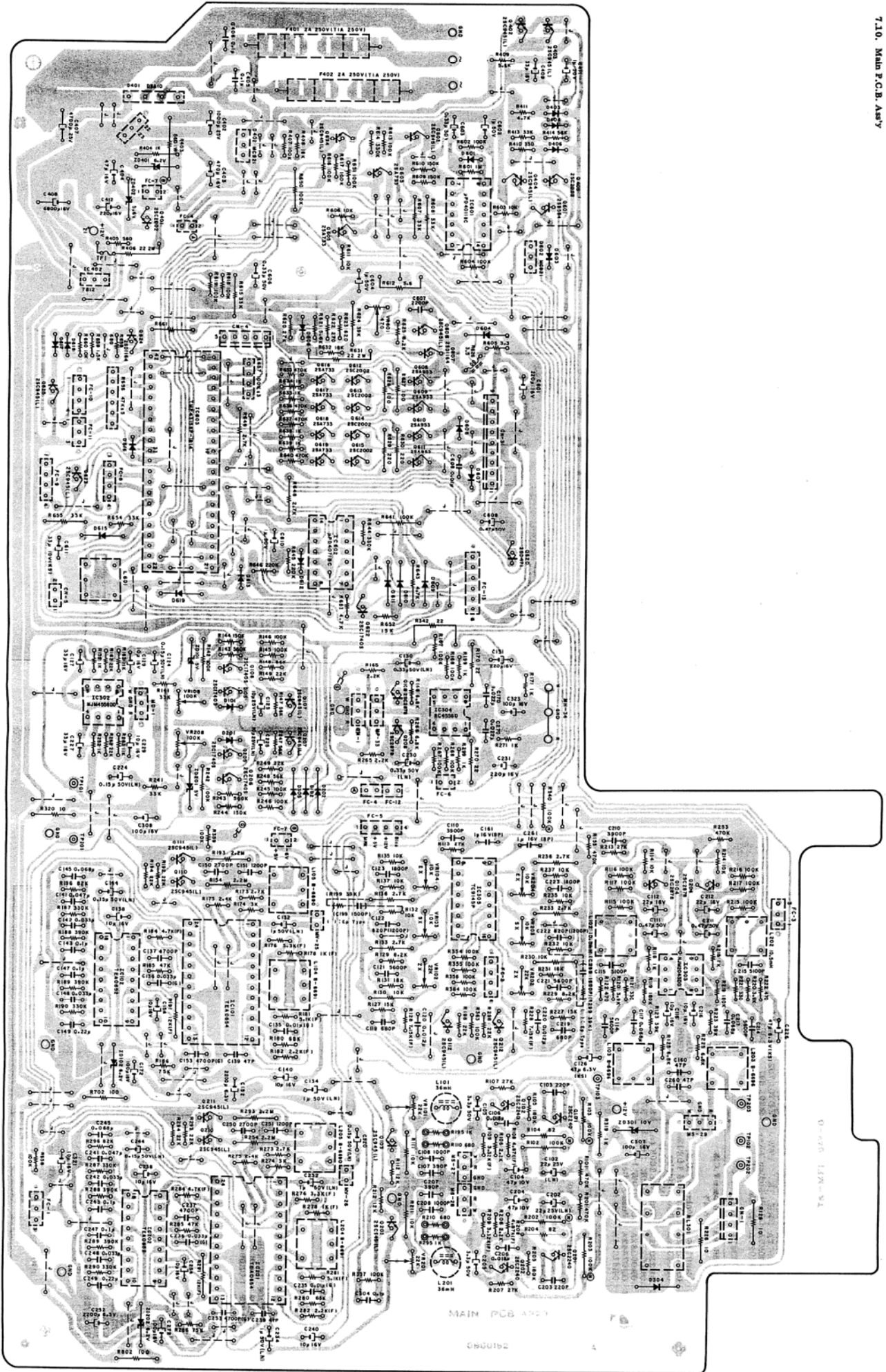

FIG. 7.10



8. SCHEMATIC DIAGRAM

8.1. IC Block Diagrams

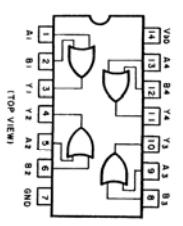

FIG. 8.1.1 OR Gate CMOS IC μPD4071BC (TOP VIEW)

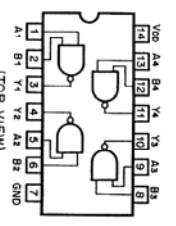

FIG. 8.1.2 NAND Gate CMOS IC μPD4011BC (TOP VIEW)

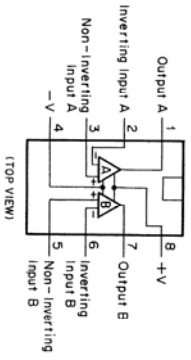

FIG. 8.1.3 Operational Amp. IC 4858D, NM4858DD, NM2048DD, TL082 (TOP VIEW)

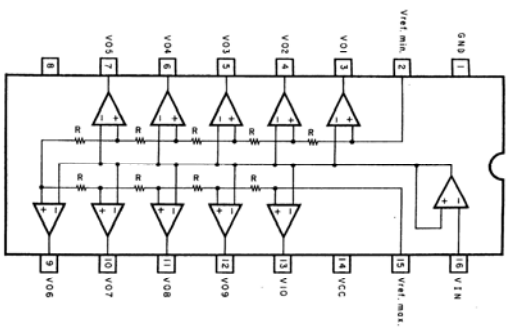

FIG. 8.1.4 Level Meter Driver TA7612AP

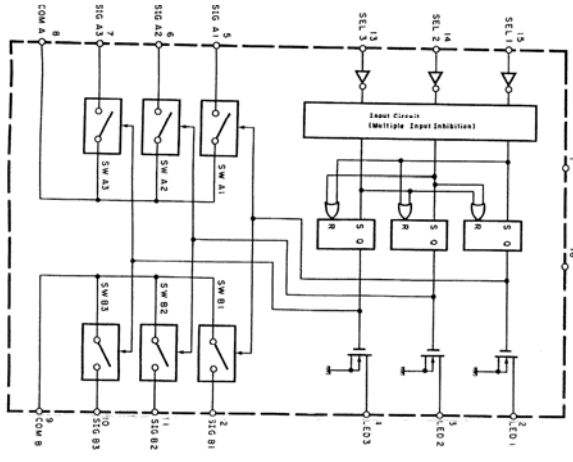

FIG. 8.1.5 Analog Switch Selector TC9145P

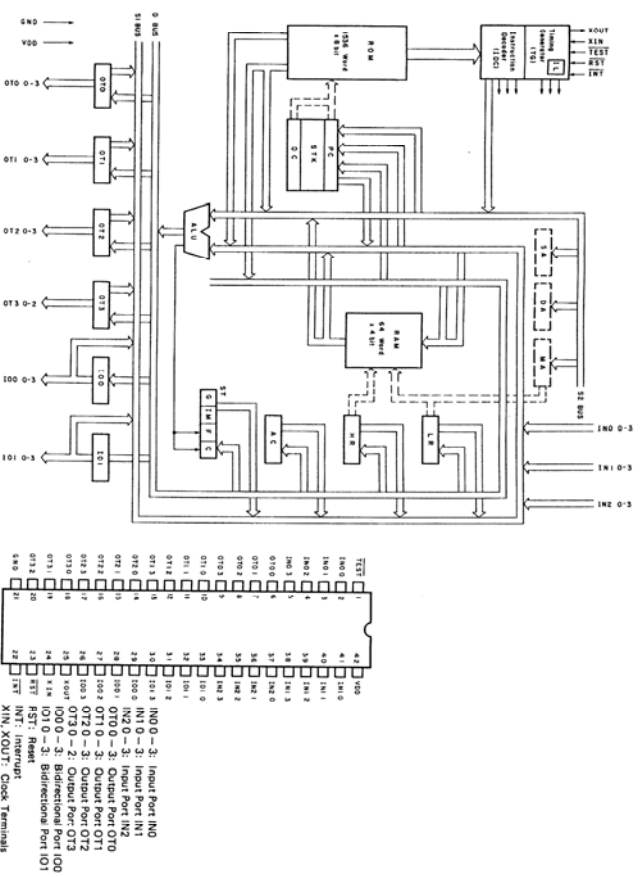
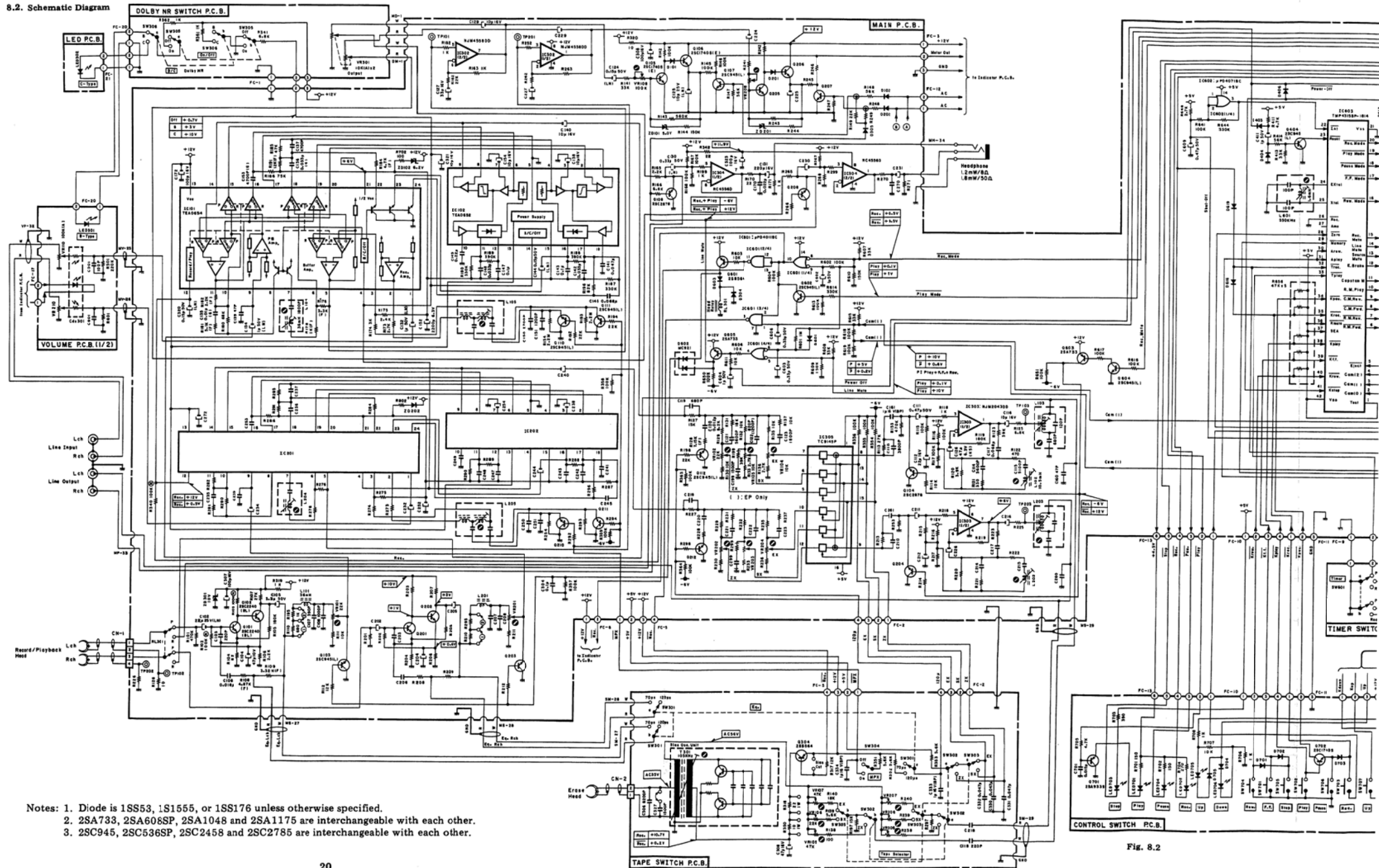

FIG. 8.1.6 4-Bit Micro-processor TMP4315BP-1814

8.2. Schematic Diagram



- Notes:
1. Diode is 1S853, 1S1555, or 1S8176 unless otherwise specified.
  2. 2SA733, 2SA608SP, 2SA1048 and 2SA1175 are interchangeable with each other.
  3. 2SC945, 2SC536SP, 2SC2458 and 2SC2785 are interchangeable with each other.

Fig. 8.2

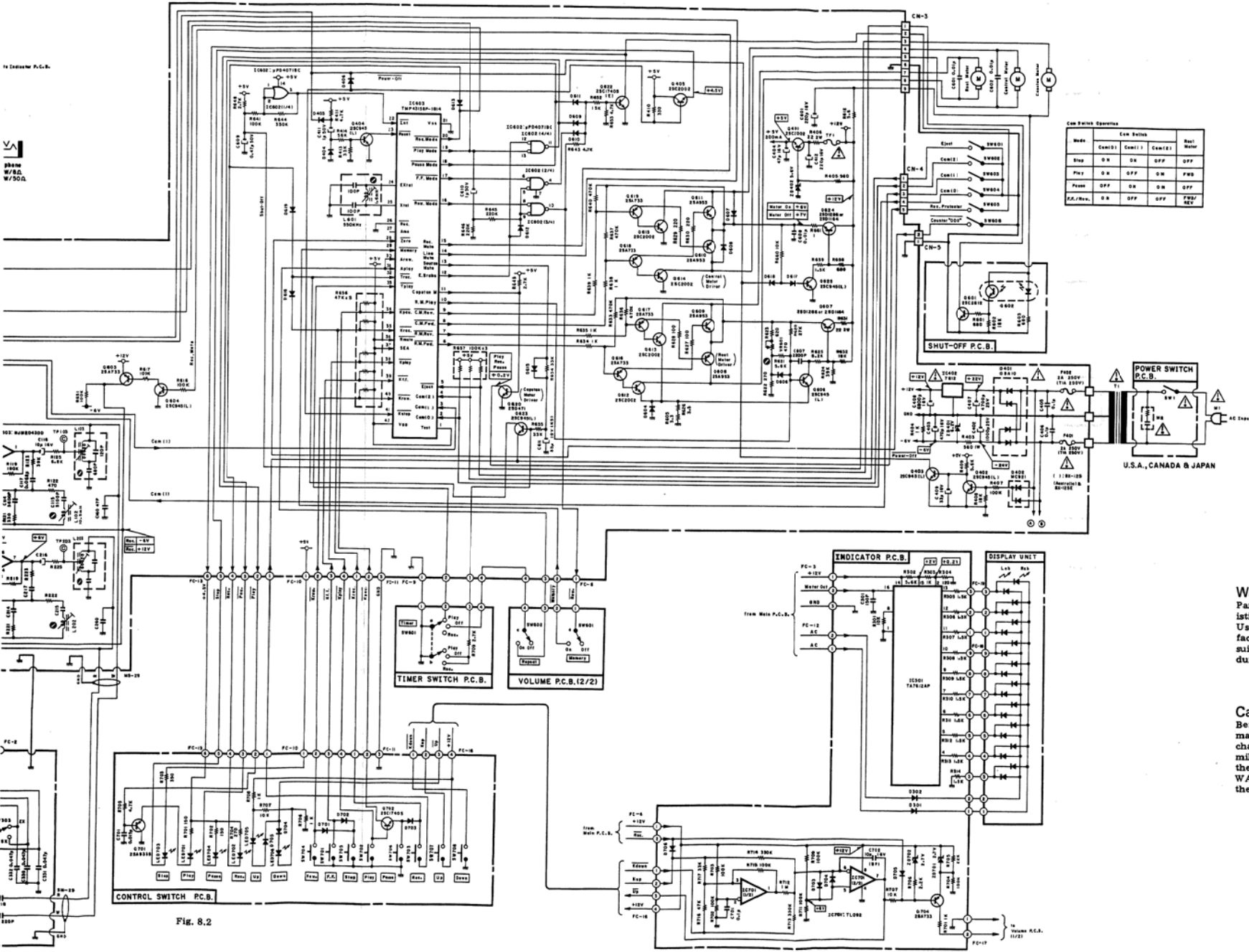
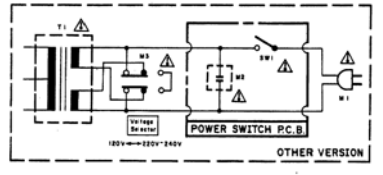
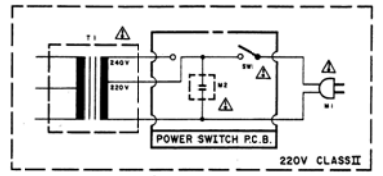
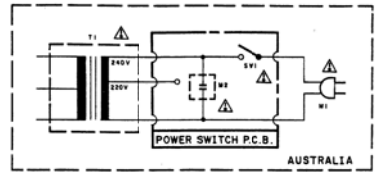
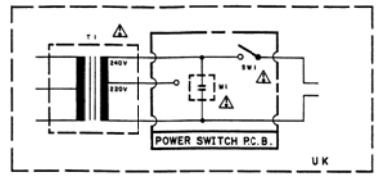

Fig. 8.2



**Warning:**  
Parts marked with the symbol have critical characteristics. Use ONLY replacement parts recommended by the manufacturer. It is recommended that the unit be operated from a suitable DC supply or batteries during initial check-out procedure.

**Caution:**  
Before returning the unit to the customer, make sure you make either (1) a leakage current check or (2) a line to chassis resistance check. If the leakage current exceeds 0.5 milliamper, or if the resistance from chassis to either side of the power cord is less than 240 k ohms, the unit is defective. **WARNING — DO NOT** return the unit to the customer until the problem is located and corrected.

9. WIRING DIAGRAM

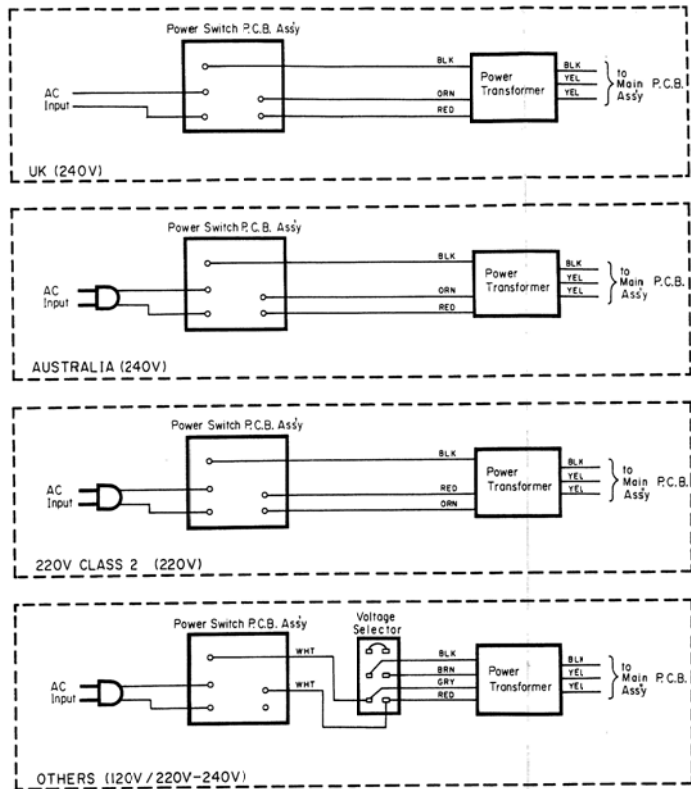

Notes: 1 Table of wire colors

BRN - Brown	BLU - Blue
RED - Red	VIO - Violet
ORN - Orange	GRY - Gray
YEL - Yellow	WHT - White
GRN - Green	BLK - Black

2. Component side view of the P.C.B. is illustrated unless otherwise specified.  
 3. Wire tube color is shown in ( ).

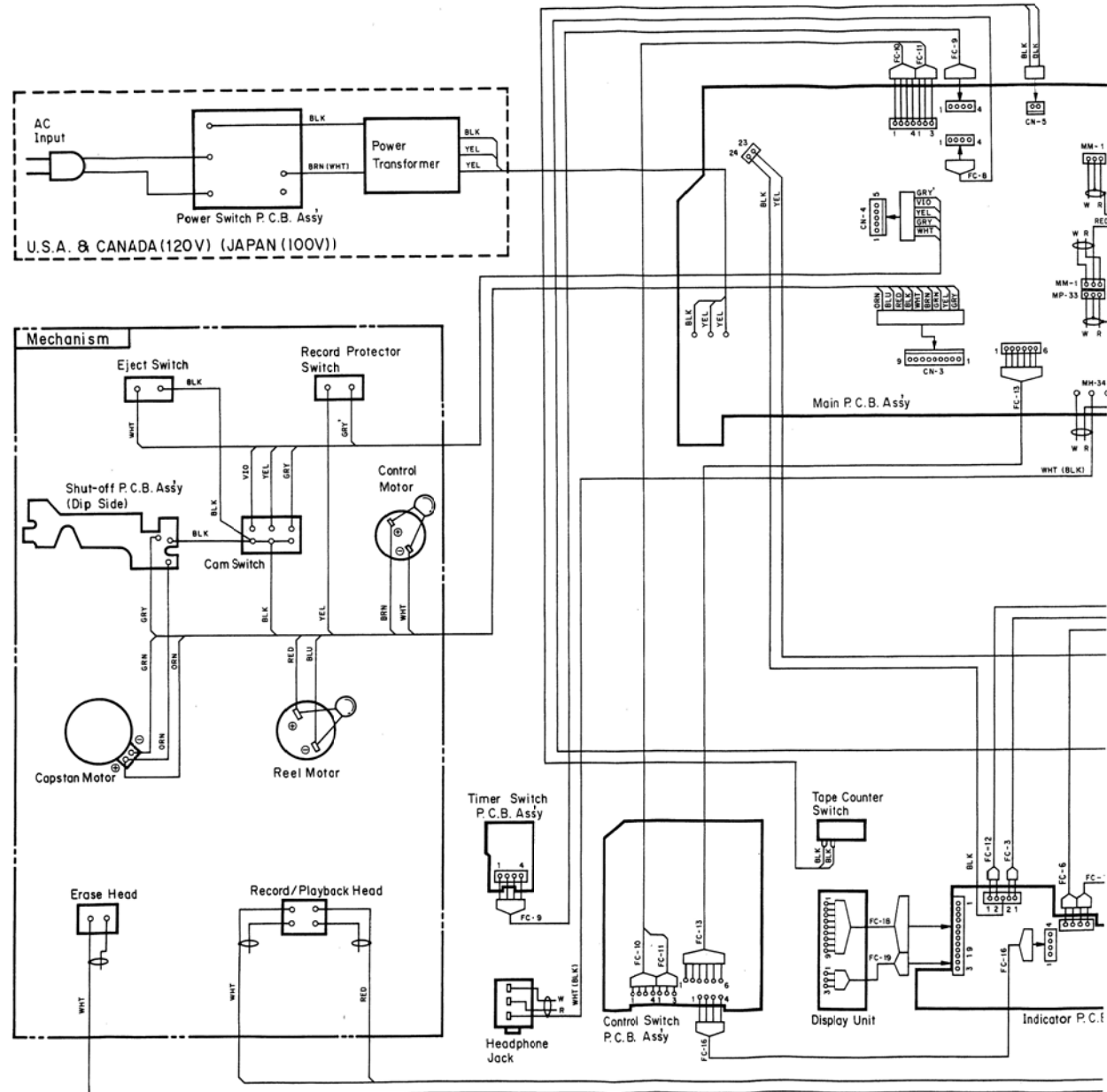

Fig. 9

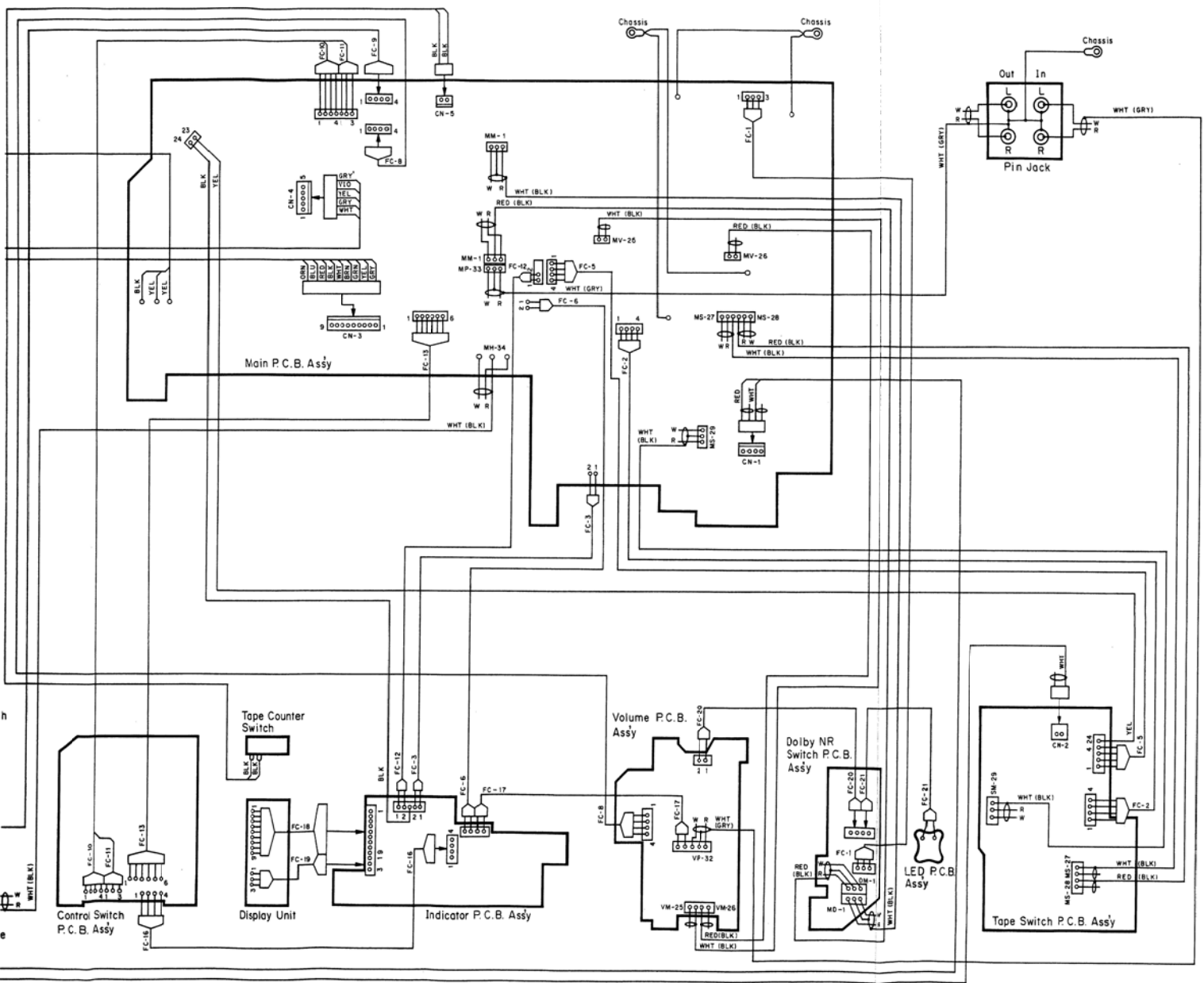

Fig. 9



# 10. BLOCK DIAGRAMS

## 10.1. Amplifier Section

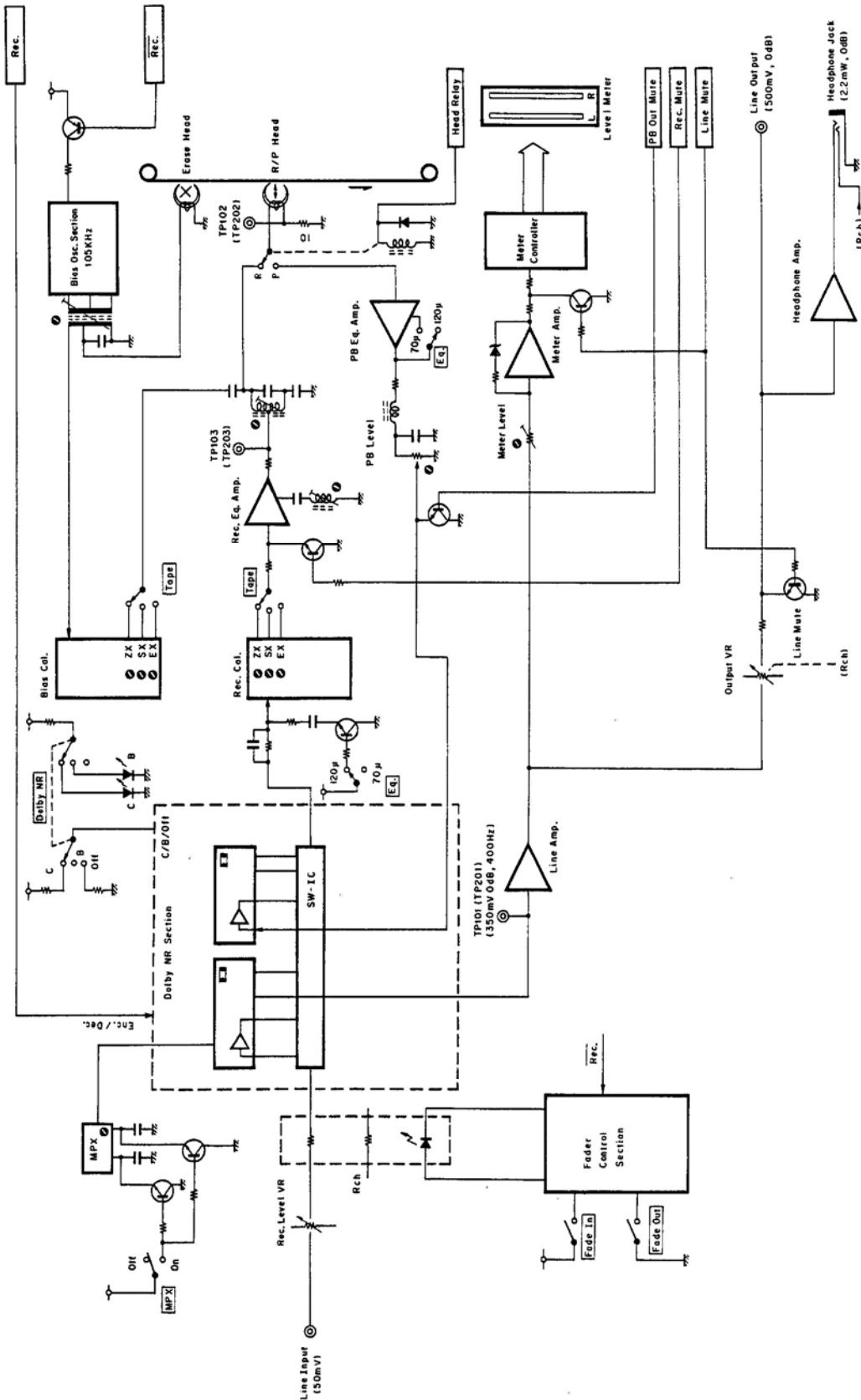

Fig. 10.1

10.2. Mechanism Control Section

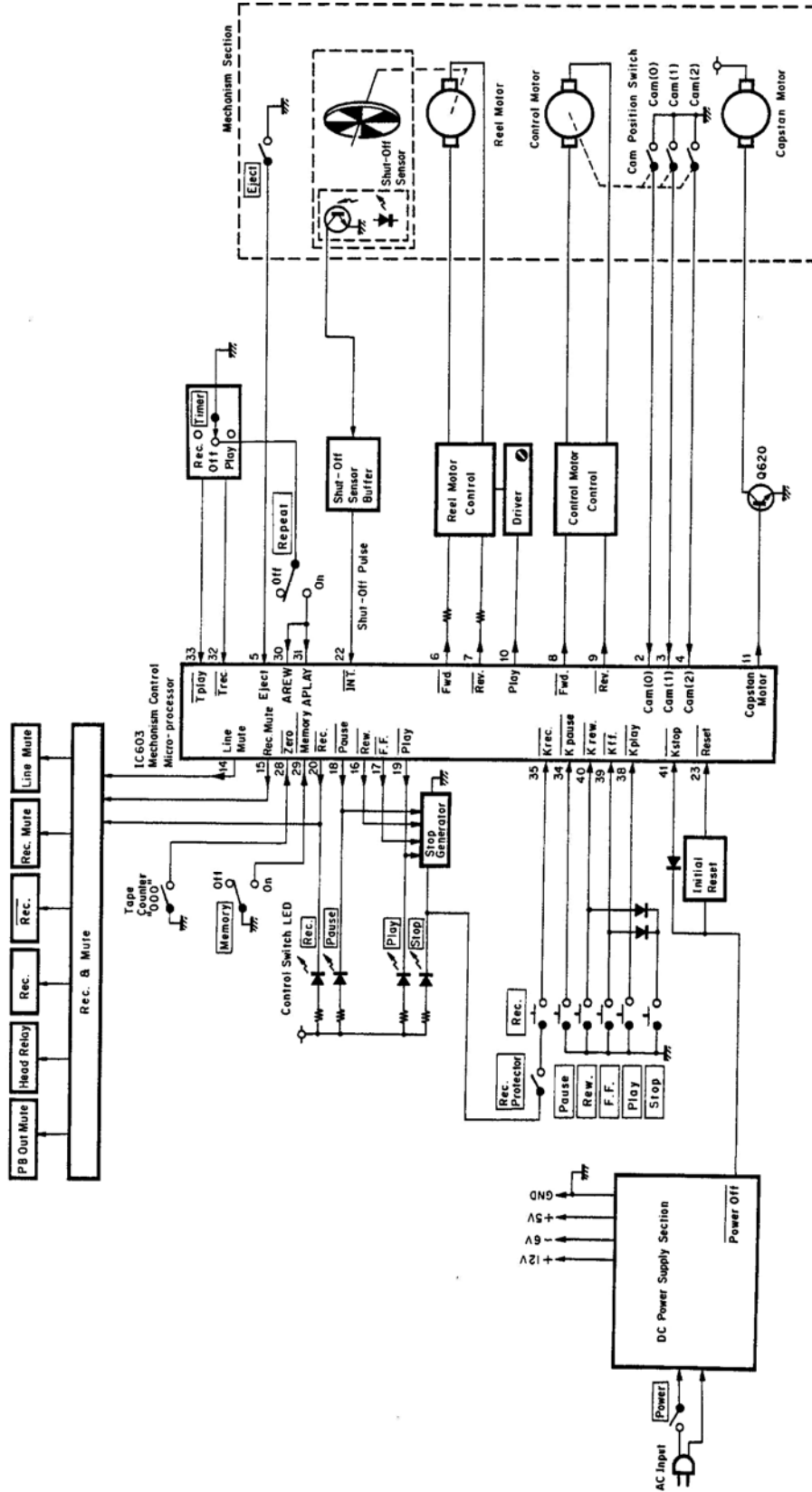

Fig. 10.2

# 11. TIMING CHART AND EQ. AMP. FREQUENCY RESPONSE

## 11.1. Timing Chart (1) Overall Timing Chart

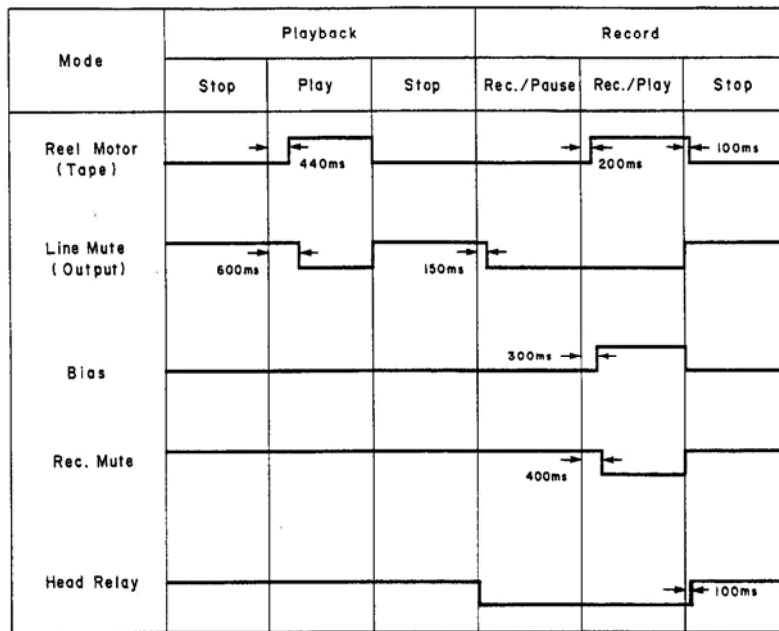

Fig. 11.1.1

## (2) Mechanism Control Timing Chart

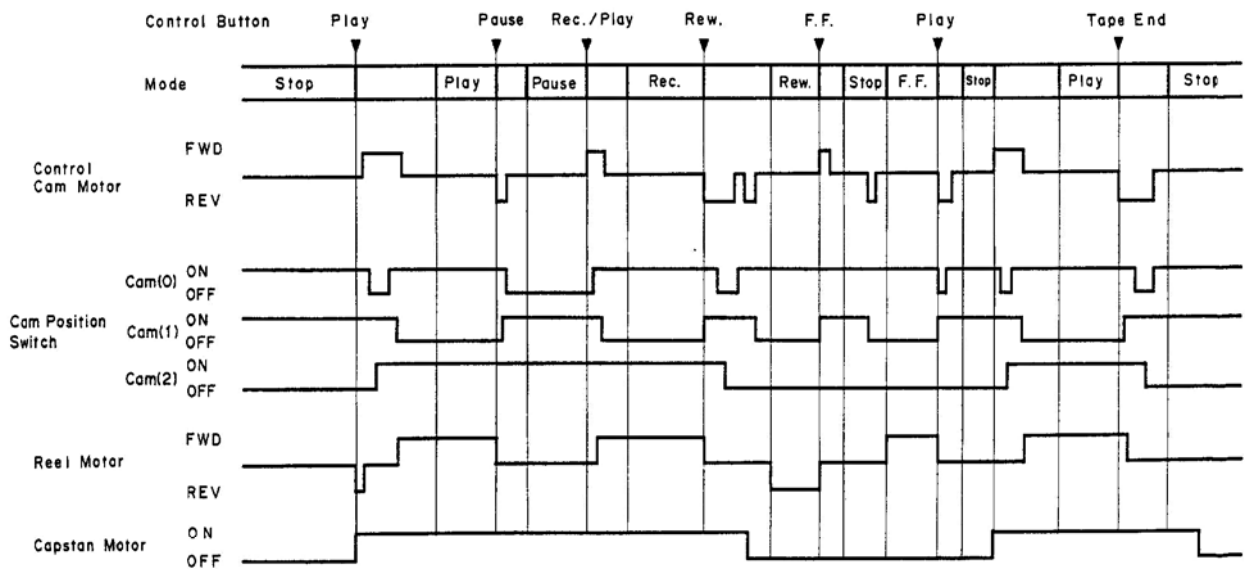

Fig. 11.1.2

**11.2. Eq. Amp. Frequency Response**  
**(1) Playback Frequency Response**

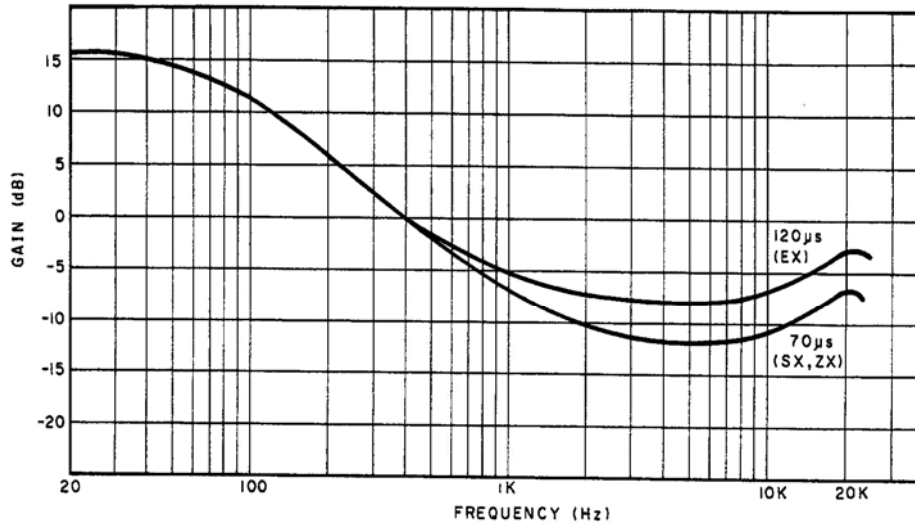

Fig. 11.2.1

**(2) Record Current Frequency Response**

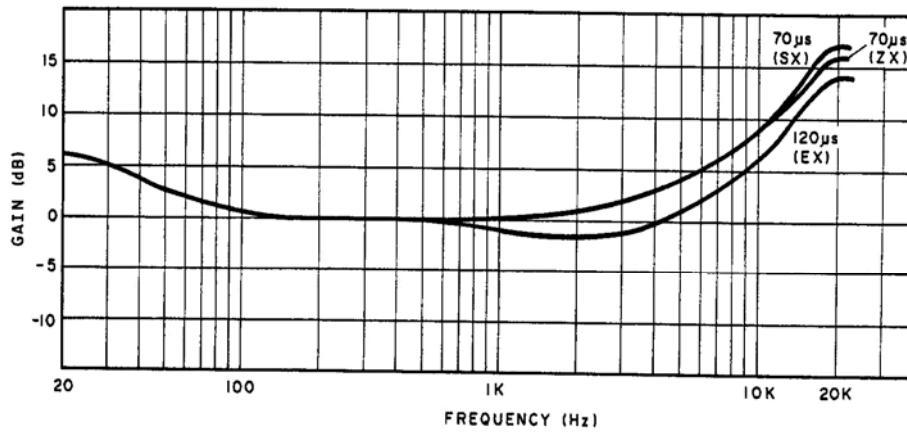

Fig. 11.2.2

## 12. SPECIFICATIONS

Track Configuration	4 Tracks/2-Channel Stereo
Heads	2 (Erase Head x 1, Record/Playback Head x 1)
Motors (Tape Transport)	DC Servo Motor (Capstan Drive) x 1 DC Motor (Reel Drive) x 1
Power Source	100, 120, 120/220-240, 220 or 240 V AC; 50/60 Hz (According to country of sale)
Power Consumption	23 W max.
Tape Speed	1-7/8 ips. (4.8 cm/sec.) $\pm 0.5\%$
Wow and Flutter	Less than $\pm 0.11\%$ WTD Peak Less than 0.06% WTD RMS
Frequency Response	20 Hz—20,000 Hz (recording level -20 dB)
Signal to Noise Ratio	Dolby C-Type NR on $<70 \mu\text{s}$ , ZX tape Better than 68 dB (400 Hz, 3% THD, IHF A-WTD RMS) Dolby B-Type NR on $<70 \mu\text{s}$ , ZX Tape Better than 62 dB (400 Hz, 3% THD, IHF A-WTD RMS)
Total Harmonic Distortion	Less than 1.0% (400 Hz, 0 dB, ZX, EXII tape) Less than 1.2% (400 Hz, 0 dB, SX tape)
Erasure	Better than 60 dB (100 Hz, 10 dB)
Separation	Better than 36 dB (1 kHz, 0 dB)
Crosstalk	Better than 60 dB (1 kHz, 0 dB)
Bias Frequency	105 kHz
Input (Line)	50 mV, 30 k $\Omega$
Output (Line)	0.5 V (400 Hz, 0 dB, output level control at max.) 2.2 k $\Omega$
(Headphones)	2.2 mW (400 Hz, 0 dB, output level control at max.) 8 $\Omega$ load
Fast-Winding Time	Approx. 85 seconds (with C-60 cassette)
Dimensions	430 (W) x 100 (H) x 250 (D) millimeters 16-15/16 (W) x 3-15/16 (H) x 9-7/8 (D) inches
Approximate Weight	5 kg 11 lb.

- Specifications and appearance design are subject to change for further improvement without notice.
- Noise Reduction System manufactured under license from Dolby Laboratories Licensing Corporation.
- The word "DOLBY" and the Double-D-Symbol are trademarks of Dolby Laboratories Licensing Corporation.

# Service Manual

# Nakamichi BX-125, BX-125E

## **Nakamichi Corporation**

Tokyo Office  
Shinjuku Daiichi Seimei Bldg.  
2-7-1 Nishishinjuku, Tokyo  
Phone (03) 342-4461  
Telex : 2324721 (NAKAM J)

## **Nakamichi U.S.A. Corporation**

19701 South Vermont Avenue  
Torrance, California 90502  
Phone : (213) 538-8150

## **Nakamichi GmbH**

Stephanienstrasse 6, 4000 Düsseldorf 1  
Phone : (0211) 359036