

Nakamichi

Service Manual

Nakamichi CD Player 4

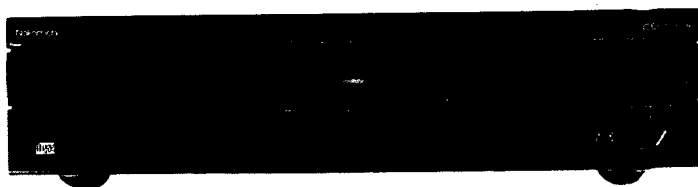

MC-Service

CONTENTS

1. General	1
2. Removal Procedures	4
2. 1. Top Cover Ass'y	4
2. 2. Disc Tray Cover Ass'y	4
2. 3. Front Panel Ass'y	4
2. 4. Disc Mechanism Ass'y	4
2. 5. Laser Pickup	5
2. 6. Disc Tray and Loading Belt	6
3. Measurement Instruments and Jigs	6
4. Parts Location for Electrical Adjustment	8
5. Adjustments	9
6. Mechanism Ass'y and Parts List	12
6. 1. Synthesis	12
6. 2. Front Panel Ass'y (A01)	13
6. 3. Chassis Ass'y (A02)	14
6. 4. Disc Mechanism Ass'y (A03)	15
6. 5. Disc Mechanism Sub Ass'y (B01)	16
7. Mounting Diagrams and Parts List	17
7. 1. Power Switch P.C.B. Ass'y	17
7. 2. Headphone Amp. P.C.B. Ass'y	17
7. 3. Sub P.C.B. Ass'y	17
7. 4. Control & Display P.C.B. Ass'y	18
7. 5. Main P.C.B. Ass'y	20
8. Schematic Diagram	22
8. 1. IC Block Diagrams	22
8. 2. Schematic Diagram	30
9. Wiring Diagram	31
10. Block Diagram	32
11. Timing Chart	33
12. Specifications	34

1. GENERAL

1.1. Model No.
Model No.: V313

1.2. Destinations
USA, CAN, EP, AUS, OTR, JPN

Abbreviation	
USA — U.S.A.	AUS — Australia
CAN — Canada	OTR — Other
EP — Europe	JPN — Japan

1.3. CAUTIONS/WARNINGS

(1) Product Safety Notice
Parts marked with the symbol  in the schematic diagram have critical characteristics.
Use ONLY replacement parts recommended by the manufacturer.
It is recommended that the unit be operated from a suitable DC supply or batteries during initial check-out procedures.

(2) Leakage Current Check/Resistance Check
Before returning the unit to the customer, make sure you make either (1) a leakage current check or (2) a line to chassis resistance check. If the leakage current exceeds 0.5 milliamp, or if the resistance from chassis to either side of the power cord is less than 240 k ohms, the unit is defective.

WARNING — DO NOT return the unit to the customer until the problem is located and corrected.

(3) Protection of Eyes from Laser Beam
To protect eyes from invisible laser beam during servicing, DO NOT LOOK AT THE LASER BEAM.

- Laser Diode Properties
Laser Output: 44.6 μ W Max.
Measured at a distance of about 200 mm from the object lens surface on the Laser Pickup.
Wavelength: 780 nm
Emission Duration: Continuous

● Laser Caution Label and Class 1 Laser Product Label (for EP)

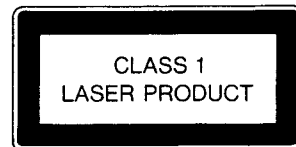
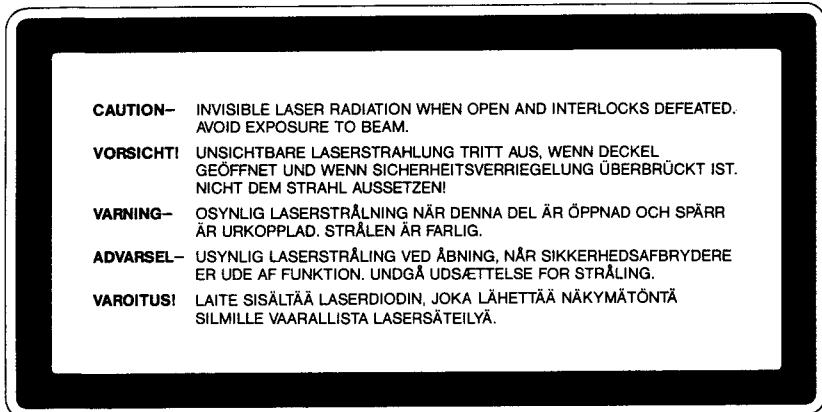

THIS COMPACT DISC PLAYER IS CLASSIFIED AS A CLASS 1 LASER PRODUCT. THE CLASS 1 LASER PRODUCT LABEL IS LOCATED ON THE REAR EXTERIOR.

1.4. Handling the Laser Pickup

In case of repair or replacement of the Laser Pickup, pay attention to the following handling instructions since the laser diode in the Laser Pickup is not resistant to static electricity.

(1) Grounding

When you repair a Laser Pickup, first ground the human body, as well as the measuring instruments and other tools (with particular caution to soldering iron). What's more, your workbench and floor should desirably be grounded using conductive sheet or copper plate. See Fig. 1.1.

Note: Be careful so as not to let your clothes touch the Laser Pickup, as static electricity on the clothes will not be released even if your body is grounded.

(2) Discharge of Electricity

Be sure to discharge electricity from objects brought into contact with the Laser Pickup (i.e., soldering iron, tweezers, probes, volt-ohm-meter probes, etc.) before starting work by contacting them with the Compact Disc Player's chassis. Besides, never touch the Laser Pickup while power is applied.

(3) Soldering Iron to be Used

The soldering iron for use in repair work should be: (1) a ceramic soldering iron, (2) a soldering iron with its metal part grounded, or (3) a soldering iron whose insulation resistance after five minutes of power application is 10 M-ohm or more at 500 VDC. Soldering should be completed promptly, at a soldering iron temperature of 320° max (39 W). A soldering iron heated above this temperature can break down the laser diode.

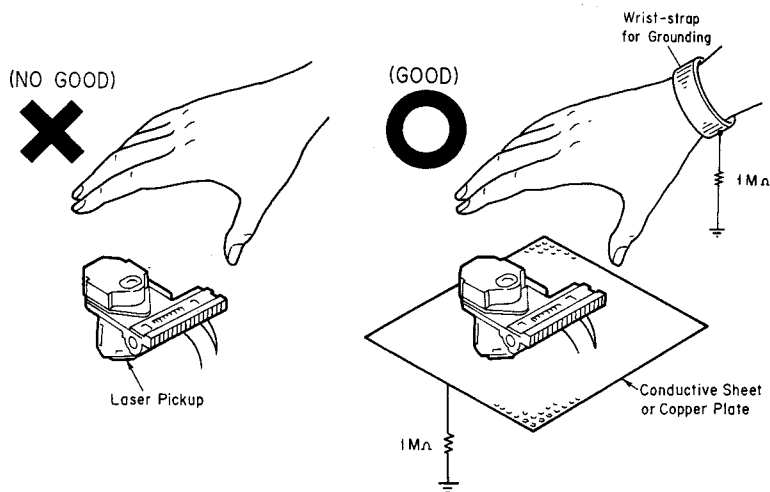

Fig. 1.1

1.5. Voltage Selector

Voltage Selector is installed on the Rear Panel of the Nakamichi CD Player 4 (Other). The voltage selector can select either 110V/127V or 220V/240V at customer's disposal.

1.6. Parts Supply

(1) Unstocked Parts

Parts marked with "★" at the head of part No. are not stocked. So, it takes time to supply the parts after we receive your order.

(2) Unsupplied Parts

Parts without part Nos. (indicated as "—" in the parts list) are not supplied.

1.7. Package Ass'y and Accessory Ass'y

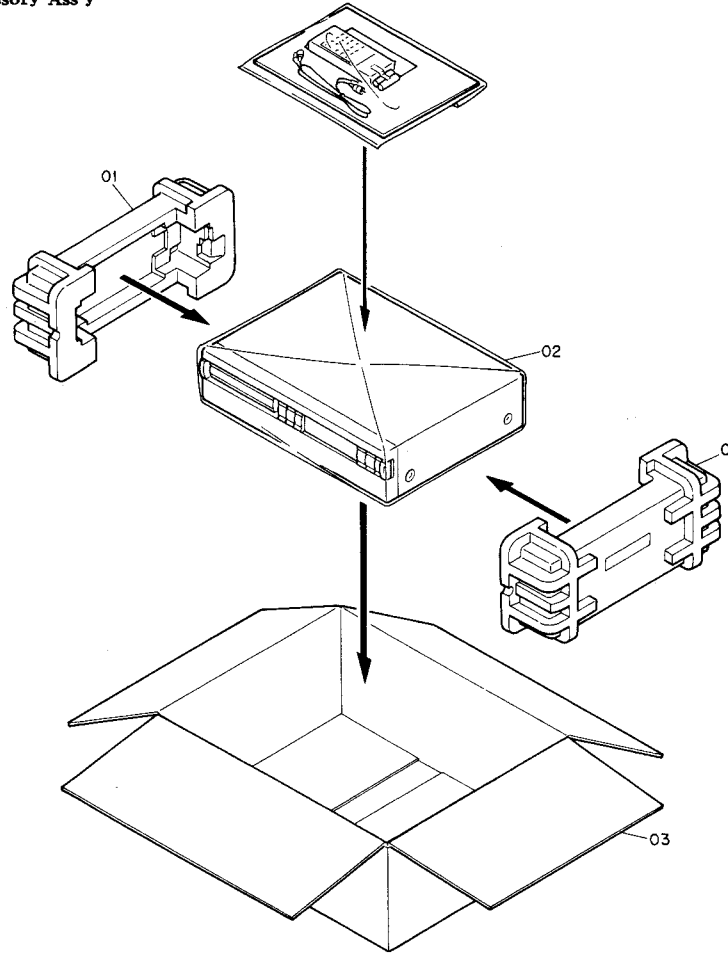

Fig. 1.2

Schematic Ref. No.	Part No.	Description	Q'ty	Schematic Ref. No.	Part No.	Description	Q'ty
	—	Package Ass'y			DA04340A	Accessory Ass'y (USA, CAN)	1
01	OF04434A	Packing	2		DA04338A	Accessory Ass'y (EP)	1
02	OF04458A	Poly Sheet	1		DA04337A	Accessory Ass'y (AUS)	1
03	OF04433A	Carton Box	1		DA04334A	Accessory Ass'y (OTR)	1
					DA04333A	Accessory Ass'y (JPN)	1
					OB90451A	Battery UM3	2
					OD03092B	Poly Bag for Accessory 320x340x0.08	1
					OD06097A	Owner's Manual(English/German/ French)	1
					OD06098A	Owner's Manual(Japanese)	1
					DA04331A	Remote Control Unit (CD Player 4)	1
					DA04388A	Pin-Pin Cord Ass'y	1

2. REMOVAL PROCEDURES

2.1. Top Cover Ass'y

Refer to Fig. 2.1.

- (1) Loosen screws F01 (2 pcs.) and F02 (4 pcs.), and remove F03 (Top Cover Ass'y) upward.

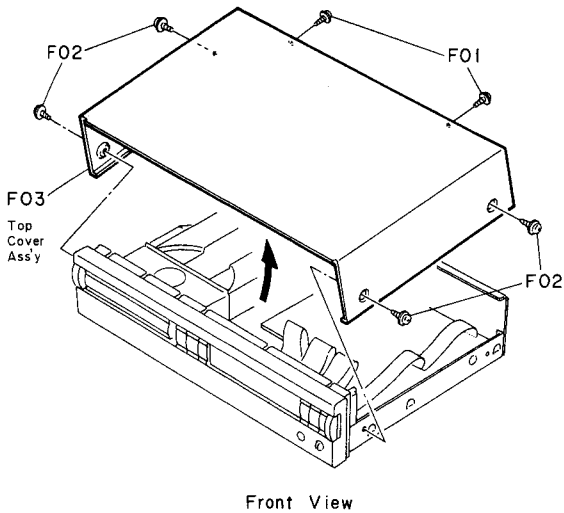

Fig. 2.1

2.2. Disc Tray Cover Ass'y

Refer to Fig. 2.2.

- (1) Turn ON the Power switch.
- (2) Press the Eject/Load button to eject the Disc Tray.
- (3) Turn OFF the Power switch.
- (4) Pull F01 (Disc Tray Cover Ass'y) upward to remove it.

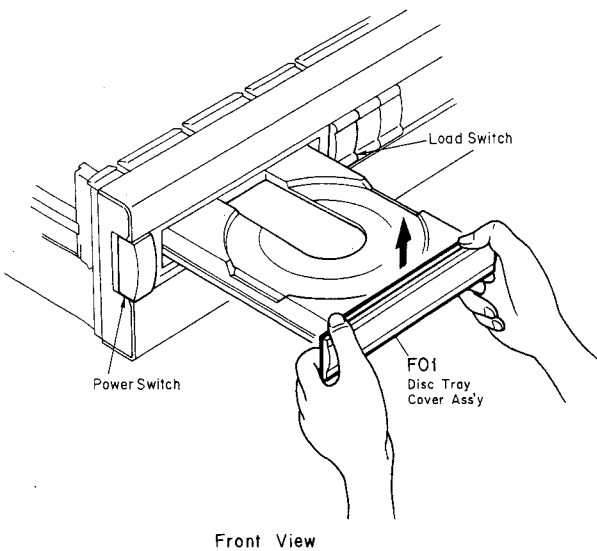

Fig. 2.2

2.3. Front Panel Ass'y

Refer to Fig. 2.3.

- (1) Remove the Top Cover Ass'y referring to item 2.1.
- (2) Remove the Disc Tray Cover Ass'y referring to item 2.2.
- (3) Loosen screws F01 (2 pcs.) and F02 (3 pcs.), and remove F03 (Front Panel Ass'y).

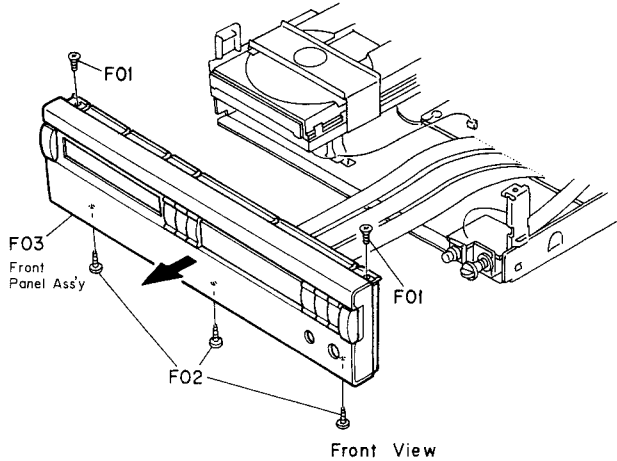

Fig. 2.3

2.4. Disc Mechanism Ass'y

Refer to Figs. 2.4.1 and 2.4.2.

- (1) Remove the Top Cover Ass'y referring to item 2.1.
- (2) Remove the Disc Tray Cover Ass'y referring to item 2.2.
- (3) Short the lands "A" on the Sub P.C.B. Ass'y which is mounted at the back of the Disc Mechanism Ass'y. See Fig. 2.4.1.

- Cautions:**
1. Use a soldering iron whose metal part is grounded, or a ceramic soldering iron.
 2. Do not forget shorting. Otherwise, the Laser Pickup will be damaged when connectors of the Disc Mechanism Ass'y are disconnected from the Main P.C.B. Ass'y.

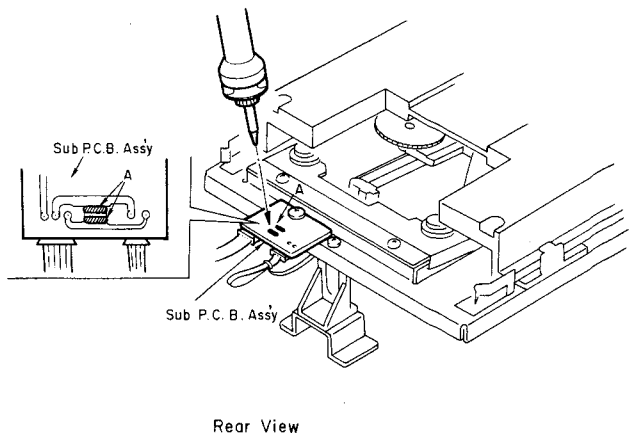

Fig. 2.4.1

- (4) Loosen screws F01 (3 pcs.), disconnect connectors from the Main P.C.B. Ass'y, and remove F02 (Disc Mechanism Ass'y). See Fig. 2.4.2.

Note: On installing F02 (Disc Mechanism Ass'y), do not remove soldering of the lands "A" on the Sub P.C.B. Ass'y before connecting all connectors to the Main P.C.B. Ass'y.

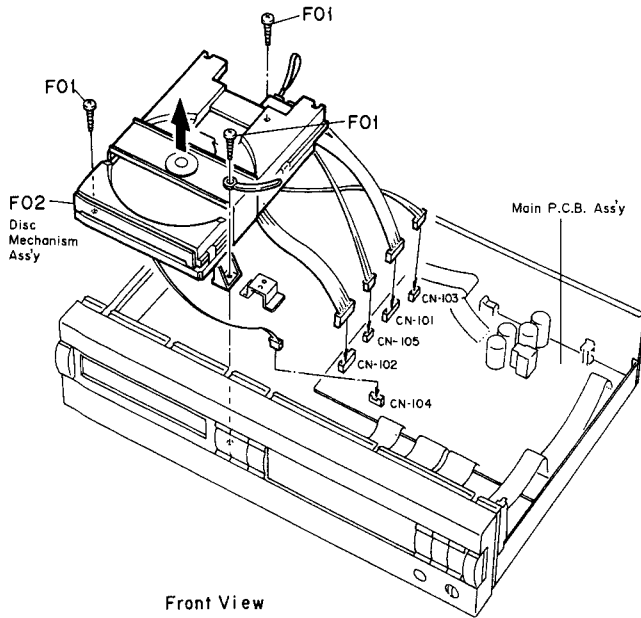

Fig. 2.4.2

2.5. Laser Pickup

Refer to Figs. 2.5.1 and 2.5.2.

2.5.1. Removing the Laser Pickup

- (1) Remove the Disc Mechanism Ass'y referring to item 2.4. (Do not forget shorting the lands "A" on the Sub P.C.B. Ass'y.)
- (2) Turn over the Disc Mechanism Ass'y and short the lands "B" on the P.C.B. of the Laser Pickup. See Fig. 2.5.1.

Cautions: 1. Use a soldering iron whose metal part is grounded, or a ceramic soldering iron.
2. Do not forget shorting the land "B" as the Laser Pickup will be damaged when it is removed.

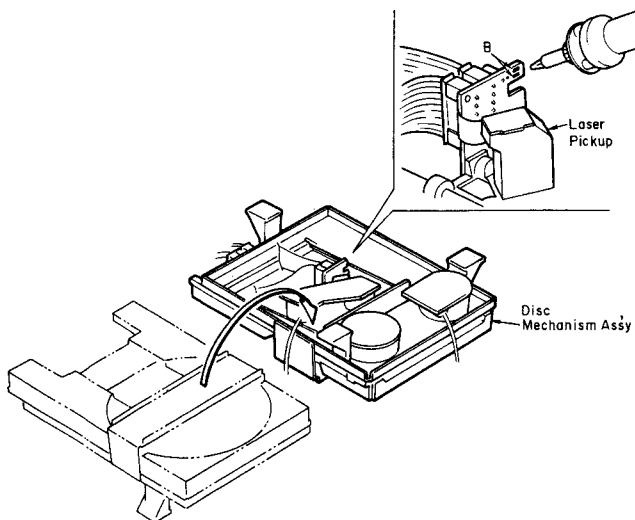

Fig. 2.5.1

- (3) Slide the Disc Tray forward by hand.
- (4) Loosen screws F01 (2 pcs.) and remove F02 (Chuck Chassis Ass'y). See Fig. 2.5.2.
- (5) Loosen a screw F03 and remove F04 (Gear A).
- (6) Loosen screws F05 (2 pcs.) and remove F06 (Shaft Clamp, 2 pcs.).
- (7) Pull out F07 (Slide Shaft) from F08 (Laser Pickup).

2.5.2. Installing a New Laser Pickup

Note: As a Laser pickup is packed in a conductive pack, do not take it out of the pack until you need it.

- (1) Install a new Laser Pickup by reversing procedures in item 2.5.1. See Fig. 2.5.2.
- (2) Turn over the Disc Mechanism Ass'y and remove soldering of the lands B on the P.C.B. of the Laser Pickup. See Fig. 2.5.1.
- (3) Install the Disc Mechanism Ass'y with three screws and connect all connectors to the Main P.C.B. Ass'y. See Fig. 2.4.2.
- (4) Remove soldering of the lands A on the Sub P.C.B. Ass'y at the back of the Disc Mechanism Ass'y. See Fig. 2.4.1.

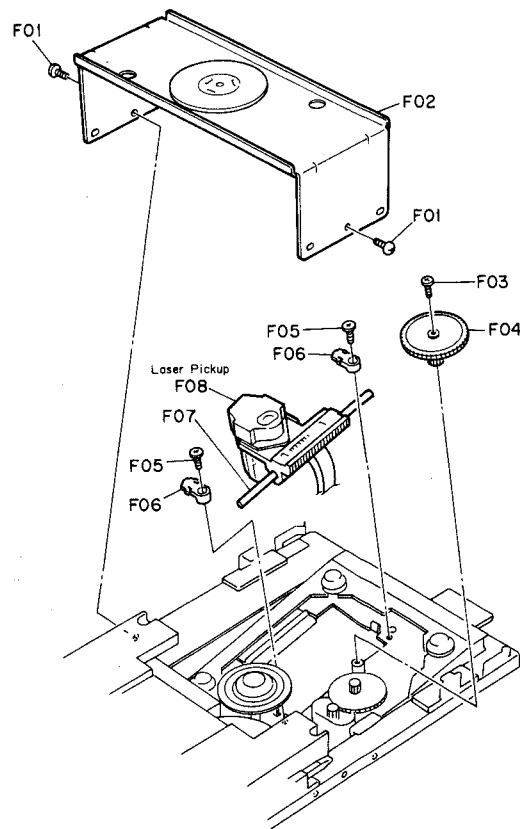

Fig. 2.5.2

2.6. Disc Tray and Loading Belt

Refer to Fig. 2.6.

- (1) Remove the Top Cover Ass'y referring to item 2.1.
- (2) Remove the Disc Tray Cover Ass'y referring to item 2.2.
- (3) To set F02 (Disc Tray) free, push it until it reaches the end.
- (4) Loosen screws F01 (2 pcs.) and pull out F02 (Disc Tray) forward.

- (5) Loosen a screw F03, remove F04 (Gear Cover), and disengage F05 (Loading Belt).

Note: When installing F02 (Disc Tray), turn F06 (Drive Gear) so that it is positioned as shown in Fig. 2.6 before inserting F02 (Disc Tray).

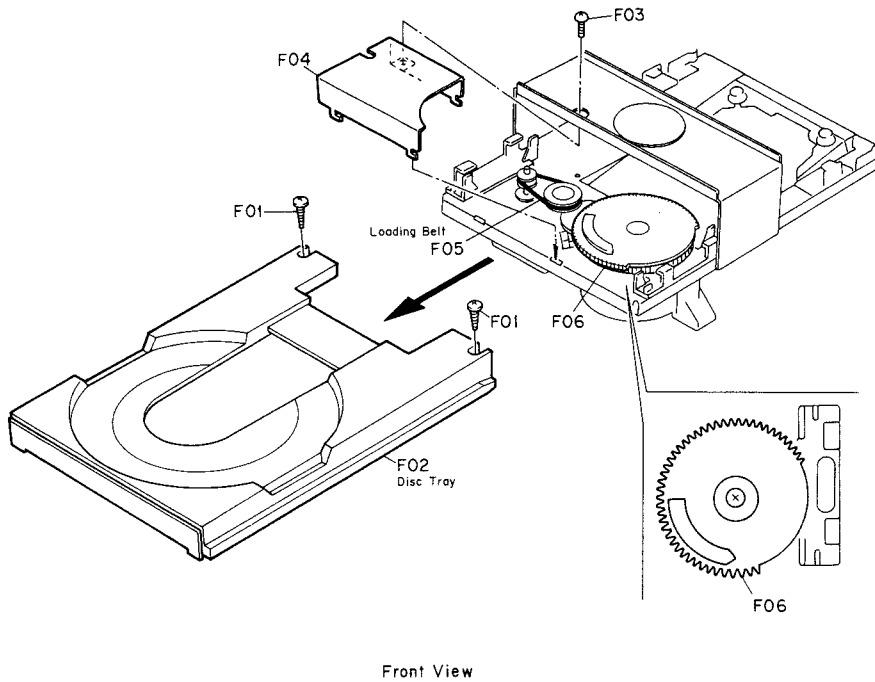

Front View

Fig. 2.6

3. MEASUREMENT INSTRUMENTS AND JIGS

- (1) Oscilloscope (15 MHz or more)
- (2) DC Voltmeter
- (3) Oscillator
- (4) Frequency Counter
- (5) Distortion Meter
- (6) Philips Test Disc 5/5A
- (7) SONY Test Disc YEDS-7 (Type 3)
- (8) ● CD Player Test Unit (DA09155A)
● Test Unit Cable for CD Player 4 (DA09156A)

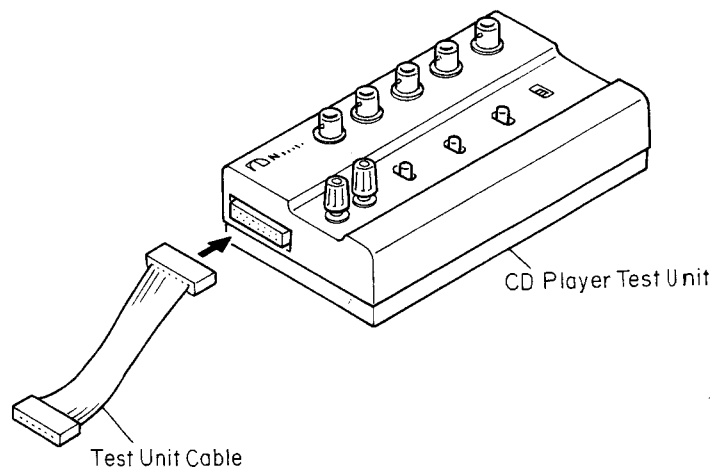

Fig. 3.1 Test Unit

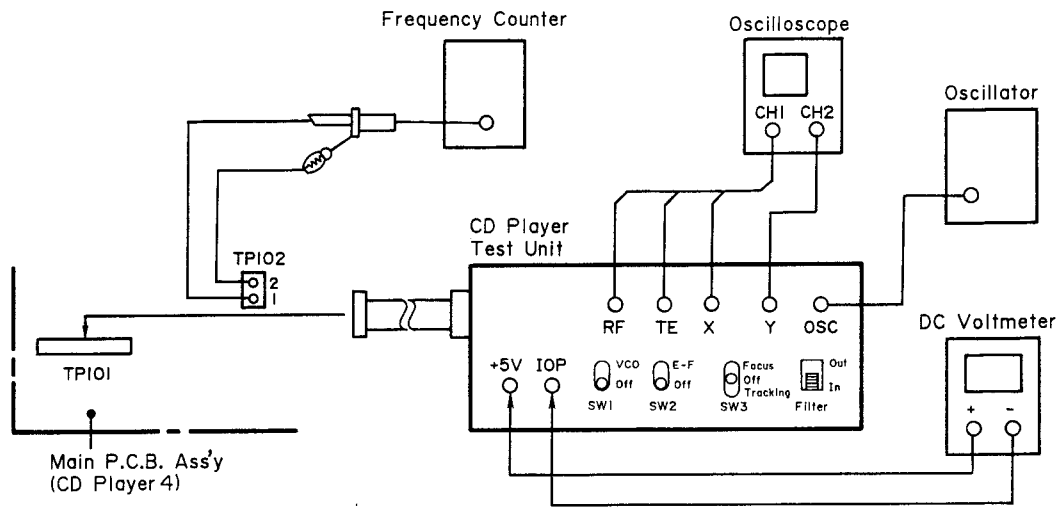

Fig. 3.2 Test Unit Connecting Diagram

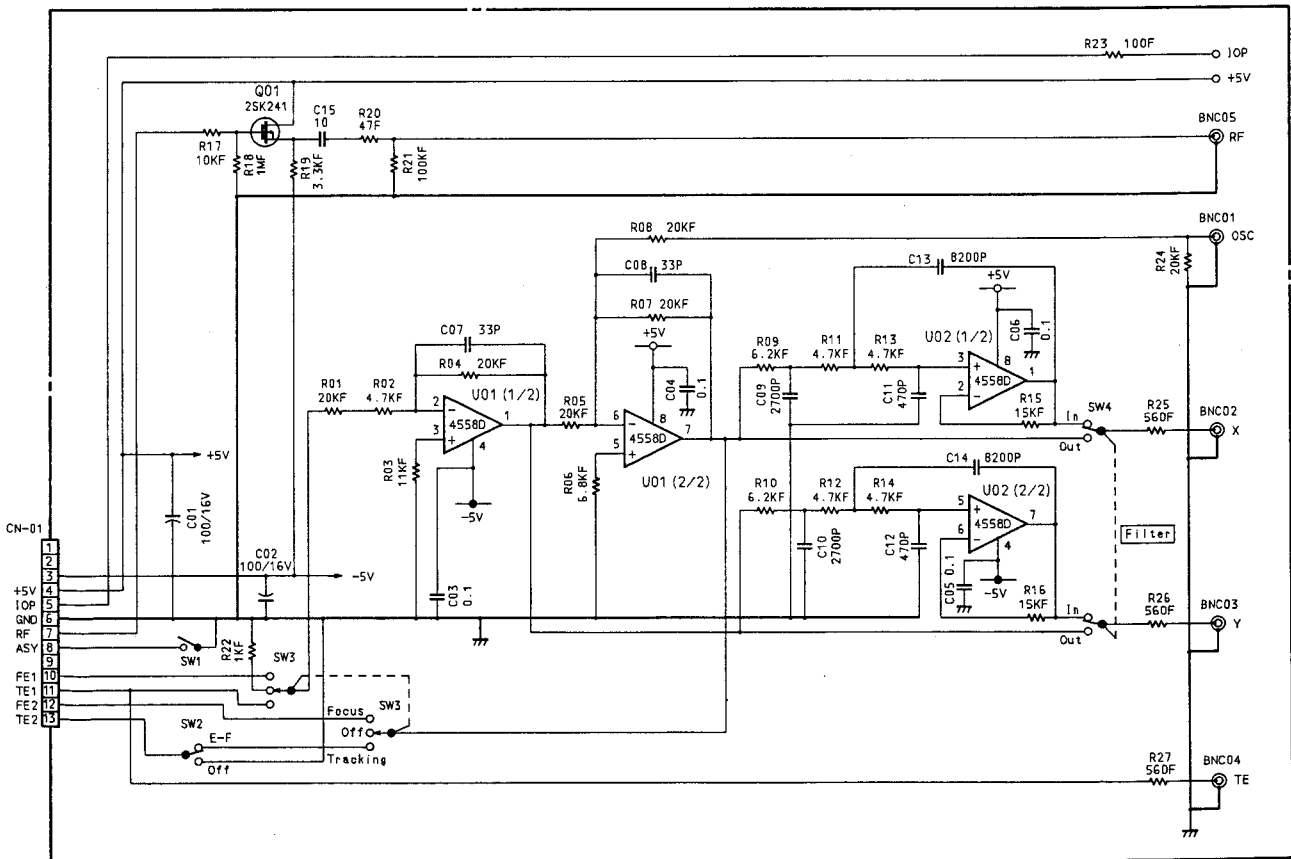

Fig. 3.3 Test Unit Circuit Diagram

4. PARTS LOCATION FOR ELECTRICAL ADJUSTMENT

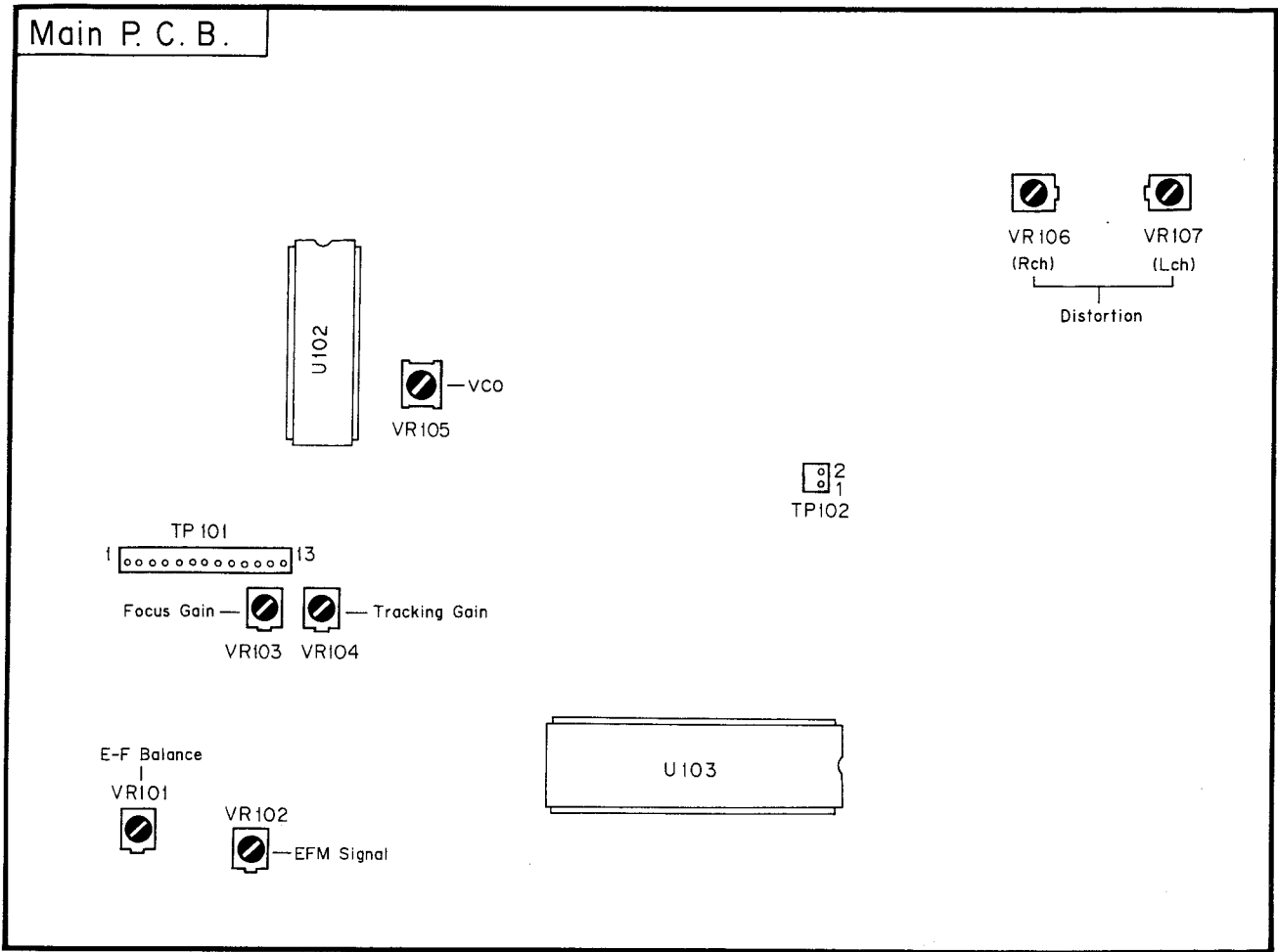
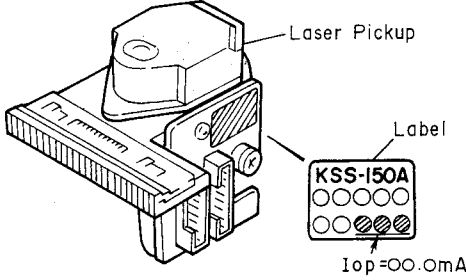
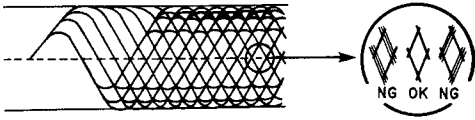
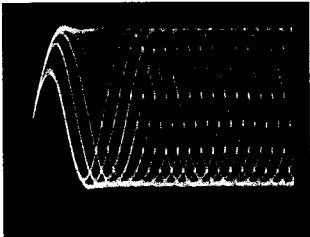
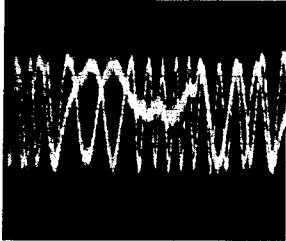
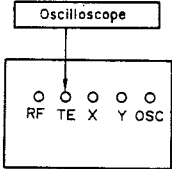
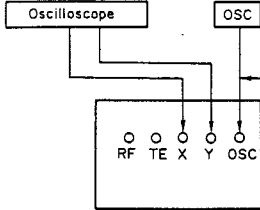
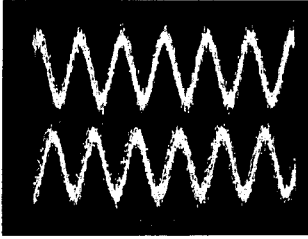
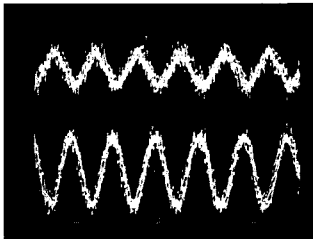
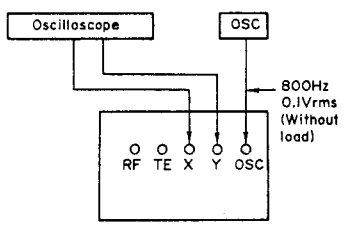
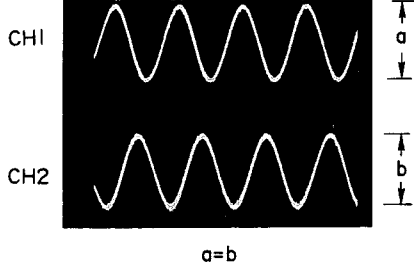
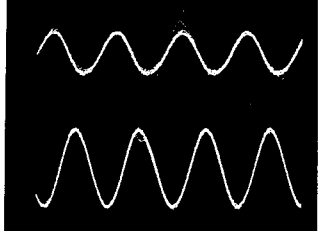

Fig. 4

5. ADJUSTMENTS

STEP	ITEM	SIGNAL SOURCE	OUTPUT CONNECTION	ADJUSTMENT	REMARKS
1	Preliminary Step				<p>Connect the Test Unit to TP101 on the Main P.C.B. Ass'y via the Test Unit Cable. (See Fig. 3.2.)</p> <p>Note: In the following cases, preset the following semi-fixed volumes to their mechanical center positions before starting adjustment.</p> <ul style="list-style-type: none"> VR101, VR102, VR103, VR104 o When Main P.C.B. Ass'y is replaced with new one. o When VR101, VR102, VR103, or VR104 is replaced with new one.
2	Laser Current Check	Philips Test Sample 5	DC Voltmeter between Iop and +5V Terminals of Test Unit		<ol style="list-style-type: none"> 1. Turn the power ON and load the test disc. 2. Play back the test disc and calculate the current flowing into R102 from the following formula. $I = \frac{\text{Voltmeter Value}}{R102 (22 \text{ Ohms})} = \text{oo.o mA (Measured Value)}$ <p>Note: The voltmeter value should be read to 3 digits after the decimal point.</p> <ol style="list-style-type: none"> 3. Press the Eject/Load button to open the Disc Tray and check that the difference between the measured value and the current value (Iop) indicated on the label on the Laser Pickup is within ±10%. $Iop - (\text{Measured Value}) = Iop \pm 10\%$ <div style="text-align: center;">  <p>Laser Pickup</p> <p>Label</p> <p>KSS-150A</p> <p>Iop=00.0mA</p> </div>
3	VCO Frequency Adjustment	None	Frequency Counter (10/1 probe) between Pins 1 (PLCK) and 2 (GND) of TP102 on Main P.C.B.	VR105	<ol style="list-style-type: none"> 1. Set SW1 of the Test Unit to VCO. 2. Adjust VR105 to obtain 4.318 ±0.005 MHz on the frequency counter. 3. Set SW1 to OFF position.
4	EFM Signal Adjustment	Philips Test Sample 5	Oscilloscope to RF Connector of Test Unit	VR102	<ol style="list-style-type: none"> 1. Play back the first track of the test disc. 2. Adjust VR102 until waveform amplitude becomes maximum and the waveform becomes clear (not thick) as shown below: <div style="text-align: center;">  </div> <div style="text-align: center;">  </div> <p>Oscilloscope Setting: AC Mode, 0.2 V/div, 0.5 μs/div</p>

STEP	ITEM	SIGNAL SOURCE	OUTPUT CONNECTION	ADJUSTMENT	REMARKS
5	E-F Balance Adjustment (Supplementary Beam Balance Adjustment)	Philips Test Sample 5	Oscilloscope to TE Connector of Test Unit	VR101	<ol style="list-style-type: none"> 1. Play back the first track of the test disc. 2. Set SW2 of the Test Unit to E-F position. 3. Adjust VR101 so that the center level of the waveform is within the range of $0\text{ V} \pm 0.1\text{ V DC}$ as shown below: <div style="text-align: center;">  <p>Center Level</p> </div> <p>Oscilloscope Setting: DC Mode, 1 V/div, 1 ms/div</p>
<p>SW1: OFF SW3: OFF SW2: E-F Filter: OUT</p> <div style="text-align: center;">  <p>Connecting Diagram</p> </div> <ol style="list-style-type: none"> 4. Set SW2 to OFF position. 					
6	Tracking Gain Adjustment	Philips Test Sample 5	Oscillator to OSC Connector of Test Unit Oscilloscope to Test Unit o CH1 to X o CH2 to Y	VR104	<ol style="list-style-type: none"> 1. Set the output of oscillator to 1.2kHz, 0.1Vrms without connecting any load. 2. Connect the oscillator output to OSC connector of the Test Unit. 3. Set the Filter switch of the Test Unit to IN position. 4. Play back the first track of the test disc. 5. Set SW3 of the Test Unit to TRACKING position. 6. Adjust VR104 so that the amplitude of both waveforms on the oscilloscope are equal. ($a=b$) 7. Set SW3 to OFF position.
<p>SW1: OFF SW3: TRACKING SW2: OFF Filter: IN</p> <div style="display: flex; justify-content: space-around;"> <div style="text-align: center;">  <p>Connecting Diagram</p> </div> <div style="text-align: center;"> <p>Good waveforms</p>  <p>CH1 CH2</p> <p>$a=b$</p> </div> <div style="text-align: center;"> <p>NG waveforms</p>  </div> </div> <p>Oscilloscope Setting: CH1, CH2: 0.2 V/div, DC Mode Time: 0.5 ms/div Mode: Auto, ALT Trigger: CH1</p>					

STEP	ITEM	SIGNAL SOURCE	OUTPUT CONNECTION	ADJUSTMENT	REMARKS
7	Focus Gain Adjustment	Philips Test Sample 5	Oscillator to OSC connector of Test Unit Oscilloscope to Test Unit o CH1 to X o CH2 to Y	VR103	<ol style="list-style-type: none"> Set the output of oscillator to 800Hz, 0.1Vrms without connecting any load. Connect the oscillator output to OSC connector of the Test Unit. Set the Filter switch of the Test Unit to IN position. Play back the first track of the test disc. Set SW3 of the Test Unit to FOCUS position. Adjust VR103 so that the amplitude of both waveforms on the oscilloscope are equal. (a=b) Set SW3 to OFF position. Set the Filter switch to OUT position. After adjustment, perform "EFM Signal Adjustment" in Step 4.
<p>SW1: OFF SW3: FOCUS SW2: OFF Filter: IN</p> <p style="text-align: center;">Good waveforms NG waveforms</p> <div style="display: flex; justify-content: space-around; align-items: flex-start;"> <div style="text-align: center;">  <p>Connecting Diagram</p> </div> <div style="text-align: center;">  <p>a=b</p> </div> <div style="text-align: center;">  </div> </div> <p style="text-align: center;">Oscilloscope Setting: CH1, CH2: 0.2 V/div, DC Mode Time: 0.5 ms/div Mode: Auto, ALT Trigger: CH1</p>					
8	Distortion Adjustment	Sony YEDS-7 (Type 3)	Distortion Meter to Output Jack	VR107(Lch) VR106(Rch)	<ol style="list-style-type: none"> Play back the 19th program (1kHz, -20dB) of the test disc. Adjust VR107 (Lch) and VR106 (Rch) to obtain minimum distortion.
9	Operation Check	Philips Test Sample 5A			<p>Play back the following test programs on the test disc (Philips Test Sample 5A) and make sure that there is no noise and track-jumping.</p> <ul style="list-style-type: none"> o Interruption 700 μm 8th program 0'00" - 0'20" o Black Dot 600 μm 14th program 0'00" - 0'20" o Simulated fingerprint 20th program 0'00" - 0'20"

6. MECHANISM ASS'Y AND PARTS LIST

6.1. Synthesis

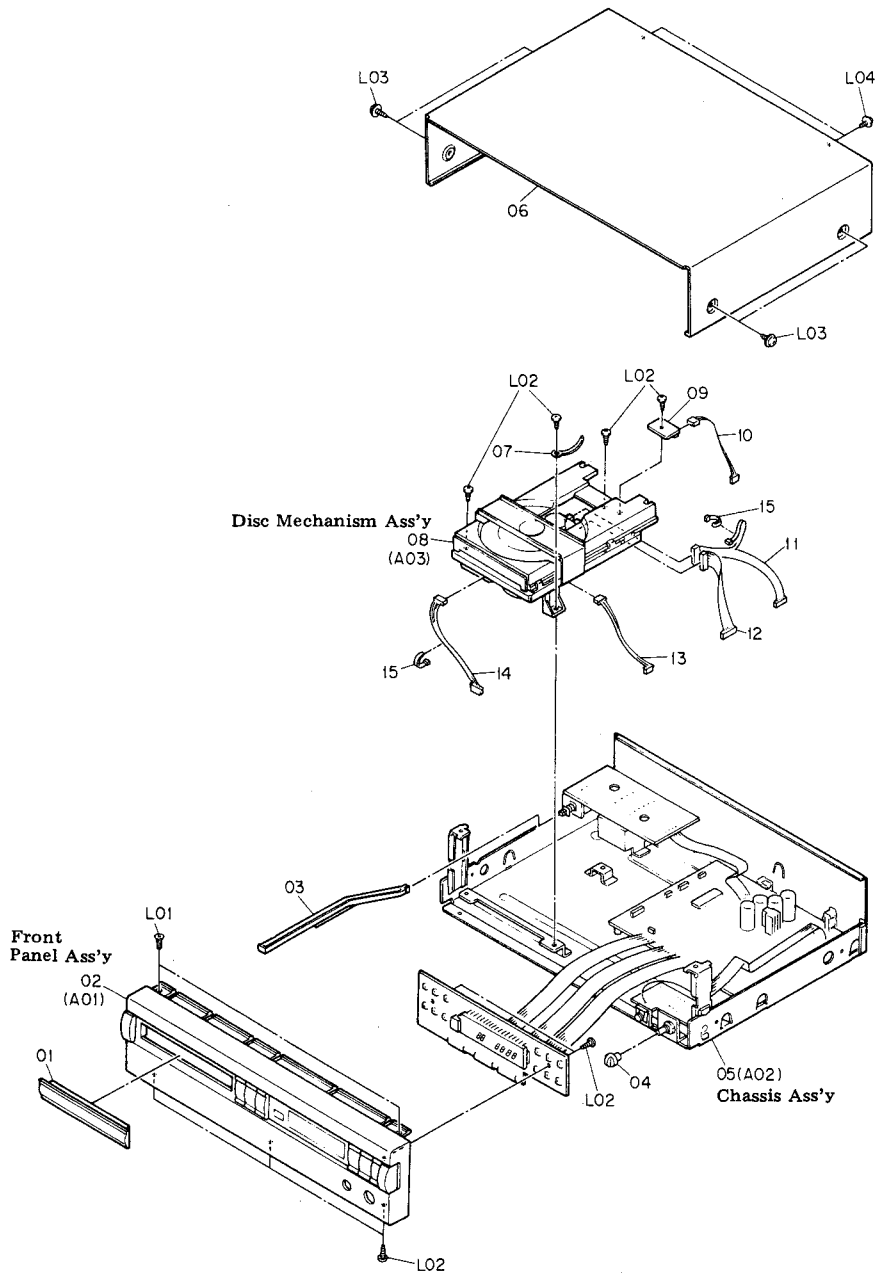

Fig. 6.1

*: Unstocked parts.

Schematic Ref. No.	Part No.	Description	Qty	Schematic Ref. No.	Part No.	Description	Qty
6.1. Synthesis				12	0B83839A	Ribbon Cable Ass'y 8P 150	1
				13	0B83847A	4P-H Connector Ass'y 270	1
				14	0B83840A	5P-H Connector Ass'y 300	1
				15	0B90019A	Insu-Lock	2
01	HA05820A	Disc Tray Cover Ass'y	1	L01	0E03025A	BT3x6 @ Countersunk	
02	HA05821A	Front Panel Ass'y	1	L02	0E00921A	BT3x8 @ Binding (Black Chromate)	
03	0J06148A	Power Switch Joint	1	L03	0E03032A	BT4x8 @ Pan Washer-Faced (Black Chromate)	
04	0H05711A	Headphone Volume Knob	1	L04	0E03632A	BT3x8 @ Binding with Washer (Black Chromate)	
05	—	Chassis Ass'y	1				
06	HA05819A	Top Cover Ass'y	1				
07	0J06068A	Wire Clamper	1				
08 *	CA08991A	Disc Mechanism Ass'y	1				
09 *	BA07842A	Sub P.C.B. Ass'y	1				
10	0B83864A	3P-H Connector Ass'y 150	1				
11	0B83838A	Ribbon Cable Ass'y 8P 200	1				

6.2. Front Panel Ass'y (A01)

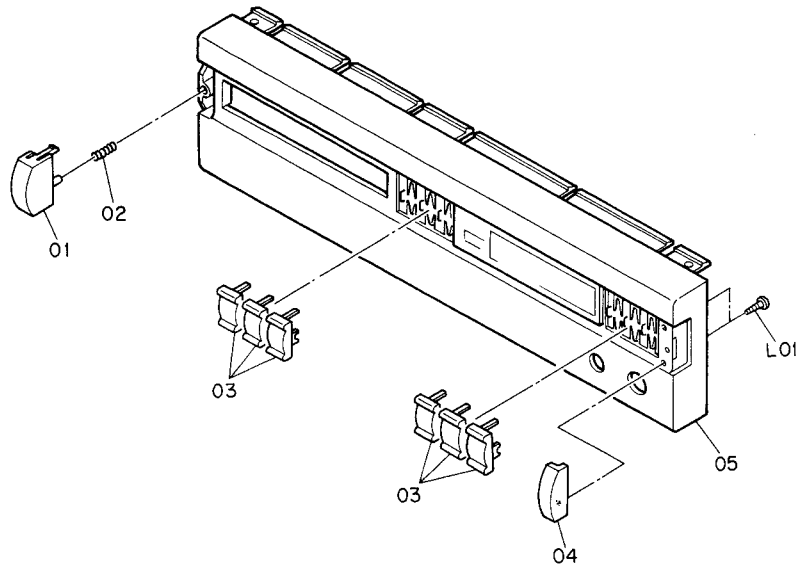

Fig. 6.2

*: Unstocked parts.

Schematic Ref. No.	Part No.	Description	Q'ty	Schematic Ref. No.	Part No.	Description	Q'ty
6.2. Front Panel Ass'y (A01)							
A01	HA05821A	Front Panel Ass'y	1	14	0B90283A 0H05764A	Cord Bushing (OTR, JPN) Rear Plate (USA, CAN, EP, AUS, JPN)	1 1
01	0H05723A	Power Switch Button	1	15	0H05722A	Rear Plate (OTR)	1
02	0C09392A	Power Switch Spring	1	L01	0M05611A	Voltage Lock Plate (OTR)	1
03	0H05716A	Control Knob A	6	L02	0E03157A	BT3x8 @ Binding With Washer	1
04	0H05714A	Dummy Cap	1	L03	0E03592A	BT4x6 @ Binding Washer-Faced	
05	—	Front Panel Sub Ass'y	1		0E00921A	BT3x8 @ Binding (Black Chromate)	
L01	0E00855A	BT2x6 @ Binding		L04	0E00612A	M3x6 @ Pan (2A)	
6.3. Chassis Ass'y (A02)				L05	0E00888A	BT3x12 @ Binding	
A02	—	Chassis Ass'y	1	L06	0E03365A	BT3x8 @ Binding Projected	
01	* BA08005A	Main P.C.B. Ass'y (USA, EP, AUS, OTR, JPN) Serial No.: V31307634 -	1	L07	0E00985A	M3x6 @ Binding (Black Chromate) (OTR)	
	* BA07805A	Main P.C.B. Ass'y (USA) Serial Nos.: V31301034 - 07633	1				
	* BA07805A	Main P.C.B. Ass'y (CAN)	1				
02	0B90019A	Insu-Lock	1				
03	* BA07808A	Power Switch P.C.B. Ass'y (USA, CAN)	1				
	* BA07942A	Power Switch P.C.B. Ass'y (AUS, EP)	1				
	* BA07975A	Power Switch P.C.B. Ass'y (OTR)	1				
	* BA07939A	Power Switch P.C.B. Ass'y (JPN)	1				
04	0B50166A	Power Transformer (USA, CAN)	1				
	0B50168A	Power Transformer (EP)	1				
	0B50169A	Power Transformer (AUS)	1				
	0B50167A	Power Transformer (OTR)	1				
	0B50165A	Power Transformer (JPN)	1				
05	0B71012A	Power Switch [S001]	1				
06	0J06147A	Power Switch Angle	1				
07	—	Chassis Base Ass'y	1				
08	HA05833A	Leg Ass'y	4				
09	* BA07807A	Control & Display P.C.B. Ass'y	1				
10	0J05092A	Snap Plate	1				
11	* BA07806A	Headphone Amp. P.C.B. Ass'y	1				
12	0B80314A	Power Cord SPT-2 (USA, CAN)	1				
	0B08093U	Power Cord (EP)	1				
	0B05241A	Power Cord (AUS)	1				
	0B08533A	Power Cord (OTR)	1				
	0B08219B	Power Cord (JPN)	1				
13	0B90280A	Cord Bushing (USA, CAN, EP, AUS)	1				

6.3. Chassis Ass'y (A02)

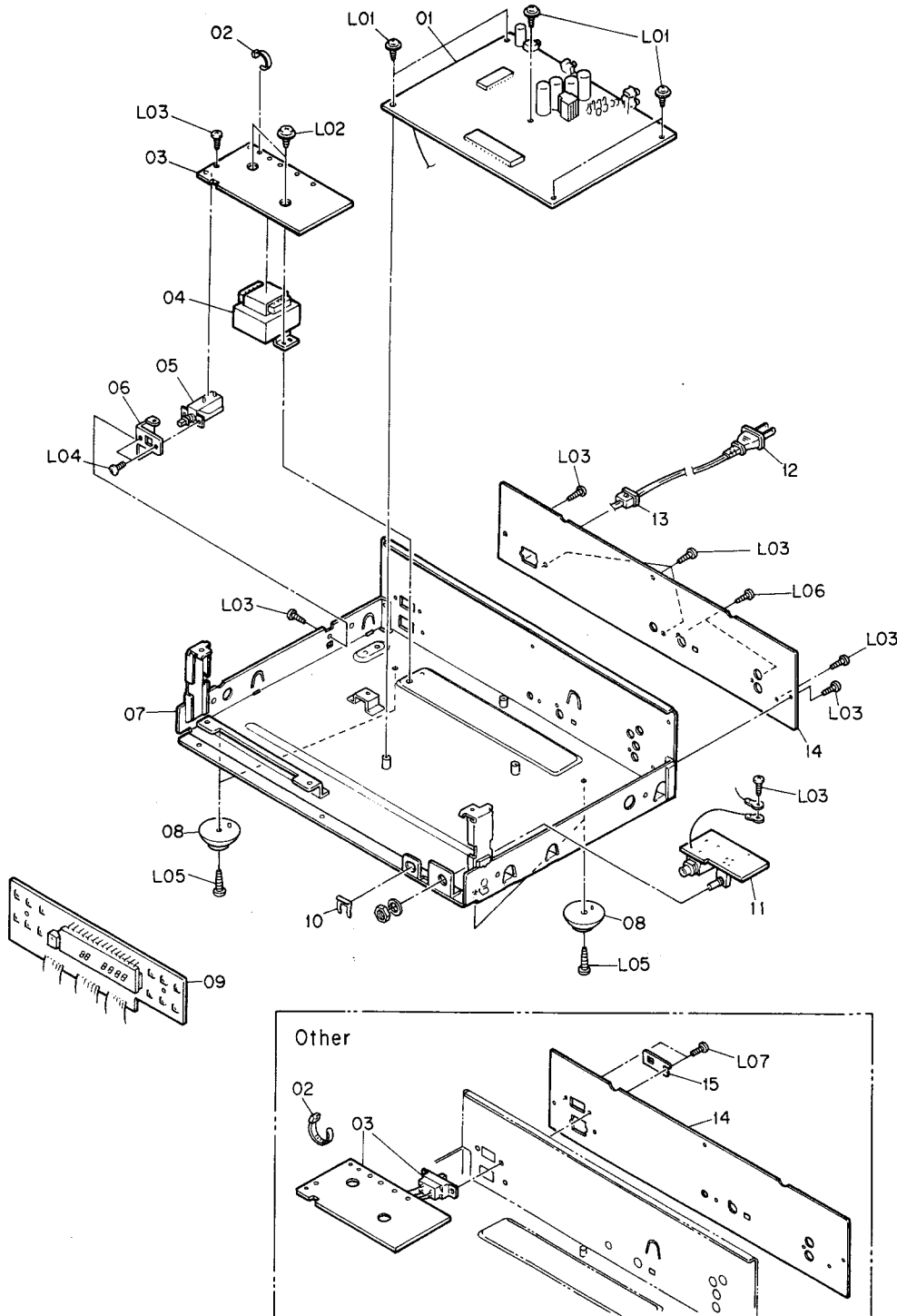

Fig. 6.3

6.4. Disc Mechanism Ass'y (A03)

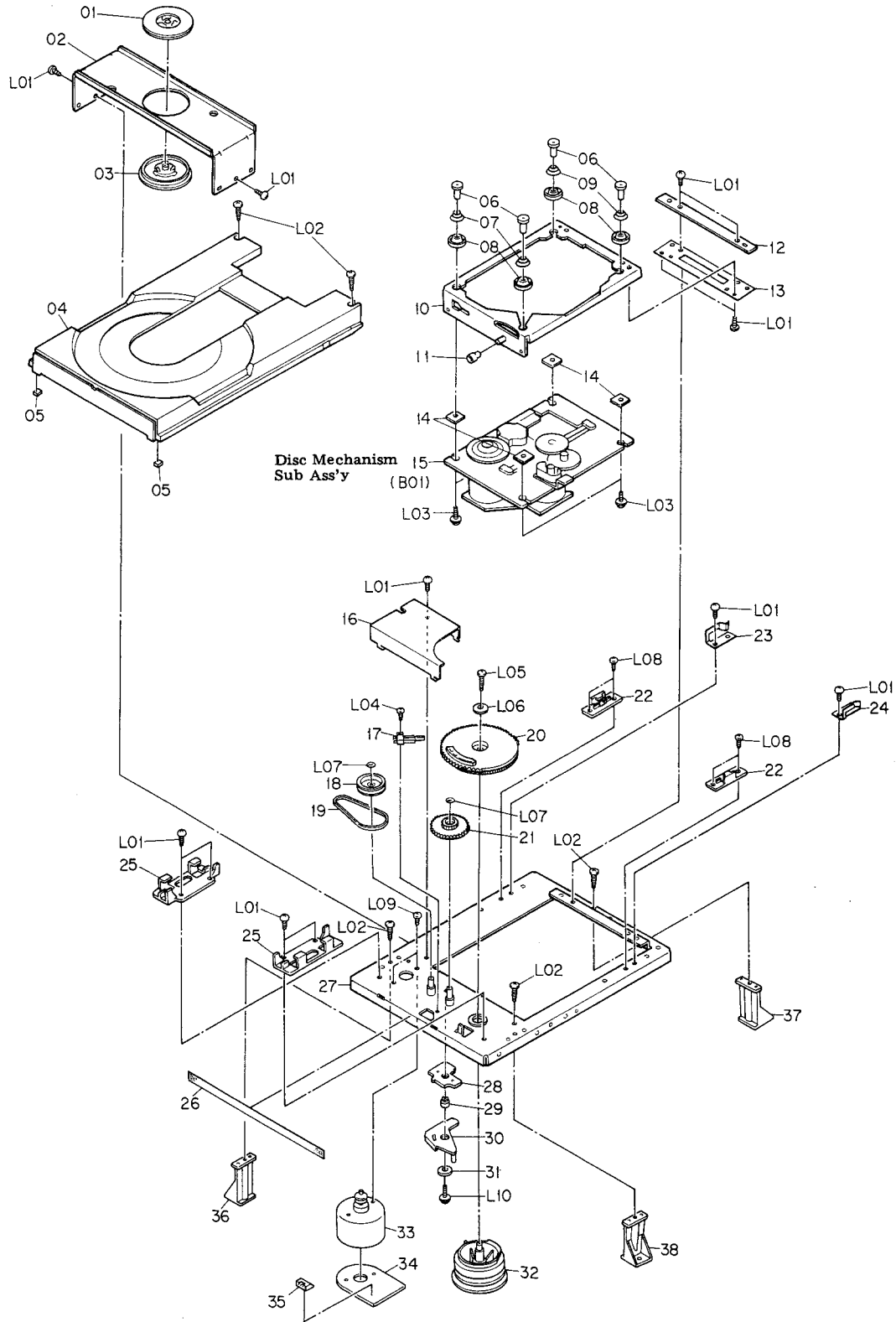

Fig. 6.4

6.5. Disc Mechanism Sub Ass'y (B01)

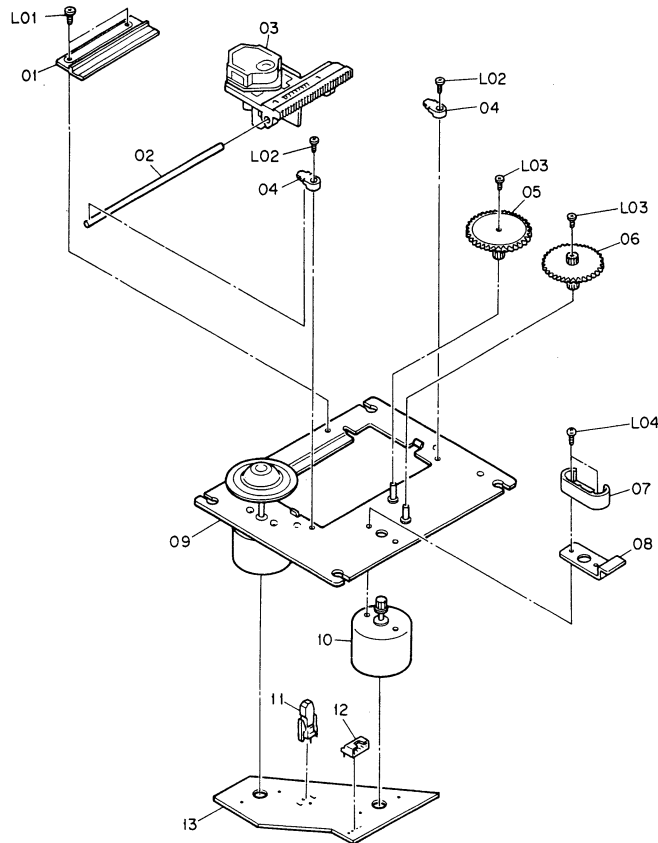

Fig. 6.5

*: Unstocked parts.

Schematic Ref. No.	Part No.	Description	Q'ty	Schematic Ref. No.	Part No.	Description	Q'ty
6.4. Disc Mechanism Ass'y (A03)				36	OC85241A	MD Holder Left	1
				37	OC85240A	MD Holder Rear	1
				38	OC85239A	MD Holder Right	1
A03	* CA08991A	Disc Mechanism Ass'y	1	L01	OE03594A	ST2.6x6 @ Brazier	
01	OC85220A	Magnet Ass'y	1	L02	OE03596A	ST3x10 @ Binding (Black Chromate)	
02	OC85221A	Chuck Chassis	1	L03	OC85219A	Screw Washer Head	
03	OC85222A	Chucking Pulley	1	L04	OE03566A	ST2x4 @ Brazier	
04	OC85223A	Disc Tray	1	L05	OE03595A	ST2.6x10 @ Binding	
05	OC85247A	Damper	2	L06	OC85225A	Washer A	
06	OC85213A	Shaft SP	4	L07	OC85229A	Washer B	
07	OC85215A	Spring A	2	L08	OE03205A	ST2x4 @ Pan	
08	OC85216A	Insulator	4	L09	OE03202A	M2.6x3 @ Binding (Black Chromate)	
09	OC85214A	Spring B	2	L10	OE03597A	ST2.6x8 @ Pan Washer-faced	
10	OC85249A	Sub Chassis Ass'y	1	6.5. Disc Mechanism Sub Ass'y (B01)			
11	OC85217A	Roller	1	B01	—	Disc Mechanism Sub Ass'y	1
12	OC85211A	Hinge Support	1	01	OC85253A	Slide Holder	1
13	OC85212A	Hinge	1	02	OC85251A	Slide Shaft	1
14	OC85218A	Plate Spring	4	03	* OC85252A	Laser Pickup KSS-150A	1
15	—	Disc Mechanism Sub Ass'y	1	04	OC85258A	Shaft Clamp	2
16	OC85224A	Gear Cover	1	05	OC85256A	Gear A	1
17	OC85228A	Leaf Switch	1	06	OC85257A	Gear B	1
18	OC85232A	Loading Pulley	1	07	OC85254A	Gear Cover	1
19	OC85231A	Loading Belt	1	08	OC85263A	Stopper	1
20	OC85226A	Drive Gear	1	09	* OC85259A	Disc Motor Ass'y	1
21	OC85230A	Center Gear	1	10	* OC85255A	Feed Motor N Ass'y	1
22	OC85236A	Tray Holder Rear	2	11	OC85260A	Leaf Switch	1
23	OC85238A	Tray Guide Left	1	12	OC85262A	4P Connector	1
24	OC85237A	Tray Guide Right	1	13	OC85261A	Motor P.C.B.	1
25	OC85235A	Tray Holder Front	2	L01	OC85264A	Screw 2x5 Tapping	
26	OC85250A	Himelon	1	L02	OC85267A	Screw 2.6x8	
27	OC85248A	Main Chassis Ass'y	1	L03	OC85266A	Screw M1.7x3	
28	OC85242A	Link Plate	1	L04	OC85265A	Screw 2x5 @ Pan	
29	OC85243A	Boss	1				
30	OC85244A	Stopper Link Ass'y	1				
31	OC85245A	Spacer	1				
32	OC85227A	Control Cam	1				
33	OC85233A	Loading Motor Ass'y	1				
34	OC85234A	Loading Motor P.C.B.	1				
35	OC85246A	5P Connector	1				

7. MOUNTING DIAGRAMS AND PARTS LIST

Notes: 1. Mounting diagram shows a dip side view of the printed circuit board.

2. Diode is 1SS53, 1S1555, or 1SS176 unless otherwise specified.

3. Abbreviation for part name:

TR — Transistor, SiD — Silicon Diode, ZD — Zener Diode, Varicap — Variable Capacitance Diode

RK — Carbon Resistor, RM — Metal Film Resistor, RF — Fail Safe Type Resistor, RC — Cement Resistor

CE — Electrolytic Capacitor, CML — Mylar Capacitor, CC — Ceramic Capacitor, CPP — PP Capacitor,

CMM — Metalized Mylar Capacitor, CSP — Polystyrene Capacitor, C — Mica Capacitor

CT — Tantalum Capacitor

7.1. Power Switch P.C.B. Ass'y

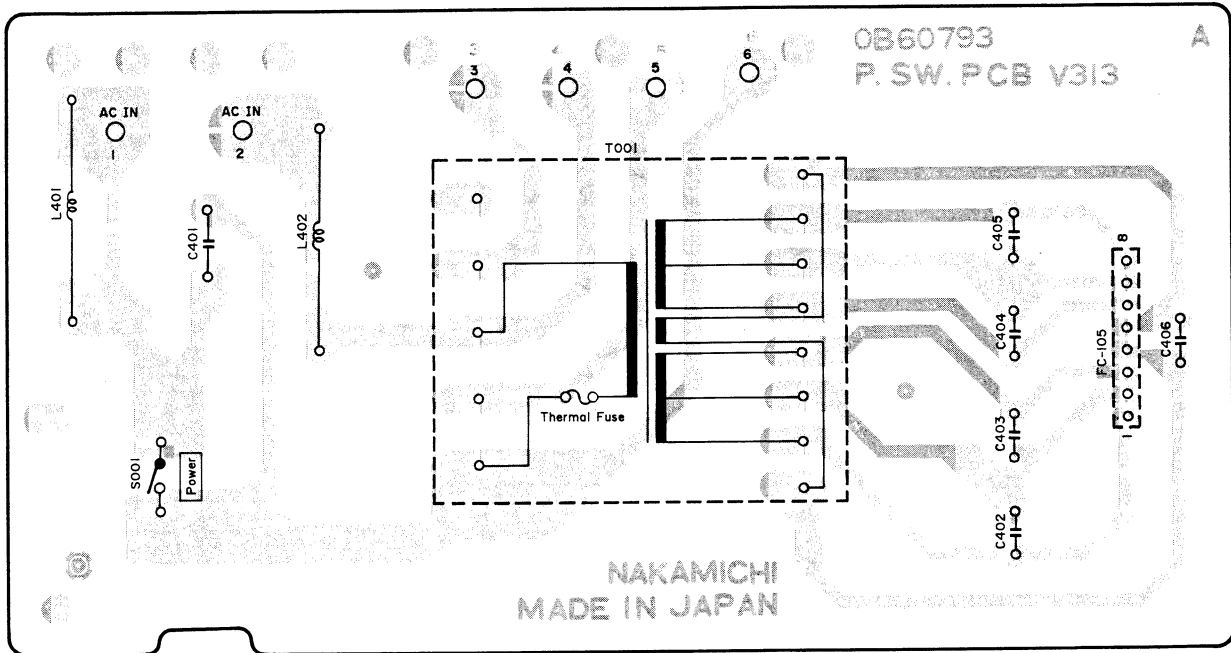

Fig. 7.1

7.2. Headphone Amp. P.C.B. Ass'y

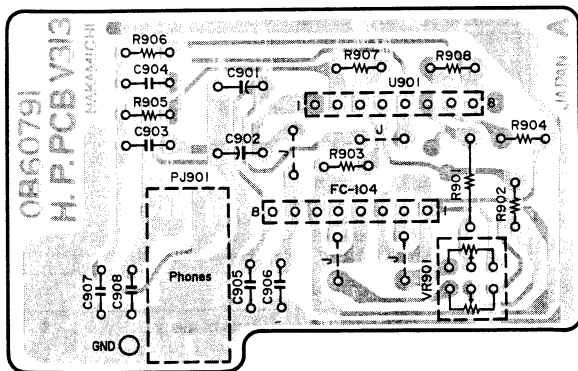

Fig. 7.2.1 2nd Version

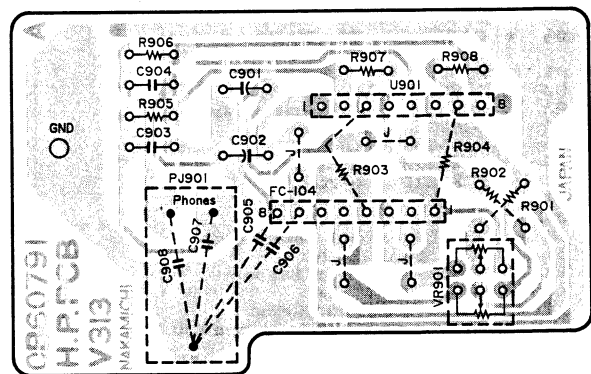

Fig. 7.2.2 1st Version

7.3. Sub P.C.B. Ass'y

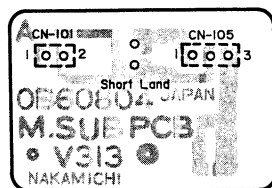

Fig. 7.3

7.4. Control & Display P.C.B. Ass'y

*: Unstocked parts.

Schematic Ref. No.	Part No.	Description
7.1. Power Switch P.C.B. Ass'y		
	* BA07808A	Power Switch P.C.B. Ass'y (USA, CAN)
	* BA07942A	Power Switch P.C.B. Ass'y (EP, AUS)
	* BA07975A	Power Switch P.C.B. Ass'y (OTR)
	* BA07939A	Power Switch P.C.B. Ass'y (JPN)
L401,402	OB51352A	Inductor 68 μ H
C401	OB41825A	CC 4700P (USA, CAN, EP, AUS, OTR)
	OB41826A	CC 4700P 250V (JPN)
C402,403	OB47117A	CC 0.1 μ 50V
C404,405	OB47117A	CC 0.1 μ 50V
C406	OB47117A	CC 0.1 μ 50V
	OE00752A	Eyelet 2x3 (EP, AUS) (2)
	OB07092U	Voltage Selector (1) (OTR)
7.2. Headphone Amp. P.C.B. Ass'y		
	* BA07806A	Headphone Amp. P.C.B. Ass'y
	OB60791A	Headphone Amp. P.C.B.
U901	OB11815A	IC NJM4556S
VR901	OB30120A	Volume 50K(A)x2
R901,902	OB09707A	RK 18K 1/6W J
R903,904	OB09709A	RK 22K 1/6W J
R905,906	OB09650A	RK 75 1/6W J
R907,908	OB09725A	RK 100K 1/6W J
C901,902	OB40078A	CE 100 μ 16V
C903,904	OB41278A	CML 2200P 50V J
C905,906	OB41971A	CC 0.1 μ 50V
C907,908	OB47139A	CC 4700P 50V
PJ901	OB81478A	Headphone Jack
7.3. Sub P.C.B. Ass'y		
	* BA07842A	Sub P.C.B. Ass'y
CN101	OE60804A	Sub P.C.B.
CN105	OB81466A	2P-S Post
	OB81467A	3P-S Post
	OE03355A	Earth Lug (1)
7.4. Control & Display P.C.B. Ass'y		
	* BA07807A	Control & Display P.C.B. Ass'y
	OB60792A	Control & Display P.C.B.
U601,602	OB11817A	IC TC5066BP
U603	OB11817A	IC TC5066BP
D601,602	OB06398A	SID 1SS176
D603,604	OB06398A	SID 1SS176
R601,602	OB09717A	RK 47K 1/6W J
R603,604	OB09717A	RK 47K 1/6W J
R605,606	OB09717A	RK 47K 1/6W J
R607,608	OB09717A	RK 47K 1/6W J
R609,610	OB09717A	RK 47K 1/6W J
R611,612	OB09717A	RK 47K 1/6W J
R613,614	OB09717A	RK 47K 1/6W J
R615,616	OB09717A	RK 47K 1/6W J
R617,618	OB09717A	RK 47K 1/6W J
R619,620	OB09717A	RK 47K 1/6W J
R621	OB09717A	RK 47K 1/6W J
R622	OB09677A	RK 1K 1/6W J
C601	OB40158A	CE 100 μ 6.3V
RS601	OB19016A	Remote Control Receiver
S601,602	OB70161A	Tact Switch
S603,604	OB70161A	Tact Switch
S605,606	OB70161A	Tact Switch
S607,608	OB70161A	Tact Switch
S609,610	OB70161A	Tact Switch
S611,612	OB70161A	Tact Switch
FL601	OB90440A	FL Tube
	OJ06219B	FL Cushion (2)
	OJ06238A	FL Stopper (2)

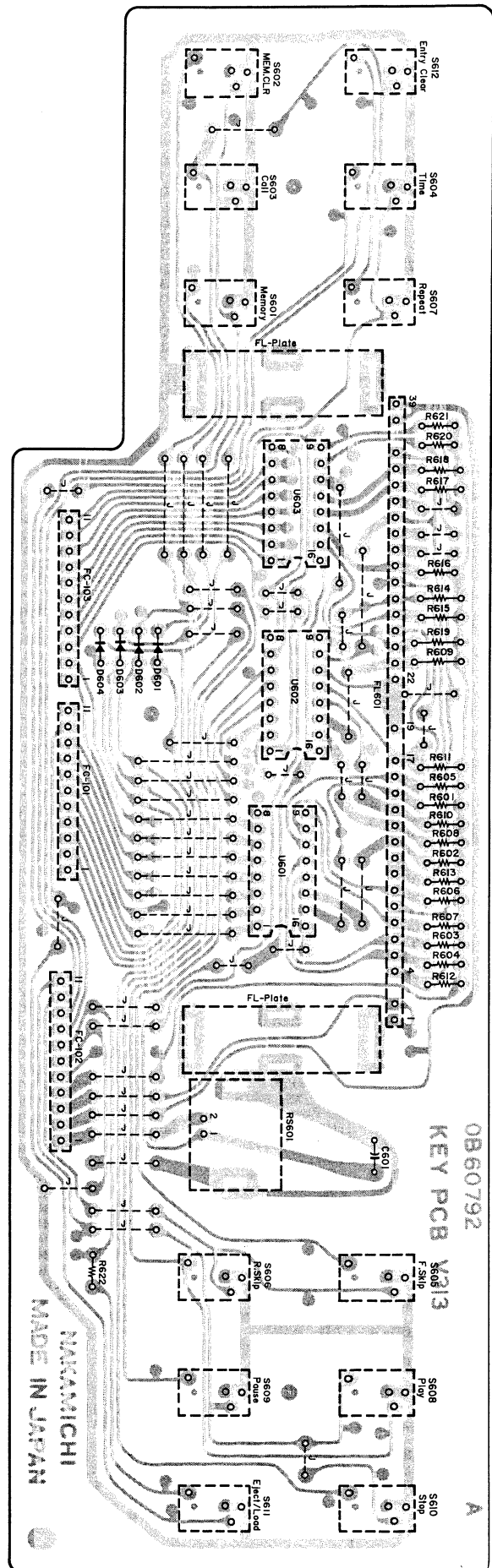

Fig. 7.4

Schematic Ref. No.	Part No.	Description
C156,157	OB40678A	CE 220μ 10V (LN)
C158,159	OB41294A	CML 0.047μ 50V J
C160,161	OB47114A	CPP 0.027μ 100V G
C162,163	OB09820A	CPP 1200P 100V G
C164,165	OB41816A	CSP 220P 160V J
C166,167	OB41653A	CFP 3900P 100V J
C168,169	OB40474A	CE 47μ 16V (BP)
C170,171	OB41772A	CSP 1000P 160V J
C172,173	OB41975A	CC 10P 50V J
C174	OB47117A	CC 0.1μ 50V Z
C175	OB41274A	CML 1000P 50V J
C176,177	OB40675A	CE 3300μ 25V
C178,179	OB40679A	CE 100μ 25V
C180,181	OB40679A	CE 100μ 25V
C182,183	OB41823A	CML 0.01μ 50V J
C184,185	OB47117A	CC 0.1μ 50V Z
C186,187	OB47117A	CC 0.1μ 50V Z
C188	OB40116A	CE 10μ 50V
C189	OB41555A	CC 0.047μ 25V Z
C190,191	OB41823A	CML 0.01μ 50V J
C192,193	OB40675A	CE 3300μ 25V
C194,195	OB40545A	CE 100μ 16V
C196,197	OB40545A	CE 100μ 16V
C198,199	OB40678A	CE 220μ 10V (LN)
C200,201	OB40678A	CE 220μ 10V (LN)
C202	OB40108A	CE 1000μ 35V
C203	OB40120A	CE 100μ 50V
C204	OB40108A	CE 1000μ 35V
C205,206	OB41823A	CML 0.01μ 50V J
C207,208	OB41823A	CML 0.01μ 50V J
C209	OB41933A	CC 15P
C211	OB41971A	CC 0.1μ 50V Z
C212	OB40707A	CE 330μ 10V
C213,214	OB41971A	CC 0.1μ 50V Z
C215,216	OB40077A	CE 47μ 16V
C217	OB41553A	CC 0.01μ 25Z
C218	OB41709A	CC 47P 50V J
C220,221	OB40116A	CE 10μ 50V
S101	OB70165A	Slide Switch
TF101,102	OB90322A	Thermal Fuse 126
TF103-107	OB90322A	Thermal Fuse 126 (CAN)
	OB90332A	Thermal Fuse 126 (USA)
		Serial Nos.: V31301034 - 07633
TP101	OB84224A	13P-T Post
TP102	OB02233A	2P-T Post
PJ101	OB84028A	Stereo Jack
		HSJ0912-01-020
PJ102	OB84226A	2P Mount Pin Jack
PJ103	OB84227A	1P Mount Pin Jack
CN101	OB81463A	6P-T Post
CN102	OB81465A	8P-T Post
CN103	OB81461A	4P-T Post
CN104	OB81462A	5P-T Post
CN105	OB81460A	3P-T Post
FC101,102	OB883835B	Flat Cable 11P 260
FC103	OB883835B	Flat Cable 11P 260
FC104	OB883837B	Flat Cable 8P 350
FC105	OB883834B	F. Cable 8P 260
	OB883923A	GND Wire Ass'y D
		(1)
	OB90448A	Heat Sink (1)

● Semiconductor Location

Ref. No.	Location
U101	G-9
U102	C-6
U103	G-4
U104	D-4
U105	H-2
U106	H-1
U107	E-7
U108	E-2
U109	G-2
U110	D-2
U111	C-2
U112	B-2
U113	C-5
U114	B-4
U115	H-7
U116	A-7
Q101	E-10
Q102	C-9
Q103	C-9
Q104	C-9
Q105	C-9
Q106	D-9
Q107	D-9
Q108	B-9
Q109	B-9
Q110	G-7
Q111	G-7
Q112	G-3
Q113	A-10
Q114	D-7
Q115	E-2
Q116	E-2
Q117	D-1
Q118	E-1
Q119	D-1
Q120	C-2
Q121	C-1
Q122	A-2
Q123	A-1
Q124	A-4
Q125	A-4
Q126	B-4
Q127	B-4
Q128	A-7
Q129	H-3
Q130	H-3
Q131	D-6
Q132	A-2
Q133	A-1
IP101	E-3
IP102	D-5
IP103	C-6
IP104	A-9
IP105	A-5
IP106	B-5
ZD101	D-1
ZD102	A-9
ZD103	A-4
ZD104	A-4
ZD105	B-4
ZD106	B-4
ZD107	A-9
D101	D-9
D102	G-2
D103	G-2
D104	G-2
D105	G-1
D106	D-3
D107	D-1
D108	A-2
D109	A-1
D110	C-1
D111	B-6
D112	B-6
D113	B-6
D114	B-6
D115	A-6
D116	A-6
D117	B-6
D118	B-6
D119	A-8
D120	A-8
D121	H-3
D122	H-3
D123	H-3
D124	H-3
D125	E-1

7.5. Main P.C.B. Ass'y

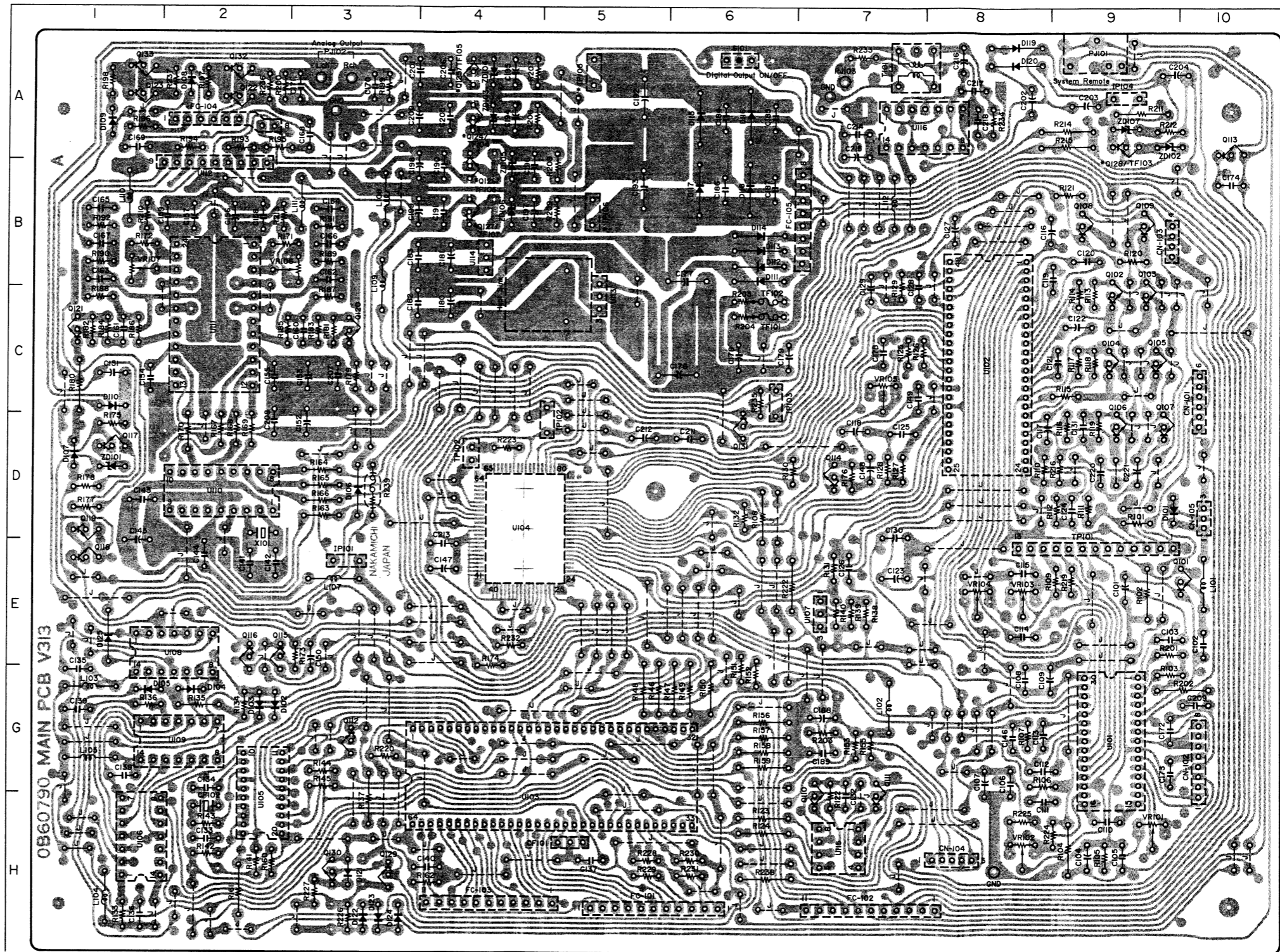

Thermal fuses (TF103-TF107) are mounted on the transistors as shown below:

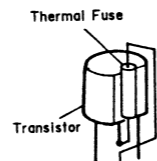

Fig. 7.5.1 For Serial No.: V31307634 -

NOTE: Parts marked with * (TF103-TF107, IP105, IP106) are mounted as follows.

Destination	TF103-TF107	IP105, IP106
CAN	Mounted.	Not mounted.
USA, EP AUS, OTR JPN	Not mounted.	Mounted.

● Semiconductor Location

Ref. No.	Location
U101	G-9
U102	C-6
U103	G-4
U104	D-4
U105	H-2
U106	H-1
U107	E-7
U108	E-2
U109	G-2
U110	D-2
U111	C-2
U112	B-2
U113	C-5
U114	B-4
U115	H-7
U116	A-7
Q101	E-10
Q102	C-9
Q103	C-9
Q104	C-9
Q105	C-9
Q106	D-9
Q107	D-9
Q108	B-9
Q109	B-9
Q110	G-7
Q111	G-7
Q112	G-3
Q113	A-10
Q114	D-7
Q115	E-2
Q116	E-2
Q117	D-1
Q118	E-1
Q119	D-1
Q120	C-2
Q121	C-1
Q122	A-2
Q123	A-1
Q124	A-4
Q125	A-4
Q126	B-4
Q127	B-4
Q128	A-7
Q129	H-3
Q130	H-3
Q131	D-6
Q132	A-2
Q133	A-1
IP101	E-3
IP102	D-5
IP103	C-6
IP104	A-9
ZD101	D-1
ZD102	A-9
ZD103	A-4
ZD104	A-4
ZD105	B-4
ZD106	B-4
ZD107	A-9
D101	D-9
D102	G-2
D103	G-2
D104	G-2
D105	G-1
D106	D-3
D107	D-1
D108	A-2
D109	A-1
D110	C-1
D111	B-6
D112	B-6
D113	B-6
D114	B-6
D115	A-6
D116	A-6
D117	B-6
D118	B-6
D119	A-8
D120	A-8
D121	H-3
D122	H-3
D123	H-3
D124	H-3
D125	E-1

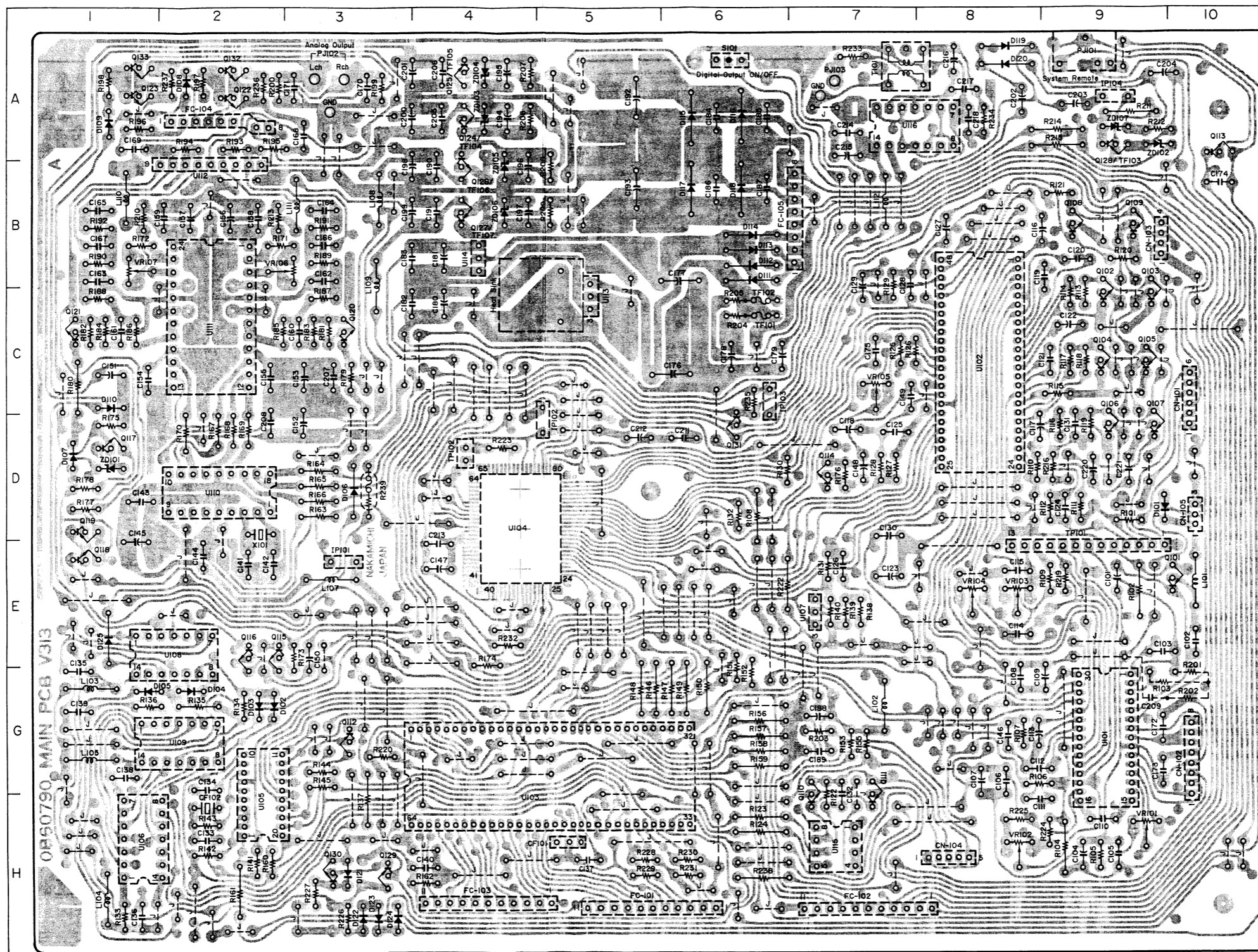

Thermal fuses (TF103-TF107) are mounted on the transistors as shown below:

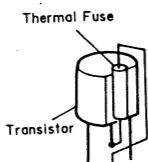

Fig. 7.5.2 For Serial Nos.: V31301034 - 07633

8. SCHEMATIC DIAGRAM

8.1. IC Block Diagrams

U101 CXA1081S (RF Amp.)

Pin No.	Signal Name	I/O	Function
1	RFI	I	EFM signal is input from the RF summing amp. through a capacitor.
2	RFO	O	EFM signal (eye pattern) output. It is output from the RF summing amp.
3	RF-	I	Feedback input to the RF summing amp.
4	P/N	I	Open. Input condition depends on the kind of laser diode to be used.
5	LD	O	Output from the APC LD (Auto Power Control for Laser Diode) amp.
6	PD	I	Input to the APC PD (Photodiode) amp.
7	PD1	I	Current input (A + C) from the photodiodes A and C of the laser pickup.
8	PD2	I	Current input (B + D) from the photodiodes B and D of the laser pickup.
9	VC	-	Grounded.
10	F	I	Current input (F) from the photodiode F of the laser pickup.
11	E	I	Current input (E) from the photodiode E of the laser pickup.
12	EO	O	E I-V amp. output.
13	EI	I	Feedback input to E I-V amp.
14	VR	O	Output voltage = $(V_{CC} + V_{EE})/2$ (Not used.)
15	CC2	I	Defect bottom hold signal input through a capacitor.
16	CC1	O	Defect bottom hold signal output.
17	VEE	I	-5 V is supplied.
18	FE Bias	I	Offset adjusting input of the focus error amp.
19	FE	O	Focus error amp. output.
20	TE	O	Tracking error amp. output.
21	DEFECT	O	Defect comparator output.
22	MIRR	O	Mirror comparator output.
23	CP	I	Mirror hold capacitor connecting pin.
24	CB	I	Defect bottom hold capacitor connecting pin.
25	DGND	-	Grounded.
26	ASY	I	EFM signal slice level control input from U104 (Digital Signal Processor).
27	EFM	O	Binary-coded EFM signal output.
28	FOK	O	Focus OK signal output.
29	LD ON	I	Laser diode ON/OFF input. Active "L".
30	VCC	I	+5 V is supplied.

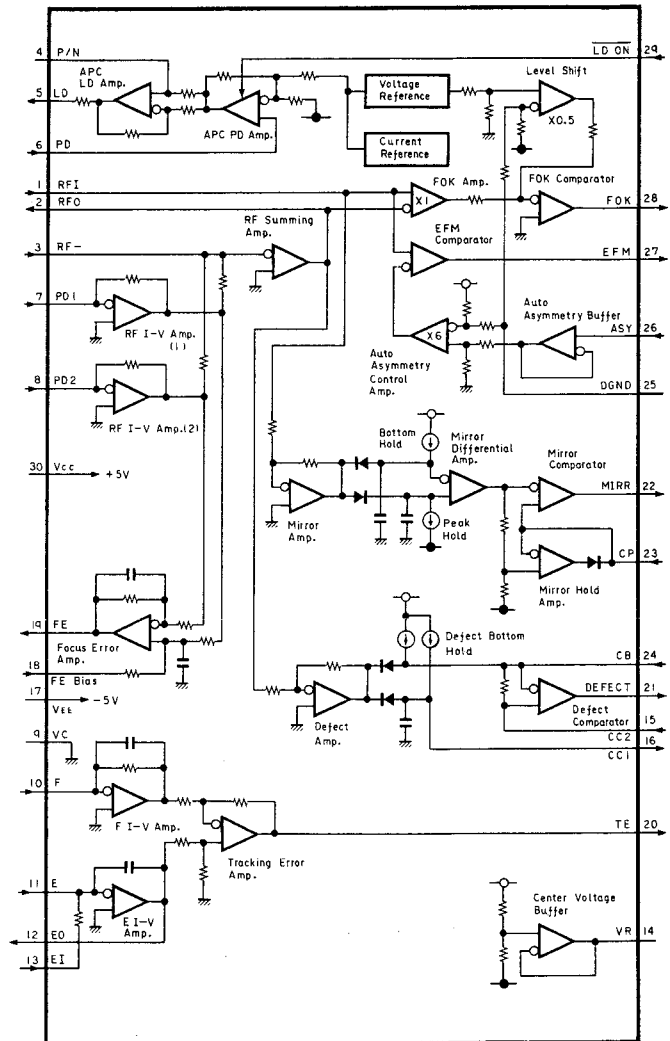
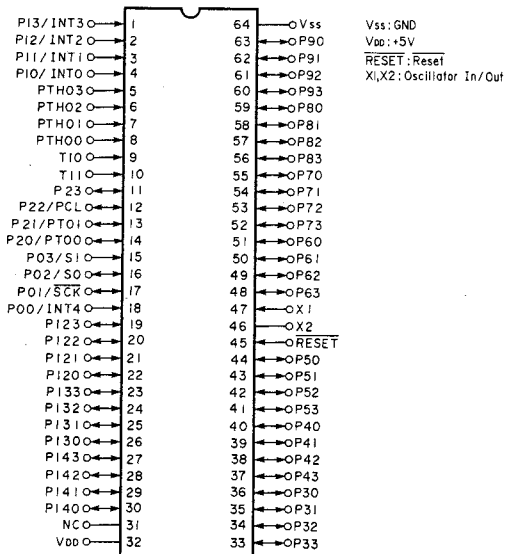
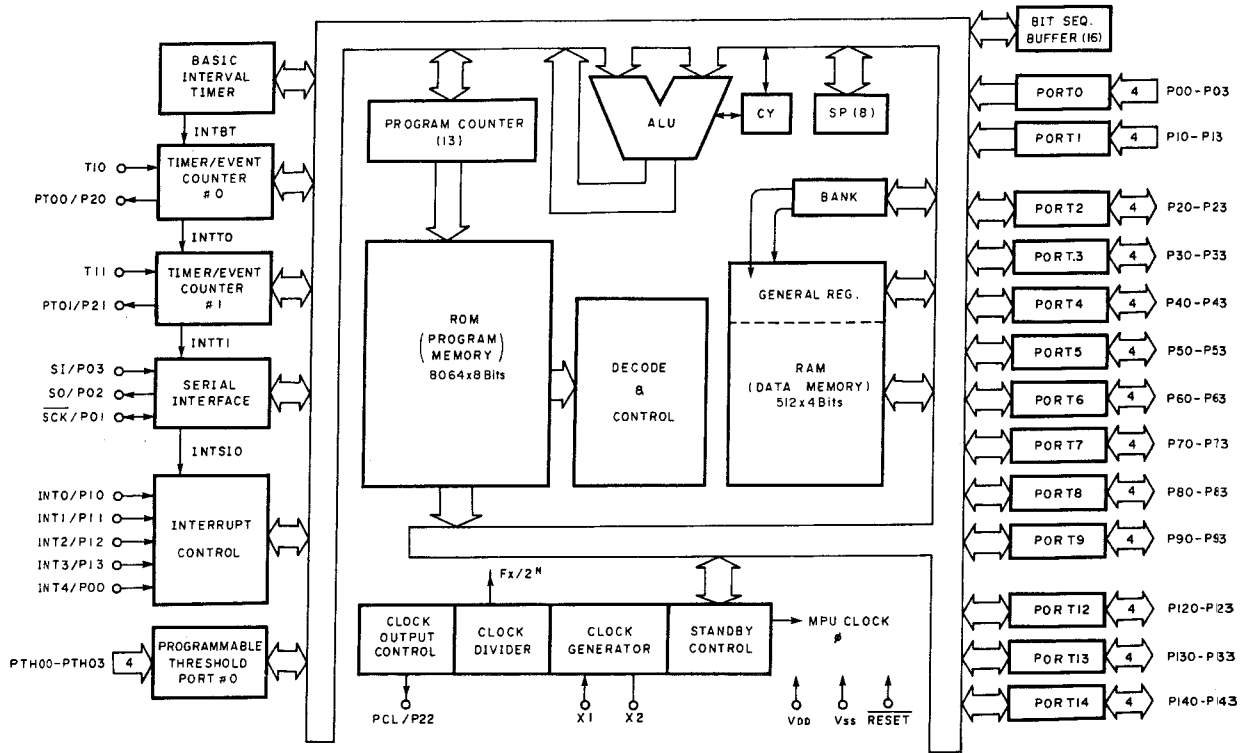

Fig. 8.1.1 RF Amp. CXA1081S (U101)

U103 μ PD75108CW-239 (MPU)

Pin No.	Signal Name	I/O	Function
1	D-STA	I	Inner switch is connected. Becomes "L" when Inner switch is ON, ie., when the laser pickup reached the inner position.
2	D-Open	I	Disc Tray Open switch is connected.
3	DCLS	I	Disc Tray Close switch is connected.
4	Eject	I	Eject/Load switch is connected. Becomes "H" when the Eject/Load switch is pressed.
5 to 9	RD0 to RD4	I	Instruction input from the Remote Control Unit via U105 (Remote Control Instruction Decoder).
10	Sense	I	Sense input form U102 (Servo Signal Processor) or U104 (Digital Signal Processor). Signal meaning varies with the command sent from this IC (MPU). However, it is the answer to the command issued.
11	IR	I	Input from U105 (Remote Control Instruction Decoder).
12	FOK	I	Focus OK signal from U101 (RF Amp.)
13	RD6	I	Input from U105 (Remote Control Instruction Decoder).
14	CRCF	I	Input from U104 (Digital Signal Processor). This signal shows the cyclic redundancy code (CRC) check result of subcode Q in U104. Check result OK: "H", NG: "L"
15	SUBQ	I	Subcode Q data input from U104.
16	—	—	Not used.
17	SQCK	I	Clock for reading the subcode Q data.
18	SCOR	I	Subcode sync (S0 + S1) input. This IC (MPU) starts to read subcode Q information (SUBQ & CRCF) synchronizing with SQCK.
19	Data	O	An 8-bit serial output to U102 (Servo Signal Processor) and U104 (Digital Signal Processor). Command is output from this pin.
20	CLK	O	Clock for Data at pin 19.
21	XLT	O	"L" pulse is output when 8-bit data is sent. This pulse is used to latch the 8-bit data.
22	—	—	Not used.
23 to 26	KIB0 to KIB3	I	Input from the key matrix (switches on the Front Panel).
27 to 30	KIA0 to KIA3	—	Not used.
31	—	—	Not used.
32	VDD	I	+5 V is supplied.
33	Play	—	Not used.
34	Pause	—	Not used.
35	$\overline{\text{LD ON}}$	O	Laser diode ON signal. Becomes "L" while reading read-in area of the compact disc after loading or when the unit is set in Play or Pause mode.

Pin No.	Signal Name	I/O	Function
36	IROK	O	System remote enable signal output.
37 to 40	T0 to T3	O	Output to the key matrix (switches on the Front Panel) and indicator control transistors.
41	$\overline{\text{MUTG}}$	O	Mute control output. Active "L".
42	EMPH	O	De-emphasis control output. This IC (MPU) knows emphasis ON/OFF condition of the compact disc through subcode Q information and controls de-emphasis control circuit in the output stage accordingly.
43	D-OSG	O	Loading motor control output.
44	D-CSG	O	Loading motor control output.
45	Reset	I	Reset input. Active "L".
46	X2	—	4 MHz oscillator is connected.
47	X1	—	
48 to 55	AA to AH	O	Indication control output for the track number indicator, mode indicators and button LEDs.
56 to 63	BA to BH	O	Indication control output for the time counter.
64	GND	—	Grounded.



(TOP VIEW)

Fig. 8.1.2 MPU μPD75108CW-239 (U103)

U102 CXA1082BS (Servo Signal Processor)

Pin No.	Signal Name	I/O	Function
1	DVEE	I	-5 V is supplied.
2	DFCT	I	Input from defect comparator in U101 (RF amp.).
3	TE	I	Tracking error signal input.
4	TZC	I	Input to the tracking zero cross comparator.
5	ATSC	—	Grounded. (Not used.)
6	FE	I	Focus error signal input.
7	VC	—	Grounded.
8	FGD	I	Reduces focus servo gain at high frequency. Capacitor is connected between this pin and pin 9.
9	FS3	O	Selects focus servo gain at high frequency by turning ON or OFF this pin.
10	FLB	I	Capacitor connecting pin for increasing the focus servo gain at low frequency.
11	FEO	O	Focus amp. output.
12	FE-	I	Feedback input to the focus amp.
13	SRCH	I	Capacitor connecting pin for producing focus search waveform.
14	TGU	I	Capacitor connecting pins for changing over the tracking gain at high frequency.
15	TG2	O	
16	AVCC	I	+5 V is supplied.
17	TAO	O	Tracking amp. output.
18	TA-	I	Feedback input to the tracking amp.
19	SL+	I	Non-inverting input of the feed motor amp.
20	SLO	O	Feed motor amp. output.
21	SL-	I	Inverting input of the feed motor amp.
22	SSTOP	I	(Not used.)
23	FSET	I	Input to determine the peak value for tracking/focus phase compensation, and f_c of CLV LPF (Constant Linear Velocity Low Pass Filter).
24	Sense	O	Sense output to U103 (MPU). Signal meaning varies with the command sent from U103 (MPU). However, it is the answer to the command received. Example: Outputs FZC (Focus Zero Cross: in focus condition) for focus search command.
25	AVEE	I	-5 V is supplied.
26	C.OUT	O	Tracking pulse output.
27	DIRC	I	One-track jump direct control input. (Not used.)
28	$\overline{\text{XRST}}$	I	Reset input. Active "L".
29	Data	I	8-bit serial data is input from U103 (MPU).
30	XLT	I	"L" pulse is input from U103 (MPU). This pulse is used to latch the 8-bit data at pin 29 (Data).
31	CLK	I	Clocks for reading Data (pin 29).

Pin No.	Signal Name	I/O	Function
32	DGND	—	Grounded.
33	BW	I	Input to determine the time-constant of the loop filter.
34	PDI	I	Phase difference compensation signal is input in order to match the VCO frequency with the EFM signal frequency.
35	ISET	I	Input to determine the amount of current on focus search, track jump and feed kick.
36	VCOF	I	VCO frequency adjusting input.
37	3.5V	O	Regulated +3.5 V is output.
38	C864	O	VCO frequency (8.64 MHz) is output.
39	LOCK	I	Input to prevent reckless run of the feed motor.
40	MDP	I	Disc motor drive input. Speed control pulse is input while in rough serve or PLL servo mode.
41	MON	I	Disc motor ON/OFF control input.
42	FSW	I	Input to determine the time-constant of the CLV LPF.
43	DVCC	I	+5 V is supplied.
44	SPDL-	I	Non-inverting input to the disc motor amp.
45	SPDLO	O	Disc motor amp. output.
46	WDCK	I	Strobe signal input from U104 (Digital Signal Processor). (88.2 kHz)
47	FOK	I	Focus OK signal input.
48	MIRR	I	Input from the mirror comparator in U101 (RF amp.)

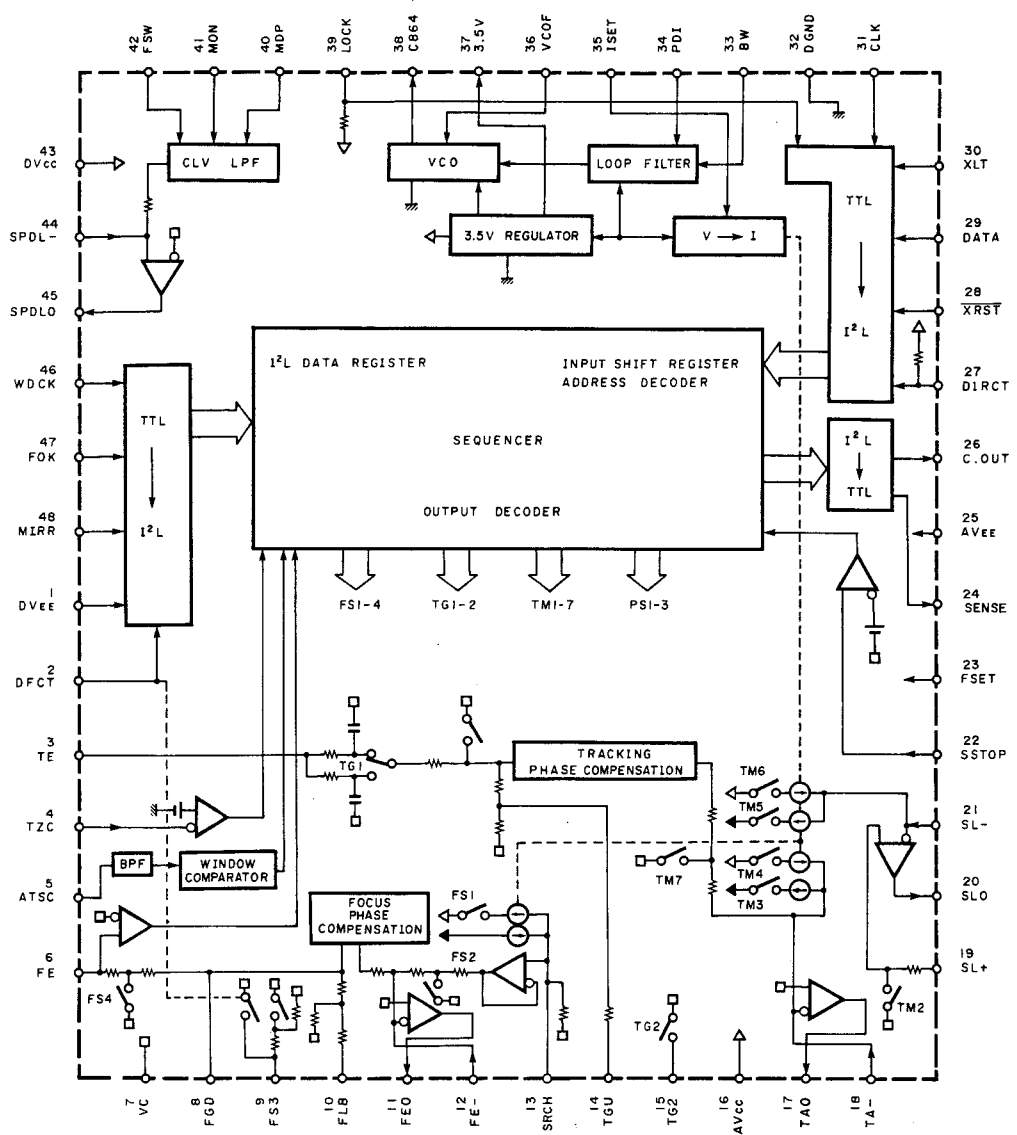

Fig. 8.1.3 Servo Signal Processor CXA1082BS (U102)

U104 CXD1167QZ (Digital Signal Processor)

Pin No.	Signal Name	I/O	Function
1	FSW	O	Output to change over the time-constant of the CLV LPF in U102 (Servo Signal Processor).
2	MON	O	Disc motor ON/OFF control output.
3	MDP	O	Disc motor drive output. Outputs a speed control pulse while in rough servo or PLL servo mode.
4	MDS	O	Disc motor drive output. Outputs a speed control pulse while in PLL servo mode.
5	EFM	I	Binary-coded EFM signal input from U101 (RF Amp.).
6	ASY	O	Output to control the slice level of the EFM signal.
7	LOCK	O	Output to prevent reckless run of the feed motor.
8	VCOO	O	VCO output. Frequency is 8.6436 MHz when locked to the clock extracted from the EFM signal.
9	VCOI	I	VCO input.
10	Test	I	Grounded. (Not used.)
11	PDO	O	Phase difference compensation signal between the clock extracted from the EFM signal and VCO/2.
12	VSS	—	Grounded.
13	CLK	I	Clocks for reading Data (pin 15).
14	XLT	I	"L" pulse is input from U103 (MPU). This pulse is used to latch the 8-bit data at pin 15 (Data).
15	Data	I	8-bit serial data is input from U103 (MPU).
16	XRST	I	Reset input. Active "L".
17	CNIN	I	Tracking pulse is input from U102 (Servo Signal Processor).
18	Sense	O	Sense output to U103 (MPU). Signal meaning varies with the command sent from U103 (MPU). However, it is the answer to the command received. Example: Informs of track-jump completion by the specified amount.
19	MUTG	I	Muting input. By combining MUTG signal with the attenuation command sent from U103 (MPU), muting is performed.
20	CRCF	O	Output of CRC check result of subcode Q data.
21	EXCK	I	Clock input to read SBSO. (Not used.)
22	SBSO	O	Subcode data serial output. (Not used.)
23	SUBQ	O	Subcode Q data output.
24	SCOR	O	Subcode sync (S0 + S1) output.
25	SQCK	O	Clock for subcode Q data.
26	SQEX	I	Fixed to "H".
27	DOTX	O	Digital output.

Pin No.	Signal Name	I/O	Function
28	GFS	O	Indicates frame sync lock condition.
29 to 32	TEST	I	Not used. Fixed to "H" or "L".
33	VDD	I	+5 V is supplied.
34 to 50	TEST	I	Not used. Fixed to "H" or "L".
51	C4M	O	Frequency (4.2336 MHz) output. Produced by dividing X'tal frequency. (Not used.)
52	VSS	—	Grounded.
53	XTAI	I	X'tal oscillating frequency input. f=16.9344 MHz
54	XTAO	O	X'tal oscillating frequency output. (Not used.)
55 56 57	MD1 MD2 MD3	I	Mode select input. (MD1="L", MD2="L" or "H", MD3="H") • Digital output ON or OFF. • Internal digital filter is not used.
58	SLOB	I	Audio data code change-over input. Fixed to "L". 2's complement is selected.
59	PSSL	I	Audio data format change-over input. Fixed to "L". Serial output is selected.
60	APTR	O	Aperture compensation control output. "H" for R channel. (Not used.)
61	APTL	O	Aperture compensation control output. "H" for L channel. (Not used.)
62 to 66	DA01 to DA05	O	(Not used.)
67	C2PO	O	Not used.
68 69	DA07 DA08	O	(Not used.)
70	PLCK	O	One-half frequency of VCO is output.
71 72	DA10 DA11	O	(Not used.)
73	VDD	I	+5 V is supplied.
74 75	DA12 DA13	O	(Not used.)
76	C2IO	O	Inversed output of the internal system clock (2.1168 MHz).
77	DA15	O	(Not used.)
78	Data	O	Demodulated serial audio data output.
79	WDCK	O	Strobe signal output to U102 (Servo Signal Processor). (88.2 kHz)
80	LRCK	O	Signal to distinguish L channel and R channel is output to U110 (Digital Filter). (44.1 kHz)

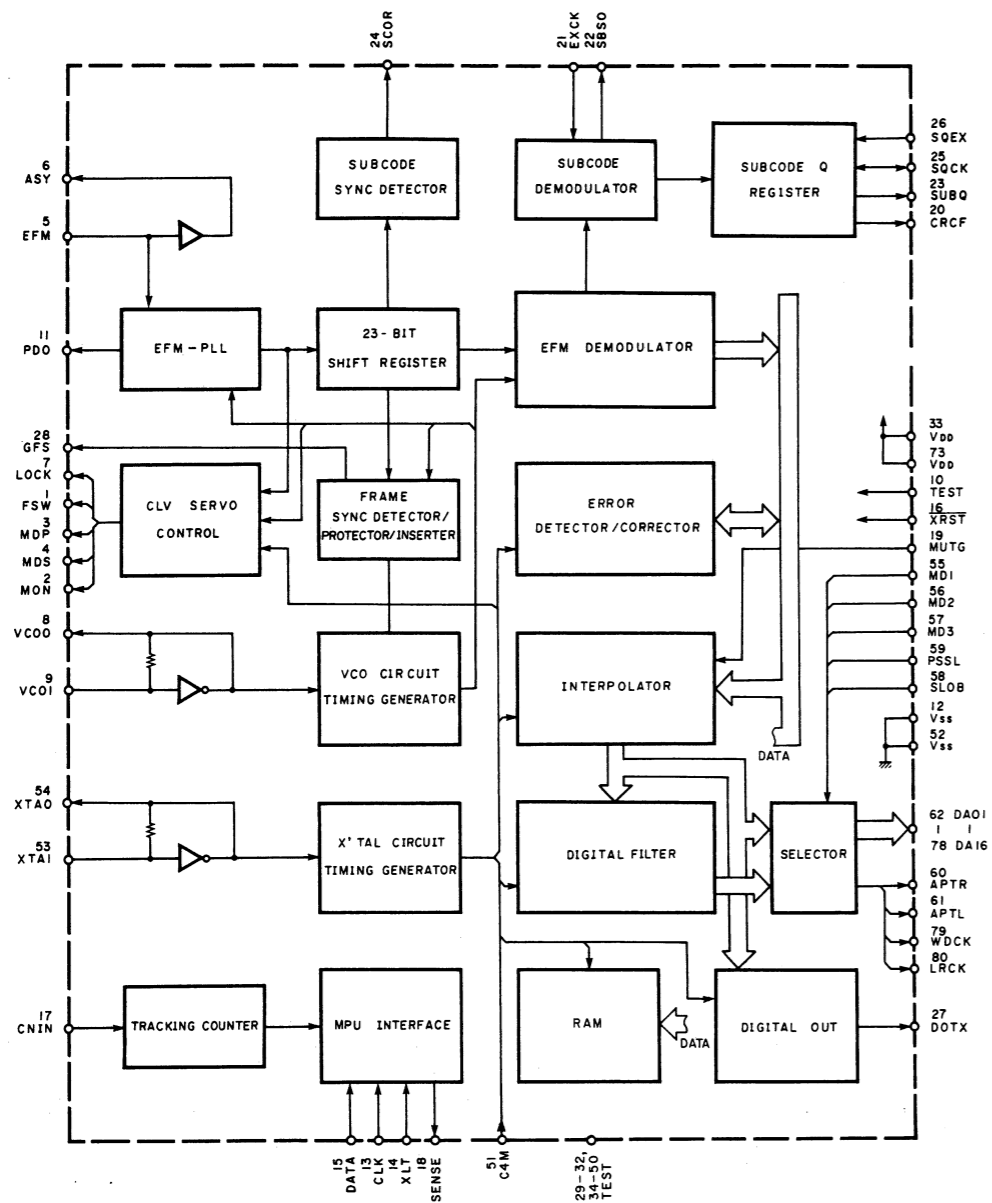

Fig. 8.1.4 Digital Signal Processor CXD1167QZ (U104)

U110 SM5840BP (Digital Filter)

Pin No.	Signal Name	I/O	Function
1	CKS	I	Frequency select input. Fixed to "H" for selecting 384 fs.
2	XTI	I	X'tal (16.9344 MHz) is connected.
3	XTO	O	
4	CKO	O	System clock output, (16.9344 MHz)
5	VSS	-	Grounded.
6	MDT	I	Not used.
7	MCK		
8	MLE		
9	RST	I	System reset input. Active "L".
10	DG	O	Deglitch output. Not used.
11	DOR	O	Rch audio data output.
12	DOL	O	Lch audio data output.
13	WCKO	O	Word clock for digitally-filtered output data.
14	VDD	I	+5 V is supplied.
15	BCKO	O	Bit clock for digitally-filtered output data.
16	LRCI	I	Sampling rate clock (fs) for input data.
17	BCKI	I	Bit clock for input data.
18	DIN	I	Serial audio data input.

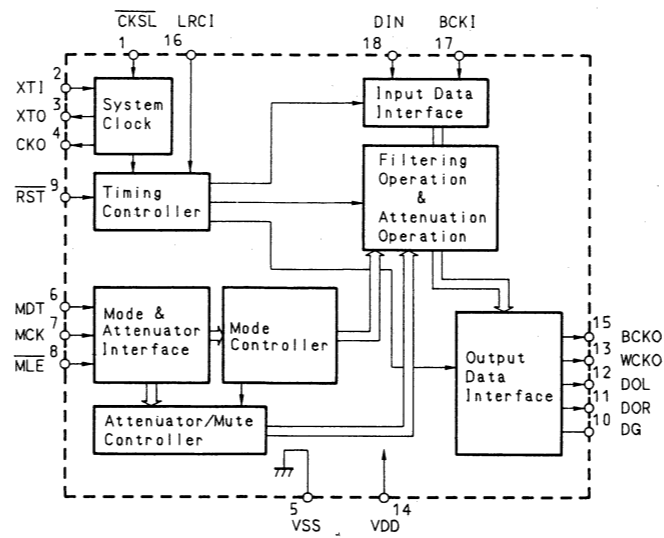

Fig. 8.1.5 Digital Filter SM5840BP (U110)

U111 AD1864N (18-Bit D/A Converter)

Pin No.	Signal Name	I/O	Function
1	-VS	I	-5 V for analog circuit.
2	Trim	I	Trim network connecting pin (Rch).
3	MSB	I	Trim potentiometer input for Rch MSB correction.
4	Iout	O	Output current (Rch).
5	AGND	-	Analog GND (Rch).
6	SJ	I	Amplifier summing junction (Rch).
7	Rf	I	Feedback input (Rch).
8	Vout	O	Output voltage (Rch).
9	VL	I	+5 V for digital circuit.
10	DR	I	Data input (Rch).
11	LR	I	Data latch input (Rch). Word clock input.
12	CK	I	Bit clock input.
13	DGND	-	Digital GND.
14	LL	I	Data latch input (Lch). Word clock input.
15	DL	I	Data input (Lch).
16	-VL	I	-5 V for digital circuit.
17	Vout	O	Output voltage (Lch).
18	RF	I	Feedback input (Lch).
19	SJ	I	Amplifier summing junction (Lch).
20	AGND	-	Analog GND (Lch).
21	Iout	O	Current output (Lch).
22	MSB	I	Trim potentiometer input for Lch MSB correction.
23	Trim	I	Trim network connecting pin (Lch).
24	Vs	I	+5 V for analog circuit.

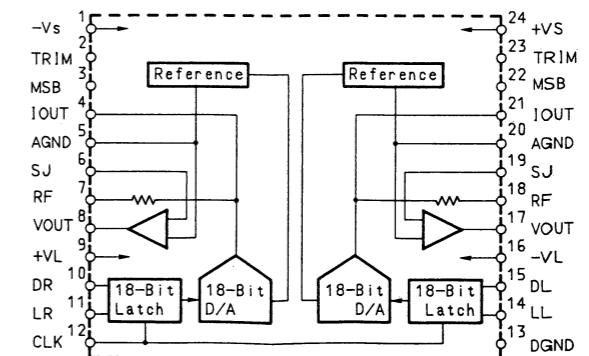

Fig. 8.1.6 18-Bit D/A Converter AD1864N (U111)

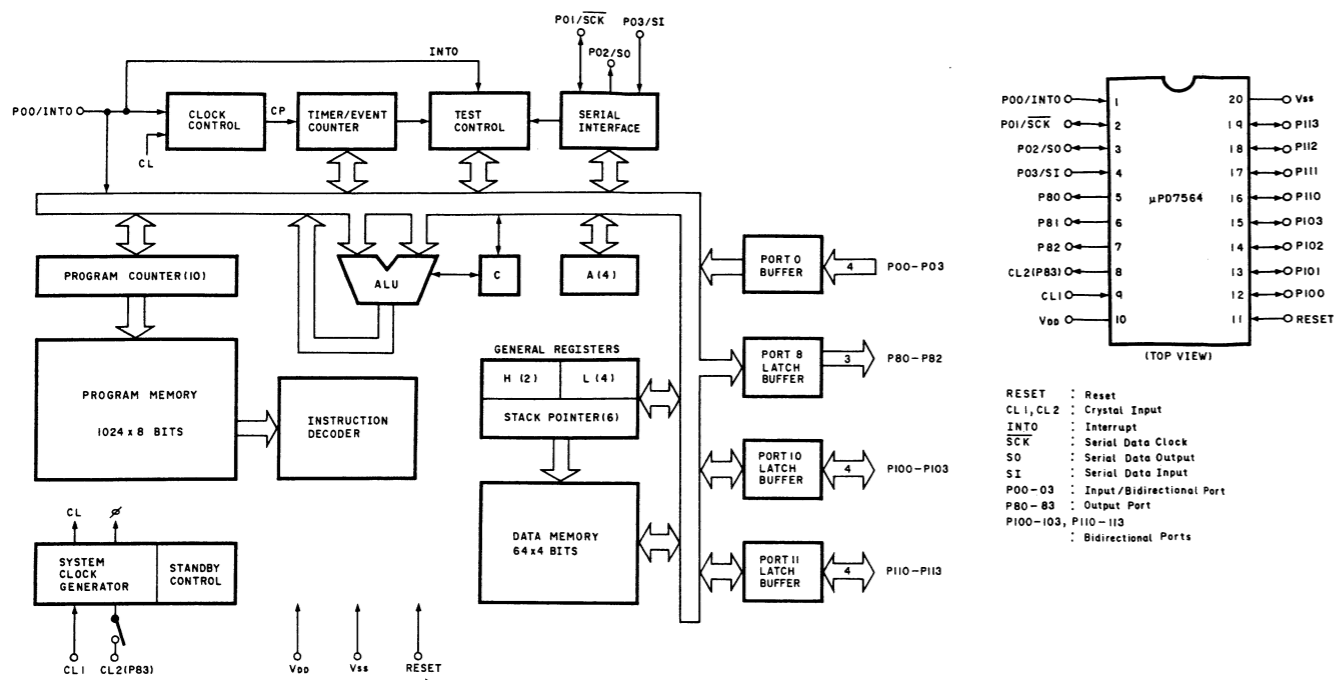

Fig. 8.1.7 Remote Control Instruction Decoder (MPU) μ PD7564CS092 (U105)

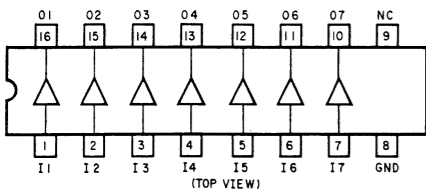

Fig. 8.1.8 Display Driver TC5066BP

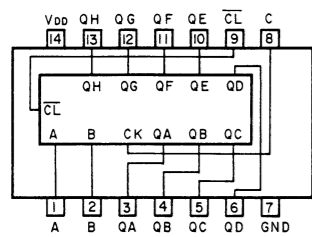

Fig. 8.1.9 3-to-8 Line Decoder TC74HC164P

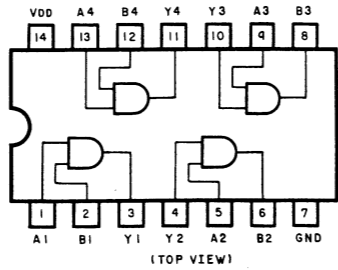

Fig. 8.1.10 AND Gate TC74HC08AP

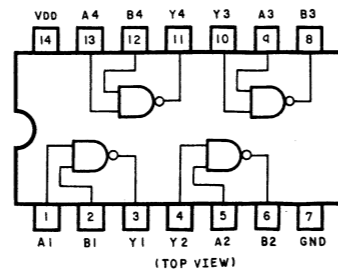

Fig. 8.1.11 NAND Gate TC74HC00AP

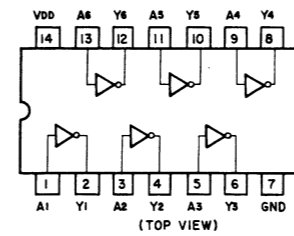

Fig. 8.1.12 Inverter IC TC74HC04AP

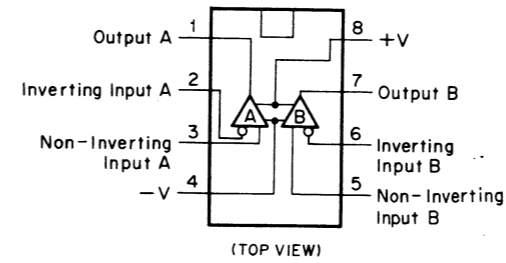

Fig. 8.1.13 Operational Amp. IC NJM4558D

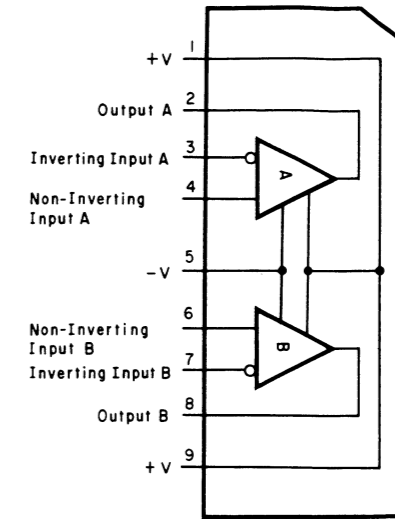

Fig. 8.1.15 Operational Amp. IC NJM5532S

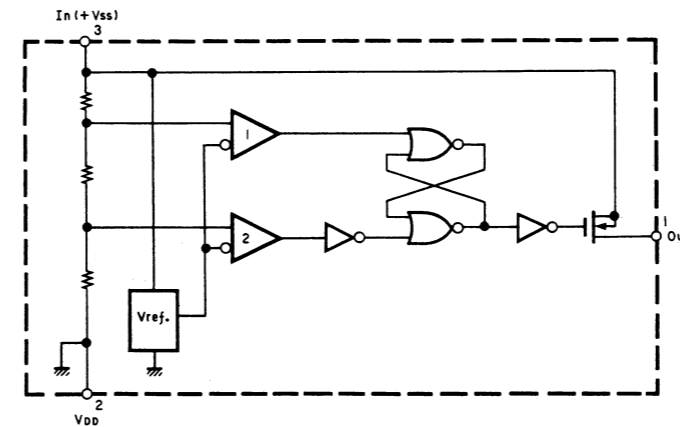
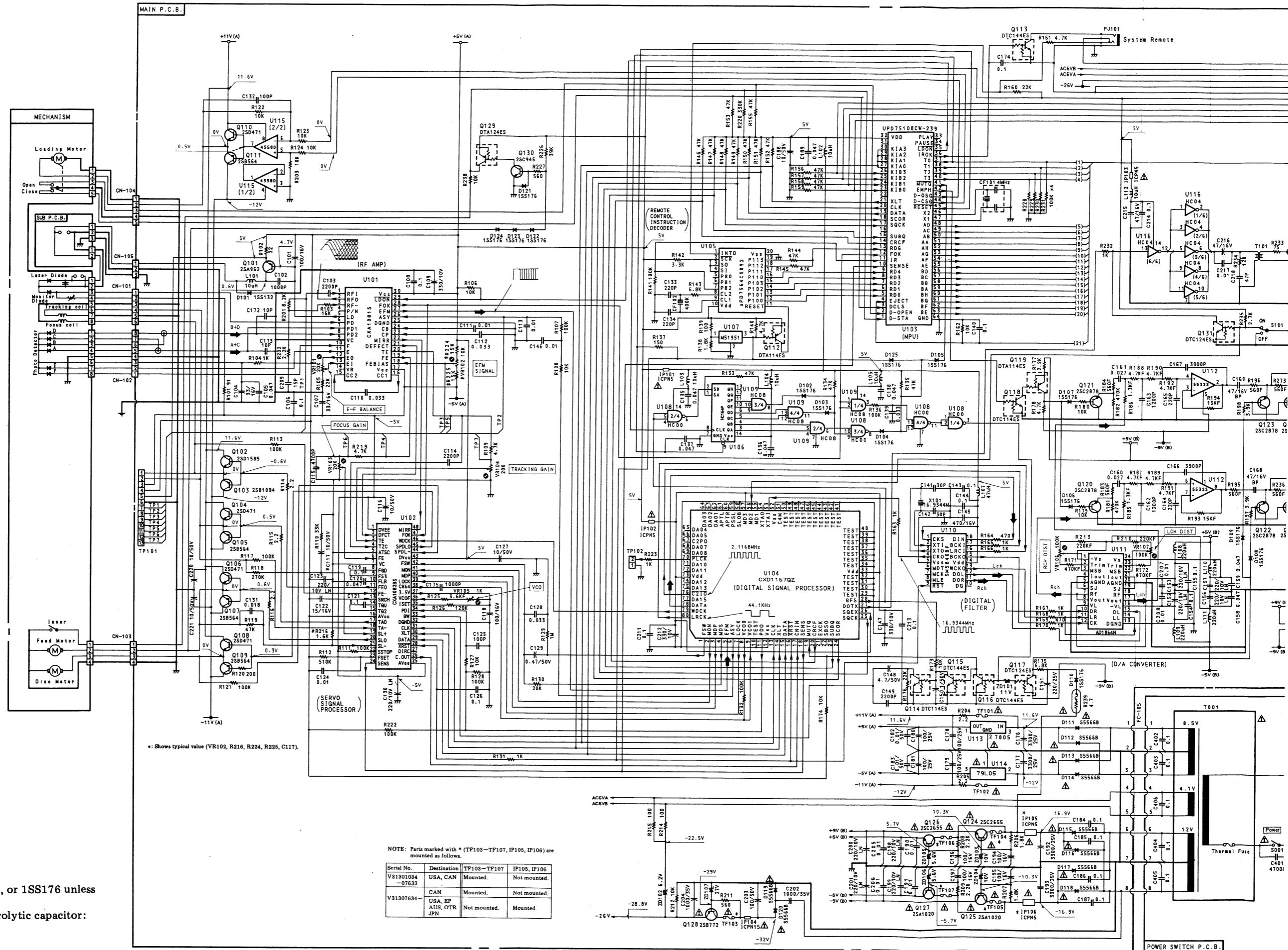
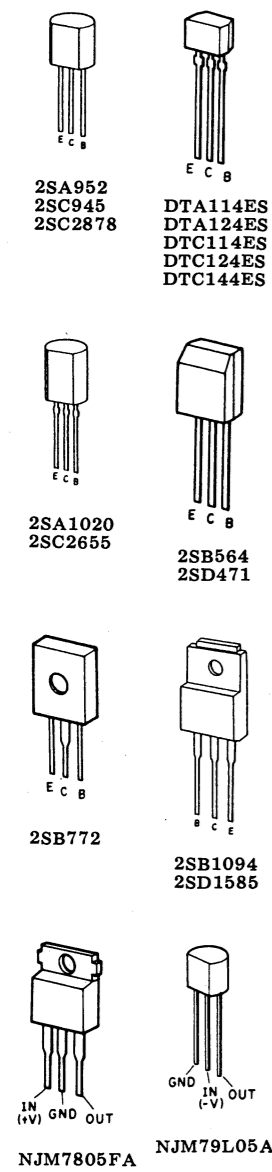

Fig. 8.1.14 Voltage Drop Detector M51951ASL

8.2. Schematic Diagram



* Shows typical value (VR102, R216, R224, R225, C117).

NOTE: Parts marked with * (TF103-TF107, IP105, IP106) are mounted as follows.

Serial No.	Destination	TF103-TF107	IP105, IP106
V31301034 -07638	USA, CAN	Mounted.	Not mounted.
V31307634	CAN	Mounted.	Not mounted.
	USA, EP	Not mounted.	Mounted.
	AUS, OTR		
	JPN		

- Notes:
- Diode is 1SS53, 1S1555, or 1SS176 unless otherwise specified.
 - Description of the electrolytic capacitor:
100/16V = 100µ 16V

Fig. 8.2

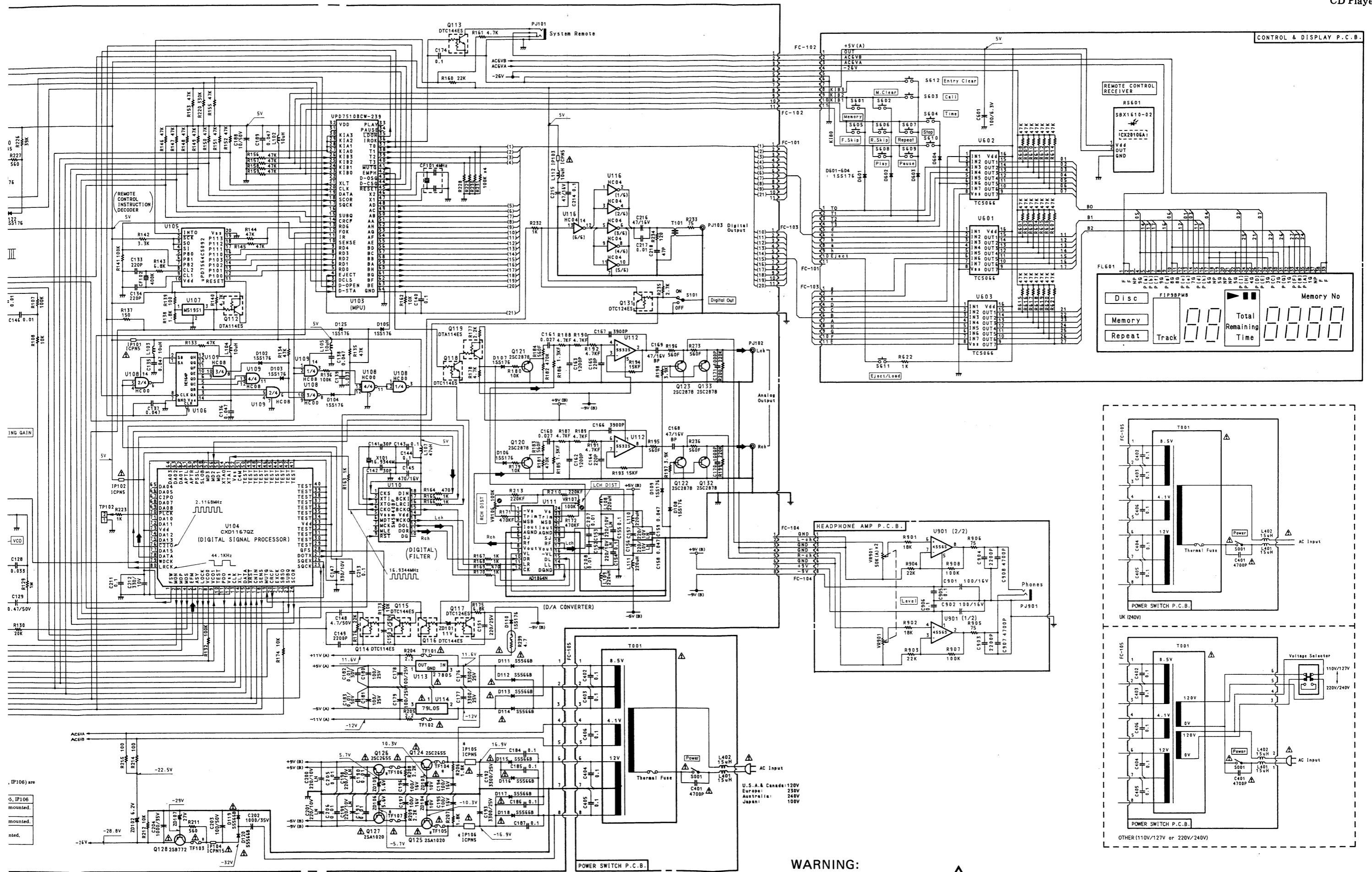

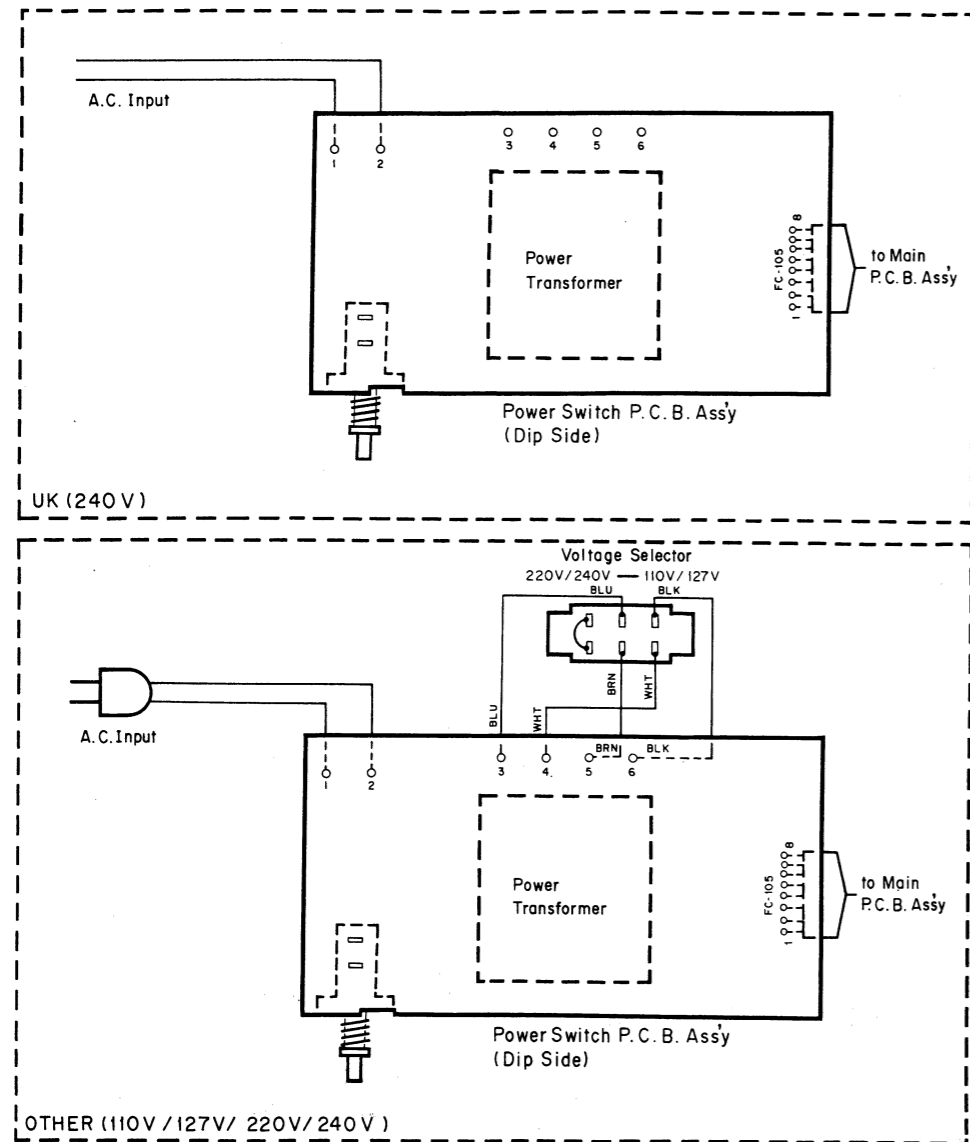

Fig. 8.2

WARNING:
 Parts marked with the symbol  have critical characteristics.
 Use **ONLY** replacement parts recommended by the manufacturer.

It is recommended that the unit be operated from a suitable DC supply or batteries during initial check-out procedures.

9. WIRING DIAGRAM



Notes: 1. Table of wire colors

BRN — Brown	BLU — Blue
RED — Red	VIO — Violet
ORN — Orange	GRY — Gray
YEL — Yellow	WHT — White
BRN — Green	BLK — Black

2. Component side view of the P.C.B. is illustrated unless otherwise specified.

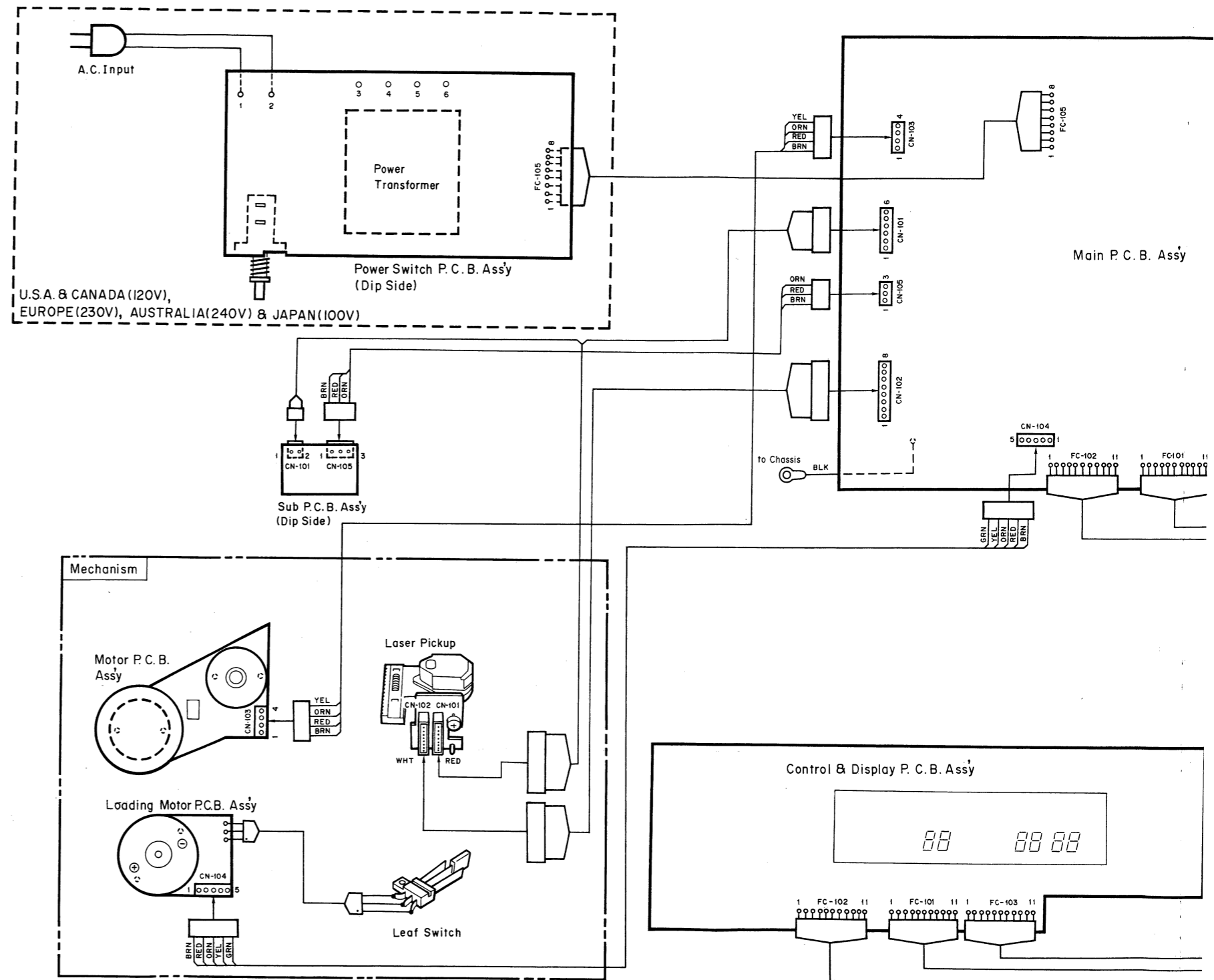

Fig. 9

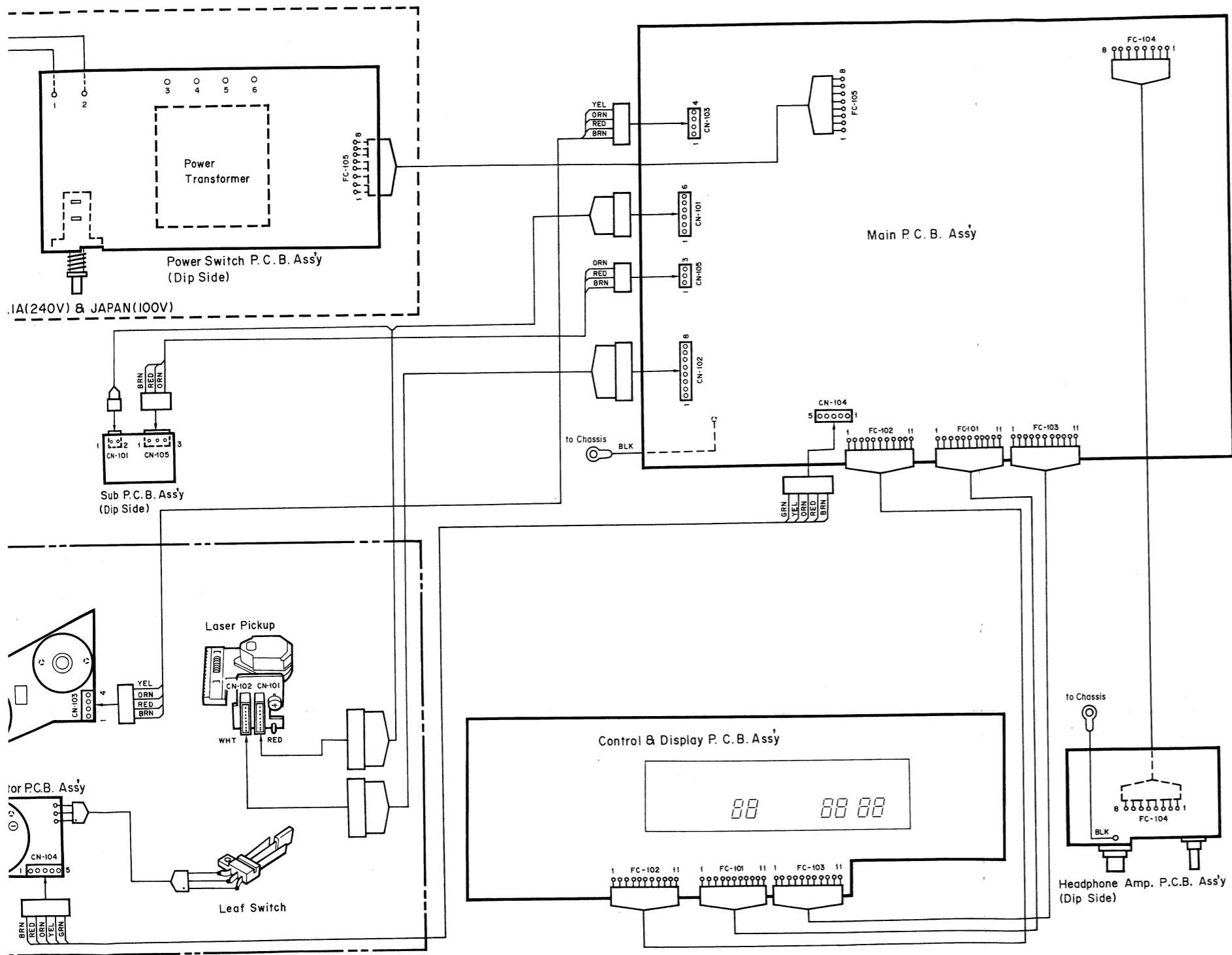

Fig. 9

10. BLOCK DIAGRAM

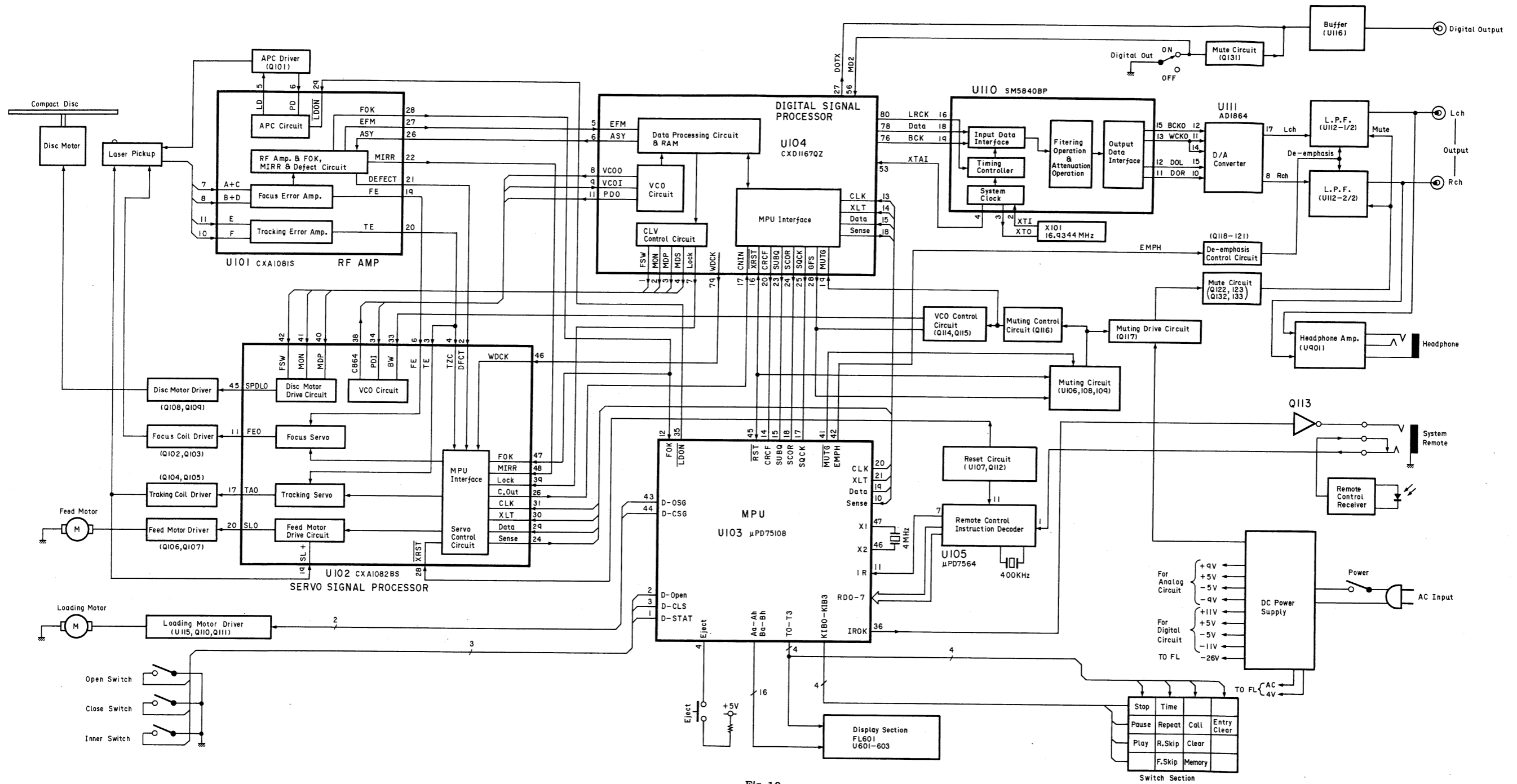

Fig. 10

11. TIMING CHART

(1) Operational Timing Chart

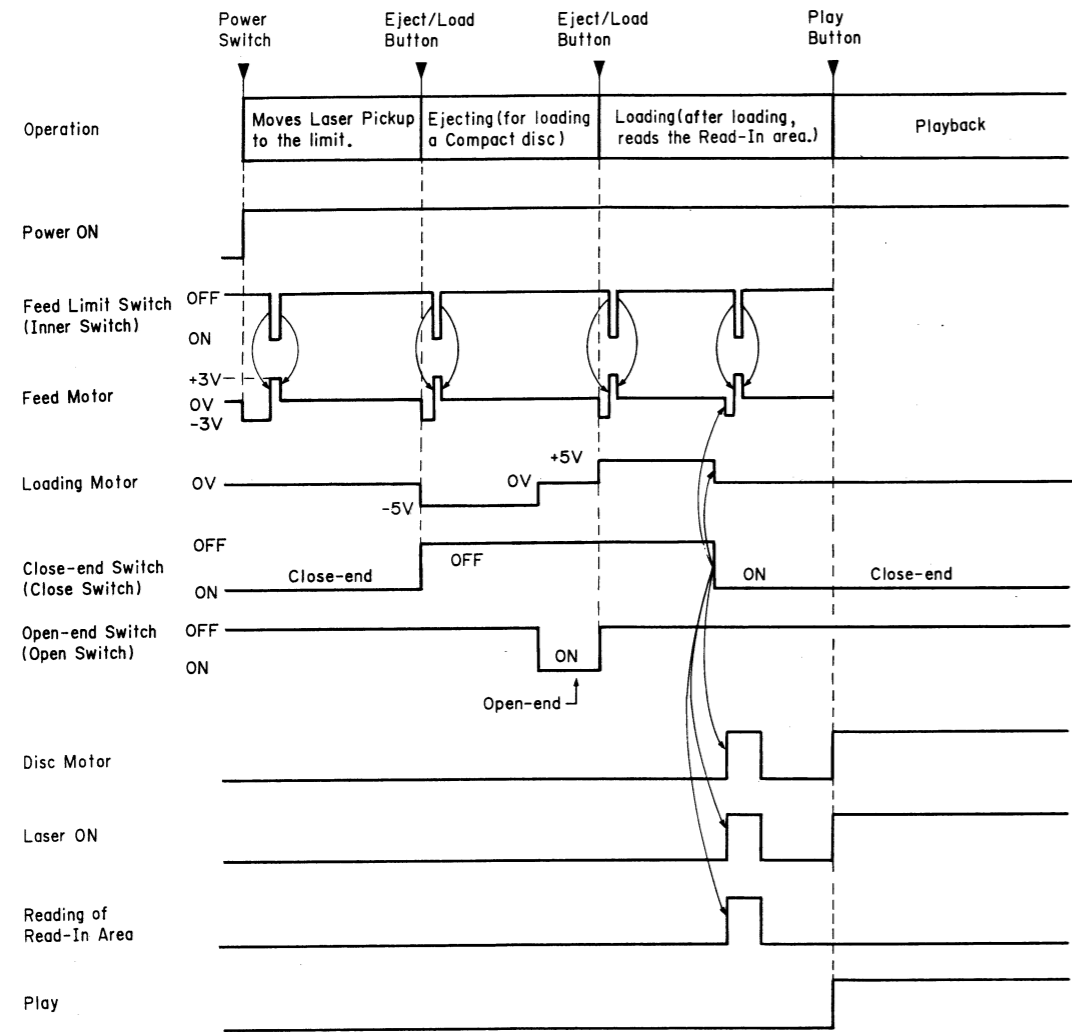

Fig. 11.1

(2) Operational Flowchart

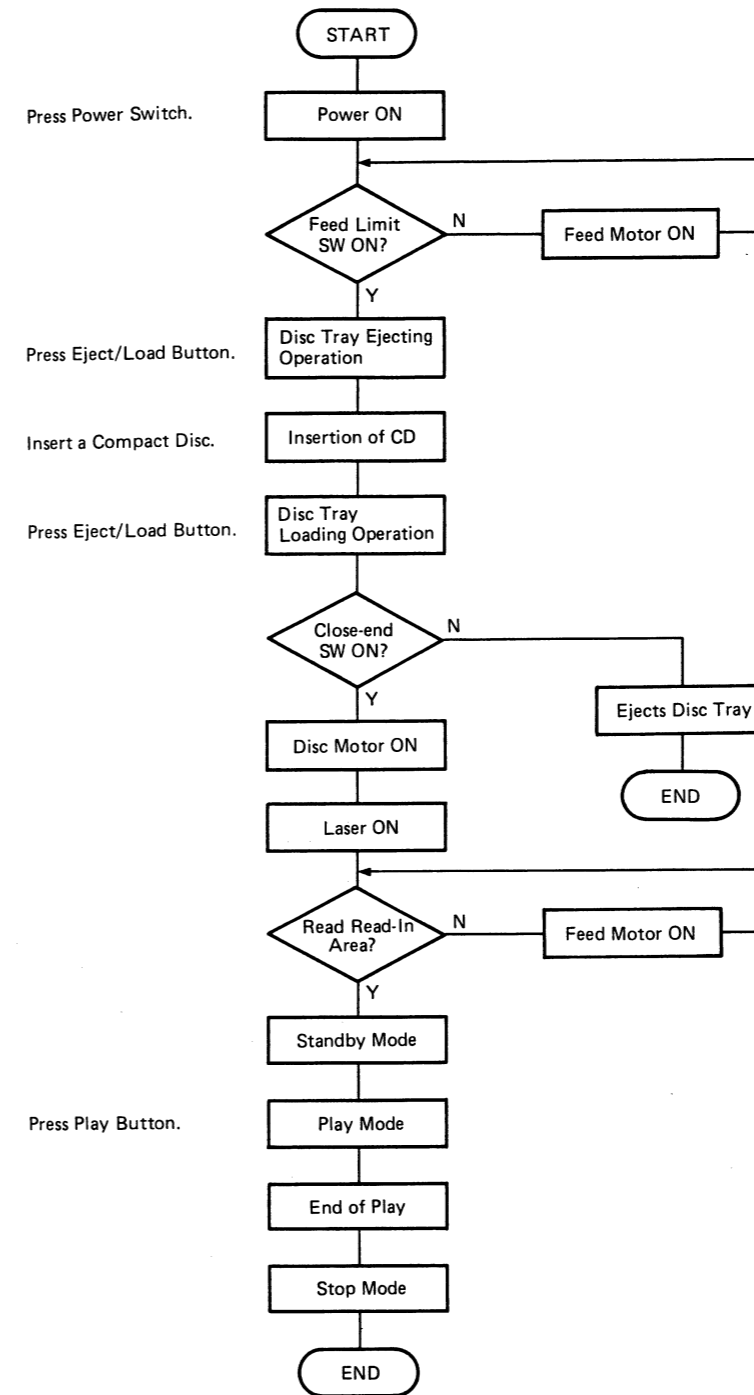

Fig. 11.2

12. SPECIFICATIONS

● Main Unit

System	Compact Disc digital audio
Signal Readout	Optical (semiconductor laser)
Error Correction	CIRC principle
Number of Channels	2 channels, stereo
D/A Converter Type	18-bit Dual D/A converters with 8-times oversampling digital filter
Sampling Frequency	44.1 kHz
Quantization	16 bit linear
Disc Rotational Velocity	Approx. 200 to 500 rpm (constant linear velocity)
Wow and Flutter	Below measurement limit
Frequency Response	5—20,000 Hz ± 0.5 , -1 dB
Signal to Noise Ratio (IHF A-WTD)	Better than 105 dB
Dynamic Range	Better than 97 dB
Total Harmonic Distortion (1 kHz)	0.0035%
Total Harmonic Distortion + Noise (1 kHz)	0.004%
Channel Separation	Better than 95 dB
Output Level/Impedance (1 kHz, 0 dB)	
Line	2.0 V/600 ohms
Headphone	60 mW into 40 ohms
Power Requirements	120, 230, 240 or 110—127/220—240V 50/60 Hz (According to country of sale)
Power Consumption	20 W max.
Dimensions*	430 (W) x 100 (H) x 320 (D) mm 16-15/16 (W) x 3-15/16 (H) x 12-5/8 (D) inches
Approximate Weight	5.0 kg, 11 lbs.

● Remote Control Unit

Principle	Infrared pulse system
Power Supply	3 VDC (1.5 Vx2)
Dimensions*	63 (W) x 18 (H) x 135 (D) mm 2-1/2 (W) x 11/16 (H) x 5-5/16 (D) inches
Approximate Weight	100 g, 3-1/2 oz (including batteries)

*: Dimensions do not include protruding parts. Height is the panel height.

●: Specifications and design are subject to change for further improvement without notice.

MC-Service