

A21



Service Manual

Nakamichi

CR-2

CR-2A

CR-2E

CR-20

2 Head Cassette Deck

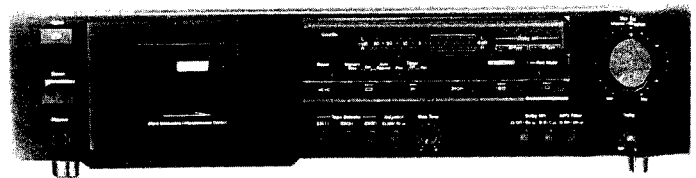

A21

CONTENTS

1.	General	1
2.	Removal Procedures	3
2. 1.	Top Cover Ass'y and Bottom Cover Ass'y	3
2. 2.	Cassette Case Cover Ass'y	3
2. 3.	Mechanism Ass'y	3
2. 4.	Pin Jack P.C.B. Ass'y and Main P.C.B. Ass'y	3
2. 5.	Front Panel	4
2. 6.	Bias Tune Volume P.C.B. Ass'y	4
2. 7.	Control P.C.B. Ass'y	4
2. 8.	Power Switch Joint	4
3.	Test Tapes and Gauges	5
4.	Mechanical Adjustments	5
4. 1.	Tape Guide Height Check for Record/Playback Head and Erase Head	5
4. 2.	Head Base Stroke Check	5
4. 3.	Record/Playback Head Azimuth Alignment and Height Check	5
4. 4.	Pressure Adjustment of Pressure Roller	6
4. 5.	Tape Travelling Check	6
4. 6.	Eject Damper Adjustment	6
4. 7.	Reel Motor Speed Adjustment in Play Mode	6
4. 8.	Tape Speed Adjustment	6
4. 9.	Lubrication	6
5.	Parts Location for Electrical Adjustment	7
6.	Electrical Adjustments	8
7.	Mechanism Ass'y and Parts List	11
7. 1.	Synthesis	11
7. 2.	Chassis Ass'y (A01)	12
7. 3.	Bottom Cover Ass'y (A02)	12
7. 4.	Mechanism Ass'y (B01)	13
7. 5.	Front Escutcheon Ass'y (B02)	14
8.	Mounting Diagrams and Parts List	15
8. 1.	Fuse P.C.B. Ass'y	15
8. 2.	Pin Jack P.C.B. Ass'y	15
8. 3.	Input Volume P.C.B. Ass'y	15
8. 4.	Output Volume P.C.B. Ass'y	16
8. 5.	Headphone P.C.B. Ass'y	16
8. 6.	Bias Tune Volume P.C.B. Ass'y	16
8. 7.	Shut-off P.C.B. Ass'y	16
8. 8.	Control P.C.B. Ass'y	16
8. 9.	Main P.C.B. Ass'y	17
9.	Schematic Diagram	19
9. 1.	IC Block Diagrams	19
9. 2.	Schematic Diagram	24
10.	Wiring Diagram	25
11.	Block Diagrams	26
11. 1.	Amplifier Section	26
11. 2.	Mechanism Control Section	27
12.	Timing Charts and Eq. Amp. Frequency Response	28
12. 1.	Timing Charts	28
12. 2.	Eq. Amp. Frequency Response	29
13.	Specifications	30

1. GENERAL

1.1. Voltage Selector

Voltage selector is installed on the rear panel for Other version of the Nakamichi CR-2.
This voltage selector can select 110, 127, 220, or 240 V at customer's disposal.

1.2. Package Ass'y and Accessory Ass'y

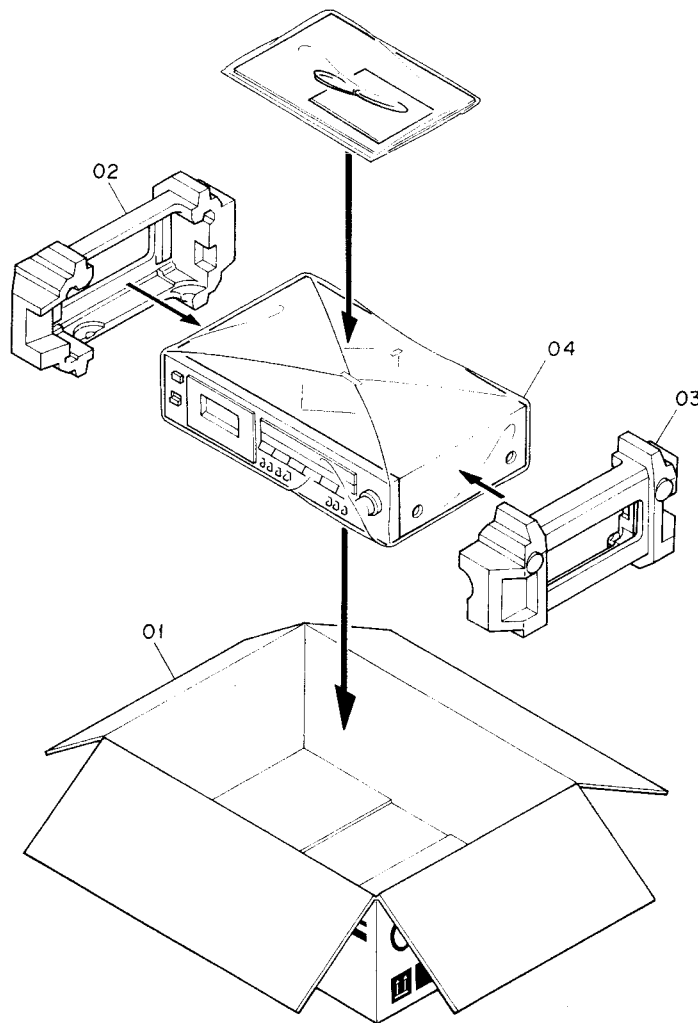

Fig. 1

Schematic Ref. No.	Part No.	Description	Q'ty	Schematic Ref. No.	Part No.	Description	Q'ty
		Package Ass'y	1			Accessory Ass'y	1
01	0F04070A	Carton Box (CR-2)	1		0D03092B	Poly-Bag	1
	0F04071A	Carton Box (CR-2A)	1		0D04449A	Important Notice (CR-2, CR-2E & CR-20)	1
	0F04072A	Carton Box (CR-2E)	1		0D04810A	Important Notice (CR-2A)	1
	0F04100A	Carton Box (CR-20)	1		0D04766A	General Catalogue (CR-2A)	1
02	0F04087C	Packing L	1		0D04780B	Owner's Manual (English/ German/French)	1
03	0F04088C	Packing R	1		0D04781B	Owner's Manual (Japanese)	1
04	0F03684A	Poly-Sheet S	1		0D04785B	Price Card (CR-20)	1
	0D04046A	Warranty Card (CR-20)	1		0D04796A	Tape Catalogue (CR-2A)	1
	0D04047A	User's Pack (CR-20)	1		0D04795A	Tape Catalogue (CR-20)	1
	0M03457A	Voltage Label 240V (CR-2 (Australia) & CR 2E (UK))	2		0D04797A	Warranty Card (CR-2A)	1
	0M05101A	Voltage Label (CR-2 (Saudi Arabia))	2		0D04812A	Tape Supplement	1
	0M05070A	Serial No. Label (CR-2A)	2		0M03844B	Power Cord Label (CR-2E (UK))	1
	0M05054A	Serial No. Label (CR-2, CR-2E & CR-20)	1		DA04121A	Pin Cord Ass'y	1
	0M05087A	Point of Sale Label (CR-20)	1				
	0M05106A	UL Label (CR-2A)	1				
	0M05105A	LA Label (CR-2A)	1				
	0M05107A	Canada Label (CR-2A)	1				
	0M05108A	UL/Canada Label (CR-2A)	1				
	0M05102A	Shipping Label Los (CR-2A)	1				
	0M05103A	Shipping Label VAN (CR-2A)	1				

2. REMOVAL PROCEDURES

2.1. Top Cover Ass'y and Bottom Cover Ass'y Refer to Fig. 2.1.

- (1) Loosen F01 and remove F02 (Top Cover Ass'y).
- (2) Loosen F03 and remove F04 (Bottom Cover Ass'y).

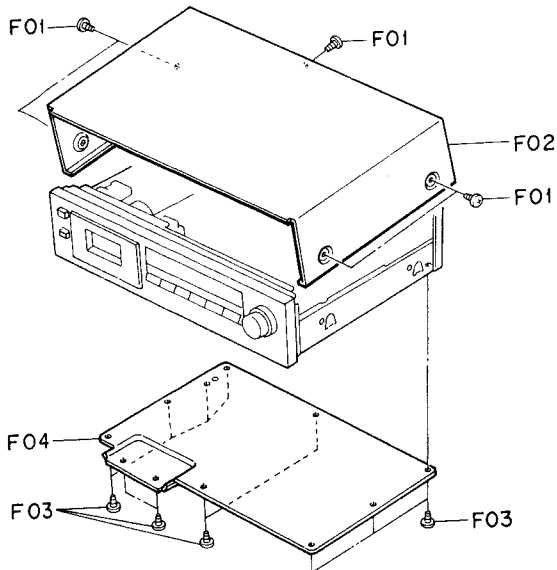

Fig. 2.1

2.2. Cassette Case Cover Ass'y Refer to Fig. 2.2.

- (1) Press F01 (Eject Button) to open F02 (Cassette Case Cover Ass'y).
- (2) Pull F02 (Cassette Case Cover Ass'y) upward.

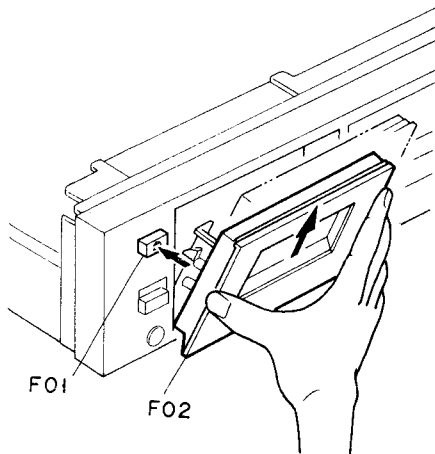

Fig. 2.2

2.3. Mechanism Ass'y Refer to Fig. 2.3.

- (1) Remove the Top Cover Ass'y and the Bottom Cover Ass'y referring to item 2.1.
- (2) Remove the Cassette Case Cover Ass'y referring to item 2.2.
- (3) Loosen F01 and F02, remove F03, and disassemble F04 (Mechanism Ass'y).

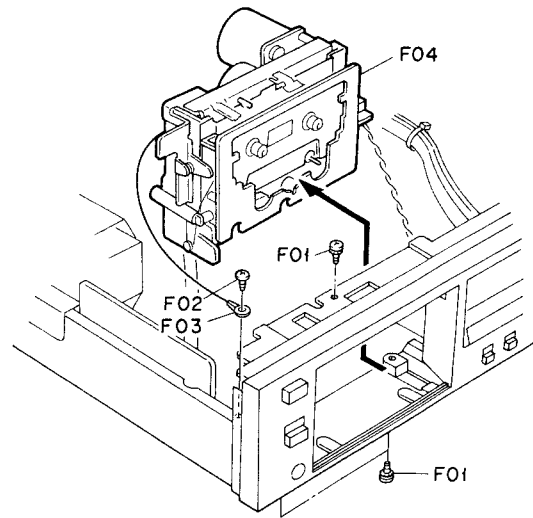

Fig. 2.3

2.4. Pin Jack P.C.B. Ass'y and Main P.C.B. Ass'y Refer to Fig. 2.4.

- (1) Remove the Top Cover Ass'y and the Bottom Cover Ass'y referring to item 2.1.
- (2) Loosen F01 and remove F02 (Pin Jack P.C.B. Ass'y).
- (3) Loosen F03 and F04, and lift F05 (Main P.C.B. Ass'y).

Note: When installing the Main P.C.B. Ass'y, to facilitate installation, place the Main P.C.B. Ass'y so that the tops of switches on the Main P.C.B. Ass'y come in contact with the ends of push buttons as shown in Fig. 2.5.

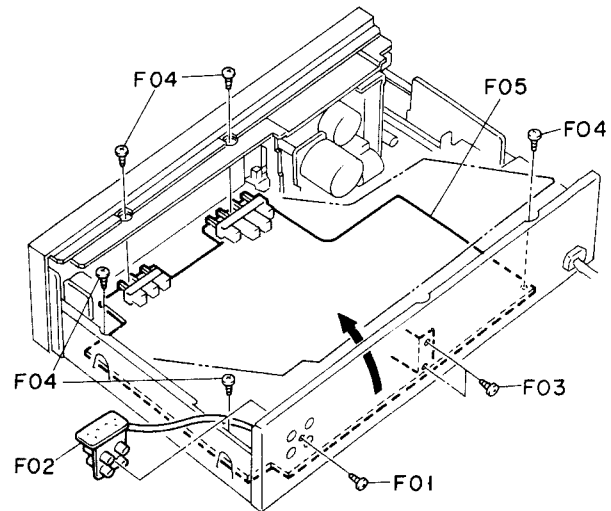

Fig. 2.4

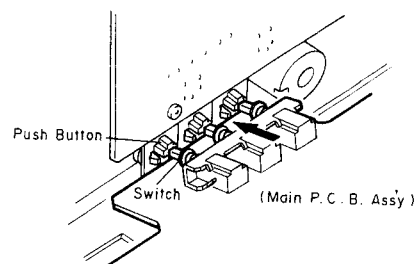

Fig. 2.5

2.5. Front Panel

Refer to Fig. 2.6.

- (1) Remove the Top Cover Ass'y and the Bottom Cover Ass'y referring to item 2.1.
- (2) Remove the Cassette Case Cover Ass'y referring to item 2.2.
- (3) Pull out F01, F02 and F03, and loosen F04 and F05.
- (4) With pushing claws by hand as shown in the figure, remove F06 (Front Panel).

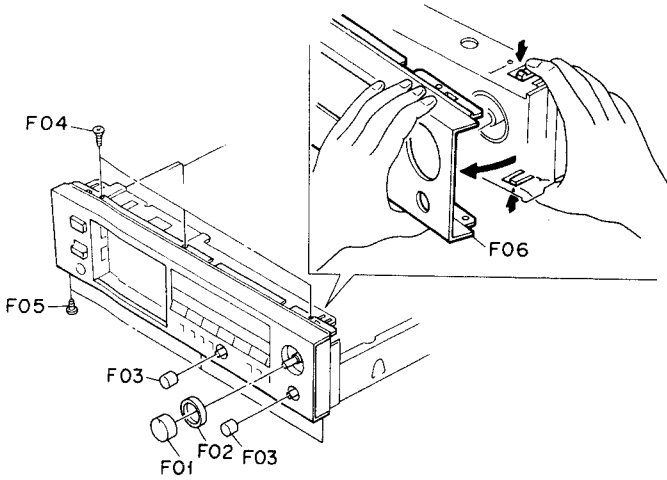

Fig. 2.6

2.6. Bias Tune Volume P.C.B. Ass'y

Refer to Fig. 2.7.

- (1) Remove the Top Cover Ass'y and the Bottom Cover Ass'y referring to item 2.1.
- (2) Remove the Main P.C.B. Ass'y referring to item 2.4.
- (3) Remove the Front Panel referring to item 2.5.
- (4) Loosen F01 and F02 with a special nut driver or with pliers, and remove F03 (Bias Tune Volume P.C.B. Ass'y).

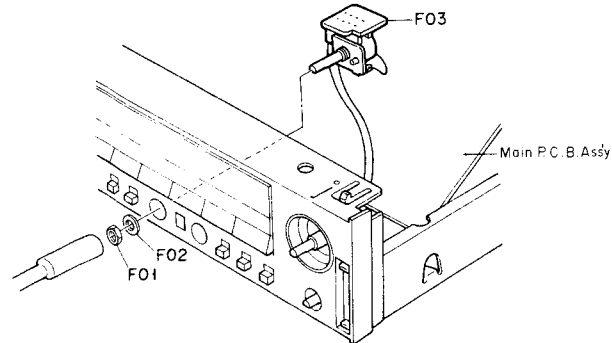

Fig. 2.7

2.7. Control P.C.B. Ass'y

Refer to Fig. 2.8.

- (1) Remove the Top Cover Ass'y and the Bottom Cover Ass'y referring to item 2.1.
- (2) Remove the Mechanism Ass'y referring to item 2.3.
- (3) Remove the Front Panel referring to item 2.5.
- (4) Loosen F01 and F02 with a special nut driver or with pliers to set F03 (Bias Tune Volume P.C.B. Ass'y) free.
- (5) With pushing F03 (Bias Tune Volume P.C.B. Ass'y) in the direction of the arrow, loosen F04, unhook F05, and remove F06 (Control P.C.B. Ass'y).

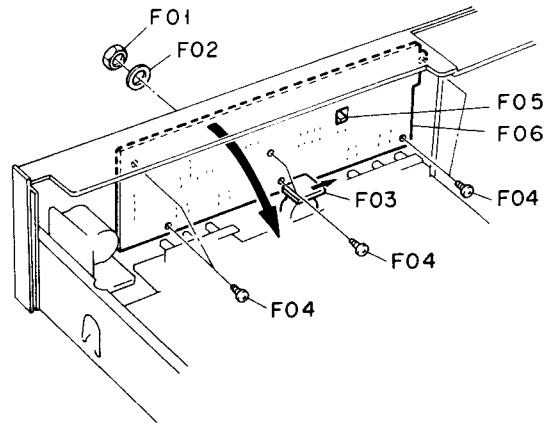

Fig. 2.8

2.8. Power Switch Joint

Refer to Fig. 2.9.

- (1) Remove the Top Cover Ass'y referring to item 2.1.
- (2) Pull F01 (Power Switch Joint) upward to remove it.

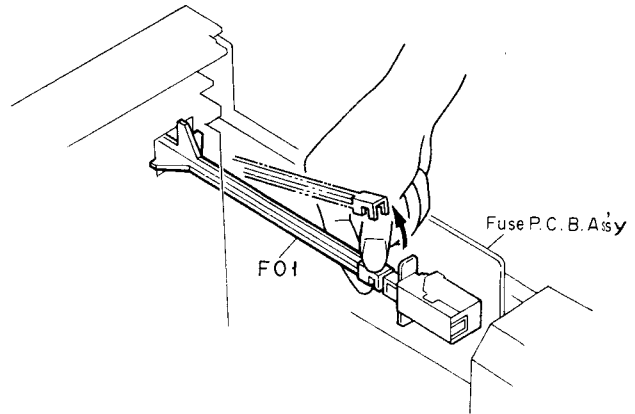

Fig. 2.9

3. TEST TAPES AND GAUGES

- (1) 400 Hz Level Tape (DA09005B)
- (2) 1 kHz Track Alignment Tape (DA09007B)
- (3) 10 kHz PB Frequency Response Tape (DA09003B)
- (4) 15 kHz PB Frequency Response Tape (DA09002B)
- (5) 20 kHz PB Frequency Response Tape (DA09001B)
- (6) 15 kHz Azimuth Tape (DA09004B)
- (7) 3 kHz Speed and Wow/Flutter Tape (DA09006C)
- (8) Tape Travelling Cassette (DA09071A)
- (9) Reference EXII Tape (DA09111A)
- (10) Reference SX Tape (DA09110A)
- (11) Reference ZX Tape (DA09109A)
- (12) Head Alignment Gauge (DA09092B)
- (13) Torque Gauge FWD (DA09082A)

4. MECHANICAL ADJUSTMENTS

4.1. Tape Guide Height Check for Record/Playback Head and Erase Head

With use of a Head Alignment Gauge (DA09092B), tape guide height check for the Record/Playback and Erase Heads shall be made, wherein a small block shall be pushed straight down to the base while in use of the Head Alignment Gauge (DA09092B). Refer to Fig. 4.1.

- (1) **Record/Playback Head Tape Guide Height**
 - (a) Load the base of the Head Alignment Gauge (DA09092B) carefully and set the cassette deck in Play mode.
 - (b) Place the small block of the Head Alignment Gauge (DA09092B) on the base.
 - (c) Slide the small block against the tape guide of the Record/Playback Head, and check to insure that the block is accepted by the tape guide.
 - (d) If not, loosen the screw and insert a shim (either 30 μm (OC80048A), 60 μm (OC80038A), or 100 μm (OC80039A)) to raise the Record/Playback Head, then tighten and apply a quantity of lock tight paint to the screw.
- (2) **Erase Head Tape Guide Height**
 - (a) Load the base of the Head Alignment Gauge (DA09092B) carefully and set the cassette deck in Play mode.
 - (b) Place the small block of the Head Alignment Gauge (DA09092B) on the base.
 - (c) Slide the small block against the tape guide of the Erase Head, and check whether the block is accepted by the tape guide.

4.2. Head Base Stroke Check

Refer to Fig. 4.2.

- (1) Load the base of the Head Alignment Gauge (DA09092B) carefully, then push the base toward the Record/Playback Head to eliminate the clearance between the reference pin and the base.
- (2) Set the cassette deck in Play mode.
- (3) Place the small block of the Head Alignment Gauge (DA09092B) on the base.
- (4) Contact the small block with the Record/Playback Head surface and the Erase Head surface, and check whether the end of the small block is located within the specified tolerance as shown in Fig. 4.2.

4.3. Record/Playback Head Azimuth Alignment and Height Check

Refer to Fig. 4.1.

- (1) Contact an AC voltmeter to the Output Jacks.
- (2) Load a 15 kHz Azimuth Tape (DA09004B) and set the cassette deck in Play mode.
- (3) Turn the Azimuth Alignment Screw until the outputs of both channels become maximum.
- (4) Load a 1 kHz Track Alignment Tape (DA09007B) and set the cassette deck in Play mode.
- (5) Check to insure that the readings of both channels on the AC voltmeter are below -25 dB. If not, replacement of the Record/Playback Head will be required.
- (6) Apply a quantity of lock tight paint to the Azimuth Alignment Screw.

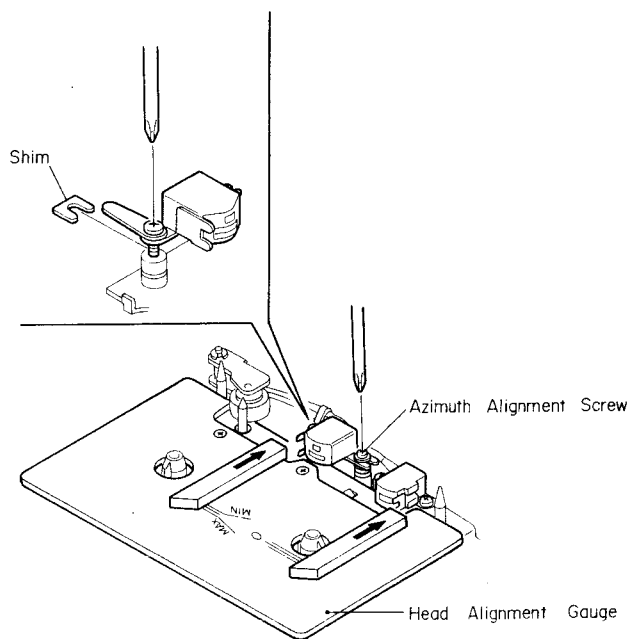

Fig. 4.1

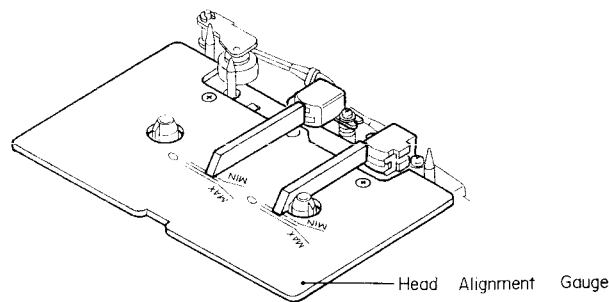

Fig. 4.2

4.4. Pressure Adjustment of Pressure Roller

Refer to Fig. 4.3.

- (1) In Play mode, measure the torque of the Pressure Roller and check whether the torque is in a range of 320 ± 50 g-cm.
- (2) If torque is out of the range, correct it by changing the installation point of the Pressure Roller Spring.

4.5. Tape Travelling Check

Load a Tape Travelling Cassette (DA09071A) and set the cassette deck in Play mode to check the followings:

- (1) After more than 2 seconds, the fluctuation of the tape travelling on the Record/Playback Head is small.
- (2) Tape is in contact with the head sufficiently.
- (3) Tape waving is small on the heads and pressure roller.

4.6. Eject Damper Adjustment

Refer to Fig. 4.4. Load a cassette tape, and with opening the Cassette Case by pressing the Eject button and closing it by hand, adjust the speed of damper action by the Damper Adjustment Screw.

CCW: Damper moves fast.

CW: Damper moves slowly.

4.7. Reel Motor Speed Adjustment in Play Mode

- (1) Load a Torque Gauge FWD (DA09082A) and set the cassette deck in Play mode.
- (2) After 5 to 10 seconds, adjust VR601 on the Main P.C.B. Ass'y to obtain exactly 45 g-cm on the torque gauge.

4.8. Tape Speed Adjustment

Refer to Fig. 4.5.

- (1) Connect a frequency counter to the Output Jacks.
- (2) Load a 3 kHz Speed and Wow/Flutter Tape (DA09006C) and play it back.
- (3) Adjust the Tape Speed Adjustment Volume incorporated in the Capstan Motor to obtain 3,000 Hz on the frequency counter.

CCW: Motor drives slowly.

CW: Motor drives fast.

4.9. Lubrication

The tape transport is of a lubrication-free type mechanism. When the following parts are replaced, apply the specified lubricant.

- (1) Molykote (R) Grease (X5-6020)
Cam Motor Pulley
Thrust portion on the Capstan Shaft
- (2) FLOIL GB-TS-1
Washer between Reel Hub Ass'y and Back Tension Spring
- (3) Diamond Oil (EP-56)
Reel Hub Shaft
- (4) Anderol 456
Capstan Shaft

Note: We suggest that you use the above specified lubricant or equivalent type.

The company dealing in the above lubricant is as follows:

- (a) Molykote (R) Grease (X5-6020)
Dowcorning Co., Ltd., 1-15-1 Nishishinbashi, Minato-ku, Tokyo, Japan
- (b) FLOIL GB-TS-1
Kanto Chemicals Co., Ltd., 2-7 Kanda Sakuma-cho, Chiyoda-ku, Tokyo, Japan
- (c) Diamond Oil (EP-56)
Mitsubishi Oil Co., Ltd., 1-2-4 Toranomom, Minato-ku, Tokyo, Japan
- (d) Anderol 456
Toyo Kokusai Oil Co., Ltd., 3-3-5 Hatchobori, Chuo-ku, Tokyo, Japan

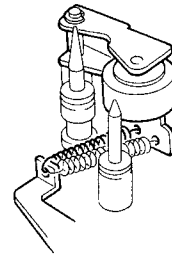

Fig. 4.3

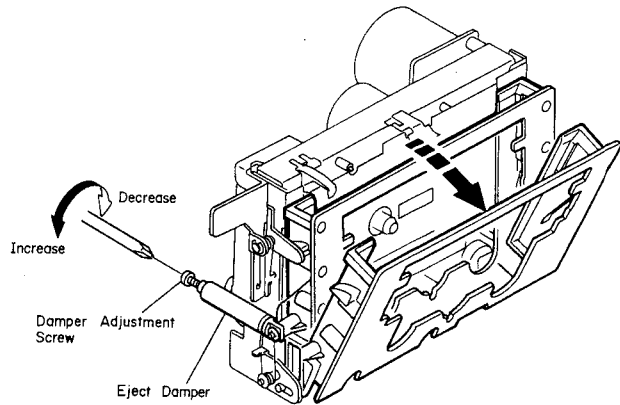

Fig. 4.4

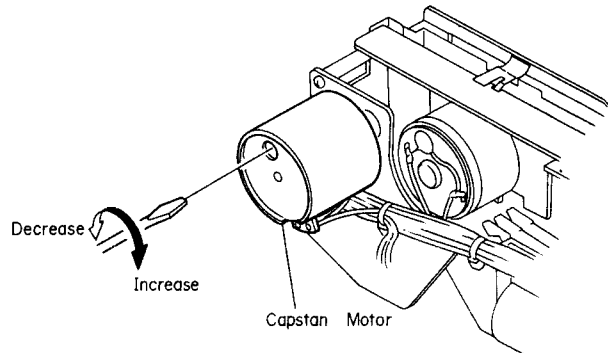

Fig. 4.5

5. PARTS LOCATION FOR ELECTRICAL ADJUSTMENT

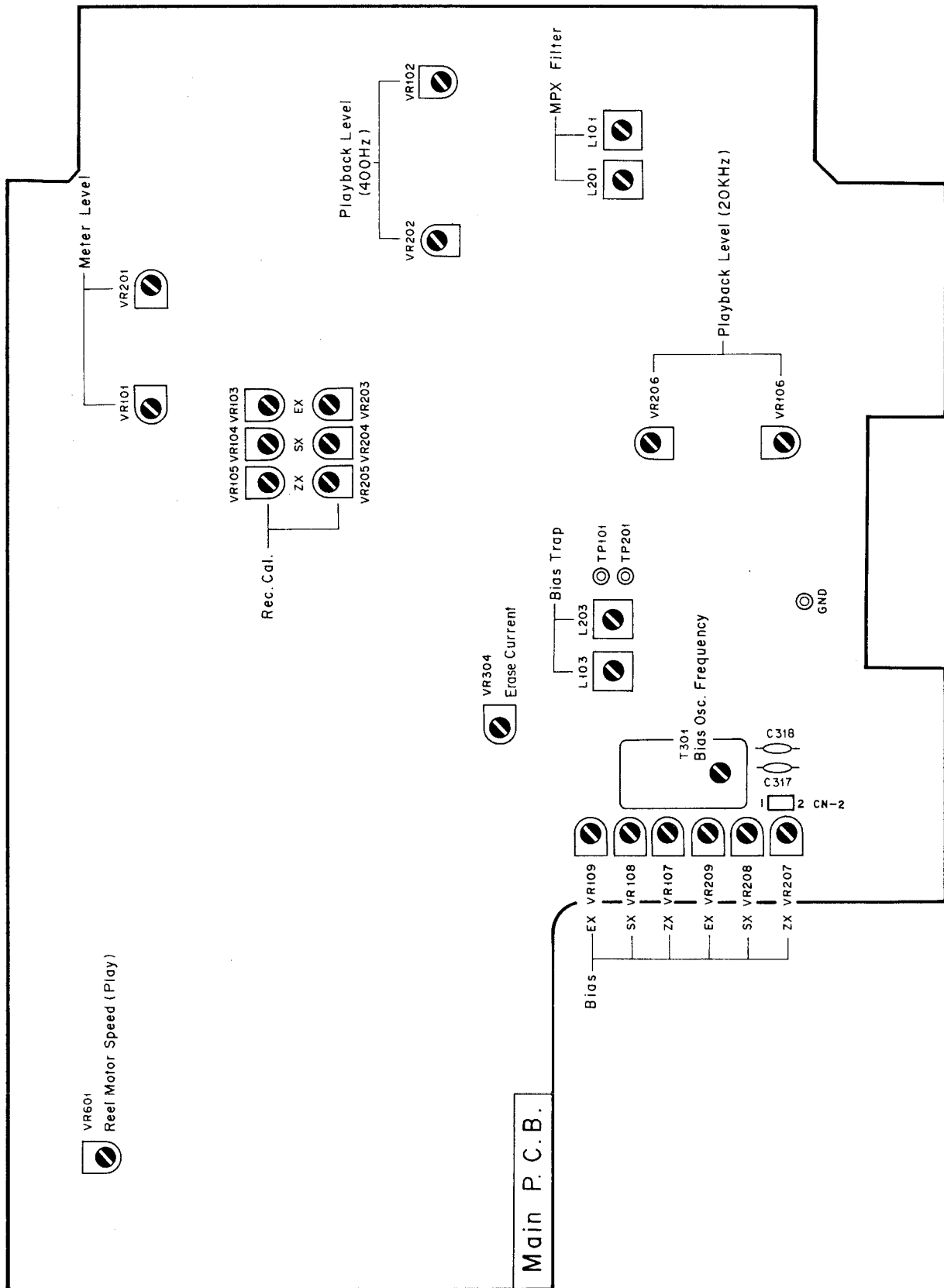
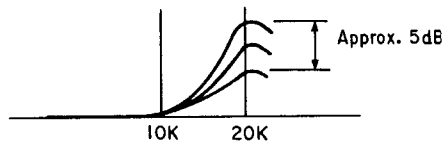

Fig. 5

6. ELECTRICAL ADJUSTMENTS

STEP	ITEM	SIGNAL SOURCE	OUTPUT CONNECTION	MODE	ADJUSTMENT	REMARKS
1	Preliminary Step			Output Level - Max. Balance - Center Bias Tune - Center Eq. - 70 μ s Tape - ZX MPX Filter - OFF Dolby NR - OFF		Set the CR-2/2A/2E/20 as shown in MODE.
2	Reel Motor Speed Adjustment (Play)	Torque Gauge FWD (DA09082A)		Playback	Main VR601	1. Play back a Torque Gauge FWD, and after 5 to 10 seconds, adjust VR601 to obtain 44 ± 1 g-cm on the Torque Gauge at 25 degrees (45 ± 1 g-cm at 20 degrees). 2. Check that the deviation of the torque value is within ± 10 g-cm of the center value. Note: Torque adjustment must be done after leaving the CR-2/2A/2E/20 for one hour with the power switch turned OFF.
3	Tape Speed Adjustment	3 kHz Speed and Wow/Flutter Tape (DA09006C)	Frequency Counter to Output Jacks	Playback Eq. - 70 μ s	Tape Speed Adj. Volume (Capstan Motor)	Adjust the volume incorporated in the capstan motor to obtain 3 kHz ± 15 Hz on the frequency counter.
4	Meter Level Calibration	400 Hz to Input Jacks	AC Voltmeter to Output Jacks	Record, Pause	Main P.C.B. VR101 VR201	1. Feed in 400 Hz and adjust the Input Level control to obtain 500 mV -1.2 dB on the AC voltmeter. 2. Adjust VR101 (VR201) so that the 0 dB segment of the level meter starts illuminating.
5	MPX Filter Adjustment	19 kHz ± 100 Hz to Input Jacks	AC Voltmeter to Output Jacks	Record, Pause MPX - OFF/ON	Main P.C.B. L101 L201	1. Adjust the Input Level control to obtain 500 mV (0 dB) on the AC voltmeter. 2. Set the MPX Filter switch to ON and adjust L101 (L201) to obtain minimum reading on the AC voltmeter (minimum reading will be less than -30 dB).
6	Record/Playback Head Azimuth Alignment	15 kHz Azimuth Tape (DA09004B)	AC Voltmeter to Output Jacks	Playback Eq. - 70 μ s Dolby NR - OFF MPX - OFF	Record/Playback Head Azimuth Alignment Screw	Adjust the Record/Playback Head Azimuth Alignment Screw to obtain maximum readings for both channels on the AC voltmeter.
7	Playback Level Calibration	400 Hz Level Tape (DA09005B)	AC Voltmeter to Output Jacks	Same as above	Main P.C.B. VR102 VR202	Adjust VR102 (VR202) to obtain 500 mV on the AC voltmeter.

STEP	ITEM	SIGNAL SOURCE	OUTPUT CONNECTION	MODE	ADJUSTMENT	REMARKS
8	Playback Frequency Response Adjustment	400 Hz Level Tape (DA09005B) 10 kHz PB Frequency Response Tape (DA09003B) 15 kHz PB Frequency Response Tape (DA09002B) 20 kHz PB Frequency Response Tape (DA09001B)	AC Voltmeter to Output Jacks	Playback Eq. - 70 μ s Dolby NR - OFF MPX - OFF	Main P.C.B. VR106 VR206	<p>1. Load a 400 Hz level tape, play it back, and read the playback level.</p> <p>2. Load 10 kHz, 15 kHz and 20 kHz PB frequency response tapes and play them back. Adjust the record/playback head azimuth to obtain maximum readings for both channels on the AC voltmeter with each tape. Check that the playback levels are as follows with respect to the level for 400 Hz level tape.</p> <p>10 kHz: -20 dB -2 to +2 dB 15 kHz: -20 dB -2 to +3 dB 20 kHz: -20 dB -2 to +4 dB</p> <p>If the level at 20 kHz is out of the range, adjust VR106 (VR206) to obtain satisfactory results. VR106 (VR206) compensates the playback frequency response at 20 kHz as shown below:</p>  <p>3. Conduct step 6 "Record/Playback Head Azimuth Alignment".</p>
9	Bias Oscillation Frequency and Erase Current Adjustment	None	Frequency Counter between terminals 1 and 2 of CN2 on Main P.C.B. and AC Voltmeter across the additional 0.1 ohm resistor	Record, Pause Eq. - 70 μ s Tape ZX Dolby NR - OFF MPX - OFF	Main P.C.B. T301 C317 C318 VR304	<p>1. Connect an additional 0.1 ohm resistor in series to the Erase Head and connect the AC voltmeter across it.</p> <p>2. Adjust T301 to obtain 105 kHz \pm1 kHz on the frequency counter. If bias oscillation frequency is above 106 kHz, short-circuit C317 and C318, and re-adjust T301 again.</p> <p>3. Adjust VR304 to obtain 17.5 mV (175 mA) on the AC voltmeter. (16.5 \pm 1 mV (165 \pm 10 mA will be accepted.)</p> <p>4. After completion of the erase current adjustment, re-check the bias oscillation frequency.</p> <p>5. Remove the additional 0.1 ohm resistor.</p>
10	Bias Trap Adjustment (Record Amp.)	None (remove input signals)	AC Voltmeter to TP101, TP201 on Main P.C.B.	Same as above	Main P.C.B. L103 L203	Adjust L103 (L203) to obtain minimum reading on the AC voltmeter.

STEP	ITEM	SIGNAL SOURCE	OUTPUT CONNECTION	MODE	ADJUSTMENT	REMARKS
11	Record Level Calibration and Recording Bias Current Adjustment	400 Hz (0 dB) and 18 kHz (-20 dB) to Input Jacks	AC Voltmeter and Distortion Meter to Output Jacks	Record and Playback Tape - ZX/SX/EX Eq. - 70 μ s (ZX/SX) 120 μ s (EX) Dolby NR - OFF/C MPX - OFF	Main P.C.B. (Level) ZX: VR105 VR205 SX: VR104 VR204 EX: VR103 VR203 (Bias) ZX: VR107 VR207 SX: VR108 VR208 EX: VR109 VR209	Adjustment should be made in the order of ZX, SX and EX. 1. Set the cassette deck in Record/Pause mode. 2. Feed in 400 Hz and adjust the Input Level control to obtain 500 mV (0 dB) on the AC voltmeter. 3. Load a reference ZX tape, reference SX tape and reference EXII tape. 4. Set the Dolby NR switch to OFF. 5. Feed in 400 Hz (0 dB) and record, rewind and play it back. Adjust VR105 (VR205) for ZX tape, VR104 (VR204) for SX Tape and VR103 (VR203) for EXII tape so that the played back output levels are 500 mV (0 dB) on the AC voltmeter. 6. Set the Dolby NR switch to C. 7. Feed in 18 kHz (-20 dB) and record, rewind and play it back. Adjust VR107 (VR207) for ZX tape, VR108 (VR208) for SX tape and VR109 (VR209) for EXII tape so that the played back output levels are 50 mV (-20 dB) on the AC voltmeter. 8. Repeat above 4 to 8 two or three times. 9. Set the Dolby NR switch to OFF. 10. Feed in 400 Hz (0 dB) and record, rewind and play it back. Check to insure whether the total harmonic distortion is less than 1.0% for ZX, SX and EXII tapes. If the total harmonic distortion exceeds the specified value, re-adjust VR106 (VR206) in Step 8 "Playback Frequency Response Adjustment", and repeat above steps till satisfactory results are obtained.

7. MECHANISM ASS'Y AND PARTS LIST

7.1. Synthesis

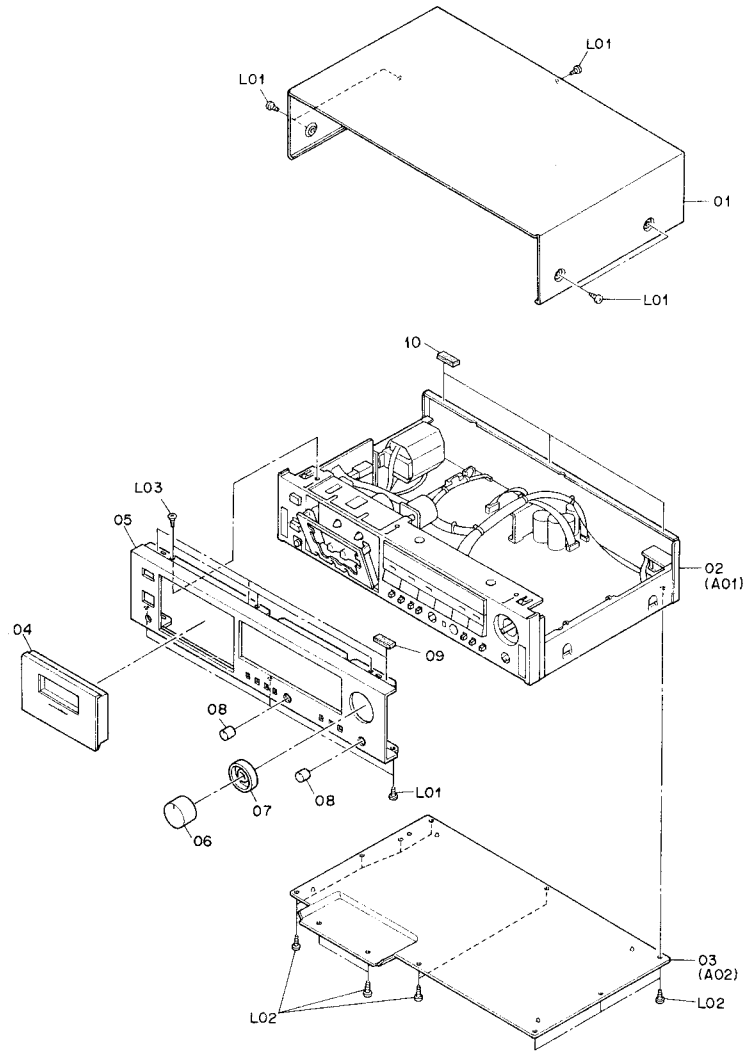

Fig. 7.1

Schematic Ref. No.	Part No.	Description	Q'ty	Schematic Ref. No.	Part No.	Description	Q'ty
7.1. Synthesis				08	HA05339A	Bias Volume Knob Ass'y	2
				09	OJ05453A	Top Cover Cushion	3
				10	OJ05407A	Top Cover Sheet	3
				L01	0E03433A	BT3x6 @ Binding Projected (Black Chromate)	8
01	OH05111A	Top Cover	1	L02	0E00868A	BT3x8 @ Binding	11
02	JA04308A	Chassis Ass'y (CR-2 (Australia))	1	L03	0E03054A	BT3x8 @ Countersunk	3
	JA04307A	Chassis Ass'y (CR-2 (Other))	1	—	0M03797A	Voltage Seal 240V (CR-2E (UK))	1
	JA04310A	Chassis Ass'y (CR-2 (Saudi Arabia))	1	—	0M03844B	Power Cord Label (CR-2E (UK))	1
	JA04311A	Chassis Ass'y (CR-2A (U.S.A.))	1	—	0M05148A	Production Date Seal (CR-2A)	1
	JA04305A	Chassis Ass'y (CR-2A (Canada))	1	—	0M04381A	EP Approval Label (CR-2E (Europe))	1
	JA04309A	Chassis Ass'y (CR-2E (Europe))	1	—	0M04732A	Voltage Label 120V (CR-2A (Canada))	1
	JA04304A	Chassis Ass'y (CR-2E (UK))	1	—	0M04811A	Voltage Caution Sheet (CR-2 (Other & Saudi Arabia))	1
	JA04306A	Chassis Ass'y (CR-20 (Japan))	1	—	0M05065A	Passed Label	1
03	JA04319A	Bottom Cover Ass'y (CR-2 & CR-2E)	1	—	0M05067A	CSA Approval Label (CR-2A (Canada))	1
	JA04329A	Bottom Cover Ass'y (CR-2A)	1	—	0M05068A	LA Label (CR-2A (U.S.A.))	1
	JA04340A	Bottom Cover Ass'y (CR-20)	1	—	0M05070A	Serial No. Seal (CR-2A)	1
04	HA05313A	Cassette Case Cover Ass'y	1	—	0M05114A	Amp. Number Seal	1
05	OH05134B	Front Panel (CR-2)	1	—	0M05111A	F. Mark Approval Seal (CR-2E (Europe))	1
	OH05132B	Front Panel (CR-2A)	1	—	MA01001A	F. Code Label Ass'y (CR-2, CR-2E & CR-20)	1
	OH05133B	Front Panel (CR-2E)	1				
	OH05135B	Front Panel (CR-20)	1				
06	HA05340A	Rec. Volume Knob Ass'y	1				
07	HA05338A	Rec. Balance Knob Ass'y	1				

Schematic Ref. No.	Part No.	Description	Qty
7.2. Chassis Ass'y (A01)			
A01	JA04308A	Chassis Ass'y (CR-2 (Australia))	1
	JA04307A	Chassis Ass'y (CR-2 (Other))	1
	JA04310A	Chassis Ass'y (CR-2 (Saudi Arabia))	1
	JA04311A	Chassis Ass'y (CR-2A (U.S.A.))	1
	JA04305A	Chassis Ass'y (CR 2A (Canada))	1
	JA04309A	Chassis Ass'y (CR-2E (Europe))	1
	JA04304A	Chassis Ass'y (CR-2E (UK))	1
	JA04306A	Chassis Ass'y (CR-20 (Japan))	1
		Serial No.: A32501001 -	
01	OJ05427A	Mount Plate	1
02	HA05308A	Front Escutcheon Ass'y	1
03	BA06969A	Headphone P.C.B. Ass'y	1
04	BA06968A	Bias Tune Volume P.C.B. Ass'y	1
05	OH05095A	Slide Button	2
06	BA06961A	Control P.C.B. Ass'y	1
07	BA06967A	Output Volume P.C.B. Ass'y	1
08	BA06966A	Input Volume P.C.B. Ass'y	1
09	OH05165A	Cover Plate	1
10	OB12580A	LED P Green SLF-725D	1
11	CA08886A	Mechanism Ass'y	1
12	OB83255A	GND Wire Ass'y	1
13	OB83132A	2P Connector	1
14	OJ05402A	Power Switch Joint	1
15	BA06964A	Fuse P.C.B. Ass'y (CR-2 & CR-2E)	1
	BA06963A	Fuse P.C.B. Ass'y (CR-2A)	1
	BA06965A	Fuse P.C.B. Ass'y (CR-20)	1
16	OJ05417C	Transformer Holder	1
17	OB50100A	Power Transformer (CR-2 (Australia) & CR-2E)	1
	OB50101A	Power Transformer (CR-2 (Other & Saudi Arabia))	1
	OB50099A	Power Transformer (CR-2A)	1
	OB50102A	Power Transformer (CR-20)	1
18	OJ05392A	Side Chassis L	1
19	BA06947A	Main P.C.B. Ass'y	1
20	OJ05451A	P.C.B. Cushion	1
21	OJ05394A	P.C.B. Holder Front	2
22	OB05241A	Power Code (CR-2 (Australia))	1
	OB08533A	Power Code (CR-2 (Other & Saudi Arabia))	1
	OB08504A	Power Code (CR-2A)	1
	OB08093U	Power Code (CR-2E (Europe))	1
	OB08348A	Power Code (CR 2E (UK))	1
	OB08219B	Power Code (CR-20)	1
23	OB90280A	Cord Bushing (CR-2 (Australia), CR-2A & CR-2E)	1
	OB90283A	Cord Bushing (CR-2 (Other & Saudi Arabia) & CR-20)	1
24	BA06970A	Pin Jack P.C.B. Ass'y	1
25	OJ05395A	P.C.B. Holder Rear	1
26	OH05146B	Rear Panel (CR-2 (Australia))	1
	OH05148B	Rear Panel (CR-2 (Other & Saudi Arabia))	1
	OH05144B	Rear Panel (CR-2A)	1
	OH05145B	Rear Panel (CR-2E)	1
	OH05147B	Rear Panel (CR-20)	1
27	OJ05393A	Side Chassis R	1
28	OB08515A	Insu-Lock	18
29	OB81771A	Voltage Selector (CR-2 (Other & Saudi Arabia))	1
30	OB60503A	Voltage Selector P.C.B. (CR-2 (Other & Saudi Arabia))	1
L01	OE00868A	BT3x8 @ Binding	10
L02	OE03212A	BT2.6x6 @ Binding with Toothed Lock Washer	3
L03	OE03433A	BT3x6 @ Binding (Black Chromate)	6
L04	OE00857A	BT3x6 @ Binding	2
L05	OE00921A	BT3x8 @ Binding (Black Chromate)	1
L06	OE00985A	M3x6 @ Binding (Black Chromate) (CR-2 (Australia), CR-2A, CR-2E & CR-20)	2
	OE00985A	M3x6 @ Binding (Black Chromate) (CR-2 (Other & Saudi Arabia))	3
L07	OJ05422A	Hole Plug	2
L08	OE03432A	BT3x6 @ Tapping (Black Chromate)	7
L09	OE03438A	ST4x6 @ Binding	2
L10	OE00859A	BT2.6x6 @ Binding	1
L11	OE03437A	FT2.5x3.5 @Pan (Black Chromate)	2
L12	OE03375A	Nut Hex. M9	1
L13	OE03376A	Washer 9mm	1
L14	OE03382A	Nut Hex. M7	2
L15	OE03383A	Washer 7mm	2
L16	OF00846A	BT3x8 @ Pan	2
-	OM05089A	Fuse Caution Label (CR-2A)	1

7.2. Chassis Ass'y (A01)

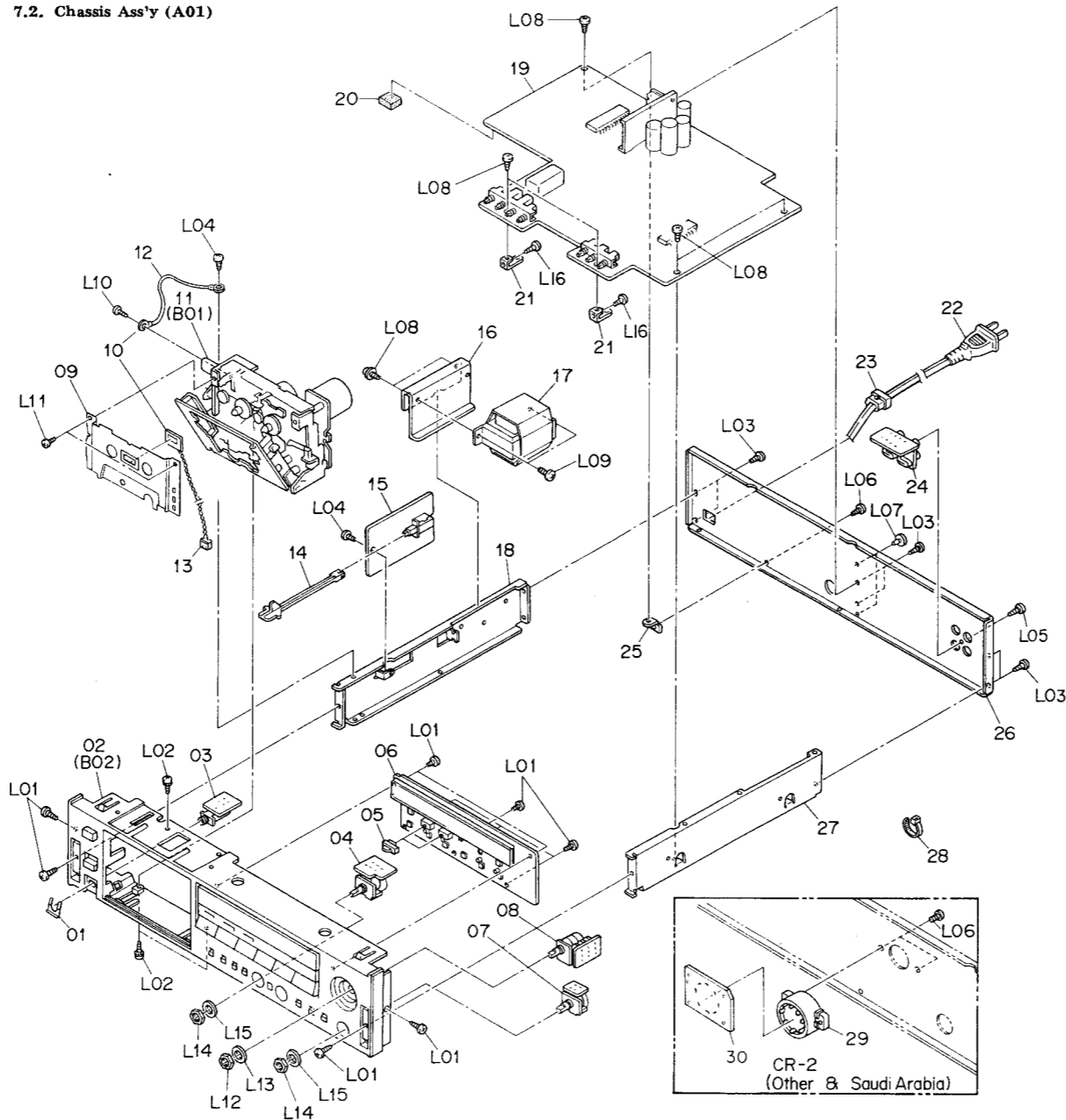

Fig. 7.2

7.3. Bottom Cover Ass'y (A02)

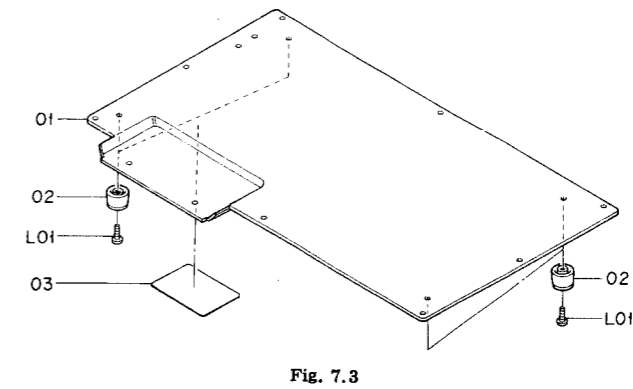

Fig. 7.3

Schematic Ref. No.	Part No.	Description	Qty
7.3. Bottom Cover Ass'y			
A02	JA04319A	Bottom Cover Ass'y (CR-2 & CR-2E)	1
	JA04329A	Bottom Cover Ass'y (CR-2A)	1
	JA04340A	Bottom Cover Ass'y (CR-20)	1
		Serial No.: A32501001 -	
01	OJ05401A	Bottom Cover	1
02	OJ05420A	Leg N (CR-2, CR-2A & CR-2E)	4
	HA05357A	Leg Ass'y (CR-20)	4
03	OM04377B	Caution Label (CR-2A)	1
L01	OE00888A	BT3x12 @ Binding	4
-	OJ05461A	Leg Felt N (CR-2, CR-2A & CR-2E)	4

7.4. Mechanism Ass'y (B01)

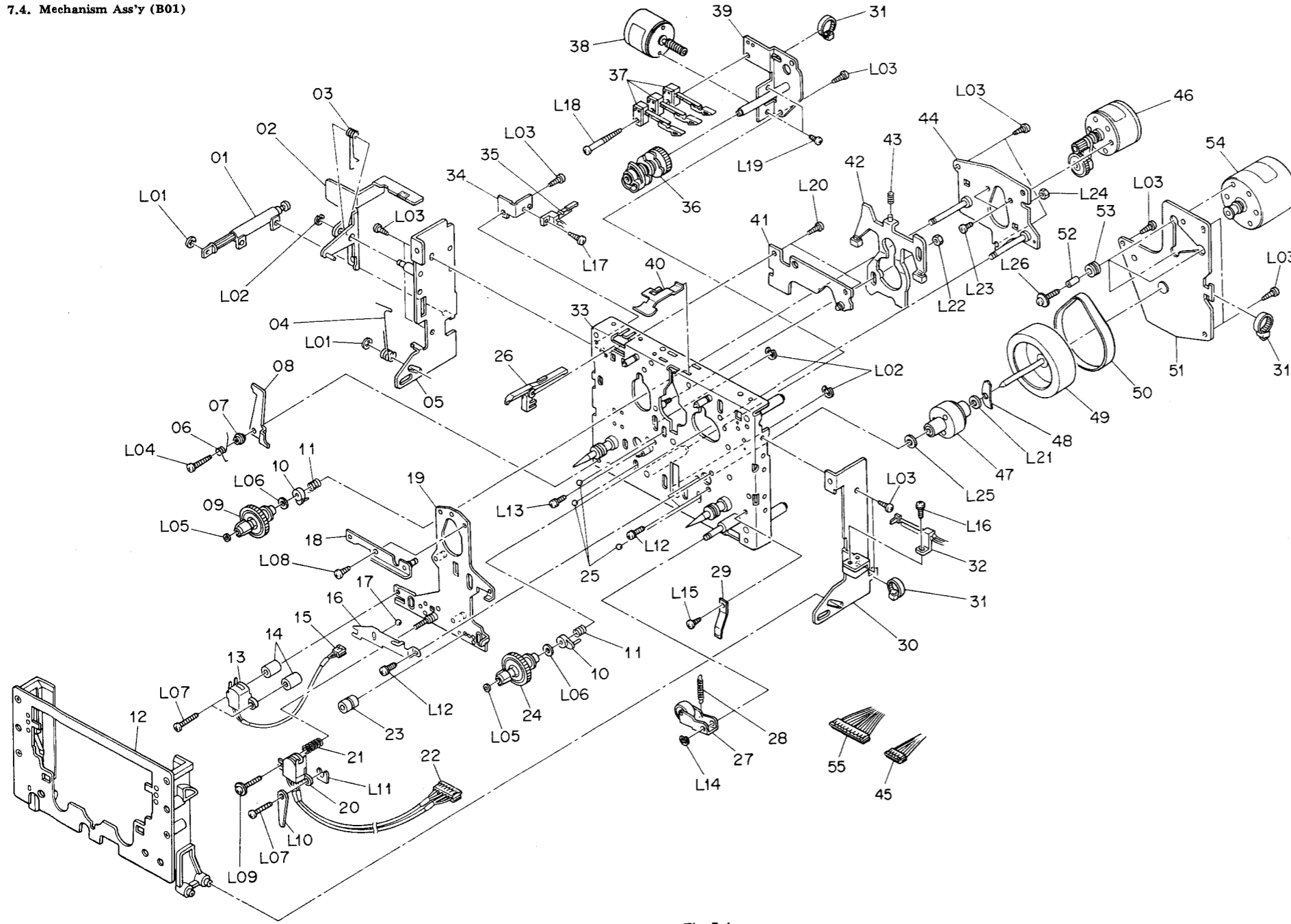

Fig. 7.4

Schematic Ref. No.	Part No.	Description	Qty
7.4. Mechanism Ass'y (B01)			
B01	CA08886A	Mechanism Ass'y Serial No.: A32501001 -	
01	CA80006A	Damper Ass'y	1
02	OC80021A	Eject Lever	1
03	OC82720A	Eject Lever Spring	1
04	OC80019B	Eject Spring	1
05	OC80018B	Cassette Case Holder L	1
06	OC80013A	Lock Lever Spring	1
07	OC80014A	Lock Lever Collar	1
08	OC82719A	Lock Lever B	1
09	CA80725A	Take-up Reel Hub Ass'y	1
10	OC80612A	Spring Holder	2
11	OC80613A	Reel Hub Spring	2
12	CA80001A	Cassette Case Ass'y	1
13	OG01365A	Erase Head E2D	1
14	OC80044A	Erase Head Collar	2
15	OC82704A	2P Connector for Erase Head	1
16	OC82710A	Head Base Hold Plate	1
17	OC80004A	Steel Ball 3mm	1
18	OC80005A	Reinforce Plate	1
19	OC82697A	Head Base B	1
20	OG01371A	Record/Playback Head 2G	1
21	OC82703A	Azimuth Adjust Spring	1
22	OC82705A	6P Connector for R/P Head	1
23	OC80045A	Record/Playback Head Collar	1
24	CA80726A	Supply Reel Hub Ass'y	1
25	OC80007A	Steel Ball 2mm	3
26	OC80017B	Record Protector Lever	1
27	CA80005A	Pressure Roller Ass'y	1
28	OC80008A	Pressure Roller Spring	1
29	OC80009A	Cassette Case Spring	1
30	OC80010D	Cassette Case Holder R	1
31	OC80037A	Insu-Lock	4
32	OC80012A	Eject Sensor Switch	1
33	OC82721A	Mechanism Chassis B	1
34	OC80025A	Record Protector Holder	1
35	OC80024A	Record Protector Switch	1
36	OC80026A	Cam	1
37	OC80027A	Mode Switch	3
38	CA80007A	Control Motor Ass'y	1
39	OC80028A	Control Motor Holder	1
40	OC82709A	Cassette Holder Spring	1
41	CA80011A	Shut-off P.C.B. Ass'y	1
42	CA80204A	Brake Ass'y B	1
43	OC80628A	Brake Spring	1
44	OC82722A	Reel Motor Holder B	1
45	OC82707A	5P Connector	1
46	CA80728A	Reel Motor Ass'y	1
47	OC80031A	Capstan Flange	1
48	OC80029A	Back Tension Spring	1
49	OC80033A	Flywheel	1
50	OC80034A	Capstan Belt	1
51	CA80009A	Flywheel Holder Ass'y	1
52	OC80035A	Sleeve	3
53	OC80036A	Floating Rubber	3
54	CA80010A	Capstan Motor Ass'y	1
55	OC82706A	9P Connector	1
L01	OE03052A	CS Stopper 2.4mm	2
L02	OE00181A	E-Ring 3mm	3
L03	OE03042A	FT2.5x5 @ Pan	11
L04	OE03043A	FT2.5x10 @ Pan	1
L05	OE03049A	Washer 1.8x3.2x0.5	2
L06	OE03226A	Washer 2.1x4.5x0.1	2
L07	OE03038A	M2x12 @ Binding	3
L08	OE03040A	FT2.5x3.5 @ Pan	1
L09	OE03436A	TP2x6	1
L10	OE03053A	Wire Holder	1
L11	OC80038A	Shim 0.06T	1
	OC80039A	Shim 0.1T	1
	OC80048A	Shim 0.03T	1
L12	OE03046A	M2.6x6 @ Pan (2A)	3
L13	OE03036A	M2x4 @ Pan (2A)	1
L14	OE00222A	E-Ring 2mm	1
L15	OE03035A	M2x3.2 @ Truss	1
L16	OE03037A	M2x5 @ Pan (2A)	1
L17	OE03048A	FT2.6x6 @ Pan	1
L18	OE03044A	FT2.5x20 @ Pan	1
L19	OE00691A	M2x3 @ Pan	2
L20	OE03041A	FT2.5x4 @ Pan	2
L21	OE03245A	Plastic Washer 1.3x3.3x0.3	1
L22	OE03237A	Nut Hex. M2.6	1
L23	OE03045A	M2.6x3 @ Binding	2
L24	OE00694A	Nut Hex. M2	1
L25	OE03051A	Washer 2.5x7x0.8	1
L26	OE03047A	M2.6x9 @ Pan	3

7.5 Front Escutcheon Ass'y (B02)

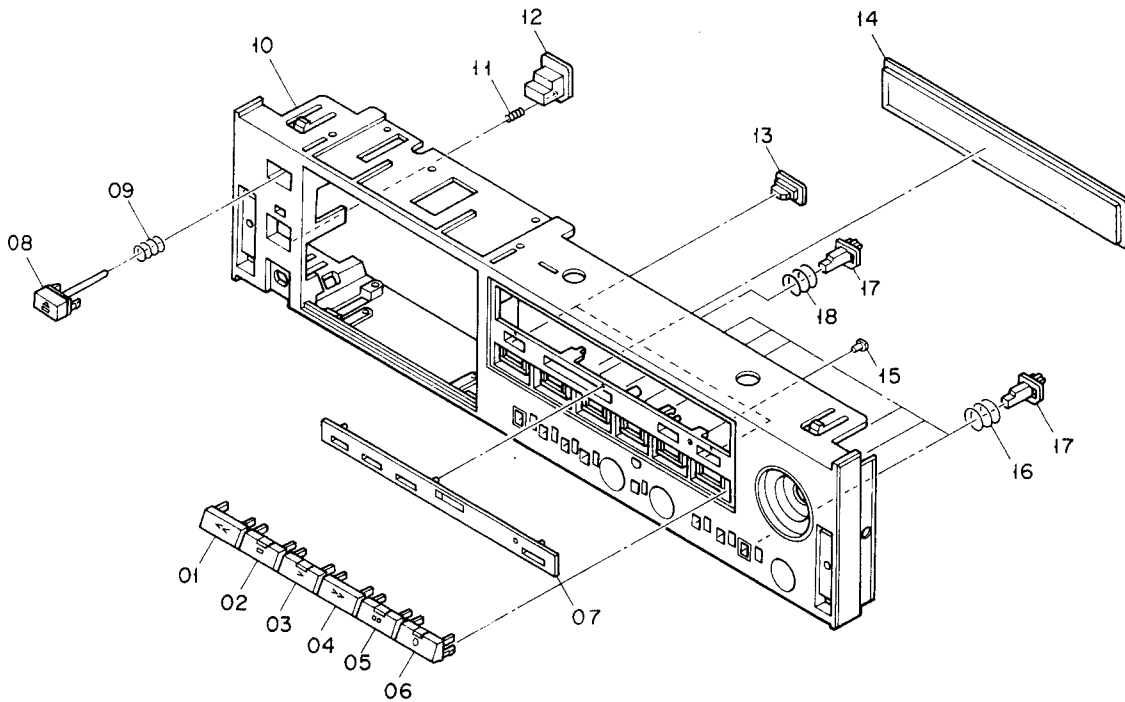

Fig. 7.5

Schematic Ref. No.	Part No.	Description	Q'ty
7.5. Front Escutcheon Ass'y (B02)			
B02	HA05308A	Front Escutcheon Ass'y Serial No.: A32501001 -	1
01	0H05126A	Rewind Button	1
02	HA05359A	Stop Button Ass'y	1
03	HA05343A	Play Button Ass'y	1
04	0H05129A	F.F. Button	1
05	HA05361A	Pause Button Ass'y	1
06	HA05360A	Rec. Button Ass'y	1
07	0H05100B	Function Plate	1
08	HA05344A	Eject Button Ass'y	1
09	0J05404A	Eject Spring	1
10	0H05122B	Front Escutcheon	1
11	0J05405A	Power Switch Spring	1
12	0H05125B	Power Switch Knob	1
13	0H05094A	Function Button	2
14	0H05101A	Display Lens	1
15	0H05103A	LED Lens B	1
16	0J05406A	Push Switch Spring	6
17	0H05097A	Push Button	7
18	0J05452B	EX Switch Spring	1
—	0J05458B	LED Lens Adhesive Tape	2
—	0J05459A	F. Plate Adhesive Tape	2

8. MOUNTING DIAGRAMS AND PARTS LIST

Notes: 1. Mounting diagram shows a dip side view of the printed circuit board.

2. Diode is 1SS53, 1S1555, or 1SS176 unless otherwise specified.

3. Following transistors are interchangeable with each other.

a. 2SA733, 2SA608SP, 2SA1048, 2SA1175

b. 2SC945, 2SC536SP, 2SC2458, 2SC2785

4. Abbreviation for part name:

TR — Transistor, SiD — Silicon Diode, ZD — Zener Diode

RK — Carbon Resistor, RM — Metal Film Resistor, RF — Fail Safe Type Resistor

CE — Electrolytic Capacitor, CML — Mylar Capacitor, CC — Ceramic Capacitor, CPP — PP Capacitor,

CMM — Metalized Mylar Capacitor, CSP — Polystyrene Capacitor, C — Mica Capacitor

8.1. Fuse P.C.B. Ass'y

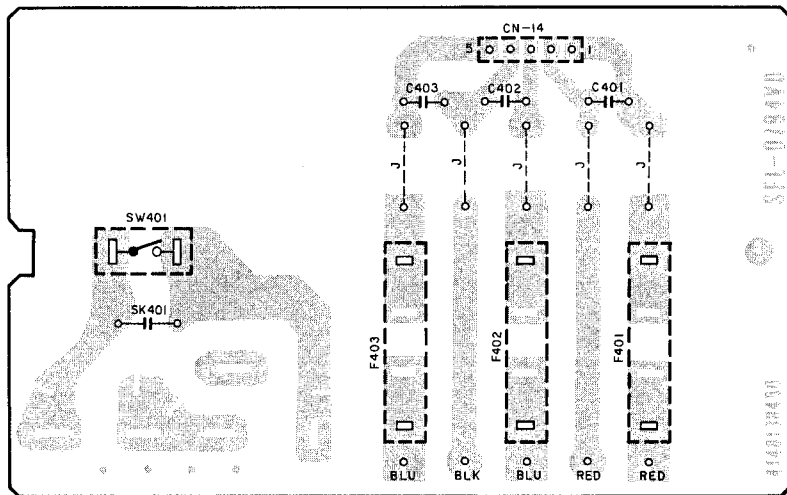

Fig. 8.1

8.2. Pin Jack P.C.B. Ass'y

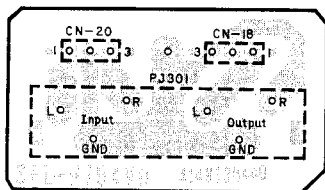

Fig. 8.2

8.3. Input Volume P.C.B. Ass'y

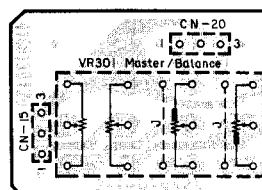

Fig. 8.3

Schematic Ref. No.	Part No.	Description	Schematic Ref. No.	Part No.	Description	Schematic Ref. No.	Part No.	Description
8.1. Fuse P.C.B. Ass'y			SK401	OB41826A	CC 4700P 250V (CR-20)	8.2. Pin Jack P.C.B. Ass'y		
	BA06964A	Fuse P.C.B. Ass'y (CR-2 & CR-2E)	CN14	OB83161A	5P Connector		BA06970A	Pin Jack P.C.B. Ass'y
	BA06963A	Fuse P.C.B. Ass'y (CR-2A)	SW401	OB71006A	Power Switch SDL1P		OB60497A	Pin Jack P.C.B.
	BA06965A	Fuse P.C.B. Ass'y (CR-20)		OB08349B	Fuse CHP (1)	PJ301	OB81755A	4P Pin Jack
C401,402	OB60502A	Fuse P.C.B.		OM04131B	Fuse Label T1A 250Vx2 (CR-2 & CR-2E) (1)	CN20	OW19300A	Wire 2791 24 300 WHT with Shrink Tube
C403	OB09292A	CC 0.1μ 50V Z		OM05082A	Fuse Label T800mA 250V (CR-2 & CR-2E) (1)		8.3. Input Volume P.C.B. Ass'y	
F401	OB90287A	Fuse T800mA (CR-2 & CR-2E)		OB81776A	Contact Pin (CR-2 & CR-2E) (5)		BA06966A	Input Volume P.C.B. Ass'y
F401	OB90286A	Fuse 1.0A (CR-2A)				VR301	OB60498A	Input Volume P.C.B
F401	OB90290A	Fuse 1A (CR-20)					OB30077A	Volume 100KAx2
F402,403	OB90289A	Fuse T1A (CR-2 & CR-2E)					0J05419A	Volume Ground Plate (1)
F402,403	OB90285A	Fuse 1.6A (CR-2A)					0V10050C	Wire 1007 26 Twisted 52 BLK C (1)
SK401	OB90291A	Fuse 1.6A (CR-20)						
	OB41829A	CC 4700P 400V (CR-2, CR-2A & CR-2E)						

8.4. Output Volume P.C.B. Ass'y

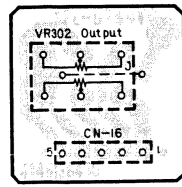

Fig. 8.4

8.5. Headphone P.C.B. Ass'y

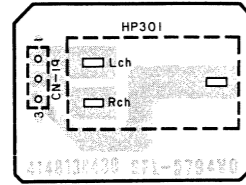

Fig. 8.5

8.6. Bias Tune Volume P.C.B. Ass'y

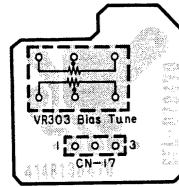

Fig. 8.6

8.7. Shut-off P.C.B. Ass'y

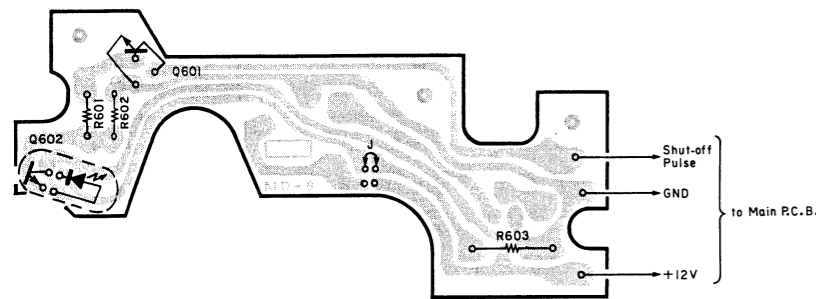

Fig. 8.7

8.8. Control P.C.B. Ass'y

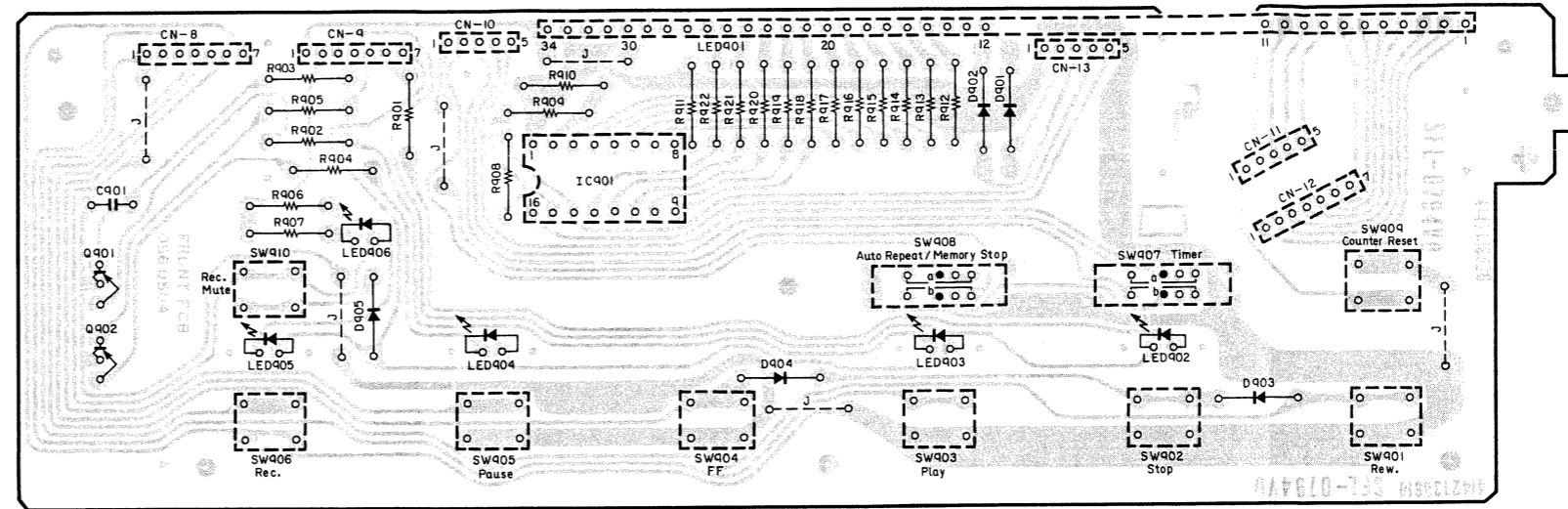

Fig. 8.8

Schematic Ref. No.	Part No.	Description	Schematic Ref. No.	Part No.	Description
8.4. Output Volume P.C.B. Ass'y			8.6. Bias Tune Volume P.C.B. Ass'y		
VR302	BA06967A	Output Volume P.C.B. Ass'y	VR303	BA06968A	Bias Tune Volume P.C.B. Ass'y
	OB60499A	Output Volume P.C.B.		OB60500A	Bias Tune Volume P.C.B.
	OB30078A	Volume 10Kx2		OB30079A	Volume 100Kx2
	OJ05419A	Volume Ground Plate (1)		OJ05419A	Volume Ground Plate (1)
	0V10050C	Wire 1007 26 Twisted 52 BLK C (1)		0V10050C	Wire 1007 26 Twisted 52 BLK C (1)
8.5. Headphone P.C.B. Ass'y			8.7. Shut-off P.C.B. Ass'y		
HP301	BA06969A	Headphone P.C.B. Ass'y	Q601 Q602 R601 R602 R603	CA80011A	Shut-off P.C.B. Ass'y
	OB60501A	Headphone P.C.B.		OC80047A	Shut-off P.C.B. TR 2SC2812
OB81757A	Headphone Jack	OB06388A		Photo Reflector NJL5141	
		OB06389A		RK 680	
		OB09840A		RK 15K	
		OB09841A		RM 750	
		OC81330A	OV13130N		
		OC81334A	OV10115N		
		OC81335A			

Schematic Ref. No.	Part No.	Description	Schematic Ref. No.	Part No.	Description
8.8. Control P.C.B. Ass'y			SW901,902	OB70043A	Tact Switch SKHHPM
	BA06961A	Control P.C.B. Ass'y	SW903,904	OB70043A	Tact Switch SKHHPM
IC901	OB60504A	Control P.C.B. IC TA7612AP	SW905,906	OB70043A	Tact Switch SKHHPM
Q901,902	OB06013A	TR 2SA733 (P,Q)	SW907,908	OB07437A	Slide Switch ESD-14150
D901,902	OB12584A	SiD 1N4148	SW909,910	OB70043A	Tact Switch SKHHPM
D903,904	OB12584A	SiD 1N4148	CN8	OB83155A	7P Connector
D905	OB12584A	SiD 1N4148	CN9	OB83156A	7P Connector
LED901	OB12575A	Display Unit SL-7663-03	CN10	OB83157A	5P Connector
LED902,903	OB12578A	LED SLR-34PC4F	CN11	OB83159A	5P Connector
LED904	OB12578A	LED SLR-34PC4F	CN12	OB83160A	7P Connector
LED905	OB12577A	LED SLR-34DC4F	CN13	OB83158A	5P Connector
LED906	OB12579A	LED SLR-320DC4F		OJ05416A	LED Reflector (4)
R901	OB05578A	RK 180 1/4W J			
R902	OB09797A	RK 120 1/4W J			
R903	OB01846A	RK 4.7K 1/4W J			
R904	OB09797A	RK 120 1/4W J			
R905	OB01846A	RK 4.7K 1/4W J			
R906	OB20416A	RK 110 1/4W J			
R907	OB01706A	RK 47 1/4W J			
R908	OB09314A	RK 5.1K 1/4W J			
R909	OB01857A	RK 1K 1/4W J			
R910	OB20430A	RK 160 1/4W J			
R911	OB01888A	RK 10K 1/4W J			
R912	OB05795A	RK 150 1/4W J			
R913,914	OB01679A	RK 100 1/4W J			
R915,916	OB01679A	RK 100 1/4W J			
R917,918	OB01679A	RK 100 1/4W J			
R919,920	OB01679A	RK 100 1/4W J			
R921,922	OB01679A	RK 100 1/4W J			
C901	OB05557A	CML 0.015μ 50V J			

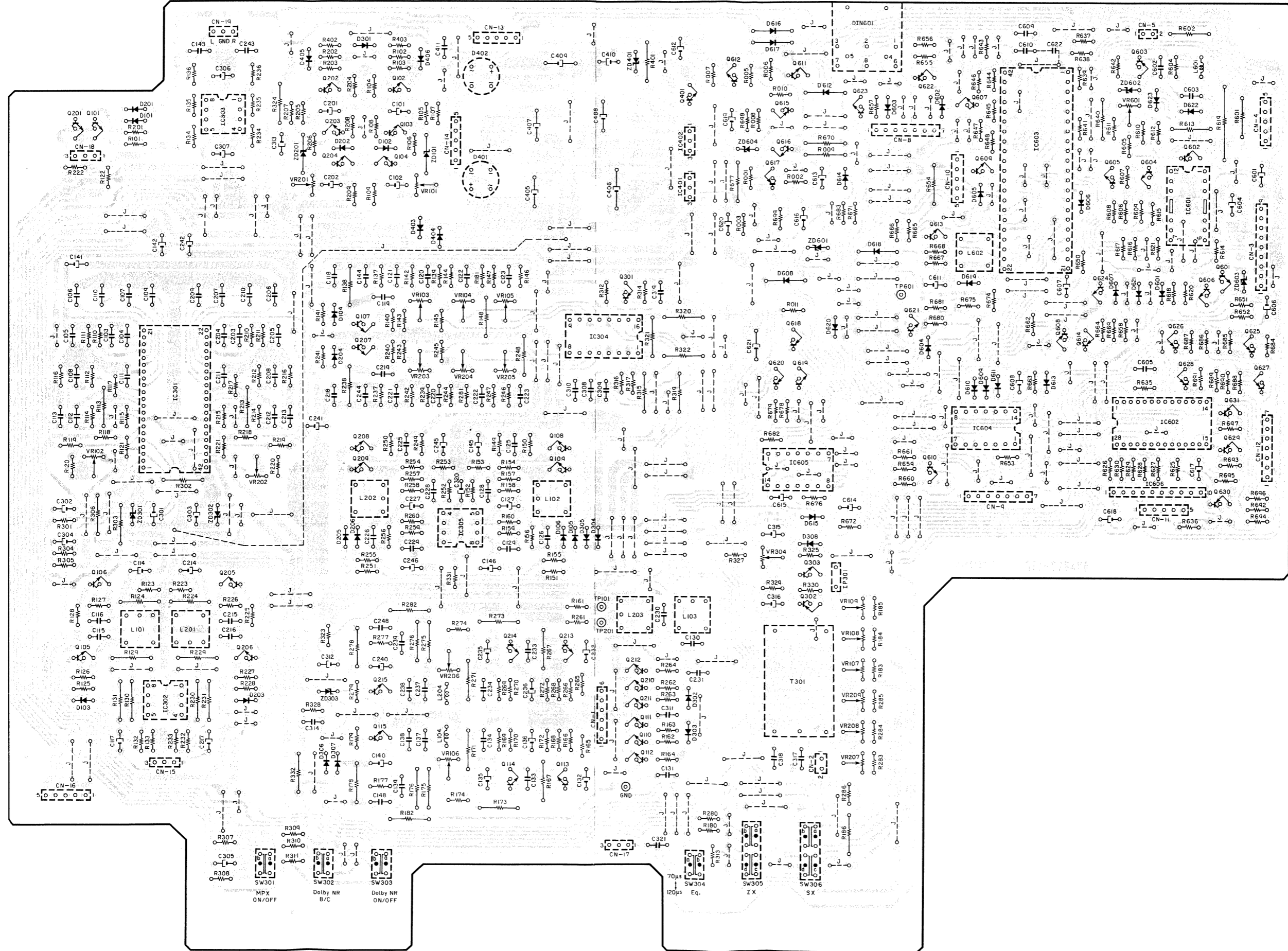

Fig. 8.9

9. SCHEMATIC DIAGRAM

9.1. IC Block Diagrams

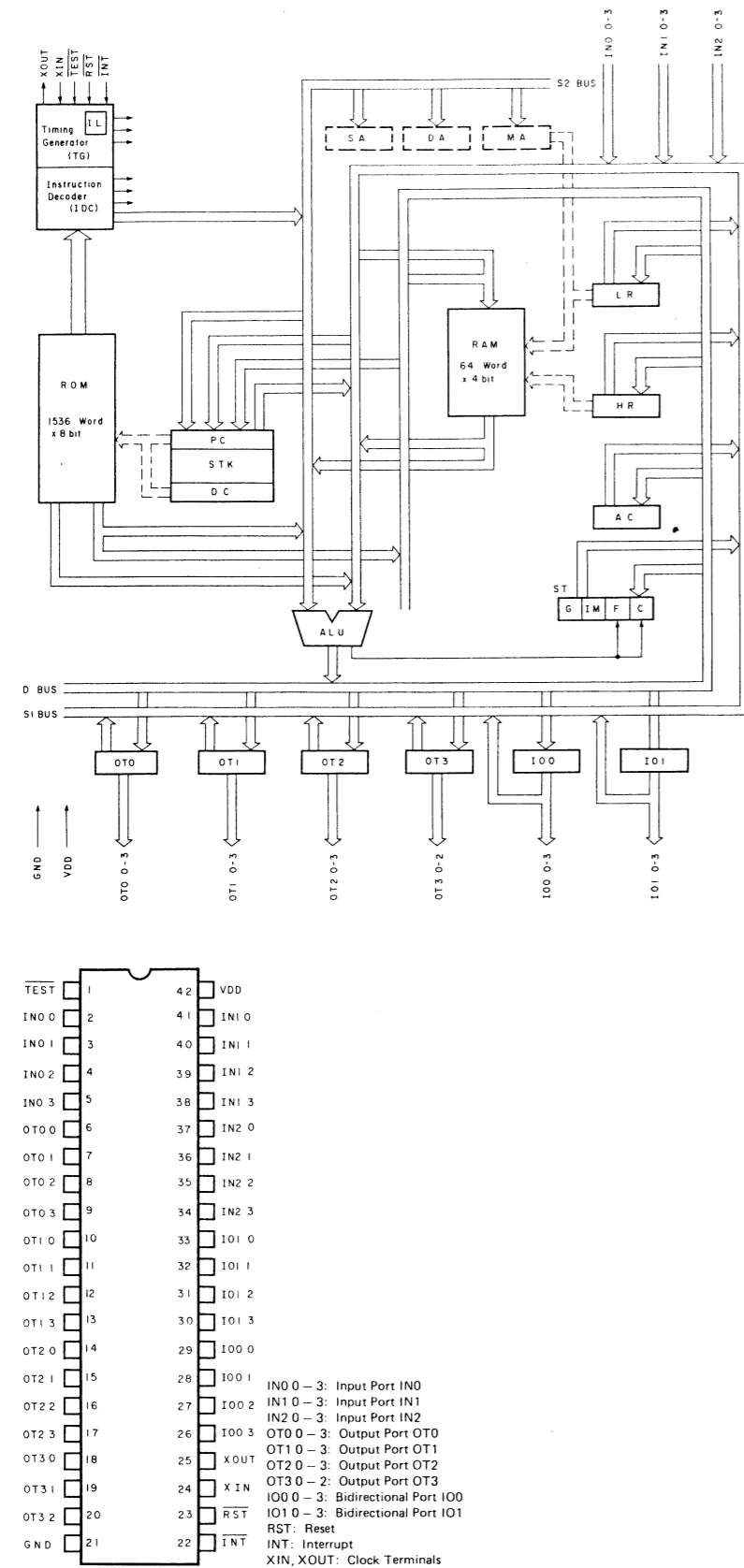

Fig. 9.1.1 4-Bit Micro-processor TMP4315BP-1814

IC603 (TMP4315BP-1814)

Pin No.	Signal Name	In/Out	Function
1	Test	—	Not used.
2	Cam (0)	In	Mechanism position detecting signals.
3	Cam (1)	In	Mechanism mode can be sensed according to states of Cam (0), Cam (1) and Cam (2).
4	Cam (2)	In	
5	Eject	In	Eject signal. Active L. Used to detect whether the Cassette Case is open. When it is open, this signal is L. In this condition, the CR-2 is in Stop mode and no pushbutton operation is enabled.
6	R.M. Fwd.	Out	Reel Motor Forward signal. Active L. Reel Motor Running (Forward)
7	R.M. Rev.	Out	Reel Motor Reverse signal. Active L. Reel Motor Running (Reverse)
8	C.M. Fwd.	Out	Control Motor Forward signal. Active L. Control Motor Running (Forward)
9	C.M. Rev.	Out	Control Motor Reverse signal. Active L. Control Motor Running (Reverse)
10	R.M. Play	Out	Reel Motor Play signal. Active H. In Play mode, C.M. Fwd. becomes L, and R.M. Play becomes H. Reel Motor Running (Play)
11	Capstan M	Out	Capstan Motor Run signal. Active H. In Play, Pause, or Rec./Play mode, Capstan M is H and Capstan Motor runs. In other modes, Capstan M is L, so Capstan Motor is stopped. Capstan Motor Running (Play, Pause, Rec./Play)
12	E. Brake	Out	Electric Brake signal. Active H. Generates H pulse upon change in mode. F.F. Button ON Mode: Rew. F.F. E. Brake: H pulse

Pin No.	Signal Name	In/Out	Function
13	Source Mute	Out	Source Mute signal. Active H. Issues H pulse for 3.3 sec after power is turned ON.
14	Line Mute	Out	Line Output Mute signal. Active H. Stays at L only in Play or Rec./Play mode. Deactivates mute of line outputs.
15	Rec. Mute	Out	Record Mute signal. Active H. Stays at L only in Rec./Play mode. Releases record mute.
16	Rew. Mode	Out	Rewind Mode signal. Active L.
17	F.F. Mode	Out	F.F. Mode signal. Active L.
18	Pause Mode	Out	Pause Mode signal. Active L. Used for lighting of Pause lamp.
19	Play Mode	Out	Play Mode signal. Active L. Used for lighting of Play lamp.
20	Rec. Mode	Out	Record Mode signal. Active L. Used for lighting of Record lamp.
21	Vss	In	GND.
22	INT	In	Interrupt signal. Active L. Allows input of shut-off pulse train. Detects tape running, i.e., rotation of Take-up Reel Hub.
23	Reset	In	Reset signal. Active L. Held at L for approx. 100 msec after power is turned ON. Upon change of this signal to H, IC603 starts operation.
24	EXTal	In	External circuit for clock oscillation.
25	Xtal	In	Oscillating frequency = 550 kHz.
26	Rec.	—	Not used.
27	AMS	—	Not used.
28	Zero	In	Not used.
29	Memory	In	Memory Switch ON signal. Active H. Held at H when Memory switch is set to ON. (With this switch set to ON, tape will stop automatically when the tape counter indication "000" is reached during rewind or fast-forward.)

Pin No.	Signal Name	In/Out	Function
30	A. Rew.	In	Auto Rewind and Auto Play signal. Active L.
31	A. Play	In	These signals are L when Timer set to OFF and, at the same time Repeat switch is set to ON. (With these signals set to L, auto function is performed and the rewind cycle is continuously repeated between the tape end and the timer. Furthermore, if Memory switch ON, the play/rewind is continuously repeated between end and the tape counter in "000".)
32	T. Rec.	In	Timer Recording signal. Active L. When power is turned ON with switch in Record position, be for approx. 3.3 sec, causing un recording to start.
33	T. Play	In	Timer Play signal. Active L. Held at L upon setting of Timer to the Play position.
34	K. Pause	In	Pause button input terminal. Be upon push of Pause button.
35	K. Rec.	In	Record button input terminal. L upon push of Record button.
36	R. Mute	—	Not used.
37	SEA	—	Not used.
38	K. Play	In	Play button input terminal. Be upon push of Play button.
39	K. F.F.	In	F.F. button input terminal. Be upon push of F.F. button.
40	K. Rew.	In	Rewind button input terminal. L upon push of Rewind button.
41	K. Stop	In	Stop signal input terminal. At all operations.
42	VDD	In	+5 V.

9. SCHEMATIC DIAGRAM

9.1. IC Block Diagrams

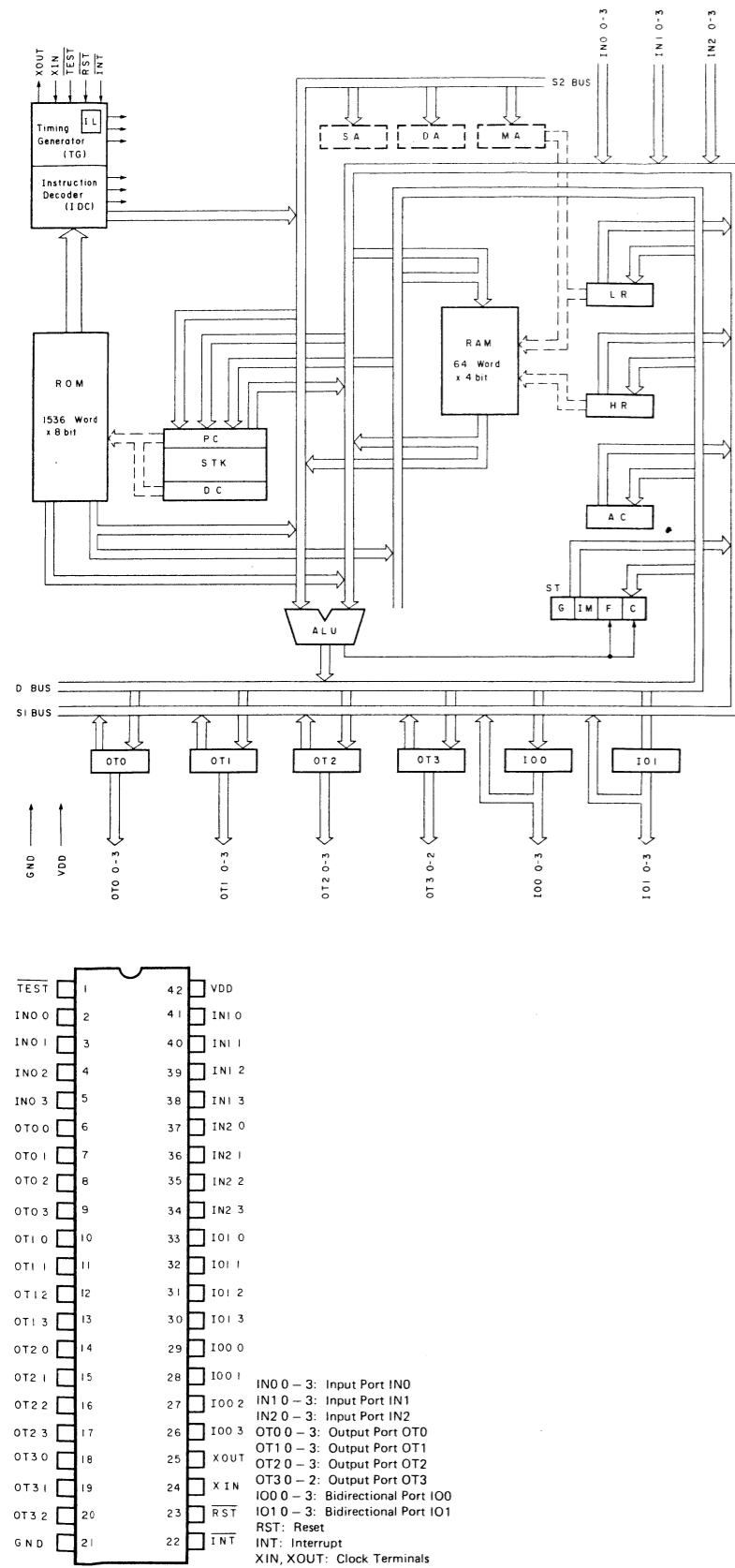

IC603 (TMP4315BP-1814)

Pin No.	Signal Name	In/Out	Function
1	Test	—	Not used.
2	Cam (0)	In	Mechanism position detecting signals.
3	Cam (1)	In	Mechanism mode can be sensed according to states of Cam (0), Cam (1) and Cam (2).
4	Cam (2)	In	
5	Eject	In	Eject signal. Active L. Used to detect whether the Cassette Case is open. When it is open, this signal is L. In this condition, the CR-2 is in Stop mode and no pushbutton operation is enabled.
6	R.M. Fwd.	Out	Reel Motor Forward signal. Active L. Reel Motor Running (Forward)
7	R.M. Rev.	Out	Reel Motor Reverse signal. Active L. Reel Motor Running (Reverse)
8	C.M. Fwd.	Out	Control Motor Forward signal. Active L. Control Motor Running (Forward)
9	C.M. Rev.	Out	Control Motor Reverse signal. Active L. Control Motor Running (Reverse)
10	R.M. Play	Out	Reel Motor Play signal. Active H. In Play mode, C.M. Fwd. becomes L, and R.M. Play becomes H. C.M. Fwd. L R.M. Play H Reel Motor Running (Play)
11	Capstan M	Out	Capstan Motor Run signal. Active H. In Play, Pause, or Rec./Play mode, Capstan M is H and Capstan Motor runs. In other modes, Capstan M is L, so Capstan Motor is stopped. Capstan Motor Running (Play, Pause, Rec./Play)
12	E. Brake	Out	Electric Brake signal. Active H. Generates H pulse upon change in mode. F.F. Button ON Mode Rew. F.F. E. Brake H

Pin No.	Signal Name	In/Out	Function
13	Source Mute	Out	Source Mute signal. Active H. Issues H pulse for 3.3 sec after power is turned ON. Used for timer recording circuit. Power ON H Approx. 3.3 sec L
14	Line Mute	Out	Line Output Mute signal. Active H. Stays at L only in Play or Rec./Play mode. Deactivates mute of line outputs.
15	Rec. Mute	Out	Record Mute signal. Active H. Stays at L only in Rec./Play mode. Releases record mute.
16	Rew. Mode	Out	Rewind Mode signal. Active L.
17	F.F. Mode	Out	F.F. Mode signal. Active L.
18	Pause Mode	Out	Pause Mode signal. Active L. Used for lighting of Pause lamp.
19	Play Mode	Out	Play Mode signal. Active L. Used for lighting of Play lamp.
20	Rec. Mode	Out	Record Mode signal. Active L. Used for lighting of Record lamp.
21	Vss	In	GND.
22	INT	In	Interrupt signal. Active L. Allows input of shut-off pulse train. Detects tape running, i.e., rotation of Take-up Reel Hub.
23	Reset	In	Reset signal. Active L. Held at L for approx. 100 msec after power is turned ON. Upon change of this signal to H, IC603 starts operation. Power ON H Approx. 100 msec L
24	EXtal	In	External circuit for clock oscillation.
25	Xtal	In	Oscillating frequency = 550 kHz.
26	Rec.	—	Not used.
27	AMS	—	Not used.
28	Zero	In	Not used.
29	Memory	In	Memory Switch ON signal. Active H. Held at H when Memory switch is set to ON. (With this switch set to ON, tape will stop automatically when the tape counter indication "000" is reached during rewind or fast-forward.)

Pin No.	Signal Name	In/Out	Function
30	A. Rew.	In	Auto Rewind and Auto Play signals. Active L.
31	A. Play	In	These signals are L when Timer switch is set to OFF and, at the same time, Auto Repeat switch is set to ON. (With these signals set to L, auto repeat function is performed and the playback/rewind cycle is continuously repeated between the tape end and the tape start. Furthermore, if Memory switch is set to ON, the playback/rewind cycle is continuously repeated between the tape end and the tape counter indication "000".)
32	T. Rec.	In	Timer Recording signal. Active L. When power is turned ON with Timer switch in Record position, becomes L for approx. 3.3 sec, causing unattended recording to start.
33	T. Play	In	Timer Play signal. Active L. Held at L upon setting of Timer switch to the Play position.
34	K. Pause	In	Pause button input terminal. Becomes L upon push of Pause button.
35	K. Rec.	In	Record button input terminal. Becomes L upon push of Record button.
36	R. Mute	—	Not used.
37	SEA	—	Not used.
38	K. Play	In	Play button input terminal. Becomes L upon push of Play button.
39	K. F.F.	In	F.F. button input terminal. Becomes L upon push of F.F. button.
40	K. Rew.	In	Rewind button input terminal. Becomes L upon push of Rewind button.
41	K. Stop	In	Stop signal input terminal. At L, stops all operations.
42	VDD	In	+5 V.

Fig. 9.1.1 4-Bit Micro-processor TMP4315BP-1814

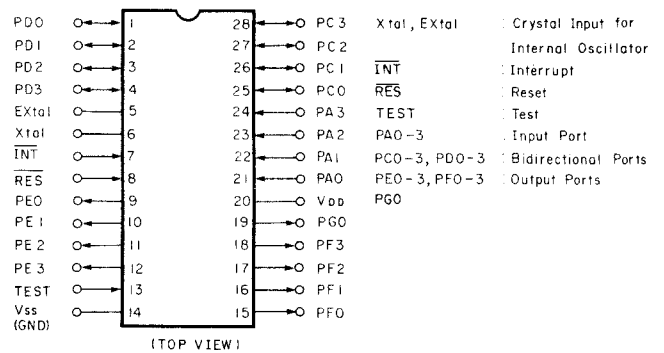
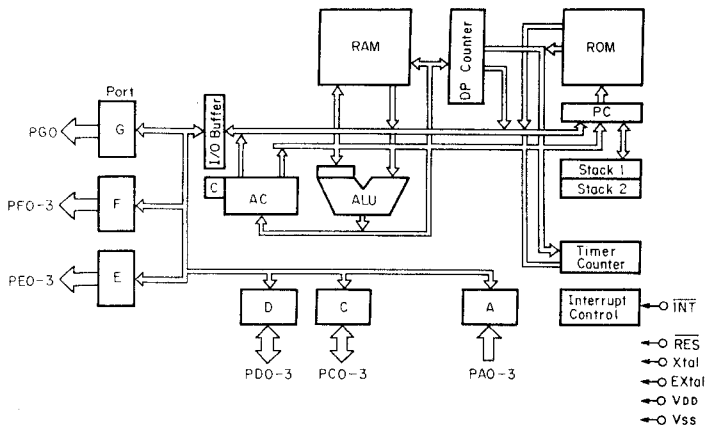
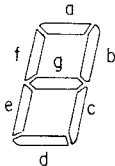

Fig. 9.1.2 4-Bit Micro-processor LM6416E-106

IC602 (LM6416E-106)

Pin No.	Signal Name	In/Out	Function
1	CLR	In	Reset button input terminal. Upon push of Reset button, Reset signal becomes L and counter is cleared to "0000".
2	K. Play	In	Play button input terminal. Becomes L upon push of Play button.
3	K. F.F.	In	F.F. button input terminal. Becomes L upon push of F.F. button.
4	K. Rew.	In	Rewind button input terminal. Becomes L upon push of Rewind button.
5	EXtal	In	Terminals for clock oscillation. RC circuit is connected.
6	Xtal	In	
7	INT	In	Interrupt signal. Active L. Shut-off pulse train is input. Input pulse train is counted for tape counter display.
8	Reset	In	Reset signal. Active L. Held at L for approx. 100 msec after power is turned ON.
9	f	Out	Display segment drive signals. Segment lights at L.
10	b		
11	a		
12	d		



13	Test	In	Not used.
14	Vss	In	GND.
15	g	Out	Display segment drive signals. Segment lights at L.
16	a		
17	c		
18	D4	Out	The 4th (rightmost) digit select signal. Active L.

Pin No.	Signal Name	In/Out	Function
19	Motor Slow	Out	Motor Slow signal. Active L. When Motor Slow signal is L, reel motor speed is reduced.

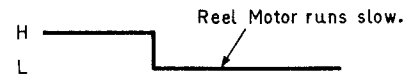

20	VDD	In	+5 V
21	L. Rew.	In	LED Rewind signal. Active L. When mode is changed to Rewind, L. Rew. signal becomes L after H period of E. Brake signal ended.

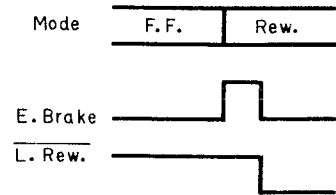

22	L. F.F.	In	LED F.F. signal. Active L. Timing is similar to L. Rew. signal.
23	L. Stop	In	LED Stop signal. Active L. Timing is similar to L. Rew. signal.
24	Memory Stop	In	Memory Stop switch input terminal of Memory Stop/Auto Repeat switch. Memory Stop signal is L when Memory Stop is selected.
25	Memory Play	In	Not used.
26	D3	Out	The 3rd, 2nd, and 1st (leftmost) digit select signals. Active L.
27	D2		
28	D1		

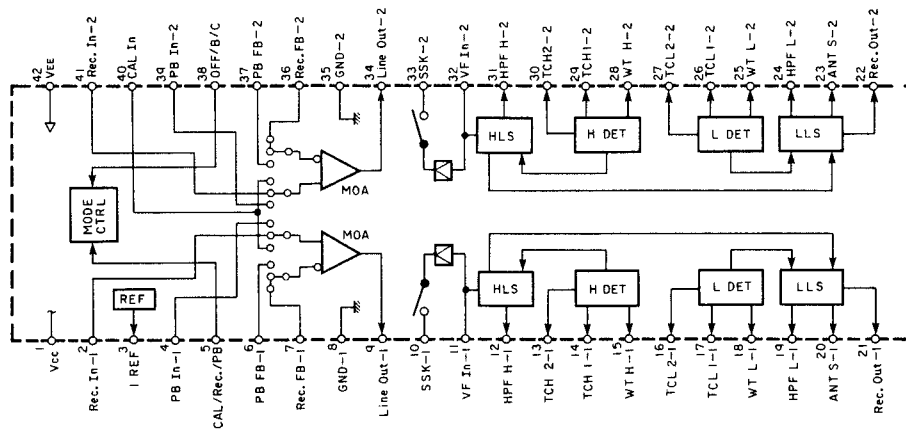

Fig. 9.1.3 Dolby NR IC CX20188

IC301 (CX20188)

<u>Pin No.</u>	<u>Signal Name</u>	<u>Function</u>
1	Vcc	Positive power supply input terminal.
2,41	Rec. In	Record signal input terminal.
3	I Ref.	Reference current input terminal.
4,39	PB In	PB signal input terminal.
5	CAL/Rec./PB	Calibration/Recording/Playback select terminal.
6,37	PB FB	Playback signal feedback terminal.
7,36	Rec. FB	Record signal feedback terminal.
8,35	GND	GND terminal.
9,34	Line Out	Line signal (decoded signal) output terminal.
10,33	SSK	Spectral skewing switch terminal.
11,32	VF In	Encode circuit input terminal.
12,31	HPF H	HLS high-pass filter terminal.
13,30	TCH 2	HLS detector time constant determination terminal 2.
14,29	TCH 1	HLS detector time constant determination terminal 1.
15,28	WT H	HLS weighting terminal.
16,27	TCL 2	LLS detector time constant determination terminal 2.
17,26	TCL 1	LLS detector time constant determination terminal 1.
18,25	WT L	LLS weighting terminal.
19,24	HPF L	LLS high-pass filter terminal.
20,23	ANT S	Anti-saturation terminal.
21,22	Rec. Out	Record signal (encoded signal) output terminal.
38	OFF/B/C	Dolby NR OFF/B-type/C-type select terminal.
40	CAL In	Calibration input terminal. Not used.
42	VEE	Negative power supply input terminal.

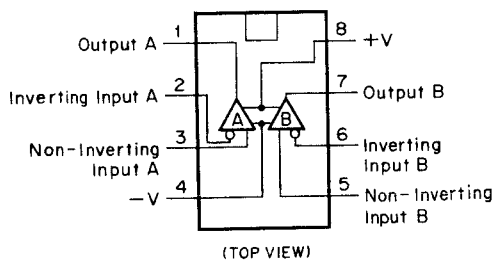

Fig. 9.1.4 Operational Amp. IC 4556D, 4558DD, 2043DD

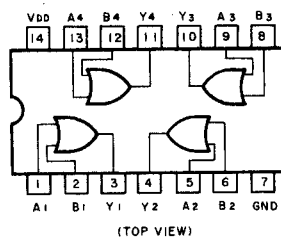

Fig. 9.1.5 OR Gate C-MOS IC μPD4071BC

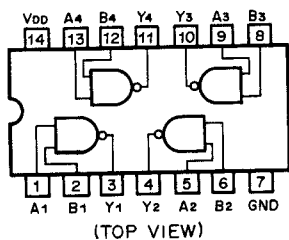

Fig. 9.1.6 NAND Gate C-MOS IC μPD4011BC

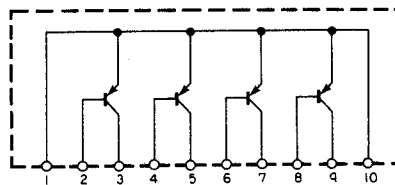
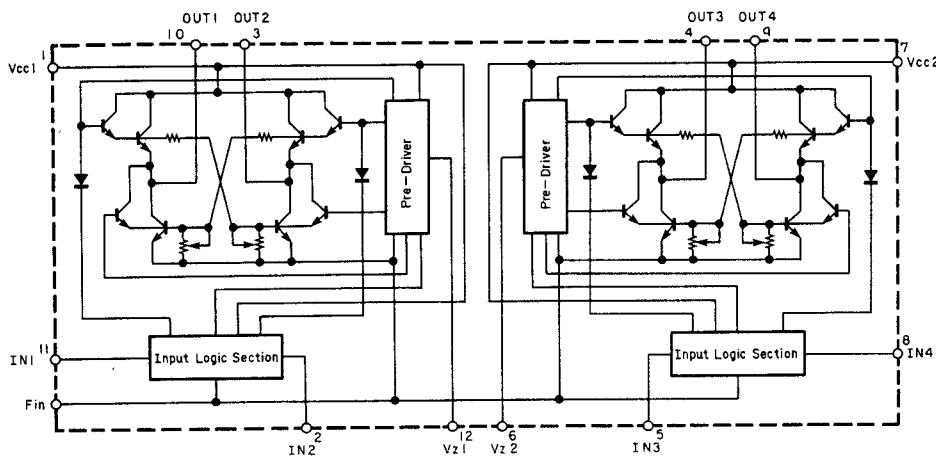

Fig. 9.1.7 Transistor Array TA64



INPUT		OUTPUT		OPERATION
IN1/3	IN2/4	OUT1/3	OUT2/4	
0	0	0	0	Braking
1	0	1	0	Forward (Reverse)
0	1	0	1	Reverse (Forward)
1	1	0	0	Braking

Fig. 9.1.8 Motor Driver IC LB1649

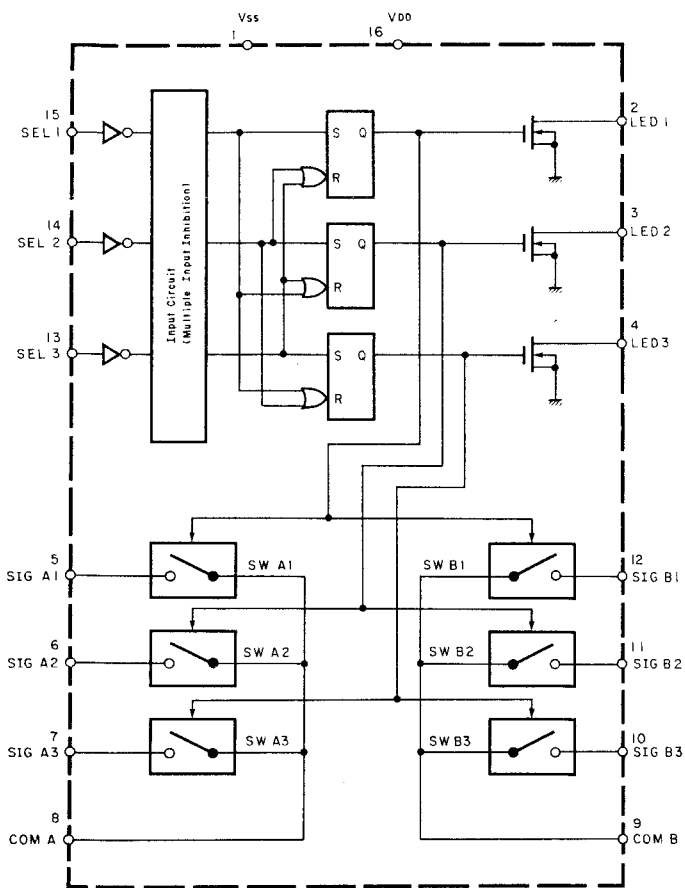

Fig. 9.1.9 Analog Switch Selector TC9145P

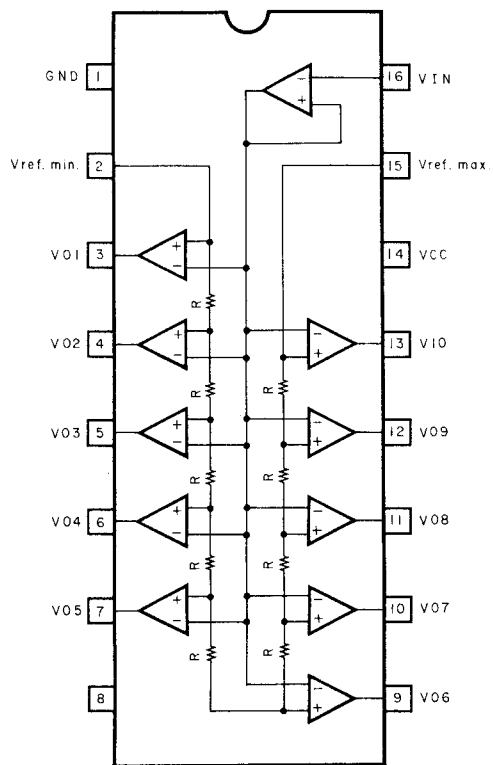
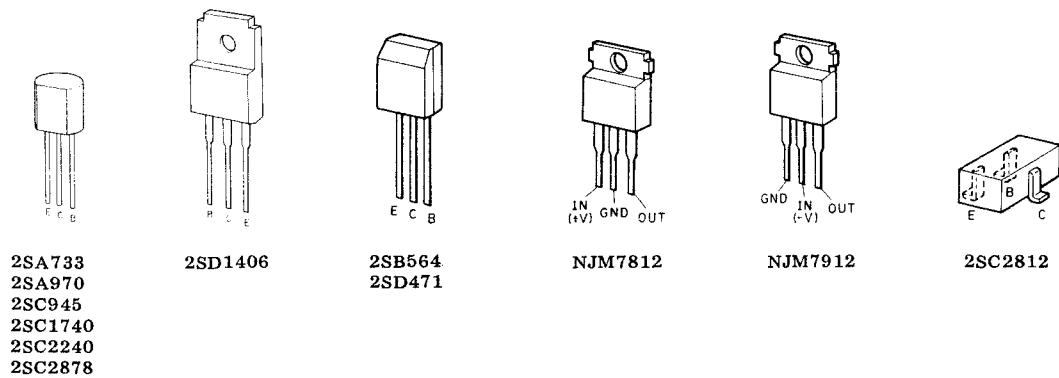

Fig. 9.1.10 Level Meter Driver TA7612AP



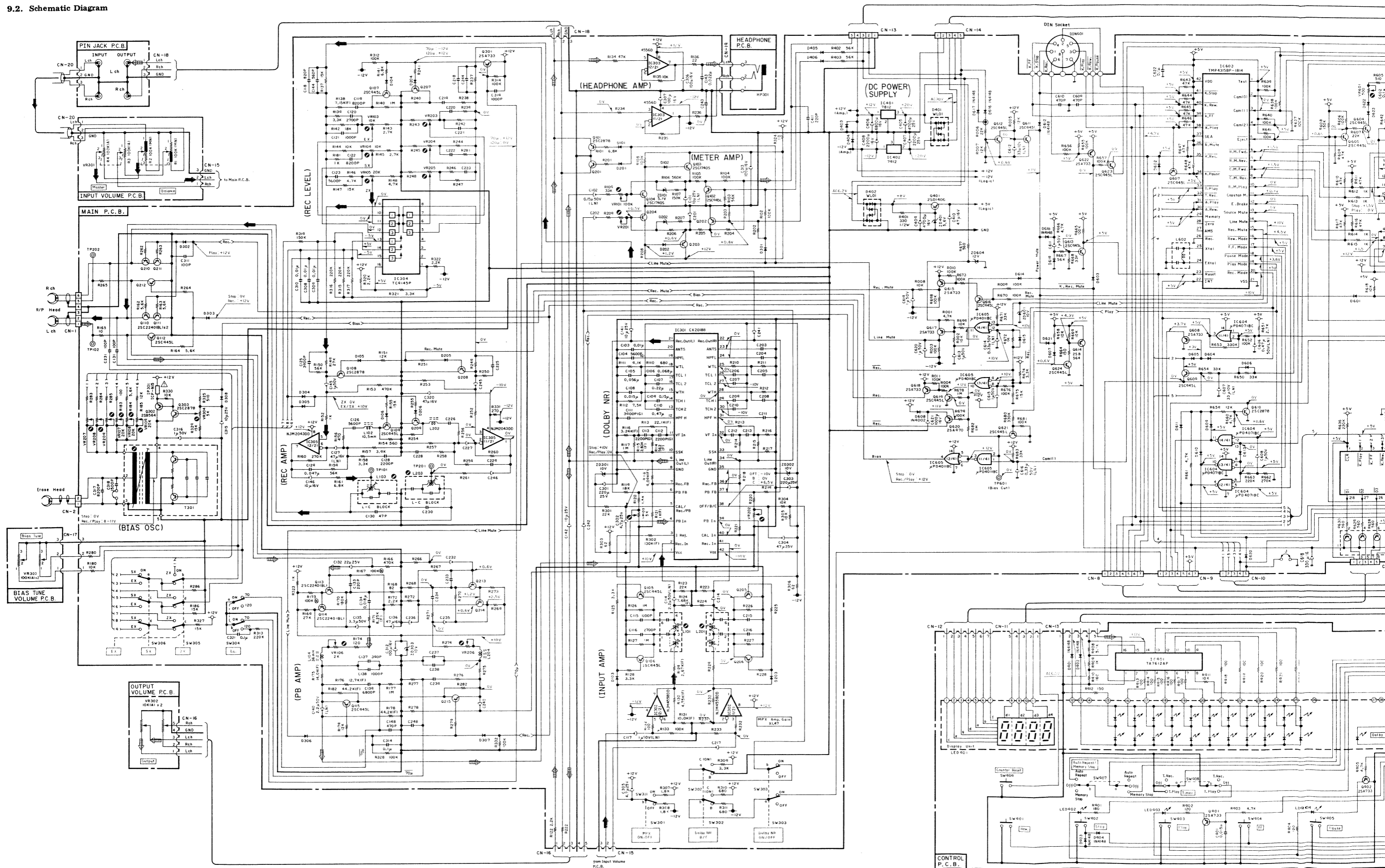
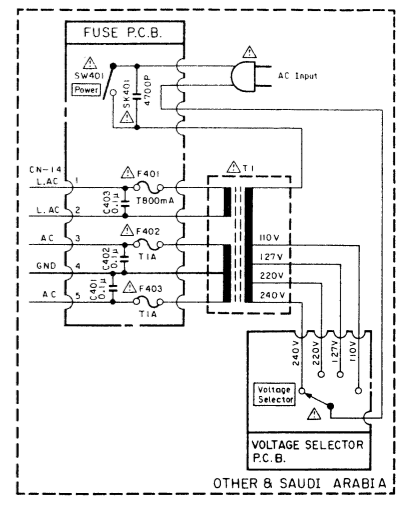
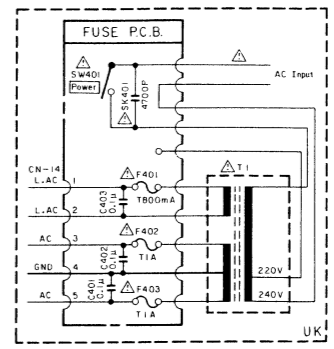
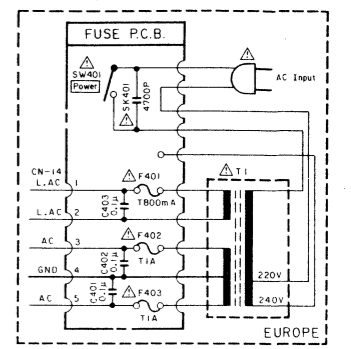
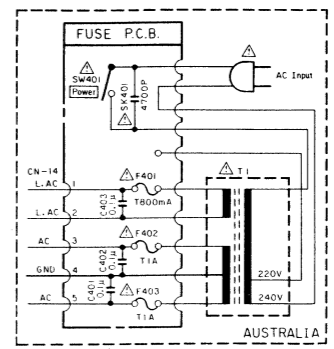
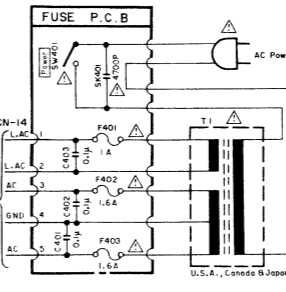
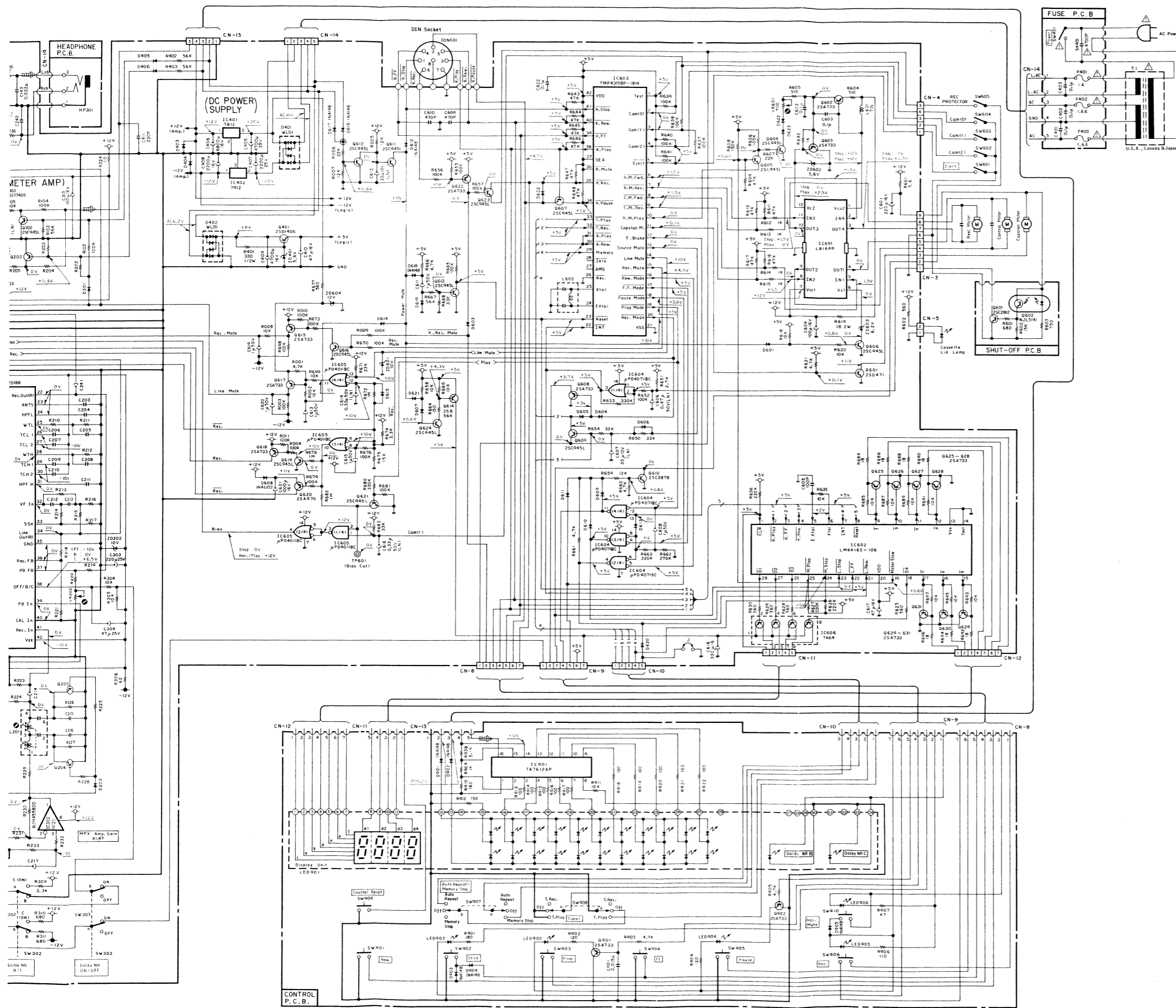



Fig. 9.2



WARNING:
 Parts marked with the symbol  have critical characteristics. Use **ONLY** replacement parts recommended by the manufacturer. It is recommended that the unit be operated from a suitable DC supply or batteries during initial check-out procedures.

CAUTION:
 Before returning the unit to the customer, make sure you make either (1) a leakage current check or (2) a line to chassis resistance check. If the leakage current exceeds 0.5 milliamp, or if the resistance from chassis to either side of the power cord is less than 240 k ohms, the unit is defective. **WARNING — DO NOT** return the unit to the customer until the problem is located and corrected.

- Notes:**
- Diode is 1SS53, 1S1555, or 1SS176 unless otherwise specified.
 - 2SA733, 2SA608SP, 2SA1048 and 2SA1175 are interchangeable with each other.
 - 2SC945, 2SC536SP, 2SC2458 and 2SC2785 are interchangeable with each other.
 - Voltage measuring condition:
 - Stop mode (with no input signal) unless otherwise specified.
 - Bias: ZX position, Eq: 70 μ s
 - Timer Switch: OFF
 - Memory Stop/Auto Repeat Switch: OFF
 - Play mode: Cassette with no tape played back.

Fig. 9.2

10. WIRING DIAGRAM

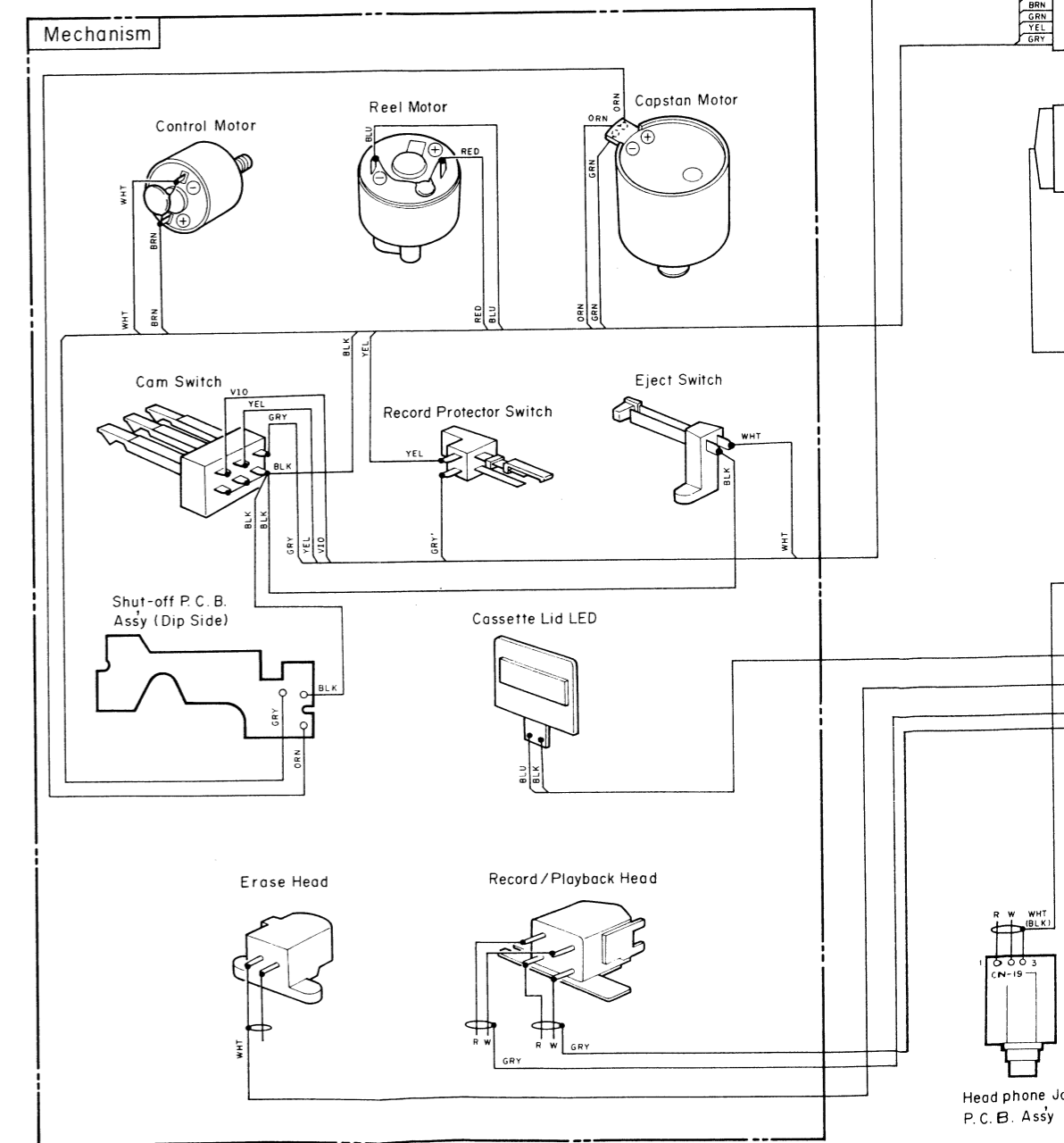
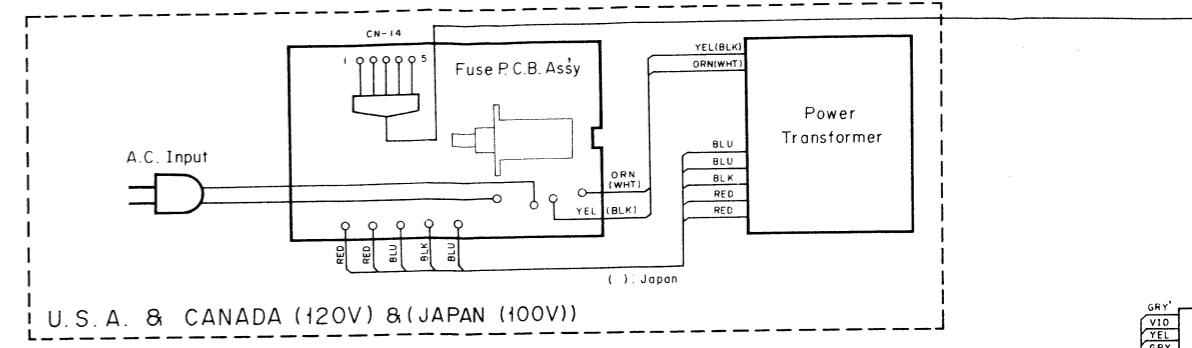
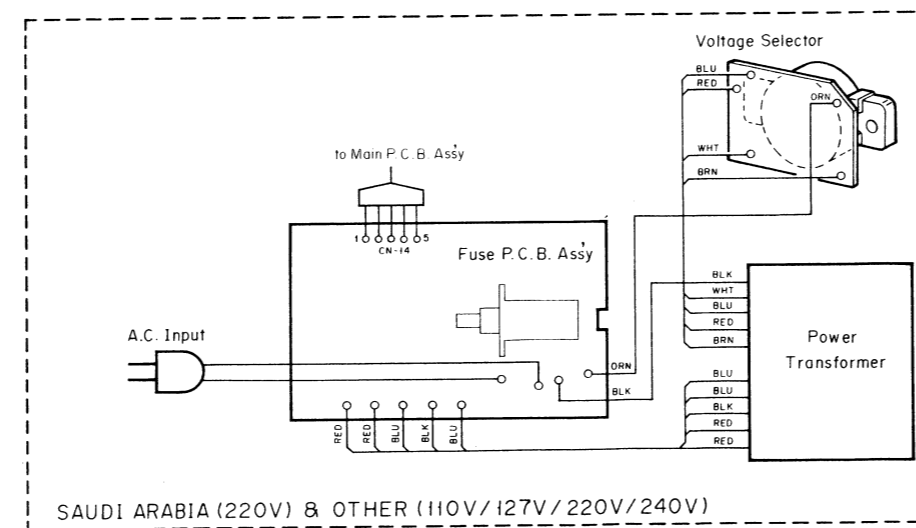
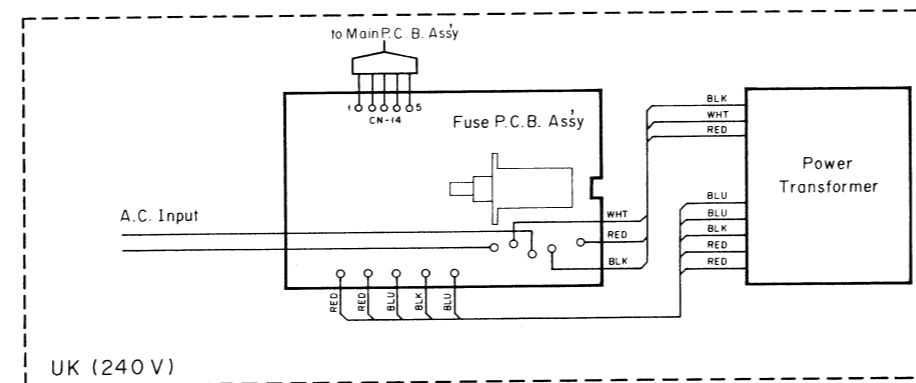
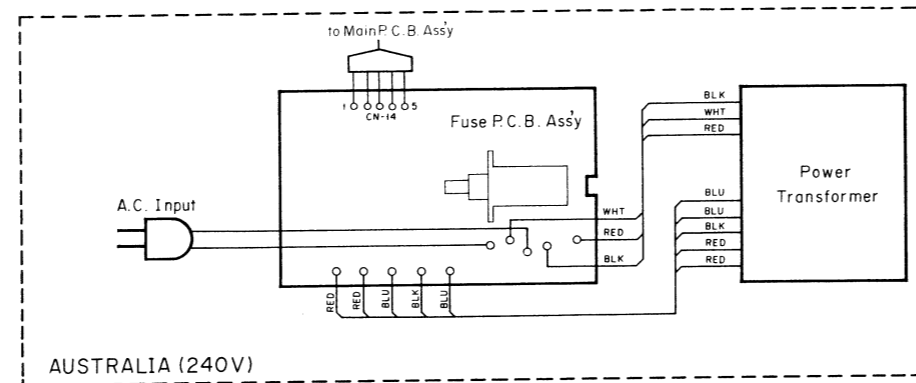
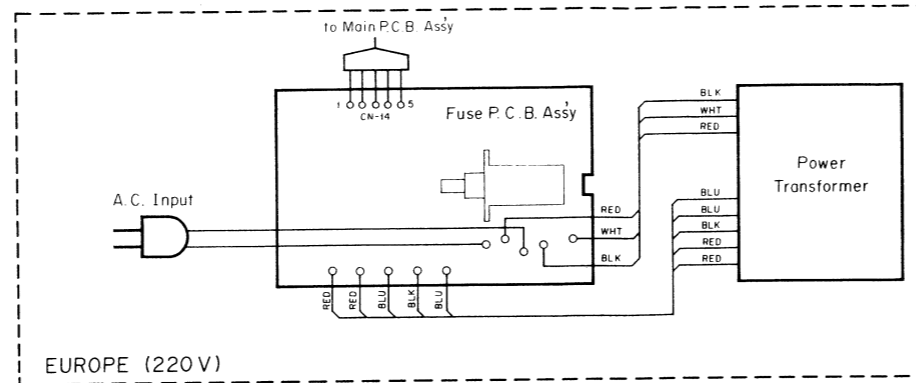

- Notes: 1. Table of wire colors
 BRN - Brown BLU - Blue
 RED - Red VIO - Violet
 ORN - Orange GRY - Gray
 YEL - Yellow WHT - White
 GRN - Green BLK - Black
2. Component side view of the P.C.B. is illustrated unless otherwise specified.
3. Wire tube color is shown in ().

Fig. 10

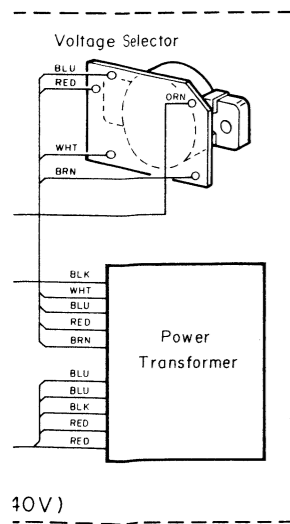
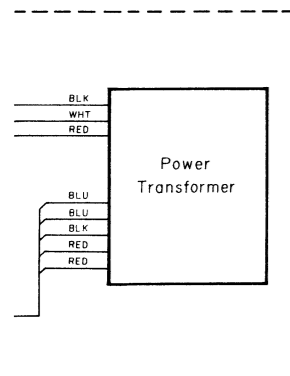
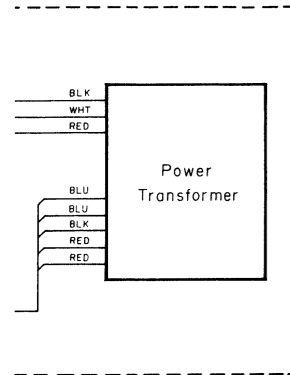
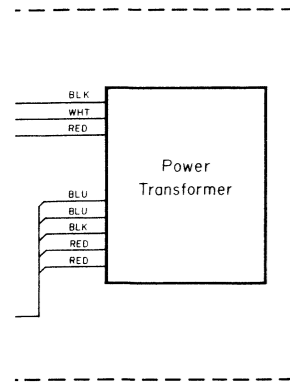

10V)

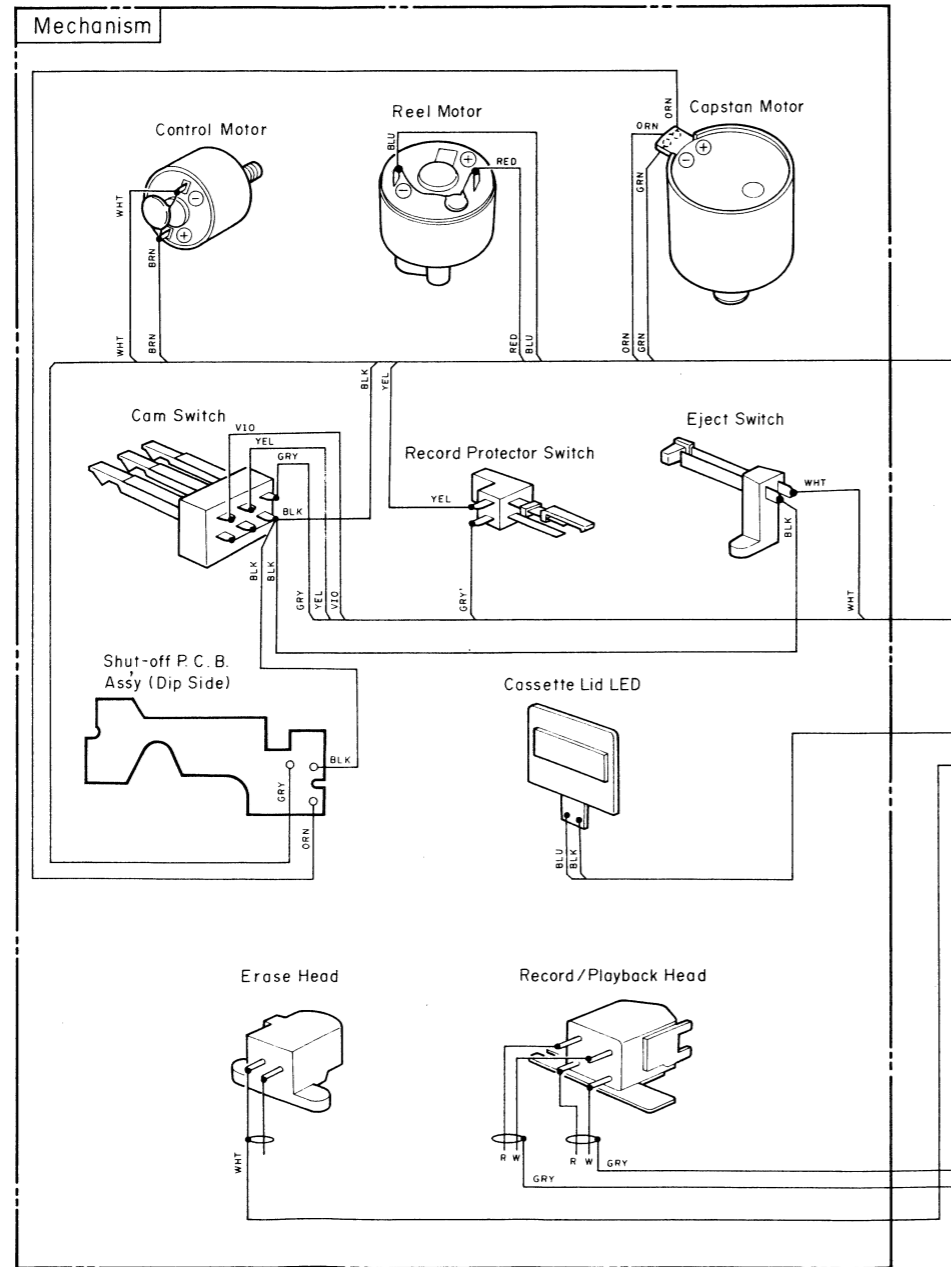
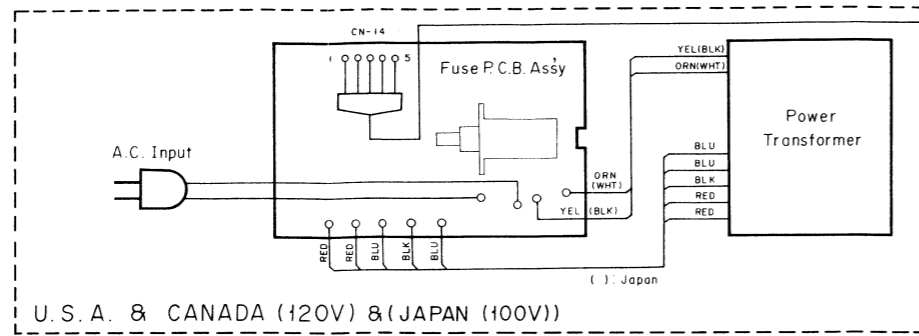
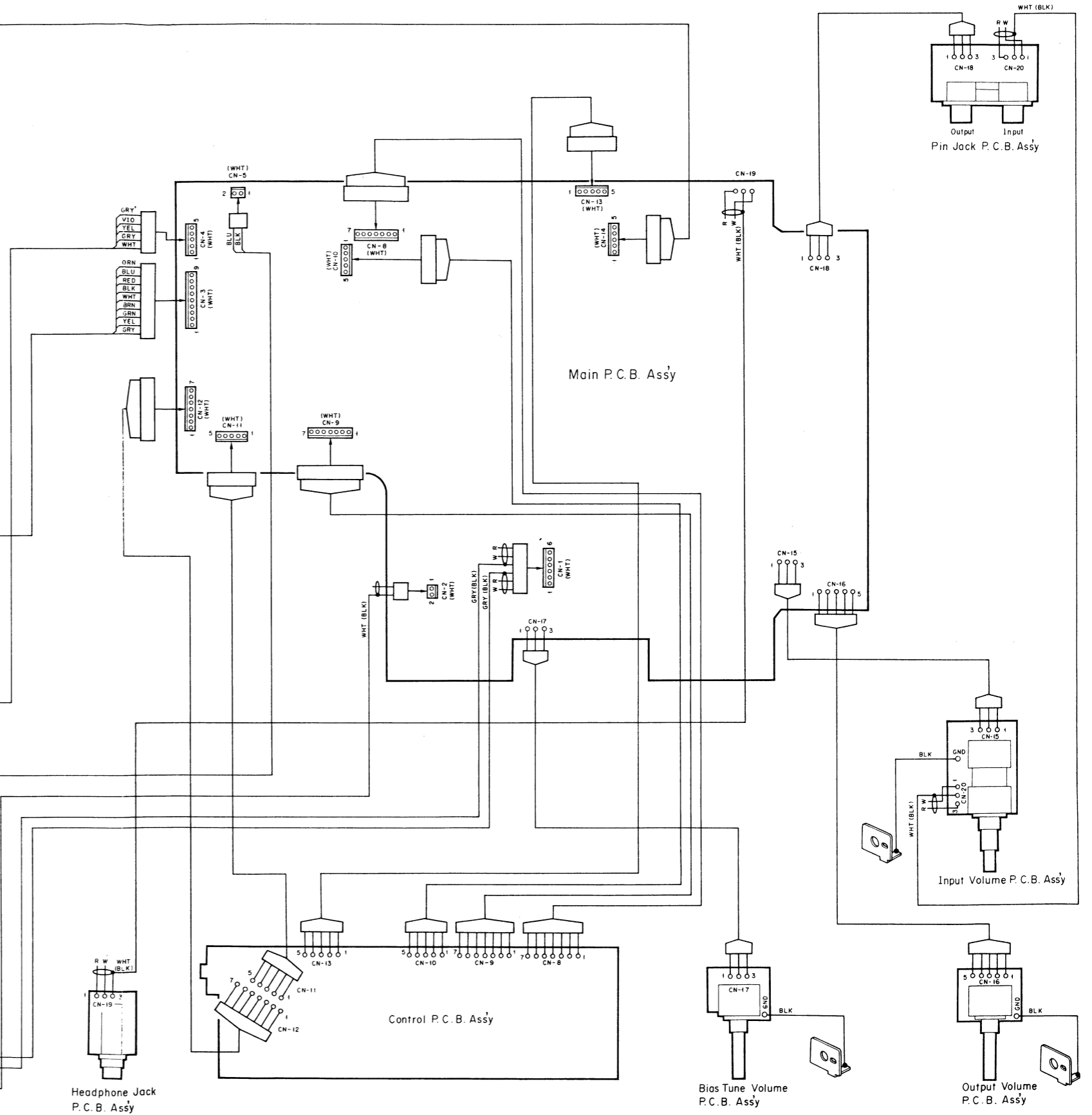

Fig. 10



11. BLOCK DIAGRAMS

11.1. Amplifier Section

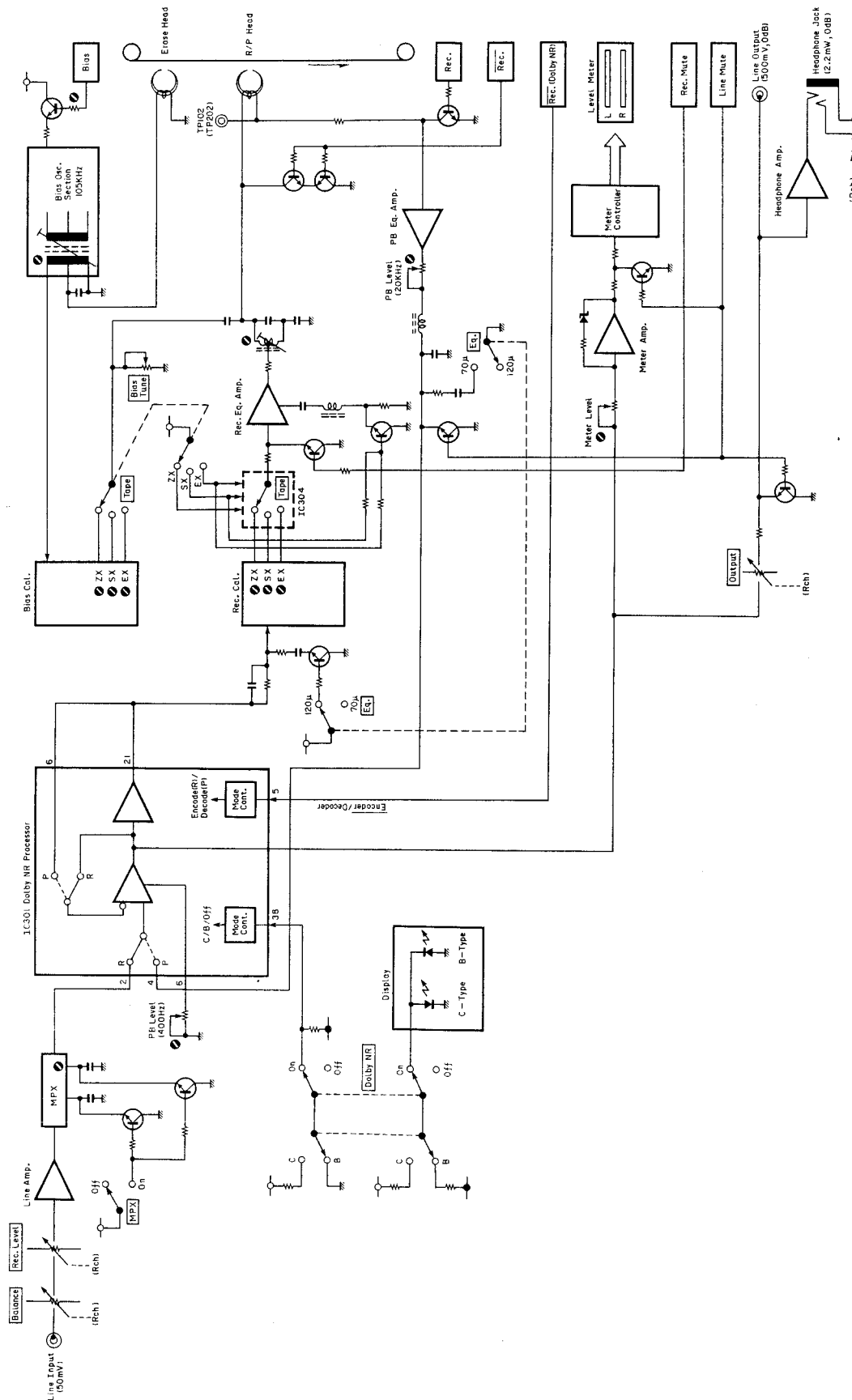

Fig. 11.1

11.2. Mechanism Control Section

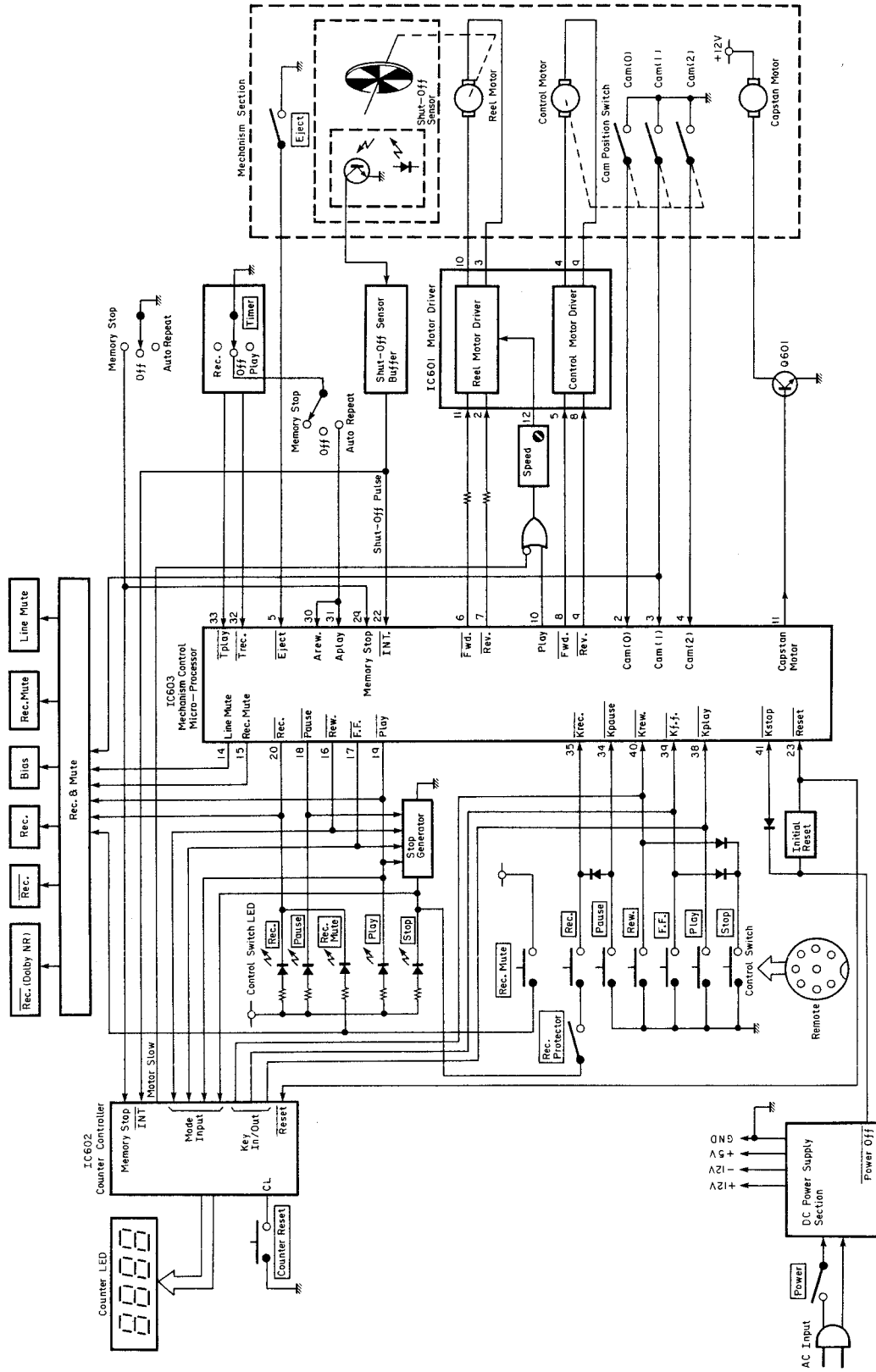

Fig. 11.2

12. TIMING CHARTS AND EQ. AMP. FREQUENCY RESPONSE

12.1. Timing Charts

(1) Overall Timing Chart

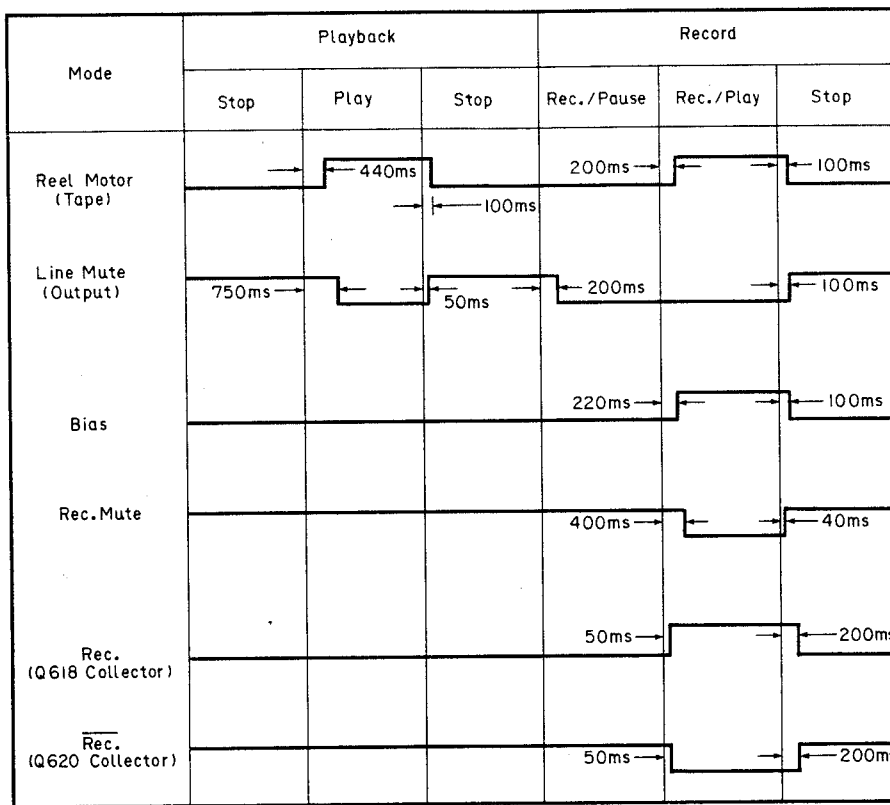

Fig. 12.1.1

(2) Mechanism Control Timing Chart

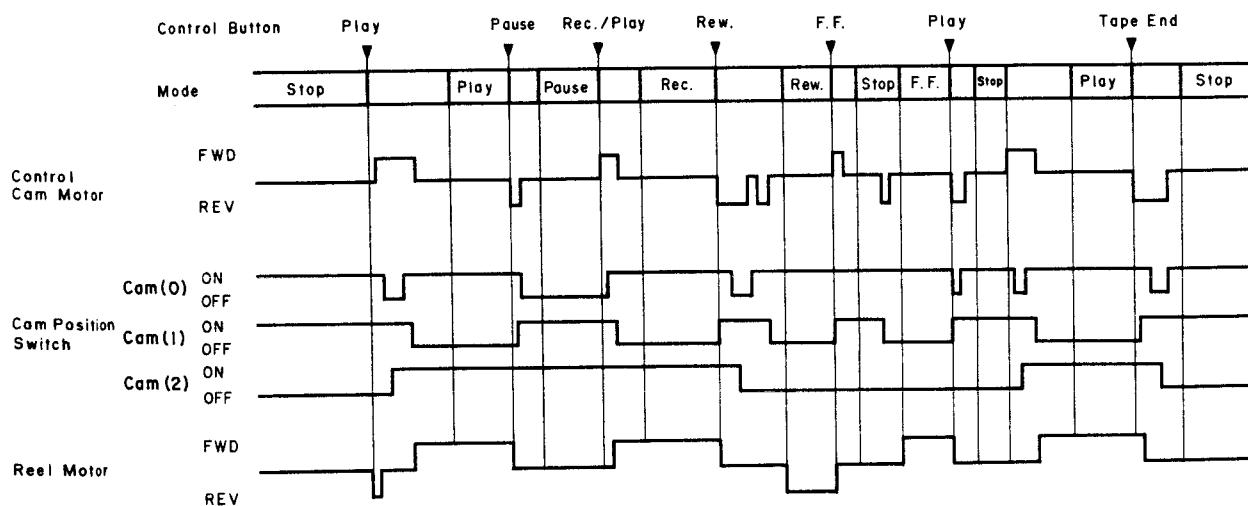

Fig. 12.1.2

12.2. Eq. Amp. Frequency Response
 (1) Playback Frequency Response

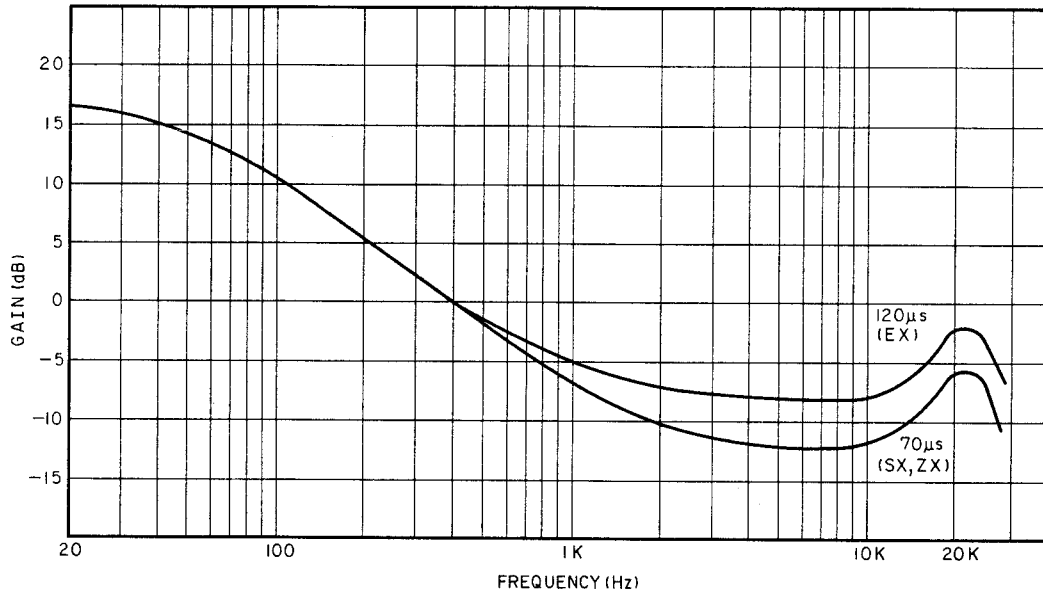

Fig. 12.2.1

(2) Record Current Frequency Response

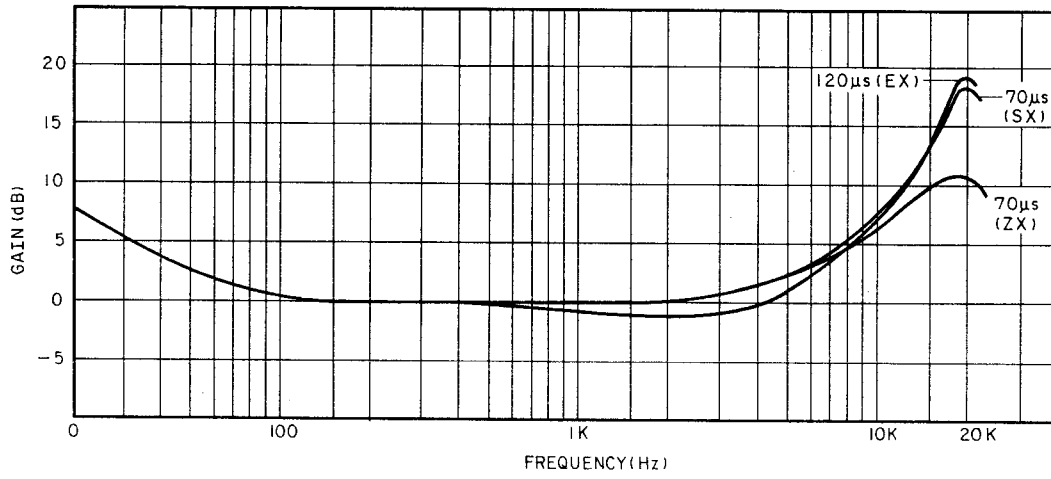

Fig. 12.2.2

13. SPECIFICATIONS

Track Configuration	4 tracks/2-channel stereo
Heads	2 (erase head x 1, record/playback head x 1)
Motors	DC servo motor (capstan drive) x 1 DC motor (reel drive x 1, cam drive x 1)
Power Source	120, 220, 240 or 110/127/220/240 V AC, 50/60 Hz (According to country of sale)
Power Consumption	30 W max.
Tape Speed	1-7/8 ips (4.8 cm/sec.) $\pm 0.5\%$
Wow and Flutter	Less than 0.11% WTD Peak Less than 0.06% WTD RMS
Frequency Response	20 Hz—20,000 Hz ± 3 dB (recording level -20 dB, ZX [Type IV], SX [Type II], EXII [Type I] tape)
Signal to Noise Ratio	Dolby C-Type NR on $<70 \mu\text{s}$, ZX [Type IV] tape Better than 70 dB (400 Hz, 3% THD, IHF A-WTD RMS) Dolby B-Type NR on $<70 \mu\text{s}$, ZX [Type IV] tape Better than 64 dB (400 Hz, 3% THD, IHF A-WTD RMS)
Total Harmonic Distortion	Less than 1.0% (400 Hz, 0 dB, ZX [Type IV], SX [Type II], EXII [Type I] tape)
Erasure	Better than 60 dB (100 Hz, +10 dB)
Separation	Better than 36 dB (1 kHz, 0 dB)
Crosstalk	Better than 60 dB (1 kHz, 0 dB)
Bias Frequency	105 kHz
Input (Line)	50 mV/30k ohms
Output (Line)	0.5 V (400 Hz, 0 dB, output level control at max.) 2.2k ohms
(Headphones)	2.2 mW into 8 ohms (400 Hz, 0 dB, output level control at max.)
Fast-Wind Time	Approx. 80 seconds (with C-60 cassette)
Dimensions	430 (W) x 100 (H) x 265 (D) mm 16-15/16 (W) x 3-15/16 (H) x 10-7/16 (D) inches
Approximate Weight	5.4 kg, 11 lbs. 14 oz.

- Specifications and design are subject to change for further improvement without notice.
- Noise Reduction System manufactured under license from Dolby Laboratories Licensing Corporation.
- The word "DOLBY" and the Double-D-Symbol are trademarks of Dolby Laboratories Licensing Corporation.

Service Manual

Nakamichi

CR-2, CR-2A, CR-2E, CR-20

Nakamichi Corporation/Tokyo Office
Nakamichi America Corporation
Nakamichi Canada
Nakamichi GmbH

Shinjuku Daiichi Seimei Bldg., 2-7-1 Nishishinjuku, Shinjuku-ku, Tokyo 163 Phone: (03) 342-4461 Telex: 2324721 (NA,KAM J)
19701 South Vermont Ave., Torrance, CA 90502 Phone: (213) 538-8150
276 South West, Marine Drive, Vancouver, B.C. V5X 2R4 Phone: (604) 324-7535
Stephanienstrasse 6, 4000 Düsseldorf 1 Phone: (0211) 359036