

CR-3, CR-3A,
CR-3E, CR-30
SQ



Nakamichi

Service Manual

Nakamichi

CR-3

CR-3A

CR-3E

CR-30

Discrete Head Cassette Deck

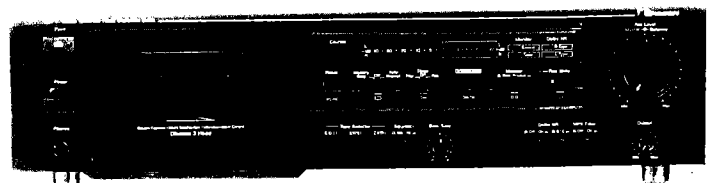

CONTENTS

1.	General	1
2.	Removal Procedures	3
2. 1.	Top Cover Ass'y and Bottom Cover Ass'y	3
2. 2.	Cassette Case Cover Ass'y	3
2. 3.	Mechanism Ass'y	3
2. 4.	Monitor Switch Joint	3
2. 5.	Pin Jack P.C.B. Ass'y, Power Supply P.C.B. Ass'y, and Main P.C.B. Ass'y	3
2. 6.	Front Panel	4
2. 7.	Bias Tune Volume P.C.B. Ass'y	4
2. 8.	Control P.C.B. Ass'y	4
2. 9.	Head Mount Base	5
2. 10.	Power Switch Joint	5
3.	Test Tapes and Gauges	5
4.	Mechanical Adjustments	6
4. 1.	Record Head and Playback Head Tilt Adjustment	6
4. 2.	Head Base Stroke Check	6
4. 3.	Erase Head Stroke Adjustment and Tape Guide Height Check	6
4. 4.	Erase Head Height and Tilt Adjustment	7
4. 5.	Playback Head and Record Head Height Adjustment and Azimuth Alignment	7
4. 6.	Pressure Adjustment of Take-up Pressure Roller	8
4. 7.	Tape Travelling Check	8
4. 8.	Eject Damper Adjustment	8
4. 9.	Reel Motor Speed Adjustment in Play Mode	8
4. 10.	Tape Speed Adjustment	8
4. 11.	Lubrication	8
5.	Parts Location for Electrical Adjustment	9
6.	Electrical Adjustments	10
7.	Mechanism Ass'y and Parts List	14
7. 1.	Synthesis	14
7. 2.	Chassis Ass'y (A01)	15
7. 3.	Bottom Cover Ass'y (A02)	16
7. 4.	Mechanism Ass'y (B01)	18
7. 5.	Front Escutcheon Ass'y (B02)	18
8.	Mounting Diagrams and Parts List	19
8. 1.	Fuse P.C.B. Ass'y	19
8. 2.	Pin Jack P.C.B. Ass'y	19
8. 3.	Input Volume P.C.B. Ass'y	19
8. 4.	Output Volume P.C.B. Ass'y	19
8. 5.	Bias Tune Volume P.C.B. Ass'y	19
8. 6.	Headphone P.C.B. Ass'y	19
8. 7.	Shut-off P.C.B. Ass'y	19
8. 8.	Power Supply P.C.B. Ass'y	20
8. 9.	Control P.C.B. Ass'y	20
8. 10.	Main P.C.B. Ass'y	21
9.	Schematic Diagram	23
9. 1.	IC Block Diagrams	23
9. 2.	Schematic Diagram	28
10.	Wiring Diagram	29
11.	Block Diagrams	30
11. 1.	Amplifier Section	30
11. 2.	Mechanism Control Section	31
12.	Timing Charts and Eq. Amp. Frequency Response	32
12. 1.	Timing Charts	32
12. 2.	Eq. Amp. Frequency Response	33
13.	Specifications	34

1. GENERAL

1.1. Voltage Selector

Voltage selector is installed on the rear panel for Other version of the Nakamichi CR-3.
This voltage selector can select 110, 127, 220, or 240 V at customer's disposal.

1.2. Package Ass'y and Accessory Ass'y

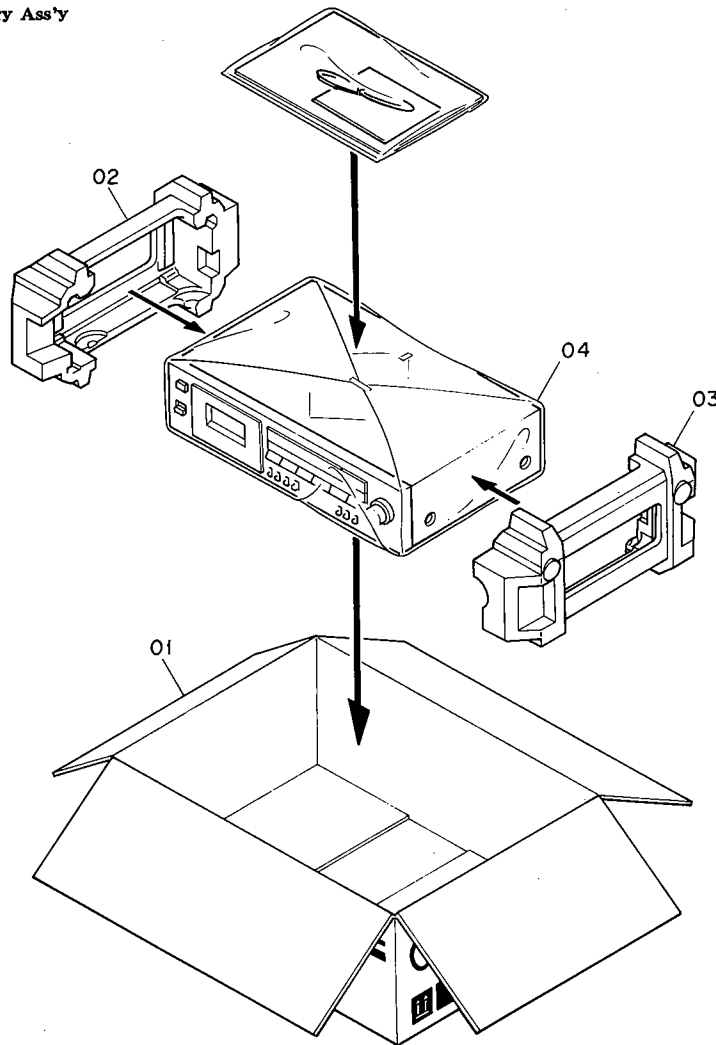

Fig. 1

Schematic Ref. No.	Part No.	Description	Q'ty	Schematic Ref. No.	Part No.	Description	Q'ty
		Package Ass'y				Accessory Ass'y	
01	OF04065A	Carton Box (CR-3)	1		0D03092B	Poly-Bag	1
	OF04066A	Carton Box (CR-3A)	1		0D04449A	Important Notice (CR-3, CR-3E & CR-30)	1
	OF04067A	Carton Box (CR-3E)	1		0D04810A	Important Notice (CR-3A)	1
	OF04101A	Carton Box (CR-30)	1		0D04766A	General Catalogue (CR-3A)	1
02	OF04087C	Packing L	1		0D04783B	Owner's Manual (English/ German/French)	1
03	OF04088C	Packing R	1		0D04784B	Owner's Manual (Japanese)	1
04	OF03684A	Poly-Sheet S	1		0D04786B	Price Card (CR-30)	1
	OD04046A	Warranty Card (CR-30)	1		0D04796A	Tape Catalogue (CR-3A)	1
	OD04047A	User's Pack (CR-30)	1		0D04795A	Tape Catalogue (CR-30)	1
	OM03457A	Voltage Label 240V (CR-3 (Australia) & CR-3E (UK))	2		0D04797A	Warranty Card (CR-3A)	1
	OM05101A	Voltage Label (CR-3 (Saudi Arabia))	2		0D04812A	Tape Supplement	1
	OM05085A	Point of Sale Label (CR-30)	1		OM03844B	Power Cord Label (CR-3E (UK))	1
	OM05056A	Serial No. Label (CR-3, CR-3E & CR-30)	1		DA04121A	Pin Cord Ass'y	1
	OM05069A	Serial No. Label (CR-3A)	2				
	OM05106A	UL Label (CR-3A)	1				
	OM05105A	LA Label (CR-3A)	1				
	OM05107A	Canada Label (CR-3A)	1				
	OM05108A	UL/Canada Label (CR-3A)	1				
	OM05102A	Shipping Label Los (CR-3A)	1				
	OM05103A	Shipping Label VAN (CR-3A)	1				

2. REMOVAL PROCEDURES

2.1. Top Cover Ass'y and Bottom Cover Ass'y

Refer to Fig. 2.1.

- (1) Loosen F01 and remove F02 (Top Cover Ass'y).
- (2) Loosen F03 and remove F04 (Bottom Cover Ass'y).

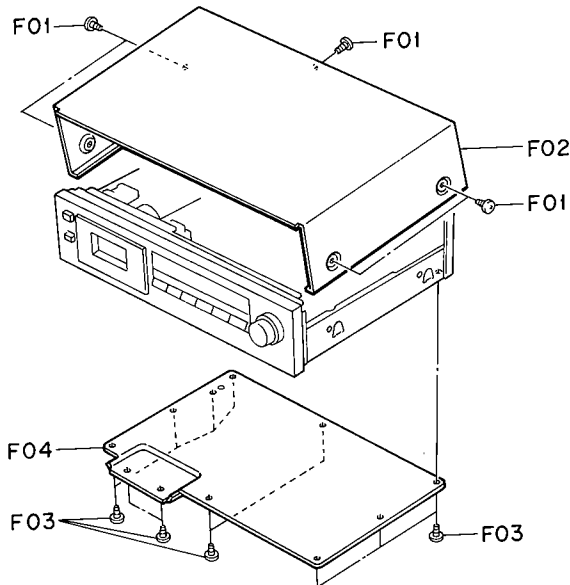

Fig. 2.1

2.2. Cassette Case Cover Ass'y

Refer to Fig. 2.2.

- (1) Press F01 (Eject Button) to open F02 (Cassette Case Cover Ass'y).
- (2) Pull F02 (Cassette Case Cover Ass'y) upward.

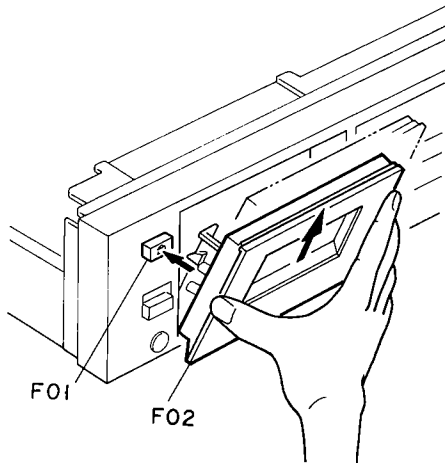

Fig. 2.2

2.3. Mechanism Ass'y

Refer to Fig. 2.3.

- (1) Remove the Top Cover Ass'y and the Bottom Cover Ass'y referring to item 2.1.
- (2) Remove the Cassette Case Cover Ass'y referring to item 2.2.
- (3) Loosen F01, F02 and F03, remove F04, and disassemble F05 (Mechanism Ass'y).

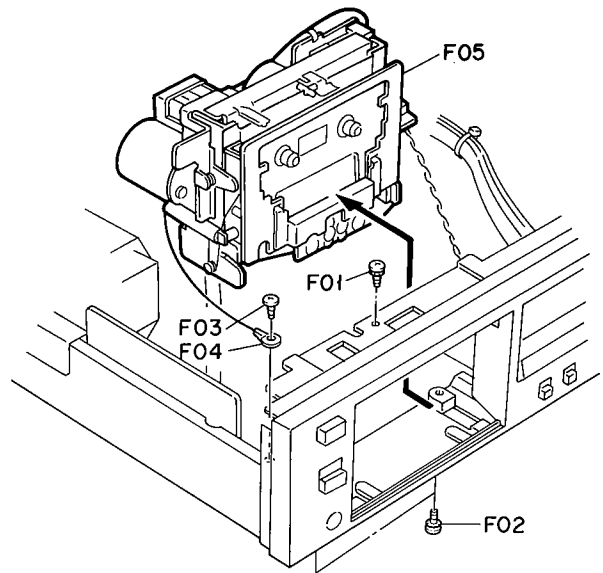

Fig. 2.3

2.4. Monitor Switch Joint

Refer to Fig. 2.4.

- (1) Remove the Top Cover Ass'y and the Bottom Cover Ass'y referring to item 2.1.
- (2) With pushing F01 (Monitor Switch Joint) in the direction of the arrow A, pull F01 (Monitor Switch Joint) in the direction of the arrow B to remove it.

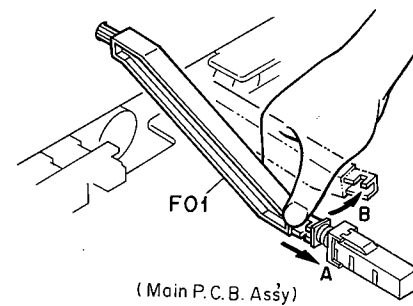

Fig. 2.4

2.5. Pin Jack P.C.B. Ass'y, Power Supply P.C.B. Ass'y, and Main P.C.B. Ass'y

Refer to Fig. 2.5.

- (1) Remove the Top Cover Ass'y and the Bottom Cover Ass'y referring to item 2.1.
- (2) Remove the Monitor Switch Joint referring to item 2.4.
- (3) Loosen F01 and remove F02 (Pin Jack P.C.B. Ass'y).
- (4) Loosen F03 and remove F04 (Power Supply P.C.B. Ass'y).
- (5) Push F05 (Hole Plug) with the top of screwdriver to remove it.
- (6) Loosen F06 and lift F07 (Main P.C.B. Ass'y).

Note: When installing the Main P.C.B. Ass'y, to facilitate installation, place the Main P.C.B. Ass'y so that the tops of switches on the Main P.C.B. Ass'y come in contact with the ends of push buttons as shown in Fig. 2.6.

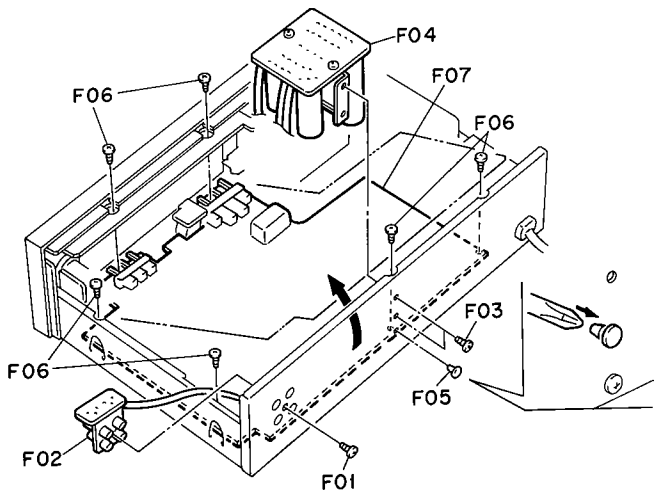

Fig. 2.5

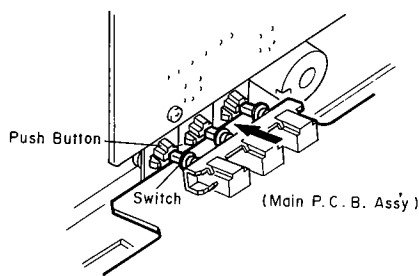

Fig. 2.6

2.6. Front Panel
Refer to Fig. 2.7.

- (1) Remove the Top Cover Ass'y and the Bottom Cover Ass'y referring to item 2.1.
- (2) Remove the Cassette Case Cover Ass'y referring to item 2.2.
- (3) Pull out F01, F02 and F03, and loosen F04 and F05.
- (4) With pushing claws by hand as shown in the figure, remove F06 (Front Panel).

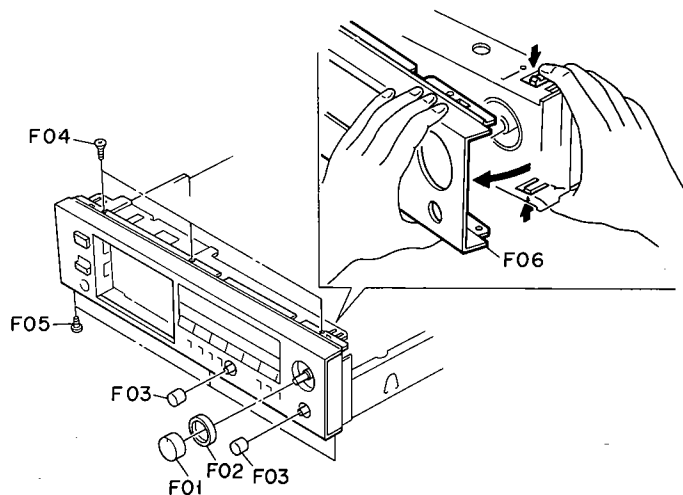

Fig. 2.7

2.7. Bias Tune Volume P.C.B. Ass'y

Refer to Fig. 2.8.

- (1) Remove the Top Cover Ass'y and the Bottom Cover Ass'y referring to item 2.1.
- (2) Remove the Monitor Switch Joint referring to item 2.4.
- (3) Remove the Main P.C.B. Ass'y referring to item 2.5.
- (4) Remove the Front Panel referring to item 2.6.
- (5) Loosen F01 and F02 with a special nut driver or with pliers, and remove F03 (Bias Tune Volume P.C.B. Ass'y).

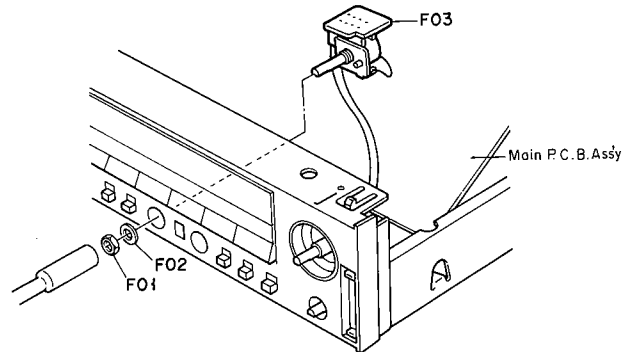

Fig. 2.8

2.8. Control P.C.B. Ass'y

Refer to Fig. 2.9.

- (1) Remove the Top Cover Ass'y and the Bottom Cover Ass'y referring to item 2.1.
- (2) Remove the Mechanism Ass'y referring to item 2.3.
- (3) Remove the Monitor Switch Joint referring to item 2.4.
- (4) Remove the Front Panel referring to item 2.6.
- (5) Loosen F01 and F02 with a special nut driver or with pliers to set F03 (Bias Tune Volume P.C.B. Ass'y) free.
- (6) With pushing F03 (Bias Tune Volume P.C.B. Ass'y) in the direction of the arrow, loosen F04, unhook F05, and remove F06 (Control P.C.B. Ass'y).

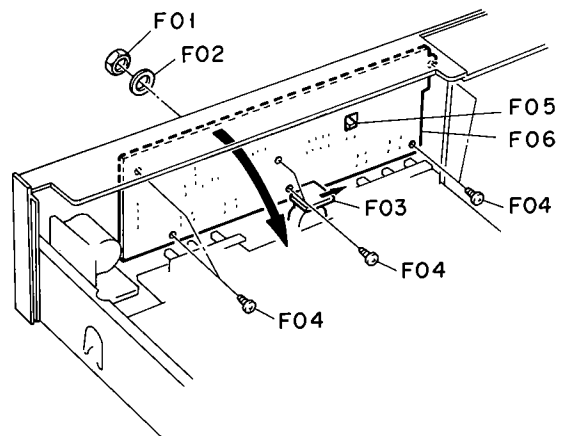

Fig. 2.9

2.9. Head Mount Base Ass'y

Refer to Fig. 2.10.

- (1) Remove the Top Cover Ass'y and the Bottom Cover Ass'y referring to item 2.1.
- (2) Remove the Mechanism Ass'y referring to item 2.3.
- (3) Loosen F01 and remove F02 (Head Mounting Cover).
- (4) Loosen F03, remove F04 and F05, straighten F06 (Wire Clamper), and lift F07 (Head Mount Base Ass'y).

Note: When mounting the Head Mount Base Ass'y, follow the next steps. Refer to Figs. 2.11.1 and 2.11.2.

- (a) Insert the Plate Washer into the groove of the shaft as shown in Fig. 2.11.1.
- (b) Mount F07 (Head Mount Base Ass'y) and fasten F03. Then push the Plate Washer with a blade of screwdriver to set the Plate Washer free. Refer to Fig. 2.11.2.

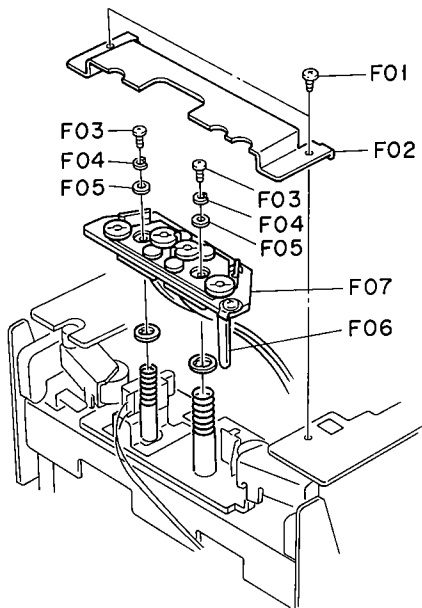

Fig. 2.10

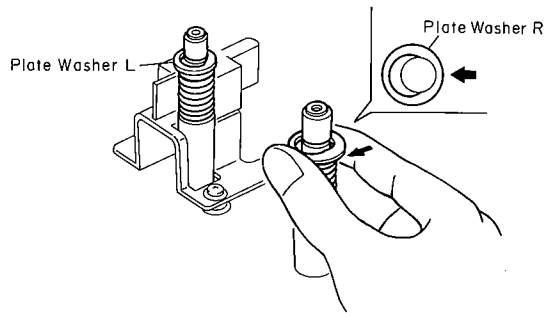

Fig. 2.11.1

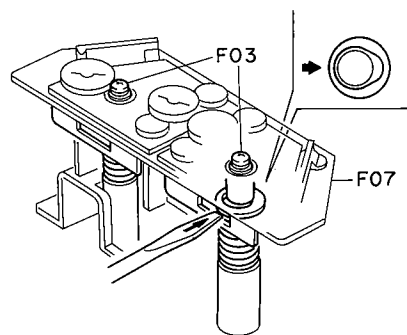

Fig. 2.11.2

2.10. Power Switch Joint

Refer to Fig. 2.12.

- (1) Remove the Top Cover Ass'y referring to item 2.1.
- (2) Pull F01 (Power Switch Joint) upward to remove it.

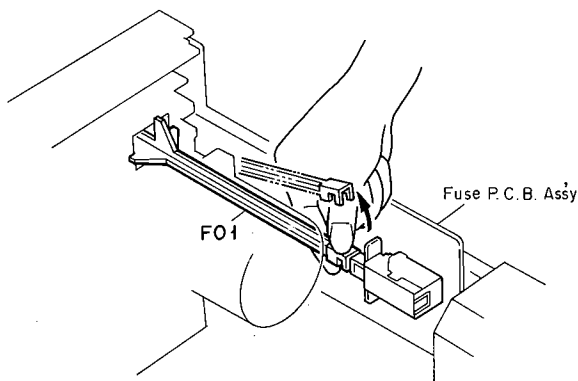

Fig. 2.12

3. TEST TAPES AND GAUGES

- | | |
|---|--|
| <ol style="list-style-type: none"> (1) 400 Hz Level Tape (DA09005B) (2) 1 kHz Track Alignment B Tape (DA09087B) (3) 10 kHz PB Frequency Response Tape (DA09003B) (4) 15 kHz PB Frequency Response Tape (DA09002B) (5) 20 kHz PB Frequency Response Tape (DA09001B) (6) 15 kHz Azimuth Tape (DA09004B) (7) 3 kHz Speed and Wow/Flutter Tape (DA09006C) (8) Tape Travelling Cassette (DA09071A) (9) Reference EXII Tape (DA09111A) (10) Reference SX Tape (DA09110A) (11) Reference ZX Tape (DA09109A) | <ol style="list-style-type: none"> (12) EH Tilt Check Gauge S (DA09088A) (13) Stroke Check Gauge S (DA09090A) (14) Tape Guide Height Check Gauge S (DA09091A) (15) Tilt Check Gauge S (DA09039B) (16) Torque Gauge FWD (DA09082A) |
|---|--|

4. MECHANICAL ADJUSTMENTS

4.1. Record Head and Playback Head Tilt Adjustment

Remove the Cover Plate Ass'y by loosening two screws to gain access to the head block.

Refer to Fig. 4.1.

- (1) Remove the pad lifter from the playback head.
- (2) Load a Tilt Check Gauge S (DA09039B) in the cassette deck.
- (3) Clip the grounding terminal of the Tilt Check Gauge with one end of the cord with clip, and the chassis of the cassette deck with the other end.
- (4) Remove both of the Height Gears.
- (5) Set the cassette deck in Play mode. Check to insure whether the Beacons Playback Head "Upper" or "Lower" and Record Head "Upper" or "Lower" are illuminating. In order not to give damages onto the head surfaces, push both of slide knobs of the Gauge to away from the heads, then return them to the original place to be in contact with record head and playback head surfaces after Play mode is securely locked.
- (6) Beacon Playback Head "Lower" will light on when height adjustment screw (PH) turned counterclockwise but playback Head "Upper" when clockwise. Adjust so that both "Upper" and "Lower" will light on even when you move the slide knob away from the heads and then return it to the original place.
- (7) Same procedures will apply to the Beacons Record Head "Upper" and "Lower", except for the height adjustment screw (RH).
- (8) Set the cassette deck in Stop mode and fit both of the serrated Height Gears. Then set the cassette deck again in Play mode and insure all of the 4 Beacons are illuminating. If not, (4) through (7) will have to be repeated till satisfactory results are obtained.
- (9) Mount the pad lifter on the playback head.

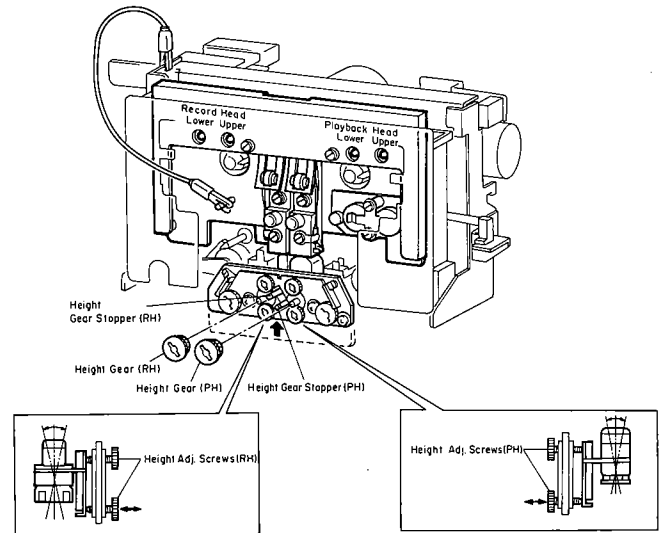

Fig. 4.1

4.2. Head Base Stroke Check

Remove the Cover Plate Ass'y.

Refer to Fig. 4.2.

Note: Before you conduct this adjustment, adjust with a "Tilt Check Gauge S" to insure freedom from tilt on the playback head and record head.

- (1) Load a Stroke Check Gauge S (DA09090A) in the cassette deck.
- (2) Move Record Head Indicator and Playback Head Indicator to the direction of arrow mark "A" with your finger tip and then set the cassette deck in Play mode. Then slowly release the Indicators and insure whether each of the Indicators is in contact with record and playback heads.
- (3) Check to insure whether the line "P" on the Playback Head Indicator meets the central line on the Indicator Plate.
- (4) Check to insure whether the line "P" on the Playback Head Indicator locates between the 2 lines on the Record Head Indicator, thus check can be made on record head stroke.

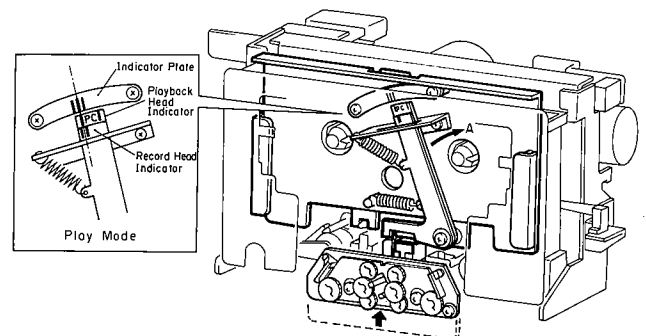

Fig. 4.2

4.3. Erase Head Stroke Adjustment and Tape Guide Height Check

Remove the Cover Plate Ass'y and the Head Mount Base Ass'y. Refer to Fig. 4.3.

- (1) Erase Head Stroke Adjustment
 - (a) Load a Tape Guide Height Check Gauge S (DA09091A) in the cassette deck.
 - (b) Set the cassette deck in Play mode, thus check can be made on erase head stroke through the EH Stroke Indicator.
 - (c) Check to insure whether the erase head surface is aligned with red line on the EH Stroke Indicator. If not, adjust the erase head stroke by loosening screw A that assembles erase head with erase head plate.
 - (d) After completion of adjustment, screw A shall be locked with lock tight paint.
- (2) Supply Tape Guide Height Adjustment
 - (a) Load a Tape Guide Height Check Gauge S (DA09091A) in the cassette deck.
 - (b) Set the cassette deck in Play mode.
 - (c) Slide the Supply Tape Guide Check Bar down against the supply tape guide, and check to insure that the Supply Tape Guide Check Bar is accepted by the supply tape guide. If not, adjust the supply tape guide height by turning screw B.
- (3) Take-up Tape Guide Height Check
 - (a) Load a Tape Guide Height Check Gauge S (DA09091A) in the cassette deck.
 - (b) Set the cassette deck in Play mode.
 - (c) Slide the Take-up Tape Guide Check Bar down against the take-up tape guide, and check to insure that the Take-up Tape Guide Check Bar is accepted by the take-up tape guide.

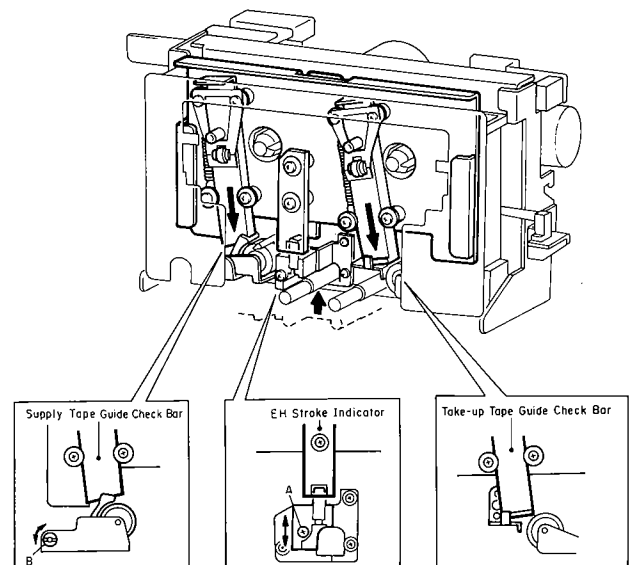

Fig. 4.3

4.4. Erase Head Height and Tilt Adjustment

Refer to Fig. 4.4.

- (1) Remove the Cassette Case Cover Ass'y, Cover Plate Ass'y, and Head Mount Base Ass'y.
- (2) Load an EH Tilt Check Gauge S (DA09088A) in the cassette deck.
- (3) Set the cassette deck in Stop mode.
- (4) Check to insure whether one of the 3 Beacons is illuminating. Look down the mirror and slowly turn the Screw "Height" counterclockwise (or clockwise) so that the two horizontal lines on the mirror will become superposed on the line (in different color) of the erase head, and check to insure whether the first Beacon is illuminating.
- (5) Turn Screw "Tilt" counterclockwise (or clockwise) to light on the second Beacon. Excessive turning will cause the first

Beacon to light off. Adjustments of Screw "Tilt" will therefore be conducted till both of the first and the second Beacons illuminate.

- (6) Turn Screw "Azimuth" counterclockwise (or clockwise) to light on the third Beacon. Excessive turning will cause either the first or the second Beacon to light off, and therefore adjust Screw "Azimuth" until all of the 3 Beacons illuminate.
- (7) Check to insure whether the horizontal line on the mirror corresponds to that on the erase head. If not, (4) through (7) will have to be repeated till satisfactory results are obtained.
- (8) After completion of adjustment, 3 pcs. of screws shall be locked with lock tight paint.

Note: Before use of this gauge, check to insure freedom from dust or dirt, or overflow in the groove of the erase head surface.

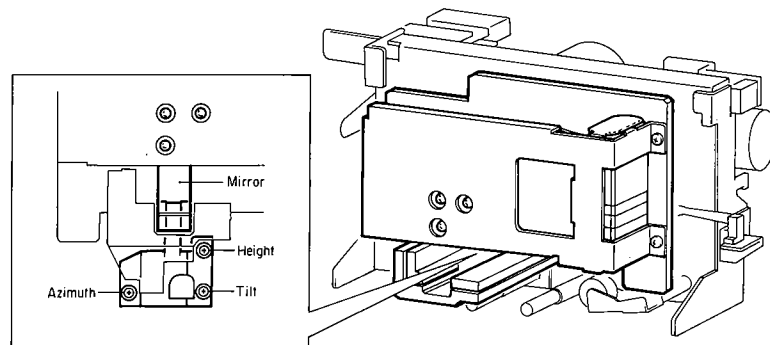

Fig. 4.4

4.5. Playback Head and Record Head Height Adjustment and Azimuth Alignment

Refer to Fig. 4.5.

- (1) Playback Head Height Adjustment and Azimuth Alignment
 - (a) Set the Monitor switch to Tape and connect an AC voltmeter to the Output Jacks.
 - (b) Load a 1 kHz Track Alignment B Tape (DA09087B) and set the cassette deck in Play mode.
 - (c) Turn the PH Height Gear until the outputs of both channels become minimum.
 - (d) Load a 15 kHz Azimuth Tape (DA09004B) and set the cassette deck in Play mode.
 - (e) Turn the PH Azimuth Alignment Screw until the outputs of both channels become maximum.
 - (f) Repeat above steps (b) through (e) two or three times to obtain optimum performance.

(2) Record Head Height Adjustment and Azimuth Alignment

- (a) Set the cassette deck in Stop mode.
- (b) Set the Monitor switch to Tape, Eq. switch to 70 μ s and Tape Selector switch to ZX.
- (c) Load a reference ZX tape and connect an AC voltmeter to Output Jacks.
- (d) Feed in 400 Hz (0 dB) to the Input Jacks.
- (e) Set the cassette deck in Record and Play mode and turn the RH Height Gear until the outputs of both channels become maximum.
- (f) Feed in 15 kHz (-20 dB) to the Input Jacks and turn the RH Azimuth Alignment Screw until the outputs of both channels become maximum.
- (g) Repeat (d) to (f) two or three times to obtain optimum performance.

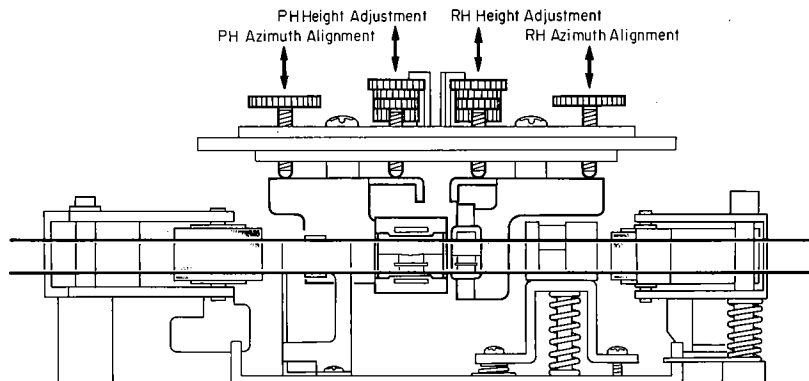

Fig. 4.5

4.6. Pressure Adjustment of Take-up Pressure Roller

Refer to Fig. 4.6.

- (1) Set the cassette deck in Play mode.
- (2) Measure the torque of the Take-up Pressure Roller and check whether the torque is in a range of 320 ± 50 g-cm.
- (3) If torque is out of the range, correct it by changing the installation point of the Pressure Roller Spring.

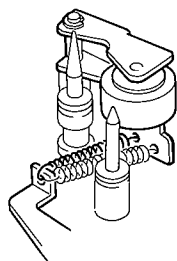

Fig. 4.6

4.7. Tape Travelling Check

Load and play back a Tape Travelling Cassette and check the following:

- (1) Tape is in contact with heads sufficiently.
- (2) Tape waving is small on the heads and pressure rollers.
- (3) Tape is free from waving or slippage from the tape guides.

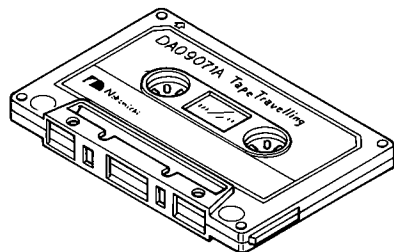

Fig. 4.7

4.8. Eject Damper Adjustment

Refer to Fig. 4.8. Load a cassette tape, and with opening the Cassette Case by pressing the Eject button and closing it by hand, adjust the speed of damper action by the Adjustment Screw.

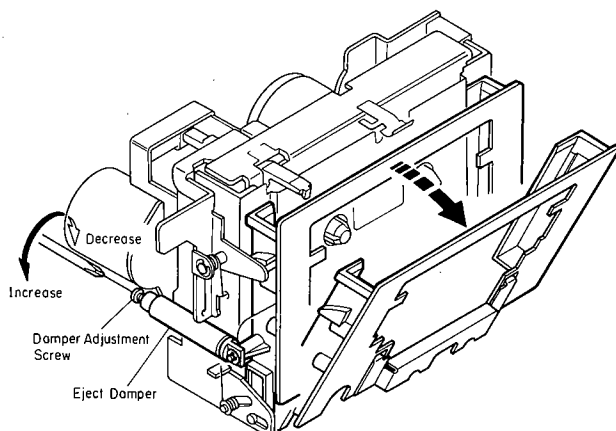

Fig. 4.8

4.9. Reel Motor Speed Adjustment in Play Mode

- (1) To warm-up the cassette deck, load a C-60 cassette tape and set the cassette deck in Play mode.
- (2) After more than four minutes, load a Torque Gauge FWD (DA09082A) and set the cassette deck in Play mode.
- (3) Adjust VR601 on the Main P.C.B. Ass'y to obtain exactly 50 g-cm on the torque gauge.

4.10. Tape Speed Adjustment

Refer to Fig. 4.9.

- (1) Connect a frequency counter to the Output Jacks.
- (2) Load a 3 kHz Speed and Wow/Flutter Tape (DA09006C) and play it back.
- (3) Adjust the Tape Speed Adjustment Volume incorporated in the Capstan Motor to obtain 3,000 Hz on the frequency counter.

CCW: Motor drives slowly.

CW: Motor drives fast.

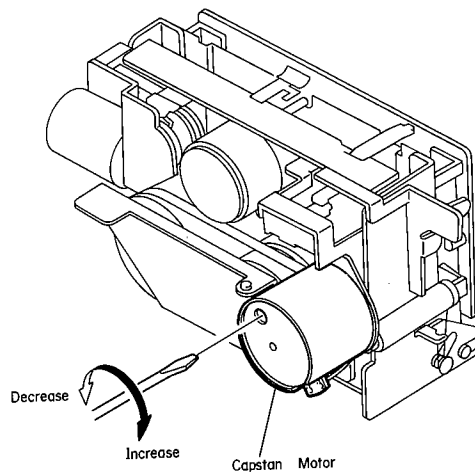



Fig. 4.9

4.11. Lubrication

The tape transport is of a lubrication-free type mechanism. When the following parts are replaced, apply the specified lubricant.

- (1) Molykote  Grease (X5-6020)
Cam Motor Pulley
Thrust portion on the Capstan Shaft
- (2) FLOIL GB-TS-1
Washer between Reel Hub Ass'y and Back Tension Spring
- (3) Diamond Oil (EP-56)
Reel Hub Shaft
- (4) Anderol 456
Capstan Shaft

Note: We suggest that you use the above specified lubricant or equivalent type.

The company dealing in the above lubricant is as follows:

- (a) Molykote  Grease (X5-6020)
Dowcorning Co., Ltd., 1-15-1 Nishishinbashi, Minato-ku, Tokyo, Japan
- (b) FLOIL GB-TS-1
Kanto Chemicals Co., Ltd., 2-7 Kanda Sakuma-cho, Chiyoda-ku, Tokyo, Japan
- (c) Diamond Oil (EP-56)
Mitsubishi Oil Co., Ltd., 1-2-4 Toranomom, Minato-ku, Tokyo, Japan
- (d) Anderol 456
Toyo Kokusai Oil Co., Ltd., 3-3-5 Hatchobori, Chuo-ku, Tokyo, Japan

5. PARTS LOCATION FOR ELECTRICAL ADJUSTMENT

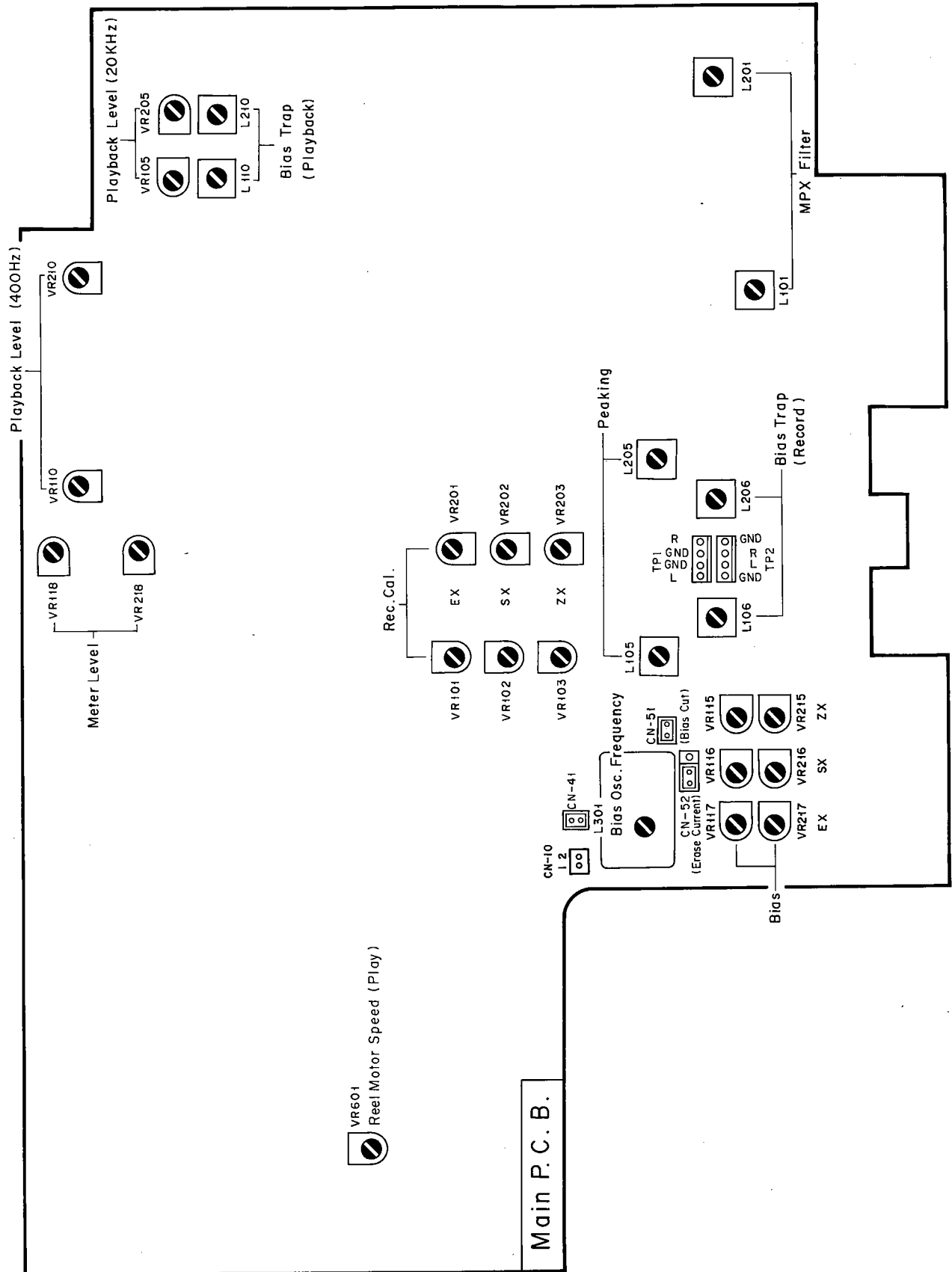
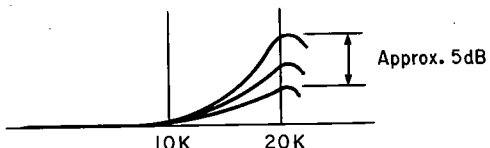
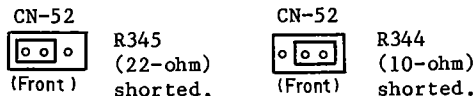

Fig. 5

6. ELECTRICAL ADJUSTMENTS

STEP	ITEM	SIGNAL SOURCE	OUTPUT CONNECTION	MODE	ADJUSTMENT	REMARKS
1	Preliminary Step			Output Level - Max. Balance - Center Bias Tune - Center Monitor - Tape Eq. - 70 μ s Tape - ZX MPX Filter - OFF Dolby NR - OFF		Set the CR-3/3A/3E/30 as shown in MODE.
2	Reel Motor Speed Adjustment (Play)	Torque Guage FWD (DA09082A)		Playback	Main VR601	Adjust VR601 to obtain 50 g-cm on the Torque Gauge.
3	Tape speed Adjustment	3 kHz Speed and Wow/Flutter Tape (DA09006C)	Frequency Counter to Output Jacks	Playback Monitor - Tape Eq. - 120 μ s	Tape Speed Adj. Volume (Capstan Motor)	Adjust the volume incorporated in the Capstan Motor Ass'y to obtain 3 kHz \pm 15 Hz on the frequency counter.
4	Meter Level Calibration	400 Hz to Input Jacks	AC Voltmeter to Output Jacks	Monitor - Source	Main P.C.B. VR118 VR218	1. Feed in 400 Hz and adjust the Input Level control to obtain 500 mV -2 dB on the AC voltmeter. 2. Adjust VR118 (VR218) so that the 0 dB segment on the level meter starts illuminating.
5	MPX Filter Adjustment	19 kHz \pm 100 Hz to Input Jacks	AC Voltmeter to Output Jacks	Monitor - Source MPX - OFF/ON	Main P.C.B. L101 L201	1. Adjust the Input Level control to obtain 500 mV (0 dB) on the AC voltmeter. 2. Set the MPX Filter switch to ON and adjust L101 (L201) to obtain minimum reading on the AC voltmeter. (The minimum reading will be less than -30 dB.)
6	Playback Head Track Alignment	1 kHz Track Alignment Tape (DA09087A)	AC Voltmeter to Output Jacks	Playback Monitor - Type Eq. - 70 μ s Dolby NR - OFF	PH Height Gear	Adjust the PH Height Gear to obtain the minimum readings on the AC voltmeter for both channels. Refer to "Playback Head Height Adjustment" in item 4.5.
7	Playback Head Azimuth Alignment	15 kHz Azimuth Tape (DA09004B)	AC Voltmeter to Output Jacks	Same as above	Playback Head Azimuth Alignment Screw	Adjust the Playback Head Azimuth Alignment Screw to obtain maximum readings on the AC voltmeter for both channels. Refer to "Playback Head Height Adjustment and Azimuth Alignment" in item 4.5. Note: Repeat Steps 6 and 7 two or three times to obtain optimum performance.

STEP	ITEM	SIGNAL SOURCE	OUTPUT CONNECTION	MODE	ADJUSTMENT	REMARKS
8	Playback Level Calibration	400Hz Level Tape (DA09005B)	AC Voltmeter to Output Jacks	Playback Monitor - Type Eq. - 70 μ s Dolby NR - OFF	Main P.C.B. VR110 VR210	Adjust VR110 (VR210) to obtain 500 mV on the AC voltmeter.
9	Playback Frequency Response Adjustment	400Hz Level Tape (DA09005B) 10 kHz PB Frequency Response Tape (DA09003B) 15 kHz PB Frequency Response Tape (DA09002B) 20 kHz PB Frequency Response Tape (DA09001B)	AC Voltmeter to Output Jacks	Same as above	Main P.C.B. VR105 VR205	<ol style="list-style-type: none"> Load a 400 Hz level tape, play it back, and read the playback level on the AC voltmeter. Load 10 kHz, 15 kHz and 20 kHz PB frequency response tapes and adjust the playback head azimuth to obtain maximum levels on the AC voltmeter with each tape. Check that the playback levels are as follows with respect to the level for 400 Hz level tape. <ul style="list-style-type: none"> 10 kHz: -20 dB -2 dB to +2 dB 15 kHz: -20 dB -2 dB to +3 dB 20 kHz: -20 dB -2 dB to +4 dB If the levels are out of the ranges, play back the 20 kHz PB frequency response tape and adjust VR105 (VR205) to obtain -20 dB +1.0 dB. VR105 (VR205) compensates the playback frequency response at 20 kHz as shown below: <div style="text-align: center;">  <p>Approx. 5dB</p> </div>
10	Bias Oscillation Frequency and Erase Current Adjustment	None	AC Voltmeter across the additional 0.1 ohm resistor and Frequency Counter between terminals 1 and 2 of CN-10 on Main P.C.B.	Record, Playback Monitor - Source Tape - ZX Eq. - 70 μ s Dolby NR - OFF	Main P.C.B. L301 R344 R345	<ol style="list-style-type: none"> Connect an additional 0.1 ohm resistor in series to the Erase Head and connect the AC voltmeter across the resistor. Record and playback a reference ZX tape. Adjust L301 to obtain 105 kHz on the frequency counter. Check the erase current by the AC voltmeter. Erase current will be within the range of 310 mA to 400 mA (typically approx. 350 mA). If erase current is less than 310 mA, plug the 2P-receptacle into CN-52 as shown below to short-circuit either R344 or R345. <div style="text-align: center;">  <p>CN-52 R345 (22-ohm) (Front) shorted. CN-52 R344 (10-ohm) (Front) shorted.</p> </div> After completion of the erase current adjustment, re-check the bias oscillation frequency. Remove the additional 0.1 ohm resistor.

STEP	ITEM	SIGNAL SOURCE	OUTPUT CONNECTION	MODE	ADJUSTMENT	REMARKS
11	Record Amplifier Equalizer Adjustment	23 kHz (-20 dB) to Input Jacks	AC Voltmeter between L and GND (R and GND) of TP2 on Main P.C.B.	Record, Playback Monitor - Source Tape - ZX Eq. - 70 μ s Dolby NR - OFF	Main P.C.B. L105 L205	1. Remove the 2P-receptacle from CN-51 to stop the bias oscillation. 2. Adjust L105 (L205) to obtain approx. 16 dB at 23 kHz on the AC voltmeter. 3. Plug the 2P-receptacle into CN-51.
12	Bias Trap Adjustment (Record Amp.)	Remove input signals	AC Voltmeter between L and GND (R and GND) of TP1 on Main P.C.B.	Same as above	Main P.C.B. L106 L206	Adjust L106 (L206) to obtain minimum reading on the AC voltmeter.
13	Record Head Height Adjustment	400 Hz (0 dB) to Input Jacks	AC Voltmeter to Output Jacks	Record, Playback Monitor - Tape Tape - SX Eq. - 70 μ s Dolby NR - OFF	RH Height Gear	1. Load a reference SX tape, and record and play it back. 2. Adjust the RH Height Gear to obtain maximum readings for both channels on the AC voltmeter. Refer to "Record Head Height Adjustment and Azimuth Alignment" in item 4.5.
14	Record Head Azimuth Alignment	15 kHz (-20 dB) to Input Jacks	AC Voltmeter to Output Jacks	Same as above	Record Head Azimuth Screw	Adjust the Record Head Azimuth Alignment Screw to obtain maximum readings for both channels on the AC voltmeter. Refer to "Record Head Height Adjustment and Azimuth Alignment" in item 4.5. Note: Repeat Steps 13 and 14 two or three times to obtain optimum performance.
15	Record Level Calibration and Recording Bias Current Adjustment	400 Hz (0 dB), 15 kHz (-20 dB) and 10 kHz/20 kHz (-20 dB) to Input Jacks	AC Voltmeter to Output Jacks	Record, Playback Monitor - Source/Tape - ZX/SX/EX Eq. - 70 μ s (ZX/SX) 120 μ s (EX) Dolby NR - OFF/B/C	Main P.C.B. (Level) ZX:VR103 VR203 SX:VR102 VR202 EX:VR101 VR201 (Bias) ZX:VR115 VR215 SX:VR116 VR216 EX:VR117 VR217	Adjustment should be made in the order of ZX, SX and EX. 1. Set the Monitor switch to Source. 2. Feed in 400 Hz, and set the Input Level control to obtain 0 dB (500 mV) on the AC voltmeter. 3. Set the Monitor switch to tape. 4. Load a reference ZX tape, reference SX tape and reference EXII tape. 5. Set Record Cal. VR103 (VR203) for ZX, VR102 (VR202) for SX and VR101 (VR201) for EXII tape to their center position. 6. Adjust Bias VR115 (VR215) for ZX, VR116 (VR216) for SX and VR117 (VR217) for EXII tape to obtain maximum reading on the AC voltmeter. 7. Feed in 15 kHz (-20 dB) and adjust Bias VR115 (VR215), VR116 (VR216) and VR117 (VR217) to obtain the same readings as source monitor levels on the AC voltmeter.

(to be continued)

STEP	ITEM	SIGNAL SOURCE	OUTPUT CONNECTION	MODE	ADJUSTMENT	REMARKS
						<ol style="list-style-type: none"> 8. Feed in 400 Hz (0 dB) and adjust Record Cal. VR103 (VR203), VR102 (VR202) and VR101 (VR201) to obtain 0 dB (500 mV) on the AC voltmeter. 9. Repeat above 7 and 8 two or three times to obtain optimum performance. 10. Feed in 10 kHz and 20 kHz (-20 dB), record and play them back, and check whether the playback levels are within the following ranges. With Dolby NR OFF: -20 dB \pm3 dB Level difference between Dolby NR OFF and B: \pm2 dB Level difference between Dolby NR OFF and C: \pm3 dB 11. Check that the total harmonic distortion is less than 0.9% for ZX tape and 1.0% for SX and EXII tapes. If satisfactory results are not obtained, re-adjust VR105 (VR205) referring to Step 9 "Playback Frequency Response Adjustment" and repeat above steps.
16	Overall Frequency Response Adjustment	400 Hz (0 dB) and 20 Hz to 20 kHz (-20 dB) to Input Jacks	AC Voltmeter to Output Jacks	Record, Playback Monitor - Source/ Tape - ZX/SX/EX Eq. - 70 μ s (ZX/SX) 120 μ s (EX) Dolby NR - OFF	Main P.C.B. L105 L205	<ol style="list-style-type: none"> 1. Set the Monitor switch to Source. 2. Feed in 400 Hz and adjust the Input Level control to obtain -20 dB on the AC voltmeter. 3. Set the Monitor switch to Tape. 4. Feed in 20 Hz to 20 kHz (-20 dB) and check to insure whether the output levels are within -20 dB \pm3 dB. 5. If above is not sufficient, adjust L105 (L205) to obtain approx. -20 dB at 20 kHz. 6. Conduct step 15 "Record Level Calibration and Recording Bias Current Adjustment". 7. If above is not sufficient, precise re-adjustment of step 9 "Playback Frequency Response", replacement of Playback Head or Record Head, check on item 4.7 "Tape Travelling Check" will be required.

7. MECHANISM ASS'Y AND PARTS LIST

7.1. Synthesis

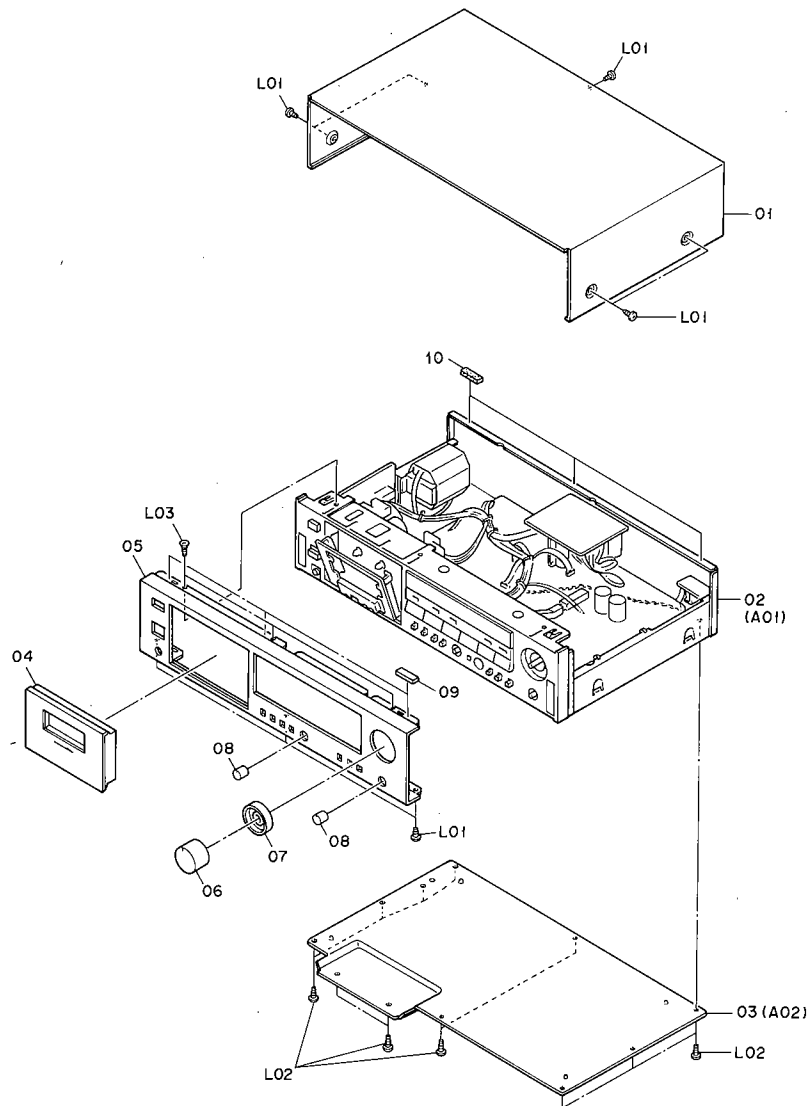

Fig. 7.1

Schematic Ref. No.	Part No.	Description	Q'ty	Schematic Ref. No.	Part No.	Description	Q'ty
7.1. Synthesis				09	0J05453A	Top Cover Cushion	3
				10	0J05407A	Top Cover Sheet	3
				L01	0E03433A	BT3x6 ⊕ Binding Projected (Black Chromate)	8
				L02	0E00868A	BT3x8 ⊕ Binding	11
				L03	0E03054A	BT3x8 ⊕ Countersunk	3
01	0H05111A	Top Cover	1		0M03797A	Voltage Seal 240V (CR-3E (UK))	1
02	JA04300A	Chassis Ass'y (CR-3 (Australia))	1		0M03844B	Power Cord Label (CR-3E (UK))	1
	JA04299A	Chassis Ass'y (CR-3 (Other))	1		0M05148A	Production Date Seal (CR-3A)	1
	JA04302A	Chassis Ass'y (CR-3 (Saudi Arabia))	1		0M04381A	EP Approval Label (CR-3E Europe)	1
	JA04303A	Chassis Ass'y (CR-3A (U.S.A.))	1		0M04811A	Voltage Caution Sheet (CR-3 (Other & Saudi Arabia))	1
	JA04297A	Chassis Ass'y (CR-3A (Canada))	1		0M05065A	Pass Label	1
	JA04301A	Chassis Ass'y (CR-3E (Europe))	1		0M05067A	CSA Approval Label (CR-3A (Canada))	1
	JA04296A	Chassis Ass'y (CR-3E (UK))	1		0M05068A	LA Label (CR-3A (U.S.A.))	1
	JA04298A	Chassis Ass'y (CR-30)	1		0M05056A	Serial No. Seal (CR-3, CR-3E & CR-30)	1
03	JA04319A	Bottom Cover Ass'y (CR-3 & CR-3E)	1		0M05069A	Serial No. Seal (CR-3A)	1
	JA04329A	Bottom Cover Ass'y (CR-3A)	1		0M05115A	Amp. Number Seal	1
	JA04340A	Bottom Cover Ass'y (CR-30)	1		0M05111A	F Mark Approval Seal (CR-3E (Europe))	1
04	HA05312A	Cassette Case Cover Ass'y	1		MA01001A	F. Code Label Ass'y (CR-3, CR-3E & CR-30)	1
05	0H05142B	Front Panel (CR-3)	1				
	0H05140B	Front Panel (CR-3A)	1				
	0H05141B	Front Panel (CR-3E)	1				
	0H05143B	Front Panel (CR-30)	1				
06	HA05340A	Rec. Volume Knob Ass'y	1				
07	HA05338A	Rec. Balance Knob Ass'y	1				
08	HA05339A	Bias Volume Knob Ass'y	2				

7.2. Chassis Ass'y (A01)

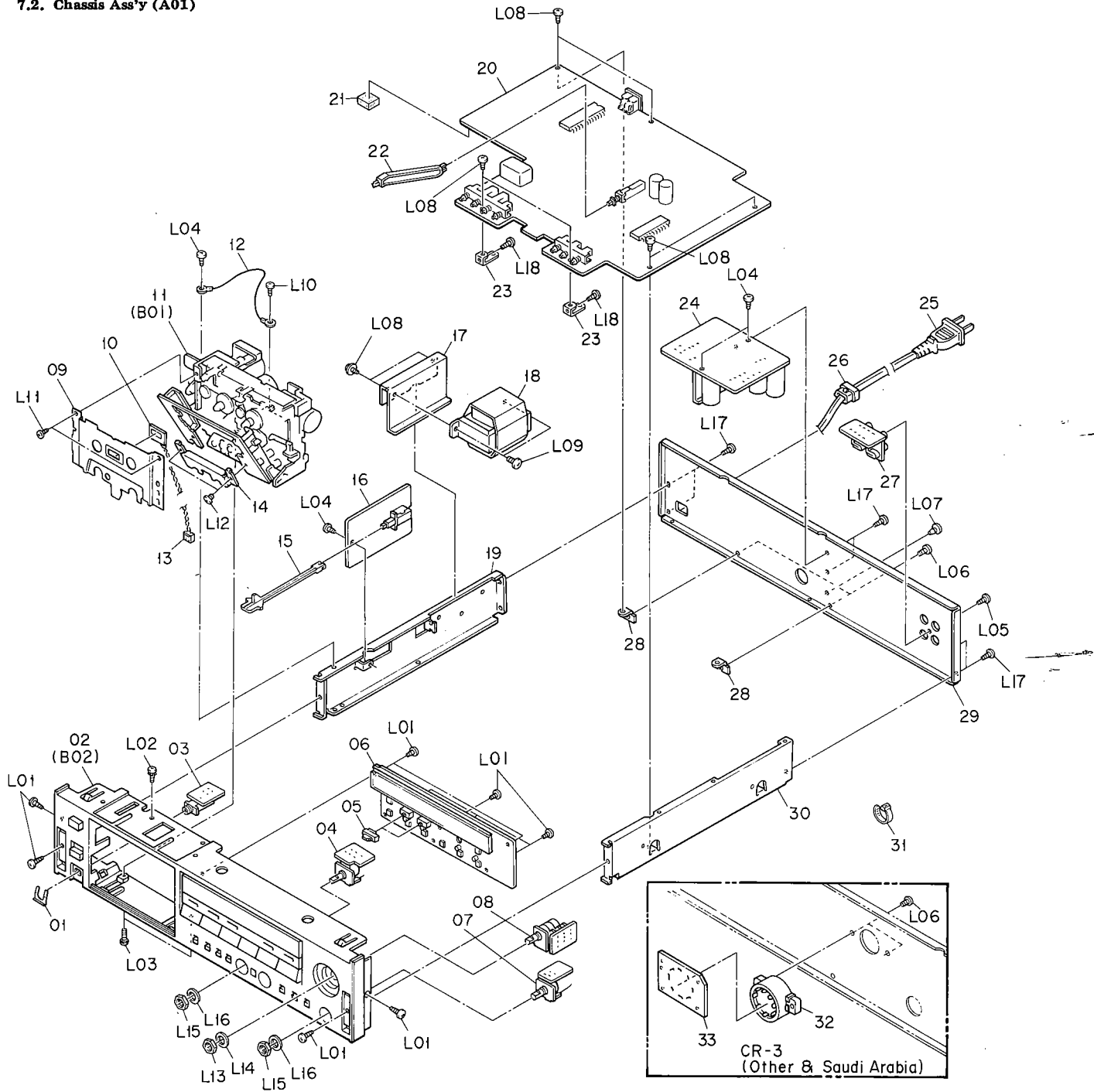
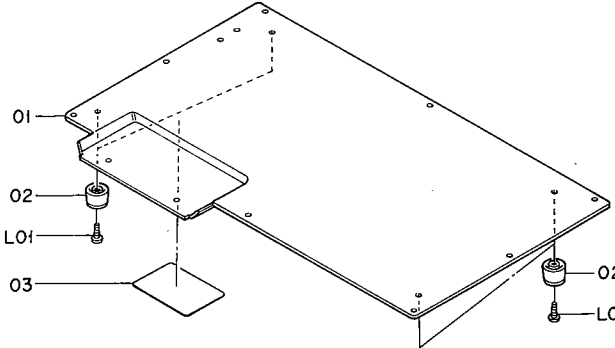

Fig. 7.2

Schematic Ref. No.	Part No.	Description	Q'ty	Schematic Ref. No.	Part No.	Description	Q'ty
7.2. Chassis Ass'y (A01)				L12	0E03202A	M2.6x3 @ Binding (Black Chromate)	2
A01	JA04300A	Chassis Ass'y (Australia))	1	L13	0E03375A	Nut Hex. M9	1
	JA04299A	Chassis Ass'y (CR-3 (Other))	1	L14	0E03376A	Washer 9mm	1
	JA04302A	Chassis Ass'y (CR-3 (Saudi Arabia))	1	L15	0E03382A	Nut Hex. M7	2
	JA04303A	Chassis Ass'y (CR-3A (U.S.A.))	1	L16	0E03383A	Washer 7mm	2
	JA04297A	Chassis Ass'y (CR-3A (Canada))	1	L17	0E03433A	BT3x6 @ Binding Projected (Black Chromate))	6
	JA04301A	Chassis Ass'y (CR-3E (Europe))	1	L18	0E00846A	BT3x8 @ Pan	2
	JA04296A	Chassis Ass'y (CR-3E (UK))	1	-	0M04075C	Fuse Caution (CR-3A)	1
	JA04298A	Chassis Ass'y (CR-30) Serial No.: A13201001 -	1	7.3. Bottom Cover Ass'y (A02)			
01	OJ05427A	Mount Plate	1	A02	JA04319A	Bottom Cover Ass'y (CR-3 & CR-3E)	1
02	HA05306A	Front Escutchen Ass'y	1		JA04329A	Bottom Cover Ass'y (CR-3A)	1
03	BA06929A	Headphone P.C.B. Ass'y	1		JA04340A	Bottom Cover Ass'y (CR-30) Serial No.: A13201001 -	1
04	BA06928A	Bias Tune Volume P.C.B. Ass'y	1	01	OJ05401A	Bottom Cover	1
05	OH05095A	Slide Button	2	02	OJ05420A	Leg N (CR-3, CR-3A & CR-3E)	4
06	BA06932A	Control P.C.B. Ass'y	1		HA05357A	Leg Ass'y (CR-30)	4
07	BA06927A	Output Volume P.C.B. Ass'y	1	03	0M04377B	Caution Label (CR-3A)	1
08	BA06926A	Input Volume P.C.B. Ass'y	1	L01	0E00888A	BT3x12 @ Binding	4
09	OH05166A	Cover Plate	1	-	OJ05461A	Leg Felt N (CR-3, CR-3A & CR-3E)	4
10	OB12580A	LED P. Green SLF-7250	1	7.3. Bottom Cover Ass'y (A02)			
11	CA08885A	Mechanism Ass'y	1				
12	OB80150A	GND Wire Ass'y	1	Fig. 7.3			
13	OB83132A	2P Connector	1				
14	OH04415C	Head Mounting Cover	1				
15	OJ05402A	Power Switch Joint	1				
16	BA06935A	Fuse P.C.B. Ass'y (CR-3 & CR-3E)	1				
	BA06934A	Fuse P.C.B. Ass'y (CR-3A)	1				
	BA06936A	Fuse P.C.B. Ass'y (CR-30)	1				
17	OJ05417C	Transformer Holder	1				
18	OB50100A	Power Transformer (CR-3 (Australia) & CR-3E)	1				
	OB50101A	Power Transformer (CR-3 (Other & Saudi Arabia))	1				
	OB50099A	Power Transformer (CR-3A)	1				
	OB50102A	Power Transformer (CR-30)	1				
19	OJ05392A	Side Chassis L	1				
20	BA06915A	Main P.C.B. Ass'y	1				
21	OJ05451A	P.C.B. Cushion	1				
22	OJ05403A	Monitor Switch Joint	1				
23	OJ05394A	P.C.B. Holder Front	2				
24	BA06931A	Power Supply P.C.B. Ass'y	1				
25	OB05241A	Power Cord (CR-3 (Australia))	1				
	OB08533A	Power Cord (CR-3 (Other & Saudi Arabia))	1				
	OB08504A	Power Cord (CR-3A)	1				
	OB08093U	Power Cord (CR-3E (Europe))	1				
	OB08348A	Power Cord (CR-3E (UK))	1				
	OB08219B	Power Cord (CR-30)	1				
26	OB90280A	Cord Bushing (CR-3 (Australia), CR-3A & CR-3E)	1				
	OB90283A	Cord Bushing (CR-3 (Other & Saudi Arabia) & CR-30)	1				
27	BA06930A	Pin Jack P.C.B. Ass'y	1				
28	OJ05395A	P.C.B. Holder Rear	2				
29	OH05119A	Rear Panel (CR-3 (Australia))	1				
	OH05121A	Rear Panel (CR-3 (Other & Saudi Arabia))	1				
	OH05117B	Rear Panel (CR-3A)	1				
	OH05118A	Rear Panel (CR-3E)	1				
	OH05120A	Rear Panel (CR-30)	1				
30	OJ05393A	Side Chassis R	1				
31	OB08515A	Insu-lock SKB80	18				
32	OB81771A	Voltage Selector (CR-3 (Other & Saudi Arabia))	1				
33	OB60503A	Voltage Selector P.C.B. (CR-3 (Other & Saudi Arabia))	1				
L01	0E00868A	BT3x8 @ Binding	10				
L02	0E03212A	BT2.6x6 @ Binding with Toothed Lock Washer	1				
L03	0E03435A	M2.6x6 @ Binding with Toothed Lock Washer	2				
L04	0E00857A	BT3x6 @ Binding	4				
L05	0E00921A	BT3x8 @ Binding (Black Chromate)	1				
L06	0E00985A	M3x6 @ Binding (Black Chromate) (CR-3 (Australia), CR-3A, CR-3E & CR-30)	2				
	0E00985A	M3x6 @ Binding (Black Chromate) (CR-3 (Other & Saudi Arabia))	4				
L07	OJ05108A	Hole Plug No.9	1				
L08	0E03432A	BT3x6 @ Tapping (Black Chromate)	8				
L09	0E03438A	BT4x6 @ Binding	2				
L10	0E00859A	BT2.6x6 @ Binding	1				
L11	0E03437A	FT2.5x3.5 @ Pan (Black Chromate)	2				

Schematic Ref. No.	Part No.	Description	Qty	Schematic Ref. No.	Part No.	Description	Qty
7.4. Mechanism Ass'y (B01)				81	OC82718A	Thrust plate	2
B01	CA08885A	Mechanism Ass'y Serial No.: A13201001 -	1	82	OC80037A	Insu-Lock	3
01	OC80021A	Eject Lever	1	83	CA80734A	5P Connector	1
02	OC82720A	Eject Lever Spring	1	L01	OE00181A	E-Ring 3mm	3
03	CA80006A	Pneumatic Damper Ass'y	1	L02	OE03235A	Plastic Washer 2x5x0.25	1
04	OC80019B	Eject Spring	1	L03	OE03052A	CS Stopper Ring 2.4mm	2
05	OC82723A	Cassette Case Holder L	1	L04	OE03236A	M2x5 @ Pan (3A)	3
06	OC80617A	Back Tension Arm Spring	1	L05	OE03229A	FT2.5x6 @ Pan	8
07	OC80618A	Back Tension Arm Collar	1	L06	OE03043A	FT2.5x10 @ Pan	2
08	OC80619A	Back Tension Arm	1	L07	OE03225A	Washer 1.8x3.8x0.5	2
09	OC80620A	Back Tension Arm Pulley	1	L08	OE03226A	Washer 2.1x4.5x0.1	3
10	OC80621A	Back Tension Arm Belt	1	L09	OC81421A	Supply Pressure Roller Arm Adjustment	1
11	OC80013A	Lock Lever Spring	1	L10	OC82725A	M2.6x9 @ Pan with Washer	3
12	OC80014A	Lock Lever Collar	1	L11	OE03049A	Washer 1.8x3.2x0.5	2
13	OC80015B	Lock Lever	1	L12	OE00976A	M2x5 @ Binding	5
14	CA80366A	Supply Pressure Roller Arm Ass'y	1	L13	OE00025A	Spring Washer 2mm	2
15	OC81420A	Supply Pressure Roller Arm Spring	1	L14	OE00117A	Washer 2x4.3x0.4	5
16	OC81422A	Supply Pressur Roller Arm Track Spring	1	L15	OE00866A	M2.6x4 @ Binding	1
17	CA80726A	Supply Reel Hub Ass'y	1	L16	OC80774A	Plate Washer L	1
18	OC80612A	Spring Holder	2	L17	OC80773A	Plate Washer R	1
19	OC80614A	Supply Reel Hub Spring	1	L18	OE03228A	FT3x4 @ Pan	1
20	CA80200A	Cassette Case Ass'y	1	L19	OE03232A	M1.7x7 @ Pan	1
21	OC80762A	Head Hight Adjustment Gear	2	L20	OE03222A	Washer 1.8x3.8x0.3	1
22	OC80761A	Head Hight Adjustment Screw	4	L21	OE00691A	M2x3 @ Pan	2
23	OC80763A	Azimuth Alignment Screw	2	L22	OE00222A	E-Ring 2mm	1
24	OC80605A	Wire Clamper	1	L23	OE03035A	M2x3.2 @ Truss	3
25	CA08637A	Head Mount Base Sub Ass'y	1	L24	OE03227A	Washer 2.7x5x0.5	1
26	CA08659A	R-3L Record Head Ass'y	1	L25	OE03231A	M2x30 @ Pan	2
27	OC08776A	Head Plate Spring (L)	1	L26	OE03041A	FT2.5x4 @ Pan	2
28	CA80731A	4P Connector	1	L27	OE03233A	Wahser 2.6x8x1	1
29	OC80003A	Head Base Hold Plate	1	L28	OE03230A	ST2.6x12 @ Pan	1
30	OC80004A	Steel Ball 3mm	1	L29	OC82717A	Capstan Washer T	1
31	GA02201A	E-4F Erase Head	1	L30	OE03237A	Nut Hex. M2.6	1
32	CA80733A	2P Connector	1	L31	OE03045A	M2.6x3 @ Binding	2
33	OC08768A	E.H. Hold Plate	1	L32	OE00694A	Nut Hex. M2	1
34	OC08889A	E.H. Hold Plate Tapering Spring	2	L33	OE03234A	M2x3 @ Pan	2
35	OC08886A	E.H. Hold Plate Spring	1	L34	OE03044A	FT2.5x20 @ Pan	1
36	OC80007A	Steel Ball 2mm	3	L35	OC82716A	Capstan Washer S	1
37	CA08658B	P2H-3L Playback Head Ass'y	1	L36	OE03042A	FT2.5x5 @ Pan	9
38	OC08775A	Head Plate Spring (R)	1	L37	OE00912A	Washer 2.6x4.7x0.25 (Poly)	2
39	CA80732A	4P Connector	1				
40	OC08771A	Tape Guide Plate	1				
41	CA80365A	Head Base Sub Ass'y	1				
42	OC82711A	Head Base Spring	1				
43	CA80725A	Take-up Reel Hub Ass'y	1				
44	OC80613A	Take-up Reel Hub Spring	1				
45	CA80368A	Take-up Pressure Roller Arm Ass'y	1				
46	OC81423A	Take-up Pressure Arm Spring	1				
47	OC80610A	Cassette Case Spring	1				
48	OC80622A	Switch Hold Plate	1				
49	OC80623A	Switch Plate	2				
50	OC80624A	Switch Collar A	2				
51	OC80626A	Leaf Switch	1				
52	OC80625A	Switch Collar B	2				
53	OC80017B	Record Protector Lever	1				
54	CA80736A	Mechanism Chassis	1				
55	OC80022B	Cassette Hold Spring	1				
56	CA80011A	Shut-off P.C.B. Ass'y	1				
57	CA80204A	Brake Ass'y	1				
58	OC80628A	Brake Spring B	1				
59	OC80630A	Brake Arm Collar	1				
60	OC80629A	Brake Arm	1				
61	OC82724A	Reel Motor Holder	1				
62	CA80735A	9P Connector	1				
63	CA80730A	Reel Motor Ass'y	1				
64	OC81417A	Cam Gear B	1				
65	OC81418A	Control Motor Holder	1				
66	OC81416A	Thrust Spring B	1				
67	OC80027A	Mode Switch	3				
68	OC81415A	Warm Thrust Bush	1				
69	CA80007A	Control Motor Ass'y	1				
70	OC80010D	Cassette Case Holder R	1				
71	OC80012A	Eject Sensor Switch	1				
72	OC82701A	Supply Capstan Flange	1				
73	OC80029A	Back Tesion Spring	2				
74	OC82699A	Supply Flywheel	1				
75	OC82702A	Capstan Belt	1				
76	OC82714A	Flywheel Holder	1				
77	OC82726A	Floating Rubber	3				
78	CA80729A	Capstan Motor Ass'y	1				
79	OC82700A	Take-up Capstan Flange	1				
80	OC82698A	Take-up Flywheel	1				

7.4. Mechanism Ass'y (B01)

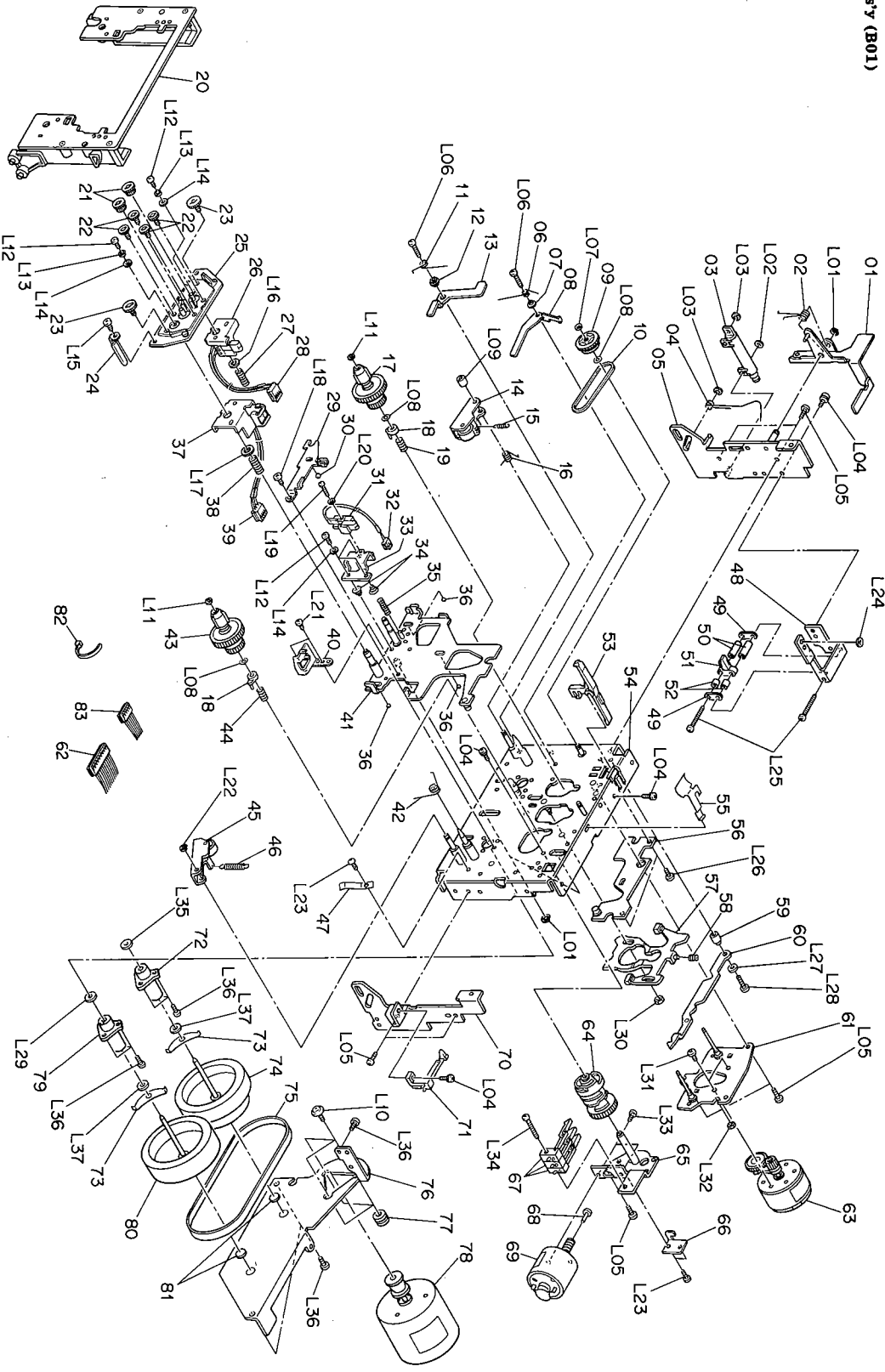

Fig. 7.4

7.5. Front Escutcheon Ass'y (B02)

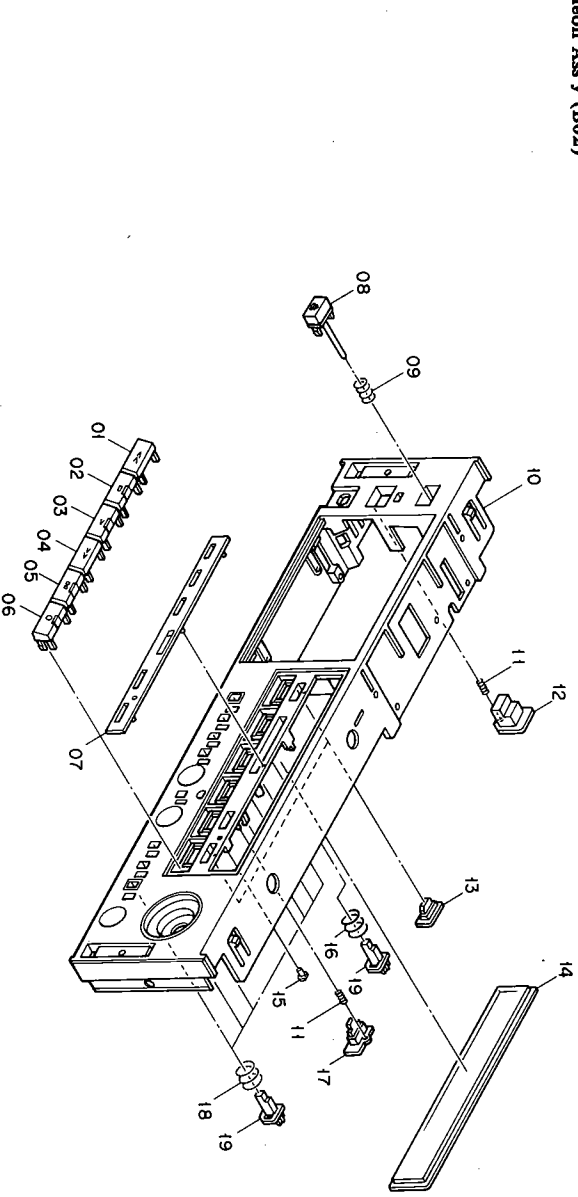
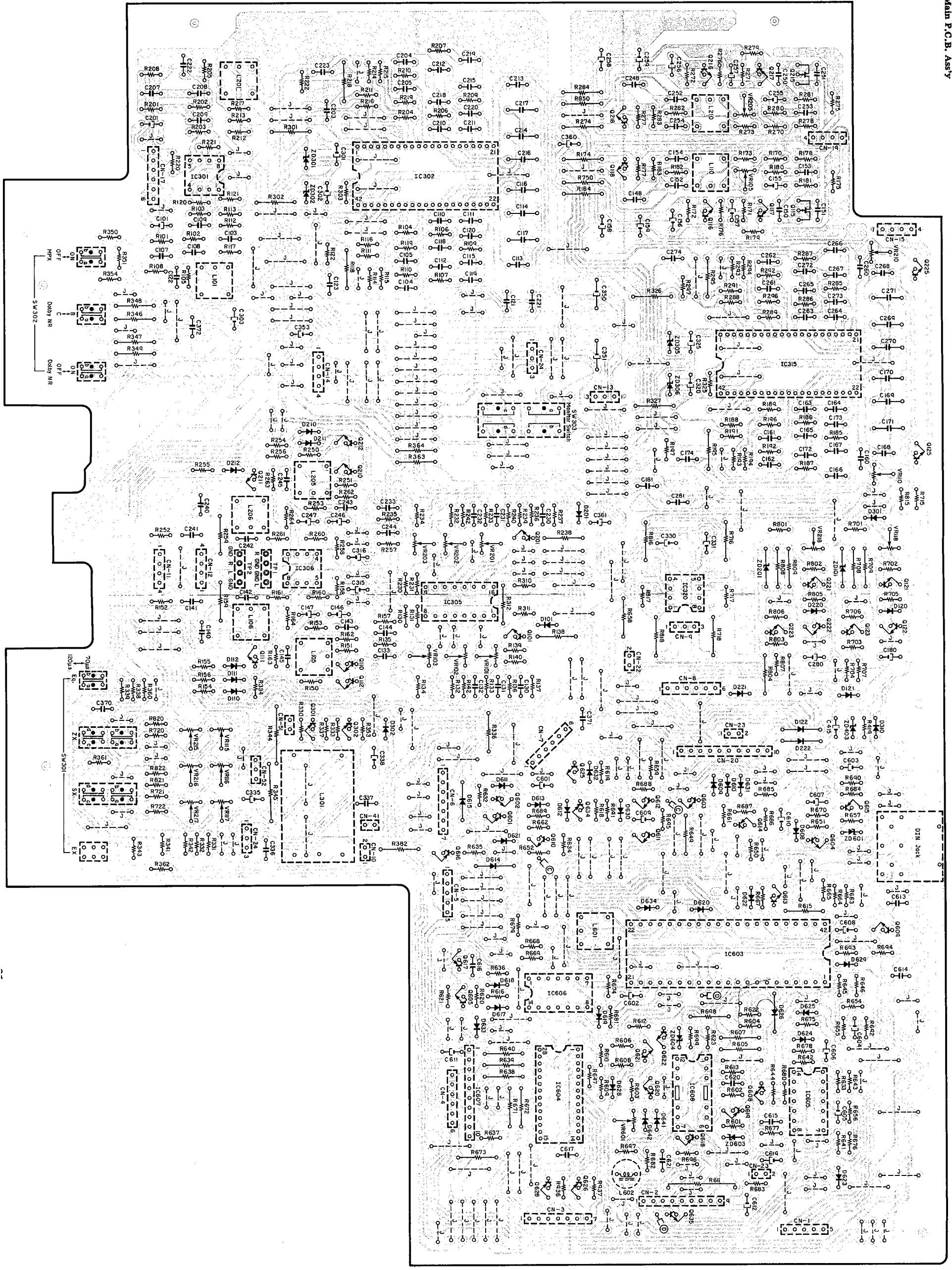

Fig. 7.5

Schematic Ref. No.	Part No.	Description	Qty
7.5. Front Escutcheon Ass'y (B02)			
B02	HA05306A	Front Escutcheon Ass'y Serial No.: A13201001-	1
01	OH05126A	Rewind Button	1
02	HA05389A	Stop Button Ass'y	1
03	HA05343A	Play Button Ass'y	1
04	OH05129A	F.F. Button	1
05	HA05361A	Pause Button Ass'y	1
06	OH05098B	Rec. Button Ass'y	1
07	HA05360A	Function Plate	1
08	HA05344A	Eject Button Ass'y	1
09	OH05404A	Front Escutcheon	1
10	OH05122B	Eject Knob Spring	1
11	OH05405A	Front Escutcheon	1
12	OH05125B	Power Switch Knob Spring	1
13	OH05094A	Function Button	2
14	OH05101A	Display Lens	1
15	OH05103A	LED Lens B	1
16	OH05452B	EX Switch Spring	1
17	OH05096A	Counter Button	1
18	OH05406A	Push Switch Button Spring	6
19	OH05097A	Push Button	7
—	OH05456A	LED Lens Adhesive Tape	2
—	OH05459A	F. Plate Adhesive Tape	2



9. SCHEMATIC DIAGRAM

9.1. IC Block Diagrams

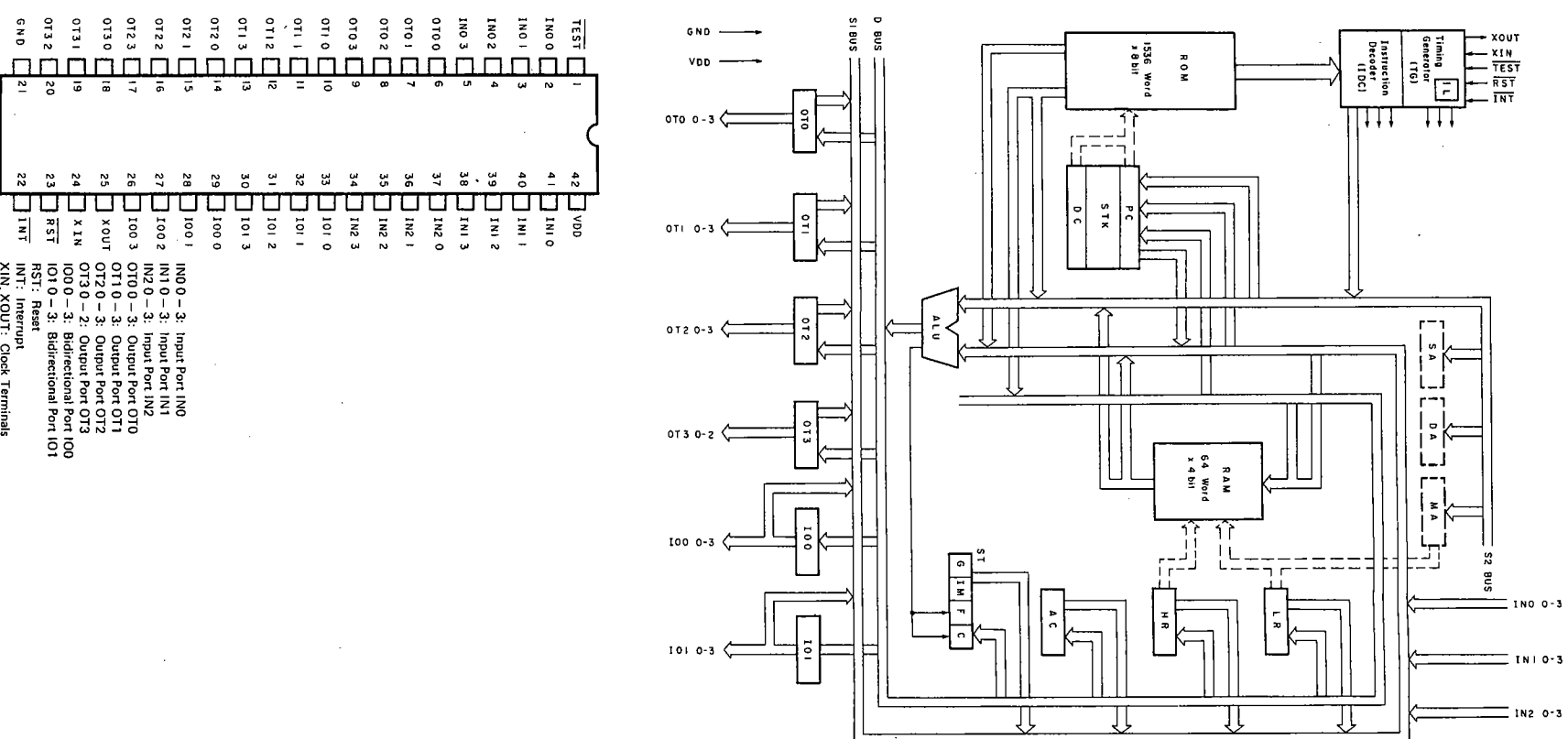

IC603 (TMP4315BP-1814)

Pin No.	Signal Name	In/Out	Function
1	Test	—	Not used.
2	Cam (0)	In	Mechanism position detecting signals. Mechanism mode can be sensed according to states of Cam (0), Cam (1) and Cam (2).
3	Cam (1)	In	
4	Cam (2)	In	
5	Eject	In	Eject signal. Active L. Used to detect whether the Cassette Case is open. When it is open, this signal is L. In this condition, the CR-3 is in Stop mode and no pushbutton operation is enabled.
6	R.M. Fwd.	Out	Reel Motor Forward signal. Active L. Reel Motor Running (Forward)
7	R.M. Rev.	Out	Reel Motor Reverse signal. Active L. Reel Motor Running (Reverse)
8	C.M. Fwd.	Out	Control Motor Forward signal. Active L. Control Motor Running (Forward)
9	C.M. Rev.	Out	Control Motor Reverse signal. Active L. Control Motor Running (Reverse)
10	R.M. Play	Out	Reel Motor Play signal. Active H. In Play mode, C.M. Fwd. becomes L, and R.M. Play becomes H.
11	Capstan M	Out	Capstan Motor Run signal. Active H. In Play, Pause, or Rec./Play mode, Capstan M is H and Capstan Motor runs. In other modes, Capstan M is L, so Capstan Motor is stopped.
12	E. Brake	Out	Electric Brake signal. Active H. Generates H pulse upon change in mode.
13	Source Mute	Out	Source Mute signal. Active H. Issues H pulse for 3.3 sec after power is turned ON. Used for timer recording circuit.
14	Line Mute	Out	Line Output Mute signal. Active H. Stays at L only in Play or Rec./Play mode. Deactivates mute of line outputs.
15	Rec. Mute	Out	Record Mute signal. Active H. Stays at L only in Rec./Play mode. Releases record mute.
16	Rew. Mode	Out	Rewind Mode signal. Active L.
17	F.F. Mode	Out	F.F. Mode signal. Active L.
18	Pause Mode	Out	Pause Mode signal. Active L. Used for lighting of Pause lamp.
19	Play Mode	Out	Play Mode signal. Active L. Used for lighting of Play lamp.
20	Rec. Mode	Out	Record Mode signal. Active L. Used for lighting of Record lamp.
21	Vss	In	GND.
22	INT	In	Interrupt signal. Active L. Allows input of shut-off pulse train. Detects tape running, i.e., rotation of Take-up Reel Hub.
23	Reset	In	Reset signal. Active L. Held at L for approx. 100 msec after power is turned ON. Upon change of this signal to H, IC603 starts operation.
24	EXtal	In	External circuit for clock oscillation. Oscillating frequency = 550 kHz.
25	Xtal	In	Not used.
26	Rec.	—	Not used.
27	AMS	—	Not used.
28	Zero	In	Not used.
29	Memory	In	Memory Switch ON signal. Active H. Held at H when Memory switch is set to ON. (With this switch set to ON, tape will stop automatically when the tape counter indication "000" is reached during rewind or fast-forward.)
30	A. Rew.	In	Auto Rewind and Auto Play signals. Active L. These signals are L when Timer switch is set to OFF and, at the same time, Auto Repeat switch is set to ON. (With these signals set to L, auto repeat function is performed and the playback/rewind cycle is continuously repeated between the tape end and the tape start. Furthermore, if Memory switch is set to ON, the playback/rewind cycle is continuously repeated between the tape end and the tape counter indication "000".)
31	A. Play	In	
32	T. Rec.	In	Timer Recording signal. Active L. When power is turned ON with Timer switch in Record position, becomes L for approx. 3.3 sec, causing unattended recording to start.
33	T. Play	In	Timer Play signal. Active L. Held at L upon setting of Timer switch to the Play position.
34	K. Pause	In	Pause button input terminal. Becomes L upon push of Pause button.
35	K. Rec.	In	Record button input terminal. Becomes L upon push of Record button.
36	R. Mute	—	Not used.
37	SEA	—	Not used.
38	K. Play	In	Play button input terminal. Becomes L upon push of Play button.
39	K. F.F.	In	F.F. button input terminal. Becomes L upon push of F.F. button.
40	K. Rew.	In	Rewind button input terminal. Becomes L upon push of Rewind button.
41	K. Stop	In	Stop signal input terminal. At L, stops all operations.
42	VDD	In	+5 V.



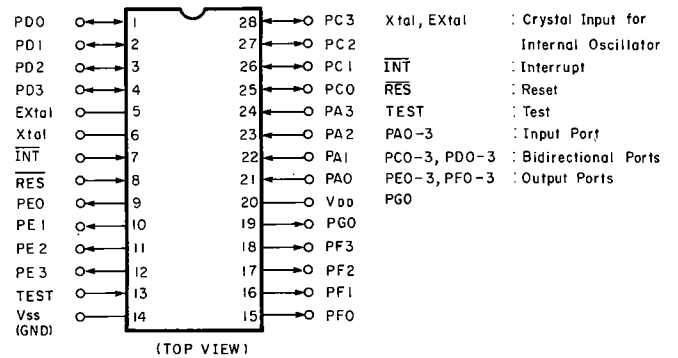
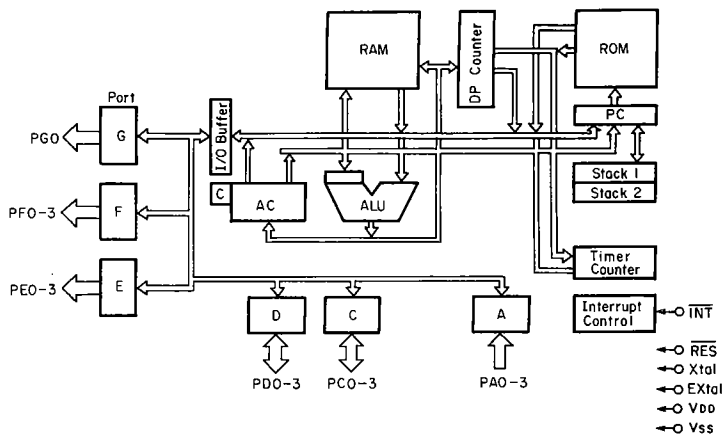
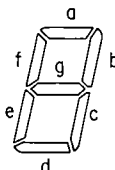

Fig. 9.1.2 4-Bit Micro-processor LM6416E-106

IC604 (LM6416E-106)

Pin No.	Signal Name	In/Out	Function
1	CLR	In	Reset button input terminal. Upon push of Reset button, Reset signal becomes L and counter is cleared to "0000".
2	K. Play	In	Play button input terminal. Becomes L upon push of Play button.
3	K. F.F.	In	F.F. button input terminal. Becomes L upon push of F.F. button.
4	K. Rew.	In	Rewind button input terminal. Becomes L upon push of Rewind button.
5	EXtal	In	Terminals for clock oscillation, RC circuit is connected.
6	Xtal	In	
7	INT	In	Interrupt signal. Active L. Shut-off pulse train is input. Input pulse train is counted for tape counter display.
8	Reset	In	Reset signal. Active L. Held at L for approx. 100 msec after power is turned ON.
9	f	Out	Display segment drive signals. Segment lights at L.
10	b		
11	a		
12	d		
13	Test	In	Not used.
14	Vss	In	GND.
15	g	Out	Display segment drive signals. Segment lights at L.
16	a		
17	c		
18	D4	Out	The 4th (rightmost) digit select signal. Active L.



Pin No.	Signal Name	In/Out	Function			
19	Motor Slow	Out	Motor Slow signal. Active L. When Motor Slow signal is L, reel motor speed is reduced.			
20	VDD	In	+5 V			
21	L. Rew.	In	LED Rewind signal. Active L. When mode is changed to Rewind, L. Rew. signal becomes L after H period of E. Brake signal ended.			
			<table border="1"> <tr> <td>Mode</td> <td>F. F.</td> <td>Rew.</td> </tr> </table>	Mode	F. F.	Rew.
Mode	F. F.	Rew.				
22	L. F.F.	In	LED F.F. signal. Active L. Timing is similar to L. Rew. signal.			
23	L. Stop	In	LED Stop signal. Active L. Timing is similar to L. Rew. signal.			
24	Memory Stop	In	Memory Stop switch input terminal of Memory Stop/Auto Repeat switch. Memory Stop signal is L when Memory Stop is selected.			
25	Memory Play	In	Not used.			
26	D3	Out	The 3rd, 2nd, and 1st (leftmost) digit select signals. Active L.			
27	D2					
28	D1					

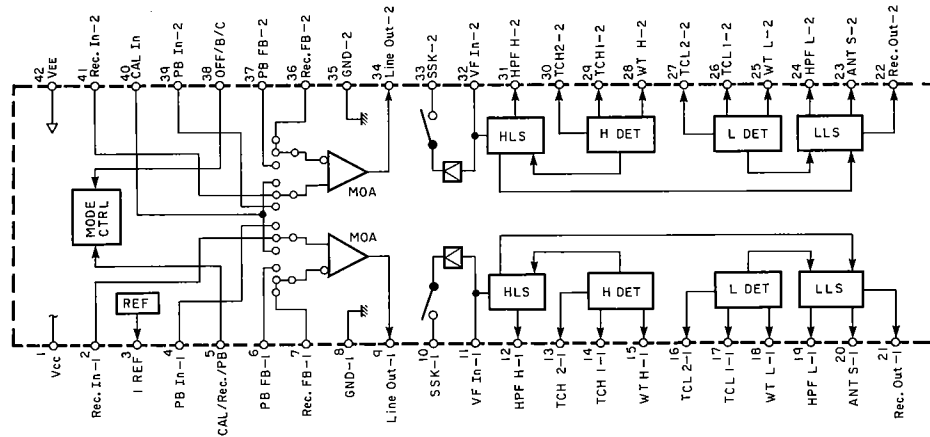

Fig. 9.1.3 Dolby NR IC CX20188

IC302/IC315 (CX20188)

Pin No.	Signal Name	Function
1	Vcc	Positive power supply input terminal.
2,41	Rec. In	Record signal input terminal.
3	I Ref.	Reference current input terminal.
4,39	PB In	PB signal input terminal.
5	CAL/Rec./PB	Calibration/Recording/Playback select terminal.
6,37	PB FB	Playback signal feedback terminal.
7,36	Rec. FB	Record signal feedback terminal.
8,35	GND	GND terminal.
9,34	Line Out	Line signal (decoded signal) output terminal.
10,33	SSK	Spectral skewing switch terminal.
11,32	VF In	Encode circuit input terminal.
12,31	HPF H	HLS high-pass filter terminal.
13,30	TCH 2	HLS detector time constant determination terminal 2.
14,29	TCH 1	HLS detector time constant determination terminal 1.
15,28	WT H	HLS weighting terminal.
16,27	TCL 2	LLS detector time constant determination terminal 2.
17,26	TCL 1	LLS detector time constant determination terminal 1.
18,25	WT L	LLS weighting terminal.
19,24	HPF L	LLS high-pass filter terminal.
20,23	ANT S	Anti-saturation terminal.
21,22	Rec. Out	Record signal (encoded signal) output terminal.
38	OFF/B/C	Dolby NR OFF/B-type/C-type select terminal.
40	CAL In	Calibration input terminal. Not used.
42	VEE	Negative power supply input terminal.

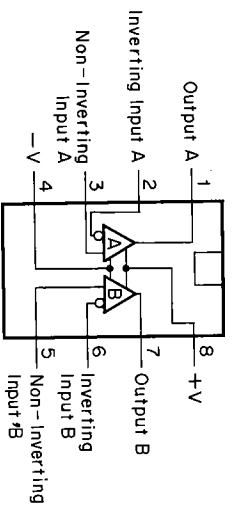

Fig. 9.1.4 Operational Amp. IC 4556D, 4560D, 2043DD, 2403D, 072DE

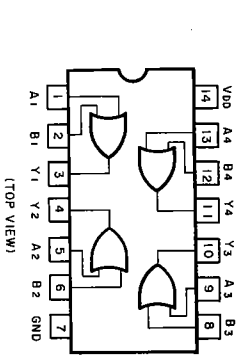

Fig. 9.1.5 OR Gate C-MOS IC APD4071BC

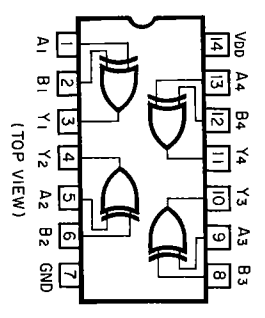

Fig. 9.1.6 Exclusive OR Gate C-MOS IC μPPD4030BC

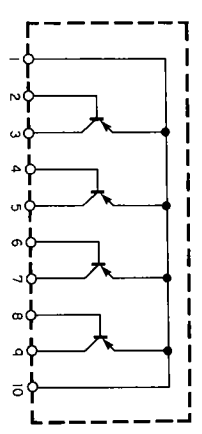

Fig. 9.1.7 Transistor Array TA64

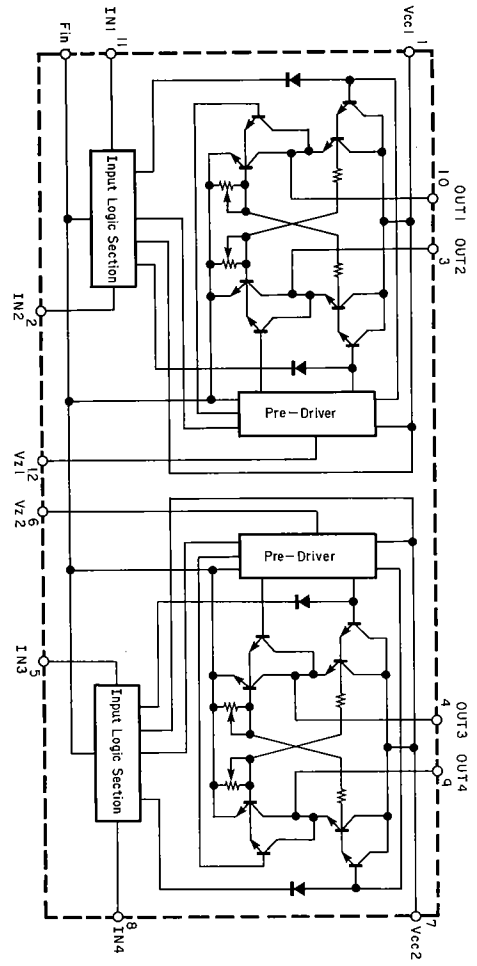

Fig. 9.1.8 Motor Driver IC IB1649

INPUT	OUTPUT	OPERATION
IN1/3	OUT1/3	Braking
IN2/4	OUT2/4	
1	0	For word (Reverse)
0	1	
0	0	Reverse (For word)
1	1	
1	0	Braking

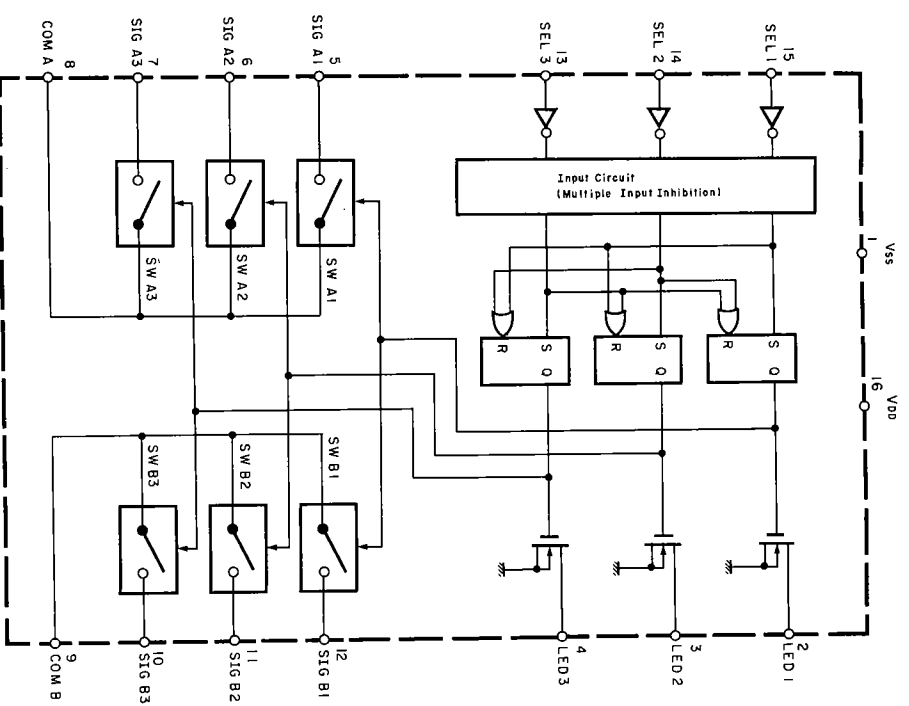

Fig. 9.1.9 Analog Switch Selector TC9145P

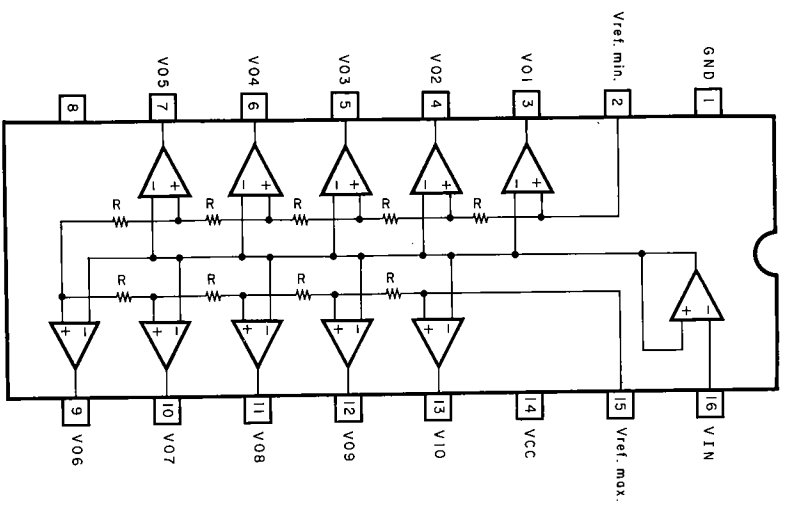

Fig. 9.1.10 Level Meter Driver TA7612AP

- 2SA562TM
 - 2SA733
 - 2SA933
 - 2SA952
 - 2SA970
 - 2SA1345
 - 2SC945
 - 2SC1740
 - 2SC2240
 - 2SC2878
 - 2SC3399
- 2SD471
- 2SB1015
 - 2SD1406
- 2SK371

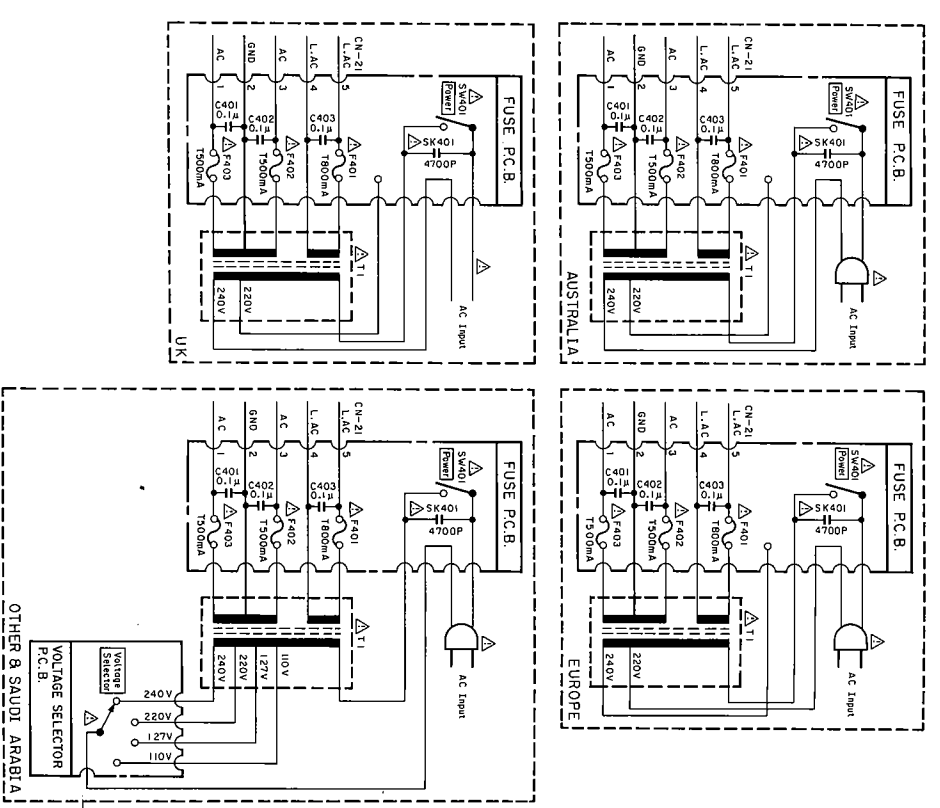
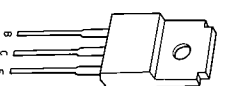
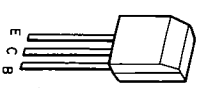
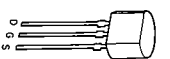



Fig. 9.2.1

WARNING:

Parts marked with the symbol  have critical characteristics. Use **ONLY** replacement parts recommended by the manufacturer. It is recommended that the unit be operated from a suitable DC supply or batteries during initial check-out procedures.

CAUTION:

Before returning the unit to the customer, make sure you make either (1) a leakage current check or (2) a line to chassis resistance check. If the leakage current exceeds 0.5 milliamp, or if the resistance from chassis to either side of the power cord is less than 240 k ohms, the unit is defective. **WARNING — DO NOT** return the unit to the customer until the problem is located and corrected.

Notes:

1. Diode is 1SS53, 1S1555, or 1SS176 unless otherwise specified.
2. 2SA733, 2SA608SP, 2SA1048 and 2SA1175 are interchangeable with each other.
3. 2SC945, 2SC536SP, 2SC2458 and 2SC2785 are interchangeable with each other.
4. Voltage measuring condition:
 - Stop mode (with no input signal) unless otherwise specified.
 - Tape: SX position, Eq.: 70 μ s
 - Monitor Switch: Tape
 - Timer Switch: OFF
 - Memory Stop/Auto Repeat Switch: OFF
 - MPX Switch: OFF
 - Dolby NR Switch: OFF
 - Play mode: Cassette with no tape played back.

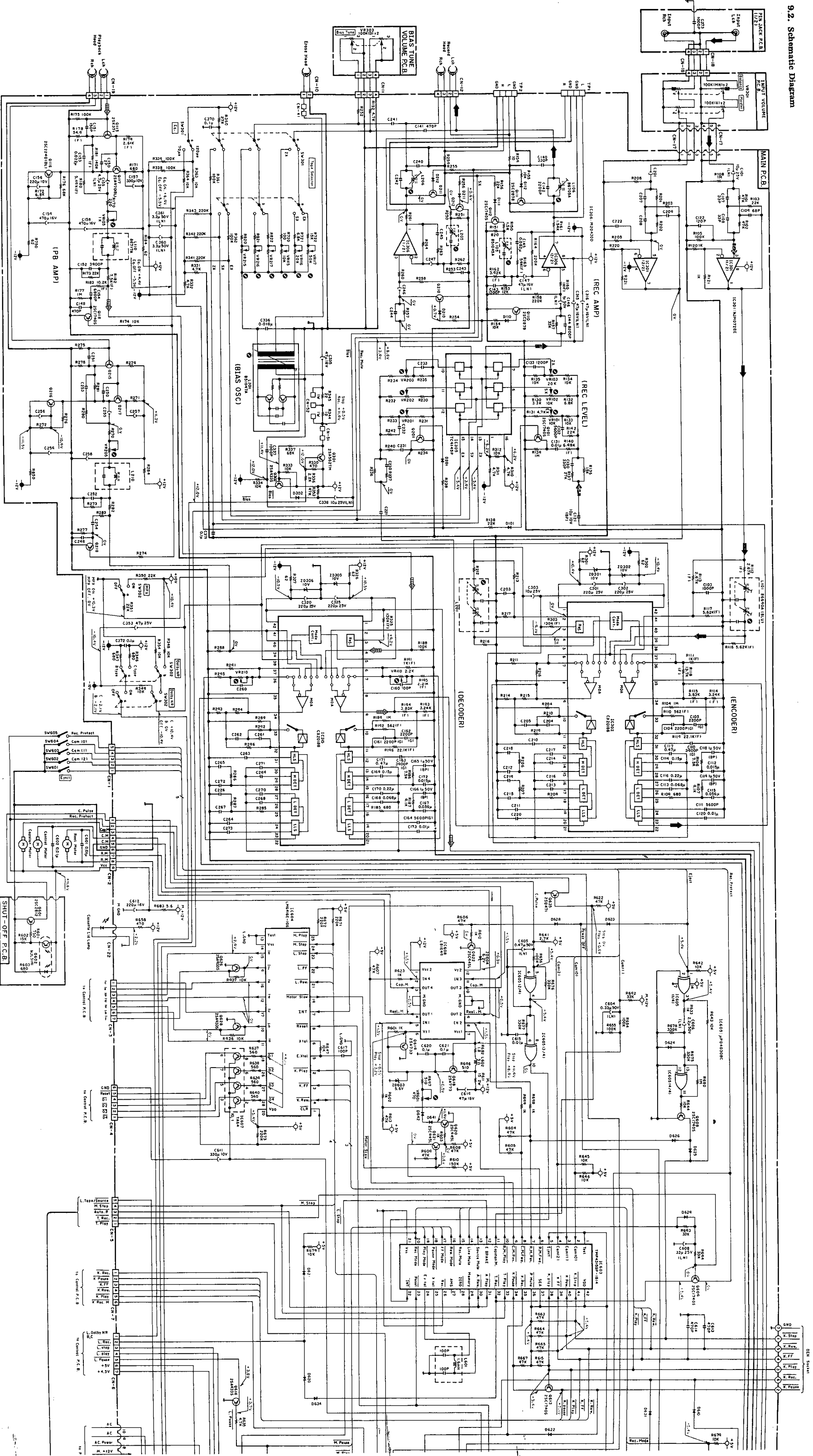

10. WIRING DIAGRAM

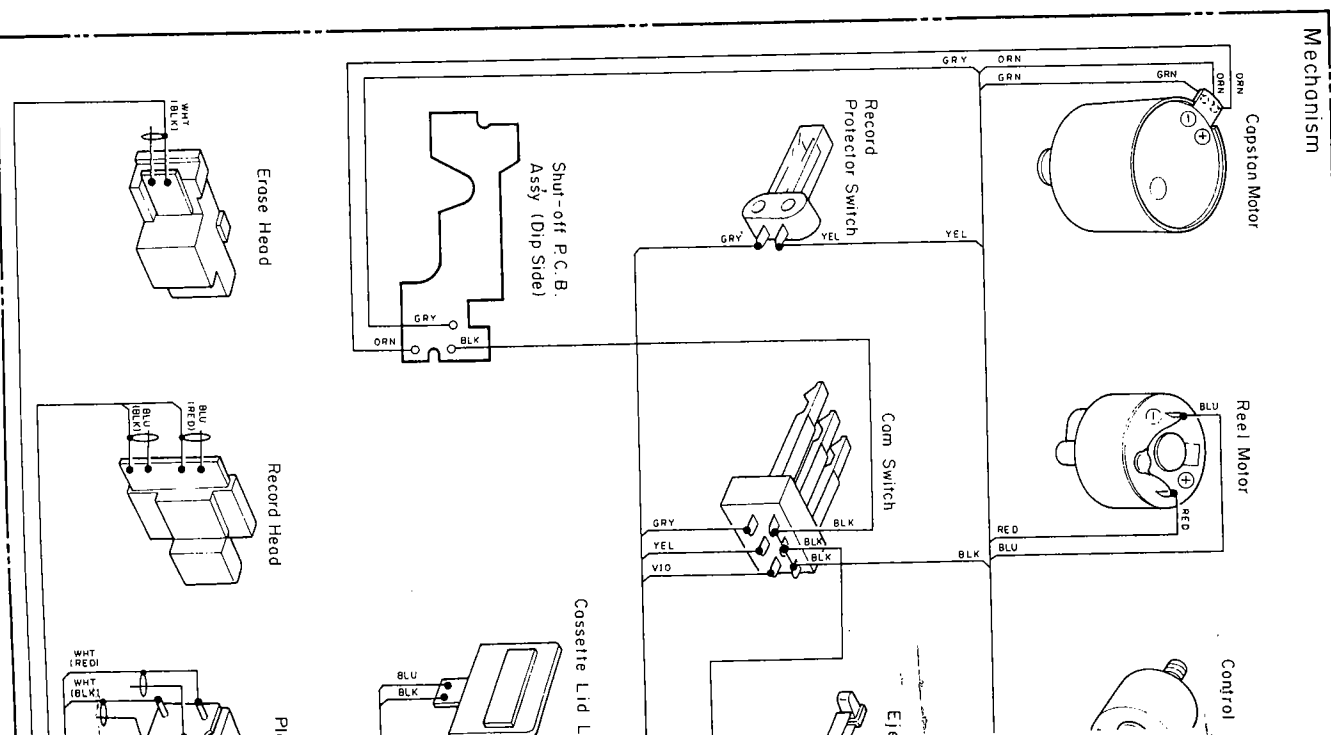
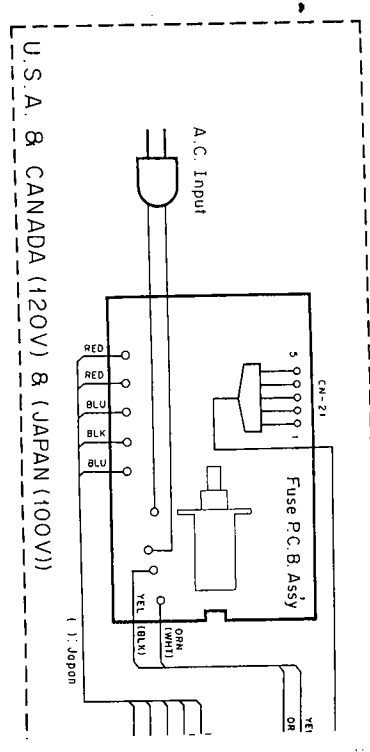
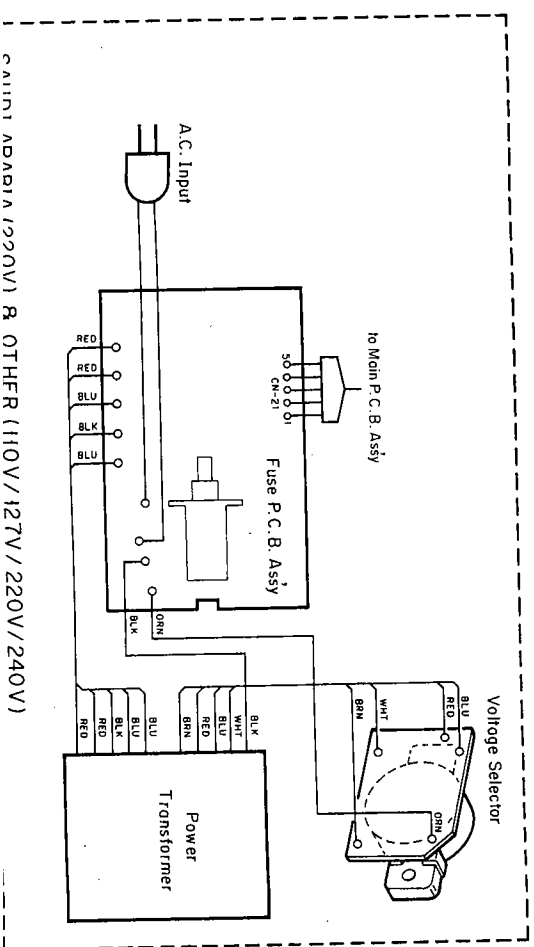
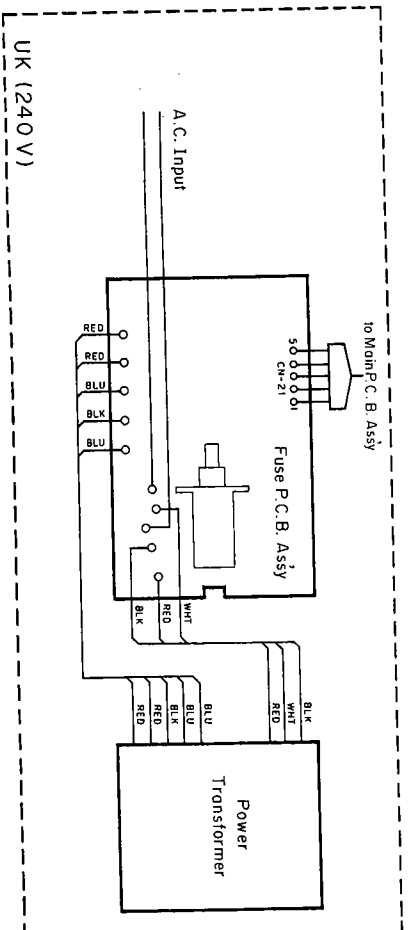
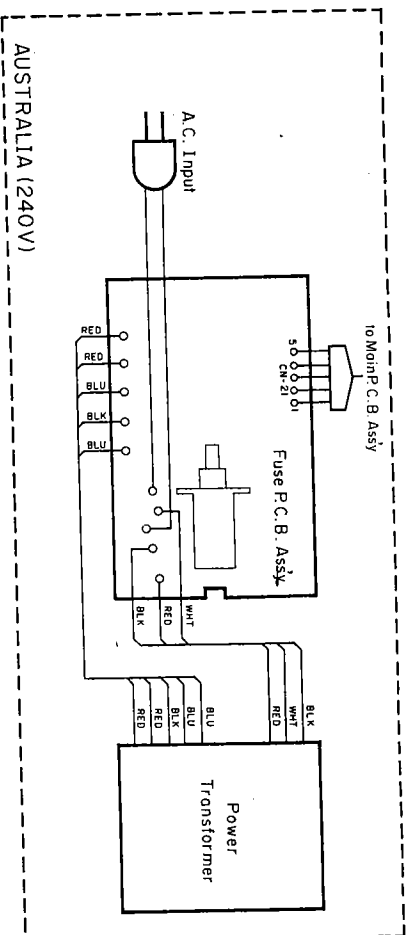
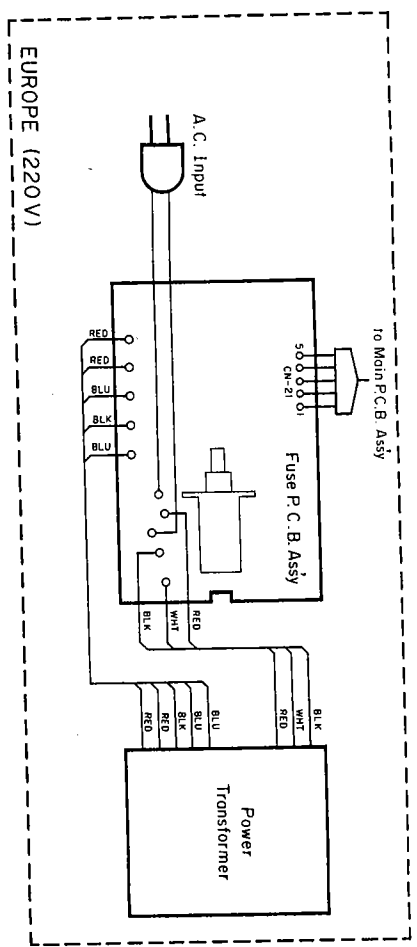

- Notes:
- Table of wire colors

BRN — Brown	BLU — Blue
RED — Red	VIO — Violet
ORN — Orange	GRY — Gray
YEL — Yellow	WHT — White
GRN — Green	BLK — Black
 - Component side view of the P.C.B. is illustrated unless otherwise specified.
 - Wire tube color is shown in ().

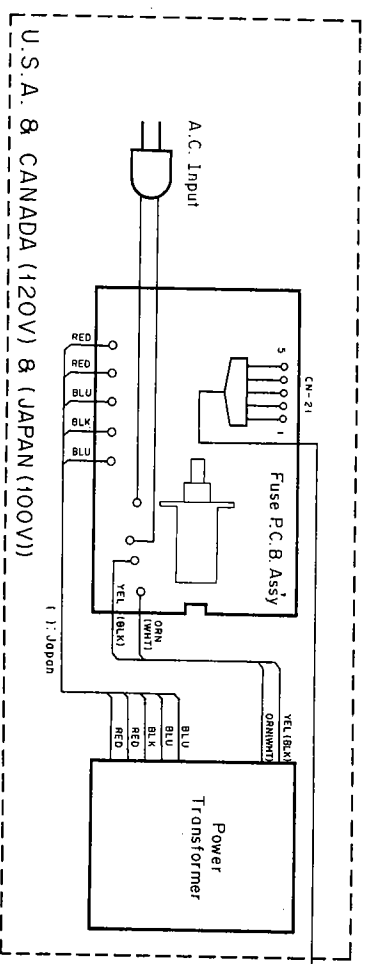

Mechanism

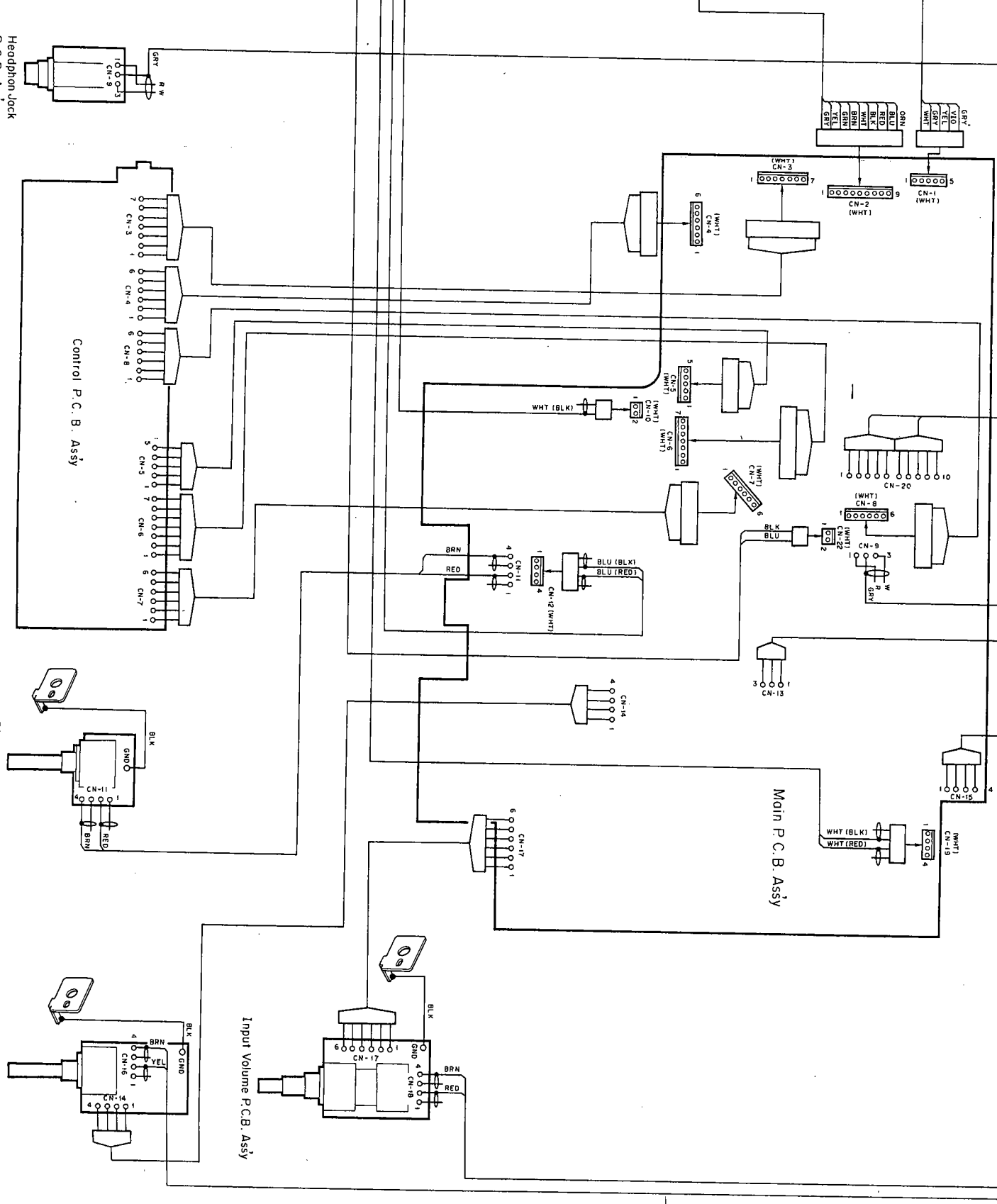
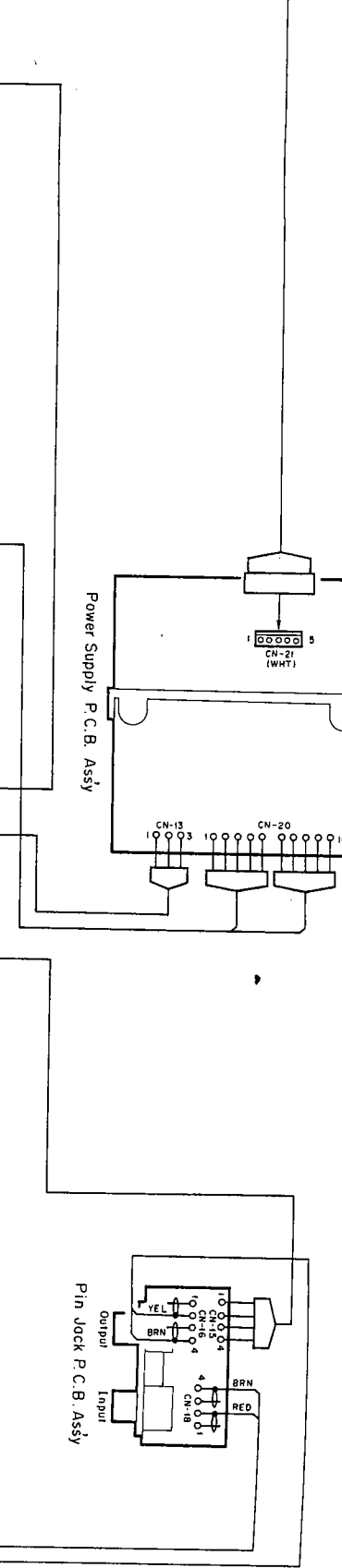
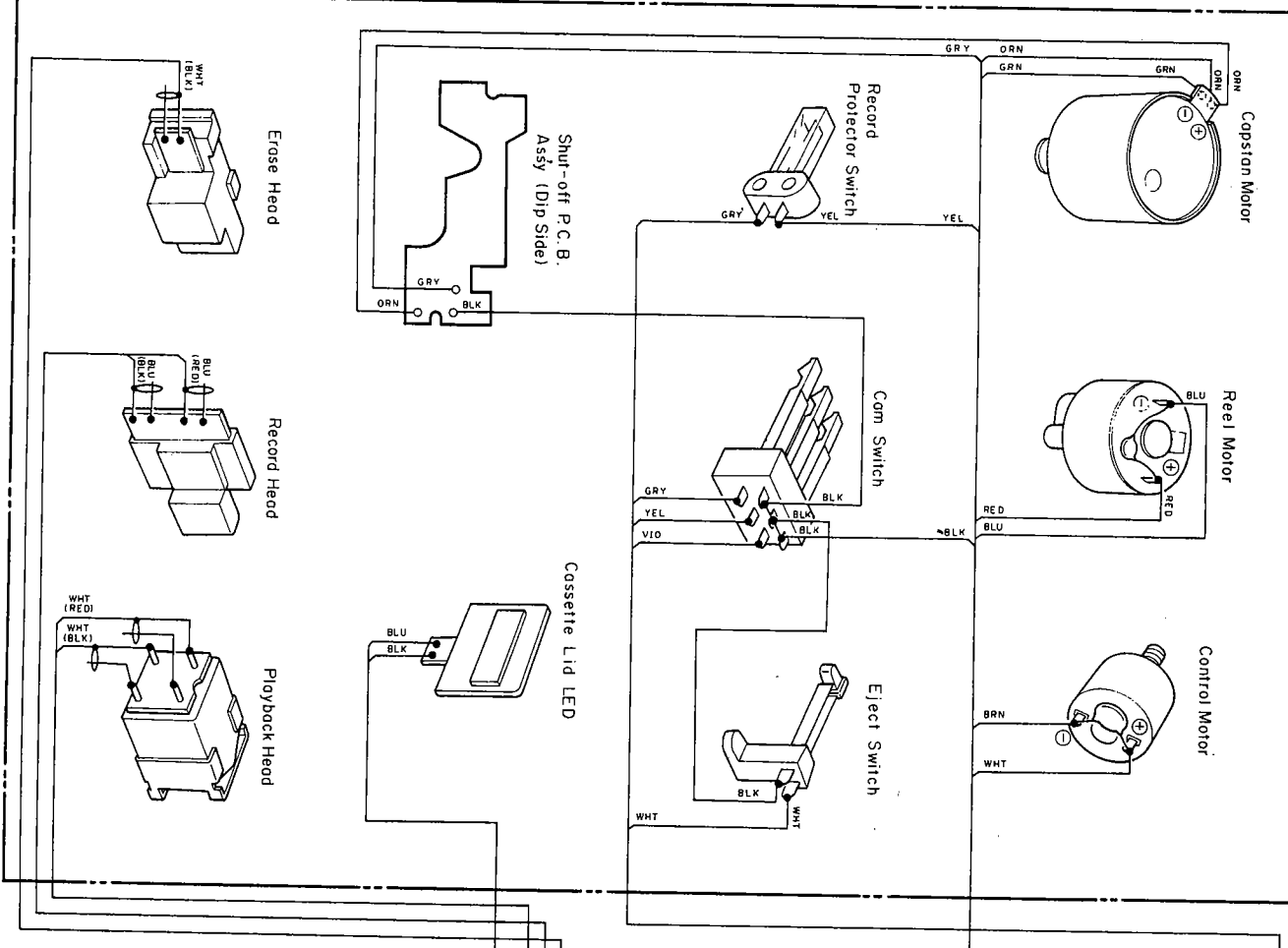

11. BLOCK DIAGRAMS

11.1. Amplifier Section

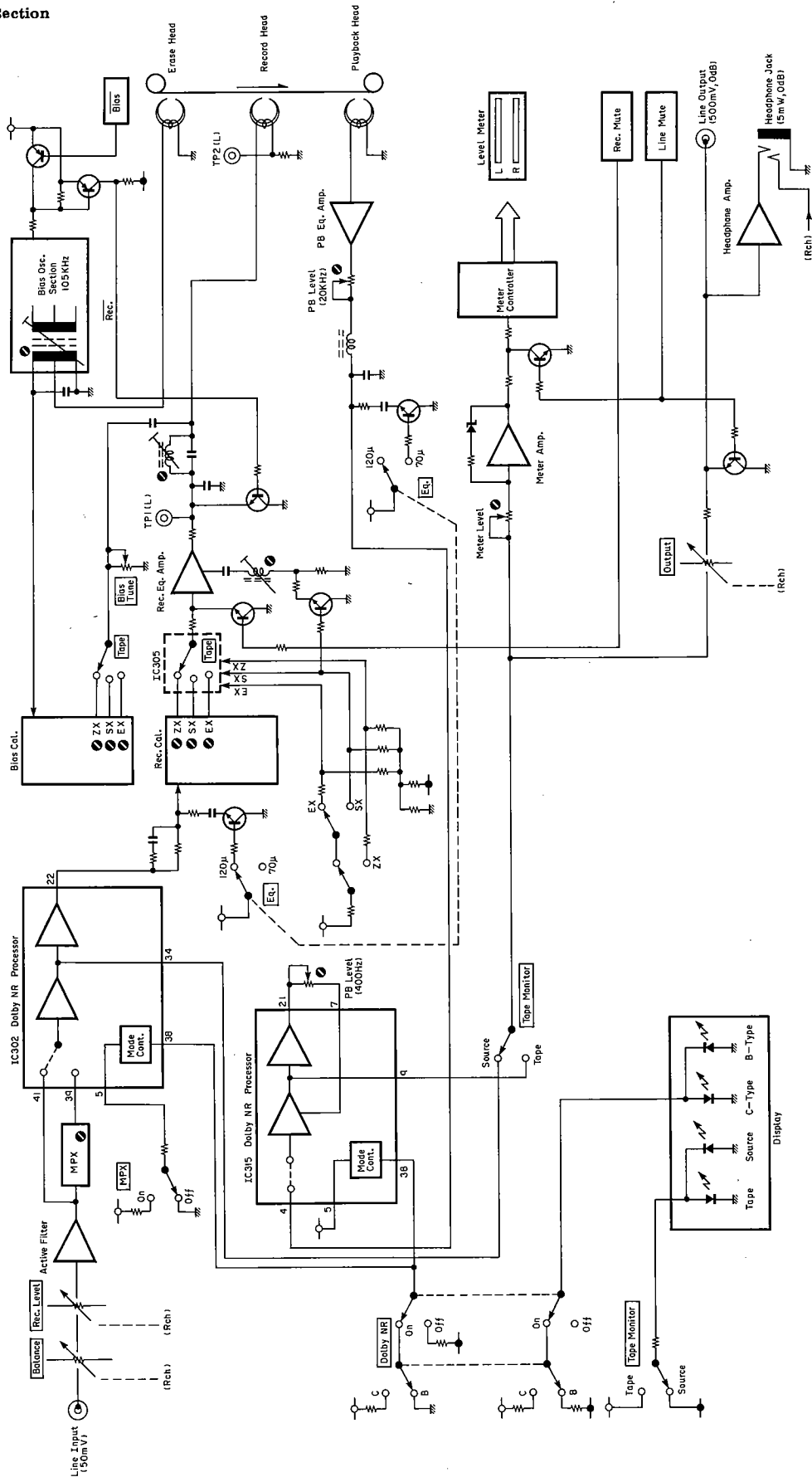

Fig. 11.1

12. TIMING CHARTS AND EQ. AMP. FREQUENCY RESPONSE

12.1. Timing Charts

(1) Overall Timing Charts

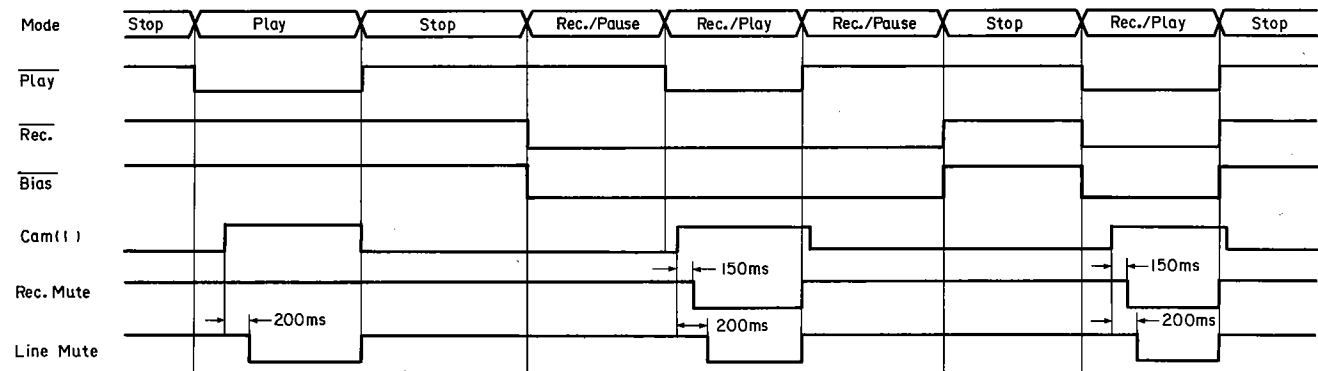

Fig. 12.1.1

(2) Mechanism Control Timing Charts

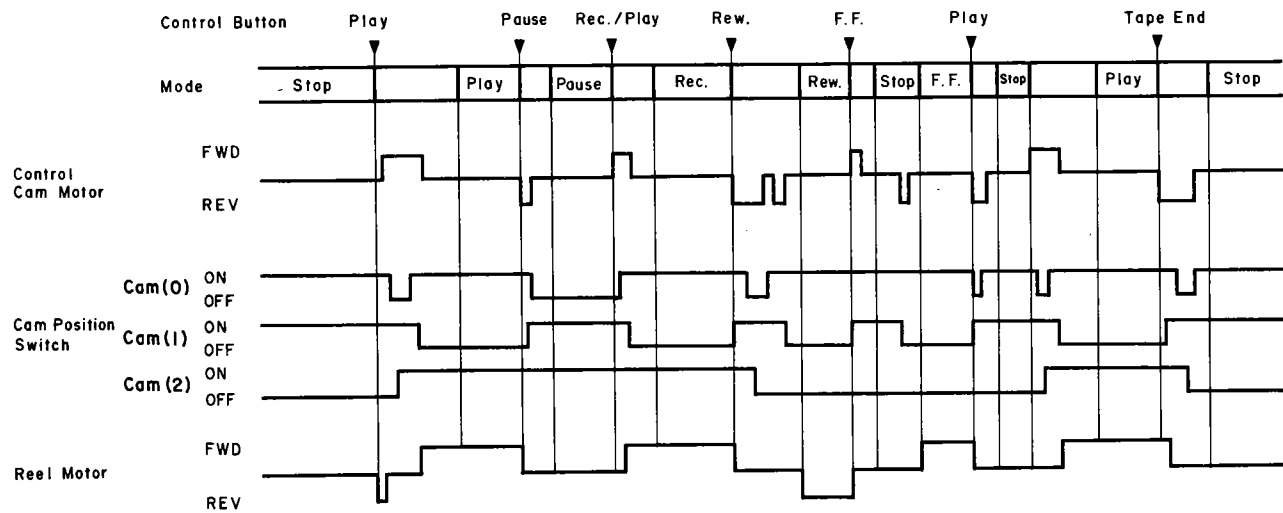

Fig. 12.1.2

12.2. Eq. Amp. Frequency Response

(1) Playback Frequency Response

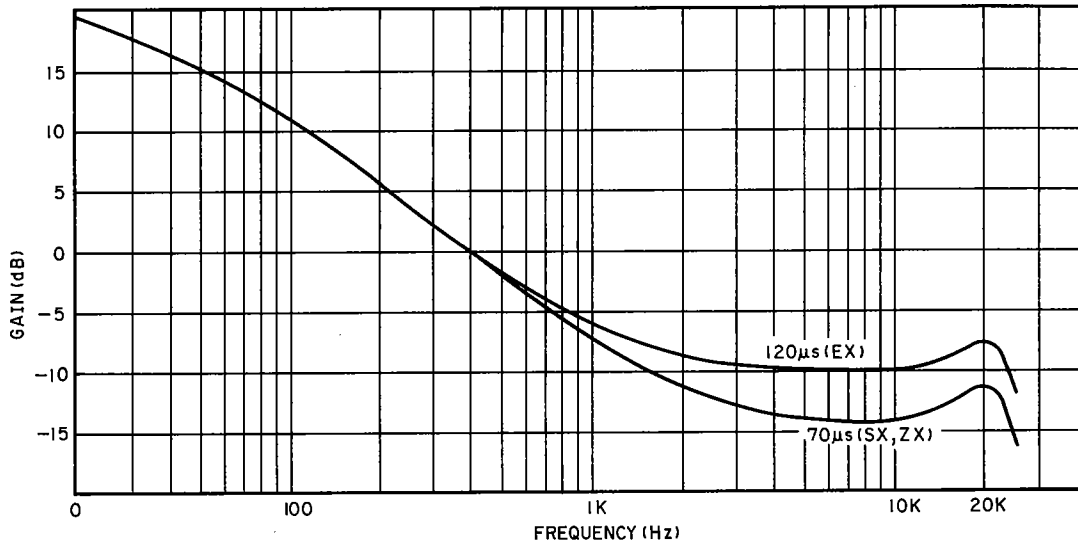

Fig. 12.2.1

(2) Record Current Frequency Response

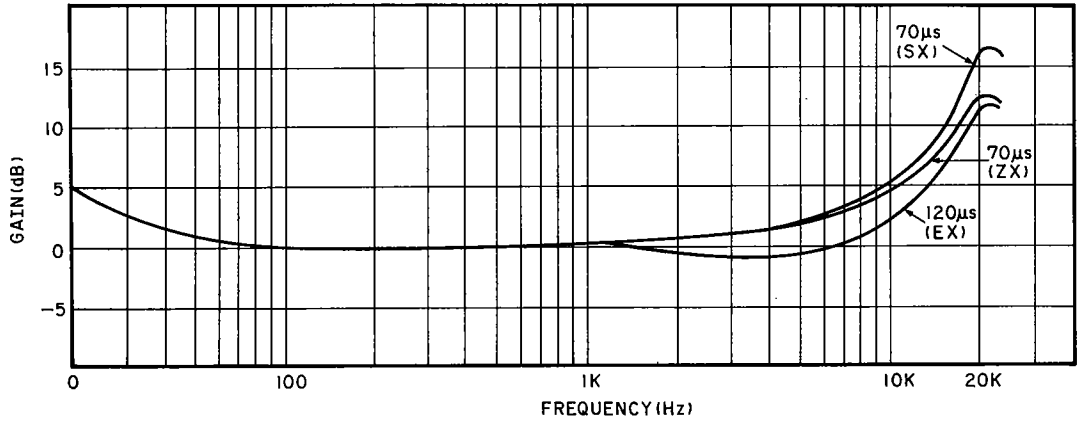

Fig. 12.2.2

13. SPECIFICATIONS

Track Configuration	4 tracks/2-channel stereo
Heads	3 (erase head x 1, record head x 1, playback head x 1)
Motors	<Tape Transport> DC Servo motor (capstan drive) x 1 DC motor (reel drive) x 1 <Mechanism> DC motor (cam drive) x 1
Power Source	120, 220, 240 or 110/127/220/240 V AC, 50/60 Hz (According to country of sale)
Power Consumption	35 W max.
Tape Speed	1-7/8 ips (4.8 cm/sec.) $\pm 0.5\%$
Wow and Flutter	Less than $\pm 0.06\%$ WTD Peak Less than 0.035% WTD RMS
Frequency Response	20 Hz—20,000 Hz ± 3 dB (recording level -20 dB, ZX [Type IV], SX [Type II], EXII [Type I] tape)
Signal to Noise Ratio	Dolby C-Type NR on $<70 \mu\text{s}$, ZX [Type IV] tape> Better than 72 dB (400 Hz, 3% THD, IHF A-WTD RMS) Dolby B-Type NR on $<70 \mu\text{s}$, ZX [Type IV] tape> Better than 66 dB (400 Hz, 3% THD, IHF A-WTD RMS)
Total Harmonic Distortion	Less than 0.9% (400 Hz, 0 dB, ZX [Type IV] tape) Less than 1.0% (400 Hz, 0 dB SX [Type II], EXII [Type I] tape)
Erasure	Better than 60 dB (100 Hz, +10 dB)
Separation	Better than 37 dB (1 kHz, 0 dB)
Crosstalk	Better than 60 dB (1 kHz, 0 dB)
Bias Frequency	105 kHz
Input (Line)	50 mV/30k ohms
Output (Line)	0.5 V (400 Hz, 0 dB, output level control at max.) 2.2k ohms
(Headphones)	5 mW into 8 ohms (400 Hz, 0 dB, output level control at max.)
Fast-Wind Time	Approx. 80 seconds (with C-60 cassette)
Dimensions	430 (W) x 100 (H) x 265 (D) mm 16-15/16 (W) x 3-15/16 (H) x 10-7/16 (D) inches
Approximate Weight	5.8 kg, 12 lbs. 13 oz

- Specifications and design are subject to change for further improvement without notice.
- Noise Reduction System manufactured under license from Dolby Laboratories Licensing Corporation.
- The word "DOLBY" and the Double-D-Symbol are trademarks of Dolby Laboratories Licensing Corporation.

Service Manual

Nakamichi

CR-3, CR-3A, CR-3E, CR-30