



Service Manual

Nakamichi

CR-4

CR-4A

CR-4E

CR-40

Discrete Head Cassette Deck

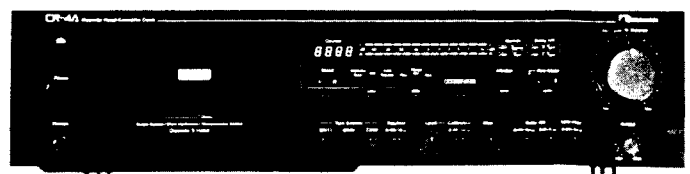

CONTENTS

1.	General	1
2.	Removal Procedures	3
2. 1.	Top Cover Ass'y and Bottom Cover Ass'y	3
2. 2.	Cassette Case Cover Ass'y	3
2. 3.	Mechanism Ass'y	3
2. 4.	Monitor Switch Joint	3
2. 5.	Front Panel	4
2. 6.	Bias P.C.B. Ass'y and Level Adjustment P.C.B. Ass'y	4
2. 7.	Control P.C.B. Ass'y	5
2. 8.	Head Mount Base	5
2. 9.	Power Switch Joint	5
3.	Test Tapes and Gauges	6
4.	Mechanical Adjustments	6
4. 1.	Record Head and Playback Head Tilt Adjustment	6
4. 2.	Head Base Stroke Check	6
4. 3.	Erase Head Stroke Adjustment and Tape Guide Height Check	7
4. 4.	Erase Head Height and Tilt Adjustment	7
4. 5.	Playback Head and Record Head Height Adjustment and Azimuth Alignment	8
4. 6.	Tape Travelling Check	8
4. 7.	Eject Damper Adjustment	8
4. 8.	Reel Motor Speed Adjustment in Play Mode	8
4. 9.	Tape Speed Adjustment	8
4. 10.	Lubrication	9
5.	Parts Location for Electrical Adjustment	10
6.	Electrical Adjustments	15
7.	Mechanism Ass'y and Parts List	15
7. 1.	Synthesis	16
7. 2.	Chassis Ass'y (A01)	16
7. 3.	Bottom Cover Ass'y (A02)	17
7. 4.	Mechanism Ass'y (B01)	17
7. 5.	Front Escutcheon Ass'y (B02)	17
7. 6.	D.D. Motor Ass'y (C01)	19
8.	Mounting Diagrams and Parts List	19
8. 1.	Fuse P.C.B. Ass'y	19
8. 2.	Pin Jack P.C.B. Ass'y	19
8. 3.	Input Volume P.C.B. Ass'y	20
8. 4.	Output Volume P.C.B. Ass'y	20
8. 5.	Headphone P.C.B. Ass'y	20
8. 6.	Level Adjustment P.C.B. Ass'y	20
8. 7.	Bias P.C.B. Ass'y	20
8. 8.	Shut-off P.C.B. Ass'y	21
8. 9.	Power Supply P.C.B. Ass'y	21
8. 10.	Cal. Osc. P.C.B. Ass'y	21
8. 11.	Flywheel Holder Ass'y	24
8. 12.	Control P.C.B. Ass'y	25
8. 13.	Main P.C.B. Ass'y	29
9.	Schematic Diagrams	29
9. 1.	IC Block Diagrams	33
9. 2.	Schematic Diagrams	35
10.	Wiring Diagram	39
11.	Block Diagrams	39
11. 1.	Amplifier Section	40
11. 2.	Mechanism Control Section	40
12.	Timing Charts and Eq. Amp. Frequency Response	40
12. 1.	Timing Charts	41
12. 2.	Eq. Amp. Frequency Response	42
13.	Specifications	

1. GENERAL

1.1. Modification History

According to change of playback/rec. equalization, Main P.C.B. Ass'y and Cal. Osc. P.C.B. Ass'y have been changed as follows:

Serial No.	Part No.	Description
A13102451 - (CR-4A)	BA07188A	Main P.C.B. Ass'y
A13153801 - (CR-4/4E/40)	BA07192A	Cal. Osc. P.C.B. Ass'y
A13101001 - 02450 (CR-4A)	BA07030A	Main P.C.B. Ass'y
A13150001 - 53800 (CR-4/4E/40)	BA07008A	Cal. Osc. P.C.B. Ass'y

1.2. Voltage Selector

Voltage selector is installed on the rear panel for Other version of the Nakamichi CR-4.

This voltage selector can select 110, 127, 220, or 240 V at customer's disposal.

1.3. Package Ass'y and Accessory Ass'y

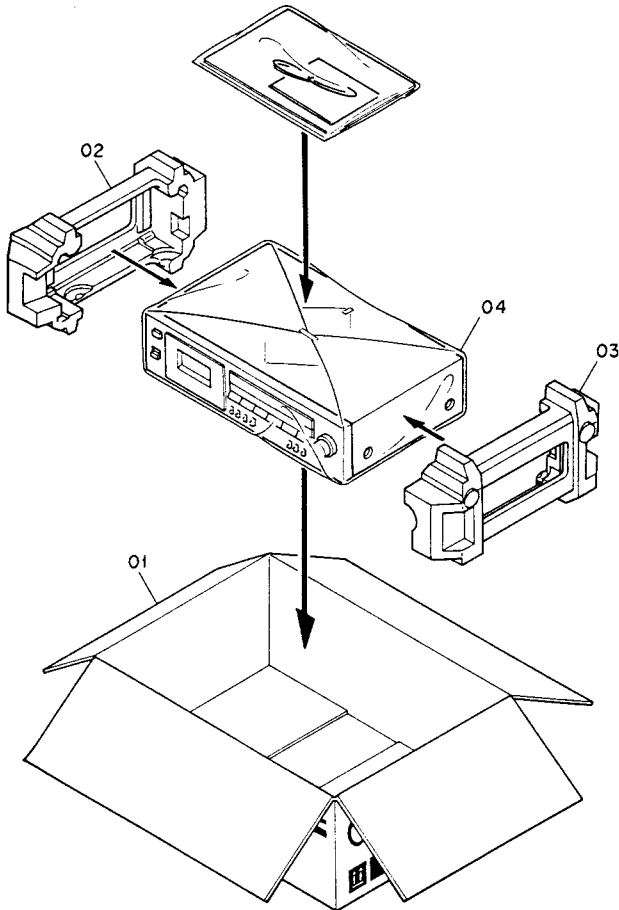

Fig. 1

Schematic Ref. No.	Part No.	Description	Qty
		Package Ass'y	
01	0F04083A	Carton Box (CR-4)	1
	0F04085A	Carton Box (CR-4A)	1
	0F04084A	Carton Box (CR-4E)	1
	0F04102A	Carton Box (CR-40)	1
02	0F04087D	Packing L	1
03	0F04088D	Packing R	1
04	0F04107A	Soft-Sheet	1
	0F04093A	Poly-Bag (CR-4A)	1
	0M05075A	Serial Number Label (CR-4, CR-4E & CR-40)	2
	0M05074A	Serial Number Label (CR-4A)	2
	0M03457A	Voltage Label 240V (CR-4 (Australia) & CR-4E (UK))	2
	0M05101A	Voltage Label 127V (CR-4 (Saudi Arabia))	2
	0M05102A	Shipping Label LOS (CR-4A)	1
	0M05103A	Shipping Label VAN (CR-4A)	1
	0M05084A	Point of Sale Label (CR-40)	1
	0D04046A	Warranty Card (CR-40)	1
	0D04047A	User's Pack (CR-40)	1
	0M05105A	LA Label (CR-4A)	2
	0M05108A	UL/Canada Label (CR-4A)	2
	0M05106A	UL Label (CR-4A)	2
	0M05107A	Canada Label (CR-4A)	2
		Accessory Ass'y	
	0D03092B	Poly-Bag	1
	0D04494A	Pin-Cord (OFC) (CR-40)	2
	0D04766A	General Catalogue (CR-4A)	1
	0D04783C	Owner's Manual (English/German/French) (CR-4, CR-4A & CR-4E)	1
	0D04784B	Owner's Manual (Japanese) (CR-40)	1
	DA04121A	Pin Cord Ass'y (CR-4, CR-4A & CR-4E)	1
	0D04796A	Tape Catalogue (CR-4A)	1
	0D04797A	Warranty Card (CR-4A)	1
	0D04810A	Important Notice	1
	0M03844B	Power Cord Label (CR-4E (UK))	1
	0D04787B	Price Card (CR-40)	1
	0D04795A	Tape Catalogue (CR-40)	1
	0D04829A	Tape Supplement	1
	0D04848A	Supplement (CR-4 (Other & Saudi Arabia))	1

2. REMOVAL PROCEDURES

2.1. Top Cover Ass'y and Bottom Cover Ass'y

Refer to Fig. 2.1.

- (1) Loosen F01 and remove F02 (Top Cover Ass'y).
- (2) Loosen F03 and remove F04 (Bottom Cover Ass'y).

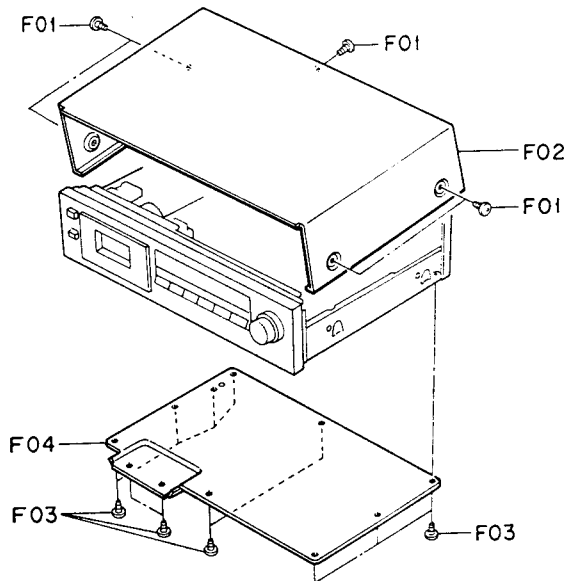

Fig. 2.1

2.2. Cassette Case Cover Ass'y

Refer to Fig. 2.2.

- (1) Press F01 (Eject Button) to open F02 (Cassette Case Cover Ass'y).
- (2) Pull F02 (Cassette Case Cover Ass'y) upward.

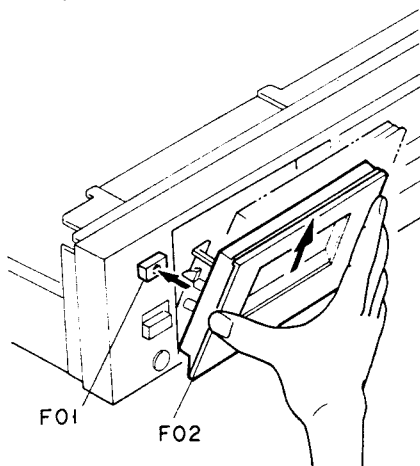

Fig. 2.2

2.3. Mechanism Ass'y

Refer to Fig. 2.3.

- (1) Remove the Top Cover Ass'y and the Bottom Cover Ass'y referring to item 2.1.
- (2) Remove the Cassette Case Cover Ass'y referring to item 2.2.
- (3) Loosen F01, cut F02 with nippers, remove F03 and F04, and disassemble F05 (Mechanism Ass'y).

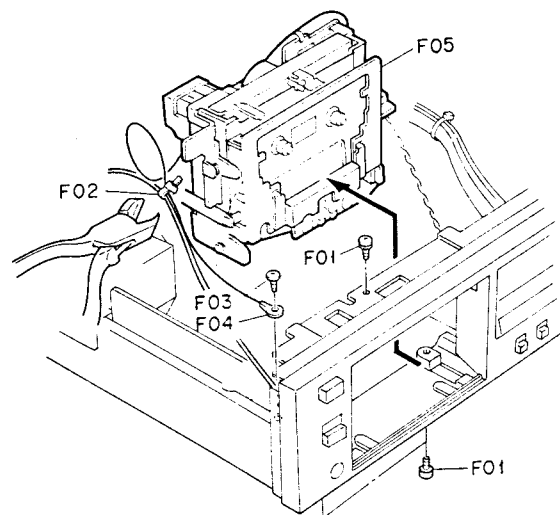

Fig. 2.3

2.4. Monitor Switch Joint

Refer to Fig. 2.4.

- (1) Remove the Top Cover Ass'y and the Bottom Cover Ass'y referring to item 2.1.
- (2) With pushing F01 (Monitor Switch Joint) in the direction of the arrow A, pull F01 (Monitor Switch Joint) in the direction of the arrow B to remove it.

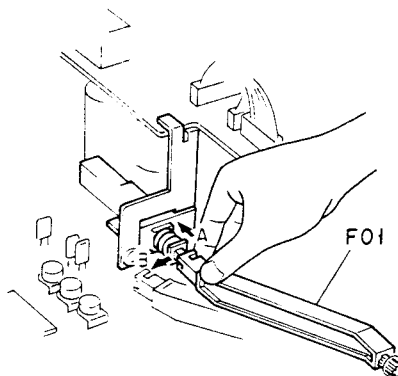

Fig. 2.4

2.5. Front Panel

Refer to Fig. 2.5.

- (1) Remove the Top Cover Ass'y and the Bottom Cover Ass'y referring to item 2.1.
- (2) Remove the Cassette Case Cover Ass'y referring to item 2.2.
- (3) Pull out F01, F02 and F03, and loosen F04 and F05.
- (4) With pushing claws by hand as shown in the figure, remove F06 (Front Panel).

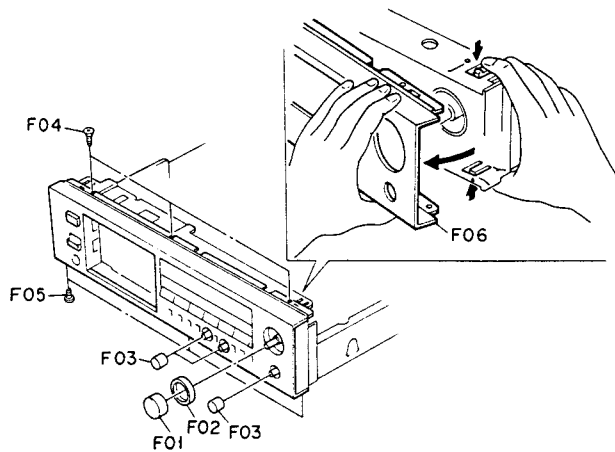

Fig. 2.5

2.6. Bias P.C.B. Ass'y and Level Adjustment P.C.B. Ass'y

(1) Move of Main P.C.B. Ass'y and Cal. Osc. P.C.B. Ass'y
Refer to Fig. 2.6.1.

- (a) Remove the Top Cover Ass'y and the Bottom Cover Ass'y referring to item 2.1.
- (b) Remove the Cassette Case Cover Ass'y referring to item 2.2.
- (c) Remove the Monitor Switch Joint referring to item 2.4.
- (d) Remove the Front Panel Ass'y referring to item 2.5.
- (e) Loosen F01 and F02, and separate F03 (Rear Panel).
- (f) Loosen F04 and F05, and move F06 (Cal. Osc. P.C.B. Ass'y) and F07 (Main P.C.B. Ass'y) rearward.

(2) Removal of Bias P.C.B. Ass'y and Level Adjustment P.C.B. Ass'y

Refer to Fig. 2.6.2.

- (a) Move F06 (Cal. Osc. P.C.B. Ass'y) and F07 (Main P.C.B. Ass'y) as described above.
- (b) Loosen F08 with a special nut driver or with pliers, and remove F09 and F10 (Bias P.C.B. Ass'y).
- (c) Loosen F11 with a special nut driver or with pliers, and remove F12 and F13 (Level Adjustment P.C.B. Ass'y).

Note: When installing the Main P.C.B. Ass'y, to facilitate installation, place the Main P.C.B. Ass'y so that the top of switches on the Main P.C.B. Ass'y come in contact with the ends of push buttons as shown in Fig. 2.7. Then fasten F01 to position the Main P.C.B. Ass'y.

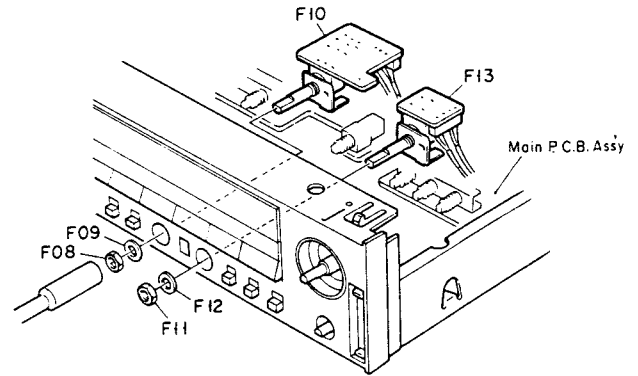

Fig. 2.6.2

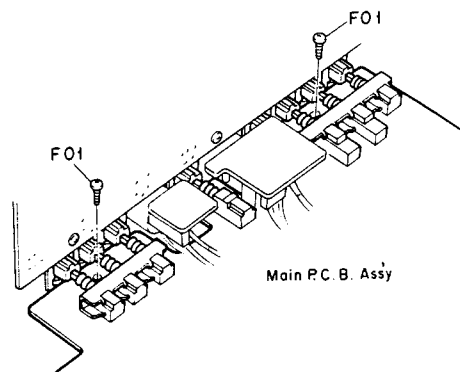

Fig. 2.7

2.7. Control P.C.B. Ass'y

Refer to Fig. 2.8.

- (1) Remove the Bias P.C.B. Ass'y referring to item 2.6.
- (2) Remove the Mechanism Ass'y referring to item 2.3.
- (3) Loosen F01, unhook F02, and remove F03 (Control P.C.B. Ass'y).

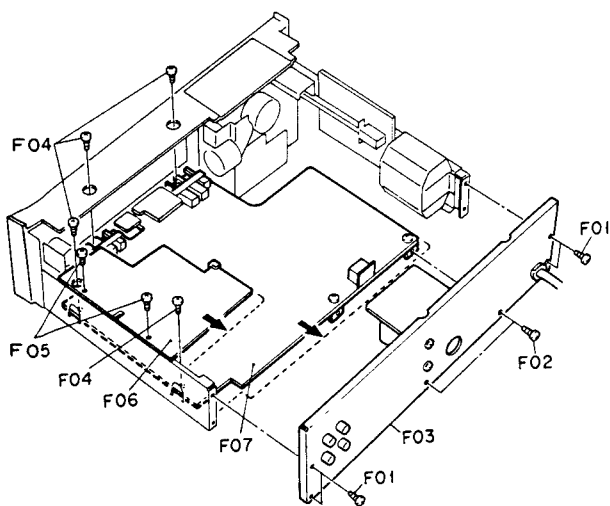

Fig. 2.6.1

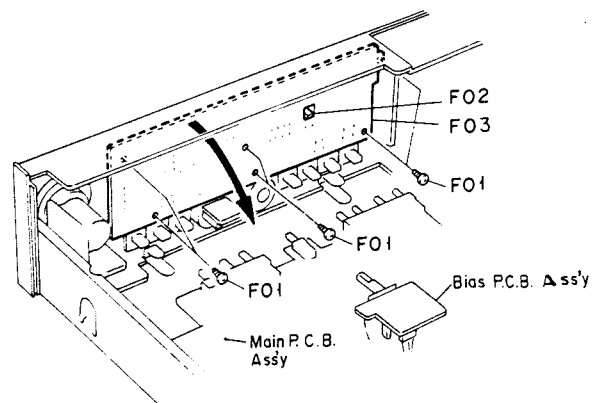

Fig. 2.8

2.8. Head Mount Base Ass'y

Refer to Fig. 2.9.

- (1) Remove the Top Cover Ass'y and the Bottom Cover Ass'y referring to item 2.1.
- (2) Remove the Mechanism Ass'y referring to item 2.3.
- (3) Loosen F01 and remove F02 (Head Mounting Cover).
- (4) Loosen F03, remove F04 and F05, straighten F06 (Wire Clamper), and lift F07 (Head Mount Base Ass'y).

Note: When mounting the Head Mount Base Ass'y, follow the next steps. Refer to Figs. 2.10.1 and 2.10.2.

- (a) Insert the Plate Washer into the groove of the shaft by hand as shown in Fig. 2.10.1.
- (b) Mount F07 (Head Mount Base Ass'y) and fasten F03. Then push the Plate Washer with a blade of screwdriver to set the Plate Washer free. Refer to Fig. 2.10.2.

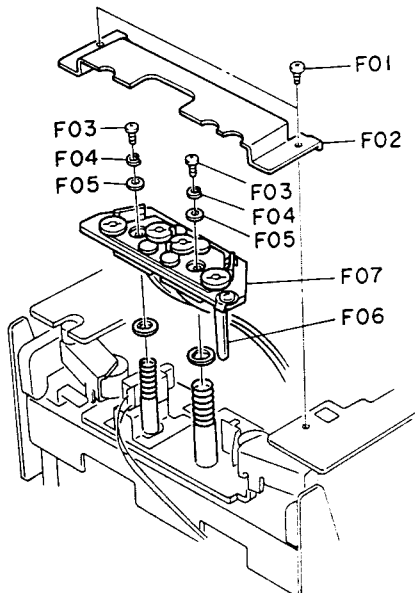

Fig. 2.9

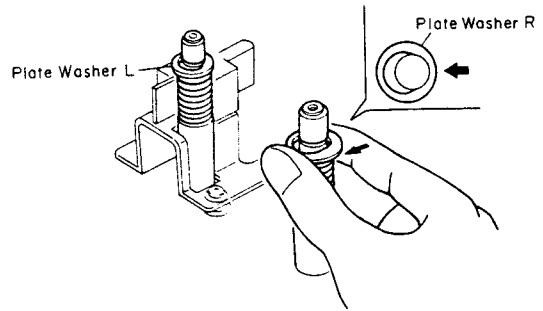

Fig. 2.10.1

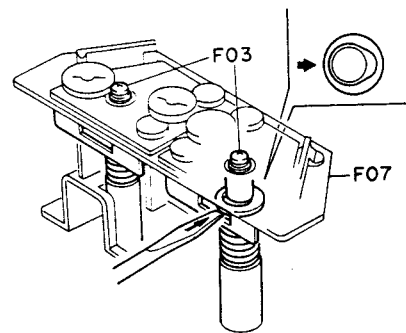

Fig. 2.10.2

2.9. Power Switch Joint

Refer to Fig. 2.11.

- (1) Remove the Top Cover Ass'y referring to item 2.1.
- (2) Pull F01 (Power Switch Joint) upward to remove it.

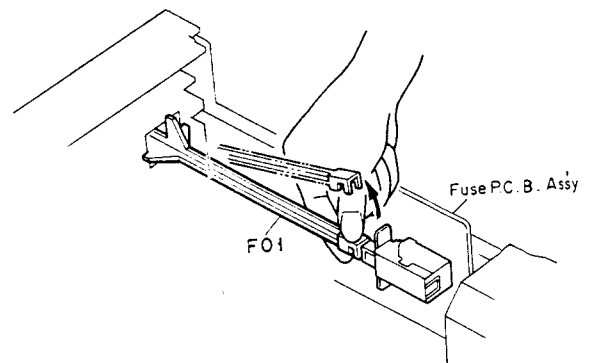

Fig. 2.11

3. TEST TAPES AND GAUGES

- (1) 400 Hz Level Tape (DA09005B)
- (2) 1 kHz Track Alignment B Tape (DA09087B)
- (3) 10 kHz PB Frequency Response Tape (DA09003B)
- (4) 15 kHz PB Frequency Response Tape (DA09002B)
- (5) 20 kHz PB Frequency Response Tape (DA09001B)
- (6) 15 kHz Azimuth Tape (DA09004B)
- (7) 3 kHz Speed and Wow/Flutter Tape (DA09006C)
- (8) Tape Travelling Cassette (DA09071A)
- (9) Reference EXII Tape (DA09111A)
- (10) Reference SX Tape (DA09110A)
- (11) Reference ZX Tape (DA09109A)
- (12) EH Tilt Check Gauge S (DA09088A)
- (13) Stroke Check Gauge S (DA09090A)
- (14) Tape Guide Height Check Gauge S (DA09091A)
- (15) Tilt Check Gauge S (DA09039B)
- (16) Torque Gauge FWD (DA09082A)

4. MECHANICAL ADJUSTMENTS

4.1. Record Head and Playback Head Tilt Adjustment

Remove the Cover Plate Ass'y by loosening two screws to gain access to the head block.

Refer to Fig. 4.1.

- (1) Remove the pad lifter from the playback head.
- (2) Load a Tilt Check Gauge S (DA09039B) in the cassette deck.
- (3) Clip the grounding terminal of the Tilt Check Gauge with one end of the cord with clip, and the chassis of the cassette deck with the other end.
- (4) Remove both of the Height Gears.
- (5) Set the cassette deck in Play mode. Check to insure whether the Beacons Playback Head "Upper" or "Lower" and Record Head "Upper" or "Lower" are illuminating. In order not to give damages onto the head surfaces, push both of slide knobs of the Gauge to away from the heads, then return them to the original place to be in contact with record head and playback head surfaces after Play mode is securely locked.
- (6) Beacon Playback Head "Lower" will light on when height adjustment screw (PH) turned counterclockwise but playback Head "Upper" when clockwise. Adjust so that both "Upper" and "Lower" will light on even when you move the slide knob away from the heads and then return it to the original place.
- (7) Same procedures will apply to the Beacons Record Head "Upper" and "Lower", except for the height adjustment screw (RH).
- (8) Set the cassette deck in Stop mode and fit both of the serrated Height Gears. Then set the cassette deck again in Play mode and insure all of the 4 Beacons are illuminating. If not, (4) through (7) will have to be repeated till satisfactory results are obtained.
- (9) Mount the pad lifter on the playback head.

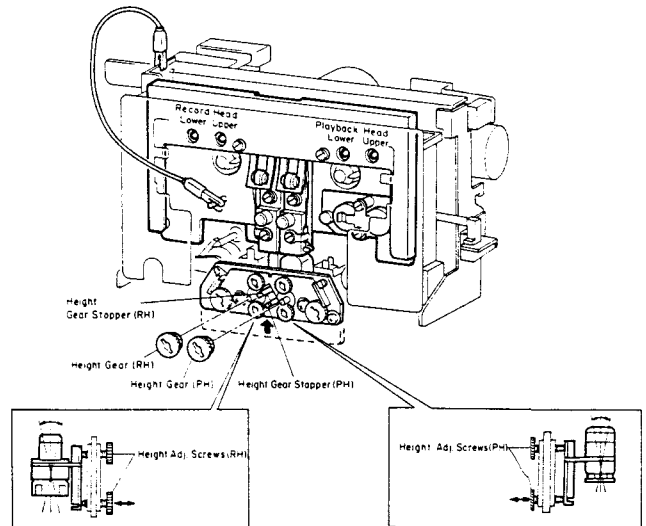

Fig. 4.1

4.2. Head Base Stroke Check

Remove the Cover Plate Ass'y.

Refer to Fig. 4.2.

Note: Before you conduct this adjustment, adjust with a "Tilt Check Gauge S" to insure freedom from tilt on the playback head and record head.

- (1) Load a Stroke Check Gauge S (DA09090A) in the cassette deck.
- (2) Move Record Head Indicator and Playback Head Indicator to the direction of arrow mark "A" with your finger tip and then set the cassette deck in Play mode. Then slowly release the Indicators and insure whether each of the Indicators is in contact with record and playback heads.
- (3) Check to insure whether the line "P" on the Playback Head Indicator meets the central line on the Indicator Plate.
- (4) Check to insure whether the line "P" on the Playback Head Indicator locates between the 2 lines on the Record Head Indicator, thus check can be made on record head stroke.

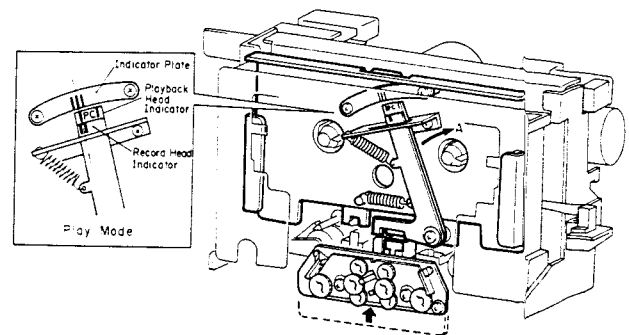

Fig. 4.2

4.3. Erase Head Stroke Adjustment and Tape Guide Height Check

Remove the Cover Plate Ass'y and the Head Mount Base Ass'y.

Refer to Fig. 4.3.

- (1) Erase Head Stroke Adjustment
 - (a) Load a Tape Guide Height Check Gauge S (DA09091A) in the cassette deck.
 - (b) Set the cassette deck in Play mode, thus check can be made on erase head stroke through the EH Stroke Indicator.
 - (c) Check to insure whether the erase head surface is aligned with red line on the EH Stroke Indicator. If not, adjust the erase head stroke by loosening screw A that assembles erase head with erase head plate.
 - (d) After completion of adjustment, screw A shall be locked with lock tight paint.
- (2) Supply Tape Guide Height Adjustment
 - (a) Load a Tape Guide Height Check Gauge S (DA09091A) in the cassette deck.
 - (b) Set the cassette deck in Play mode.
 - (c) Slide the Supply Tape Guide Check Bar down against the supply tape guide, and check to insure that the Supply Tape Guide Check Bar is accepted by the supply tape guide. If not, adjust the supply tape guide height by turning screw B.
- (3) Take-up Tape Guide Height Check
 - (a) Load a Tape Guide Height Check Gauge S (DA09091A) in the cassette deck.
 - (b) Set the cassette deck in Play mode.
 - (c) Slide the Take-up Tape Guide Check Bar down against the take-up tape guide, and check to insure that the Take-up Tape Guide Check Bar is accepted by the take-up tape guide.

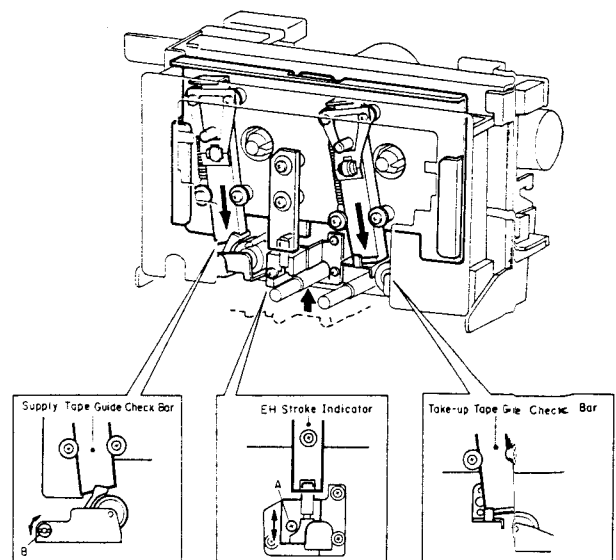

Fig. 4.3

4.4. Erase Head Height and Tilt Adjustment

Refer to Fig. 4.4.

- (1) Remove the Cassette Case Cover Ass'y, Cover Plate Ass'y, and Head Mount Base Ass'y.
- (2) Load an EH Tilt Check Gauge S (DA09088A) in the cassette deck.
- (3) Set the cassette deck in Stop mode.
- (4) Check to insure whether one of the 3 Beacons is illuminating. Look down the mirror and slowly turn the Screw "Height" counterclockwise (or clockwise) so that the two horizontal lines on the mirror will become superposed on the line (in different color) of the erase head, and check to insure whether the first Beacon is illuminating.
- (5) Turn Screw "Tilt" counterclockwise (or clockwise) to light on the second Beacon. Excessive turning will cause the first

- Beacon to light off. Adjustments of Screw "Tilt" will therefore be conducted till both of the first and the second Beacons illuminate.
- (6) Turn Screw "Azimuth" counterclockwise (or clockwise) to light on the third Beacon. Excessive turning will cause either the first or the second Beacon to light off, and therefore adjust Screw "Azimuth" until all of the 3 Beacons illuminate.
- (7) Check to insure whether the horizontal line on the mirror corresponds to that on the erase head. If not, (4) through (7) will have to be repeated till satisfactory results are obtained.
- (8) After completion of adjustment, 3 pcs. of screws shall be locked with lock tight paint.

Note: Before use of this gauge, check to insure freedom from dust or dirt, or overflow in the groove of the erase head surface.

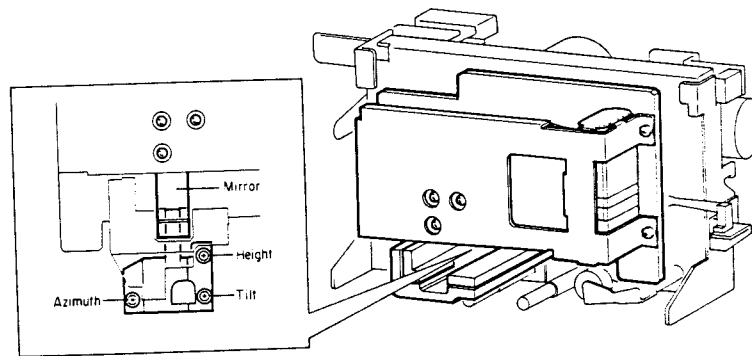

Fig. 4.4

4.5. Playback Head and Record Head Height Adjustment and Azimuth Alignment

Refer to Fig. 4.5.

- (1) Playback Head Height Adjustment and Azimuth Alignment
 - (a) Set the Monitor switch to Tape and connect an AC voltmeter to the Output Jacks.
 - (b) Load a 1 kHz Track Alignment B Tape (DA09087B) and set the cassette deck in Play mode.
 - (c) Turn the PH Height Gear until the outputs of both channels become minimum.
 - (d) Load a 15 kHz Azimuth Tape (DA09004B) and set the cassette deck in Play mode.
 - (e) Turn the PH Azimuth Alignment Screw until the outputs of both channels become maximum.
 - (f) Repeat above steps (b) through (e) two or three times to obtain optimum performance.

- (2) Record Head Height Adjustment and Azimuth Alignment
 - (a) Set the cassette deck in Stop mode.
 - (b) Set the Monitor switch to Tape, Eq. switch to 70 μ s and Tape Selector switch to ZX.
 - (c) Load a reference ZX tape and connect an AC voltmeter to Output Jacks.
 - (d) Feed in 400 Hz (0 dB) to the Input Jacks.
 - (e) Set the cassette deck in Record and Play mode and turn the RH Height Gear until the outputs of both channels become maximum.
 - (f) Feed in 15 kHz (-20 dB) to the Input Jacks and turn the RH Azimuth Alignment Screw until the outputs of both channels become maximum.
 - (g) Repeat (d) to (f) two or three times to obtain optimum performance.

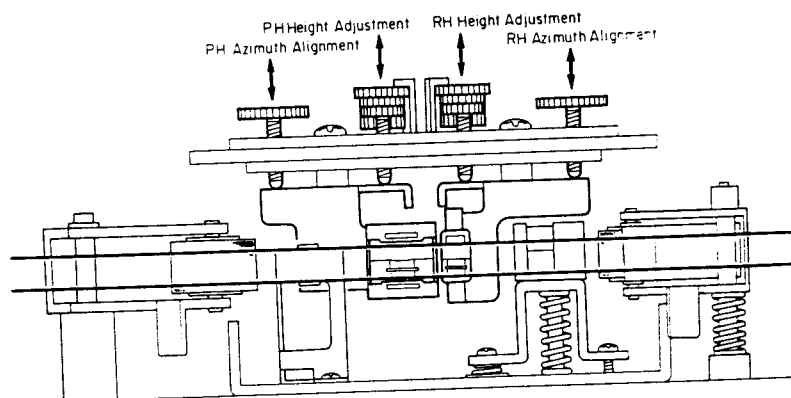

Fig. 4.5

4.6. Tape Travelling Check

Load and play back a Tape Travelling Cassette and check the following:

- (1) Tape is in contact with heads sufficiently.
- (2) Tape waving is small on the heads and pressure rollers.
- (3) Tape is free from waving or slippage from the tape guides.

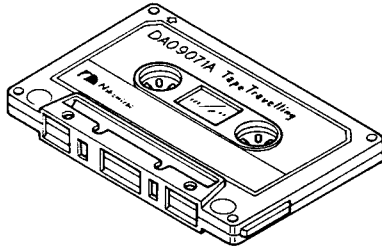

Fig. 4.6

4.7. Eject Damper Adjustment

Refer to Fig. 4.7. Load a cassette tape, and with opening the Cassette Case by pressing the Eject button and closing it by hand, adjust the speed of damper action by the Adjustment Screw.

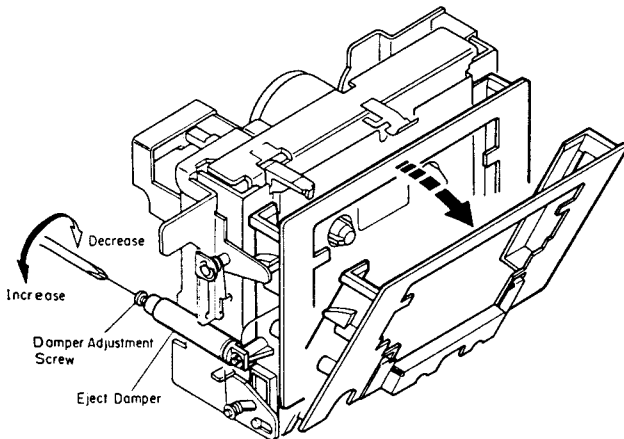

Fig. 4.7

4.8. Reel Motor Speed Adjustment in Play Mode

- (1) To warm-up the cassette deck, load a C-60 cassette tape and set the cassette deck in Play mode.
- (2) After more than four minutes, load a Torque Gauge FWD (DA09082A) and set the cassette deck in Play mode.
- (3) Adjust VR601 on the Main P.C.B. Assy to obtain exactly 50 g-cm on the torque gauge.

4.9. Tape Speed Adjustment

Refer to Fig. 4.8.

- (1) Connect a frequency counter to the Output Jacks.
- (2) Load a 3 kHz Speed and Wow/Flutter Tape (DA09006C) and play it back.
- (3) Adjust the Tape Speed Adjustment Volume incorporated in the Capstan Motor to obtain 3,000 Hz on the frequency counter.

CCW: Motor drives slowly.

CW: Motor drives fast.

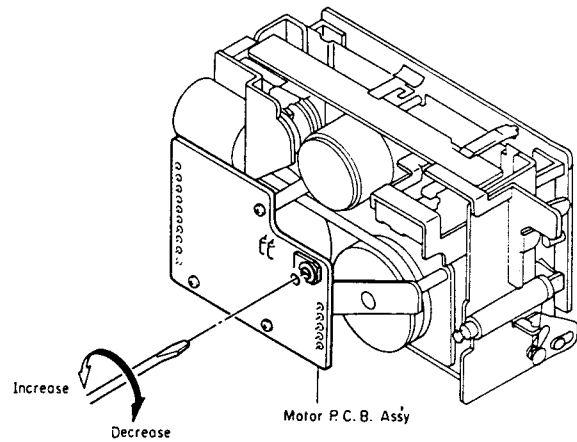

Fig. 4.8

4.10. Lubrication

The tape transport is of a lubrication-free type mechanism. When the following parts are replaced, apply the specified lubricant.

- (1) Molykote (R) Grease (X5-6020)
Cam Motor Pulley
Thrust portion on the Capstan Shaft
- (2) FLOIL GB-TS-1
Washer between Reel Hub Ass'y and Back Tension Spring
- (3) Diamond Oil (EP-56)
Reel Hub Shaft
- (4) Anderol 456
Capstan Shaft

Note: We suggest that you use the above specified lubricant or equivalent type.

The company dealing in the above lubricant is as follows:

- (a) Molykote (R) Grease (X5-6020)
Dowcoming Co., Ltd., 1-15-1 Nishishinbashi, Minato-ku, Tokyo, Japan
- (b) FLOIL GB-TS-1
Kanto Chemicals Co., Ltd., 2-7 Kanda Sakuma-cho, Chiyoda-ku, Tokyo, Japan
- (c) Diamond Oil (EP-56)
Mitsubishi Oil Co., Ltd., 1-2-4 Toranomom, Minato-ku, Tokyo, Japan
- (d) Anderol 456
Toyo Kokusai Oil Co., Ltd., 3-3-5 Hatchobori, Chuo-ku, Tokyo, Japan

5. PARTS LOCATION FOR ELECTRICAL ADJUSTMENT

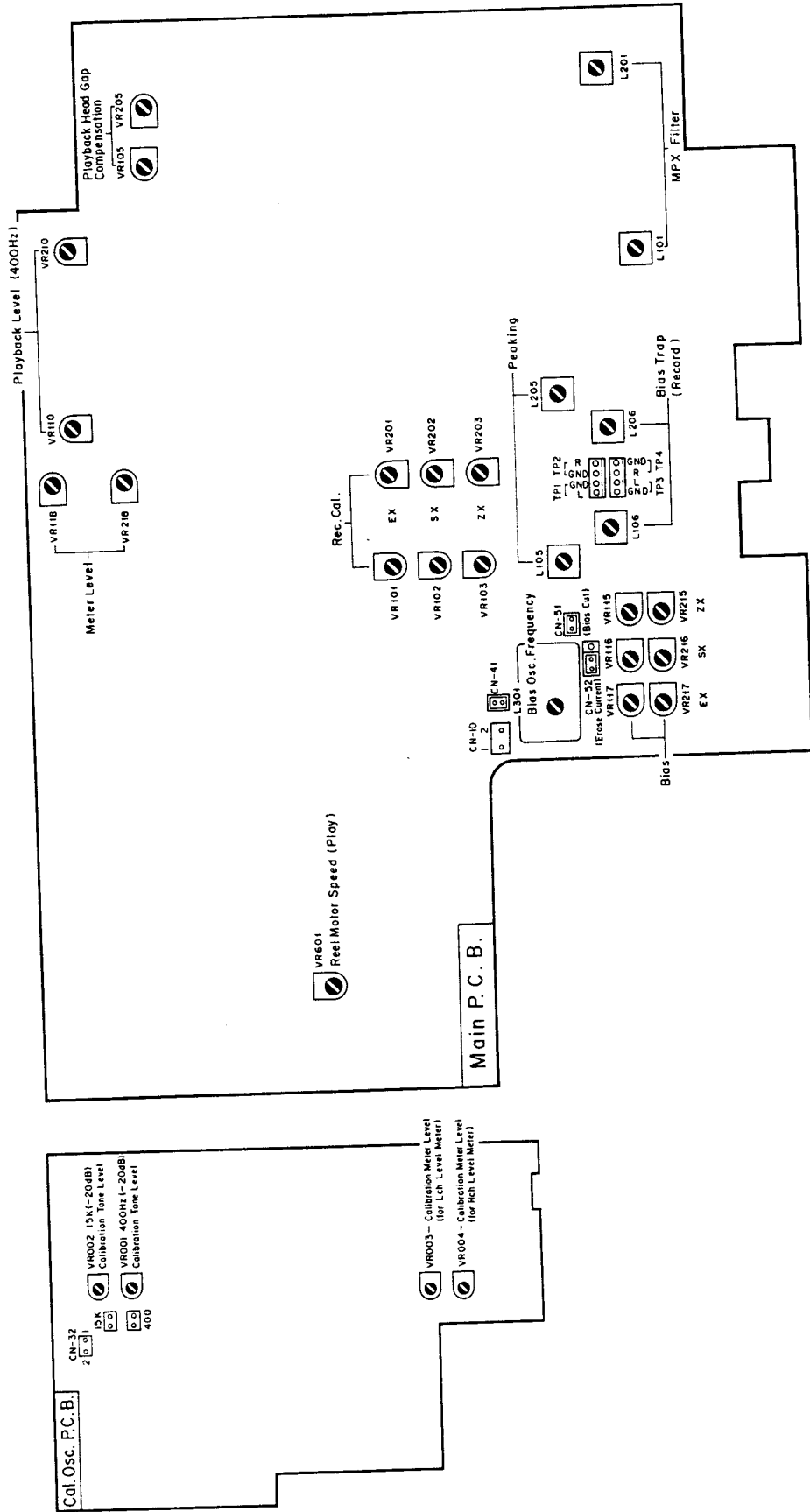
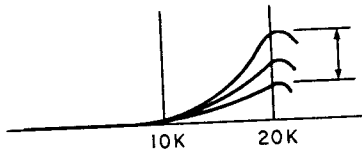



Fig. 5

6. ELECTRICAL ADJUSTMENTS

STEP	ITEM	SIGNAL SOURCE	OUTPUT CONNECTION	MODE	ADJUSTMENT	REMARKS
1	Preliminary Step			Output Level - Max. Balance - Center Bias Cal. - Center Level Cal. - Center Calibration - OFF Monitor - Tape Eq. - 70 μ s Tape - ZX MPX Filter - OFF Dolby NR - OFF		Set the CR-4/4A/4E/40 as shown in MODE.
2	Reel Motor Speed Adjustment (Play)	Torque Guage FWD (DA09082A)		Playback	Main VR601	Adjust VR601 to obtain 50 g-cm on the Torque Gauge. Refer to item 4.8.
3	Tape speed Adjustment	3 kHz Speed and Wow/Flutter Tape (DA09006C)	Frequency Counter to Output Jacks	Playback Monitor - Tape Eq. - 120 μ s	Tape Speed Adj. Volume (Capstan Motor)	Adjust the volume incorporated in the Capstan Motor Ass'y to obtain 3 kHz \pm 15 Hz on the frequency counter. Refer to item 4.9.
4	Meter Level Calibration	400 Hz to Input Jacks	AC Voltmeter to Output Jacks	Monitor - Source	Main P.C.B. VR118 VR218	1. Feed in 400 Hz and adjust the Input Level control to obtain 500 mV -2 dB on the AC voltmeter. 2. Adjust VR118 (VR218) so that the 0 dB segment on the level meter starts illuminating.
5	MPX Filter Adjustment	19 kHz \pm 100 Hz to Input Jacks	AC Voltmeter to Output Jacks	Monitor - Source MPX - OFF/ON	Main P.C.B. L101 L201	1. Adjust the Input Level control to obtain 500 mV (0 dB) on the AC voltmeter. 2. Set the MPX Filter switch to ON and adjust L101 (L201) to obtain minimum reading on the AC voltmeter. (The minimum reading will be less than -30 dB.)
6	Playback Head Track Alignment	1 kHz Track Alignment Tape (DA09087A)	AC Voltmeter to Output Jacks	Playback Monitor - Type Eq. - 70 μ s Dolby NR - OFF	PH Height Gear	Adjust the PH Height Gear to obtain the minimum readings on the AC voltmeter for both channels. Refer to "Playback Head Height Adjustment" in item 4.5.
7	Playback Head Azimuth Alignment	15 kHz Azimuth Tape (DA09004B)	AC Voltmeter to Output Jacks	Same as above	Playback Head Azimuth Alignment Screw	Adjust the Playback Head Azimuth Alignment Screw to obtain maximum readings on the AC voltmeter for both channels. Refer to "Playback Head Height Adjustment and Azimuth Alignment" in item 4.5. Note: Repeat Steps 6 and 7 two or three times to obtain optimum performance.

STEP	ITEM	SIGNAL SOURCE	OUTPUT CONNECTION	MODE	ADJUSTMENT	REMARKS
8	Playback Level Calibration	400Hz Level Tape (DA09005B)	AC Voltmeter to Output Jacks	Playback Monitor - Tape Eq. - 70 μ s Dolby NR - OFF	Main P.C.B. VR110 VR210	Adjust VR110 (VR210) to obtain 500 mV on the AC voltmeter.
9	Playback Head Compensation	400Hz Level Tape (DA09005B) 10 kHz PB Frequency Response Tape (DA09003B) 15 kHz PB Frequency Response Tape (DA09002B) 20 kHz PB Frequency Response Tape (DA09001B)	AC Voltmeter to Output Jacks	Same as above	Main P.C.B. VR105 VR205	<ol style="list-style-type: none"> Load a 400 Hz level tape, play it back, and read the playback level on the AC voltmeter. Load 10 kHz, 15 kHz and 20 kHz PB frequency response tapes and adjust the playback head azimuth to obtain maximum levels on the AC voltmeter with each tape. Check that the playback levels are as follows with respect to the level for 400 Hz level tape. 10 kHz: -20 dB -2 dB to +2 dB 15 kHz: -20 dB -2 dB to +3 dB 20 kHz: -20 dB -2 dB to +4 dB If the levels are out of the ranges, play back the 20 kHz PB frequency response tape and adjust VR105 (VR205) to obtain -20 dB +1.0 dB. VR105 (VR205) compensates the playback frequency response at 20 kHz as shown below:  <ol style="list-style-type: none"> Conduct Step 7 "Playback Head Azimuth Alignment".
10	Bias Oscillation Frequency and Erase Current Adjustment	None	AC Voltmeter across the additional 0.1 ohm resistor and Frequency Counter between terminals 1 and 2 of CN-10 on Main P.C.B.	Record, Playback Monitor - Source Tape - ZX Eq. - 70 μ s Dolby NR - OFF	Main P.C.B. L301 R344 R345	<ol style="list-style-type: none"> Connect an additional 0.1 ohm resistor in series to the Erase Head and connect the AC voltmeter across the resistor. Record and playback a reference ZX tape. Adjust L301 to obtain 105 kHz on the frequency counter. Check the erase current by the AC voltmeter. Erase current will be within the range of 310 mA to 400 mA (typically approx. 350 mA). If erase current is less than 310 mA, plug the 2P-receptacle into CN-52 as shown below to short-circuit either R344 or R345. <div style="display: flex; justify-content: space-around; align-items: center;"> <div style="text-align: center;">  <p>CN-52 (Front)</p> </div> <div style="text-align: center;"> <p>R345 (22-ohm) shorted.</p> </div> <div style="text-align: center;">  <p>CN-52 (Front)</p> </div> <div style="text-align: center;"> <p>R344 (10-ohm) shorted.</p> </div> </div> <ol style="list-style-type: none"> After completion of the erase current adjustment, re-check the bias oscillation frequency. Remove the additional 0.1 ohm resistor.

STEP	ITEM	SIGNAL SOURCE	OUTPUT CONNECTION	MODE	ADJUSTMENT	REMARKS
11	Record Amplifier Equalizer Adjustment	23 kHz (-20 dB) to Input Jacks	AC Voltmeter across both pins of TP3 (TP4) on Main P.C.B.	Record, Playback Monitor - Source Tape - ZX Eq. - 70 μ s Dolby NR - OFF	Main P.C.B. L105 L205	1. Remove the 2P-receptacle from CN-51 to stop the bias oscillation. 2. Adjust L105 (L205) to obtain approx. 16 dB at 23 kHz on the AC voltmeter. 3. Plug the 2P-receptacle into CN-51.
12	Bias Trap Adjustment (Record Amp.)	Remove input signals	AC Voltmeter across both pins of TP1 (TP2) on Main P.C.B.	Same as above	Main P.C.B. L106 L206	Adjust L106 (L206) to obtain minimum reading on the AC voltmeter.
13	Record Head Height Adjustment	400 Hz (0 dB) to Input Jacks	AC Voltmeter to Output Jacks	Record, Playback Monitor - Tape Tape - ZX Eq. - 70 μ s Dolby NR - OFF	RH Height Gear	1. Load a reference ZX tape, and record and play it back. 2. Adjust the RH Height Gear to obtain maximum readings for both channels on the AC voltmeter. Refer to "Record Head Height Adjustment and Azimuth Alignment" in item 4.5.
14	Record Head Azimuth Alignment	15 kHz (-20 dB) to Input Jacks	AC Voltmeter to Output Jacks	Same as above	Record Head Azimuth Alignment Screw	Adjust the Record Head Azimuth Alignment Screw to obtain maximum readings for both channels on the AC voltmeter. Refer to "Record Head Height Adjustment and Azimuth Alignment" in item 4.5. Note: Repeat Steps 13 and 14 two or three times to obtain optimum performance.
15	Record Level Calibration and Recording Bias Current Adjustment	400 Hz (0 dB), 15 kHz (-20 dB) and 10 kHz/20 kHz (-20 dB) to Input Jacks	AC Voltmeter to Output Jacks	Record, Playback Monitor - Source/Tape ZX/SX/EX Eq. - 70 μ s (ZX/SX) 120 μ s (EX) Dolby NR - OFF/B/C	Main P.C.B. (Level) ZX:VR103 VR203 SX:VR102 VR202 EX:VR101 VR201 (Bias) ZX:VR115 VR215 SX:VR116 VR216 EX:VR117 VR217	Adjustment should be made in the order of ZX, SX and EX. 1. Set the Monitor switch to Source. 2. Feed in 400 Hz, and set the Input Level control to obtain 0 dB (500 mV) on the AC voltmeter. 3. Set the Monitor switch to tape. 4. Load a reference ZX tape, reference SX tape and reference EXII tape. 5. Set Record Cal. VR103 (VR203) for ZX, VR102 (VR202) for SX and VR101 (VR201) for EXII tape to their center position. 6. Adjust Bias VR115 (VR215) for ZX, VR116 (VR216) for SX and VR117 (VR217) for EXII tape to obtain maximum reading on the AC voltmeter. 7. Feed in 15 kHz (-20 dB) and adjust Bias VR115 (VR215), VR116 (VR216) and VR117 (VR217) to obtain the same readings as source monitor level; on the AC voltmeter. (to be continued)

STEP	ITEM	SIGNAL SOURCE	OUTPUT CONNECTION	MODE	ADJUSTMENT	REMARKS
						<p>8. Feed in 400 Hz (0 dB) and adjust Record Cal. VR103 (VR203), VR102 (VR202) and VR101 (VR201) to obtain 0 dB (500 mV) on the AC voltmeter.</p> <p>9. Repeat above 7 and 8 two or three times to obtain optimum performance.</p> <p>10. Feed in 10 kHz and 20 kHz (-20 dB), record and play them back, and check whether the playback levels are within the following ranges.</p> <p>With Dolby NR OFF: -20 dB \pm3 dB Level difference between Dolby NR OFF and B: \pm2 dB Level difference between Dolby NR OFF and C: \pm3 dB</p> <p>11. Check that the total harmonic distortion is less than 0.8% for ZX tape and 1.0% for SX and EXII tapes. If satisfactory results are not obtained, re-adjust VR105 (VR205) referring to Step 9 "Playback Head Gap Compensation" and repeat above steps.</p>
16	Overall Frequency Response Adjustment	400 Hz (0 dB) and 20 Hz to 20 kHz (-20 dB) to Input Jacks	AC Voltmeter to Output Jacks	Record, Playback Monitor - Source/Tape Tape - ZX/SX/EX Eq. - 70 μ s (ZX/SX) 120 μ s (EX) Dolby NR - OFF	Main P.C.B. L105 L205	<p>1. Set the Monitor switch to Source.</p> <p>2. Feed in 400 Hz and adjust the Input Level control to obtain -20 dB on the AC voltmeter.</p> <p>3. Set the Monitor switch to Tape.</p> <p>4. Feed in 20 Hz to 20 kHz (-20 dB) and check to insure whether the output levels are within -20 dB \pm3 dB.</p> <p>5. If above is not sufficient, adjust L105 (L205) to obtain approx. -20 dB at 20 kHz.</p> <p>6. Conduct step 15 "Record Level Calibration and Recording Bias Current Adjustment".</p> <p>7. If above is not sufficient, precise re-adjustment of step 9 "Playback Head Gap Compensation", replacement of Playback Head or Record Head, check on item 4.6 "Tape Travelling Check" will be required.</p>

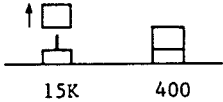
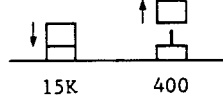
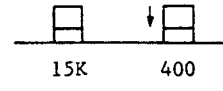
STEP	ITEM	SIGNAL SOURCE	OUTPUT CONNECTION	MODE	ADJUSTMENT	REMARKS
17	Calibration Tone Level and Meter Level Adjustment	400 Hz (0 dB)	AC Voltmeter to Output Jacks	Record, Playback Monitor - Tape Tape - ZX Eq. - 70 μ s Dolby NR - OFF Calibration - OFF/ON Timer - OFF Memory Stop/Auto Repeat - Memory Stop	Cal. Osc. P.C.B. VR001 (400Hz) VR002 (15kHz) VR003 (Lch) VR004 (Rch)	<ol style="list-style-type: none"> Make sure that the Bias Calibration and Level Calibration controls are at their center positions. Set the Timer switch to OFF and the Memory Stop/Auto Repeat switch to Memory Stop. Press the Reset button to clear the tape counter. Feed in 400 Hz, record and play it back, and adjust the Input Level control to obtain 500 mV (0 dB) on the AC voltmeter. Set the Calibration switch to ON and pull out the connector CN-32 on the Cal. Osc. P.C.B. Ass'y to cut mute output signals. Remove the 2P-receptacle from the connector "15K (15 KHz)" on the Cal. Osc. P.C.B. Ass'y.  <ol style="list-style-type: none"> Adjust VR001 to obtain 400 Hz -20 dB (50 mV) on the AC voltmeter. Remove the 2P-receptacle from the connector "400 (400 Hz)" and plug the 2P-receptacle into the connector "15K (15 kHz)" on the Cal. Osc. P.C.B. Ass'y.  <ol style="list-style-type: none"> Adjust VR002 to obtain 15 kHz -20 dB (50 mV) on the AC voltmeter. Plug the 2P-receptacle into the connector "400 (400 Hz)".  <ol style="list-style-type: none"> Plug the CN-32 into the original place. Load a reference ZX tape, and record and play it back. Adjust VR003 so that the 0 dB segment of the Lch level meter comes ON. Adjust VR004 so that the 0 dB segment of the Rch level meter comes ON. Turn OFF the Calibration switch and check that the tape is automatically rewound and stops at the tape counter "0000".

7. MECHANISM ASS'Y AND PARTS LIST

7.1. Synthesis

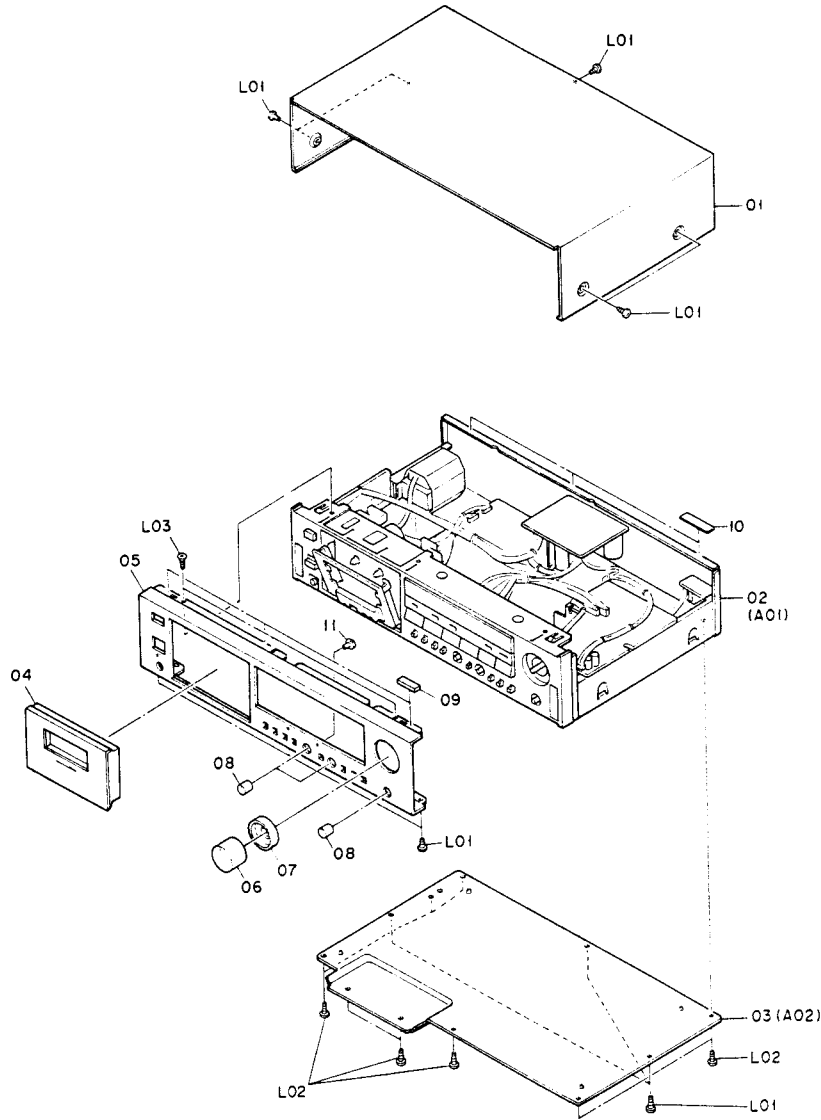

Fig. 7.1

Schematic Ref. No.	Part No.	Description	Q'ty	Schematic Ref. No.	Part No.	Description	Q'ty
7.1. Synthesis				L02	0E00921A	BT3x8 ⊕ Binding (Black Chromate)	8
Synthesis Serial No.: A13101001 -				L03	0E03054A	BT3x8 ⊕ Countersunk	3
01	OH05111A	Top Cover	1	—	OJ05460A	Adhesive Tape for LED Lens	1
02	—	Chassis Ass'y	1	—	OM03797A	Voltage Seal 240V (CR-4E (UK))	1
03	JA04339A	Bottom Cover Ass'y (CR-4 & CR-4E)	1	—	OM03844B	Power Cord Label (CR-4E (UK))	1
	JA04338A	Bottom Cover Ass'y (CR-4A)	1	—	OM03917A	Production Date Seal (CR-4A)	1
04	HA05348A	Cassette Case Cover Ass'y	1	—	OM04381A	EP Approval Label (CR-4E (Europe))	1
05	OH05278A	Front Panel (CR-4)	1	—	OM04811A	Voltage Caution Sheet (CR-4 (Other & Saudi Arabia))	1
	OH05167A	Front Panel (CR-4A)	1	—	OM05065A	Pass Label (CR-4A)	1
	OH05280A	Front Panel (CR-4E)	1	—	OM05067A	CSA Approval Label (CR-4A (Canada))	1
	OH05279A	Front Panel (CR-40)	1	—	OM05068A	LA Label (CR-4A (U.S.A.))	1
06	HA05340A	Rec. Volume Knob Ass'y	1	—	OM05075A	Serial Number Seal (CR-4, CR-4E & CR-40)	1
07	HA05338A	Rec. Balance Knob Ass'y	1	—	OM05074A	Serial Number Seal (CR-4A)	1
08	HA05339A	Bias Volume Knob Ass'y	3	—	OM05077A	Voltage Caution Label 127V (CR-4 (Saudi Arabia))	1
09	OJ05453A	Top Cover Cushion	3	—	OM05111A	F. Mark Approval Seal (CR-4E (Europe))	1
10	OJ05407A	Top Cover Sheet	3	—	OM05116A	Amp. Number Seal	1
11	OH05103A	LED Lens B	11	—	MA01001A	F. Code Labels (CR-4, CR-4E & CR-40)	1
L01	0E03433A	BT3x6 ⊕ Binding Projected (Black Chromate)	11	—			

7.2. Chassis Ass'y (A01)

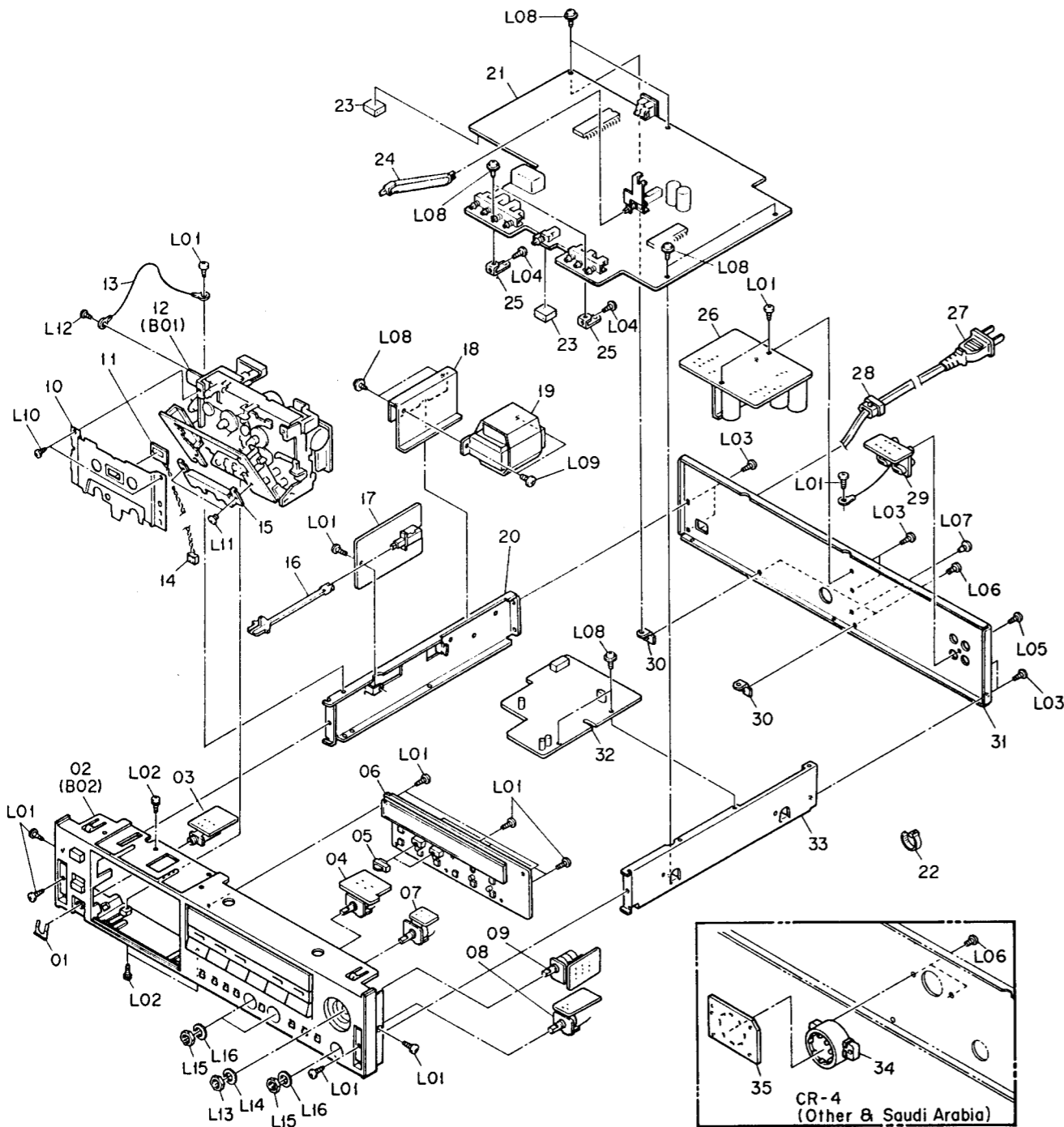
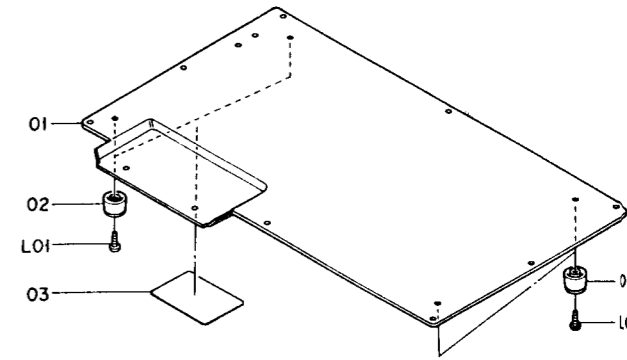

Fig. 7.2

Schematic Ref. No.	Part No.	Description	Q'ty	Schematic Ref. No.	Part No.	Description	Q'ty
7.2. Chassis Ass'y (A01)							
A01	—	Chassis Ass'y Serial No.: A13101001 -	1	L08	OE03432A	BT3x6 @ Tapping (Black Chromate)	10
01	OJ05427A	Mount Plate	1	L09	OE03438A	ST4x6 @ Binding	2
02	HA05342A	Front Escutcheon Ass'y	1	L10	OE03437A	BT2.5x3.5 @ Fan (Black Chromate)	2
03	BA07052A	Headphone P.C.B. Ass'y (CR-4, CR-4A, CR-4E (UK) & CR-40) (Europe)	1	L11	OE03202A	M2.6x3 @ Binding (Black Chromate)	2
04	BA07011A	Bias P.C.B. Ass'y	1	L12	OE00859A	BT2.6x6 @ Binding	1
05	OH05095A	Slide Button	2	L13	OE03375A	Nut Hex. M9	1
06	BA07042A	Control P.C.B. Ass'y	1	L14	OE03376A	Washer 9mm	1
07	BA07010A	Level Adjustment P.C.B. Ass'y	1	L15	OE03382A	Nut Hex. M7	3
08	BA07051A	Output Volume P.C.B. Ass'y	1	L16	OE03383A	Washer 7mm	3
09	BA07054A	Input Volume P.C.B. Ass'y	1	—	OB80142A	Wire (CR-4 (Other & Saudi Arabia))	1
10	OH05166A	Cover Plate	1	—	OJ05462A	BS Damper 15x30 (CR-40)	2
11	OB12580A	LED P Green SLF-7250	1	—	OJ05463A	BS Damper 15x60 (CR-40)	1
12	CA08889A	Mechanism Ass'y	1	—	OJ05464A	P.C.B. Cushion B (CR-40)	1
13	OB83255A	GND Wire Ass'y	1	—	OM05112A	Fuse Caution Label (CR-4A)	1
14	OB83132A	2P Connector	1	7.3. Bottom Cover Ass'y (A02)			
15	OH04415B	Head Mounting Cover	1	A02	JA04339A	Bottom Cover Ass'y (CR-4 & CR-4E)	1
16	OJ05402A	Power Switch Joint	1	—	JA04338A	Bottom Cover Ass'y (CR-4A)	1
17	BA07045A	Fuse P.C.B. Ass'y (CR-4 & CR-4E)	1	—	JA04341A	Bottom Cover Ass'y (CR-40) Serial No.: A13101001 -	1
18	BA07044A	Fuse P.C.B. Ass'y (CR-4A)	1	01	OJ05454A	Bottom Cover	1
19	BA07046A	Fuse P.C.B. Ass'y (CR-40)	1	02	OJ05420A	Leg N (CR-4, CR-4A & CR-4E)	4
20	OJ05417C	Transformer Holder	1	03	HA05357A	Leg Ass'y (CR-40)	4
21	OB50100A	Power Transformer (CR-4 (Australia) & CR-4E)	1	L01	OM04377B	Caution Label (CR-4A)	1
—	OB50101A	Power Transformer (CR-4 (Other & Saudi Arabia))	1	—	OE00888A	BT3x12 @ Binding	4
—	OB50099A	Power Transformer (CR-4A)	1	—	OJ05461A	Leg Felt (CR-4, CR-4A & CR-4E)	4
—	OB50102A	Power Transformer (CR-40)	1	7.3. Bottom Cover Ass'y (A02)			
22	BA07188A	Main P.C.B. Ass'y Serial No.: A13102451 - (CR-4) Serial No.: A13153801 - (CR-4, CR-4E & CR-40) Serial Nos.: A13150001 - 53800 (CR-4, CR-4E & CR-40)	1				
23	OB8515A	Insu-Lock SKB80	21	Fig. 7.3			
24	OJ05451A	P.C.B. Cushion	2				
25	OJ05403A	Monitor Switch Joint	1				
26	OJ05394A	P.C.B. Holder Front	2				
27	BA07041A	Power Supply P.C.B. Ass'y	1				
—	OB05241A	Power Cord (CR-4 (Australia))	1				
—	OB08533A	Power Cord (CR-4 (Other & Saudi Arabia))	1				
—	OB90294A	Power Cord (OFC) (CR-4A)	1				
—	OB08093U	Power Cord (CR-4E (Europe))	1				
—	OB08348A	Power Cord (CR-4E (UK))	1				
—	OB90293A	Power Cord (OFC) (CR-40)	1				
28	OB90280A	Cord Bushing	1				
29	BA07055A	Pin Jack P.C.B. Ass'y	1				
30	OJ05395A	P.C.B. Holder Rear	2				
31	OH05172A	Rear Panel (CR-4 (Australia))	1				
—	OH05174A	Rear Panel (CR-4 (Other & Saudi Arabia))	1				
—	OH05171B	Rear Panel (CR-4A)	1				
—	OH05173A	Rear Panel (CR-4E)	1				
—	OH05175A	Rear Panel (CR-40)	1				
32	BA07192A	Cal. Osc. P.C.B. Ass'y Serial No.: A13102451 - (CR-4) Serial No.: A13153801 - (CR-4, CR-4E & CR-40)	1				
—	BA07008B	Cal. Osc. P.C.B. Ass'y Serial Nos.: A13101001 - 02450 (CR-4A) Serial Nos.: A13150001 - 53800 (CR-4, CR-4E & CR-40)	1				
33	OJ05455A	Side Chassis R	1				
34	OB81771A	Voltage Selector (CR-4 (Other & Saudi Arabia))	1				
35	OB60503A	Voltage Selector P.C.B. (CR-4 (Other & Saudi Arabia))	1				
L01	OE00868A	BT3x8 @ Binding	15				
L02	OE03212A	BT2.6x6 @ Binding with Toothed Lock	3				
L03	OE03433A	BT3x6 @ Binding Projected (Black Chromate)	6				
L04	OE00846A	BT3x8 @ Pan	2				
L05	OE00921A	BT3x8 @ Binding (Black Chromate)	1				
L06	OE00985A	M3x6 @ Binding (Black Chromate) (CR-4 (Australia) & CR-4A, CR-4E & CR-40)	2				
—	OE00985A	M3x6 @ Binding (Black Chromate) (CR-4 (Other & Saudi Arabia))	4				
L07	OJ05108A	Hole Plug No.9	1				

7.4. Mechanism Ass'y (B01)

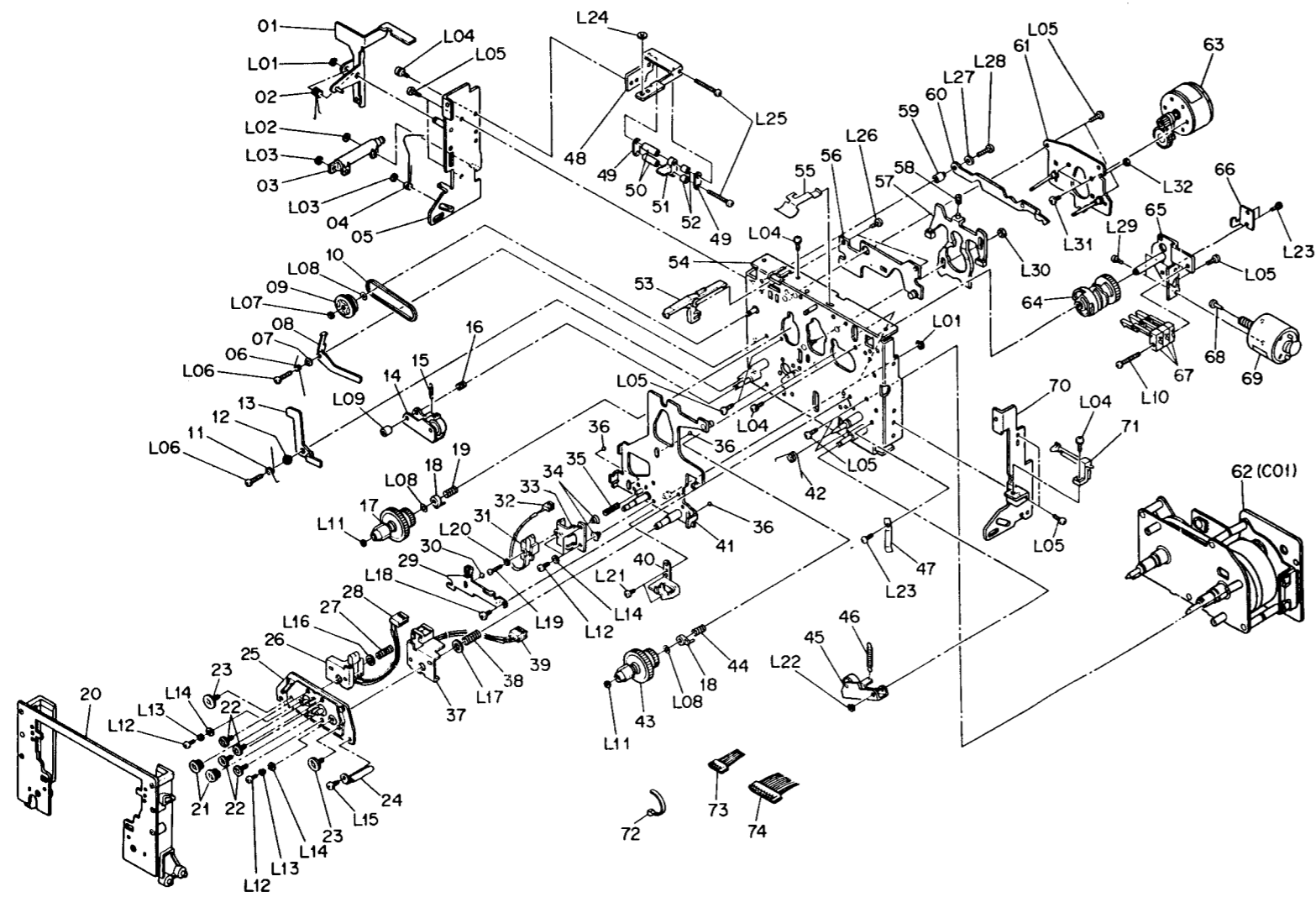

Fig. 7.4

7.5. Front Escutcheon Ass'y (B02)

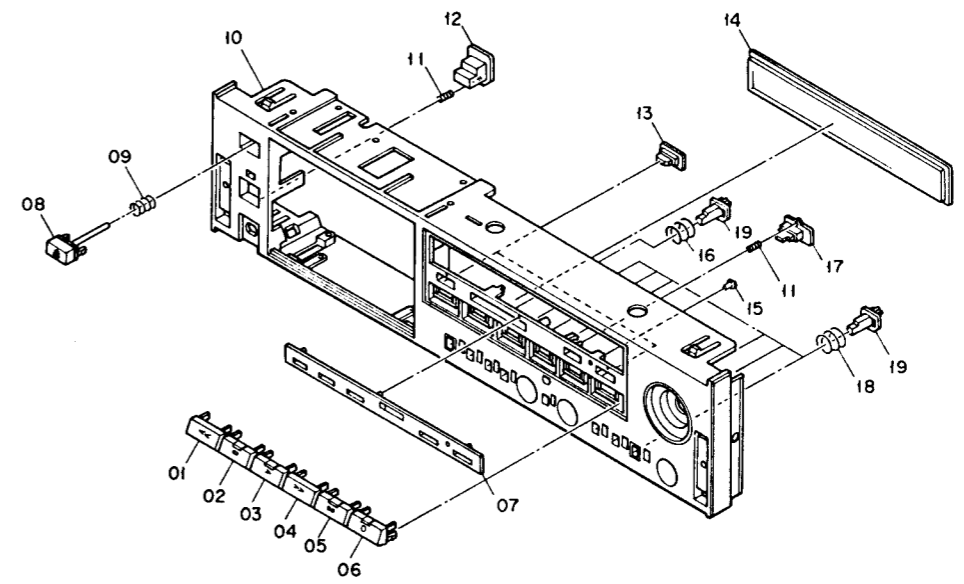

Fig. 7.5

7.6. D.D. Motor Ass'y (C01)

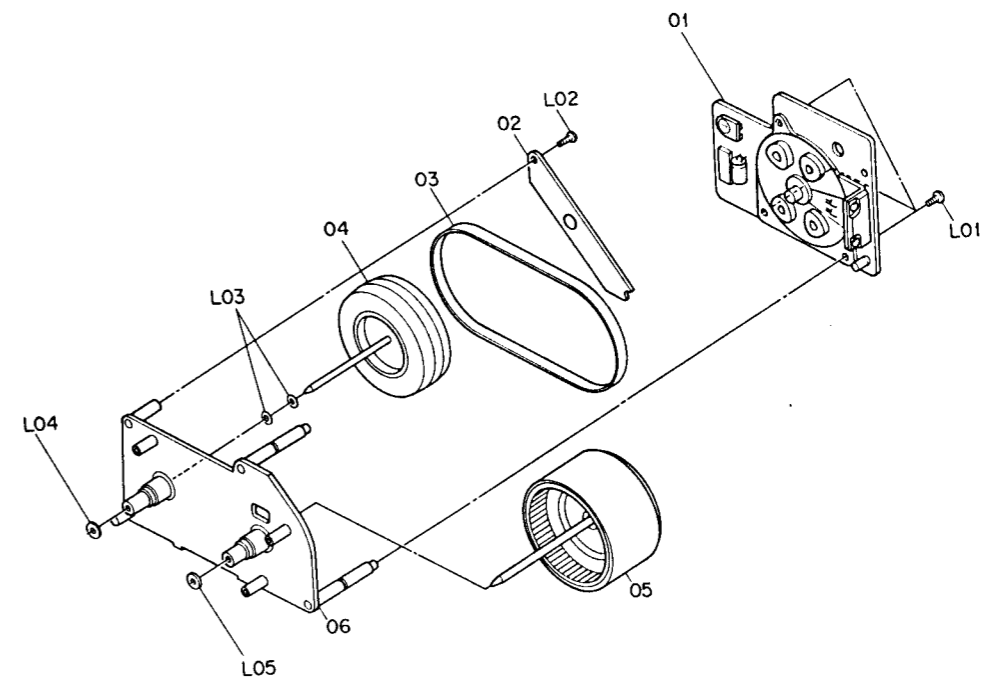

Fig. 7.6

Schematic Ref. No.	Part No.	Description	Q'ty	Schematic Ref. No.	Part No.	Description	Q'ty
7.4. Mechanism Ass'y (B01)				L05	OE03229A	FT2.5x6 @ Pan	10
				L06	OE03043A	FT2.5x10 @ Pan	2
B01	CA08889A	Mechanism Ass'y Serial No.: A13101001 -	1	L07	OE03225A	Washer 1.8x3.8x0.5	1
01	OC80021A	Eject Lever	1	L08	OE03226A	Washer 2.1x4.5x0.1	3
02	OC80020A	Eject Lever Spring	1	L09	OC81421A	Supply Tape Guide	1
03	CA80006A	Pneumatic Damper Ass'y	1	L10	OE03044A	Adjustment Nut	1
04	OC80019B	Eject Spring	1	L11	OE03049A	FT2.5x20 @ Pan	2
05	OC80018B	Cassette Case Holder L	1	L12	OE00976A	Washer 1.8x3.2x0.5	5
06	OC80617A	Back Tension Arm Spring	1	L13	OE00025A	M2x5 @ Binding	2
07	OC80618A	Back Tension Arm Collar	1	L14	OE00117A	Spring Washer 2mm	5
08	OC80619A	Back Tension Arm	1	L15	OE00866A	Washer 2x4.3x0.4	1
09	OC80620A	Back Tension Pulley	1	L16	OE00866A	M2.6x4 @ Binding	1
10	OC80621A	Back Tension Belt	1	L17	OC08774A	Plate Washer L	1
11	OC80013A	Lock Lever Spring	1	L18	OC08773A	Plate Washer R	1
12	OC80014A	Lock Lever Collar	1	L19	OE03228A	FT3x4 @ Pan	1
13	OC80015B	Lock Lever	1	L20	OE03232A	M1.7x7 @ Pan	1
14	CA80366A	Supply Pressure Roller Arm Ass'y	1	L21	OE03222A	Washer 1.8x3.8x0.3	1
15	OC81420A	Supply Pressure Roller Arm Spring	1	L22	OE03234A	M2x3 @ Pan	2
16	OC81422A	Supply Pressure Roller Arm Thrust Spring	1	L23	OE00222A	E-Ring 2mm	1
17	CA80726A	Supply Reel Hub Ass'y	1	L24	OE03035A	M2x3.2 @ Truss	3
18	OC80612A	Spring Holder	2	L25	OE03227A	Washer 2.7x5x0.5	2
19	OC80614A	Supply Reel Hub Spring	1	L26	OE03231A	M2x30 @ Pan	2
20	CA80200A	Cassette Case Ass'y	1	L27	OE03041A	FT2.5x4 @ Pan	2
21	OC08762A	Head Height Adjustment Gear	2	L28	OE03233A	Washer 2.6x8x1	1
22	OC08761A	Head Height Adjustment Screw	4	L29	OE03230A	FT2.6x12 @ Pan	1
23	OC08763A	Azimuth Alignment Screw	2	L30	OE00691A	M2x3 @ Pan (Nickel)	2
24	OC80605A	Wire Clamper	1	L31	OE03237A	Nut Hex. M2.6	1
25	CA08637A	Head Mount Base Sub Ass'y	1	L32	OE03045A	M2.6x3 @ Binding	2
26	CA08659B	R-3L Record Head Ass'y	1		OE00694A	Nut Hex. M2	1
27	OC08776A	Head Plate Spring (L)	1	7.5. Front Escutcheon Ass'y (B02)			
28	CA80731A	4P Connector	1	B02	HA05342A	Front Escutcheon Ass'y Serial No.: A13101001 -	1
29	OC80003A	Head Base Hold Plate	1	01	OH05126A	Rewind Button	1
30	OC80004A	Steel Ball 3mm	1	02	HA05359A	Stop Button Ass'y	1
31	GA02201A	E-4F Erase Head	1	03	HA05343A	Play Button Ass'y	1
32	CA80733A	2P Connector	1	04	OH05129A	FF Button	1
33	OC08768A	Erase Head Hold Plate	1	05	HA05361A	Pause Button Ass'y	1
34	OC08889A	Erase Head Hold Plate Tapering Spring	2	06	HA05360A	Rec. Button Ass'y	1
35	OC08886A	Erase Head Hold Plate Spring	1	07	OH05098A	Function Plate	1
36	OC80007A	Steel Ball 2mm	3	08	HA05344A	Eject Button Ass'y	1
37	CA08658B	P2H-L Playback Head Ass'y	1	09	OJ05404A	Eject Knob Spring	1
38	OC08775A	Head Plate Spring (R)	1	10	OH05122B	Front Escutcheon	1
39	CA80732A	4P Connector	1	11	OJ05405A	Power Switch Knob Spring	2
40	OC08771A	Tape Guide Plate	1	12	OH05125B	Power Switch Knob	2
41	CA80365A	Head Base Sub Ass'y	1	13	OH05094A	Function Button	1
42	OC80611A	Head Base Spring	1	14	OH05101A	Display Lens	1
43	CA80725A	Take-up Reel Hub Ass'y	1	15	OH05103A	LED Lens B	1
44	OC80613A	Take-up Reel Hub Spring	1	16	OJ05452B	EX Switch Spring	1
45	CA80368A	Take-up Pressure Roller Arm Ass'y	1	17	OH05096A	Button (Monitor)	1
46	OC81423A	Supply Pressure Roller Arm Spring	1	18	OJ05406A	Push Switch Button Spring	7
47	OC80610A	Cassette Case Spring	1	19	OH05097A	Push Button	8
48	OC80622A	Switch Hold Plate	1	-	OJ05458A	LED Lens Adhesive Tape	1
49	OC80623A	Switch Plate	2	-	OJ05459A	F. Plate Adhesive Tape	1
50	OC80624A	Switch Collar A	2	7.6. D.D. Motor Ass'y (C01)			
51	OC80626A	Leaf Switch	1	C01	CA80364A	D.D. Motor Ass'y Serial No.: A13101001 -	1
52	OC80625A	Switch Collar B	2	01	CA80444A	Flywheel Holder Ass'y	1
53	OC80017B	Record Protect Lever	1	02	OC81464A	Supply Flywheel Holder	1
54	CA80367A	Mechanism Chassis	1	03	OC80634A	Capstan Belt	1
55	OC80022B	Cassette Hold Spring	1	04	OC81429A	Supply Flywheel Ass'y	1
56	CA80011A	Shut-off P.C.B. Ass'y	1	05	OC81427A	Take-up Flywheel Ass'y	1
57	CA80204A	Brake Ass'y	1	06	OC81426A	Motor Plate	1
58	OC80628A	Brake Spring B	1	L01	OE03349A	FT3x5 @ Pan	3
59	OC80630A	Brake Arm Collar	1	L02	OE03229A	FT2.5x6 @ Pan	1
60	OC80629A	Brake Arm	1	L03	OE00912A	Washer 2.6x4.7x0.25 (Polyslider)	2
61	OC80030A	Reel Motor Holder	1	L04	OE03348A	Capstan Washer S	1
62	CA80364A	D.D. Motor Ass'y	1	L05	OE03051A	Washer 2.5x7x0.8	1
63	CA80730A	Reel Motor Ass'y	1				
64	OC81417A	Cam Gear	1				
65	OC81418A	Control Motor Holder	1				
66	OC81416A	Thrust Spring B	1				
67	OC80027A	Mode Switch	1				
68	OC81415A	Warm Thrust Bush	1				
69	CA80007A	Control Motor Ass'y	1				
70	OC80010D	Cassette Case Holder R	1				
71	OC80012A	Eject Sensor	1				
72	OC80037A	Insu-Lock	3				
73	OC82935A	5P Connector	1				
74	OC82936A	9P Connector	1				
L01	OE00181A	E-Ring 3mm	3				
L02	OE03235A	Plastic Washer 2x5x0.25	1				
L03	OE03052A	CS Stopper Ring 2.4mm	2				
L04	OE03236A	M2x5 @ Pan (2A)	4				

8. MOUNTING DIAGRAMS AND PARTS LIST

- Notes: 1. Mounting diagram shows a dip side view of the printed circuit board.
 2. Diode is 1SS53, 1S1555, or 1SS176 unless otherwise specified.
 3. Following transistors are interchangeable with each other.
 a. 2SA733, 2SA608SP, 2SA1048, 2SA1175
 b. 2SC945, 2SC536SP, 2SC2458, 2SC2785
 4. Abbreviation for part name:
 TR — Transistor, SiD — Silicon Diode, ZD — Zener Diode
 RK — Carbon Resistor, RM — Metal Film Resistor, RF — Fail Safe Type Resistor
 CE — Electrolytic Capacitor, CML — Mylar Capacitor, CC — Ceramic Capacitor, CPP — PP Capacitor,
 CMM — Metalized Mylar Capacitor, CSP — Polystyrene Capacitor, C — Mica Capacitor

8.1. Fuse P.C.B. Ass'y

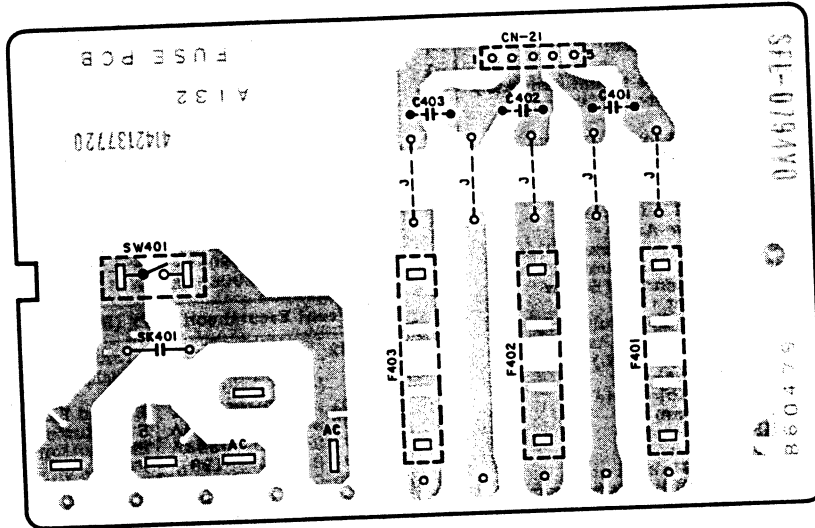

Fig. 8.1

8.2. Pin Jack P.C.B. Ass'y

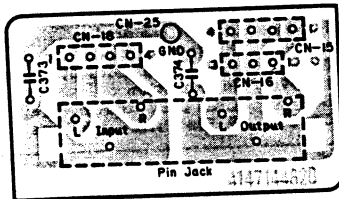

Fig. 8.2

8.3. Input Volume P.C.B. Ass'y

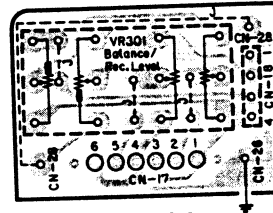

Fig. 8.3

Schematic Ref. No.	Part No.	Description	Schematic Ref. No.	Part No.	Description	Schematic Ref. No.	Part No.	Description
8.1. Fuse P.C.B. Ass'y			CN21	OB83122A	5P Connector	8.2. Pin Jack P.C.B. Ass'y		
			SW401	OB71008A	Power Switch (CR-4, CR-4A & CR-4E)		BA07055A	Pin Jack P.C.B. Ass'y
	BA07045A	Fuse P.C.B. Ass'y (CR-4 & CR-4E)		OB71006A	Power Switch (CR-40)	C373.374	OB60521A	Pin Jack P.C.B. CC 1000P 25V M
	BA07044A	Fuse P.C.B. Ass'y (CR-4A)		OB81776A	Contact Pin (CR-4 & CR-4E) (5)	CN16	OB41007A	3P Connector
	BA07046A	Fuse P.C.B. Ass'y (CR-40)		OB81848A	Fuse Holder (6)	CN18	OB83121A	4P Connector
	OB60479A	Fuse P.C.B. CC 0.1μ 50V Z		OM04131B	Fuse Label T1A 250V (CR-4 & CR-4E) (1)		OB83120A	4P Pin/Jack GOLD (1)
C401,402	OB09292A	CC 0.1μ 50V Z					OB81756A	Ground Ass'y (1)
C403	OB09292A	CC 0.1μ 50V Z		OM04191A	Fuse Label T1A 250V (CR-4 & CR-4E) (1)	8.3. Input Volume P.C.B. Ass'y		
F401	OB90285A	Fuse 1.6A (CR-4A)					BA07054A	Input Volume P.C.B. Ass'y
F401	OB90289A	Fuse T1A 250V (CR-4 & CR-4E)					OB60522A	Input Volume P.C.B. Volume 100Kx2
F401	OB90291A	Fuse 1.6A (CR-40)				VR301	OB30077A	PD Connector
F402,403	OB90285A	Fuse 1.6A (CR-4A)				CN28	OB22362B	Volume Earth Plate (1)
F402,403	OB90289A	Fuse T1A 250V (CR-4 & CR-4E)					OJ05419A	Volume Earth Plate (1)
F402,403	OB90291A	Fuse 1.6A (CR-40)					OV10050C	Wire 2mm BLK (1)
SK401	OB41929A	CC 4700P (CR-4, CR-4A & CR-4E)						
SK401	OB41826A	CC 4700P (CR-40)						

8.9. Power Supply P.C.B. Ass'y

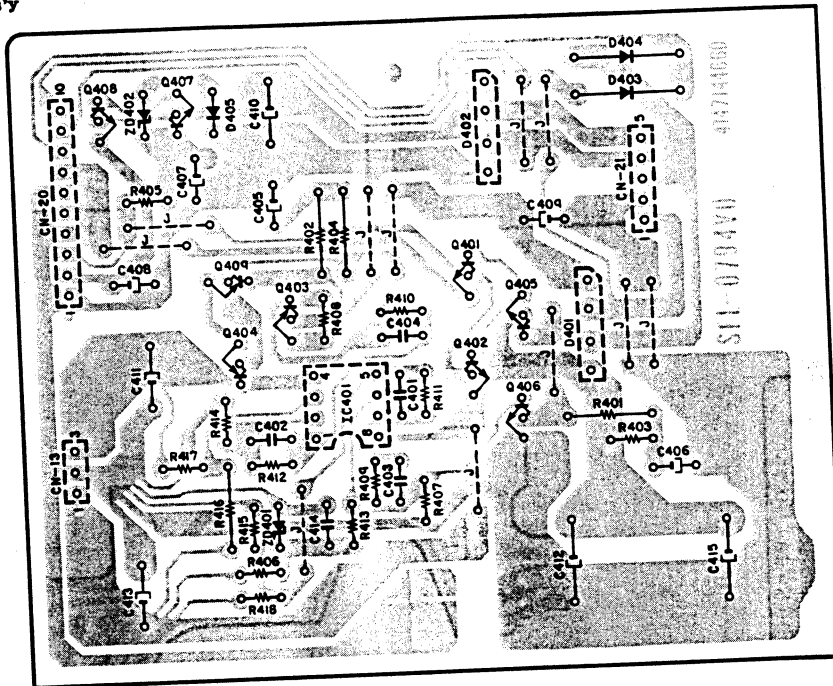

Fig. 8.9

8.10. Cal. Osc. P.C.B. Ass'y

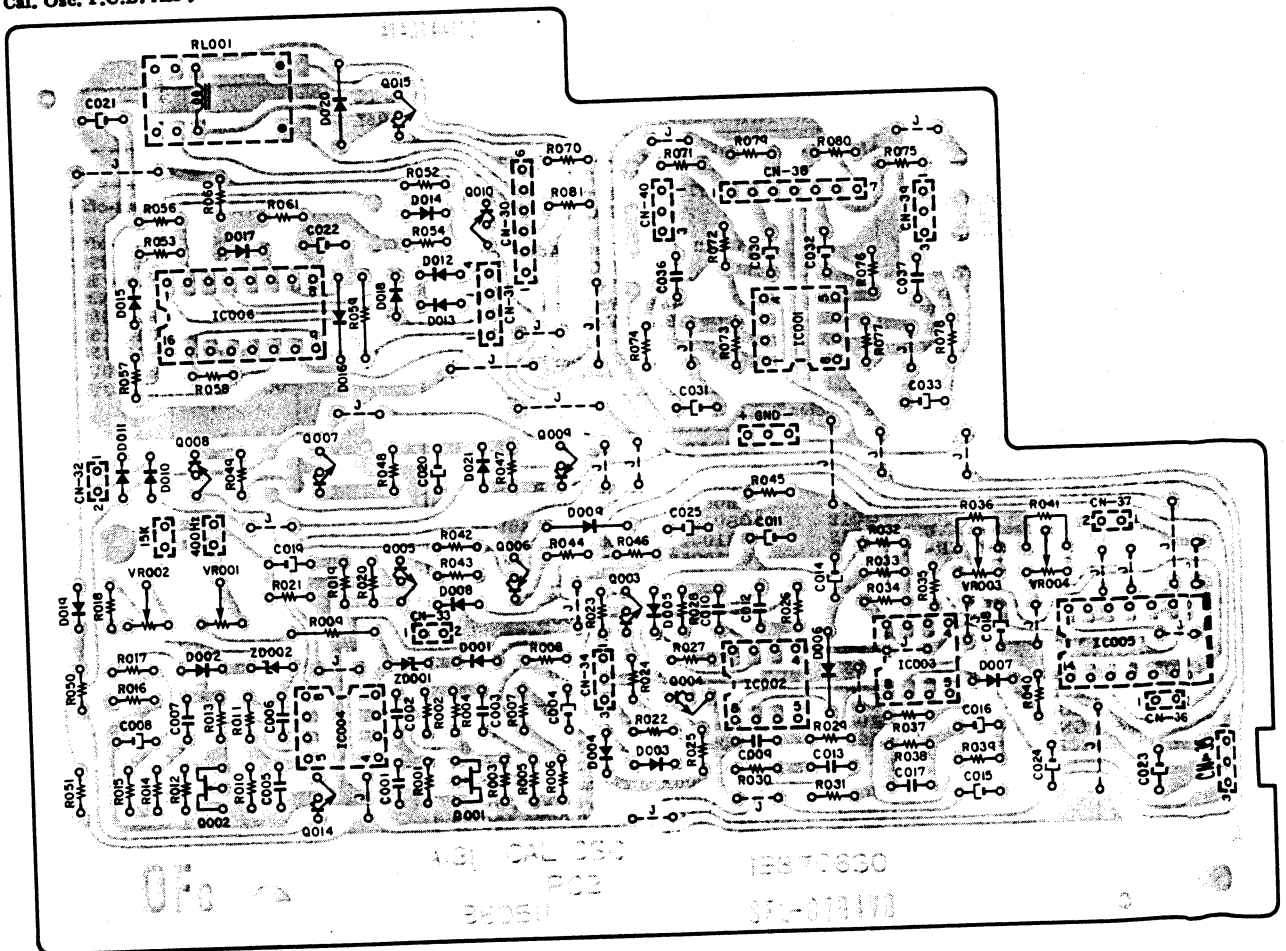

Fig. 8.10.1 Serial No.: A13102451 - (CR-4A)
A13153801 - (CR-4/4E/40)

Schematic Ref. No.	Part No.	Description	Schematic Ref. No.	Part No.	Description	Schematic Ref. No.	Part No.	Description
8.9. Power Supply P.C.B. Ass'y			8.10.1. Cal. Osc. P.C.B. Ass'y			R060,061	OB09725A	RK 100K 1/6W J
	BA07041A	Power Supply P.C.B. Ass'y		BA07192A	Cal. Osc. P.C.B. Ass'y Serial No.: A13102451 -(CR-4A) A13153801 -(CR-4/4E/40)	R070,071	OB09701A	RK 10K 1/6W J
IC401	OB60525A	Power Supply P.C.B. IC NJM4560M		OB60511A	Cal. Osc. P.C.B. IC NJM4558D	R072	OB09733A	RK 220K 1/6W J
Q401,402	OB06452A	TR 2SD1406 (Y)	IC001,002	OB06124B	IC NJM4558D	R073	OB09725A	RK 100K 1/6W J
Q403	OB06013A	TR 2SA733 (P,Q)	IC003,004	OB06144A	IC μ PD4066BC	R074	OB09723A	RK 82K 1/6W J
Q404	OB06451A	TR 2SB1015 (Y)	IC005	OB11066A	IC LC4049B	R075	OB09701A	RK 10K 1/6W J
Q405,406	OB01872A	TR 2SC945L (P,Q)	IC006	OB10022A	FET 2SK246 (GR)	R076	OB09733A	RK 220K 1/6W J
Q407	OB01872A	TR 2SC945L (P,Q)	Q001,002	OB01872A	TR 2SC945L (P,Q)	R077	OB09725A	RK 100K 1/6W J
Q408	OB06452A	TR 2SD1406 (Y)	Q003,004	OB10058A	TR DTA114ES	R078	OB09723A	RK 82K 1/6W J
Q409	OB06013A	TR 2SA733 (P,Q)	Q005	OB01872A	TR 2SC945L (P,Q)	R079,080	OB09701A	RK 10K 1/6W J
ZD401	OB12147A	ZD 5.1V	Q006	OB10058A	TR DTA114ES	R081	OB09677A	RK 1K 1/6W J
ZD402	OB12150A	ZD 5.6V	Q007	OB01872A	TR 2SC945L (P,Q)	C001	OB41306A	CMM 0.47 μ 50V J
D401,402	OB06282A	SiD DBA100B.C.	Q008	OB06013A	TR 2SA733 (P,Q)	C002	OB41288A	CML 0.015 μ 50V J
D403,404	OB12586A	SiD 1N4002	Q009,010	OB10053A	TR DTA144ES	C003	OB41098A	CML 0.022 μ 50V J
D405	OB06398A	SiD 1SS176	Q014	OB01872A	TR 2SC945L (P,Q)	C004	OB01405A	CE 1 μ 50V
R401,402	OB01679A	RK 100 1/4W J	Q015	OB10023A	ZD 7.5V UTZJ7.5B	C005	OB09856A	CML 0.01 μ 50V J
R403	OB09677A	RK 1K 1/6W J	ZD001,002	OB12442A	SiD 1SS133	C006	OB41215A	CPP 390P 100V J
R404	OB01857A	RK 1K 1/4W J	D001,002	OB12249A	SiD 1SS133	C007	OB41098A	CML 0.022 μ 50V J
R405	OB09677A	RK 1K 1/6W J	D003,004	OB12249A	SiD 1SS133	C008	OB01405A	CE 1 μ 50V
R406	OB09681A	RK 1.5K 1/6W J	D005	OB12249A	SiD 1SS133	C009	OB41221A	CPP 680P 100V J
R407,408	OB09693A	RK 4.7K 1/6W J	D006	OB12584A	SiD 1N4148	C010	OB41287A	CML 0.012 μ 50V J
R409,410	OB09701A	RK 10K 1/6W J	D007,008	OB12249A	SiD 1SS133	C011	OB41862A	CE 22 μ 16V
R411,412	OB09749A	RK 1M 1/6W J	D009	OB12584A	SiD 1N4148	C012	OB41221A	CPP 680P 100V J
R413,414	OB22310A	RM 5.11K 1/6W F	D010,011	OB12249A	SiD 1SS133	C013	OB41287A	CML 0.012 μ 50V J
R415	OB22343A	RM 10.0K 1/6W F	D012,013	OB12249A	SiD 1SS133	C014	OB01862A	CE 22 μ 16V
R416	OB09504A	RM 11K 1/4W F	D014,015	OB12249A	SiD 1SS133	C015,016	OB01405A	CE 1 μ 50V
R417	OB22347A	RM 11.0K 1/6W F	D016	OB12584A	SiD 1N4148	C017	OB41221A	CPP 680P 100V J
R418	OB22357A	RM 13.7K 1/6W F	D017,018	OB12249A	SiD 1SS133	C018,019	OB01412A	CE 10 μ 16V
C401,402	OB09393A	CC 68P 50V J	D019	OB12249A	SiD 1SS133	C020	OB40076A	CE 33 μ 16V
C403,404	OB05652A	CML 4700P 50V J	D020	OB12584A	SiD 1N4148	C021	OB01412A	CE 10 μ 16V
C405,406	OB01272A	CE 100 μ 25V	D021	OB12249A	SiD 1SS133	C022	OB01405A	CE 1 μ 50V
C407	OB01400A	CE 100 μ 16V	VR001,002	OB32130A	Semi VR 100KB	C023,024	OB01397A	CE 1000 μ 16V
C408	OB05899A	CE 220 μ 10V	VR003,004	OB32127A	Semi VR 10KB	C025	OB01412A	CE 10 μ 16V
C409	OB01401A	CE 470 μ 25V	R001	OB09676A	RK 910 1/6W J	C030,031	OB09814A	CE 1 μ 50V (LN)
C410	OB40362A	CE 6800 μ 16V	R002	OB09711A	RK 27K 1/6W J	C032,033	OB09814A	CE 1 μ 50V (LN)
C411	OB40361A	CE 2200 μ 16V	R003	OB09733A	RK 220K 1/6W J	C036,037	OB40473A	CE 10 μ 16V (BF)
C412	OB40476A	CE 8200 μ 25V M	R004	OB09719A	RK 56K 1/6W J	RL001	OB90301A	Relay 12V MR5 2-12S
C413	OB09377A	CE 4700 μ 16V	R005	OB09749A	RK 1M 1/6W J	CN30	OB81638A	6P-T Post
C414	OB41386A	CPP 100P 50V J	R006	OB09699A	RK 8.2K 1/6W J	CN31	OB81636A	4P-T Post
C415	OB40476A	CE 8200 μ 25V M	R007	OB09741A	RK 470K 1/6W J	CN32	OB83137A	2P-T Post
CN21	OB81762A	5P-T Post	R008	OB09701A	RK 10K 1/6W J	CN33	OB83138A	2P Connector
MJ	OB80151B	Wire 80mm BLK	R009	OB05626A	RK 150K 1/4W J	CN34	OB83139A	3P Connector
	OB90297A	Isolation Sheet (1)	R010	OB09676A	RK 910 1/6W J	CN35	OB83140A	3P Connector
	OE00037A	Earth Lug (1)	R011	OB09709A	RK 22K 1/6W J	CN36,37	OB81634A	2P-T Post
	OE00985A	M3x6 @ Binding (Black Chromate)(2)	R012	OB09733A	RK 220K 1/6W J	CN38	OB81639A	7P-T Post
	OJ05415A	Heat Sink (1)	R013	OB09719A	RK 56K 1/6W J	CN39	OB83144A	3P Connector
			R014	OB09749A	RK 1M 1/6W J	CN40	OB83145A	3P Connector
			R015	OB09699A	RK 8.2K 1/6W J		OB81773A	Receptacle 2P Female
			R016	OB09741A	RK 470K 1/6W J		OB81774A	Receptacle 2P Male
			R017	OB09701A	RK 10K 1/6W J			
			R018	OB09729A	RK 150K 1/6W J			
			R019	OB09685A	RK 2.2K 1/6W J			
			R020	OB09709A	RK 22K 1/6W J			
			R021	OB09653A	RK 100 1/6W J			
			R022,023	OB09701A	RK 10K 1/6W J			
			R024,025	OB09709A	RK 22K 1/6W J			
			R026	OB09725A	RK 100K 1/6W J			
			R027	OB09729A	RK 150K 1/6W J			
			R028	OB09679A	RK 1.2K 1/6W J			
			R029	OB09725A	RK 100K 1/6W J			
			R030	OB09729A	RK 150K 1/6W J			
			R031	OB09679A	RK 1.2K 1/6W J			
			R032,033	OB09701A	RK 10K 1/6W J			
			R034	OB09694A	RK 5.1K 1/6W J			
			R035	OB09689A	RK 3.3K 1/6W J			
			R036	OB09701A	RK 10K 1/6W J			
			R037	OB09725A	RK 100K 1/6W J			
			R038	OB09729A	RK 150K 1/6W J			
			R039	OB09679A	RK 1.2K 1/6W J			
			R040	OB09657A	RK 150 1/6W J			
			R041	OB09701A	RK 10K 1/6W J			
			R042	OB09725A	RK 100K 1/6W J			
			R043,044	OB09701A	RK 10K 1/6W J			
			R045,046	OB09725A	RK 100K 1/6W J			
			R047,048	OB09709A	RK 22K 1/6W J			
			R049	OB09677A	RK 1K 1/6W J			
			R050	OB09701A	RK 10K 1/6W J			
			R051	OB09725A	RK 100K 1/6W J			
			R052	OB09741A	RK 470K 1/6W J			
			R053	OB09669A	RK 470 1/6W J			
			R054	OB09741A	RK 470K 1/6W J			
			R056,057	OB09725A	RK 100K 1/6W J			
			R058	OB09749A	RK 1M 1/6W J			
			R059	OB05676A	RK 390K 1/4W J			

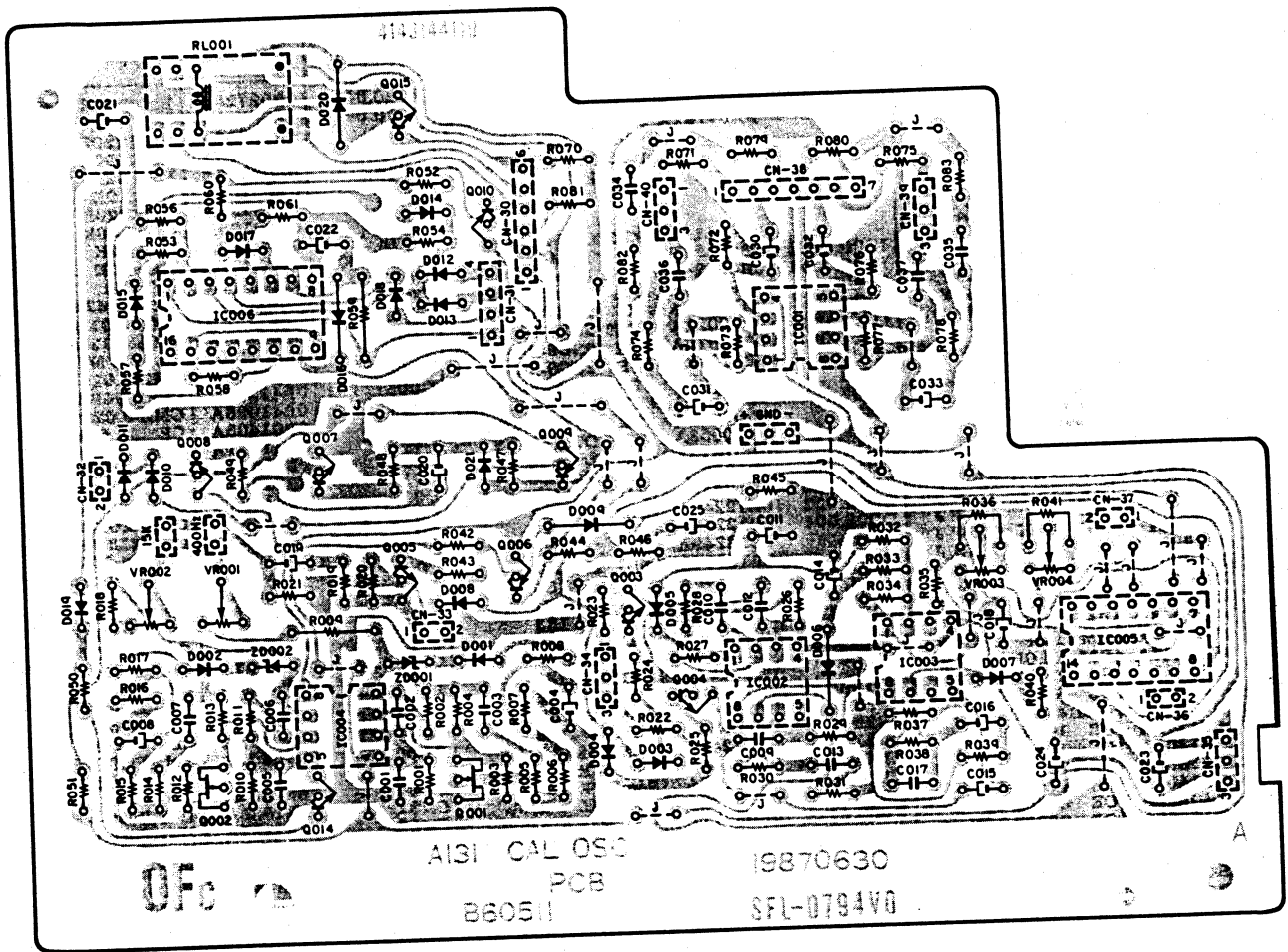

Fig. 8.10.2 Serial Nos.: A13101001 - 02450 (CR-4A)
A13150001 - 53800 (CR-4/E/40)

8.11. Flywheel Holder Ass'y

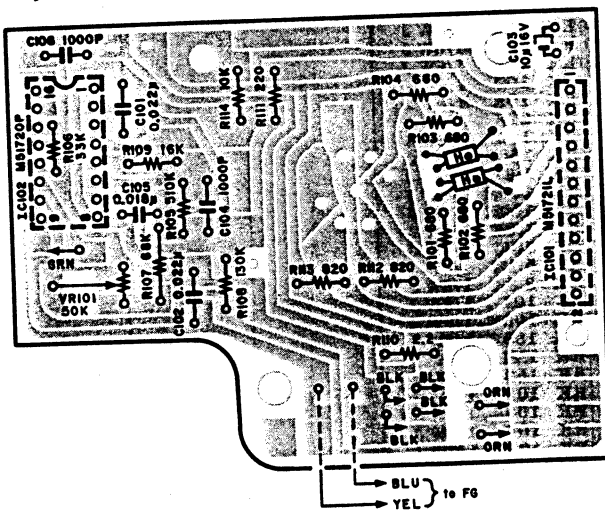

Fig. 8.11

Schematic Ref. No.	Part No.	Description
8.11. Flywheel Holder Ass'y		
	CA80444A	Flywheel Holder Ass'y
IC101	OC81951A	IC M51721L
IC102	OC81952A	IC M51720P
VR101	OB32109A	Semi VR 50K
R101,102	OB23154A	RK 680 1/4W J
103,104		
R105	OB23155A	RK 510K 1/4W J
R106	OB23156A	RK 33K 1/4W J
R107	OB22737A	RM 68K 1/8W J
R108	OB23161A	RK 130K 1/4W J
R109	OB23157A	RK 16K 1/4W J
R110	OB23158A	RK 2.2 1/4W J
R111	OB23164A	RK 220 1/4W J
R112,113	OB23159A	RK 820 1/4W J
R114	OB23160A	RK 10K 1/4W J
C101,102	OB23163A	CC 0.022μ 25V (N)
C103	OB01412A	CE 10μ 16V
C104,106	OB23162A	CC 1000P 50V K
C105	OB41748A	C Polystyrene 0.018μ 50V J
	OB11271A	Hall Sensor E5231-1

Schematic Ref. No.	Part No.	Description	Schematic Ref. No.	Part No.	Description
8.10.2. Cal. Osc. P.C.B. Ass'y					
	BA07008B	Cal. Osc. P.C.B. Ass'y Serial Nos: A13101001 - 02450 (CR-4A) A13150001 - 53800 (CR-4/E/40)	R060,061 R070,071 R072 R073 R074 R075 R076 R077 R078 R079,080 R081 R082,083 C001 C002 C003 C004 C005 C006 C007 C008 C009 C010 C011 C012 C013 C014 C015,016 C017 C018,019 C020 C021 C022 C023,024 C025 C030,031 C032,033 C034,035 C036,037 RL001	OB09725A OB09701A OB09733A OB09725A OB09723A OB09701A OB09733A OB09725A OB09723A OB09701A OB09677A OB09749A OB41306A OB41288A OB41098A OB01405A OB09856A OB41215A OB41098A OB01405A OB41221A OB41287A OB01862A OB41221A OB41287A OB01862A OB01405A OB41221A OB01412A OB40076A OB01412A OB01405A OB01397A OB01412A OB09814A OB09814A OB41390A OB40473A OB90301A	RK 100K 1/6W J RK 10K 1/6W J RK 220K 1/6W J RK 100K 1/6W J RK 82K 1/6W J RK 10K 1/6W J RK 220K 1/6W J RK 100K 1/6W J RK 82K 1/6W J RK 10K 1/6W J RK 1K 1/6W J RK 1M 1/6W J CMM 0.47μ 50V J CML 0.015μ 50V J CML 0.022μ 50V J CE 1μ 50V CML 0.01μ 50V J CPP 390P 100V J CML 0.022μ 50V J CE 1μ 50V CPP 680P 100V J CML 0.012μ 50V J CE 22μ 16V CPP 680P 100V J CML 0.012μ 50V J CE 22μ 16V CE 1μ 50V CPP 680P 100V J CE 10μ 16V CE 33μ 16V CE 10μ 16V CE 1μ 50V CE 100μ 16V CE 10μ 16V CE 1μ 50V (LN) CE 1μ 50V (LN) CPP 150P 50V J CE 10μ 16V (BP) Relay 12V MR52-12S
IC001,002 IC003,004 IC005 IC006 Q001,002 Q003,004 Q005 Q006 Q007 Q008 Q009,010 Q014 Q015 ZD001,002 D001,002 D003,004 D005 D006 D007,008 D009 D010,011 D012,013 D014,015 D016 D017,018 D019 D020 D021 VR001,002 VR003,004 R001 R002 R003 R004 R005 R006 R007 R008 R009 R010 R011 R012 R013 R014 R015 R016 R017 R018 R019 R020 R021 R022,023 R024,025 R026 R027 R028 R029 R030 R031 R032,033 R034 R035 R036 R037 R038 R039 R040 R041 R042 R043,044 R045,046 R047,048 R049 R050 R051 R052 R053 R054 R056,057 R058 R059	OB60511A OB06124B OB06124B OB06144A OB11066A OB10022A OB01872A OB01872A OB10058A OB01872A OB06013A OB10053A OB01872A OB10023A OB12442A OB12249A OB12249A OB12249A OB06181A OB12249A OB12249A OB12249A OB06181A OB12249A OB12249A OB12249A OB06181A OB12249A OB12249A OB06181A OB12249A OB32130A OB32127A OB09676A OB09711A OB09733A OB09719A OB09749A OB09699A OB09741A OB09701A OB05626A OB09676A OB09709A OB09733A OB09719A OB09749A OB09699A OB09741A OB09701A OB09729A OB09685A OB09709A OB09653A OB09701A OB09709A OB09725A OB09729A OB09679A OB09701A OB09694A OB09689A OB09701A OB09725A OB09729A OB09679A OB09657A OB09701A OB09725A OB09701A OB09725A OB09709A OB09677A OB09701A OB09725A OB09741A OB09669A OB09741A OB09725A OB09749A OB06676A	Cal. Osc. P.C.B. IC NJM4558D IC NJM4558D IC μPD4066BC IC LC4049B FET 2SK246 (GR) TR 2SC945L (P,Q) TR 2SC945L (P,Q) TR DTA114ES TR 2SC945L (P,Q) TR 2SA733 (P,Q) TR DTA144ES TR 2SC945L (P,Q) TR 2SC2002 (K) ZD 7.5V UTZJ7.5B SID 1SS133 SID 1SS133 SID 1SS133 SID 1SS53 SID 1SS133 SID 1SS133 SID 1SS53 SID 1SS133 SID 1SS133 SID 1SS133 SID 1SS53 Semi VR 100KB Semi VR 10KB RK 910 1/6W J RK 27K 1/6W J RK 220K 1/6W J RK 56K 1/6W J RK 1M 1/6W J RK 8.2K 1/6W J RK 470K 1/6W J RK 10K 1/6W J RK 150K 1/4W J RK 910 1/6W J RK 22K 1/6W J RK 220K 1/6W J RK 56K 1/6W J RK 1M 1/6W J RK 8.2K 1/6W J RK 470K 1/6W J RK 10K 1/6W J RK 150K 1/6W J RK 2.2K 1/6W J RK 22K 1/6W J RK 100 1/6W J RK 10K 1/6W J RK 22K 1/6W J RK 100K 1/6W J RK 150K 1/6W J RK 1.2K 1/6W J RK 10K 1/6W J RK 5.1K 1/6W J RK 3.3K 1/6W J RK 10K 1/6W J RK 100K 1/6W J RK 150K 1/6W J RK 1.2K 1/6W J RK 150 1/6W J RK 10K 1/6W J RK 100K 1/6W J RK 10K 1/6W J RK 100K 1/6W J RK 22K 1/6W J RK 1K 1/6W J RK 10K 1/6W J RK 100K 1/6W J RK 470K 1/6W J RK 470 1/6W J RK 470K 1/6W J RK 100K 1/6W J RK 1M 1/6W J RK 390K 1/4W J	CN30 CN31 CN32 CN33 CN34 CN35 CN36,37 CN38 CN39 CN40	OB81638A OB81636A OB83137A OB83138A OB83139A OB83140A OB81634A OB81639A OB83144A OB83145A OB81773A OB81774A	6P-T Post 4P-T Post 2P-T Post 2P Connector 3P Connector 3P Connector 2P-T Post 7P-T Post 3P Connector 3P Connector Receptacle 2P Female (2) Receptacle 2P Male (2)

8.12. Control P.C.B. Ass'y

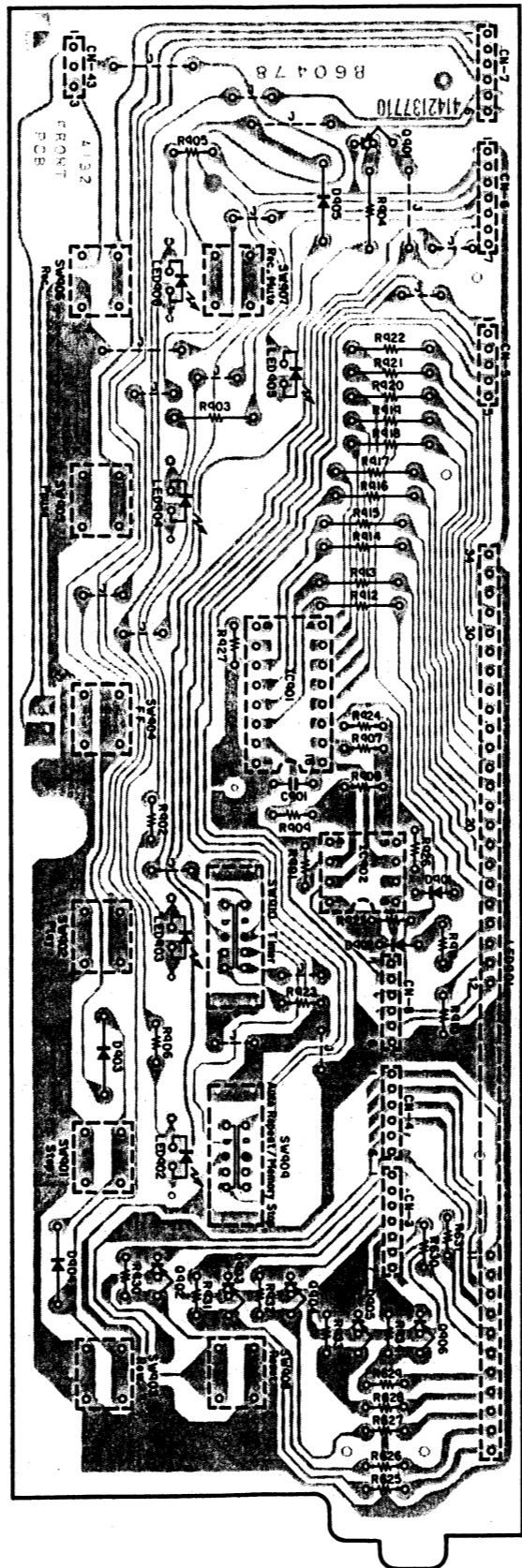

Fig. 8.12

Schematic Ref. No.	Part No.	Description
8.12. Control P.C.B. Ass'y		
	BA07042A	Control P.C.B. Ass'y
IC901 IC902 Q901 Q902,903 Q904,905 Q906 LED901 LED902,903 LED904 LED905 LED906,907 D901,902 D903,904 D905 R625,626 R627,628 R629,630 R631 R901 R902 R903 R904 R905 R906 R907,908 R909 R910 R911 R912,913 R914,915 R916,917 R918,919 R920,921 R922 R923 R924 R925,926 R927 R930,931 R932,933 R934 CN01 CN3 CN4 CN5 CN6 CN7 CN8 CN43 SW901,902 SW903,904 SW905,906 SW907,908 SW909,910	OB60478A OB06369A OB11372A OB10003A OB10029A OB10029A OB10029A OB12587A OB12578A OB12578A OB12577A OB12579A OB06398A OB12584A OB12584A OB09641A OB09641A OB09641A OB09641A OB09661A OB09657A OB05795A OB05645A OB08659A OB09661A OB09677A OB09677A OB09659A OB09655A OB01679A OB01679A OB01679A OB01679A OB01679A OB01679A OB01679A OB01679A OB09797A OB09687A OB09694A OB09701A OB09701A OB09701A OB09701A OB09701A OB09281A OB83123A OB83128A OB83124A OB83127A OB83126A OB83263A OB83148A OB70043A OB70043A OB70043A OB07437A OJ05416A	Control P.C.B. IC TA7612P IC NJM2403D TR 2SA1345 TR 2SA933S TR 2SA933S TR 2SA933S Display Unit SL-7663-40 LED SLR-34DC4F Green LED SLR-34DC4F Green LED SLR-34DC4F LED SLR-320DC4F SID 1SS176 SID 1N4148 SID 1N4148 RK 33 1/6W J RK 33 1/6W J RK 33 1/6W J RK 33 1/6W J RK 220 1/6W J RK 150 1/6W J RK 150 1/4W J RK 270 1/4W J RK 180 1/6W J RK 220 1/6W J RK 1K 1/6W J RK 1K 1/6W J RK 180 1/6W J RK 120 1/6W J RK 100 1/4W J RK 100 1/4W J RK 100 1/4W J RK 100 1/4W J RK 100 1/4W J RK 100 1/4W J RK 120 1/4W J RK 2.7K 1/6W J RK 5.1K 1/6W J RK 10K 1/6W J RK 10K 1/6W J RK 10K 1/6W J RK 10K 1/6W J CC 150P 50V K 7P Connector 6P Connector 5P Connector 7P Connector 6P Connector 6P Connector 3P Connector Tact Switch SKHHPM Tact Switch SKHHPM Tact Switch SKHHPM Slide Switch ESD 14150 LED Reflector (4)

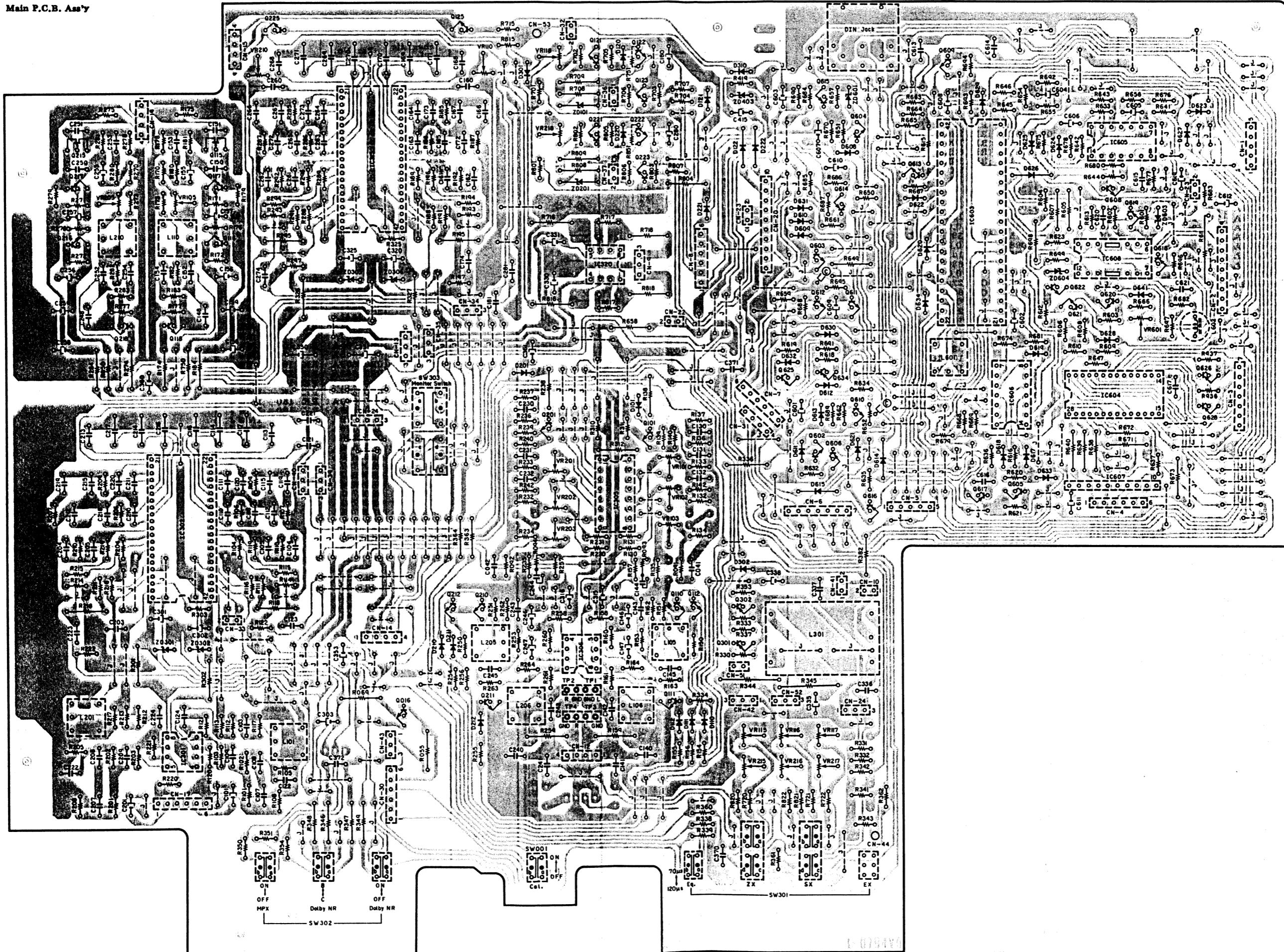

Fig. 8.13.1 Serial No.: A13102451 - (CR-4A)
A13153801 - (CR-4/4E/40)

Schematic Ref. No.	Part No.	Description	Schematic Ref. No.	Part No.	Description	Schematic Ref. No.	Part No.	Description	Schematic Ref. No.	Part No.	Description	Schematic Ref. No.	Part No.	Description	Schematic Ref. No.	Part No.	Description
R194	OB22294A	RM 3.83K 1/6W F	R218	OB09523A	RM 13.7K 1/4W F				R804	OB05508A	RK 56K 1/4W J	C353	OB01409A	CE 47μ 25V	R640	OB05575A	RK 560 1/4W J
R195	OB09547A	RM 2.21K 1/4W F	R219	OB22380A	RM 22.1K 1/6W F	IC306	OB06387A	IC NJM2043DD	R805,806	OB09725A	RK 100K 1/6W J	C372	OB01780A	CML 0.1μ 50V J	R641	OB09687A	RK 2.7K 1/6W J
R196	OB22380A	RM 22.1K 1/6W F	R220,221	OB09677A	RK 1K 1/6W J	Q110,111	OB06299A	TR 2SC2878	R807	OB09725A	RK 100K 1/6W J	SW001	OB70121A	Push Switch SPUJ19	R642,643	OB09701A	RK 10K 1/6W J
R197	OB09717A	RK 47K 1/6W J	R222	OB09733A	RK 220K 1/6W J	Q112	OB10033A	TR 2SC1740S	R808	OB05692A	RK 68K 1/4W J	SW301	OB70114A	Push Switch SPUJ42	R644,645	OB09701A	RK 10K 1/6W J
R285	OB09673A	RK 680 1/6W J	R301,302	OB24156A	RF 62 1/4W J	Q210,211	OB06299A	TR 2SC2878	R809	OB05776A	RK 1M 1/4W J	SW302	OB70113A	Push Switch SPUJ32	R646,647	OB09701A	RK 10K 1/6W J
R286	OB09698A	RK 7.5K 1/6W J	R303	OB22469A	RM 130K 1/6W F	Q212	OB10033A	TR 2SC1740S	C180	OB09148A	CE 10μ 25V (LN)	SW303	OB70122A	Push Switch SPUL12	R649	OB01888A	RK 10K 1/4W J
R287	OB09700A	RK 9.1K 1/6W J	C101	OB09148A	CE 10μ 25V (LN)	D110,111	OB06398A	SID 1SS176	C181	OB01780A	CML 0.1μ 50V J	CN30	OB83135A	6P Connector	R650,651	OB09701A	RK 10K 1/6W J
R288	OB09725A	RK 100K 1/6W J	C103	OB09404A	CPP 1000P 100V J	D112	OB06398A	SID 1SS176	C280	OB09148A	CE 10μ 25V (LN)	CN43	OB81635A	3P-T Post	R652	OB09701A	RK 10K 1/6W J
R289	OB09749A	RK 1M 1/6W J	C104,105	OB41133A	CC 33P 50V J	D210,211	OB06398A	SID 1SS176	C281	OB01780A	CML 0.1μ 50V J	CN44	OB81117A	1P Contact Pin	R654,655	OB09725A	RK 100K 1/6W J
R291	OB22229A	RM 1.00K 1/6W F	C107,108	OB09792A	CC 68P 50V J	D212	OB06398A	SID 1SS176	CN8	OB83137A	2P Connector		OB05418B	P.C.B. Holder (1)	R658	OB09725A	RK 100K 1/6W J
R292	OB22201A	RM 562 1/6W F	C109	OB09393A	CC 33P 50V J	L105	OB51260A	L-C Block 42-5025	CN32	OB83141A	2P Connector		OB05575A	Rivet 3x3.5 (2)	R659	OB09725A	RK 470 1/4W J
R293	OB22285A	RM 3.24K 1/6W F	C110	OB41139A	CPP 3900P 100V G	L106	OB51258A	Trap Coil 1.05mH	CN36	OB83142A	2P Connector				R661,662	OB09713A	RK 33K 1/6W J
R294	OB22294A	RM 3.83K 1/6W F	C111	OB41143A	CPP 5600P 100V G	L205	OB51260A	L-C Block 42-5025	CN37						R663,664	OB09717A	RK 47K 1/6W J
R295	OB09547A	RM 2.21K 1/4W F	C112	OB05557A	CML 0.015μ 50V J	L206	OB51258A	Trap Coil 1.05mH							R665	OB09717A	RK 47K 1/6W J
R296	OB22380A	RM 22.1K 1/6W F	C113	OB05682A	CML 0.068μ 50V J	R093,094	OB09723A	RK 82K 1/6W J							R666	OB09664A	RK 300 1/6W J
R297	OB09717A	RK 47K 1/6W J	C114	OB41300A	CMM 0.15μ 50V J	R150	OB09681A	RK 1.5K 1/6W J							R667,668	OB09717A	RK 47K 1/6W J
R325	OB22469A	RM 130K 1/6W F	C115	OB05813A	CML 0.056μ 50V J	R151	OB09675A	RK 820 1/6W J	IC320	OB06370A	IC NJM4556D	IC604	OB06368A	IC LM6416E-106	R669,670	OB09717A	RK 47K 1/6W J
R326,327	OB24156A	RF 62 1/4W J	C116	OB41302A	CMM 0.22μ 50V J	R153	OB09703A	RK 12K 1/6W J	Q125	OB06299A	TR 2SC2878	IC606	OB06214A	IC μPD4071BC	R671,672	OB05625A	RK 220K 1/4W J
C160	OB41386A	CPP 100P 50V J	C117	OB09876A	CMM 0.47μ 50V J	R156	OB09701A	RK 10K 1/6W J	Q225	OB06299A	TR 2SC2878	IC607	OB11369A	IC TA64	R673	OB05625A	RK 220K 1/4W J
C161,162	OB41133A	CPP 2200P 100V G	C118,119	OB09187A	CE 1μ 50V (BP)	R157	OB09709A	RK 22K 1/6W J	D310	OB06398A	SID 1SS176	IC608	OB11368A	IC LB1649	R674	OB09737A	RK 220K 1/6W J
C163	OB41139A	CPP 3900P 100V G	C120	OB05681A	CML 0.01μ 50V J	R158	OB09713A	RK 33K 1/6W J	R715	OB09693A	RK 4.7K 1/6W J	Q602,603	OB10007A	TR 2SC3399	R675,676	OB09737A	RK 330K 1/6W J
C164	OB41143A	CPP 5600P 100V G	C121	OB40473A	CE 10μ 16V (BP)	R159	OB09733A	RK 220K 1/6W J	R716	OB01889A	RK 100K 1/4W J	Q604	OB10007A	TR 2SC3399	R677,678	OB09737A	RK 330K 1/6W J
C165,166	OB09187A	CE 1μ 50V (BP)	C122	OB41388A	CPP 120P 50V J	R160	OB05936A	RK 10 1/4W J	R717	OB09725A	RK 100K 1/6W J	Q605	OB06299A	TR 2SC2878	R679	OB09701A	RK 10K 1/6W J
C167	OB05813A	CML 0.056μ 50V J	C123,124	OB40473A	CE 10μ 16V (BP)	R161	OB22229A	RM 1.00K 1/6W F	R718	OB24155A	RF 12 1/4W J	Q606	OB10033A	TR 2SA1345	R680	OB09749A	RK 1M 1/6W J
C168	OB05682A	CML 0.068μ 50V J	C201	OB09148A	CE 10μ 25V (LN)	R162	OB22248A	RM 1.54K 1/6W F	R815	OB09693A	RK 4.7K 1/6W J	Q608,609	OB10033A	TR 2SC1740S	R681	OB09735A	RK 270K 1/6W J
C169	OB41300A	CMM 0.15μ 50V J	C203	OB09404A	CPP 1000P 100V J	R163	OB22296A	RM 3.92K 1/6W F	R816	OB01889A	RK 100K 1/4W J	Q610,611	OB10033A	TR 2SC1740S	R682	OB09611A	RK 1.8K 1/6W J
C170	OB41302A	CMM 0.22μ 50V J	C204,205	OB41133A	CPP 2200P 100V G	R164	OB22431A	RM 59.0K 1/6W F	R817	OB09725A	RK 100K 1/6W J	Q612,613	OB10029A	TR 2SA933S	R683	OB09623A	RF 5.6 1/6W J
C171	OB09876A	CMM 0.47μ 50V J	C207,208	OB09792A	CC 33P 50V J	R165	OB09733A	RK 220K 1/6W J	R818	OB24155A	RF 12 1/4W J	Q614,615	OB10029A	TR 2SA933S	R684	OB09669A	RK 470 1/6W J
C172	OB05557A	CML 0.015μ 50V J	C209	OB09393A	CC 68P 50V J	R250	OB09681A	RK 1.5K 1/6W J	C330,331	OB01403A	CE 47μ 16V	Q616,617	OB10029A	TR 2SA933S	R685	OB09689A	RK 3.3K 1/6W J
C173	OB05681A	CML 0.01μ 50V J	C210	OB41139A	CPP 3900P 100V G	R251	OB09675A	RK 820 1/6W J				Q618,619	OB06013A	TR 2SA733 (P,Q)	R686	OB09697A	RK 6.8K 1/6W J
C174	OB40473A	CE 10μ 16V (BP)	C211	OB41143A	CPP 5600P 100V G	R253	OB09703A	RK 12K 1/6W J				Q620,621	OB01872A	TR 2SC945L (P,Q)	R687	OB09689A	RK 3.3K 1/6W J
C260	OB41386A	CPP 100P 50V J	C212	OB05557A	CML 0.015μ 50V J	R254,255	OB09701A	RK 10K 1/6W J	Q301	OB06202A	TR 2SA562TM (Y)	Q622	OB01872A	TR 2SC945L (P,Q)	R688	OB09707A	RK 18K 1/6W J
C261,262	OB41133A	CPP 2200P 100V G	C213	OB05682A	CML 0.068μ 50V J	R256	OB09709A	RK 22K 1/6W J	Q302	OB10029A	TR 2SA933S	Q625	OB10033A	TR 2SC1740S	R689	OB09719A	RK 56K 1/6W J
C263	OB41139A	CPP 3900P 100V G	C214	OB41300A	CMM 0.15μ 50V J	R257	OB09713A	RK 33K 1/6W J	D302	OB06398A	SID 1SS176	Q626	OB10029A	TR 2SA933S	R690	OB09721A	RK 68K 1/6W J
C264	OB41143A	CPP 5600P 100V G	C215	OB05813A	CML 0.056μ 50V J	R258	OB09733A	RK 220K 1/6W J	L301	OB51256A	Bias Osc. B01-JF	Q628	OB10029A	TR 2SA933S	R691	OB09681A	RK 1.5K 1/6W J
C265,266	OB09187A	CE 1μ 50V (BP)	C216	OB41302A	CMM 0.22μ 50V J	R259	OB05936A	RK 10 1/4W J	VR115	OB32127A	Semi VR 10K	Q634	OB10097A	TR 2SA952 (K,L)	R692,693	OB09713A	RK 33K 1/6W J
C267	OB05813A	CML 0.056μ 50V J	C217	OB09876A	CMM 0.47μ 50V J	R260	OB22229A	RM 1.00K 1/6W F	VR116	OB32128A	Semi VR 20K	ZD403	OB12179A	ZD 15V	R694	OB09713A	RK 33K 1/6W J
C268	OB05682A	CML 0.068μ 50V J	C218,219	OB09187A	CE 1μ 50V (BP)	R261	OB22248A	RM 1.54K 1/6W F	VR117	OB32129A	Semi VR 50K	ZD601	OB12167A	ZD 10V	R695	OB09695A	RK 5.6K 1/6W J
C269	OB41300A	CMM 0.15μ 50V J	C220	OB05681A	CE 10μ 16V (BP)	R262	OB22296A	RM 3.92K 1/6W F	VR118	OB32127A	Semi VR 10K	ZD602	OB12167A	ZD 10V	R696,697	OB09670A	RK 510 1/6W J
C270	OB41302A	CMM 0.22μ 50V J	C221	OB40473A	CE 10μ 16V (BP)	R263	OB22431A	RM 59.0K 1/6W F	VR215	OB32127A	Semi VR 10K	ZD603	OB12150A	ZD 5.6V	R698	OB01857A	RK 1K 1/4W J
C271	OB09876A	CMM 0.47μ 50V J	C222	OB41388A	CPP 120P 50V J	R264	OB09733A	RK 220K 1/6W J	VR216	OB32128A	Semi VR 20K	ZD603	OB12150A	ZD 5.6V	R699	OB09677A	RK 1K 1/6W J
C272	OB05557A	CML 0.015μ 50V J	C223,224	OB40473A	CE 10μ 16V (BP)	R264	OB09322A	CPP 330P 100V J	VR217	OB32129A	Semi VR 50K	ZD604	OB12153A	ZD 6.2V	R936,937	OB09701A	RK 10K 1/6W J
C273	OB05681A	CML 0.01μ 50V J	C301,302	OB01391A	CE 220μ 25V	C140	OB09270A	CPP 470P 100V J	R330	OB09669A	RK 470 1/6W J	ZD604	OB12153A	ZD 6.2V	C415	OB01403A	CE 47μ 16V
C274	OB40473A	CE 10μ 16V (BP)	C303	OB01674A	CE 10μ 25V	C141	OB09270A	CPP 470P 100V J	R331,332	OB09693A	RK 4.7K 1/6W J	D608	OB06398A	SID 1SS176	C601,602	OB09223A	CE 1μ 50V (LN)
C320	OB01391A	CE 220μ 25V	CN33	OB81634A	2P-T Post	C142	OB09834A	CPP 2200P 100V J	R333,334	OB09701A	RK 10K 1/6W J	D609,610	OB06398A	SID 1SS176	C603	OB09223A	CE 1μ 50V (LN)
C325	OB01391A	CE 220μ 25V	CN39,40	OB81635A	3P-T Post	C143	OB09993A	CML 820P 50V J	R336	OB05622A	RK 2.2K 1/4W J	D611,612	OB06398A	SID 1SS176	C604	OB09327A	CE 0.33μ 50V (LN)
CN34	OB81635A	3P-T Post				C144	OB09828A	CPP 8200P 100V J	R337	OB09721A	RK 68K 1/6W J	D613	OB06398A	SID 1SS176	C605	OB09222A	CE 0.47μ 50V (LN)
						C145	OB05685A	CML 0.082μ 50V J	R338,339	OB09725A	RK 100K 1/6W J	D614,615	OB12584A	SID 1N4148	C606	OB09332A	CE 2.2μ 50V (LN)
						C146	OB09814A	CE 1μ 50V (LN)	R341,342	OB09733A	RK 220K 1/6W J	D617	OB06398A	SID 1SS176	C607	OB09148A	CE 10μ 25V (LN)
						C147	OB40154A	CE 47μ 16V (LN)	R343	OB09733A	RK 220K 1/6W J	D618,619	OB06398A	SID 1SS176	C608,609	OB09150A	CE 33μ 25V (LN)
						C240	OB09322A	CPP 330P 100V J	R344	OB24158A	RF 10 1W J	D620,621	OB06398A	SID 1SS176	C610	OB01412A	CE 10μ 16V
						C241	OB09270A	CPP 470P 100V J	R345	OB24159A	RF 22 1W J	D622,623	OB06398A	SID 1SS176	C611	OB05841A	CE 330μ 10V
						C242	OB09834A	CPP 2200P 100V J	R353	OB09717A	RK 47K 1/6W J	D624,62					

Schematic Ref. No.	Part No.	Description	Schematic Ref. No.	Part No.	Description	Schematic Ref. No.	Part No.	Description	Schematic Ref. No.	Part No.	Description	Schematic Ref. No.	Part No.	Description	Schematic Ref. No.	Part No.	Description
R193	OB22285A	RM 3.24K 1/6W F	R218	OB09523A	RM 13.7K 1/4W F				R804	OB05508A	RK 56K 1/4W J	C353	OB01409A	CE 47μ 25V	R640	OB05575A	RK 560 1/4W J
R194	OB22294A	RM 3.83K 1/6W F	R219	OB22380A	RM 22.1K 1/6W F				R805,806	OB09725A	RK 100K 1/6W J	C372	OB01780A	CML 0.1μ 50V J	R641	OB09687A	RK 2.7K 1/6W J
R195	OB09547A	RM 2.21K 1/4W F	R220,221	OB09677A	RK 1K 1/6W J	IC306	OB06387A	IC NJM2043DD	R807	OB09725A	RK 100K 1/6W J	SW001	OB70121A	Push Switch SPUJ19	R642,643	OB09701A	RK 10K 1/6W J
R196	OB22380A	RM 22.1K 1/6W F	R222	OB09733A	RK 220K 1/6W J	Q110,111	OB06299A	TR 2SC2878	R808	OB05692A	RK 68K 1/4W J	SW301	OB70114A	Push Switch SPUJ42	R644,645	OB09701A	RK 10K 1/6W J
R197	OB09717A	RK 47K 1/6W J	R301,302	OB24156A	RF 62 1/4W J	Q210,211	OB06299A	TR 2SC2878	R809	OB05776A	RK 1M 1/4W J	SW302	OB70113A	Push Switch SPUJ32	R646,647	OB09701A	RK 10K 1/6W J
R285	OB09673A	RK 680 1/6W J	R303	OB22469A	RM 130K 1/6W F	Q212	OB10033A	TR 2SC1740S	R851	OB09749A	RK 1M 1/6W J	SW303	OB70122A	Push Switch SPUL12	R649	OB01888A	RK 10K 1/4W J
R286	OB09698A	RK 7.5K 1/6W J	C101	OB09148A	CE 10μ 25V (LN)	D110,111	OB06398A	SID 1SS176	C180	OB09148A	CE 10μ 25V (LN)	CN30	OB83135A	6P Connector	R650,651	OB09701A	RK 10K 1/6W J
R287	OB09700A	RK 9.1K 1/6W J	C103	OB09404A	CE 10μ 25V (LN)	D112	OB06398A	SID 1SS176	C181	OB01780A	CML 0.1μ 50V J	CN43	OB81635A	3P-T Post	R652	OB09701A	RK 10K 1/6W J
R288	OB09725A	RK 100K 1/6W J	C104,105	OB41133A	CE 10μ 25V (LN)	D210,211	OB06398A	SID 1SS176	C280	OB09148A	CE 10μ 25V (LN)	CN44	OB81117A	1P Connector Pin	R654,655	OB09725A	RK 100K 1/6W J
R289	OB09749A	RK 1M 1/6W J	C107,108	OB09792A	CC 33P 50V J	D212	OB06398A	SID 1SS176	C281	OB01780A	CML 0.1μ 50V J		OJ05418A	P.C.B. Holder (1)	R656,657	OB09725A	RK 100K 1/6W J
R291	OB22229A	RM 1.00K 1/6W F	C109	OB09393A	CC 68P 50V J	L105	OB06398A	SID 1SS176	CN8	OB81763A	6P-T Post		OJ05575B	Rivet 3x3.5 (2)	R658	OB05576A	RK 470 1/4W J
R292	OB22201A	RM 562 1/6W F	C110	OB41139A	CPP 3900P 100V G	L106	OB06398A	SID 1SS176	CN32	OB83137A	2P Connector				R659	OB09725A	RK 100K 1/6W J
R293	OB22285A	RM 3.24K 1/6W F	C111	OB41139A	CPP 5600P 100V G	L106	OB51260A	L-C Block 42-5025	CN36	OB83141A	2P Connector				R661,662	OB09713A	RK 33K 1/6W J
R294	OB22294A	RM 3.83K 1/6W F	C112	OB41139A	CPP 5600P 100V G	L205	OB51260A	L-C Block 42-5025	CN37	OB83142A	2P Connector				R663,664	OB09717A	RK 47K 1/6W J
R295	OB09547A	RM 2.21K 1/4W F	C113	OB05682A	CML 0.068μ 50V J	L206	OB51260A	L-C Block 42-5025				IC603	OB11020A	IC TMP4315BP-1814	R666	OB09664A	RK 300 1/6W J
R296	OB22380A	RM 22.1K 1/6W F	C114	OB41300A	CMM 0.15μ 50V J	R150	OB09681A	RK 1.5K 1/6W J							R667,668	OB09717A	RK 47K 1/6W J
R297	OB09717A	RK 47K 1/6W J	C115	OB05813A	CML 0.056μ 50V J	R151	OB09675A	RK 820 1/6W J	IC320	OB06370A	IC NJM4556D	IC604	OB06368A	IC LM6416E-106	R669,670	OB09717A	RK 47K 1/6W J
R325	OB22469A	RM 130K 1/6W F	C116	OB41302A	CMM 0.22μ 50V J	R153	OB09703A	RK 12K 1/6W J	Q125	OB06299A	TR 2SC2878	IC605	OB06317A	IC μPD4030BC	R671,672	OB05625A	RK 220K 1/4W J
R326,327	OB24156A	RF 62 1/4W J	C117	OB09876A	CMM 0.47μ 50V J	R154,155	OB09701A	RK 10K 1/6W J	Q225	OB06299A	TR 2SC2878	IC607	OB1369A	IC TA64	R673	OB05625A	RK 220K 1/4W J
C160	OB41386A	CPP 100P 50V J	C118,119	OB09187A	CE 1μ 50V (BP)	R156	OB09709A	RK 22K 1/6W J	D310	OB06398A	SID 1SS176	IC608	OB1368A	IC LB1649	R674	OB09733A	RK 220K 1/6W J
C161,162	OB41133A	CPP 2200P 100V G	C120	OB05681A	CE 10μ 16V (BP)	R157	OB09713A	RK 33K 1/6W J	R715	OB09693A	RK 4.7K 1/6W J	Q602,603	OB10007A	TR 2SC3399	R675,676	OB09737A	RK 330K 1/6W J
C163	OB41139A	CPP 3900P 100V G	C121	OB40473A	CE 10μ 16V (BP)	R158	OB09733A	RK 220K 1/6W J	R716	OB01889A	RK 100K 1/4W J	Q604	OB10007A	TR 2SC3399	R677,678	OB09737A	RK 330K 1/6W J
C164	OB41143A	CPP 5600P 100V G	C122	OB41388A	CPP 120P 50V J	R159	OB05936A	RK 10 1/4W J	R717	OB09725A	RK 100K 1/6W J	Q605	OB06299A	TR 2SC2878	R679	OB09701A	RK 10K 1/6W J
C165,166	OB09187A	CE 1μ 50V (BP)	C123,124	OB40473A	CE 10μ 16V (BP)	R160	OB22229A	RM 1.00K 1/6W F	R718	OB24155A	RF 12 1/4W J	Q606	OB10003A	TR 2SA1345	R680	OB09749A	RK 1M 1/6W J
C167	OB05813A	CML 0.056μ 50V J	C201	OB09148A	CE 10μ 25V (LN)	R161	OB22248A	RM 1.54K 1/6W F	R815	OB09693A	RK 4.7K 1/6W J	Q608,609	OB10033A	TR 2SC1740S	R681	OB09735A	RK 270K 1/6W J
C168	OB05682A	CML 0.068μ 50V J	C203	OB09404A	CPP 1000P 100V J	R162	OB22296A	RM 3.92K 1/6W F	R816	OB01889A	RK 100K 1/4W J	Q610,611	OB10033A	TR 2SC1740S	R682	OB09611A	RK 1.8 1/6W J
C169	OB41300A	CMM 0.15μ 50V J	C204,205	OB41133A	CPP 2200P 100V G	R163	OB22431A	RM 59.0K 1/6W F	R817	OB09725A	RK 100K 1/6W J	Q612,613	OB10033A	TR 2SC1740S	R683	OB09623A	RF 5.6 1/6W J
C170	OB41302A	CMM 0.22μ 50V J	C207,208	OB09792A	CC 33P 50V J	R164	OB09733A	RK 220K 1/6W J	R818	OB24155A	RF 12 1/4W J	Q614,615	OB10029A	TR 2SA933S	R684	OB09669A	RK 470 1/6W J
C171	OB09876A	CMM 0.47μ 50V J	C209	OB09393A	CC 68P 50V J	R250	OB09681A	RK 1.5K 1/6W J	C330,331	OB01403A	CE 47μ 16V	Q616,617	OB10029A	TR 2SA933S	R685	OB09689A	RK 3.3K 1/6W J
C172	OB05557A	CML 0.01μ 50V J	C210	OB41139A	CPP 3900P 100V G	R251	OB09675A	RK 820 1/6W J				Q618,619	OB06013A	TR 2SA733 (P,Q)	R686	OB09697A	RK 6.8K 1/6W J
C173	OB05681A	CML 0.01μ 50V J	C211	OB41143A	CPP 5600P 100V G	R253	OB09703A	RK 12K 1/6W J				Q620,621	OB01872A	TR 2SC945L (P,Q)	R687	OB09689A	RK 3.3K 1/6W J
C174	OB40473A	CE 10μ 16V (BP)	C212	OB05557A	CML 0.015μ 50V J	R254,255	OB09701A	RK 10K 1/6W J				Q622	OB01872A	TR 2SC945L (P,Q)	R688	OB09707A	RK 18K 1/6W J
C260	OB41386A	CPP 100P 50V J	C213	OB05682A	CML 0.068μ 50V J	R256	OB09709A	RK 22K 1/6W J	Q301	OB06202A	TR 2SA562TM (Y)	Q625	OB10033A	TR 2SC1740S	R689	OB09719A	RK 56K 1/6W J
C261,262	OB41133A	CPP 2200P 100V G	C214	OB41300A	CMM 0.15μ 50V J	R257	OB09713A	RK 33K 1/6W J	Q302	OB10029A	TR 2SA933S	Q626	OB10029A	TR 2SA933S	R690	OB09721A	RK 68K 1/6W J
C263	OB41139A	CPP 3900P 100V G	C215	OB05813A	CML 0.056μ 50V J	R258	OB09733A	RK 220K 1/6W J	D302	OB06398A	SID 1SS176	Q628	OB10029A	TR 2SA933S	R691	OB09681A	RK 1.5K 1/6W J
C264	OB41143A	CPP 5600P 100V G	C216	OB41302A	CMM 0.22μ 50V J	R259	OB05936A	RK 10 1/4W J	L301	OB51256A	Bias Osc. B01-JF	Q634	OB10097A	TR 2SA952 (K,L)	R692,693	OB09713A	RK 33K 1/6W J
C265,266	OB09187A	CE 1μ 50V (BP)	C217	OB09876A	CMM 0.47μ 50V J	R260	OB22229A	RM 1.00K 1/6W F	VR115	OB32127A	Semi VR 10K	Q634	OB12179A	ZD 15V	R694	OB09695A	RK 5.6K 1/6W J
C267	OB05813A	CML 0.056μ 50V J	C218,219	OB09187A	CE 1μ 50V (BP)	R261	OB22248A	RM 1.54K 1/6W F	VR116	OB32128A	Semi VR 20K	ZD601	OB12167A	ZD 10V	R695	OB09670A	RK 5.6K 1/6W J
C268	OB05682A	CML 0.068μ 50V J	C220	OB05681A	CML 0.01μ 50V J	R262	OB22296A	RM 3.92K 1/6W F	VR117	OB32129A	Semi VR 50K	ZD603	OB12150A	ZD 5.6V	R696,697	OB09670A	RK 5.6K 1/6W J
C269	OB41300A	CMM 0.15μ 50V J	C221	OB40473A	CE 10μ 16V (BP)	R263	OB22431A	RM 59.0K 1/6W F	VR215	OB32127A	Semi VR 10K	ZD604	OB12153A	ZD 6.2V	R698	OB01857A	RK 1K 1/4W J
C270	OB41302A	CMM 0.22μ 50V J	C222	OB41388A	CPP 120P 50V J	R264	OB22431A	RM 59.0K 1/6W F	VR216	OB32128A	Semi VR 10K				R699	OB09677A	RK 1K 1/6W J
C271	OB09876A	CMM 0.47μ 50V J	C223,224	OB40473A	CE 10μ 16V (BP)	C140	OB09322A	CPP 330P 100V J	VR217	OB32129A	Semi VR 50K				R936,937	OB09701A	RK 10K 1/6W J
C272	OB05557A	CML 0.015μ 50V J	C301,302	OB01391A	CE 220μ 25V	C141	OB09270A	CPP 470P 100V J	R330	OB09669A	RK 470 1/6W J	ZD604	OB12153A	ZD 6.2V	C415	OB01403A	CE 47μ 16V
C273	OB05681A	CML 0.01μ 50V J	C303	OB01674A	CE 10μ 25V	C142	OB09834A	CPP 2200P 100V J	R331,332	OB09693A	RK 4.7K 1/6W J				C601,602	OB09223A	CE 1μ 50V (LN)
C274	OB40473A	CE 10μ 16V (BP)	CN33	OB81634A	2P-T Post	C143	OB05687A	CML 1200P 50V J	R336	OB09701A	RK 10K 1/6W J	D608	OB06398A	SID 1SS176	C603	OB09223A	CE 1μ 50V (LN)
C320	OB01391A	CE 220μ 25V	CN39,40	OB81635A	3P-T Post	C144	OB09828A	CPP 8200P 100V J	R337	OB05622A	RK 2.2K 1/4W J	D609,610	OB06398A	SID 1SS176	C604	OB09327A	CE 0.33μ 50V (LN)
C325	OB01391A	CE 220μ 25V			C145	OB05685A	CML 0.082μ 50V J	R338,339	OB09721A	RK 68K 1/6W J	D611,612	OB06398A	SID 1SS176	C605	OB09222A	CE 0.47μ 50V (LN)	
CN34	OB81635A	3P-T Post			C146	OB09814A	CE 1μ 50V (LN)	R341,342	OB09725A	RK 100K 1/6W J	D613	OB06398A	SID 1SS176	C606	OB09332A	CE 2.2μ 50V (LN)	
					C147	OB40154A	CE 47μ 16V (LN)		OB09733A	RK 220K 1/6W J	D614,615	OB12584A	SID 1N4148	C607	OB09148A	CE 10μ 25V (LN)	
					C240	OB09322A	CPP 330P 100V J		OB09737A	RK 220K 1/6W J	D617	OB06398A	SID 1SS176	C608,609	OB09150A	CE 33μ 25V (LN)	
					C241	OB09270A	CPP 470P 100V J		OB24158A	RF 10 1W J	D618,619	OB06398A	SID 1SS176	C610	OB01412A	CE 10μ 16V	
					C242	OB09834A	CPP 2200P 100V J		OB24159A	RF 22 1W J	D620,621	OB06398A	SID 1SS176	C611	OB05841A	CE 330μ 10V	
					C243	OB05687A	CML 1200P 50V J		OB09717A	RK 47K 1/6W J	D622,623	OB06398A	SID 1SS176	C612	OB40079A	CE 220μ 16V	

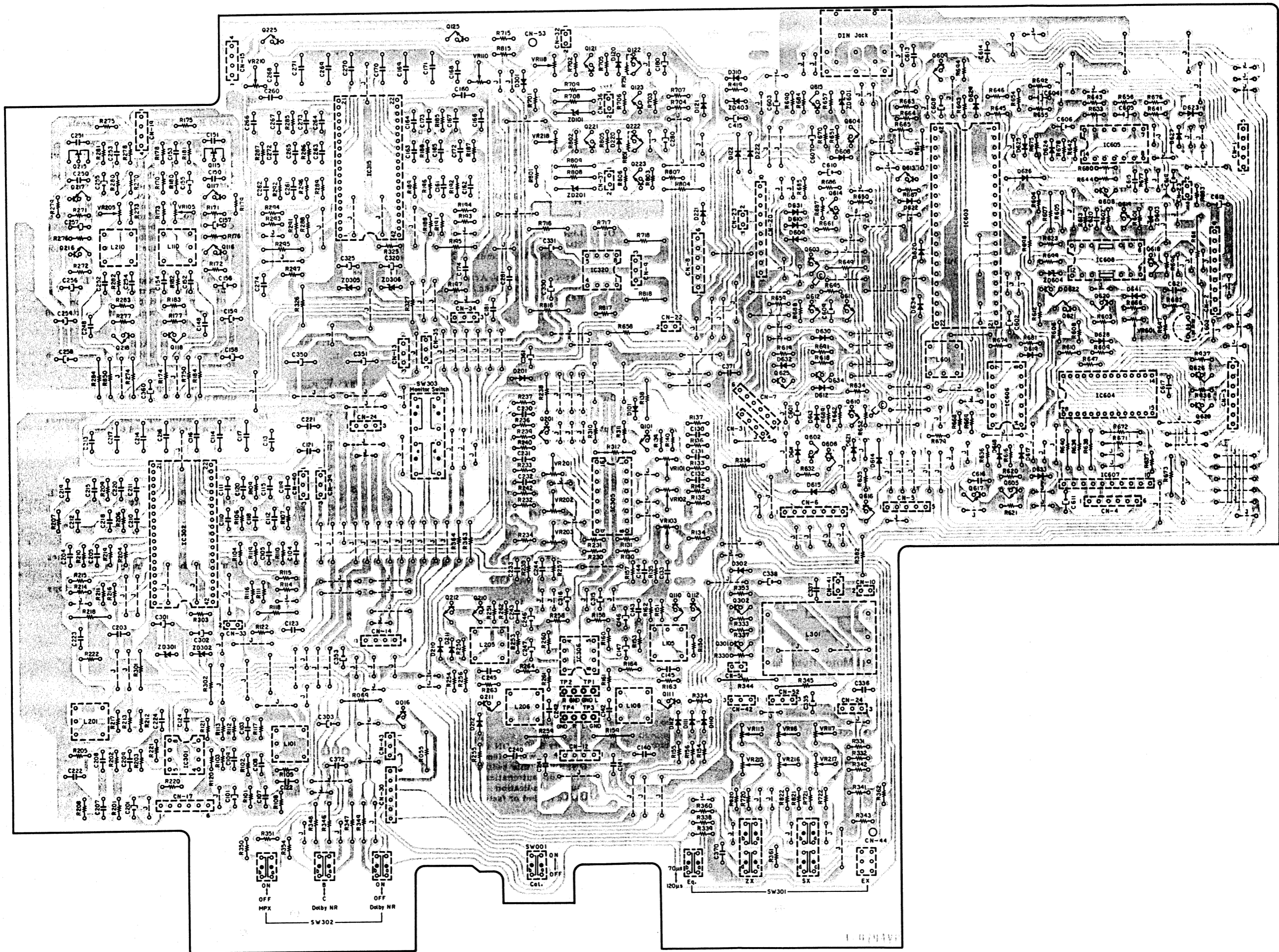

Fig. 8.13.2 Serial Nos.: A13101001 - 02450 (CR-4A)
A13150001 - 53800 (CR-4/4E/40)

9. SCHEMATIC DIAGRAMS

9.1. IC Block Diagrams

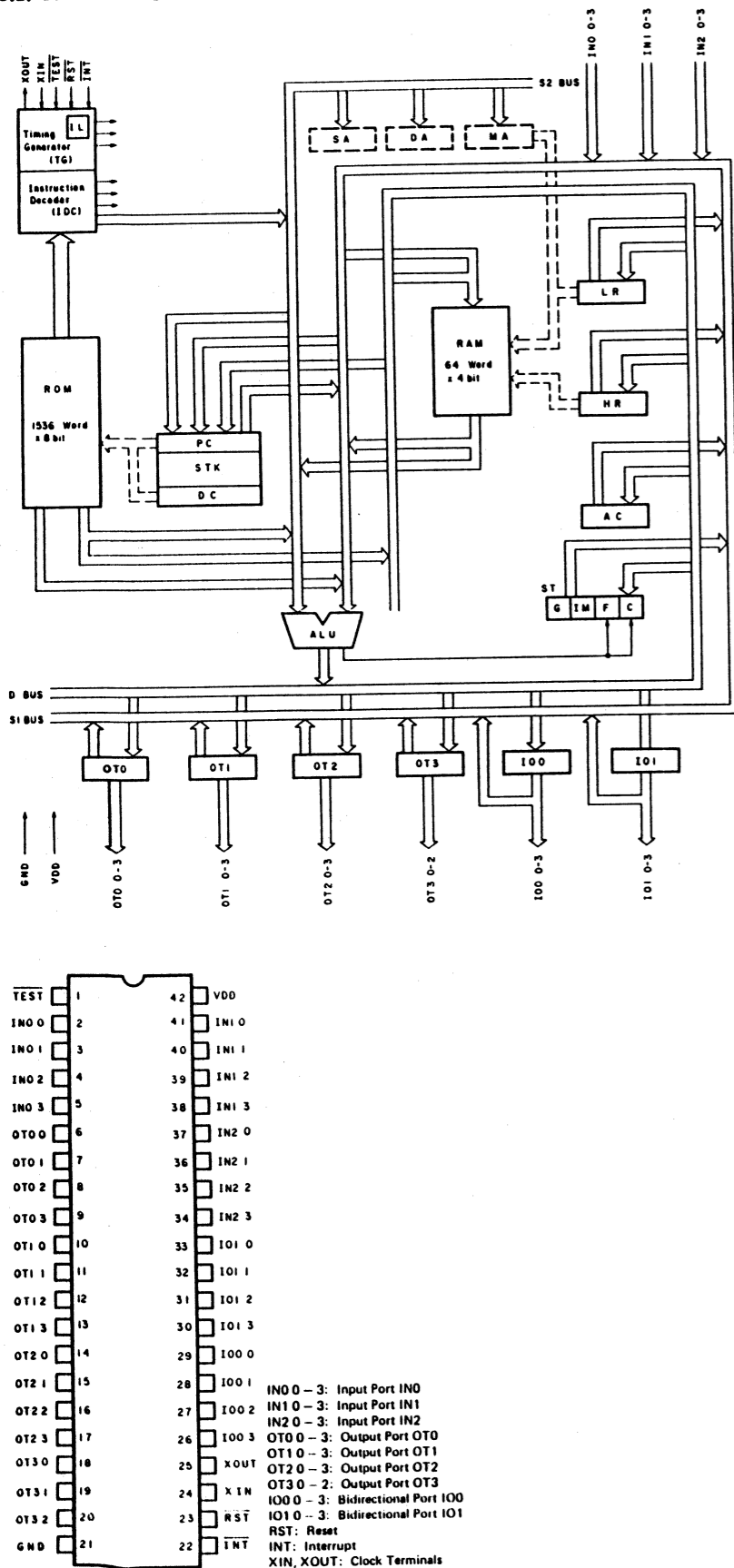

Fig. 9.1.1 4-Bit Micro-processor TMP4315BP-1814

IC603 (TMP4315BP-1814)

Pin No.	Signal Name	In/Out	Function
1	Test	—	Not used.
2	Cam (0)	In	Mechanism position detecting signals.
3	Cam (1)	In	Mechanism mode can be sensed according to states of Cam (0), Cam (1) and Cam (2).
4	Cam (2)	In	
5	Eject	In	Eject signal. Active L. Used to detect whether the Cassette Case is open. When it is open, this signal is L. In this condition, the CR-4 is in Stop mode and no pushbutton operation is enabled.
6	R.M. Fwd.	Out	Reel Motor Forward signal. Active L.
7	R.M. Rev.	Out	Reel Motor Reverse signal. Active L.
8	C.M. Fwd.	Out	Control Motor Forward signal. Active L.
9	C.M. Rev.	Out	Control Motor Reverse signal. Active L.
10	R.M. Play	Out	Reel Motor Play signal. Active H. In Play mode, C.M. Fwd. becomes L, and R.M. Play becomes H.
11	Capstan M	Out	Not used.
12	E. Brake	Out	Electric Brake signal. Active H. Generates H pulse upon change in mode.

Pin No.	Signal Name	In/Out	Function
13	Source Mute	Out	Source Mute signal. Active H. Issues H pulse for 3.3 sec after power is turned ON. Used for timer recording circuit.
14	Line Mute	Out	Line Output Mute signal. Active H. Stays at L only in Play or Rec./Play mode. Deactivates mute of line outputs.
15	Rec. Mute	Out	Record Mute signal. Active H. Stays at L only in Rec./Play mode. Releases record mute.
16	Rew. Mode	Out	Rewind Mode signal. Active L.
17	F.F. Mode	Out	F.F. Mode signal. Active L.
18	Pause Mode	Out	Pause Mode signal. Active L. Used for lighting of Pause lamp.
19	Play Mode	Out	Play Mode signal. Active L. Used for lighting of Play lamp.
20	Rec. Mode	Out	Record Mode signal. Active L. Used for lighting of Record lamp.
21	Vss	In	GND.
22	INT	In	Interrupt signal. Active L. Allows input of shut-off pulse train. Detects tape running, i.e., rotation of Take-up Reel Hub.
23	Reset	In	Reset signal. Active L. Held at L for approx. 100 msec after power is turned ON. Upon change of this signal to H, IC603 starts operation.
24	EXtal	In	External circuit for clock oscillation.
25	Xtal	In	Oscillating frequency = 550 kHz.
26	Rec.	—	Not used.
27	AMS	—	Not used.
28	Zero	In	Not used.
29	Memory	In	Memory Switch ON signal. Active H. Held at H when Memory switch is set to ON. (With this switch set to ON, tape will stop automatically when the tape counter indication "000" is reached during rewind or fast-forward.)

Pin No.	Signal Name	In/Out	Function
30	A. Rew.	In	Auto Rewind and Auto Play signals. Active L.
31	A. Play	In	These signals are L when Timer switch is set to OFF and, at the same time, Auto Repeat switch is set to ON. (With these signals set to L, auto repeat function is performed and the playback/rewind cycle is continuously repeated between the tape end and the tape start. Furthermore, if Memory switch is set to ON, the playback/rewind cycle is continuously repeated between the tape end and the tape counter indication "000".)
32	T. Rec.	In	Timer Recording signal. Active L. When power is turned ON with Timer switch in Record position, becomes L for approx. 3.3 sec, causing unattended recording to start.
33	T. Play	In	Timer Play signal. Active L. Held at L upon setting of Timer switch to the Play position.
34	K. Pause	In	Pause button input terminal. Becomes L upon push of Pause button.
35	K. Rec.	In	Record button input terminal. Becomes L upon push of Record button.
36	R. Mute	—	Not used.
37	SEA	—	Not used.
38	K. Play	In	Play button input terminal. Becomes L upon push of Play button.
39	K. F.F.	In	F.F. button input terminal. Becomes L upon push of F.F. button.
40	K. Rew.	In	Rewind button input terminal. Becomes L upon push of Rewind button.
41	K. Stop	In	Stop signal input terminal. At L, stops all operations.
42	VDD	In	+5 V.

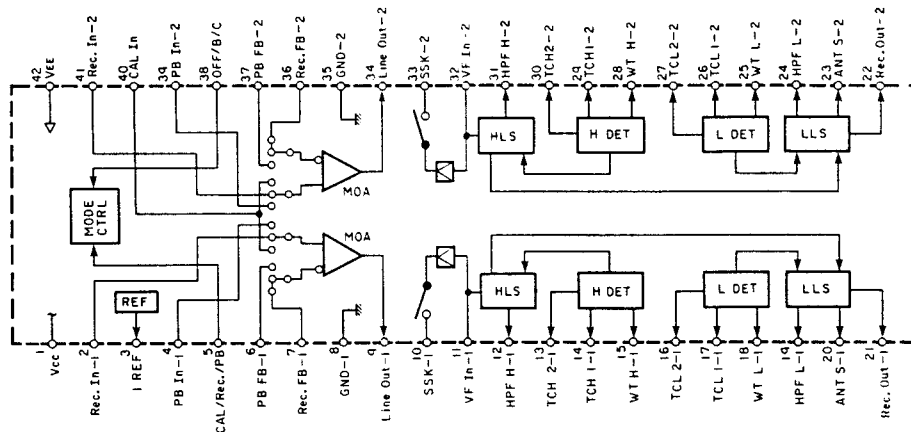

Fig. 9.1.3 Dolby NR IC CX20188

IC302/IC315 (CX20188)

Pin No.	Signal Name	Function
1	Vcc	Positive power supply input terminal.
2,41	Rec. In	Record signal input terminal.
3	I Ref.	Reference current input terminal.
4,39	PB In	PB signal input terminal.
5	CAL/Rec./PB	Calibration/Recording/Playback select terminal.
6,37	PB FB	Playback signal feedback terminal.
7,36	Rec. FB	Record signal feedback terminal.
8,35	GND	GND terminal.
9,34	Line Out	Line signal (decoded signal) output terminal.
10,33	SSK	Spectral skewing switch terminal.
11,32	VF In	Encode circuit input terminal.
12,31	HPF H	HLS high-pass filter terminal.
13,30	TCH 2	HLS detector time constant determination terminal 2.
14,29	TCH 1	HLS detector time constant determination terminal 1.
15,28	WT H	HLS weighting terminal.
16,27	TCL 2	LLS detector time constant determination terminal 2.
17,26	TCL 1	LLS detector time constant determination terminal 1.
18,25	WT L	LLS weighting terminal.
19,24	HPF L	LLS high-pass filter terminal.
20,23	ANT S	Anti-saturation terminal.
21,22	Rec. Out	Record signal (encoded signal) output terminal.
38	OFF/B/C	Dolby NR OFF/B-type/C-type select terminal.
40	CAL In	Calibration input terminal. Not used.
42	VEE	Negative power supply input terminal.

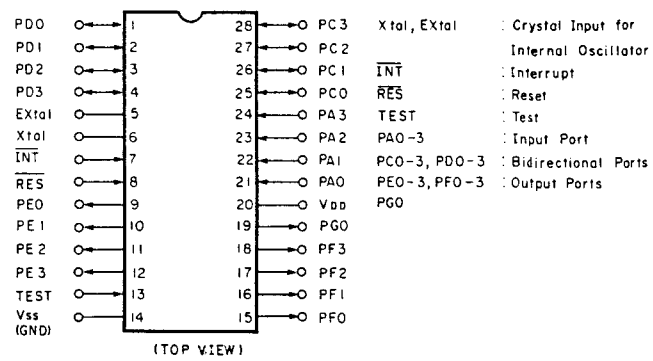
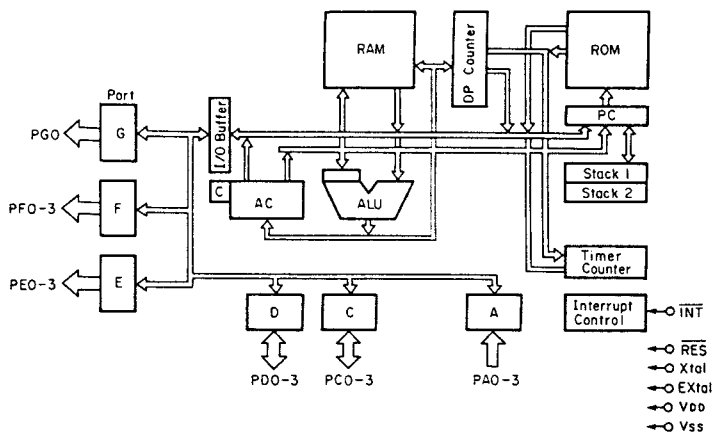
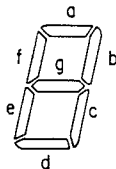

Fig. 9.1.2 4-Bit Micro-processor LM6416E-106

IC604 (LM6416E-106)

Pin No.	Signal Name	In/Out	Function
1	CLR	In	Reset button input terminal. Upon push of Reset button, Reset signal becomes L and counter is cleared to "0000".
2	K. Play	In	Play button input terminal. Becomes L upon push of Play button.
3	K. F.F.	In	F.F. button input terminal. Becomes L upon push of F.F. button.
4	K. Rew.	In	Rewind button input terminal. Becomes L upon push of Rewind button.
5	EXtal	In	Terminals for clock oscillation, RC circuit is connected.
6	Xtal	In	
7	INT	In	Interrupt signal. Active L. Shut-off pulse train is input. Input pulse train is counted for tape counter display.
8	Reset	In	Reset signal. Active L. Held at L for approx. 100 msec after power is turned ON.
9	f	Out	Display segment drive signals. Segment lights at L.
10	b		
11	a		
12	d		
13	Test	In	Not used.
14	VSS	In	GND.
15	g	Out	Display segment drive signals. Segment lights at L.
16	a		
17	c		
18	D4	Out	The 4th (rightmost) digit select signal. Active L.



Pin No.	Signal Name	In/Out	Function
19	Motor Slow	Out	Motor Slow signal. Active L. When Motor Slow signal is L, reel motor speed is reduced.

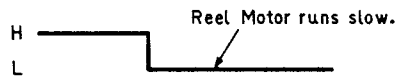

20	VDD	In	+5 V
21	L. Rew.	In	LED Rewind signal. Active L. When mode is changed to Rewind, L. Rew. signal becomes L after H period of E. Brake signal ended.

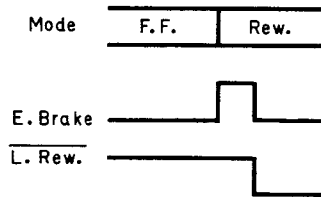

22	L. F.F.	In	LED F.F. signal. Active L. Timing is similar to L. Rew. signal.
23	L. Stop	In	LED Stop signal. Active L. Timing is similar to L. Rew. signal.
24	Memory Stop	In	Memory Stop switch input terminal of Memory Stop/Auto Repeat switch. Memory Stop signal is L when Memory Stop is selected.
25	Memory Play	In	Not used.
26	D3	Out	The 3rd, 2nd, and 1st (leftmost) digit select signals. Active L.
27	D2		
28	D1		

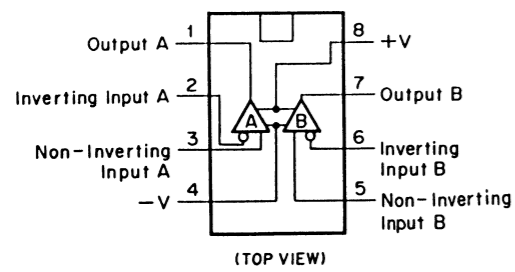

Fig. 9.1.4 Operational Amp. IC 4556D, 4558D, 4560M, 2043DD, 2403D, 072DE

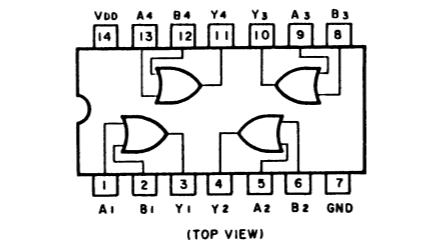

Fig. 9.1.5 OR Gate C-MOS IC μ PD4071BC

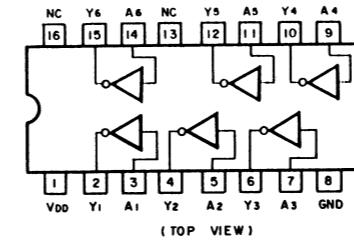

Fig. 9.1.9 Inverter C-MOS IC LC4049B

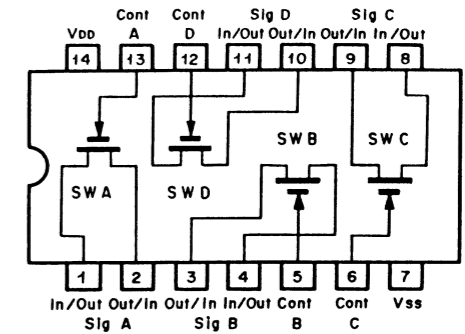

Fig. 9.1.10 Bilateral Switch μ PD4066BC

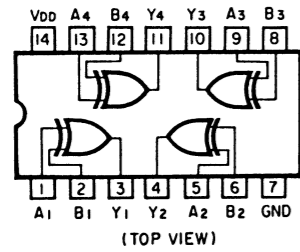

Fig. 9.1.6 Exclusive OR Gate C-MOS IC μ PD4030BC

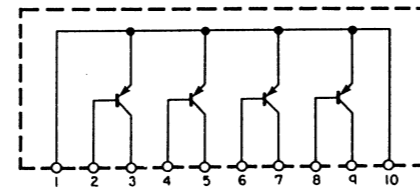
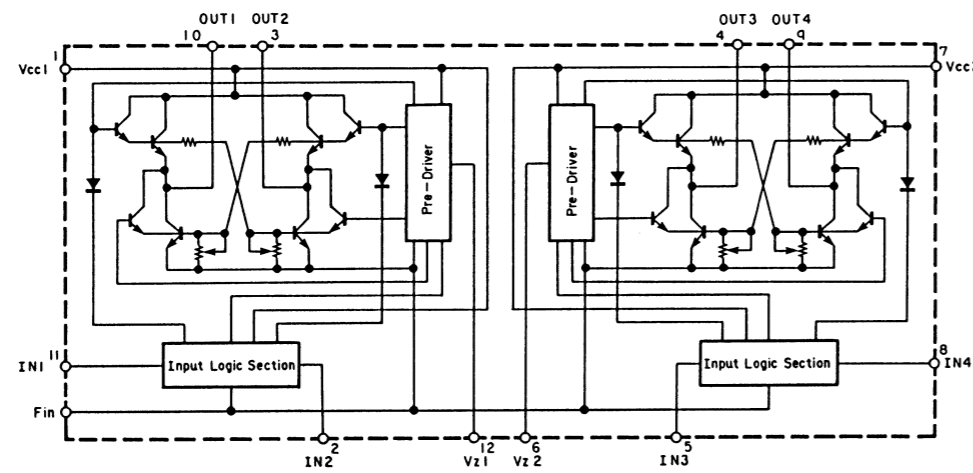

Fig. 9.1.7 Transistor Array TA64



INPUT		OUTPUT		OPERATION
IN1/3	IN2/4	OUT1/3	OUT2/4	
0	0	0	0	Braking
1	0	1	0	Forward (Reverse)
0	1	0	1	Reverse (Forward)
1	1	0	0	Braking

Fig. 9.1.8 Motor Driver IC LB1649

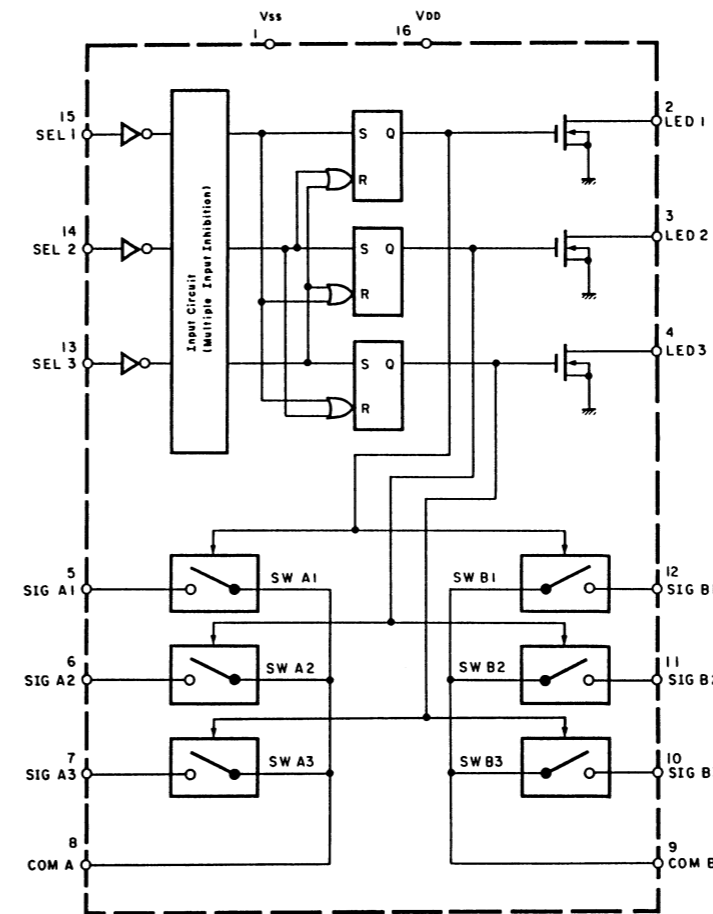

Fig. 9.1.11 Analog Switch Selector TC9145P

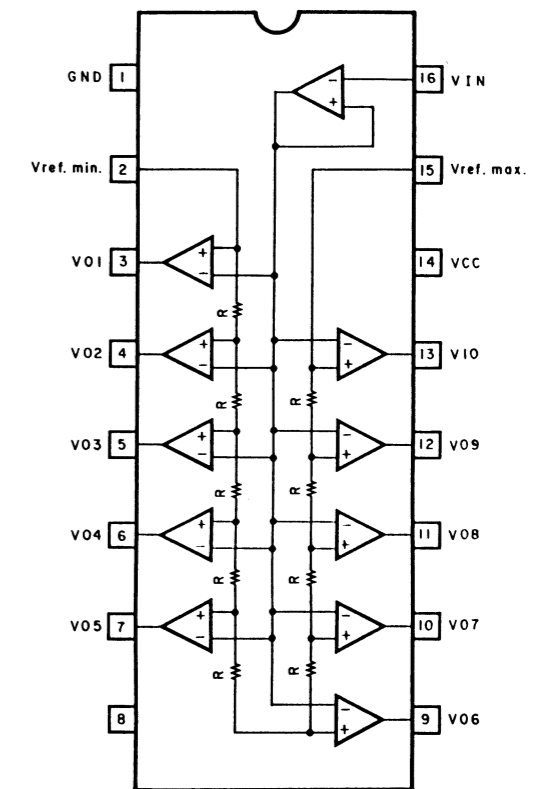

Fig. 9.1.12 Level Meter Driver TA7612AP

9.2. Schematic Diagrams

(1) For Serial No.: A13102451 - (CR-4A)/A13153801 - (CR-4/E/40)

CR-4/4A/4E/40

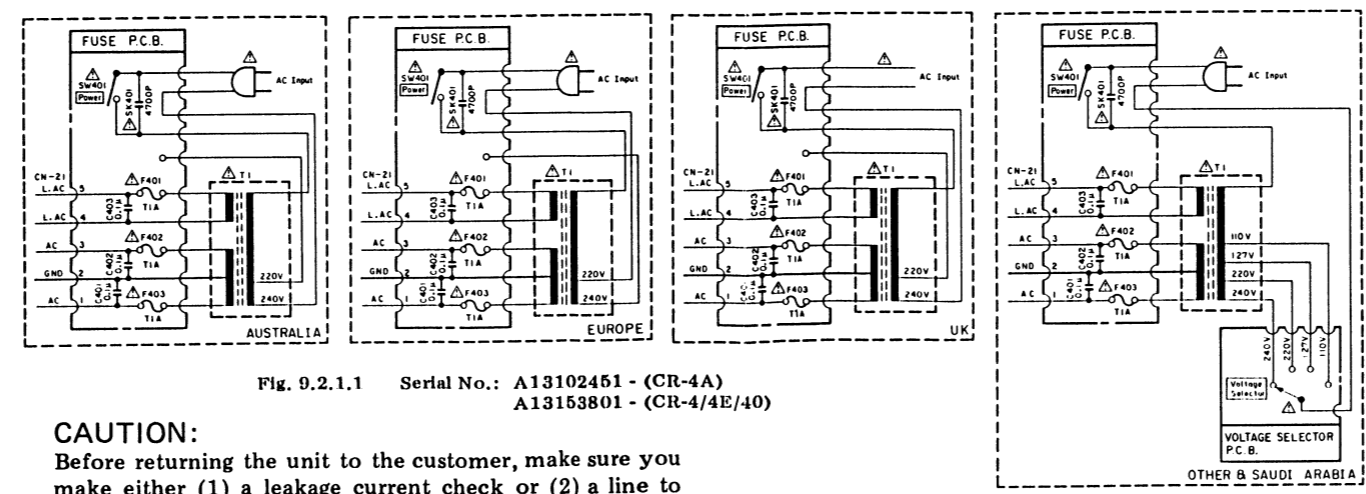
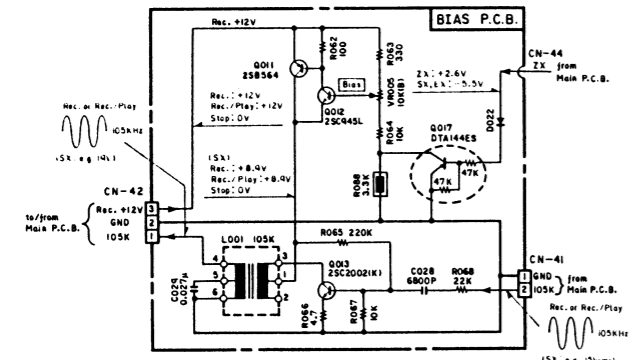
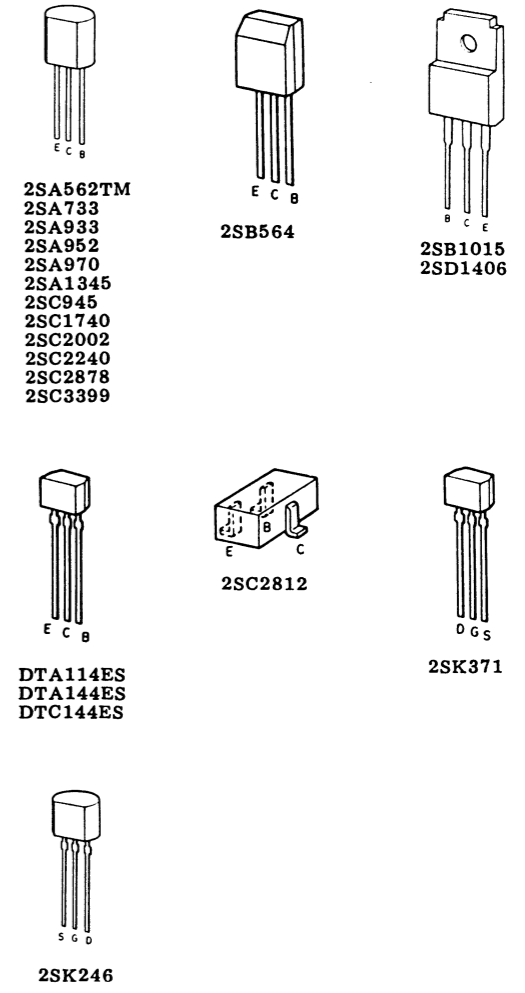
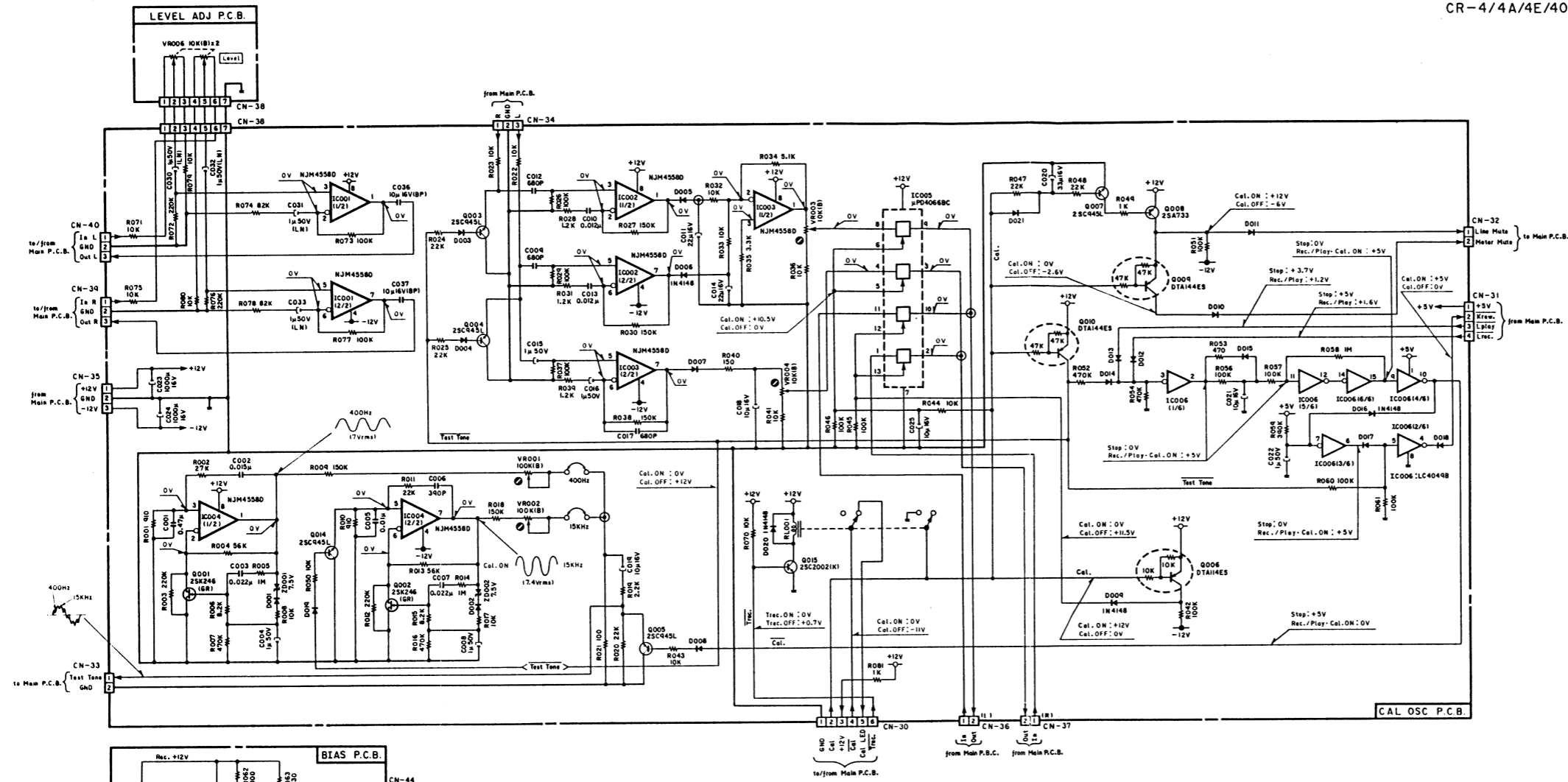

Fig. 9.2.1.1 Serial No.: A13102451 - (CR-4A) A13153801 - (CR-4/E/40)

WARNING:
Parts marked with the symbol have critical characteristics. Use ONLY replacement parts recommended by the manufacturer. It is recommended that the unit be operated from a suitable DC supply or batteries during initial check-out procedures.

CAUTION:
Before returning the unit to the customer, make sure you make either (1) a leakage current check or (2) a line to chassis resistance check. If the leakage current exceeds 0.5 milliamp, or if the resistance from chassis to either side of the power cord is less than 240 k ohms, the unit is defective. **WARNING — DO NOT** return the unit to the customer until the problem is located and corrected.

- Notes:
- Diode is 1SS53, 1S1555, or 1SS176 unless otherwise specified.
 - 2SA733, 2SA608SP, 2SA1048 and 2SA1175 are interchangeable with each other.
 - 2SC945, 2SC536SP, 2SC2458 and 2SC2785 are interchangeable with each other.
 - Voltage measuring condition:
 - Stop mode (with no input signal) unless otherwise specified.
 - Tape: SX position, Eq.: 70 μs
 - Monitor Switch: Tape
 - Timer Switch: OFF
 - Memory Stop/Auto Repeat Switch: OFF
 - MPX Switch: OFF
 - Dolby NR Switch: OFF
 - Cal. Switch: OFF
 - Play mode: Cassette with no tape played back.
 - ➡: Indicates record signal flow.
 - ⇨: Indicates playback signal flow.

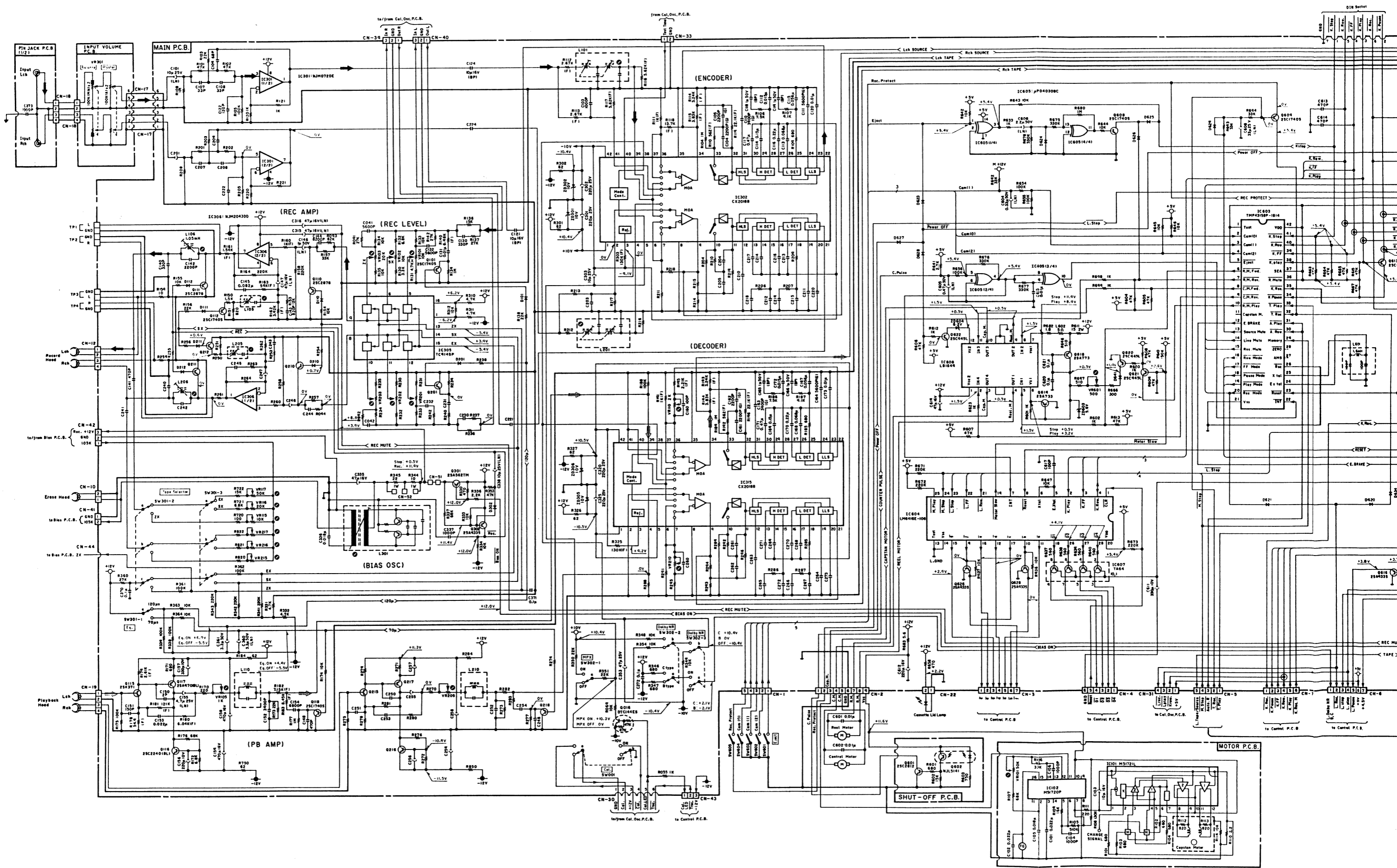

Fig. 9.2.1.2 Serial No.: A13102451 - (CR-4A)
A13153801 - (CR-4/4E/4D)

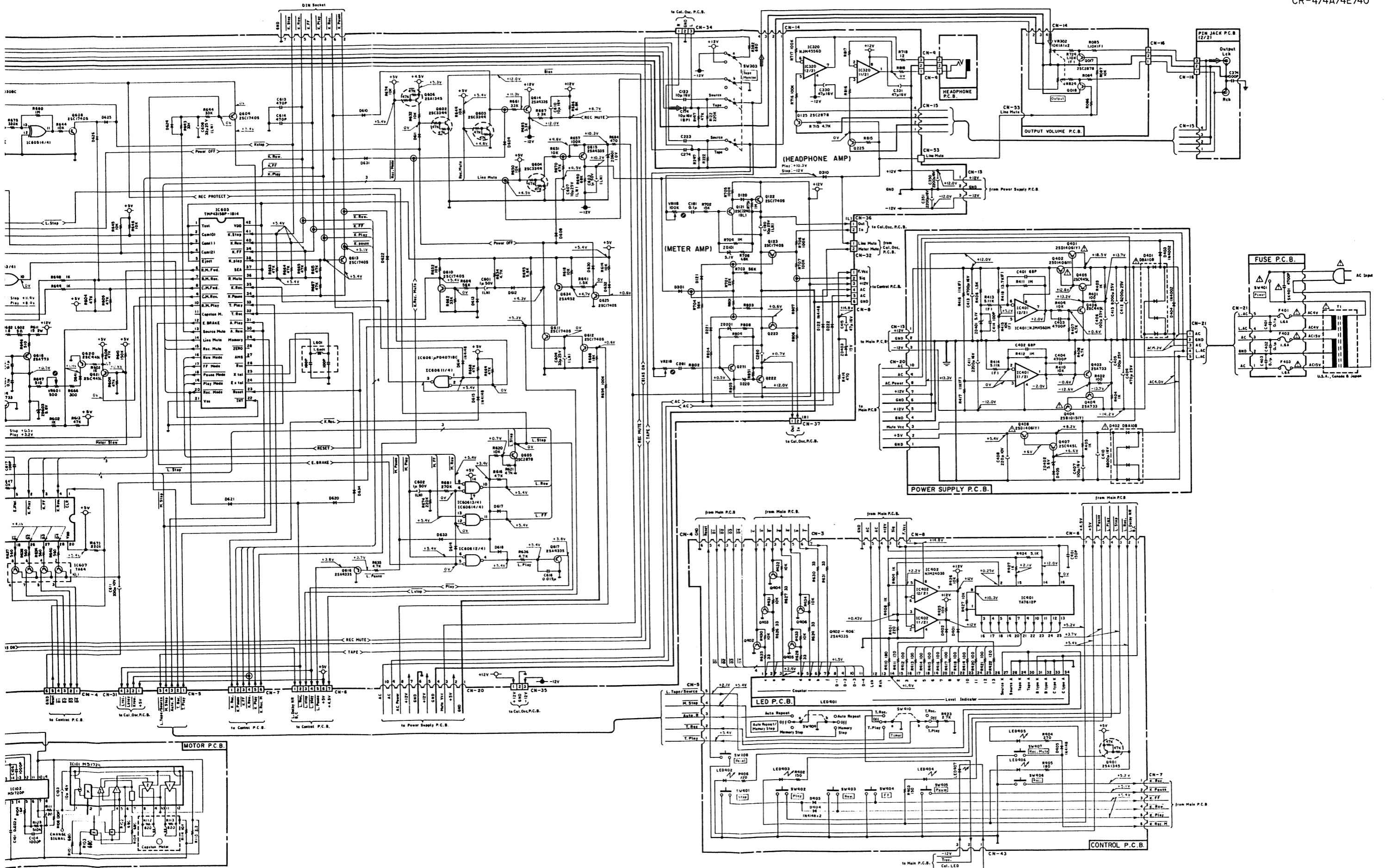

Fig. 9.2.1.2 Serial No.: A13102451 - (CR-4A)
A13153801 - (CR-4/4E/4O)

(2) For Serial Nos.: A13101001 - 02450 (CR-4A)/A13150001 - 53800 (CR-4/E/40)

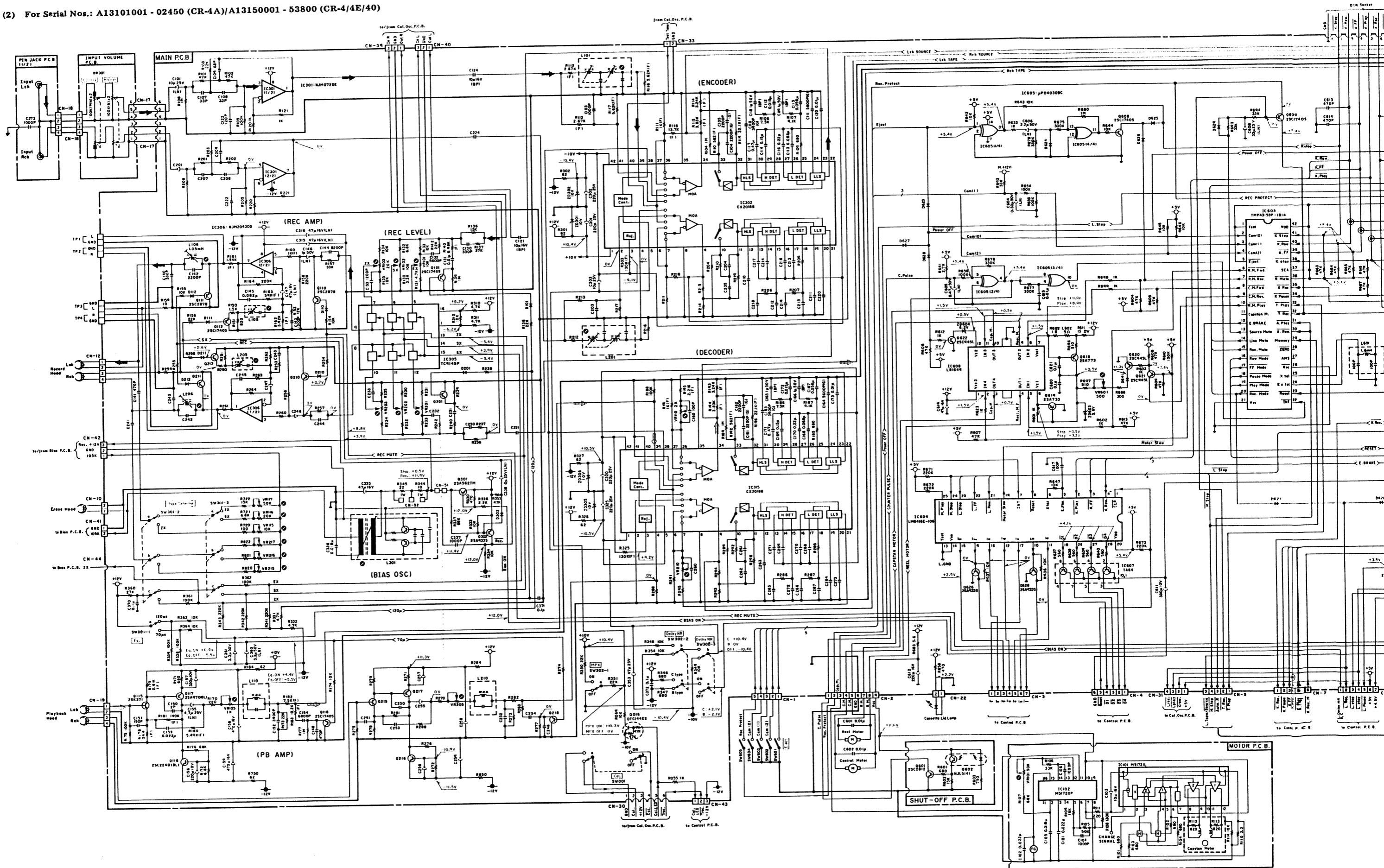

Fig. 9.2.2.1 Serial Nos.: A13101001 - 02450 (CR-4A)
A13150001 - 53800 (CR-4/E/40)

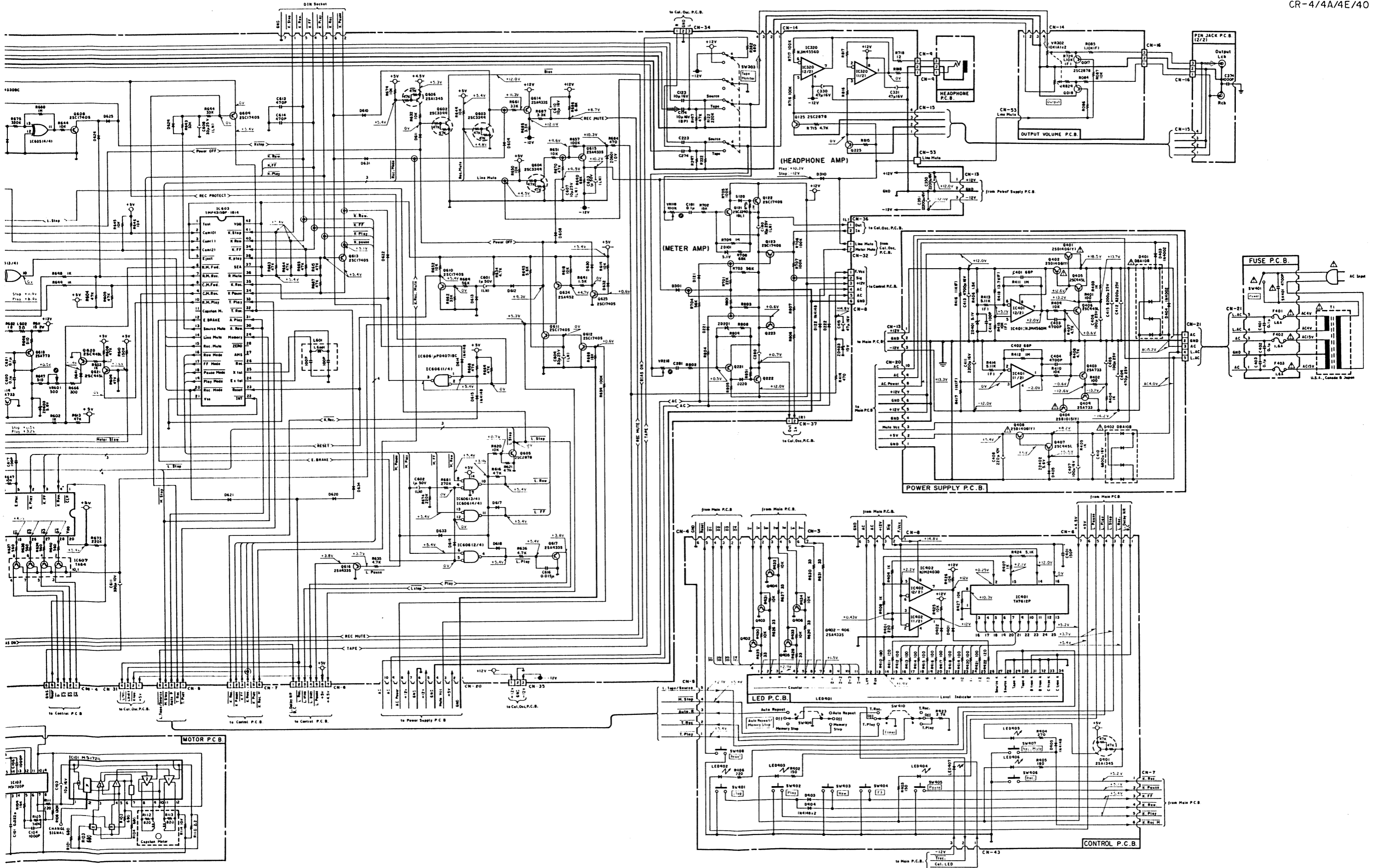
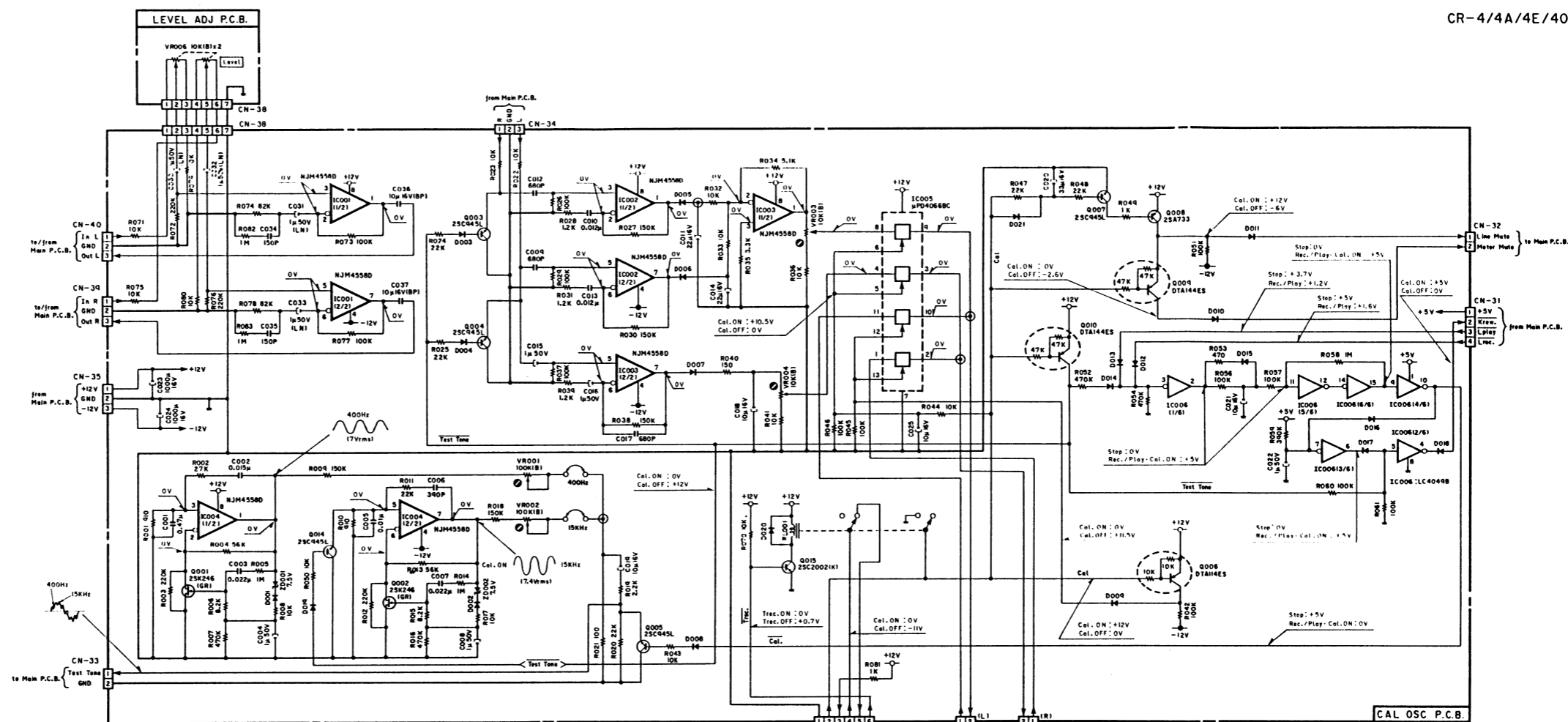
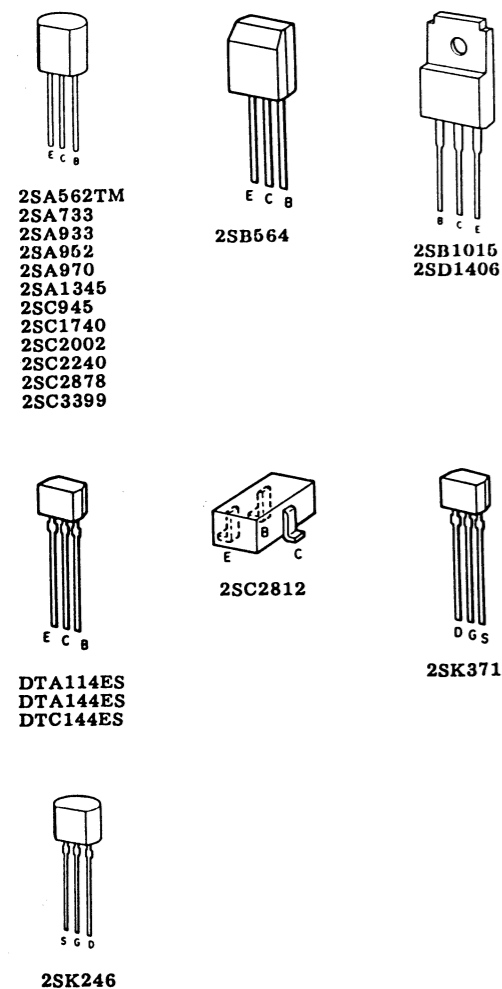

Fig. 9.2.2.1 Serial Nos.: A13101001 - 02450 (CR-4A)
 A13150001 - 53800 (CR-4/4E/40)



Notes:

- Diode is 1S553, 1S1555, or 1SS176 unless otherwise specified.
- 2SA733, 2SA608SP, 2SA1048 and 2SA1175 are interchangeable with each other.
- 2SC945, 2SC536SP, 2SC2458 and 2SC2785 are interchangeable with each other.
- Voltage measuring condition:
 - Stop mode (with no input signal) unless otherwise specified.
 - Tape: SX position, Eq.: 70 μ s
 - Monitor Switch: Tape
 - Timer Switch: OFF
 - Memory Stop/Auto Repeat Switch: OFF
 - MPX Switch: OFF
 - Dolby NR Switch: OFF
 - Cal. Switch: OFF
 - Play mode: Cassette with no tape played back.
- ➡: Indicates record signal flow.
 - ⇨: Indicates playback signal flow.

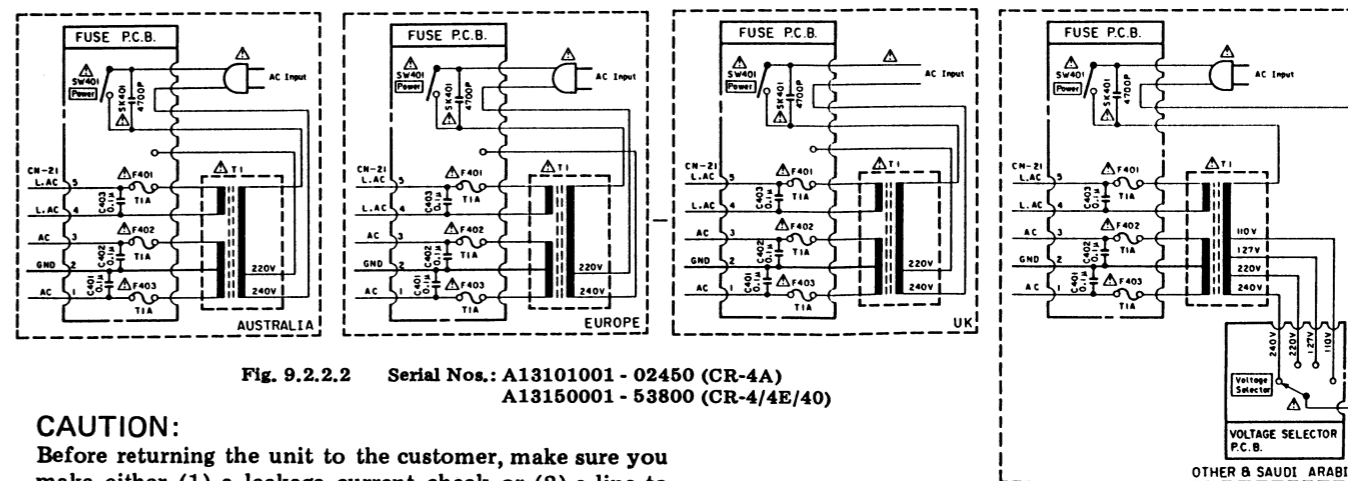
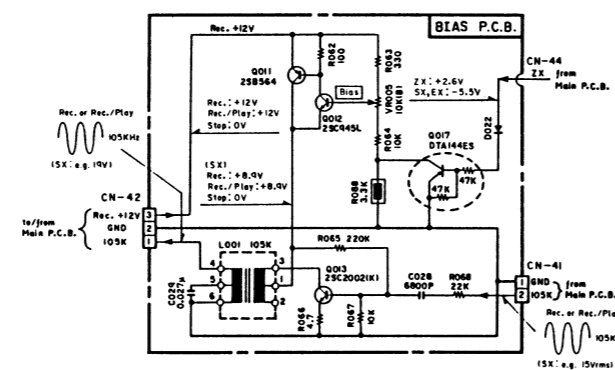

Fig. 9.2.2.2 Serial Nos.: A13101001 - 02450 (CR-4A)
A13150001 - 53800 (CR-4/E/4O)

WARNING:
Parts marked with the symbol have critical characteristics. Use ONLY replacement parts recommended by the manufacturer. It is recommended that the unit be operated from a suitable DC supply or batteries during initial check-out procedures.

CAUTION:
Before returning the unit to the customer, make sure you make either (1) a leakage current check or (2) a line to chassis resistance check. If the leakage current exceeds 0.5 milliamp, or if the resistance from chassis to either side of the power cord is less than 240 k ohms, the unit is defective. **WARNING — DO NOT** return the unit to the customer until the problem is located and corrected.

10. WIRING DIAGRAM

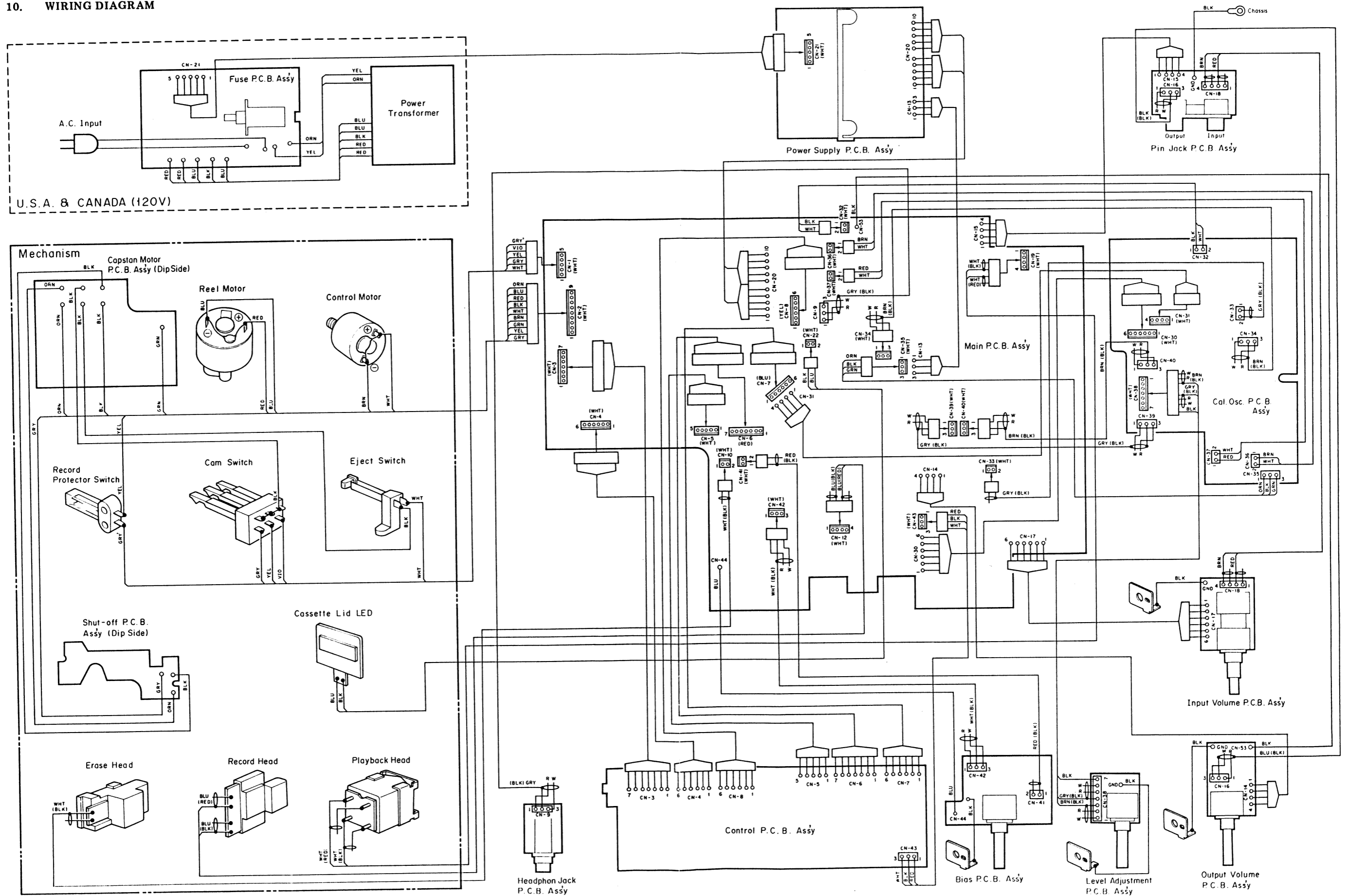
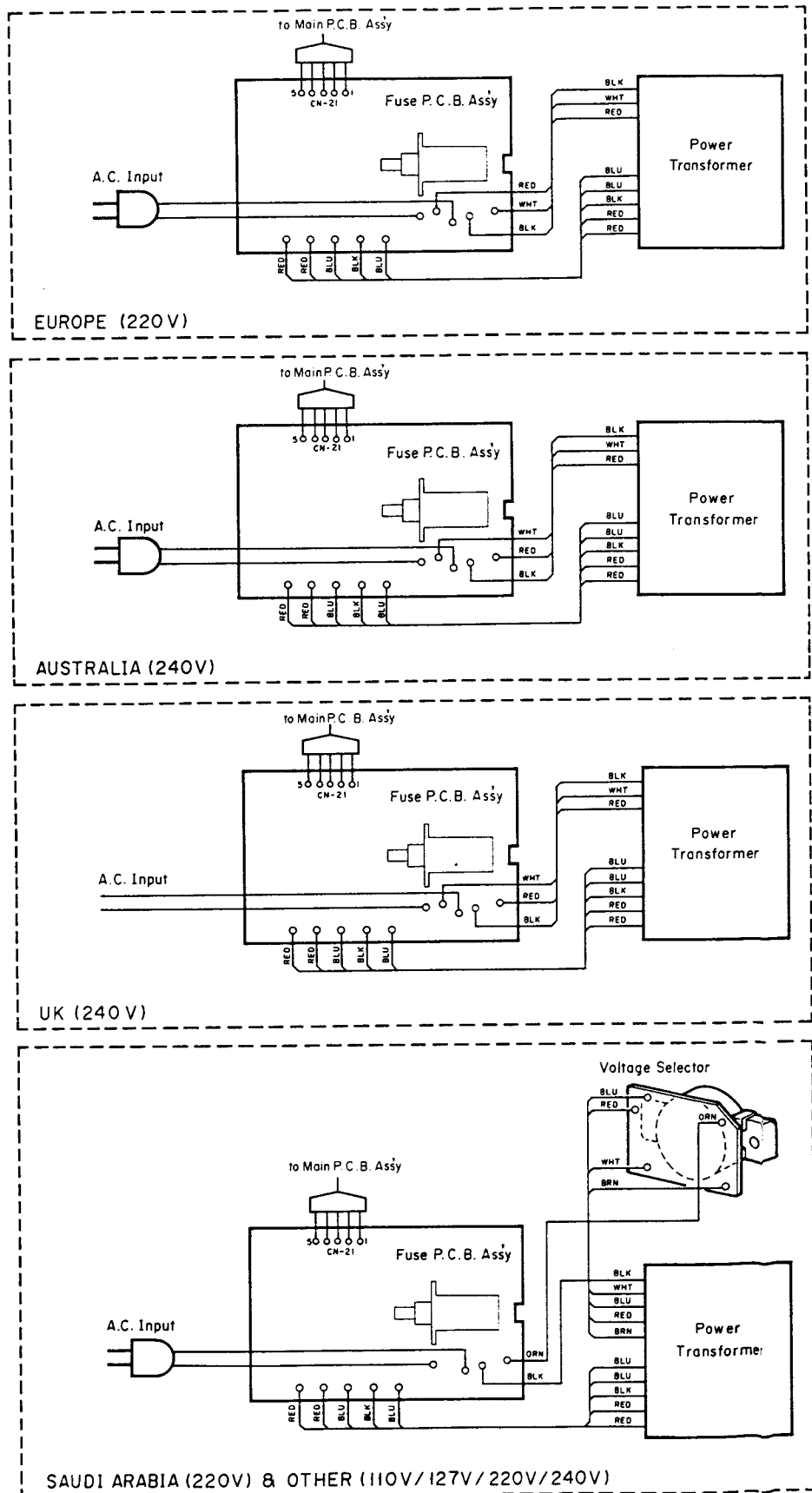

Fig. 10.1



- Notes: 1. Table of wire colors
 BRN — Brown
 RED — Red
 ORN — Orange
 YEL — Yellow
 GRN — Green
 BLU — Blue
 VIO — Violet
 GRY — Gray
 WHT — White
 BLK — Black
2. Component side view of the P.C.B. is illustrated unless otherwise specified.
3. Wire tube color is shown in ().

Fig. 10.2

11. BLOCK DIAGRAMS

11.1. Amplifier Section

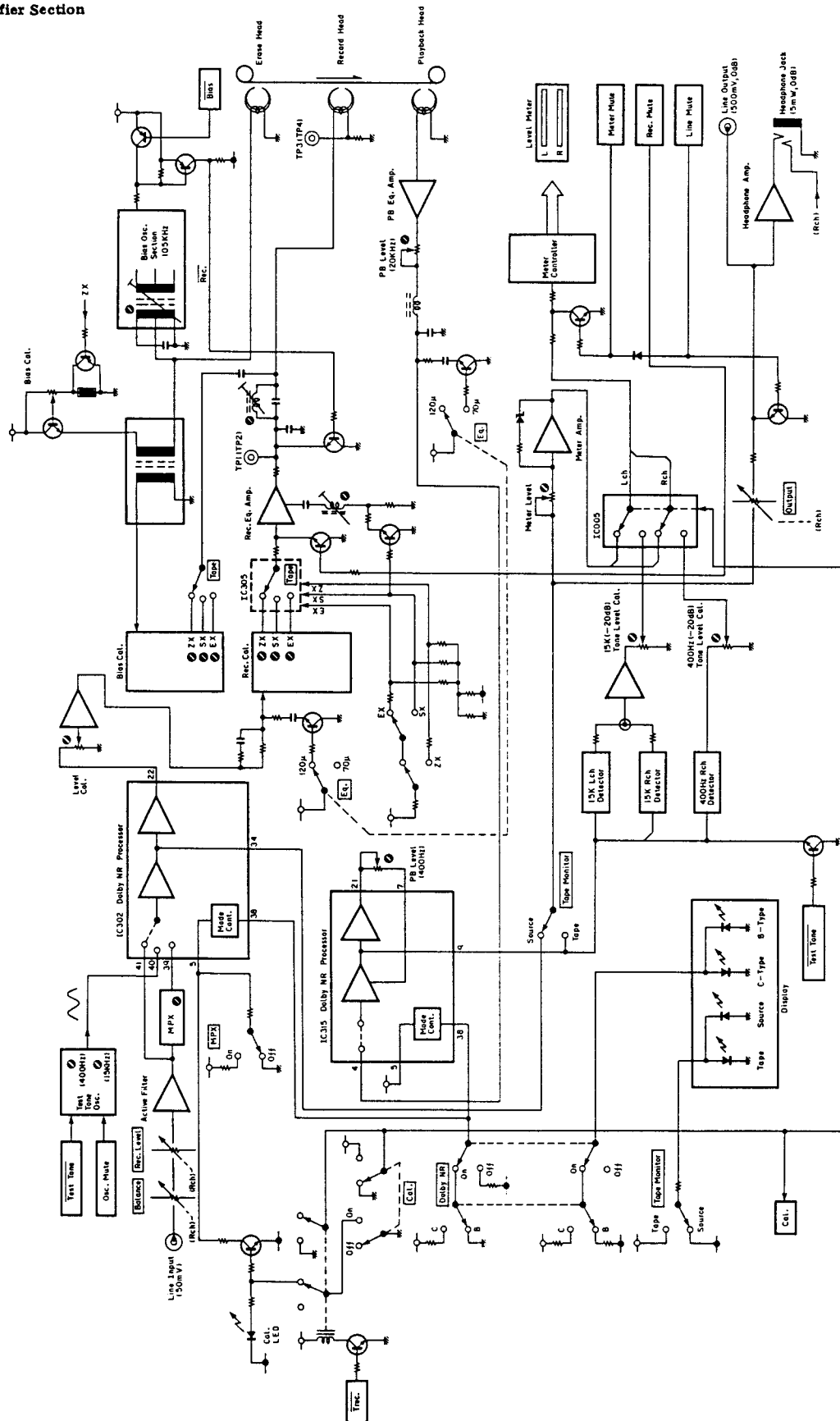

Fig. 11.1

11.2. Mechanism Control Section

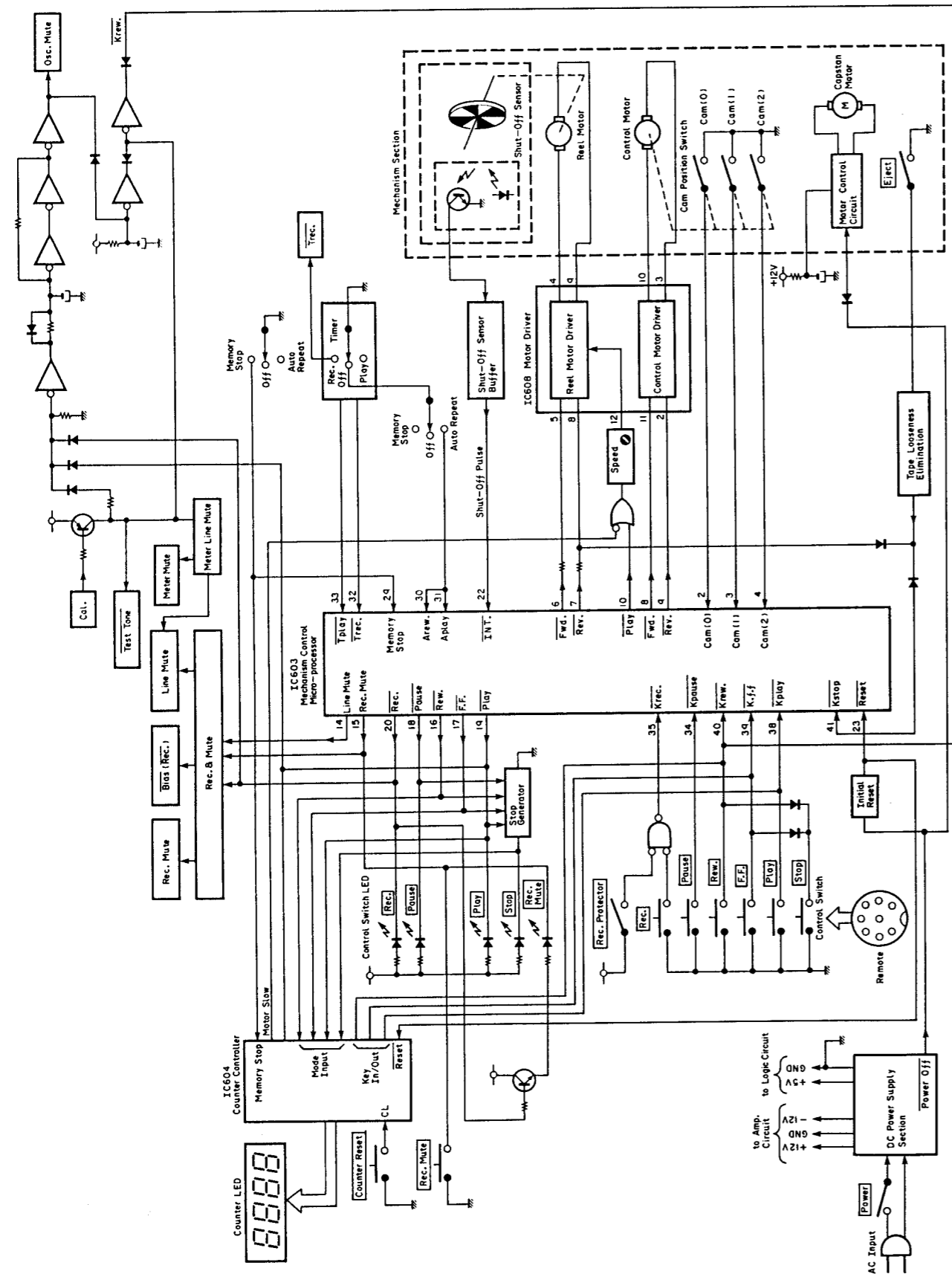

Fig. 11.2

12. TIMING CHARTS AND EQ. AMP. FREQUENCY RESPONSE

12.1. Timing Charts
(1) Overall Timing Charts

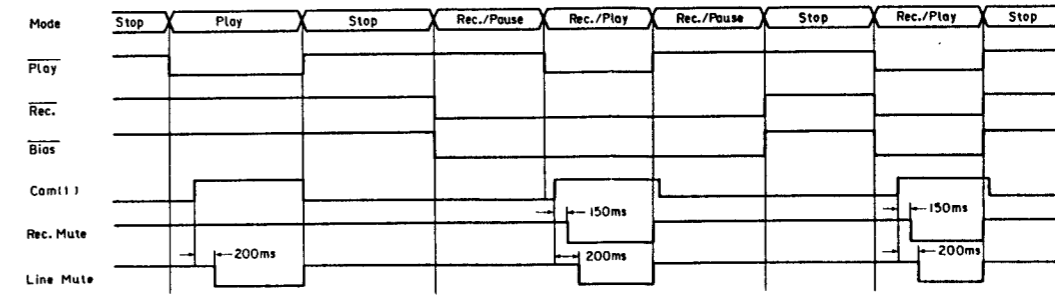

Fig. 12.1.1

(2) Mechanism Control Timing Charts

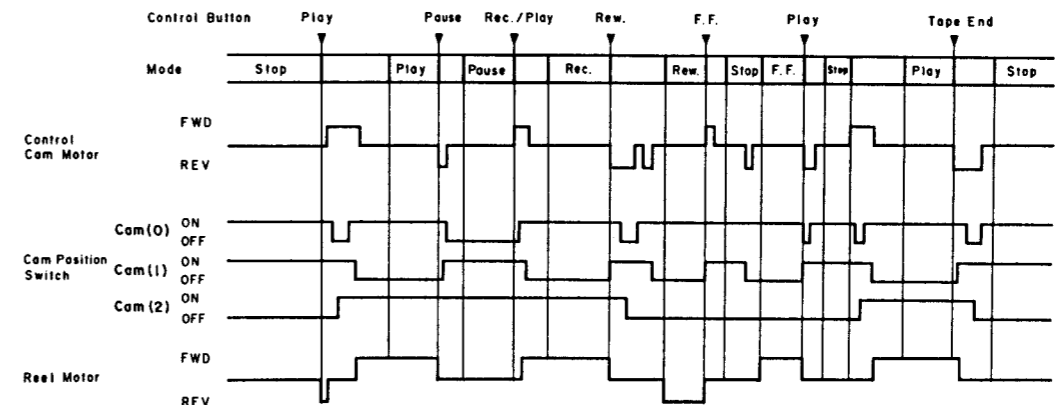

Fig. 12.1.2

12.2. Eq. Amp. Frequency Response

(1) For Serial No.: A13102451 - (CR-4A)/A13153801 - (CR-4/4E/40)
 (a) Playback Frequency Response

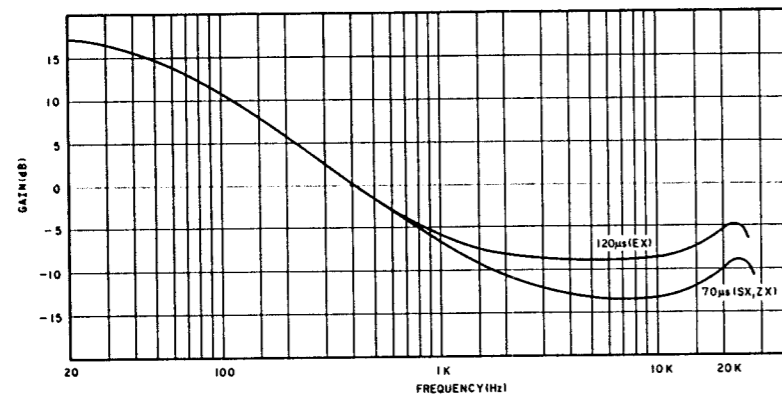

Fig. 12.2.1.1 Serial No.: A13102451 - (CR-4A)
 A13153801 - (CR-4/4E/40)

(b) Record Current Frequency Response

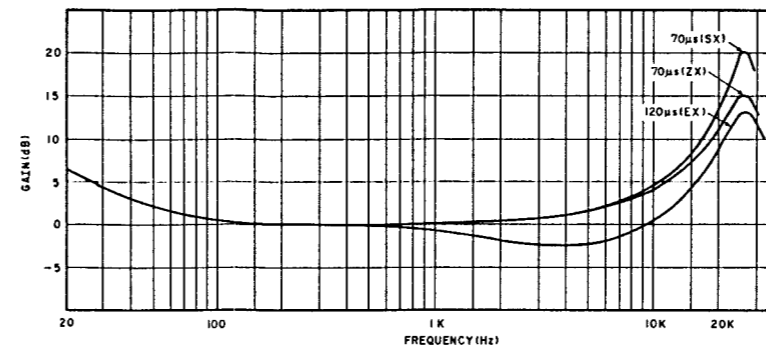

Fig. 12.2.1.2 Serial No.: A13102451 - (CR-4A)
 A13153801 - (CR-4/4E/40)

(2) For Serial Nos.: A13101001 - 02450 (CR-4A)/A13150001 - 53800 (CR-4/4E/40)
 (a) Playback Frequency Response

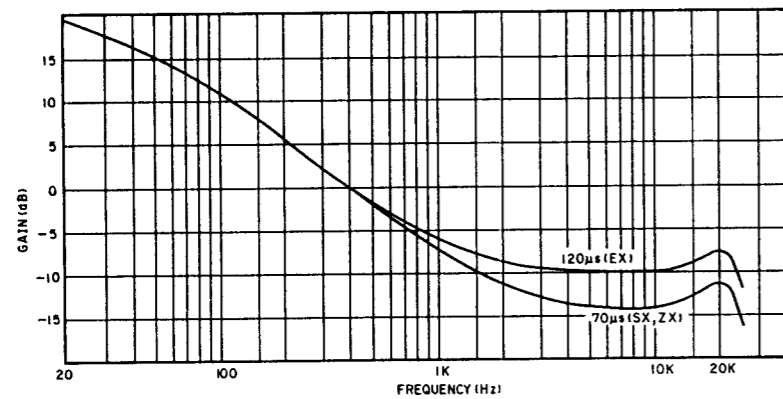

Fig. 12.2.2.1 Serial Nos.: A13101001 - 02450 (CR-4A)
 A13150001 - 53800 (CR-4/4E/40)

(b) Record Current Frequency Response

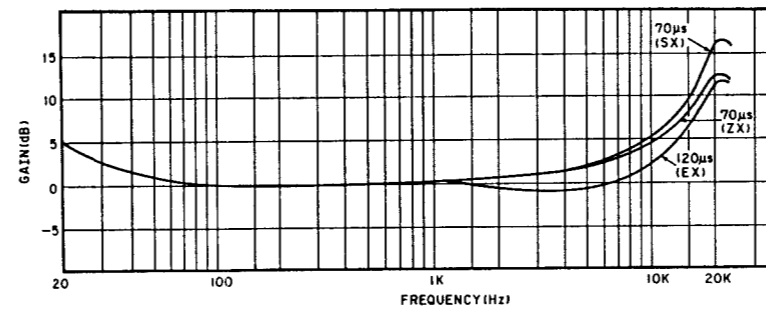

Fig. 12.2.2.2 Serial Nos.: A13101001 - 02450 (CR-4A)
 A13150001 - 53800 (CR-4/4E/40)

13. SPECIFICATIONS

Track Configuration	4 tracks/2-channel stereo
Heads	3 (erase head x 1, record head x 1, playback head x 1)
Motors	<Tape Transport> FG servo brushless, slotless, coreless DD motor (capstan drive) x 1 DC motor (reel drive) x 1 <Mechanism> DC motor (cam drive) x 1
Power Source	120, 220, 240 or 110/127/220/240 V AC, 50/60 Hz (According to country of sale)
Power Consumption	38 W max.
Tape Speed	1-7/8 ips (4.8 cm/sec.) ±0.5%
Wow and Flutter	Less than ±0.048% WTD Peak Less than 0.027% WTD RMS
Frequency Response	20 Hz—21,000 Hz ±3 dB (recording level -20 dB, ZX [Type IV], SX [Type II], EXII [Type I] tape)
Signal to Noise Ratio	Dolby C-Type NR on <70 μs, ZX [Type IV] tape> Better than 72 dB (400 Hz, 3% THD, IHF A-WTD RMS) Dolby B-Type NR on <70 μs, ZX [Type IV] tape> Better than 66 dB (400 Hz, 3% THD, IHF A-WTD RMS)
Total Harmonic Distortion	Less than 0.8% (400 Hz, 0 dB, ZX [Type IV] tape) Less than 1.0% (400 Hz, 0 dB, SX [Type II], EXII [Type I] tape)
Erasure	Better than 60 dB (100 Hz, +10 dB)
Separation	Better than 37 dB (1 kHz, 0 dB)
Crosstalk	Better than 60 dB (1 kHz, 0 dB)
Bias Frequency	105 kHz
Input (Line)	50 mV/30k ohms
Output (Line)	0.5 V (400 Hz, 0 dB, output level control at max.) 2.2k ohms
(Headphones)	5 mW into 8 ohms (400 Hz, 0 dB, output level control at max.)
Fast-Wind Time	Approx. 80 seconds (with C-60 cassette)
Dimensions	430 (W) x 100 (H) x 265 (D) mm 16-15/16 (W) x 3-15/16 (H) x 10-7/16 (D) inches
Approximate Weight	5.9 kg, 13 lbs.

- Specifications and design are subject to change for further improvement without notice.
- Noise Reduction System manufactured under license from Dolby Laboratories Licensing Corporation.
- The word "DOLBY" and the Double-D-Symbol are trademarks of Dolby Laboratories Licensing Corporation.

Service Manual

Nakamichi

CR-4, CR-4A, CR-4E, CR-40

Nakamichi Corporation/Tokyo Office
Nakamichi America Corporation
Nakamichi Canada
Nakamichi GmbH
Nakamichi Australia

Shinjuku Daiichi Seimei Bldg., 2-7-1 Nishishinjuku, Shinjuku-ku, Tokyo 163 Phone: (03) 342-4461 Telex: 2337 21 (NAKAM J)
19701 South Vermont Ave., Torrance, CA 90502 Phone: (213) 538-8150
276 South West, Marine Drive, Vancouver, B.C. V5X 2R4 Phone: (604) 324-7535
Stephanienstrasse 6, 4000 Düsseldorf 1 Phone: (0211) 359036
Unit 10, 21-29 Chester Street, Camperdown, N.S.W. 2050 Phone: (02) 519-3977