



Service Manual

Nakamichi

CR-7

CR-7A

CR-7E

Discrete Head Cassette Deck

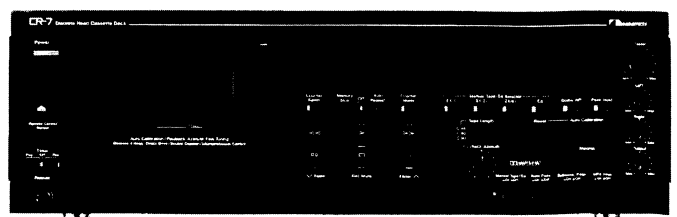

CONTENTS

1.	General	2
2.	Test Tapes and Gauges	2
3.	Mechanical Adjustments	2
3. 1.	Record Head and Playback Head Tilt Adjustment	2
3. 2.	Head Base Stroke Check	3
3. 3.	Erase Head Stroke Adjustment and Tape Guide Height Check	3
3. 4.	Erase Head Height and Tilt Adjustment	3
3. 5.	Playback Head Azimuth Center Adjustment	4
3. 6.	Playback Head and Record Head Height Adjustment and Azimuth Alignment	4
3. 7.	Tape Travelling Check	4
3. 8.	Eject Damper Adjustment	4
3. 9.	Reel Motor Speed Adjustment in Play Mode	4
3. 10.	Tape Speed Adjustment	5
3. 11.	Lubrication	5
4.	Parts Location for Electrical Adjustment	6
5.	Electrical Adjustments	7
5. 1.	How to Use Measurement Tools	7
5. 2.	Adjustment Instructions	8
5. 3.	Playback Frequency Response Adjustment	14
6.	Mechanism Ass'y and Parts List	15
6. 1.	Synthesis	15
6. 2.	Chassis Ass'y (A01)	16
6. 3.	Front Escutcheon L Ass'y (B01)	16
6. 4.	Front Escutcheon R Ass'y (B02)	17
6. 5.	Mechanism Ass'y (B03)	18
6. 6.	Rear Panel Ass'y (B04)	19
6. 7.	Front Escutcheon R Sub Ass'y (C01)	19
6. 8.	D.D. Motor Ass'y (D01)	19
7.	Mounting Diagrams and Parts List	20
7. 1.	Power Switch P.C.B. Ass'y	20
7. 2.	Shut-off P.C.B. Ass'y	20
7. 3.	Azimuth Motor P.C.B. Ass'y	20
7. 4.	Timer Switch P.C.B. Ass'y	20
7. 5.	Headphone Jack P.C.B. Ass'y	20
7. 6.	Azimuth Control P.C.B. Ass'y	20
7. 7.	Pin Jack P.C.B. Ass'y	21
7. 8.	Volume P.C.B. Ass'y	21
7. 9.	Receiver P.C.B. Ass'y	21
7. 10.	Remote Control P.C.B. Ass'y	21
7. 11.	Control Switch P.C.B. Ass'y	22
7. 12.	Display P.C.B. Ass'y	23
7. 13.	Dolby NR P.C.B. Ass'y	25
7. 14.	Power Supply P.C.B. Ass'y	27
7. 15.	Main P.C.B. Ass'y	29
7. 16.	Logic P.C.B. Ass'y	34
8.	Schematic Diagrams	35
8. 1.	IC Block Diagrams	35
8. 2.	Schematic Diagrams	37
8.2.1.	Display Section	37
8.2.2.	Amplifier Section	38
8.2.3.	Mechanism Control Section	40
9.	Wiring Diagram	41
10.	Block Diagrams	42
10. 1.	Amplifier Section	42
10. 2.	Mechanism Control Section	43
11.	Timing Chart and Eq. Amp. Frequency Response	44
11. 1.	Eq. Amp. Frequency Response	44
11. 2.	Timing Chart	44
12.	Remote Control Unit RM-7C	45
13.	Specifications	46

1. GENERAL

1.1. Voltage Selector

Voltage selector is installed on the rear panel for Other version of the Nakamichi CR-7. This voltage selector can select either 120 V or 220-240 V at customer's disposal.

1.2. Packing Materials and Owner's Manuals

Part No.	Description	Q'ty
0F03900A	Packing	2
0F03928A	Carton Box CR-7A	1
0F03922A	Carton Box CR-7E	1
0F03926A	Carton Box CR-70	1
0F03921A	Carton Box CR-7	1
0M03884A	Voltage Label 120V (Canada)	2
0M03457A	Voltage Label 240V (Australia & UK)	2
0D04561B	Owner's Manual CR-7E/CR-5E, CR-7/CR-5 (English/German/French)	1
0D04562B	Owner's Manual CR-70/CR-50 (Japanese)	1
0D04563C	Owner's Manual CR-7A/CR-5A, CR-7/CR-5 (English)	1
HA04956A	Remote Control Unit RM-7C	1

2. TEST TAPES AND GAUGES

- | | |
|--|----------------------------------|
| (1) 400 Hz Level Tape (DA09005B) | (15) Tilt Check Gauge (DA09039B) |
| (2) 1 kHz Track Alignment Tape (DA09007B) | (16) Torque Gauge FWD (DA09082A) |
| (3) 10 kHz PB Frequency Response Tape (DA09003B) | (17) Test Unit (DA09101A) |
| (4) 15 kHz PB Frequency Response Tape (DA09002B) | |
| (5) 20 kHz PB Frequency Response Tape (DA09001B) | |
| (6) 15 kHz Azimuth Alignment Tape (DA09004B) | |
| (7) 3 kHz Speed and Wow/Flutter Tape (DA09006C) | |
| (8) Tape Travelling Cassette Tape (DA09071A) | |
| (9) Reference EXII Tape (DA09102A) | |
| (10) Reference SX Tape (DA09103A) | |
| (11) Reference ZX Tape (DA09100A) | |
| (12) EH Tilt Check Gauge S (DA09088A) | |
| (13) Stroke Check Gauge S (DA09090A) | |
| (14) Tape Guide Height Check Gauge S (DA09091A) | |

3. MECHANICAL ADJUSTMENTS

3.1. Record Head and Playback Head Tilt Adjustment

Remove the Cover Plate Ass'y by loosening two screws. Refer to Fig. 3.1.

- (1) Remove the pad lifter from the playback head.
- (2) Load a Tilt Check Gauge in the cassette deck.
- (3) Remove both of the Height Gears (PH and RH).
- (4) Set the cassette deck in Play mode. Check to insure whether the Beacons Playback Head "Upper" or "Lower" and Record Head "Upper" or "Lower" are illuminating. In order not to give damages onto the head surfaces, push both of slide knobs of the Gauge away from the heads, then return them to their original places to be in contact with the record head and the playback head surfaces after Play mode is securely locked.
- (5) The beacon playback Head "Lower" will light up when the height adjustment screw (PH) is turned counterclockwise but the Playback Head "Upper" when clockwise. Adjust so that both "Upper" and "Lower" will light up even when you move the slide knob away from the head and then return it to the original place.
- (6) The same procedures will apply to the Beacons Record Head "Upper" and "Lower", except for the height adjustment screw (RH).

- (7) Set the cassette deck in Stop mode and fit both of the serrated Height Gears. Then set the cassette deck in Play mode again and insure all of the 4 Beacons are illuminating. If not, (5) and (6) will have to be repeated till satisfactory results are obtained.
- (8) Mount the pad lifter on the playback head.

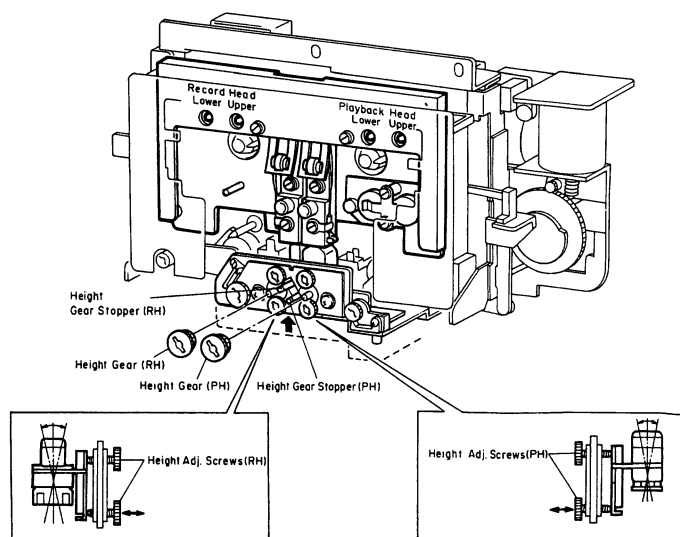

Fig. 3.1

3.2. Head Base Stroke Check

Remove the Cover Plate Ass'y. Refer to Fig. 3.2.

Note: Before you conduct this adjustment, adjust with a "Tilt Check Gauge" to insure freedom from tilt on the playback head and record head.

- (1) Load a Stroke Check Gauge S in the cassette deck.
- (2) Move the Record Head Indicator and the Playback Head Indicator to the direction of arrow mark "A" with your finger tip and then set the cassette deck in Play mode. Then slowly release the Indicators and make sure that each of the Indicators is in contact with the record and the playback heads.
- (3) Check to insure whether the line "P" on the Playback Head Indicator meets the central line on the Indicator Plate.
- (4) Check to insure whether the line "P" on the Playback Head Indicator locates between the 2 lines on the Record Head Indicator, thus check can be made on record head stroke.

3.3. Erase Head Stroke Adjustment and Tape Guide Height Check

Remove the Head Mount Base Ass'y and the Cover Plate Ass'y. Refer to Fig. 3.3.

(1) Erase Head Stroke Adjustment

- (a) Load a Tape Guide Height Check Gauge S in the cassette deck.
- (b) Set the cassette deck in Play mode, thus check can be made on erase head stroke through the EH Stroke Indicator.
- (c) Check to insure whether the erase head surface is aligned with red line on the EH Stroke Indicator. If not, adjust the erase head stroke by loosening screw A that assembles the erase head with erase head plate.
- (d) After completion of the adjustment, screw A shall be locked with lock tight paint.

(2) Supply Tape Guide Height Check

- (a) Load a Tape Guide Height Check Gauge S in the cassette deck.
- (b) Set the cassette deck in Play mode.
- (c) Slide the Supply Tape Guide Check Bar down onto the supply tape guide, and check to insure that the Supply Tape Guide Check Bar is accepted by the supply tape guide.

(3) Take-up Tape Guide Height Check

- (a) Load a Tape Guide Height Check Gauge S in the cassette deck.
- (b) Set the cassette deck in Play mode.
- (c) Slide the Take-up Tape Guide Check Bar down onto the take-up tape guide, and check to insure that the Take-up Tape Guide Check Bar is accepted by the take-up tape guide.

3.4. Erase Head Height and Tilt Adjustment

Refer to Fig. 3.4.

- (1) Remove the Cassette Case Ass'y, Head Mount Base Ass'y and Cover Plate Ass'y.
- (2) Load an EH Tilt Check Gauge S in the cassette deck.
- (3) Set the cassette deck in Stop mode.
- (4) Check to insure whether one of the 3 Beacons is illuminating. Look down the mirror and slowly turn the Screw "Height" counterclockwise (or clockwise) so that the line of the erase head (in different color) is located between the two horizontal lines on the mirror and check to insure whether the first Beacon is illuminating.
- (5) Turn the Screw "Tilt" counterclockwise (or clockwise) to light up the second Beacon. Excessive turning will cause the first Beacon to light off.

Adjustment of the Screw "Tilt" will therefore be conducted till both of the first and the second Beacons illuminate.

- (6) Turn Screw "Azimuth" counterclockwise (or clockwise) to light up the third Beacon. Excessive turning will cause either the first or the second Beacon to light off, and therefore adjust Screw "Azimuth" until all of the 3 Beacons illuminate.
- (7) Check to insure whether the horizontal line of the erase head is located between two lines on the mirror. If not, (4) through (6) must be repeated till satisfactory results are obtained.
- (8) After completion of adjustment, 3 pcs. of screws shall be locked with lock tight paint.

Note: Before use of this gauge, check to insure freedom from dust or dirt, or overflow in the groove of the erase head surface.

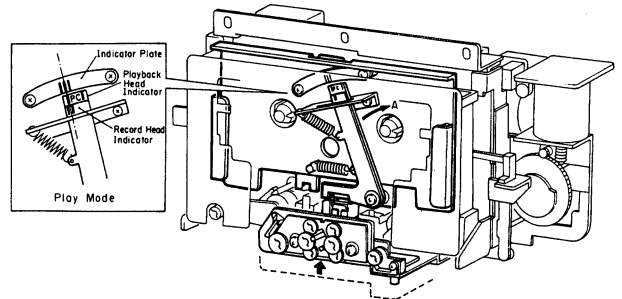

Fig. 3.2

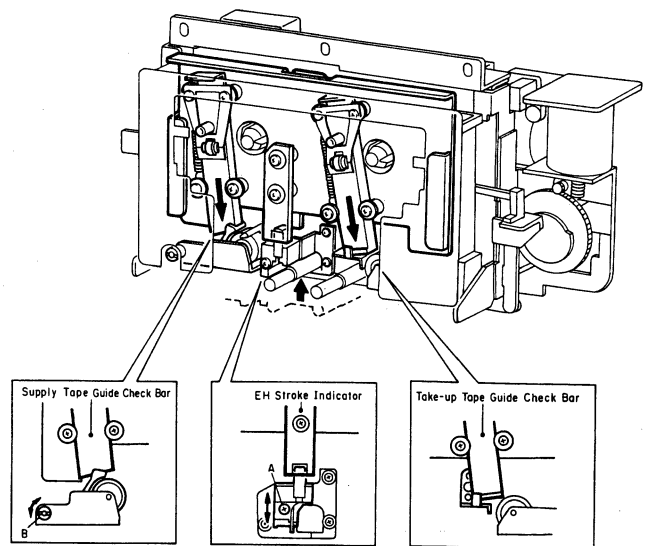

Fig. 3.3

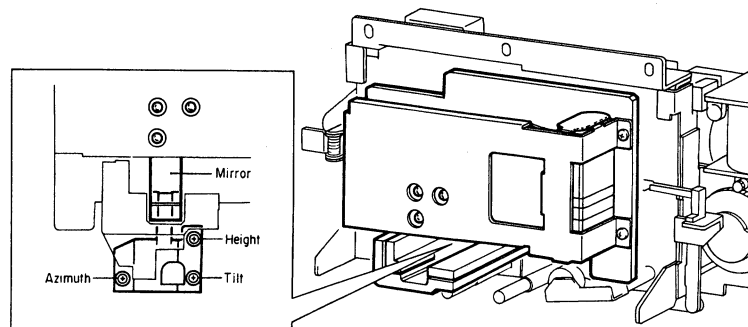

Fig. 3.4

3.5. Playback Head Azimuth Center Adjustment

Note: Refer to item 5.1.2 "Test Unit" for handling the Test Unit.

- (1) Remove the Top Cover by loosening four screws and the Front Panel by loosening six screws.
- (2) Separate the Front Escutcheon R Ass'y from the Front Chassis by loosening four screws and slide it to the right to gain access to the Azimuth Center potentiometer.
- (3) Connect the Test Unit to CN-11 on the Logic P.C.B. Ass'y.
- (4) Turn ON the power and press the TEST button on the Test Unit.
- (5) Press the CENTER button on the Test Unit.
- (6) Adjust the Azimuth Center potentiometer so that the arrow mark on the Azimuth Cam Gear corresponds to the Indicator Plate of the Mechanism Chassis as shown in Fig. 3.5.
- (7) Press the TEST button twice.
- (8) Turn OFF the power, remove the Test Unit from CN-11 and assemble the Front Escutcheon R Ass'y, Front Panel and Top Cover.

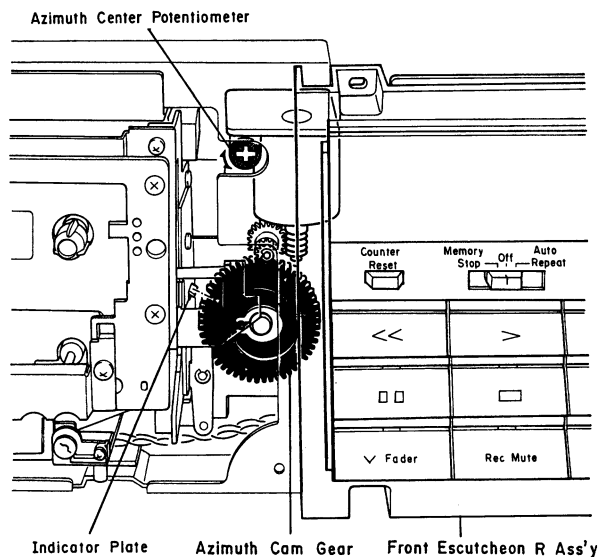

Fig. 3.5

3.6. Playback Head and Record Head Height Adjustment and Azimuth Alignment

Remove the Top Cover by loosening four screws. Refer to Fig. 3.6.

(1) Playback Head Height Adjustment and Azimuth Alignment

Note: Refer to item 5.1.2 "Test Unit" for handling the Test Unit.

- (a) Connect the Test Unit to CN-11 on the Logic P.C.B. Ass'y.
- (b) Press the MONITOR button to select the Tape position and connect an AC voltmeter to the Output Jacks.
- (c) Press the TEST button on the Test Unit.
- (d) Press the CENTER button on the Test Unit.
- (e) Load a 1 kHz Track Alignment Tape and play it back.
- (f) Turn the PH Height Gear until the outputs of both channels become minimum.
- (g) Load a 15 kHz Azimuth Tape and play it back.
- (h) Turn the PH Azimuth Alignment Screw until the outputs of both channels become maximum.
- (i) Repeat above steps (e) through (h) one or two times to obtain optimum performance.
- (j) Press the TEST button twice, then remove the Test Unit from CN-11.

(2) Record Head Height Adjustment and Azimuth Alignment

(a) Connect the Test Unit to CN-11 on the Logic P.C.B. Ass'y.

- (b) Press the TEST button on the Test Unit.
- (c) Press the CENTER button on the Test Unit.
- (d) Press the MONITOR button to select the Tape position and set the Eq. to 70 μ s.
- (e) Load a reference ZX tape and connect an AC voltmeter to the Output Jacks.
- (f) Feed in 400 Hz (0 dBV) to the Input Jacks.
- (g) Set the cassette deck in Rec./Play mode and turn the RH Height Gear until the outputs of both channels become maximum.

- (h) Feed in 15 kHz (-20 dBV) to the Input Jacks and turn the RH Azimuth Alignment Screw until the outputs of both channels become maximum.
- (i) Repeat (f) through (h) one or two times to obtain optimum performance.
- (j) Press the TEST button twice, then remove the Test Unit from CN-11.

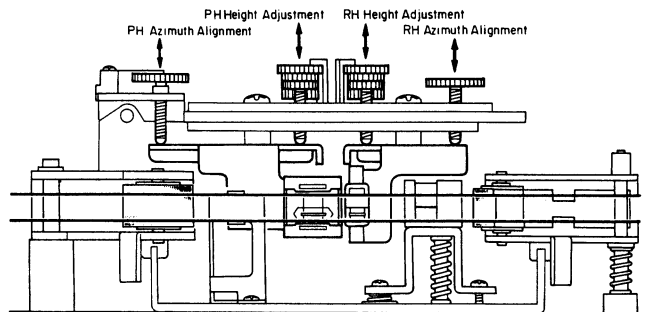

Fig. 3.6

3.7. Tape Travelling Check

Load and play back a Tape Travelling Cassette and check the followings:

- (1) Tape is in contact with heads sufficiently.
- (2) Tape waviness is small on the heads and pressure rollers.
- (3) Tape is free from waviness or slippage from the tape guide.

3.8. Eject Damper Adjustment

Refer to Fig. 3.7. Load a cassette tape and with opening and closing the Cassette Case, adjust the speed of damper action by the Damper Adjustment Screw.

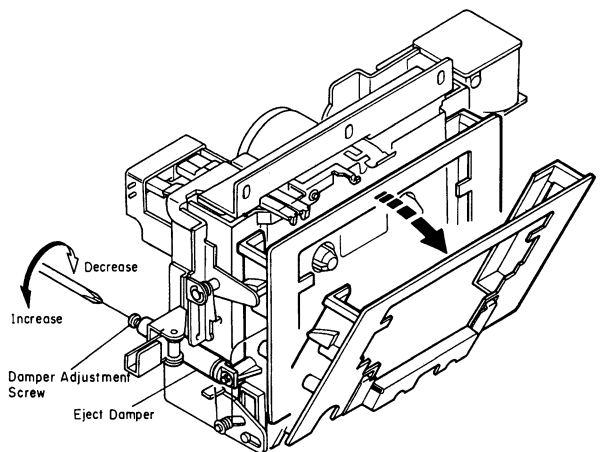

Fig. 3.7

3.9. Reel Motor Speed Adjustment in Play Mode

- (1) In order to warm-up the cassette deck, load a C-60 cassette tape and play it back for more than four minutes.
- (2) Load a Torque Gauge FWD or equivalent and set the cassette deck in Play mode.
- (3) Adjust VR601 on the Logic P.C.B. Ass'y to obtain exactly 50 g-cm on the torque gauge.

3.10. Tape Speed Adjustment

Refer to Fig. 3.8.

- (1) Connect a frequency counter to the Output Jack.
- (2) Load a 3 kHz Speed and Wow/Flutter Tape and play it back.
- (3) Adjust VR101 on the Motor P.C.B. Ass'y to obtain 3,000 Hz \pm 15 Hz on the frequency counter.

3.11. Lubrication

The tape transport mechanism is of a lubrication-free type. However, when the following parts are replaced with new ones, apply the specified lubricant.

- (1) Molykote (R) Grease (X5-6020)
Cam Motor Pulley
Thrust portion on the Capstan Shaft
- (2) FLOIL GB-TS-1
Washer between Reel Hub Ass'y and Back Tension Spring
- (3) Diamond Oil (EP56)
Reel Hub Shaft
- (4) Anderol 456
Capstan Shaft

Note: We suggest that you use the above specified lubricant or equivalent type.

The company dealing in the above lubricant is as follows:

- (a) Molykote (R) Grease (X5-6020)
Dowcorning Co., Ltd., 1-15-1 Nishishinbashi, Minato-ku, Tokyo, Japan
- (b) FLOIL GB-TS-1
Kanto Chemicals Co., Ltd., 2-7 Kanda Sakumacho, Chiyoda-ku, Tokyo, Japan
- (c) Diamond Oil (EP-56)
Mitsubishi Oil Co., Ltd., 1-2-4 Toranomom, Minato-ku, Tokyo, Japan
- (d) Anderol 456
Tokyo Kokusai Oil Co., Ltd., 3-3-5 Hatchobori, Chuo-ku, Tokyo, Japan

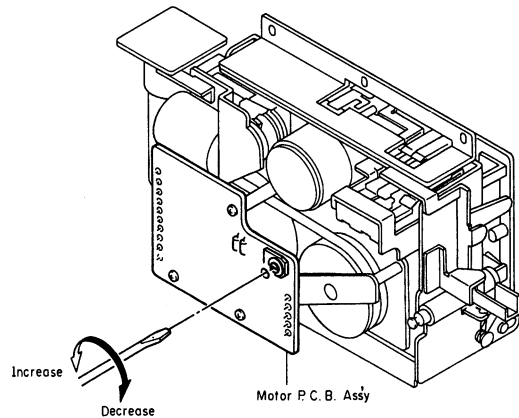

Fig. 3.8

4. PARTS LOCATION FOR ELECTRICAL ADJUSTMENT

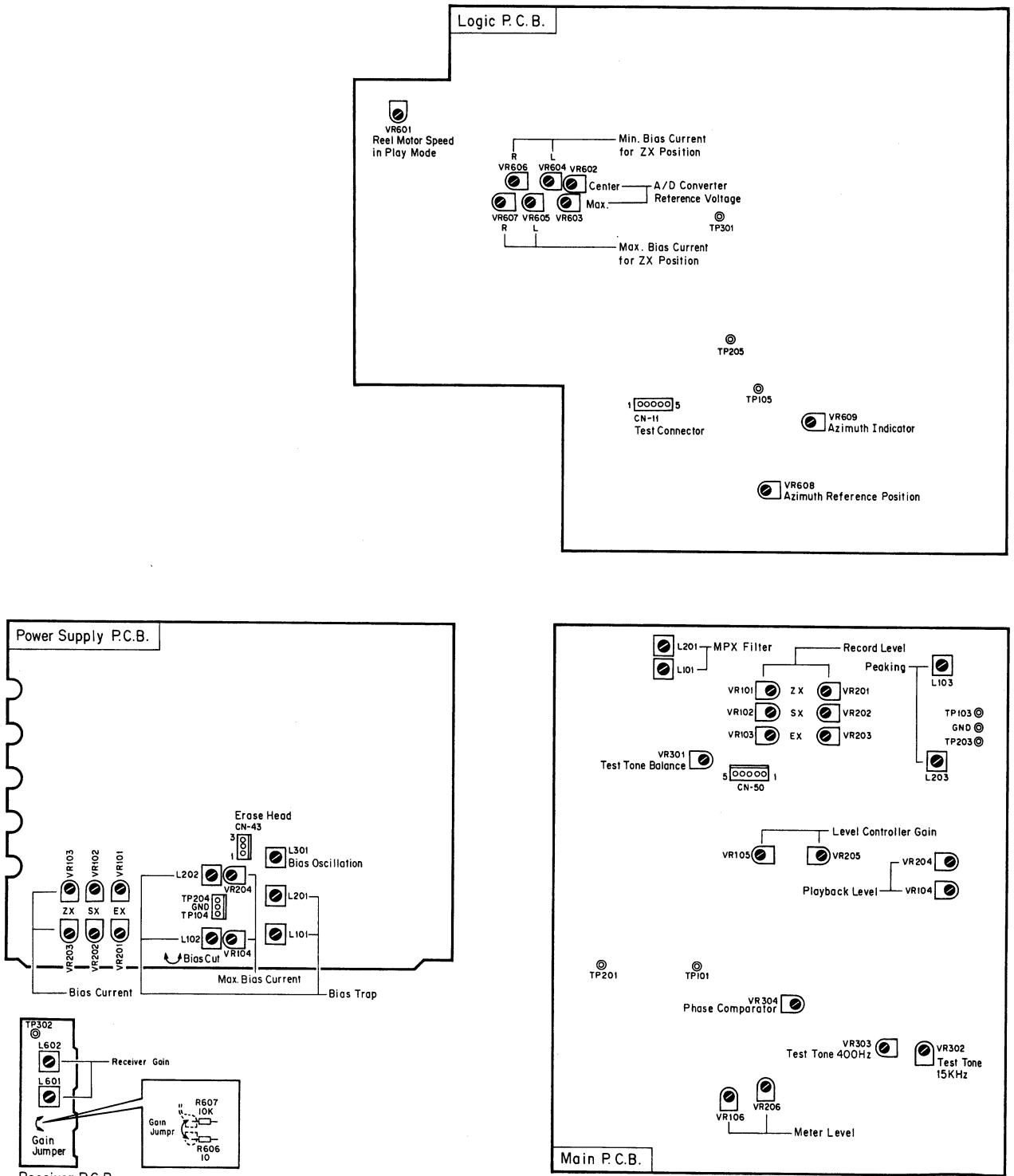

Fig. 4

5.2. Adjustment Instructions

STEP	ITEM	SIGNAL SOURCE	OUTPUT CONNECTION	MODE	ADJUSTMENT	REMARKS
1	Tape Speed Adjustment	3 kHz Speed and Wow/Flutter Tape	Frequency Counter to Output Jacks	Play Eq. - 70 μ s	Motor P.C.B. VR101	Adjust VR101 to obtain 3 kHz \pm 15 Hz on the frequency counter.
2	Meter Level Calibration	400 Hz to Input Jacks	AC Voltmeter to TP101, TP201 on Main P.C.B.	Monitor - Source	Main P.C.B. VR106 VR206	<ol style="list-style-type: none"> Adjust the Input Level controls to obtain 350 mV -0.6 dB on the AC voltmeter. Adjust VR106 (VR206) so that the 0 dB segment of the level meter begins to light up.
3	MPX Filter Adjustment	19 kHz to Input Jacks	AC Voltmeter to Output Jacks	Monitor - Source MPX - ON	Main P.C.B. L101 L201	<ol style="list-style-type: none"> Set the Output Level control to max. Feed in 19 kHz (0 dBV) to the Input Jacks. Adjust L101 (L201) to obtain minimum reading on the AC voltmeter. (The minimum reading will be less than -30 dBV.)
4	Bias Oscillation Frequency and Erase Current Adjustment		Frequency Counter to TP103 on Main P.C.B. and AC Voltmeter to Bias Osc. Coil (See Fig. 5.1.)	Rec./Pause Tape - SX	Power Supply P.C.B. L301 R302 R303	<ol style="list-style-type: none"> Connect a 0.1-ohm resistor and a Bias Osc. coil (OB06646B) to the Erase Head and an AC voltmeter to the 36-turn winding of the Bias Osc. coil as shown in Fig. 5.1. Adjust L301 to obtain 105 kHz on the frequency counter. Check the erase current by the AC voltmeter. Erase current will be within the range of 310 mA to 400 mA (20.3 mV to 26.2 mV on the AC voltmeter). (Typically approx. 350 mA or 23 mV on the AC voltmeter.) If erase current is not sufficient, increase it by shorting either R302 or R303. Erase current is given in the following formula. $I_e = \frac{V_e \times 55(\text{turns})}{36(\text{turns}) \times 0.1}$ After completion of the erase current adjustment, re-check the bias oscillation frequency. Remove the Bias Osc. Coil and the 0.1-ohm resistor.
5	Bias Trap Adjustment		AC Voltmeter to TP103, TP203 on Main P.C.B. TP104, TP204 on Power Supply P.C.B.	Rec./Pause Tape - ZX	Power Supply P.C.B. L101 L201 L102 L202	<ol style="list-style-type: none"> Connect an AC voltmeter to TP103 (TP203). Adjust L102 (L202) to obtain minimum reading on the AC voltmeter. Connect the AC voltmeter to TP104 (TP204). Adjust L101 (L201) to obtain maximum reading on the AC voltmeter.

STEP	ITEM	SIGNAL SOURCE	OUTPUT CONNECTION	MODE	ADJUSTMENT	REMARKS
6	Recording Bias Current Adjustment		AC Voltmeter to TP104, TP204 on Power Supply P.C.B.	Rec./Pause Tape - ZX/SX/EX	Power Supply P.C.B. EX: VR101 VR201 SX: VR102 VR202 ZX: VR103 VR203 Max: VR104 VR204 Logic P.C.B. ZX min: VR604 VR606 ZX max: VR605 VR607	<ol style="list-style-type: none"> 1. Load a reference ZX tape and set the cassette deck in Rec./Pause mode. 2. Set the Tape selector to the ZX position. 3. Connect an AC voltmeter to TP104 (TP204). 4. Turn VR103 (VR203) fully clockwise. 5. Connect the Test Unit to CN-11 on the Logic P.C.B. Ass'y. 6. Press the TEST button on the Test Unit. 7. Press the MAX button on the Test Unit. 8. Adjust VR104 (VR204) to obtain 80 mV on the AC voltmeter. (The maximum bias current is set to 8 mA.) 9. Return VR103 (VR203) to its mechanical center position. 10. Adjust VR605 (VR607) to obtain 70 mV on the AC voltmeter. (The maximum bias current for the ZX position is set to 7 mA.) 11. Press the TEST button. 12. Press the MIN button on the Test Unit. 13. Adjust VR604 (VR606) to obtain 25 mV on the AC voltmeter. (The minimum bias current for the ZX position is set to 2.5 mA.) 14. Repeat above 6 through 13 one or two times. 15. Press the TEST button. 16. Press the CENTER button. 17. Change the cassette tape to a reference SX tape and set the Tape selector to the SX position. 18. Adjust VR102 (VR202) to obtain 20 mV on the AC voltmeter. (The middle value of bias current for the SX position is set to 2 mA.) 19. Change the cassette tape to a reference EXII tape and set the Tape selector to the EX position. 20. Adjust VR101 (VR201) to obtain 13 mV on the AC voltmeter. (The middle value of bias current for the EX position is set to 1.3 mA.) 21. Press the TEST button twice, then remove the Test Unit from CN-11.
7	A/D Converter Reference Voltage Adjustment		DC Voltmeter to TP301 on Logic P.C.B.	Rec./Pause	Logic P.C.B. VR602 VR603	<ol style="list-style-type: none"> 1. Connect the Test Unit to CN-11 on the Logic P.C.B. Ass'y. 2. Press the TEST button on the Test Unit. 3. Press the MAX button on the Test Unit. 4. Adjust VR603 to obtain 2.00 V on the DC voltmeter. 5. Press the TEST button. 6. Press the CENTER button on the Test Unit. 7. Adjust VR602 to obtain 1.00 V on the DC voltmeter. 8. Repeat above 2 through 7 one or two times. 9. Press the TEST button twice, then remove the Test Unit from CN-11.

STEP	ITEM	SIGNAL SOURCE	OUTPUT CONNECTION	MODE	ADJUSTMENT	REMARKS
8	Test Tone Level Adjustment		DC Voltmeter to TP105, TP205 on Logic P.C.B.	Rec./Pause Monitor - Source	Main P.C.B. Bal: VR301 15 kHz: VR302 400 Hz: VR303	<ol style="list-style-type: none"> 1. Connect a DC voltmeter to TP105. 2. Connect the Test Unit to CN-11 on the Logic P.C.B. Ass'y. 3. Press the TEST button on the Test Unit. 4. Press the OSC button on the Test Unit. 5. Press the Auto Calibration button of the cassette deck. The Level indicator will light up. 6. Adjust VR303 to obtain 1.00 V on the DC voltmeter. 7. Press the Auto Calibration button again. The Bias indicator will light up. 8. Adjust VR302 to obtain 0.93-0.94 V on the DC voltmeter. 9. Repeat above 4 through 8 one or two times. 10. Remove the DC voltmeter from TP105 and connect it to TP205. 11. Press the Auto Calibration button. The Level indicator will light up. 12. Adjust VR301 to obtain 1.00 V on the DC voltmeter. 13. Press the TEST button twice, then remove the Test Unit from CN-11.
9	Level Controller Gain Adjustment	400 Hz (0 dBV) to Input Jacks	AC Voltmeter to CN50-2, CN50-4, CN50-1, and CN50-5 on Main P.C.B.	Rec./Pause Monitor - Source	Main P.C.B. VR105 VR205	<ol style="list-style-type: none"> 1. Connect an AC voltmeter between pin 4 (pin 5) and Ground. 2. Feed in 400 Hz (0 dBV) to the Input Jacks. 3. Connect the Test Unit to CN-11 on the Logic P.C.B. Ass'y. 4. Set the Monitor selector to the Source position. 5. Press the TEST button on the Test Unit. 6. Press the CENTER button on the Test Unit. 7. Note the reading at pin 4 (pin 5) on the AC voltmeter. 8. Connect the AC voltmeter to pin 2 (pin 1), then adjust VR105 (VR205) to obtain the same level at pin 4 (pin 5) on the AC voltmeter. 9. Press the TEST button twice, then remove the Test Unit from CN-11.
10	Playback Head Azimuth Center Adjustment			Stop	Azimuth Motor P.C.B. Azimuth Center Potentiometer	<p>Refer to item 3.5.</p> <ol style="list-style-type: none"> 1. Connect the Test Unit to CN-11 on the Logic P.C.B. Ass'y. 2. Press the TEST button on the Test Unit. 3. Press the CENTER button on the Test Unit. 4. Adjust the potentiometer so that the arrow mark of the Cam corresponds to the Indicator Plate of the Mechanism Chassis as shown in Fig. 3.5.

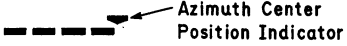
STEP	ITEM	SIGNAL SOURCE	OUTPUT CONNECTION	MODE	ADJUSTMENT	REMARKS
11	Azimuth Reference Position Adjustment			Play	Logic P.C.B. VR608	<ol style="list-style-type: none"> 1. Connect the Test Unit to CN-11 on the Logic P.C.B. Ass'y. 2. Turn the Playback Azimuth control to its mechanical center position. 3. Press the TEST button on the Test Unit. 4. Press the AZ button on the Test Unit. 5. Adjust VR608 so that the Ready indicator lights up. 6. Press the TEST button twice, then remove the Test Unit from CN-11.
12	Azimuth Indicator Adjustment			Play	Logic P.C.B. VR609	<ol style="list-style-type: none"> 1. Connect the Test Unit to CN-11 on the Logic P.C.B. Ass'y. 2. Press the TEST button on the Test Unit. 3. Press the CENTER button on the Test Unit. 4. Adjust VR609 so that the indicator segments of upper row indicate the Azimuth Center Position indicator as shown below: <div style="text-align: center; margin: 10px 0;">  <p style="margin: 0;">Azimuth Center Position Indicator</p> </div> 5. Press the TEST button. 6. Press the MAX button on the Test Unit. 7. Check whether all indicator segments of upper row light up. If not, repeat above 2 through 7. 8. Press the TEST button twice, then remove the Test Unit.
13	Playback Head Track Alignment and Azimuth Alignment	1 kHz Track Alignment Tape and 15 kHz Azimuth Tape	AC Voltmeter to Output Jacks	Play Monitor - Tape Eq. - 70 μs	PH Height Gear and Playback Head Azimuth Alignment Screw	<ol style="list-style-type: none"> 1. Connect the Test Unit to CN-11 on the Logic P.C.B. Ass'y. 2. Press the TEST button on the Test Unit. 3. Press the CENTER button on the Test Unit. 4. Set the Output control to max. 5. Load a 1 kHz Track Alignment Tape and play it back. 6. Adjust the PH Height Gear to obtain minimum readings for both channels on the AC voltmeter. 7. Load a 15 kHz Azimuth Tape and play it back. 8. Adjust the Playback Head Azimuth Alignment Screw to obtain maximum readings for both channels on the AC voltmeter. 9. Repeat above 4 through 8 once or twice. 10. Press the TEST button twice, then remove the Test Unit from CN-11.

STEP	ITEM	SIGNAL SOURCE	OUTPUT CONNECTION	MODE	ADJUSTMENT	REMARKS
14	Playback Level Calibration	400 Hz Level Tape	AC Voltmeter to TP101, TP201 on Main P.C.B.	Play Monitor - Tape Eq. - 70 μ s	Main P.C.B. VR104 VR204	<ol style="list-style-type: none"> 1. Connect the Test Unit to CN-11 on the Logic P.C.B. Ass'y. 2. Press the TEST button on the Test Unit. 3. Press the CENTER button on the Test Unit. 4. Load a 400 Hz level tape and play it back. 5. Adjust VR104 (VR204) to obtain 350 mV on the AC voltmeter. 6. Press the TEST button twice, then remove the Test Unit from CN-11.
15	Playback Frequency Response Adjustment	400 Hz Level Tape 10 kHz PB Frequency Response Tape 15 kHz PB Frequency Response Tape 20 kHz PB Frequency Response Tape	AC Voltmeter to Output Jacks	Same as above	Main P.C.B. R143 R243 R144 R244	<ol style="list-style-type: none"> 1. Connect the Test Unit to CN-11 on the Logic P.C.B. Ass'y. 2. Press the TEST button on the Test Unit. 3. Press the CENTER button on the Test Unit. 4. Load a 400 Hz level tape and play it back. Adjust the Output Level control to obtain 0 dBV (1 V) on the AC voltmeter. 5. Load 10 kHz, 15 kHz and 20 kHz PB frequency response tapes and play them back in order. Align the playback head azimuth to obtain maximum levels on the AC voltmeter with each tape and note their levels. 6. Check whether the maximum levels are within the ranges given below. If not, short R143 (R243) or R144 (R244). 10 kHz: -20 dBV -2 to + 2 dB 15 kHz: -20 dBV -2 to + 3 dB 20 kHz: -20 dBV -2 to + 4 dB Refer to "Playback Frequency Response Adjustment" in item 5.3. 7. Conduct Step 13 "Playback Head Track and Azimuth Alignment". 8. Press the TEST button twice, then remove the Test Unit from CN-11.
16	Record Head Height Adjustment and Azimuth Alignment	400 Hz (0 dBV) and 15 kHz (-20 dBV) to Input Jacks	AC Voltmeter to Output Jacks	Rec./Play Monitor - Tape Tape - ZX Eq. - 70 μ s	RH Height Gear and Record Head Azimuth Alignment Screw	<ol style="list-style-type: none"> 1. Connect the Test Unit to CN-11 on the Logic P.C.B. Ass'y. 2. Press the TEST button on the Test Unit. 3. Press the CENTER button on the Test Unit. 4. Load a reference ZX tape and set the cassette deck in Rec./Play mode. 5. Feed in 400 Hz (0 dBV) to the Input Jacks. 6. Adjust the RH Height Gear to obtain maximum readings for both channels on the AC voltmeter. 7. Feed in 15 kHz (-20 dBV) to the Input Jacks. 8. Adjust the Record Head Azimuth Alignment Screw to obtain maximum readings for both channels on the AC voltmeter. 9. Repeat above 5 through 8 one or two times. 10. Press the TEST button twice, then remove the Test Unit from CN-11.

STEP	ITEM	SIGNAL SOURCE	OUTPUT CONNECTION	MODE	ADJUSTMENT	REMARKS
17	Phase Comparator Adjustment	400 Hz (0 dBV) to Input Jacks		Rec./Play Tape - ZX Monitor - Tape	Main P.C.B. VR304	<ol style="list-style-type: none"> 1. Connect the Test Unit to CN-11 on the Logic P.C.B. Ass'y. 2. Press the TEST button on the Test Unit. 3. Press the CENTER button on the Test Unit. 4. Feed in 400 Hz (0 dBV) to the Input Jacks. 5. Load a reference ZX tape and set the cassette deck in Rec./Play mode. 6. Adjust VR304 so that the Azimuth indicator lights up. 7. Press the TEST button twice, then remove the Test Unit from CN-11.
18	Record Level Calibration	400 Hz (0 dBV) to Input Jacks	AC Voltmeter to Output Jacks	Rec./Play Monitor - Source /Tape Tape - ZX/SX/EX Eq. - 70 μ s (ZX/SX) 120 μ s (EX)	Main P.C.B. ZX: VR101 VR201 SX: VR102 VR202 EX: VR103 VR203	<ol style="list-style-type: none"> 1. Connect the Test Unit to CN-11 on the Logic P.C.B. Ass'y. 2. Set the Tape selector to the ZX position and the Monitor selector to the Source position. 3. Feed in 400 Hz to the Input Jacks and adjust the Input Level controls to obtain 0 dBV (1 V) on the AC voltmeter. Set the Monitor selector to the Tape position. 4. Press the TEST button on the Test Unit. 5. Press the LEVEL button on the Test Unit. 6. Load a reference ZX tape and set the cassette deck in Rec./Play mode. 7. Press the Auto Calibration button. 8. After auto calibration is completed and the Ready indicator lights up, adjust VR101 (VR201) to obtain 0 dBV (1 V) on the AC voltmeter. 9. Change the cassette tape to a reference SX tape and set the Tape selector to the SX position. 10. Set the cassette deck in Rec./Play mode and press the Auto Calibration button. 11. After completion of auto calibration, adjust VR102 (VR202) to obtain 0 dBV (1 V) on the AC voltmeter. 12. Change the cassette tape to a reference EX tape and set the Tape selector to the EX position. 13. Set the cassette deck in Rec./Play mode and press the Auto Calibration button. 14. After completion of auto calibration, adjust VR103 (VR203) to obtain 0 dBV (1 V) on the AC voltmeter. 15. Press the TEST button twice, then remove the Test Unit from CN-11.

STEP	ITEM	SIGNAL SOURCE	OUTPUT CONNECTION	MODE	ADJUSTMENT	REMARKS
19	Record Amplifier Equalizer Adjustment	23 kHz (-20 dBV) to Input Jacks	AC Voltmeter to TP103, TP203 on Main P.C.B.	Rec./Pause Eq. - 70 μ s	Main P.C.B. L103 L203	<ol style="list-style-type: none"> 1. Remove the bias-cut jumper from the dip side of the Power Supply P.C.B. Ass'y. 2. Adjust L103 (L203) to obtain peak reading on the AC voltmeter. 3. Re-solder the bias-cut jumper.
20	Remote Control Receiver Gain Adjustment		Oscilloscope to TP302 on Receiver P.C.B.		Receiver P.C.B. L601 L602	<ol style="list-style-type: none"> 1. Remove the gain jumper from the dip side of the Receiver P.C.B. Ass'y. 2. While pressing the Play button of the Remote Control Unit, adjust L601 and L602 to obtain maximum amplitude on the Oscilloscope as shown below. 3. Resolder the gain jumper.



5.3. Playback Frequency Response Adjustment

Figs. 5.4 and 5.5 show the playback amp. circuit for adjustment and the playback equalization curve.

This adjustment will be required if playback level is not sufficient during playing back a 20 kHz PB frequency response tape.

The peaking portion of the equalization curve compensates the gap loss of the playback head. Peaking level can be varied by the shortcircuit of either R143 (R243) or R144 (R244) on the Main P.C.B. Ass'y.

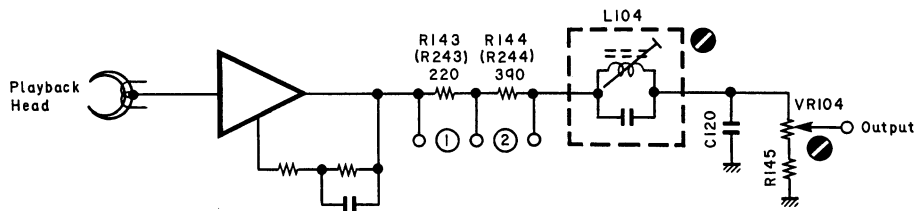

Fig. 5.4 Playback Amp.

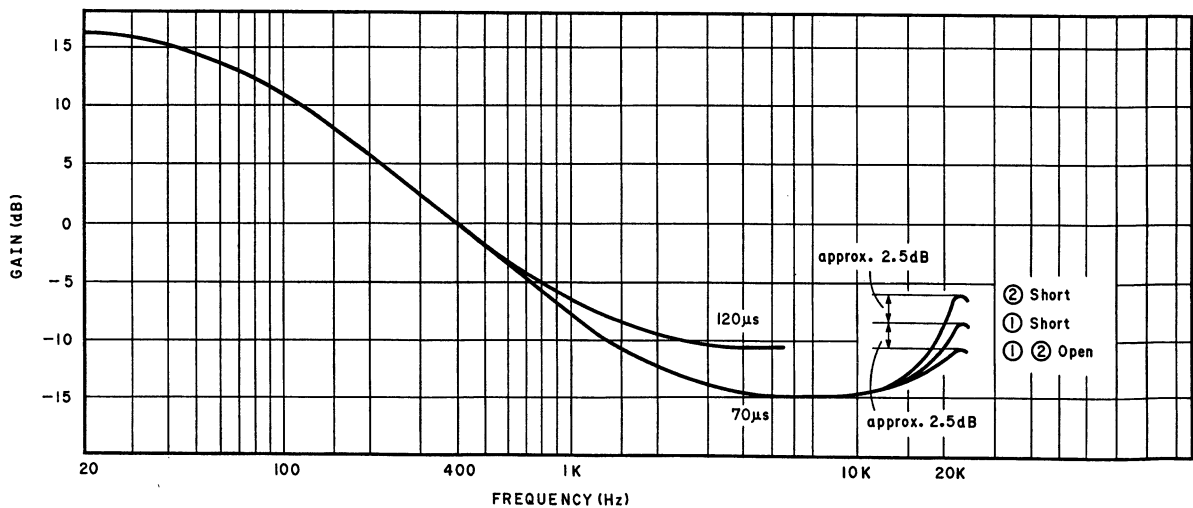

Fig. 5.5 Playback Eq. Curve

6. MECHANISM ASS'Y AND PARTS LIST

6.1. Synthesis

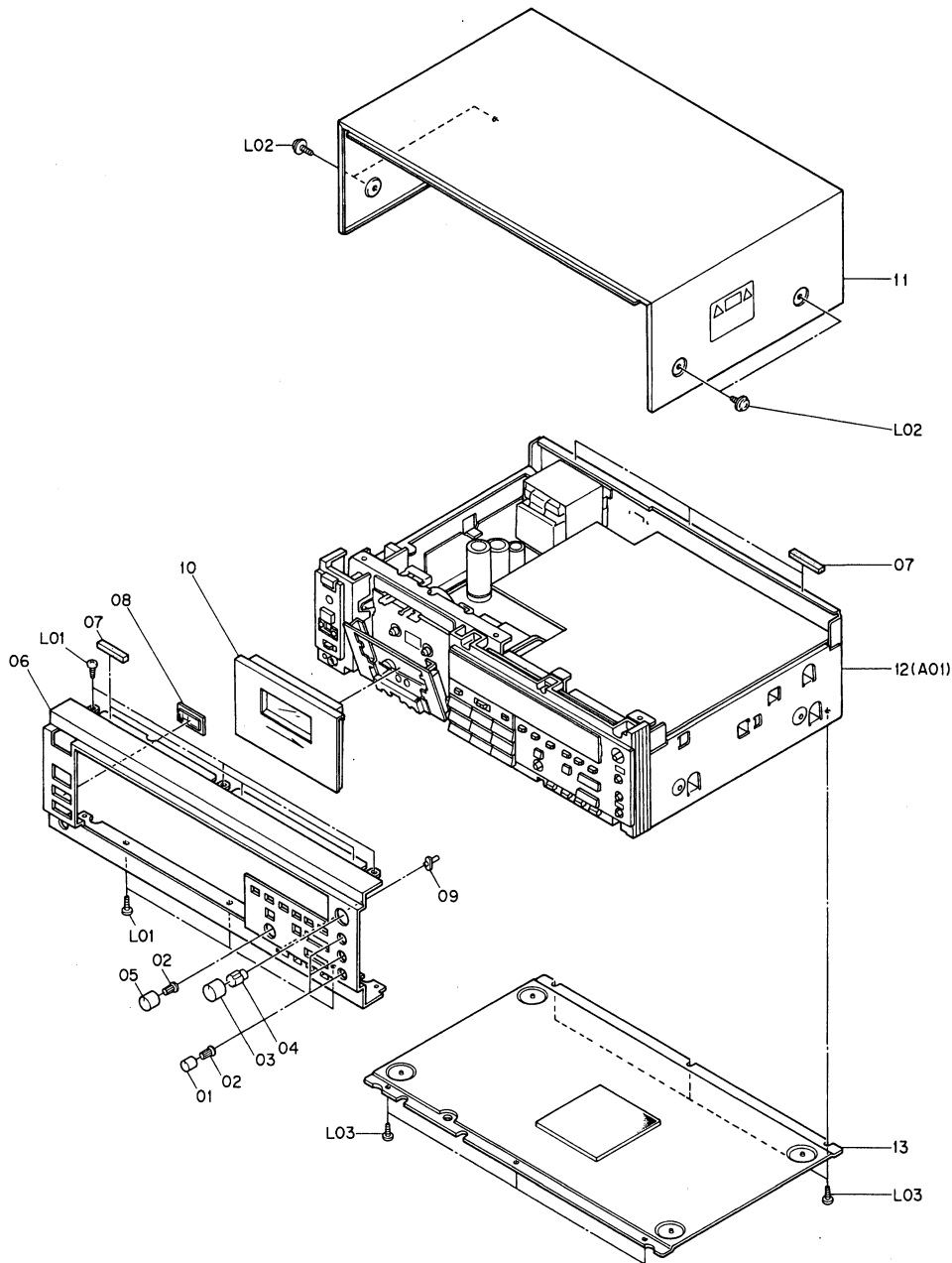

Fig. 6.1

Schematic Ref. No.	Part No.	Description	Q'ty	Schematic Ref. No.	Part No.	Description	Q'ty
		Synthesis			(OH04837B)	Top Cover	(1)
					(OM04377B)	Caution Label	(1)
					(OJ04753A)	Vibration Isolating Rubber	(1)
				12	—	Chassis Ass'y	1
				13	JA04197A	Bottom Cover Ass'y (consisting of the followings)	1
					(OJ05157B)	Bottom Cover	(1)
					(OJ03564A)	Leg T-H	(4)
					(OJ04833A)	Vibration Isolating Rubber B	(1)
					(OM04377B)	Caution Label	(1)
					(OE00865A)	BT3x10 @ Binding	(4)
					OJ05158A	Top Cover Cushion B	2
01	OH04342A	Volume Knob (S)	3	L01	OE00921A	BT3x8 @ Binding	6
02	OH03737A	Volume Knob Base (S)	4	L02	OE03032A	BT4x8 @ Pan Washer-faced (Black Chromate)	4
03	OH04716A	Volume Knob (L)	1	L03	OE00868A	BT3x8 @ Binding	6
04	OH03739A	Volume Knob Base	1				
05	OH04343A	Volume Knob (M)	1				
06	OH04781A	Front Panel CR-7	1				
	OH04797A	Front Panel CR-7A	1				
	OH04782A	Front Panel CR-7E	1				
	OH04792A	Front Panel CR-70	1				
07	OJ04550A	Top Cover Cushion A	6				
08	OH04777B	Remote Control Sensor Lens	1				
09	OH04767B	Lens	1				
10	HA04953A	Cassette Case Cover Ass'y	1				
11	HA05003A	Top Cover Ass'y (consisting of the followings)	1				

6.2. Chassis Ass'y (A01)

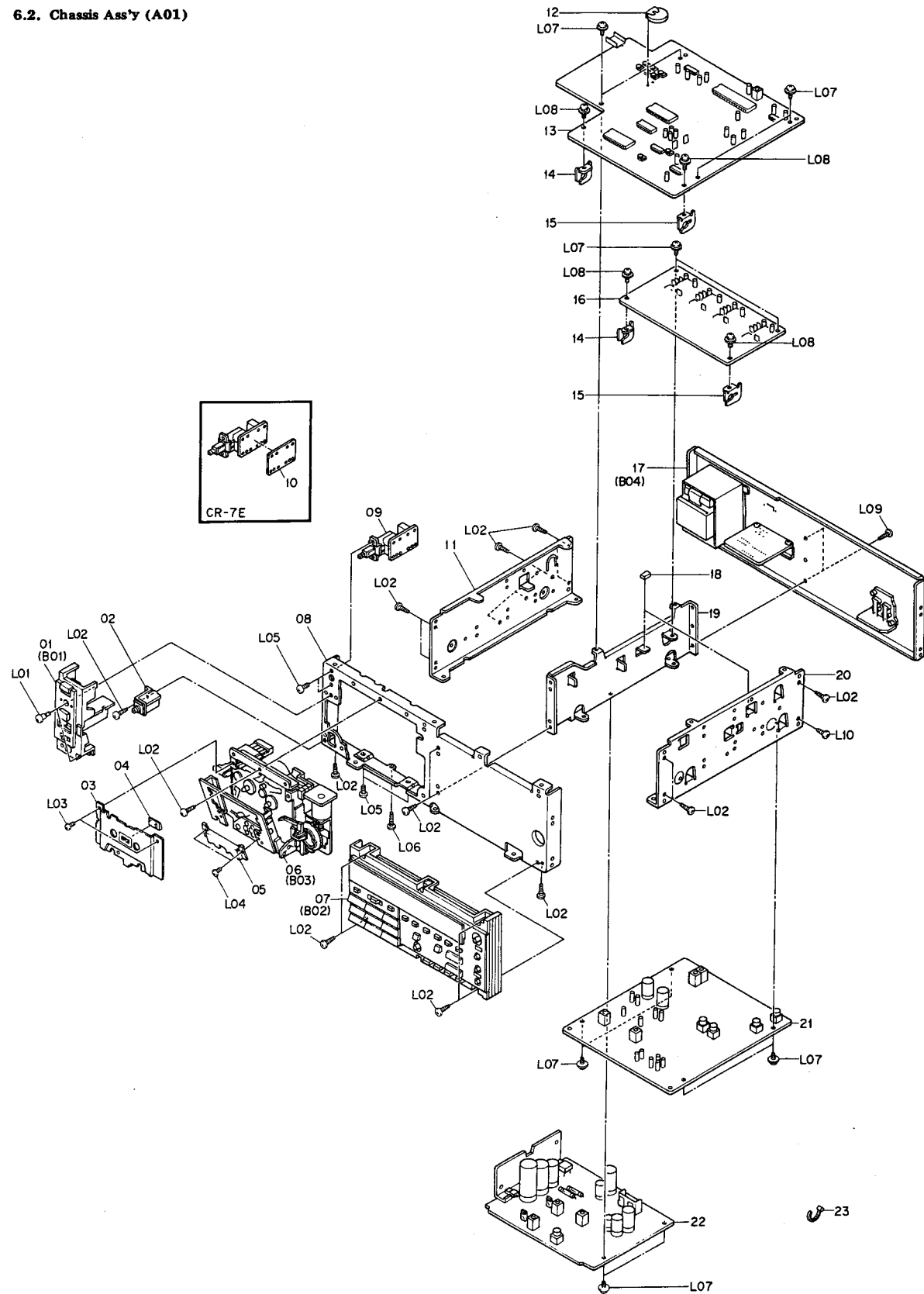

Fig. 6.2

6.3. Front Escutcheon L Ass'y (B01)

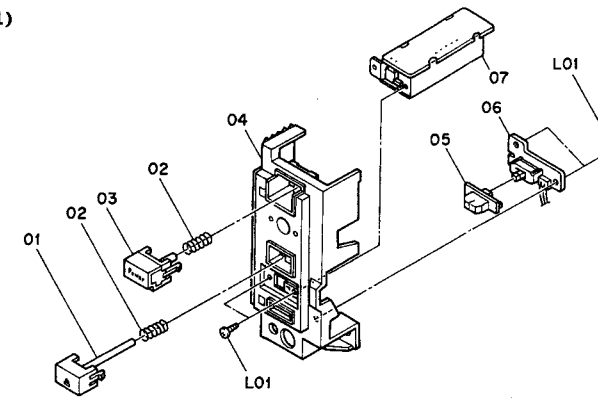

Fig. 6.3

Schematic Ref. No.	Part No.	Description	Q'ty	Schematic Ref. No.	Part No.	Description	Q'ty
A01	—	Chassis Ass'y	1	B01	HA04952A	Front Escutcheon L Ass'y Serial No.: A13001001 -	1
01	HA04952A	Front Escutcheon L Ass'y	1	01	HA04909C	Eject Button Ass'y	1
02	BA05918A	Headphone Jack P.C.B. Ass'y	1	02	OJ05084A	Eject Spring	2
03	OH04726B	Cover Plate	1	03	HA04908A	Power Switch Button	1
04	OH04722C	Lens	1	04	OH04740B	Front Escutcheon L	1
05	OH04415B	Head Mounting Cover	1	05	OH04745A	Slide Switch Knob	1
06	CA08761A	Mechanism Ass'y	1	06	BA05917A	Timer Switch P.C.B. Ass'y	1
07	HA04951A	Front Escutcheon R Ass'y	1	07	BA05916A	Receiver P.C.B. Ass'y	1
08	OJ05072B	Front Chassis	1	L01	OE00859A	BT2.6x6 @ Binding	4
09	BA05929A	Power Switch P.C.B. Ass'y CR-7 (Canada) & CR-7A	1				
	BA06072A	Power Switch P.C.B. Ass'y CR-7 (Australia & Others) & CR-7E (UK)	1				
	BA05930A	Power Switch P.C.B. Ass'y CR-7E (Europe)	1				
	BA05928A	Power Switch P.C.B. Ass'y CR-70	1				
10	OJ05107C	Insulator (CR-7E)	1				
11	OJ05073A	Side Chassis L	1				
12	OB90141A	Lithium Battery CR2032-FT	1				
13	BA05914A	Logic P.C.B. Ass'y	1				
14	OJ05080A	P.C.B. Holder L	2				
15	OJ05081A	P.C.B. Holder R	2				
16	BA05931A	Dolby NR P.C.B. Ass'y	1				
17	HA04974A	Rear Panel Ass'y CR-7 (Canada)	1				
	HA04947A	Rear Panel Ass'y CR-7 (Australia)	1				
	HA04946A	Rear Panel Ass'y CR-7 (Others)	1				
	HA04944A	Rear Panel Ass'y CR-7A	1				
	HA04943A	Rear Panel Ass'y CR-7E (UK)	1				
	HA04948A	Rear Panel Ass'y CR-7E (Europe)	1				
	HA04945A	Rear Panel Ass'y CR-70	1				
18	OJ05115A	P.C.B. Cushion	2				
19	OJ05075B	Center Chassis	1				
20	OJ05074A	Side Chassis R	1				
21	BA05932A	Main P.C.B. Ass'y	1				
22	BA05922A	Power Supply P.C.B. Ass'y CR-7 (Canada & Others) & CR-7A	1				
	BA05923A	Power Supply P.C.B. Ass'y CR-7 (Australia) & CR-7E	1				
	BA05921A	Power Supply P.C.B. Ass'y CR-70	1				
23	OB08515A	Insu-Lock	19				
—	OJ05144A	Motor Cushion A	1				
—	OJ05145A	Motor Cushion B	1				
L01	OE03135B	M3x8 @ Binding	2				
L02	OE00868A	BT3x8 @ Binding	20				
L03	OE00939A	BT2.6x4 @ Pan (Black Chromate)	2				
L04	OE03202A	M2.6x3 @ Binding (Black Chromate)	2				
L05	OE00896A	M3x6 @ Binding	4				
L06	OE00865A	BT3x10 @ Binding	1				
L07	OE03157A	BT3x8 @ Binding Washer-faced	12				
L08	OE00606A	M3x6 @ Pan (3A)	4				
L09	OE00921A	BT3x8 @ Binding (Black Chromate)	2				
L10	OE00857A	BT3x6 @ Binding	1				
—	OE00037A	Earth Lug B-5	1				

6.4. Side Mold R Assy (B02)

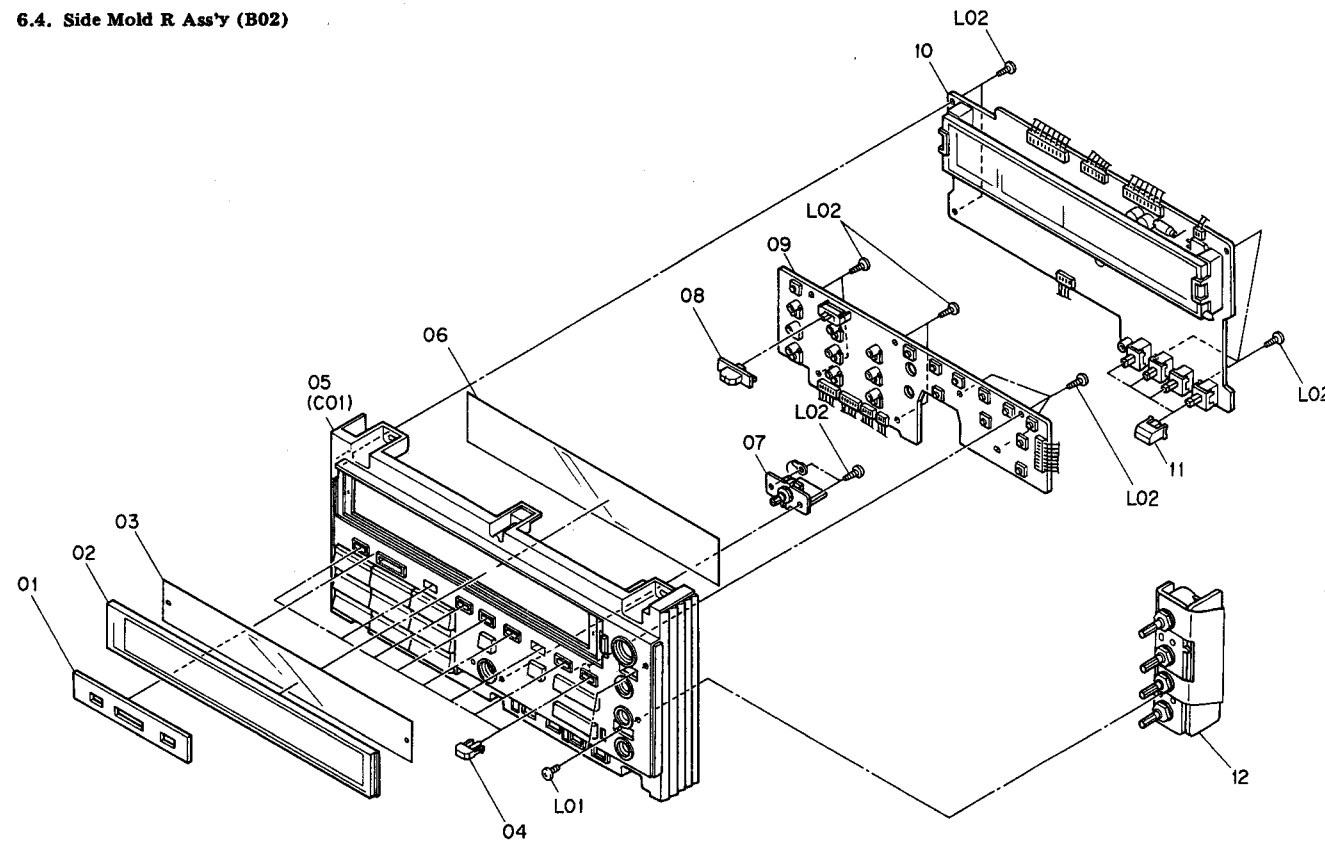

Fig. 6.4

Schematic Ref. No.	Part No.	Description	Qty
B02	HA04951A	Front Escutcheon R Assy Serial No.: A13001001 -	1
01	OH04778A	Front Plate	1
02	OH04711C	Display Lens	1
03	OJ05066B	Display Filter B	1
04	OH04736A	Push Button (S)	8
05	HA04957A	Front Escutcheon R Sub Assy	1
06	OJ05065A	Display Filter A	1
07	BA05920A	Azimuth Control P.C.B. Assy	1
08	OH04745A	Slide Switch Knob Assy	1
09	BA05926A	Control Switch P.C.B. Assy	1
10	BA05925A	Display P.C.B. Assy	1
11	OH04738A	Push Switch Button (L)	4
12	BA05919A	Volume P.C.B. Assy	1
L01	OE00896A	M3x6 @ Binding	2
L02	OE00857A	BT3x6 @ Binding	14

Schematic Ref. No.	Part No.	Description	Qty	Schematic Ref. No.	Part No.	Description	Qty
B03	CA08761A	Mechanism Assy Serial No.: A13001001 -	1	85	OC81392A	Mechanism Holder	1
01	OC81322A	Eject Lever Holder	1	86	OC81390A	Azimuth Arm	1
02	OC81321A	Eject Lever B	1	87	OC81395B	Azimuth Idler Gear	1
03	OC81323A	Eject Lever B Spring	1	88	OC81394A	Azimuth Chassis	1
04	OC80020A	Eject Lever A Spring	1	89	OC81397A	Azimuth Cam Gear	1
05	OC81465A	Eject Lever A	1	90	OC81401A	Thrust Spring C	1
06	CA80006A	Pneumatic Damper Assy	1	91	OC81398A	Limit Switch	2
07	OC80019A	Eject Spring	1	92	OB07240A	Volume 10K (B)	1
08	OC80018B	Cassette Case Holder L	1	93	CA80361A	Azimuth Motor P.C.B. Assy	1
09	OC80617A	Back Tension Arm Spring	1	94	OC81396A	Azimuth Motor	1
10	OC80618A	Back Tension Arm Collar	1	95	OC81400A	5P-H Connector	1
11	OC80619A	Back Tension Arm	1	96	OC80037A	Insu-Lock	3
12	OC80620A	Back Tension Pulley	1	97	OC81317A	7P-H Connector	1
13	OC80621A	Back Tension Belt	1	L01	OE03229A	FT2.5x6 @ Pan	18
14	OC80013A	Lock Lever Spring	1	L02	OE00181A	E-Ring 3mm	4
15	OC80014A	Lock Lever Collar	1	L03	OE03235A	Washer 2x5x0.25 (Plastics)	1
16	OC80015A	Lock Lever	1	L04	OE03052A	CS Stopper Ring 2.4mm	2
17	OC81421A	Height Adjustment Nut	1	L05	OE03236A	M2x5 @ Pan (2A)	4
18	CA80366A	Supply Pressure Roller Assy	1	L06	OE03043A	FT2.5x10 @ Pan	2
19	OC81420A	Supply Pressure Roller Spring	1	L07	OE03225A	Washer 1.8x3.8x0.5	1
20	OC81422A	Supply Pressure Roller Thrust Spring	1	L08	OE03226A	Washer 2.1x4.5x0.1	3
21	CA80201A	Take-up Reel Hub Assy	2	L09	OE00222A	E-Ring 2mm	1
22	OC80612A	Spring Holder	2	L10	OE03049A	Washer 1.8x3.2x0.5	2
23	OC80614A	Supply Reel Hub Spring	1	L11	OE00976A	M2x5 @ Binding	5
24	CA80200A	Cassette Case Assy	1	L12	OE00025A	Washer 2mm (Spring)	2
25	OC80762A	Head Height Adjustment Gear	2	L13	OE00117A	Washer 2x4.3x0.4	5
26	OC80761A	Head Height Adjustment Screw	4	L14	OE03018A	M2x5 @ Pan	1
27	OC80763A	Azimuth Alignment Screw	1	L15	OE00042A	E-Ring 1.5mm	5
28	OC81389A	Head Mount Plate	1	L16	OC80774A	Plate Washer L	1
29	CA08659B	R-3L Record Head Assy	1	L17	OC80773A	Plate Washer R	1
30	OC80776A	Head Plate Spring (L)	1	L18	OE03228A	FT3x4 @ Pan	1
31	OC81376A	4P-H Connector R	1	L19	OE03232A	M1.7x7 @ Pan	1
32	OC81326A	Lamp Holder	1	L20	OE03222A	Washer 1.8x3.8x0.3	1
33	OC81327A	Lamp	1	L21	OE03234A	M2x3 @ Pan	2
34	OC81402A	Rubber Cap	1	L22	OE03035A	M2x3.2 @ Truss	3
35	OC80003A	Head Base Hold Plate	1	L23	OE03227A	Washer 2.7x5x0.5	2
36	OC80004A	Steel Ball 3mm	1	L24	OE03231A	M2x30 @ Pan	2
37	GA02201A	E-4F Erase Head	1	L25	OE00698A	E-Ring 2.5mm	1
38	OC81387A	3P-H Connector E	1	L26	OE03041A	FT2.5x4 @ Pan	5
39	OC80768A	E.H. Hold Plate	1	L27	OE03233A	Washer 2.6x8x1	1
40	OC80889A	E.H. Hold Plate Tapering Spring	2	L28	OE03230A	ST2.6x12 @ Pan	1
41	OC80886A	E.H. Hold Plate Spring	1	L29	OE03245A	Washer 1.3x3.3x0.3 (Plastics)	1
42	OC80007A	Steel Ball 2mm	3	L30	OE03237A	Nut Hex. M2.6	1
43	OC80826D	Azimuth Alignment Screw	1	L31	OE03045A	M2.6x3 @ Binding	2
44	OC81391A	Azimuth Alignment Screw Stopper	1	L32	OE00694A	Nut Hex. M2	1
45	OC81393A	Azimuth Alignment Plate	1	L33	OE00691A	M2x3 @ Pan	5
46	CA08755A	P2H-3L Playback Head Assy	1	L34	OE03044A	FT2.5x20 @ Pan	1
47	OC80775A	Head Plate Spring R	1	L35	OC81404A	Washer 2.9x7.5x0.5	1
48	OC81375A	4P-H Connector P	1	L36	OE03062A	Washer 2.6mm (Plastics)	2
49	OC80771A	Tape Guide Plate	1	L37	OE00993A	Stopper Ring 6mm	1
50	CA80365A	Head Base Assy	1	L38	-	Nut	(1)
51	OC80613A	Take-up Reel Hub Spring	1	L39	-	Washer	(1)
52	CA80368A	Take-up Pressure Roller Assy	1	L40	OC81403A	M1.7x5 @ Pan	2
53	OC81423A	Take-up Pressure Roller Spring	1				
54	OC80610A	Cassette Case Spring	1				
55	OC81424A	Switch Hold Plate	1				
56	OC80623A	Switch Plate	1				
57	OC80626A	Leaf Switch	3				
58	OC81315A	Switch Collar C	2				
59	OC81320A	Metal Sensor Lever Spring	1				
60	OC81319A	Metal Sensor Lever	1				
61	OC80017B	Record Protector Lever	2				
62	CA80367A	Mechanism Chassis	1				
63	OC80022B	Cassette Hold Spring	1				
64	OC81325A	Mechanism Holder B	1				
65	CA80360A	Shut-off P.C.B. Assy	1				
66	CA80204A	Brake Assy	1				
67	OC80628A	Brake Spring B	1				
68	OC80630A	Brake Arm Collar	1				
69	OC80629A	Brake Arm	1				
70	OC80030A	Reel Motor Holder	1				
71	OC80635B	Idler Pulley	1				
72	CA80205A	Reel Motor Assy	1				
73	CA80364A	D.D. Motor Assy	1				
74	OC81388A	10P-H Connector	1				
75	OC81417A	Cam Gear B	1				
76	OC81418A	Control Motor Holder	1				
77	OC80027A	Mode Switch	1				
78	OC81416A	Thrust Spring B	1				
79	OC81419A	Joint Angle	1				
80	OC81415A	Thrust Bushing	1				
81	CA80007A	Control Motor Assy	1				
82	OC80010D	Cassette Case Holder R	1				
83	OC80012A	Eject Sensor	1				
84	OC81399A	Joint Arm	1				

6.6. Rear Panel Ass'y (B04)

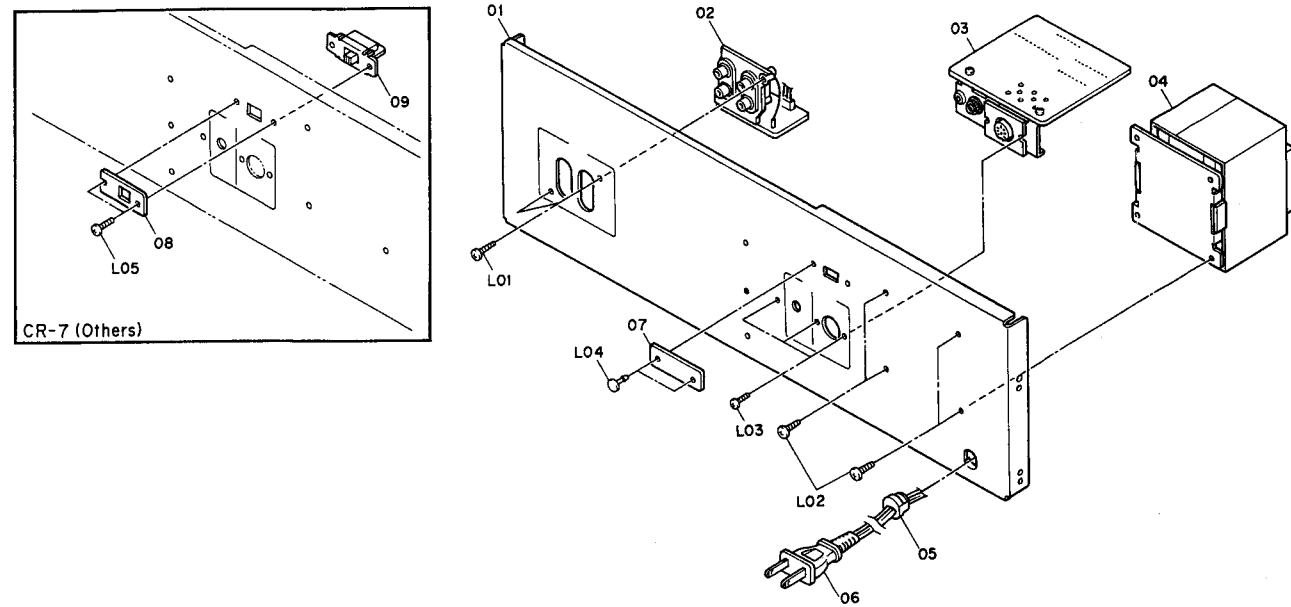

Fig. 6.6

6.7. Front Escutcheon R Sub Ass'y (C01)

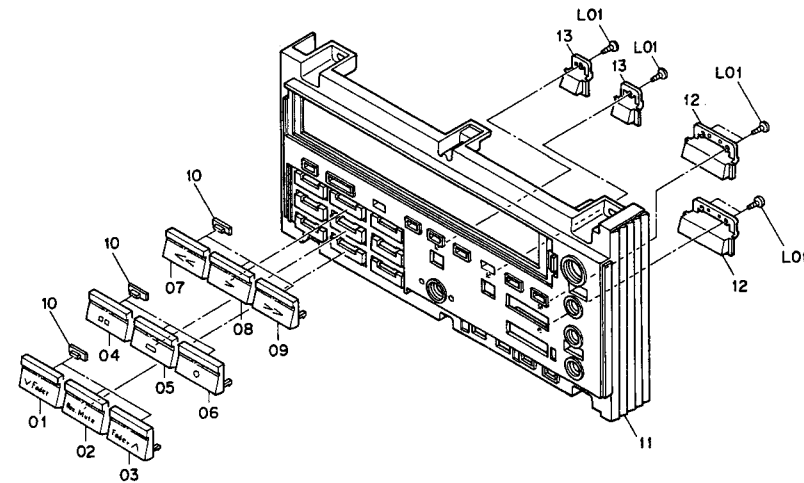

Fig. 6.7

6.8. D.D. Motor Ass'y (D01)

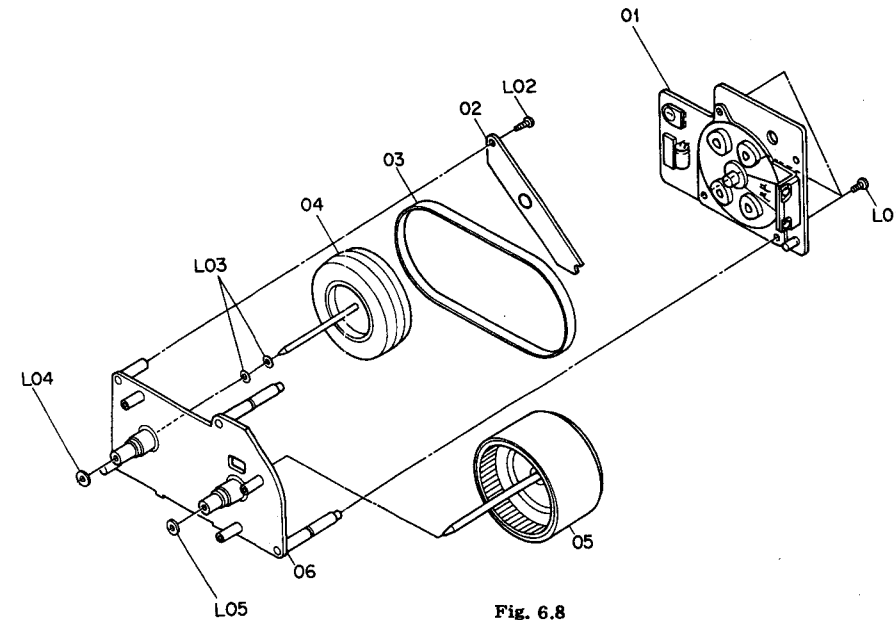

Fig. 6.8

Schematic Ref. No.	Part No.	Description	Qty
B04	HA04974A	Rear Panel Ass'y CR-7 (Canada)	1
	HA04947A	Rear Panel Ass'y CR-7 (Australia)	1
	HA04946A	Rear Panel Ass'y CR-7 (Others)	1
	HA04944A	Rear Panel Ass'y CR-7A	1
	HA04943A	Rear Panel Ass'y CR-7E (UK)	1
	HA04948A	Rear Panel Ass'y CR-7E (Europe)	1
	HA04945A	Rear Panel Ass'y CR-70 Serial No.: A13001001 -	1
01	OH04779D	Rear Panel CR-7	1
	OH04799C	Rear Panel CR-7A	1
	OH04780C	Rear Panel CR-7E	1
	OH04794D	Rear Panel CR-70	1
02	BA05927A	Pin Jack P.C.B. Ass'y	1
03	BA05915A	Remote Control P.C.B. Ass'y	1
04	OB50057A	Power Transformer CR-7 (Canada) & CR-7A	1
	OB50058A	Power Transformer CR-7 (Australia) & CR-7E	1
05	OB50059A	Power Transformer CR-7 (Others)	1
	OB50056A	Power Transformer CR-70	1
	OB08351A	Cord Bushing 4K-4 CR-7 (Canada), CR-7A & CR-7E (UK)	1
06	OB08037U	Cord Bushing C CR-7 (Australia & Others), CR-7E (Europe) & CR-70	1
	OB08504A	Power Cord CR-7 (Canada) & CR-7A	1
07	OB05241A	Power Cord CR-7 (Australia)	1
	OB08533A	Power Cord CR-7 (Others)	1
	OB08348A	Power Cord CR-7E (UK)	1
	OB08093U	Power Cord CR-7E (Europe)	1
	OB08219B	Power Cord CR-70	1
	OJ04601B	Switch Cover CR-7 (Canada & Australia), CR-7A & CR-7E	1
08	OM03948A	Voltage Lock Plate D CR-7 (Others)	1
09	OB07092U	Voltage Selector CR-7 (Others)	1
-	OF01071A	Free-up Belt CR-7 (Australia) & CR-7E (UK)	1
L01	OE00948A	BT 3x10 @ Binding (Black Chromate)	2
L02	OE00915A	BT 4x8 @ Binding (Black Chromate)	4
L03	OE03327A	M2.6x8 @ Binding (Black Chromate)	3
L04	OB08583A	Plastic Rivet (except CR-7 (Others))	2
L05	OE00818A	M3x8 @ Binding (Black Chromate) (except CR-7 (Others))	2
C01	HA04957A	Front Escutcheon R Sub Ass'y Serial No.: A13001001 -	1
01	OH04734B	Fader Button (Down)	1
02	OH04731B	Record Mute Button	1
03	OH04735B	Fader Button (Up)	1
04	OH04732B	Pause Button	1
05	OH04728B	Stop Button	1
06	OH04733B	Record Button	1
07	OH04730B	Rewind Button	1
08	OH04727B	Play Button	1
09	OH04729B	FF Button	1
10	OH04746A	Control Button Lens	9
11	OH04739C	Front Escutcheon R	1
12	OH04744A	Monitor Button	2
13	OH04737A	F Button B	2
L01	OE03328A	BT 2x5 @ Pan	6
D01	CA80364A	D.D. Motor Ass'y Serial No.: A13001001 -	1
01	OC81428A	Flywheel Holder P.C.B.	1
02	OC81464A	Supply Flywheel Holder	1
03	OC80634A	Capstan Belt	1
04	OC81429A	Supply Flywheel Ass'y	1
05	OC81427A	Take-up Flywheel Ass'y	1
06	OC81426A	Motor Plate Ass'y	1
L01	OE03349A	FT 3x5 @ Pan	3
L02	OE03229A	FT 2.5x6 @ Pan	1
L03	OE00912A	Washer 2.6x4.7x0.25 (Plastics)	2
L04	OE03348A	Capstan Washer S	1
L05	OE03051A	Washer 2.5x7x0.8	1

7. MOUNTING DIAGRAMS AND PARTS LIST

- Notes: 1. Mounting diagram shows a dip side view of the printed circuit board.
 2. Diode is 1SS53, 1S1555, or 1SS176 unless otherwise specified.
 3. Following transistors are interchangeable with each other.
 a. 2SA733, 2SA608SP, 2SA1048, 2SA1175
 b. 2SC945, 2SC536SP, 2SC2458, 2SC2785
 4. Abbreviation for part name:
 TR — Transistor, SiD — Silicon Diode, GD — Germanium Diode, ZD — Zener Diode
 RK — Carbon Resistor, RM — Metal Film Resistor, RF — Fail Safe Type Resistor, RW — Wire Wound Resistor
 CE — Electrolytic Capacitor, CM — Mylar Capacitor, CC — Ceramic Capacitor, CP — PP Capacitor,
 CT — Tantalum Capacitor, CF — Film Capacitor, C — Mica Capacitor

7.1. Power Switch P.C.B. Ass'y

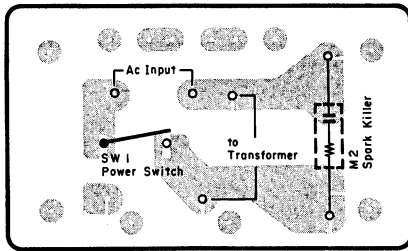

Fig. 7.1

7.2. Shut-off P.C.B. Ass'y

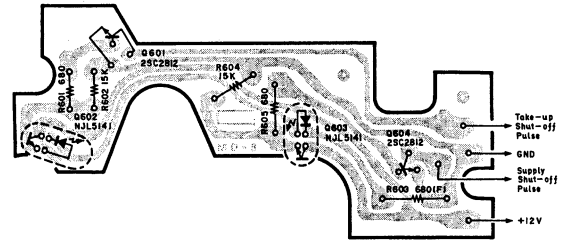

Fig. 7.2

7.3. Azimuth Motor P.C.B. Ass'y
 Mounting diagram is omitted.

7.4. Timer Switch P.C.B. Ass'y

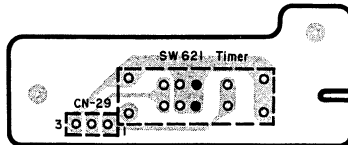

Fig. 7.3

7.5. Headphone Jack P.C.B. Ass'y

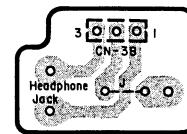

Fig. 7.4

7.6. Azimuth Control P.C.B. Ass'y

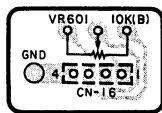

Fig. 7.5

Schematic Ref. No.	Part No.	Description	Schematic Ref. No.	Part No.	Description	Schematic Ref. No.	Part No.	Description
	BA05929A	Power Switch P.C.B. Ass'y CR-7 (Canada) & CR-7A		CA80360A	Shut-off P.C.B. Ass'y		BA05918A	Headphone Jack P.C.B. Ass'y
	BA06072A	Power Switch P.C.B. Ass'y CR-7 (Australia & Others) & CR-7E (UK)	Q601,604 Q602,603	0C80047A 0B06388A 0B06389A	Shut-off P.C.B. TR 2SC2812 Photoreflexor NJL5141	CN38	0B60287A 0B82585A 0B81478A 0J05077A	Headphone Jack P.C.B. 3P-H Connector Headphone Jack (1) Headphone Holder (1)
	BA05930A	Power Switch P.C.B. Ass'y CR-7E (Europe)	R601,605 R602,604 R603	0B09840A 0B09841A 0B22651A	RK 680 Leadless RK 15K Leadless RM 680 1/4W F		0J05092A	Snap Plate (1)
	BA05928A	Power Switch P.C.B. Ass'y CR-70		CA80361A	Azimuth Motor P.C.B. Ass'y		BA05920A	Azimuth Control P.C.B. Ass'y
SW1	OB60295A	Power Switch P.C.B.		0C81383A	Azimuth Motor P.C.B.		0B60289A	Azimuth Control P.C.B.
M2	OB70002A	Power Switch		0B06109A	SiD GP08B	VR601	0B30052A	Volume 10K (B)
M2	OB08342A	Spark Killer CR-7 (Canada) & CR-7A	D601,602 VR602 C601	0B32047A 0B09292A	Semi VR 2.2K (B) CC 0.1μ 50V Z	CN16	0B82565A	4P-H Connector
M2	OB08955A	Spark Killer CR-7 (Australia & Others) & CR-7E (UK)		BA05917A	Timer Switch P.C.B. Ass'y		0J05069A	Bias Plate (1)
M2	OB08445A	Spark Killer CR-7E (Europe)		0B60286A	Timer Switch P.C.B.		BA05950A	Earth Lug Ass'y (1)
M2	OB08363A	Spark Killer CR-70	SW621	0B07437A	Slide Switch 2-3			
	OB90059A	Spark Killer Cover CR-7E (Europe)	CN29	0B82578A	3P-H Connector			
	OE00752A	Eyelet 2x3 (2)						

7.7. Pin Jack P.C.B. Ass'y

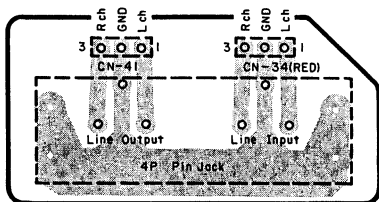

Fig. 7.6

7.8. Volume P.C.B. Ass'y

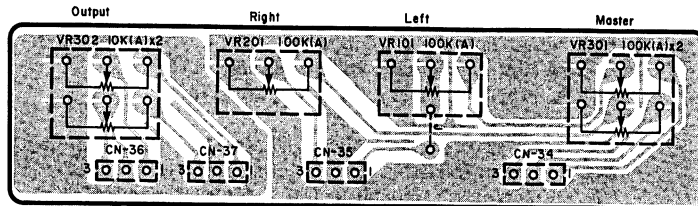

Fig. 7.7

7.9. Receiver P.C.B. Ass'y

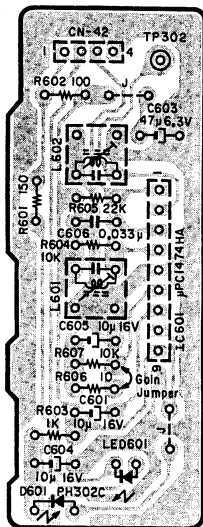

Fig. 7.8

7.10. Remote Control P.C.B. Ass'y

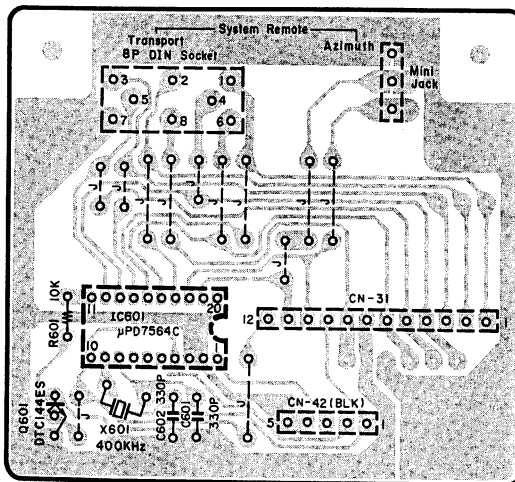

Fig. 7.9

Schematic Ref. No.	Part No.	Description	Schematic Ref. No.	Part No.	Description	Schematic Ref. No.	Part No.	Description
	BA05927A	Pin Jack P.C.B. Ass'y		BA05916A	Receiver P.C.B. Ass'y		BA05915A	Remote Control P.C.B. Ass'y
CN34	OB60294A	Pin Jack P.C.B.	IC601	OB60285B	Receiver P.C.B.		OB60284B	Remote Control P.C.B.
CN41	OB81229A	3P-T Post (Red)	D601	OB11192A	IC μ PC1474HA	IC601	OB11190A	IC μ PD7564C
	OB82587A	3P-H Connector	LED601	OB12352A	PIN Diode PH302C	Q601	OB10062A	TR DTC144ES
	OB81477A	4P Pin Jack (1)		OB12353A	LED (Green)	X601	OB02390A	Crystal 400kHz
	BA06082A	Earth Lug Ass'y (1)			SLB-26MG-N	R601	OB09701A	RK 10K 1/6W J
	BA05919A	Volume P.C.B. Ass'y	L601,602	OB51220A	L-C Block	C601,602	OB09285A	CC 330P 50V K
VR101,201	OB60288B	Volume P.C.B.	R601	OB09657A	RK 150 1/6W J	CN31	OB82580A	12P-H Connector
VR301	OB30050A	Volume 100K (A)	R602	OB09653A	RK 100 1/6W J	CN42	OB81192A	5P-S Post (Black)
VR302	OB30049A	Volume 100K (A)x2	R603	OB09677A	RK 1K 1/6W J		OB81479A	8P DIN Socket (1)
CN34	OB30051A	Volume 10K (A)x2	R604,607	OB09701A	RK 10K 1/6W J		OB81481A	Mini Stereo Jack (1)
CN35	OB82581A	3P-H Connector	R605	OB09709A	RK 22K 1/6W J		OJ05078A	DIN Bracket (1)
CN36	OB82582A	3P-H Connector	R606	OB09629A	RK 10 1/6W J		OE00868A	BT3x8 @ Binding (2)
CN37	OB82583A	3P-H Connector	C601,604	OB40009A	CE 10 μ 16V			
	OB82584A	2P-3PH Connector	605					
	OJ05068A	Volume Holder (1)	C603	OB40004A	CE 47 μ 6.3V			
	OJ05113A	Shield Plate (1)	C606	OB05583A	CM 0.033 μ 50V J			
			CN42	OB82588A	4P-5P Connector			
				OB81085A	Wire Mate 2P (1)			
				OJ05110A	Shield Case (1)			

7.12. Display P.C.B. Ass'y

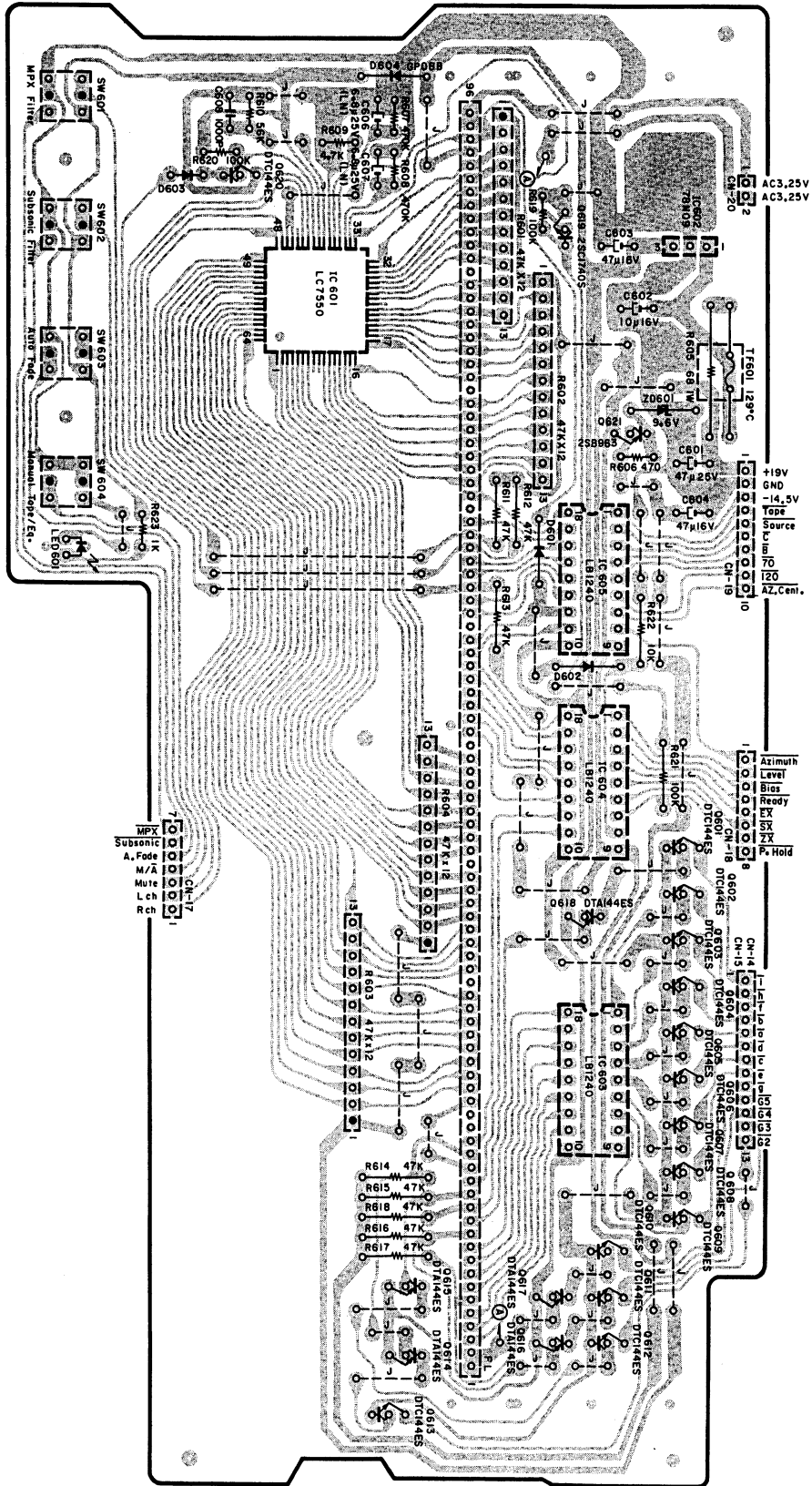

Fig. 7.11

Schematic Ref. No.	Part No.	Description
	BA05925A	Display F.C.B. Ass'y
	OB60291A	Display P.C.B.
IC601	OB11194A	IC LC7550
IC602	OB11195A	IC L78N09
IC603,604	OB11193A	IC LB1240
605		
Q601-613	OB10062A	TR DTC144ES
620		(14)
Q614,615	OB10053A	TR DTA144ES
616,617		
618		
Q619	OB10030A	TR 2SC1740S
		(Q,R,S,E)
Q621	OB10144A	TR 2SB963 (L,K)
ZD601	OB12272A	ZD 9.6V
		MTZ10B T-77
D601,602	OB06181A	SiD 1SS53
D603	OB06398A	SiD 1SS176
D604	OB06109A	SiD GP08B
LED601	OB12354A	LED (Red)
		SLR-34VR5
R601,602	OB21013A	R-Network 47Kx12
603,604		
R605	OB24021A	RF 68 1W J
R606	OB09669A	RK 470 1/6W J
R607,608	OB09741A	RK 470K 1/6W J
R609	OB09693A	RK 4.7K 1/6W J
R610	OB09719A	RK 56K 1/6W J
R611-618	OB05641A	RK 47K 1/4W J
		(8)
R619,620	OB09725A	RK 100K 1/6W J
R621	OB01889A	RK 100K 1/4W J
R622	OB01888A	RK 10K 1/4W J
R623	OB09677A	RK 1K 1/6W J
C601	OB40036A	CE 47 μ 25V
C602	OB40009A	CE 10 μ 16V
C603,604	OB40012A	CE 47 μ 16V
C606,607	OB09219A	CE 6.8 μ 25V (LN)
C608	OB05550A	CM 1000P 50V J
SW601,602	OB70014A	Push Switch
603,604		
TF601	OB08715A	Thermal Fuse 129 $^{\circ}$ C
CN14/15	OB82564A	13P-H Connector
CN17	OB82566A	7P-H Connector
CN18	OB82567A	8P-H Connector
CN19	OB82568A	10P-H Connector
CN20	OB82569A	2P-H Connector
	OB90169A	FL Indicator (1)
	OJ05067A	LED Holder (1)
	OJ05071C	Display Holder (2)
	OB05339B	3P Flat Cable (1)
	OE00857A	BT3x6 \otimes Binding (2)

Schematic Ref. No.	Part No.	Description	Schematic Ref. No.	Part No.	Description	
IC301 IC401 Q101,102 103,105 106,201 202,203 205,206 403,404 410 Q104,204 Q301 Q302,303 Q402,409 Q406 Q407,408 Q411 Q412,413 ZD101,201 ZD401 ZD402 ZD403,405 ZD404 ZD406 D101,201 301,302 303,405 408,409 D401 D402,403 406 D404,407 L101,201 L102,202 L301 VR101,201 VR102,202 VR103,104 203,204 R101,102 103,113 114,115 201,202 203,213 214,215 404,414 R104,204 301,422 R105,107 205,207 R106,206 R108,208 R109,110 209,210 R111,112 211,212 R116,216 R117,118 217,218 R302 R303 R304,305 R307,415 R308,309 R401,411 418,420 421 R402,412 R403,413 R406 R407 R408,416 R409 R410,417 R419 R423,424 R425,426 C101,201 C102,103 202,203	BA05922A	Power Supply P.C.B. Ass'y CR-7 (Canada & Others) & CR-7A	C104,204 C105,205 426 C106,206 C107,207 C301 C302,303 C304 C305 C307,308 C401 C402 C403,407 415,416 C404 C405 C406 C408,425 C409,410 C411 C412 C413,414 C417-424	OB09794A OB41394A OB09834A OB09322A OB09240A OB09191A OB09251A OB09248A OB05681A OB40365A OB40364A OB01272A OB41628A OB40362A OB40197A OB41386A OB40360A OB40361A OB40363A OB05831A OB09292A	CP 0.012 μ 100V J CP 220P 50V J CP 2200P 100V J CP 330P 100V J CP 0.033 μ 100V G CP 4700P 100V G CE 33 μ 25V CP 0.047 μ 100V J CM 0.01 μ 50V J CE 10000 μ 25V CE 6800 μ 25V CE 100 μ 25V C 10P 100V J CE 6800 μ 16V CE 4700 μ 25V CP 100P 50V J CE 1000 μ 16V CE 2200 μ 16V CE 2200 μ 25V CE 220 μ 35V CC 0.1 μ 50V Z Thermal Fuse 129 $^{\circ}$ C Fuse 2.5A Fuse 1A Dip Mate 6P 6P-H Connector 6P-H Connector Dip Mate 5P 5P-H Connector 3P-H Connector 6P-H Connector 3P-T Post 4P-T Post (Blue) 3P-T Post (White) 3P-H Connector (1) Dip Mate 3P (3) Dip Mate 2P (2) 3P Ribbon Cable (1) 2P Ribbon Cable (1) Insu-Lock 204mm Nut Hex. M3 (2) Heat Sink B (1) Heat Sink (1) M3x8 \otimes Pan (3A) BT3x8 \otimes Binding (5)	
		OB60290A OB06216A OB06217A OB01872A	Power Supply P.C.B. IC μ PC4556C IC μ PC4560D TR 2SC945L (P,Q)	TF101,201 F401,402 F403 CN4,5,40 CN4 CN5 CN6 CN6 CN7 CN40 CN43 CN44 TP104/204	OB08715A OB08962A OB08374A OB81013A OB82556A OB82557A OB81012A OB82558A OB82559A OB82586B OB81488A OB81476A OB81227A	
		OB06255A OB06069A OB06322A OB10107A OB10106A OB06013A OB06316A OB06303A OB12103A OB12147A	TR 2SD880 (Y) TR 2SB564 (L,M) TR 2SC2002 (K,L) TR 2SD1585 (L,K) TR 2SB1094 (L,K) TR 2SA733 (P,Q) TR 2SD882 (P,Q) TR 2SB772 (P,Q) ZD 2.7V RD2.7EB2 ZD 5.1V RD5.1JS-T1B2		OB82589A OB81010A OB81002A OB82120B OB82590A OB90005A	
		OB12153A	ZD 6.2V RD6.2JS-T1B2 ZD 15V MTZ15C ZD 20V MTZ20C ZD 5.6V RD5.6JS-T1B2 SID 1SS176		OE00507A OJ04485A OJ05079A OE00607A	
		OB12321A OB12330A OB12150A	ZD 15V MTZ15C ZD 20V MTZ20C ZD 5.6V RD5.6JS-T1B2 SID 1SS176		OE00868A	
		OB06398A	Diode Bridge DBA30 SiD GP08B		BA05923A	Power Supply P.C.B. Ass'y CR-7 (Australia) & CR-7E Contents is the same as BA05922A except for the following parts:
		OB06283A OB06109A	Diode Bridge DBA10 Bias Osc. Coil Trap Coil 1.05mH Erase Osc. Coil Semi VR 220K Semi VR 47K Semi VR 10K		OB02240A OB08457A OB08349B OM04096C OM04755A	Fuse T1.25A 250V Fuse T500mA 250V Fuse Clip (6) Fuse Label T500mA (1) Fuse Label T1.25Ax2 (1)
		OB06282A OB06646B OB06705A OB51221B	Diode Bridge DBA10 Bias Osc. Coil Trap Coil 1.05mH Erase Osc. Coil Semi VR 220K Semi VR 47K Semi VR 10K		BA05921A	Power Supply P.C.B. Ass'y CR-70 Contents is the same as BA05922A except for the following parts:
		OB09701A	RK 10K 1/6W J	F401,402 F403	OB08961A OB08686A	Fuse 2.5A Fuse 1A
		OB09685A	RK 2.2K 1/6W J			
		OB09927A	RM 100K 1/6W F			
		OB09725A OB09687A OB09697A	RK 100K 1/6W J RK 2.7K 1/6W J RK 6.8K 1/6W J			
		OB09737A	RK 330K 1/6W J			
		OB09629A OB05936A	RK 10 1/6W J RK 10 1/4W J			
		OB24016A OB24024A OB09727A OB09669A OB09212A OB09677A	RF 47 1W J R-Fuse 82 1/2W J RK 120K 1/6W J RK 470 1/6W J RF 2.2 1/4W J RK 1K 1/6W J			
		OB09689A OB09693A OB22357A OB09929A OB09695A OB09673A OB22347A OB09215A OB24087A OB24023A OB01913A OB01402A	RK 3.3K 1/6W J RK 4.7K 1/6W J RM 13.7K 1/6W F RM 10K 1/6W F RK 5.6K 1/6W J RK 680 1/6W J RM 11K 1/6W F RF 100 1/4W J R-Fuse 4.7 1/4W J R-Fuse 1 1/4W CM 1800P 50V J CE 4.7 μ 25V			

7.15. Main P.C.B. Ass'y

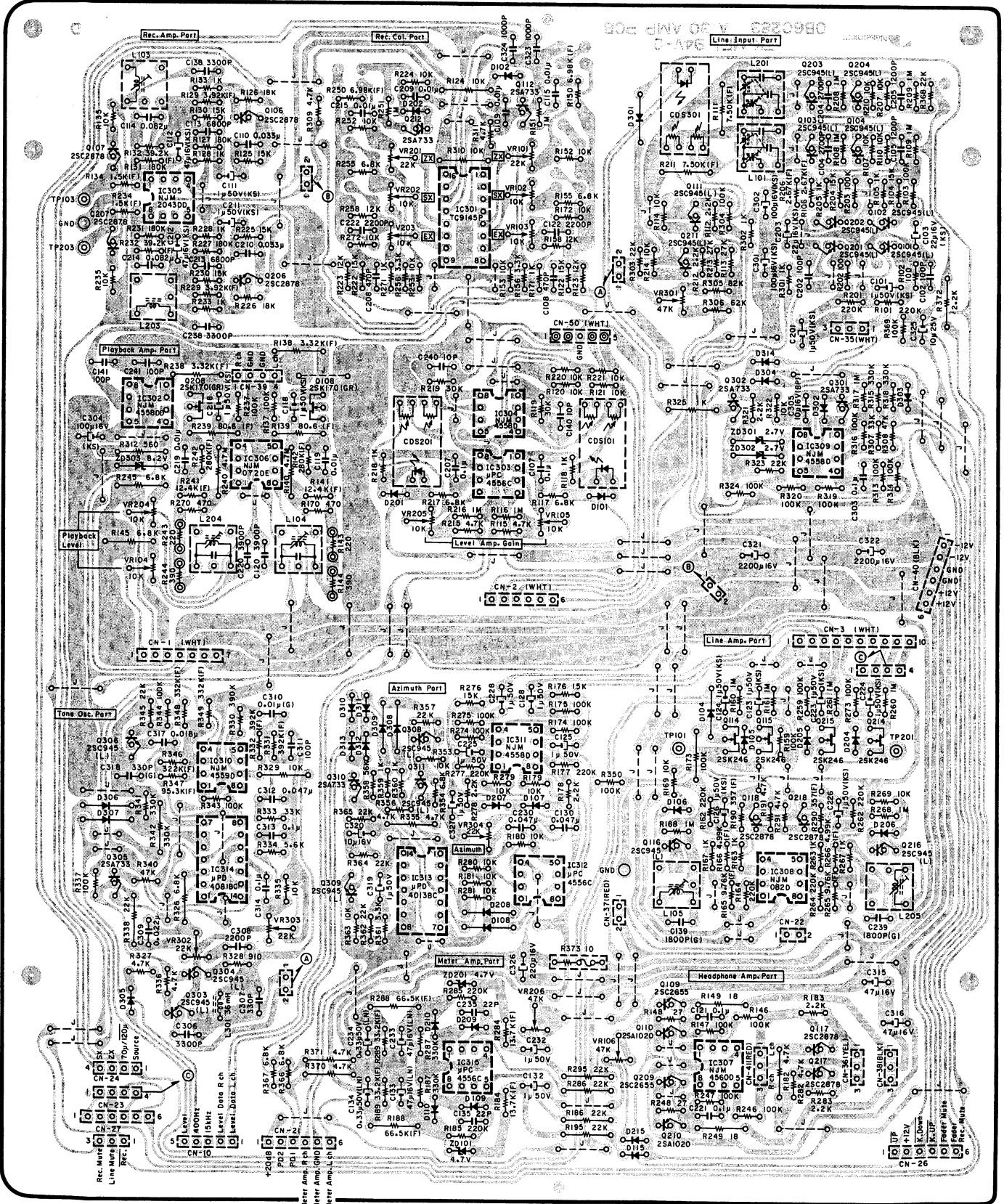

Fig. 7.14

Schematic Ref. No.	Part No.	Description	Schematic Ref. No.	Part No.	Description	Schematic Ref. No.	Part No.	Description	Schematic Ref. No.	Part No.	Description
IC601	BA05914A	Logic P.C.B. Ass'y	665,667			R675,676	OB09741A	RK 470K 1/6W J	CN20	OB81223A	2P-T Post (White)
	OB60296C	Logic P.C.B.	678,679			704,705			CN21	OB81242A	6P-T Post (Yellow)
	OB11020A	IC	681,682			706,707			CN22	OB81230A	3P-T Post (Yellow)
		TMP4315BP-1814	684,696			708,709			CN25	OB81233A	4P-T Post (Red)
	IC602,603	OB06214A	IC μ PD4071BC	697,711		794,809			CN27,29	OB81229A	3P-T Post (Red)
	IC604,605	OB06178A	IC μ PD4011BC	765,770		R686,688	OB09671A	RK 560 1/6W J	CN28	OB81249A	8P-T Post (Red)
	IC606	OB11189A	IC	771,772		729,787			CN30	OB81228A	3P-T Post (Black)
			TMP4740N-5222	774,776		799			CN31	OB81263A	12P-T Post (White)
	IC607	OB06396A	IC LC7800	780,784		R690,777	OB09705A	RK 15K 1/6W J	CN32	OB81480A	10P-T Post
	IC608	OB11188A	IC LC6510C-780	788,790		R691,694	OB09697A	RK 6.8K 1/6W J	CN33	OB02244A	7P-T Post
IC609	OB11191A	IC μ PD6326C-028	801,803		746,767			JP1	OB81019A	Dip Mate 8P (2)	
IC610	OB06457A	IC NJM072	815,817		R693	OB09689A	RK 3.3K 1/6W J	JP2,5	OB81011A	Dip Mate 4P (4)	
IC611	OB06144A	IC μ PD4066BC	818,819		R710	OB09721A	RK 68K 1/6W J	JP3	OB81013A	Dip Mate 6P (2)	
IC612,613	OB06124B	IC NJM4558D	827,831		R716	OB21014A	R-Network 47Kx4	JP4,6	OB81010A	Dip Mate 3P (4)	
614			841		R720	OB09217A	RF 5.6 1/4W J	JP1	OB82267A	Ribbon Cable 4P (2)	
Q601,604	OB10030A	TR 2SC1740S (Q,R,S,E)	R603,606	OB09737A	RK 330K 1/6W J	R723,724	OB09669A	RK 470 1/6W J	JP2	OB82596A	Ribbon Cable 4P
605,606			616,617			742,743		JP3	OB82643A	Ribbon Cable 6P	
607,618			628,629			749		JP4	OB82093B	Ribbon Cable 3P	
633,649			702			R725	OB05836A	RK 2.7 1/4W J	JP5	OB82593A	Ribbon Cable 4P
650,681			R607,613	OB09693A	RK 4.7K 1/6W J	R726	OB06706A	RW 3.5	JP6	OB82591A	Ribbon Cable 3P
Q602,621	OB10053A	TR DTA144ES	626,627			R730	OB09663A	RK 270 1/6W J		OB90134B	Heat Sink for Q648 (1)
624,628			670,673			R732,750	OB09711A	RK 27K 1/6W J			
629,630			674,698			R733	OB09699A	RK 8.2K 1/6W J			
634,635			699,715			R737	OB09715A	RK 39K 1/6W J			
659,674			R608,782	OB09719A	RK 56K 1/6W J	R739	OB09831A	RF 22 1W J			
675,676			786			R747	OB24023A	R-Fuse 1 1/4W			
677			R609,712	OB09713A	RK 33K 1/6W J	R768,837	OB09685A	RK 2.2K 1/6W J			
Q603,619	OB10026A	TR 2SA933S (Q,R,S)	713,736			R778	OB09722A	RK 75K 1/6W J			
623,625			R610,611	OB09701A	RK 10K 1/6W J	R789,802	OB22531A	RM 453K 1/6W F			
627,631			619,637			R791,804	OB22457A	RM 100K 1/6W F			
632,636			651,653			R797,810	OB09703A	RK 12K 1/6W J			
653,654			661,685			835					
678,679			689,695			R812	OB22073A	RM 43.2 1/6W F			
680,682			700,763			R813	OB22139A	RM 169 1/6W F			
686,687			773,775			R814	OB22229A	RM 1K 1/6W F			
Q608,609	OB10060A	TR DTA143ES	779,781			R820	OB22220A	RM 825 1/6W F			
Q610,611	OB10058A	TR DTA114ES	783,785			R821,836	OB22361A	RM 15K 1/6W F			
612,613			792,793			838					
614			798,805			R822	OB22469A	RM 130K 1/6W F			
Q615	OB10008A	TR 2SC3401	806,811			R824	OB22366A	RM 16.5K 1/6W F			
Q616,617	OB06322A	TR 2SC2002 (K,L)	816,823			R832	OB05671A	RK 2.2M 1/4W J			
684			825,826			R844	OB09653A	RK 100 1/6W J			
Q620,622	OB10062A	TR DTC144ES (25)	828,833			C601,602	OB09222A	CE 0.47 μ 50V (LN)			
626			834,839			631,632					
637-643			R612,649	OB09717A	RK 47K 1/6W J	C603,609	OB09223A	CE 1 μ 50V (LN)			
658			652,660			C604,605	OB09332A	CE 2.2 μ 50V (LN)			
660-673			663,683			617					
Q644,645	OB10015A	TR 2SA1020 (O,Y)	714,734			C606,607	OB09286A	CC 470P 50V K			
651,652			751,752			608					
Q646,647	OB06429A	TR 2SC2655 (Y)	753,754			C610	OB09148A	CE 10 μ 25V (LN)			
655,656			755,759			C611,650	OB01403A	CE 47 μ 16V			
Q648,657	OB06371A	TR 2SD1286 (L,K)	760,761			651					
Q683	OB06129A	FET 2SK117	762,764			C612,618	OB09868A	CF 0.1 μ 50V J			
Q685	OB06372A	TR 2SA953 (K,L)	829			623,628					
ZD601	OB12305A	ZD 9.1V MTZ9.1A	R614,615	OB09677A	RK 1K 1/6W J	634,636					
D601-621	OB06398A	SiD 1SS176 (69)	722,728			639					
623,624			741,745			C613	OB05583A	CM 0.033 μ 50V J			
626-632			795,808			C614,621	OB05582A	CM 0.022 μ 50V J			
634,635			840			622					
638,639			R618,624	OB09749A	RK 1M 1/6W J	C619,620	OB05557A	CM 0.015 μ 50V J			
640,644			631,632			C625,626	OB01527A	CE 22 μ 25V			
647-651			633,703			C627	OB01674A	CE 10 μ 25V			
653-665			769,830			C629,630	OB09285A	CC 330P 50V K			
669-677			R620,621	OB05641A	RK 47K 1/4W J	C633,648	OB05681A	CM 0.01 μ 50V J			
679-684			622,721			C635	OB40079A	CE 220 μ 16V			
D622,633	OB06181A	SiD 1SS53	727,740			C637,638	OB09279A	CC 22P 50V K			
636,637			744,756			C640,641	OB09905A	CC 120P 50V K			
645,646			757,758			C642,645	OB05796A	CM 0.047 μ 50V J			
666,667			R634	OB09735A	RK 270K 1/6W J	C643,644	OB09144A	CE 0.22 μ 50V (LN)			
668,678			R635,650	OB09733A	RK 220K 1/6W J	646,647					
D652			655,669			C649	OB01405A	CE 1 μ 50V			
X601	OB06109A	SiD GP08B	672			C652,653	OB09292A	CC 0.1 μ 50V Z			
X602	OB90009A	Crystal 4.1943MHz	R638,639	OB09667A	RK 390 1/6W J	CN4,26	OB81241A	6P-T Post (Red)			
L601	OB02307A	Crystal 800kHz	692			CN5,23	OB81239A	6P-T Post (White)			
VR601	OB06689A	L-C Block (Black)	R640,641	OB09661A	RK 220 1/6W J	CN6	OB81235A	5P-T Post (White)			
VR602	OB32056A	Semi VR 470	642,643			CN7	OB81227A	3P-T Post (White)			
VR603,604	OB32058A	Semi VR 2.2K	644			CN8	OB02243A	5P-T Post			
606	OB32061A	Semi VR 10K	R645	OB09665A	RK 330 1/6W J	CN9	OB81245A	7P-T Post (Red)			
VR605,607	OB32064A	Semi VR 47K	R646,731	OB09695A	RK 5.6K 1/6W J	CN10	OB81237A	5P-T Post (Red)			
609			R647,738	OB09707A	RK 13K 1/6W J	CN11	OB81236A	5P-T Post (Black)			
VR608	OB32065A	Semi VR 100K	842			CN12	OB81240A	6P-T Post (Black)			
R601,604	OB09687A	RK 2.7K 1/6W J	R654,664	OB09709A	RK 22K 1/6W J	CN13	OB81232A	4P-T Post (Black)			
625			677,680			CN14,24	OB81231A	4P-T Post (White)			
R602,605	OB09725A	RK 100K 1/6W J	687			CN15	OB81251A	9P-T Post (White)			
623,630			R666,843	OB09691A	RK 3.9K 1/6W J	CN16	OB81234A	4P-T Post (Yellow)			
636,648			R668,671	OB09727A	RK 120K 1/6W J	CN17	OB81243A	7P-T Post (White)			
656,662			701,735			CN18	OB81247A	8P-T Post (White)			
						CN19	OB81255A	10P-T Post (White)			

8. SCHEMATIC DIAGRAMS

8.1. IC Block Diagrams

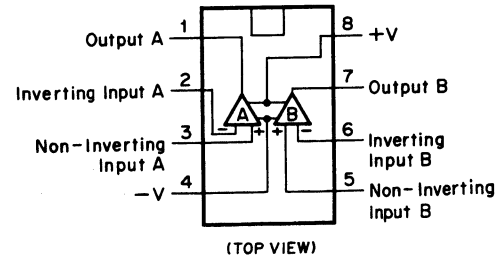

Fig. 8.1.1 Operational Amp. IC 4558D, 4558DD, 4559D, 4556C, 4560D, 2043DD, 072, 072DE, 082D

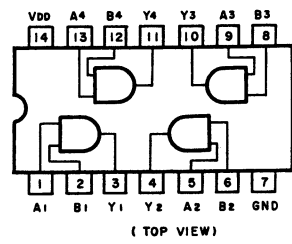

Fig. 8.1.2 AND Gate C-MOS IC μ PD4081BC

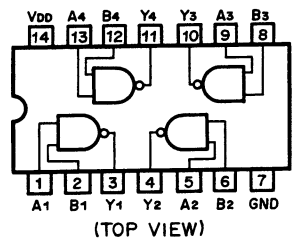

Fig. 8.1.3 NAND Gate C-MOS IC μ PD4011BC

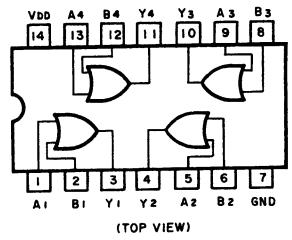

Fig. 8.1.4 OR Gate C-MOS IC μ PD4071BC

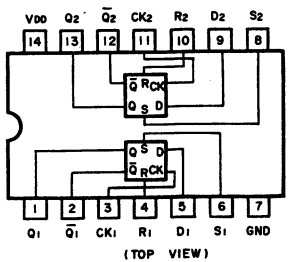

Fig. 8.1.5 D-Type Flip-Flop C-MOS IC μ PD4013BC

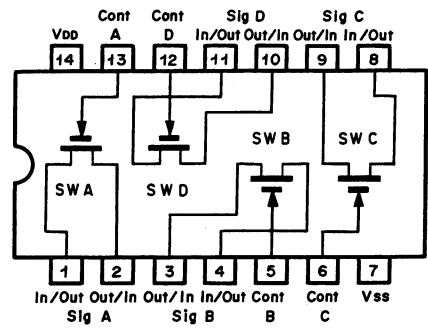

Fig. 8.1.6 Bilateral Switch C-MOS IC μ PD4066BC

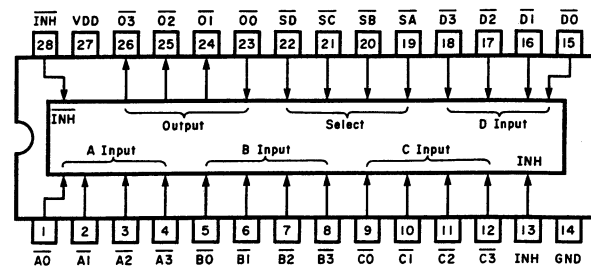

Fig. 8.1.7 Input Port Expander LC7800

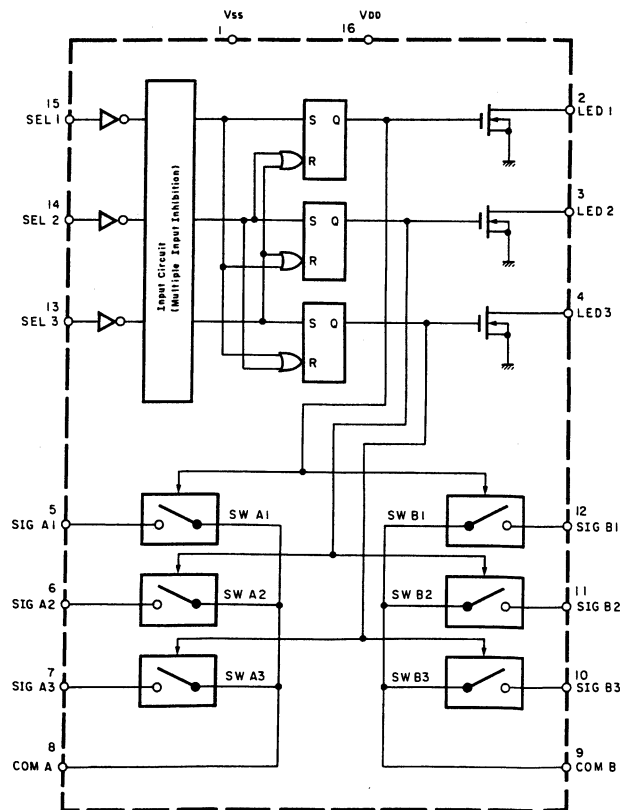

Fig. 8.1.8 Analog Switch Selector TC9145P

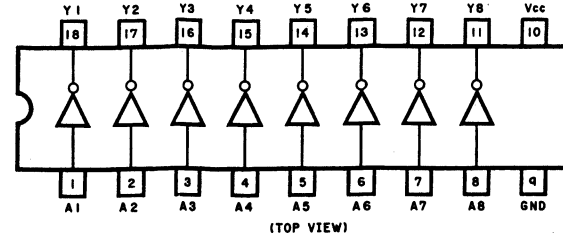

Fig. 8.1.9 FL Display Tube Driver LB1240

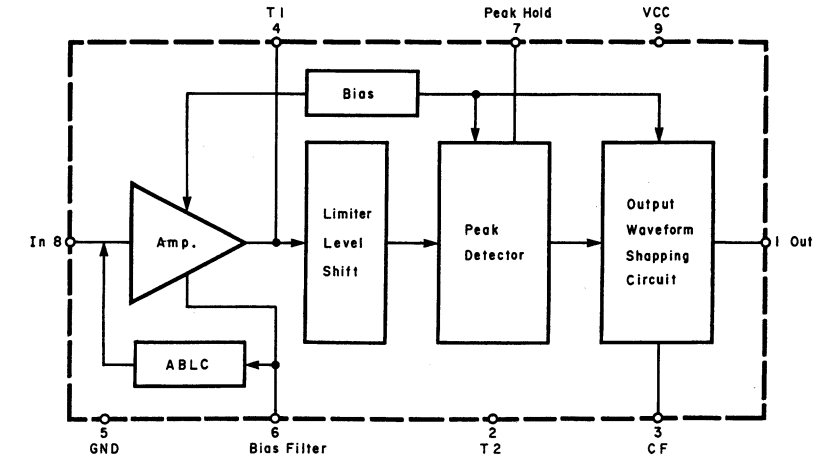

Fig. 8.1.10 Pre-amp. IC μ PC1474HA

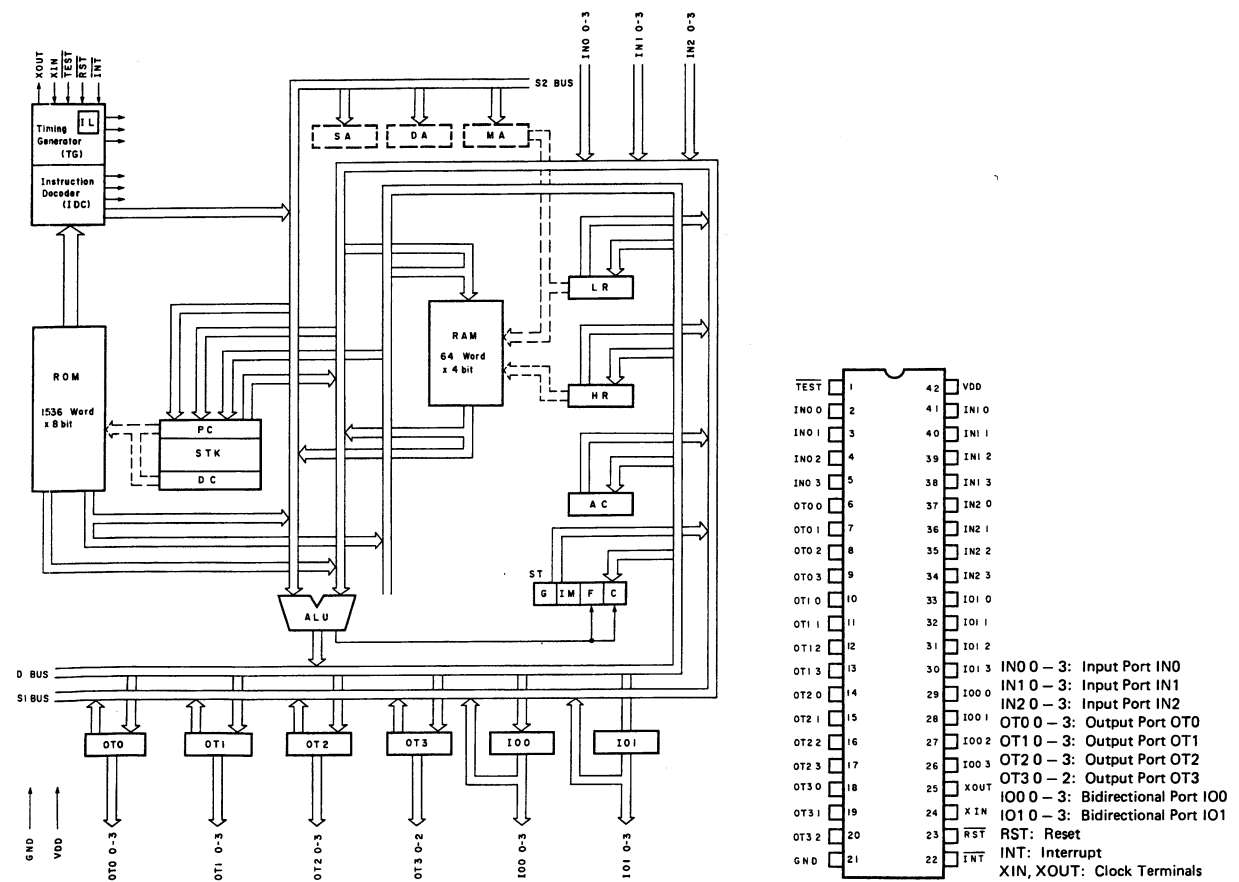

Fig. 8.1.11 4-Bit Micro-processor TMP4315BP-1814

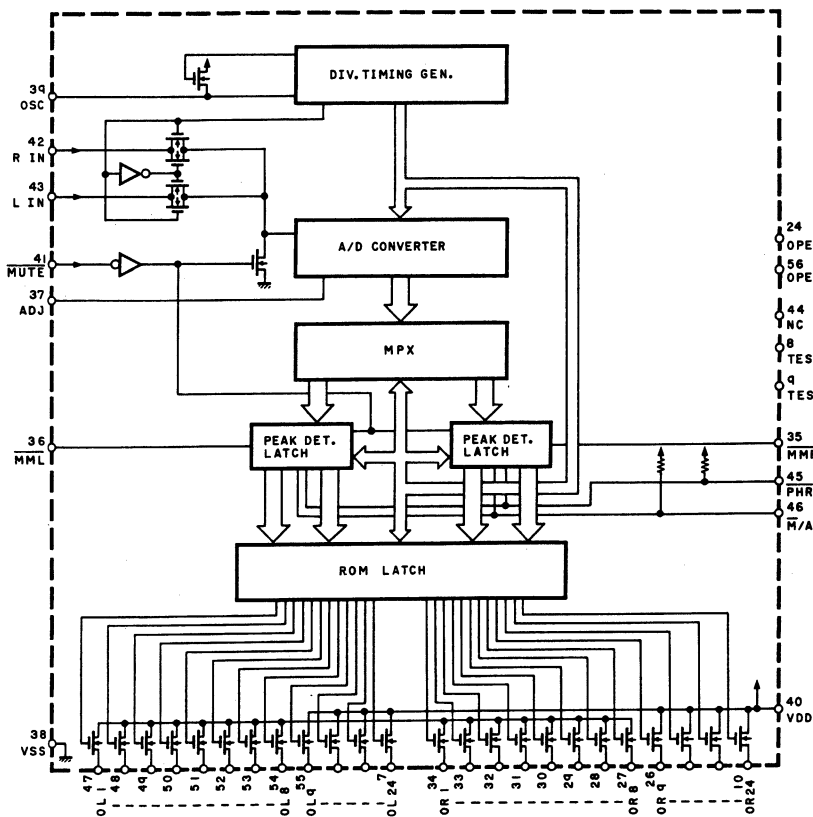

Fig. 8.1.12 Level Meter Controller LC7550

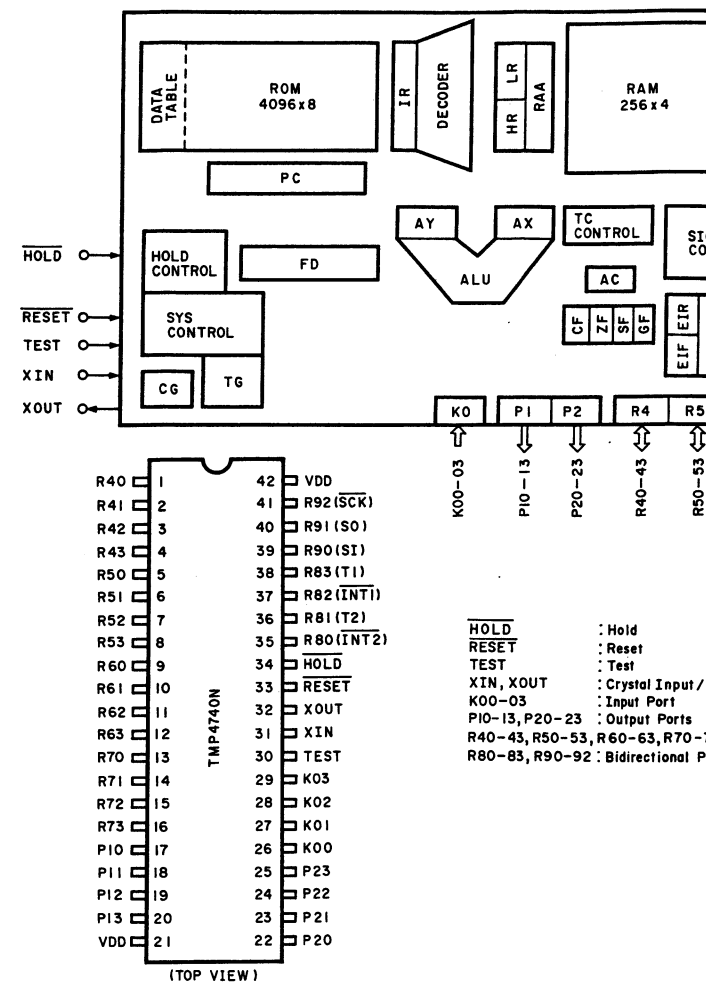
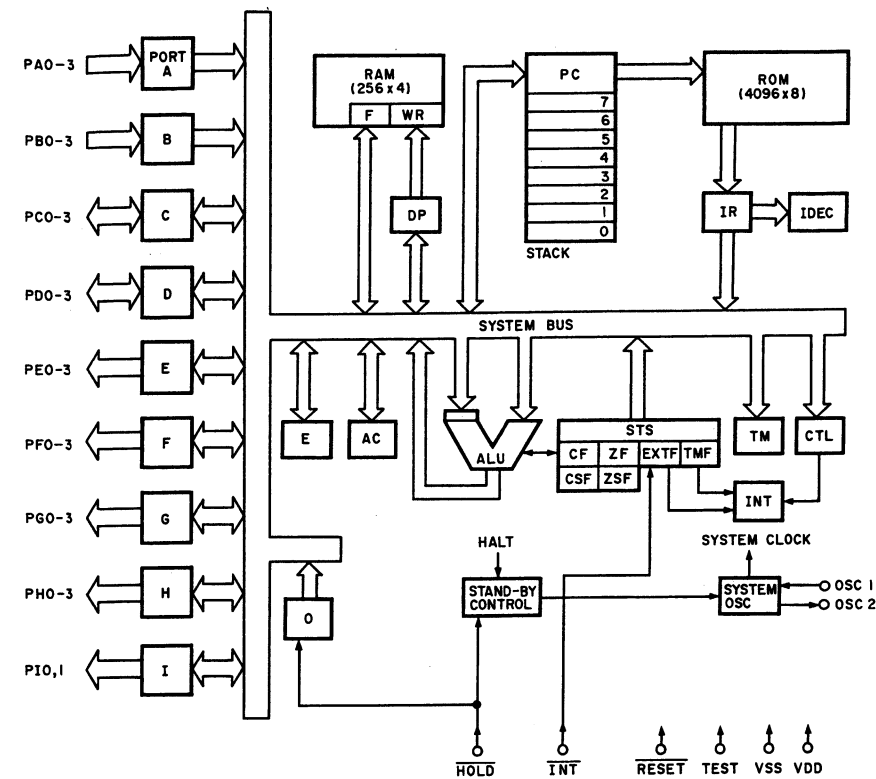

Fig. 8.1.15 4-Bit Micro-processor TMP4740N-5222

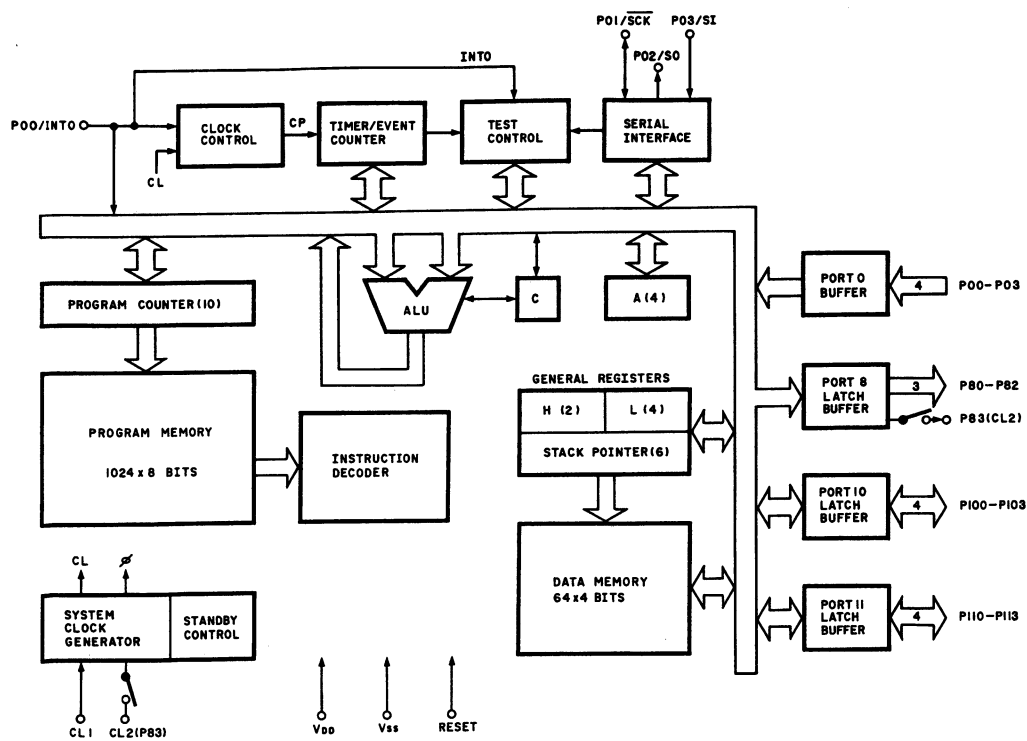

Fig. 8.1.13 4-Bit Micro-processor μPD7564C

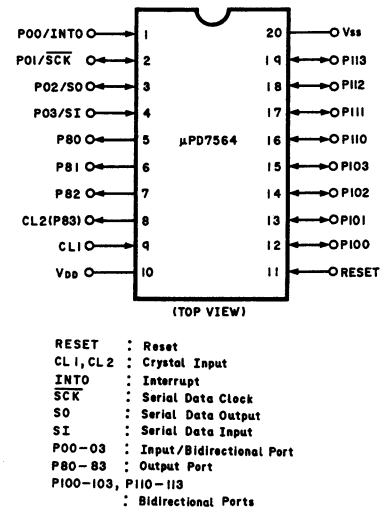

Fig. 8.1.14 4-Bit Micro-processor LC6510C-780

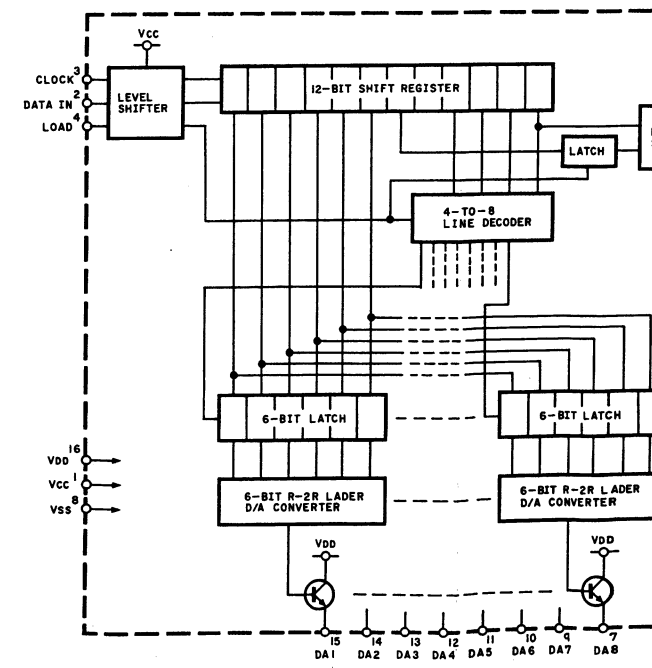

Fig. 8.1.16 μPD6326C-028

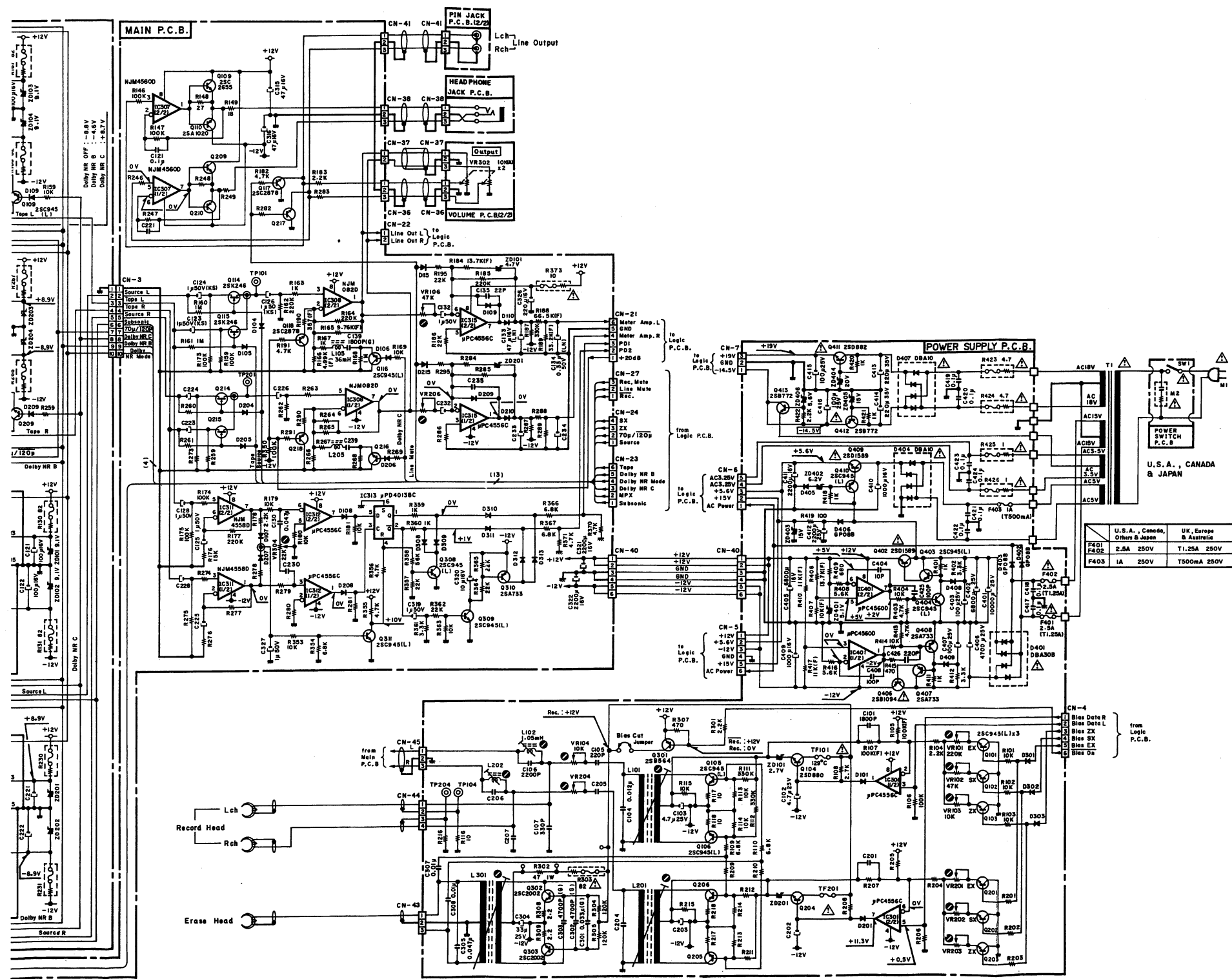
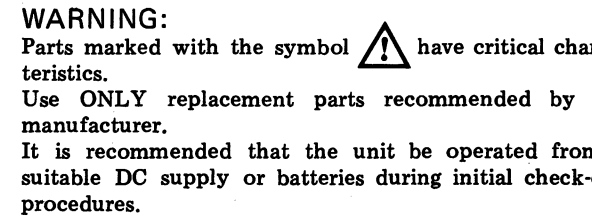
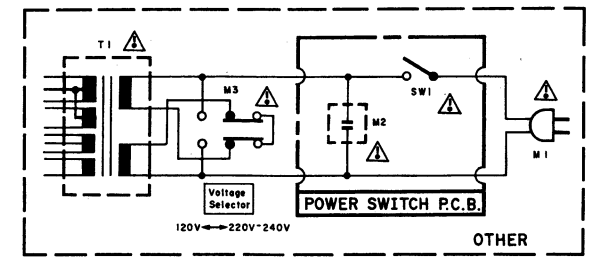
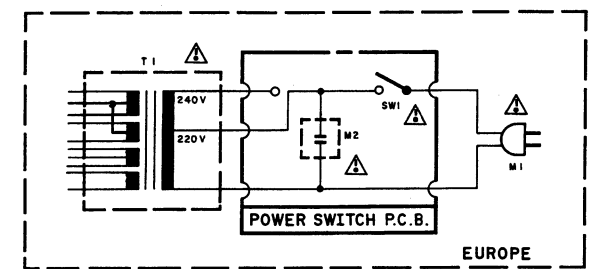
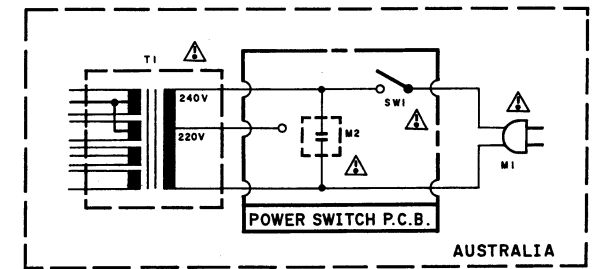
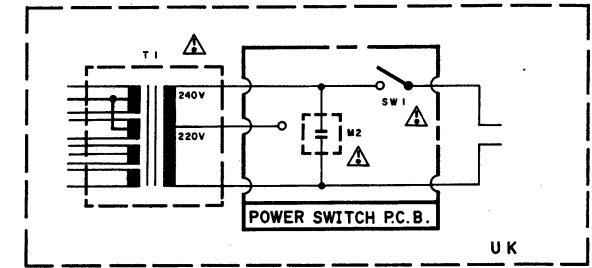



Fig. 8.2.2



WARNING:
 Parts marked with the symbol  have critical characteristics. Use **ONLY** replacement parts recommended by the manufacturer. It is recommended that the unit be operated from a suitable DC supply or batteries during initial check-out procedures.

CAUTION:
 Before returning the unit to the customer, make sure you make either (1) a leakage current check or (2) a line to chassis resistance check. If the leakage current exceeds 0.5 milliamp, or if the resistance from chassis to either side of the power cord is less than 240 k ohms, the unit is defective. **WARNING — DO NOT** return the unit to the customer until the problem is located and corrected.

8.2.3. Mechanism Control Section

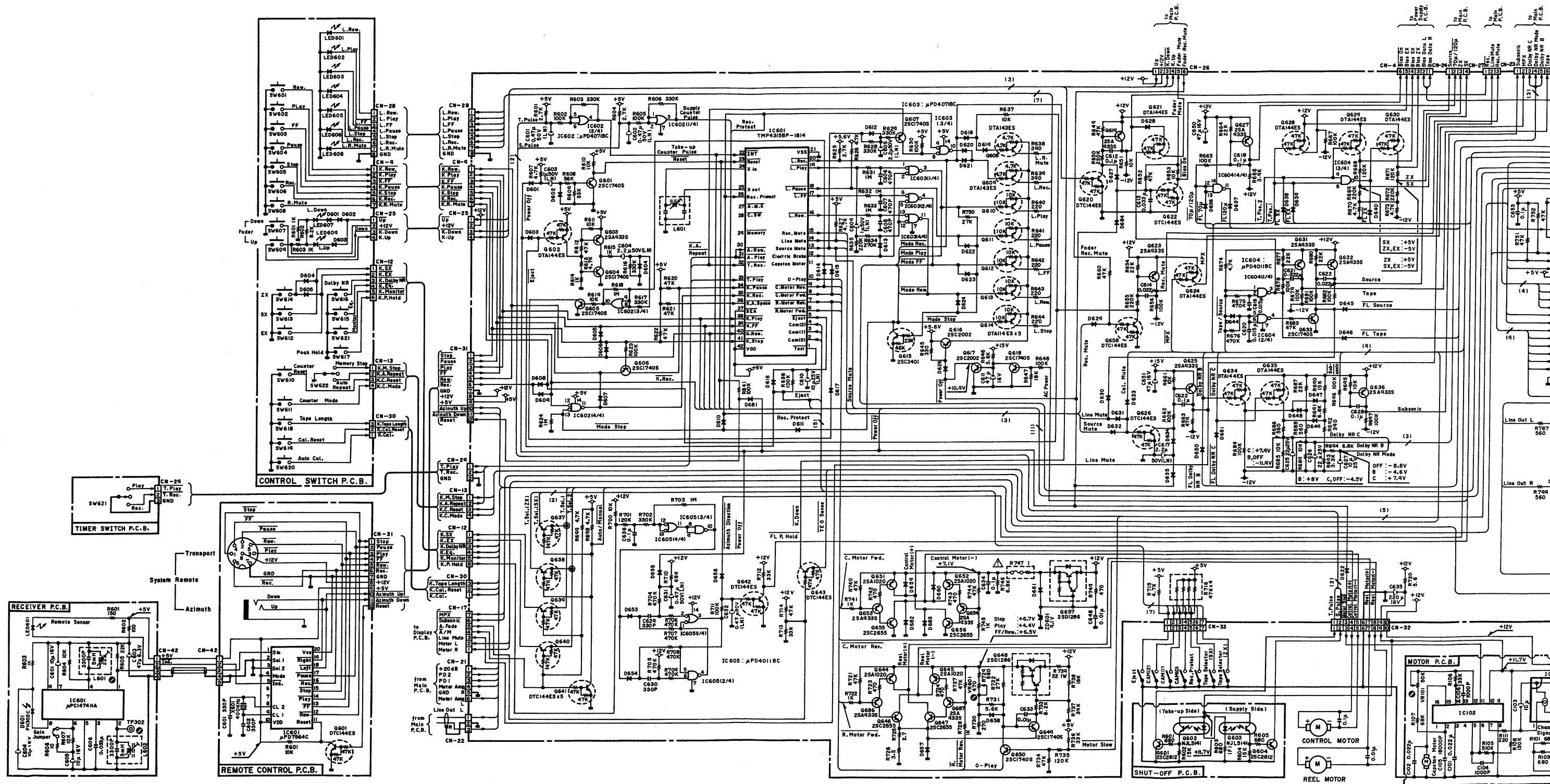

- Notes: 1. Diode is 1SS53, 1S1555, or 1SS176 unless otherwise specified.
 2. 2SA733, 2SA608SP, 2SA1048 and 2SA1175 are interchangeable with each other.
 3. 2SC945, 2SC536SP, 2SC2458 and 2SC2785 are interchangeable with each other.

Fig. 8.2.3

9. WIRING DIAGRAM

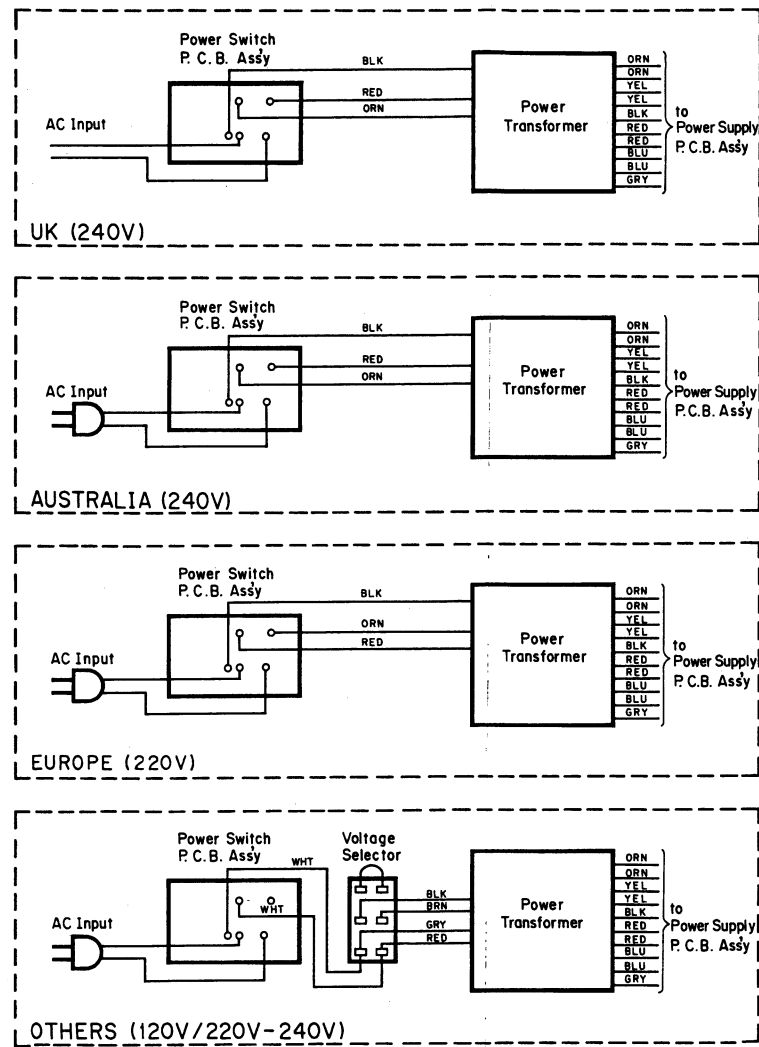

Notes: 1. Table of wire colors

BRN - Brown	BLU - Blue
RED - Red	VIO - Violet
ORN - Orange	GRY - Gray
YEL - Yellow	WHT - White
GRN - Green	BLK - Black

2. Component side view of the P.C.B. is illustrated unless otherwise specified.
 3. Wire tube color is shown in ().

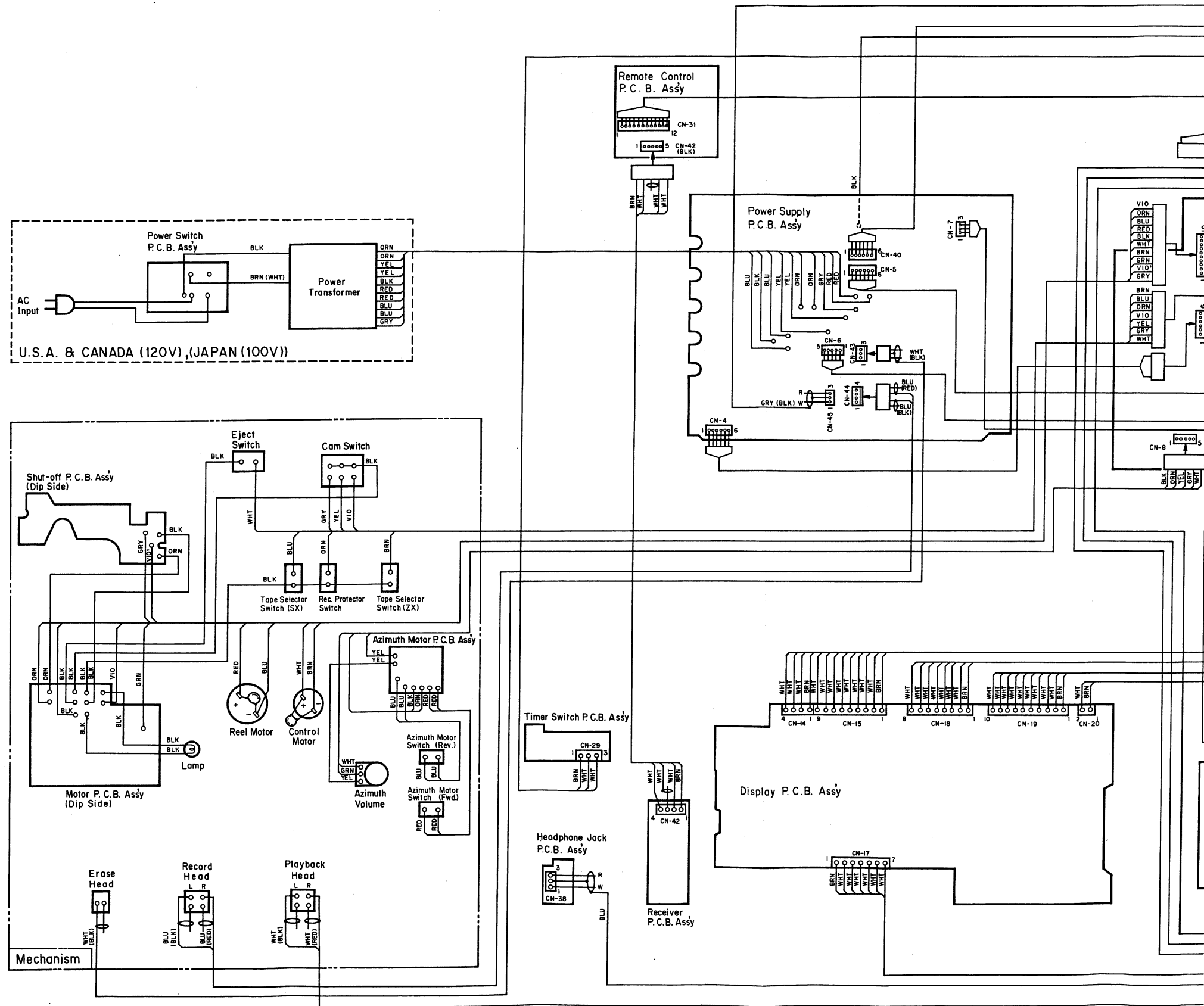

Fig. 9

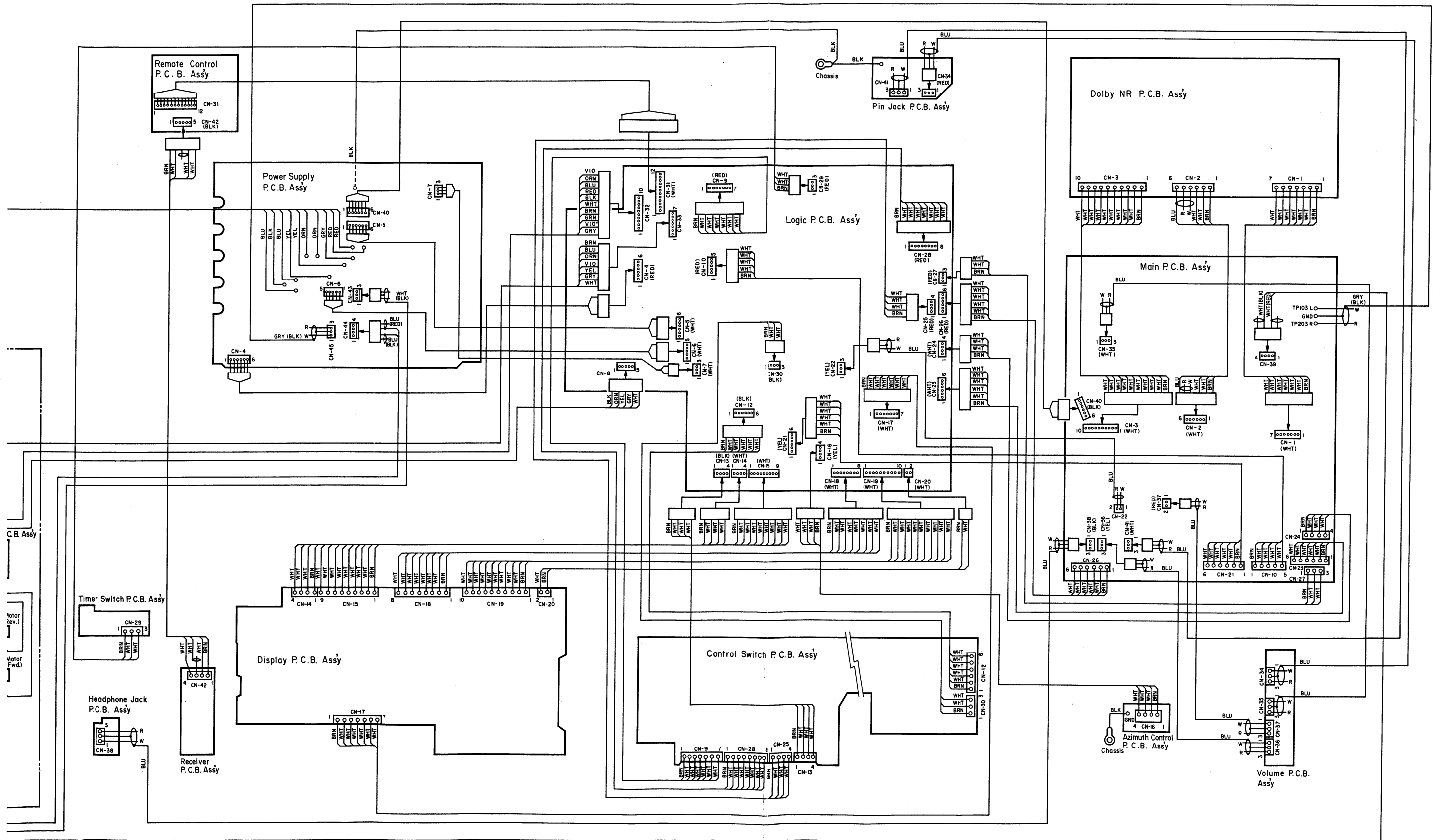

Fig. 9

10. BLOCK DIAGRAMS

10.1. Amplifier Section

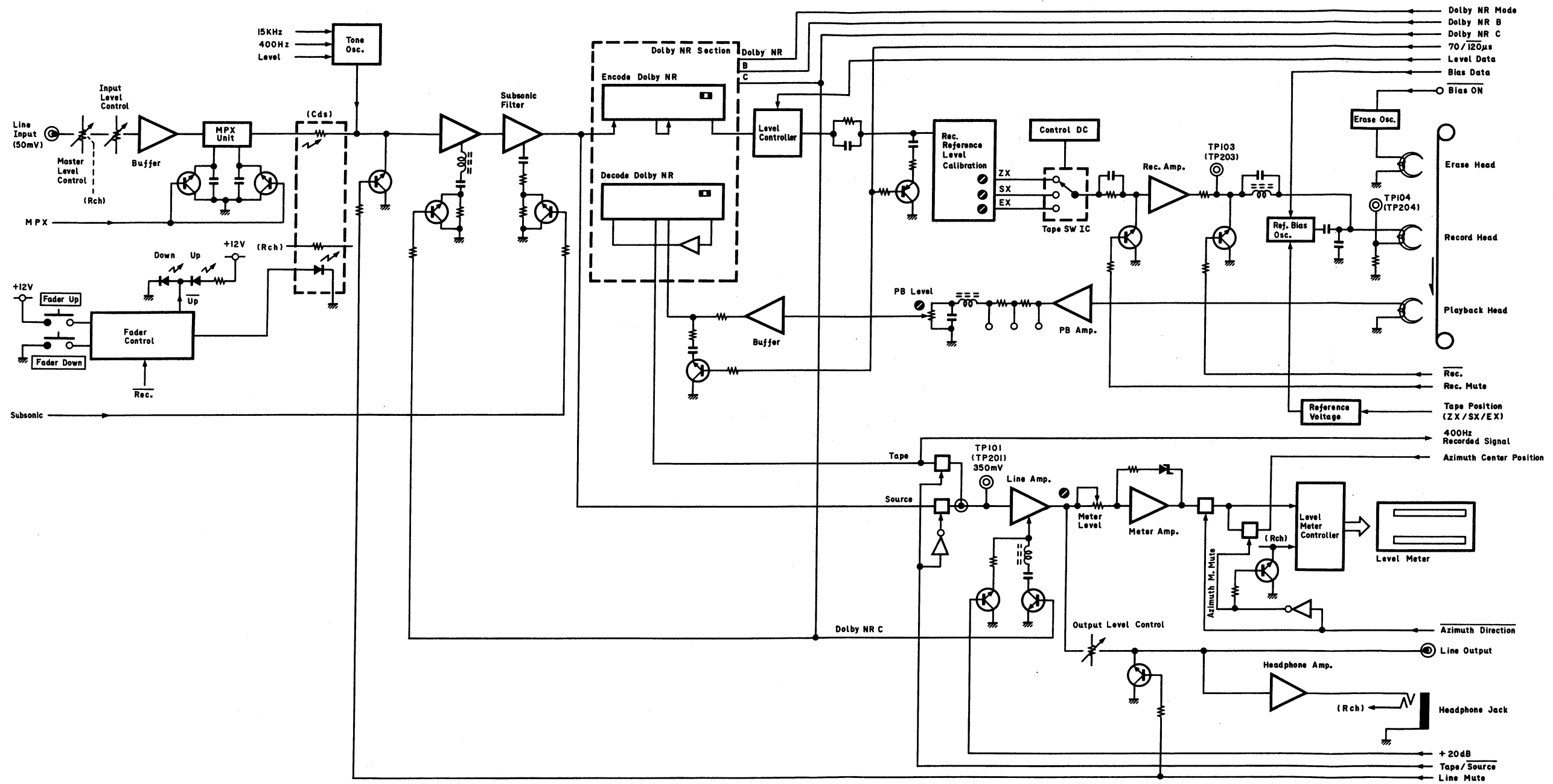

Fig. 10.1

10.2. Mechanism Control Section

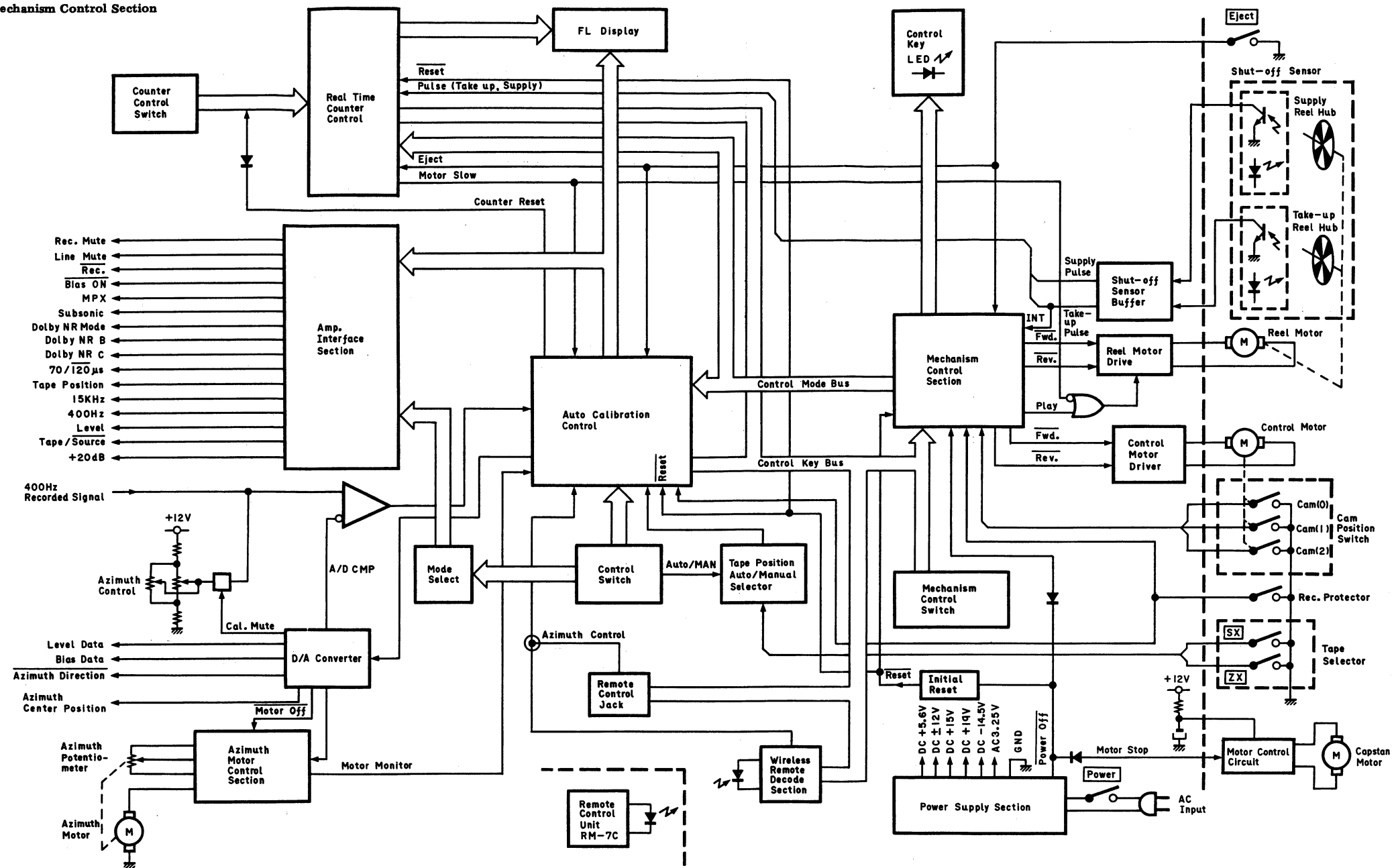

Fig. 10.2

11. TIMING CHART AND EQ. AMP. FREQUENCY RESPONSE

11.1. Eq. Amp. Frequency Response
(1) Playback Frequency Response

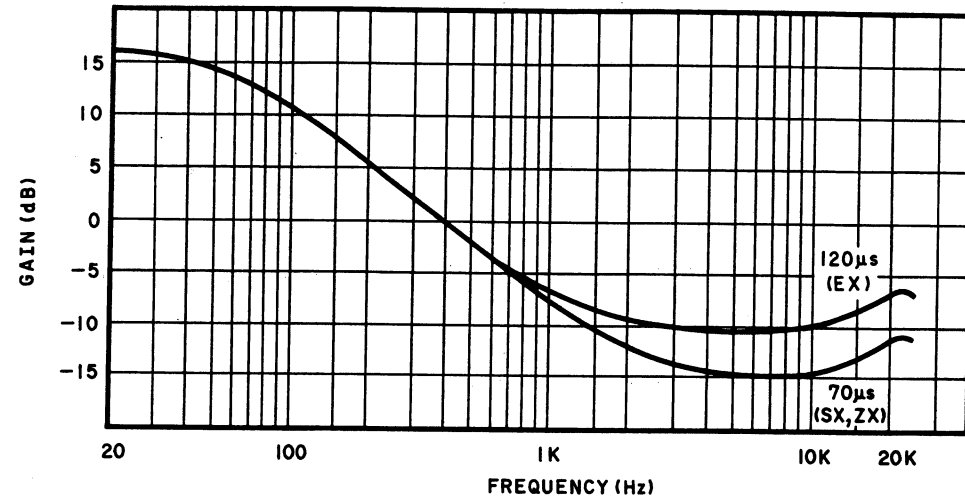

Fig. 11.1.1

(2) Record Current Frequency Response

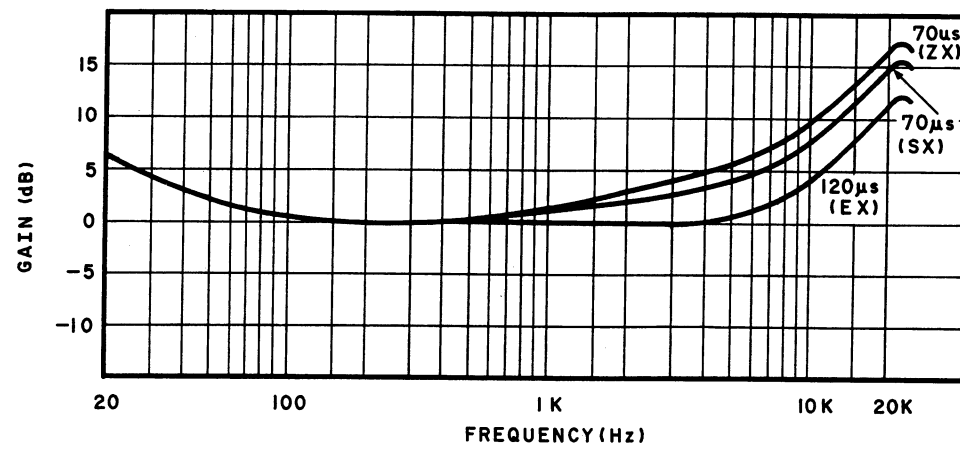

Fig. 11.1.2

11.2. Timing Chart
(1) Overall Timing Chart

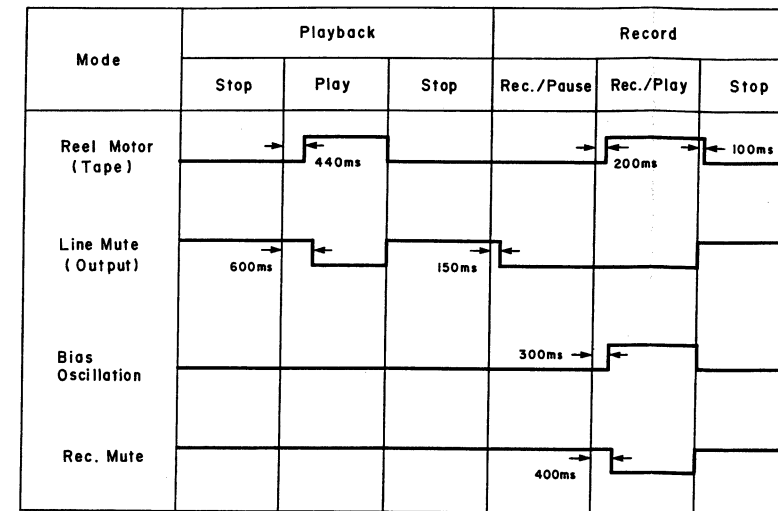

Fig. 11.2.1

(2) Mechanism Control Timing Chart

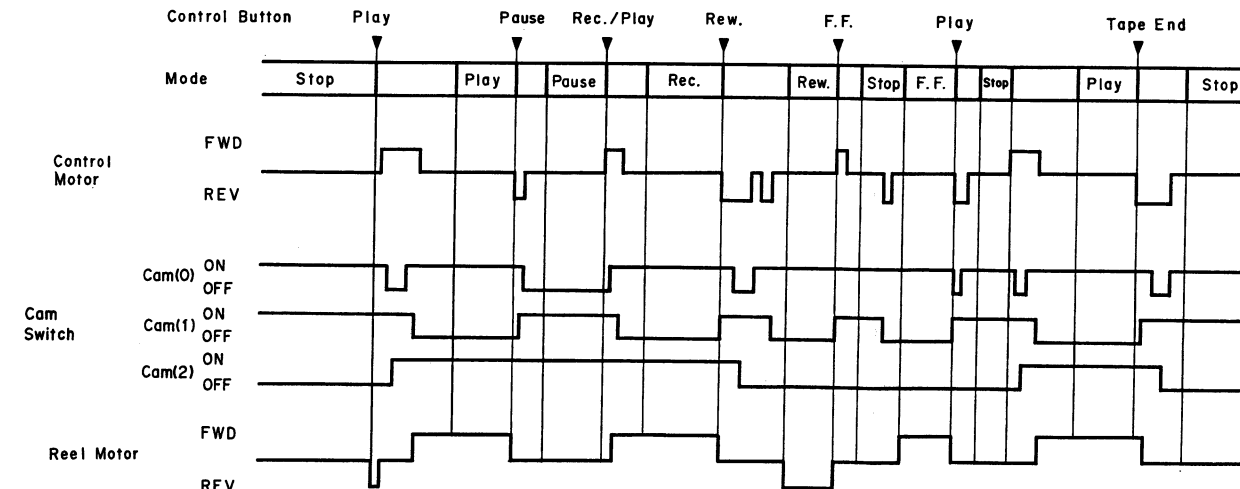

Fig. 11.2.2

12. REMOTE CONTROL UNIT (RM-7C)

12.1. Mechanism Ass'y and Parts List

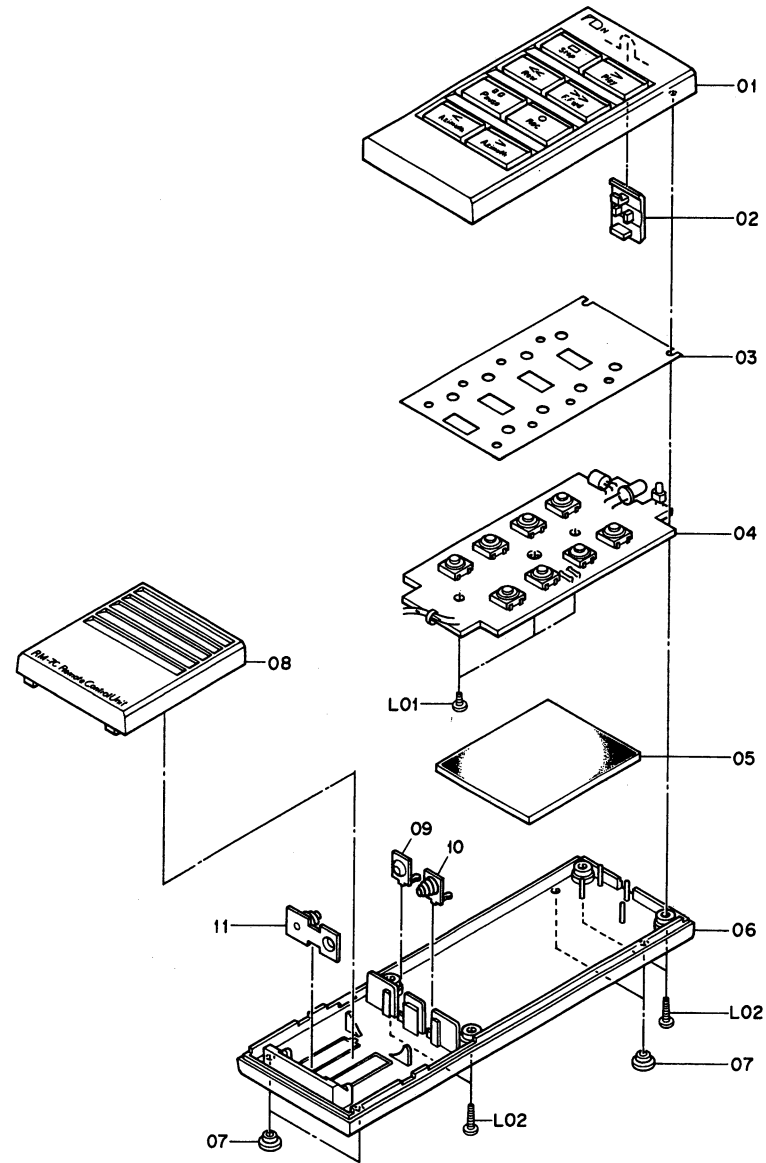

Fig. 12.1

Schematic Ref. No.	Part No.	Description	Qty
	HA04956A	Remote Control Unit (RM-7C) Serial No.: A13001001 -	1
01	OH04785A	Upper Case	1
02	OH04499B	Lens	1
03	OJ05124A	P.C.B. Sheet	1
04	BA05944A	Transmitter P.C.B. Ass'y	1
05	OJ04884A	Rubber	1
06	OH04497C	Bottom Case	1
07	OH03920A	Leg	4
08	OH04786A	Battery Case	1
09	OJ04875A	Terminal Plate A	1
10	OJ04876A	Terminal Plate B	1
11	OJ04877A	Terminal Plate C	1
L01	OE00941A	BT 3x5 @ Binding (Black Chromate)	4
L02	OE00948A	BT 3x10 @ Binding (Black Chromate)	4

12.2. Mounting Diagram and Parts List

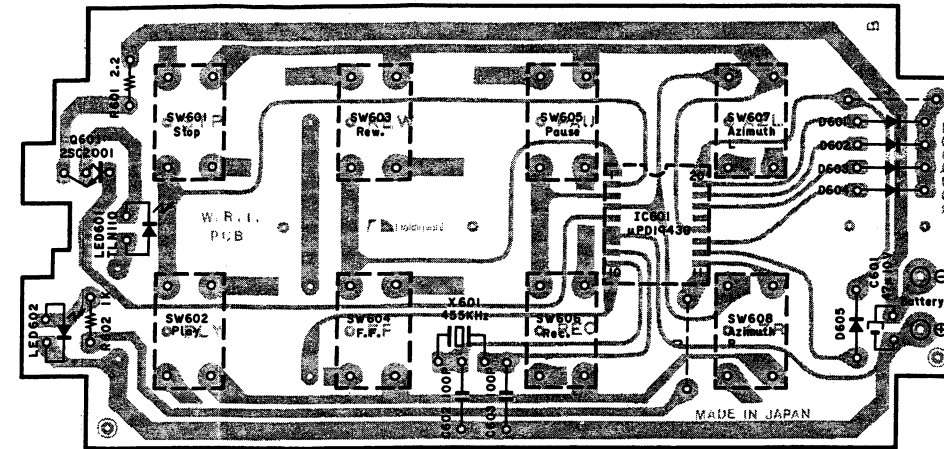

Fig. 12.2

Schematic Ref. No.	Part No.	Description
	BA05944A	Transmitter P.C.B. Ass'y
IC601	OB60297B	Transmitter P.C.B.
Q601	OB11065A	IC μ PD1943G
D601,602	OB10049A	TR 2SC2001 (K)
603,604	OB06181A	SID 1SS53
605		
LED601	OB12224A	Infrared LED TLN110
LED602	OB12218A	LED TLG226 (Green)
X601	OB92001A	Crystal 455kHz
R601	OB09613A	RK 2.2 1/6W J
R602	OB09677A	RK 1K 1/6W J
C601	OB01836A	CE 47 μ 10V
C602,603	OB41079A	CC 100P 50V J
SW601-608	OB70065A	Push Switch (8)
	OB90021A	Band EG-9 (1)

12.3. Schematic Diagram

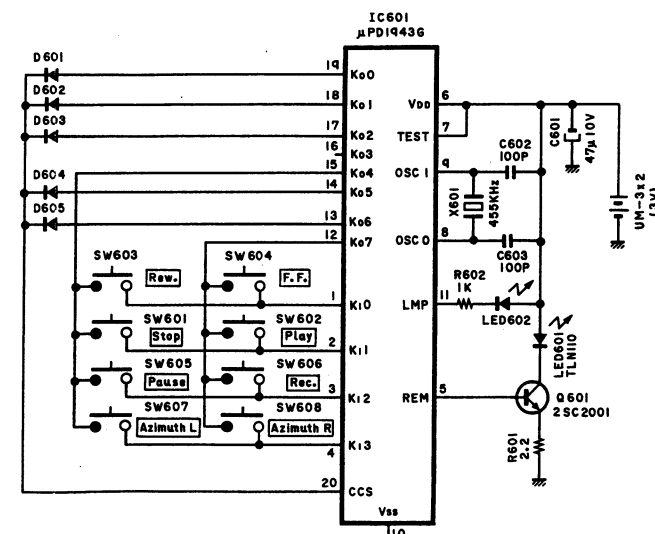

Fig. 12.3

13. SPECIFICATIONS

Main Unit

Track Configuration	4 tracks/2-channel stereo
Heads	3 (erase head x 1, record head x 1, playback head x 1)
Motors	<Tape Transport> FG servo brushless, slotless, coreless DD motor (capstan drive) x 1 DC motor (reel drive) x 1 <Mechanism> DC motor (cam drive) x 1 DC motor (playback head azimuth control) x 1
Power Source	100, 120, 120/220-240, 220 or 240 V AC, 50/60 Hz (According to country of sale)
Power Consumption	55 W max.
Tape Speed	1-7/8 ips. (4.8 cm/sec.) $\pm 0.5\%$
Wow and Flutter	Less than $\pm 0.048\%$ WTD Peak Less than 0.027% WTD RMS
Frequency Response	20 Hz—20,000 Hz ± 2 dB 18 Hz—21,000 Hz ± 3 dB (recording level -20 dB, ZX, SX, EXII tape)
Signal to Noise Ratio	Dolby C-Type NR on <70 μ s, ZX tape> Better than 72 dB (400 Hz, 3% THD, IHF A-WTD RMS) Dolby B-Type NR on <70 μ s, ZX tape> Better than 66 dB (400 Hz, 3% THD, IHF A-WTD RMS)
Total Harmonic Distortion	Less than 0.8% (400 Hz, 0 dB, ZX tape) Less than 1.0% (400 Hz, 0 dB, SX, EXII tape)
Erasure	Better than 60 dB (100 Hz, +10 dB)
Separation	Better than 37 dB (1 kHz, 0 dB)
Crosstalk	Better than 60 dB (1 kHz, 0 dB)
Bias Frequency	105 kHz
Input (Line)	50 mV/40 kohms
Output (Line)	1.0 V (400 Hz, 0 dB, output level control at max.) 2.2 kohms
(Headphones)	12 mW into 8 ohms (400 Hz, 0 dB, output level control at max.)
Fast-Wind Time	Approx. 80 seconds (with C-60 cassette)
Dimensions	435 (W) x 135 (H) x 306 (D) mm 17-1/8 (W) x 5-5/16 (H) x 12 (D) inches
Approximate Weight	9.0 kg 19 lbs., 13 oz.

Remote Control Unit RM-7C

System	Infrared pulse system
Power Supply	DC 3 V (1.5 V x 2)
Dimensions	57 (W) x 175 (H) x 19 (D) mm 2-1/4 (W) x 6-7/8 (H) x 3/4 (D) inches
Approximate Weight	140 g 5 oz.

- Specifications and design are subject to change for further improvement without notice.
- Noise Reduction System manufactured under license from Dolby Laboratories Licensing Corporation.
- The word "DOLBY" and the Double-D-Symbol are trademarks of Dolby Laboratories Licensing Corporation.

Service Manual

Nakamichi CR-7, CR-7A, CR-7E

Nakamichi Corporation

Tokyo Office
Shinjuku Daiichi Seimei Bldg.
2-7-1 Nishishinjuku, Tokyo
Phone (03) 342-4461
Telex : 2324721 (NAKAM J)

Nakamichi U.S.A. Corporation

19701 South Vermont Avenue
Torrance, California 90502
Phone : (213) 538-8150

Nakamichi GmbH

Stephanienstrasse 6, 4000 Düsseldorf 1
Phone : (0211) 359036

O-860220A