

SUB ASSEMBLY MECHANISM/PARTS LIST

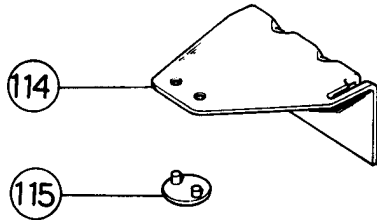

28 CA-3194 FLYWHEEL HOLDER ASS'Y. B

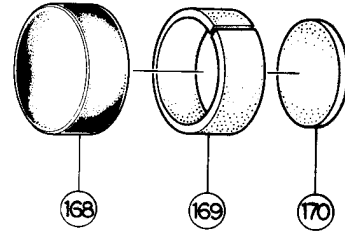

68 CA-3187 MOTOR COVER ASS'Y.

Schematic Ref. No.	Part No.	Description	Schematic Ref. No.	Part No.	Description
4	CA-3208	Auto Shut-off Ass'y.		C-3506	EH Stud
69	C-5497	Tape Counter		C-3732	Head Base B
70	B-7586	Auto Shut Off PC Board		C-3693	Mute Switch Pin
71	C-3763	Read Switch Holder	14	CA-3171	Mechanism Bracket R Ass'y
167	B-3803	Read Switch	95	C-3790	Lid Stopper
226	E-176	Nut 2m/m	96	B-7051	Memory Switch
228	B-185	Screw M2x6 Cylinder Head	99	CA-3223	SS Mechanism Bracket L Sub Ass'y
229	E-149	Washer 2.3m/m Steel	209	E-166	Screw M2x4 Cylinder Head
230	E-37	Earth Lug B-5	214	E-25	Washer 2m/m Steel
240	E-612	Screw M3x6 Philips Pan Head	99	CA-3223	SS Mechanism Bracket L Sub Ass'y.
7	CA-3192	Reel Hub Ass'y (Supply)		C-3737	SS Mechanism Bracket L
72	C-3785	Sprocket B		C-3739	Well Shaft B
73	C-3786	Torque Plate		C-3740	Lid Shaft
74	C-3521	Thrust Bearing	24	CA-3172	Mechanism Bracket R Ass'y
75	C-3520	Reel Hub Spring	95	C-3790	Lid Stopper
76	C-3787	Pulley G	97	C-3764	Well Stopper Rubber
77	C-3522	Reel Hub Ring	98	CA3224	SS Mechanism Bracket R Sub Ass'y
78	C-3519	Reel Hub Felt	100	B-3671	Board Stopper B
79	C-3516	Pulley C	98	CA-3224	SS Mechanism Bracket R Sub Ass'y
20	CA-3193	Reel Hub Ass'y (Take up)		C-3738	SS Mechanism Bracket R
72	C-3785	Sprocket B		C-3739	Well Shaft B
73	C-3786	Torque Plate		C-3740	Lid Shaft
74	C-3521	Thrust Bearing	53	CA-3164	Motor Governor Ass'y (JA)
75	C-3320	Reel Hub Spring	143	C-3806	Governor Insulation Fiber B
76	C-3787	Pulley G	144	B-3922	Governor Heat Sink
77	C-3522	Reel Hub Ring	145	B-7505A	Governor PC Board JA
78	C-3519	Reel Hub Felt	235	E-30	Washer 3 m/m Steel
80	C-3689	Pulley F	236	E-507	Nut 3 m/m
12	CA-3156	Head Base Ass'y	237	E-521	Screw M3x8 Philips Pan Head
81	CA-3159	Pressure Roller Ass'y B	55	CA-3163	Motor Ass'y (JA)
82	C-3758	Pressure Roller Spring B	146	J-3221	Motor Bracket C
83	C-3691	Cassette Retainer Spring R	147	C-3770	Motor Pulley JA
84	C-3588	Azimuth Adjust Rubber	148	B-1905	Ceramic Capacitor 0.02μ 50V
85	C-3692	Base Angle	149	C-3769	Motor J
86	CA-3177	Head Base Sub Ass'y.	150	T-4025	Ceramic Capacitor 0.001μ 50V
89	C-3591	Cord Holder	209	E-166	Screw M2x4 Cylinder Head
90	CA-3170	Erase Head Ass'y (E-50)	214	E-25	Washer 2 m/m Spring
91	CA-3207	REC/Play Head Ass'y (RP-52)	238	E-114	Screw M2x3
92	C-3690	Cassette Retainer Spring L	239	E-224	Screw M2x3
93	C-3767	Base Stopper Rubber	28	CA3194	Flywheel Holder Ass'y B
209	E-166	Screw M2x4 Cylinder Head	114	C-3797	Flywheel Holder B
212	E-218	Scres M2x10 Cylinder Head	115	C-3804	Ball Plate B
214	C-25	Washer 2m/m Spring	68	CA-3187	Motor Cover Ass'y
228	C-185	Screw M2x6 Cylinder Head	168	C-3796	Motor Cap
229	C-149	Washer 2.3 m/m Steel	169	C-3794	Motor Cover A
231	C-42	E Ring E-1.5	170	C-3795	Motor Cover B
232	C-2	Screw M2x3 Cylinder Head			
233	C-120	Screw M2.6x3 Philips Pan Head			
81	CA-3159	Pressure Roller Ass'y B			
	C-3174	Washer 2.1 m/m Mylar			
	C-3733	Pressure Roller B			
	C-3508	Roller Shaft			
	C-3734	Pressure Roller Arm C			
86	CA-3177	Head Base Sub Ass'y			
	C-3510	Pressure Roller Arm Shaft			
	C-3505	RH Stud			

EXPLODED VIEW OF TRANSPORT MECHANISM

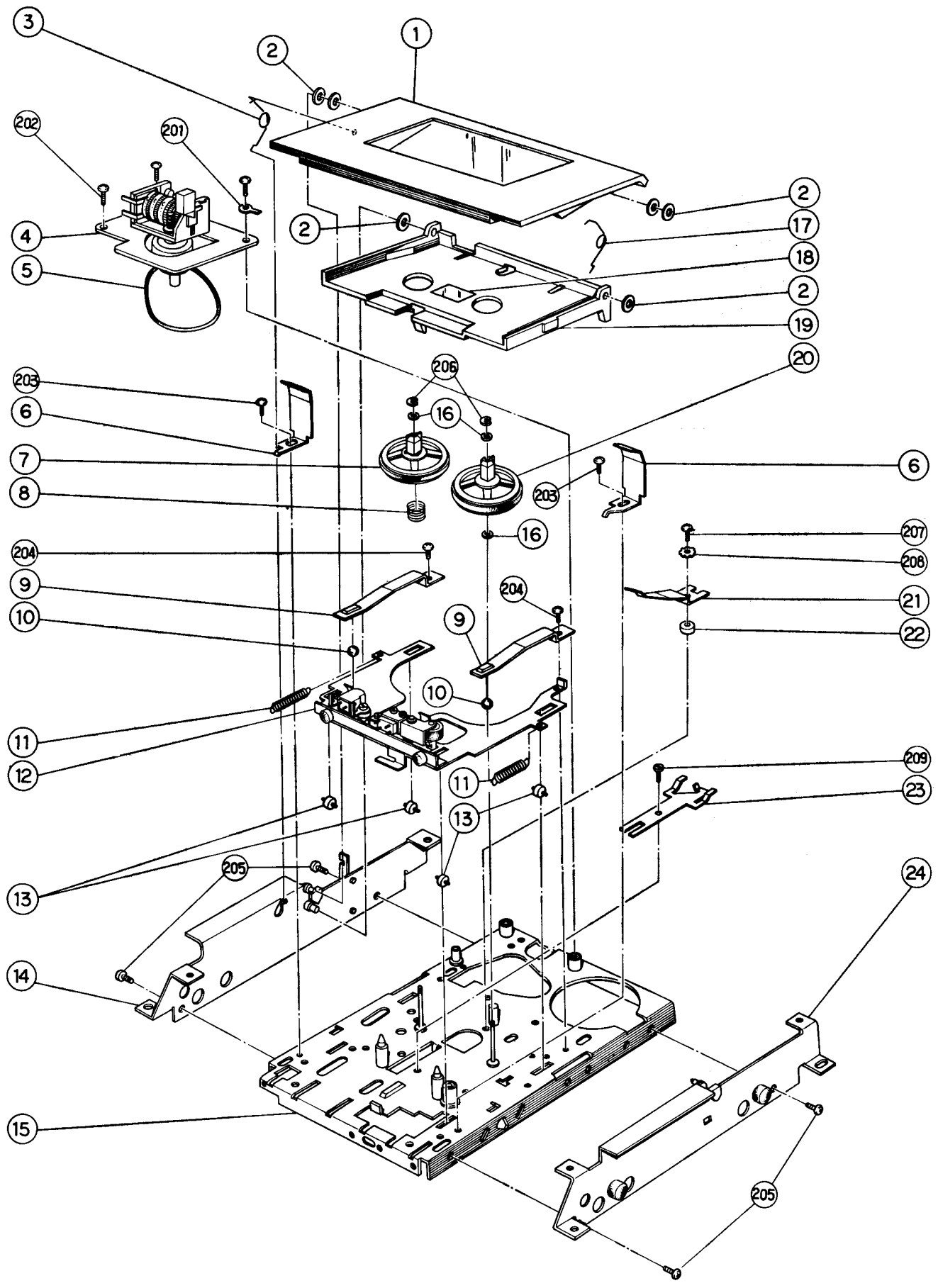

PARTS LIST—TRANSPORT

Schematic Ref. No.	Part No.	Description	Schematic Ref. No.	Part No.	Description
1	C-3736	Cassette Lid			
2	E-254	Washer 3.1 m/m Plastics			
3	C-3759	SS Lid Spring L			
4	CA-3208	Auto Shut off Ass'y			
5	C-3651	Counter Belt E			
6	J-3220	Cassette Guide C			
7	CA-3192	Reel Hub Ass'y (Supply)			
8	C-3612	Back Tension Spring			
9	C-3513	Ball Retainer Spring			
10	C-3595	3 m/m Steel Ball			
11	C-3694	Base Return Spring			
12	CA-3156	Head Base Ass'y			
13	C-3504	Head Base Guide Roller			
14	CA-3171	Mechanism Bracket L Ass'y			
15	CA-3154	Mechanism Chassis Ass'y B			
16	C-3613	Washer 1.6 m/m Plastics			
17	C-3760	SS Lid Spring R			
18	M-3167	Silver Seal B			
19	C-3699	Cassette Well			
20	CA-3193	Reel Hub Ass'y (Take-up)			
21	C-3705	Cassette Well Spring B			
22	C-3706	Cassette Well Spring Stud			
23	CA-3140	Brake Ass'y			
24	CA-3172	Mechanism Bracket R Ass'y			
201	E-130	Earth Lug 2.6 m/m			
202	E-219	Screw M2.6x5 Philips Pan Head			
203	E-226	Screw M2.6x4 Philips Pan Head			
204	E-228	Screw M2.6x6 (FT) Philips Pan Head			
205	E-502	Screw M3x5 Philips Pan Head			
206	E-165	E Ring E-1.2			
207	E-231	Screw M2.6x8 (7.7) Philips Pan Head			
208	E-233	Washer 2.6 m/m Toothed Lock			
209	E-166	Screw m2x4 Cylinder Head			
(15)	CA-3154	Mechanism Sub Ass'y.			
	C-3113	Counter Stud			
	C-3817	Counter Stud B			
	C-3514	Reel Hub Shaft			
	C-3515	Reel Hub Shaft			
	C-3502	Reference Pin			
	C-3728	Mechanism Chassis B			
	C-3512	Cassette Stud			
	C-3525	Capstan Sleeve Ass'y			
	C-3713	Motor Stud B			
	C-3731	Pause Lock Plate Shaft			
	C-3729	Slide Guide Pin A			
	C-3730	Slide Guide Pin B			
	C-3531	Drive Arm Shaft			

EXPLODED VIEW OF TRANSPORT MECHANISM

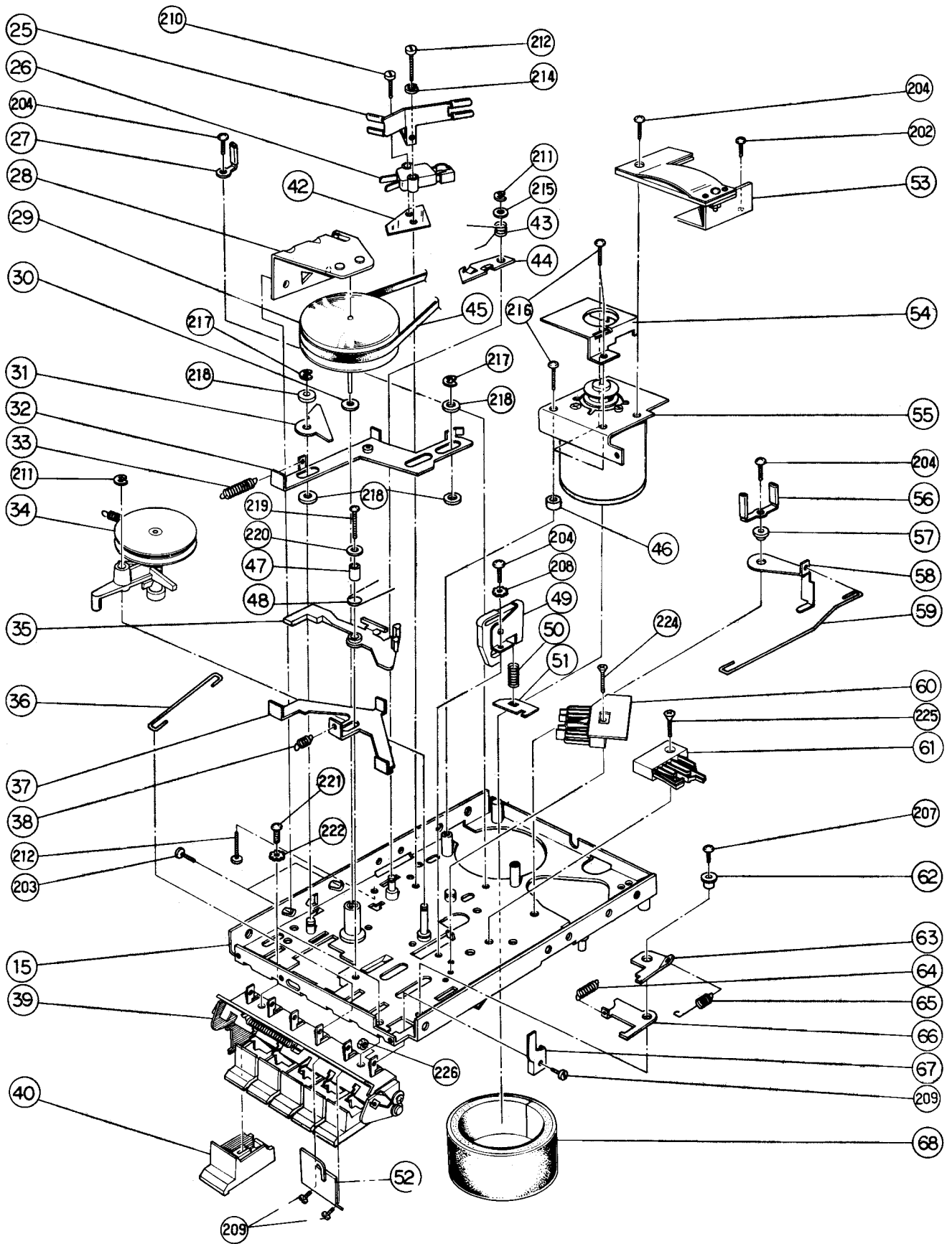

PARTS LIST—TRANSPORT

Schematic Ref. No.	Part No.	Description	Schematic Ref. No.	Part No.	Description
25	C-3799	Belt Guide		C-3558	Cam Spring
26	C-3743	Pause Switch		C-3554	Button Bracket
27	C-3591	Cord Holder		C-3555	Button Cam
28	CA-3194	Flywheel Holder Ass'y B		C-3735	Cam Spring B
29	CA-3115	Flywheel Ass'y		CA-3168	Lock Plate Ass'y
30	C-3174	Washer 2.1m/m Plastics		C-3783	Stud B
31	C-3746	Pause Bar		E-166	Screw M2x4 Cylinder Head
32	CA-3167	Slide Plate Ass'y		E-181	E-Ring E-3
33	C-3748	Slide Plate Spring		E-184	Screw M2.6x6 Flat Head
34	CA-3150	Idler Pulley Ass'y		E-30	Washer 3m/m Steel
35	C-3646	FRP Lever B			
36	C-3553	Eject Linkage Wire			
37	C-3647	See-Saw Arm	(49)	CA-3118	Eject Arm Ass'y.
38	C-3649	See-Saw Arm Spring		C-3551	Eject Pin
39	CA-3174C	Button Bracket Ass'y		C-3667	Eject Lever B
40	C-3752	Deck Button (SS)		C-3550	Eject Bracket
42	C-3800	Pause Switch Mylar			
43	C-3747	Lock Lever Spring			
44	C-3084	Pause Lock Lever			
45	C-3668	Driving Belt			
46	C-3805	Motor Stud Color	(60)	CA-3169	Start Switch Ass'y.
47	C-3648	See-Saw Arm Pipe		C-3643	Start Switch Board
48	C-3650	Lever Spring		C-3781	Mother Spring B
49	CA-3118	Eject Arm Ass'y		C-3577	Start Switch A
50	C-3552	Eject Spring		C-3578	Start Switch B
51	C-3644	Spring Stopper		C-3777	Start Switch C
52	C-3823	Solenoid Connection Plate C		C-3576	Switch Case
53	CA-3164	Motor Governor Ass'y JA		C-3780	Start Switch F
54	C-3814	Motor Shield		C-3779	Start Switch E
55	CA-3123	Motor Ass'y		C-3778	Start Switch D
56	B-3067	Bind Holder			
57	C-3546	Record Lock Shaft			
58	C-3703	Record Censer B			
59	C-3704	Record Censer Linkage B	(61)	CA-3141	Mute Switch Ass'y.
60	CA-3169	Start Switch Ass'y		C-3698	Mute Switch Spring Stopper
61	CA-3141	Mute Switch Ass'y		C-3575	Mute Switch Spring E
62	C-3775	Base Cam Shaft		C-3574	Mute Switch Spring D
63	C-3652	Record Lock B		C-3696	Mute Switch Spring L
64	C-3774	Base Cam Spring		C-3697	Mute Switch Spring R
65	C-3791	Record Lock Spring B		C-3695	Mute Switch Holder B
66	C-3773	Base Cam		C-3572	Mute Switch Spring B
67	C-3727	Record Cam Ring			
68	CA-3187	Motor Cover Ass'y			
210	E-4	Screw M2x8 Cylinder Head			
211	E-222	E Ring E-2	(135)	CA-3168	Lock Plate Ass'y.
212	E-218	Screw M2x10 Cylinder Head		C-3776	Lock Plate C
214	E-25	Washer 2m/m Spring		C-3610	Lock Spring B
215	E-253	Washer 3.3m/m Steel		C-3611	Lock Plate B Guide
216	E-220	Screw M2.6x8 Philips Pan Head		C-3607	Lock Plate B
217	E-181	E-Ring E-3			
218	E-31	Washer 4m/m Steel			
219	E-229	Screw M2.6x10 Philips Pan H/Fad			
220	E-142	Washer 2.6m/m Steel			
221	E-509	Screw M3x6 Philips Pan Head			
222	E-172	Washer 3m/m Toothed Lock			
224	E-223	Screw M2x10 Flat Head			
225	E-8	Screw M2.6x8 Flat Head			
226	E-176	Nut 2m/m			
(32)	CA-3167	Slide Plate Ass'y.			
	C-3086	Pause Lock Pin			
	C-3744	Pause Slide Plate			
(34)	CA-3150	Idler Pulley Ass'y			
	C-3717	Idler Pulley B			
	C-3718	Earth Spring C			
	C-3715	Idler Pulley Arm B			
	C-3623	Drive Pulley			
	C-3613	Washer 1.6m/m Plastic			
	C-3716	Idler Pulley Metal			
	C-3719	Earth Washer			
	C-3534	Drive Pulley Shaft			
(39)	CA-3174C	Push Button Ass'y.			
	C-3609	Lock Spring A			
	C-3677	Lock Plate Stopper			
	C-3560	Button Shaft			

EXPLODED VIEW OF CABINET

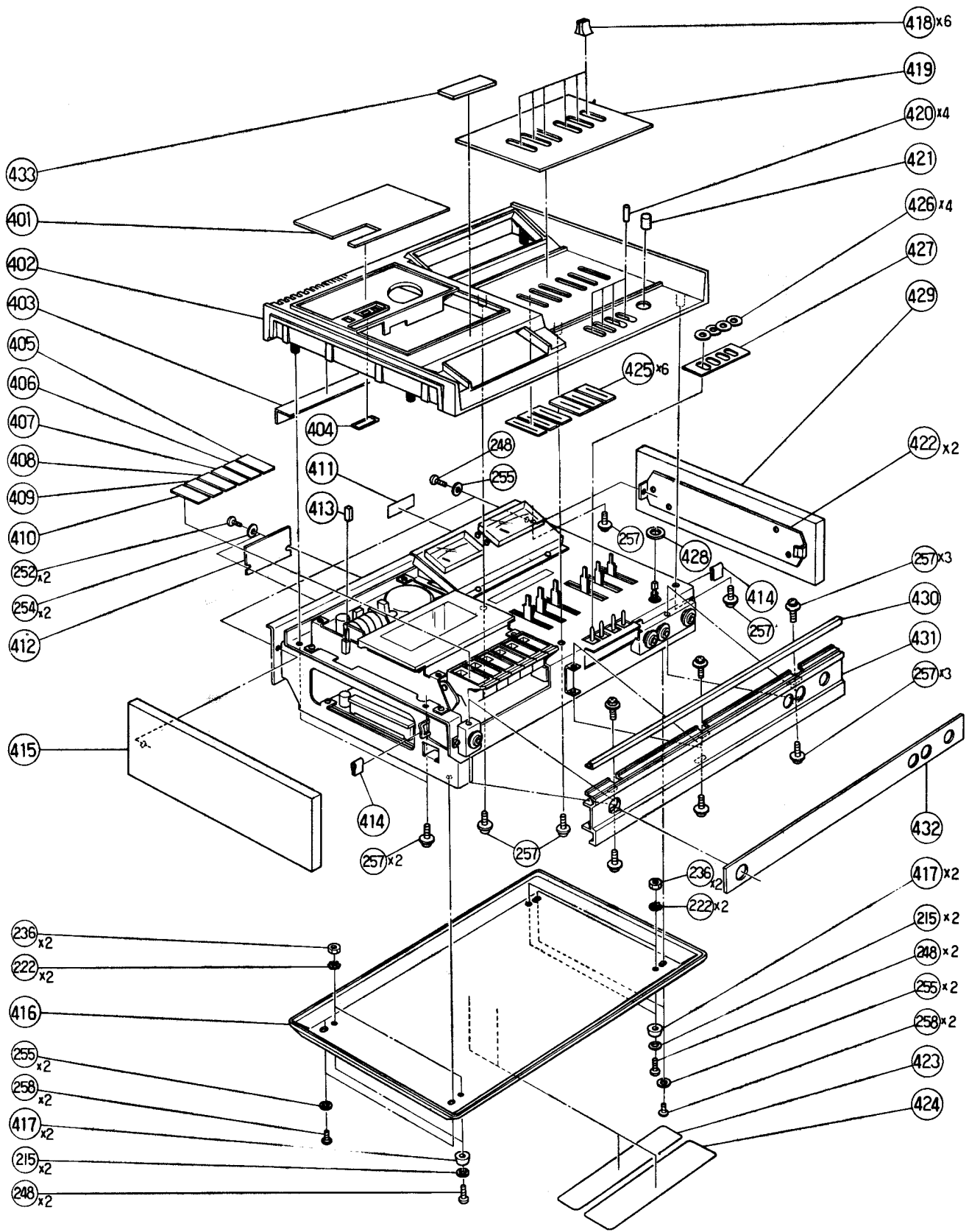

PARTS LIST—CABINET

Schematic Ref. No.	Part No.	Description	Schematic Ref. No.	Part No.	Description
— HA-3595 Top Cover Ass'y (NR) —					
401	M-3488	Counter Pannel (DT-500)			
402	A-3210	Top Cover			
	A-3194	Stud e			
	A-3195	Stud g			
	A-3196	Stud h			
403	A-3197	Top Cover Hemilor			
404	H-3099	Counter Lens V			
419	M-3489	Control Name Plate (DT-500)			
425	H-3294	Volume Shade			
433	M-3505	FG Badge (NR-35)			
— HA-3591 Bottom Cover Ass'y —					
416	A-3071	Bottom Cover			
417	A-318	Rubber Foot			
423	M-3330	Dolby Level			
424	M-3339	Caution Level			
215	E-253	Washer 3m/m Steel			
222	E-172	Washer 3m/m Toothed Lock			
236	E-507	Nut 3m/m			
248	E-588	Screw M3x8 Philips Pan Head			
— HA-3596 Front Pannel Ass'y —					
430	A-3193	Sash GM			
431	H-3348	Front Pannel (DT-500)			
432	M-3490	Front Name Plate (DT-500)			
405	M-3496	Pause Name Plate			
406	M-3495	FF Name Plate			
407	M-3494	PLAY Name Plate			
408	M-3493	STOP Name Plate			
409	M-3492	REW Name Plate			
410	M-3491	REC Name Plate			
412	M-3497	Serial Name Plate (DT-500)			
413	H-3324	Memory Switch Button			
414	A-3032	Side Plate Spring			
415	A-3213	Side Plate L			
418	H-3196	Slide Volume Knob			
420	H-3310	Switch Cap			
421	H-3248	Switch Buttom			
422	A-3065	CN Bracket			
426	H-3338	Switch Shade B			
427	H-3337	Switch Shade A			
428	H-3313	Switch Shade			
429	A-3212	Side Plate R			
248	E-588	Screw M3x8 Philips Pan Head			
252	E-592	Screw M2.6x4 Philips Pan Head			
254	E-651	Washer 2.6m/m Plastic			
255	E-157	Washer 3m/m Plastic			
257	E-607	Screw M3x8 (3A) Philips Pan Head			
258	E-593	Screw M3x6 Philips Pan Head			

EXPLODED VIEW OF CHASSIS

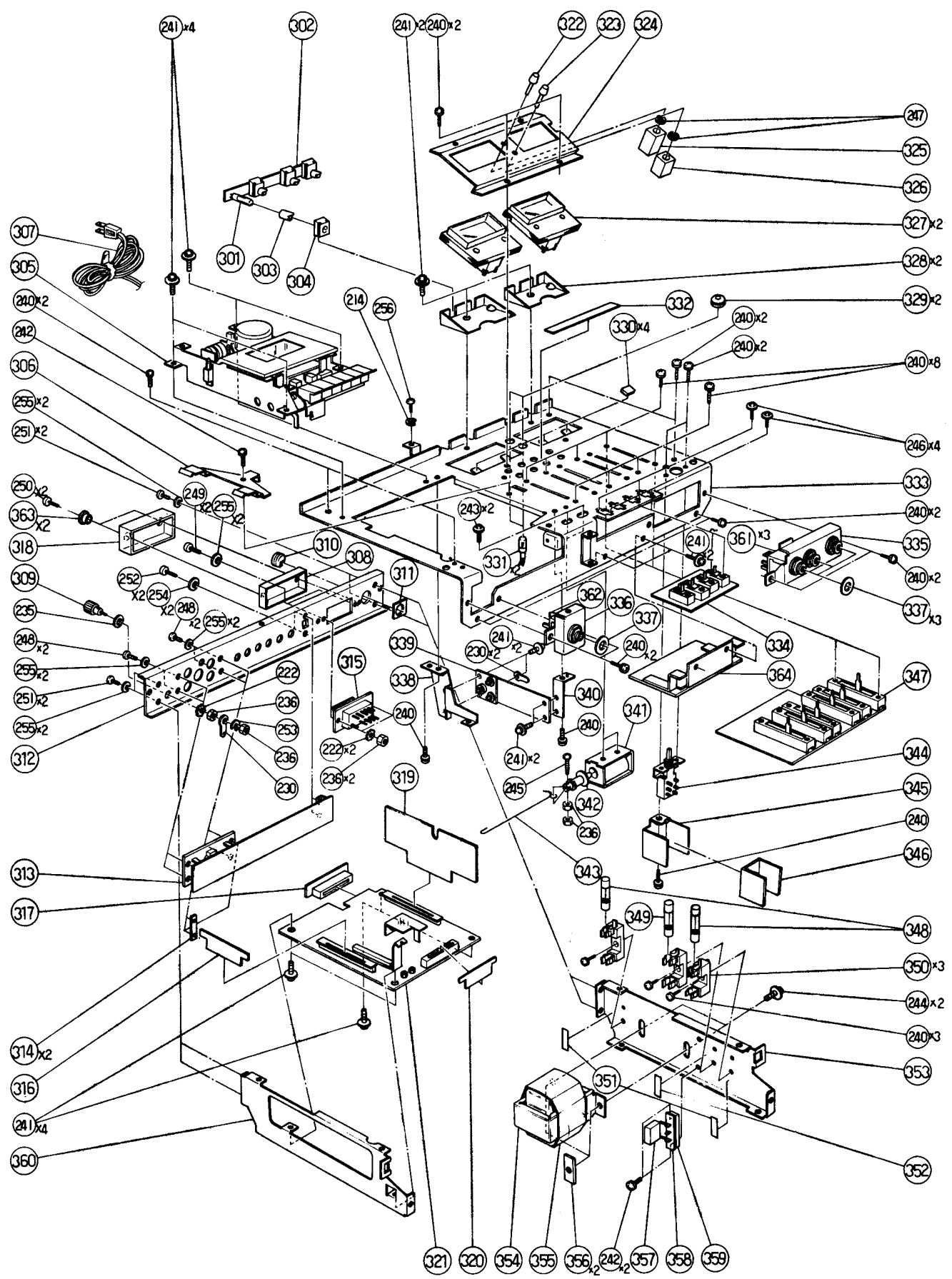

PARTS LIST—CHASSIS

Schematic Ref. No.	Part No.	Description	Schematic Ref. No.	Part No.	Description
301	B-8101	Meter Lamp 6.3V, 0.2A	242	E-510	Screw M3x8 (2A) Philips Pan Head
302	B-7599U	Lamp PC Board	243	E-618	Screw M3x4 (Triple) Philips Pan Head
303	J-3316	Lamp Shield	244	E-643	Screw M4x8 (3A) Philips Pan Head
304	J-3274	Meter Lamp Hold	245	E-514	Screw M3x15 Philips Pan Head
305	CA-3228	Mechanism Ass'y	246	E-259	Screw M2.6x4 (Triple) Philips Pan Head
306	B-3843	Dolby PC Board Holder	247	E-252	Washer 3m/m CS type
307	B-3900U	Power Cord	248	E-588	Screw M3x8 Philips Pan Head
308	H-3335	Voltage Selector Socket Cover	249	E-590	Screw M3x12 Philips Pan Head
309	B-3920	Ground Terminal	251	E-589	Screw M3x6 Philips Pan Head
310	B-8037	Cord Bushing C	252	E-592	Screw M2.6x4 Philips Pan Head
311	A-3154	Cord Spacer	253	E-581	Washer 3m/m Spring
312	J-3323	Rear Panel (DT-500)	254	E-651	Washer 2.6m/m Plastic
313	BA-3660	Record CAL. Board Ass'y	255	E-157	Washer 3m/m Plastic
314	J-3277	Metal Seat Nut	256	E-124	Screw M2x4 Philips Pan Head
315	B-3877	Voltage Selector Socket	257	E-591	Screw M3x20 Philips Pan Head
316	B-1651	14P Plug Board			
317	BA-3694	19P Sub Board Ass'y			
318	H-3334	Voltage Selector Socket Acrylic Cover			
319	BA-3625	Dolby Board Ass'y			
320	B-1798	19P Plug Board			
321	BA-3682	Main Board Ass'y			
322	H-3141	Lamp Cover CN1 (RED)			
323	H-3142	Lamp Cover CN2 (Green)			
324	H-3345	Meter Holder (DT-500)			
325	J-3321	Light Intercepting Pipe GA			
326	J-3322	Light Intercepting Pipe GB			
327	B-8111	Level Meter			
328	J-3315	Reflecting Plate			
329	B-1431	Rubber Bush			
330	B-3939	Meter Cushion			
331	B-3884	Pilot Lamp 12V, 25mA			
332	M-3524	Adj. Indicator Lavel			
333	JA-3254	Main Chassis Ass'y			
334	BA-3657	Switch Sub Board Ass'y			
335	J-3261	Jack Holder			
336	J-3264	Head Phone Holder			
337	J-3236	Jack Cover			
338	J-3267	Main PC Board Holder			
339	BA-3634	D.C. Supply Board Ass'y			
340	J-3340	D.C. Sppply Board Holder			
341	B-8092	Solenoid			
342	B-8099	Solenoid Mylar			
343	J-3273	Solenoid Connection Plate			
344	B-3771	Power Switch			
345	J-3263	Power Switch Cover			
346	B-8110	Shield Plate			
347	BA-3661	Volume Sub Board Ass'y			
348	B-8100	Fuse 250V, 2A			
349	B-8098	Fuse 250V, 315mA			
350	B-8048	Fuse Holder			
351	M-3448	Fuse Lavel 2A			
352	M-3449	Fuse Lavel 315mA			
353	J-3255	Chassis Right			
354	B-6520	Power Trans			
355	J-3051	Trans Shield Plate			
356	C-1162	Metal Seat Nut			
357	B-3873	Spark Killer			
358	B-8030	3P Terminal Insulator			
359	B-8024	3P Terminal Strip			
360	J-3256	Chassis Left			
361	B-3881	Mic Jack			
362	B-3882	Headphone Jack			
363	H-3366	Washer for Voltage Selector Cover			
364	BA-3659	400Hz OSC Board Ass'y			
365	J-3327	Blue Filter			
R146, 246	B-4042	3P Lug Terminal			
R721, 821	B-5566	Carbon Resistor 2.2K ELR $\frac{1}{2}$, J			
909	B-5698	Carbon Resistor 1.5K R $\frac{1}{4}$, J			
C718, 818	T-4027	Ceramic Capacitor 680P, 50V, M			
910					
214	E-25	Washer 2m/m Spring			
222	E-172	Washer 3m/m Toothed Lock			
230	E-37	Earth Lug B-5			
235	E-30	Washer 3m/m Steel			
236	E-507	Nut 3m/m			
240	E-612	Screw M3x6 (2A) Philips Pan Head			
241	E-606	Screw M3x6 (3A) Philips Pan Head			

MECHANISM WIRING DIAGRAM

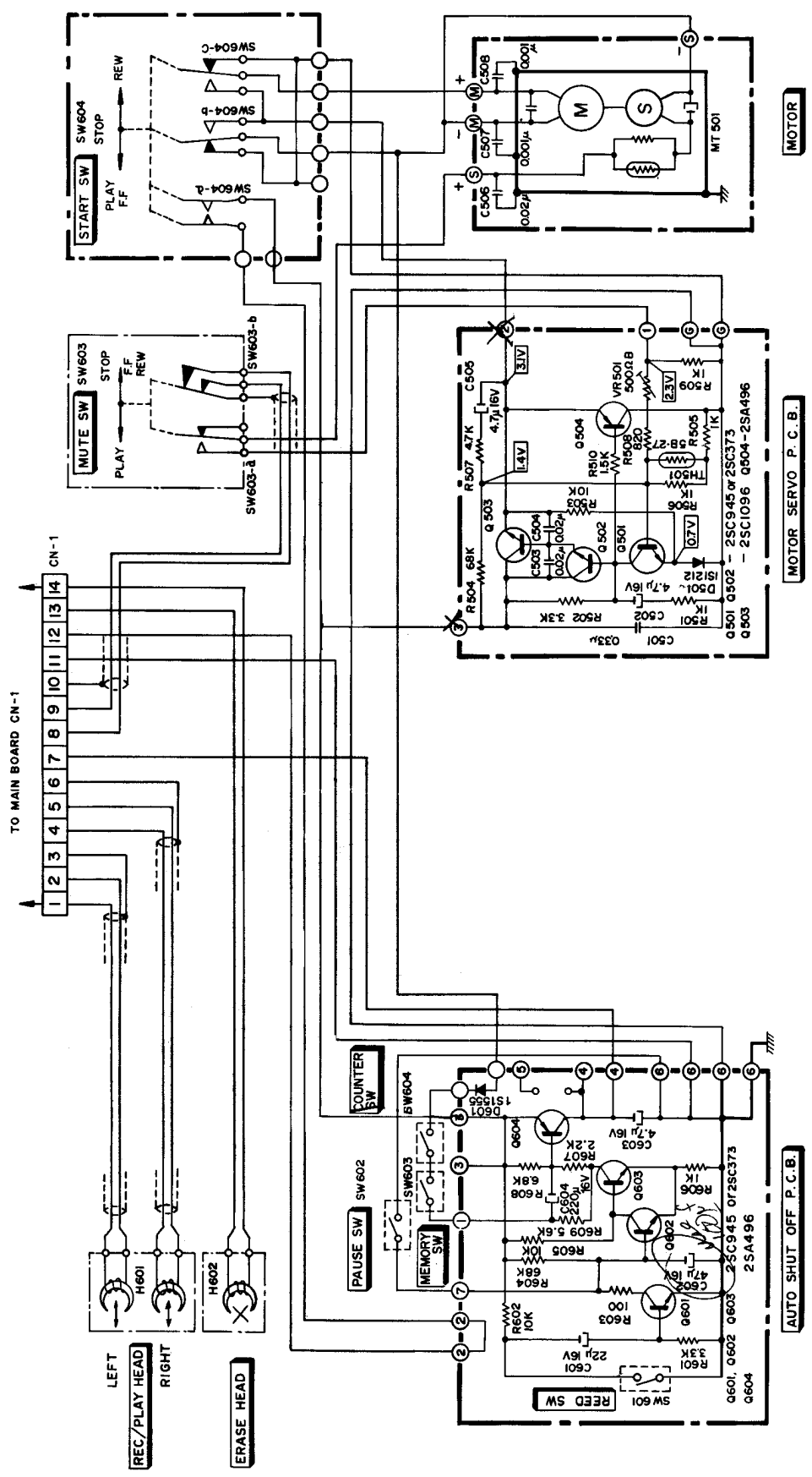

SCHEMATIC DIAGRAM

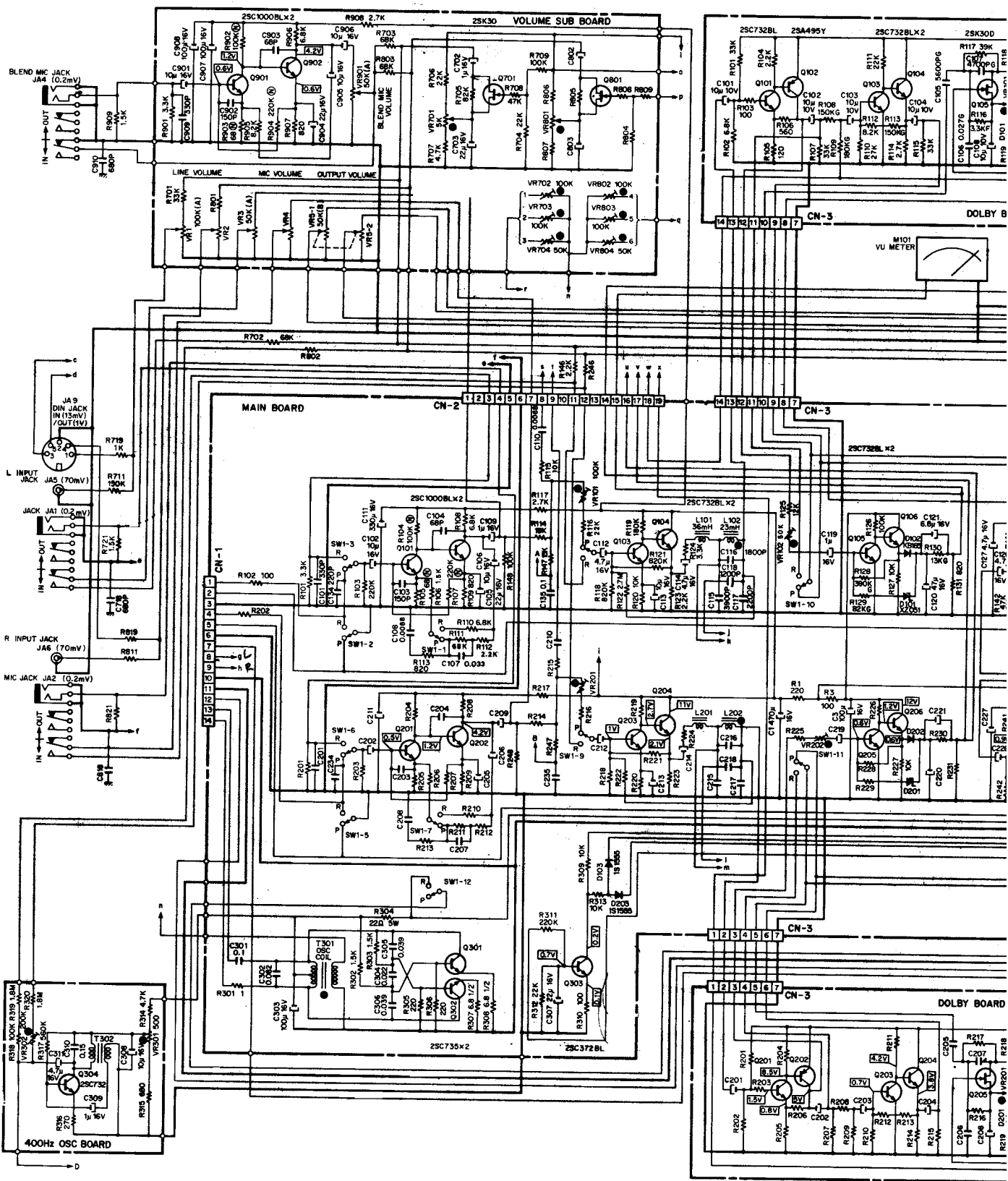

BLOCK DIAGRAM

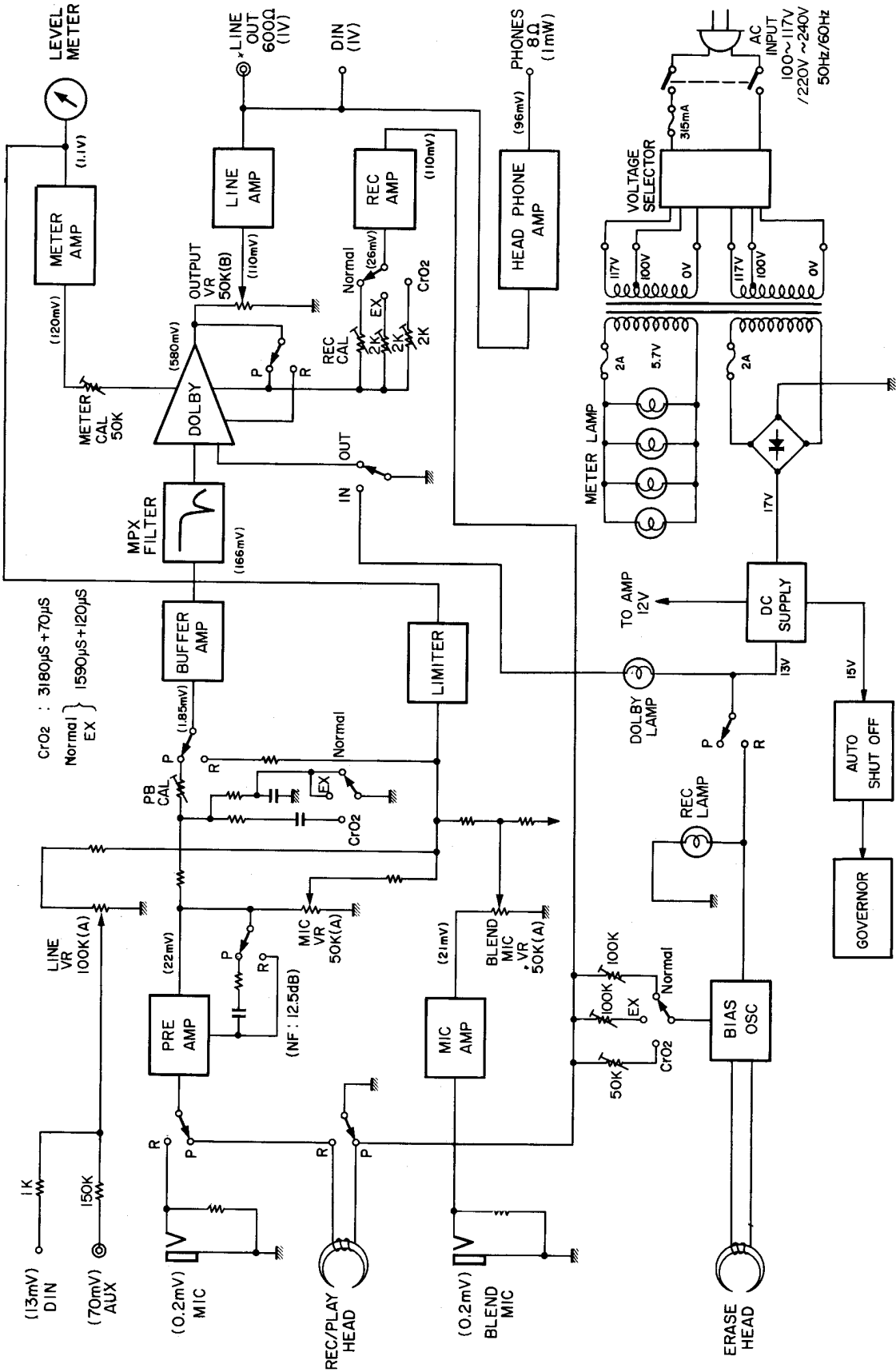

Service Manual

Nakamichi 500

NAKAMICHI RESERACH INC.

1-153 Suzukicho, Kodaira, Tokyo
Phone: (0423) 42-1111
Telex: 2832610 (NAKREI J)
Cable: NAKREI KKB

NAKAMICHI RESEARCH (U.S.A.) INC.

West Coast Office
1101 Colorado Avenue,
Santa Monica, Calif. 90404
Phone: (213) 451-5901
Telex: 65249 (NAKREI SNM)

NAKAMICHI RESEARCH (U.S.A.) INC.

New York Office
220 Westbury Avenue,
Carle Place, N.Y. 11514
Phone: (516) 333-5440
Telex: 144513 (NAKREI CAPL)