



Service Manual

Nakamichi NR-200

Dolby B-C Type Noise Reduction System



NR-200

CONTENTS

1. General	2
2. Removal Procedures	3
2. 1. Side Plates	3
2. 2. Top Cover Ass'y	3
2. 3. Bottom Cover Ass'y	3
2. 4. Front Panel Ass'y	3
2. 5. Front Chassis Ass'y, Volume P.C.B. Ass'y, Indicator Ass'y and Lamp P.C.B. Ass'y	3
2. 6. Main P.C.B. Ass'y and Dolby NR Switch P.C.B. Ass'y	3
2. 7. Power Transformer and Fuse P.C.B. Ass'y	3
2. 8. Power Switch	3
2. 9. Rear Panel Ass'y	3
3. Parts Location for Electrical Adjustment	5
4. Electrical Adjustments and Measurements	6
4. 1. Adjustment and Measurement Instructions	6
4. 2. Dolby NR Circuit Check	7
5. Mounting Diagrams and Parts List	7
5. 1. Indicator P.C.B. Ass'y	7
5. 2. Dolby NR Switch P.C.B. Ass'y	7
5. 3. Lamp P.C.B. Ass'y	8
5. 4. Volume P.C.B. Ass'y	8
5. 5. Fuse P.C.B. Ass'y	8
5. 6. Main P.C.B. Ass'y	9
6. Mechanism Ass'y and Parts List	11
6. 1. Synthesis Mechanism Ass'y	11
6. 2. Front Panel Ass'y (A01)	11
6. 3. Chassis Ass'y (A02)	12
6. 4. Indicator Ass'y (B01)	13
6. 5. Slide Volume Ass'y (B02)	14
6. 6. Rear Panel Ass'y (B03)	15
7. Block Diagram	16
8. Performance Data	17
9. Wiring Diagram	19
10. Schematic Diagram	20
11. Specifications	22

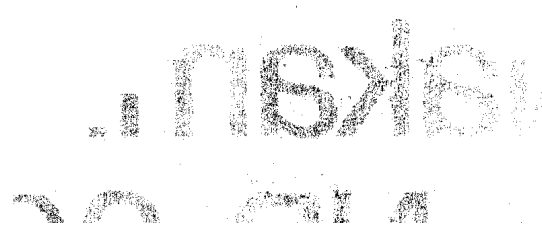

1. GENERAL

1.1. Control Functions

The Nakamichi NR-200 control functions are shown below:

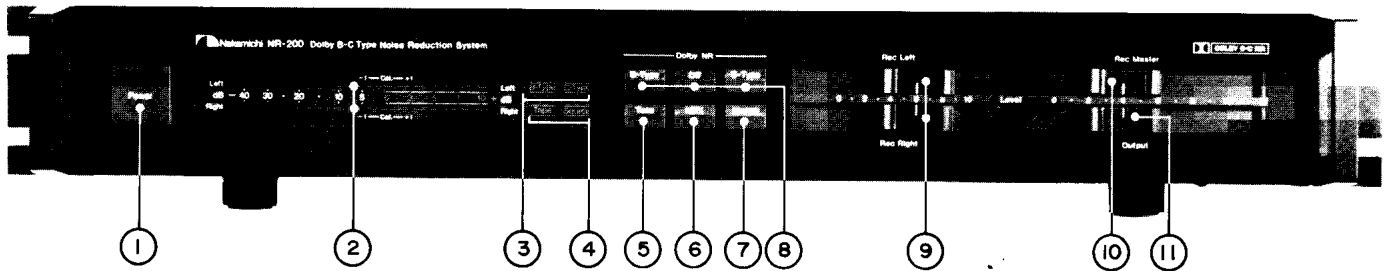

Fig. 1.1 Front View

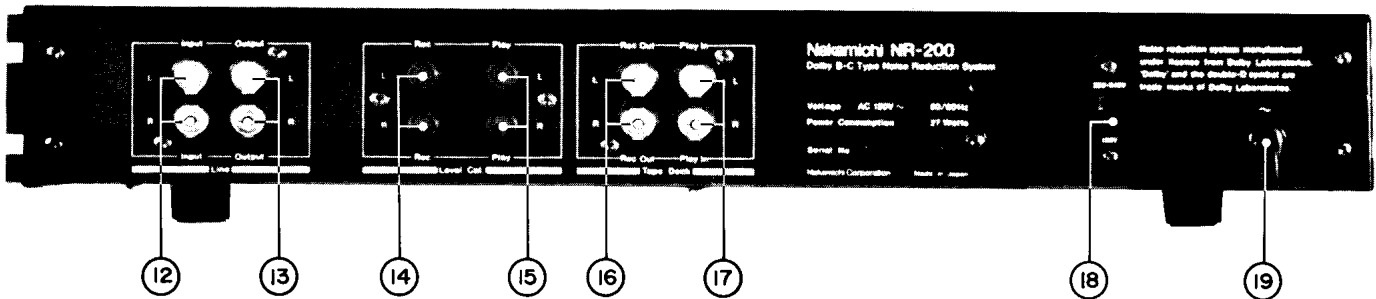

Fig. 1.2 Rear View

- | | |
|------------------------------|-----------------------------------|
| 1. Power Switch | 11. Output Level Control |
| 2. Peak Level Meters | 12. Line Input Jacks |
| 3. Noise Reduction Indicator | 13. Line Output Jacks |
| 4. Monitor Indicator | 14. Calibration Controls (Record) |
| 5. Tone Switch | 15. Calibration Controls (Play) |
| 6. MPX Filter Switch | 16. Record Out Jacks |
| 7. Monitor Switch | 17. Play In Jacks |
| 8. Dolby NR Switches | 18. Voltage Selector Switch |
| 9. Record Level Controls | 19. Power Cord |
| 10. Master Level Control | |

1.2. Voltage Selector

Voltage selector is installed on the rear panel for Other Version of the Nakamichi NR-200. This voltage selector can select either 120 V or 220-240 V at customer's disposal.

1.3. Attention to Servicemen

Before returning the repaired NR-200 to a customer, check to insure that the exposed part is accurately insulated from the AC line by measuring the leakage current or the insulation resistance between them.

2. REMOVAL PROCEDURES

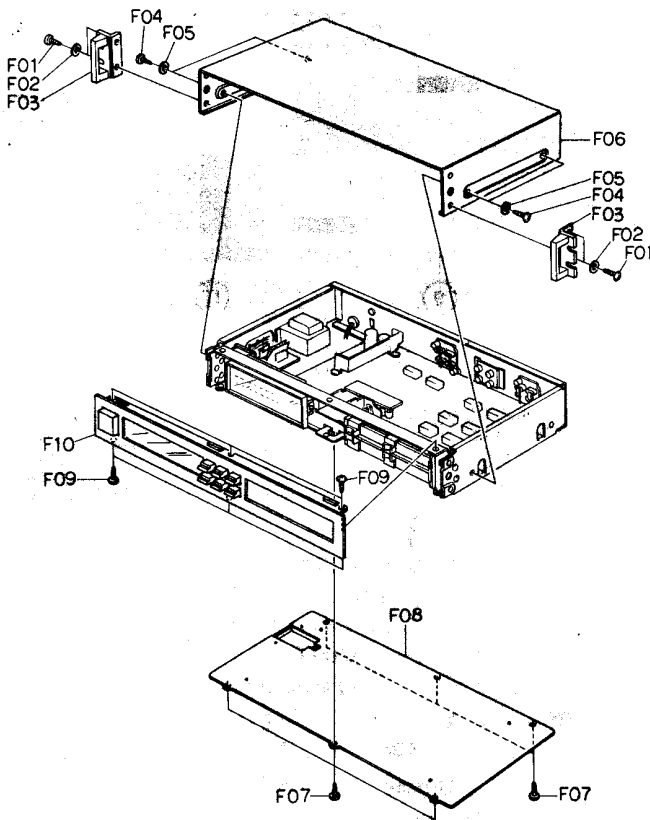

Fig. 2.1

2.1. Side Plates

Refer to Fig. 2.1.

- (1) Remove F01 and F02, then disassemble F03 (Side Plate).

2.2. Top Cover Ass'y

Refer to Fig. 2.1.

- (1) Remove Side Plates referring to item 2.1.
- (2) Remove F04 and F05, then disassemble F06 (Top Cover Ass'y).

2.3. Bottom Cover Ass'y

Refer to Fig. 2.1.

- (1) Remove F07, then disassemble F08 (Bottom Cover Ass'y).

2.4. Front Panel Ass'y

Refer to Fig. 2.1.

- (1) Remove Top Cover Ass'y and Bottom Cover Ass'y referring to items 2.2 and 2.3.
- (2) Remove F09, then disassemble F10 (Front Panel Ass'y).

2.5. Front Chassis Ass'y, Volume P.C.B. Ass'y, Indicator Ass'y and Lamp P.C.B. Ass'y

Refer to Fig. 2.2.

- (1) Refer to Fig. 2.1. Remove Front Panel Ass'y referring to item 2.4.
- (2) Remove F01 and F02, then disassemble F03 (Front Chassis Ass'y).
- (3) Remove F04, then disassemble F05 (Slide Volume Ass'y).
- (4) Remove F06, then disassemble F07 (Volume Knob Ass'y).
- (5) Remove F08, then disassemble F09 (Volume Holder) and F10 (Volume P.C.B. Ass'y).
- (6) Remove F11, then disassemble F12 (Indicator Ass'y).
- (7) Remove F13, then disassemble F14 (Indicator Cover).
- (8) Remove F15, then disassemble F16 (Indicator P.C.B. Ass'y) and F17 (Indicator Holder).
- (9) Remove F18, then disassemble F19 (Lamp P.C.B. Ass'y).

2.6. Main P.C.B. Ass'y and Dolby NR Switch P.C.B. Ass'y

Refer to Fig. 2.3.

- (1) Refer to Fig. 2.1. Remove Front Panel Ass'y referring to item 2.4.
- (2) Pull out F01 (Volume Knob). Remove F02, then disassemble F03 (Calibration Volume Ass'y).
- (3) Remove F04, F05, F07 and F08, then disassemble F06 (Volume) and F09 (Volume).
- (4) Remove F10, F11 and F12, then disassemble F13.
- (5) Remove F14, then disassemble F15 (Dolby NR Switch P.C.B. Ass'y) and F16 (Main P.C.B. Ass'y).

2.7. Power Transformer and Fuse P.C.B. Ass'y

Refer to Fig. 2.3.

- (1) Refer to Fig. 2.1. Remove Top Cover Ass'y referring to item 2.2.
- (2) Remove F17 and F18, then disassemble F19 (Power Transformer).
- (3) Remove F20, then disassemble F21 (Insulator) and F22 (Fuse P.C.B. Ass'y).

2.8. Power Switch

Refer to Fig. 2.3.

- (1) Refer to Fig. 2.1. Remove Front Panel Ass'y referring to item 2.4.
- (2) Remove F23, then disassemble F24 (Power Switch).

2.9. Rear Panel Ass'y

Refer to Fig. 2.3.

- (1) Refer to Fig. 2.1. Remove Top Cover Ass'y and Bottom Cover Ass'y referring to items 2.2 and 2.3.
- (2) Remove F25, then disassemble F26 (Rear Panel Ass'y).

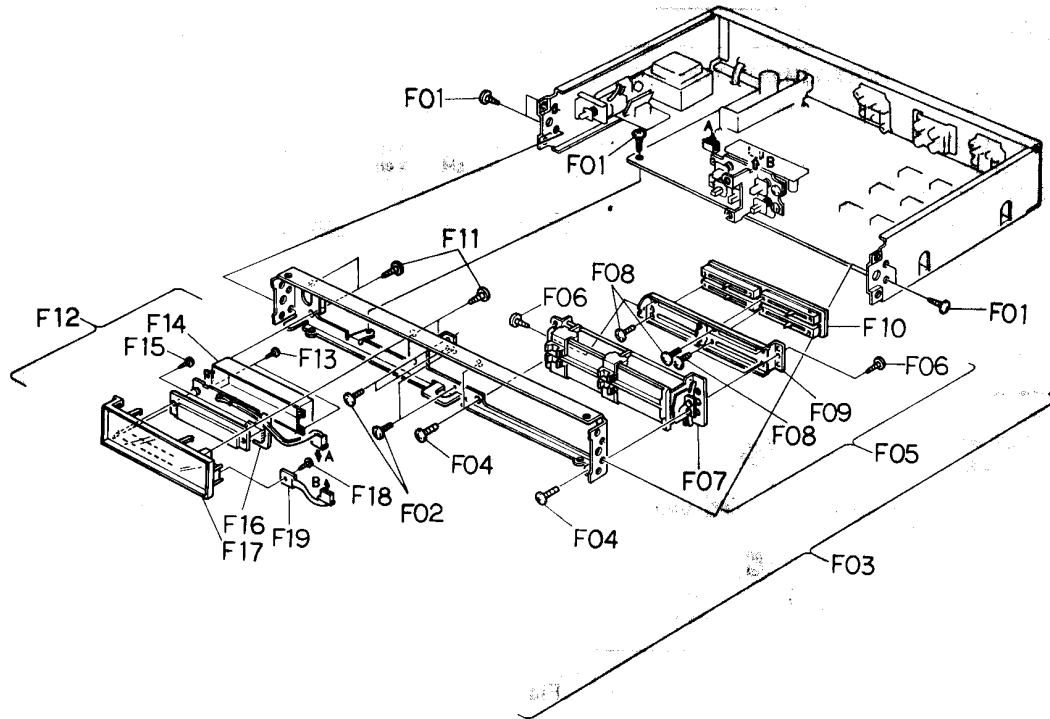

Fig. 2.2

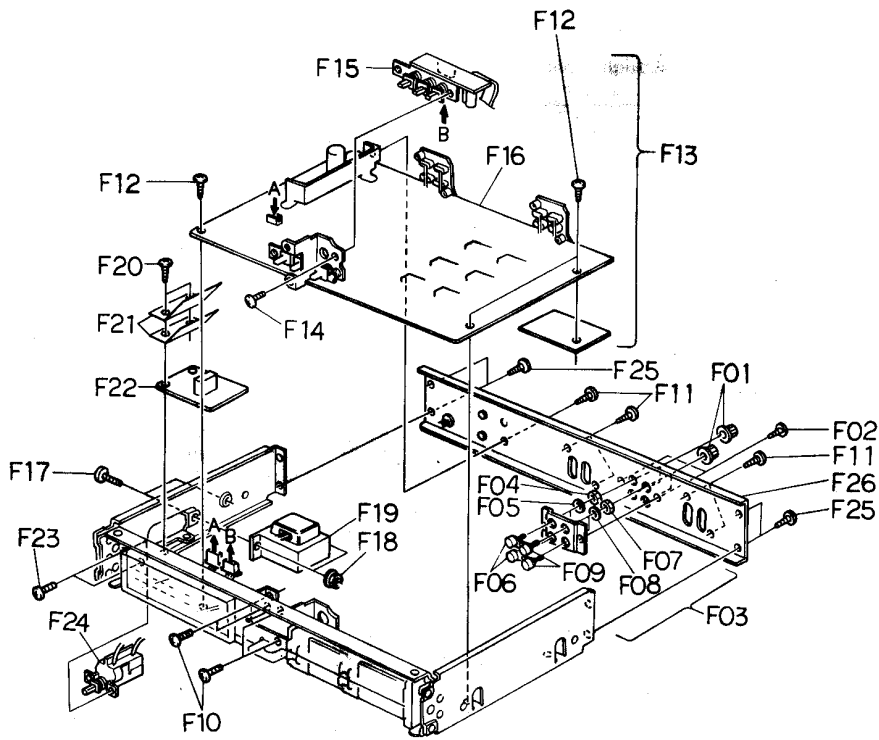

Fig. 2.3

3. PARTS LOCATION FOR ELECTRICAL ADJUSTMENT

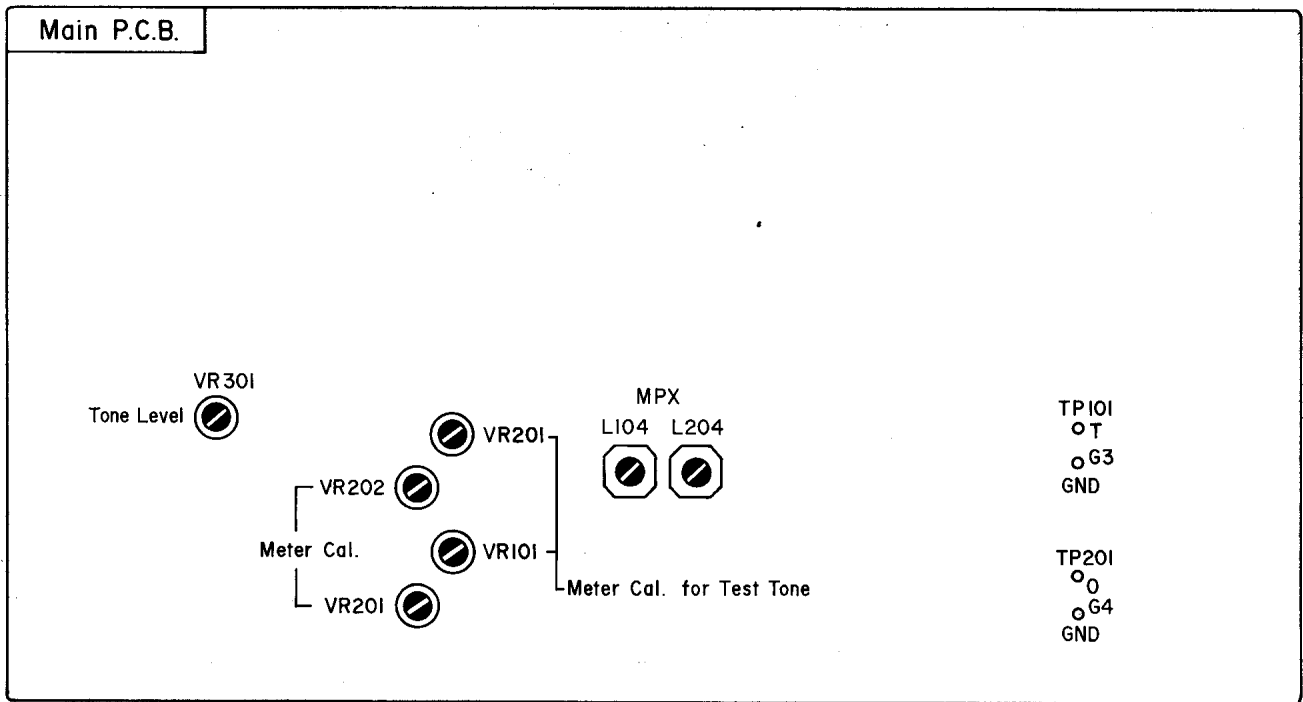

Fig. 3

4. ELECTRICAL ADJUSTMENTS AND MEASUREMENTS

4.1. Adjustment and Measurement Instructions

STEP	ITEM	SIGNAL SOURCE	OUTPUT CONNECTION	MODE	ADJUSTMENT	REMARKS
1	Tone Level Calibration and Meter Calibration for Test Tone	Test Tone 400 Hz	VTVM to TP101, TP201 on Main P.C.B.	Monitor SW – Source Tone SW – ON Dolby NR SW – OFF	in P.C.B. 301 101, VR201	1. Adjust VR301 to obtain 90 mV –0.4 dB on the VTVM. 2. Adjust VR101 (VR201) so that the 0 dB segment of the level meter starts illuminating. 3. Adjust VR301 to obtain 90 mV on the VTVM.
2	Meter Calibration	400 Hz 90 mV –0.4 dB and 400 Hz 90 mV to Line Input Jacks	VTVM to TP101, TP201 on Main P.C.B.	Monitor SW – Source Tone SW – OFF Dolby NR SW – OFF	in P.C.B. 102, VR202	1. Feed in 400 Hz 90 mV –0.4 dB. 2. Adjust VR102 (VR202) so that the 0 dB segment of the level meter starts illuminating. 3. Feed in 400 Hz 90 mV, then decrease the generator output level by 20 dB. 4. Check to insure that the segment located either at 4th or 5th from the left hand of the level meter lights up.
3	MPX Filter Adjustment	19 kHz ± 100 Hz to Line Input Jacks	VTVM to Line Output Jacks	Monitor SW – Source Tone SW – OFF Dolby NR SW – OFF MPX SW – OFF/ON	in P.C.B. D4, L204	1. Set the Output level control to max. 2. Adjust the Record level controls to obtain 600 mV (0 dB) on the VTVM. 3. Set the MPX Filter switch to ON. 4. Adjust L104 (L204) to obtain the minimum reading on the VTVM (the minimum reading will be less than –30 dB).
4	Record Level Calibration	400 Hz (0 dB) to Line Input Jacks	VTVM to Line Output Jacks	Monitor SW – Tape Tone SW – OFF Dolby NR SW – OFF MPX SW – OFF		1. Connect the Record Out jacks and the Play In jacks. 2. Set the Record level controls, Master level control and Output level control to max. 3. Feed in 400 Hz 0 dB. 4. Adjust the Record Level Calibration controls on the rear panel to obtain 600 mV (0 dB) on the VTVM.
5	Overall Frequency Response Measurement	20 Hz – 20 kHz [–20 dB] to Line Input Jacks	VTVM to Line Output Jacks	Monitor SW – Tape Tone SW – OFF Dolby NR SW – B-Type/C-Type MPX SW – OFF		1. Connect the Record Out jacks and the Play In jacks. 2. Conduct step 4 "Record Level Calibration". 3. Set the Dolby NR switch to B-Type/C-Type. 4. Feed in 20 Hz – 20 kHz –20 dB, then check to insure that the readings are within –20 dB ± 1 dB on the VTVM.
6	Total Harmonic Distortion Measurement	400 Hz (0 dB) to Line Input Jacks	Distortion Meter to Line Output Jacks	Monitor SW – Tape Tone SW – OFF Dolby NR SW – B-Type/C-Type MPX SW – OFF		1. Connect the Record Out jacks and the Play In jacks. 2. Conduct step 4 "Record Level Calibration". 3. Set the Dolby NR switch to B-Type/C-Type. 4. Read the distortion meter.
7	Signal to Noise Ratio Measurement	400 Hz (0 dB) to Line Input Jacks	VTVM to Line Output Jacks	Monitor SW – Tape Tone SW – OFF Dolby NR SW – B-Type/C-Type MPX SW – OFF		1. Connect the Record Out jacks and the Play In jacks. 2. Conduct step 4 "Record Level Calibration". 3. Remove the input from the Line Input jacks, then connect the signal side and ground side of the Line Input jacks with shorting plugs. 4. Set the Dolby NR switch to B-Type/C-Type. 5. Read the noise level on the VTVM. Note: The filter of IHF-A curve shall be used in the measurements.

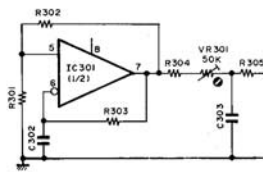

Fig. 4.1
1. Tone Level

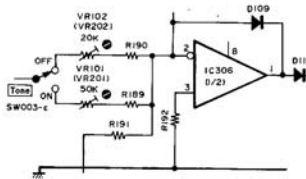

Fig. 4.2
1. Meter Calibration for Test Tone
2. Meter Calibration

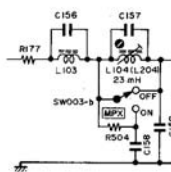

Fig. 4.3
3. MPX Filter

4.2. Dolby NR Circuit Check

Dolby NR circuit incorporates a Dolby NR IC (μ A7300-PC) which has no adjustment point.

Perform the following checks and make sure that the IC operates accurately, i.e., accuracy of frequency response through IC.

4.2.1. Dolby NR B-Type Circuit Check

(1) Decoder

Signal Source: 1.4 kHz to Play In Jacks
 Output Connection: VTVM to IC103-14 and IC-203-14 on the Main P.C.B.
 Mode: Playback Level Calibration Controls (on Rear Panel) – max.
 Dolby NR SW – B-Type/
 OFF

- Connect a VTVM to IC103-14 (IC203-14) on the Main P.C.B.
- Set the Dolby NR switch to B-Type. Feed in 1.4 kHz to the Play In jacks and adjust the generator output control to obtain 9 mV on the VTVM.
- Set the Dolby NR switch to OFF. Check to insure that the reading is $+3.2 \text{ dB} \pm 1.5 \text{ dB}$ on the VTVM.

(2) Encoder

Signal Source: 1.4 kHz to Line Input Jacks
 Output Connection: VTVM to test points TP101 and TP201 on the Main P.C.B. and Record Out Jacks
 Mode: Tone SW – OFF
 MPX SW – OFF
 Record Level Calibration Controls (on Rear Panel) – max.
 Dolby NR SW – B-Type/
 OFF

- Connect a VTVM to TP101 (TP201) on the Main P.C.B.
- Feed in 1.4 kHz and adjust the Record level controls to obtain 9 mV/2.85 mV on the VTVM.
- Remove the VTVM from TP101 (TP201) and re-connect it to the Record Out jacks.
- Check to insure that the readings at the Record Out jacks correspond to the following with Dolby NR switch OFF and B-Type.

Input Level at TP101 (TP201)	Level at Record Out Jacks	
	Dolby NR OFF	Dolby NR B-Type
9 mV	0 dB	$+3.2 \text{ dB} \pm 1.5 \text{ dB}$

4.2.2. Dolby NR C-Type Circuit Check

(1) Decoder

Signal Source: 1.4 kHz to Play In Jacks
 Output Connection: VTVM to IC103-14 and IC-203-14 on the Main P.C.B.
 Mode: Playback Level Calibration Controls (on Rear Panel) – max.
 Dolby NR SW – C-Type/
 OFF

- Connect a VTVM to IC103-14 (IC203-14) on the Main P.C.B.
- Set the Dolby NR switch to C-Type. Feed in 1.4 kHz to the Play In jacks and adjust the generator output control to obtain 9 mV on the VTVM.
- Set the Dolby NR switch to OFF. Check to insure that the reading is $+6.5 \text{ dB} \pm 1.5 \text{ dB}$ on the VTVM.

(2) Encoder

Signal Source: 1.4 kHz to Line Input Jacks
 Output Connection: VTVM to test points TP101 and TP201 on the Main P.C.B. and Record Out Jacks
 Mode: Tone SW – OFF
 MPX SW – OFF
 Record Level Calibration Controls (on Rear Panel) – max.
 Dolby NR SW – C-Type/
 OFF

- Connect a VTVM to TP101 (TP201) on the Main P.C.B.
- Feed in 1.4 kHz and adjust the Record level controls to obtain 9 mV/2.85 mV on the VTVM.
- Remove the VTVM from TP101 (TP201) and re-connect it to the Record Out jacks.
- Check to insure that the readings at the Record Out jacks correspond to the following with Dolby NR switch OFF and C-Type.

Input Level at TP101 (TP201)	Level at Record Out Jacks	
	Dolby NR OFF	Dolby NR C-Type
9 mV	0 dB	$+6.5 \text{ dB} \pm 1.5 \text{ dB}$
2.85 mV	0 dB	$+11.4 \text{ dB} \pm 1.5 \text{ dB}$

5. MOUNTING DIAGRAMS AND PARTS LIST

Note: Mounting diagram shows a dip side view of the printed circuit board.

5.1. Indicator P.C.B. Ass'y

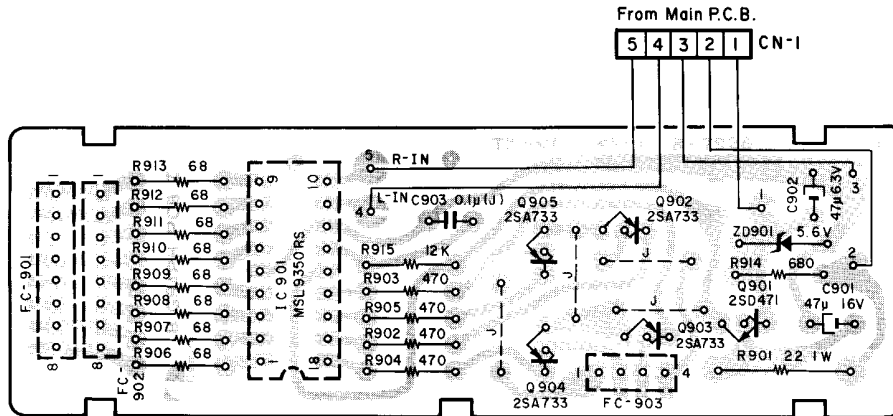

Fig. 5.1

5.2. Dolby NR Switch P.C.B. Ass'y

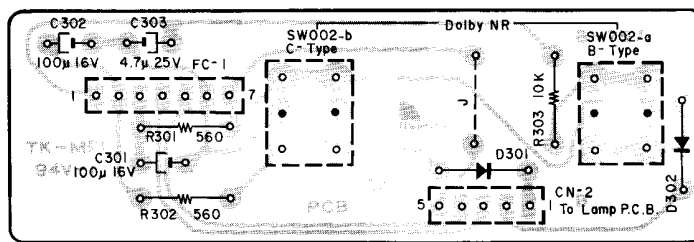

Fig. 5.2

Note: Diode is 1SS53 unless otherwise specified.

Schematic Ref. No.	Part No.	Description	Schematic Ref. No.	Part No.	Description
	BA04452A	Indicator P.C.B. Ass'y		BA04439A	Dolby NR Switch P.C.B. Ass'y
IC901	0B07928A	Indicator P.C.B.	D301,302	0B07971B	Dolby NR Switch P.C.B.
Q901	0B06284A	IC MSL9350RS	R301,302	0B06181A	Silicon Diode 1SS53
Q902,903 904,905	0B06066A	Transistor 2SD471	R303	0B05575A	Carbon Resistor 560 ERD-25T J
ZD901	0B06013A	Transistor 2SA733	C301,302	0B01888A	Carbon Resistor 10K ERD-25T J
R901	0B06268A	Zener Diode 5.6V RD5.6EB3	C303	0B01400A	Electrolytic Capacitor 100μ 16V
R902,903 904,905	0B09378A	Fail Safe Type Resistor 22 RSF-1B J	CN2	0B01402A	Electrolytic Capacitor 4.7μ 25V
R906,907 908,909 910,911 912,913	0B05576A	Carbon Resistor 470 ERD-25T J	SW002	0B08724A	5P-T Post
R914	0B01704A	Carbon Resistor 68 ERD-25T J		0B07373A	Push Switch 2-0-2
R915		Carbon Resistor 12K ERD-25T J		0B05235A	Flat Cable 7P (1 pce.)
C901	0B05794A	Carbon Resistor 680 ERD-25T J			
C902	0B09263A	Carbon Resistor 12K ERD-25T J			
C903	0B01403A	Electrolytic Capacitor 47μ 16V			
FC901	0B01404A	Electrolytic Capacitor 47μ 6.3V			
FC902	0B01780A	Mylar Capacitor 0.1μ 50V J			
FC903	0B05236A	Flat Cable 8P			
CN1	0B05251A	Flat Cable 8P 80mm			
	0B05252A	Flat Cable 4P 35mm			
	0B05258A	5P-H Connector (1 pce.)			
	0B06291A	Indicator (1 pce.)			

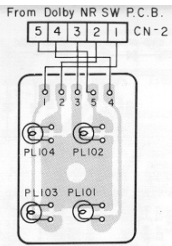

Fig. 5.3

5.4. Volume P.C.B. Ass'y

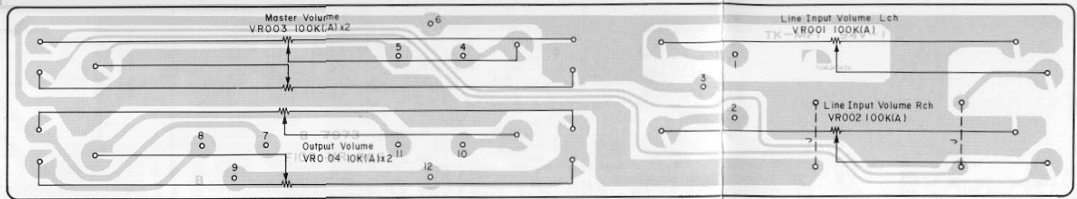

Fig. 5.4

5.5. Fuse P.C.B. Ass'y

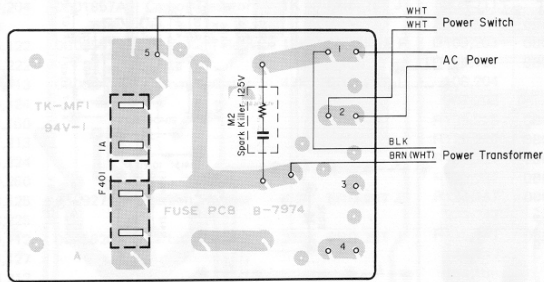

Fig. 5.5.1 U.S.A., Canada & Japan

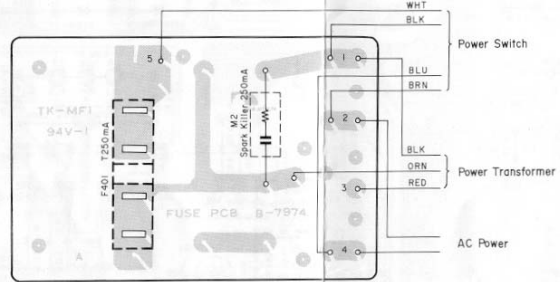

Fig. 5.5.3 UK & Australia

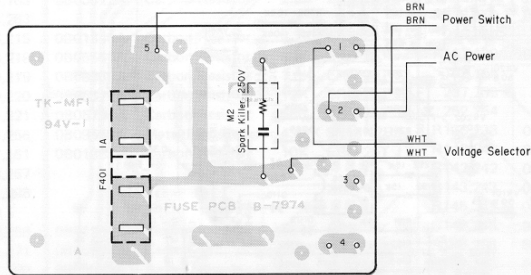

Fig. 5.5.2 Others

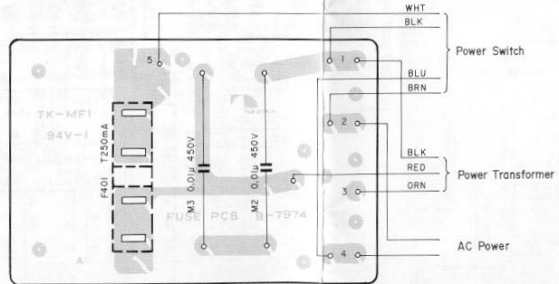

Fig. 5.5.4 220 V Class 2

Main P.C.B. Ass'y

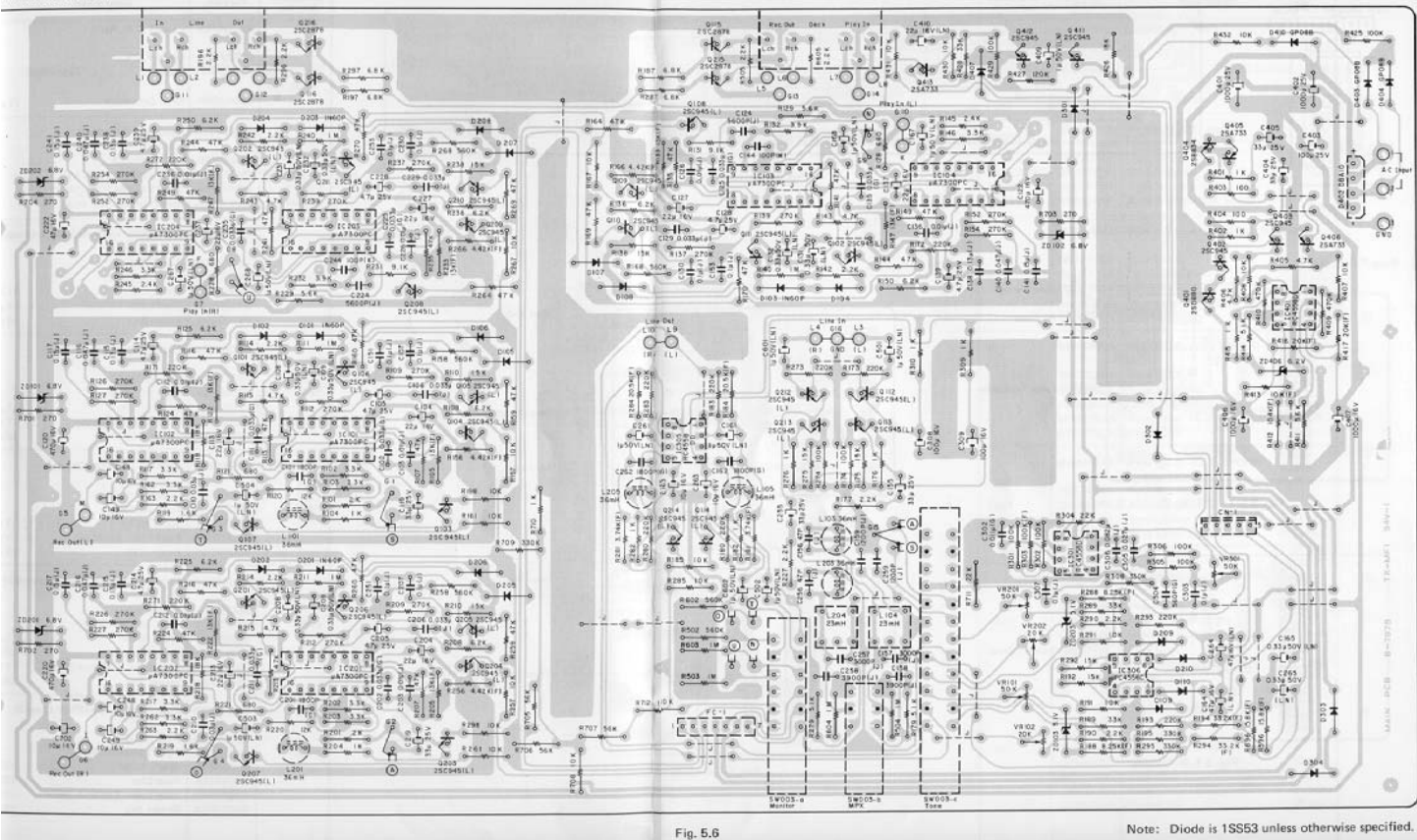

Fig. 5.6

Note: Diode is 1SS53 unless otherwise specified.

Schematic Ref. No.	Part No.	Description	Schematic Ref. No.	Part No.	Description	Schematic Ref. No.	Part No.	Description	Schematic Ref. No.	Part No.	Description
	BA0442A	Main P.C.B. Assy									
	- Encoder										
IC101,102	0B06200A	IC μ A7300PC	C108,109	0B09567A	Electrolytic Capacitor 0.33 μ 50V (LN)	C130,153	0B01780A	Mylar Capacitor 0.1 μ 50V J	D109,110	0B06181A	Silicon Diode 1S553 (7 pcs.)
201,202			208,209			230,253			209,210		
103-107	0B01872A	Transistor 2SC945 (L)	C110,210	0B09594A	Mylar Capacitor 0.03 μ 50V J	C131,132	0B09567A	Electrolytic Capacitor 0.33 μ 50V (LN)	302-304	0B03919A	Inductor 36mH
201			C115,215	0B09596A	Mylar Capacitor 0.1 μ 50V J	231,232			L103,105		
203-207			C116,216	0B05796A	Mylar Capacitor 0.047 μ 50V J	C132,236			203,205	0B03563A	19 kHz Coil 23mH
ZD101,201	0B06167A	Zener Diode 6.8V RD6.8E83	C117,217	0B05914A	Mylar Capacitor 0.15 μ 50V J	C140,240	0B09566A	Mylar Capacitor 0.1 μ 50V J	L104,204	0B02788A	Semi-fixed Volume 50K
D101,201	0B00030A	Germanium Diode 1N60P	C119,219	0B09576A	Electrolytic Capacitor 33 μ 10V	C141,241	0B09591A	Mylar Capacitor 0.047 μ 50V J	VR101,201		
D102,106	0B06181A	Silicon Diode 1S553	C120,220	0B01392A	Electrolytic Capacitor 470 μ 16V	C144,244	0B09282A	Ceramic Capacitor 100P 50V K	301	0B02720A	Semi-fixed Volume 20K
106,202			C148,149	0B01412A	Electrolytic Capacitor 10 μ 16V	C167,168	0B09223A	Electrolytic Capacitor 1 μ 50V (LN)	VR102,202	0B05625A	Carbon Resistor 220K ERD-25T J
205,206			248,249			267,268			183,193		
L101,201	0B03918A	Inductor 36mH	702	0B09223A	Electrolytic Capacitor 1 μ 50V (LN)				273,280		
R101,201	0B09301A	Carbon Resistor 2K ERD-25T J		0B08714A	IC Socket 16P (4 pcs.)				283,293		
R102,103	0B01681A	Carbon Resistor 3.3K ERD-25T J		- Decoder					R174,274	0B01899A	Carbon Resistor 100K ERD-25T J
117,162									301,302		
202,203			IC103,104	0B06200A	IC μ A7300PC	IC401	0B06124B	IC RC4558D	305,306		
217,262			203,204			O407	0B06256A	Transistor 2SD880	R175,192	0B01683A	Carbon Resistor 15K ERD-25T J
R104,204	0B01957A	Carbon Resistor 1K ERD-25T J	O102	0B01872A	Transistor 2SC945 (L)	O402,403	0B06100A	Transistor 2SC945 (A)	R176,182	0B01897A	Carbon Resistor 1K ERD-25T J
704			108-111			411,412			276,282		
R105,122	0B09557A	Metal Film Resistor 13K SN14K2E F	208-211			O404	0B06256A	Transistor 2SB834	309,310		
205,222			ZD102,202	0B06167A	Zener Diode 6.8V RD6.8E83	O405,406	0B06013A	Transistor 2SA733	R177,190	0B05622A	Carbon Resistor 2.2K ERD-25T J
R107,113	0B05641A	Carbon Resistor 47K ERD-25T J	D103,203	0B00030A	Germanium Diode 1N60P	413			196,277		
116,124			D104,107	0B06181A	Silicon Diode 1S553	ZD496	0B06167A	Zener Diode 5.2V RD6.2E83	290,296		
159,160			108,204			D301,401	0B01811A	Silicon Diode 1S553	505,606		
207,213			207,208			D402	0B06282A	Diode Bridge DBA10	R179,279	0B0388A	Carbon Resistor 5.1K ERD-25T J
216,224			R128,228	0B05794A	Carbon Resistor 680 ERD-25T J	D403,404	0B06109A	Silicon Diode GP08B	R181,281	0B09573A	Metal Film Resistor 3.74K SN14K2E F
259,260			R129,229	0B01897A	Carbon Resistor 5.6K ERD-25T J	R400,404	0B01679A	Carbon Resistor 100 ERD-25T J	R184,284	0B09574A	Metal Film Resistor 20.5K SN14K2E F
R108,125	0B09271A	Carbon Resistor 6.2K ERD-25T J	R131,231	0B09226A	Carbon Resistor 9.1K ERD-25T J	R405,406	0B01946A	Carbon Resistor 4.7K ERD-25T J	R185,191	0B01888A	Carbon Resistor 10K ERD-25T J
208,225			R132,232	0B05675A	Carbon Resistor 3.9K ERD-25T J	R407,408	0B01898A	Carbon Resistor 10K ERD-25T J	712		
R109,112	0B05620A	Carbon Resistor 270K ERD-25T J	R133,147	0B09557A	Metal Film Resistor 13K SN14K2E F	430,431			R187,197	0B01682A	Carbon Resistor 6.8K ERD-25T J
128,127			R135,141			432			287,297		
209,212			144,149			R409,410	0B01684A	Carbon Resistor 470K ERD-25T J	R188,288	0B09432A	Metal Film Resistor 6.25K SN14K2E F
226,227			164,169			R411	0B01827A	Carbon Resistor 5.6K ERD-25T J	R189,289	0B05899A	Carbon Resistor 33K ERD-25T J
R110,210	0B01683A	Carbon Resistor 15K ERD-25T J	170,205			R412	0B09433A	Metal Film Resistor 10.4K SN14K2E F	R194,294	0B09446A	Metal Film Resistor 33.2K SN14K2E F
R111,211	0B05776A	Carbon Resistor 1M ERD-25T J	241,244			R413	0B09203A	Metal Film Resistor 10K SN14K2E F	R195,295	0B06627A	Carbon Resistor 330K ERD-25T J
R114,163	0B05622A	Carbon Resistor 2.2K ERD-25T J	249,264			R414	0B0388A	Carbon Resistor 5.1K ERD-25T J	308		
214,263			269,270			R416,417	0B09439A	Metal Film Resistor 20K SN14K2E F	R303	0B05305A	Metal Film Resistor 100K SN14K2E F
R115,215	0B01846A	Carbon Resistor 4.7K ERD-25T J	R136,150	0B09271A	Carbon Resistor 6.2K ERD-25T J	R425,429	0B01899A	Carbon Resistor 100K ERD-25T J	R304,711	0B05615A	Carbon Resistor 22K ERD-25T J
R118,218	0B05660A	Carbon Resistor 18K ERD-25T J	235,250	0B05620A	Carbon Resistor 270K ERD-25T J	R426	0B05650A	Carbon Resistor 18K ERD-25T J	R502,602	0B05794A	Carbon Resistor 560K ERD-25T J
R119,219	0B09565A	Carbon Resistor 1.6K ERD-25T J	R137,139			R427	0B06621A	Carbon Resistor 120K ERD-25T J	R503,504	0B05776A	Carbon Resistor 1 M ERD-25T J
R120,220	0B05671A	Carbon Resistor 12K ERD-25T J	152,154			R428	0B06509A	Carbon Resistor 33K ERD-25T J	603,604		
R121,221	0B05794A	Carbon Resistor 680 ERD-25T J	237,239			C401,402	0B01870A	Electrolytic Capacitor 1000 μ 25V	R596,696	0B09437A	Metal Film Resistor 15.8K SN14K2E F
R156,256	0B09558A	Metal Film Resistor 4.42K SN14K2E F	R138,238	0B01683A	Carbon Resistor 15K ERD-25T J	C403	0B01272A	Electrolytic Capacitor 100 μ 25V	C156,256	0B09251A	Electrolytic Capacitor 33 μ 25V
R157,161	0B01888A	Carbon Resistor 10K ERD-25T J	R140,240	0B05776A	Carbon Resistor 1M ERD-25T J	C404,405	0B09251A	Electrolytic Capacitor 33 μ 25V	C156,256	0B09242A	Mica Capacitor 47P 50V J
198,267			R142,242	0B05622A	Carbon Resistor 2.2K ERD-25T J	C406,407	0B01397A	Electrolytic Capacitor 1000 μ 16V	C157,257	0B09262A	PP Capacitor 3000P 100V J
261,269			R143,243	0B01846A	Carbon Resistor 4.7K ERD-25T J	C409	0B09223A	Electrolytic Capacitor 1 μ 50V (LN)	C158,258	0B01894A	Mylar Capacitor 3900P 50V J
708			R146,246	0B09558A	Carbon Resistor 2.4K ERD-25T J	C410	0B09137A	Electrolytic Capacitor 22 μ 16V (LN)	C159,259	0B06627A	Mylar Capacitor 1200P 50V J
R158,258	0B05784A	Carbon Resistor 560K ERD-25T J	R166,266	0B09558A	Metal Film Resistor 4.42K SN14K2E F	OE00607A		Nut Hex. M3 (2 pcs.)	C181,261	0B09223A	Electrolytic Capacitor 1 μ 50V (LN)
R171,271	0B05625A	Carbon Resistor 220K ERD-25T J	0B01898A	Carbon Resistor 10K ERD-25T J		OE00607A		Screw M3x8 Philips Pan Head (3A) (2 pcs.)	501,602		
R701,702	0B05645A	Carbon Resistor 270 ERD-25T J	R167,267	0B05794A	Carbon Resistor 560K ERD-25T J	OE00682A		BT Screw M3x6 Philips Pan Head (2 pcs.)	C162,262	0B09409A	PP Capacitor 1800P 100V G
R705,706	0B05508A	Carbon Resistor 56K ERD-25T J	R168,268	0B05622A	Carbon Resistor 4.7K ERD-25T J	0B01897A		Heat Sink F103 (1 pc.)	C163,263	0B01412A	Electrolytic Capacitor 10 μ 16V (LN)
707			R172,272	0B0565A	Carbon Resistor 270 ERD-25T J	0B0801A		Transistor Micra TO-220 (2 pcs.)	C164,264	0B09218A	Electrolytic Capacitor 47 μ 16V (LN)
R709	0B05627A	Carbon Resistor 330K ERD-25T J	R703,704	0B01392A	Electrolytic Capacitor 470 μ 16V	0B0801A			C166,266	0B06327A	Electrolytic Capacitor 0.01 μ 50V (LN)
C101,201	0B09409A	PP Capacitor 1800P 100V G	C122,222	0B05659A	Mylar Capacitor 5600P 50V J	IC301	0B06124B	IC RC4558D	C302	0B09412A	PP Capacitor 0.1 μ 50V J
C102,111	0B09240A	PP Capacitor 0.033 μ 100V G	C124,224	0B0659A	PP Capacitor 5600P 50V J	IC305	0B06146A	IC μ PC4558D	C303,307	0B01780A	PP Capacitor 560P 100V G
202,211			C125,136	0B06240A	PP Capacitor 0.033 μ 100V G	IC306	0B06216A	IC RC4558D	C304	0B09414A	Mylar Capacitor 560P 100V G
C103,112	0B05681A	Mylar Capacitor 0.01 μ 50V J	225,235			IC103	0B06182A	IC μ PC4558D	C305	0B09045A	Mylar Capacitor 0.027 μ 50V J
203,212			226,236			IC106	0B06182A	IC μ PC4558D	C306	0B05685A	Mylar Capacitor 0.082 μ 50V J
C104,113	0B01892A	Electrolytic Capacitor 22 μ 16V	C127,137	0B01892A	Electrolytic Capacitor 22 μ 16V	Q112,113	0B06182A	Transistor 2SC945 (L)	C308,309	0B01400A	Electrolytic Capacitor 100 μ 16V
204,213			227,237			114,212			C309	0B07372A	Push Switch 8-2-4
C106,114	0B01402A	Electrolytic Capacitor 4.7 μ 25V	C128,139	0B01402A	Electrolytic Capacitor 4.7 μ 25V	213,214			CN1	0B08724A	SP-T Post
205,214			229,239			Q115,116	0B06299A	Transistor 2SC2878		0B08989A	4P Pin Jack (2 pcs.)
C108,206	0B05683A	Mylar Capacitor 0.033 μ 50V J	C129,229	0B05583A	Mylar Capacitor 0.033 μ 50V J	ZD103,203	0B06058A	Zener Diode 5.1V YZ051		- Miscellaneous -	
C107,161	0B01780A	Mylar Capacitor 0.1 μ 50V J								0B07975B	Main P.C.B.

NR-200

6. MECHANISM ASS'Y AND PARTS LIST

6.1. Synthesis Mechanism Ass'y

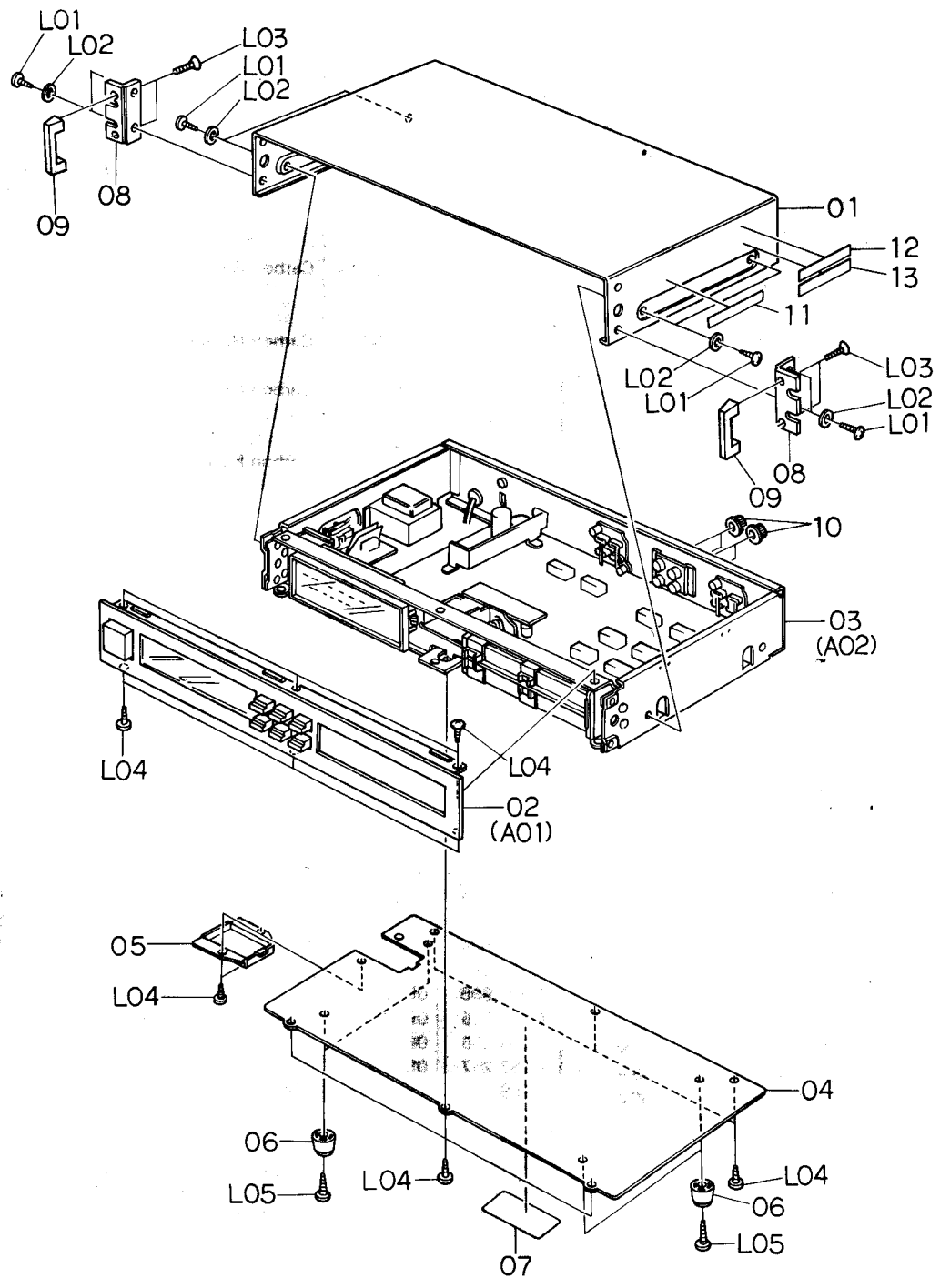

Fig. 6.1

6.2. Front Panel Ass'y (A01)

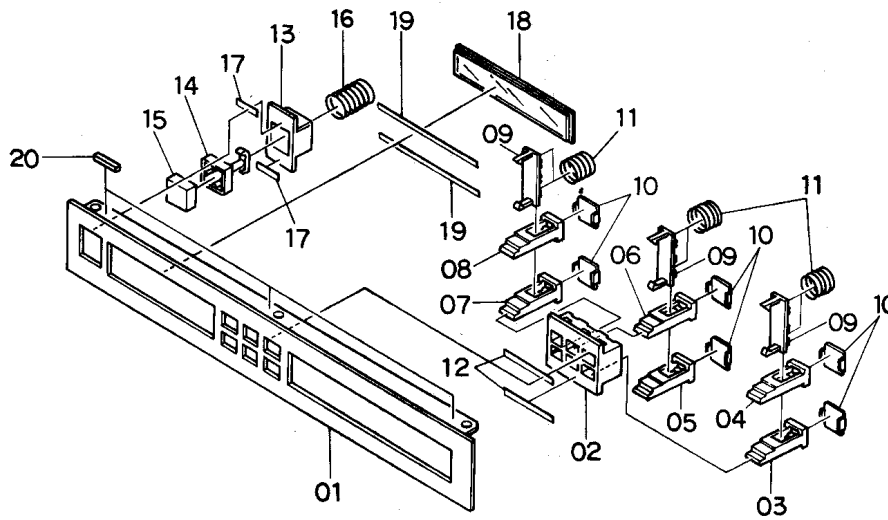

Fig. 6.2

Schematic Ref. No.	Part No.	Description	Q'ty	Schematic Ref. No.	Part No.	Description	Q'ty
	HA04159A	Synthesis Mechanism Ass'y (U.S.A. & Canada)	1	A01	HA04163A	Front Panel Ass'y Serial No.: F10301001 -	1
	HA04158A	Synthesis Mechanism Ass'y (Japan)	1				
	HA04162A	Synthesis Mechanism Ass'y (Others)	1	01	0H03965B	Front Panel	1
	HA04160A	Synthesis Mechanism Ass'y (220V Class 2)	1	02	0H03972A	Switch Flange	1
	HA04161A	Synthesis Mechanism Ass'y (UK)	1	03	0H03971B	Monitor Switch Knob	1
	HA04169A	Synthesis Mechanism Ass'y (Australia) Serial No.: F10301001 -	1	04	0H03968B	C-Type Switch Knob	1
				05	0H03970B	MPX Switch Knob	1
				06	0H03967B	OFF Switch Knob	1
				07	0H03969B	Tone Switch Knob	1
				08	0H03966B	B-Type Switch Knob	1
				09	0J04423B	Switch Flange Holder	3
				10	0J04424A	Switch Knob Cover	6
				11	0J04383B	Push Switch Knob Spring	6
				12	0H03973A	Double-faced Tape for Switch Flange	2
01	0H03962A	Top Cover	1	13	0H03956A	Power Switch Flange	1
02	HA04163A	Front Panel Ass'y	1	14	0H03955A	Power Switch Knob	1
03	JA03876A	Chassis Ass'y (U.S.A. & Canada)	1	15	0H03954A	Power Switch Cover	1
	JA03877A	Chassis Ass'y (Japan)	1	16	0J04384A	Power Switch Spring	1
	JA03873A	Chassis Ass'y (Others)	1	17	0H03957A	Double-faced Tape for Power Switch	2
	JA03874A	Chassis Ass'y (UK)	1	18	0H03974A	Acrylic Scale	1
	JA03875A	Chassis Ass'y (220V Class 2)	1	19	0H03953A	Double-faced Tape for Acrylic Scale	2
	JA03879A	Chassis Ass'y (Australia)	1	20	0H03960A	Cushion	3
04	0J04377A	Bottom Cover	1				
05	0J04378A	Transformer Cover	1				
06	0J03564A	Leg	4				
07	0M04101A	Caution Label	1				
08	0H03963A	Side Plate	2				
09	0H03964A	Handle	2				
10	0H03296B	Volume Knob	4				
11	0M03800A	Caution Label H	1				
12	0M03799A	Caution Label G	1				
13	0M03883B	Lamp Caution Label	1				
L01	0E00953A	BT Screw M4x8 Philips Binding Head (Chromate)	8				
L02	0E00736A	Washer 4mm (Black Chromate)	8				
L03	0E00908A	Screw M4x6 Philips Countersunk (Black Chromate)	4				
L04	0E00857A	BT Screw M3x6 Philips Binding Head	12				
L05	0E00865A	BT Screw M3x8 Philips Binding Head (Chromate)	4				

6.3. Chassis Ass'y (A02)

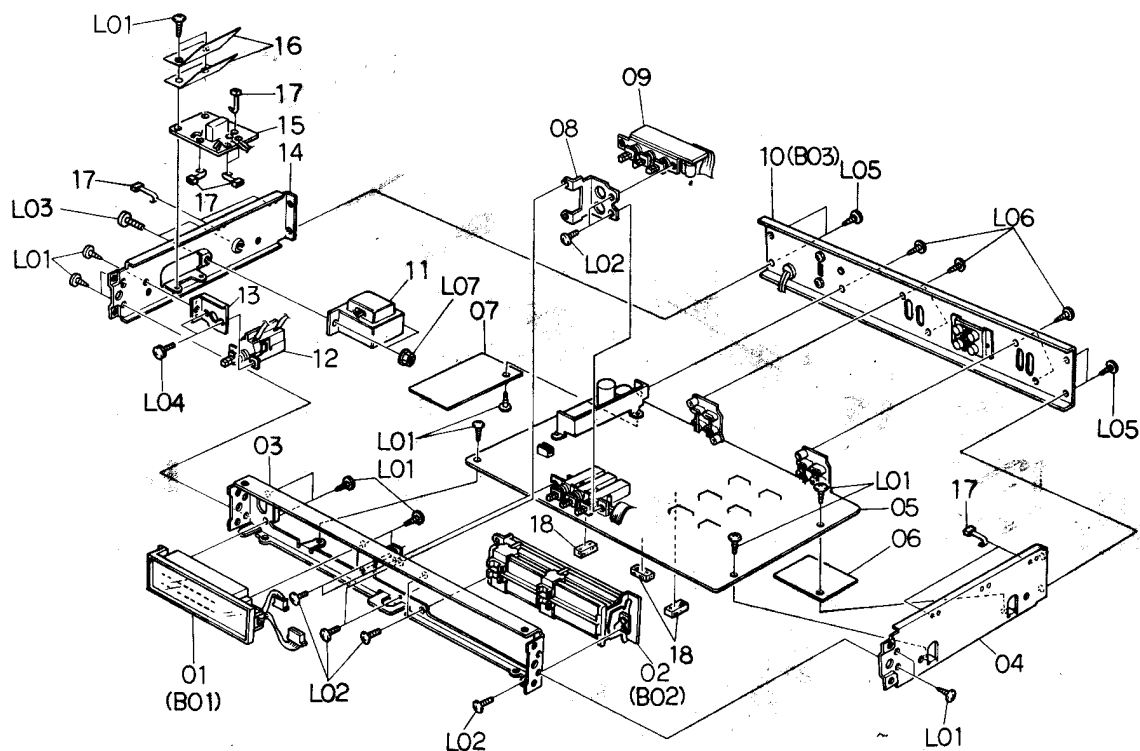

Fig. 6.3

Schematic Ref. No.	Part No.	Description	Q'ty	Schematic Ref. No.	Part No.	Description	Q'ty	
A02	JA03876A	Chassis Ass'y (U.S.A. & Canada)	1	12	0B07299A	Power Switch (U.S.A. & Canada)	1	
	JA03877A	Chassis Ass'y (Japan)	1		0B07301A	Power Switch (Japan)	1	
	JA03873A	Chassis Ass'y (Others)	1		0B07252A	Power Switch (Others, UK, Australia & 220V Class 2)	1	
	JA03874A	Chassis Ass'y (UK)	1		13	0J04419A	Power Switch Holder	1
	JA03875A	Chassis Ass'y (220V Class 2)	1			14	0J04386B	Side Chassis L
	JA03879A	Chassis Ass'y (Australia)	1		15	BA04448A	Fuse P.C.B. Ass'y (U.S.A. & Canada)	1
	Serial No.: F10301001 -			BA04443A	Fuse P.C.B. Ass'y (Japan)	1		
01	JA03855A	Indicator Ass'y	1	BA04451A	Fuse P.C.B. Ass'y (Others)	1		
02	JA03852A	Slide Volume Ass'y	1	BA04450A	Fuse P.C.B. Ass'y (UK & Australia)	1		
03	0J04385B	Front Chassis	1	BA04449A	Fuse P.C.B. Ass'y (220V Class 2)	1		
04	0J04387B	Side Chassis R	1	16	0J04434A	Insulator	2	
05	BA04442A	Main P.C.B. Ass'y	1		17	0B08515A	Insu-Lock	22
06	0J04437A	Fiber A	1	18	0J04342A	Cushion	3	
07	0J04438A	Fiber B	1	L01	0E00857A	BT Screw M3x6 Philips Binding Head	15	
08	0J04382A	Switch Holder	1	L02	0E00896A	Screw M3x6 Philips Binding Head	9	
09	BA04439A	Dolby NR Switch P.C.B. Ass'y	1	L03	0E00953A	Screw M4x10 Philips Binding Head (Black Chromate)	2	
10	HA04165A	Rear Panel Ass'y (U.S.A. & Canada)	1	L04	0E00612A	Screw M3x6 Philips Pan Head (2A)	2	
	HA04164A	Rear Panel Ass'y (Japan)	1	L05	0E00921A	BT Screw M3x8 Philips Binding Head (Black Chromate)	4	
	HA04168A	Rear Panel Ass'y (Others)	1		L06	0E00860A	BT Screw M3x6 Philips Binding Head (Bronze)	5
	HA04167A	Rear Panel Ass'y (UK)	1	L07	0E00928A	Nut Hex. M4	2	
	HA04166A	Rear Panel Ass'y (220V Class 2)	1					
	HA04170A	Rear Panel Ass'y (Australia)	1					
11	0B06658A	Power Transformer (U.S.A. & Canada)	1					
	0B06657A	Power Transformer (Japan)	1					
	0B06660A	Power Transformer (Others)	1					
	0B06659A	Power Transformer (UK, 220V Class 2 & Australia)	1					

6.4. Indicator Ass'y (B01)

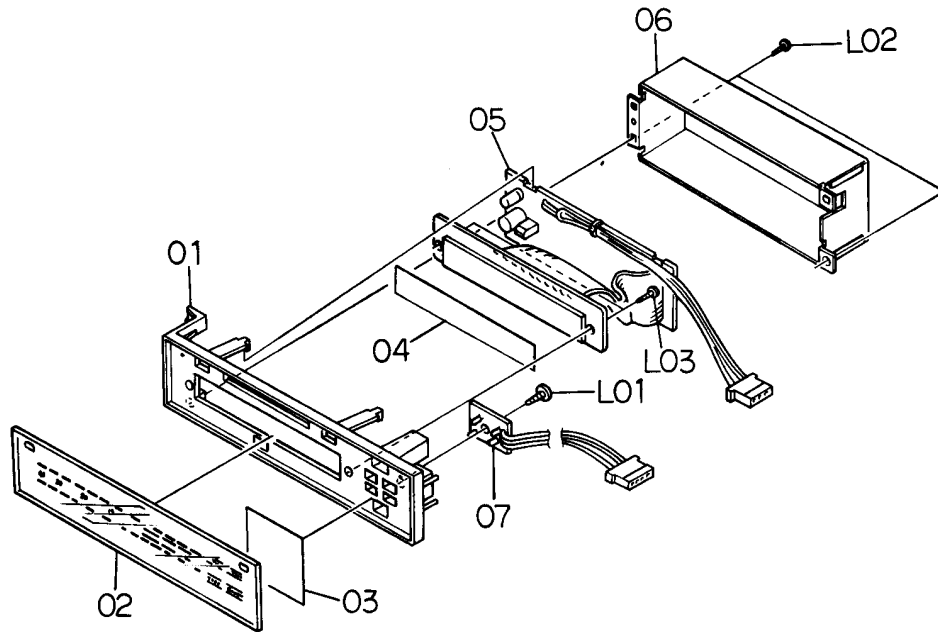

Fig. 6.4

Schematic Ref. No.	Part No.	Description	Q'ty
B01	JA03855A	Indicator Ass'y Serial No.: F10301001 —	1
01	0J04381A	Indicator Holder	1
02	0J04380A	Indicator Scale	1
03	0H03990A	Deflecting Sheet	1
04	0H03988A	Indicator Filter	1
05	BA04452A	Indicator P.C.B. Ass'y	1
06	0J04379A	Indicator Cover	1
07	BA04440A	Lamp P.C.B. Ass'y	1
L01	0E00857A	BT Screw M3x6 Philips Binding Head	1
L02	0E00853A	BT Screw M2x3 Philips Pan Head	2
L03	0E00841A	BT Screw M2x4 Philips Pan Head	2

6.5. Slide Volume Ass'y (B02)

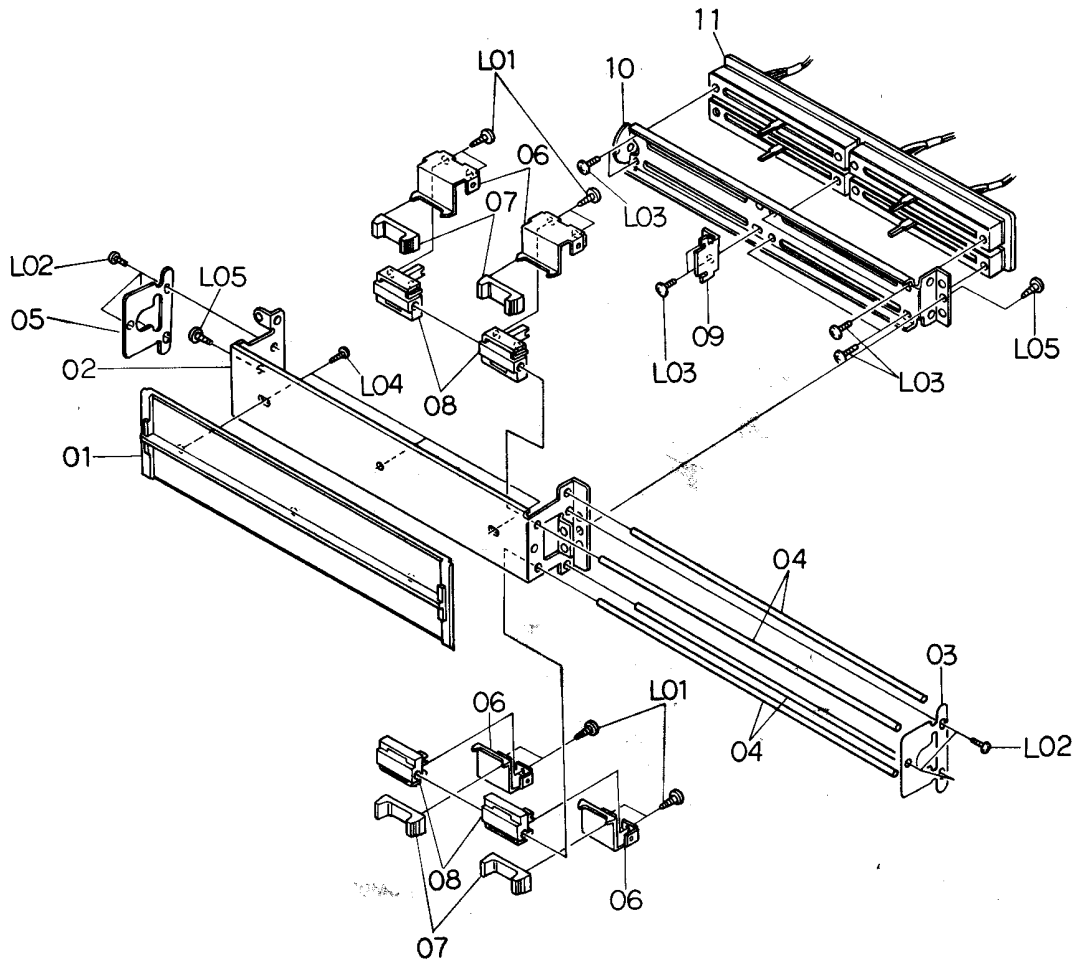

Fig. 6.5

Schematic Ref. No.	Part No.	Description	Q'ty
B02	JA03852A	Slide Volume Ass'y Serial No.: F10301001 -	1
01	0J04376B	Volume Mounting Cover	1
02	0J04371C	Bar Holder	1
03	0T04430A	Slide Shaft Holder B	1
04	0T04373A	Slide Shaft	4
05	0T04375B	Slide Shaft Holder	1
06	0T04393A	Slide Volume Holder	4
07	0H03959B	Slide Volume Knob	4
08	0J04372A	Slide Holder	4
09	0T04429A	Shaft Protector	1
10	0J04374B	Volume Holder	1
11	BA04441A	Volume P.C.B. Ass'y	1
L01	0E00828A	BT Screw M2.6x8 Philips Binding Head (Chromate)	8
L02	0E00790A	ST Screw M2x3 Philips Pan Head (Black Chromate)	6
L03	0E00502A	Screw M3x5 Philips Pan Head	8
L04	0E00841A	BT Screw M2x4 Philips Pan Head	3
L05	0E00857A	BT Screw M3x6 Philips Binding Head	2

6.6. Rear Panel Ass'y (B03)

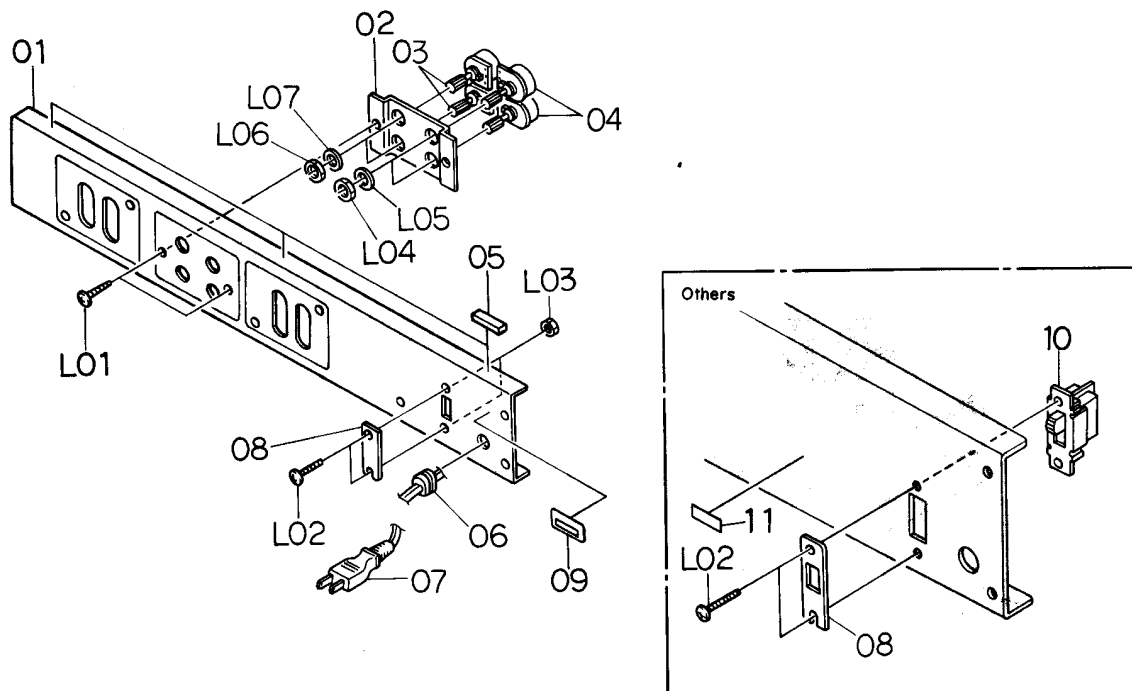

Fig. 6.6

Schematic Ref. No.	Part No.	Description	Q'ty	Schematic Ref. No.	Part No.	Description	Q'ty
B03	HA04165A	Rear Panel Ass'y (U.S.A. & Canada)	1	11	0M03794A	Voltage Seal 100 V (Japan)	1
	HA04164A	Rear Panel Ass'y (Japan)	1		0M03955A	Voltage Seal 120V/220-240V (Others)	1
	HA04168A	Rear Panel Ass'y (Others)	1		0M03797A	Voltage Seal 240V (UK & Australia)	1
	HA04167A	Rear Panel Ass'y (UK)	1		0M03796A	Voltage Seal 220V (220V Class 2)	1
	HA04166A	Rear Panel Ass'y (220V Class 2)	1	-	0M04279A	Serial Number Plate	1
	HA04170A	Rear Panel Ass'y (Australia)	1	-	0M03458B	Pass Label	1
		Serial No.: F10301001 -		L01	0E00860A	BT Screw M3x6 Philips Binding Head (Black Chromate)	2
01	0J04388A	Rear Panel	1	L02	0E00593A	Screw M3x6 Philips Binding Head (Bronze)	2
02	0J04422A	Volume Holder	1	L03	0E00507A	Nut Hex. M3	2
03	0B07311A	Volume 10K (B)	2	L04	-	Volume Nut	(1)
04	0B07312A	Volume 50K (B)	2	L05	-	Volume Washer	(1)
05	0H03960A	Cushion	3	L06	-	Volume Nut	(1)
06	0B08037U	Cord Bushing (U.S.A., Canada, Japan, Others, 220V Class 2 & Australia)	1	L07	-	Volume Washer	(1)
	0B08351A	Cord Bushing (UK)	1				
07	0B08533A	Power Cord (U.S.A., Canada & Others)	1				
	0B08219B	Power Cord (Japan)	1				
	0B08348A	Power Cord (UK)	1				
	0B08093U	Power Cord (220V Class 2)	1				
	0B05241A	Power Cord (Australia)	1				
08	0J03663C	Switch Cover C (U.S.A., Canada, Japan & 220V Class 2)	1				
	0M03946A	Voltage Selector Lock Plate (Others)	1				
09	0M04269A	Rating Label	1				
10	0B07092U	Voltage Selector (Others)	1				

7. BLOCK DIAGRAM

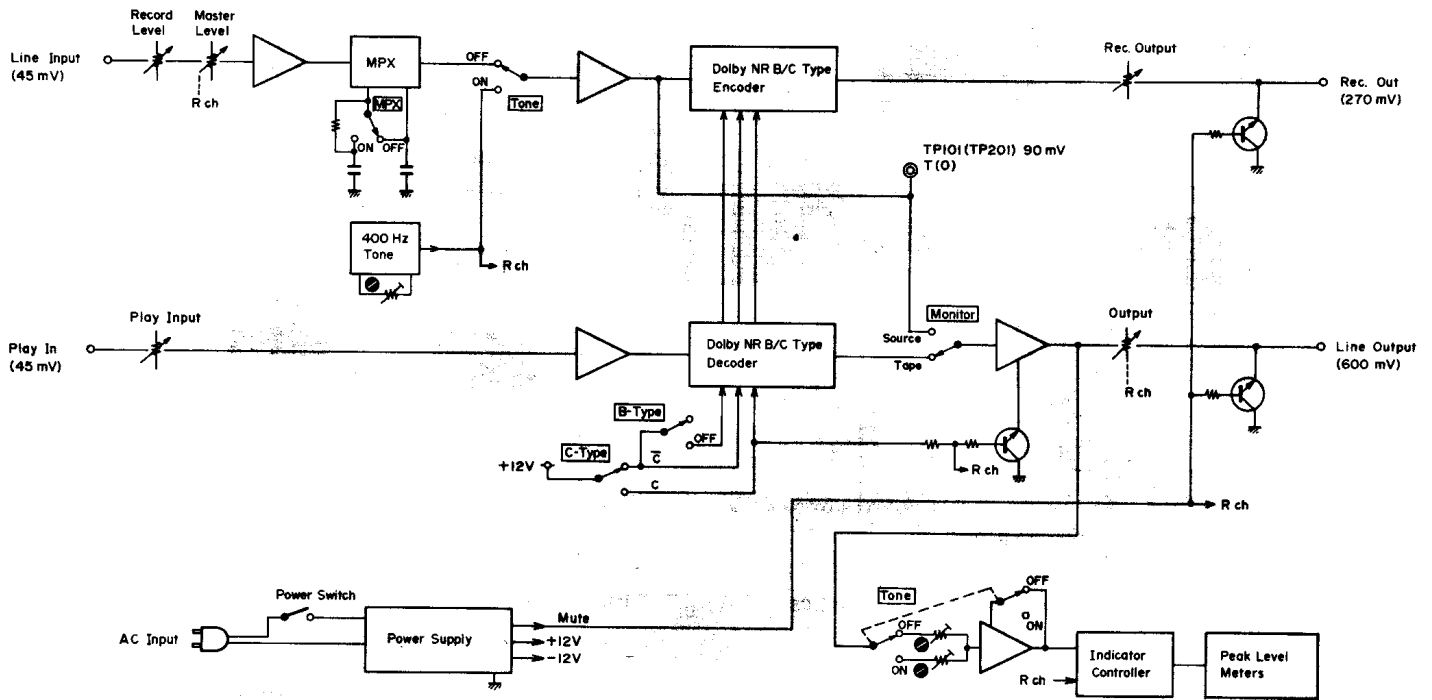

Fig. 7

8. PERFORMANCE DATA

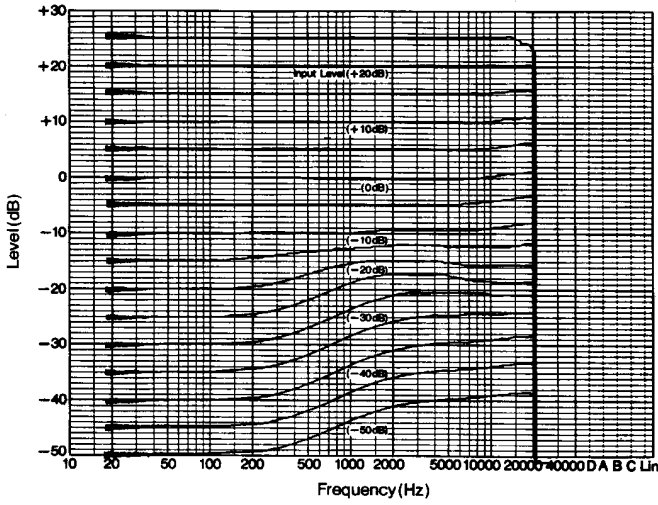

Fig. 8.1 Dolby NR B-Type Encode Characteristics (Level vs. Frequency)

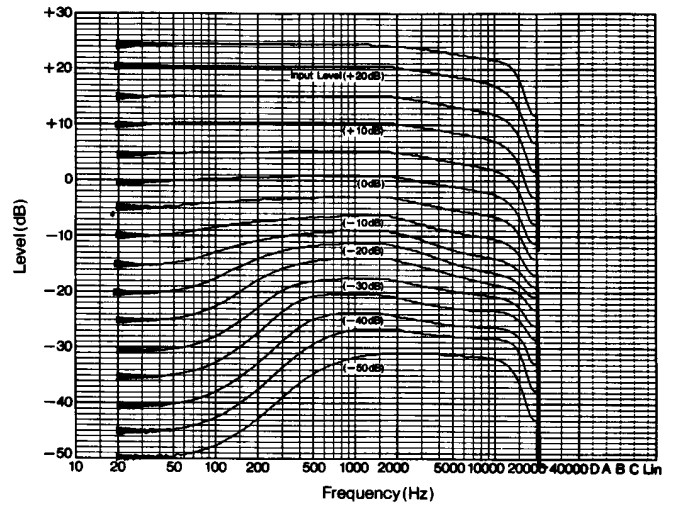

Fig. 8.2 Dolby NR C-Type Encode Characteristics (Level vs. Frequency)

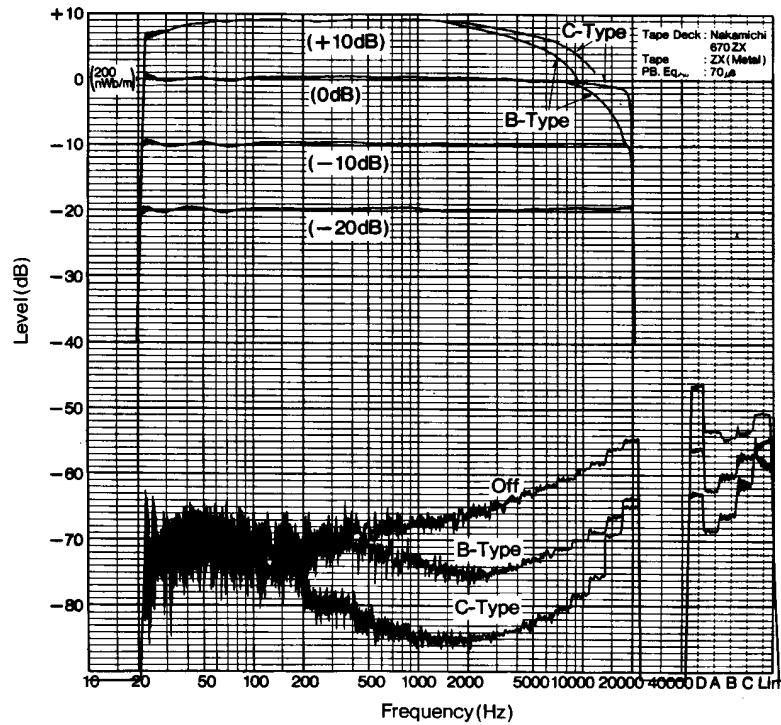

Fig. 8.3 Frequency Response/Noise Spectrum Analysis

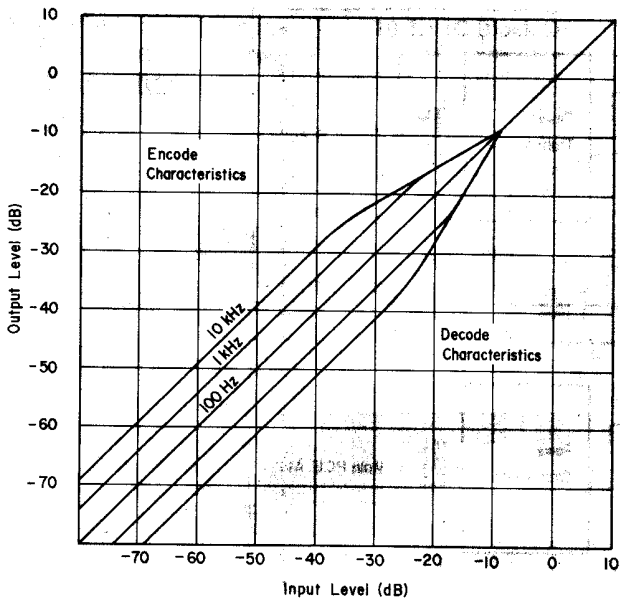

Fig. 8.4 Dolby NR B-Type Encoding and Decoding Characteristics

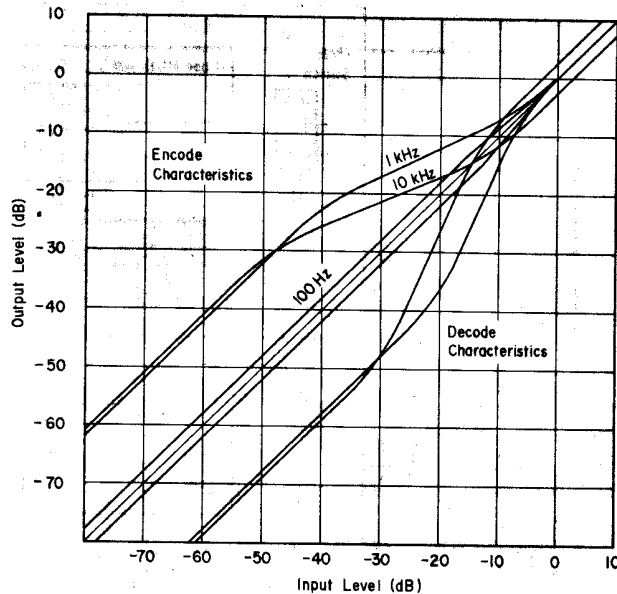

Fig. 8.5 Dolby NR C-Type Encoding and Decoding Characteristics

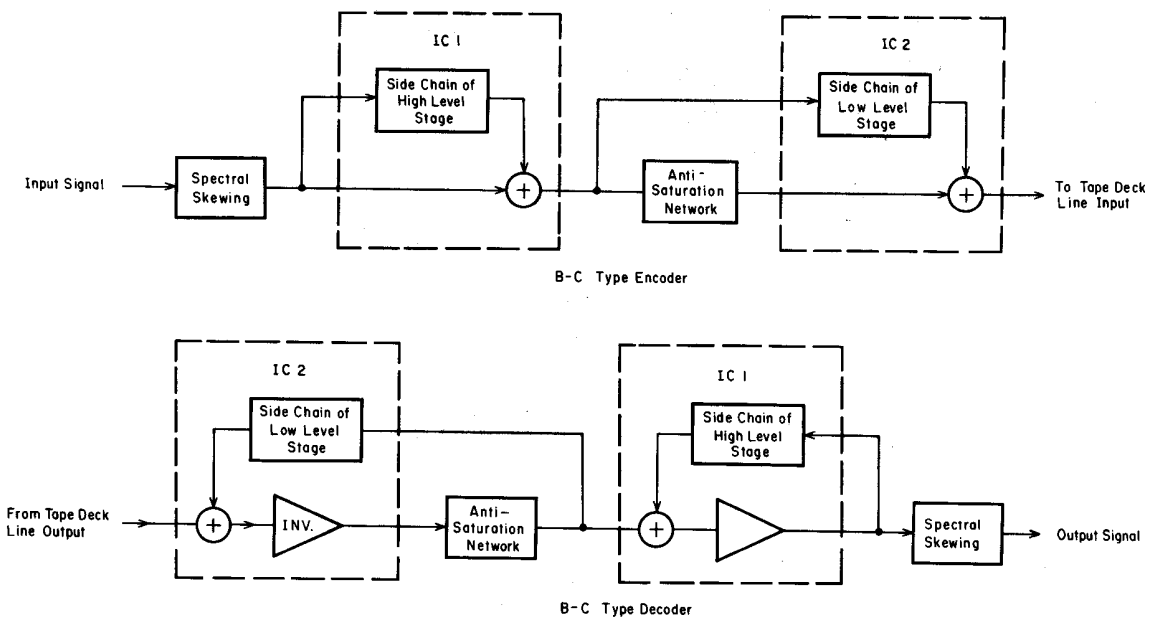

Fig. 8.6 Dolby NR B-C Type Encoder/Decoder Block Diagram

NR-200

9. WIRING DIAGRAM

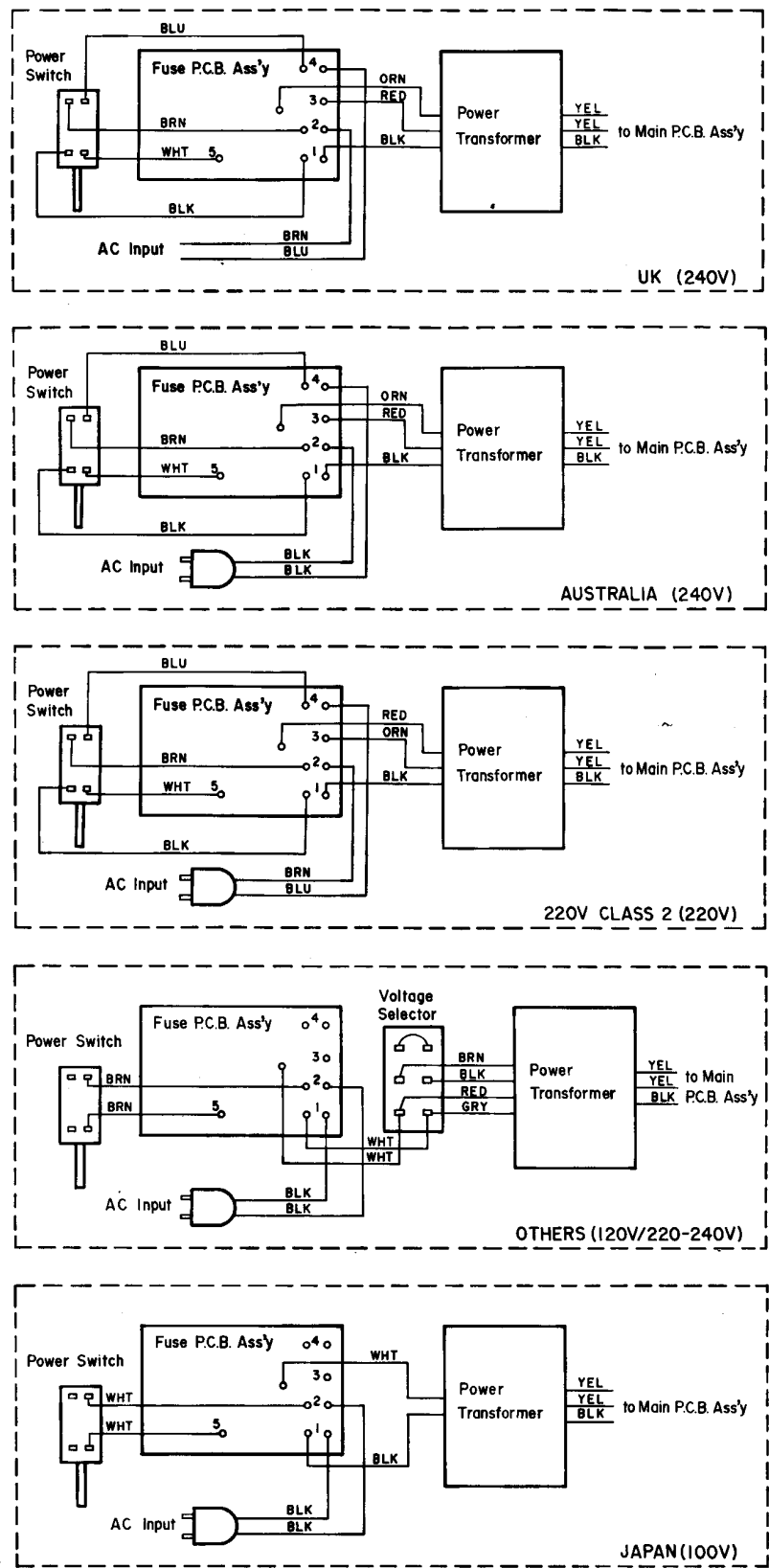

Fig. 9.1

Note: Table of wire colors:
 BLK - Black ORN - Orange
 BLU - Blue GRY - Gray
 GRN - Green BRN - Brown
 RED - Red YEL - Yellow
 WHT - White VIO - Violet

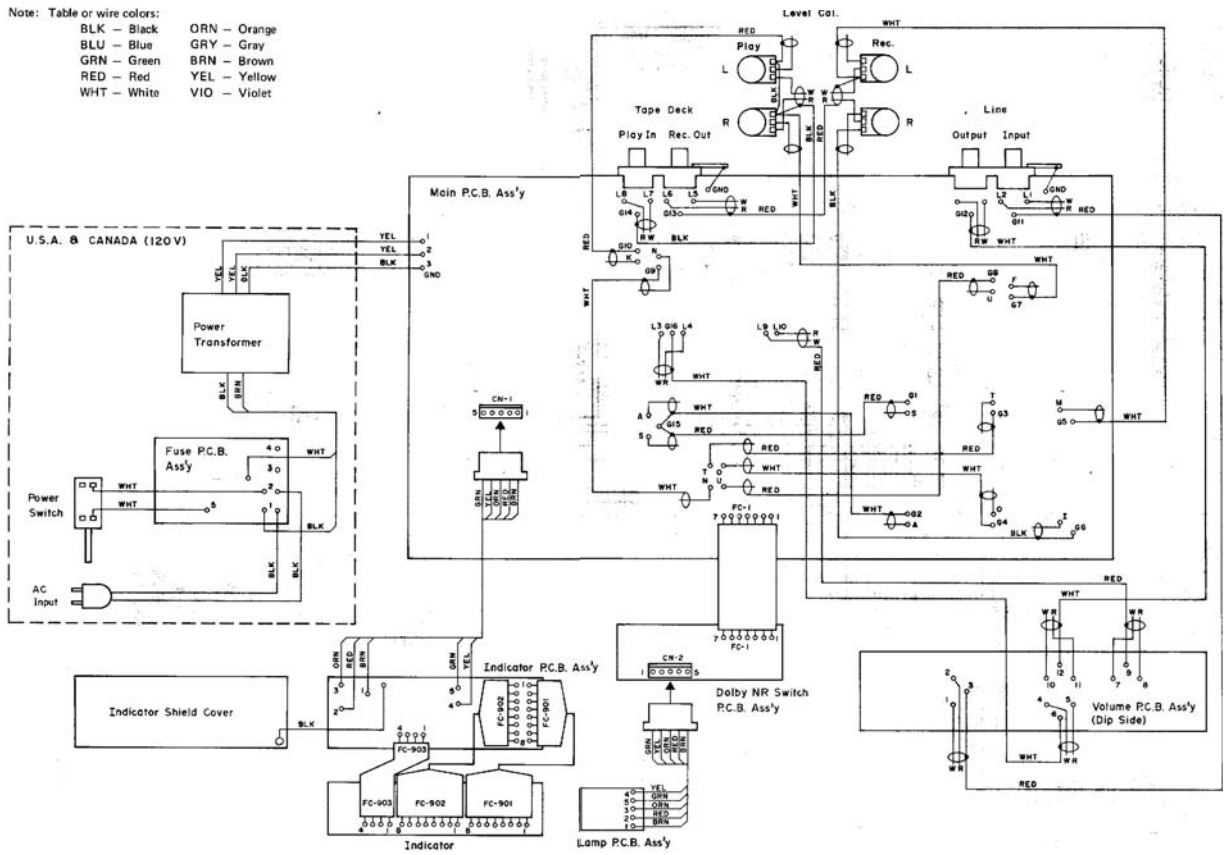

Fig. 9.2

10. SCHEMATIC DIAGRAM

10.1. IC Block Diagrams

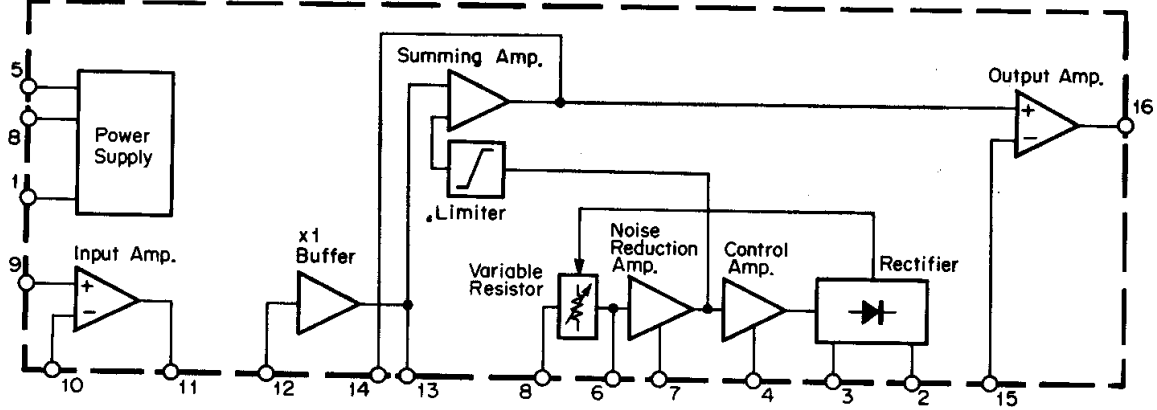

Fig. 10:1 Dolby NR IC μ A7300PC

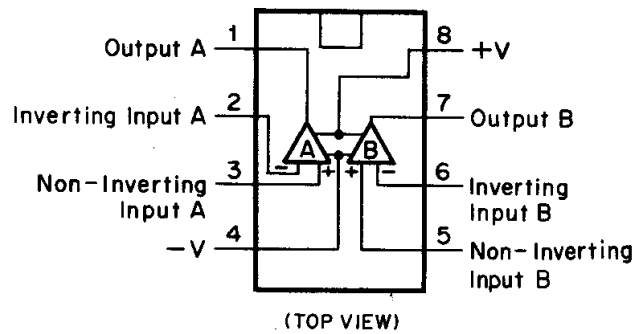

Fig. 10.2 OP Amp. IC 4558, 4556

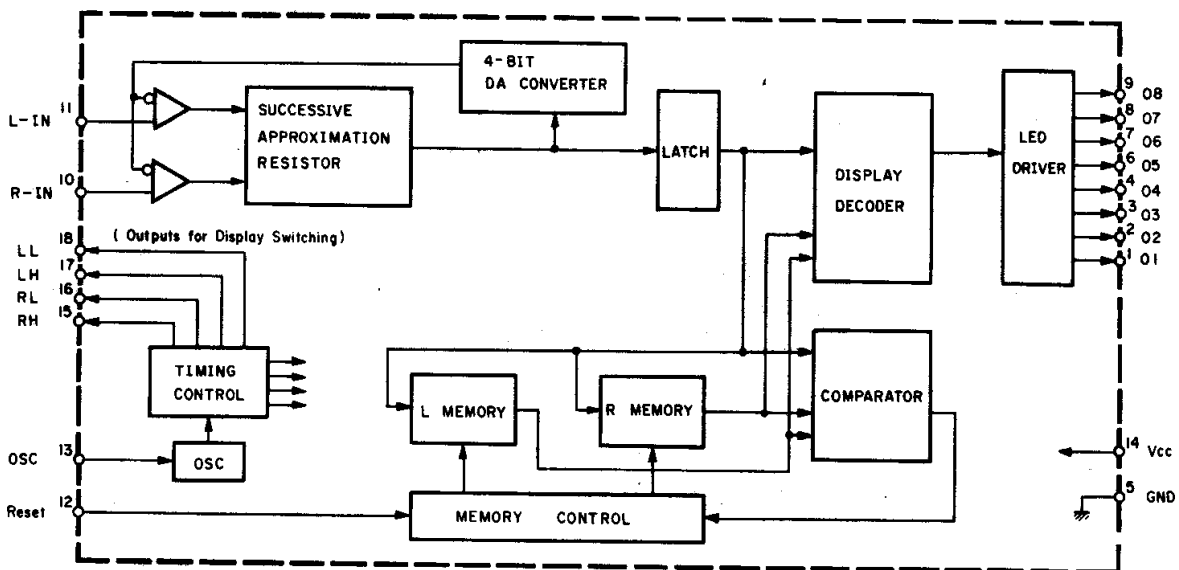
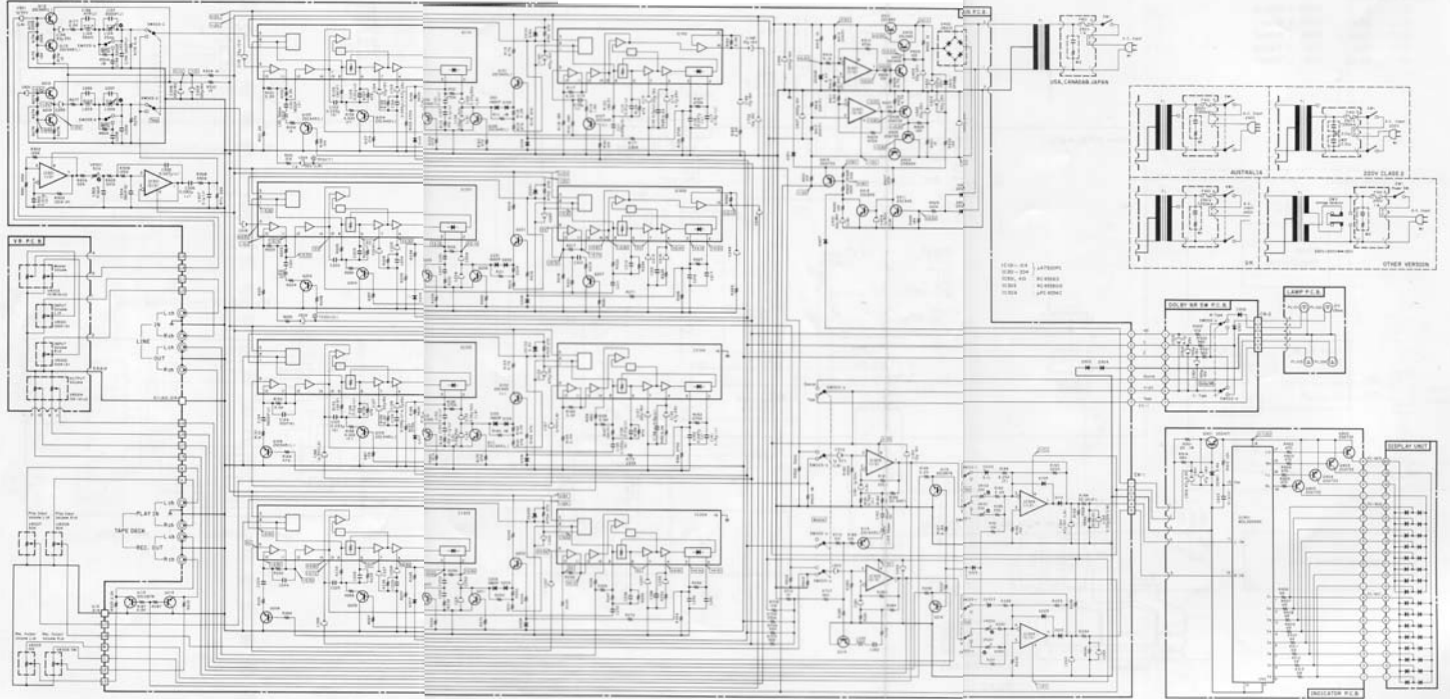

Fig. 10.3 Level Meter Control IC MSL9350RS

10.2. Schematic Diagram



11. SPECIFICATIONS

Power Source	100, 120, 120/220-240, 220 or 240 V AC 50/60 Hz (according to country of sale)
Power Consumption	27 W max.
Noise Reduction Principle	Sliding Band
Number of Channels	4 (to provide simultaneous record/playback)
Noise Reduction B-Type NR	10 dB (above 2 kHz)
C-Type NR	Approx. 18 dB (1 kHz) Approx. 20 dB (2–8 kHz)
Frequency Response	20 Hz–20 kHz \pm 1 dB
Total Harmonic Distortion	Less than 0.1% (at 400 Hz, reference level 0 dB)
Encoder Input	45 mV 50 k ohms (Line Input)
Output	270 mV 2.2 k ohms (to Tape Deck's Line Input)
Decoder Input	45 mV 50 k ohms (from Tape Deck's Line Output)
Output	600 mV 2.2 k ohms (Line Output)
Dimensions	482(W) x 71.5(H) x 268(D) mm 19(W) x 2-13/16(H) x 10-35/64(D) inches
Approximate Weight	5.5 kg 12 lb. 2 oz

- Specifications and appearance design are subject to change for further improvement without notice.
- Dolby NR under license from Dolby Laboratories Licensing Corporation.
- The word "DOLBY" and the Double-D-Symbol are trademarks of Dolby Laboratories Licensing Corporation.

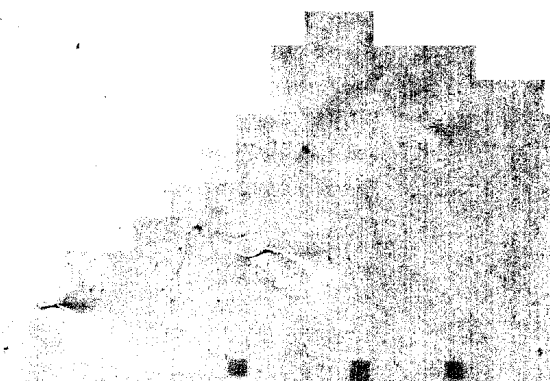

Service Manual

Nakamichi NR-200

Nakamichi Corporation

1-153 Suzukicho, Kodaira, Tokyo
Phone: (0423) 42-1111
Telex: 2832610 (NAKAM J)
Cable: NAKAMICHI KOKUBUNJI

Nakamichi U.S.A. Corporation

220 Westbury Avenue
Carle Place, N.Y. 11514
Phone: (516) 333-5440

1101 Colorado Avenue
Santa Monica, Calif. 90401
Phone: (213) 451-5901
Telex: 652429 (NAKREI SNM)