

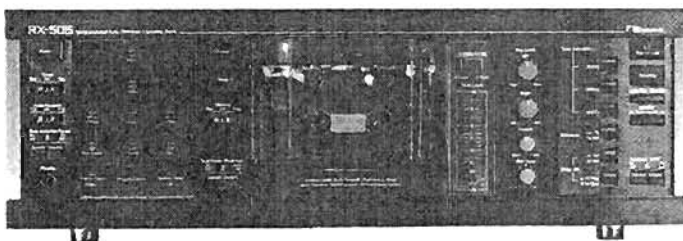

Service Manual

Nakamichi RX-505 RX-505E

Unidirectional Auto Reverse
Cassette Deck



CONTENTS

1.	General	2
2.	Mechanical Adjustments	2
2. 1.	Preparation for Adjustment	2
2. 2.	Mechanism Control Cam Adjustment	3
2. 3.	Reel Motor Speed Adjustment in Play Mode	3
2. 4.	Record Head and Playback Head Tilt Adjustment	4
2. 5.	Head Base Stroke Adjustment	5
2. 6.	Erase Head Stroke Adjustment and Tape Guide Height Check	5
2. 7.	Erase Head Height and Tilt Adjustment	6
2. 8.	Back Tension Adjustment	6
2. 9.	Playback Head and Record Head Height Adjustment and Azimuth Alignment	7
2. 10.	Record Head Stroke Adjustment	7
2. 11.	Tape Travelling Adjustment	8
2. 12.	Flywheel Holder Adjustment	8
2. 13.	Tape Speed Adjustment	9
2. 14.	Slide Base Position Adjustment	9
2. 15.	Lubrication	9
3.	Parts Location for Electrical Adjustment	10
4.	Electrical Adjustments and Measurements	11
4. 1.	Adjustment and Measurement Instructions	11
4. 2.	Playback Frequency Response Adjustment	13
4. 3.	Dolby NR Circuit Check	14
5.	Mechanism Ass'y and Parts List	15
5. 1.	Synthesis	15
5. 2.	Front Panel Ass'y (A01)	16
5. 3.	Chassis Ass'y (A02)	17
5. 4.	Front Panel Escutcheon L Ass'y (B01)	18
5. 5.	Front Panel Escutcheon R Ass'y (B02)	19
5. 6.	Rear Panel Ass'y (B03)	19
5. 7.	Upper Angle Ass'y (B04)	20
5. 8.	Cover Plate Ass'y (B05)	20
5. 9.	Synthesis Mechanism Ass'y (B06)	21
5. 10.	Lid Cover Ass'y (C01)	21
5. 11.	RN Mechanism Ass'y (D01)	22
5. 12.	Mechanism Ass'y RX505 (D02)	22
5. 13.	Motor Holder Ass'y (E01)	22
5. 14.	Slide Chassis Ass'y (E02)	23
5. 15.	Main Chassis Ass'y (E03)	23
5. 16.	Sub Mechanism Ass'y (F01)	24
5. 17.	Record Protector Switch Ass'y (G01)	24
5. 18.	Flywheel Holder Ass'y (H01)	24
5. 19.	Sub Mechanism Chassis Ass'y (H02)	25
5. 20.	Lock Arm L Ass'y (H03)	25
5. 21.	Lock Arm R Ass'y (H04)	25
5. 22.	Main Mechanism Chassis Ass'y (H05)	26
5. 23.	Head Mount Base Ass'y (I01)	26
5. 24.	Supply Pressure Roller Ass'y (I02)	27
5. 25.	Take-up Pressure Roller Ass'y (I03)	27
5. 26.	Head Base Ass'y (I04)	27
5. 27.	P-8L Playback Head Ass'y (J01)	27
5. 28.	R-8L Record Head Ass'y (J02)	27
6.	Mounting Diagrams and Parts List	28
6. 1.	Power Switch P.C.B. Ass'y	28
6. 2.	Fuse P.C.B. Ass'y	28
6. 3.	Lid Lamp P.C.B. Ass'y	28
6. 4.	TS Pulse P.C.B. Ass'y	28
6. 5.	Volume P.C.B. Ass'y	29
6. 6.	Indicator P.C.B. Ass'y	29
6. 7.	Switch P.C.B. Ass'y	29
6. 8.	Control P.C.B. A Ass'y	30
6. 9.	Control P.C.B. B Ass'y	31
6. 10.	DC Power Supply P.C.B. Ass'y	32
6. 11.	Dolby NR P.C.B. Ass'y	33
6. 12.	Logic P.C.B. Ass'y	36
6. 13.	Main P.C.B. Ass'y	37
7.	Schematic Diagrams	38
7. 1.	Attention to Servicemen	38

7. 2.	IC Block Diagrams	38
7. 3.	Schematic Diagrams	40
	7.3.1. Amplifier Section	40
	7.3.2. Mechanism Control Section	41
8.	Timing Chart and Eq. Amp. Frequency Response	42
	8. 1. Overall Timing Chart	42
	8. 2. Eq. Amp. Frequency Response	42
9.	Wiring Diagram	43
10.	Block Diagrams	44
	10. 1. Amplifier Section	44
	10. 2. Mechanism Control Section	45
11.	Specifications	46

1. GENERAL

1.1. Voltage Selector

Voltage selector is installed on the rear panel for Other version of the Nakamichi RX-505/RX-505E. This voltage selector can select either 120 V or 220-240 V at customer's disposal.

1.2. Packing Materials and Owner's Manual

<u>Part No.</u>	<u>Description</u>	<u>Q'ty</u>
0F03741A	Outer Carton (U.S.A., Canada, Australia, Others & Japan)	1
0F08745A	Outer Carton (UK & 220V Class 2)	1
0F03778A	Inner Carton (U.S.A., Canada, Australia, Others & Japan)	1
0F03777A	Inner Carton (UK & 220V Class 2)	1
0F03742A	Packing	2
0D04823A	Owner's Manual RX-505 (U.S.A., Canada & Australia)	1
DA03728A	Owner's Manual RX-505/RX-505E (including French statement) (UK, 220V Class 2 & Others)	1
0D04324A	Owner's Manual RX-505 (Japan)	1

2. MECHANICAL ADJUSTMENTS

2.1. Preparation for Adjustment

Load a Gauge into the RX-505 as follows:

(1) Removal of the Cassette Case Ass'y and Cover Plate Ass'y

Refer to Fig. 2.1.

- (a) Remove the Front Panel Ass'y.
- (b) Turn the Power switch to ON.

- (c) Push the Eject/Load button to slide out the Cassette Compartment.
 - (d) Remove F01 (Stopper Ring 3 mm), F02 (Mylar Washer) and F03 (Cassette Case Ass'y).
 - (e) Unfasten two screws F04 and remove F05 (Cover Plate Ass'y).
- Note: Do not miss the parts removed.

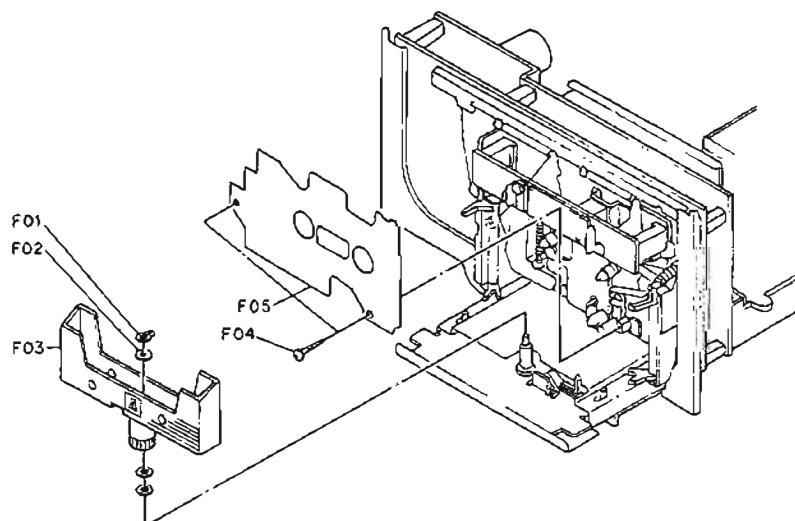

Fig. 2.1

(2) How to Load a Gauge

- (a) Tape the Record Protector switch as shown in Fig. 2.2 to allow easy loading of a Gauge.
- (b) Load a Gauge as follows:
 - 1) Place a Gauge instead of a cassette tape.
 - 2) With pushing the Gauge with your fingers, push the Eject/Load button to load the Gauge.
The Cassette Compartment automatically slides in and then the Lock Arms (Right & Left) secure the Gauge.

(8) After Adjustment

After adjustment, reverse the above steps as follows:

- (a) Push the Eject/Load button to slide out the Cassette Compartment and remove the Gauge.
- (b) Remove the tape of the Record Protector switch.
- (c) Mount the F05 (Cover Plate Ass'y) and F03 (Cassette Case Ass'y).
Note: Mylar washer(s) must be placed on the original places.
- (d) Push the Eject/Load button to slide in the Cassette Compartment.
- (e) Turn the Power switch to OFF.
- (f) Mount the Front Cover.

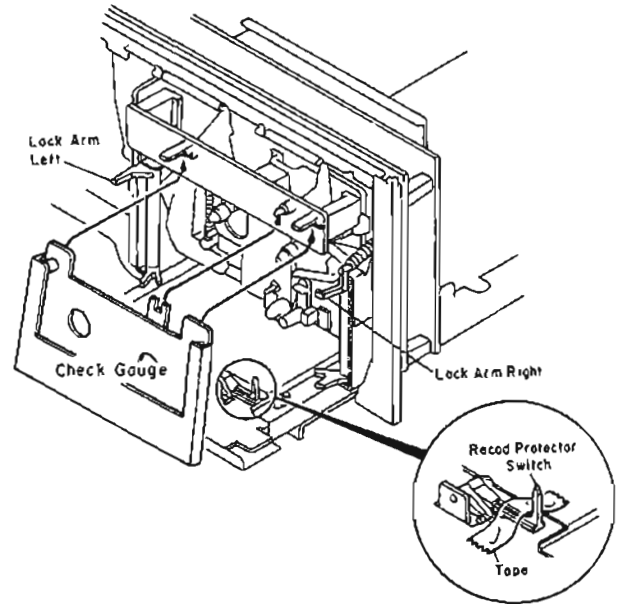

Fig. 2.2

2.2. Mechanism Control Cam Adjustment

(1) Offset Adjustment of Control Motor Driver

- (a) Refer to Fig. 2.3.
Adjust VR602 and VR603 on the Logic P.C.B. Ass'y to locate approximately at the middle of the variable range. Then turn ON the Power switch.
VR602 (for Cam position play)
VR603 (for Cam position stop)
- (b) Press the Stop button to set the cassette deck in Stop mode. Adjust VR603 (for stop) so that the "S" mark on the Cam corresponds to the pointer on the mechanism chassis.
- (c) Press the Play button to set the cassette deck in Playback mode. (Cam will rotate, and the position marked with "PY" comes to the pointer.) Adjust VR602 (for play) so that the "PY" mark on the Cam corresponds to the pointer.
- (d) Repeat above (b) and (c) 2 - 3 times so that the "S" and "PY" marks on the Cam correspond to the pointer accurately in Stop and Playback modes respectively.
(This adjustment is required because the position adjusted by one volume will be slightly changed when the other volume is adjusted.)
- (e) Set the cassette deck in F.F., Pause, or Cue mode by pressing each button.
Check to insure that the pointer is in a range of "F", "PS", or "CU" mark respectively.
- (f) If out of the range, precise adjustment for each position according to "(2) Offset Fine Adjustment of Control Motor Driver" will be required.

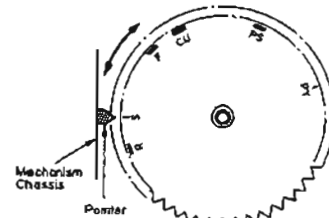

Fig. 2.3

(2) Offset Fine Adjustment of Control Motor Driver

Adjust only if a satisfactory result is not obtained in "(1) Offset Adjustment of Control Motor Driver". This adjustment is made by changing the value of the fixed resistors on the Logic P.C.B. Note: The value of voltage is typical value.

(a) Observation Point of Reference Voltage

Observe the each voltage at the sliding contact of the Cam Control Volume VR608 in Stop, Fast (F.F. or Rew.), Pause and Playback modes.

(b) Reference Voltage

Reference voltage at the sliding contact of VR608 (Cam Control Volume) in each mode is as follows:

Mode	Reference Voltage (Typical Value)
Stop	0 V
Fast (F.F./Rew.)	-2.0 V
Pause	-6.5 V
Play	-9.1 V

2.0 V ± 0.25 V
2.6 V ± 0.4 V

(c) Resistors for Adjustment

Mode	Ref. No.	Typical Value
Fast (F.F./Rew.)	R655	22 kΩ
Pause	R649	76.8 kΩ (F)
Play	R653	10 kΩ

(d) Adjustment Procedures

- 1) Set the cassette deck in Stop mode, then check to insure that the voltage at the sliding contact of VR608 is 0 V (±0.3 V).
- 2) Set the cassette deck in F.F. mode, then adjust the value of R655 so that the voltage at the sliding contact of VR608 will become lower by 2.0 V (±0.25 V) than in Stop mode.
- 3) Press the Pause button to set the cassette deck in Pause mode. Adjust the value of R649 to obtain -6.5 V (±0.4, -0.15 V) at the sliding contact of VR608.
- 4) Set the cassette deck in Playback mode, then adjust the value of R653 so that the voltage at the sliding contact of VR608 will become lower by 2.6 V (±0.4 V) than in Pause mode.

2.3. Reel Motor Speed Adjustment in Play Mode

- (1) Connect a DC voltmeter to TP602 and GND on the Logic P.C.B. Ass'y.
- (2) Without loading a cassette tape, set the cassette deck in Play mode.
- (3) Adjust VR604 on the Logic P.C.B. Ass'y to obtain -4 V on the DC voltmeter.

2.4. Record Head and Playback Head Tilt Adjustment

Note: On items 2.4 — 2.10, refer to Fig. 2.4 flow chart. Refer to Figs. 2.5 and 2.6.

- (1) Load a Tilt Check Gauge M-9039 (DA09039B) in the cassette deck.
- (2) Clip the grounding terminal of the Tilt Check Gauge with one end of the cord with clip, and the chassis of the cassette deck with the other end.
- (3) Remove both of the Height Gears.
- (4) Set the cassette deck in Play mode. Check to insure whether the Beacons Playback Head "Upper" or "Lower" and Record Head "Upper" or "Lower" are illuminating. In order not to give damages onto the head surfaces, push both of slide knobs of the Gauge to the direction of arrow marks, then return them to the original place to be in contact with record head and playback head surfaces after Play mode is securely locked.
- (5) Check to insure freedom from contact between the Gauge and pad lifter.
- (6) Beacon Playback Head "Lower" will light on when height adjustment screw (P) turned clockwise but Playback Head "Upper" when counterclockwise. Adjust so that both "Upper" and "Lower" will light on even when you move the slide knob to the direction of an arrow mark and then return it to the original place.
- (7) Same procedures will apply to the Beacons Record Head "Upper" and "Lower", except for the height adjustment screw (R).

- (8) Set the cassette deck in Stop mode and fit both of the serrated Height Gears. Then set the cassette deck again in Play mode and insure all of the 4 Beacons are illuminating. If not, (3) through (7) will have to be repeated till satisfactory results are obtained.

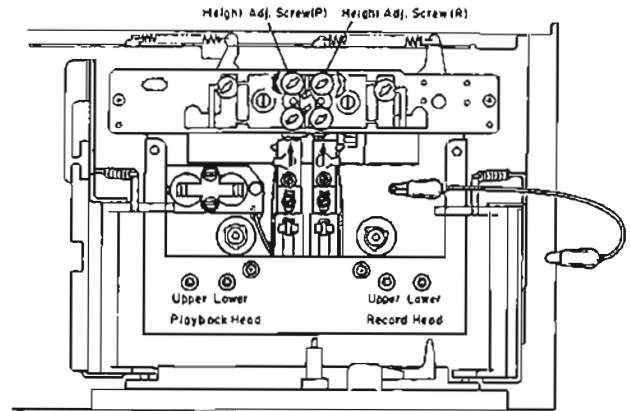

Fig. 2.5

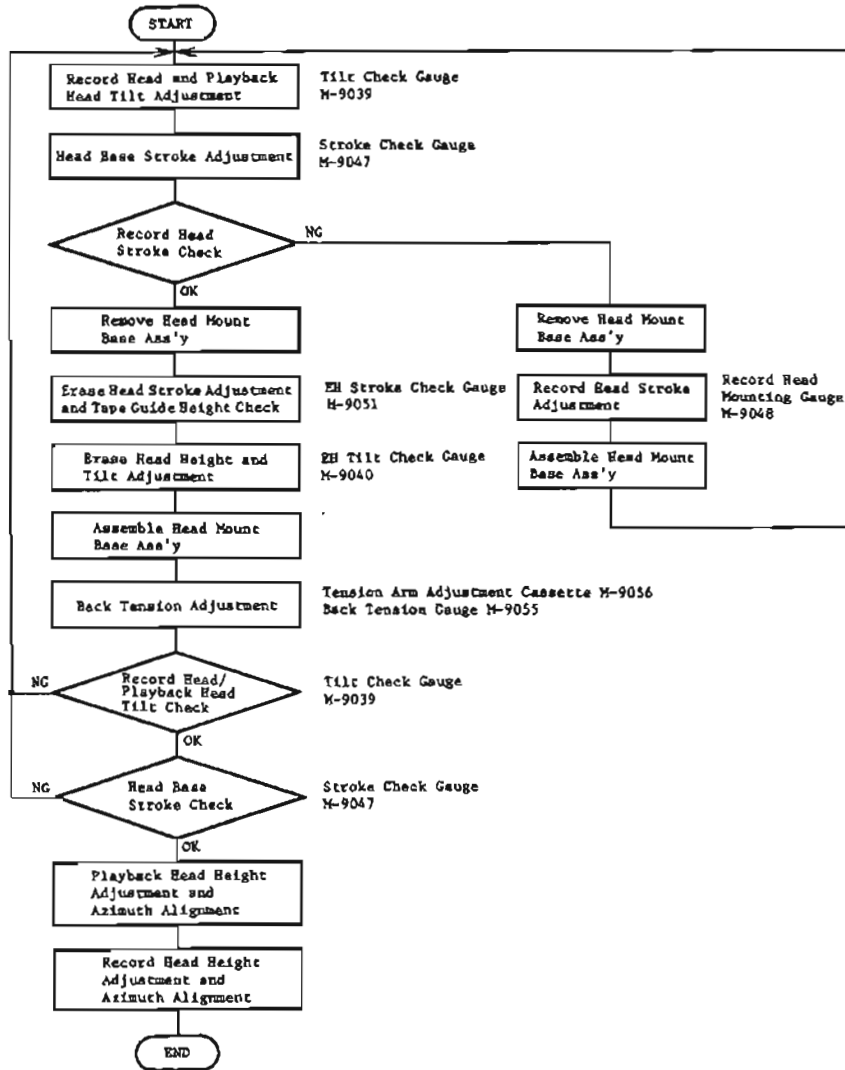

Fig. 2.4

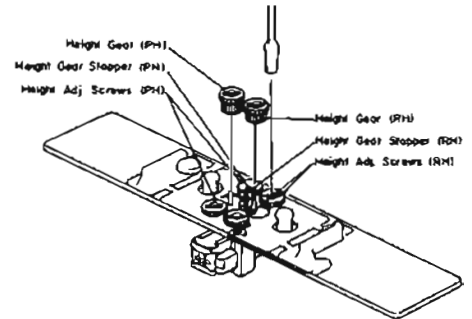

Fig. 2.6

2.5. Head Base Stroke Adjustment

Refer to Fig. 2.7.

Note: Before you conduct this adjustment, adjust with a "Tilt Check Gauge" to insure freedom from tilt on the playback head and record head.

- (1) Head Base Stroke Adjustment in Play Mode
 - (a) Load a Stroke Check Gauge M-9047 (DA09047B) in the cassette deck.
 - (b) Move Record Head Indicator and Playback Head Indicator to the direction of arrow mark "A" with your finger tip and then set the cassette deck in Play mode. Then slowly release the Indicators and insure whether each of the Indicators is in contact with record and playback heads.
 - (c) Check to insure whether the "P" pointer on the Playback Head Indicator locates between the 2 lines on the Indicator Plate.
 - (d) If the playback head stroke is noted to be misaligned, adjustment can be made by moving the stroke adjuster assembled in the head base assembly (either forwardly or backwardly).
 - (e) Check to insure whether the "P" pointer on the Playback Head Indicator locates between the 2 lines on the Record Head Indicator, thus check can be made on record head stroke.
 - (f) If the record head stroke is noted to be misaligned, adjustment can be made with a Record Head Mounting Gauge M-9048 (DA09048B).
- (2) Head Base Stroke Adjustment in Cue Mode
 - (a) Load a Stroke Check Gauge M-9047 (DA09047B) in the cassette deck.
 - (b) Move Record Head Indicator and Playback Head Indicator to the direction of arrow mark "A" with your finger tip and then set the cassette deck in Cue mode. Then slowly release the Indicators and insure whether each of the Indicators is in contact with record and playback heads.
 - (c) Check to insure whether the "C" pointer on the Playback Head Indicator locates between the 2 lines on the Indicator Plate.
 - (d) If the playback head stroke is noted to be misaligned, adjust VR601 on the Logic P.C.B. Assy till satisfactory results are obtained.
 - (e) After completion of the Head Base Stroke Adjustment, check to insure accuracy of the Head Base Stroke Adjustment in Play mode. If the above are inaccurate, items (1) and (2) will have to be repeated till satisfactory results are obtained.

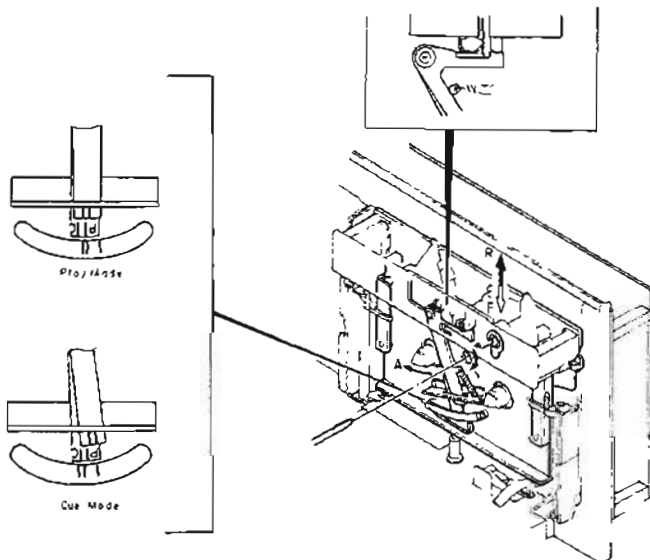

Fig. 2.7

2.6. Erase Head Stroke Adjustment and Tape Guide Height Check Remove the Head Mount Base Assy. Refer to Figs. 2.8 and 2.9.

- (1) Erase Head Stroke Adjustment
 - (a) Load an EH Stroke Check Gauge M-9051 (DA09051B) in the cassette deck.
 - (b) Set the cassette deck in Play mode, thus check can be made on erase head stroke through the EH Stroke Indicator.
 - (c) Check to insure whether the erase head surface is aligned with red line on the EH Stroke Indicator. If not, adjust the erase head stroke by loosening 2 screws A that assemble erase head and erase head plate.
 - (d) After completion of adjustment, 2 pcs. of screws shall be locked with lock tight paint.
- (2) Supply Tape Guide Height Check
 - (a) Load an EH Stroke Check Gauge M-9051 (DA09051B) in the cassette deck.
 - (b) Set the cassette deck in Play mode.
 - (c) Slide the Supply Tape Guide Check Bar down against the supply tape guide, and check to insure that the Supply Tape Guide Check Bar is accepted by the supply tape guide.
- (3) Take-up Tape Guide Height Check
 - (a) Load an EH Stroke Check Gauge M-9051 (DA09051B) in the cassette deck.
 - (b) Set the cassette deck in Play mode.
 - (c) Slide the Take-up Tape Guide Check Bar down against the take-up tape guide, and check to insure that the Take-up Tape Guide Check Bar is accepted by the take-up tape guide.

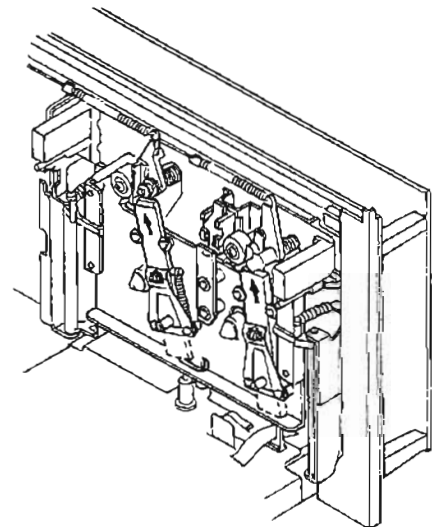

Fig. 2.8

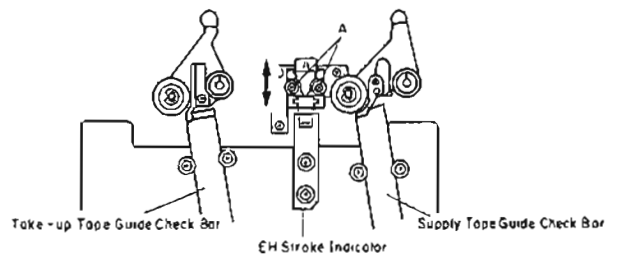

Fig. 2.9

2.7. Erase Head Height and Tilt Adjustment

Refer to Figs. 2.10 and 2.11.

- (1) Remove Head Mount Base Ass'y.
- (2) Load an EH Tilt Check Gauge M-9040 (DA09040B) in the cassette deck.
- (3) Set the cassette deck in Stop mode.
- (4) Check to insure whether one of the 3 Beacons is illuminating. Look down the mirror as shown by an arrow mark and slowly turn the Screw "Height" counterclockwise (or clockwise) so that the two horizontal lines on the mirror will become superposed on the line (in different color) of the erase head, and check to insure whether Beacon "1" is illuminating.
- (5) Turn Screw "Tilt" counterclockwise (or clockwise) to light on Beacon "2". Excessive turning will cause the Beacon "1" to light off. Adjustments of Screw "Tilt" will therefore be conducted till both of the Beacons "1" and "2" illuminate.
- (6) Turn Screw "Azimuth" counterclockwise (or clockwise) to light on Beacon "3". Excessive turning will cause either Beacon "1" or "2" to light off, and therefore adjust Screw "Azimuth" until all of the 3 Beacons "1", "2" and "3" illuminate.
- (7) Check to insure whether the horizontal line on the mirror corresponds to that on the erase head. If not, (4) through (7) will have to be repeated till satisfactory results are obtained.
- (8) After completion of adjustment, 3 pcs. of screws shall be locked with lock tight paint.

Note: Before use of this gauge, check to insure freedom from dust or dirt, or overflow in the groove of the erase head surface.

2.8. Back Tension Adjustment

Refer to Figs. 2.12 - 2.15.

- (1) Load a Tension Arm Adjustment Cassette (DA09056B) in the cassette deck referring to Fig. 2.12.
- (2) Set the cassette deck in Play mode.
- (3) Bend the Back Tension Arm with pliers so that the gap between the Cassette Holding Spring assembled on the Head Base Ass'y and the Back Tension Arm becomes 0.5 mm as shown in Fig. 2.13. Do not bend the top of the Back Tension Arm.
- (4) Set the cassette deck in Stop mode, and remove the Tension Arm Adjustment Cassette (DA09056B), then set the cassette deck in Cue mode. In Cue mode, check to insure that the gap is found between the Supply Reel Hub B Ass'y and the Felt of Back Tension Ass'y as shown in Fig. 2.14.
- (5) Load the Back Tension Gauge (DA09056B) in the cassette deck.
- (6) Set the cassette deck in Play mode and read the torque value of Back Tension Gauge. If the value is in a range of 5 g-cm to 9 g-cm, adjustment is not necessary. If not, change the installation point of the Back Tension Spring as shown in Fig. 2.15, and obtain the torque of 6 g-cm to 8 g-cm range.

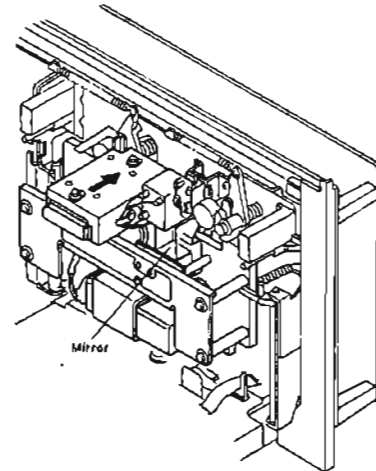

Fig. 2.10

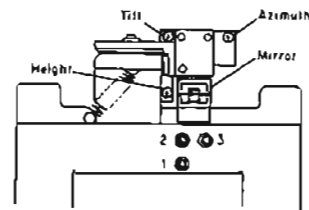

Fig. 2.11

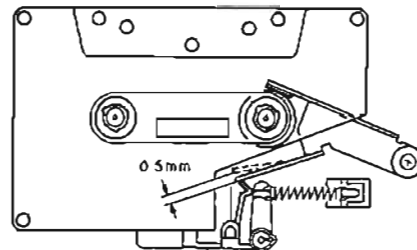

Fig. 2.13

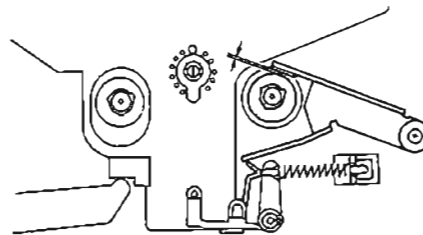

Fig. 2.14

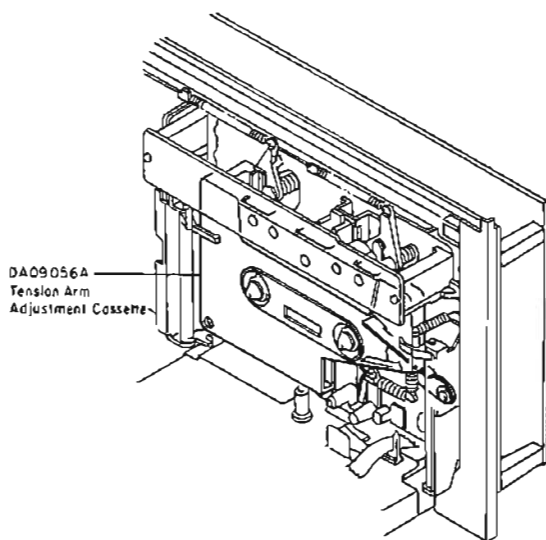

Fig. 2.12

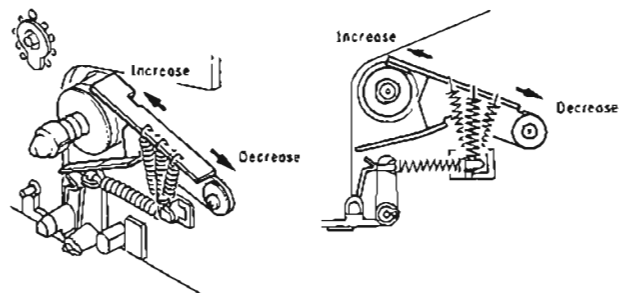

Fig. 2.15

2.9. Playback Head and Record Head Height Adjustment and Azimuth Alignment

(1) Playback Head Height Adjustment and Azimuth Alignment Refer to Fig. 2.16.

- (a) Set the Monitor switch to Tape, then connect a VTVM to the Output Jacks.
- (b) Load a 1 kHz Track Alignment Tape (DA09007B), then set the cassette deck in Play mode.
- (c) Turn the PH Height Gear until the outputs of both channels become minimum.
- (d) Load a 15 kHz Azimuth Tape (DA09004B), then set the cassette deck in Play mode.
- (e) Turn the PH Azimuth Alignment Screw until the outputs of both channels become maximum.
- (f) Repeat above steps (b) through (e) one or two times to obtain optimum performance.

(2) Record Head Height Adjustment and Azimuth Alignment Refer to Figs. 2.16 and 2.17.

- (a) Set the cassette deck in Stop mode.
- (b) Set the Monitor switch to Tape, Eq. switch to 70 μ s and Tape Selector switch to SX.
- (c) Load a reference SX tape (DA09026B) and connect a VTVM to Output Jacks.
- (d) Feed in 400 Hz (0 dB) to the Input Jacks.
- (e) Set the cassette deck in Record and Play mode and turn the RH Height Gear until the outputs of both channels become maximum.
- (f) Feed in 15 kHz (-20 dB) to the Input Jacks and turn the RH Azimuth Alignment Screw until the outputs of both channels become maximum.

- (g) Repeat (d) to (f) one or two times to obtain optimum performance.

- (h) After completion of the above adjustments, feed in 400 Hz (0 dB) and set the cassette deck in Record and Play mode. Record 400 Hz tone to the same portion of both sides A and B of the tape.

- (i) Immerse the recorded tape in a magnetized developing solution. In turn, check to insure that the recording head tracks across the center are separated with a distance of 0.55 to 0.75 mm (typically 0.65 mm) as illustrated in Fig. 2.17.

Note: Liquid for tape magnetized development solution "MAGNA-SEE SOUND CRAFT a product of CBS RECORDS a division of Columbia Broadcasting System, Inc., Danbury, Conn. 06810 U.S.A., or equivalent".

After development, clean the tape otherwise pressure rollers and heads will become dirty.

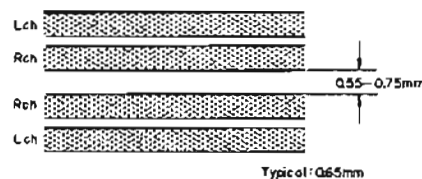

Fig. 2.17

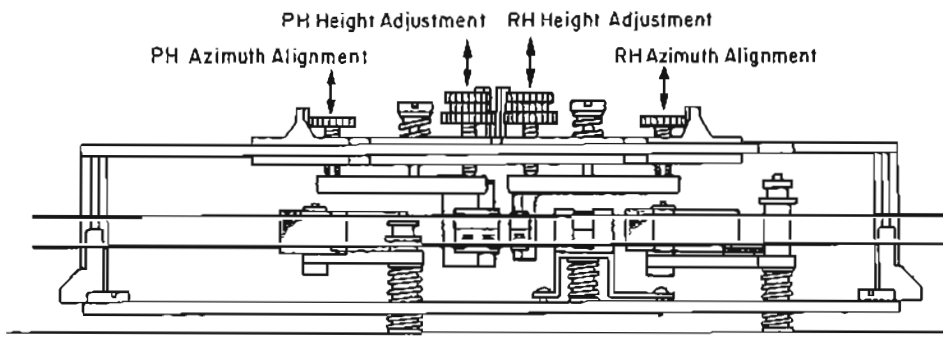

Fig. 2.16

2.10. Record Head Stroke Adjustment

Refer to Figs. 2.18 and 2.19.

Note: This adjustment will be required only to insure freedom from misalignment of the record head stroke in the record head stroke check mode.

- (1) Check the accuracy of the record head stroke.
- (2) Remove Head Mount Base Assy.
- (3) Remove the record head assembly.
- (4) Adjustment of Record Head Mounting Gauge M-9048 (DA0-9048B)
 - (a) Mount the Block B onto the Mounting Gauge Plate.
 - (b) Loosen the 2 screws fixing the Block A.
 - (c) As shown in Fig. 2.18, hold the Gauges (3.05 mm and 0.1 mm thickness) between the Block A and Block B, and fix the Block A with screws, pushing the Block A to the 2 guide pins.
- (5) Remove the Block B from the Mounting Gauge Plate.
- (6) As shown in Fig. 2.19, mount the record head assembly onto the Mounting Gauge Plate, then check the location of the record head surface. (If record head touches the Block C, loosen 2 pcs. of screws that assemble record head and record head plate, then place the record head assembly onto the Plate.)
- (7) Remove the record head assembly from the Mounting Gauge Plate.
- (8) Readjustment of Record Head Mounting Gauge M-9048 (DA09048B)

- (a) Mount the Block B onto the Mounting Gauge Plate.
- (b) Loosen the 2 screws fixing the Block A.

- (c) As shown in Fig. 2.18, hold the Gauges (3.05 mm and either one of 0.05, 0.15, 0.2, 0.25, 0.3 or 0.35 mm thickness) between the Block A and Block B, and fix the Block A with screws, pushing the Block A to the 2 guide pins.

- (9) Remove the Block B from the Mounting Gauge Plate.
- (10) Mount the record head assembly onto the Mounting Gauge Plate.

- (11) As shown in Fig. 2.19, loosen 2 pcs. of screws that assemble record head and record head plate. As the location of the Block A is secured by the item (8)-(c), push the record head to the directions A and B, then tighten 2 pcs. of screws.

- (12) Check to insure freedom from gap between the Block C and record head surface, then tighten the 2 pcs. of screws on the record head assembly with lock tight paint.

- (13) Remove the record head assembly from the Mounting Gauge Plate.

- (14) Assemble the record head assembly to the head mount base assembly.

- (15) Assemble the head mount base assembly to the mechanism assembly.

- (16) Check the record head stroke. If the above are inaccurate, items (1) through (16) will have to be repeated till satisfactory results are obtained.

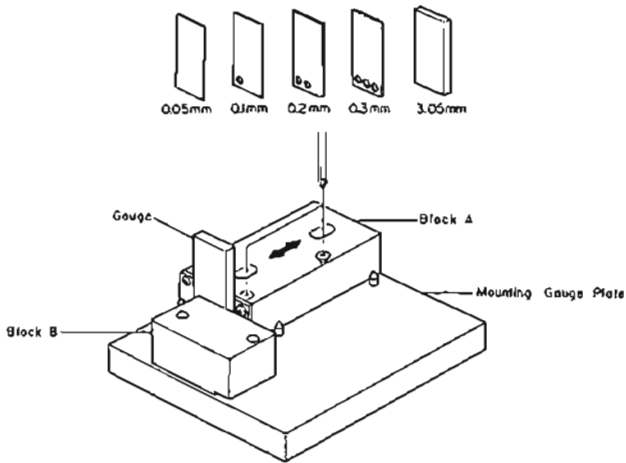

Fig. 2.18

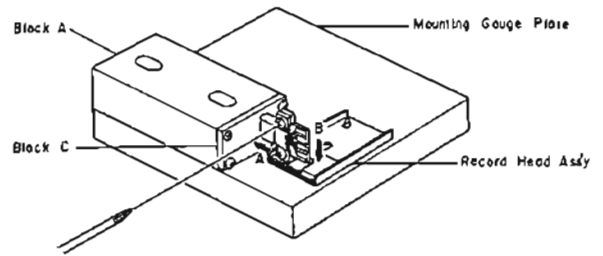

Fig. 2.19

2.11. Tape Travelling Adjustment

Load and playback the Tape Travelling Cassette (DA09071A) and check the following:

- (1) Tape is contact with heads sufficiently.
- (2) Tape waving is small on the heads and pressure rollers.
- (3) Tape is free from waving or slippage from the tape guides.

If either of the above should be noted, adjustment of items 2.4 to 2.10, etc. will be required.

As a case may be, the said waving or slippage may have been caused from defective Supply Pressure Roller Ass'y or Take-up Pressure Roller Ass'y without parallel contact with capstans. If such are noted, the Pressure Roller Assemblies will have to be replaced.

Further, excessively weak take-up torque or strong take-up torque may cause defective tape travelling.

The cassette deck is intended to be an adjustment-free model, however if the similar matters as above should be noted, please replace the Reel Hub Ass'y to obtain appropriate take-up torque.

2.12. Flywheel Holder Adjustment

Refer to Fig. 2.21.

- (1) Tighten the Thrust Screws until the gap between the Flywheel Assemblies and Thrust Screws becomes minimized when both of the Capstan Shafts are moved backwardly and forwardly by hand (the Thrust Springs between the Capstan Flanges and Flywheel Thrust Caps are in a flat state). Excessive tightening of the Thrust Screws however will give damages on the Flywheel Assemblies, to which careful attention is invited.
- (2) Return the Thrust Screws by 1/2 turn.
- (3) Fixing the Thrust Screws with a screwdriver, lock the Lock Nut.
- (4) Apply a quantity of lock tight paint to the Thrust Screws.



Fig. 2.20

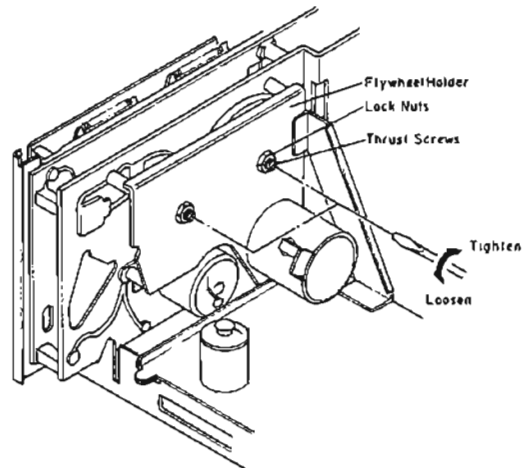

Fig. 2.21

2.13. Tape Speed Adjustment

Refer to Fig. 2.22.

- (1) Remove the Top Cover Ass'y.
- (2) Connect a Frequency Counter to the Output Jack.
- (3) Load a 3 kHz Speed Wow/Flutter Tape (DA09006C) and play it back.
- (4) Adjust the Tape Speed Adjustment Volume (VR501) incorporated in the Capstan Motor to obtain 3,000 Hz on the Frequency counter.
CCW: Motor drives slowly.
CW: Motor drives fast.

2.14. Slide Base Position Adjustment (on the Logic P.C.B. Ass'y)

- (1) Pull out the connector CN604 on the Logic P.C.B. Ass'y.
- (2) Ground TP604 to set the cassette case to its side A.
- (3) Adjust VR607 to obtain a gap of 2 to 4 mm as shown in Fig. 2.23.
- (4) Ground TP603 and TP604 to set the cassette case to its side B.
- (5) Adjust VR606 to obtain a gap of 2 to 4 mm as shown in Fig. 2.23.
- (6) Ground only TP603 to set the cassette case to its eject position.
- (7) Adjust VR605 to the position where the cassette case is about to start rotation.
- (8) Repeat above steps (2) to (7) two or three times.
- (9) Plug CN604 into the original place.

2.15. Lubrication

This is a lubrication-free cassette deck except when parts are replaced. Apply the following lubricant for each replaced part:

- (1) LAUNA #100
Capstan Shaft
Pressure Roller Shaft
Thrust Cap
- (2) FLOIL GB-TS-1
Reel Hub Shaft
Thrust portion on the Capstan Shaft
FLOIL GB-TS-1, made by Kanto Chemicals Co., Ltd. in Japan.
We suggest that you use the above or equivalent type. If unavailable please contact Kanto Chemicals Co., Ltd., 2-7 Kanda Sakuma-cho, Chiyoda-ku, Tokyo 101 Japan.
- (3) Silicon Oil #3000 CST
Air Damper Piston

Note: Excessive lubrication may cause defective damper action as the 0.2 ϕ hole at the end of the cylinder may be filled with oil.

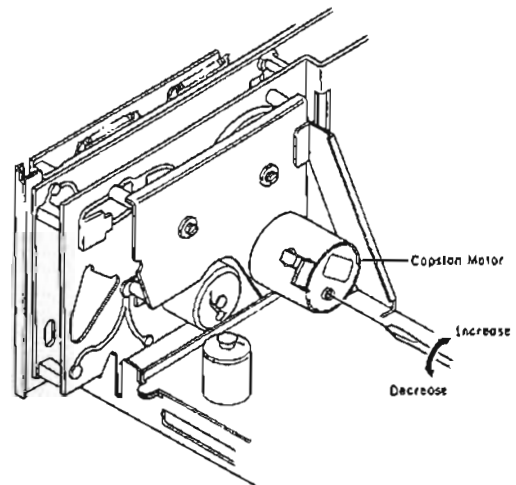

Fig. 2.22

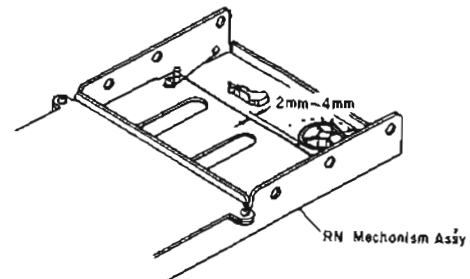

Fig. 2.23

3. PARTS LOCATION FOR ELECTRICAL ADJUSTMENT

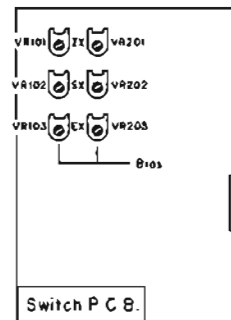
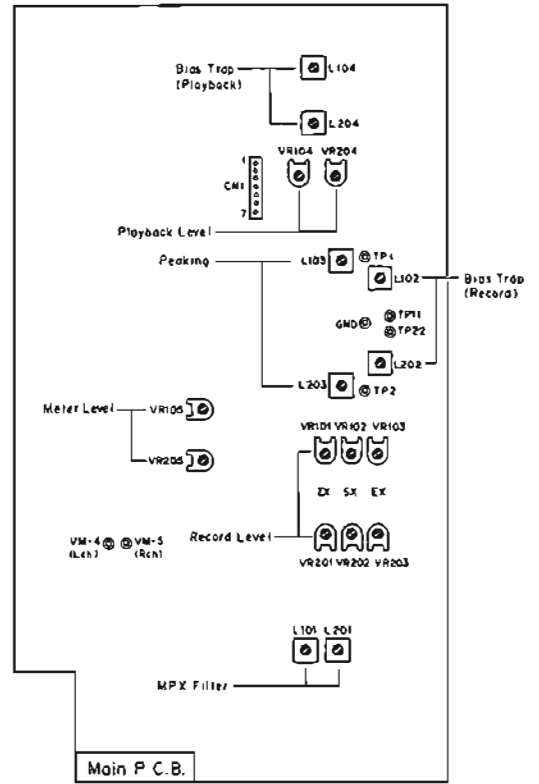
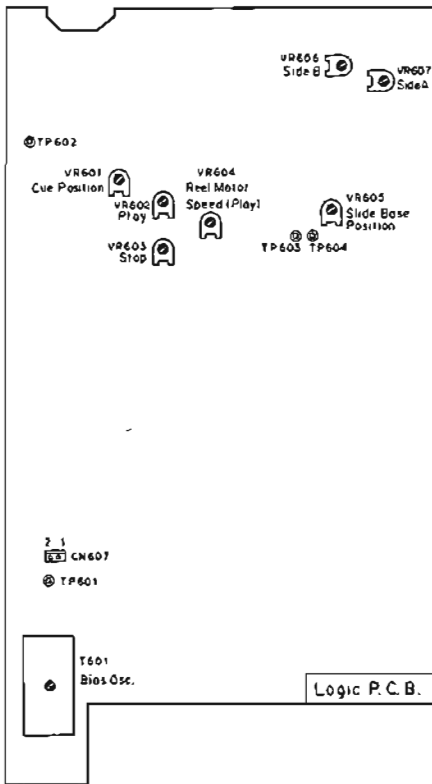

Fig. 3

4. ELECTRICAL ADJUSTMENTS AND MEASUREMENTS

Notes: 1. Electrical adjustment should be performed after mechanical adjustment is completed.

2. Before adjustment, set the Bias Tune control on the Front Panel to its mechanical center position.

4.1. Adjustment and Measurement Instructions

STEP	ITEM	SIGNAL SOURCE	OUTPUT CONNECTION	MODE	ADJUSTMENT	REMARKS
1	Tape Speed Adjustment	3 kHz Speed and Wow/Flutter Tape (DA09006C)	Frequency Counter to Output Jacks	Playback Eq. SW — 70 μ s	Tape Speed Adjustment Volume	Adjust the volume incorporated in the capstan motor to obtain 3 kHz \pm 0.5% on the frequency counter.
2	Meter Level Calibration	400 Hz to Input Jacks	VTVM to VM-4, VM-5 on Main P.C.B.	Monitor SW — Source	Main P.C.B. VR105, VR205	<ol style="list-style-type: none"> 1. Feed in 400 Hz, then adjust the Input Level controls to obtain 1.0 V —1 dB on the VTVM. 2. Adjust VR105 (VR205) so that the 0 dB segment of the level meter starts illuminating. 3. Adjust the Input Level control to obtain 1.0 V on the VTVM, then decrease the generator output level by 20 dB. 4. Check to insure that the segment for —20 dB illuminates.
3	MPX Filter Adjustment	19 kHz \pm 100 Hz to Input Jacks	VTVM to Output Jacks	Monitor SW — Source Dolby NR SW — OFF MPX SW — ON	Main P.C.B. L101, L201	<ol style="list-style-type: none"> 1. Turn the Output Level control fully clockwise (maximum position). 2. Adjust the Input Level controls to obtain 1 V on the VTVM. 3. Set the MPX Filter switch to ON, then adjust L101 (L201) to obtain the minimum reading on the VTVM (the minimum reading will be less than —30 dB).
4	Playback Head Track Alignment	1 kHz Track Alignment Tape (DA09007B)	VTVM to Output Jacks	Playback Monitor SW — Tape Eq. SW — 70 μ s Dolby NR SW — OFF MPX SW — OFF	PH Height Gear	Adjust the PH Height Gear to obtain minimum readings of both channels on the VTVM. Refer to "Playback Head Height Adjustment and Azimuth Alignment" in item 2.9.
5	Playback Head Azimuth Alignment	15 kHz Azimuth Tape (DA09004B)	VTVM to Output Jacks	Playback Monitor SW — Tape Eq. SW — 70 μ s Dolby NR SW — OFF MPX SW — OFF	Playback Head Azimuth Alignment Screw	Adjust the Playback Head Azimuth Alignment Screw to obtain maximum readings of both channels on the VTVM. Refer to "Playback Head Height Adjustment and Azimuth Alignment" in item 2.9. Note: Repeat steps 4 and 5 one or two times to obtain optimum performance.
6	Playback Level Calibration	400 Hz Level Tape (DA09005B)	VTVM to VM-4, VM-5 on Main P.C.B.	Same as above	Main P.C.B. VR104, VR204	Adjust VR104 (VR204) to obtain 1.0 V on the VTVM.
7	Playback Frequency Response Adjustment	400 Hz Level Tape (DA09005B) 10 kHz PB Frequency Response Tape (DA09003B) 15 kHz PB Frequency Response Tape (DA09002B) 20 kHz PB Frequency Response Tape (DA09001B)	VTVM to Output Jacks	Playback Monitor SW — Tape Tape SW — SX Eq. SW — 70 μ s Dolby NR SW — OFF MPX SW — OFF	Main P.C.B. R143, R243 R144, R244	<ol style="list-style-type: none"> 1. Load a 400 Hz level tape and play it back. Adjust the Output Level control to a certain level (0 dB for example). 2. Load 10 kHz, 15 kHz and 20 kHz PB frequency response tapes and adjust the playback head azimuth to obtain maximum levels on the VTVM with each tape. Short R143 (R243) or R144 (R244) to obtain the following levels against the level for the 400 Hz level tape. 10 kHz: —20 dB —2 dB to +2 dB 15 kHz: —20 dB —2 dB to +3 dB 20 kHz: —20 dB —2 dB to +4 dB 3. Conduct step 5 "Playback Head Azimuth Alignment". 4. If above is not sufficient, refer to "Playback Frequency Response Adjustment" in item 4.2.
8	Bias Oscillation Frequency and Erase Current Adjustment		VTVM across the additional 0.1 Ω resistor and Frequency Counter to CN807-1 on Logic P.C.B.	Record, Pause Monitor SW — Source Tape SW — ZX Eq. SW — 70 μ s Dolby NR SW — OFF MPX SW — OFF	Logic P.C.B. T801 R961, R960	<ol style="list-style-type: none"> 1. Connect an additional 0.1 Ω resistor in series to the Erase Head, then connect a VTVM across it. 2. Adjust T601 to obtain 105 kHz on the frequency counter. 3. Check the erase current by the VTVM. Erase current will be in a range of 310 mA to 400 mA (typically approx. 350 mA). If erase current is not sufficient, increase it by shorting R961 or R960. 4. After completion of the erase current adjustment, re-check the bias oscillation frequency. 5. Remove the additional 0.1 Ω resistor.
9	Record Amplifier Equalizer Adjustment	23 kHz (—20 dB) to Input Jacks	VTVM to TP11, TP22 on Main P.C.B.	Same as above	Main P.C.B. L103, L203	<ol style="list-style-type: none"> 1. Remove the bias-cut-jumper from the dip side of the Logic P.C.B. Ass'y. 2. Adjust L103 (L203) to obtain approx. +16 dB at 23 kHz on the VTVM. 3. Re-solder the bias-cut-jumper.
10	Bias Trap Adjustment (Record Amp.)	Remove input signals	VTVM to TP1, TP2 on Main P.C.B.	Same as above	Main P.C.B. L102, L202	Adjust L102 (L202) to obtain minimum reading on the VTVM.

STEP	ITEM	SIGNAL SOURCE	OUTPUT CONNECTION	MODE	ADJUSTMENT	REMARKS
11	Bias Trap Adjustment (Playback Amp.)	Remove input signals	VTVM to CN1-1, CN1-2 on Main P.C.B.	Record, Pause Monitor SW — Tape Tape SW — ZX Eq. SW — 70 μ s Dolby NR SW — OFF MPX SW — OFF	Main P.C.B. L104, L204	Adjust L104 (L204) to obtain minimum reading on the VTVM.
12	Record Head Height Adjustment	400 Hz (0 dB) to Input Jacks	VTVM to Output Jacks	Record, Playback Monitor SW — Tape Tape SW — SX Eq. SW — 70 μ s Dolby NR SW — OFF MPX SW — OFF	RH Height Gear	Adjust the RH Height Gear to obtain maximum readings of both channels on the VTVM. Refer to "Record Head Height Adjustment and Azimuth Alignment" in item 2.9.
13	Record Head Azimuth Alignment	15 kHz (-20 dB) to Input Jacks	VTVM to Output Jacks	Same as above	Record Head Azimuth Alignment Screw	Adjust the Record Head Azimuth Alignment Screw to obtain maximum readings of both channels on the VTVM. Refer to "Record Head Height Adjustment and Azimuth Alignment" in item 2.9. Note: Repeat steps 12 and 13 one or two times to obtain optimum performance.
14	Record Level Calibration and Recording Bias Current Adjustment	400 Hz and 15 kHz and 10 kHz/20 kHz (-20 dB) to Input Jacks	VTVM and Distortion Meter to Output Jacks	Record, Playback Tone — 400 Hz/15 kHz Monitor SW — Source/Tape Tape SW — ZX/SX/EX Eq. SW — 70 μ s (ZX/SX) 120 μ s (EX) Dolby NR SW — C-Type/B-Type/OFF MPX SW — OUT	Main P.C.B. (Level) ZX: VR101, VR201 SX: VR102, VR202 EX: VR103, VR203 Switch P.C.B. (Bias) ZX: VR101, VR201 SX: VR102, VR202 EX: VR103, VR203	Adjustment should be made in the order of ZX, SX and EX. 1. Set the Monitor switch to Source and Dolby NR switch to C-Type. 2. Feed in 400 Hz, then set the Input Level controls to obtain 0 dB (1 V) on the VTVM. 3. Set the Monitor switch to Tape. 4. Load a reference ZX tape (DA09037B), reference SX tape (DA09025B) and reference EX tape (DA09066B). 5. Adjust Record Cal. VR101 (VR201) for ZX, VR102 (VR202) for SX and VR103 (VR203) for EX on the Main P.C.B. Assy to center position. 6. Feed in 400 Hz (0 dB), then record and play it back. Adjust Bias VR101 (VR201) for ZX, VR102 (VR202) for SX and VR103 (VR203) for EX on the Switch P.C.B. Assy to obtain the maximum readings on the VTVM. 7. Feed in 15 kHz (-20 dB), then adjust Bias VR101 (VR201), VR102 (VR202) and VR103 (VR203) on the Switch P.C.B. Assy to obtain the same readings as source monitor levels on the VTVM. 8. Feed in 400 Hz (0 dB), then adjust Record Cal. VR101 (VR201), VR102 (VR202) and VR103 (VR203) on the Main P.C.B. Assy to obtain 0 dB on the VTVM. 9. Repeat above 7 and 8 two or three times to obtain optimum performance. 10. Set the Dolby NR switch to OFF. 11. Feed in 10 kHz (-20 dB) and 20 kHz (-20 dB), then record and play them back. Check to insure that the levels are within -20 dB \pm 3 dB against the levels in Dolby NR C-Type. 12. Set the Dolby NR switch to B-Type. 13. Feed in 10 kHz (-20 dB) and 20 kHz (-20 dB), then record and play them back. Check to insure that the levels are within -20 dB \pm 3 dB against the levels in Dolby NR OFF. 14. Check to insure whether the total harmonic distortion is less than 0.9% for ZX tape and 1.0% for SX and EX tapes. 15. If above is not sufficient, repeat 6 to 14 till satisfactory results are obtained.
15	Overall Frequency Response Adjustment	400 Hz (0 dB) and 20 Hz to 20 kHz (-20 dB) to Input Jacks	VTVM to Output Jacks	Record, Playback Monitor SW — Source/Tape Tape SW — ZX/SX/EX Eq. SW — 70 μ s (ZX/SX) 120 μ s (EX) Dolby NR SW — OFF MPX SW — OUT	Main P.C.B. L103, L203	1. Set the Monitor switch to Source. 2. Feed in 400 Hz (0 dB) and adjust the Input Level controls to obtain 0 dB on the VTVM. 3. Switch the Generator output level to -20 dB. 4. Set the Monitor switch to Tape, then record and play it back. 5. Feed in 20 Hz to 20 kHz (-20 dB), and check to insure whether the output levels are within -20 dB \pm 3 dB. 6. If above is not sufficient, adjust L103 (L203) to obtain approx. -20 dB on the VTVM at 20 kHz. 7. Conduct step 14 "Record Level Calibration and Recording Bias Current Adjustment". 8. If above is not sufficient, precise re-adjustment of step 7 "Playback Frequency Response", replacement of Playback Head or Record Head, check on item 2.11 "Tape Travelling Adjustment" will be required.

STEP	ITEM	SIGNAL SOURCE	OUTPUT CONNECTION	MODE	ADJUSTMENT	REMARKS
16	Crosstalk Measurement	1 kHz to Input Jacks	1 kHz Band Pass Filter and VTVM to Output Jacks	Record and Playback Monitor SW — Tape Tape SW — ZX Eq. SW — 70 μ s Dolby NR SW — OFF		1. Erase a reference ZX tape with a bulk eraser. 2. Adjust the Input Level controls to obtain 0 dB on the VTVM, and record the signals on the reference tape. 3. Turn the cassette tape the other way round and play it back. 4. Measure the difference between 2 and 3.
17	Channel Separation Measurement	1 kHz to Input Jacks	Same as above	Same as above		1. Erase a reference ZX tape with a bulk eraser. 2. Adjust the L ch (R ch) Input Level control to obtain 0 dB on the VTVM, and close the R ch (L ch) Input Level control. 3. Record and play it back, then measure the R ch (L ch) level.
18	Erasure Measurement	1 kHz to Input Jacks	Same as above	Same as above		1. Erase a reference ZX tape with bulk eraser. 2. Adjust the Input Level controls to obtain 0 dB on the VTVM, and record the signals on the reference tape. 3. Rewind the tape then close the Input Level controls. 4. Record and play it back, then measure the difference between 2 and 3.
19	Signal to Noise Ratio Measurement	400 Hz to Input Jacks	VTVM and Distortion Meter to Output Jacks	Record and Playback Monitor SW — Tape Tape SW — ZX Eq. SW — 70 μ s Dolby NR SW — B-Type/C-Type		1. Set the Dolby NR switch to B-Type/C-Type. 2. Feed in 400 Hz and record and play it back. 3. Adjust the Input Level controls to obtain 3% total harmonic distortion in Playback mode. 4. Close the Input Level controls, then record. 5. After rewind, play back and check the output level difference between 2 and 3. Note: The filter of IHF-A curve shall be used in the measurements.
20	Total Harmonic Distortion Measurement	400 Hz to Input Jacks	Distortion Meter to Output Jacks	Record and Playback Monitor SW — Tape Tape SW — ZX/SX/EX Eq. SW — 70 μ s (ZX/SX) 120 μ s (EX) Dolby NR SW — OFF		1. Adjust the Input Level controls to obtain 0 dB on the VTVM. 2. Record and play it back. 3. Read the distortion meter and check to insure that the distortion is less than 0.9% for ZX tape and 1.0% for SX and EXII tapes.
21	Wow/Flutter Measurement	3 kHz Speed and Wow/Flutter Tape (DA09006C)	Wow/Flutter Meter to Output Jacks	Playback Monitor SW — Tape Eq. SW — 70 μ s		Play back and read the wow/flutter meter.

4.2. Playback Frequency Response Adjustment

Figs 4.1 and 4.2 show the playback amp. circuit for adjustment and the playback equalization curve.

This adjustment will be required if playback level is not sufficient during playing back a 20 kHz PB frequency response tape.

The peaking portion of the equalization curve compensates the gap loss of the playback head. Peaking level is varied by the short circuit of R143 (R243) or R144 (R244) on the Main P.C.B.

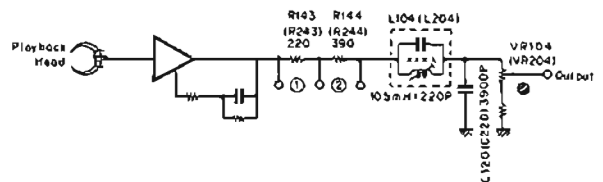

Fig. 4.1

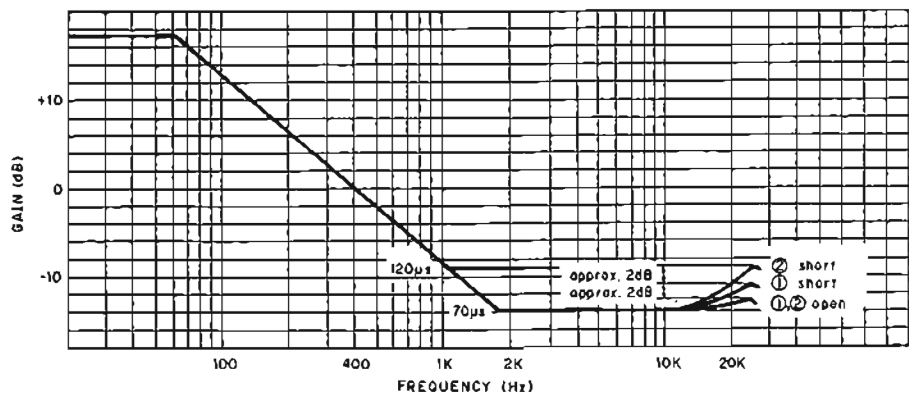

Fig. 4.2

4.3. Dolby NR Circuit Check

Dolby NR circuit incorporates Dolby NR ICs which have no adjustment point.

Perform the following checks and make sure that the IC operates accurately, i.e., accuracy of frequency response through IC.

4.3.1. Dolby NR B-Type Circuit Check

(1) Playback Dolby NR Circuit

Signal Source: 1.4 kHz to CN1-1 (CN1-2) on Dolby NR P.C.B.
 Output Connection: VTVM to Output Jacks
 Mode: Stop
 Monitor SW — Tape
 Dolby NR SW — B-Type/OFF

- (a) Connect a VTVM to the Output Jacks.
- (b) Set the Dolby NR switch to B-Type. Feed in 1.4 kHz to CN1-1 (CN1-2) and adjust the generator output control to obtain 100 mV on the VTVM.
- (c) Set the Dolby NR switch to OFF. Check to insure that the reading is +3.2 dB \pm 1.5 dB on the VTVM.

(2) Record Dolby NR Circuit

Signal Source: 1.4 kHz to Input Jacks
 Output Connection: VTVM to Output Jacks
 Mode: Stop
 Monitor SW — Source
 Dolby NR SW — B-Type/OFF

- (a) Connect a VTVM to the Output Jack.
- (b) Feed in 1.4 kHz and adjust the Input Level controls to obtain 100 mV/31.6 mV on the VTVM.
- (c) Remove the VTVM from the Output Jacks and reconnect it to CN2-1 (CN2-2) on the Dolby NR P.C.B. Ass'y.
- (d) Check to insure that the reading at CN2-1 (CN2-2) corresponds to the following with Dolby NR switch OFF and B-Type.

Input Level at MS25, MS26	Level at CN2-1, CN2-2	
	Dolby NR OFF	Dolby NR B-Type
100 mV	0 dB	+3.2 dB \pm 1.5 dB
31.6 mV	0 dB	+8.2 dB \pm 1.5 dB

4.3.2. Dolby NR C-Type Circuit Check

(1) Playback Dolby NR Circuit

Signal Source: 1.4 kHz to CN1-1 (CN1-2) on Dolby NR P.C.B.
 Output Connection: VTVM to Output Jacks
 Mode: Stop
 Monitor SW — Tape
 Dolby NR SW — C-Type/OFF

- (a) Connect a VTVM to the Output Jacks.
- (b) Set the Dolby NR switch to C-Type. Feed in 1.4 kHz to CN1-1 (CN1-2) and adjust the generator output control to obtain 100 mV on the VTVM.
- (c) Set the Dolby NR switch to OFF. Check to insure that the reading is +6.5 dB \pm 1.5 dB on the VTVM.

(2) Record Dolby NR Circuit

Signal Source: 1.4 kHz to Input Jacks
 Output Connection: VTVM to Output Jacks
 Mode: Stop
 Monitor SW — Source
 Dolby NR SW — C-Type/OFF

- (a) Connect a VTVM to the Output Jacks.
- (b) Feed in 1.4 kHz and adjust the Input Level controls to obtain 100 mV/31.6 mV on the VTVM.
- (c) Remove the VTVM from the Output Jacks and reconnect it to CN2-1 (CN2-2) on the Dolby NR P.C.B. Ass'y.
- (d) Check to insure that the reading at CN2-1 (CN2-2) corresponds to the following with Dolby NR switch OFF and C-Type.

Input Level at MS25, MS26	Level at CN2-1, CN2-2	
	Dolby NR OFF	Dolby NR C-Type
100 mV	0 dB	+6.5 dB \pm 1.5 dB
31.6 mV	0 dB	+11.4 dB \pm 1.5 dB

5. MECHANISM ASS'Y AND PARTS LIST

5.1. Synthesis

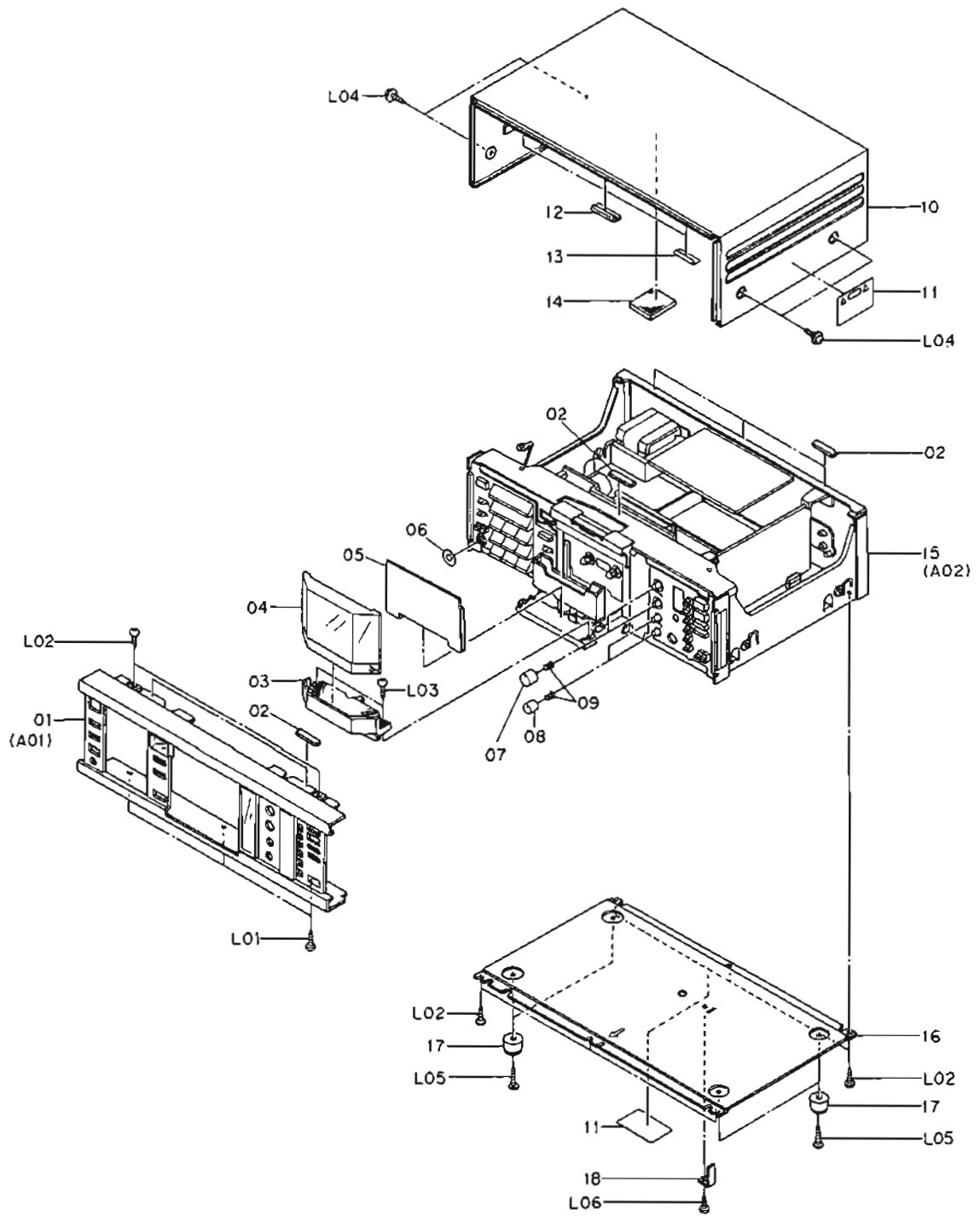

Fig. 5.1

5.2. Front Panel Ass'y (A01)

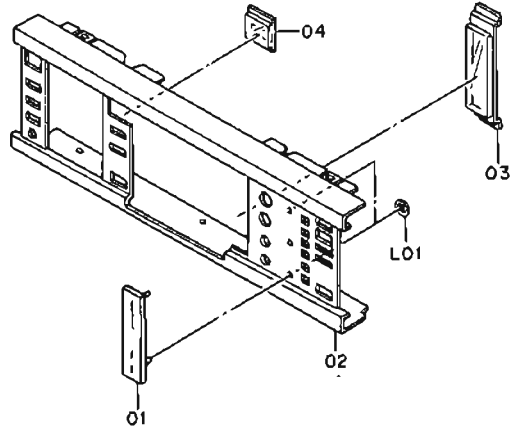

Fig. 5.2

Schematic Ref. No.	Part No.	Description	Q'ty	Schematic Ref. No.	Part No.	Description	Q'ty
		Synthesis		A01	HA04562A	Front Panel Ass'y RX505	1
					HA04568A	Front Panel Ass'y RX505E	1
						Serial No.: A80401001 -	
01	HA04562A	Front Panel Ass'y RX505	1				
	HA04568A	Front Panel Ass'y RX505E	1				
02	0J04560A	Top Cover Cushion	6	01	0H04335A	Dressing Plate	1
03	HA04564A	CAT Bottom Ass'y	1	02	0H04332A	Front Panel RX505	1
04	0H04345A	CAT Window	1		0H04355A	Front Panel RX505E	1
05	DA03735A	Caution Card Ass'y	1	03	0H04334A	Meter Cover	1
06	0J04816A	Headphone Himeion	1	04	0H04333A	Counter Lens	1
07	0H04343A	Input Volume Knob	2	—	0J04627A	Adhesive Tape for Meter IC	2
08	0H04342A	Output Volume Knob	2	—	0J04745B	Adhesive Tape for Meter Cover	4
09	0H03737A	Volume Knob Base	4	L01	0E00132A	CS-Ring 4mm	2
10	0H04349A	Top Cover	1				
11	0M04377A	Caution Label	2				
12	0J04715A	Top Cover Cushion	1				
13	0J04080A	Top Cover Himeion	2				
14	0J04753A	Vibration Isolating Rubber	1				
15	—	Chassis Ass'y	1				
16	0J04737A	Bottom Cover	1				
17	0J03564A	Leg T-H	4				
18	0C08583C	Slide Locker	1				
L01	0E00921A	BT 3x8 @ Binding (Black Chromate)	3				
L02	0E00888A	BT 3x8 @ Binding (Chromate)	8				
L03	0E00818A	M3x8 @ Binding (Black Chromate)	2				
L04	0E03032A	BT 4x8 @ Pan Washer Faced (Black Chromate)	4				
L06	0E00865A	BT 3x10 @ Binding (Chromate)	4				
L08	0E03144A	BT 3x6 @ Binding (Red Chromate)	1				

5.3. Chassis Ass'y (A02)

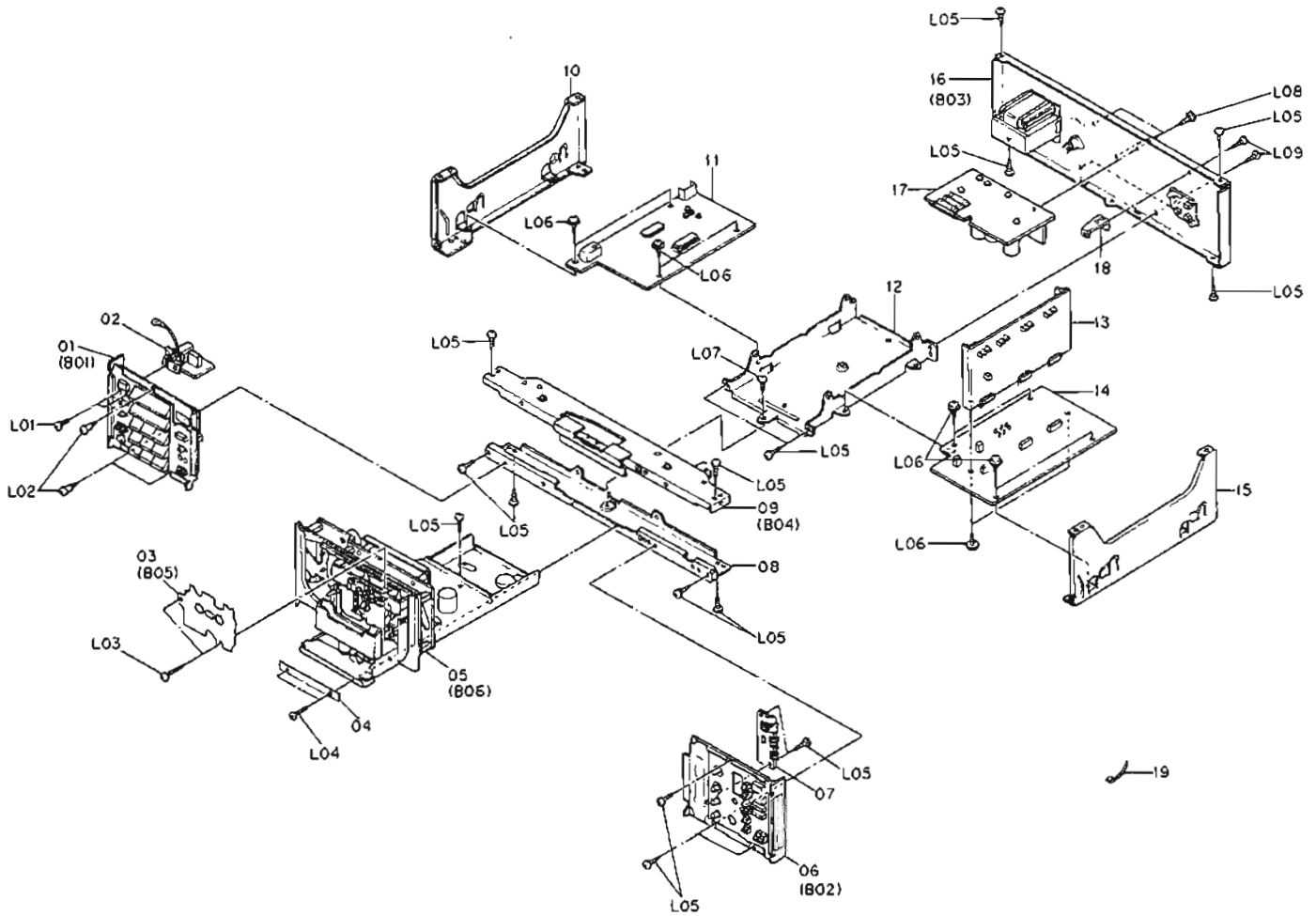

Fig. 5.3

Schematic Ref. No.	Part No.	Description	Qty	Schematic Ref. No.	Part No.	Description	Qty
A02	—	Chassis Ass'y RX505	1	17	BA05174A	DC Power Supply P.C.B. Ass'y	1
	—	Chassis Ass'y RX505E	1	18	OJ04807A	Dolby NR P.C.B. Holder	1
01	HA04559A	Front Panel Escutcheon L Ass'y	1	19	OB08515A	Insu-Lock	16
02	BA05188A	Power Switch P.C.B. Ass'y (RX505 (U.S.A. & Canada))	1		OJ04818A	CAT Mechanism Cushion	1
	BA05160A	Power Switch P.C.B. Ass'y (RX505 (Japan))	1		OB08374A	Fuse 1A (RX505 (U.S.A., Canada & Others))	1
	BA05189A	Power Switch P.C.B. Ass'y (RX505 (Others & Australia) & RX505E)	1		OB08962A	Fuse 2.5A (RX505 (U.S.A., Canada & Others))	2
03	CA08507A	Cover Plate Ass'y	1		OB08686A	Fuse 1A (RX505 (Japan))	1
04	OJ04757A	CAT Mechanism Himelon	1		OB08961A	Fuse 2.5A (RX505 (Japan))	2
05	CA08501A	Synthesis Mechanism Ass'y	1		OB08347U	Fuse 1AT (RX505 (Australia) & RX505E)	2
06	HA04560A	Front Panel Escutcheon R Ass'y	1		OB08457A	Fuse 500mAT (RX505 (Australia) & RX505E)	1
07	BA05142A	Indicator P.C.B. Ass'y	1		OM04190A	Fuse Label 1A 250V (RX505 (U.S.A., Canada, Others & Japan))	1
08	OJ04782D	Bottom Angle	1		OM04409A	Fuse Label 2.5A 250V (RX505 (U.S.A., Canada & Others))	2
09	HA04574A	Upper Angle Ass'y	1		OM04096C	Fuse Label 500mAT (RX505 (Australia) & RX505E)	1
10	OJ04750A	Side Chassis L	1		OM04191A	Fuse Label 1AT 260V (RX505 (Australia) & RX505E)	2
11	BA05173A	Logic P.C.B. Ass'y	1		OB08349B	Fuse Clip (RX505 (Australia) & RX505E)	6
12	OJ04749A	Center Chassis Ass'y	1		OM04343A	Fuse Caution (RX505 (U.S.A. & Canada))	1
13	BA05171A	Dolby NR P.C.B. Ass'y	1	L01	OE00818A	M3x8 @ Binding (Black Chromate)	2
14	BA05165A	Main P.C.B. Ass'y	1	L02	OE03135B	M3x8 @ Binding (Half threaded)	3
15	OJ04751A	Side Chassis R	1	L03	OE00950A	BT 3x14 @ Pan (Black Chromate)	2
16	HA04545A	Rear Panel Ass'y RX505 (U.S.A. & Canada)	1	L04	OE03115A	BT 3x8 @ Countersunk (Black Chromate)	2
	HA04546A	Rear Panel Ass'y RX505 (Japan)	1				
	HA04547A	Rear Panel Ass'y RX505 (Others)	1				
	HA04548A	Rear Panel Ass'y RX505 (Australia)	1				
	HA04549A	Rear Panel Ass'y RX505E (220V Class 2)	1				
	HA04544A	Rear Panel Ass'y RX505E (UK)	1				

5.4. Front Panel Escutcheon L Ass'y (B01)

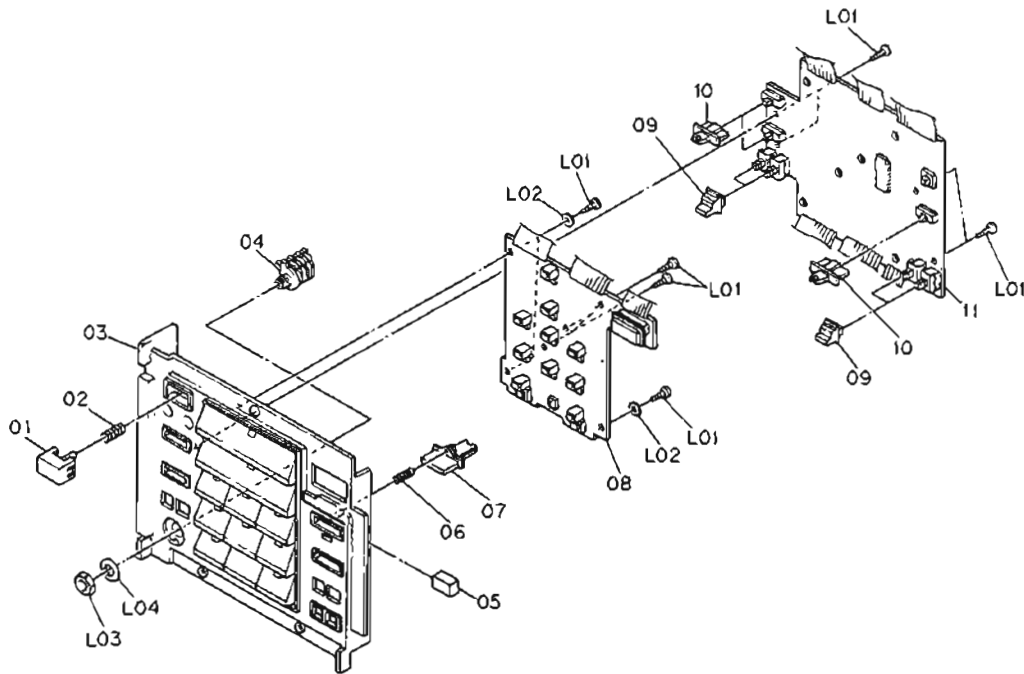

Fig. 5.4

Schematic Ref. No.	Part No.	Description	Qty	Schematic Ref. No.	Part No.	Description	Qty
				B01	HA04559A	Front Panel Escutcheon L Ass'y Serial No.: A80401001 -	1
L05	0E00868A	BT 3x8 @ Binding (Chromate)	18	01	0H04327A	Power Switch Button	1
L08	0E03157A	BT 3x8 @ Binding Washer Faced (Chromate)	10	02	0J04794A	Spring for Power Switch	1
L07	0E00867A	BT 3x6 @ Binding (Chromate)	1	03	HA04661B	Front Panel Escutcheon L Sub Ass'y	1
L08	0E00915A	BT 4x8 @ Binding (Black Chromate)	8	04	0B08511A	Headphone Jack	1
L09	0E00921A	BT 3x8 @ Binding (Black Chromate)	3	05	0C08611A	Cushion B	1
				06	0J04640A	Spring for Reset Switch	1
				07	0H04328A	Reset Button	1
				08	BA05175A	Control P.C.B. A Ass'y	1
				09	0H04337A	Push Switch Button	4
				10	0H04330A	Slide Switch Knob	3
				11	BA05187A	Control P.C.B. B Ass'y	1
				L01	0E00868A	BT 3x8 @ Binding (Chromate)	10
				L02	0E00157A	Plastic Washer 3mm	3
				L03	-	Headphone Jack Nut	(1)
				L04	-	Headphone Washer	(1)

5.5. Front Panel Escutcheon R Assy (B02)

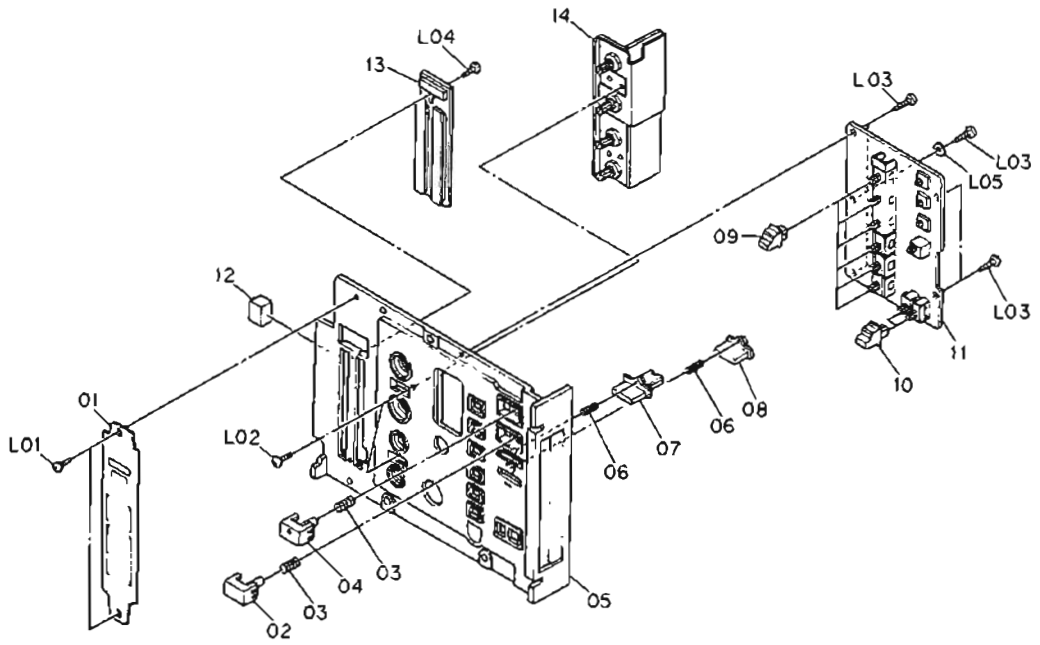

Fig. 5.5

5.6. Rear Panel Assy (B03)

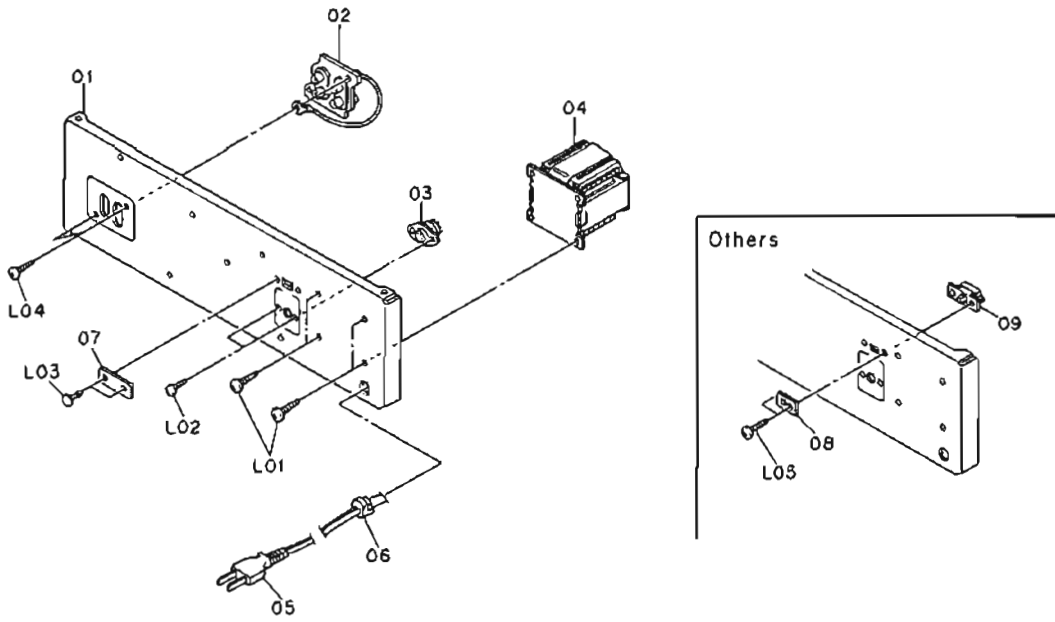

Fig. 5.6

Schematic Ref. No.	Part No.	Description	Qty
B02	HA04560A	Front Panel Escutcheon R Assy Serial No.: A80401001 -	1
01	OH04341A	Meter Scale	1
02	OH04340A	Reverse Button	1
03	OJ04784A	Spring for Eject Switch	2
04	OH04339A	Eject Button	1
05	OH04336A	Front Panel Escutcheon R	1
06	OJ04640A	Spring for A.R.S. Switch	2
07	OH04328A	A.R.S. Button	1
08	OH04338A	Monitor Switch Button	1
09	OH04370A	Selector Button	8
10	OH04337A	Push Switch Button	2
11	BA05168A	Switch P.C.B. Assy	1
12	OC08611A	Cushion B	1
13	BA05214A	Indicator P.C.B. Assy & Display Unit	1
14	BA05167A	Volume P.C.B. Assy	1
L01	OE00873A	BT 2.6x5 @ Binding (Chromate)	2
L02	OE00896A	M3x6 @ Binding (Chromate)	2
L03	OE00868A	BT 3x8 @ Binding (Chromate)	5
L04	OE00857A	BT 3x6 @ Binding (Chromate)	1
L05	OE00157A	Plastic Washer 3mm	1
B03	HA04545A	Rear Panel Assy RX505 (U.S.A. & Canada)	1
	HA04546A	Rear Panel Assy RX505 (Japan)	1
	HA04547A	Rear Panel Assy RX505 (Others)	1
	HA04548A	Rear Panel Assy RX505 (Australia)	1
	HA04544A	Rear Panel Assy RX505E (UK)	1
	HA04549A	Rear Panel Assy RX505E (220V Class 2) Serial No.: A80401001 -	1
01	OH04351C	Rear Panel RX505	1
	OH04357C	Rear Panel RX505E	1
02	OB81001A	4P Pin Jack	1
03	BA05198A	8P DIN Socket Assy (Consisting of followinga)	1
	(OB08584A)	8P DIN Socket	(1)
	(OB08752A)	8P-H Connector	(1)
04	OB50019A	Power Transformer 120V (RX505 (U.S.A. & Canada))	1
	OB50018A	Power Transformer 100V (RX505 (Japan))	1
	OB50021A	Power Transformer 115V/230V (RX505 (Others))	1
	OB50020A	Power Transformer 220V/240V (RX505 (Australia) & RX505E)	1
05	OB08533A	Power Cord (RX505 (U.S.A., Canada & Others))	1
	OB08219A	Power Cord (RX505 (Japan))	1
	OB05241A	Power Cord (RX505 (Australia))	1
	OB08093U	Power Cord (RX505E (220V Class 2))	1
	OB08348A	Power Cord (RX505E (UK))	1
06	OB08037U	Cord Bushing C (RX505 & RX505E (220V Class 2))	1
	OB08351A	Cord Bushing 4K-4 (RX505E (UK))	1
07	OJ04601B	Switch Cover (RX505 (U.S.A., Canada, Japan & Australia) & RX505E)	1
08	OM03948A	Voltage Lock Plate D (RX505 (Others))	1
09	OB07092U	Voltage Selector Switch (RX505 (Others))	1
-	OF01071A	Free-up Belt (RX505 (Australia) & RX505E)	1
L01	OE00915A	BT 4x8 @ Binding (Black Chromate)	4
L02	OE03072A	M2.6x6 @ Binding (Black Chromate)	2
L03	OB08583A	Plastic Rivet (RX505 (U.S.A., Canada, Japan & Australia & RX505E))	2
L04	OE00872A	BT 3x8 @ Binding (Black Chromate)	2
L05	OE00818A	M3x8 @ Binding (Black Chromate) (RX505 (Others))	2

5.7. Upper Angle Assy (B04)

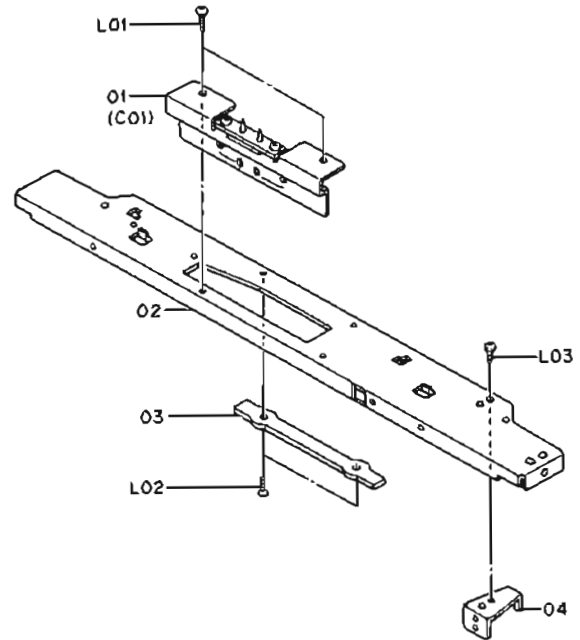

Fig. 5.7

5.8. Cover Plate Assy (B05)

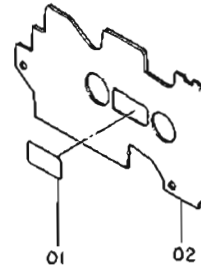

Fig. 5.8

Schematic Ref. No.	Part No.	Description	Qty
B04	HA04574A	Upper Angle Assy Serial No.: A80401001 -	1
01	HA04575A	Lid Cover Assy	1
02	OJ04788B	Upper Angle	1
03	OJ04808A	Holder Plate	1
04	OJ04807A	Dolby NR P.C.B. Holder	1
L01	OE00868A	BT 3x8 @ Binding (Chromate)	2
L02	OE03072A	BT 3x6 @ Countersunk (Black Chromate)	2
L03	OE00818A	M3x8 @ Binding (Black Chromate)	1
B05	CA08507A	Cover Plate Assy Serial No.: A80401001 -	1
01	OM04392A	Cassette Label (Gold)	1
02	OB08583A	Plastic Rivet	1

5.9. Synthesis Mechanism Ass'y (B06)

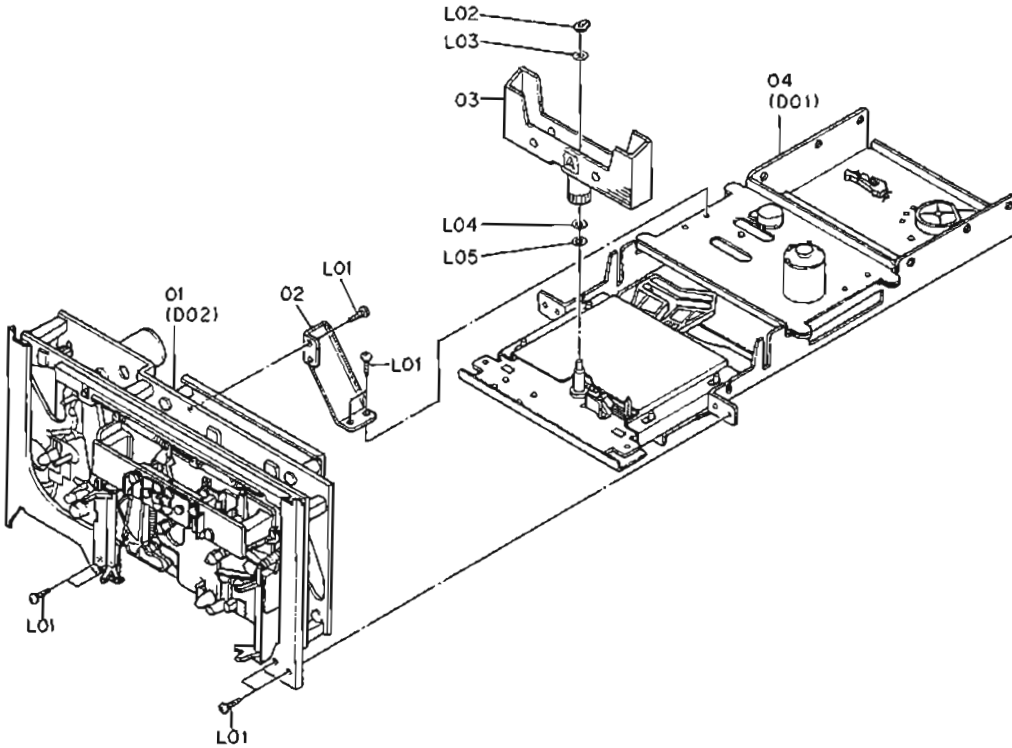

Fig. 5.9

5.10. Lid Cover Ass'y (C01)

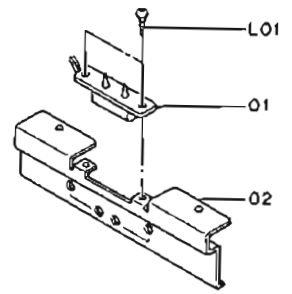

Fig. 5.10

Schematic Ref. No.	Part No.	Description	Qty	Schematic Ref. No.	Part No.	Description	Qty
B06	CA08501A	Synthesis Mechanism Ass'y Serial No.: A80401001 -	1	D02	CA08520A	Mechanism Ass'y RX505 Serial No.: A80401001 -	1
01	CA08520A	Mechanism Ass'y RX505	1	01	OC08568B	Mechanism Holder L	1
02	OC08597A	Rear Holder	1	02	OC08568B	Mechanism Holder R	1
03	CA08511A	Cassette Case Ass'y	1	03	CA08521A	Sub Mechanism Ass'y	1
04	CA08508A	RN Mechanism Ass'y	1	L01	OE08060A	BT 4x18 @ Binding (Toothed Lock Washer faced)	1
L01	OE00857A	BT 3x6 @ Binding (Chromate)	7	L02	OE03059A	BT 4x15 @ Binding (Toothed Lock Washer faced)	3
L02	OE00837A	Stopper Ring 3mm	1				
L03	OE00254A	Mylar Washer 3.1x7x0.2	1				
L04	OC08347A	Mylar Washer 3.1mm (0.25t)	1				
L05	OC08594A	Mylar Washer 3x0.5	1				
-	OE03163A	Mylar Washer 3x0.13	1	E01	CA08526A	Motor Holder Ass'y Serial No.: A80401001 -	1
C01	HA04676A	Lid Cover Ass'y Serial No.: A80401001 -	1	01	OC08527A	PM Gear	1
01	BA05143A	Lid Lamp P.C.B. Ass'y	1	02	OC08565B	Motor Holder	1
02	OH04377A	Lamp Cover	1	03	CA08527A	Drive Motor Ass'y	1
L01	OE03076A	M2.5x6 @ Binding (Chromate)	2	04	OB07240A	Volume 10K (B)	1
D01	CA08508A	RN Mechanism Ass'y Serial No.: A80401001 -	1	05	OB82201A	5P-H Connector	1
01	CA08528A	Motor Holder Ass'y	1	L01	OE00993A	Stopper Ring 6mm	1
02	OC08615A	Slide Cover B	1	L02	-	Volume Nut	(1)
03	OC08099B	Cam Motor Belt	1	L03	-	Volume Washer	(1)
04	OC08525A	SD Pulley	1	L04	OE00120A	M2.6x3 @ Pan (Chromate)	2
05	CA08509A	Slide Chassis Ass'y	1				
06	OC08133A	Skeleton Switch	1				
07	OB82203A	2P-H Connector	1				
08	CA08488A	Main Chassis Ass'y	1				
L01	OE00868A	BT 3x8 @ Binding (Chromate)	4				
L02	OE03022A	BT 2x4 @ Binding (Black Chromate)	2				
L03	OE00222A	E-Ring 2mm	1				
L04	OC08594A	Mylar Washer 3x0.5	1				
L05	OE00181A	E-Ring 3mm	4				
L06	OC08593A	Mylar Washer 4x0.5	8				
L07	OE00840A	BT 2x8 @ Pan (Chromate)	2				

5.11. RN Mechanism Assy (D01)

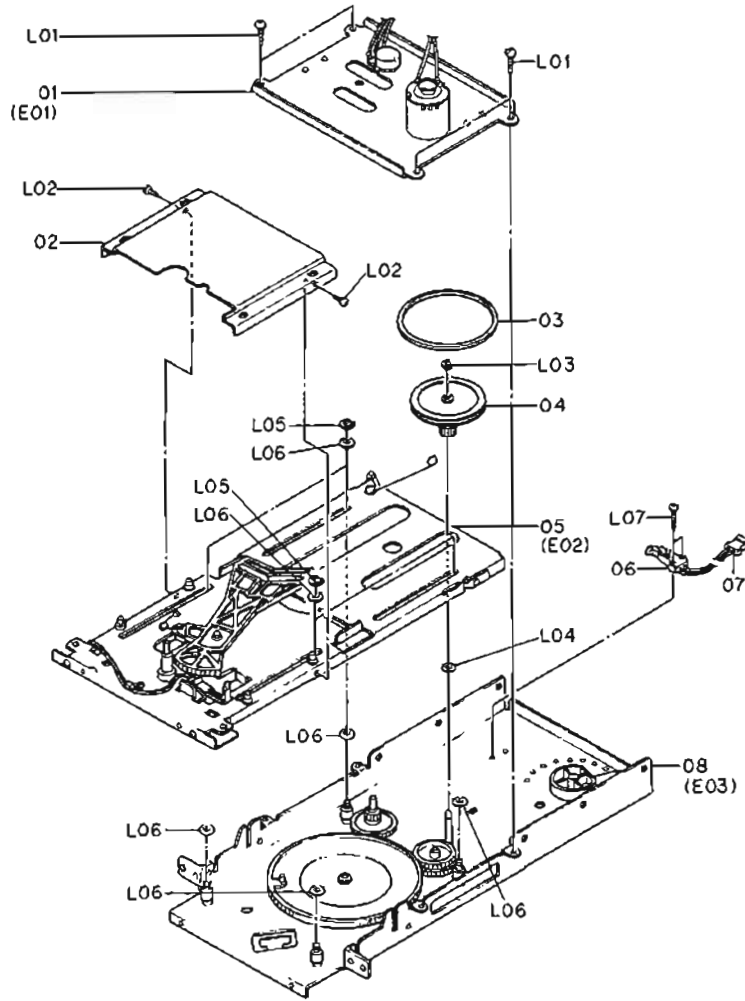

Fig. 5.11

5.12. Mechanism Assy RX505 (D02)

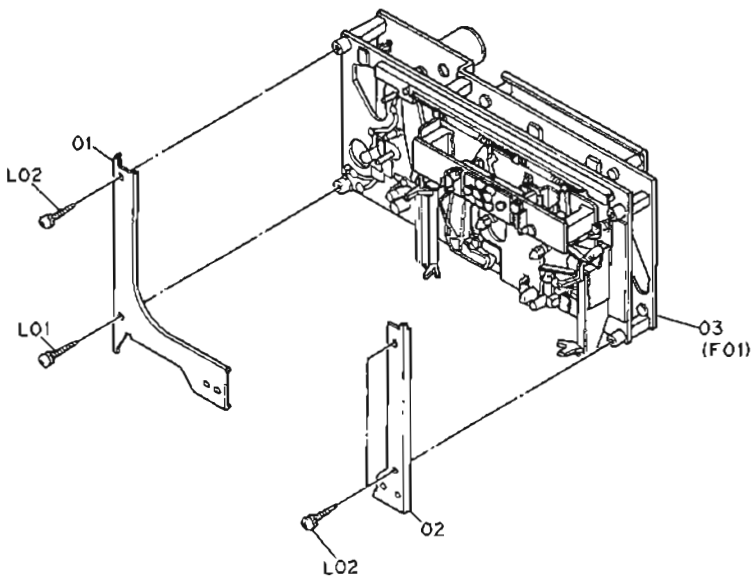

Fig. 5.12

5.13. Motor Holder Assy (E01)

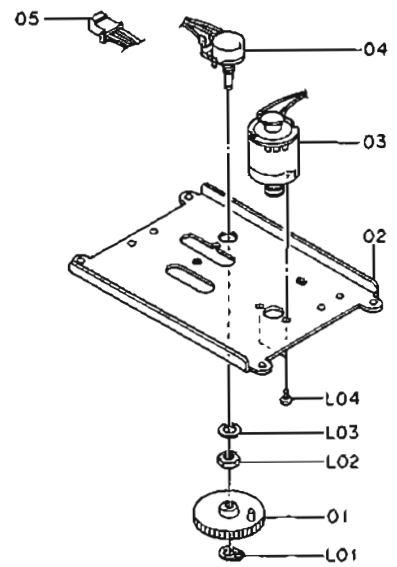

Fig. 5.13

5.14. Slide Chassis Ass'y (E02)

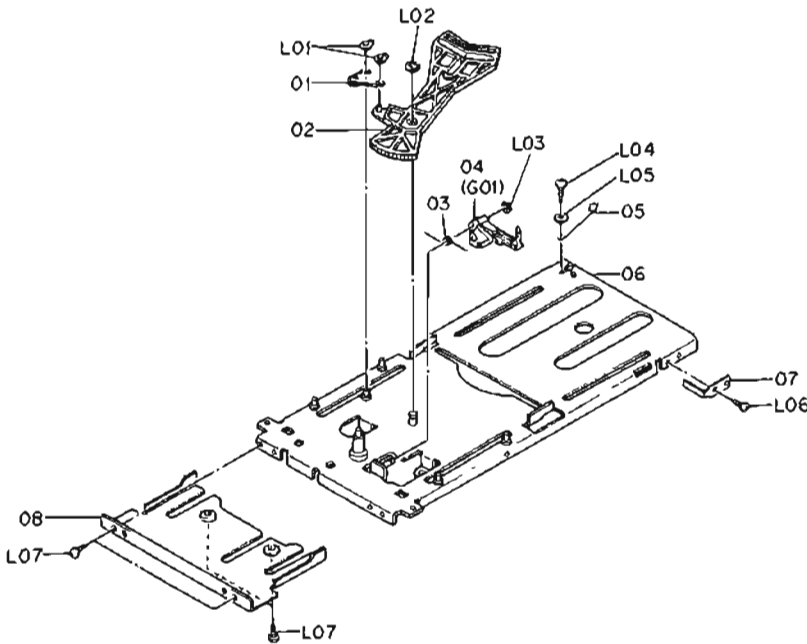

Fig. 5.14

5.15. Main Chassis Ass'y (E03)

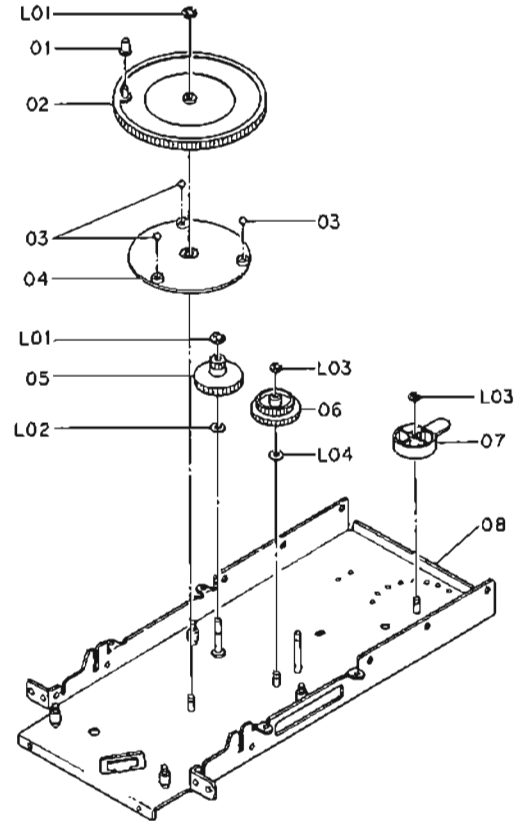

Fig. 5.15

Schematic Ref. No.	Part No.	Description	Qty	Schematic Ref. No.	Part No.	Description	Qty
E02	CA08509A	Slide Chassis Ass'y Serial No.: A80401001 -	1	F01	CA08521A	Sub Mechanism Ass'y Serial No.: A80401001 -	1
01	OC08548A	R Arm Spring	1	01	CA08017B	Flywheel Holder Ass'y	1
02	OC08529A	R Arm	1	02	OC08096C	Capstan Belt	1
03	OC08547A	Record Protector Switch Spring	1	03	CA08534A	Supply Flywheel Ass'y	1
04	CA08510A	Record Protector Switch Ass'y	1	04	OC08021B	Thrust Washer 3.1mm	1
05	OC08596A	WH Rod	1	05	CA08533A	Take-up Flywheel Ass'y	1
06	CA08475D	Slide Chassis Sub Ass'y	1	06	OC08020B	Thrust Washer 2.6mm	1
07	OC08598A	SS Plate	1	07	OC08243A	Flange Thrust Cap	2
08	OC08552A	Under Cover	1	08	OC08244A	Flange Thrust Spring	2
L01	OE00837A	Stopper Ring 3mm	2	09	CA08513A	Sub Mechanism Chassis Ass'y	1
L02	OE00181A	E-Ring 3mm	1	10	OC08099B	Control Motor Belt	1
L03	OE00042A	E-Ring 1.5mm	1	11	CA08522B	Main Mechanism Chassis Ass'y	1
L04	OE00857A	BT 3x6 @ Binding (Chromate)	1	12	CA08505A	Lock Arm L Ass'y	1
L05	OE00637A	Washer 3.3x7x0.5	1	13	CA08506A	Lock Arm R Ass'y	1
L06	OE03022A	BT 2x4 @ Binding (Black Chromate)	1	14	OB82199A	6P-H Connector	1
L07	OE03133A	BT 2.6x4 @ Binding (Black Chromate)	4	15	OB82204A	3P-H Connector	1
				16	OB8515A	Insu-Lock	10
				17	OC08620A	Head Height Adjustment Gear	2
E03	CA08488A	Main Chassis Ass'y Serial No.: A80401001 -	1	L01	OE00838A	BT 3x20 @ Pan (Chromate)	3
01	OC08584A	Collar	1	L02	OE00834A	BT 3x30 @ Pan (Chromate)	1
02	OC08623A	Main Gear	1	L03	OE00178A	Washer 3.3x8x0.5	2
03	OC08550A	Ball 4mm	3	L04	OE00835A	BT 3x25 @ Pan (Chromate)	1
04	OC08528A	Retainer	1	L05	OE00883A	BT 2x18 @ Pan (Chromate)	5
05	OC08526A	PMD Gear	1	L06	OE00846A	BT 3x8 @ Pan (Chromate)	3
06	OC08524A	SD Gear	1				
07	OC08543A	SS Cam	1				
08	CA08474C	Main Chassis Sub Ass'y	1				
L01	OE00181A	E-Ring 3mm	2				
L02	OC08593A	Mylar Washer 4x0.5	1				
L03	OE00222A	E-Ring 2mm	2				
L04	OC08594A	Mylar Washer 3x0.5	1				

5.16. Sub Mechanism Ass'y (F01)

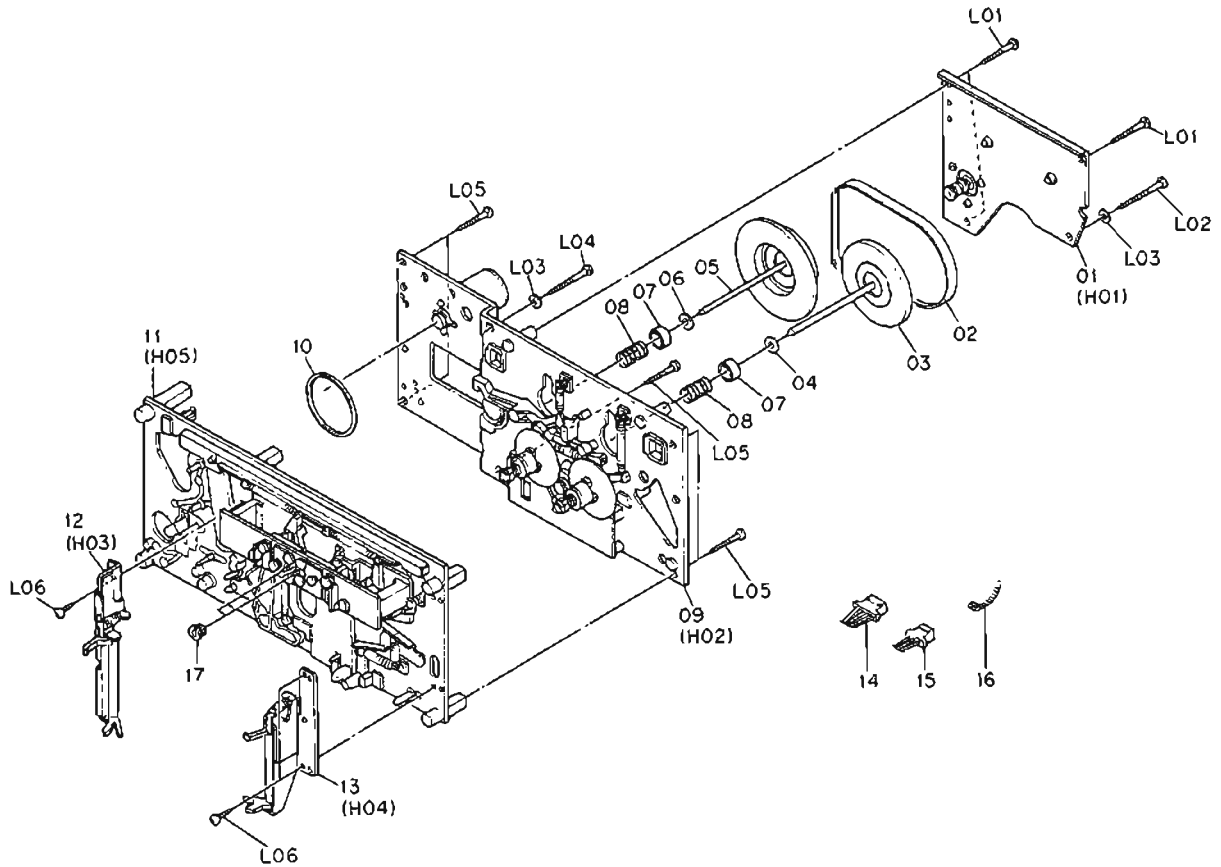

Fig. 5.16

5.17. Record Protector Switch Ass'y (G01)

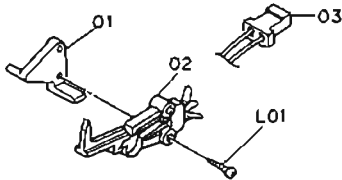

Fig. 5.17

5.18. Flywheel Holder Ass'y (H01)

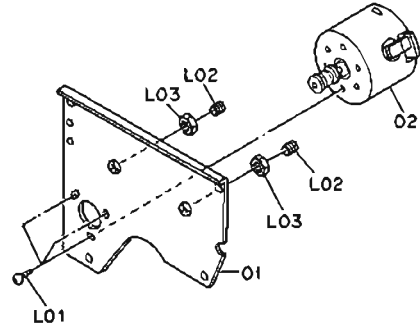

Fig. 5.18

Schematic Ref. No.	Part No.	Description	Qty	Schematic Ref. No.	Part No.	Description	Qty
G01	CA08510A	Record Protector Switch Ass'y Serial No.: A80401001 -	1	H01	CA08017B	Flywheel Holder Ass'y Serial No.: A80401001 -	1
01	0C08539A	Record Protector Switch Arm	1	01	0C08013I	Flywheel Holder	1
02	0C08540B	Skeleton Switch	1	02	CA08106B	Capstan Motor Ass'y	1
03	0E82075B	2P-H Connector	1	L01	0E00226A	M2.8x4 Pan (Chromate)	3
L01	0E00840A	BT 2x8 Pan (Chromate)	1	L02	0C08068C	Thrust Screw	2
				L03	0C03857A	Lock Nut	2

5.18. Sub Mechanism Chassis Ass'y (H02)

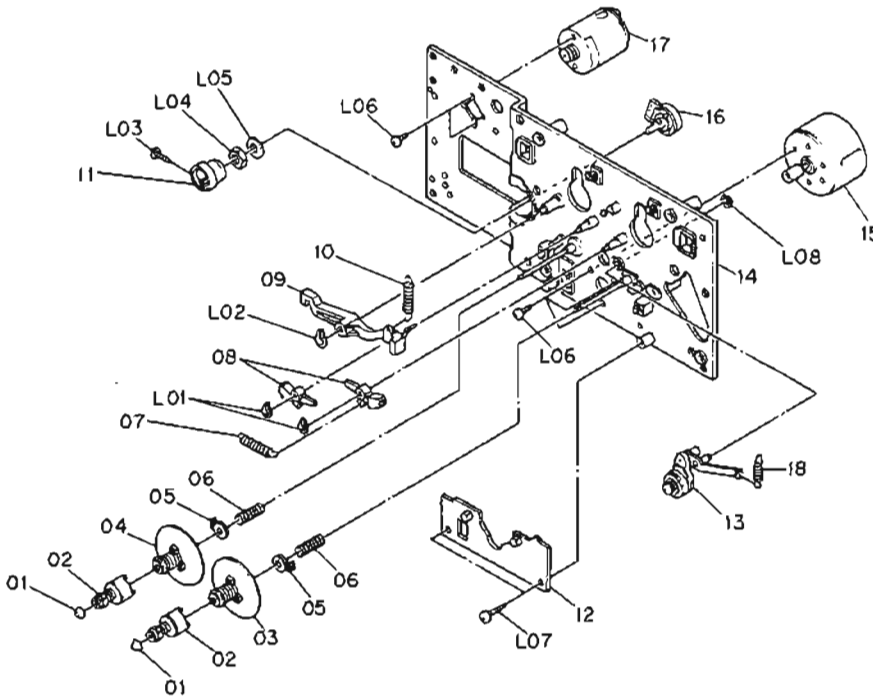

Fig. 5.19

5.20. Lock Arm L Ass'y (H03)

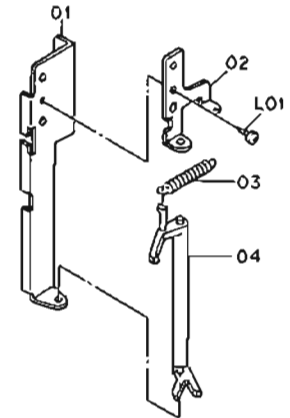

Fig. 5.20

5.21. Lock Arm R Ass'y (H04)

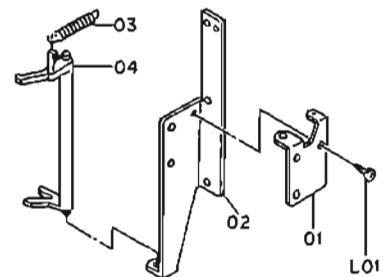

Fig. 5.21

Schematic Ref. No.	Part No.	Description	Qty	Schematic Ref. No.	Part No.	Description	Qty
H02	CA08513A	Sub Mechanism Chassis Ass'y Serial No.: A80401001 -	1	H04	CA08506A	Lock Arm R Ass'y Serial No.: A80401001 -	1
01	OC08039B	Reel Hub Head	2	01	OC08558A	Lock Arm Holder Right B	1
02	CA08038B	Reel Hub Pulley B Ass'y	2	02	OC08557A	Lock Arm Holder Right A	1
03	CA08515A	Reel Hub Supply Ass'y	1	03	OC08546A	Lock Arm Spring	1
04	CA08514A	Reel Hub Take-up Ass'y	1	04	OC08614A	Lock Arm Right	1
05	CA08039A	Back Tension Ass'y	2	-	OC08599A	Cushion	1
08	OC08610A	Back Tension Spring D	2	L01	OE00941A	BT 3x5 @ Binding (Black Chromate)	1
07	OC08129B	Brake Arm Spring	1				
08	CA08042A	Brake Arm Ass'y	2				
09	OC08030C	Brake Drive Arm	1	H05	CA08522B	Main Mechanism Chassis Ass'y Serial No.: A80401001 -	1
10	OC08128A	Brake Drive Arm Spring	1	01	CA08523A	Head Mount Base Ass'y	1
11	OC08053B	Volume Coupler	1	02	OC08313A	Pressure Roller Arm Bushing	2
12	BA05199A	TS Pulse P.C.B. Ass'y	1	03	CA08464A	Supply Pressure Roller Ass'y	1
13	CA08193A	Idler Arm Ass'y	1	04	OC08121A	Supply Pressure Roller Spring	1
14	CA08194A	Sub Chassis Ass'y B	1	05	OC08122C	Supply Pressure Roller Thrust Spring	1
15	CA08242A	Reel Motor Ass'y	1	06	CA08465A	Take-up Pressure Roller Ass'y	1
16	OB07240A	Volume 10K (B)	1	07	OC08250A	Supply Pressure Roller Spring B	1
17	CA08527A	Control Motor Ass'y	1	08	OC08183B	Take-up Pressure Roller Thrust Spring	1
18	OC08266A	Idler Arm Spring B	1	09	CA08530A	Head Base Ass'y	1
L01	OE00837A	Stopper Ring 3mm	2	10	OC08086B	Head Base Roller	3
L02	OE00838A	Stopper Ring 4mm	1	11	OC08182A	Pressure Roller Drive Bar B	1
L03	OE00859A	BT 2.6x8 @ Binding (Chromate)	1	12	CA08027A	Head Base Drive Arm Ass'y	1
L04	-	Volume Nut	(1)	13	GA02103A	EOK Erase Head	1
L05	-	Volume Washer	(1)	14	CA08028A	Pressure Roller Drive Arm Ass'y	1
L06	OE00226A	M2.6x4 @ Pan (Chromate)	5	15	OC08544B	Cassette Hold Arm	1
L07	OE00631A	BT 3x10 @ Pan (Chromate)	2	16	OC08120A	Cassette Hold Arm Spring	1
L08	OE00698A	E-Ring 2.5mm	1	17	CA08198A	Back Tension Arm Ass'y	1
				18	OC08254A	Back Tension Arm Collar	1
H03	CA08505A	Lock Arm L Ass'y Serial No.: A80401001 -	1	19	CA08347A	Main Chassis Ass'y	1
01	OC08555B	Lock Arm Holder Left A	1	20	CA08028A	Counter-Load Arm Ass'y	1
02	OC08556A	Lock Arm Holder Left B	1	21	OC08371A	Back Tension Arm Spring	1
03	OC08546A	Lock Arm Spring	1	22	OC08152A	Counter-Load Arm Spring Tube	1
04	OC08613A	Lock Arm Left	1	23	OC08029H	Control Cam	1
-	OC08599A	Cushion	1	24	OC08186A	Cam Drive Gear	1
L01	OE00941A	BT 3x5 @ Binding (Black Chromate)	1	25	CA08024A	Capstan Flange φ2.5 Ass'y	1

5.22. Main Mechanism Chassis Ass'y (H05)

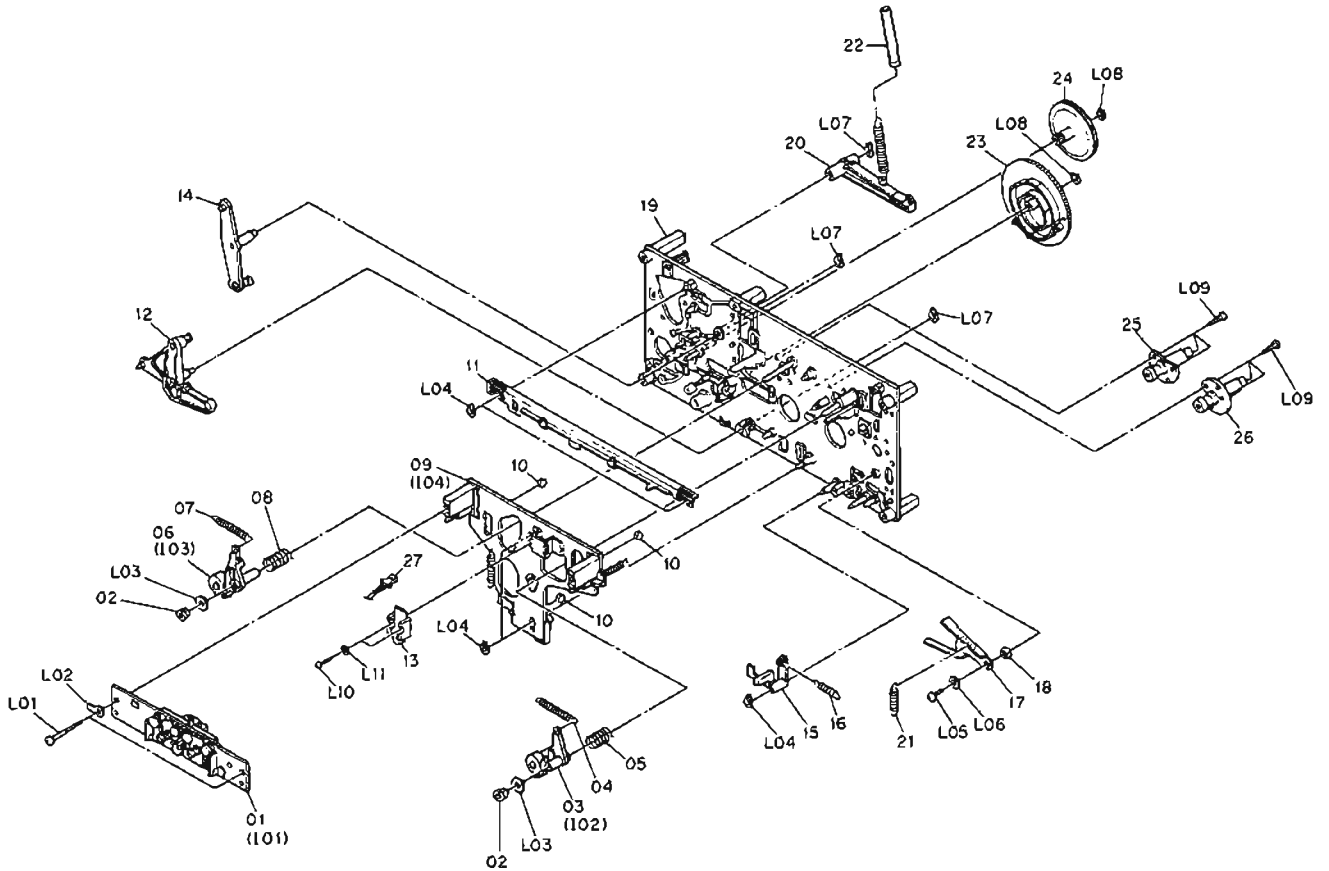

Fig. 5.22

Schematic Ref. No.	Part No.	Description	Qty
26	CA08023A	Capstan Flange ϕ 3.0 Ass'y	1
27	0B82166B	2P-H Connector	1
L01	0E00834A	BT 3×80 ϕ Pan (Chromate)	2
L02	0E00895A	Earth Lug 3mm	1
L03	0E00178A	Washer 3.3x8x0.5	2
L04	0E00837A	Stopper Ring 3mm	5
L05	0E00859A	BT 2.6x8 ϕ Binding (Chromate)	1
L06	0C08255A	Washer 2.6mm	1
L07	0E00838A	Stopper Ring 4mm	3
L08	0E00222A	E-Ring 2mm	2
L09	0E00876A	BT 2.6x8 ϕ Pan (Chromate)	6
L10	0E00951A	M1.7x7 ϕ Pan (Black Chromate)	2
L11	0E00952A	Washer 1.7mm	2
I01	CA08523A	Head Mount Base Ass'y Serial No.: A80401001 -	1
01	0C08621A	Head Height Adjustment Screw	4
02	0C08161B	Spring Stopper	2
03	0C08187B	Head Plate Spring	2
04	0C08619A	Azimuth Alignment Screw	2
05	CA08528A	Head Mount Base Sub Ass'y	1
06	CA08525A	P-8L Playback Head Ass'y	1
07	CA08524A	R-8L Record Head Ass'y	1

5.23. Head Mount Base Ass'y (I01)

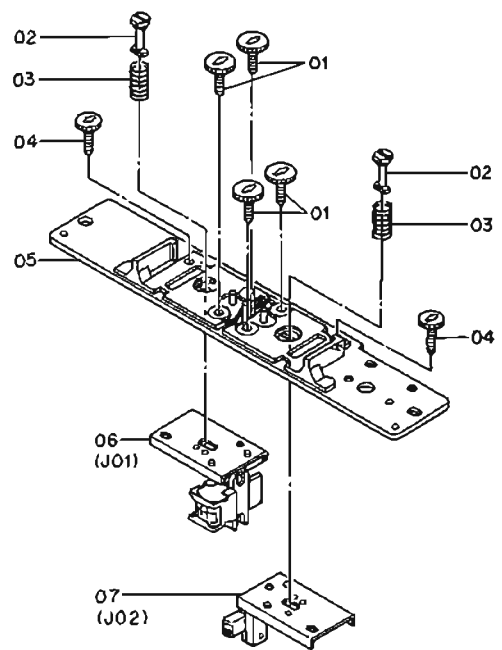

Fig. 5.23

5.24. Supply Pressure Roller Ass'y (I02)

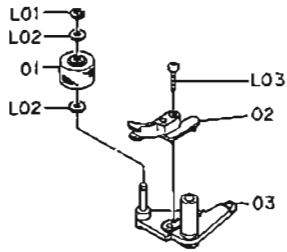

Fig. 5.24

5.25. Take-up Pressure Roller Ass'y (I03)

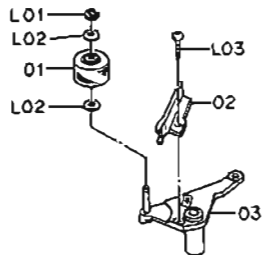

Fig. 5.25

5.26. Head Base Ass'y (I04)

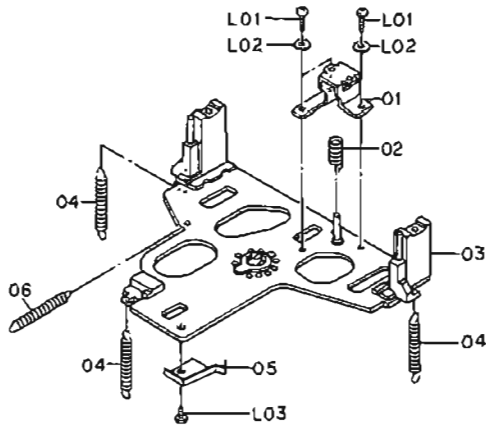

Fig. 5.26

5.27. P-8L Playback Head Ass'y (J01)

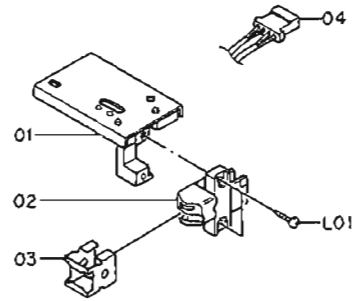

Fig. 5.27

5.28. R-8L Record Head Ass'y (J02)

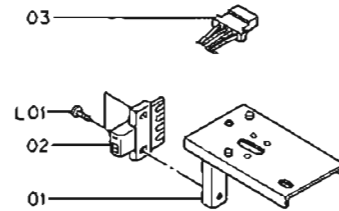

Fig. 5.28

Schematic Ref. No.	Part No.	Description	Qty
I02	CA08464A	Supply Pressure Roller Ass'y Serial No.: A80401001 -	1
01	0C08514A	Pressure Roller	1
02	0C08189C	Supply Tape Guide	1
03	CA08061A	Supply Pressure Roller Arm Sub Ass'y	1
L01	0E00042A	E-Ring 1.5mm	1
L02	0C08024A	Washer 2mm	2
L03	0E00788A	BT 2x8 @ Pan (Black Chromate)	1
I03	CA08465A	Take-up Pressure Roller Ass'y Serial No.: A80401001 -	1
01	0C08514A	Pressure Roller	1
02	0C08181C	Take-up Tape Guide	1
03	CA08073B	Take-up Pressure Roller Arm Sub Ass'y	1
L01	0E00042A	E-Ring 1.5mm	1
L02	0C08024A	Washer 2mm	2
L03	0E00788A	BT 2x8 @ Pan (Black Chromate)	1
I04	CA08530A	Head Base Ass'y Serial No.: A80401001 -	1
01	0C08158D	Erase Head Hold Plate	1
02	0C08166A	Erase Head Hold Plate Spring	1
03	CA08003R	Head Base Ass'y	1
04	0C08175A	Head Base L Spring	3
05	0C08622A	Cassette Hold Spring	1
06	0C08143C	Head Base Drive Arm Spring	1
L01	0E00909A	M2x6 @ Pan (Black Chromate)	3
L02	0E00117A	Washer 2x4.3x0.4	3
L03	0E00853A	BT 2x3 @ Pan (Chromate)	1
J01	CA08526A	P-8L Playback Head Ass'y Serial No.: A80401001 -	1
01	CA08307A	Playback Head Plate	1
02	GA02034A	P-8L Playback Head	1
03	0C08169D	Pad Lifter 54	1
04	0B82195B	4P-H Connector	1
L01	0E00886A	M1.7x6.5 @ Pan (Black Chromate)	2
J02	CA08524A	R-8L Record Head Ass'y Serial No.: A80401001 -	1
01	CA08308B	Record Head Plate	1
02	GA01050A	R-8L Record Head	1
03	0B82196B	4P-H Connector	1
L01	0E00887A	M1.7x4 @ Pan (Black Chromate)	2

6. MOUNTING DIAGRAMS AND PARTS LIST

- Notes: 1. Mounting diagram shows a dip side view of the printed circuit board.
 2. Diode is 1SS53, 1S1555, or 1SS176 unless otherwise specified.
 3. Following transistors are interchangeable with each other.
 a. 2SA733, 2SA608SP, 2SA1048, 2SA1175
 b. 2SC945, 2SC536SP, 2SC2458, 2SC2785
 4. Abbreviation for part name:
 TR — Transistor, SiD — Silicon Diode, GD — Germanium Diode, ZD — Zener Diode
 RK — Carbon Resistor, RM — Metal Film Resistor, RF — Fail Safe Type Resistor, RC — Cement Resistor,
 RW — Wire Wound Resistor
 CE — Electrolytic Capacitor, CM — Mylar Capacitor, CC — Ceramic Capacitor, CP — PP Capacitor,
 CT — Tantalum Capacitor, CM — Film Capacitor, C — Mica Capacitor

6.1. Power Switch P.C.B. Ass'y

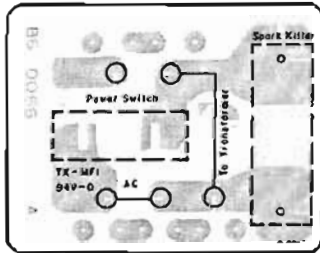

Fig. 6.1

6.2. Fuse P.C.B. Ass'y

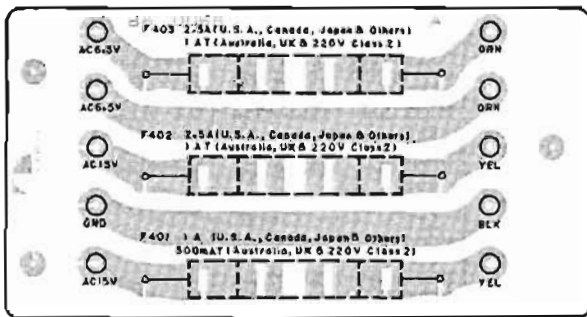

Fig. 6.2

Note: Fuse P.C.B. (OB60068A) is included in DC Power Supply P.C.B. Ass'y. Fuses are included in synthesis mechanism parts list.

6.3. Lid Lamp P.C.B. Ass'y Mounting diagram is omitted.

6.4. TS Pulse P.C.B. Ass'y

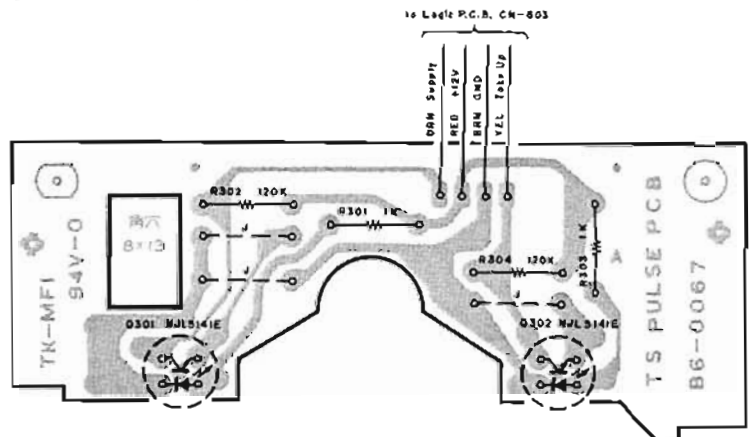

Fig. 6.3

Schematic Ref. No.	Part No.	Description	Schematic Ref. No.	Part No.	Description	Schematic Ref. No.	Part No.	Description
SW1	BA05188A	Power Switch P.C.B. Ass'y (RX505 (U.S.A. & Canada))	PL601 CN610	QJ04789A	Power Switch Holder (1)	Q301,302 R301,303 R302,304	BA05199A	TS Pulse P.C.B. Ass'y
	BA05150A	Power Switch P.C.B. Ass'y (RX505 (Japan))		OE00612A	M3x6 @ Pan (2A) (2)		OB60067A	TS Pulse P.C.B. Photo Reflector NJL 5141E
	BA05189A	Power Switch P.C.B. Ass'y (RX505 (Others & Australia) & RX505E)		OE00752A	Eyelet 2x3 (2)		OB01857A	RK 1K 1/4W J
	OB60066A	Power Switch P.C.B.		OB60065A	Lid Lamp P.C.B.		OB06621A	RK 120K 1/4W J
	OB70002A	Power Switch (1)		OB90010A	Lamp 12V 70 mA		OB82202A	4P-H Connector (1)
	OB08342A	Spark Killer (RX505 (U.S.A. & Canada)) (1)		OB82205A	2P-H Connector			
	OB08363A	Spark Killer (RX505 (Japan)) (1)		OJ04738A	Lamp Holder (1)			
	OB08445A	Spark Killer (RX505 (Others & Australia) & RX505E) (1)						
	OB08359A	Spark Killer Cover (RX505 (Others & Australia) & RX505E) (1)						

6.8. Control P.C.B. A Ass'y

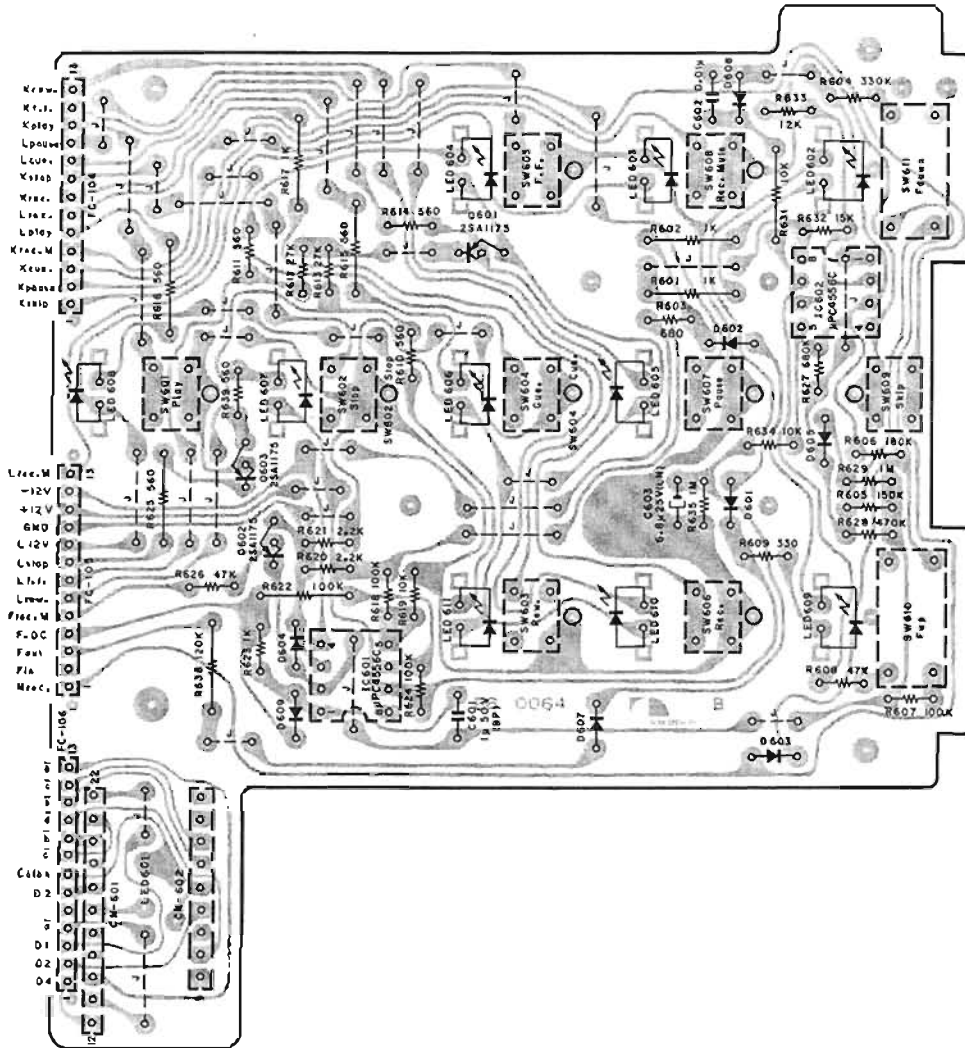

Fig. 6.7

Schematic Ref. No.	Part No.	Description	Schematic Ref. No.	Part No.	Description
	BA05175A	Control P.C.B. A Ass'y	R608,626	OB09717A	RK 47K 1/6W J
			R609	OB09665A	RK 330 1/8W J
IC601,602	OB80064B	Control P.C.B. A	R610,611	OB09671A	RK 560 1/6W J
Q601,602	OB06216A	IC μ PC4656C	614,639		
603	OB06456A	TR 2SA1175	R612,613	OB09711A	RK 27K 1/6W J
LED801	OB06326A	Counter LED	R615,616	OB05575A	RK 560 1/4W J
LED802	OB06333A	LED TLR124A RED	625		
803,809			R619,634	OB09701A	RK 10K 1/6W J
810			R620,621	OB09685A	RK 2.2K 1/6W J
LED804	OB06334A	LED TLR124A GRN	R622	OB01889A	RK 100K 1/4W J
805,806			R623	OB09677A	RK 1K 1/6W J
807,608			R627	OB09745A	RK 680K 1/8W J
811			R628	OB09741A	RK 470K 1/6W J
D601,602	OB06398A	SiD 1S176	R629,635	OB09749A	RK 1M 1/6W J
603,604			R631	OB01888A	RK 10K 1/4W J
606,807			R632	OB09705A	RK 16K 1/6W J
608,609			R633	OB09703A	RK 12K 1/6W J
R601,602	OB01857A	RK 1K 1/4W J	R638	OB05621A	RK 120K 1/4W J
617			C601	OB09187A	CE 1 μ 50V (BP)
R603	OB09673A	RK 680 1/6W J	C602	OB05681A	CM 0.01 μ 50V J
R604	OB09737A	RK 330K 1/6W J	C603	OB40183A	CE 6.8 μ 25V K (LN)
R605	OB08729A	RK 160K 1/6W J	SW601-609	OB70004A	Touch Switch 4.3mm
R606	OB09731A	RK 180K 1/6W J	SW610,611	OB70013A	Tact Switch
R607,618	OB09725A	RK 100K 1/6W J	CN601	OB81017A	IC Socket 11P
624			CN602	OB81016A	IC Socket 9P
				QJ04797A	LED House (10)

6.9. Control P.C.B. B Assy

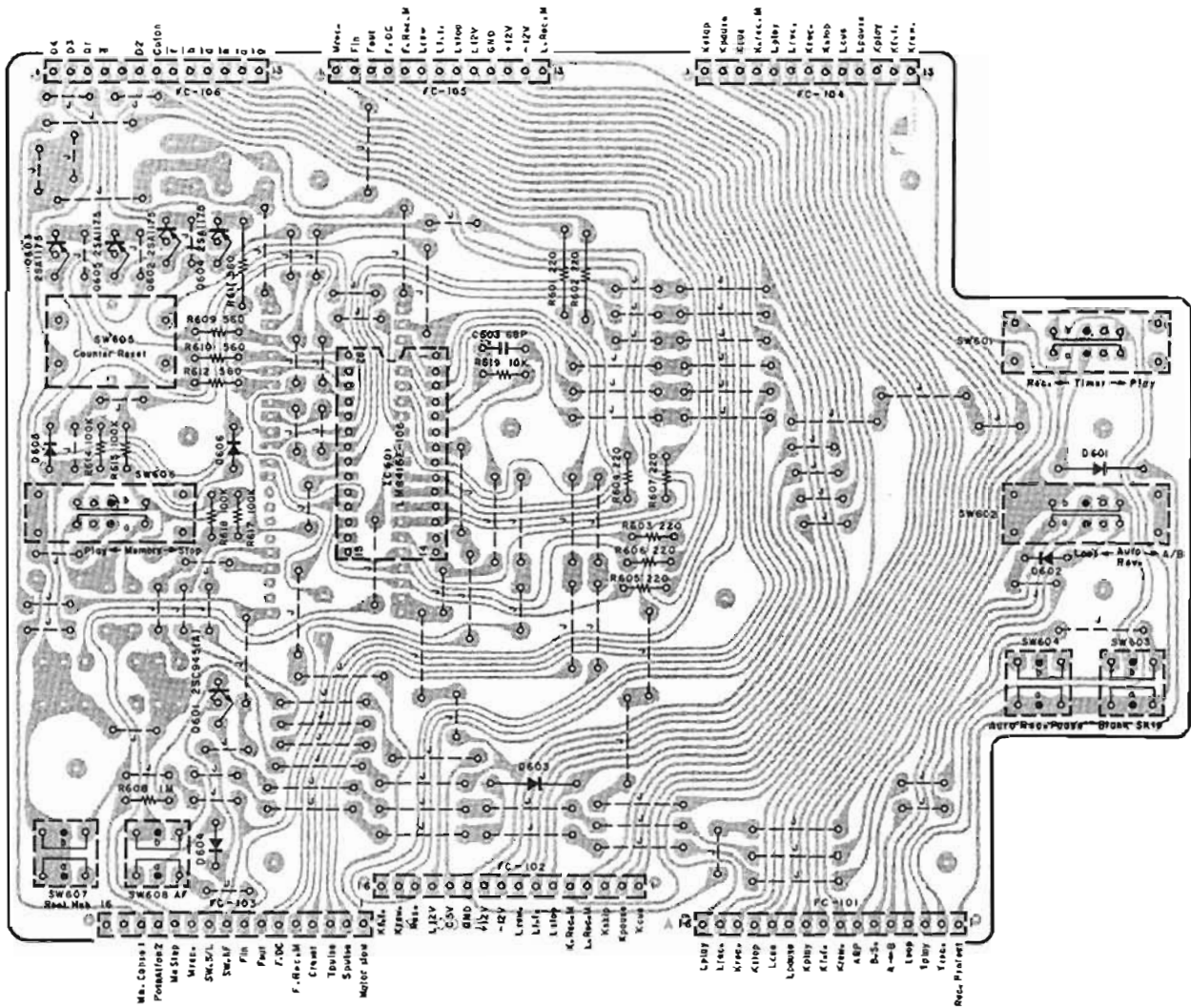

Fig. 6.8

Schematic Ref. No.	Part No.	Description	Schematic Ref. No.	Part No.	Description
	BA05187A	Control P.C.B. B Assy	SW601,602 608	OB07437A	Slide Switch 2-3
	OB60065A	Control P.C.B. B	SW603,604 607,608	OB70014A	Push Switch
IC601	OB08368A	IC LM6416E-108	SW805	OB07459A	Tact Switch
Q801	OB08100A	TR 2SC945A (K,P,Q)	FC101,102 103	OB82197A	Flat Cable 18P
Q802,603 604,605	OB06456A	TR 2SA1175	FC104,105 106	OB82198A	Flat Cable 13P
D801,608	OB08181A	SID 1SS53		OJ04809A	P.C.B. Hmelon (1)
D802,604 605,606	OB08398A	SID 1SS176			
R601,602	OB01933A	RK 220 1/4W J			
R603,604 605,606 607	OB09661A	RK 220 1/6W J			
R608	OB09749A	RK 1M 1/6W J			
R609,610 612	OB09671A	RK 560 1/6W J			
R611	OB05576A	RK 560 1/4W J			
R614,615 617,618	OB09725A	RK 100K 1/6W J			
R619	OB09701A	RK 10K 1/6W J			
C803	OB09893A	CC 68P 50V J			

6.10. DC Power Supply P.C.B. Assy

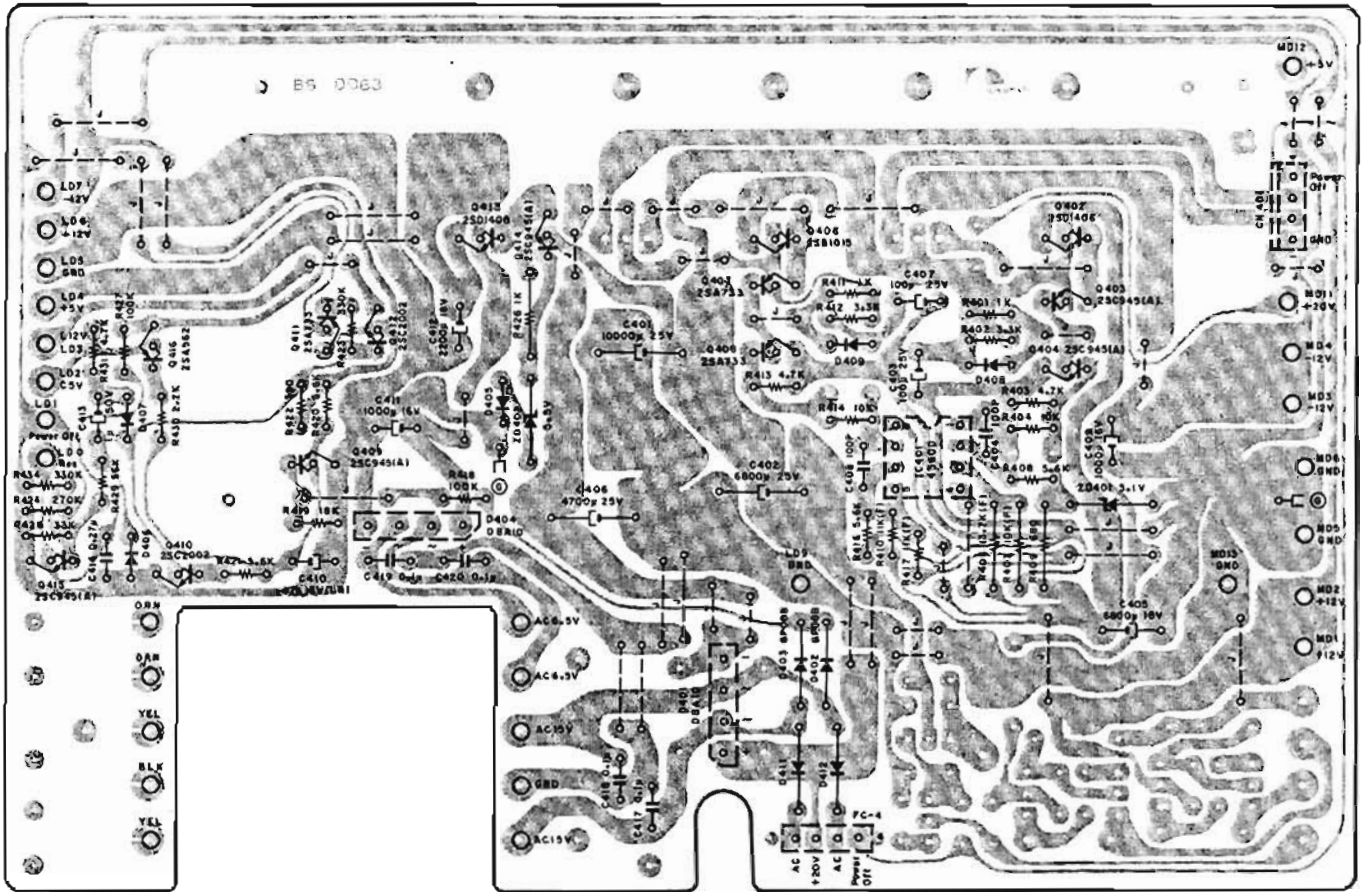

Fig. 6.9

Schematic Ref. No.	Part No.	Description	Schematic Ref. No.	Part No.	Description	Schematic Ref. No.	Part No.	Description
	BA05174A	DC Power Supply P.C.B. Assy	R409	OB05794A	RK 680 1/4W J		OE00607A	M3x8 @ Pan (3A)
			R410,417	OB22847A	RM 11K 1/4W F			(3)
			R418,427	OB09725A	RK 100K 1/8W J		OE00754A	M3x8 @ Pan
	OB600638	DC Power Supply P.C.B.	R419	OB09707A	RK 18K 1/8W J			(1)
			R422	OB08667A	RK 390 1/8W J		OE00608A	M3x10 @ Pan (3A)
			R423,434	OB09737A	RK 330K 1/8W J			(Black Chromate)
			R424	OB09735A	RK 270K 1/8W J			(3)
			R426	OB01857A	RK 1K 1/4W J			
			R428	OB09713A	RK 33K 1/6W J			
			R429	OB09719A	RK 56K 1/6W J			
			R430	OB09685A	RK 2.2K 1/8W J			
	OB06461A	TR 2SB1016 (Y)	C401	OB40179A	CE 10000µ 25V			
	OB06013A	TR 2SA733 (P,Q)	C402	OB09374A	CE 6800µ 25V			
			C403,407	OB01272A	CE 100µ 25V			
	OB06322A	TR 2SC2002 (K,L)	C404,408	OB41071A	CC 100P 50V J			
	OB01428A	TR 2SA562 (O,Y)	C405	OB09798A	CE 6800µ 16V			
	OB12002A	ZD 5.1V RD6.1JB2T	C406	OB09799A	CE 4700µ 25V			
	OB06290A	ZD 5.6V RD6.6EB2	C409,411	OB02387A	CE 2200µ 15V			
	OB06292A	Diode Bridge DAB20	C410	OB09218A	CE 47µ 16V (LN)			
	OB06293A	Diode Bridge DAB20	C412	OB40180A	CE 2200µ 16V			
	OB06109A	SID GP08B	C413	OB01405A	CE 1µ 50V			
	OB06398A	SID 1SS176	C414	OB09873A	CF 0.27µ 50V J			
			C417,418	OB09292A	CC 0.1µ 50V Z			
			419,420					
				OB01011A	DIP Mate 4P			
				OB82177A	4P Flat Cable (1)			
				OB60068A	Fuse P.C.B. (1)			
				OB08759E	Heat Sink (1)			
				OB90005A	Insu-Lock (1)			
				OE00037A	Earth Lug B-5 (1)			
				OE00607A	Nut Hex. M3 (Chromate) (3)			
IC401	OB06217A	IC 4580D						
Q402,413	OB06462A	TR 2SD1408						
Q403,404	OB08100A	TR 2SC946A (K,P,Q)						
409,414								
415								
Q406	OB06461A	TR 2SB1016 (Y)						
Q407,408	OB06013A	TR 2SA733 (P,Q)						
411								
Q410,412	OB06322A	TR 2SC2002 (K,L)						
Q416	OB01428A	TR 2SA562 (O,Y)						
ZD401	OB12002A	ZD 5.1V RD6.1JB2T						
ZD402	OB06290A	ZD 5.6V RD6.6EB2						
D401,404	OB06292A	Diode Bridge DAB20						
D402,403	OB06109A	SID GP08B						
D405,406	OB06398A	SID 1SS176						
407,408								
409								
D411,412	OB06181A	SID 1SS53						
R401,411	OB09677A	RK 1K 1/8W J						
R402,412	OB09689A	RK 3.3K 1/6W J						
R403,413	OB09693A	RK 4.7K 1/6W J						
431								
R404,414	OB09701A	RK 10K 1/8W J						
R406	OB09523A	RM 13.7K 1/4W F						
R407	OB09203A	RM 10K 1/4W F						
R408,416	OB09695A	RK 5.6K 1/6W J						
420,421								

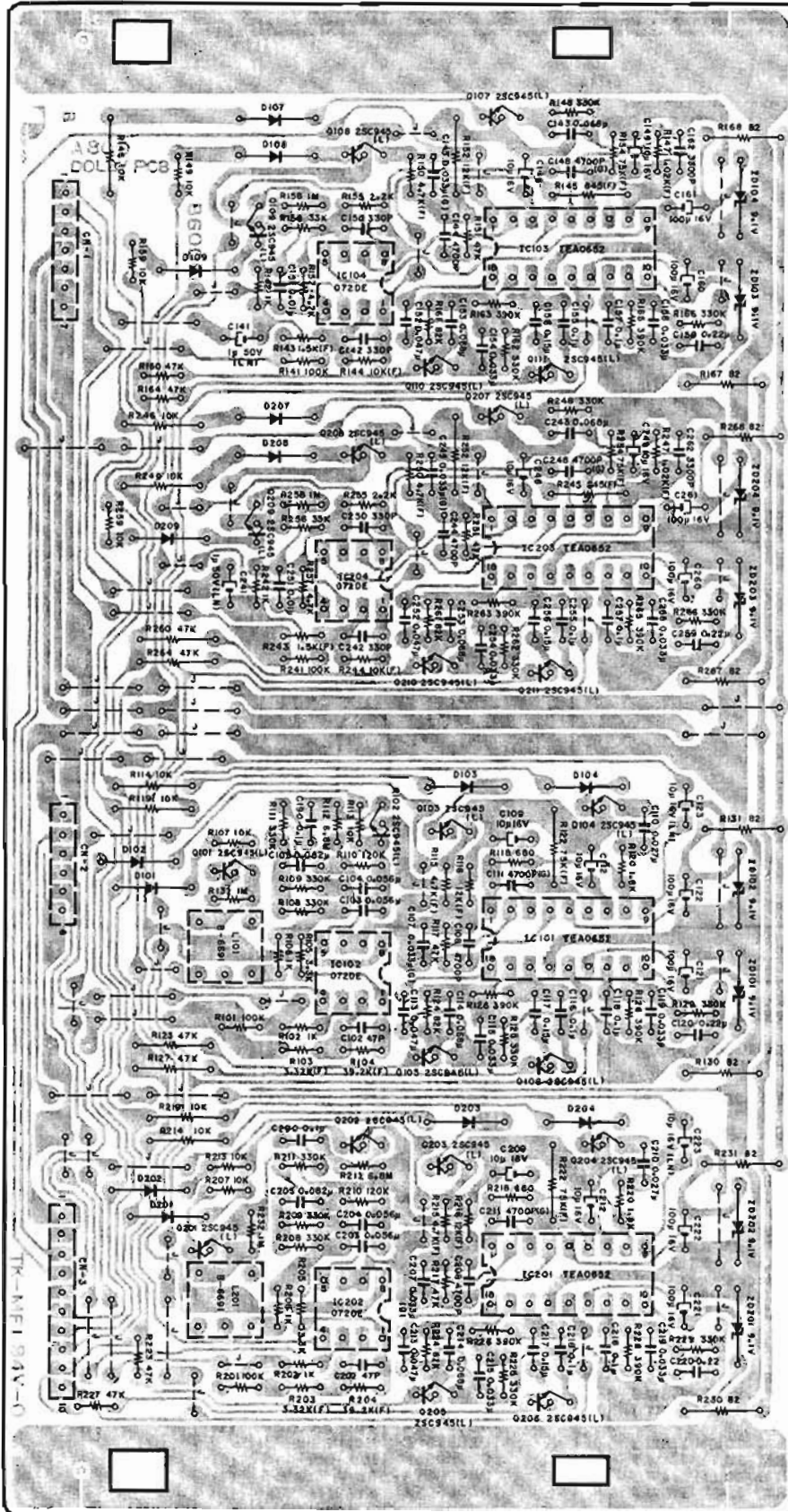

Fig. 8.10

Schematic Ref. No.	Part No.	Description	Schematic Ref. No.	Part No.	Description
	BA05171A	Dolby NR P.C.B. Assy	R148,162 166,248 262,266	OB09737A	RK 330K 1/6W J
	- Encoder -		R149,169 269	OB09701A	RK 10K 1/6W J
IC101,201	OB06382A	IC TEA0652	R150,250	OB22805A	RM 4.7K 1/4W F
IC102,202	OB11005A	IC NJM072DE	R151,180	OB09717A	RK 47K 1/8W J
Q101-106	OB01872A	TR 2SC945L (P,Q)	184,251		
201-206			R152,252	OB22570A	RM 12K 1/4W F
ZD101,102	OB06232A	ZD 9.1V RD9.1EB2	R154,254	OB22443A	RM 75K 1/4W F
201,202			R155,255	OB09885A	RK 2.2K 1/6W J
D101-104	OB06181A	SID 1SS53	R156,256	OB09718A	RK 33K 1/8W J
201-204			R157,257	OB09893A	RK 4.7K 1/8W J
L101,201	OB06691A	L-C Block YEL	R158,258	OB09749A	RK 1M 1/6W J
R101,201	OB09725A	RK 100K 1/6W J	R161,261	OB09723A	RK 82K 1/8W J
R102,106	OB09677A	RK 1K 1/6W J	R163,165	OB09739A	RK 390K 1/6W J
202,206			263,265		
R103,203	OB22287A	RM 3.32K 1/6W F	R167,168	OB09162A	RF 82 1/4W J
R104,204	OB22410A	RM 39.2K 1/6W F	267,268		
R105,205	OB09689A	RK 3.3K 1/6W J	R260,264	OB05641A	RK 47K 1/4W J
R107,113	OB09701A	RK 10K 1/6W J	C141,241	OB09814A	CE 1μ 50V (LN)
207,213			C142,150	OB09322A	CF 330P 100V J
R108,109	OB09737A	RK 330K 1/6W J	242,260		
111,125			C143,153	OB09868A	CF 0.088μ 50V J
129,208			243,253		
209,211			C144,244	OB05652A	CM 4700P 50V J
225,229			C145,245	OB09240A	CF 0.033μ 100V G
R110,210	OB09727A	RK 120K 1/6W J	C146,149	OB01412A	CE 10μ 16V
R112,212	OB09347A	RM 6.8M 1/6W J	246,249		
R114,119	OB01888A	RK 10K 1/4W J	C148,248	OB09191A	CP 4700P 100V G
214,219			C161,261	OB05681A	CM 0.01μ 50V J
R115,215	OB22305A	RM 4.7K 1/4W F	C162,262	OB09864A	CF 0.047μ 50V J
R116,216	OB22351A	RM 12K 1/4W F	C164,168	OB09862A	CF 0.033μ 50V J
R117,217	OB09717A	RK 47K 1/6W J	254,258		
223,227			C155,157	OB09868A	CF 0.1μ 50V J
R118,218	OB09673A	RK 680 1/6W J	255,257		
R120,220	OB09683A	RK 1.8K 1/6W J	C156,256	OB09870A	CF 0.15μ 50V J
R122,222	OB09582A	RM 75K 1/6W J	C259,259	OB09972A	CF 0.22μ 50V J
R123,127	OB05841A	RK 47K 1/4W J	C160,161	OB01400A	CE 100μ 16V
R124,224	OB09723A	RK 82K 1/6W J	260,261		
R126,128	OB09739A	RK 390K 1/6W J	C162,262	OB01914A	CM 3300P 50V J
226,228				- Miscellaneous -	
R130,131	OB09162A	RF 82 1/4W J		OB60061B	Dolby NR P.C.B.
230,231				OB81106A	7P-S Post
R132,232	OB09749A	RK 1M 1/6W J	CN1	OB81105A	8P-S Post
C102,202	OB09242A	C 47P 50V J	CN2	OB81109A	10P-S Post
C103,104	OB09865A	CF 0.056μ 50V J	CN3	OB04795A	P.C.B. Holder (2)
203,204					
C105,205	OB09867A	CF 0.082μ 50V J			
C107,207	OB09240A	CF 0.033μ 100V G			
C108,208	OB05652A	CM 4700P 50V J			
C109,112	OB01412A	CE 10μ 16V			
209,212					
C110,210	OB09046A	CM 0.027μ 50V J			
C111,211	OB09191A	CP 4700P 100V G			
C113,213	OB09864A	CF 0.047μ 50V J			
C114,214	OB09866A	CF 0.068μ 50V J			
C115,119	OB09862A	CF 0.033μ 50V J			
215,219					
C116,118	OB09868A	CF 0.1μ 50V J			
190,218					
218,290					
C117,217	OB09870A	CF 0.15μ 50V J			
C120,220	OB09872A	CF 0.22μ 50V J			
C121,122	OB01400A	CE 100μ 16V			
221,222					
C123,223	OB09816A	CE 10μ 16V (LN)			
	- Decoder -				
IC103,203	OB06382A	IC TEA0652			
IC104,204	OB11005A	IC NJM072DE			
Q107-111	OB01872A	TR 2SC945L (P,Q)			
207-211					
ZD103,104	OB06232A	ZD 9.1V RD9.1EB2			
203,204					
D107,108	OB06181A	SID 1SS53			
109,207					
208,209					
R141,241	OB09725A	RK 100K 1/6W J			
R142,242	OB09677A	RK 1K 1/6W J			
R143,243	OB22247A	RM 1.5K 1/4W F			
R144,244	OB09929A	RM 10K 1/4W F			
R145,245	OB22549A	RM 845 1/4W F			
R146,246	OB01888A	RK 10K 1/4W J			
249					
R147,247	OB22230A	RM 1.02K 1/4W F			

Schematic Ref. No.	Part No.	Description	Schematic Ref. No.	Part No.	Description	Schematic Ref. No.	Part No.	Description
	HA08173A	Logic P.C.B. Assy	R634,958	OB09707A	RK 18K 1/6W J		OE00607A	Nut Hex. M3 (Chromate) (2)
IC601	OB80062B	Logic P.C.B.	R636,646	OB09889A	RK 3.3K 1/6W J		OE00621A	M3x8 @ Fan (Black Chromate) (2)
IC602	OB11019A	IC LM6402G-261	678,957				OJ04485A	Heat Sink B (1)
IC603	OB11025A	IC LM6402G-282	R642	OB22420A	RM 47.5K 1/6W F			
IC604,607	OB11040A	IC LM6417E-338	R643	OB22515A	RM 332K 1/6W F			
IC605	OB06124B	IC NJM4558D	R644	OB01887A	RK 5.6K 1/4W J			
IC806	OB06317A	IC μ PD4030BC	R645,661	OB09899A	RK 8.2K 1/6W J			
Q602,803	OB06143A	IC μ PD4001BC	R647,689	OB09703A	RK 12K 1/6W J			
610,614	OB06100A	TR 2SC945A (K,P,Q)	R648,670	OB09723A	RK 82K 1/6W J			
615,616			R649	OB22444A	RM 76.8K 1/6W F			
617,618			R650	OB06509A	RK 33K 1/4W J			
620,621			R651,652	OB09713A	RK 33K 1/6W J			
628,627			665,688					
629,630			698,699					
633,634			R654,967	OB09731A	RK 180K 1/6W J			
Q604,606	OB06013A	TR 2SA733 (P,Q)	R655	OB05615A	RK 22K 1/4W J			
806,807			R656,657	OB09927A	RM 100K 1/6W F			
619,622			R659,663	OB06671A	RK 2.2M 1/4W J			
Q608,611	OB06316A	TR 2SD882 (P,Q)	684,933					
624			R660	OB09214A	RF 1 1/4W J			
Q609,612	OB06303A	TR 2SB772 (P,Q)	R662,932	OB09793A	RK 220K 1/6W J			
625			952					
Q613,632	OB06202A	TR 2SA562TM (Y)	R664,938	OB09727A	RK 120K 1/6W J			
Q623	OB06129A	FET 2SK117	R666	OB09716A	RK 43K 1/6W J			
WD601	OB12100A	Double SID MC921	R667,675	OB09885A	RK 2.2K 1/6W J			
D602-608	OB06398A	SID 1SS176 (23)	926,928					
608			939					
611-613			R671,921	OB01889A	RK 100K 1/4W J			
616-620			R672	OB09697A	RK 6.8K 1/6W J			
623-631			R673,951	OB09893A	RK 4.7K 1/6W J			
D607,609	OB06181A	SID 1SS53	R674	OB09861A	RK 220 1/6W J			
610,614			R676,963	OB09821A	RF 4.7 1/4W J			
615,621			R880	OB09741A	RK 470K 1/6W J			
622			R681	OB22493A	RM 220K 1/6W F			
X601	OB08908A	Xtal 400 kHz	R682	OB09300A	RM 150K 1/4W F			
X602	OB90009A	Xtal 4.1943 MHz	R683	OB09315A	RM 332K 1/4W F			
T601	OB51047A	Bias Osc. Block	R686,911	OB09709A	RK 22K 1/6W J			
VR601	OB07257A	Semi-fixed VR 100K	927,929					
VR602,607	OB07329A	Semi-fixed VR 2K	R690,893	OB09745A	RK 680K 1/6W J			
VR603,608	OB07256A	Semi-fixed VR 10K	R691,894	OB09747A	RK 820K 1/6W J			
VR604	OB07405A	Semi-fixed VR 200K	937,938					
VR605	OB07289A	Semi-fixed VR 50K	R908,954	OB09695A	RK 5.6K 1/6W J			
R605,628	OB09717A	RK 47K 1/6W J	R912	OB09719A	RK 56K 1/6W J			
668			R917	OB09749A	RK 1M 1/6W J			
R607,608	OB09737A	RK 330K 1/6W J	R930	OB09726A	RK 110K 1/6W J			
609,610			R945	OB22506A	RM 280K 1/6W F			
611,612			R946,947	OB22531A	RM 453K 1/6W F			
613,627			R948	OB22470A	RM 133K 1/6W F			
628,640			R955	OB09677A	RK 1K 1/6W J			
641,686			R956	OB09671A	RK 560 1/6W J			
889,892			R960	OB09831A	RF 22 1W J			
910,986			R961	OB09936A	RF 10 1/2W J			
R614,615	OB09749A	RK 1M 1/6W J	R962	OB01867A	RK 1K 1/4W J			
629,697			R964	OB09705A	RK 15K 1/6W J			
698,901			C601,603	OB01412A	CE 10 μ 16V			
902,931			621,622					
942,944			C605	OB06557A	CM 0.015 μ 50V J			
R616,621	OB06776A	RK 1M 1/4W J	C606,607	OB06552A	CM 4700P 50V J			
R617,619	OB09701A	RK 10K 1/6W J	617					
622,636			C608,609	OB09283A	CC 220P 60V K			
653,679			C610,611	OB01402A	CE 4.7 μ 25V			
909,914			C612	OB01502A	CE 330 μ 16V			
918,920			C613,623	OB09277A	CC 10P 50V J			
959			C614,615	OB01405A	CE 1 μ 50V			
R618,620	OB09725A	RK 100K 1/6W J	C618	OB09372A	CE 2.2 μ 50V			
637,638			C618	OB01863A	CE 3.3 μ 60V			
639,658			C619	OB09279A	CC 22P 50V K			
687,695			C620	OB41187A	CC 39P 50V J			
903,904			C624	OB09639A	CP 0.018 μ 100V G			
905,906			C626	OB01400A	CE 100 μ 16V			
913,915			C626	OB09187A	CE 1 μ 50V (BP)			
916,922			C627	OB09147A	CE 3.3 μ 60V (LN)			
923,941			C628	OB09292A	CC 0.1 μ 60V Z			
943,953			CN601	OB08653A	3P-T Post			
965			CN602	OB08642A	6P-T Post			
R623,677	OB01888A	RK 10K 1/4W J	CN603	OB08654A	4P-T Post			
940			CN604	OB81023A	2P-T Post			
R624,625	OB06627A	RK 330K 1/4W J	CN605,607	OB08656A	2P-T Post			
907			CN606	OB08724A	5P-T Post			
R630,934	OB09711A	RK 27K 1/6W J	CN608	OB02356A	JP Connector 12P			
935			CN609	OB08644A	8P-T Post			
R631,632	OB06743A	RK 27K 1/4W J	CN610	OB02280A	2P-T Post			
R633	OB09712A	RK 30K 1/6W J		OB81086A	Wire Mate 3P (6)			
				OB08964A	TR Mica TO-126 (2)			

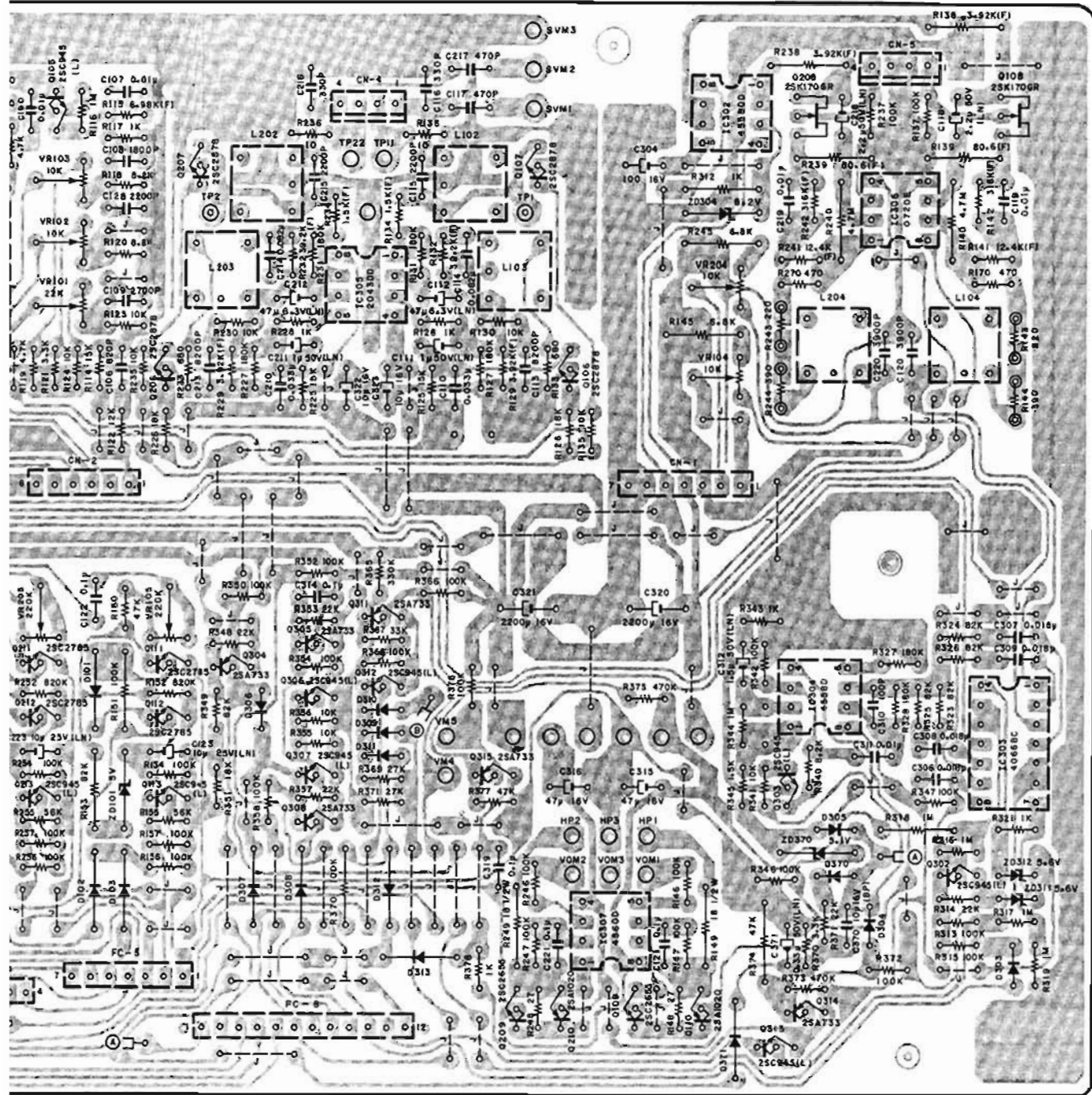

Fig. 6.12

6.13. Main P.C.B. Assy

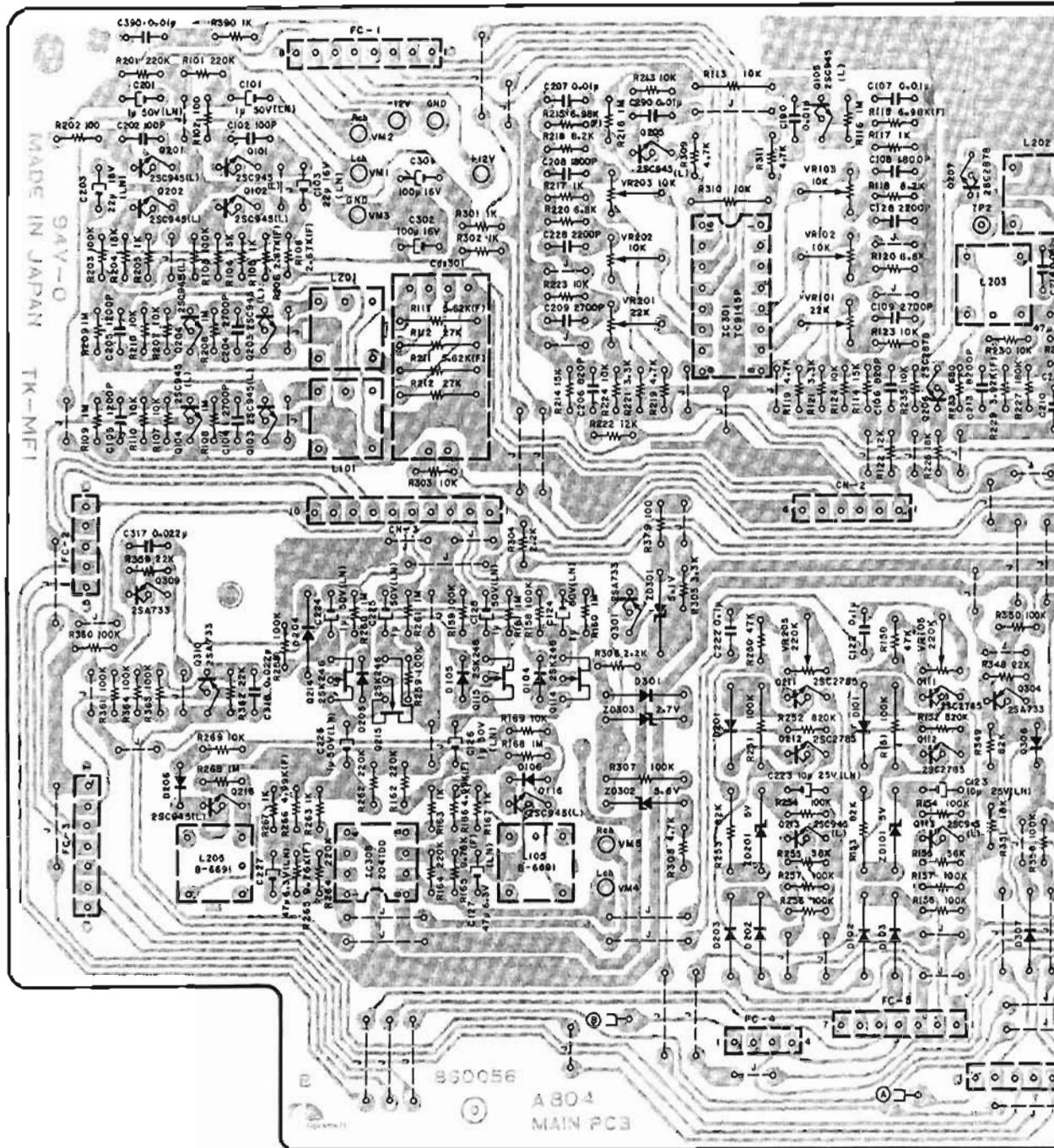

Fig. 6.12

7. SCHEMATIC DIAGRAMS

7.1. Attention to Servicemen

(1) Caution

- If a part is in need of removing (or replacing) for service, it should be remounted (or replaced with specified parts) by the same methods as before after servicing.
- The appliance should be used only specified parts for preventing a risk of fire and electric shock and maintaining the characteristics.
- Before returning the repaired appliance to a customer, check to insure that the exposed part is accurately insulated from the Power Supply by measuring the leakage current or the insulation resistance between them.

(2) Parts Replacement

Following parts shall be replaced with the specified ones. Refer to the Parts List.

- Power Supply Circuit**
Power Cord
Power Transformer: T1
- Power Switch P.C.B. Ass'y**
Power Switch: SW1
Spark Killer: M2
- Fuse P.C.B. Ass'y**
Fuses: F401, 402, 403
- DC Power Supply P.C.B. Ass'y**
Transistors: Q402, 406, 413, 416
Diode Bridges: D401, 404
- Logic P.C.B. Ass'y**
Transistor: Q608, 809, 611, 612, 624, 625
Fail Safe Type Resistors: R660, 676, 960, 961, 963
- Main P.C.B. Ass'y**
Fail Safe Type Resistors: R149, 249
- Dolby NR P.C.B. Ass'y**
Fail Safe Type Resistors: R130, 131, 167, 168, 230, 231, 267, 268

7.2. IC Block Diagrams

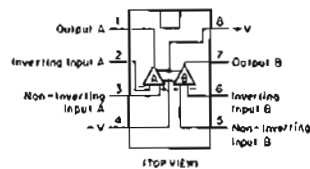

Fig.7.2.1 Operational Amp. IC 4558D, 4558DD, 4556C, 4560D, 2041DD, 2043DD, 072DE

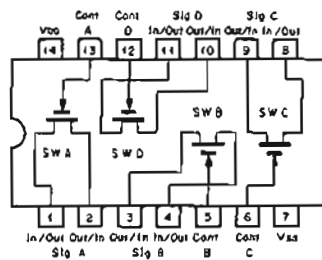

Fig. 7.2.2 Bilateral Switch C-MOS IC μ PD4068BC

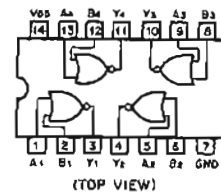

Fig. 7.2.3 NOR Gate C-MOS IC μ PD4001BC

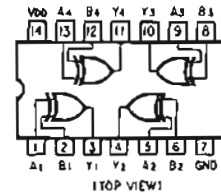

Fig. 7.2.4 Exclusive OR Gate C-MOS IC μ PD4030BC

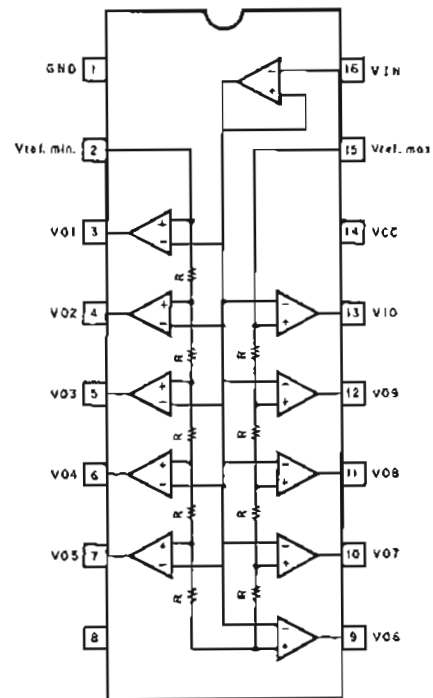

Fig. 7.2.5 Level Meter Driver TA7612AP

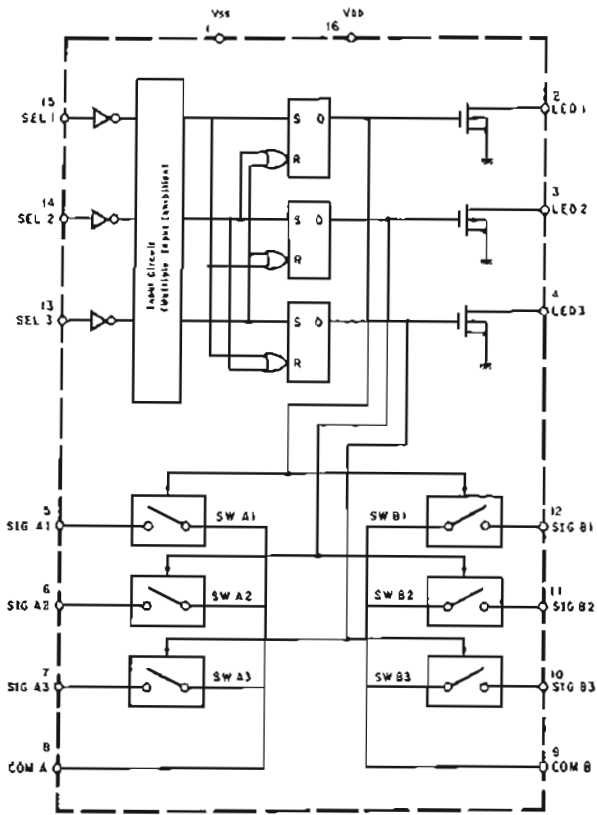

Fig. 7.2.8 Analog Switch Selector TC9145P

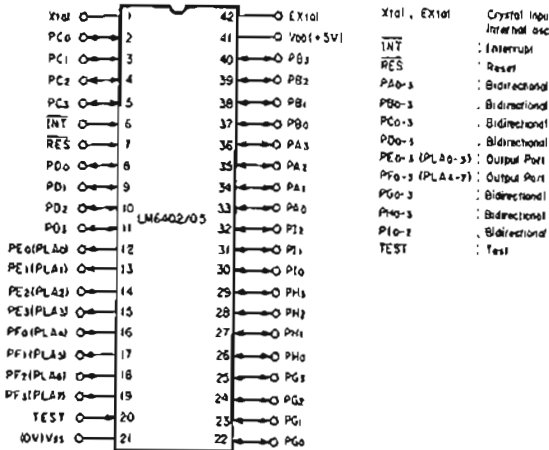
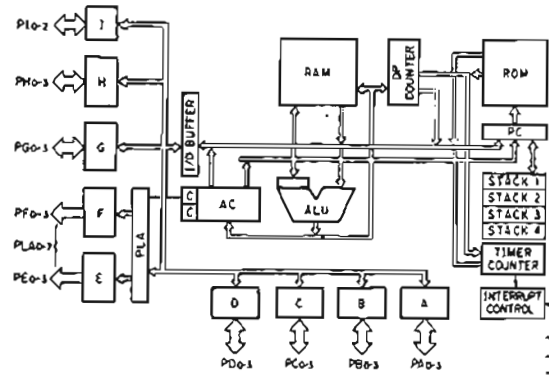

Fig. 7.2.8 4-Bit Micro-processor LM6402G

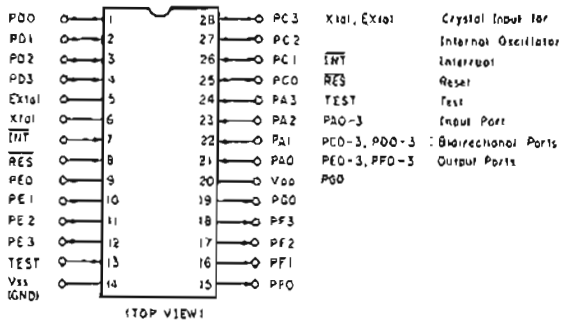
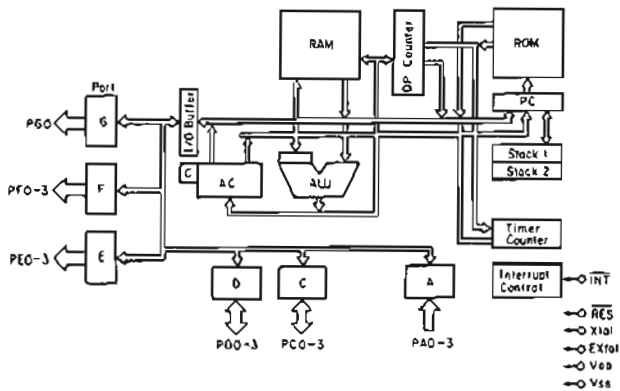

Fig. 7.2.7 4-Bit Micro-processor LM6416E-106

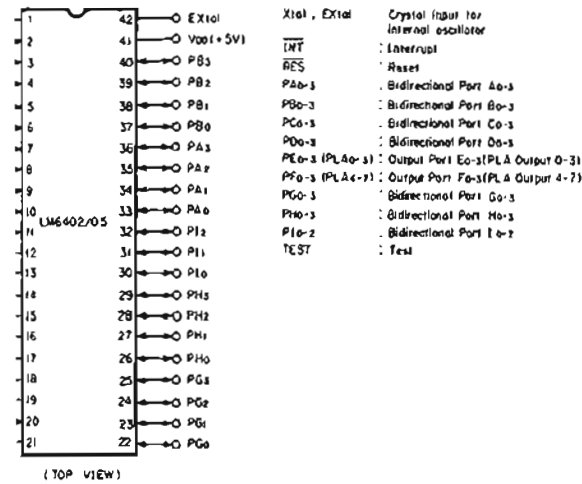
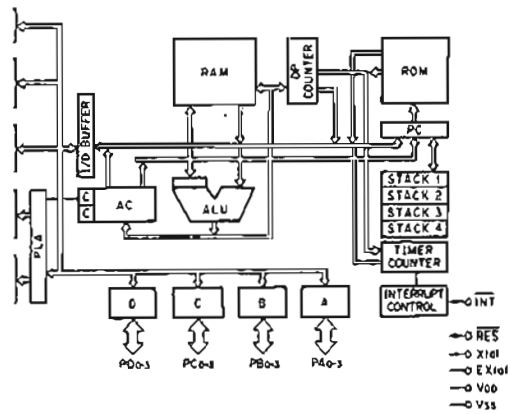

Fig. 7.2.8 4-Bit Micro-processor LM6402G

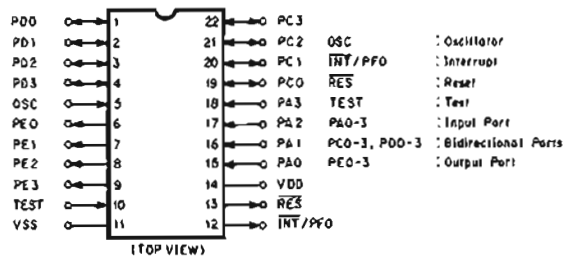
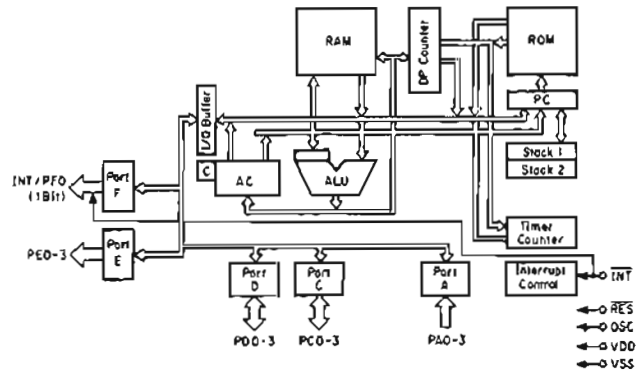
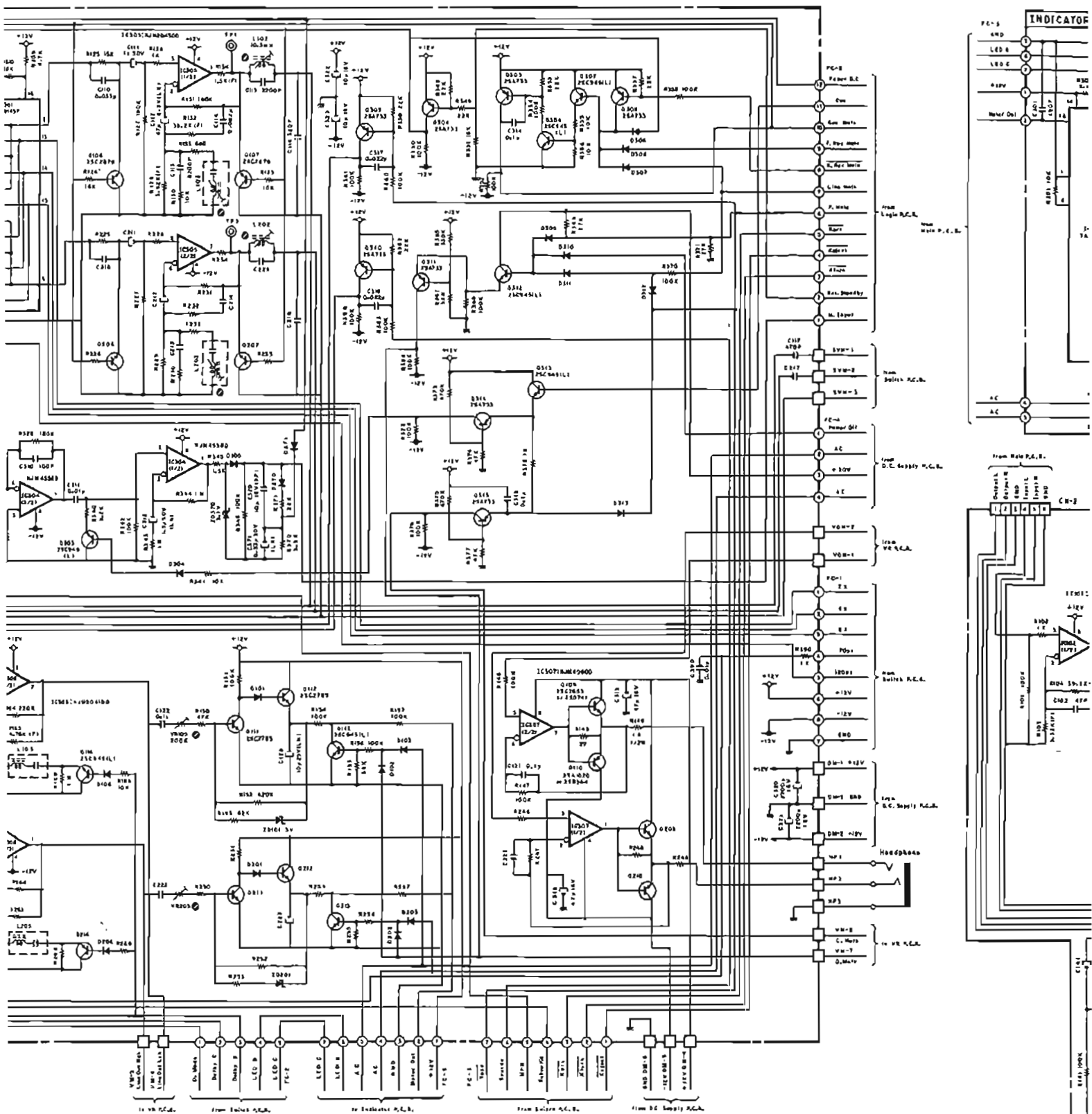
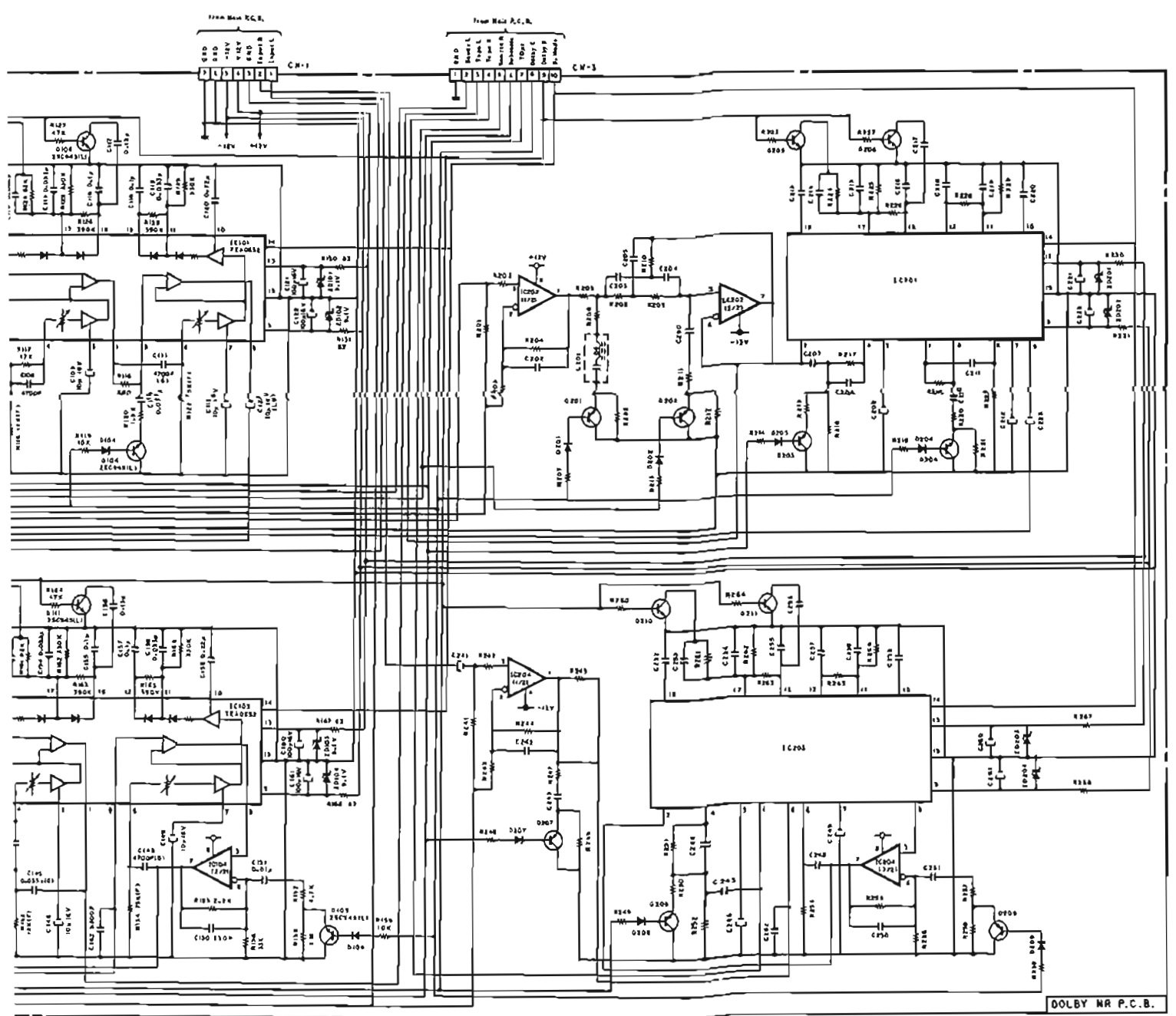
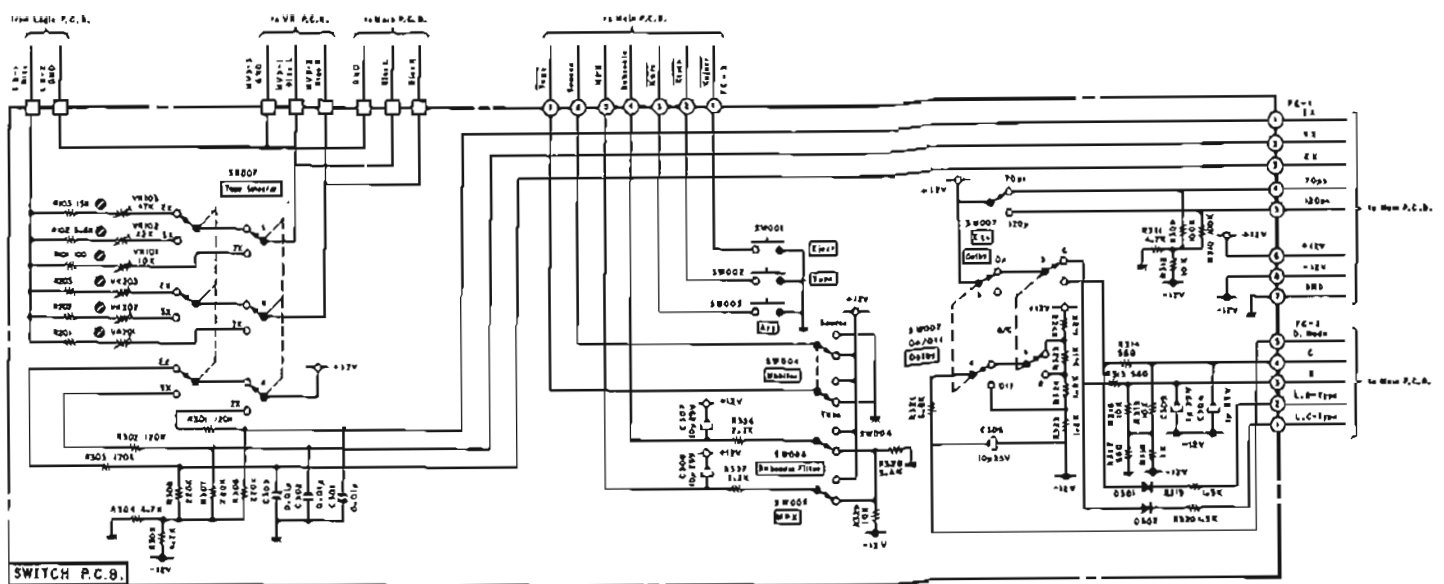

Fig. 7.2.9 4-Bit Micro-processor LM6417E-338



Diode is 1SS53, 1S1555, or 1SS176 unless otherwise specified.
 Resistor and capacitor marked with * show typical value.
 2SA733, 2SA608SP, 2SA1048 and 2SA1175 are interchangeable with each other.
 2SC945, 2SC536SP, 2SC2458 and 2SC2785 are interchangeable with each other.

Fig. 7.3.1



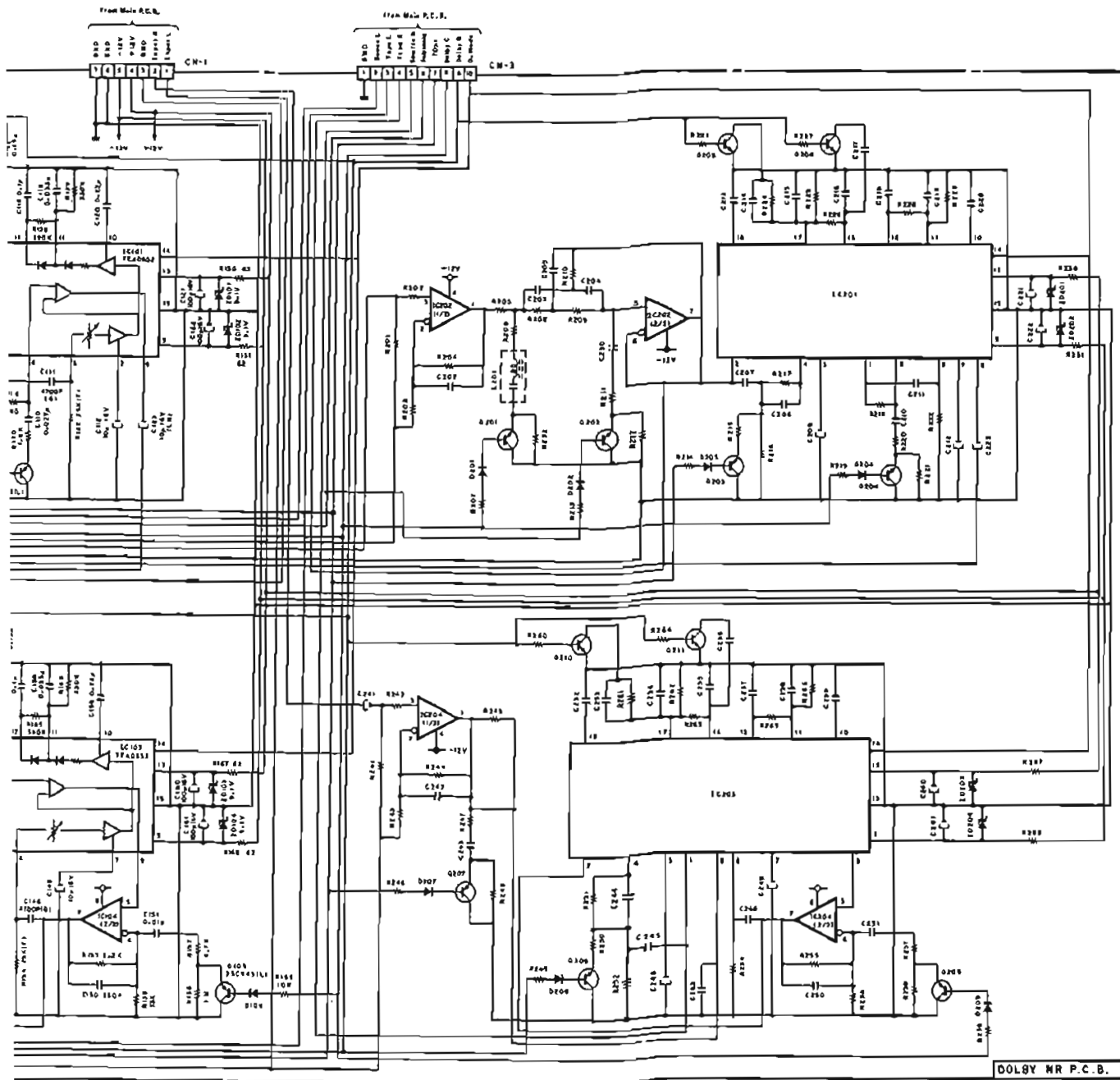
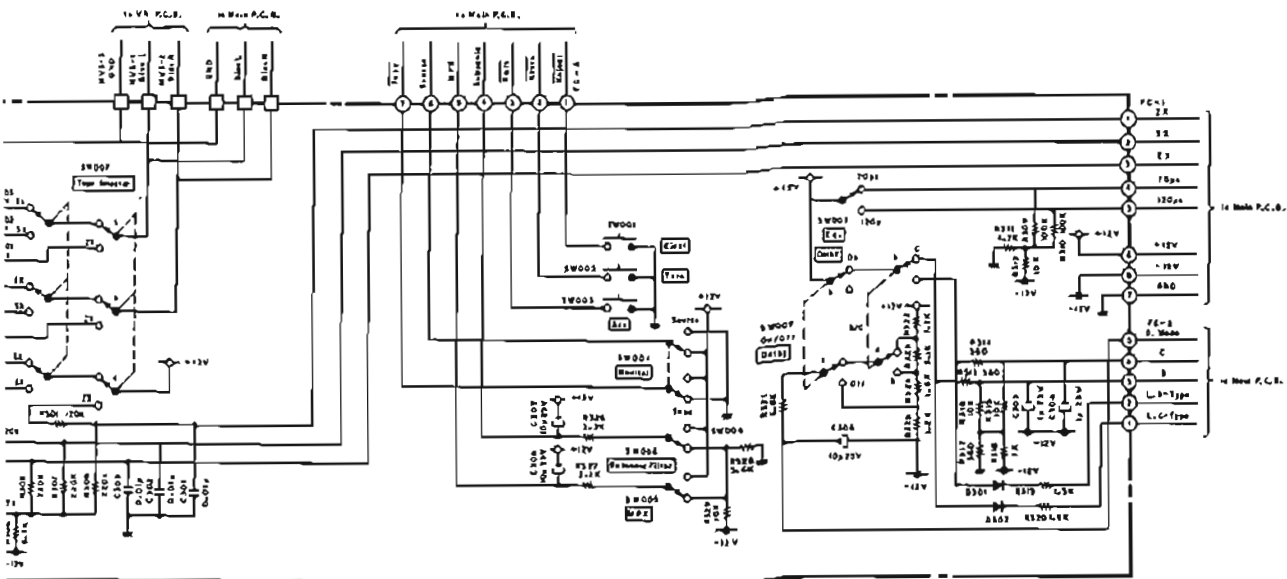

7.3.2. Mechanism Control Section

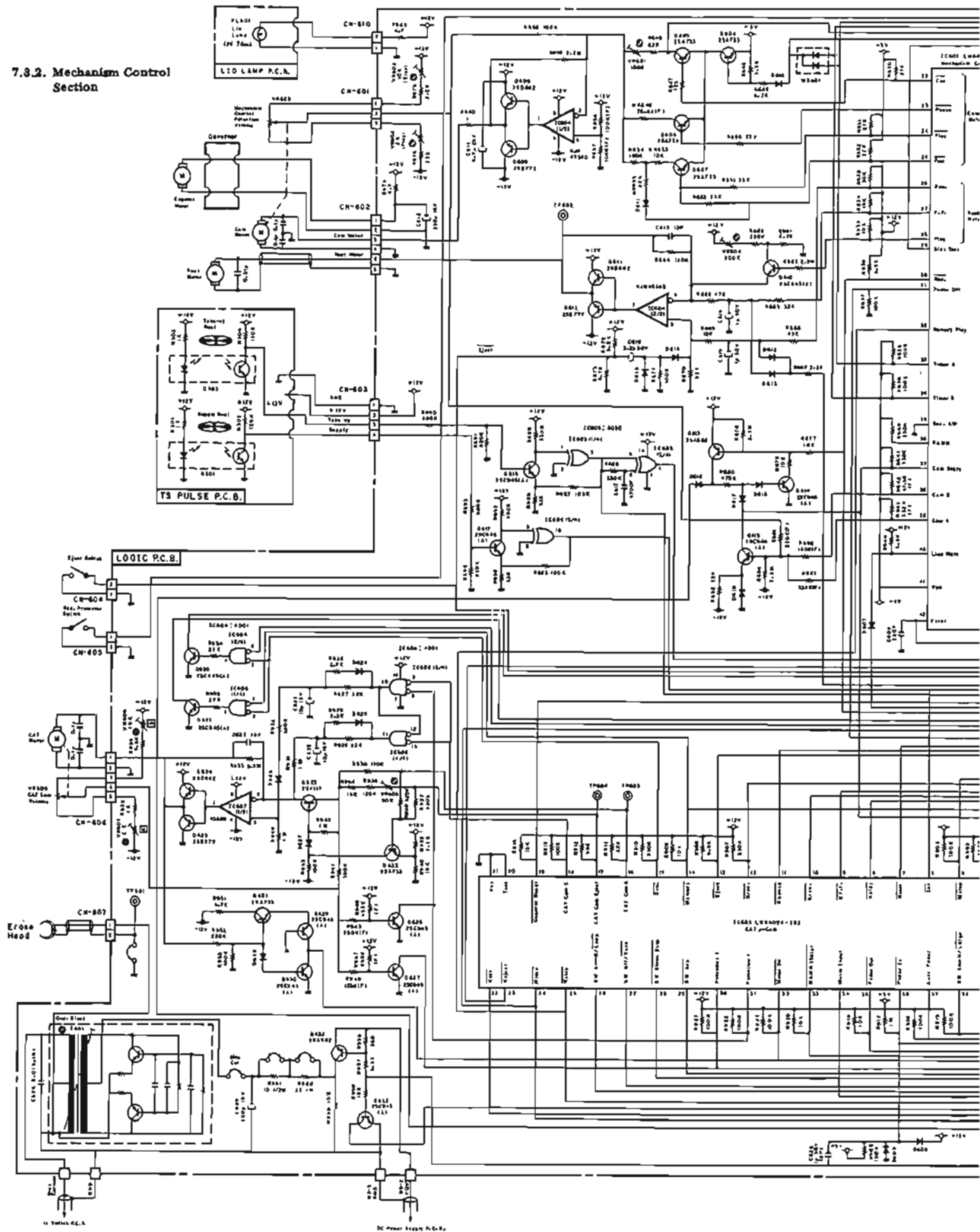

- Notes:
1. Diode is 1SS53, 1S1555, or 1SS176 unless otherwise specified.
 2. Resistor and capacitor marked with * show typical value.
 3. 2SA733, 2SA608SP, 2SA1048 and 2SA1175 are interchangeable with each other.
 4. 2SC945, 2SC536SP, 2SC2458 and 2SC2785 are interchangeable with each other.

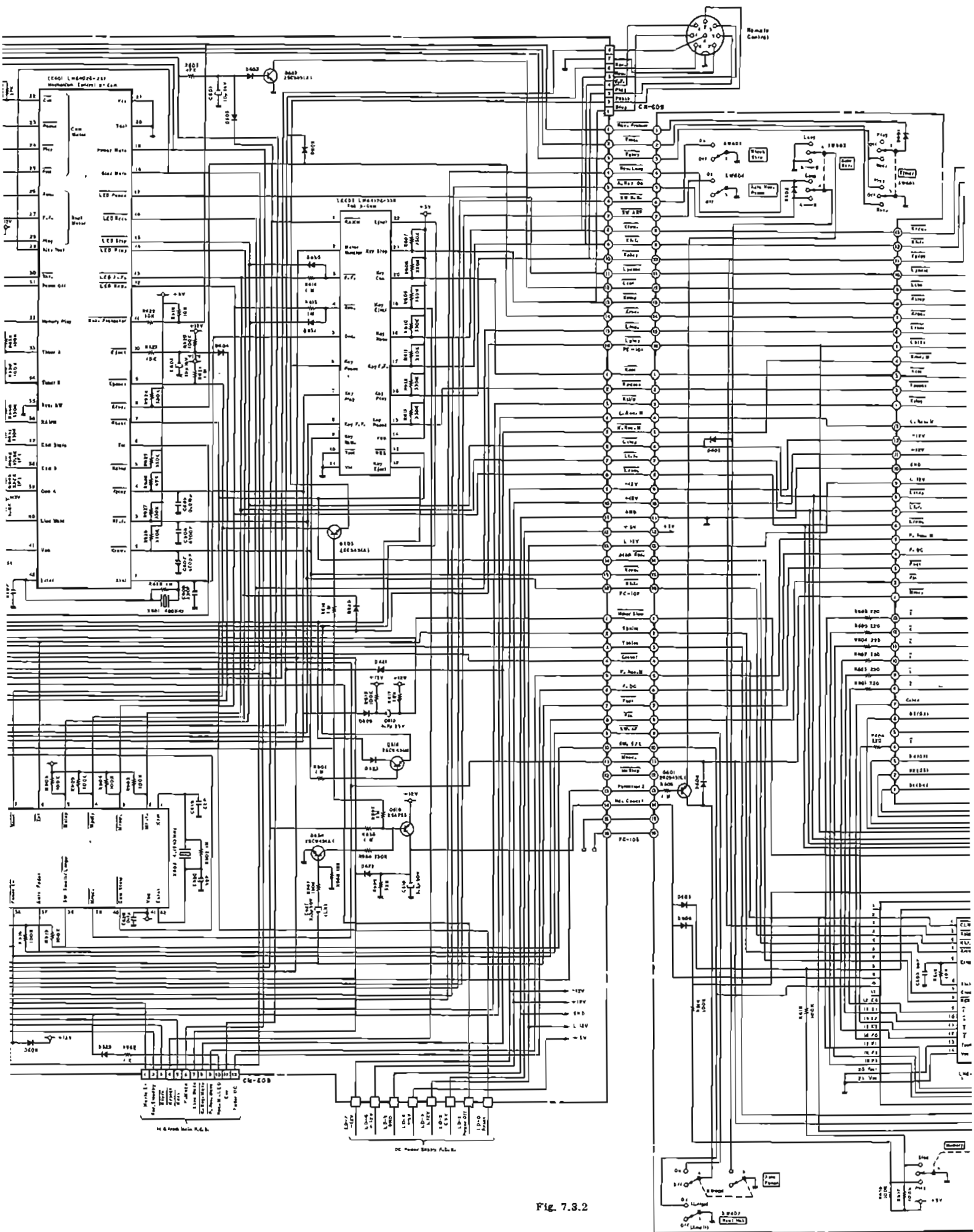

Fig. 7.3.2

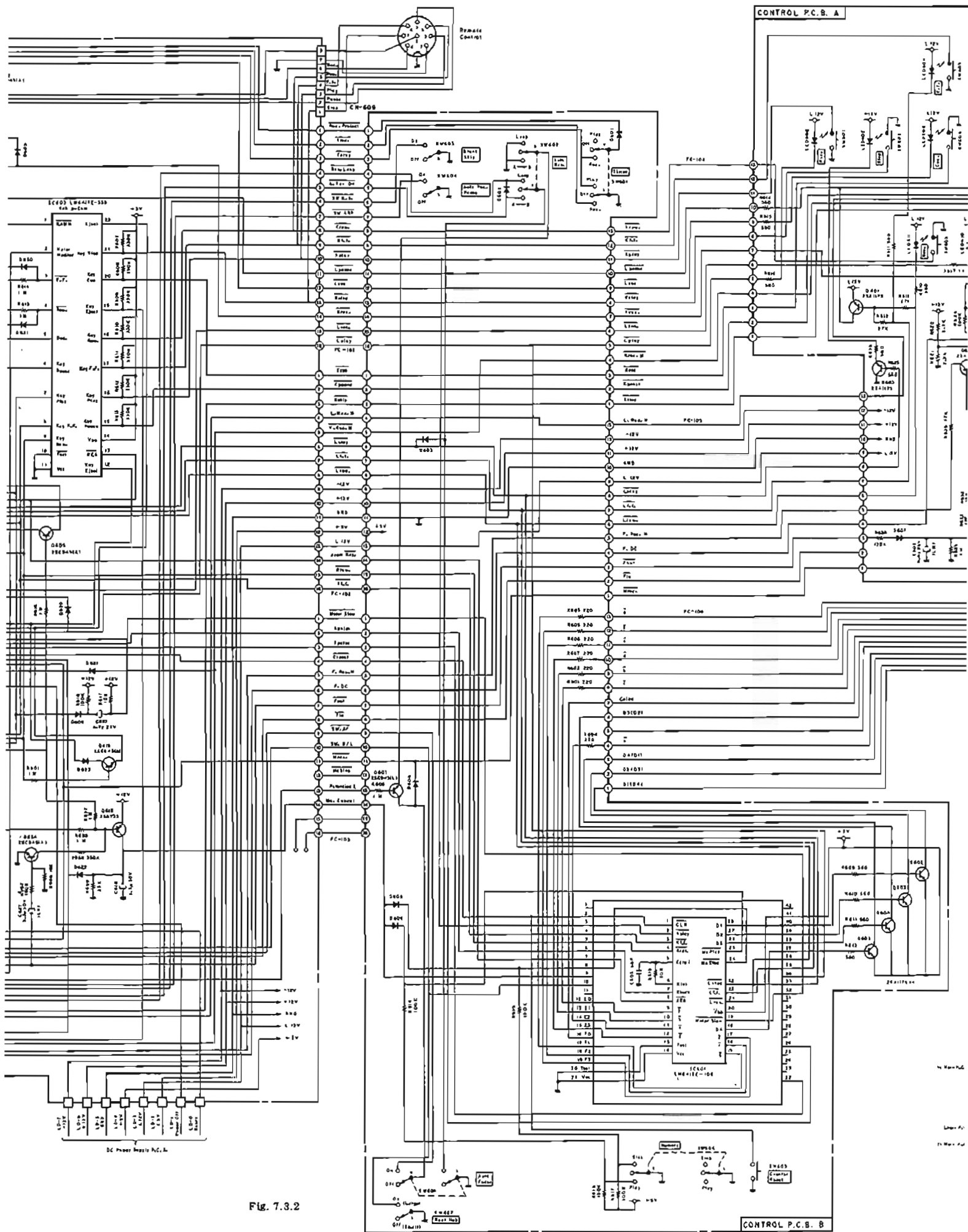
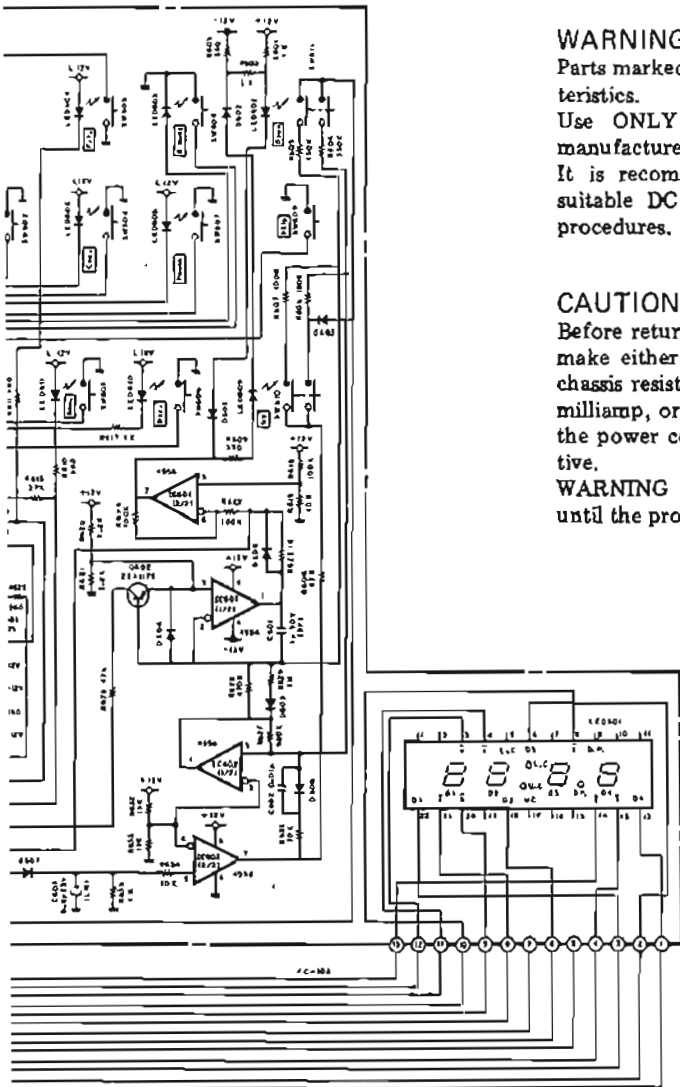



Fig. 7.3.2



WARNING:

Parts marked with the symbol  have critical characteristics. Use ONLY replacement parts recommended by the manufacturer.

It is recommended that the unit be operated from a suitable DC supply or batteries during initial check-out procedures.

CAUTION:

Before returning the unit to the customer, make sure you make either (1) a leakage current check or (2) a line to chassis resistance check. If the leakage current exceeds 0.5 milliamp, or if the resistance from chassis to either side of the power cord is less than 240 k ohms, the unit is defective.

WARNING — DO NOT return the unit to the customer until the problem is located and corrected.

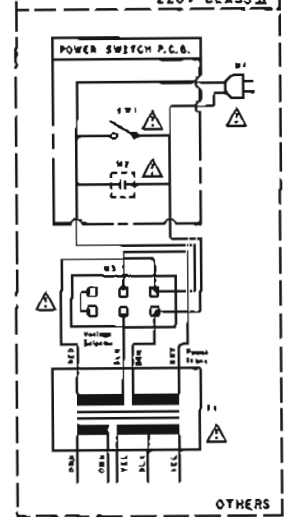
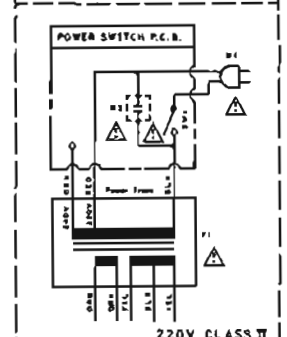
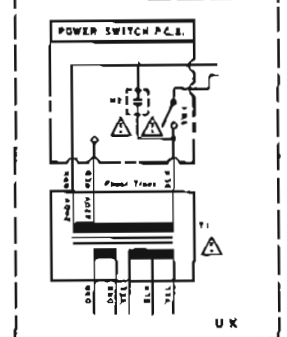
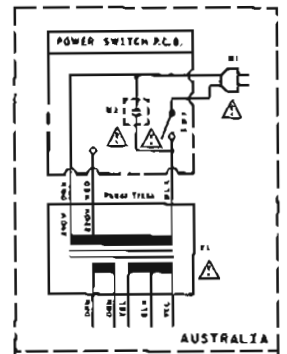
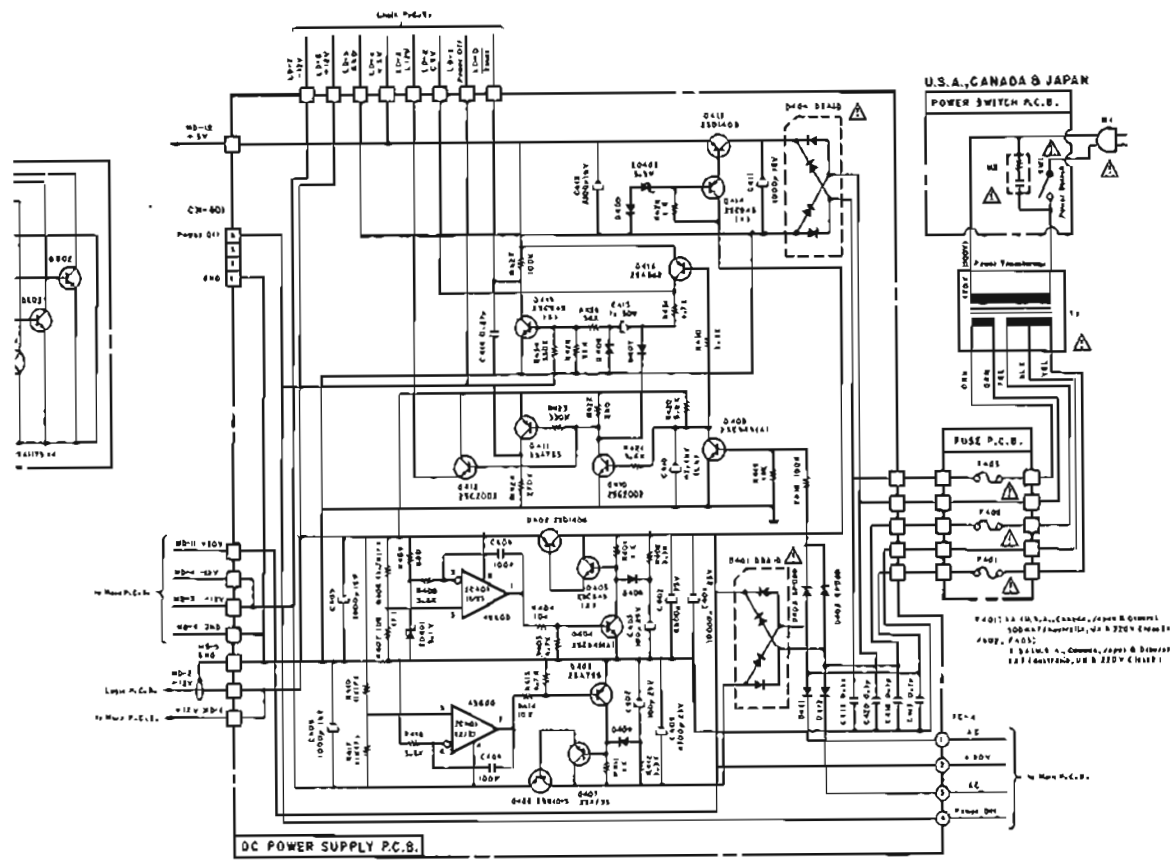

© 1971 by IBM Corp., Chicago, Illinois 60611
 500 Main Street, New York, New York 10011
 P.O. Box 1
 100 Main Street, Cambridge, Massachusetts 02142
 100 Constitution Avenue, Washington, D.C. 20540

8. TIMING CHART AND EQ. AMP. FREQUENCY RESPONSE

8.1. Overall Timing Chart

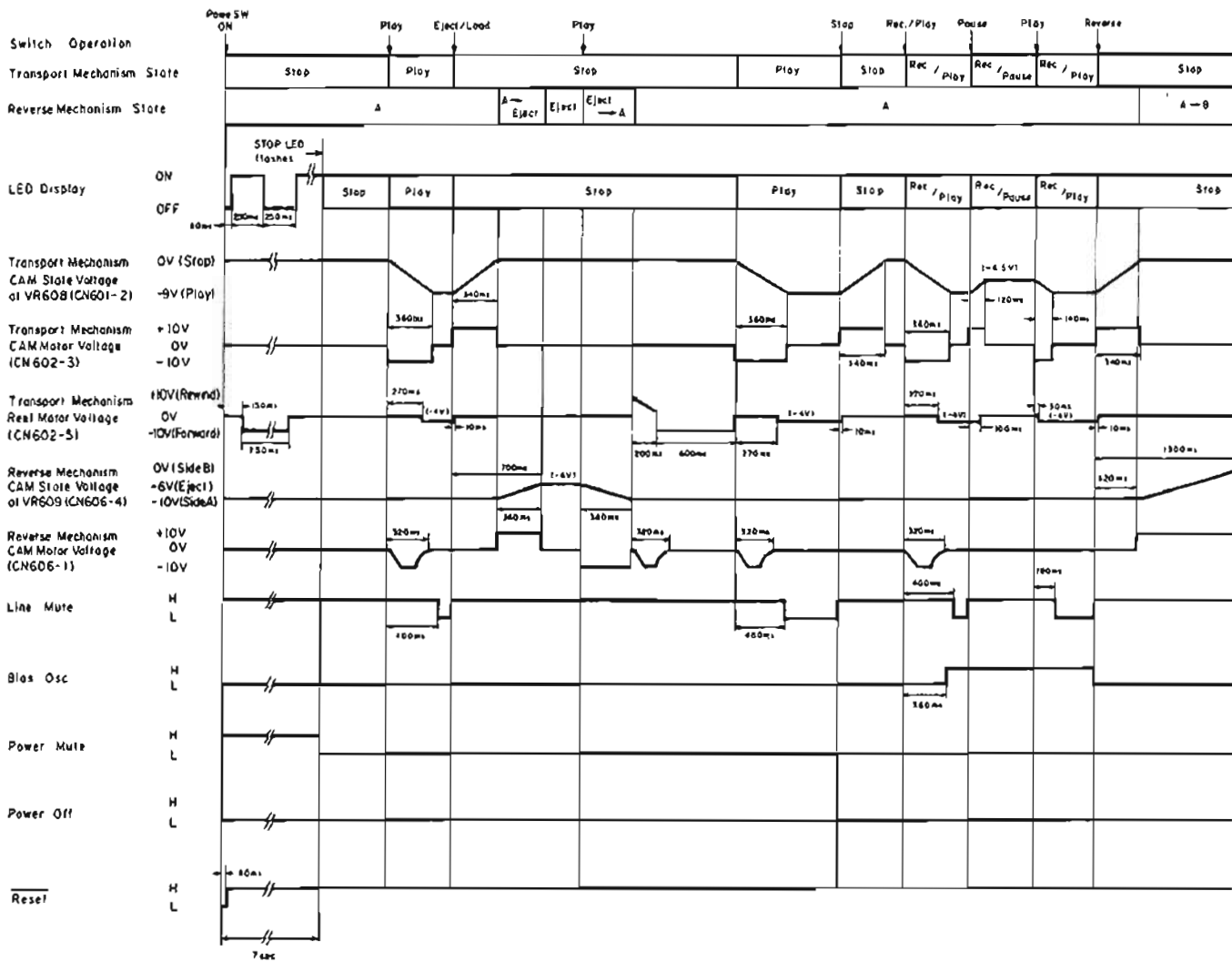

Fig. 8.1

8.2. Eq. Amp. Frequency Response

(1) Playback Frequency Response

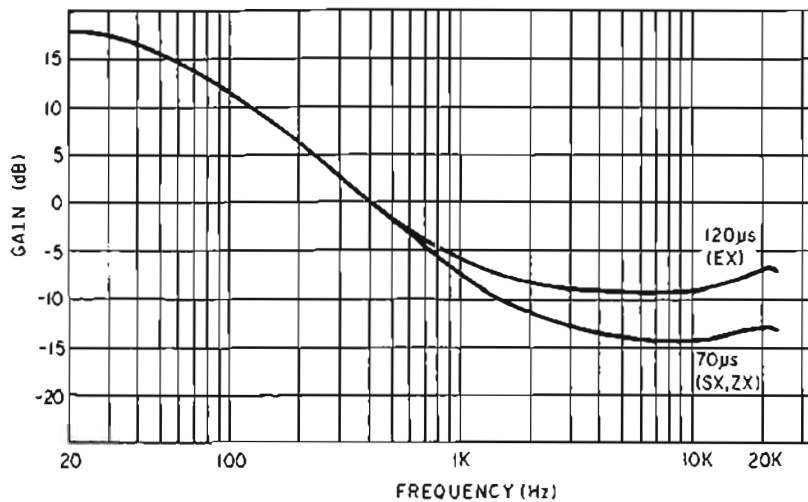
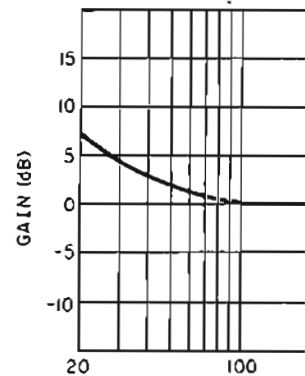
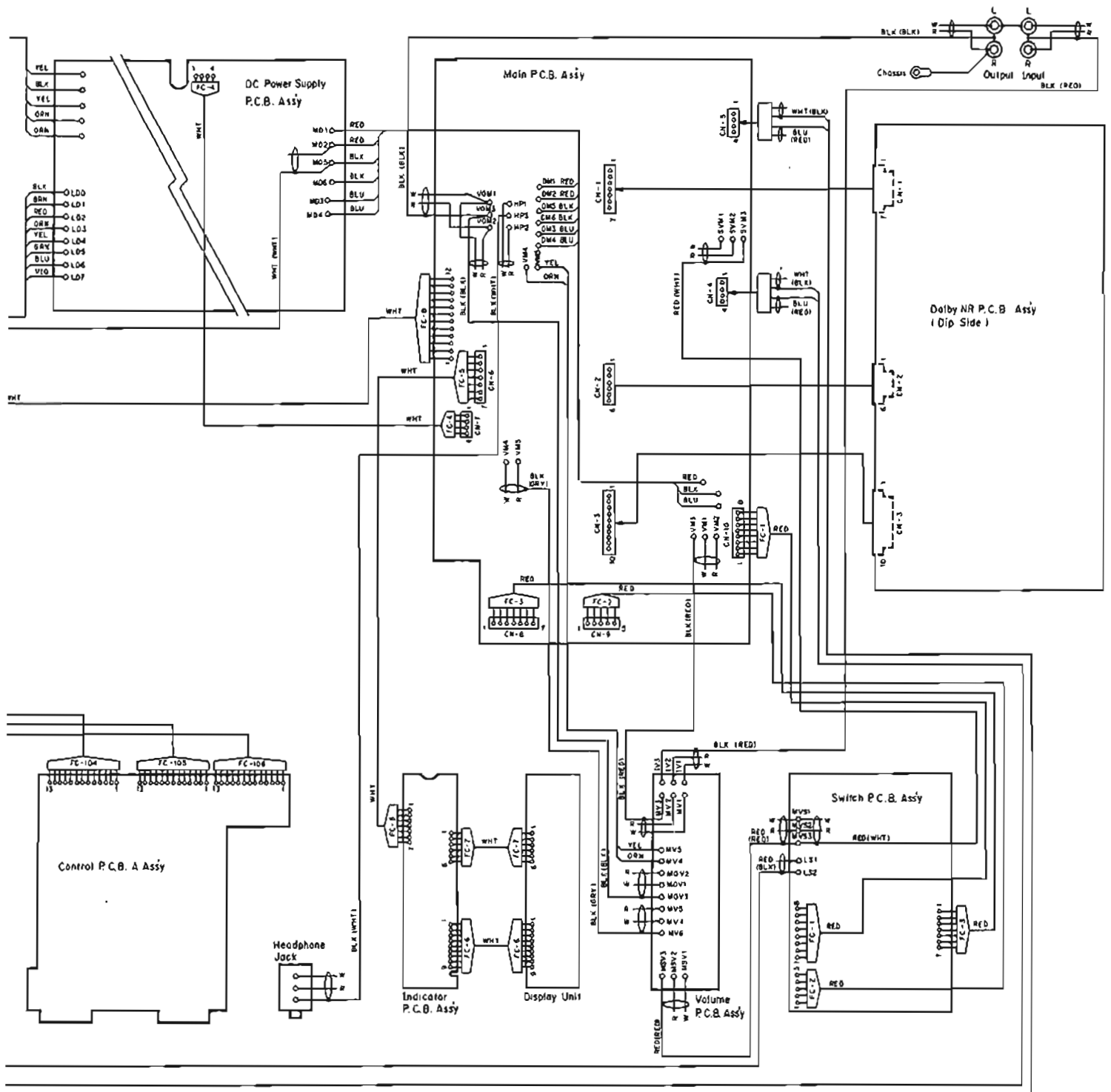

Fig. 8.2.1

(2) Record Current Frequency 1





Notes: 1. Table of wire colors

BRN — Brown	BLU — Blue
RED — Red	VIO — Violet
ORN — Orange	GRY — Gray
YEL — Yellow	WHT — White
GRN — Green	BLK — Black

2. Component side view of the P.C.B. is illustrated unless otherwise specified.

3. Wire tube color is shown in ().

10. BLOCK DIAGRAMS

10.1. Amplifier Section

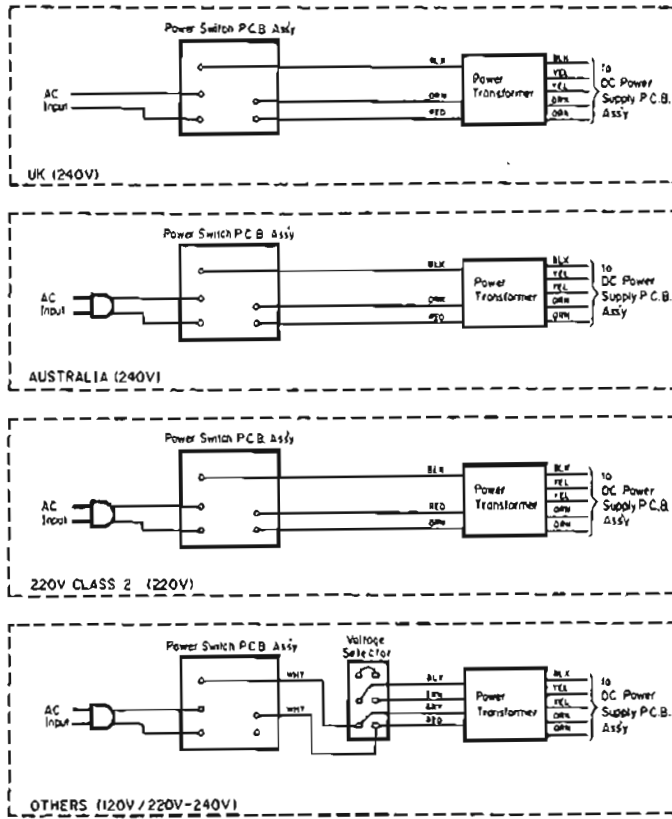
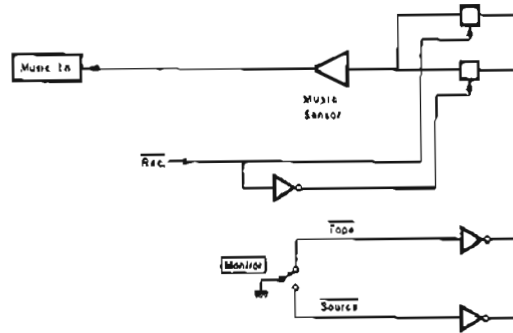
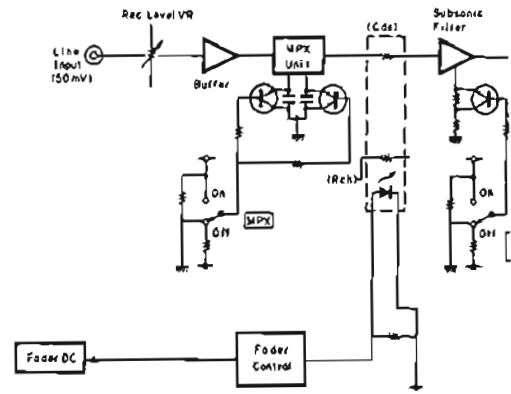

Fig. 9.2



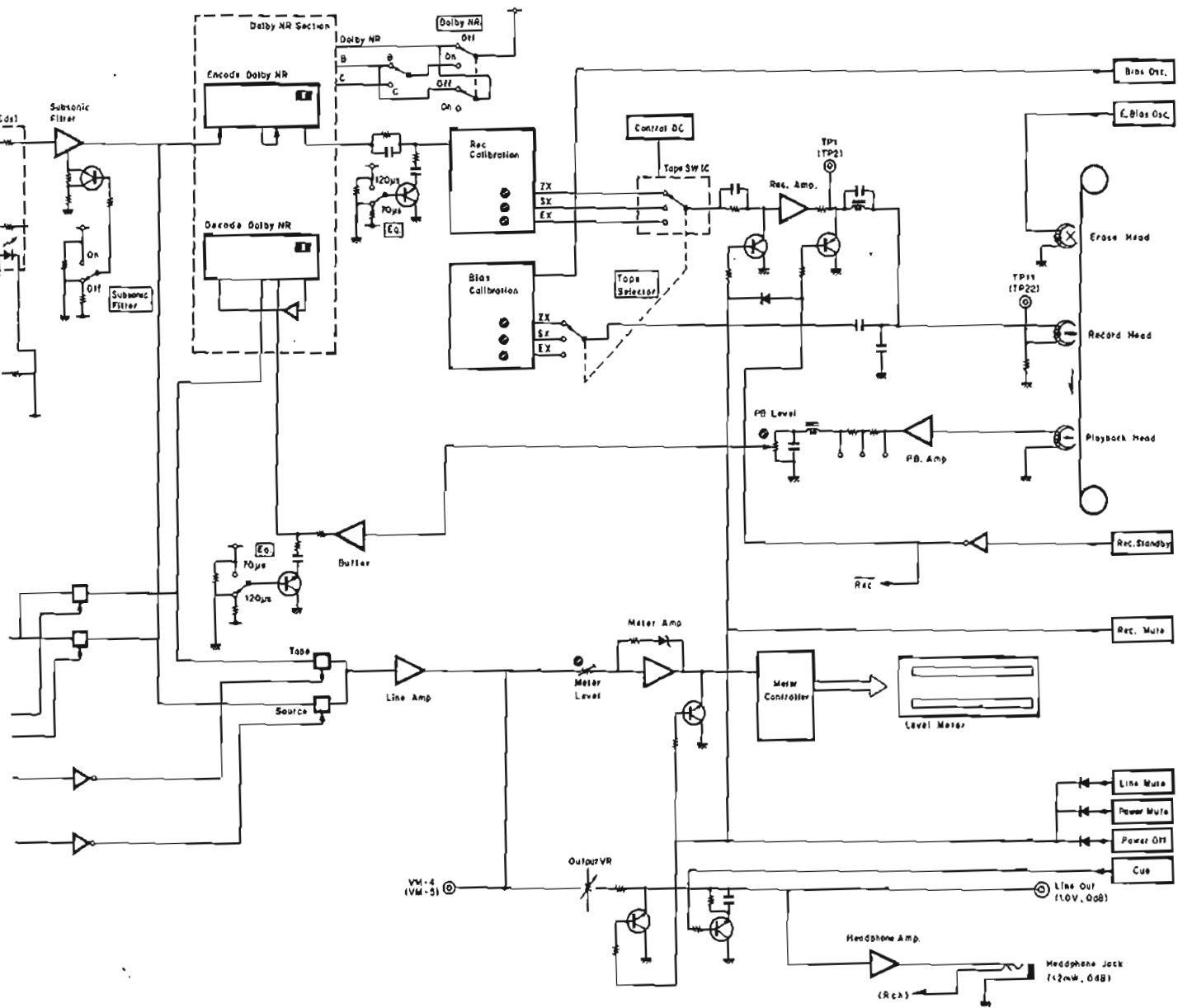

Fig. 10.1

10.2. Mechanism Control Section

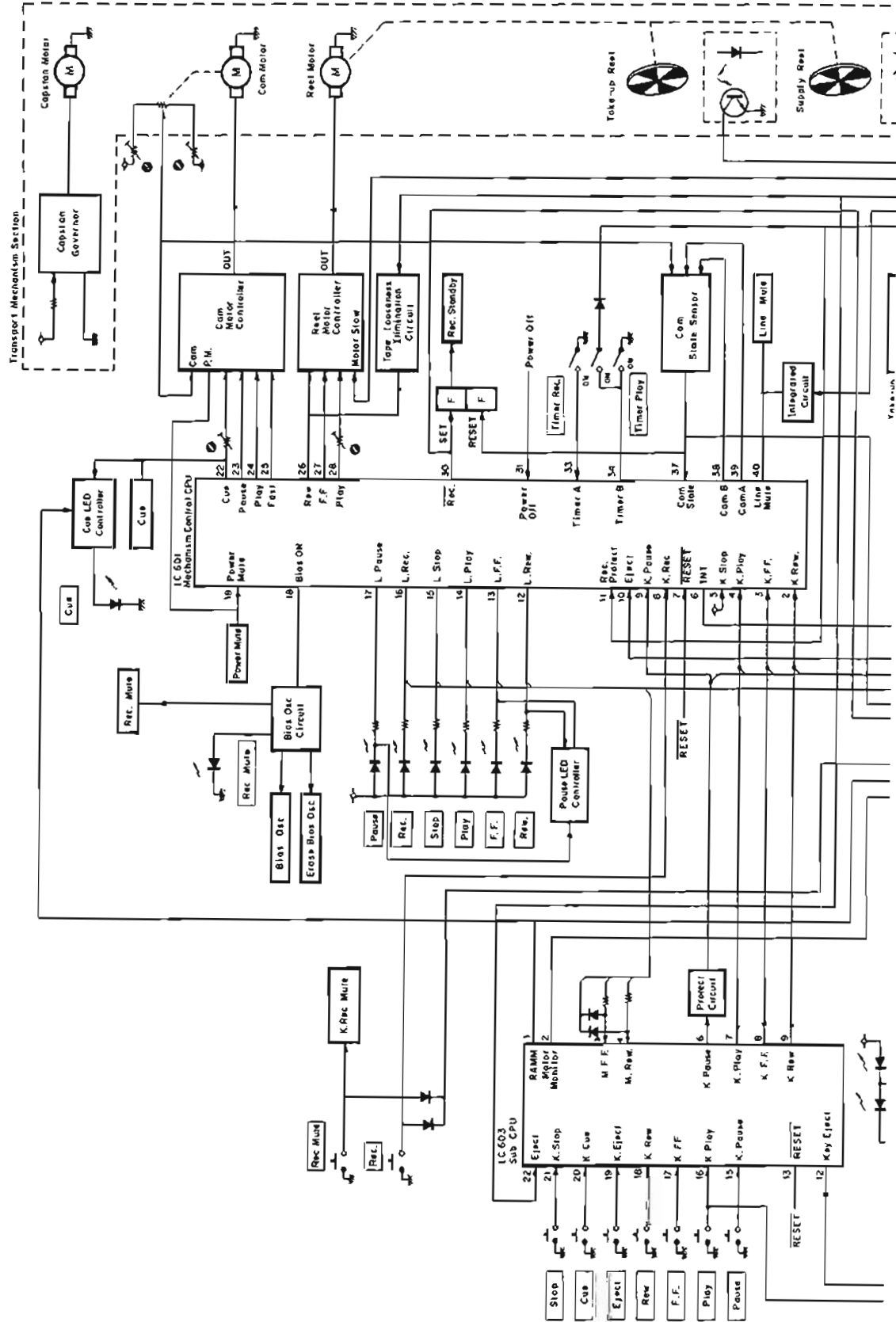

Fig. 10.2

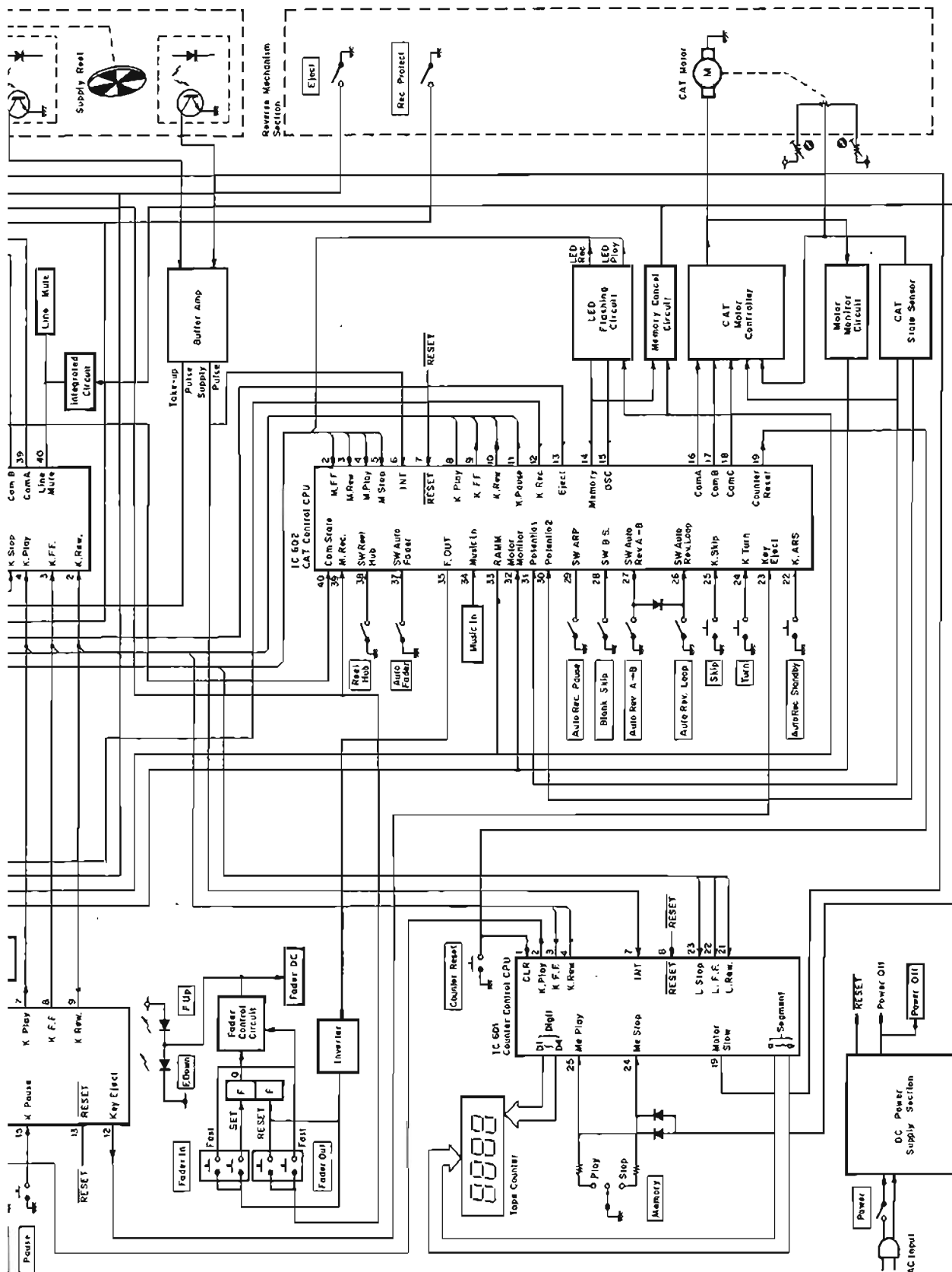

Fig. 10.2

11. SPECIFICATIONS

Track Configuration	4 Tracks/2-Channel Stereo (auto-reverse recording and playback)
Heads	3 (Erase Head x 1, Record Head x 1, Playback Head x 1)
Motors (Tape Transport)	PLL Servo Motor (Capstan Drive) x 1 DC Motor (Reel Drive) x 1
Power Source	100, 120, 120/220-240, 220 or 240 V AC; 50/60 Hz (According to country of sale)
Power Consumption	33 W max.
Tape Speed	1-7/8 ips. (4.8 cm/sec.)
Wow and Flutter	Less than 0.04% WTD RMS Less than 0.08% WTD Peak
Frequency Response	20 Hz — 20,000 Hz \pm 3 dB (recording level -20 dB)
Signal to Noise Ratio	Dolby C-Type NR on <70 μ s, ZX tape> Better than 70 dB (400 Hz, 3% THD, IHF A-WTD RMS) Dolby B-Type NR on <70 μ s, ZX tape> Better than 64 dB (400 Hz, 3% THD, IHF A-WTD RMS)
Total Harmonic Distortion	Less than 0.9% (400 Hz, 0 dB, ZX tape) Less than 1.0% (400 Hz, 0 dB, SX, EXII tape)
Erasure	Better than 60 dB (100 Hz, 0 dB)
Separation	Better than 36 dB (1 kHz, 0 dB)
Crosstalk	Better than 60 dB (1 kHz, 0 dB)
Bias Frequency	105 kHz
Input (Line)	50 mV/70 k Ω
Output (Line)	1.0 V (400 Hz, 0 dB, output level control at max.) 2.2 k Ω
(Headphones)	12 mW (400 Hz, 0 dB, output level control at max.) 8 Ω load
Fast-Winding Time	Approx. 60 seconds (with C-60 cassette)
Dimensions	450 (W) x 144 (H) x 300 (D) millimeters 17-3/4 (W) x 5-11/16 (H) x 11-13/16 (D) inches
Approximate Weight	10 kg 22 lb. 1 oz.

- Specification and appearance design are subject to change for further improvement without notice.
- Noise Reduction System manufactured under license from Dolby Laboratories Licensing Corporation.
- The word "DOLBY" and the Double-D-Symbol are trademarks of Dolby Laboratories Licensing Corporation.

Service Manual

Nakamichi RX-505, RX-505E

Nakamichi Corporation

Tokyo Office
Shinjuku Daiichi Seimei Bldg.
2-7-1 Nishishinjuku, Tokyo
Phone (03) 342-4461
Telex : 2324721 (NAKAM J)

Nakamichi U.S.A. Corporation

19701 South Vermont Avenue
Torrance, California 90502
Phone : (213) 538-8150

Nakamichi GmbH

Stephanienstrasse 6, 4000 Düsseldorf 1
Phone : (0211) 359036