

# Service Manual

Remote Control Unit

SoundSpace 10/11/12/21

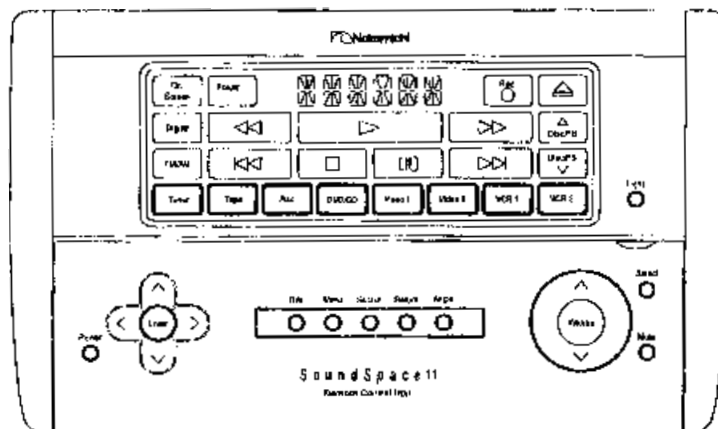

**CONTENTS**

<b>1. REMOVAL PROCEDURES</b> .....	<b>2</b>
<b>2. MECHANISM ASS'Y AND PARTS LIST</b> .....	<b>3</b>
<b>3. MOUNTING DIAGRAMS AND PARTS LIST</b> .....	<b>5</b>
3.1. Main P.C.B. Ass'y/Sensor P.C.B. Ass'y .....	5
<b>4. IC BLOCK DIAGRAMS</b> .....	<b>8</b>
<b>5. BLOCK DIAGRAM</b> .....	<b>10</b>
<b>6. WIRING DIAGRAM</b> .....	<b>11</b>
<b>7. SCHEMATIC DIAGRAM</b> .....	<b>12</b>

**1. REMOVAL PROCEDURES**

Refer to Figs. 1.1 to 1.3.

- (1) Open F01 (Battery Cover).
- (2) Remove screws F02 (4 pcs.), F03 (1 pce.) to detach F04 (Bottom Cabinet Ass'y) and F05 (Front Panel Ass'y).
- (3) Remove screws F06 (4 pcs.) to detach F07 (Main P.C.B. Ass'y) from F05 (Front Panel Ass'y).
- (4) Remove screws F08 (2 pcs.) to detach F09 (Sensor P.C.B. Ass'y) from F04 (Bottom Cabinet Ass'y).

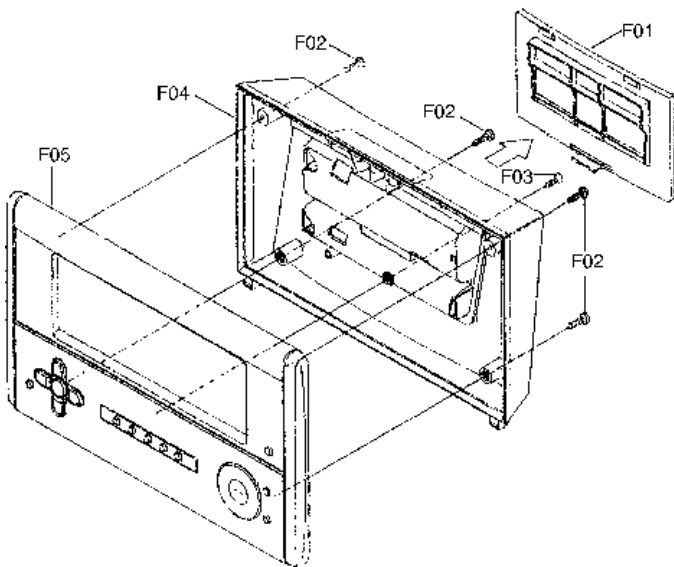

Fig. 1.1

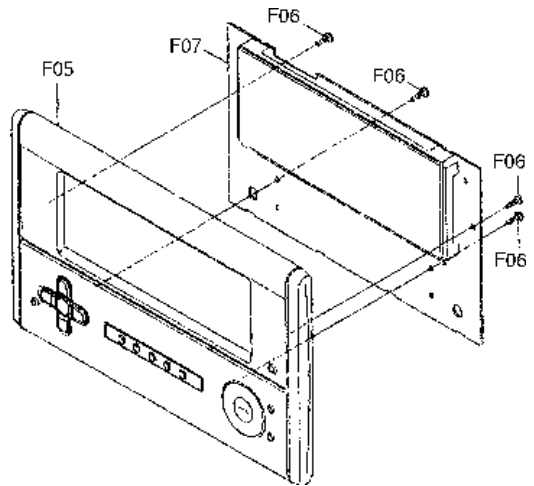

Fig. 1.2

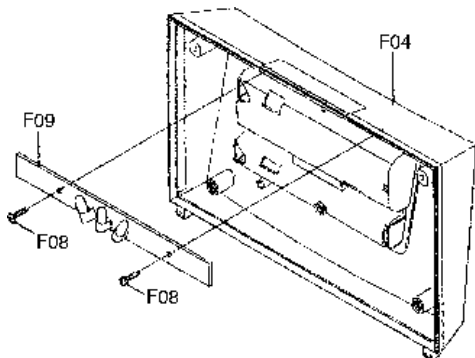

Fig. 1.3

## 2. MECHANISM ASS'Y AND PARTS LIST

### 2.1. Synthesis

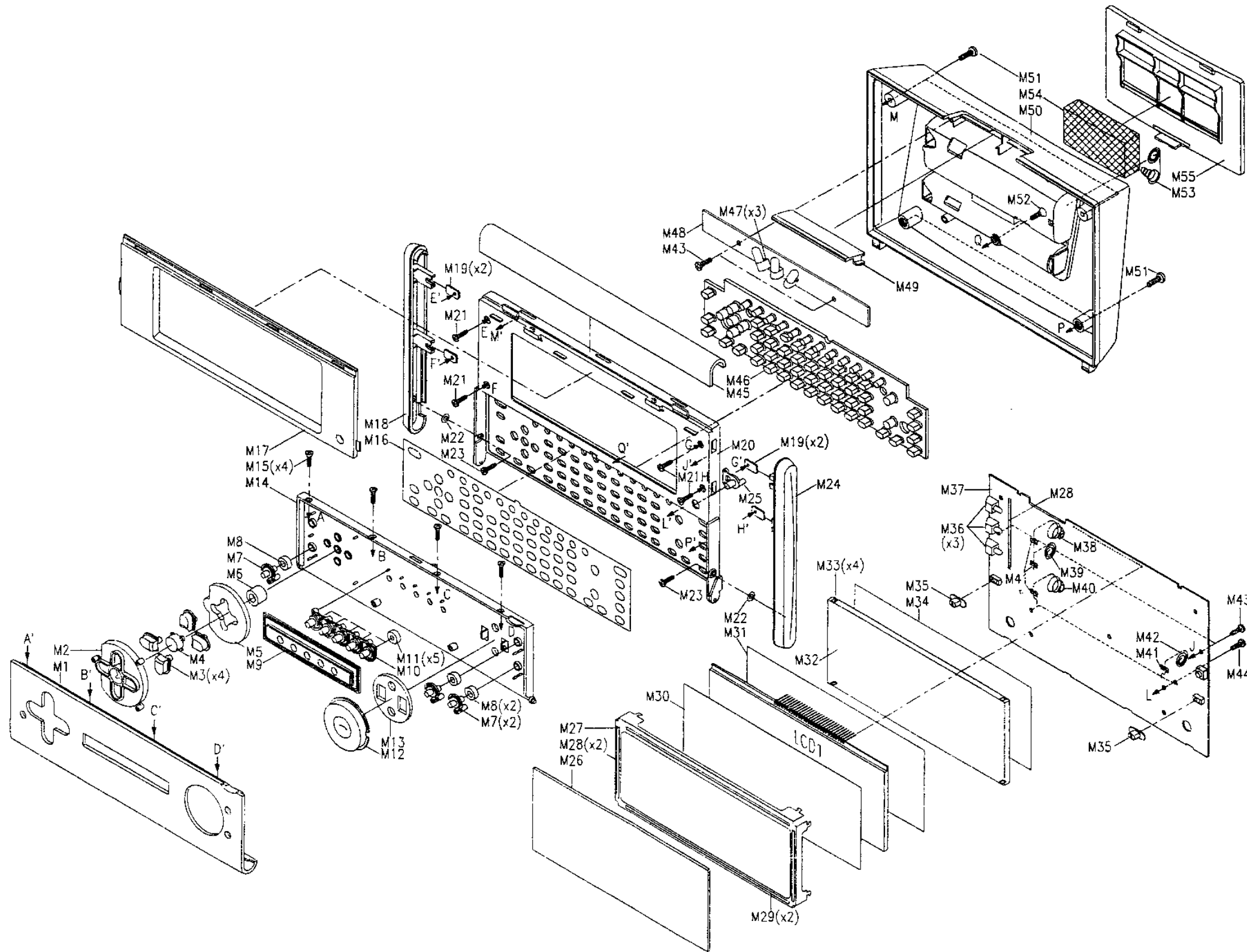

Fig. 2

## 2.1. Synthesis

Schematic Ref. No.	Part No.	Description	Q'ty
	—	<b>Synthesis</b>	
M1	2H00289A	Door SS-11	1
	2H00326A	Door SS-10	1
	2H00327A	Door SS-21	1
	2H00328A	Door SS-12	1
M2	2H00290A	Skip Button Cover	1
M3	2H00291A	Skip Button	4
M4	2H00292A	Enter Button	1
M5	2J00270A	RMC Skip Cushion	1
M6	2J00271A	RMC Enter Cushion A	1
M7	2H00293A	Push Button	3
M8	2J00272A	RMC Enter Cushion	3
M9	2H00294A	Button Cover	1
M10	2H00295A	Search Button	1
M11	2J00273A	RMC Enter Cushion B	5
M12	2H00296A	Volume Button	1
M13	2J00274A	RMC Volume Cushion	1
M14	2H00297A	Door Cover	1
M15	2E00198A	9 FLT2005 ZN3K	4
M16	2H00298A	Name Plate SS-10/11/12	1
	2H00329A	Name Plate SS-21	1
M17	2H00299A	Top Window	1
M18	2H00300A	Side Cover L SS-10/11/12	1
M18-1	0H08553C	Wooden Cover L SS-21	1
M18-2	0J08474B	RMC Side Bracket L SS-21	1
M19	2H00301A	Side Bracket	1
M20	2H00302A	Top Cabinet	4
M21	2E00199A	2 BID2008 ZN3A	4
M22	2E00200A	Fiber Washer 3.2x8x0.5	2
M23	2E00201A	7 BID2605 ZN3K	2
M24	2H00303A	Side Cover R SS-10/11/12	1
M24-1	0H08554C	Wooden Cover R SS-21	1
M24-2	0J08475B	RMC Side Bracket R SS-21	1
M25	2H00304A	Light Button	1
M26	2H00305A	Touch Panel NAS-01-1D	1
M27	2H00306A	Shield Cover	1
M28	2J00275A	Cabinet Cushion H	3
M29	2J00276A	Cabinet Cushion W	2
M30	2H00307A	Shield Plate	1
M31	2J00277A	Filter Paper	1
M32	2H00308A	Lens	1
M33	2J00278A	RMS Lens Cushion	4
M34	2H00309A	Filter Plate	1
M35	2H00310A	Slide Knob	2
M36	2H00311A	LED Housing LED-4Y	3
M37	CB00733A	Main P.C.B. Ass'y	1
M38	2J00279A	Battery Spring B	1
M39	2J00280A	Battery Spring C	1
M40	2J00281A	Battery Spring D	1
M41	2J00282A	PVC Spacer	4
M42	2J00283A	Battery Spring E	1
M43	2E00183A	7 BID2608 ZN3A	4
M44	2E00202A	7 BID2605 ZN3A	2
M45	2H00312A	Front Panel	1
M46	2J00284A	Rubber Button SS-10/11/12	1
	2J00291A	Rubber Button SS-21	1
M47	2H00313A	LED Housing LED5-4.5T	3
M48	CB00734A	Sensor P.C.B. Ass'y	1
M49	2J00285A	Sensor Plate	1
M50	2H00314A	Bottom Cabinet	1
M51	2E00203A	7 BID2610 ZN3K	4
M52	2E00204A	7 FLT2608 ZN3K	1
M53	2J00286A	Battery Spring A	1
M54	2J00287A	Battery Sponge 25x50x12t	1
M55	2H00315A	Battery Cover	1

### 3. MOUNTING DIAGRAMS AND PARTS LIST

#### 3.1. Main P.C.B. Ass'y/Sensor P.C.B. Ass'y

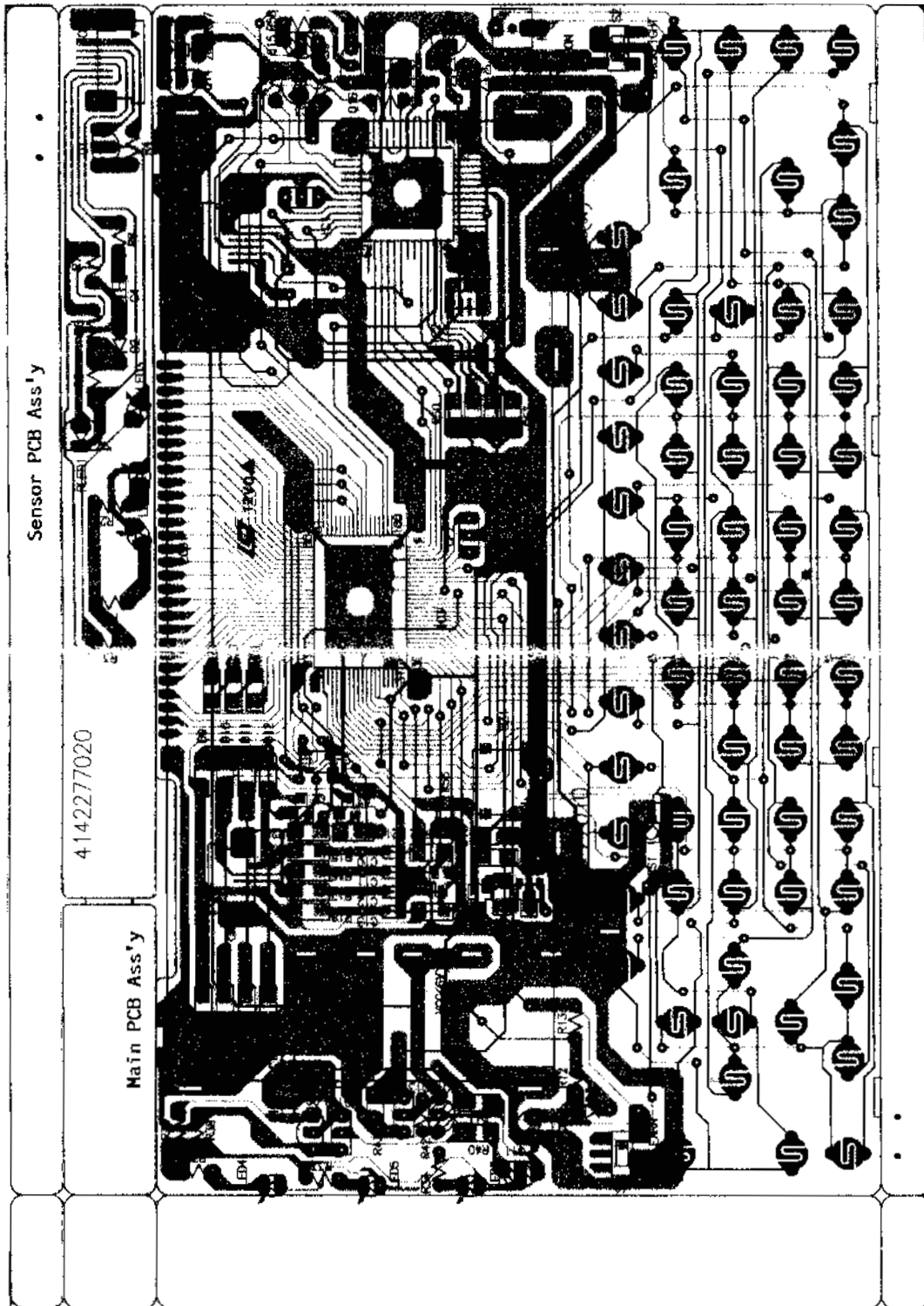

Fig. 3.1 (Component Side)

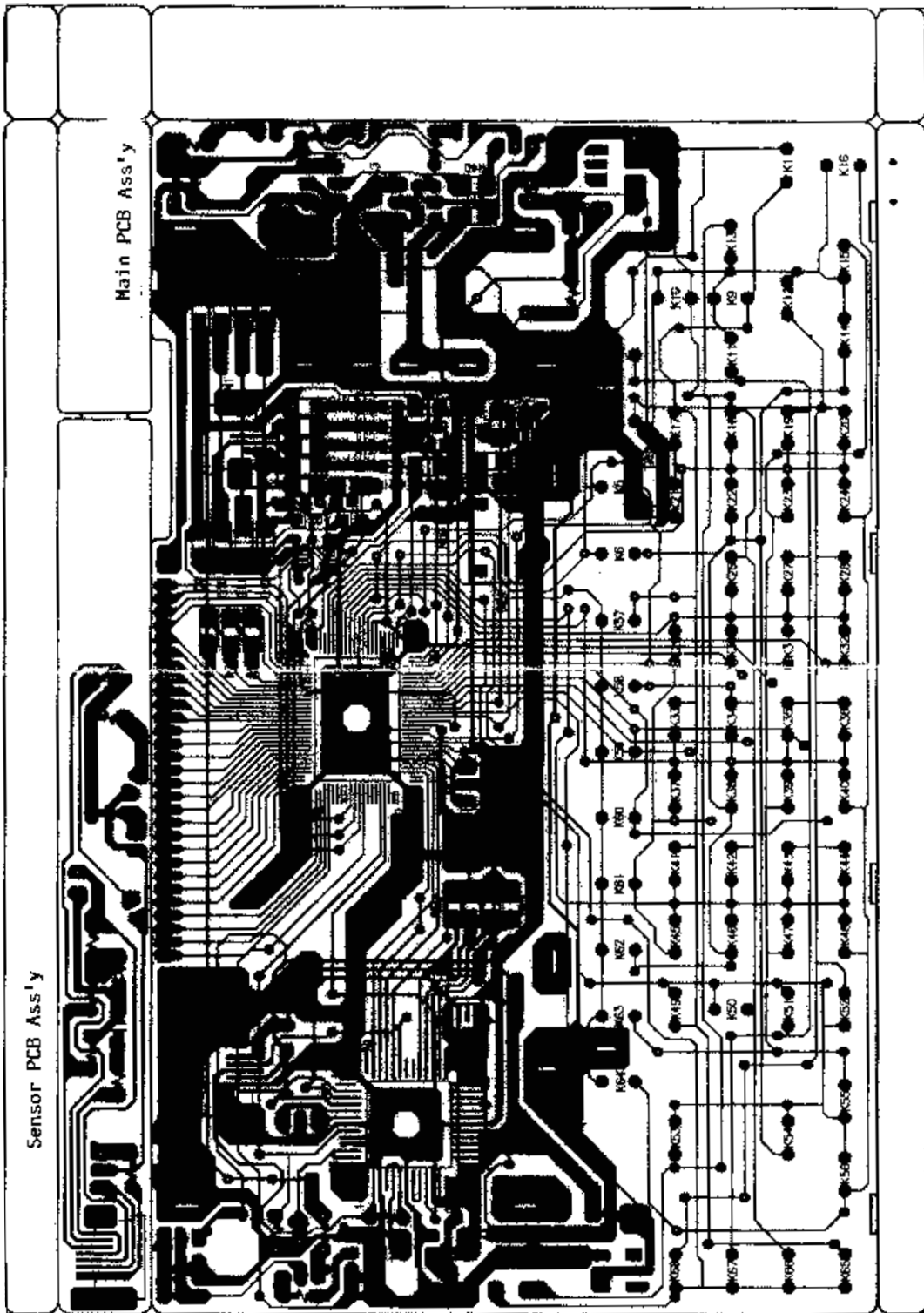

Fig. 3.2 (Dip Side)

**NOTES:** 1. Abbreviations

- TR – Transistor, SID – Silicon Diode, ZD – Zener Diode, Varicap – Variable Capacitance Diode
- RK – Carbon Resistor, RM – Metal Film Resistor, RF – Fail Safe Type Resistor,
- RC – Cement Resistor, CE – Electrolytic Capacitor, CML – Mylar Capacitor,
- CC – Ceramic Capacitor, CPP – PP Capacitor, CMM – Metalized Mylar Capacitor,
- CSP – Polystyrene Capacitor, C – Mica Capacitor, CT – Tantalum Capacitor

2. Description of capacitor: 10 16V = 10µ 16V

3. Parts marked with \* show chip parts.

● Main P.C.B. Ass'y

Schematic Ref. No.	Part No.	Description	Schematic Ref. No.	Part No.	Description
	<b>CB00733A</b>	<b>Main P.C.B. Ass'y</b>	C3	0B40176A	CE 4.7 50V M Mini
			C5	2B40045A	CML 100P 50V K
			C6	0B43144A	CC 0.1 50V J*
			C9	0B40173A	CE 1 50V M Mini
IC1	2B10304A	IC UPD17203AGC-767	C10-13	0B43064A	CC 0.01 50V J*
IC2	2B10305A	IC S-29530A	C15	0B43064A	CC 0.01 50V J*
IC3	2B10306A	IC UPD78062GF-061	C16	0B43144A	CC 0.1 50V J*
IC4	2B10307A	IC TC7W125FU	CN1	2B80216A	Base FMZ 4P Side
Q2,3	2B10308A	TR 2SA812M5*	CN2	2B80217A	Base FFC 6P Side
Q4	2B10309A	TR 2SC1623L6*			
Q5	2B10310A	TR 2SB1132Q,R E5-R*			
Q6	0B12847A	TR 2SK2158			
Q9	0B01872A	TR 2SC945P,Q			
Q10	2B10256A	TR 2SK2541 FET			
Q11,12	0B06013A	TR 2SA733P,Q			
Q13	2B10256A	TR 2SK2541 FET			
Q14	0B01872A	TR 2SC945P,Q			
Q15	0B06013A	TR 2SA733P,Q			
Q16	2B10256A	TR 2SK2541 FET			
D1	0B12249A	SID 1SS133			
D3	0B12249A	SID 1SS133			
D4	0B12745A	SID MA719			
D5-13	2B10311A	SID LL4148 GS08 EI-L			
ZD1	2B10312A	ZD RD3.9ES-AB1			
LCD1	2B90080A	LCD Display FTD-17903			
LED4-6	2B10280A	LED 3Q NSPW310BS White			
CF1,2	2B90081A	Resonator CST4.0MGW			
S1,2	2B70043A	SW Slide 00221453			
RS1	2B70044A	SW Tact SKHMPW E010 KHM903			
K69	0B70219A	SW Tact SKHVBE3520-CP			
R9	0B09700A	RK 91K 1/6W			
R10	0B09651A	RK 82K 1/6W			
R11	0B09725A	RK 100K 1/6W			
R12	0B09717A	RK 47K 1/6W			
R13,14	0B09749A	RK 1M 1/6W			
R15-18	0K20061A	RK 1K 1/6W*			
R19	0K20068A	RK 10K 1/6W*			
R20	0K20075A	RK 100K 1/4W*			
R21	0K20064A	RK 3.3K 1/4W*			
R22	2B20047A	RK 220K 1/4W*			
R29-31	0K20075A	RK 100K 1/4W*			
R32-34	0B09641A	RK 33 1/6W			
R38	0B09625A	RK 6.8 1/6W			
R39	0B09701A	RK 10K 1/6W			
R40	0K20063A	RK 2.2K 1/4W*			
R41	0K20075A	RK 100K 1/4W*			
R42	0B09693A	RK 4.7K 1/6W			
R43	0K20075A	RK 100K 1/4W*			
R50-53	0K20068A	RK 10K 1/4W*			
R54	0K20102A	RK 0 1/4W*			
R55	0K20061A	RK 1K 1/4W*			
R56	0K20075A	RK 100K 1/4W*			
R57	0B09661A	RK 220 1/6W			
R58	0B09693A	RK 4.7K 1/6W			
R59	0B09629A	RK 10 1/6W			
R60	0B09725A	RK 100K 1/6W			
C1	0B40157A	CE 4.7 6.3V M Mini			
C2	0B48040A	CE 100 10V M Mini			

● Sensor P.C.B. Ass'y

Schematic Ref. No.	Part No.	Description
	<b>CB00734A</b>	<b>Sensor P.C.B. Ass'y</b>
Q1	0B10399A	TR 2SC2001L
D2	0B12249A	SID 1SS133T-77
LED1-3	2B90082A	LED SLR-932A Infrared
RLED1	2B90083A	LED REC. PH310 Black
R1-3	0B09605A	RK 1 1/6W
R4	0B09661A	RK 220 1/6W
R5	0B09699A	RK 8.2K 1/6W
R6	0B09693A	RK 4.7K 1/6W
R7	0B09713A	RK 33K 1/6W
R8	0B09693A	RK 4.7K 1/6W
C4	2B40045A	CML 100P 50V K
CN2	2B80217A	Base FFC 6P Side

4. IC BLOCK DIAGRAMS

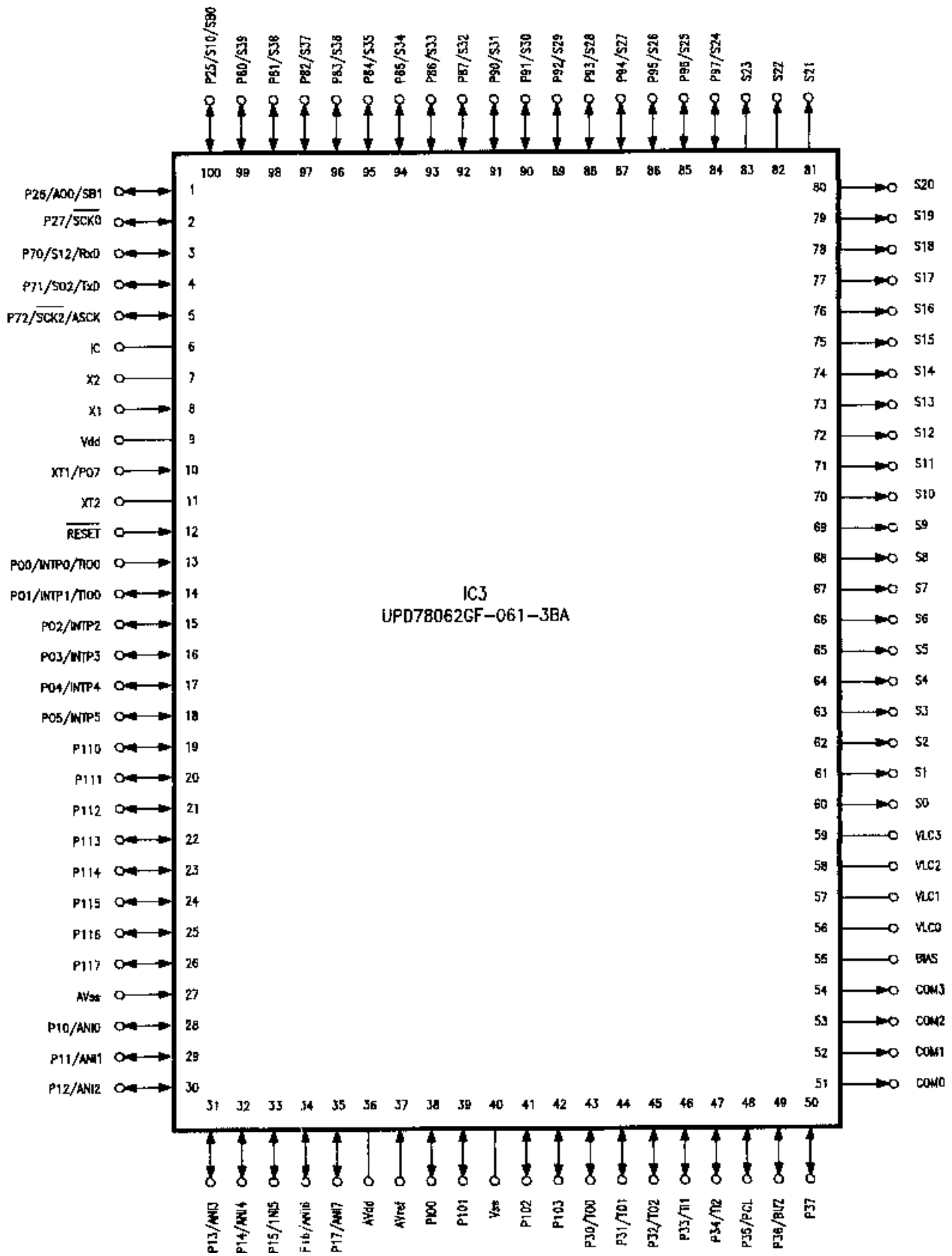

Fig. 4.1



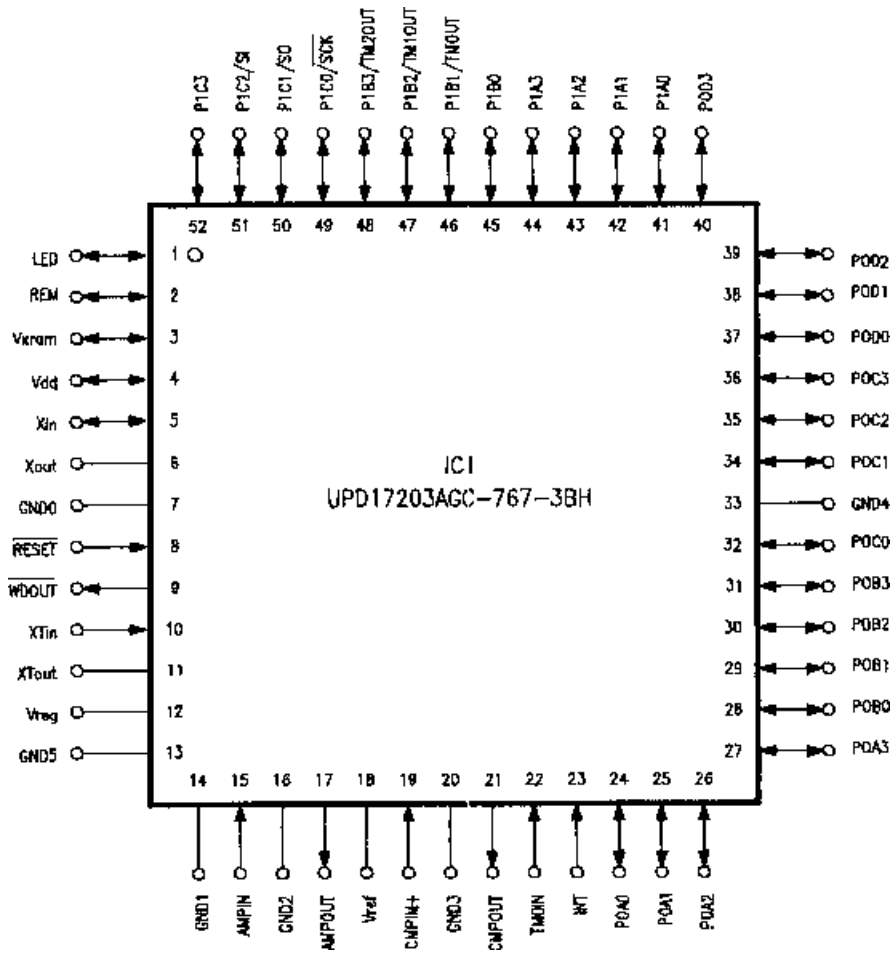

Fig. 4.2

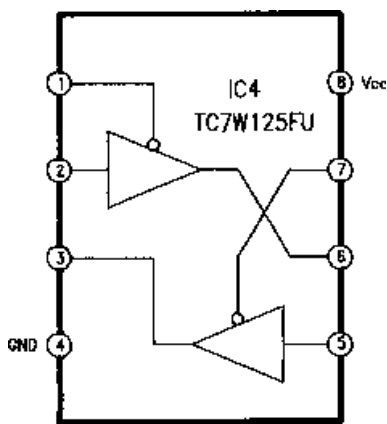

Fig. 4.3

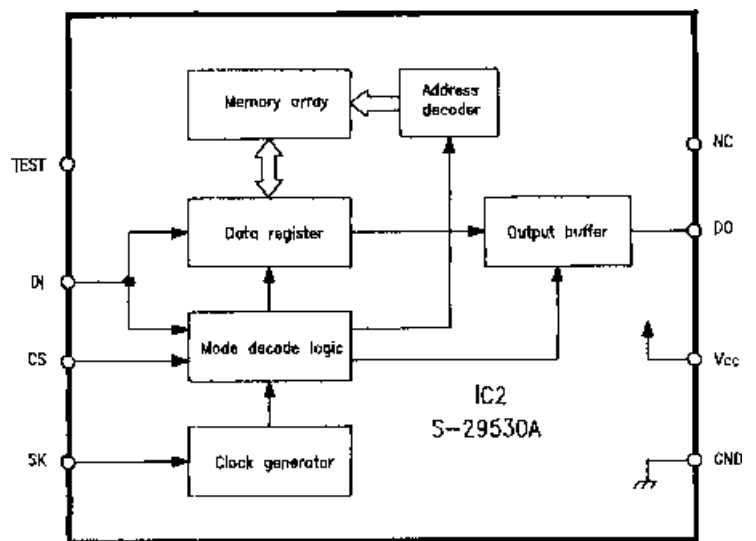

Fig. 4.4

5. BLOCK DIAGRAM

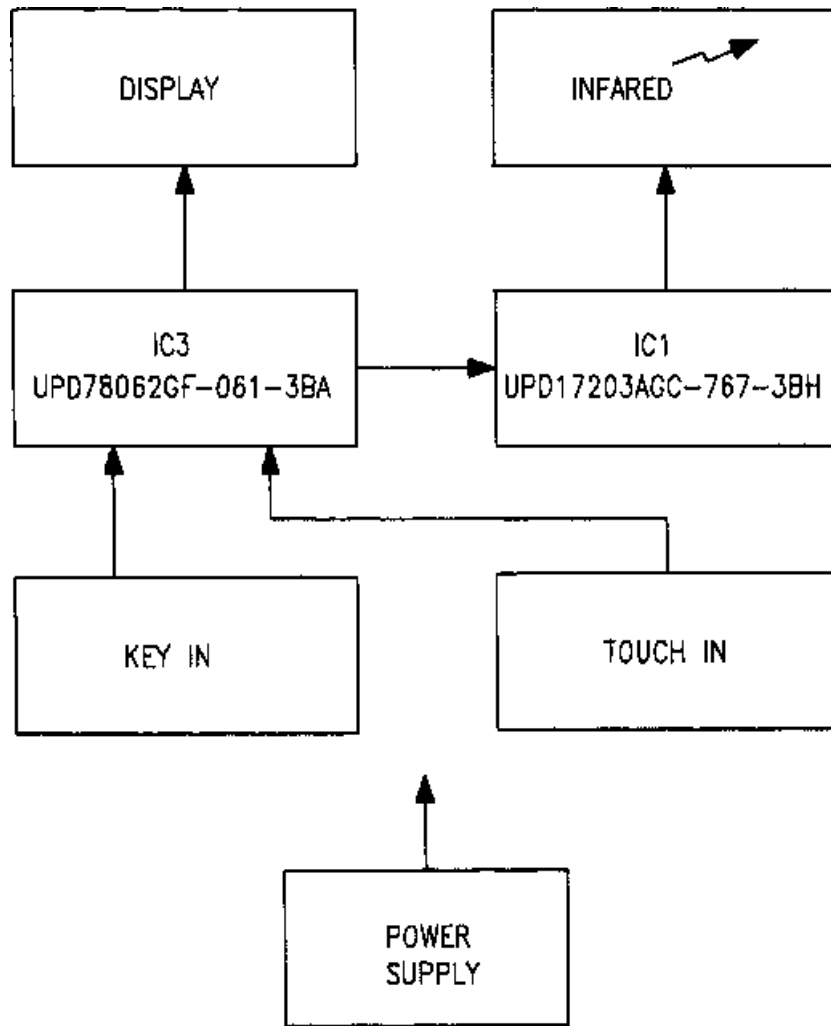

Fig. 5

6. WIRING DIAGRAM

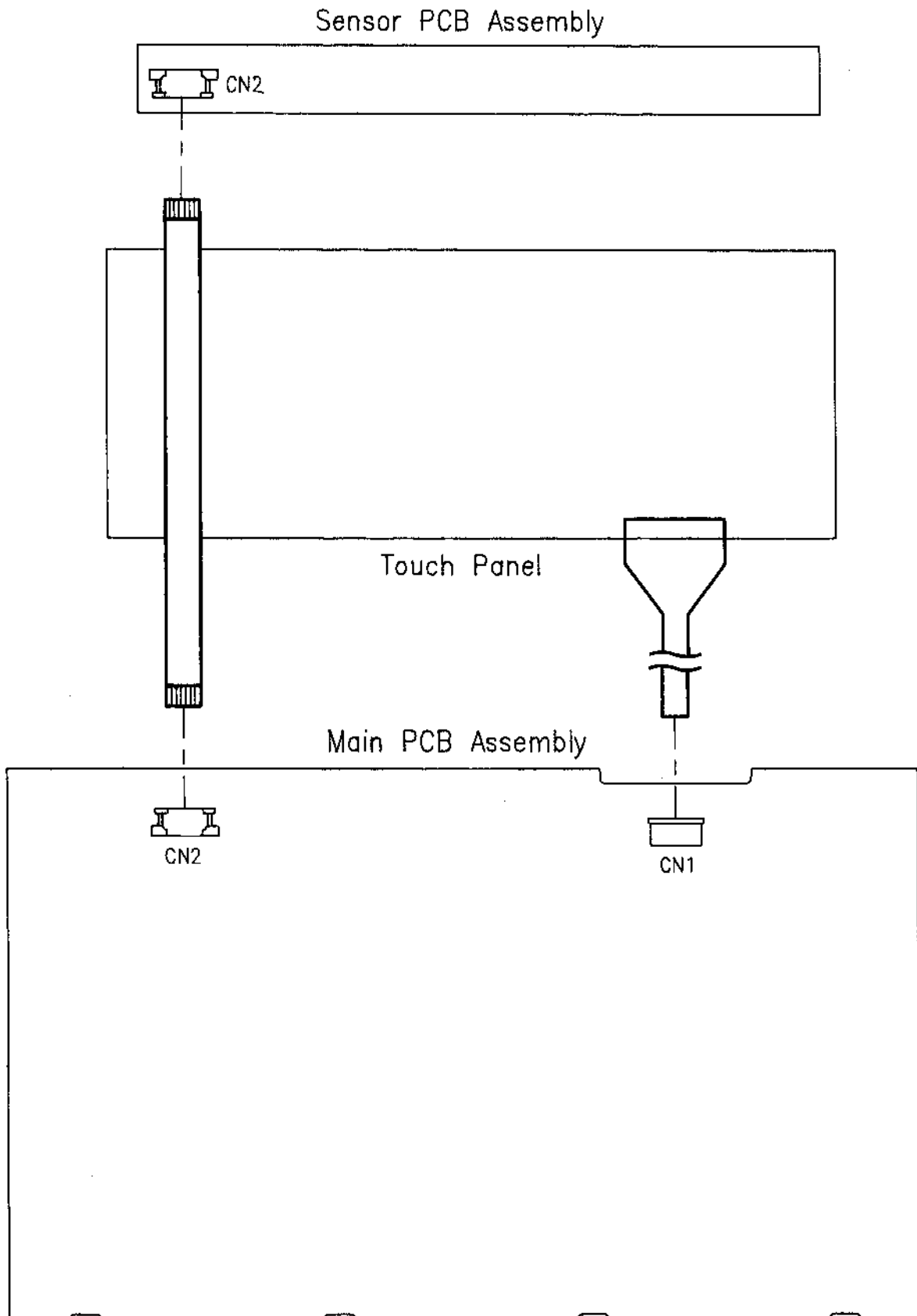

Fig. 6

7. SCHEMATIC DIAGRAM

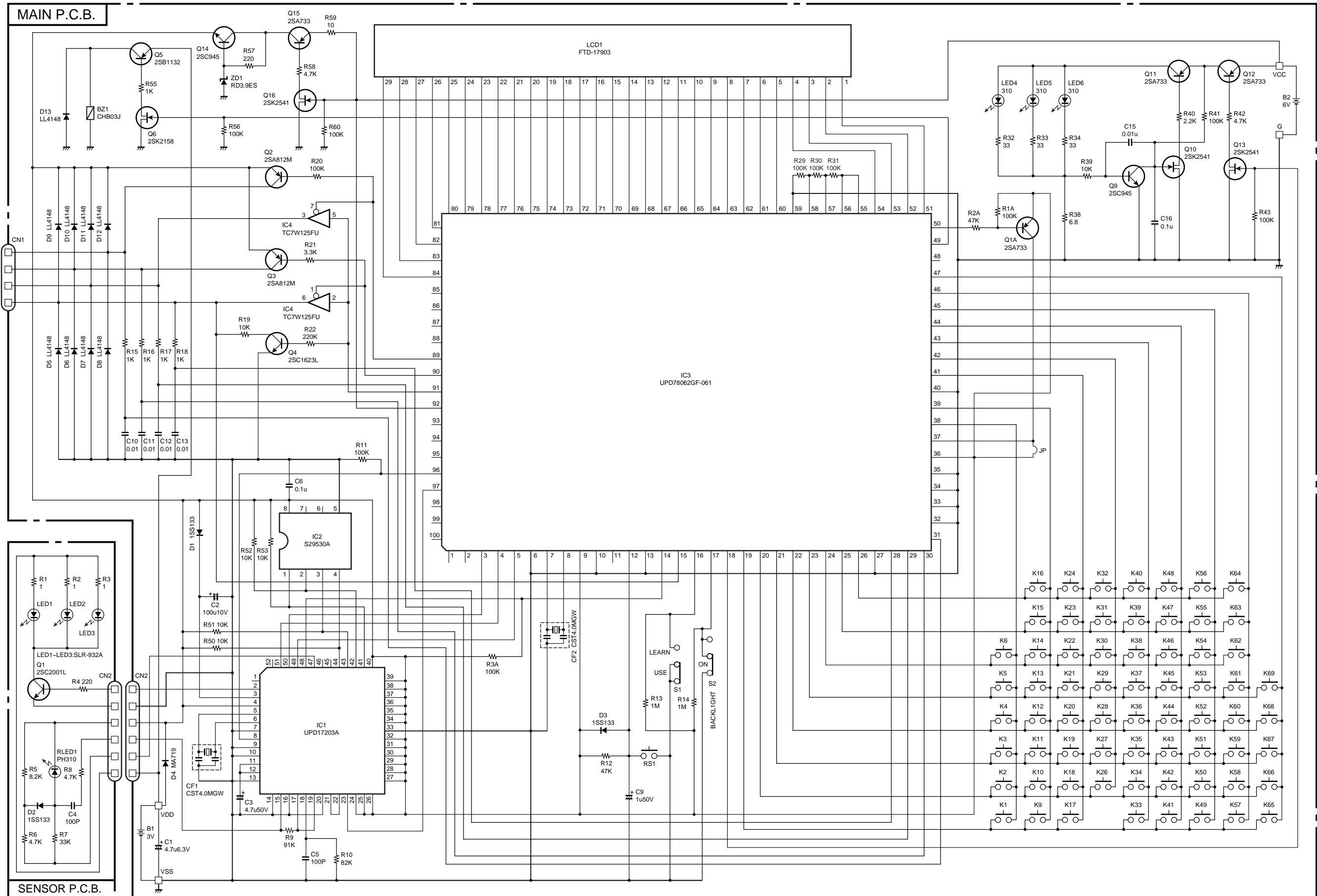

Fig. 7

Nakamichi Corporation	1-153 Suzukicho, Kodaira, Tokyo 187-8501, Japan Phone: 81 (42) 342-1111
Nakamichi America	18375 S Broadwick Street Rancho Dominguez, CA 90220 Phone: 1 (310) 631-2122 Fax: 1 (310) 631-2760
Nakamichi Asia	8/F The Grande Bldg., 398 Kwun Tong Rd., Kowloon, Hong Kong Phone: 852-2357-6690 Fax: 852 -2357-6697
Nakamichi Europe	8th Floor, Hayes Gate House, 27 Uxbridge Road Hayes, Middlesex, UB4 OJN, England Phone: 44-181-581-9191 Fax: 44-181-581-9153
Web Site	<a href="http://www.nakamichi.com">http://www.nakamichi.com</a>