



# Service Manual

# Nakamichi

TA-4

TA-4A

TA-4E

High Definition Tuner Amplifier



## CONTENTS

1.	General	1
2.	Removal Procedures	3
2. 1.	Top Cover Ass'y and Bottom Cover Ass'y	3
2. 2.	Front Panel Ass'y, Remote Control Sensor P.C.B. Ass'y and Power Indicator P.C.B. Ass'y	3
2. 3.	Front Chassis Ass'y and Control Switch & Display P.C.B. Ass'y	3
2. 4.	How to Disconnect/Connect Flat Cable	4
2. 5.	Video & Logic P.C.B. Ass'y	4
3.	Parts Location for Electrical Adjustment	5
4.	Electrical Adjustments	6
4. 1.	Power Amplifier Section	6
4. 2.	Tuner Section	6
4.2.1.	FM Tuner Section	6
4.2.2.	AM Tuner Section	8
5.	Mechanism Ass'y and Parts List	9
5. 1.	Synthesis	9
5. 2.	Front Panel Ass'y (A01)	10
5. 3.	Front Chassis Ass'y (A02)	10
5. 4.	Chassis Ass'y (A03)	11
5. 5.	Heat Sink Ass'y (B01)	13
6.	Mounting Diagrams and Parts List	14
6. 1.	Power Switch P.C.B. Ass'y	14
6. 2.	Speaker Terminal P.C.B. Ass'y	14
6. 3.	Pin Jack P.C.B. Ass'y	14
6. 4.	Headphone Jack P.C.B. Ass'y	14
6. 5.	Power Indicator P.C.B. Ass'y	14
6. 6.	Volume Indicator P.C.B. Ass'y	15
6. 7.	Volume Motor P.C.B. Ass'y	15
6. 8.	Transistor Joint P.C.B. Ass'y	15
6. 9.	Remote Control Sensor P.C.B. Ass'y	15
6. 10.	IF Band Switch P.C.B. Ass'y	15
6. 11.	Selector P.C.B. Ass'y	15
6. 12.	Remote Jack P.C.B. Ass'y	16
6. 13.	Volume P.C.B. Ass'y	16
6. 14.	Power Supply P.C.B. Ass'y	16
6. 15.	Standby P.C.B. Ass'y	17
6. 16.	Tone Control P.C.B. Ass'y	17
6. 17.	Control Switch & Display P.C.B. Ass'y	19
6. 18.	Tuner P.C.B. Ass'y	21
6. 19.	Video & Logic P.C.B. Ass'y	24
6. 20.	Main P.C.B. Ass'y	25
7.	Schematic Diagrams	27
7. 1.	IC Block Diagrams	27
7. 2.	Schematic Diagrams	30
7.2.1.	Tuner Section	30
7.2.2.	Video and Control Section	31
7.2.3.	Amplifier Section	32
8.	Wiring Diagram	33
9.	Block Diagrams	34
9. 1.	Tuner Section	34
9. 2.	Amplifier Section	35
10.	Specifications	36

## 1. GENERAL

### 1.1. CAUTIONS/WARNINGS

#### (1) Product Safety Notice

Parts marked with the symbol  in the schematic diagram have critical characteristics.

Use ONLY replacement parts recommended by the manufacturer.

It is recommended that the unit be operated from a suitable DC supply or batteries during initial check-out procedures.

#### (2) Leakage Current Check/Resistance Check

Before returning the unit to the customer, make sure you make either (1) a leakage current check or (2) a line to chassis resistance check. If the leakage current exceeds 0.5 milliamp, or if the resistance from chassis to either side of the power cord is less than 240 k ohms, the unit is defective.

**WARNING — DO NOT** return the unit to the customer until the problem is located and corrected.

**(3) Lithium Battery Caution**

Use ONLY replacement parts recommended by the manufacturer. Replacement must be done only by qualified service personnel because of risk for explosion.

**VARNING**

Litiumbatteri. Explosionsfara vid felaktig hantering. Byte får endast ske av sakkunnig personal enligt servicedokumentationens anvisningar.

**ADVARSEL!**

Lithiumbatterier. Eksplosionsfare. Udskiftning må kun foretages af en sagkyndig og som beskrevet i servicemanualen. batterierne kun må udskiftes med batterier af samme fabrikat og type.

**1.4. Package Ass'y**

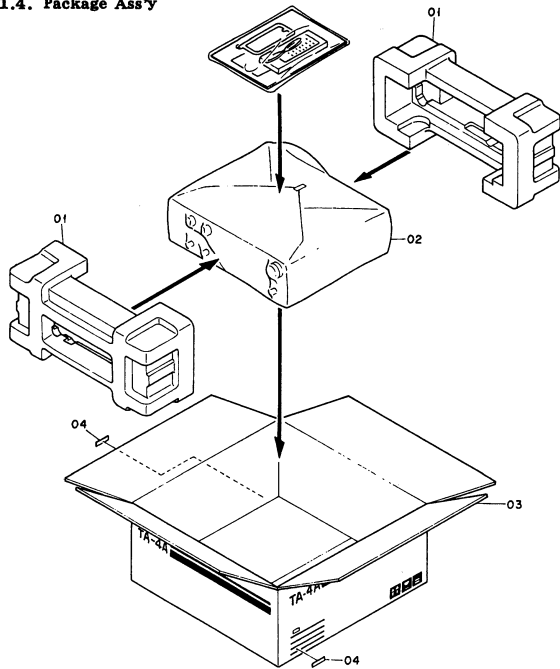

Fig. 1.1

**1.2. Destination**

- TA-4: Other
- TA-4A: U.S.A. & Canada
- TA-4E: Europe

**1.3. Voltage Selector**

Voltage selector is installed on the rear panel of the TA-4 (Other). This voltage selector can select 110, 120, 220, or 240 V at customer's disposal.

**1.5. Accessory Ass'y**

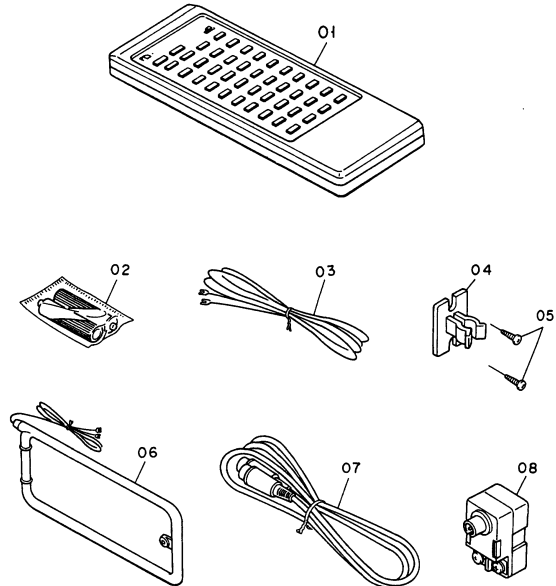

Fig. 1.2

Schematic Ref. No.	Part No.	Description	Q'ty	Schematic Ref. No.	Part No.	Description	Q'ty
		<b>Package Ass'y</b>				<b>Accessory Ass'y</b>	
01	OF04176A	Packing (TA-4/4E)	2	01	DA04183A	Remote Control Unit	1
	OF04175B	Packing (TA-4A)	2	02	OB90242A	Battery AA Type x 2 (TA-4/4E)	1
02	OF04212A	Soft Sheet (TA-4/4E)	1		OB90341A	Battery AA Type x 2 (TA-4A)	1
	OF04177A	Soft Sheet (TA-4A)	1	03	OB90320A	Feeder Antenna	1
03	OF04172A	Carton Box (TA-4)	1	04	OB90319A	AM Loop Antenna Holder	1
	OF04171A	Carton Box (TA-4A)	1	05	OE03496A	Screw 3.1x10 ♂ (For Wood)	2
	OF04174A	Carton Box (TA-4E)	1			(Black Chromate)	
04	OM05281A	Serial Number Label (TA-4/4E)	2	06	OB90318A	AM Loop Antenna	1
	OM05199A	Serial Number Label (TA-4A)	2	07	OB83465A	8P DIN Cable	1
				08	OB90194A	Antenna Adapter F YAE21-0120 (TA-4/4A)	1
					OB90208A	Antenna Adapter EP FA-322 (TA-4E)	1
				—	OD04872D	Owner's Manual (English/German/French)	1
				—	OD04836C	Warranty Card (TA-4A)	1
				—	OJ05916A	Speaker Terminal Bush (TA-4E)	8

## 2. REMOVAL PROCEDURES

### 2.1. Top Cover Ass'y and Bottom Cover Ass'y

Refer to Fig. 2.1.

- (1) Loosen screws F01 (5 pcs.) and remove F02 (Top Cover Ass'y).
- (2) Loosen screws F03 (13 pcs.) and remove F04 (Bottom Cover Ass'y).
- (3) Loosen screws F05 (2 pcs.) and remove legs F06 (2 pcs.) in order to place the unit horizontally.

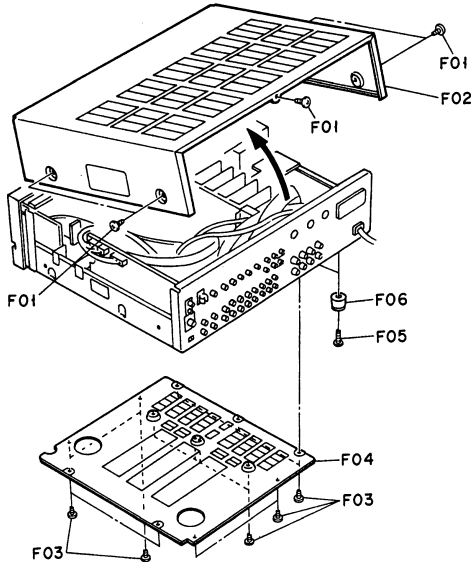

Fig. 2.1

### 2.2. Front Panel Ass'y, Remote Control Sensor P.C.B. Ass'y and Power Indicator P.C.B. Ass'y

Refer to Figs. 2.2.1 and 2.2.2.

- (1) Remove the Top Cover Ass'y and Bottom Cover Ass'y referring to item 2.1.
- (2) Loosen screws F01 (3 pcs.) and F02 (3 pcs.).
- (3) Remove F03 (Tone Volume Knob Ass'y, 2 pcs.), F04 (Selector Knob Ass'y, 2 pcs.), and F05 (Power Button).  
Note: F05 (Power Button) is hard to remove.
- (4) Turn F06 (Front Panel Ass'y) in the direction of the arrow.
- (5) Loosen a screw F07 and remove F08 (Remote Control Sensor P.C.B. Ass'y). Refer to Fig. 2.2.2.
- (6) Loosen a screw F09 and remove F10 (Power Indicator P.C.B. Ass'y).

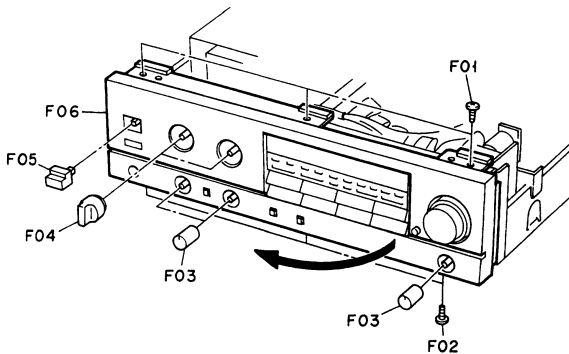

Fig. 2.2.1

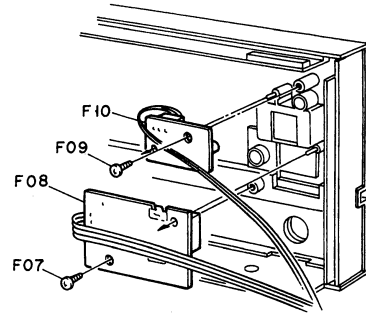

Fig. 2.2.2

### 2.3. Front Chassis Ass'y and Control Switch & Display P.C.B. Ass'y

Refer to Figs. 2.3.1 and 2.3.2.

- (1) Remove the Front Panel Ass'y referring to item 2.2.
- (2) Loosen screws F01 (4 pcs.) and remove F02 (Front Chassis Ass'y).  
Note: As the pins of F02 (Front Chassis Ass'y) are inserted into the chassis, pull F02 (Front Chassis Ass'y) toward you to separate it.
- (3) Loosen screws F03 (6 pcs.), unhook Claws (2 pcs.), and remove F04 (Control Switch & Display P.C.B. Ass'y). Refer to Fig. 2.3.2.  
Note: To disconnect flat cables of F04 (Control Switch & Display P.C.B. Ass'y) from Video & Logic P.C.B. Ass'y, refer to item 2.4.

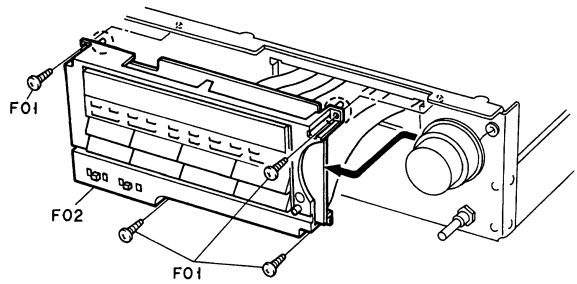

Fig. 2.3.1

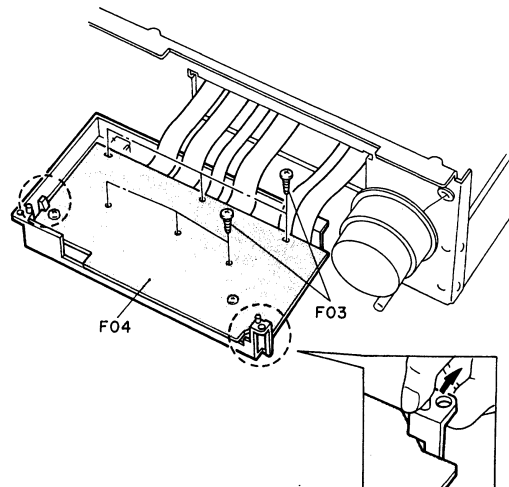

Fig. 2.3.2

#### 2.4. How to Disconnect/Connect Flat Cable

Refer to Figs. 2.4.1 and 2.4.2.

- (1) To disconnect a flat cable, press down F01 (Connector Cover) strongly and remove F02 (Flat Cable). Refer to Fig. 2.4.1.
- (2) To connect a flat cable, straighten the leads of flat cable and position each lead to the grooves of connector. Refer to Fig. 2.4.2.
- (3) Press down F01 (Connector Cover) and insert F02 (Flat Cable).

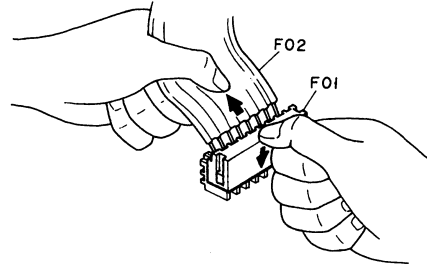

Fig. 2.4.1

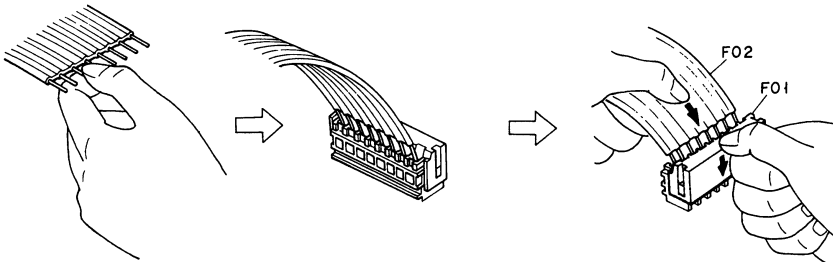

Fig. 2.4.2

#### 2.5. Video & Logic P.C.B. Ass'y

Refer to Figs. 2.5.1 and 2.5.2.

- (1) Remove the Top Cover Ass'y referring to item 2.1.
- (2) Disconnect all connectors from F04 (Video & Logic P.C.B. Ass'y). Disconnect flat cables referring to item 2.4.
- (3) Loosen screw F01 (5 pcs.) and F02 (4 pcs.).
- (4) Unhook F03 using pliers.
- (5) Turn F04 (Video & Logic P.C.B. Ass'y) as shown in Fig. 2.5.2.

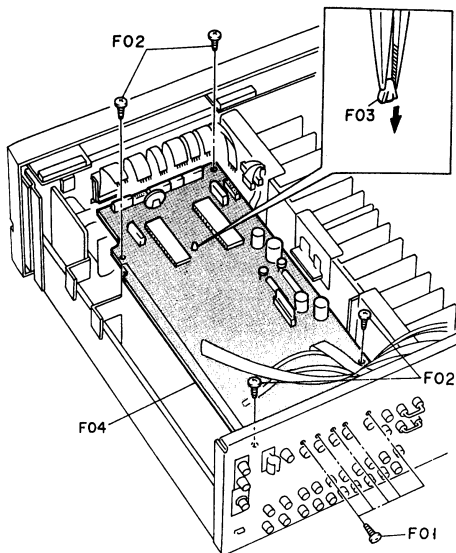

Fig. 2.5.1

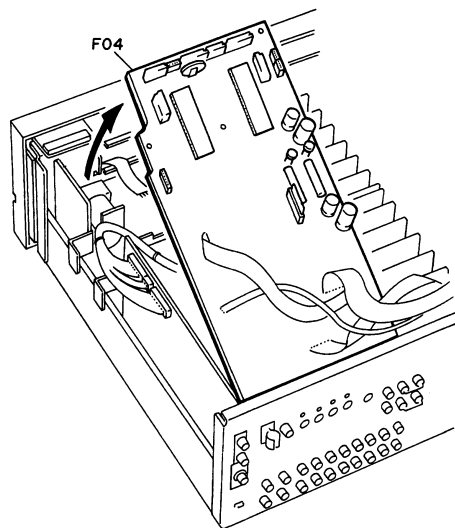

Fig. 2.5.2

### 3. PARTS LOCATION FOR ELECTRICAL ADJUSTMENT

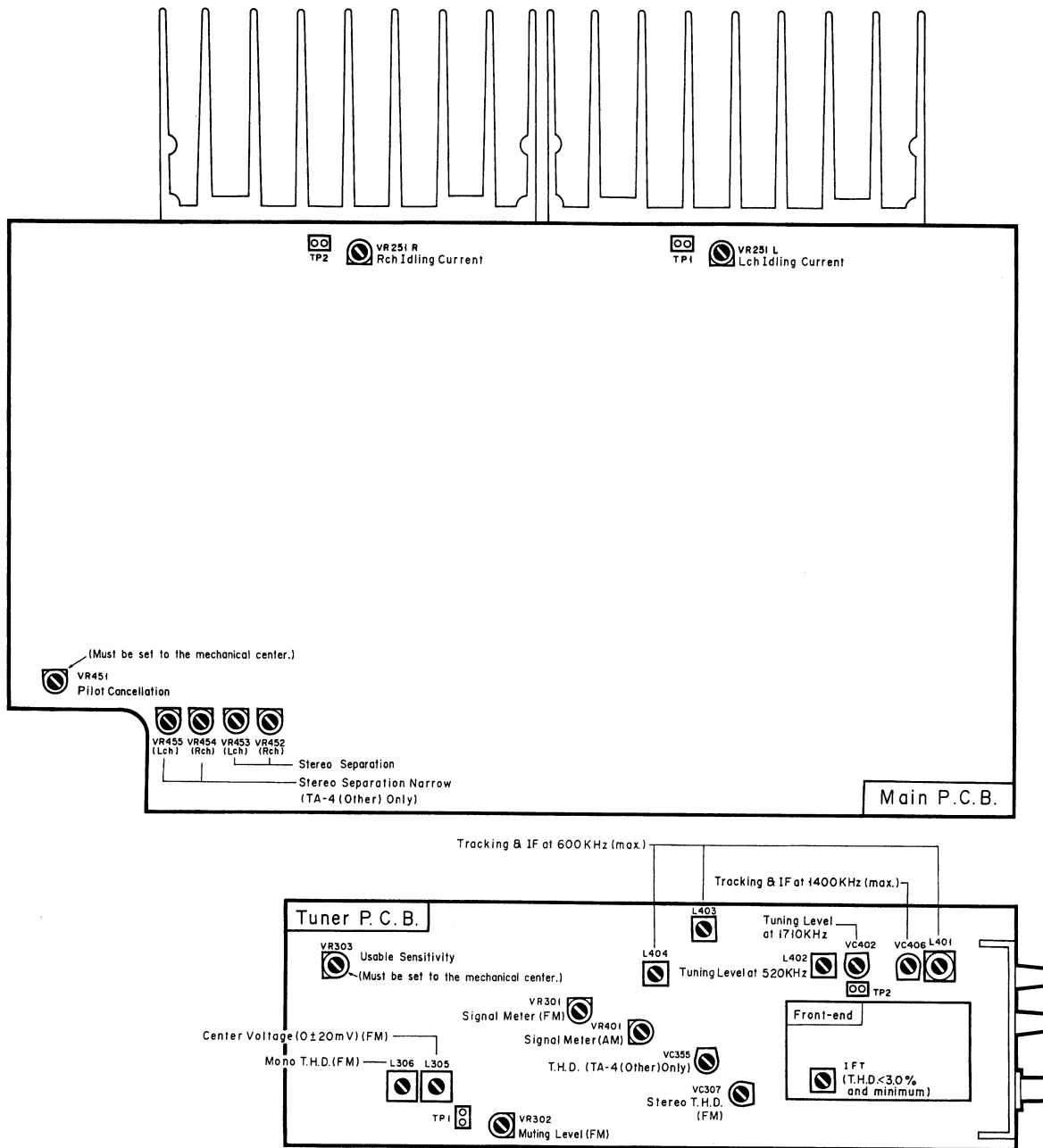

Fig. 3

#### 4. ELECTRICAL ADJUSTMENTS

##### 4.1. Power Amplifier Section

STEP	ITEM	SIGNAL SOURCE	OUTPUT CONNECTION	MODE	ADJUSTMENT	REMARKS
1	Idling Current	None	DC Voltmeter between both Pins of TP1 (Pins of TP2) on Main P.C.B.	Monitor Selector - CD Output Level - Min. Speaker Selector - OFF	Main P.C.B. VR251L VR251R	1. Insert shorting plugs into the CD Player Input Jacks. 2. Turn ON the power and allow 3 minutes before adjustment. (Top Cover must be installed in this period of time.) 3. Adjust VR251L (VR251R) to obtain 25 mV $\pm$ 5 mV on the DC voltmeter.

##### 4.2. Tuner Section

Note: Adjustment should be made in a shielded room in principle.

##### 4.2.1. FM Tuner Section

STEP	ITEM	OUTPUT CONNECTION	MODE	ADJUSTMENT	REMARKS
1	Preliminary Step	See Fig. 4.1	Tuner Amplifier Monitor Selector - Tuner Band Selector - FM Rec.Out Selector - Tuner  Signal Generator Freq. - 98 MHz RF Level - 65 dBf Modulation - See REMARKS		1. Set the Tuner Amplifier as indicated in the MODE. 2. Adjustment and confirmation should be made after tuning in to the set carrier frequency of the Signal Generator.  Note: Contents of modulation 1. For U.S.A., Canada & Other (Wide) o Stereo Audio: 1 kHz, 91% Pilot: 19 kHz, 9% o Mono Audio: 1 kHz, 100% 2. For Europe & Other (Narrow) o Stereo Audio: 1 kHz, 51% Pilot: 19 kHz, 9% o Mono Audio: 1 kHz, 60%
2	Usable Sensitivity Adjustment	Distortion Meter to Tape 1 Record Output Jacks	Tuner Amplifier Same as above  Signal Generator Freq. - 98 MHz RF Level - 13.5 dBf Modulation - Mono	Tuner P.C.B. Front-end IFT	1. Set the Tuner Amplifier to Manual mode by pressing the Tuning Mode button. 2. Adjust the IFT to obtain minimum distortion (total harmonic distortion (THD): 3% or less). 3. Set the frequency of the Signal Generator to 90 MHz/106 MHz and check that the THD is 3% or less.
3	Center Voltage and THD Adjustment	DC Voltmeter between both Pins of TP1 on Tuner P.C.B. and Distortion Meter to Tape 1 Record Output Jacks	Tuner Amplifier Same as above  Signal Generator Freq. - 98 MHz RF Level - 65 dBf Modulation - Mono	Tuner P.C.B. L305 L306	1. Set the Tuner Amplifier to Manual mode. 2. Adjust L305 so that the reading on the DC voltmeter is 0 V $\pm$ 20 mV. 3. Adjust L306 to obtain minimum distortion (THD: 0.07% or less). Repeat 2 and 3, if necessary.

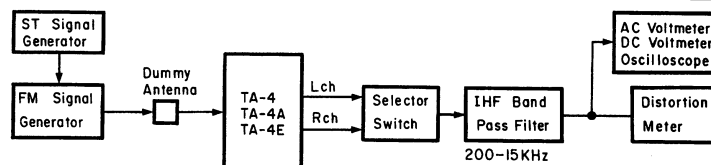

Fig. 4.1 FM Measuring Connection

STEP	ITEM	OUTPUT CONNECTION	MODE	ADJUSTMENT	REMARKS
4	Muting Level Adjustment	Oscilloscope to Tape 1 Record Output Jacks	Tuner Amplifier Same as above  Signal Generator Freq. - 98 MHz RF Level - 30 dBf Modulation - Mono	Tuner P.C.B. VR302	1. Set the Tuner Amplifier to Auto mode. 2. Rotate VR302 fully counterclockwise. Then, return it clockwise gradually until a waveform appears on the oscilloscope. 3. Decrease the RF level of the Signal Generator until the waveform on the oscilloscope disappears. Then increase the RF level gradually until a waveform appears again. At this point, check that the RF level of the Signal Generator is 30 dBf $\pm$ 6 dB.
5	Signal Strength Meter Level Adjustment	None	Tuner Amplifier Same as above  Signal Generator Freq. - 98 MHz RF Level - 56 dBf Modulation - Mono	Tuner P.C.B. VR301	1. Set the Tuner Amplifier to Auto mode. 2. Adjust VR301 so that all segments (1 - 5) of the signal strength meter light up. 3. Decrease the RF level of the Signal Generator to distinguish the segment 5. Next, increase it gradually so that the segment 5 starts illuminating. At this point, check that the RF level of the Signal Generator is 52 to 64 dBf.
6	Stereo Separation Adjustment	AC Voltmeter to Tape 1 Record Output Jacks	Tuner Amplifier Same as above  Signal Generator Freq. - 98 MHz RF Level - 65 dBf Modulation - L or R only	Main P.C.B. VR452 (Rch) VR453 (Lch)  VR454 (Rch) VR455 (Lch) (Other only)	For U.S.A., Canada & Europe versions: 1. Set the Tuner Amplifier to Auto mode. 2. Apply modulation to only L channel. 3. Adjust VR452 (Rch) to obtain minimum reading on the AC voltmeter at the R channel output jack. 4. Apply modulation to only R channel. 5. Adjust VR453 (Lch) to obtain minimum reading on the AC voltmeter at the L channel output jack.  For Other version: 1. Set the switches on the rear panel as follows: Freq. Step FM/AM - 100 kHz/10 kHz IF Band - Wide 2. Apply the same procedures as above. 3. Set the switches as follows: Freq. step FM/AM - 50 kHz/9 kHz IF Band - Narrow 4. Apply the same procedures as mentioned above. Adjust VR454 (Rch) and VR455 (Lch) instead of VR452 and VR453.
7	Stereo THD Adjustment	Distortion Meter to Tape 1 Record Output Jacks	Tuner Amplifier Same as above  Signal Generator Freq. - 98 MHz RF Level - 65 dBf Modulation - Stereo	Tuner P.C.B. VC307  VC355 (Other Only)	1. Set the Tuner Amplifier to Auto mode. 2. Apply 1 kHz (L = -R) signal. 3. Adjust VC307 to obtain minimum distortion. 4. For Other version (Narrow) only, adjust VC355 to obtain minimum distortion.



4.2.2. AM Tuner Section

Note: Frequencies for Europe & Other (Narrow) are indicated in parentheses.

STEP	ITEM	OUTPUT CONNECTION	MODE	ADJUSTMENT	REMARKS
1	Tuning Level Adjustment	DC Voltmeter between both Pins of TP2 on Tuner P.C.B.	Tuner Amplifier Monitor Selector - Tuner Band Selector - AM Rec.Out Selector - Tuner  Signal Generator Freq. - 520 (522) kHz/ 1710 (1611) kHz Modulation - 400 Hz 30%	Tuner P.C.B. L402 VC402	1. Set the frequency of the Signal Generator to 520 kHz (522 kHz) and make tuning. 2. Adjust L402 to obtain 1.4 V $\pm$ 0.02 V on the DC voltmeter. 3. Change the frequency to 1710 kHz (1611 kHz) and make tuning. 4. Adjust VC402 to obtain 22 V $\pm$ 0.2 V on on DC voltmeter. 5. Repeat 1 through 4 once.
2	Tracking and IF Adjustment	AC Voltmeter to Tape 1 Record Output Jacks	Tuner Amplifier Same as above  Signal Generator Freq. - 600 (603) kHz/ 1400 (1404) kHz RF Level - 82 dB $\mu$ Modulation - 400 Hz 30%	Tuner P.C.B. L401 L403 L404 VC406	1. Set the measurement instruments as shown in Fig. 4.2. Set the distance between the AM Loop Antenna of the TA-4/4A/4E and a test loop to 60 cm. To obtain 56 dB $\mu$ /m at the AM Loop Antenna, set the RF level output of the AM Signal Generator to 82 dB $\mu$ as loss is 26 dB in this setting. 2. Set the frequency of the Signal Generator to 600 kHz (603 kHz) and make tuning. 3. Adjust L401 to obtain maximum reading on the AC voltmeter. 4. Adjust L403 to obtain maximum reading on the AC voltmeter. 5. Adjust L404 to obtain maximum reading on the AC voltmeter. 6. Set the frequency to 1400 kHz (1404 kHz) and make tuning. 7. Adjust VC406 to obtain maximum reading on the AC voltmeter. 8. Repeat 2 through 7 once.
3	Signal Strength Meter Level Adjustment	None	Tuner Amplifier Same as above  Signal Generator Freq. - 1000 (999) kHz RF Level - 106 dB $\mu$ Modulation - 400 Hz 30%	Tuner P.C.B. VR401	1. With the same setting as in Step 2, set the RF level output of the AM Signal Generator to 106 dB $\mu$ in order to obtain 80 dB $\mu$ /m at the AM Loop Antenna. 2. Adjust VR401 so that the segment 5 of the signal strength meter starts illuminating. Note: Before adjustment, select AM mode and wait for more than three minutes.

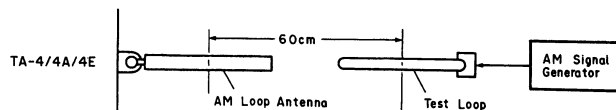

Fig. 4.2



Schematic Ref. No.	Part No.	Description	Q'ty
<b>5.1. Synthesis</b>			
		<b>Synthesis</b>	
01	OH05357A	Top Cover	1
02	OJ05626A	Bottom Cover	1
03	OH05340A	Power Button	1
04	HA05450A	Selector Knob Ass'y	2
05	HA05451A	Tone Volume Knob Ass'y	3
06	—	Front Panel Ass'y	1
07	OJ05633A	Top Cover Cushion	6
08	BA07297A	Remote Control Sensor P.C.B. Ass'y	1
09	BA07298A	Power Indicator P.C.B. Ass'y	1
10	—	Front Chassis Ass'y	1
11	BA07363A	Control Switch & Display P.C.B. Ass'y (TA-4/4E)	1
	BA07294A	Control Switch & Display P.C.B. Ass'y (TA-4A)	1
12	HA05465A	Master Volume Ass'y	1
13	BA07320A	Volume Indicator P.C.B. Ass'y	1
14	OH05356A	Volume Indicator P.C.B. Holder	1
15	HA05466A	Balance Knob Ass'y	1
16	—	Chassis Ass'y	1
17	OJ05420A	Leg N	4
18	OJ05461A	Leg Felt N	4
19	OJ05407A	Top Cover Sheet R	3
20	OB90342A	U-Shape Pin 14	2
21	OB90019A	Insu-Lock	42
22	OM05201B	Fuse Caution Label A (TA-4A)	1
23	OM05202A	Fuse Caution Label B (TA-4A)	1
24	OM04377B	Caution Label (TA-4A)	2
25	OM05148A	Production Date Label (TA-4A)	1
26	OM04113A	LA Label (TA-4 (U.S.A.))	1
27	OM04430A	Pass Label (TA-4/4E)	1
	OM05171A	Pass Label (TA-4A)	1
28	OM05281A	Serial Number Label (TA-4/4E)	1
	OM05199A	Serial Number Label (TA-4A)	1
29	OJ05706A	Side Rubber	2
L01	OE03433A	BT3x6 @ Binding Projected (Black Chromate)	11
L02	OE00857A	BT3x6 @ Binding	17
L03	OE00921A	BT3x8 @ Binding (Black Chromate)	2
L04	OE00888A	BT3x12 @ Binding	4
L05	OE00846A	BT3x8 @ Pan	6
<b>5.2. Front Panel Ass'y (A01)</b>			
A01	—	Front Panel Ass'y	1
01	OH05331A	Front Panel (TA-4)	1
	OH05329B	Front Panel (TA-4A)	1
	OH05330A	Front Panel (TA-4E)	1
02	OH05103A	LED Lens B	2
03	OH05363C	Remote Control Lens	1
04	OJ05636A	Diffuser Sheet C	1
05	OH05334A	Front Escutcheon L	1
06	OJ05750A	Push Knob Spring	1
07	OH05341A	Push Button	1
08	OH05333A	Front Escutcheon R	1
<b>5.3. Front Chassis Ass'y (A02)</b>			
A02	—	Front Chassis Ass'y	1
01	HA05478A	Video-2 Button Ass'y	1
02	HA05479A	Tape-1 Button Ass'y	1
03	HA05480A	Tape-2 Button Ass'y	1
04	HA05481A	Tape-3 Button Ass'y	1
05	HA05490A	Phono Button Ass'y	1
06	HA05491A	CD Button Ass'y	1
07	HA05492A	Tuner Button Ass'y	1
08	HA05477A	Video-1 Button Ass'y	1
09	OH05346B	Function Plate	1
10	OH05343A	Preset Lens A	11
11	OH05335A	Front Mold	1
12	OJ05633A	Top Cover Cushion	1
13	OH05344A	Display Lens	1
14	OH05338A	Preset Knob A	12
15	OH05339A	Preset Knob B	4
16	OJ05750A	Push Spring	2
17	OH05341A	Push Button	2
18	OH05342A	Muting Knob	1

**5.2. Front Panel Ass'y (A01)**

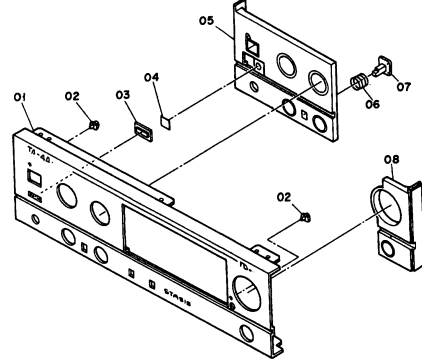

Fig. 5.2

**5.3. Front Chassis Ass'y (A02)**

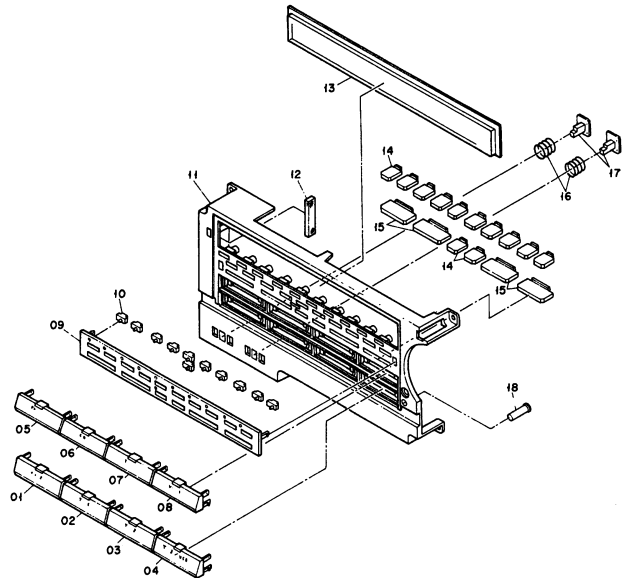

Fig. 5.3

5.4. Chassis Ass'y (A03)

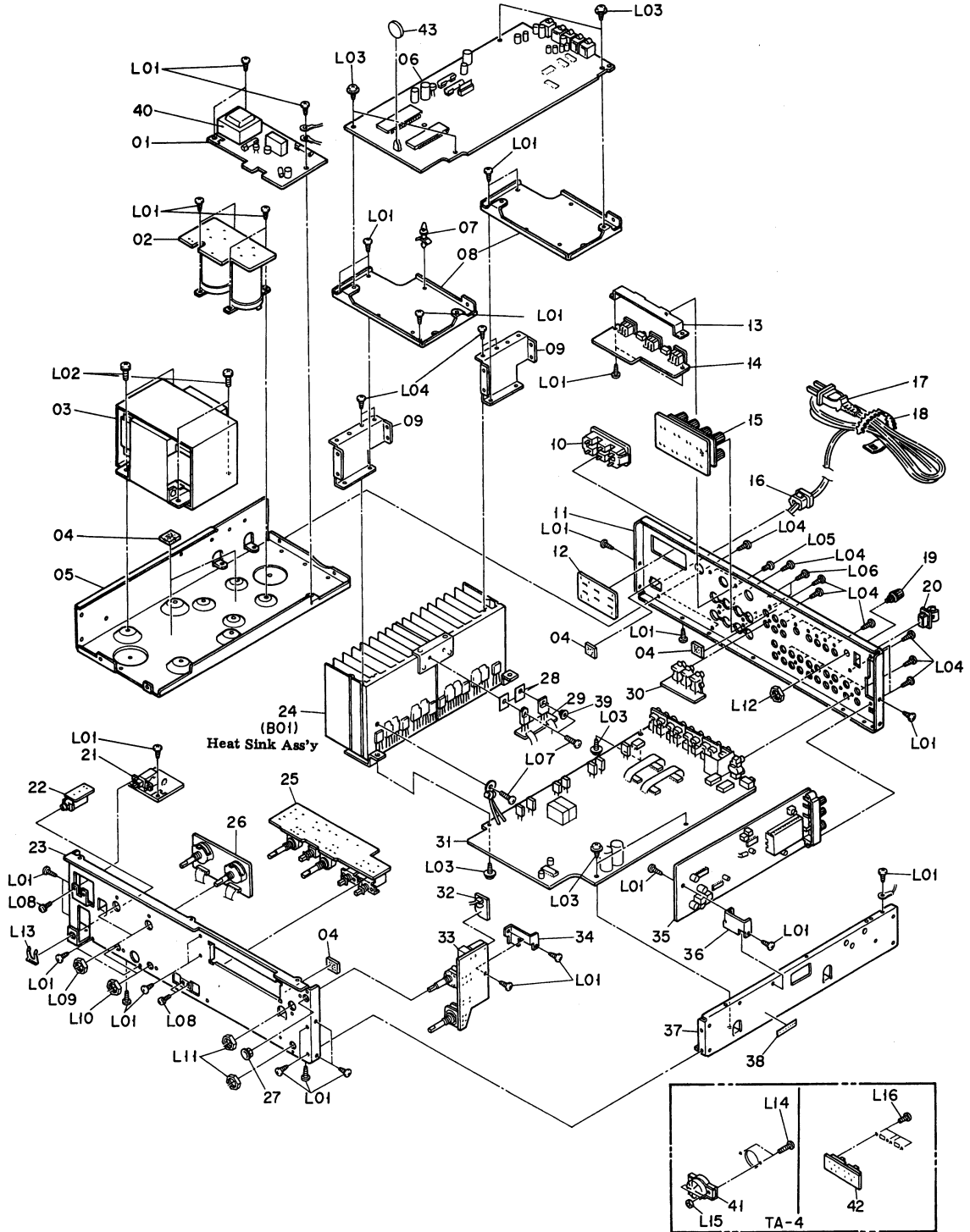

Fig. 5.4

Schematic Ref. No.	Part No.	Description	Q'ty	Schematic Ref. No.	Part No.	Description	Q'ty
<b>5.4. Chassis Ass'y (A03)</b>				L07	OE03138A	M3x10 @ Binding	3
A03	—	Chassis Ass'y	1	L08	OE00510A	M3x8 @ Pan (2A)	4
01	BA07364A	Standby P.C.B. Ass'y (TA-4)	1	L09	—	Nut	2
	BA07287A	Standby P.C.B. Ass'y (TA-4A)	1	L10	—	Nut	2
	BA07365A	Standby P.C.B. Ass'y (TA-4E)	1	L11	—	Nut	2
02	BA07284A	Power Supply P.C.B. Ass'y	1	L12	OJ05673A	Nut 70	1
03	OB50118A	Power Transformer 110V—240V (TA-4)	1	L13	OJ05427A	Mounting Plate	1
	OB50117A	Power Transformer (TA-4A)	1	L14	OE00986A	M3x10 @ Binding (TA-4)	2
	OB50119A	Power Transformer 220V—240V (TA-4E)	1	L15	OE03176A	Nut Hex, M3 (TA-4)	2
04	OJ05307A	BS Damper	5	L16	OE03202A	M2.6x3 @ Binding (Black Chromate) (TA-4)	4
05	OJ05617B	Power Supply Chassis	1	—	OE00174A	Earth Lug B-4 (TA-4E)	1
06	BA07360A	Video & Logic P.C.B. Ass'y (TA-4)	1				
	BA07296A	Video & Logic P.C.B. Ass'y (TA-4A)	1				
	BA07361A	Video & Logic P.C.B. Ass'y (TA-4E)	1				
07	OJ05637A	P.C.B. Spacer	1				
08	OJ05620B	Shield Plate	2				
09	OJ05622B	Heat Sink Holder A	2				
10	OB81706A	AC Outlet 3P (TA-4/4A)	1				
	OB81987A	AC Outlet S-16536 (TA-4E)	1				
11	OH05361A	Rear Panel (TA-4)	1				
	OH05358A	Rear Panel (TA-4A)	1				
	OH05359B	Rear Panel (TA-4E)	1				
12	OB60602A	AC Outlet P.C.B. (TA-4/4A)	1				
13	OJ05621A	DIN Jack Holder	1				
14	BA07323A	Remote Jack P.C.B. Ass'y	1				
15	BA07285A	Speaker Terminal P.C.B. Ass'y (TA-4/4A)	1				
	BA07555A	Speaker Terminal P.C.B. Ass'y (TA-4E)	1				
16	OB90280A	Cord Bushing (TA-4/4A)	1				
	OB90367A	Cord Bushing (TA-4E)	1				
17	OB80199A	AC Power Cord SPT-2 (TA-4/4A)	1				
	OB80124A	AC Power Cord (TA-4E)	1				
18	OJ05665A	Free-up Belt	1				
19	JA04383A	GND Terminal Ass'y	1				
20	OB90316A	AM Antenna Holder	1				
21	BA07283A	Power Switch P.C.B. Ass'y (TA-4/4A)	1				
	BA07553A	Power Switch P.C.B. Ass'y (TA-4E)	1				
22	BA07291A	Headphone Jack P.C.B. Ass'y	1				
23	OJ05619B	Front Chassis	1				
24	—	Heat Sink Ass'y	1				
25	BA07288A	Tone Control P.C.B. Ass'y (TA-4/4A)	1				
	BA07554A	Tone Control P.C.B. Ass'y (TA-4E)	1				
26	BA07286A	Selector P.C.B. Ass'y	1				
27	OJ05702A	Snap Bushing	1				
28	OJ05692A	Transistor Silicon Rubber B	2				
29	BA07331A	Transistor Joint P.C.B. Ass'y	1				
30	BA07290A	Pin Jack P.C.B. Ass'y	1				
31	BA07540A	Main P.C.B. Ass'y (TA-4)	1				
	BA07282A	Main P.C.B. Ass'y (TA-4A)	1				
	BA07541A	Main P.C.B. Ass'y (TA-4E)	1				
32	BA07289A	Volume Motor P.C.B. Ass'y	1				
33	BA07293A	Volume P.C.B. Ass'y	1				
34	OJ05632B	Volume Holder	1				
35	BA07357A	Tuner P.C.B. Ass'y (TA-4)	1				
	BA07295A	Tuner P.C.B. Ass'y (TA-4A)	1				
	BA07358A	Tuner P.C.B. Ass'y (TA-4E)	1				
36	OJ05631A	Tuner P.C.B. Holder	1				
37	OJ05618B	Side Chassis	1				
38	OM05210A	Amp. No. Seal (TA-4A)	1				
39	OB90369A	Transistor Bushing	1				
40	OB50115A	Sub Transformer 100V—240V (TA-4)	1				
	OB50114A	Sub Transformer (TA-4A)	1				
	OB50116A	Sub Transformer (TA-4E)	1				
41	OB70080A	Voltage Selector (TA-4)	1				
42	BA07543A	IF Band Switch P.C.B. Ass'y (TA-4)	1				
43	OB90241A	Lithium Battery	1				
L01	OE00857A	BT3x6 @ Binding	34				
L02	OE03494A	M5x10 @ Pan (2A)	4				
L03	OE03432A	BT3x6 @ Tapping (Black Chromate)	8				
L04	OE00921A	BT3x8 @ Binding (Black Chromate)	26				
L05	OE00818A	M3x8 @ Binding (Black Chromate)	2				
L06	OE03433A	BT3x6 @ Pan Projected (Black Chromate)	2				

5.5. Heat Sink Ass'y (B01)

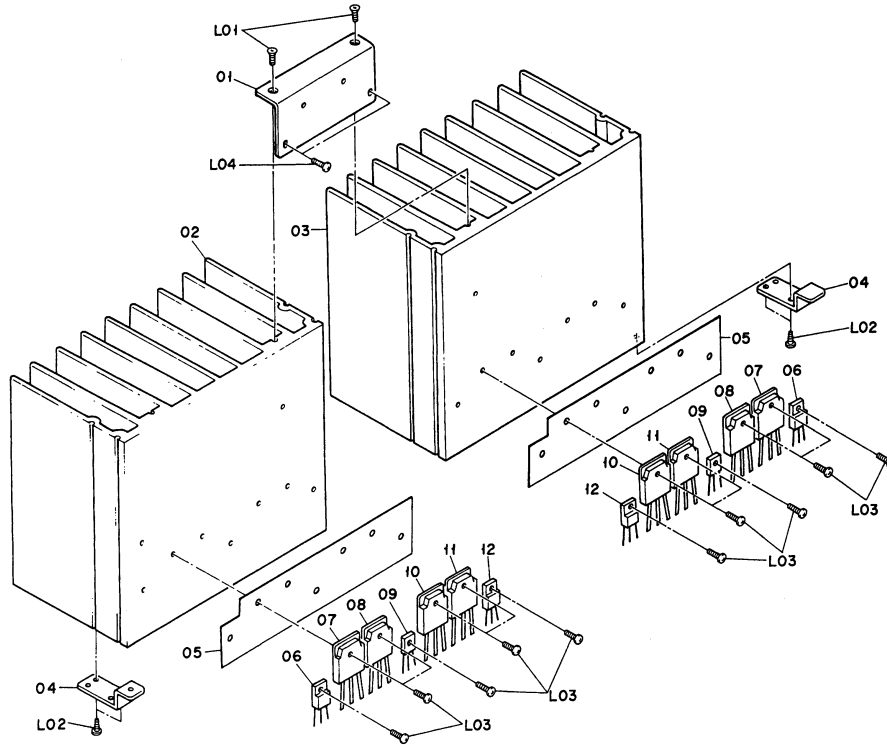

Fig. 5.5

Schematic Ref. No.	Part No.	Description	Qty
<b>5.5. Heat Sink Ass'y (B01)</b>			
<b>B01</b>	—	<b>Heat Sink Ass'y</b>	<b>1</b>
O1	OJ05630A	Joint Holder	1
O2	OJ05616A	Heat Sink	1
O3	OJ05627A	Heat Sink R	1
O4	OJ05623A	Heat Sink Holder B	2
O5	OJ05700A	Transistor Silicon Rubber	2
O6	OB10258A	Transistor 2SA1667 (O,Y) (Pair) [Q260L,R]	2
O7	OB10250A	Transistor 2SC3856 (O,Y) (Pair) [Q264L,R]	2
O8	OB10250A	Transistor 2SC3856 (O,Y) (Pair) [Q263L,R]	2
O9	OB06316A	Transistor 2SD882 (R,S) (Pair) [Q258L,R]	2
O10	OB10251A	Transistor 2SA1492 (O,Y) (Pair) [Q262L,R]	2
O11	OB10251A	Transistor 2SA1492 (O,Y) (Pair) [Q261L,R]	2
O12	OB10259A	Transistor 2SC4381 (O,Y) (Pair) [Q259L,R]	2
L01	OE03495A	BT3x10 @ Countersunk (Black Chromate)	2
L02	OE00921A	BT3x8 @ Binding (Black Chromate)	4
L03	OE03138A	M3x10 @ Binding	14
L04	OE00818A	M3x8 @ Binding	2
—	OB19011A	Thermistor [TH250]	1

6. MOUNTING DIAGRAMS AND PARTS LIST

- Notes: 1. Mounting diagram shows a dip side view of the printed circuit board.  
 2. Diode is 1SS53, 1S1555, or 1SS176 unless otherwise specified.  
 3. Following transistors are interchangeable with each other.  
 a. 2SA733, 2SA608SP, 2SA1048, 2SA1175  
 b. 2SC945, 2SC536SP, 2SC2458, 2SC2785  
 4. Abbreviation for part name:  
 TR – Transistor, SiD – Silicon Diode, ZD – Zener Diode, Varicap – Variable Capacitance Diode  
 RK – Carbon Resistor, RM – Metal Film Resistor, RF – Fail Safe Type Resistor  
 CE – Electrolytic Capacitor, CML – Mylar Capacitor, CC – Ceramic Capacitor, CPP – PP Capacitor,  
 CMM – Metalized Mylar Capacitor, CSP – Polystyrene Capacitor, C – Mica Capacitor

6.1. Power Switch P.C.B. Ass'y

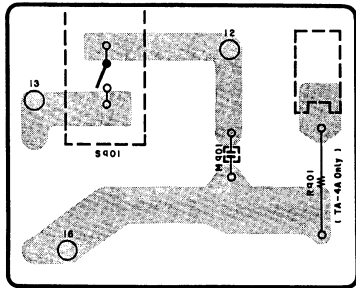

Fig. 6.1

6.2. Speaker Terminal P.C.B. Ass'y

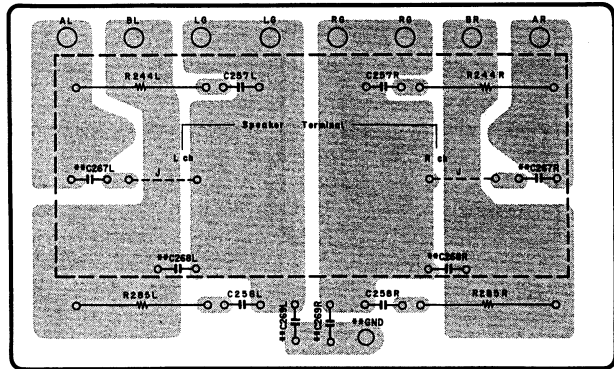

Fig. 6.2

6.3. Pin Jack P.C.B. Ass'y

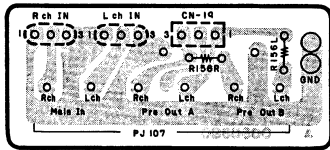

Fig. 6.3

6.4. Headphone Jack P.C.B. Ass'y

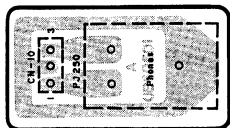

Fig. 6.4

6.5. Power Indicator P.C.B. Ass'y

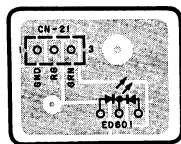

Fig. 6.5

Schematic Ref. No.	Part No.	Description	Schematic Ref. No.	Part No.	Description
6.1. Power Switch P.C.B. Ass'y			6.3. Pin Jack P.C.B. Ass'y		
	BA07283A	Power Switch P.C.B. Ass'y (TA-4/4A)		BA07290A	Pin Jack P.C.B. Ass'y
	BA07553A	Power Switch P.C.B. Ass'y (TA-4E)		OB60600A	Pin Jack P.C.B.
R901	OB60593A	Power Switch P.C.B. RK 4.7M 1/2W J (TA-4A)	R156L,R	OB09653A	RK 100 1/6W J
S901	OB71008A	Power Switch SDDLA1007U	PJ107	OB81949A	6P Pin Jack
M901	OB41829A	CC 4700P	CN19	OB81968A	3P-T Post
	OJ05670A	Earth Plate (TA-4/4A) (1)			EH-3PREDB3B
6.2. Speaker Terminal P.C.B. Ass'y			6.4. Headphone Jack P.C.B. Ass'y		
	BA07285A	Speaker Terminal P.C.B. Ass'y (TA-4/4A)		BA07291A	Headphone Jack P.C.B. Ass'y
	BA07555A	Speaker Terminal P.C.B. Ass'y (TA-4E)		OB60601A	Headphone Jack P.C.B.
R244L,R	OB60595A	Speaker Terminal P.C.B.	PJ250	OB81757A	Headphone Jack
R285L,R	OB24199A	RF 22 1W J	CN10	OB83406B	3P Connector 350mm
R257L,R	OB24199A	RF 22 1W J	6.5. Power Indicator P.C.B. Ass'y		
C257L,R	OB01609A	CML 0.01µ 50V K		BA07298A	Power Indicator P.C.B. Ass'y
C258L,R	OB01609A	CML 0.01µ 50V K		OB60608A	Power Indicator P.C.B.
C267L,R	OB09290A	CC 0.01µ 50V Z (TA-4E)	ED601	OB12421A	LED SPR-56PDWF GRN/RED
C268L,R	OB09290A	CC 0.01µ 50V Z (TA-4E)	CN21	OB83409A	2P Connector Ass'y
C269L,R	OB09290A	CC 0.01µ 50V Z (TA-4E)			
CN13	OB83420B	6P Connector 350mm			
	OB81950A	Speaker Terminal 8P (1)			

6.6. Volume Indicator P.C.B. Ass'y

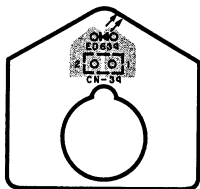

Fig. 6.6

6.7. Volume Motor P.C.B. Ass'y

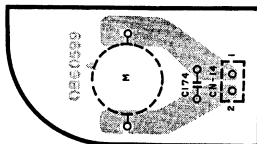

Fig. 6.7

6.8. Transistor Joint P.C.B. Ass'y

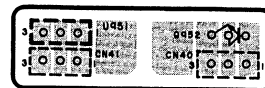

Fig. 6.8

6.9. Remote Control Sensor P.C.B. Ass'y

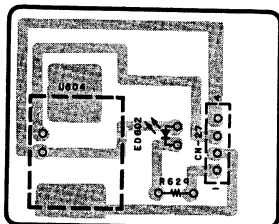

Fig. 6.9

6.10. IF Band Switch P.C.B. Ass'y

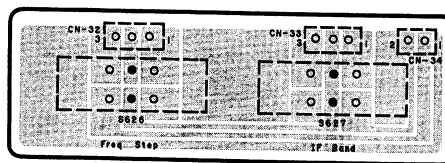

Fig. 6.10

6.11. Selector P.C.B. Ass'y

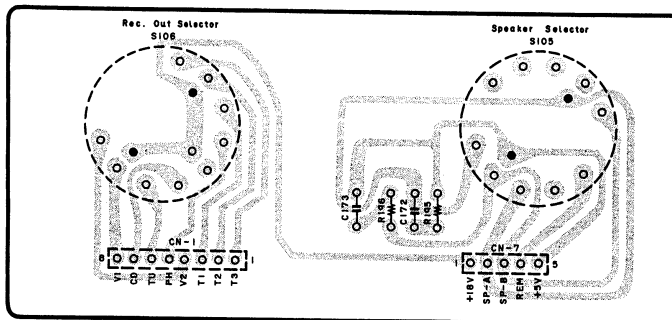

Fig. 6.11

Schematic Ref. No.	Part No.	Description	Schematic Ref. No.	Part No.	Description	Schematic Ref. No.	Part No.	Description
<b>6.6. Volume Indicator P.C.B. Ass'y</b>			<b>6.9. Remote Control Sensor P.C.B. Ass'y</b>			<b>6.11. Selector P.C.B. Ass'y</b>		
ED639	BA07320A	Volume Indicator P.C.B. Ass'y	U604 ED602	BA07297A	Remote Control Sensor P.C.B. Ass'y	R195,196 C172,173 S105	BA07286A	Selector P.C.B. Ass'y
	OB60611A	Volume Indicator P.C.B.		OB60607A	Remote Control Sensor P.C.B.		OB60596A	Selector P.C.B.
	OB12395A	LED SLR-34PC3F P-GRN		OB11511A OB12395A	IC BX1407 LED SLR-34PC3F P-Green		OB09653A	RK 100 1/6W J
<b>6.7. Volume Motor P.C.B. Ass'y</b>			R629 CN27	OB09662A OB83410A OJ05416A	RK 240 1/6W J 4P Connector Ass'y 400mm LED Reflector (1)	S106	OB70134A	Rotary Switch SRRM 2-5
C174 CN14	BA07289A	Volume Motor P.C.B. Ass'y	<b>6.10. IF Band Switch P.C.B. Ass'y</b>			CN1 CN7	OB70135A	Rotary Switch SRRM 1-9
	OB60599A	Volume Motor P.C.B.	S626,627 CN32 CN33 CN34	BA07543A	IF Band Switch P.C.B. Ass'y (TA-4)		OB83425B	8P Connector Ass'y 350mm
	OB41917A OB83401B	CC 0.1μ 25V Z 2P Connector 200mm		OB60609B	IF Band Switch P.C.B.		OB83413B	5P Connector Ass'y 300mm
<b>6.8. Transistor Joint P.C.B. Ass'y</b>				OB70137A OB83429B OB83428B OB83430B	Slide Switch C.Cable Ass'y 3P C.Cable Ass'y 3P C.Cable Ass'y 2P			
U951 Q952 CN40,41	BA07331A	Transistor Joint P.C.B. Ass'y						
	OB60613A	Transistor Joint P.C.B.						
	OB11526A OB06452A OB83437A	IC NJM78M12 TR 2SD1406 (Y) Flat Wire 3P						



6.12. Remote Jack P.C.B. Ass'y

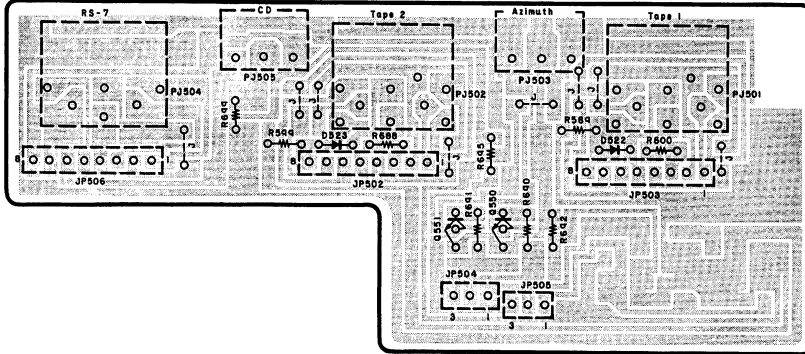

Fig. 6.12

6.13. Volume P.C.B. Ass'y

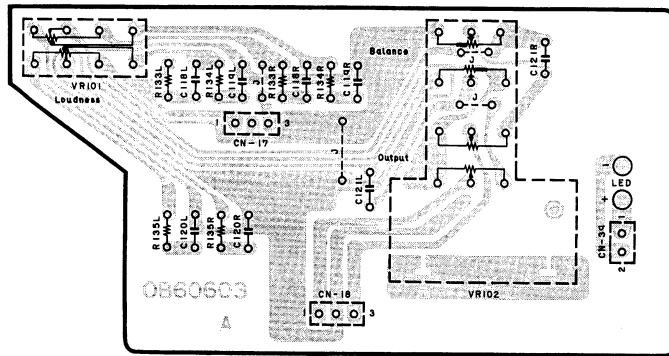

Fig. 6.13

6.14. Power Supply P.C.B. Ass'y

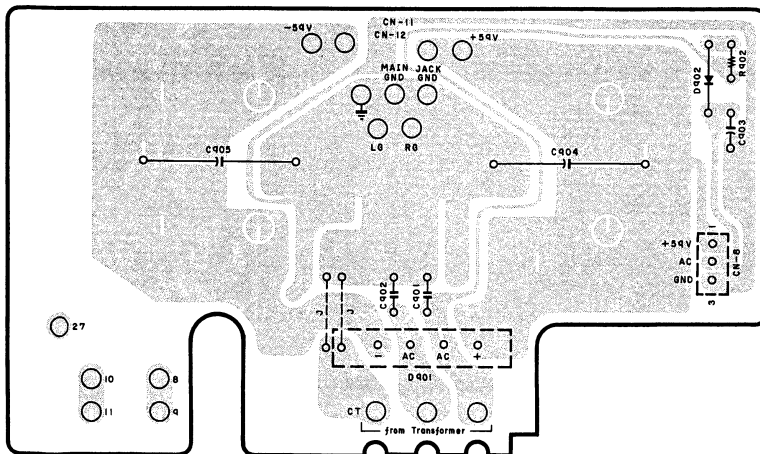

Fig. 6.14

Schematic Ref. No.	Part No.	Description
<b>6.12. Remote Jack P.C.B. Ass'y</b>		
	BA07323A	Remote Jack P.C.B. Ass'y
Q550,551	OB60614A	Remote Jack P.C.B.
D522,523	OB10113A	TR 2SC1815 (GR)
R589	OB06398A	SID 1SS176
R599	OB09637A	RK 22 1/6W J
R600	OB09637A	RK 22 1/6W J
R688	OB09677A	RK 1K 1/6W J
R690,691	OB09677A	RK 1K 1/6W J
R692	OB09717A	RK 47K 1/6W J
R695	OB09637A	RK 22 1/6W J
R699	OB09709A	RK 22K 1/6W J
PJ501,502	OB09637A	RK 22 1/6W J
PJ503	OB81754A	8P Din Socket
PJ504	OB81952A	ST Mini Jack
PJ505	OB81953A	6P Din Socket
	OB81952A	ST Mini Jack
	OJ05621A	Remote Jack Holder (1)
<b>6.13. Volume P.C.B. Ass'y</b>		
	BA07293A	Volume P.C.B. Ass'y
VR101	OB60603A	Volume P.C.B.
VR102	OB30091A	VR 300K
	OB30092A	Volume
R133L,R	OB09709A	250KMN+50KB
R134L,R	OB09699A	RK 22K 1/6W J
R135L,R	OB09707A	RK 8.2K 1/6W J
C118L,R	OB41274A	RK 18K 1/6W J
C119L,R	OB41290A	CML 1000P 50V J
C120L,R	OB41298A	CML 0.022μ 50V J
C121L,R	OB41298A	CML 0.1μ 50V J
CN17	OB41702A	CSP 22P 50V J
CN18	OB83422B	3P Connector 400mm
CN39	OB81760A	3P-T Post EH-3P WHT
	OB83424A	Cable Ass'y 2P
<b>6.14. Power Supply P.C.B. Ass'y</b>		
	BA07284A	Power Supply P.C.B. Ass'y
D901	OB60594B	Power Supply P.C.B.
D902	OB12617A	SID KBU8D
R902	OB12586A	SID 1N4002
C901,902	OB09711A	RK 27K 1/6W J
C903	OB41537A	CML 0.1μ 100V J
C904,905	OB40126A	CE 4.7μ 63V
CN8	OB40511A	CE 1200μ 71V
	OB83407B	3P Connector Ass'y 350mm
CN11	OB83418B	2P Connector Ass'y 400mm
CN12	OB83419B	2P Connector Ass'y 500mm
	OJ05625B	Heat Sink (1)
	OJ05701A	Transistor Silicon Rubber D (1)

6.15. Standby P.C.B. Ass'y

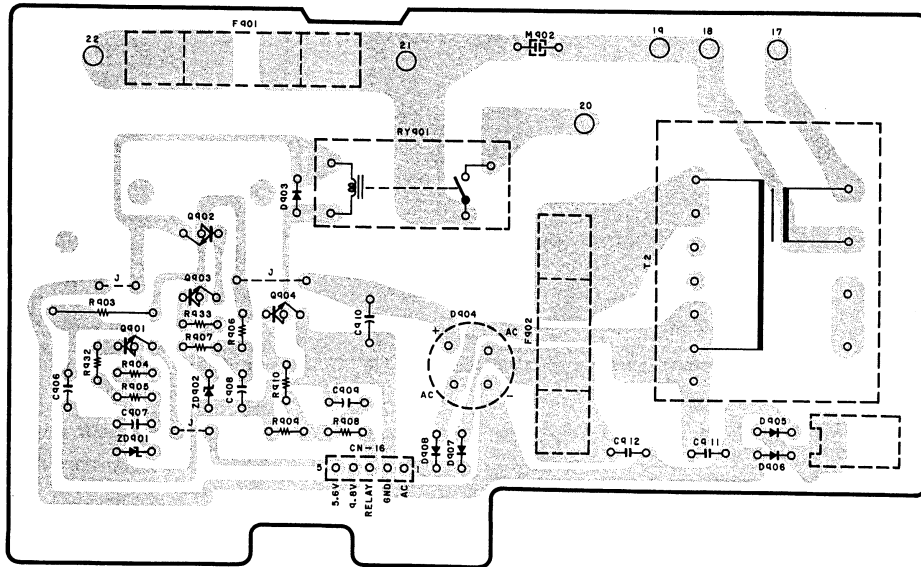

Fig. 6.15

6.16. Tone Control P.C.B. Ass'y

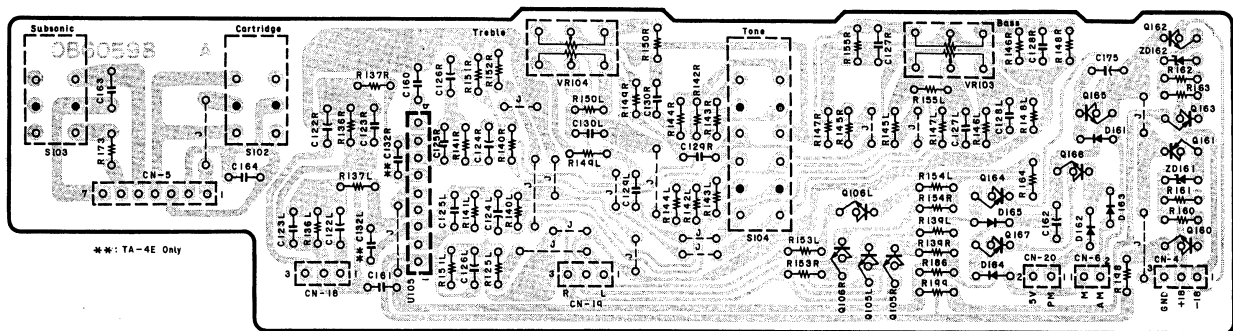

Fig. 6.16

Schematic Ref. No.	Part No.	Description	Schematic Ref. No.	Part No.	Description
<b>6.15. Standby P.C.B. Ass'y</b>			<b>6.16. Tone Control P.C.B. Ass'y</b>		
	BA07364A	Standby P.C.B. Ass'y (TA-4)		BA07288A	Tone Control P.C.B. Ass'y (TA-4/4A)
	BA07287A	Standby P.C.B. Ass'y (TA-4A)		BA07554A	Tone Control P.C.B. Ass'y (TA-4E)
	BA07365A	Standby P.C.B. Ass'y (TA-4E)			
Q901	OB60597A	Standby P.C.B.	U105	OB60598A	Tone Control P.C.B.
	OB06066A	TR 2SD471 (L,M)	Q105L,R	OB11512A	IC NJM5532SD
	OB06100A	TR 2SC945 (K,P,Q)	Q106L,R	OB06299A	TR 2SC2878
Q902	OB06452A	(TA-4A/4E)	Q160	OB06299A	TR 2SC2878
	OB06066A	TR 2SD1406	Q161	OB06142A	TR 2SC2240 (BL)
		(TA-4/4E)	Q162	OB06013A	TR 2SA733 (P,Q)
Q903	OB06100A	TR 2SD471 (L,M)	Q163	OB06100A	TR 2SC945 (K,P,Q)
Q904	OB06322A	(TA-4A)	Q164	OB10050A	TR 2SA970 (BL)
ZD901	OB12619A	TR 2SC945 (K,P,Q)	Q165	OB10053A	TR DTA144ES
		TR 2SC2002 (K,L)	Q166	OB10062A	TR DTC144ES
		ZD 6.8V	Q167	OB10062A	TR DTC144ES
		RD6.8ES-T1B2	ZD161,162	OB10053A	TR DTA144ES
ZD902	OB12623A	ZD 11V		OB12177A	ZD 13V
		RD11ES-T1B2			RD13JS-T1B2
D903	OB06398A	SID 1SS176	D161,162	OB06398A	SID 1SS176
D904	OB12604A	SID W02M	D163,164	OB06398A	SID 1SS176
D905,906	OB06398A	SID 1SS176	D165	OB06398A	SID 1SS176
D907,908	OB12624A	SID 1SS177	VR103	OB30093A	Volume 50KCx2
		(TA-4)	VR104	OB30094A	Volume 100KCx2
	OB06398A	SID 1SS176	R136L,R	OB09727A	RK 120K 1/6W J
R903	OB24200A	RF 56 1W J	R137L,R	OB25099A	RM 100 1/4W F
R904,905	OB09677A	RK 1K 1/6W J	R139L,R	OB09717A	RK 47K 1/6W J
R906,907	OB09669A	RK 470 1/6W J	R140L,R	OB09725A	RK 100K 1/6W J
R908	OB09677A	RK 1K 1/6W J	R141L,R	OB09749A	RK 1M 1/6W J
R909	OB09709A	RK 22K 1/6W J	R142L,R	OB22570A	RM 12.0K 1/4W F
R910	OB09629A	RK 10K 1/6W J	R143L,R	OB22570A	RM 12.0K 1/4W F
R932,933	OB09677A	RK 1K 1/6W J	R144L,R	OB25195A	RM 1.00K 1/4W F
C906	OB40121A	CE 220μ 50V	R145L,R	OB09703A	RK 12K 1/6W J
		(TA-4)	R146L,R	OB09705A	RK 15K 1/6W J
	OB40079A	CE 220μ 16V	R147L,R	OB09669A	RK 470 1/6W J
		(TA-4A/4E)	R148L,R	OB09684A	RK 2K 1/6W J
C907	OB40116A	CE 10μ 50V	R149L,R	OB09687A	RK 2.7K 1/6W J
		(TA-4)	R150L,R	OB09673A	RK 680 1/6W J
C908	OB01412A	CE 10μ 16V	R151L,R	OB09725A	RK 100K 1/6W J
		(TA-4A/4E)	R152L,R	OB25195A	RM 1.00K 1/4W F
	OB40119A	CE 47μ 50V	R153L,R	OB09653A	RK 100 1/6W J
		(TA-4)	R154L,R	OB09717A	RK 47K 1/6W J
	OB01403A	CE 47μ 16V	R155L,R	OB09723A	RK 82K 1/6W J
		(TA-4A/4E)	R160	OB09685A	RK 2.2K 1/6W J
C909	OB01836A	CE 47μ 10V	R161,162	OB09695A	RK 5.6K 1/6W J
C910	OB40335A	CE 470μ 50V	R163	OB09685A	RK 2.2K 1/6W J
		(TA-4)	R164	OB09725A	RK 100K 1/6W J
	OB40081A	CE 470μ 16V	R173	OB09731A	RK 180K 1/6W J
		(TA-4A/4E)	R186	OB09725A	RK 100K 1/6W J
C911,912	OB01603A	CML 0.1μ 50V K	R198,199	OB09645A	RK 47 1/6W J
RY901	OB90332A	Relay 12V	C122L,R	OB40612A	CE 0.33μ 50V (LN)
		12MB-NR-UL,TV-8	C123L,R	OB41788A	CSP 220P 50V J
		(TA-4/4A)	C124L,R	OB09933A	CE 2.2μ 50V (LN)
	OB90334A	Relay 12V	C125L,R	OB41922A	CSP 47P 50V J
		12MB-VD3 TV-5	C126L,R	OB09933A	CE 2.2μ 50V (LN)
		(TA-4E)	C127L,R	OB41296A	CML 0.068μ 50V J
F901	OB90354A	Fuse 6A 125V	C128L,R	OB41305A	CML 0.39μ 50V J
		(TA-4/4A)	C129L,R	OB09189A	CML 2700P 50V J
	OB90356A	Fuse T3.15A 250V	C130L,R	OB05832A	CML 0.018μ 50V J
		(TA-4E)	C132L,R	OB41735A	CC 100P 50V J
F902	OB90335A	Fuse 0.5A 250V	C160,161	OB41298A	CML 0.1μ 50V J
		(TA-4/4A)	C162	OB01400A	CE 100μ 16V
	OB90288A	Fuse T500mA 250V	C163,164	OB01603A	CML 0.1μ 50V K
		(TA-4E)	C175	OB01405A	CE 1μ 50V
CN16	OB83414B	5P Connector Ass'y 400mm	S102,103	OB70132A	Push Switch
M902	OB41829A	CC 4700P 100V Z			SPUN2-2
	OE00510A	M3x8 @Pan (2A)		OB70133A	Push Switch
		(TA-4) (1)	CN4		SPUN4-2
	OJ05670A	Earth Plate (1)	CN5	OB83408B	3P Connector Ass'y 450mm
	OJ05846A	Heat Sink (1)	CN6	OB83415B	7P Connector Ass'y 330mm
	OB80204A	Terminal Pin (K) (1)	CN18	OB83404B	2P Connector Ass'y 350mm
	OB81930A	Fuse Holder SN-5051 (TA-4/4A) (4)	CN19	OB83421B	3P Connector Ass'y 250mm
	OB81848A	Fuse Holder Z-N1152 (TA-4E) (4)	CN20	OB83423B	3P Connector Ass'y 400mm
	OM03936B	Fuse Label T3.15A 250V (TA-4E) (1)		OB83403B	2P Connector Ass'y 270mm
	OM04096C	Fuse Label T500mA 250V (TA-4E) (2)			

6.17. Control Switch & Display P.C.B. Ass'y

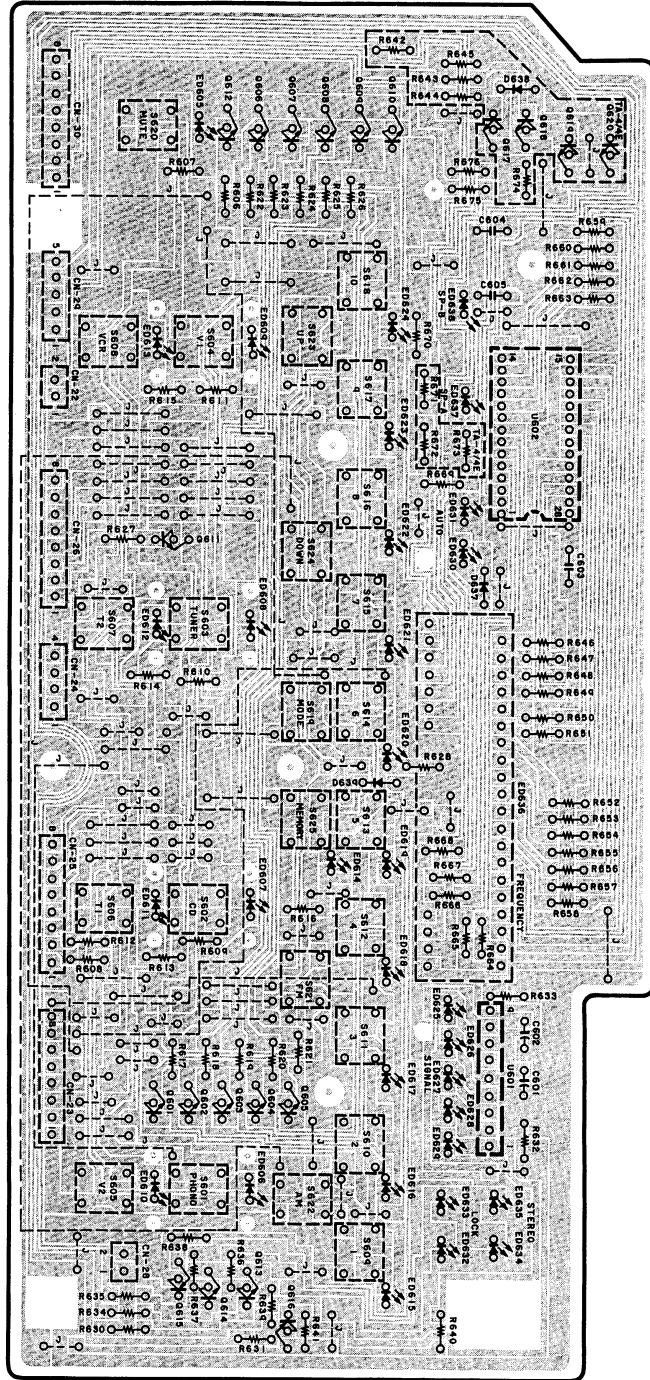

Fig. 6.17

Schematic Ref. No.	Part No.	Description	Schematic Ref. No.	Part No.	Description
<b>6.1.7. Control Switch &amp; Display P.C.B. Ass'y</b>			R636,637	OB09655A	RK 120 1/6W J
	BA07363A	Control Switch & Display P.C.B. Ass'y (TA-4/4E)	R638	OB09655A	RK 120 1/6W J
	BA07294A	Control Switch & Display P.C.B. Ass'y (TA-4A)	R639,640	OB09717A	RK 47K 1/6W J
			R641	OB09717A	RK 47K 1/6W J
			R642	OB09701A	RK 10K 1/6W J
				(TA-4/4E)	
	OB60604B	Control Switch & Display P.C.B.	R643,644	OB09693A	RK 4.7K 1/6W J
				(TA-4/4E)	
			R645	OB09693A	RK 4.7K 1/6W J
				(TA-4/4E)	
U601	OB11244A	IC LB1413N	R646,647	OB09662A	RK 240 1/6W J
U602	OB11523A	IC TD6301AN	R648,649	OB09662A	RK 240 1/6W J
Q601,602	OB10257A	TR 2SC2021 (S)	R650,651	OB09662A	RK 240 1/6W J
Q603,604	OB10257A	TR 2SC2021 (S)	R652,653	OB09662A	RK 240 1/6W J
Q605,606	OB10257A	TR 2SC2021 (S)	R654,655	OB09662A	RK 240 1/6W J
Q607,608	OB10257A	TR 2SC2021 (S)	R656,657	OB09662A	RK 240 1/6W J
Q609,610	OB10257A	TR 2SC2021 (S)	R658,659	OB09662A	RK 240 1/6W J
Q611,612	OB10257A	TR 2SC2021 (S)	R660,661	OB09662A	RK 240 1/6W J
Q613,614	OB10257A	TR 2SC2021 (S)	R662,663	OB09662A	RK 240 1/6W J
Q615,616	OB10256A	TR 2SA937 (R)	R664,665	OB09662A	RK 240 1/6W J
Q617,618	OB10257A	TR 2SC2021 (S)	R666	OB09662A	RK 240 1/6W J
		(TA-4/4E)	R667	OB09655A	RK 120 1/6W J
Q619,620	OB10257A	TR 2SC2021 (S)	R668	OB09679A	RK 1.2K 1/6W J
		(TA-4/4E)	R669,670	OB09668A	RK 430 1/6W J
D637	OB06398A	SID 1SS176	R671,672	OB09655A	RK 120 1/6W J
D638	OB06398A	SID 1SS176		(TA-4/4E)	
		(TA-4/4E)	R673	OB09662A	RK 240 1/6W J
D639	OB06398A	SID 1SS176		(TA-4/4E)	
ED605,606	OB12395A	LED SLR-34PC3F P-Green	R674	OB09655A	RK 120 1/6W J
ED607,608	OB12395A	LED SLR-34PC3F P-Green		(TA-4/4E)	
ED609,610	OB12395A	LED SLR-34PC3F P-Green	R675,676	OB09659A	RK 180 1/6W J
ED611,612	OB12395A	LED SLR-34PC3F P-Green	C601,602	OB40162A	CE 10μ 16V
ED613,614	OB12395A	LED SLR-34PC3F P-Green	C603	OB41787A	CC 0.022μ 25V Z
ED615,616	OB12395A	LED SLR-34PC3F P-Green	C604,605	OB41911A	CC 470P 50V J
ED617,618	OB12395A	LED SLR-34PC3F P-Green	S601,602	OB70043A	Tact Switch SKHHPM
ED619,620	OB12395A	LED SLR-34PC3F P-Green	S603,604	OB70043A	Tact Switch SKHHPM
ED621,622	OB12395A	LED SLR-34PC3F P-Green	S605,606	OB70043A	Tact Switch SKHHPM
ED623,624	OB12395A	LED SLR-34PC3F P-Green	S607,608	OB70043A	Tact Switch SKHHPM
ED625,626	OB12625A	LED SLR-34PG3F P-Green	S609,610	OB70043A	Tact Switch SKHHPM
ED627,628	OB12625A	LED SLR-34PG3F P-Green	S611,612	OB70043A	Tact Switch SKHHPM
ED629,630	OB12625A	LED SLR-34PG3F P-Green	S613,614	OB70043A	Tact Switch SKHHPM
ED631,632	OB12625A	LED SLR-34PG3F P-Green	S615,616	OB70043A	Tact Switch SKHHPM
ED633,634	OB12625A	LED SLR-34PG3F P-Green	S617,618	OB70043A	Tact Switch SKHHPM
ED635	OB12625A	LED SLR-34PG3F P-Green	S619,620	OB70043A	Tact Switch SKHHPM
ED636	OB12616A	LED Display LTF2501 (TA-4/4E)	S621,622	OB70043A	Tact Switch SKHHPM
			S623,624	OB70043A	Tact Switch SKHHPM
	OB12608A	LED Display LTF2401 (TA-4A)	S625	OB70043A	Tact Switch SKHHPM
ED637,638	OB12625A	LED SLR-34PG3F P-Green	CN22	OB83402B	2P Connector Ass'y 250mm
R606	OB09707A	RK 18K 1/6W J	CN23	OB83380A	8P Flat Cable 230mm
R607	OB09662A	RK 240 1/6W J	CN24	OB83376A	4P Flat Cable 170mm
R608,609	OB09681A	RK 1.5K 1/6W J	CN25,26	OB83378A	8P Flat Cable 170mm
R610,611	OB09681A	RK 1.5K 1/6W J	CN28	OB83405B	2P Connector Ass'y 450mm
R612,613	OB09681A	RK 1.5K 1/6W J	CN29	OB83377A	5P Flat Cable 170mm
R614,615	OB09681A	RK 1.5K 1/6W J	CN30	OB83379A	8P Flat Cable 190mm
R616	OB09662A	RK 240 1/6W J		OH05336A	Display Reflector (1)
R617,618	OB09707A	RK 18K 1/6W J		OH05345A	Display Overlay (1)
R619,620	OB09707A	RK 18K 1/6W J		OJ05634A	Diffuser Sheet A (1)
R621,622	OB09707A	RK 18K 1/6W J		OJ05635B	Diffuser Sheet B (1)
R623,624	OB09707A	RK 18K 1/6W J		OJ05416A	LED Reflector (8)
R625,626	OB09707A	RK 18K 1/6W J			
R627	OB09707A	RK 18K 1/6W J			
R628	OB09662A	RK 240 1/6W J			
R630	OB09717A	RK 47K 1/6W J			
R631	OB09677A	RK 1K 1/6W J			
R632	OB09701A	RK 10K 1/6W J			
R633	OB09677A	RK 1K 1/6W J			
R634,635	OB09701A	RK 10K 1/6W J			

6.18. Tuner P.C.B. Ass'y

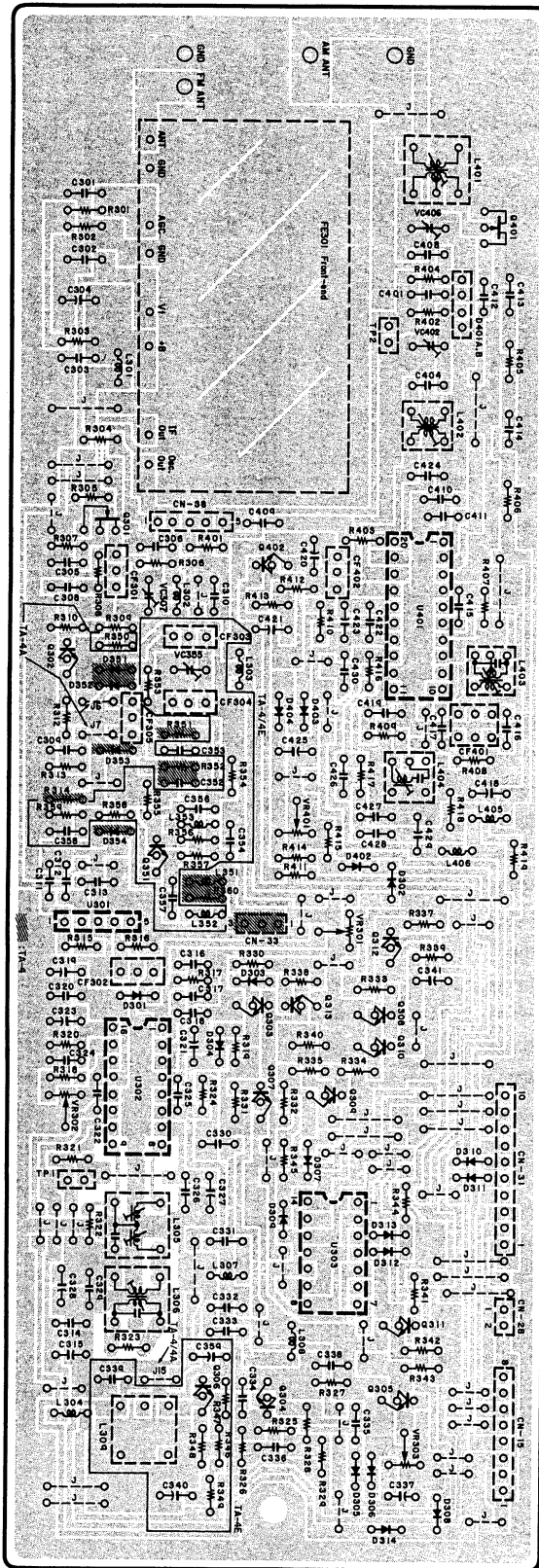

Fig. 6.18

Schematic Ref. No.	Part No.	Description	Schematic Ref. No.	Part No.	Description	Schematic Ref. No.	Part No.	Description
<b>6.18. Tuner P.C.B. Ass'y</b>								
	BA07357A	Tuner P.C.B. Ass'y (TA-4)	R310	OB09686A	RK 2.4K 1/6W J	C301	OB41787A	CC 0.022μ 25V Z
	BA07295A	Tuner P.C.B. Ass'y (TA-4A)	R312	OB09645A	RK 47 1/6W J	C302	OB41294A	CML 0.047μ 50V J
	BA07358A	Tuner P.C.B. Ass'y (TA-4E)	R313	OB09667A	RK 390 1/6W J	C303	OB41290A	CML 0.022μ 50V J
			R314	OB09689A	RK 3.3K 1/6W J	C304	OB40420A	CE 220μ 16V (LN)
			R315,316	OB09667A	RK 390 1/6W J	C305,306	OB41787A	CC 0.022μ 25V Z
			R317	OB09665A	RK 330 1/6W J	C308,309	OB41787A	CC 0.022μ 25V Z
			R318	OB09677A	RK 1K 1/6W J	C310,311	OB41787A	CC 0.022μ 25V Z
			R319	OB09701A	RK 10K 1/6W J	C312	OB41787A	CC 0.022μ 25V Z
			R320	OB09719A	RK 56K 1/6W J	C313,314	OB41290A	CML 0.022μ 50V J
			R321	OB09705A	RK 15K 1/6W J	C315	OB40420A	CE 220μ 16V (LN)
U301	OB60605A	Tuner P.C.B.		OB09701A	RK 10K 1/6W J	C316,317	OB41787A	CC 0.022μ 25V Z
U302	OB11156A	IC TA7060AP			(TA-4/E)	C318	OB41787A	CC 0.022μ 25V Z
U303	OB11157A	IC LA1235			(TA-4A)	C319	OB41787A	CC 4.7μ 25V
U401	OB06219A	IC μPD4081BC			(TA-4A)	C320	OB41787A	CC 0.022μ 25V Z
Q301	OB11243A	IC LA1247	R322	OB09699A	RK 8.2K 1/6W J	C321	OB09372A	CE 2.2μ 50V
Q302	OB10127A	FET 2SK241 (GR)	R323	OB25228A	RM 2.21K 1/6W F	C322	OB41787A	CC 0.022μ 25V Z
Q303,304	OB10174A	TR 2SC2669 (O,Y)	R324	OB09677A	RK 1K 1/6W J	C323	OB41405A	CE 1μ 50V
Q305	OB06100A	TR 2SC945 (K,P,Q)	R325	OB09727A	RK 120K 1/6W J	C324	OB41787A	CC 0.022μ 25V Z
Q306	OB06100A	TR 2SC945 (K,P,Q)	R326	OB09705A	RK 15K 1/6W J	C325	OB41909A	CC 100P 50V J
	OB10025A	(TA-4E)	R327	OB09669A	RK 470 1/6W J	C326	OB41787A	CC 0.022μ 25V Z
Q307,308	OB06100A	TR 2SC945 (K,P,Q)	R328	OB09693A	RK 4.7K 1/6W J	C327	OB01405A	CE 1μ 50V
Q309	OB06013A	TR 2SA733 (P,Q)	R329	OB09677A	RK 1K 1/6W J	C328	OB40066A	CE 330μ 10V
Q310	OB10068A	TR DTC114ES	R330	OB09717A	RK 47K 1/6W J	C329	OB41787A	CC 0.022μ 25V Z
Q311,312	OB06100A	TR 2SC945 (K,P,Q)	R331	OB09725A	RK 100K 1/6W J	C330	OB41907A	CC 47P 50V J
Q313	OB06100A	TR 2SC945 (K,P,Q)	R332	OB09701A	RK 10K 1/6W J	C331	OB41787A	CC 1000P 50V Z
Q351	OB10174A	TR 2SC945 (K,P,Q)	R333	OB09717A	RK 47K 1/6W J	C332	OB41907A	CC 47P 50V J
		(TA-4/E)	R334,335	OB09701A	RK 10K 1/6W J	C333	OB41921A	CSP 560P 50V J
Q401	OB06129A	FET 2SK117 (Y)	R337,338	OB09701A	RK 10K 1/6W J	C334	OB41907A	CC 47P 50V J
Q402	OB06100A	TR 2SC945 (K,P,Q)	R339	OB09707A	RK 18K 1/6W J	C335,336	OB41787A	CC 0.022μ 25V Z
D301	OB06398A	SID 1SS176	R340	OB09725A	RK 100K 1/6W J	C337	OB41787A	CE 1μ 50V
D302,303	OB06398A	SID 1SS176	R341	OB09701A	RK 10K 1/6W J	C338	OB41787A	CC 0.022μ 25V Z
D304,305	OB06398A	SID 1SS176	R342,343	OB09717A	RK 47K 1/6W J	C339	OB41219A	CPP 560P 100V
D306,307	OB06398A	SID 1SS176	R344,345	OB09701A	RK 10K 1/6W J			(TA-4E)
D308,309	OB06398A	SID 1SS176	R346	OB09694A	RK 5.1K 1/6W J	C340	OB01400A	CE 100μ 16V
D310,311	OB06398A	SID 1SS176			(TA-4E)			(TA-4E)
D312,313	OB06398A	SID 1SS176	R347	OB09745A	RK 680K 1/6W J	C341	OB01405A	CE 1μ 50V
D314	OB06398A	SID 1SS176			(TA-4E)	C352	OB41787A	CC 0.022μ 25V
D351,352	OB06398A	SID 1SS176	R348	OB09687A	RK 2.7K 1/6W J			(TA-4)
		(TA-4)	R349	OB09669A	RK 470 1/6W J	C353,354	OB41787A	CC 0.022μ 25V
D353,354	OB06398A	SID 1SS176	R350	OB09665A	RK 330 1/6W J	C356,357	OB41787A	CC 0.022μ 25V
		(TA-4)	R351	OB09665A	RK 330 1/6W J	C358	OB41787A	CC 0.022μ 25V
D401	OB12386A	Varicap KV1226Y	R352	OB09693A	RK 4.7K 1/6W J	C359	OB01412A	CE 10μ 16V
D402	OB12363A	SID MA700	R353	OB09665A	RK 330 1/6W J	C401	OB41787A	CC 0.022μ 25V Z
D403,404	OB06398A	SID 1SS176	R354	OB09665A	RK 330 1/6W J	C404	OB41920A	CSP 430P 50V J
CF301,302	OB41918A	Ceramic Filter SFE10.7MLA	R355	OB09689A	RK 3.3K 1/6W J	C408,409	OB41787A	CC 0.022μ 25V Z
CF303,304	OB41746A	Ceramic Filter SFE10.7MS3GH15A	R356	OB09698A	RK 7.5K 1/6W J	C410	OB41912A	CC 1000P 50V Z
		(TA-4/E)	R357	OB09671A	RK 560 1/6W J	C411,412	OB41787A	CC 0.022μ 25V Z
CF305	OB41918A	Ceramic Filter SFE10.7MLA	R358	OB09650A	RK 75 1/6W J	C413	OB41912A	CC 1000P 50V Z
CF401	OB41701A	Ceramic Filter SFZ450G3L	R359	OB09646A	RK 51 1/6W J	C414,415	OB41787A	CC 0.022μ 25V Z
CF402	OB92003A	Ceramic Resonator 450KHz	R360	OB09677A	RK 1K 1/6W J	C416	OB41908A	CC 82P 50V J
		BFU450C4N	R401	OB09693A	RK 4.7K 1/6W J	C417	OB41787A	CC 0.022μ 25V Z
L301,302	OB51239A	Coil 22μH (K)	R402	OB09677A	RK 1K 1/6W J	C418	OB01403A	CE 47μ 16V
L303,304	OB51239A	Coil 22μH (K)	R403	OB09725A	RK 100K 1/6W J	C419	OB41912A	CC 1000P 50V Z
L305	OB51240A	FM DET Coil A	R404	OB09685A	RK 2.2K 1/6W J	C420,421	OB01402A	CE 4.7μ 25V
L306	OB51241A	FM DET Coil B	R405	OB09661A	RK 320 1/6W J	C422	OB41787A	CC 0.022μ 25V Z
L307,308	OB51243A	Choke Coil 6.2mH	R406	OB09681A	RK 1.5K 1/6W J	C423	OB40111A	CE 0.47μ 50V
L309	OB51288A	L.P.F. Filter (TA-4E)	R408	OB09685A	RK 2.2K 1/6W J	C424	OB41787A	CC 0.022μ 25V Z
		(TA-4E)	R409	OB09674A	RK 750 1/6W J	C425	OB09372A	CE 2.2μ 50V
L351	OB51239A	Coil 22μH (K)	R410	OB09651A	RK 82 1/6W J	C426	OB41787A	CC 0.022μ 25V Z
		(TA-4)	R411	OB09677A	RK 220K 1/6W J	C427	OB41913A	CC 2200P 50V M
L352,353	OB51239A	Coil 22μH (K)	R412,413	OB09701A	RK 10K 1/6W J	C428	OB41292A	CML 0.033μ 50V J
		(TA-4/E)	R414	OB09708A	RK 20K 1/6W J	C429	OB01403A	CE 47μ 16V
L401	OB51282A	ANT Coil	R415	OB09701A	RK 10K 1/6W J	C430	OB41914A	CC 0.01μ 50V Z
L402	OB51279A	OSC Coil	R416	OB09677A	RK 1K 1/6W J	TP1,2	OB81759A	2P-T Post EH-2P
L403	OB51280A	AM IFT1 Coil	R417	OB09685A	RK 2.2K 1/6W J	PJ301	OB81977A	Antenna Terminal F
L404	OB51281A	AM IFT2 Coil	R418	OB09677A	RK 1K 1/6W J			(TA-4/4A)
L405,406	OB51239A	Coil 22μH (K)	R419	OB09725A	RK 100K 1/6W J			Antenna Terminal F
VR301	OB32084A	Semi VR 47KB	R420	OB09709A	RK 22K 1/6W J	FE301	OB91016A	Front-end FE407-A16
VR302	OB32080A	Semi VR 10KB	VC307	OB42012A	C Trimmer 30P			(TA-4/4A)
VR303	OB32084A	Semi VR 47KB	VC355	OB42012A	C Trimmer 30P			Front-end FE407-G58
VR401	OB32086A	Semi VR 100KB	VC402	OB42011A	C Trimmer 20P			(TA-4E)
R301	OB09725A	RK 100K 1/6W J	VC406	OB42011A	C Trimmer 20P			Terminal Holder (2)
R302	OB09721A	RK 68K 1/6W J						
R303	OB09727A	RK 120K 1/6W J						
R304	OB09677A	RK 1K 1/6W J						
R305	OB09745A	RK 680K 1/6W J						
R306	OB09665A	RK 330 1/6W J						
R307	OB09645A	RK 47 1/6W J						
R308	OB09667A	RK 390 1/6W J						
R309	OB09698A	RK 7.5K 1/6W J						

Schematic Ref. No.	Part No.	Description	Schematic Ref. No.	Part No.	Description	Schematic Ref. No.	Part No.	Description
<b>6.19. Video &amp; Logic P.C.B. Ass'y</b>			D516	OB06398A	SID 1SS176	R575,576	OB01846A	RK 4.7K 1/4W J
			D517	OB06181A	SID 1SS53	R577	OB01846A	RK 4.7K 1/4W J
	BA07360A	Video & Logic P.C.B. Ass'y (TA-4)	D518,519	OB06398A	SID 1SS176	R578,579	OB09693A	RK 4.7K 1/6W J
			D520,521	OB06398A	SID 1SS176	R580	OB09693A	RK 4.7K 1/6W J
	BA07296A	Video & Logic P.C.B. Ass'y (TA-4A)	D524,525	OB06398A	SID 1SS176	R581,582	OB05641A	RK 47K 1/4W J
			D526,527	OB06398A	SID 1SS176	R583,584	OB05641A	RK 47K 1/4W J
	BA07361A	Video & Logic P.C.B. Ass'y (TA-4E)	D528,529	OB06398A	SID 1SS176	R585,586	OB05641A	RK 47K 1/4W J
			D530	OB06398A	SID 1SS176	R587,588	OB05641A	RK 47K 1/4W J
			D531	OB06181A	SID 1SS53	R590,591	OB09717A	RK 47K 1/6W J
			D532	OB06398A	SID 1SS176	R592,593	OB09717A	RK 47K 1/6W J
			D534	OB06398A	SID 1SS176	R594,595	OB09717A	RK 47K 1/6W J
			D535	OB06181A	SID 1SS53	R596,597	OB09717A	RK 47K 1/6W J
	OB60606A	Video & Logic P.C.B.	D951	OB12604A	SID W02M	R598	OB09717A	RK 47K 1/6W J
			D953,954	OB06398A	SID 1SS176	R601,602	OB09733A	RK 220K 1/6W J
U501	OB11250A	IC LB1645N	D955	OB06398A	SID 1SS176	R603,604	OB09733A	RK 220K 1/6W J
U502	OB06143A	IC $\mu$ PD4001BC	D956	OB12604A	SID W02M	R681,682	OB09717A	RK 47K 1/6W J
U503	OB06219A	IC $\mu$ PD4081BC	D957,958	OB06398A	SID 1SS176	R683,684	OB09717A	RK 47K 1/6W J
U504	OB11513A	IC $\mu$ PD74HC237	D959,960	OB12624A	SID 1SS177	R685,686	OB09717A	RK 47K 1/6W J
U505	OB11502A	IC $\mu$ PD75104CW	D961,962	OB12586A	SID 1N4002	R687	OB09717A	RK 47K 1/6W J
U506	OB11161A	IC TC9147BP	D963	OB06398A	SID 1SS176	R693,694	OB09681A	RK 1.5K 1/6W J
U507	OB11159A	IC TD6104P	D966,967	OB06398A	SID 1SS176	R696,697	OB09701A	RK 10K 1/6W J
U952	OB11248A	IC ICP-N5	D968,969	OB06398A	SID 1SS176	R698	OB09709A	RK 22K 1/6W J
U953	OB11335A	IC ICP-N15	D1001	OB12604A	SID W02M	R951	OB09665A	RK 330 1/6W J
U1001,1002	OB06169A	IC TC4066BP	D1003,1004	OB06398A	SID 1SS176	R952	OB09669A	RK 470 1/6W J
Q501,502	OB10113A	TR 2SC1815 (GR)	D1005,1006	OB06398A	SID 1SS176	R953,954	OB09686A	RK 2.2K 1/6W J
Q503	OB10113A	TR 2SC1815 (GR)	D1007,1008	OB06398A	SID 1SS176	R955	OB09685A	RK 2.2K 1/6W J
Q504	OB10116A	TR 2SA1015 (GR)	D1009,1010	OB06398A	SID 1SS176	R956	OB09695A	RK 5.6K 1/6W J
Q505,506	OB10113A	TR 2SC1815 (GR)	X501	OB92014A	Ceramic Resonator 4MHz	R957	OB09733A	RK 220K 1/6W J
Q507,508	OB10116A	TR 2SA1015 (GR)	X502	OB92006A	X"Tal 7.2MHz	R958	OB09725A	RK 100K 1/6W J
Q509,510	OB10116A	TR 2SA1015 (GR)	L501	OB51239A	Coil 22 $\mu$ H	R959	OB09709A	RK 22K 1/6W J
Q511	OB10068A	TR DTC114ES	L502	OB51286A	Coil 470 $\mu$ H	R960	OB09707A	RK 18K 1/6W J
Q512,513	OB10113A	TR 2SC1815 (GR)	R500	OB09677A	RK 1K 1/6W J	R961	OB09693A	RK 4.7K 1/6W J
Q514,515	OB10088A	TR 2SC1815L (GR) (Low Noise)	R501	OB09725A	RK 100K 1/6W J	R962	OB09727A	RK 120K 1/6W J
			R502	OB09707A	RK 18K 1/6W J	R963	OB09719A	RK 56K 1/6W J
Q516,517	OB10113A	TR 2SC1815 (GR)	R503	OB09695A	RK 5.6K 1/6W J	R964	OB09721A	RK 68K 1/6W J
Q518,519	OB10113A	TR 2SC1815 (GR)	R504	OB09697A	RK 6.8K 1/6W J	R965,966	OB09725A	RK 100K 1/6W J
Q520,521	OB10113A	TR 2SC1815 (GR)	R505,506	OB09725A	RK 100K 1/6W J	R967	OB09717A	RK 47K 1/6W J
Q522,523	OB10113A	TR 2SC1815 (GR)	R507	OB01888A	RK 10K 1/4W J	R968	OB09701A	RK 10K 1/6W J
Q524,525	OB10116A	TR 2SA1015 (GR)	R508	OB09669A	RK 470 1/6W J	R969	OB09694A	RK 5.1K 1/6W J
Q526,527	OB10116A	TR 2SA1015 (GR)	R509	OB09701A	RK 10K 1/6W J	R970,971	OB09701A	RK 10K 1/6W J
Q528,529	OB10116A	TR 2SA1015 (GR)	R510,511	OB09695A	RK 5.6K 1/6W J	R972	OB09694A	RK 5.1K 1/6W J
Q530,531	OB10116A	TR 2SA1015 (GR)	R512	OB09689A	RK 3.3K 1/6W J	R973	OB09701A	RK 10K 1/6W J
Q532	OB10116A	TR 2SA1015 (GR)	R513	OB09688A	RK 1.8K 1/6W J	R1001	OB09681A	RK 1.5K 1/6W J
Q533,534	OB10113A	TR 2SC1815 (GR)	R514	OB09689A	RK 3.3K 1/6W J	R1002	OB09725A	RK 100K 1/6W J
Q535,536	OB10113A	TR 2SC1815 (GR)	R515,516	OB09661A	RK 220 1/6W J	R1003	OB09701A	RK 10K 1/6W J
Q537,538	OB10113A	TR 2SC1815 (GR)	R517	OB09701A	RK 10K 1/6W J	R1004	OB09649A	RK 68 1/6W J
Q539,540	OB10113A	TR 2SC1815 (GR)	R518	OB09725A	RK 100K 1/6W J	R1005	OB09661A	RK 220 1/6W J
Q541,542	OB10113A	TR 2SC1815 (GR)	R519	OB09661A	RK 220 1/6W J	R1006	OB20514A	RK 100 1/2W J
Q543,544	OB10113A	TR 2SC1815 (GR)	R520,521	OB09701A	RK 10K 1/6W J	R1007	OB09669A	RK 470 1/6W J
Q545,546	OB10113A	TR 2SC1815 (GR)	R522,523	OB09725A	RK 100K 1/6W J	R1008	OB09683A	RK 1.8K 1/6W J
Q547,548	OB10113A	TR 2SC1815 (GR)	R524,525	OB09725A	RK 100K 1/6W J	R1009	OB09669A	RK 1.8K 1/6W J
Q552,553	OB10113A	TR 2SC1815 (GR)	R526,527	OB09725A	RK 100K 1/6W J	R1010	OB09677A	RK 47K 1/6W J
Q554,555	OB10113A	TR 2SC1815 (GR)	R528	OB09725A	RK 100K 1/6W J	R1011	OB09665A	RK 330 1/6W J
Q556	OB10113A	TR 2SC1815 (GR)	R529	OB09717A	RK 47K 1/6W J	R1012	OB09679A	RK 1.2K 1/6W J
Q557	OB10062A	TR DTC144ES	R530	OB09663A	RK 270 1/6W J	R1013	OB09691A	RK 3.9K 1/6W J
Q951	OB10113A	TR 2SC1815 (GR)	R531	OB09693A	RK 4.7K 1/6W J	R1014	OB09651A	RK 82 1/6W J
Q953	OB06142A	TR 2SC2240 (BL)	R532	OB09717A	RK 47K 1/6W J	R1015	OB09701A	RK 10K 1/6W J
Q954,955	OB10113A	TR 2SC1815 (GR)	R533,534	OB09677A	RK 1K 1/6W J	R1016	OB09649A	RK 68 1/6W J
Q956	OB10116A	TR 2SA1015 (GR)	R535,536	OB09677A	RK 1K 1/6W J	R1017	OB20514A	RK 100 1/2W J
Q957	OB10113A	TR 2SC1815 (GR)	R537,538	OB09677A	RK 1K 1/6W J	R1018	OB09661A	RK 220 1/6W J
Q958	OB06013A	TR 2SA733 (P,Q)	R539,540	OB09677A	RK 1K 1/6W J	R1019	OB09669A	RK 470 1/6W J
Q959	OB10113A	TR 2SC1815 (GR)	R541,542	OB09677A	RK 1K 1/6W J	R1020	OB09683A	RK 1.8K 1/6W J
Q960	OB06013A	TR 2SA733 (P,Q)	R543,544	OB09677A	RK 1K 1/6W J	R1021	OB09677A	RK 1K 1/6W J
Q961	OB10113A	TR 2SC1815 (GR)	R545,546	OB09677A	RK 1K 1/6W J	R1022	OB09669A	RK 470 1/6W J
Q1001	OB06452A	TR 2SD1406 (Y)	R547	OB09693A	RK 4.7K 1/6W J	R1023	OB09665A	RK 330 1/6W J
Q1002	OB06100A	TR 2SC945 (K,P,Q)	R548	OB09725A	RK 100K 1/6W J	R1024	OB09691A	RK 3.9K 1/6W J
Q1003	OB06013A	TR 2SA733 (P,Q)	R549	OB09701A	RK 10K 1/6W J	R1025	OB09679A	RK 1.2K 1/6W J
Q1004,1005	OB06100A	TR 2SC945 (K,P,Q)	R551,552	OB09739A	RK 390K 1/6W J	R1026	OB08651A	RK 82 1/6W J
Q1006	OB06013A	TR 2SA733 (P,Q)	R553,554	OB09709A	RK 22K 1/6W J	R1027,1028	OB08650A	RK 75 1/6W J
Q1007	OB06100A	TR 2SC945 (K,P,Q)	R555	OB09685A	RK 2.2K 1/6W J	R1029	OB09650A	RK 75 1/6W J
Q1008	OB10116A	TR 2SA1015 (GR)	R556	OB09701A	RK 10K 1/6W J	R1030,1031	OB05776A	RK 1M 1/4W J
ZD504	OB12622A	ZD 5.6V	R557	OB20093A	RK 1.5M 1/6W J	R1032,1033	OB05776A	RK 1M 1/4W J
			R558	OB09731A	RK 180K 1/6W J	R1034,1035	OB05776A	RK 1M 1/4W J
ZD952	OB12619A	RD5.6JB-T1B3	R559	OB09733A	RK 220K 1/6W J	R1036	OB01857A	RK 1K 1/4W J
			R560,561	OB09693A	RK 4.7K 1/6W J	C501	OB01836A	CE 47 $\mu$ 10V
ZD964,965	OB12621A	RD6.8ES-T1B2	R562,563	OB09725A	RK 100K 1/6W J	C502	OB09372A	CE 2.2 $\mu$ 50V
			R564	OB09721A	RK 68K 1/6W J	C503	OB41917A	CC 0.1 $\mu$ 25V Z
ZD1002	OB12177A	RD15ES-T1B1	R565	OB09725A	RK 100K 1/6W J	C504	OB41914A	CC 0.01 $\mu$ 50V Z
			R566	OB09677A	RK 1K 1/6W J	C505	OB01405A	CE 1 $\mu$ 50V
			R567,568	OB09725A	RK 100K 1/6W J	C506	OB41787A	CC 0.022 $\mu$ 25V Z
D501,502	OB06398A	SID 1SS176	R569	OB09701A	RK 10K 1/6W J	C507	OB05885A	CE 100 $\mu$ 10V
D503	OB06398A	SID 1SS176	R570	OB09677A	RK 1K 1/6W J	C508	OB01405A	CE 1 $\mu$ 50V
D505,506	OB12363A	SID MA700	R571	OB09699A	RK 8.2K 1/6W J	C509	OB05681A	CML 0.01 $\mu$ 50V J
D507	OB12363A	SID MA700	R572	OB09701A	RK 10K 1/6W J	C510,511	OB41903A	CC 33P 50V J
D508	OB06398A	SID 1SS176	R573,574	OB09677A	RK 1K 1/6W J	C512	OB01405A	CE 1 $\mu$ 50V
D509	OB12363A	SID MA700		OB00346A	RK 1K 1/2W J	C513	OB41787A	CC 0.022 $\mu$ 25V Z
D510,511	OB06398A	SID 1SS176		OB01846A	RK 4.7K 1/4W J	C514	OB01405A	CE 1 $\mu$ 50V
D512,513	OB06398A	SID 1SS176				C515	OB08899A	CE 220 $\mu$ 10V
D514,515	OB06398A	SID 1SS176						



6.19. Video & Logic F.C.B. Assy

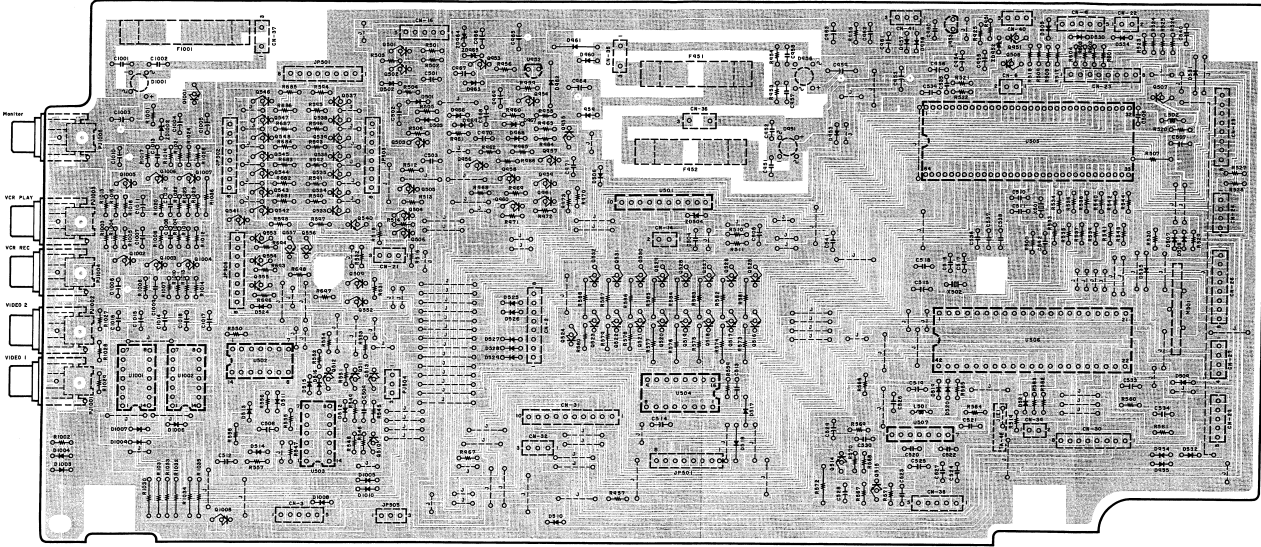

Fig. 6.19

Schematic Ref. No.	Part No.	Description	Schematic Ref. No.	Part No.	Description	Schematic Ref. No.	Part No.	Description	Schematic Ref. No.	Part No.	Description	Schematic Ref. No.	Part No.	Description
C516	0B41902A	CC 22P 50V J	C959	0B40095A	CE 1000u 25V	C1016,1017	0B01862A	CE 22u 16V	CN2	0B81765A	8P-T Post EH-8P	CN32	0B81968A	3P-T Post EH-3P
C517	0B41904A	CC 47P 50V J	C960	0B41917A	CC 0.1u 25V Z	C1018	0B01862A	CE 22u 16V						
C518	0B41787A	CC 0.022u 25V Z	C981	0B01412A	CE 10u 16V	F951	0B00386A	Fuse 1A 250V	CN3	0B81762A	5P-T Post EH-5P	CN35	0B81760A	3P-T Post EH-3P
C519	0B01408A	CE 1u 50V	C982	0B41917A	CC 0.1u 25V Z									
C520	0B41906A	CC 39P 50V J	C983	0B01400A	CE 100u 16V									
C521	0B41914A	CC 0.01u 50V Z	C984	0B40094A	CE 470u 25V	F952	0B00386A	Fuse 1A 250V	CN6	0B81759A	2P-T Post EH-2P	CN36	0B81968A	3P-T Post EH-3P
C522	0B41915A	CC 2500P 50V K	C985	0B40123A	CE 470u 50V									
C523	0B41787A	CC 0.022u 25V Z	C986	0B40100A	CE 10u 35V									
C524	0B41909A	CC 100P 50V J	C987	0B01405A	CE 1u 50V									
C525	0B01403A	CE 47u 16V	C988	0B01409A	CE 100u 16V									
C526,527	0B41787A	CC 0.022u 25V Z	C989	0B01408A	CE 1u 50V	F1001	0B00385A	Fuse 0.5A 250V	CN14	0B81967A	2P-T Post EH-2P	CN38	0B81762A	5P-T Post EH-5P
C528	0B40103A	CE 47u 35V	C990	0B01863A	CE 3.3u 50V									
C529	0B09567A	CE 0.33u 50V (LN)	C970	0B41304A	CE 0.33u 50V J									
C530	0B01780A	CML 0.1u 50V J	C971	0B41304A	CML 0.33u 50V J									
C533	0B01405A	CE 1u 50V	C1003	0B40423A	CE 470u 16V	FJ501	0B83399B	Flat Wire SP 260	CN22	0B81966A	2P-T Post EH-2P			
C534	0B40025A	CE 0.47u 50V	C1004	0B40079A	CE 220u 16V	FJ502	0B83399B	Flat Wire SP 250						
C535,536	0B41787A	CC 0.022u 25V Z	C1005	0B01409A	CE 100u 16V	FJ503	0B83400B	Flat Wire SP 320	CN23	0B81959A	8P Connector			
C537,538	0B41787A	CC 0.022u 25V Z	C1006	0B40082A	CE 1000u 16V	FJ504	0B83394B	Flat Wire SP 320	CN24	0B81958A	4P Connector			
C539,540	0B41787A	CC 0.022u 25V Z	C1007	0B01400A	CE 100u 16V	FJ505	0B83395B	Flat Wire SP 400	CN25,26	0B81958A	8P Connector			
C541,542	0B41787A	CC 0.022u 25V Z	C1008	0B41905A	CC 5P 50V C	FJ506	0B83399B	Flat Wire SP 250	CN27	0B81761A	4P-T Post EH-4P			
C543,544	0B41915A	CC 0.1u 50V Z	C1009	0B41310A	CC 380P 50V J	X1001	0B81947A	1P Pin Jack						
C953	0B40082A	CE 1000u 16V	C1010	0B40082A	CE 1000u 16V	1002			CN29	0B81956A	8P Connector			
C954	0B01400A	CE 100u 16V	C1011	0B01400A	CE 100u 16V	X1003			CN30	0B81956A	8P Connector			
C955	0B01405A	CE 1u 50V	C1012	0B41905A	CC 5P 50V C	1004			CN31	0B81767A	10P-T Post EH-10P			
C956	0B09568A	CE 100u 10V	C1013	0B41310A	CC 380P 50V J	FJ1005	0B81947A	1P Pin Jack						
C957,958	0B41915A	CC 0.1u 50V Z	C1014,1015	0B01862A	CE 22u 16V									

6.20. Main P.C.B. Assy

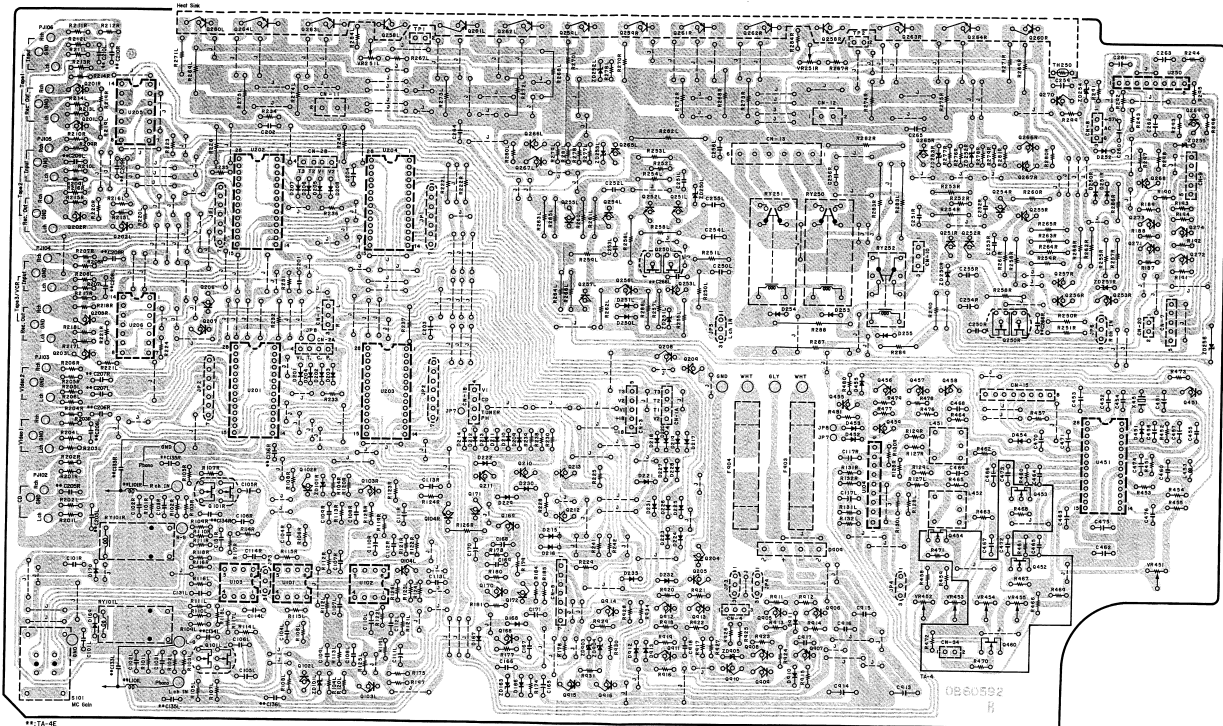

Fig. 6.20



7. SCHEMATIC DIAGRAMS

7.1. IC Block Diagrams

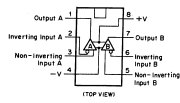

Fig. 7.1.1 Operational Amp. IC NJM4558D, NJM072DE, NJM5532DD

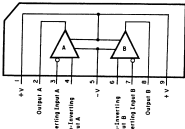

Fig. 7.1.2 Operational Amp. IC NJM4558S, NJM5532SD

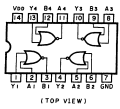

Fig. 7.1.3 NOR Gate C-MOS IC  $\mu$ PD4001BC

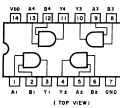

Fig. 7.1.4 AND Gate C-MOS IC  $\mu$ PD4081BC

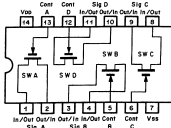

Fig. 7.1.5 Bilateral Switch IC TC4066BP, LC4966

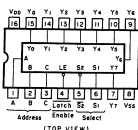

Fig. 7.1.6 3-to-8 Line Decoder IC  $\mu$ PD74HC237

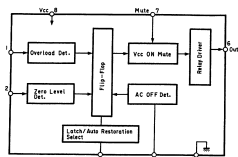

Fig. 7.1.8 Power Amp. Protector IC  $\mu$ PC1287H

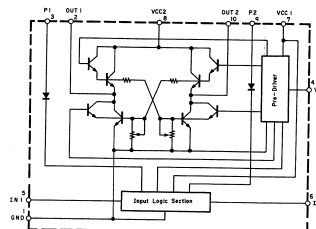

Fig. 7.1.10 Motor Control IC LB1645N

INPUT	OUTPUT	OPERATION
ZN1	OUT1	Braking
ZN2	OUT2	Forward (Forward)
0	0	Reverse (Reverse)
1	1	Braking

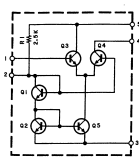

Fig. 7.1.7 FM IF Amp. IC TA7060AP

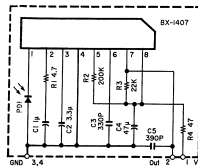

Fig. 7.1.9 Remote Control Receiver IC BX-1407

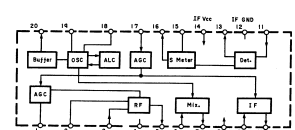

Fig. 7.1.11 AM Tuner IC LA1247

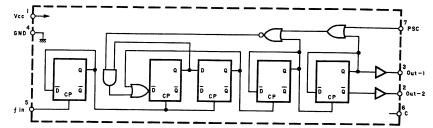

Fig. 7.1.12 ECL Prescaler (FM) IC TD6104P

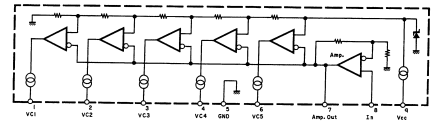

Fig. 7.1.13 Signal Meter Driver IC LB1413N

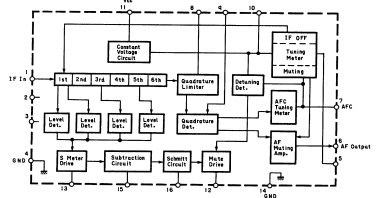

Fig. 7.1.14 FM IF Amp. & Detector IC LA1235

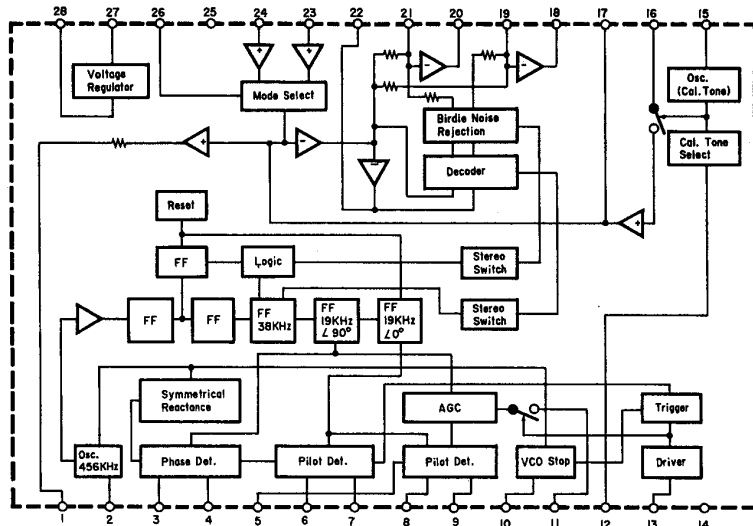

Fig. 7.1.15 PLL FM MPX Demodulator IC LA3450

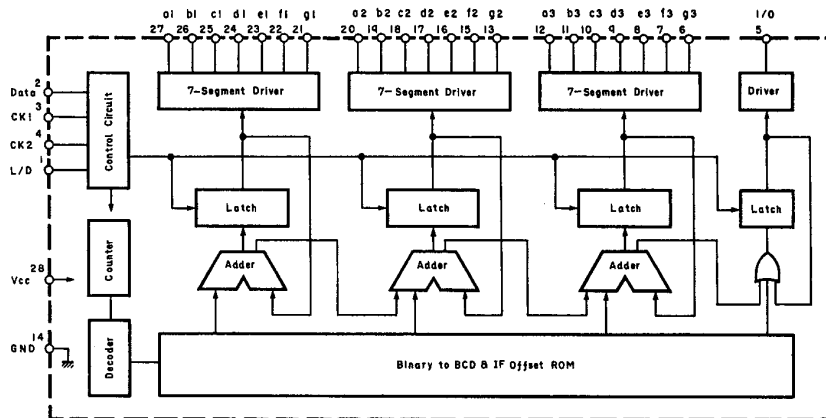

Fig. 7.1.16 Display Driver IC TD6301AN

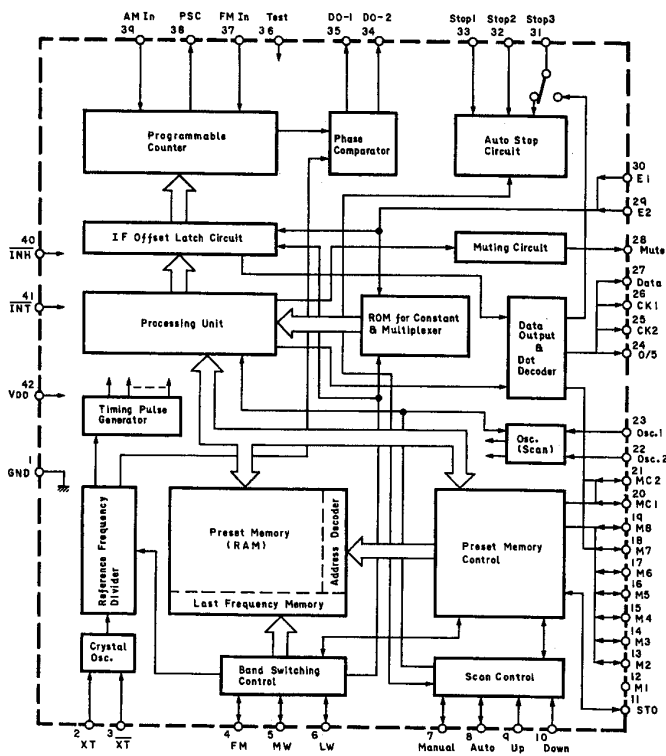

Fig. 7.1.17 PLL Synthesizer IC TC9147BP

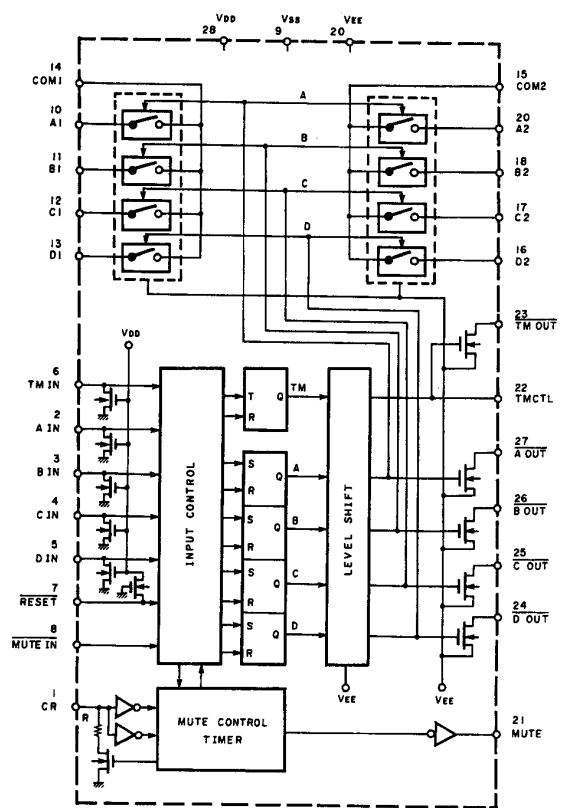

Fig. 7.1.18 Analog Function Switch LC7816

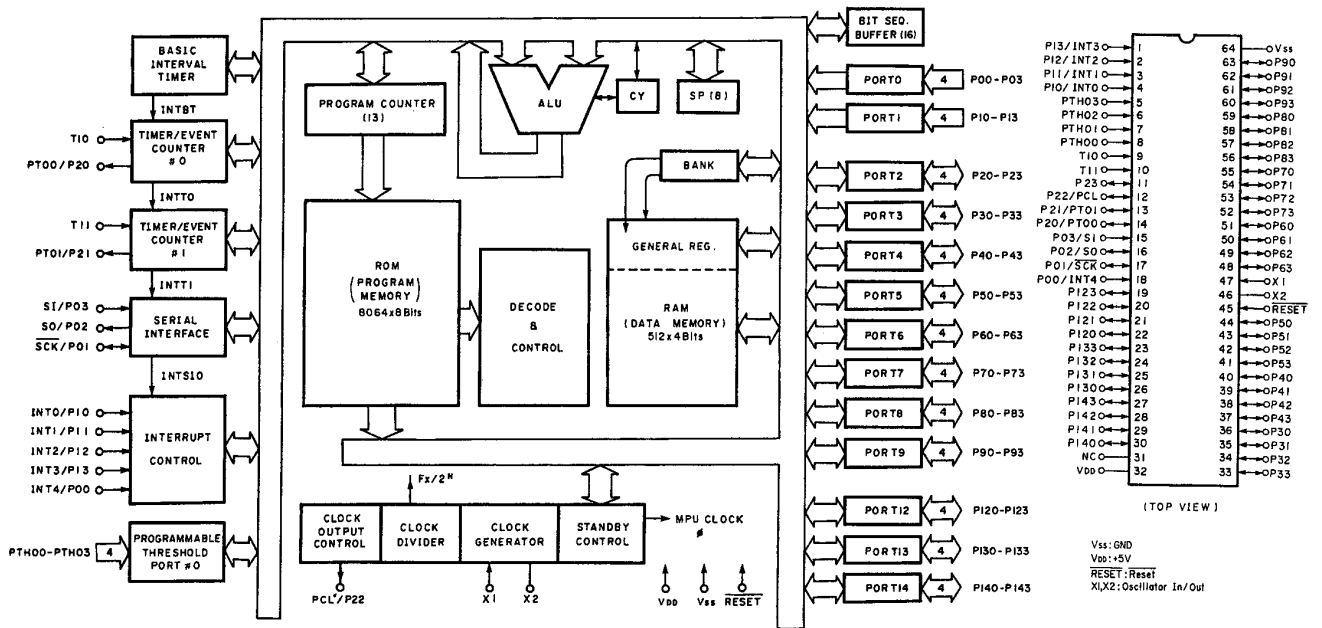

Fig. 7.1.19 MPU μPD75104CW



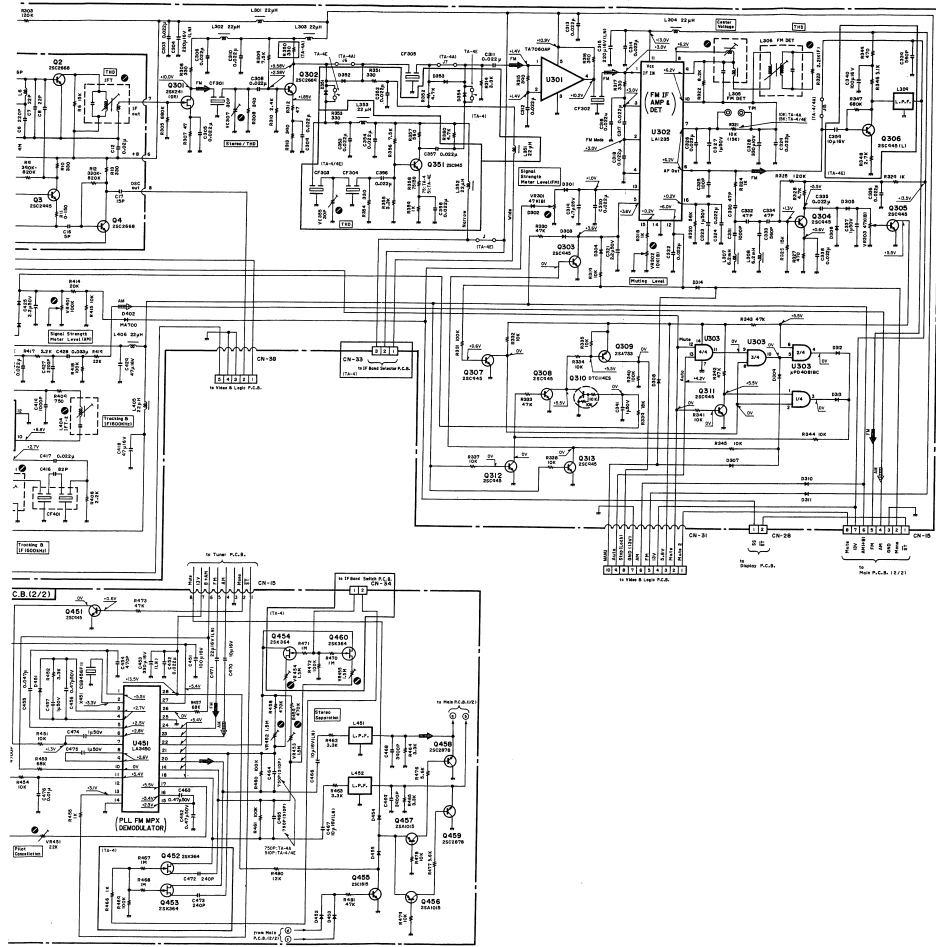
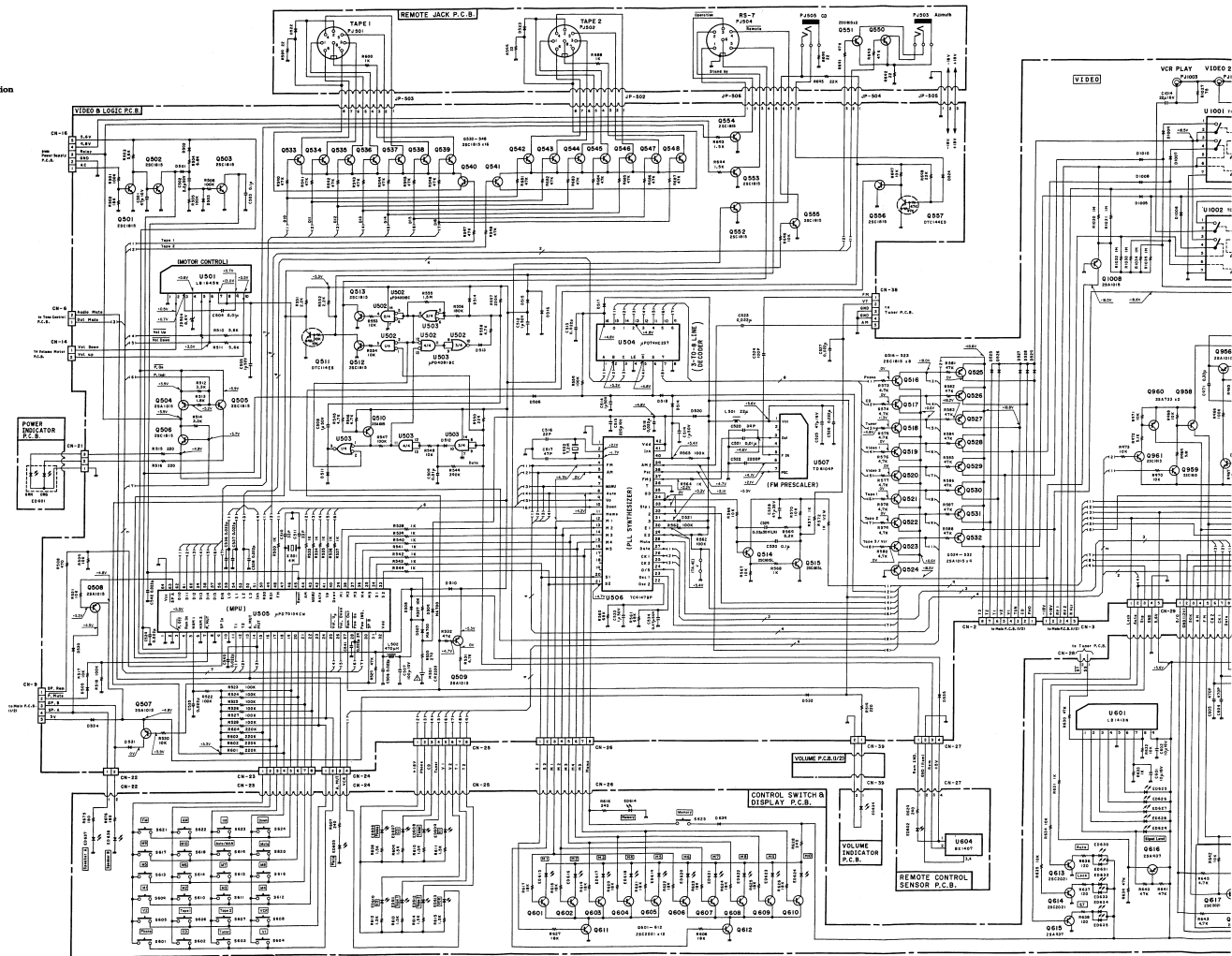

Fig. 7.2.1

- Notes:
1. Diode is 1SS53, 1S1555 or 1SS176 unless otherwise specified.
  2. 2SA733, 2SA608SP, 2SA1048 and 2SA1175 are interchangeable with each other.
  3. 2SC945, 2SC586SP, 2SC2458 and 2SC2785 are interchangeable with each other.
  4. Voltage measuring conditions
    - With no input signal applied to the input terminals.
    - With no load connected to the speaker terminals.



7.2.2. Video and Control Section



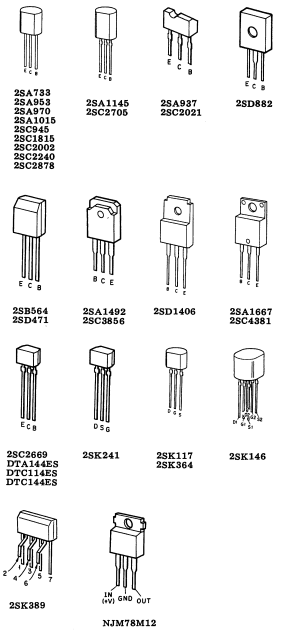
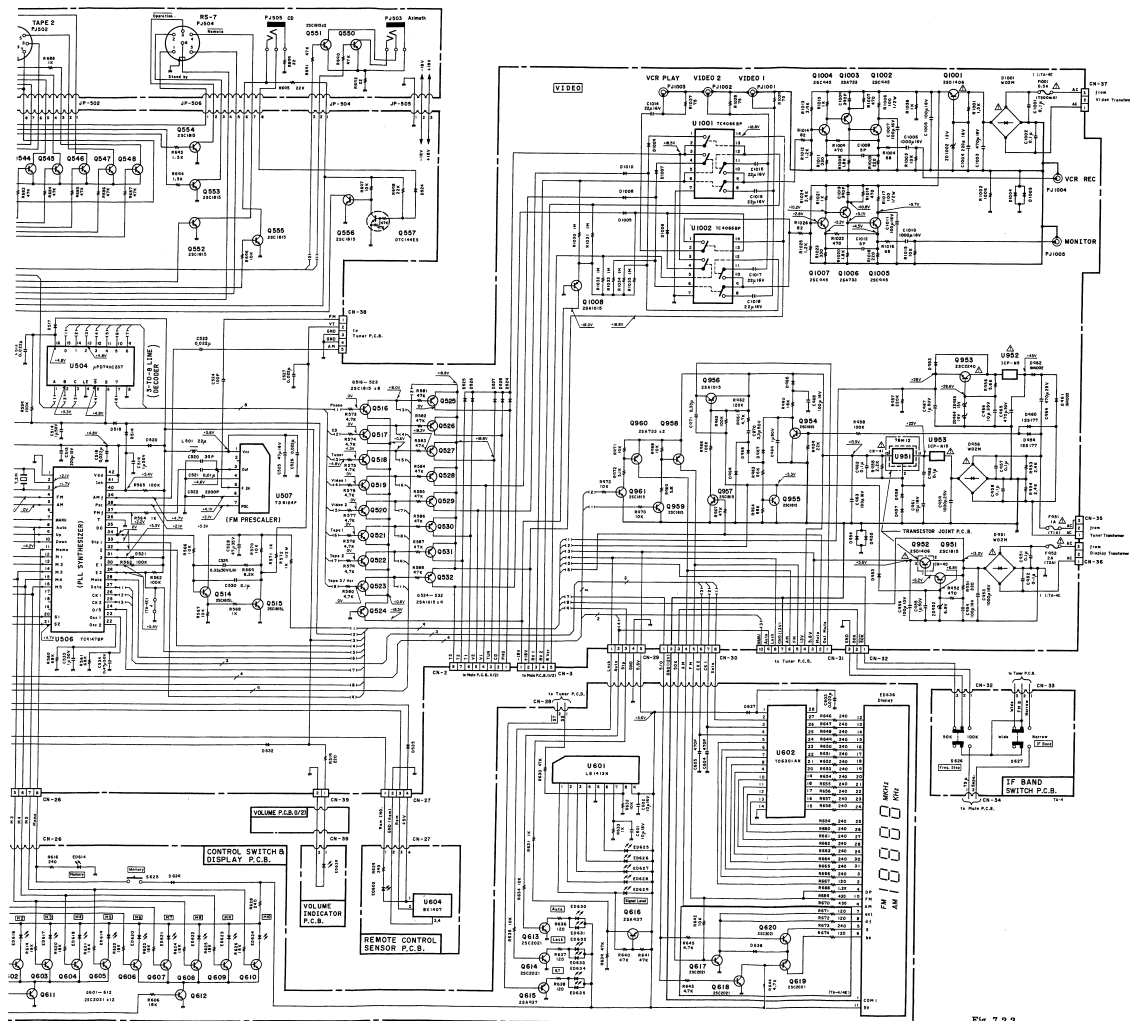

Notes:

1. Diode is 1SS53, 1S1555 or 1SS176 unless otherwise specified.
2. 2SA733, 2SA608SP, 2SA1048 and 2SA1175 are interchangeable with each other.
3. 2SC945, 2SC5365P, 2SC2458 and 2SC2785 are interchangeable with each other.
4. Parts marked with \*\* indicate those for TA-4E.
5. Voltage measuring conditions
  - With no input signal applied to the input terminals.
  - With no load connected to the speaker terminals.

Fig. 7.2.2

7.2.3. Amplifier Section

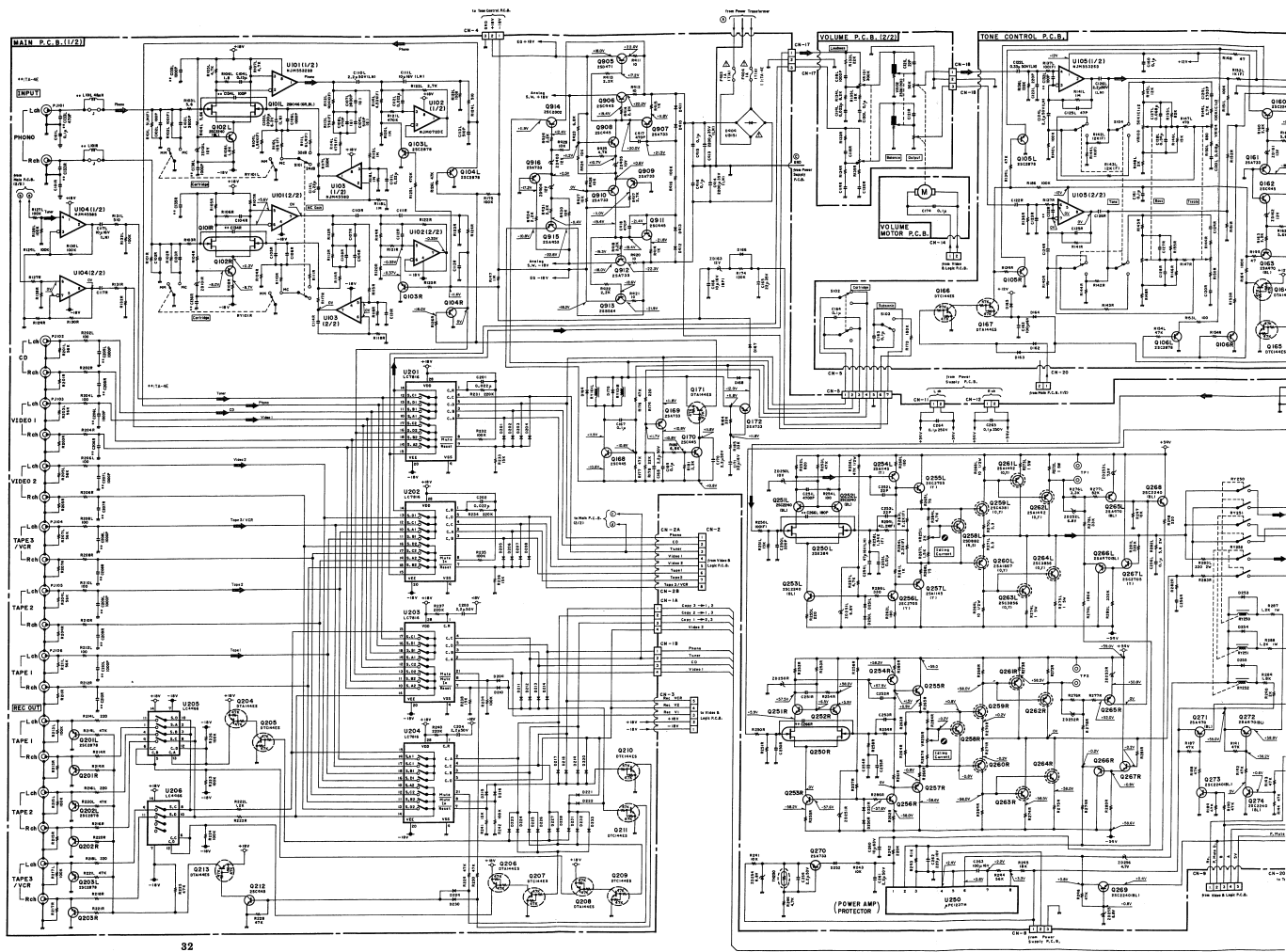

Fig. 7.2.3

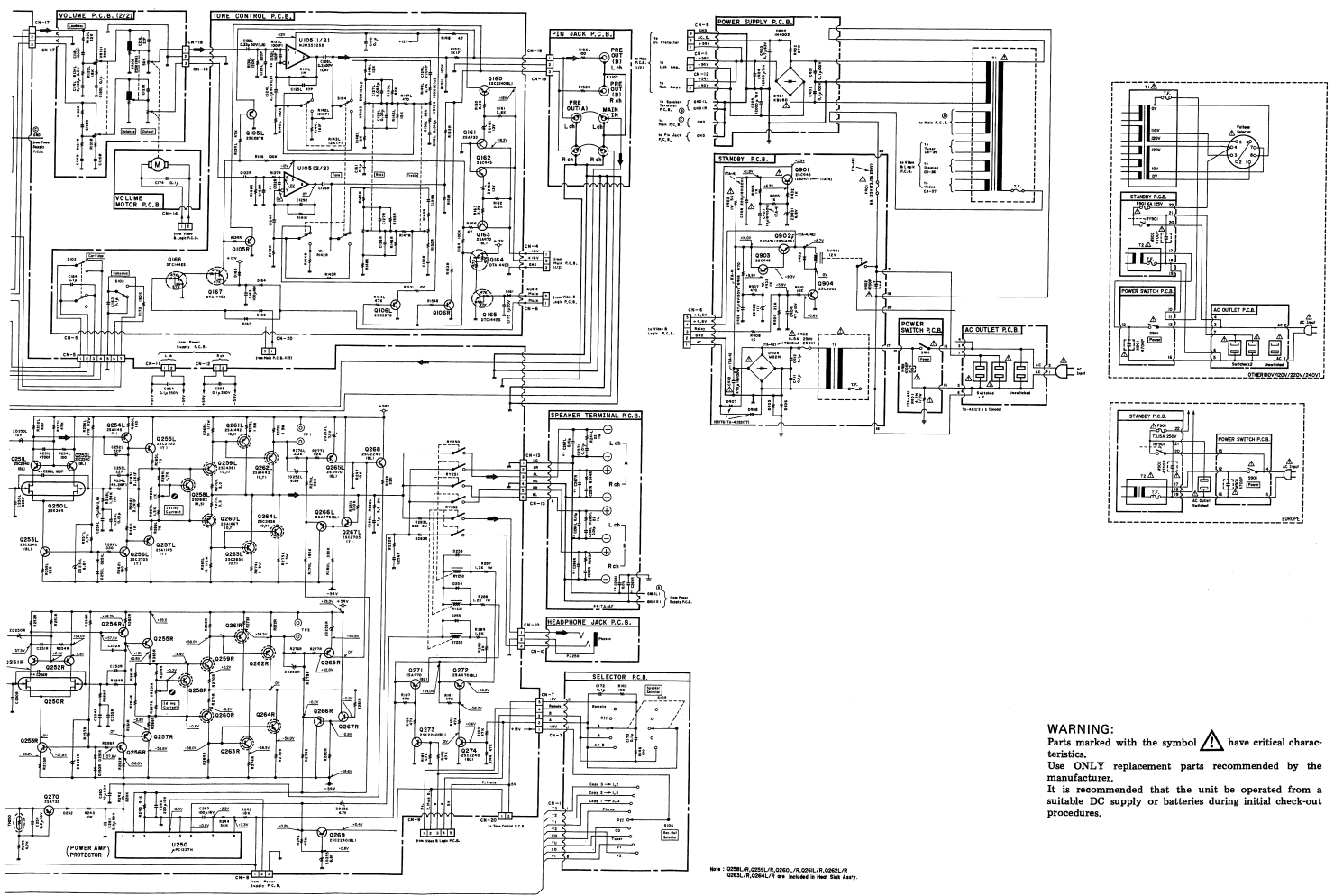



Fig. 7.2.3

**WARNING:**  
 Parts marked with the symbol  have critical characteristics.  
 Use **ONLY** replacement parts recommended by the manufacturer.  
 It is recommended that the unit be operated from a suitable DC supply or batteries during initial check-out procedures.

NOTE: Q264L/R, Q265L/R, Q266L/R, Q267L/R, Q268L/R, Q269L/R, Q270L/R are included in the 500 Assy.

8. WIRING DIAGRAM

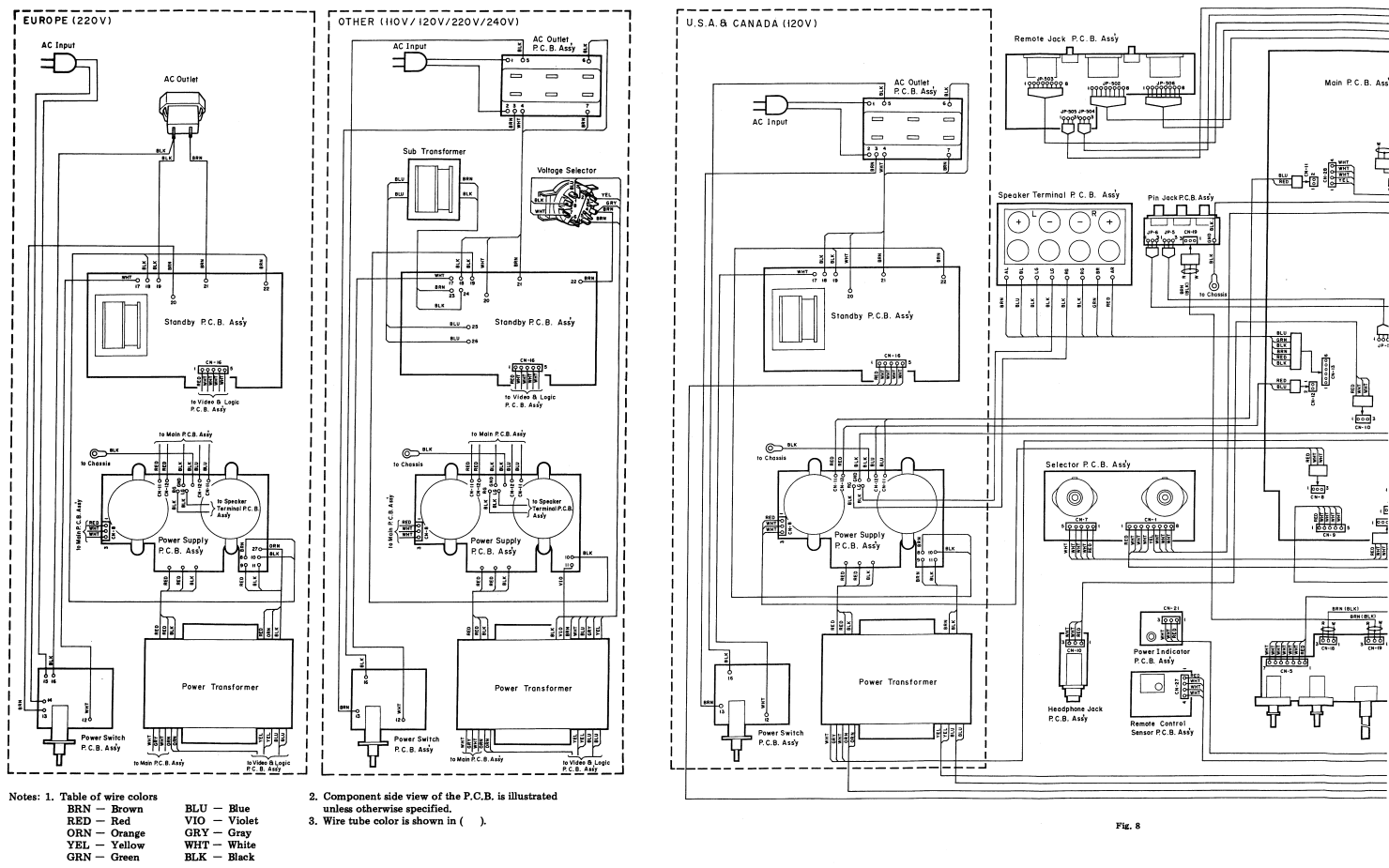

Fig. 8

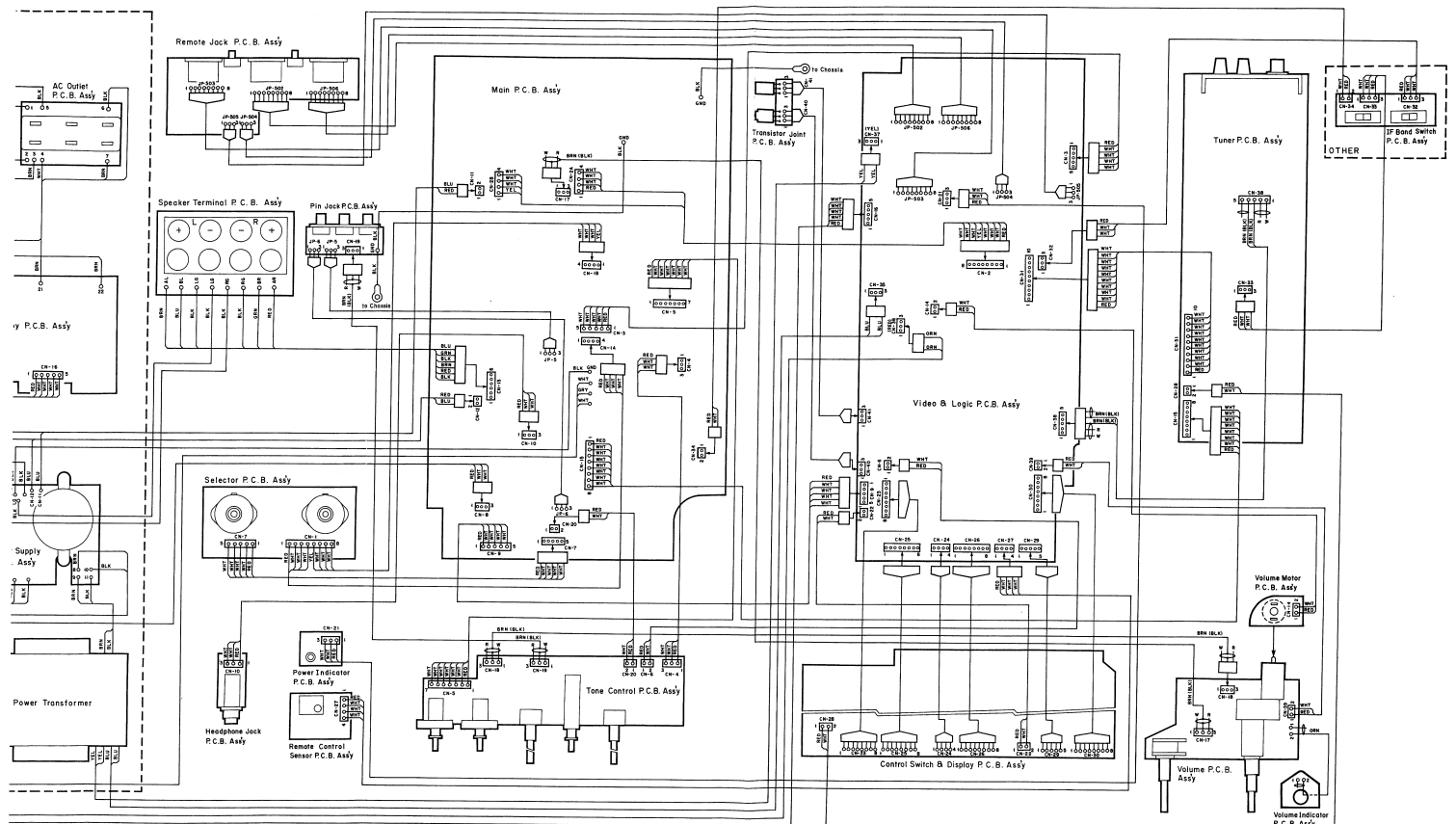

Fig. 8

9. BLOCK DIAGRAMS

9.1. Tuner Section

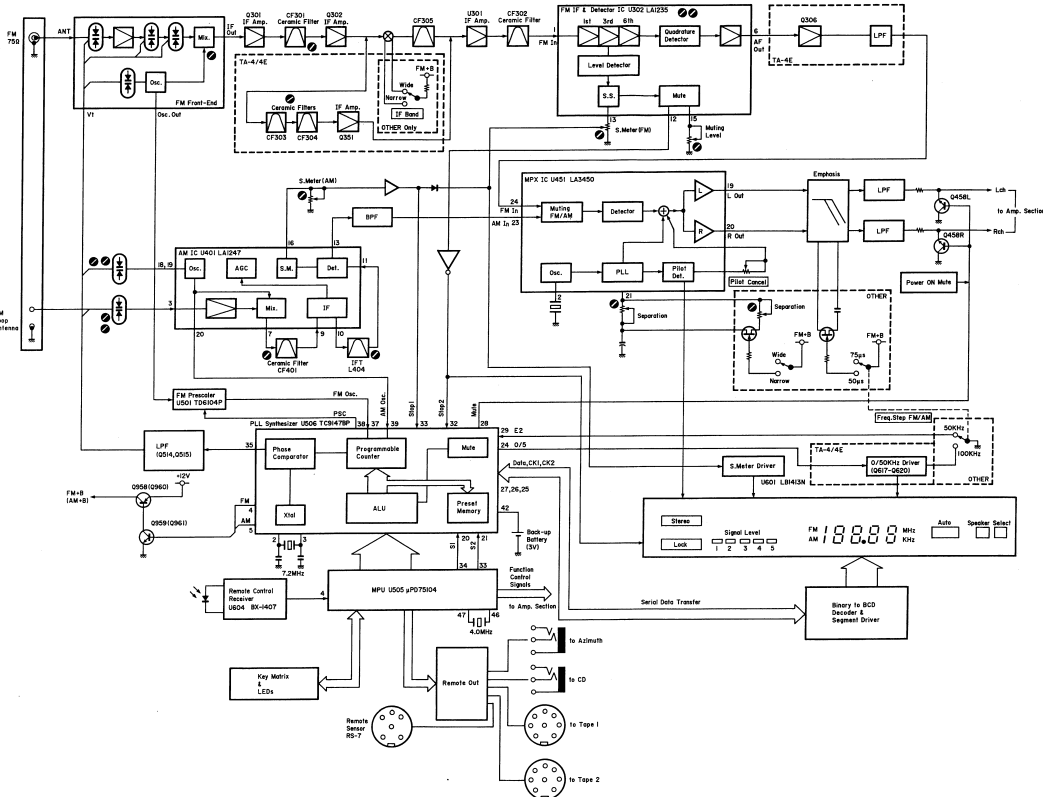

Fig. 9.1

9.2. Amplifier Section

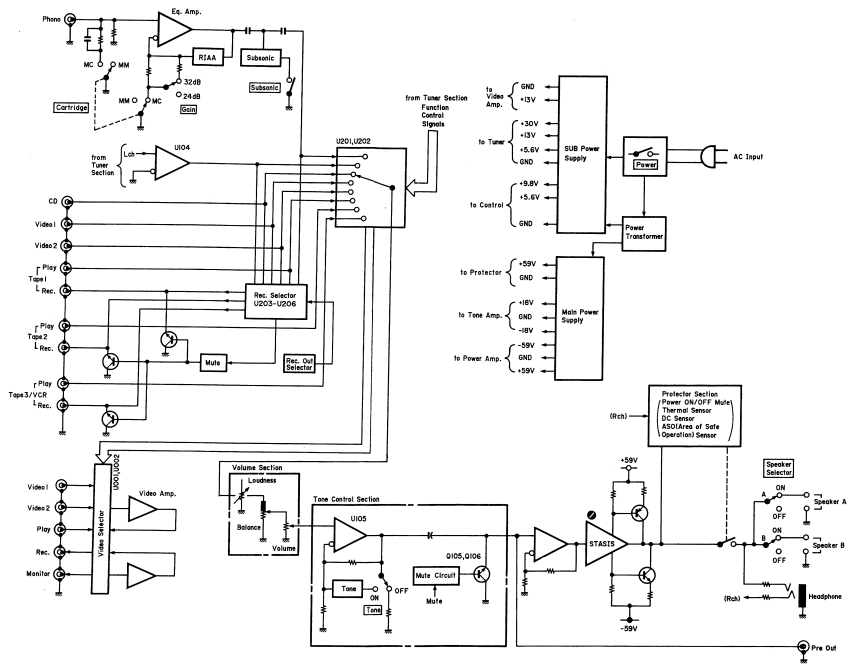

Fig. 9.2



## 10. SPECIFICATIONS

### Power Amplifier Section

Note: Unless noted otherwise, specifications are in accordance with IHF-A-202 measured from any high-level input (CD/VIDEO/TAPE) to the speaker output.

Continuous Average Output Power	100 watts per channel into 8 ohms, both channels driven, 20–20,000 Hz, at no greater than 0.1% THD
Dynamic Output Power	132 watts per channel into 8 ohms 167 watts per channel into 4 ohms
Power Bandwidth	5–60,000 Hz 5–30,000 Hz (TA-4E)
Frequency Response	20–20,000 Hz; +0, –0.5 dB 20–20,000 Hz; +0, –1 dB (TA-4E) 5–85,000 Hz; +0, –3 dB 5–45,000 Hz; +0, –3 dB (TA-4E)
Signal to Noise Ratio (A-WTD, Input Shorted)	Better than 100 dB re Rated Power Better than 83 dB (IHF-A-202)
Total Harmonic Distortion (8 ohms, Rated Power, 20 Hz–20 kHz)	Less than 0.1%
Headphone Rated Output (40 ohms)	234 mW
Output Current Capability	28 A peak per channel

### Preamplifier Section

Note: Unless noted otherwise, specifications are in accordance with IHF-A-202. Except for Sensitivity, S/N, Tone Control and Loudness characteristics (which are measured to the speaker outputs), measurements are made from the specified input to Rec. Out.

Sensitivity (for rated output)	
Phono MC	60/160 $\mu$ V (Gain: 32/24 dB)
Phono MM	2.5 mV
CD/Tape/Video	150 mV
Main In	1.0 V
Sensitivity (for 1-watt output, IHF-A-202)	
Phono MC	6.0/16 $\mu$ V (Gain: 32/24 dB)
Phono MM	0.25 mV
CD/Tape/Video	15 mV
Main In	100 mV
Input Impedance	
Phono MC	100 ohms
Phono MM	47 kohms
CD/Tape/Video	20 kohms
Main In	15 kohms
Maximum Input Level (1 kHz)	
Phono MC	4.0/10 mV (Gain: 32/24 dB)
Phono MM	180 mV
Pre Output Level/Impedance	1.0 V/1 kohms
Record Output Level/Impedance	150 mV/1.5 kohms
Total Harmonic Distortion (1 kHz, to Rec. Out, at 1 V)	
Phono MC	Less than 0.007% (either gain)
Phono MM	Less than 0.005%
RIAA Deviation	
Phono MC	30–20,000 Hz $\pm$ 0.5 dB
Phono MM	30–20,000 Hz $\pm$ 0.5 dB
Signal to Noise Ratio (to speaker output, IHF-A-202)	
Phono MC	Better than 70 dB (either gain) Better than 68 dB (either gain) (TA-4E)
Phono MM	Better than 78 dB Better than 76 dB (TA-4E)

**Tone Controls**

Bass . . . . . 20 Hz,  $\pm 10$  dB  
Treble . . . . . 20 kHz,  $\pm 10$  dB  
Variable Loudness . . . . . 20 Hz, +20 dB; 20 kHz, +6 dB  
(re maximum attenuation:  
-40 dB at 1 kHz)  
Subsonic Filter (Phono only) . . Cutoff Frequency 20 Hz, -12 dB/octave

**Tuner Section**

(1) TA-4 (Other) (See Note) & TA-4A

Note: Selector switch settings for Other Model

Frequency Step FM/AM: 100 kHz/10 kHz, De-emphasis: 75  $\mu$ s, IF Band: Wide

**[FM Section]**

Note: All RF levels in microvolts given re 300-ohm antenna input.

Modulation: Mono 100%, Stereo Pilot 9%, Stereo Audio Signal 91%.

All measurements made at Rec. Out Jack.

Frequency Range . . . . . 87.5-108.0 MHz in 100 kHz steps  
IHF Usable Sensitivity . . . . . 11.0 dBf/1.9  $\mu$ V  
(Mono)  
50-dB Quieting Sensitivity  
Mono . . . . . 14.7 dBf/3.0  $\mu$ V  
Stereo . . . . . 37.5 dBf/41.1  $\mu$ V  
Signal to Noise Ratio at 65 dBf  
Mono . . . . . Better than 82 dB  
Stereo . . . . . Better than 75 dB  
Muting Threshold . . . . . 30 dBf/17.3  $\mu$ V  
Frequency Response . . . . . 20-15,000 Hz  $\pm 1$  dB  
Total Harmonic Distortion (1 kHz)  
Mono . . . . . Less than 0.07%  
Stereo . . . . . Less than 0.07%  
Capture Ratio . . . . . 2.0 dB  
Alternate Channel Selectivity . . 65 dB ( $\pm 400$  kHz)  
Stereo Separation at 1 kHz . . . . Better than 50 dB  
Spurious Response Rejection . . . Better than 90 dB  
Image Rejection . . . . . Better than 75 dB  
IF Rejection . . . . . Better than 80 dB  
AM Suppression . . . . . Better than 60 dB

**[AM Section]**

Note: Modulation - 400 Hz, 30%

Frequency Range . . . . . 520-1,710 kHz in 10 kHz steps  
Sensitivity . . . . . 53 dB $\mu$ /m  
Signal to Noise Ratio at 90 . . . . Better than 52 dB  
dB $\mu$ /m  
Total Harmonic Distortion . . . . Less than 0.5%  
at 90 dB $\mu$ /m  
Selectivity . . . . . Better than 20 dB ( $\pm 10$  kHz)

**(2) TA-4 (Other) (See Note) & TA-4E**

Note: Selector switch settings for Other Model

Frequency Step FM/AM: 50 kHz/9 kHz, De-emphasis: 50  $\mu$ s, IF Band: Narrow

**[FM Section]**

Note: All RF levels in microvolts given re 300-ohm antenna input.

Modulation: Mono 60%, Stereo Pilot 9%, Stereo Audio Signal 51%.

All measurements made at Rec. Out Jack.

Frequency Range . . . . .	87.50—108.00 MHz in 50 kHz steps
IHF Usable Sensitivity (Mono) . .	11.0 dBf/1.9 $\mu$ V
50-dB Quieting Sensitivity	
Mono . . . . .	23.0 dBf/7.7 $\mu$ V
Stereo . . . . .	44.0 dBf/86.8 $\mu$ V
Signal to Noise Ratio at 65 dBf	
Mono . . . . .	Better than 72 dB (TA-4E)/78 dB (TA-4 (Other))
Stereo . . . . .	Better than 67 dB (TA-4E)/68 dB (TA-4 (Other))
Muting Threshold . . . . .	30 dBf/17.3 $\mu$ V
Frequency Response . . . . .	20—15,000 Hz $\pm$ 1 dB
Total Harmonic Distortion (1 kHz)	
Mono . . . . .	Less than 0.20%
Stereo . . . . .	Less than 0.25%
Capture Ratio . . . . .	2.0 dB
Alternate Channel Selectivity . .	70 dB ( $\pm$ 300 kHz)
Stereo Separation at 1 kHz . . .	Better than 40 dB
Spurious Response Rejection . .	Better than 90 dB
Image Rejection . . . . .	Better than 75 dB
IF Rejection . . . . .	Better than 80 dB
AM Suppression . . . . .	Better than 60 dB

**[AM Section]**

Note: Modulation — 400 Hz, 30%

Frequency Range . . . . .	522—1,611 kHz in 9 kHz steps
Sensitivity . . . . .	53 dB $\mu$ /m
Signal to Noise Ratio at 90 . . .	Better than 52 dB
dB $\mu$ /m	
Total Harmonic Distortion . . . .	Less than 0.5%
at 90 dB $\mu$ /m	
Selectivity . . . . .	Better than 20 dB ( $\pm$ 9 kHz)

**General**

Power Source . . . . .	120, 220, 240 or 110/120/220/240 V AC, 50/60 Hz (According to country of sale)
Power Consumption . . . . .	425 watts max.
Convenience Outlets . . . . .	Switched (2 pcs.) + Unswitched (1 pce.) (TA-4 (Other) & TA-4A) Switched (1 pce.) (TA-4E)
Dimensions . . . . .	430 (W) x 125 (H) x 370 (D) mm 16-15/16 (W) x 4-15/16 (H) x 14-9/16 (D) inches
Approximate Weight . . . . .	15.0 kg, 33 lbs. 1 oz.

**Remote Control Unit (RM-4TA)**

Principle . . . . .	Infrared Pulse System
Power Supply . . . . .	3 V DC (1.5 V x 2)
Dimensions . . . . .	64 (W) x 18 (H) x 176 (D) mm 2-1/2 (W) x 11/16 (H) x 6-15/16 (D) inches
Approximate Weight . . . . .	140 g, 5 oz. (including batteries)

- Specifications and design are subject to change for further improvement without notice.
- STASIS manufactured under license from Threshold Corporation.
- STASIS is a trademark of Threshold Corporation.