

NEC Authentic series

MODEL A210ME
A225ME

STEREO AMPLIFIER SERVICE MANUAL

SER. No. 4064



Better Service
Better Reputation
Better Profit

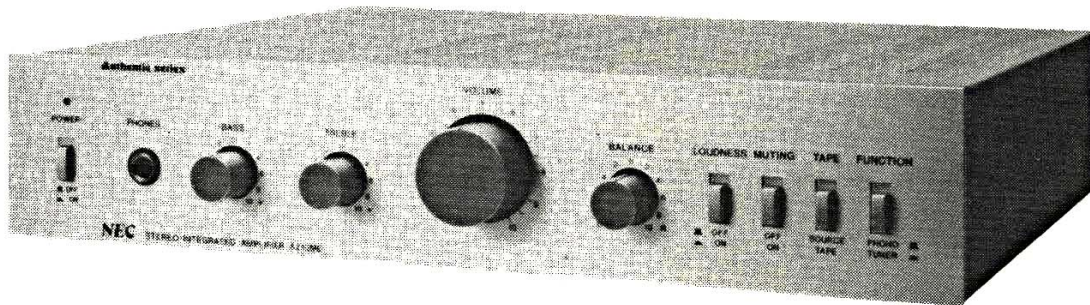

Specifications

Continuous Output Power 20 Watts x 2 at
Both channels driven at 0.5% THD
20Hz-20kHz, 8 ohms load

Total Harmonic Distortion
Rated Power at 20Hz-20kHz 0.5%
1/2 Power at 20Hz-20kHz 0.3%
1W Power at 20Hz-20kHz 0.3%

Intermodulation Distortion
Rated Power at 60Hz:7kHz=4:1 0.5%

Power Bandwidth 15Hz-30kHz
IHF both channels driven
at 8 ohms load

Frequency Response 20Hz-40kHz±1dB
TUNER/TAPE-1

Damping Factor at 20Hz-20kHz 30

Recommended Speaker Impedance
A & B Independent Operation 8 ohms-16 ohms
A + B Simultaneous Operation 8 ohms-16 ohms
Headphone 4 ohms-16 ohms

Phono Overload Capability 180mV

Phono Equalization Accuracy 30Hz-15kHz
±0.5dB

Input Sensitivity/Impedance
PHONO 2.5mV/47kohms
TUNER/TAPE-1 150mV/47kohms

Recording Output Level 140mV

Signal to Noise Ratio
PHONO 73dB (IHF-A)
TUNER/TAPE-1 93dB (IHF-A)

Tone Control Response
Bass at 100Hz ±8dB
Treble at 10kHz ±9dB

Loudness Control Response
at 100Hz +8dB
at 10kHz +3dB

Power Requirements AC 115V/230V,
50/60Hz

Dimensions 300(W) x 58(H) x
230(D) mm

Weight Approximately 4.1 kgs.

Nippon Electric Co., Ltd.

TOKYO, JAPAN

DISASSEMBLY

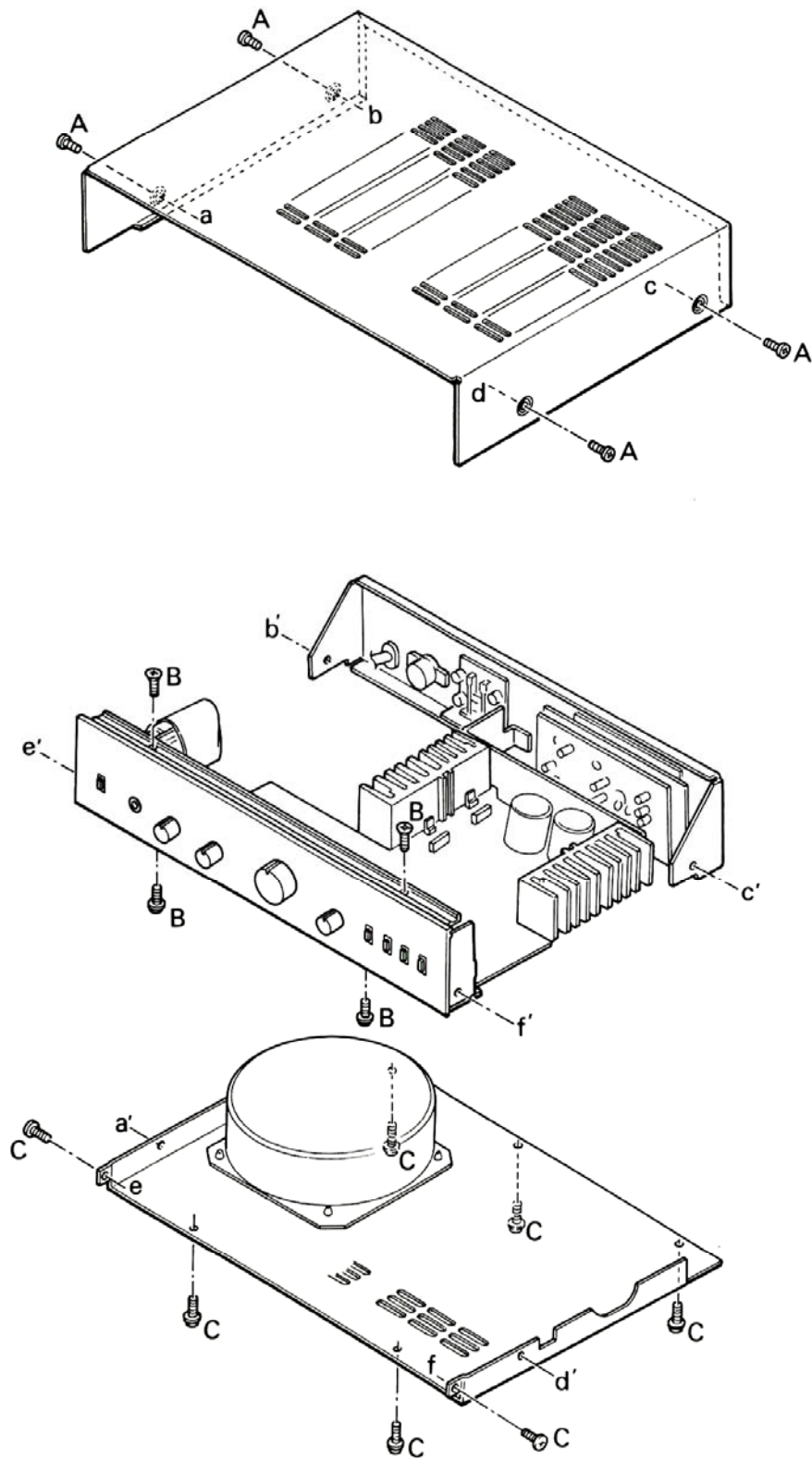

EXTERNAL VIEW

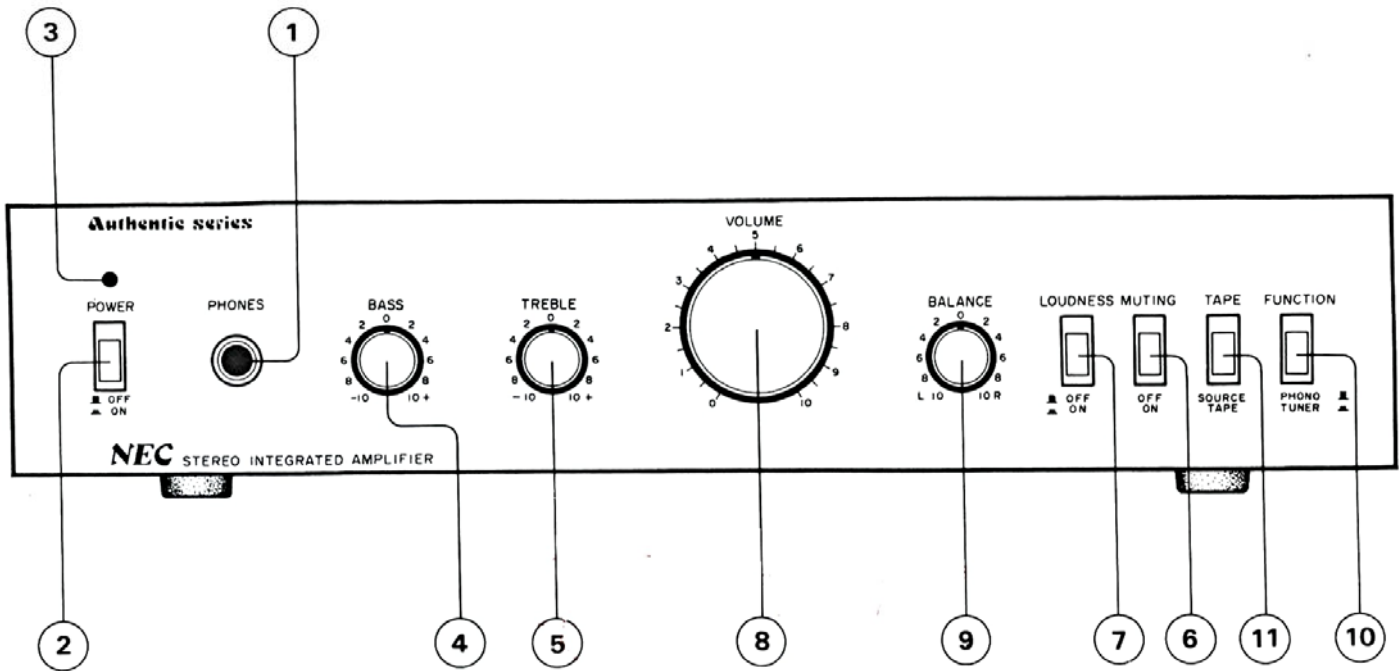

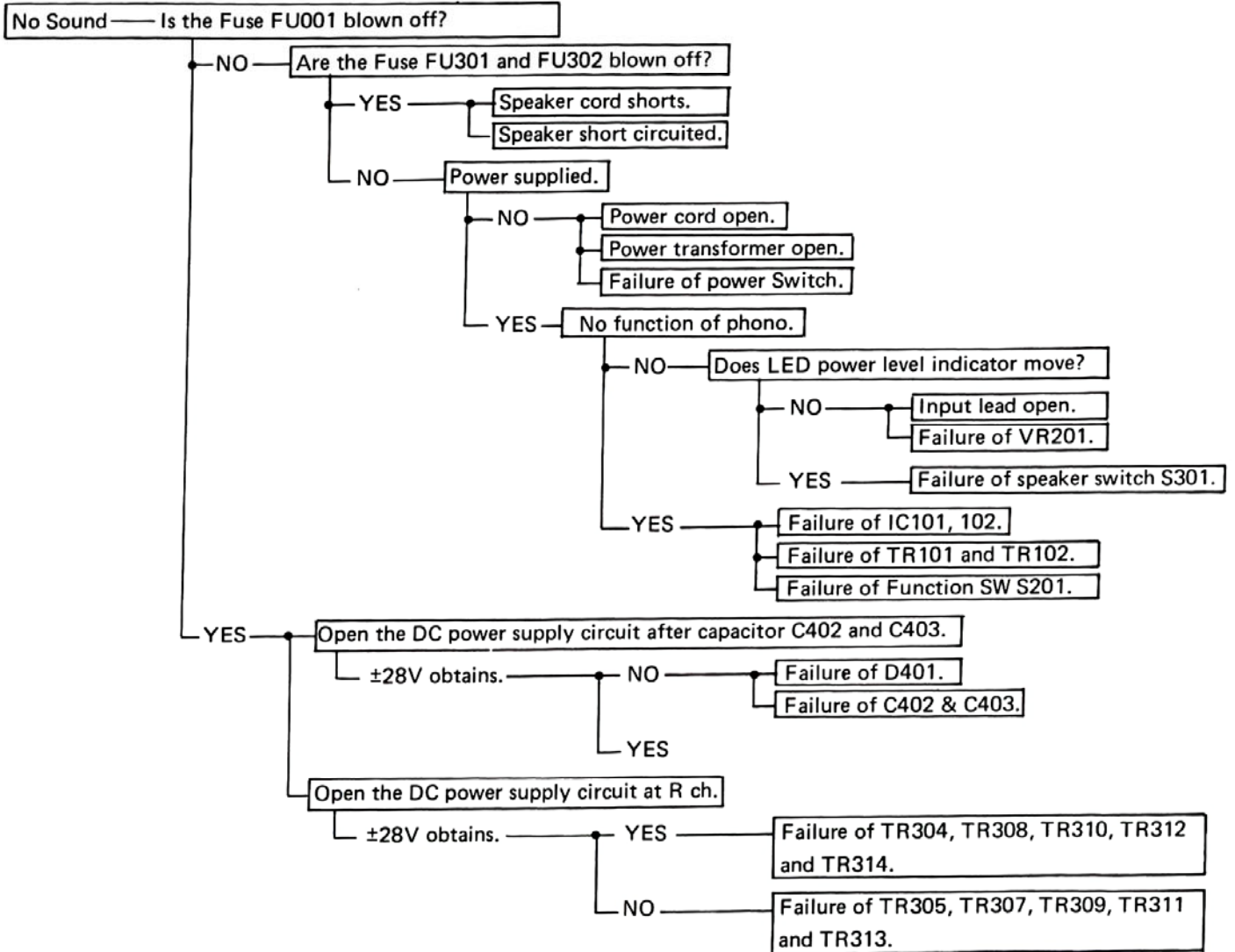

- | | |
|--------------------|---------------------|
| 1. HEADPHONE JACK | 7. LOUDNESS SWITCH |
| 2. POWER SWITCH | 8. VOLUME CONTROL |
| 3. POWER INDICATOR | 9. BALANCE CONTROL |
| 4. BASS CONTROL | 10. FUNCTION SWITCH |
| 5. TREBLE CONTROL | 11. TAPE SWITCH |
| 6. MUTING SWITCH | |

TROUBLESHOOTING

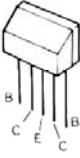

TRANSISTOR & IC LEAD IDENTIFICATION

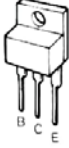
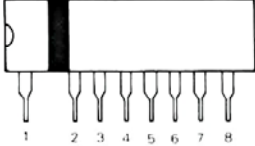
<p>TR301, 302</p>	<p>2SA798 (G)</p>	
<p>TR102</p> <p>TR101 303, 304 315, 316 401</p> <p>TR201, 202</p> <p>TR309, 310</p> <p>TR305, 306 402</p> <p>TR307, 308 601</p>	<p>2SA733 (Q, R)</p> <p>2SC945 (Q, R)</p> <p>2SA952 (K, L)</p> <p>2SB647 (C)</p> <p>2SC1845 (E, F)</p> <p>2SD667 (C)</p>	
<p>TR311, 312</p> <p>TR313, 314</p>	<p>2SC1827 (O, Y)</p> <p>2SA769 (O, Y)</p>	
<p>IC101, 102</p>	<p>HA1457W</p>	 <p style="text-align: center;">SIDE VIEW</p>

BLOCK DIAGRAM

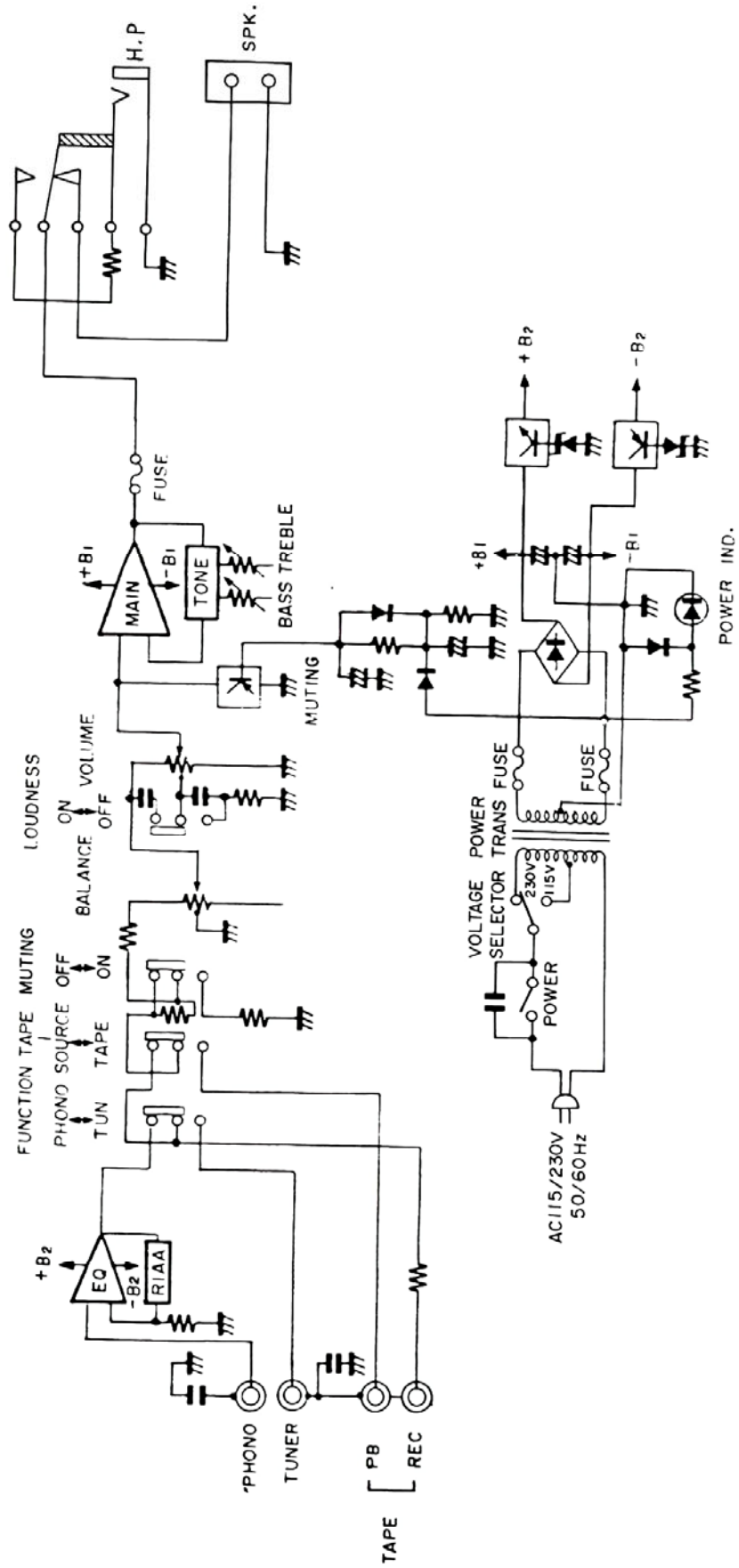

SCHEMATIC DIAGRAM

FUNCTION TAPE I MUTING CONTROL BALANCE VOLUME TR201,2 25A952
 S201 S202 S203 S204 VR202 VR201
 TUN TAPE I TAPE I 500K(W) 150K(B)
 PHONO SOURCE OFF OFF

TR301,2 28A798 TR311,12 25C1827
 TR303,4,15,16 28C945 TR313,14 25A769
 TR305,6 28C1845 D301,2 1S2473
 TR307,8 25D667 D305 RD13,18
 TR309,10 28B647

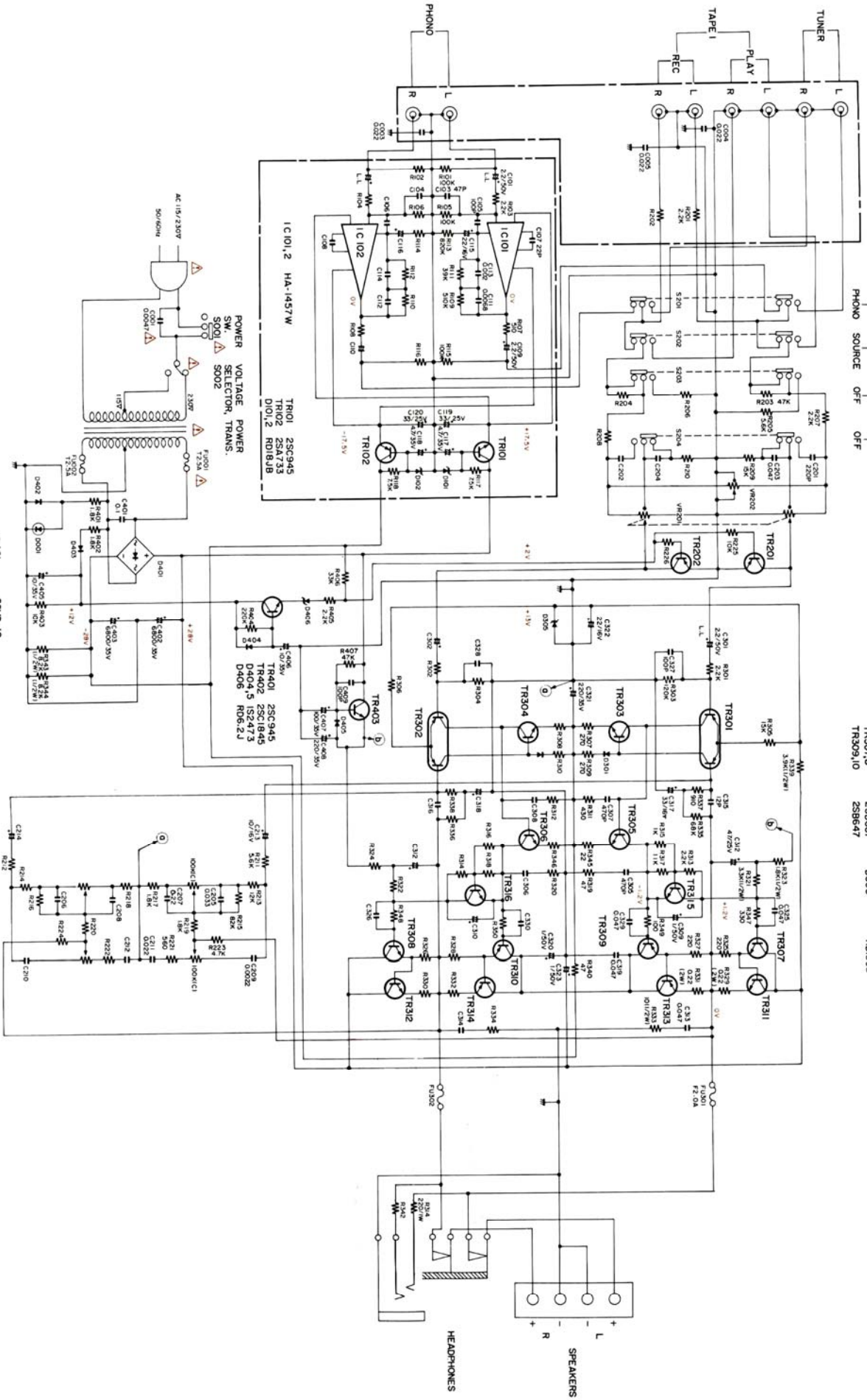

POWER VOLTAGE POWER SW. SELECTION, TRANS. S202

D401 S2VB-10
 D402,3 1S2473
 D404 52A73
 D405 52A73
 D406 52A73

WIRING DIAGRAM

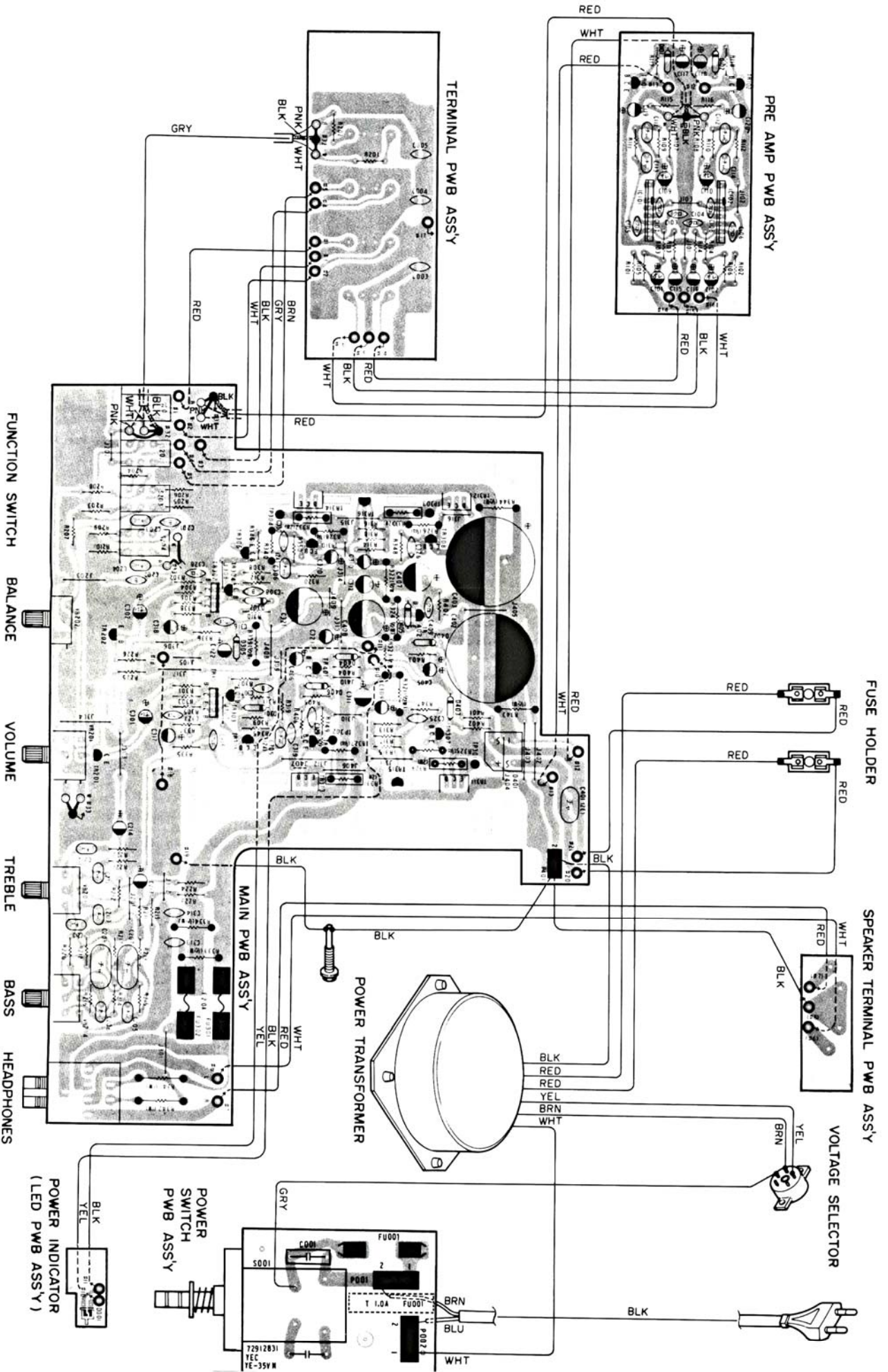

REPLACEMENT PARTS LIST

EXPLODED VIEW NO.	SYMBOL NO.	PART NO.	DESCRIPTIONS	Q'TY	REMARKS
----------------------	------------	----------	--------------	------	---------

TRANSISTORS

	TR101, 303, 304, 315, 316, 401	35047217	2SC945Q	6	
	TR102	35003517	Transistor, 2SA733/733A	1	
	TR301, 302	35901207	Transistor, 2SA798G	2	
	TR313, 314	35902325	Transistor, 2SA769Y	2	
	TR201, 202	35902912	Transistor, 2SA952L	2	
	TR309, 310	35921903	Transistor, 2SB647C	2	
	TR305, 306, 402	35947406	Transistor, 2SC1845F	3	
	TR311, 312	35947625	Transistor, 2SC1827Y	2	
	TR307, 308	35962203	Transistor, 2SD667C	2	

DIODES

	D301, 302, 402, 403, 404, 405	360K1009	Diode, 1S2473AT	6	
	D401	36902063	Rectifier, S2VB10	1	
	D001	36904077	LED, GL-2PR1	1	
	D406	3690512	Diode, Zener RD6.2JB	1	
	D305	36905129	Diode, Zener RD13JB	1	
	D101, 102	36905132	Diode, Zener RD18JB	2	

ICs

	IC101, 102	37901058	IC, HA1457W		
--	------------	----------	-------------	--	--

RESISTORS

	R341, 342	40351157	R, Metal 220 Ω 5% 1W	2	
	R333, 334	40912125	R, Carbon 10 Ω 5% ½W	2	
	R323, 324	40912179	R, Carbon 1.8k Ω 5% ½W	2	
	R321, 322	40912185	R, Carbon 3.3k Ω 5% ½W	2	

EXPLODED VIEW NO.	SYMBOL NO.	PART NO.	DESCRIPTIONS	Q'TY	REMARKS
	R339	40912187	R, Carbon 3.9k Ω 5% 1/2W	1	
	R343, 344	40912195	R, Carbon 8.2k Ω 5% 1/2W	2	
	R340	40913141	R, Carbon 47 Ω 5% 1/4W	1	
	R325, 326, 327, 328	40913157	R, Carbon 220 Ω 5% 1/4W	4	
	R329, 330, 331, 332	40920050	R, Carbon 22 Ω 10% 1/4W	1	
	R345, 346	409H2633	R, Carbon 22 Ω 5% 1/4W	2	
	R319, 320	409H2641	R, Carbon 47 Ω 5% 1/4W	2	
	R307, 308, 309, 310	409H2659	R, Carbon 270 Ω 5% 1/4W	4	
	R347, 348, 349, 350	409H2661	R, Carbon 330 Ω 5% 1/4W	4	
	R311, 312	409H2664	R, Carbon 430 Ω 5% 1/4W	2	
	R107, 108	409H2666	R, Carbon 510 Ω 5% 1/4W	2	
	R221, 222	409H2667	R, Carbon 560 Ω 5% 1/4W	2	
	R113, 114	409H2671	R, Carbon 820 Ω 5% 1/4W	2	
	R337, 338	409H2672	R, Carbon 910 Ω 5% 1/4W	2	
	R315, 316	409H2673	R, Carbon 1k Ω 5% 1/4W	2	
	R217, 218, 219, 220, 401, 402	409H2679	R, Carbon 1.8k Ω 5% 1/4W	6	
	R103, 104, 201, 202, 207, 208, 301, 302, 313, 314, 405	309H2681	R, Carbon 2.2k Ω 5% 1/4W	11	
	R223, 224	409H2689	R, Carbon 4.7k Ω 5% 1/4W	2	
	R205, 206, 211, 212	409H2691	R, Carbon 5.6k Ω 5% 1/4W	4	
	R117, 118	409H2694	R, Carbon 7.5k Ω 5% 1/4W	2	
	R225, 226, 403	409H2697	R, Carbon 10k Ω 5% 1/4W	3	
	R317, 318	409H2698	R, Carbon 11k Ω 5% 1/4W	2	
	R213, 214	409H2699	R, Carbon 12k Ω 5% 1/4W	2	
	R209, 210, 305, 306	409H2701	R, Carbon 15k Ω 5% 1/4W	4	
	R406	409H2709	R, Carbon 33k Ω 5% 1/4W	1	
	R111, 112	409H2711	R, Carbon 39k Ω 5% 1/4W	2	
	R203, 204, 407	409H2713	R, Carbon 47k Ω 5% 1/4W	3	
	R335, 336	409H2717	R, Carbon 68k Ω 5% 1/4W	2	
	R215, 216	409H2719	R, Carbon 82k Ω 5% 1/4W	2	
	R101, 102, 105, 106 115, 116	409H2719	R, Carbon 100k Ω 5% 1/4W	6	
	R303, 304	409H2723	R, Carbon 120k Ω 5% 1/4W	2	
	R404	409H2729	R, Carbon 220k Ω 5% 1/4W	1	
	R109, 110	409H2738	R, Carbon 510k Ω 5% 1/4W	2	

CONTROLS

		41950385	Variable Resistor 100k Ω C	2	
	VR201	41950398	Variable Resistor 150k Ω B	1	
	VR202	41950404	Variable Resistor 500k Ω (W)	1	

EXPLODED VIEW NO.	SYMBOL NO.	PART NO.	DESCRIPTIONS	Q'TY	REMARKS
-------------------	------------	----------	--------------	------	---------

CAPACITORS

	C003, 004, 005	42110429	C, Ceramic	50V 0.022 μ F	3	
	C313, 314, 325, 326, 329, 330	42110433	C, Ceramic	50V 0.047 μ F	6	
	C319	42110933	C, Ceramic	50V 0.047 μ F	1	
	C307, 308	42130209	C, Ceramic	50V 470pF	2	
	C315, 316	42332023	C, Ceramic	50V 12pF	2	
	C107, 108	42332029	C, Ceramic	50V 22pF	2	
	C103, 104	42332037	C, Ceramic	50V 47pF	2	
	C105, 106, 327, 328, 409	42332045	C, Ceramic	50V 100pF	5	
	C001	42606011	C, MP	250V 4700pF	1	
	C207, 208	42974002	C, Poly	50V 0.022 μ F	2	
	C205, 206	42974003	C, Poly	50V 0.33 μ F	2	
	C209, 210	42974012	C, Poly	50V 2200pF	2	
	C111, 112	42974015	C, Poly	50V 6800pF	2	
	C203, 204	42974022	C, Poly	50V 47000pF	2	
	C113, 114	42974033	C, Poly	50V 2000pF	2	
	C211, 212	42974065	C, Poly	50V 22000pF	2	
	C201, 202	42974209	C, Poly	100V 220pF	2	
	C305, 306	42974217	C, Poly	100V 470pF	2	
	C401	42974307	C, Poly	500V 0.1 μ F	1	
	C402, 403	43970085	C, Elec.	35V 6800 μ F	2	
	C101, 102, 109, 110, 301, 302	43980055	C, Elec.	50V 22 μ F	6	
	C213, 214	43993024	C, Elec.	16V 10 μ F	2	
	C115, 116, 322	43993025	C, Elec.	16V 22 μ F	3	
	C317, 318	43993026	C, Elec.	16V 33 μ F	2	
	C119, 120	43993039	C, Elec.	25V 33 μ F	2	
	C311, 312	43993040	C, Elec.	25V 47 μ F	2	
	C117, 118	43993048	C, Elec.	35V 4.7 μ F	2	
	C405, 406	43993049	C, Elec.	35V 10 μ F	2	
	C407	43993053	C, Elec.	35V 100 μ F	1	
	C321, 408	43993054	C, Elec.	35V 220 μ F	2	
	C309, 310, 320, 323	43993060	C, Elec.	50V 1 μ F	4	

EXPLODED VIEW NO.	SYMBOL NO.	PART NO.	DESCRIPTIONS	Q'TY	REMARKS
-------------------	------------	----------	--------------	------	---------

KNOBS

2		18462691	Knob, Volume Control (A210ME)	1	
		18461851	Knob, Volume Control (A225ME)	1	
3		18462531	Knob, Bass/Treble/Balance (A210ME)	3	
		18461871	Knob, Bass/Treble/Balance (A225ME)	3	
4		18461891	Knob, Push Button	4	

ELECTRIC PARTS

205		65901053	Switch, Voltage Selector	1	
207		66901068	Fuse 2.0A SEMKO	2	
209		45019128	Power Transformer	1	
210		65904152	Push Switch	1	
212		65904151	Push Switch	1	
		66901023	Fuse 2.5A SEMKO	2	
217		87B34101	Main PWB Ass'y	1	
218			Pre Amp. PWB Ass'y	1	
219			Terminal PWB Ass'y	1	
220			Selector Switch PWB Ass'y	1	
221			LED PWB Ass'y	1	
222		87B34201	Power Switch PWB Ass'y	1	

MISCELLANEOUS PARTS

1		18714811	Front Panel (A210ME)	1	
		18715891	Front Panel (A225ME)	1	
5		18404501	Collar, Knob	5	
6		18356141	Cabinet (A210ME)	1	
		18356201	Cabinet (A225ME)	1	
7		18604621	Sheet, Cabinet	1	
8		18518141	Sub Chassis	1	
9		18517612	Chassis Base	1	
10		18290641	Foot	4	
11		18517641	Shield Plate B	1	
12		18517701	Stud	4	
13		18517801	Power Switch Bracket	1	
14		18289551	Clamper	1	
15		18604601	Plastic Plate	1	
16		18517691	Heat Sink	2	
17		18517632	Shield Plate A	1	
18		18290441	PWB Holder	3	
19		18518921	Rear Panel (A210ME)	1	
		18520341	Rear Panel (A225ME)	1	
20		24280261	Cord Clamper	1	
21		18513901	Stud	2	

EXPLODED VIEW NO.	SYMBOL NO.	PART NO.	DESCRIPTIONS	Q'TY	REMARKS
22		91430302	Hex. Nut 3 x 15CF	2	
101		23850891	Special Screw	6	
102		91053032	Screw, CFIMS 3 x 6 x 15CF	2	
103		24851541	Screw, FT3 x 6 x 15BF	9	
104		18852741	Special Screw	2	
105		18852691	Screw, PT 4 x 8 x 15BF	4	
106		18850871	Push Rivet	2	
107		24851801	Push Rivet	1	
108		23850871	Special Screw	5	
109		18854481	Special Screw	4	
110		18852161	Special Screw	4	
1111		91283051	Screw, #2CPTS 3 x 8 x 15BF	2	
112		91013086	Screw, CPIMS 3 x 14 x 3KF	2	
113		18852771	Special Screw	8	
114		23850741	Push Rivet	4	
201		70803014	Power Cord CENELEC	1	
202		71905137	Earth Terminal	1	
203		71905134	Terminal Strip 4P	2	
204		71905170	Speaker Terminal 4P	1	
206		71205031	Fuse Holder 1P	2	
213		70905250	Headphone Jack	1	
		18604892	Filler, Front Panel	2	
		71205034	Fuse Holder	4	

PACKING MATERIALS

		18801032	Polyethylene Bag (1/12)	1	
		18806502	Filler, Carton	2	
		18806531	Polyethylene Bag	1	
		18806941	Filler, Carton	1	
		18807241	Individual Carton	1	
		78912891	Instruction Booklet	1	