

NEC

MODEL AUP-6100E (SG)

BELT-DRIVE TURNTABLE SERVICE MANUAL

SER. NO. 4058



Better Service
Better Reputation
Better Profit



SPECIFICATIONS

TURNTABLE SPECIFICATIONS NOMINAL VALUE

Drive Motor 4-pole synchronous Motor
Drive System Belt Drive
Platter 310 mm diameter aluminum die-cast
weight: 0.7 kgs
Wow & Flutter 0.065% (WARMS)
Signal to Noise Ratio 63 dB (DIN-B)
Speed 33-1/3 & 45 RPM 2-speed

TONEARM SPECIFICATIONS

Tonearm Type Statically-balanced S-shaped tubular
arm with direct reading tracking
force adjustment, oil-damped cue-
ing mechanism and anti-skating
device.
Tonearm Effective Length 215 mm pivot to stylus
Overhang 16 mm
Acceptable Cartridge Weight 4 ~ 10 grms

CARTRIDGE PERFORMANCE NOMINAL VALUE

Cartridge Type Moving Magnet Type
Frequency Response 20 ~ 16,000 Hz
Channel Balance Within 1.5 dB at 1 KHz
Crosstalk between Channels 25 dB at 1 KHz
Output Voltage 3.0 mV at 1 KHz 50 mm/sec.
Optimum Load 47 K Ω
Tracking Force 2.0 \pm 0.5 grams
Stylus 0.7 mil diamond

OTHER SPECIFICATIONS

Power Supply 110/120V, 220/240V AC 50/60Hz
Dimension
Cabinet 450 (W) x 45 (H) x 350 (D) mm
Overall 450 (W) x 130 (H) x 350 (D) mm
Weight Approximately 5.2 kgs
Dust Cover Removable hinged dust cover

NOTE: The above specifications are subject to change
without notice for further improvement.

Nippon Electric Co., Ltd.

TOKYO, JAPAN

NAME OF PARTS AND ACCESSORIES

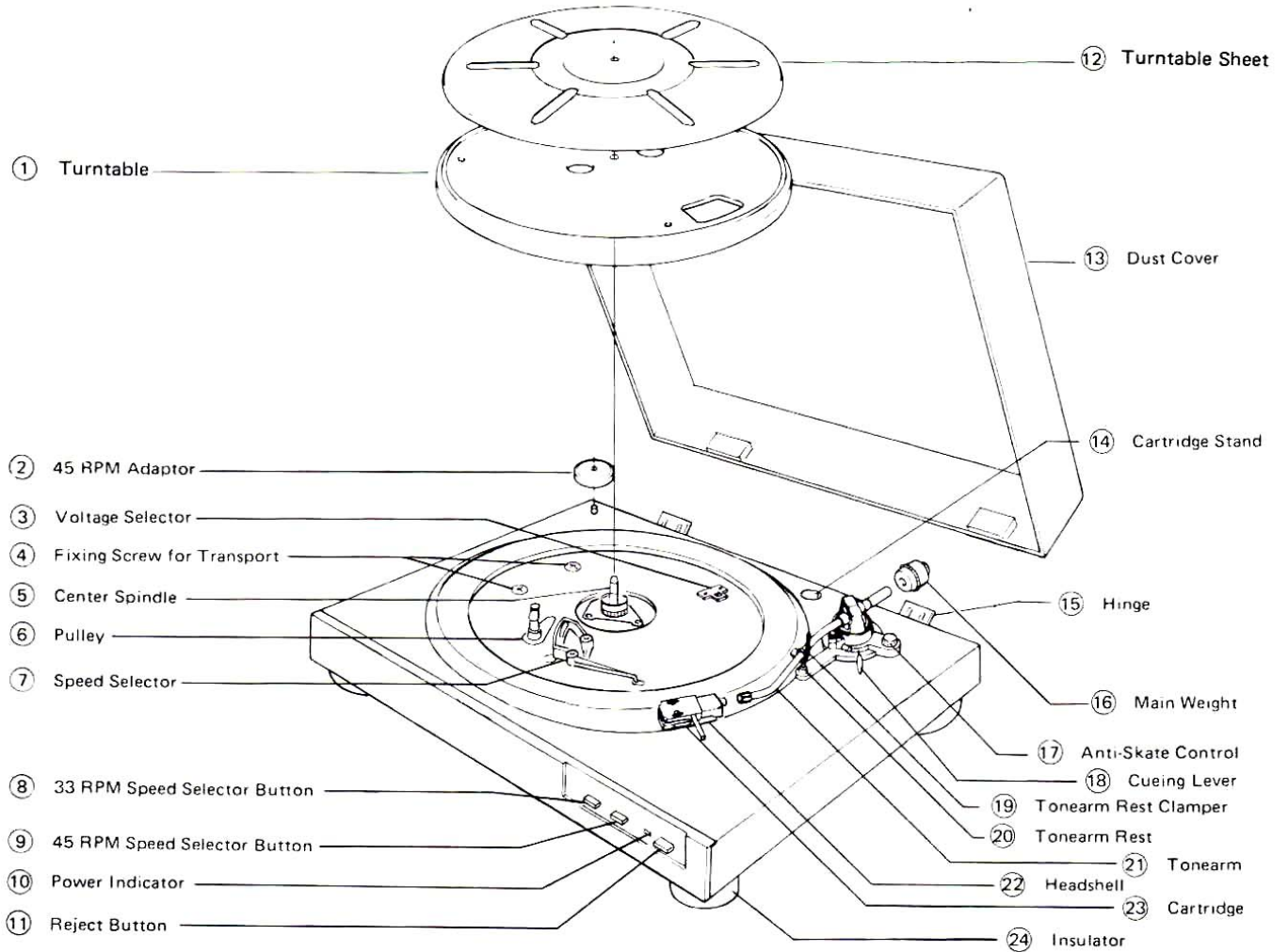

ACCESSORIES

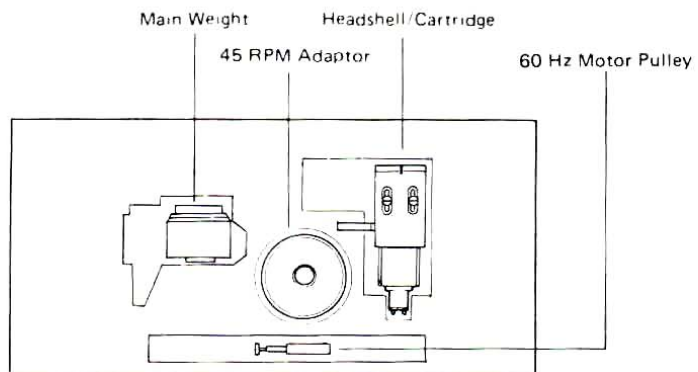

1. ASSEMBLING TONEARM

(1) Attaching Main Weight

Mount the Main Weight onto the rear end of the tonearm shaft, as shown in Fig. 1, and turn it a few times. Leave it the way it is until you adjust the tracking force as instructed later.

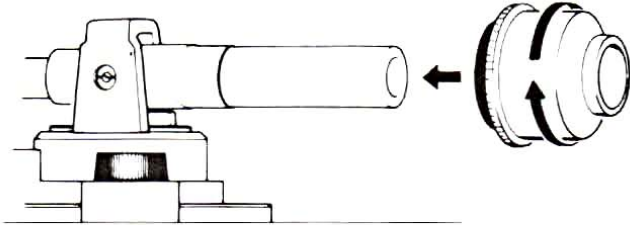

Fig. 1 Attaching the main weight

(2) Connecting Headshell

Insert the connector of the headshell into the front end of the shaft, then fix it by turning the lock nut, as shown in Fig. 2.

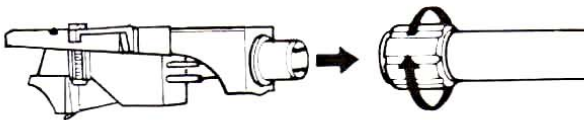

Fig. 2 Connecting the headshell

(3) Adjusting Horizontal Balance

- 1) Set the Anti-Skate Control to "0".
- 2) Pull the Cueing Lever down toward yourself.
- 3) Pull the stylus cover off the cartridge.
- 4) Release the tonearm from the tonearm rest (Fig. 3).
The tonearm will swing up or down, or sideways, and so care must be taken to avoid damage to the stylus.
- 5) Turn the Main Weight and move it forward or backward to balance the entire tonearm support. Leave the Main Weight where it balances the tonearm horizontally, as shown in Fig. 4.
- 6) When the above adjustment is finished, replace the stylus cover, return the tonearm to the tonearm rest, and lift the Cueing Lever up as before.
- 7) With the tonearm balanced horizontally, it has a tracking force of "0" gram. In preparation for tracking force adjustments, therefore, turn only the Tracking Force Dial to set the dial to read "0" on the reference line of the tonearm shaft. Be sure not to turn the entire Main Weight yet as it will spoil the horizontal balance of the tonearm.

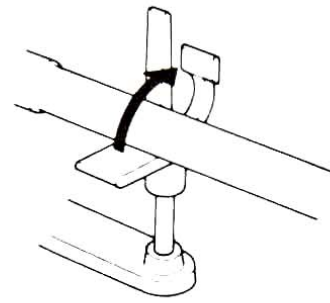

Fig. 3 Releasing the tonearm

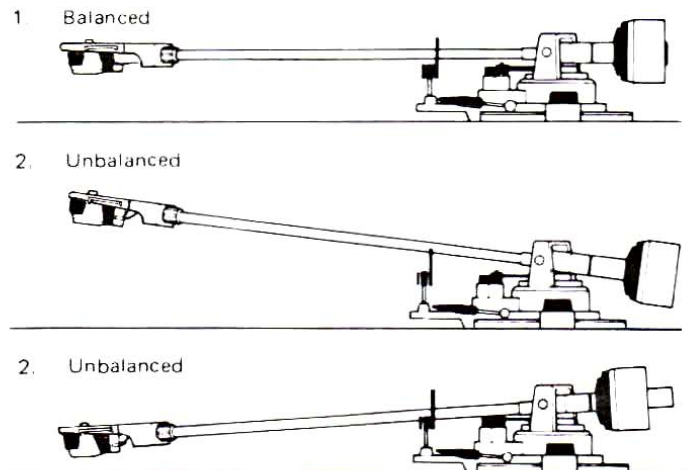

Fig. 4 Adjusting the horizontal balance

(4) Adjusting Tracking Force

Turn the Main Weight until the Tracking Force Dial indicates the appropriate tracking force for your cartridge.

The standard cartridge provided operates best with a tracking force of 2.0 grams, and so if you are using it, adjust the dial to 2.0 grams as shown in Fig. 5.

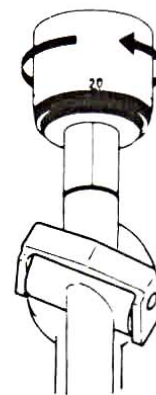

Fig. 5 Adjusting tracking force

2. REPLACING STYLUS

To replace the stylus, first loosen the lock nut of the tonearm, and remove the headshell from the tonearm. Then the entire stylus holder may be pulled off the cartridge, as illustrated. To mount a new stylus, simply reverse the procedure, but take care not to damage the stylus tip.

- (1) The life of a diamond stylus is anywhere from 800 to 1,000 hours, but it is recommended to replace it earlier for best record playing results.
- (2) The replacement stylus for the cartridge provided is designated the NEC LP-6100D, and may be purchased from your NEC dealer.

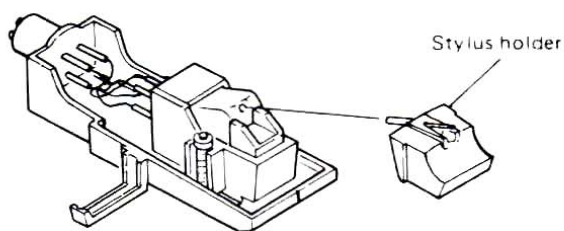

Fig. 6 Replacing stylus

3. REPLACING CARTRIDGE

When you wish to replace the cartridge, proceed as follows:

- (1) Loosen the lock nut of the tonearm, and remove the headshell from the tonearm.
- (2) Loosen the screws fastening the cartridge to the headshell, then remove the cartridge from the headshell.
- (3) Remove the four lead wires of the headshell from the cartridge, taking care not to damage the wires.
- (4) Connect the four lead wires to the new cartridge. The four lead wires are colour-coded as shown in Fig. 7 to help identify their polarities. Be sure to match the polarities correctly between the headshell and the new cartridge.
- (5) Secure the cartridge to the headshell tentatively (not too firmly).
- (6) Adjust the overhang. This is accomplished by moving the tonearm all the way to above the center spindle of

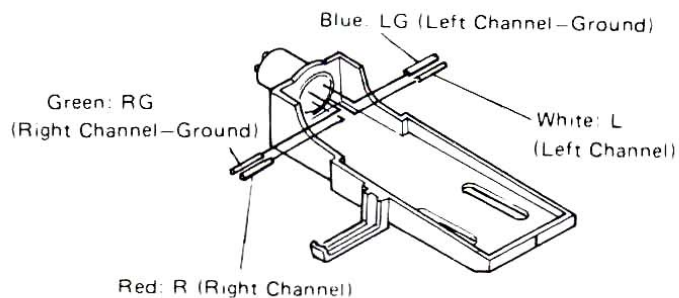

Fig. 7 Replacing cartridge

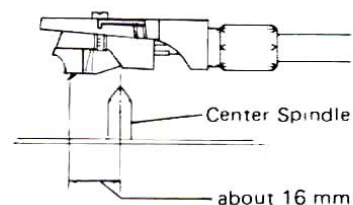

Fig. 8 Adjusting overhang

the platter, sliding the cartridge inside the headshell back and force, and fixing it so that the distance between the stylus tip and the center of the center spindle is about 16 mm, as shown Fig. 8.

- (7) When the above adjustment is finished, re-adjust the horizontal balance of the tonearm, the tracking force and Anti-Skate Control following the instructions given in Item 3. above. Be sure to adjust the tracking force to the AUP-6100E.
 - 1) Any cartridge weighing from 4 to 10 grams may be used with the AUP-6100E.
 - 2) Some cartridges may produce hum noise. If this happens, it may be reduced by disconnecting the grounding lead of the turnable from your stereo amplifier (read the operating manual of the cartridge for more detail).

ALIGNMENT PROCEDURE

1. CHECK ON CLEARANCE BETWEEN MICRO SWITCH AND FEED ARM

- (1) Clearance between micro switch and feed arm
(Check the clearance with R gear set at the stop position.)

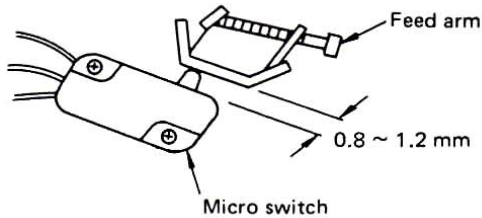

Fig. 9

- When the clearance is larger than specified, loosen two screws on the micro switch and after pushing it toward the feed arm, tighten the screws. (In case the clearance is smaller, pull the micro switch away from the feed arm after loosening the screws and tighten them.)

- (2) Start position

- Make adjustment so as to turn on the micro switch to start turning the turntable when the needle is in a range of 155 ~ 170 mm from the center of the turntable. (The micro switch must be turned on by shifting the pickup toward the center of the turntable. The clearance between the micro switch and the feed arm must remain as specified above.)

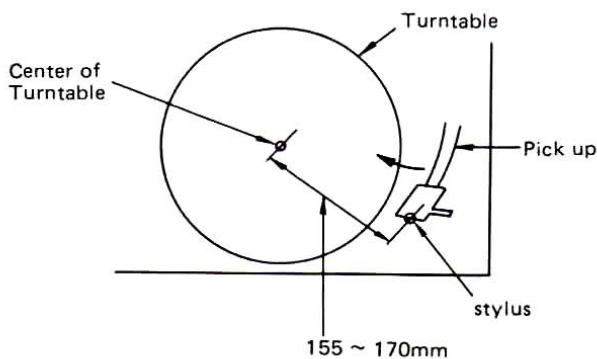

Fig. 10

- Position of feed arm

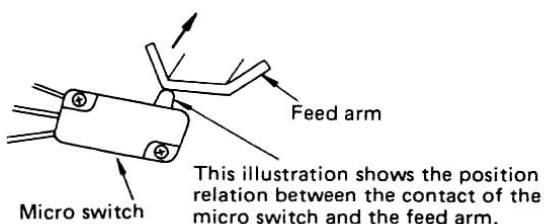

Fig. 11

2. ADJUSTMENT OF RETURN POSITION

- (1) Check on start position

- Make sure that the turntable starts turning when the needle comes in a range of 155 ~ 170 mm from the center of the turntable, to turn on the micro switch.
- If the turntable fails to start turning when the needle comes in the range, make adjustment after loosening the screw which fixes the feed arm in place.

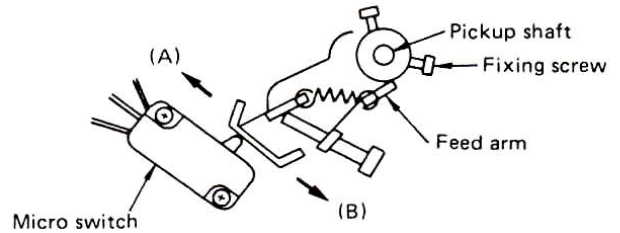

Fig. 12

When the start is too late, move the feed arm in the direction of (B).

When the start is too early, move the feed arm in the direction of (A).

- (2) Return position

- With the grooves with a 3-mm pitch of the test record in use, adjust the feed arm by turning the adjusting screw so as to enable the pickup to return in a range of 65 to 56 mm.
- Range of 65 to 56 mm expressed in terms of the number of counts: 13 ~ 16 counts.
(Standard: 10 ~ 20 counts)
- Make adjustment so as to enable the pickup to return with the counts being 14, 15 or 16.

3. ADJUSTMENT OF ELEVATION OF STYLUS

- (1) Adjust to 4 ~ 14 mm the elevation of the stylus from the surface of a record, by turning the elevation plate adjustment screw.

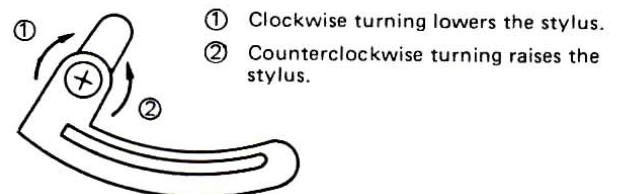

Fig. 13

WIRING DIAGRAM

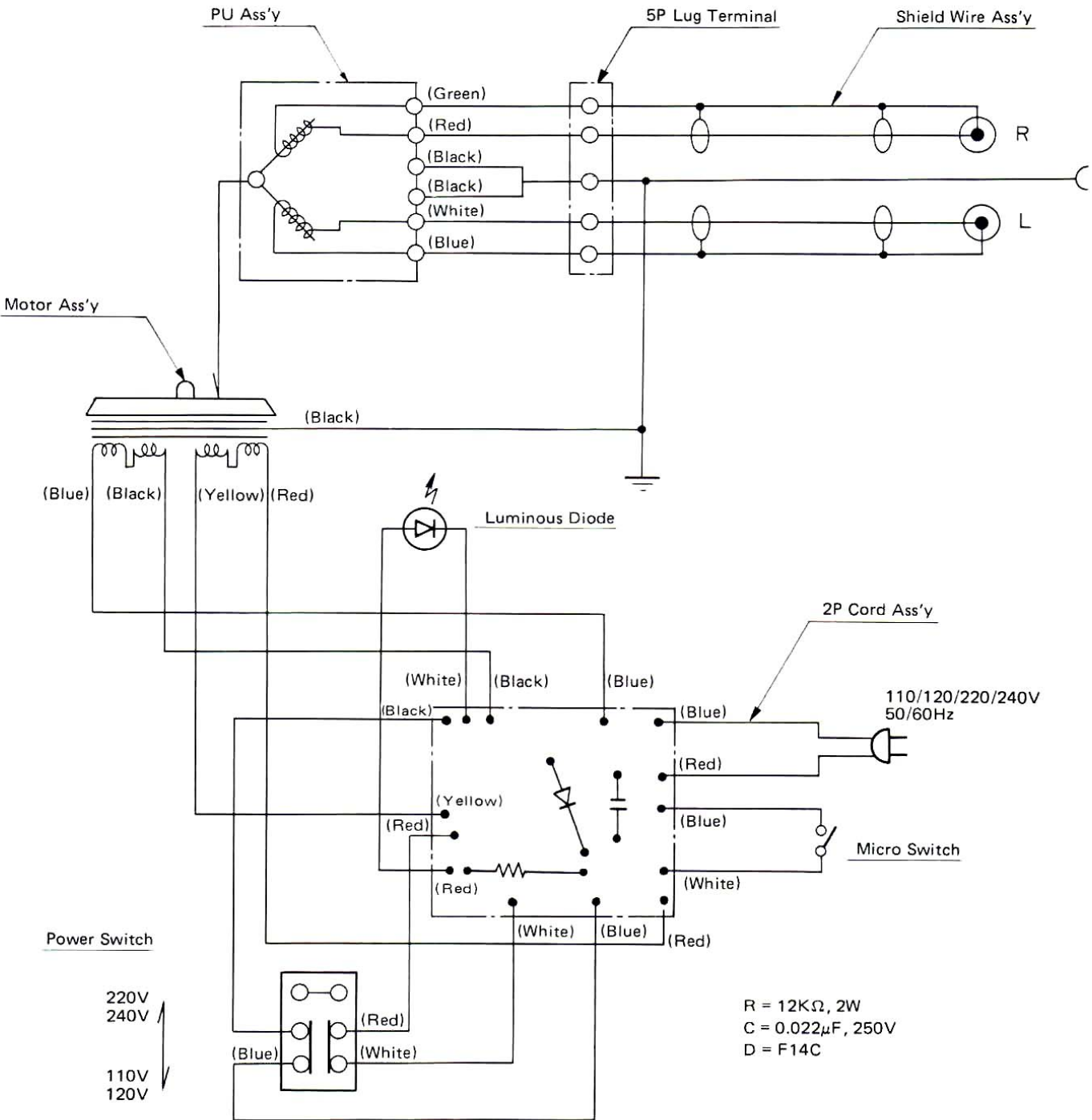
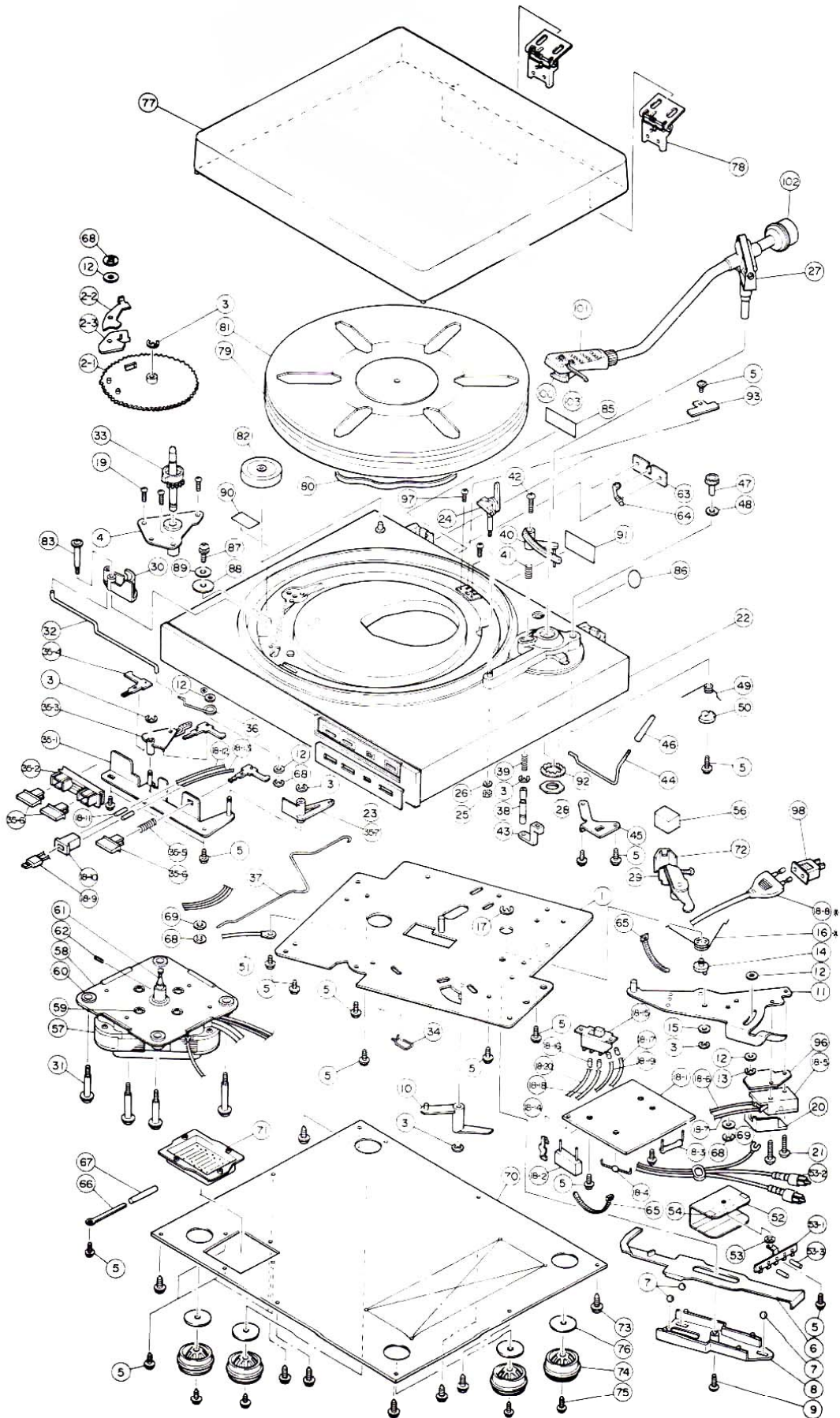

TABLE OF TROUBLESHOOTING INSTRUCTIONS

SYMPTOM	CAUSE	REMEDY
Platter does not revolve.	<ul style="list-style-type: none"> ● Power cable is unplugged. 	<ul style="list-style-type: none"> ■ Insert power cable firmly into AC outlet.
No sound.	<ul style="list-style-type: none"> ● Connection cords are unplugged from stereo amplifier. ● Headshell is not connected properly. ● FUNCTION switch of stereo amplifier is set to wrong position. ● TAPE MONITOR switch of stereo amplifier is set to TAPE (or Monitor). ● Lead wires of cartridge are disconnected. 	<ul style="list-style-type: none"> ■ Connect cords firmly. ■ Tighten lock nut. ■ Set FUNCTION switch to PHONO. ■ Set TAPE MONITOR switch to SOURCE. ■ Connect lead wires firmly to terminal pins of headshell.
Tempo of reproduced music is strange.	<ul style="list-style-type: none"> ● Speed Selector is in wrong position. 	<ul style="list-style-type: none"> ■ Reset Speed Selector to correct speed for record.
Sound is noisy.	<ul style="list-style-type: none"> ● Dust or dirt on record surface. ● Dust or dirt on stylus. ● Tracking force is too light. ● Stylus is worn. ● Grounding lead is not connected to amplifier. 	<ul style="list-style-type: none"> ■ Clean record surface. ■ Clean stylus. ■ Adjust for proper tracking force. ■ Replace stylus. ■ Connect grounding lead to amplifier.
Sound is distorted.	<ul style="list-style-type: none"> ● Stylus is worn. ● Dust or dirt on stylus. ● Tracking force is too light. ● Overhang adjustment is wrong. 	<ul style="list-style-type: none"> ■ Replace stylus. ■ Clean stylus. ■ Adjust for proper tracking force. ■ Re-adjust overhang.
Loud howling noise.	<ul style="list-style-type: none"> ● Howling phenomenon. 	<ul style="list-style-type: none"> ■ Move turntable away from speaker systems.
Stylus moves irregularly.	<ul style="list-style-type: none"> ● Turntable is not placed on horizontal plane. ● Tracking force is too light, and Anti-Skate Control is not adjusted. 	<ul style="list-style-type: none"> ■ Place turntable on horizontal plane. ■ Re-adjust tracking force and Anti-Skate Control.

EXPLODED VIEW OF SET



REPLACEMENT PARTS LIST

SYMBOL NO.	PART NO.	DESCRIPTION	Q'TY	REMARKS
2	18988191	R-Gear Ass'y (2)	1	
6	18984261	Actuating Arm	1	
10	18988301	Kick Lever	1	
11	18991111	Actuating Plate Ass'y	1	
14	18988341	Eccentric Pin 2	1	
18	18991321	Power Supply PWB Ass'y	1	
18-4	18990701	Diode, F14C	1	
18-5	18991031	Micro Switch	1	
18-8	18991341	2P Cord Ass'y	1	
18-9	18988471	Luminous Diode	1	
18-15	18991331	Selector Switch	1	
22	18991251	Cabinet	1	
23	18988571	Operation Plate Instruction	1	
24	18988581	Rest Base Ass'y	1	
27	18988611	Pick Up Ass'y	1	
29	18988631	Forward Arm Ass'y (2)	1	
30	18991151	Belt Guide	1	
33	18988671	Turntable Shaft Ass'y	1	
35	18988691	Actuating Angle Ass'y	1	
38	18988791	Elevation Shaft	1	
39	18988801	Elevation Spring	1	
40	18988811	Elevation Plate	1	
43	18988841	Cueing Arm	1	
44	18988851	Cueing Lever	1	
45	18988861	Pick Up Base Plate	1	
46	18988871	Knob, Lifter Lever	1	
47	18988881	IFC Knob Ass'y	1	
49	18988901	IFC Spring	1	
50	18988911	IFC Cam	1	
53	18988941	5P Lug Plate Ass'y	1	
57	18989011	Motor Ass'y	1	

SYMBOL NO.	PART NO.	DESCRIPTION	QTY	REMARKS
61	18991171	Motor Pulley	1	
70	18989141	Bottom Plate	1	
72	18989161	Forward Arm Cover	1	
74	18989181	Foot	4	
77	18989211	Dust Cover	1	
78	18989221	Hinge Ass'y	2	
79	18989231	Turntable	1	
80	18989241	Belt	1	
81	18989251	Turntable Sheet	1	
82	18989261	45 rpm Adaptor	1	
84	18991311	Caution Label	1	
85	18989291	Serial No. Label	1	
86	18953101	Passed Label	1	
88	18989311	Caution Tag	2	
91	18991291	Model Name Instruction	1	
93	18991281	Voltage Instruction	1	
98	70599039	AC Adaptor	1	
100	18991211	Cartridge	1	
101	18991241	Headshell	1	
102	18991231	Main Weight	1	
103		Stylus, LP-6100/6300DE	1	