

# NEC

**Authentic series**  
**BELT-DRIVE AUTOMATIC TURNTABLE**  
**SERVICE MANUAL**

MODEL AUP-7300E

SER. No. 4028



**Better Service**  
**Better Reputation**  
**Better Profit**



## SPECIFICATIONS

### TURNTABLE SPECIFICATIONS

	NOMINAL VALUE
Drive Motor . . . . .	Coreless, slotless, brushless, 2-phase 8-pole magnet field type flat DC motor.
Speed control & drive system. . . . .	FG Servo controlled direct drive.
Platter. . . . .	310 mm diameter aluminum die-cast weight: 1.4 kgs.
Wow & Flutter . . . . .	0.03% WRMS.
Signal to Noise Ratio . . . . .	67 dB (DIN-B).
Speed . . . . .	33-1/3 & 45 RPM 2-speed.
Speed Pitch Control Range . . . . .	±4%

### TONEARM SPECIFICATIONS

Tonearm Type . . . . .	Statically-balanced S-shaped tubular arm with direct reading tracking force adjustment, oil-damped cueing mechanism and anti-skating device.
Tonearm Effective Length. . . . .	.224 mm pivot to stylus.
Tonearm Suspension System . . . . .	GIMBAL suspension.
Overhang . . . . .	13 mm.
Acceptable Cartridge Weight . . . . .	5-10 grms.
Tonearm Operation . . . . .	Electronically controlled and operated by an independent DC motor.

### CARTRIDGE PERFORMANCE. . . . . NOMINAL VALUE

Cartridge Type . . . . .	Moving Magnet Type.
Frequency Response . . . . .	20-25,000 Hz.
Channel Balance . . . . .	Within 2dB at 1kHz.
Crosstalk between Channels. . . . .	25dB at 1kHz.
Output Voltage. . . . .	2.5mV at 1kHz 50mm/sec.
Optimum load . . . . .	47k ohms.
Tracking Force . . . . .	2.5 ± 0.5 grms.
Stylus . . . . .	0.6 mil diamond.

### OTHER SPECIFICATIONS

Power Supply . . . . .	110/120/220/240V AC 50/60 Hz.
Dimension	
Cabinet . . . . .	450W x 42H x 353D (mm).
Overall . . . . .	450W x 136H x 366D (mm).
Weight. . . . .	Approximately 10 kgs.
Dust Cover. . . . .	Removable hinged dust cover.

NOTE: The above specifications are subject to change without notice for further improvement.

**Nippon Electric Co., Ltd.**

TOKYO, JAPAN

# NAMES OF PARTS AND ACCESSORIES

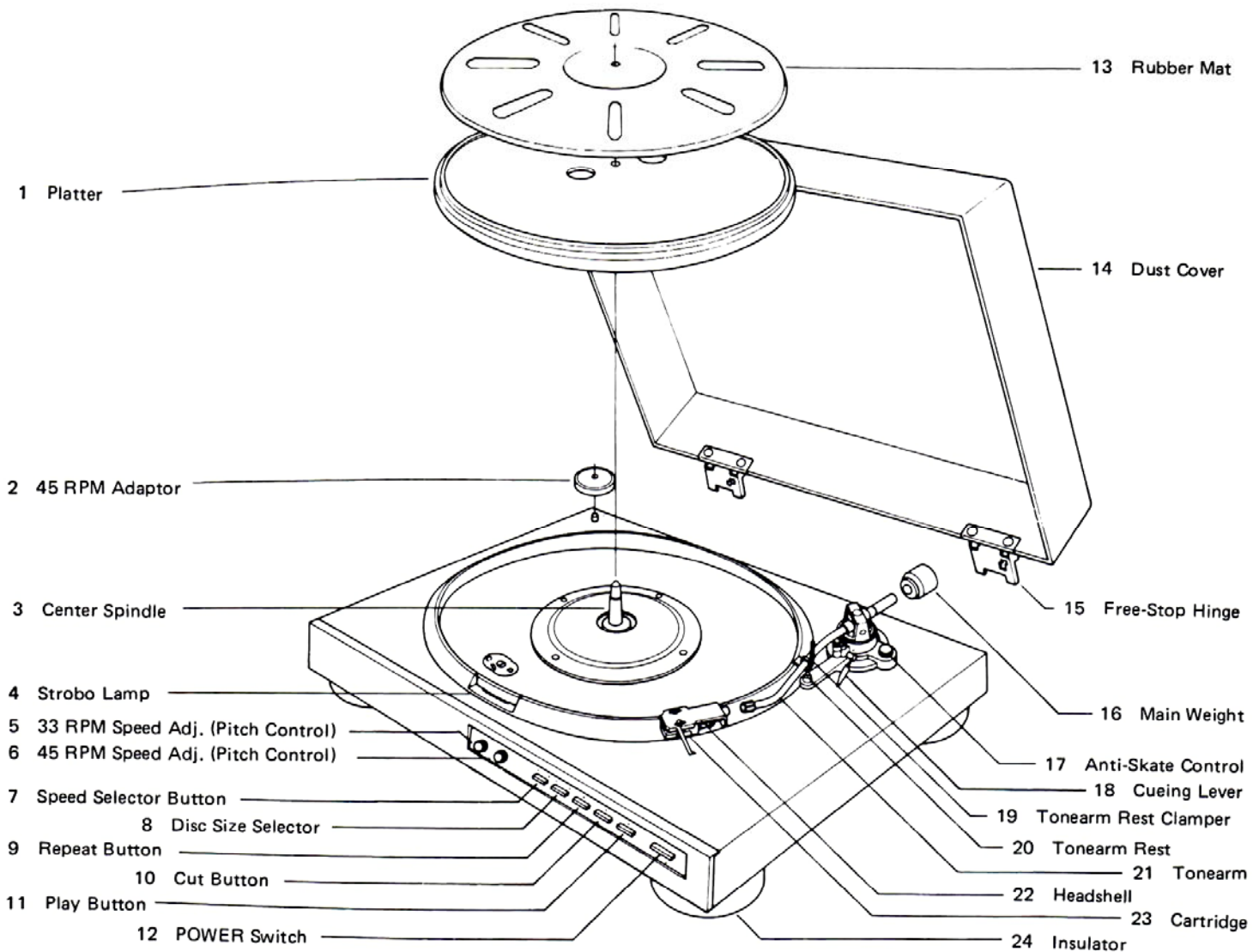

## ACCESSORY

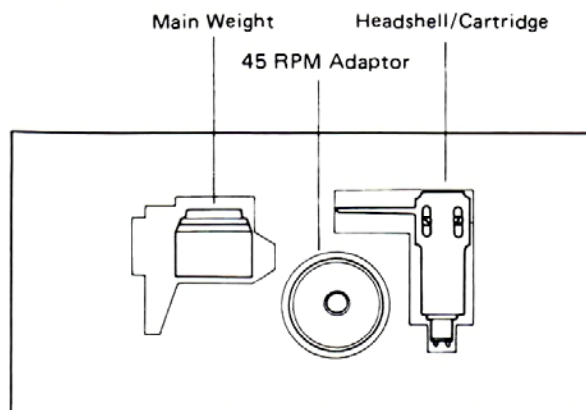

# HOW TO PLAY

## AUTO PLAY

1. Set the volume of your amplifier to minimum and turn Power switch on. Set Function switch to PHONO.
2. Turn the Power switch of this unit on (pressed).
3. Remove the stylus cover and release armrest clasper. Pull the cueing lever down toward yourself.
4. Select the speed matching with the record. Press the button for 45 rpm record (red indicator goes on) and not pressed for 33 rpm (green indicator lights).
5. Fine adjust the speed with the appropriate speed adjust control by observing the strobo pattern.
6. Select the disc size to the record you are going to play. Press the button for 17 cm disc (green indicator lights) and not pressed for 30 cm disc (red indicator lights).
7. Press the PLAY button (green indicator lights).  
The platter starts to rotate and the tonearm automatically moves onto the lead-in groove on the record, and it lowers itself to start playing.
9. Tonearm automatically returns to the armrest when the playing finishes and the platter stops its rotation (Auto return).
10. Attach the stylus cover for protection, and fix the tone arm with clasper.
  - For AUTO play, make sure to pull the cueing lever down forward yourself.
  - Operation of Disc Size Selector is not effective during Automatic operation of tonearm.

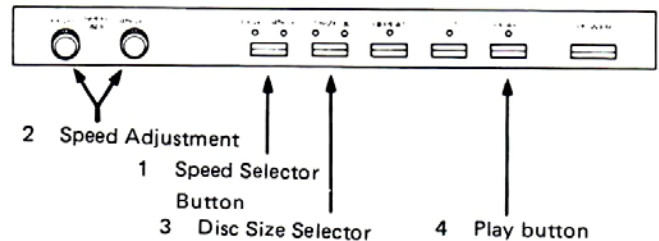
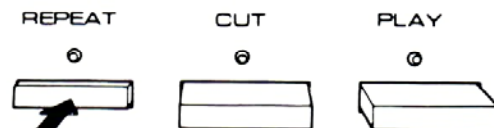

Fig. 1 Operating sequence on the front panel

## REPEAT PLAY

This is the function to repeat playing same record continuously.

1. Operate the steps (1) ~ (6) given in AUTO PLAY instruction.
2. Press REPEAT button (green indicator lights).
3. Press PLAY button. The platter starts to rotate and tonearm automatically moves and lowers itself onto the lead in groove on the record to start playing.
4. When the record finishes: the tonearm automatically returns to tonearm rest once, then moves onto the lead in groove on the record to start playing again.
5. To cancel REPEAT play, press CUT button (green indicator lights). This releases the REPEAT button and the tonearm returns to the tonearm rest, and the platter stops its rotation.  
Press CUT button at the end of a track, because if you press it in the middle of a track, the playing stops there.
  - REPEAT play can also be actuated by pressing REPEAT button after commencing the auto play.



## AUTO CUT

If you want to stop playing before the record finishes, follow the steps below.

1. Press CUT button during playing.
2. Tonearm automatically returns to the tonearm rest and the platter stops its rotation to stop playing.

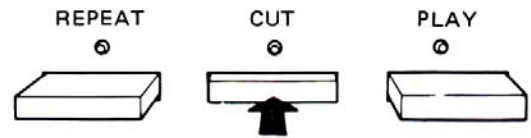

Fig. 2 CUT button – ON

## REPLACING CARTRIDGE

When you wish to replace the cartridge, proceed as follows:

1. Loosen the lock nut of the tonearm, and remove the headshell from the tonearm.
2. Loosen the screws fastening the cartridge to the headshell, then remove the cartridge from the headshell.
3. Remove the four lead wires of the headshell from the cartridge, taking care not to damage the wires.
4. Connect the four lead wires to the new cartridge. The four lead wires are colour-coded as shown right to help identify their polarities. Be sure to match the polarities correctly between the headshell and the new cartridge.
5. Secure the cartridge to the headshell tentatively (not too firmly).
6. Adjust the overhang. This is accomplished by moving the tonearm all the way to above the center spindle of the platter, sliding the cartridge inside the headshell back and force, and fixing it so that the distance between the stylus tip and the center of the center spindle is about 13 mm, as shown right.
7. When the above adjustment is finished, re-adjust the horizontal balance of the tonearm, the tracking force and Anti-Skate Control. Following the operating manual. Be sure to adjust the tracking force to the value specified by the manufacturer of the new cartridge.
  - Any cartridge weighing from 5 to 10 grams may be used with the AUP-7300E.
  - Some cartridges may produce hum noise. If this happens, it may be reduced by disconnecting the grounding lead of the turnable from your stereo amplifier (read the operating manual of the cartridge for more detail).

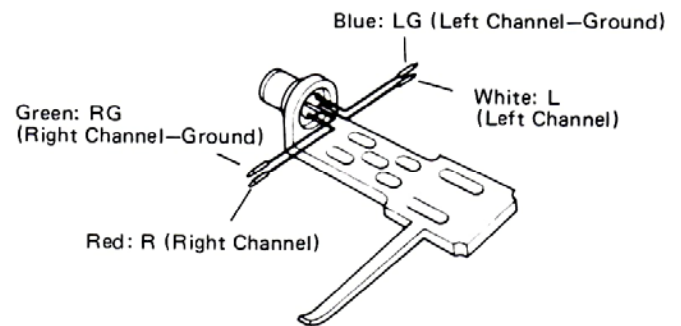

Fig. 3 Replacing Cartridge

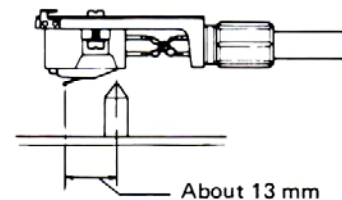

Fig. 4 Adjusting Overhang

## REPLACING STYLUS

To replace the stylus, first loosen the lock nut of the tonearm, and remove the headshell from the tonearm. Then the entire stylus holder may be pulled off the cartridge, as illustrated. To mount a new stylus, simply reverse the procedure, but take care not to damage the stylus tip.

1. The life of a diamond stylus is anywhere from 800 to 1,000 hours, but it is recommended to replace it earlier for best record playing results.
2. The replacement stylus for the cartridge provided is designated the NEC LP-8300D, and may be purchased from your NEC dealer.

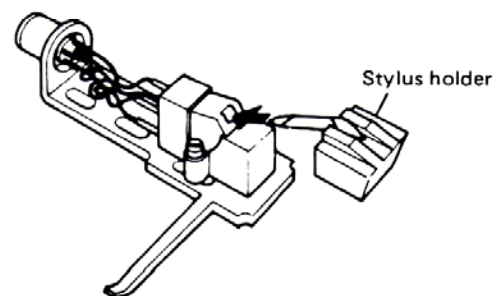

Fig. 5 Replacing Stylus

# ALIGNMENT PROCEDURE

## 1. ADJUSTMENT OF OSCILLATION FREQUENCY

In order to optically synchronize the striped pattern of the turntable at each turntable speed, adjust the oscillation frequency by setting the variable resistors, VR 101 and VR 102, on the power supply board in the following manner:

### Method of Adjustment

Hook up the frequency counter, connecting it to IC101 to locate it between No. 4 and No. 5 terminals of this IC; and set the two VRs to obtain the following frequency readings:

By VR 101 . . . . .120.00  $\pm$ 0.05 Hz at 45 rpm (Ep)

By VR 102 . . . . . 88.88  $\pm$ 0.05 Hz at 33 rpm (Lp)

**Note:** For Lp, set record size knob at 30 and speed knob at 33 rpm.

For Ep, set record size knob at 17 and speed knob at 45 rpm.

DD motor adjustments

### 1-1. Rpm adjustment

Set the fine-adjustment knob (for Ep and Lp, located on outer face of front panel) at its mechanical center (center of its angular range). Under this condition, adjust the semi-fixed variable resistors on the circuit board to freeze the strobo pattern of turntable: for this adjustment, use VR 1 (which is for 33-1/3 rpm of Lp) and VR 2 (which is for 45 rpm of Ep).

**Note:** Be sure to have record size knob set at 30 and speed knob at 33 rpm for Lp; and at 17 and 45 rpm, respectively, for Ep.

### 1-2. Wow-flutter adjustment

Use the wow-flutter test record (LF-1003). Adjust semi-fixed variable resistor VR 5 on DD circuit board to obtain the minimum value, and adjust VR 3 and VR 4 alternately to minimize wow and flutter.

## 2. ADJUSTMENTS FOR PROPER PICKUP ARM MOVEMENT

### 2-1. Return adjustment

- (a) Loosen the hexagonal head setscrew on the feed arm assembly and adjust the return by changing the angle at which the assembly is fixed.

The return will be slower if moved clockwise as seen from the bottom of the record player and faster if moved counterclockwise as seen from the same side.

#### Caution:

Care must be exercised to maintain the specified clearance between the feed arm and the friction rubber even if the setscrew of the feed arm assembly is loosened.

- (b) Sensor voltage adjustment

Put the pickup on the rest and set the voltage as follows by manipulating VR1 and VR2 attached to the control substrate. (For details, see 4-3. below.)

VR1: Pins 8 ~ 7 0.2V

VR2: Pins 8 ~ 11 0.8V

- (c) After the adjustment as specified under 2-1. (a) and (b) above, manipulate the feed arm eccentric pin as indicated in Fig. 7 below. (The record player is ready for operation at this time.)

If the pin is turned clockwise, the return will be faster (viz, the count will be faster) and if counterclockwise, it will be slower (viz, the counter will be slower).

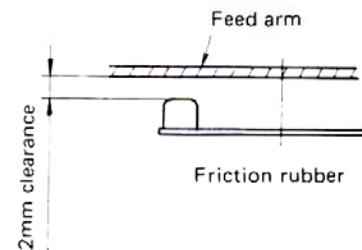

Fig. 6

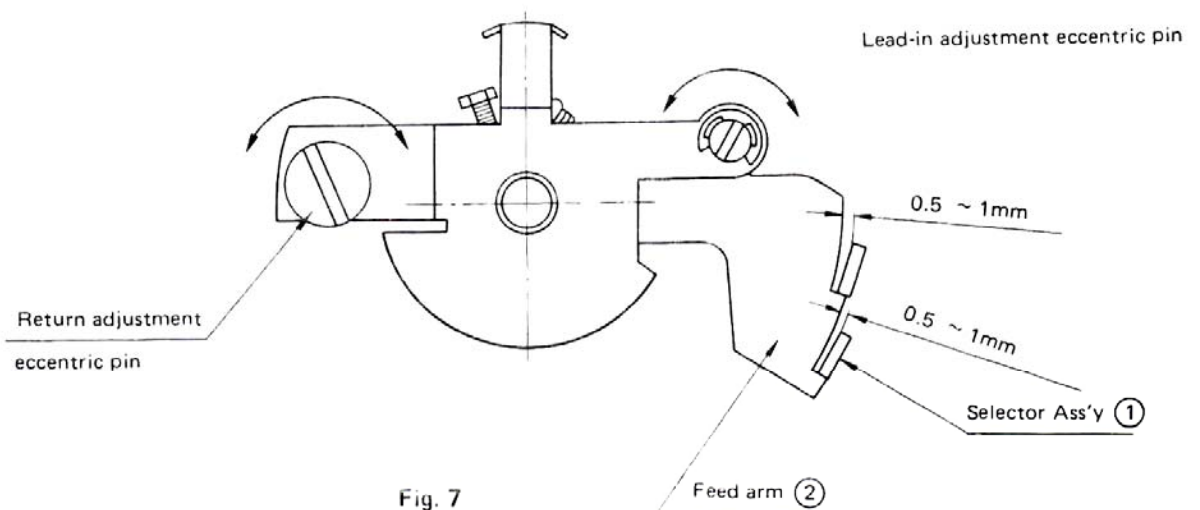

Fig. 7

## 2-2. Lead-in adjustment

### (a) Mounting of R solenoid assembly

Make one half turn of the main gear and while the selector assembly is in such a condition that it can be turned counterclockwise, turn the R solenoid cam in the direction of EP or LP and press one end of selector assembly ① into contact with the cam. Tighten the setscrew to mount the R solenoid assembly in such a position that the other end of selector assembly ① will be in contact with the cam of feed arm ② as shown in Fig. 7 above.

### (b) Lead-in adjustment

Adjust the lead-in by turning the feed arm assembly eccentric pin.

Turn the pin clockwise and the lead-in will face to the outside of the turntable. Turn it counterclockwise; the lead-in will face to the inside.

View from the bottom of the record player

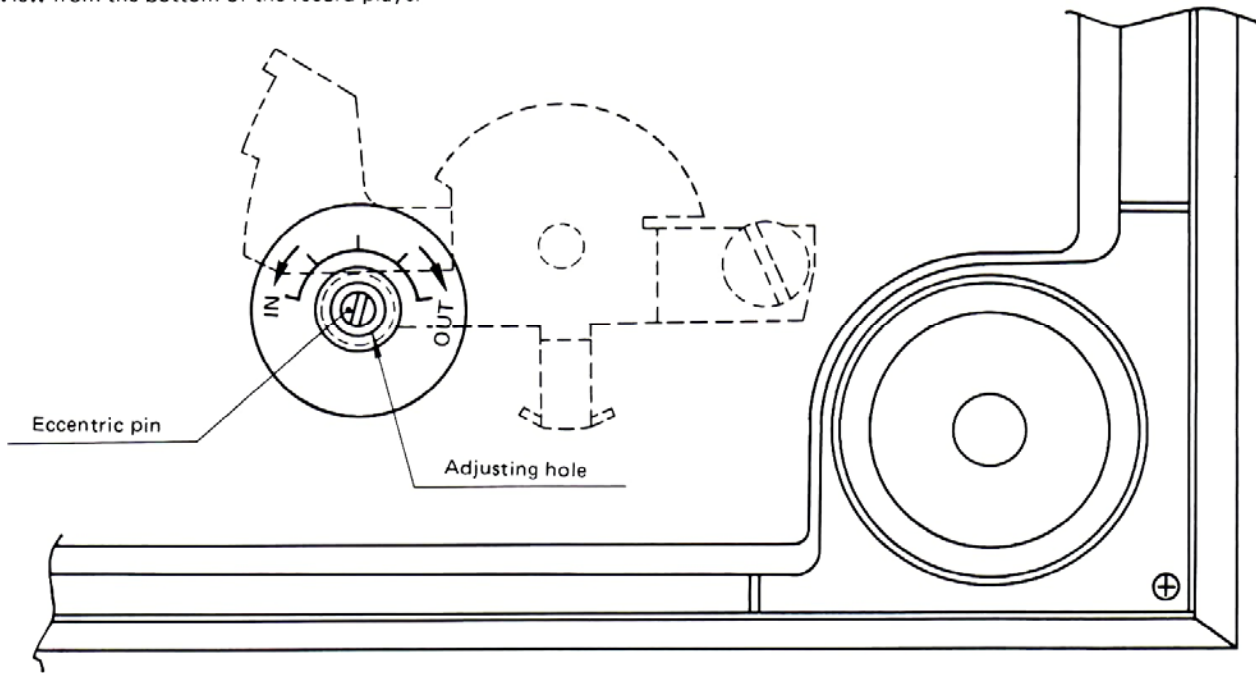
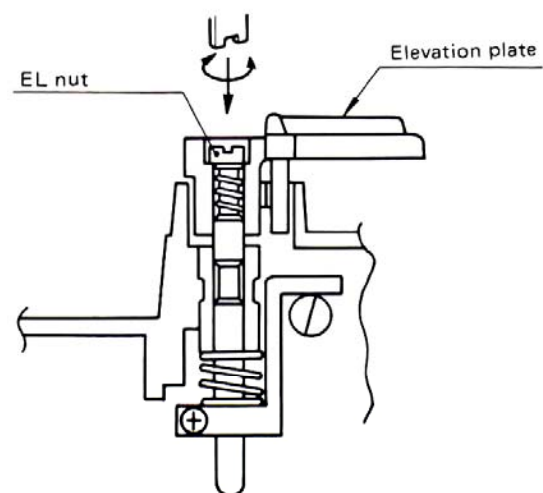

Fig. 8

## 2-3. Elevation plate adjustment

Adjust the height of the elevation plate by turning the EL nut.

The plate goes up by turning it clockwise and down by turning it counterclockwise.



### 3. PRINCIPLE OF OPERATION (CONTROL CIRCUIT)

#### 3-1. Play

- (1) The PLAY lamp goes on and the main motor (DD motor) starts working.
- (2) The rotary solenoid and the sub-motor operate and the gear switch is shortcircuited, thereby keeping the rotary solenoid and the sub-motor in operation.
- (3) With the sub-motor put in operation, the pickup arm is ready to turn. The rotary solenoid determines the position for the pickup arm to stop at.
- (4) When the main gear completes one turn, the gear switch is released, thereby inverting the F.F. which holds the sub-motor and the rotary solenoid and the play stops.
- (5) The main motor and the PLAY lamp keep working.

#### 3-2. Cut

- (1) When the CUT pushbutton being pressed during operation of the record player, the sub-motor starts working and the gear switch keeps the record player in operation.
- (2) With the sub-motor put in operation, the pickup arm starts turning and returns to the rest.
- (3) With the return of the pickup arm to the rest, the rest switch is shortcircuited, thereby inverting the F.F. and the whole operation stops.

#### 3-3. Return

The electric potential of terminal 2 of MPC741C is the standard voltage and when the voltage of terminal 3 exceeds the standard, terminal 6 goes to Hi Level. Whether the voltage of terminal 3 increases or not is decided by the speed of the feed arm entering between the light emitting diode and the phototransistor.

(Adjust voltage with VR1 and VR2 so that the return is performed not when a needle tip is moving in 1 mm-pitch grooves but when it reaches a groove of 3 mm pitch or greater.

With VR1, 0.2 V between pins 8 and 7

With VR2, 0.8 V between pins 8 and 11)

The output produced at terminal 6 is differentiated to turn on only the F.F. which governs the sub-motor, thereby starting the sub-motor, turning the main gear, returning the pickup arm to the rest, short-circuiting the rest switch, inverting the F.F. and finally bringing the whole operation to stop.

#### 3-4. Repeat

Press the REPEAT pushbutton and the REPEAT lamp will go on. Then, once the return is performed as described in 4-3. above, the rotary solenoid operates simultaneously by means of the AND circuit, thereby returning the pickup arm to the rest to stop the DD motor and to turn off the PLAY lamp. At this time, however, the sub-motor is in operation and the end of selector assembly ① is pressed into contact with the rotary solenoid and the lead-in positioned. While the main gear is making one complete turn, the pickup arm turns again, thereby preparing the record player for operation. Then, DD motor starts working and the PLAY lamp goes on.

#### 3-5. Manual operation

When the pickup arm is removed manually from the rest, the rest switch goes on, thereby starting DD motor and turning on the PLAY lamp. The rest switch goes off once the pickup arm is brought back onto the rest.



# WIRING DIAGRAM

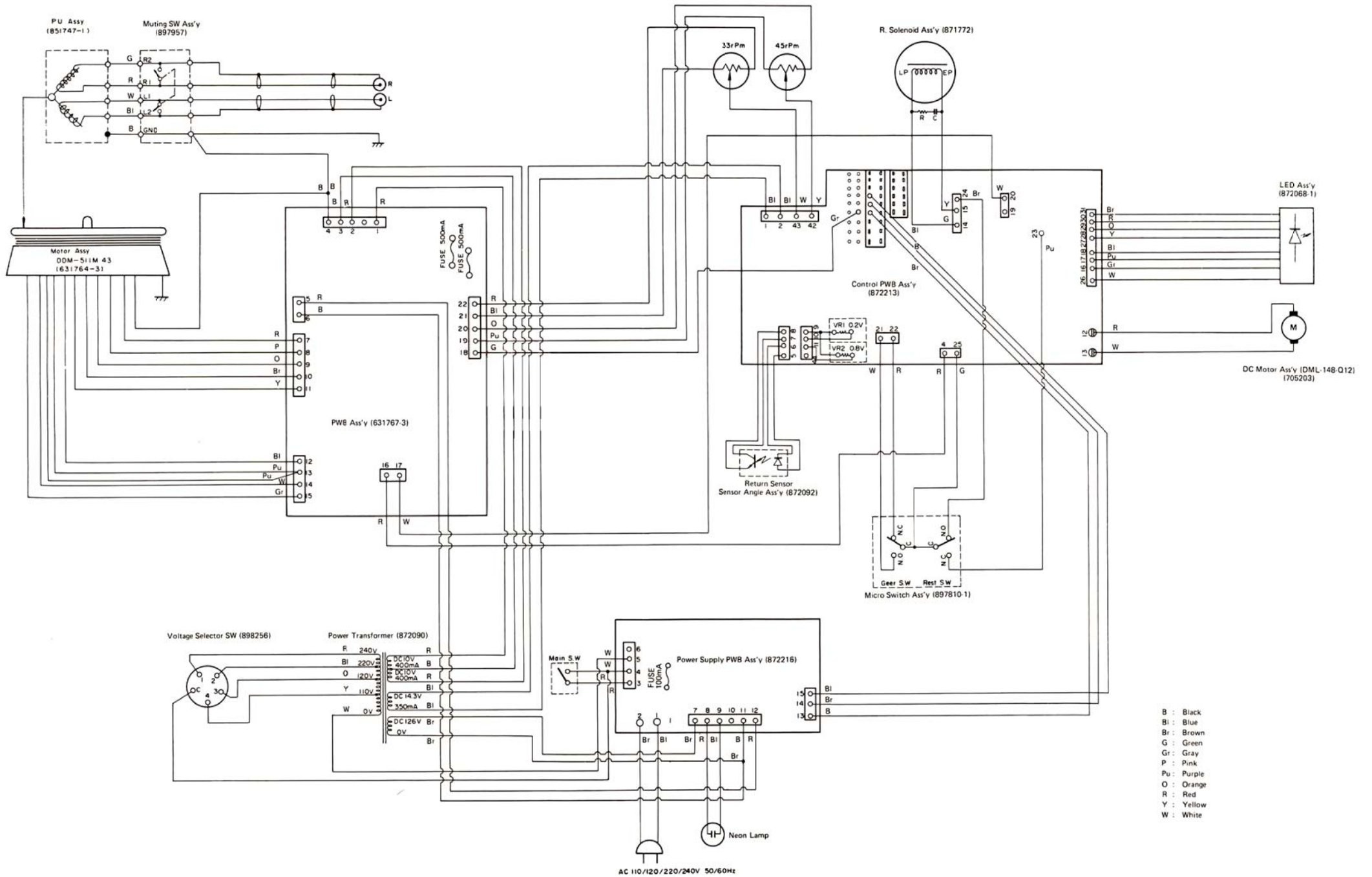

- B : Black
- BI : Blue
- Br : Brown
- G : Green
- Gr : Gray
- P : Pink
- Pu : Purple
- O : Orange
- R : Red
- Y : Yellow
- W : White

# SCHEMATIC DIAGRAM

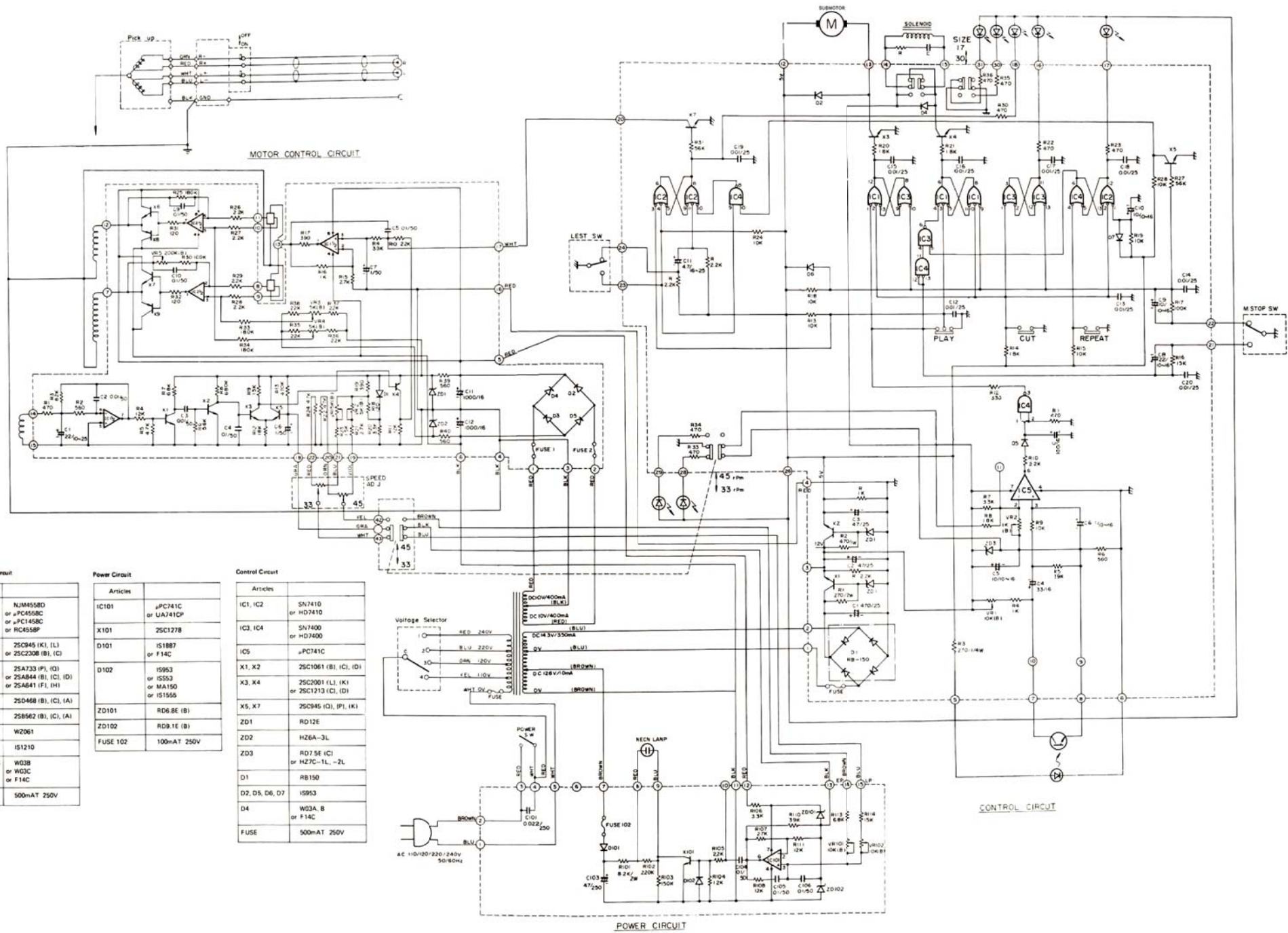

Motor Control Circuit

Articles	
IC1, IC2	NJ4458D or PC458C or PC458C or RC458P
X1, X2, X3, X5	25C945 (K), (L) or 25C2308 (B), (C)
X4	25A733 (P), (Q) or 25A844 (B), (C), (D) or 25A841 (F), (H)
X6, X7	25D468 (B), (C), (A)
X8, X9	25B562 (B), (C), (A)
ZD1, ZD2	W2061
D1	IS1210
D2, D3, D4, D5	W03B or W03C or F14C
FUSE 1, 2	500mA 250V

Power Circuit

Articles	
IC101	μPC741C or UA741CP
X101	25C1278
D101	IS1887 or F14C
D102	IS953 or IS553 or MA150 or IS1555
ZD101	RD6.8E (B)
ZD102	RD9.1E (B)
FUSE 102	100mA 250V

Control Circuit

Articles	
IC1, IC2	SN7410 or HD7410
IC3, IC4	SN7400 or HD7400
IC5	μPC741C
X1, X2	25C1061 (B), (C), (D)
X3, X4	25C2001 (L), (K) or 25C1213 (C), (D)
X5, X7	25C945 (C), (P), (K)
ZD1	RD12E
ZD2	H26A-3L
ZD3	RD7.5E (C) or H27C-1L, -2L
D1	RB150
D2, D5, D6, D7	IS953
D4	W03A, B or F14C
FUSE	500mA 250V

## PWB ASS'Y D.D. MOTOR CONTROL PWB ASS'Y

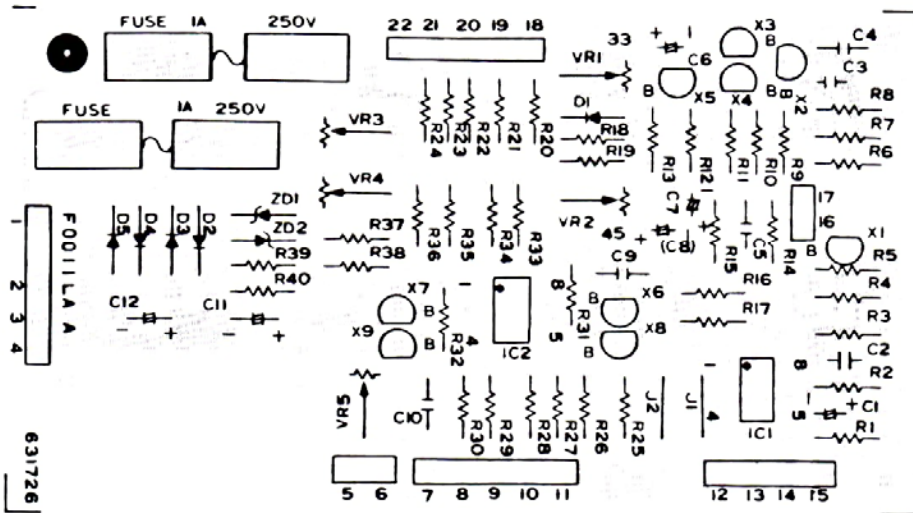

## CONTROL PWB ASS'Y

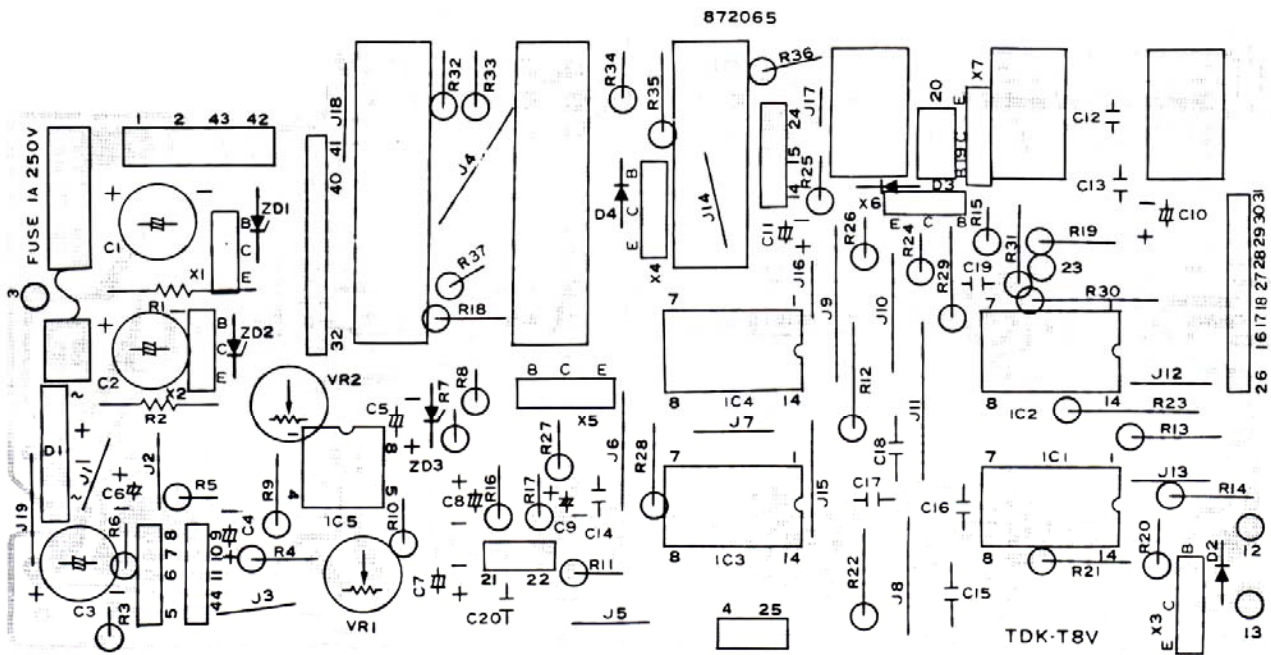

## POWER SUPPLY PWB

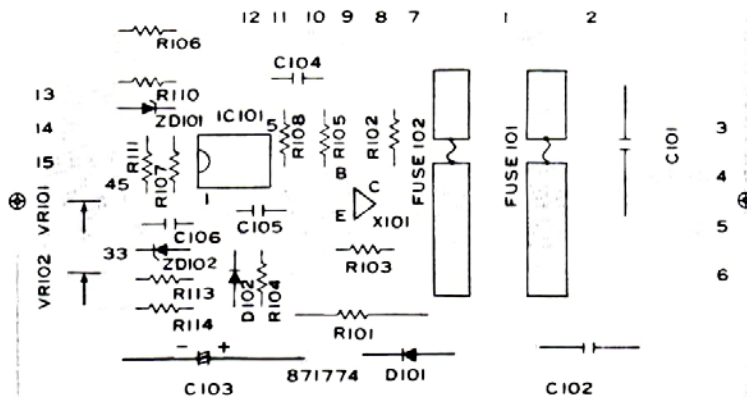

## TABLE OF TROUBLESHOOTING INSTRUCTIONS

SYMPTOM	CAUSE	REMEDY
Platter does not revolve.	<ul style="list-style-type: none"> <li>● Power cable is unplugged.</li> </ul>	<ul style="list-style-type: none"> <li>● Insert power cable firmly into AC outlet.</li> </ul>
No sound.	<ul style="list-style-type: none"> <li>● Connection cords are unplugged from stereo amplifier.</li> </ul>	<ul style="list-style-type: none"> <li>● Connect cords firmly.</li> </ul>
	<ul style="list-style-type: none"> <li>● Headshell is not connected properly.</li> </ul>	<ul style="list-style-type: none"> <li>● Tighten lock nut.</li> </ul>
	<ul style="list-style-type: none"> <li>● FUNCTION switch of stereo amplifier is set to wrong position.</li> </ul>	<ul style="list-style-type: none"> <li>● Set FUNCTION switch to PHONO.</li> </ul>
	<ul style="list-style-type: none"> <li>● TAPE MONITOR switch of stereo amplifier is set to TAPE (or MONITOR).</li> </ul>	<ul style="list-style-type: none"> <li>● Set TAPE MONITOR switch to SOURCE.</li> </ul>
	<ul style="list-style-type: none"> <li>● Lead wires of cartridge are disconnected.</li> </ul>	<ul style="list-style-type: none"> <li>● Connect lead wires firmly to terminal pins of headshell.</li> </ul>
Tempo of reproduced music is strange.	<ul style="list-style-type: none"> <li>● Speed Selector is in wrong position.</li> </ul>	<ul style="list-style-type: none"> <li>● Reset Speed Selector to correct speed for record.</li> </ul>
Sound is noisy.	<ul style="list-style-type: none"> <li>● Dust or dirt on record surface.</li> </ul>	<ul style="list-style-type: none"> <li>● Clean record surface.</li> </ul>
	<ul style="list-style-type: none"> <li>● Dust or dirt on stylus.</li> </ul>	<ul style="list-style-type: none"> <li>● Clean stylus.</li> </ul>
	<ul style="list-style-type: none"> <li>● Tracking force is too light.</li> </ul>	<ul style="list-style-type: none"> <li>● Adjust for proper tracking force.</li> </ul>
	<ul style="list-style-type: none"> <li>● Stylus is worn.</li> </ul>	<ul style="list-style-type: none"> <li>● Replace stylus.</li> </ul>
	<ul style="list-style-type: none"> <li>● Grounding lead is not connected to amplifier.</li> </ul>	<ul style="list-style-type: none"> <li>● Connect grounding lead to amplifier.</li> </ul>
Sound is distorted.	<ul style="list-style-type: none"> <li>● Stylus is worn.</li> </ul>	<ul style="list-style-type: none"> <li>● Replace stylus.</li> </ul>
	<ul style="list-style-type: none"> <li>● Dust or dirt on stylus.</li> </ul>	<ul style="list-style-type: none"> <li>● Clean stylus.</li> </ul>
	<ul style="list-style-type: none"> <li>● Tracking force is too light.</li> </ul>	<ul style="list-style-type: none"> <li>● Adjust for proper tracking force.</li> </ul>
	<ul style="list-style-type: none"> <li>● Overhang adjustment is wrong.</li> </ul>	<ul style="list-style-type: none"> <li>● Re-adjust overhang.</li> </ul>
Loud howling noise.	<ul style="list-style-type: none"> <li>● Howling phenomenon.</li> </ul>	<ul style="list-style-type: none"> <li>● Move turntable away from speaker systems.</li> </ul>
Stylus moves irregularly.	<ul style="list-style-type: none"> <li>● Turntable is not placed on horizontal plane.</li> </ul>	<ul style="list-style-type: none"> <li>● Place turntable on horizontal plane.</li> </ul>
	<ul style="list-style-type: none"> <li>● Tracking force is too light, and Anti-Skate Control is not adjusted properly.</li> </ul>	<ul style="list-style-type: none"> <li>● Re-adjust tracking force and Anti-Skate Control.</li> </ul>
Auto-play does not work.	<ul style="list-style-type: none"> <li>● Tonearm is clamped on arm rest.</li> </ul>	<ul style="list-style-type: none"> <li>● Release clasper of arm rest.</li> </ul>
Auto-return and autocut do not work, and tonearm does not descend at Auto-Play.	<ul style="list-style-type: none"> <li>● Cueing Lever is not down</li> </ul>	<ul style="list-style-type: none"> <li>● Pull Cueing Lever down.</li> </ul>
Stylus does not come on to correct lead-in groove.	<ul style="list-style-type: none"> <li>● Disc Size Selector is in wrong position.</li> </ul>	<ul style="list-style-type: none"> <li>● Reset Disc Size Selector to correct size of record.</li> </ul>

# EXPLODED VIEW

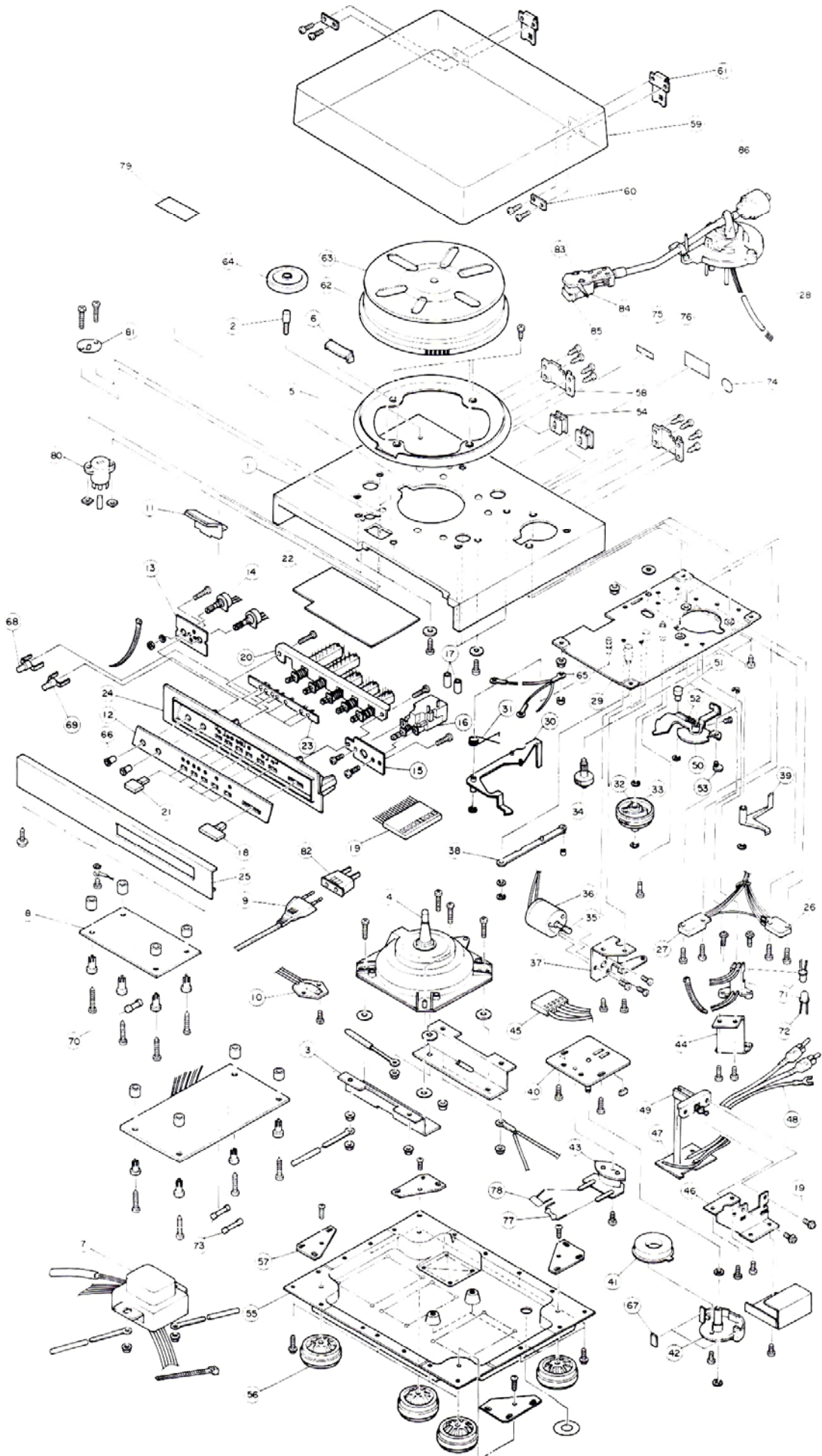

# REPLACEMENT PARTS LIST

FOR  
**NEC**  
 TURNTABLE



## AUP-7300E

SYMBOL NO.	PART NO.	FACTORY STOCK NO.	DESCRIPTION	QTY	REMARKS
1	18983731	847185-1	Cabinet Case	1	
2	18283271	890097	Adaptor Spindle	1	
3	18983741	897114	Motor Angle	2	
4	18983751	631784-3	D.D Motor Ass'y	1	
5	18981811	847148	T.T Ring	1	
6	18981821	897854	Lamp Cover (1)	1	
7	18983761	872090	Power Trans. Ass'y	1	
8	18983771	872216	Power Supply PWB Ass'y	1	
9	18982681	895617	Main Cord Ass'y	1	
10	18981861	897985	Neon Lamp Ass'y	1	
11	18981871	897855	Lamp Cover	1	
12	18983781	872057-3	Name Plate, Operation	1	
13	18983791	897151	VR Angle	1	
14	18983801	703062	Variable Resistor	1	
15	18983811	897950	P.S.W Angle	1	
16	18982701	872069	Power Switch	1	
17	18983821	702233-3	UL Tube	7	
18	18983831	897856	P.S.W Knob	1	
19	18983841	898069-1	Connector Ass'y	1	
20	18981931	872015-1	Push Switch	1	
21	18983851	897857	Knob, Operation	5	
22	18983861	872213	Control PWB Ass'y	1	
23	18983871	872067	Bracket, LED Mounting	1	
24	18983881	851719-2	Operation Panel	1	
25	18983891	851720-2	Front Panel	1	
26	18981981	871418	Micro Switch	1	
27	18981991	870560	Micro Switch	1	
28	18982741	851747-1	PU Ass'y	1	
29	18983901	871771-1	Mecha Chassis	1	
30	18983911	897288	Selector Ass'y	1	

SYMBOL NO.	PART NO.	FACTORY STOCK NO.	DESCRIPTION	QTY	REMARKS
31	18983921	896358-1	Selector, Spring	1	
32	18982051	896361	Main Gear (2)	1	
33	18982061	851326	Main Gear (1)	1	
34	18982071	896243	Gear (1)	1	
35	18982081	896244	Gear (2)	1	
36	18982091	705203	D.C. Motor	1	
37	18983931	896240	Gear, Bracket	1	
38	18983941	896250	Rotation Plate Ass'y	1	
39	18983951	896238-1	Switch Arm	1	
40	18983961	897301	Sub-chassis Ass'y	1	
41	18983971	897378	Magnet Ass'y	1	
42	18983981	871668	Selector Cam	1	
43	18983991	986246	Sensor Holder	1	
44	18984001	897755-1	Sensor Angle	1	
45	18984011	898024-1	Connector Ass'y	1	
46	18984021	897952	M.S.W. Angle	1	
47	18982751	897954	PH PWB	1	
48	18982181	893699-5	Shield Wire Ass'y	1	
49	18982191	897944	Push Switch	1	
50	18984031	897953	Supply Arm Ass'y (1)	1	
51	18984041	896598-1	Eccentric Pin	1	
52	18982221	801554	Arm, Spring	1	
53	18982231	891066-2	Eccentric Pin (2)	1	
54	18984051	871026	Cord Bushing (2)	2	
55	18982261	847184	Bottom Cover	1	
56	18982271	895232	Foot	4	
57	18984061	886867	Bracket, Foot	4	
58	18984071	895259	Lock Plate	2	
59	18982761	851097-5	Dust Cover	1	
60	18982291	895231	Plate	2	
61	18982301	895215	Hinge Ass'y	2	
62	18982311	620058	Turntable	1	
63	18982321	872064	T.T. Sheet	1	
64	18281631	890876	Adaptor	1	
65	18984081	893442-1	Earth Wire Ass'y	1	
66	18984091	897864	Knob, Volume	1	
67	18982781	897842	Damper	2	
68	18982351	896427-1	Diode	2	
69	18982361	896427-3	Diode	5	
70	18984101	893791-7	Fuse	1	

SYMBOL NO.	PART NO.	FACTORY STOCK NO.	DESCRIPTION	QTY	REMARKS
71	18982401	896360	Photo Diode	1	
72	1898411	896359	Photo Diode	1	
73	1898412	892174	Fuse	1	
74	18753101	895571	Passed Label	1	
75	18286691	892031	Serial Number Label	1	
76	18984131	898246-1	Name Plate	1	
77	18982821		Resistor 22Ω ¼W	1	
78	18982831		Capacitor 0.1μF 50V	1	
79	18982841	895874	Caution Label	1	
80	18982861	898256	Voltage Selector	1	
81	18982871	898257	Voltage Selector Cover	1	
82	18982881	895923	2P Adaptor Plug	1	
83	18982011	851749	Headshell	1	
84	18983471	851749	Cartridge	1	
85	18984141	851749	Stylus	1	
86	18982031	851749	Main Weight	1	
	78911651		Instruction Book		