

STEREO
POWER AMPLIFIER
ALPHA II

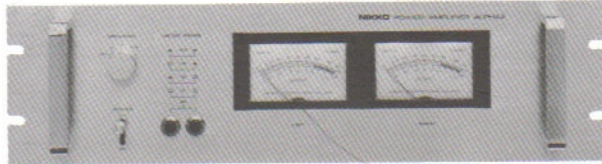

SERVICE MANUAL

TYPE AND VOLTAGE

W-TYPE UL and CSA type	120V
E-TYPE europe standard (universal) type	220/240V
N-TYPE DEMKO and SEMKO type	
D-TYPE DIN type	

NIKKO

OPERATING PARTS

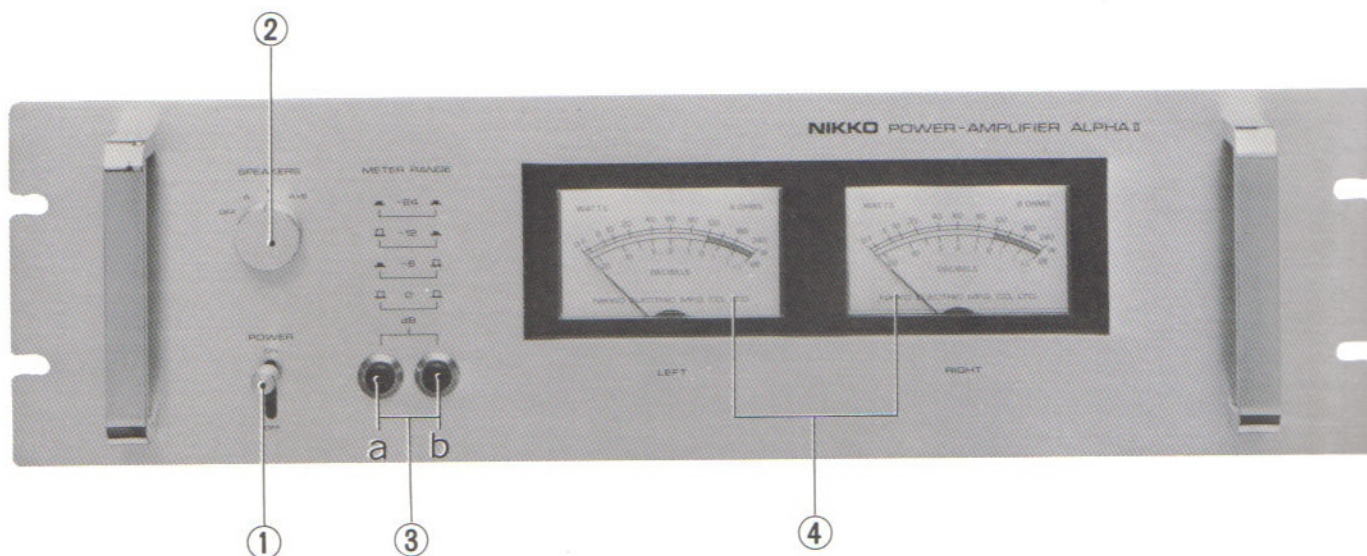

1. POWER

Set the power switch to the ON position and the power is turned on. The power meters will be illuminated, indicating that the power is on. The unit will become active 3 to 6 seconds later because of the employment of a protective circuit and relay.

2. SPEAKERS

This switch is used to select speakers connected to the A and B speaker terminals on the rear panel. When the switch is set to the A+B position, both speakers connected to the A and B terminals are operated at the same time. Speakers may be connected to the A or B terminals only, if desired. At the OFF position of the switch, no speakers will operate.

3. METER RANGE

These two pushbutton switches are used to select the sensitivity of the power meters in 4 steps.

With the switches ('a' and 'b') in the released position (\square), the power meters will indicate 0dB when the output power of a single tone sign-wave signal reaches 120W (at 8-ohm load).

By pressing the button switches as shown on the front panel, the 0dB position on the power meters represents 30W for -6dB setting, 7.6W for -12dB setting and 0.48W for -24dB setting, respectively.

4. POWER METER

The power meters indicate the levels of left and right channel output power in dB. Power levels can be read directly on the meters with the meter range switches (3) set in the 0dB (released) position.

TERMINALS ON REAR PANEL

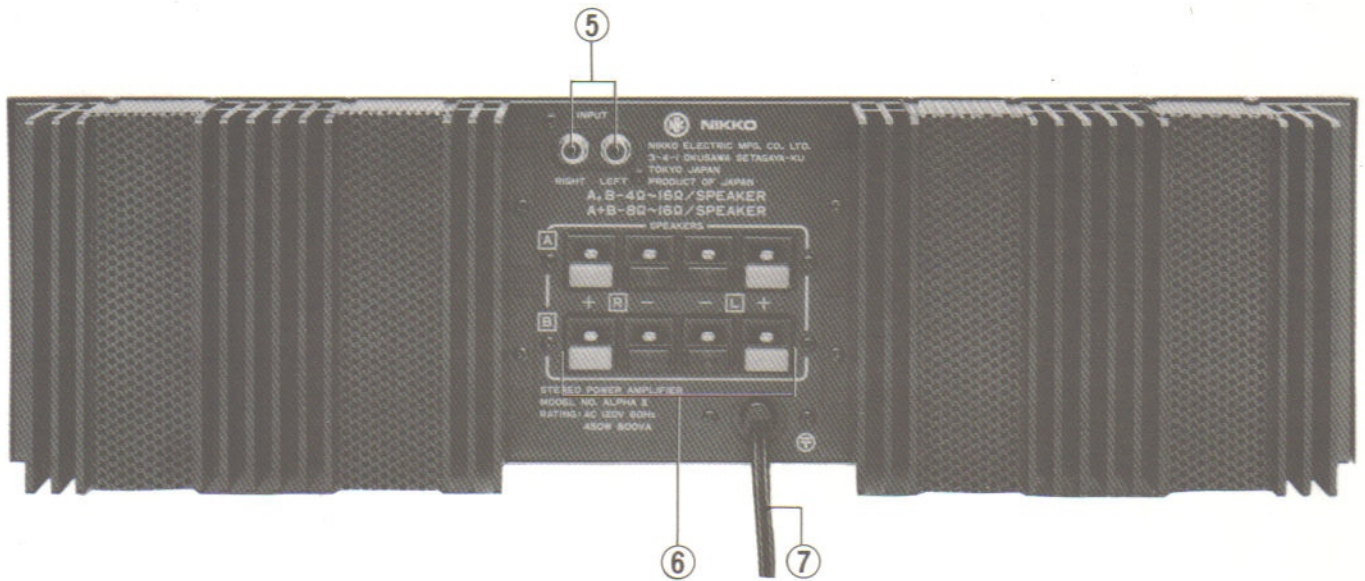

5. INPUT Terminals

Connect the input of the preamplifier using a pin-plug cord.

6. SPEAKERS Terminals

The unit has provision for connecting 2 sets of speaker systems. Connect your right speakers to right speaker terminals and left speakers to left speaker terminals. Each speaker terminal is color coded to indicate polarity; the red mark indicates "positive" and the black one "negative". Use these marks for correct connections of your speakers. When connecting, make sure that the bare portions of connecting cords are not in contact with any metallic parts such as the panel of the unit.

* Your speakers must have more than 4 ohms of impedance. If 2 sets of speaker systems are connected, each speaker must have at least 8-ohm impedance.

* Use connecting cords having sufficient current capacity. Connect the cords firmly. If the cords have insufficient capacity or they are loosely connected, the result is deterioration of sound quality, overheating or breaks in cords.

7. AC Power Cord

Connect the AC power cord to your convenient wall-outlet. The power switch must be turned to OFF before connecting. The unit is rated at 450W of power consumption. If it becomes necessary to use an extension power cord, it must be the same in size as the AC power cord, or larger. When the power cord is connected to the AC outlet provided on the preamplifier, the power cord of the preamplifier must be connected to a wall-outlet having sufficient capacity.

CONTENTS

SPECIFICATIONS (W-TYPE, E-TYPE, N-TYPE)	5
SPECIFICATIONS (D-TYPE)	5
INSTRUMENT DISASSEMBLY	6
OVERALL SCHEMATIC DIAGRAM AND CIRCUIT BOARDS (W-TYPE, E-TYPE, N-TYPE)	8
OVERALL SCHEMATIC DIAGRAM AND CIRCUIT BOARDS (D-TYPE)	11
PARTS LOCATION	14
PARTS LIST	15
CHASSIS ALIGNMENT	19
SEMICONDUCTORS DATA	20

SPECIFICATIONS (W-TYPE, E-TYPE, N-TYPE)

	UNIT	NOMINAL	LIMIT
Continuous Power Output per channel 8 ohm loads:			
15Hz-20KHz @ 0.03% THD	.watts.	.120.	.110
1KHz @ 0.03% THD	.watts.	.130.	.110
TH Distortion, 8 ohm loads, 15Hz-20KHz:			
@ Continuous Power Output	%		< 0.03
@ 1 watt Power Output	%		< 0.02
IM Distortion, 8 ohm loads:			
@ Continuous Power Output	%		< 0.03
@ 1 watt Power Output	%		< 0.02
IHF Power Bandwidth, 8 ohm loads	.Hz-KHz	.5 - 60.	.5 - 50
Damping Factor, 8 ohm loads, 1KHz.		.80	.70
Frequency Response, 8 ohm loads:			
@ 1 watt Power Output	.dB@Hz-KHZ.		+ 0, -2 @10 - 100
Input Sensitivity	.mV	.1000.	.1000 ± 2dB
Signal-to-Noise Ratio, IHF	.dB	.105.	.100
Residual Hum & Noise, 8 ohm load.	.mV	.0.2	.0.25
Idling Current.	.mA.	.100.	.60 - 150
Midpoint Voltage	.mV	.0	± 50
Power Switch Muting Delay Time	.second.	.4	.4 ± 2

SPECIFICATIONS (D - TYPE)

	UNIT	NOMINAL	LIMIT
Continuous Power Output per channel 4 ohm loads:			
15Hz-20KHz @ 0.08% THD	.watts.	.130.	.120
1KHz @ 1% THD	.watts.	.150.	.140
TH Distortion, 4 ohm loads, 15Hz-20KHz:			
@ Continuous Power Output	%		< 0.08
@ 1 watt Power Output	%		< 0.05
IM Distortion, 4 ohm loads:			
@ Continuous Power Output	%		< 0.08
@ 1 watt Power Output	%		< 0.05
Power Bandwidth, 4 ohm loads	.Hz-KHz	.5 - 50.	.10 - 30
Damping Factor, 4 ohm loads, 1KHz.		.45	.40
Frequency Response, 4 ohm loads:			
@ 1 watt Power Output	.dB@Hz-KHZ.		+ 0, -3 @ 5 - 80
Input Sensitivity	.mV	.800.	.800 ± 2dB
Signal-to-Noise Ratio, DIN	.dB	.85	.80
Residual Hum & Noise, 4 ohm load.	.mV	.0.2	.0.25
Idling Current.	.mA.	.100.	.60 - 150
Midpoint Voltage	.mV	.0	± 50
Power Switch Muting Delay Time	.second.	.4	.4 ± 2

INSTRUMENT DISASSEMBLY AND PARTS REPLACEMENT

NOTE: Numbers of three figures put a (○) around on Photo 1 thru 7 relate to "KEY NO." marked with a (★) on parts list.

CABINET TOP STEEL COVER

Remove four (4) tapping screws (116) (1 thru 4), remove four (4) tapping screws (114) (5 thru 8), lift steel cover (113) up and out of the instrument (Photo 1).

Do not lose these screws and four (4) washers. To reassemble, reverse above procedure.

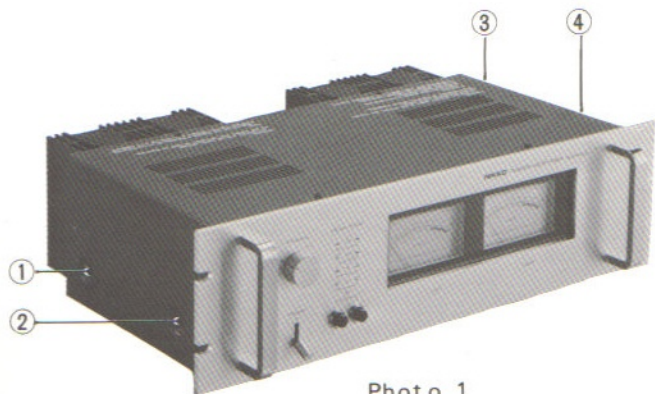

Photo 1

BOTTOM PLATE REMOVAL

Remove twelve (12) tapping screws (118) from the bottom of the cabinet, lift Bottom Plate (117) up and out of the instrument.

To reassemble, reverse above procedure.

FRONT PANEL REMOVAL

1. Using hexagonal wrench, remove SPEAKERS knob.
2. Remove POWER knob by pulling it out Front Panel.
3. Remove six (6) nuts (1 thru 6), lift the Front Panel out of the instrument (Photo 2).
4. To reassemble, reverse above procedure.

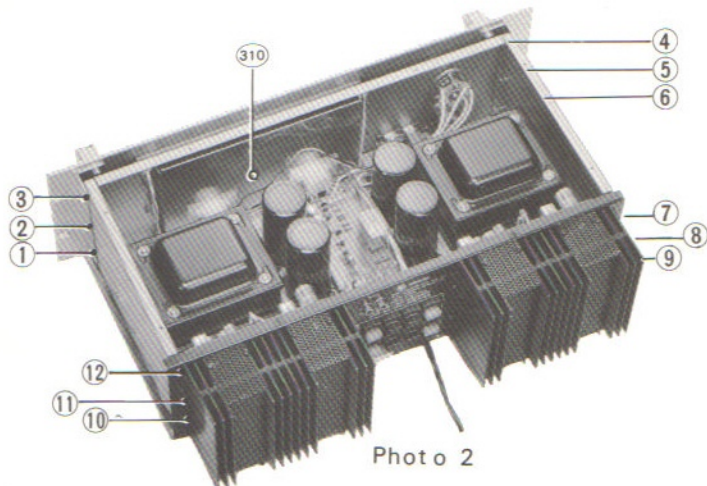

Photo 2

METER REMOVAL

1. Two meters are held by "meter holder". To remove the meter holder, remove six (6) tapping screws (1 thru 3, 8 thru 10) (Photo 3). Then, while moving Front Plate slightly, remove four (4) tapping screws (5,6,12,13) from the rear of the Front Plate (Photo 3). Lift the meter holder up and out of the Front Plate.
2. The meters are now free to be pulled off. Disconnect cables connecting to the meters.
3. To reassemble, reverse above procedure

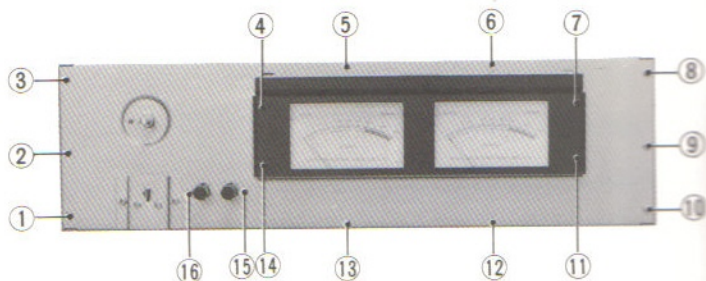

Photo 3

LAMP REPLACEMENT AND LAMP CIRCUIT BOARD REMOVAL

1. Remove "meter holder" as shown in the procedure 1 of "Meter Removal".
2. Remove four (4) tapping screws (4,7,11,14), lift Back Ground Panel out of Front Plate (Photo 3).
3. To replace lamps, use soldering iron.
4. Push the center of "push rivet" from the rear of front panel by small screwdriver (See Figure 1), then pull three (3) push rivets (1 thru 3) (Photo 4).
5. Disconnect cables, lift the Lamp Circuit Board up and out of the Front Panel.
6. To reassemble, reverse above procedure.



PUSH RIVET (314)

Fig. 1

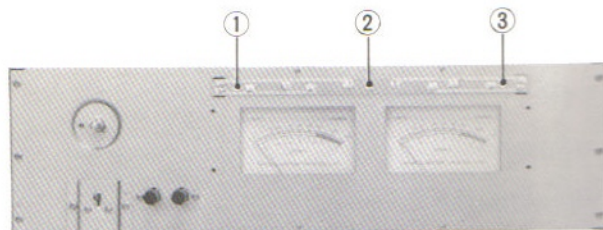

Photo 4

METER SWITCH CIRCUIT BOARD REMOVAL

Disconnect all cables. Remove two (2) tapping screws (15,16) (Photo 3). Pull Circuit Board back, lift up and out of chassis.

To reassemble, reverse above procedure.

REGULATOR CIRCUIT BOARD REMOVAL AND PART REPLACEMENT

1. To replace regulator circuit's parts, dismount Regulator Circuit Board from "PCB Support Pin". Then lift the front of the Regulator Circuit Board as upward as possible for service as indicated in Photo 5.
2. To remove the Regulator Circuit Board, disconnect all cables, lift the Regulator Circuit Board up and out of chassis.
3. To reassemble, reverse above procedure.

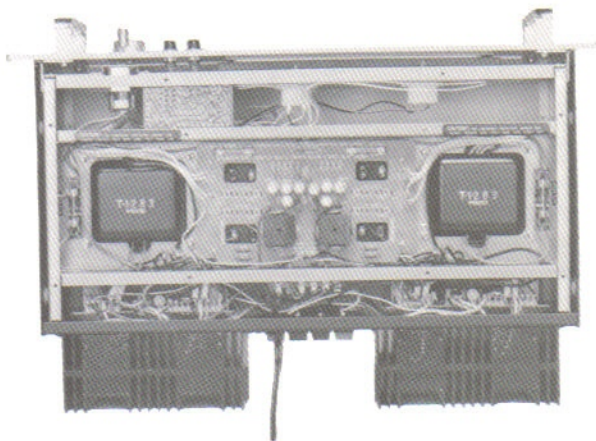

Photo 5

PROTECTOR CIRCUIT BOARD REMOVAL AND PARTS REPLACEMENT

1. To replace protector circuit's parts, dismount Protector Circuit Board from "PCB Support Pin". Then, lift the Protector Circuit Board up for service.
2. To remove the Protector Circuit Board, disconnect all cables, lift the Protector Circuit Board up and out of chassis.
3. To reassemble, reverse above procedure.

POWER TRANSISTOR REMOVAL (Q2R only)

1. To remove Heatsink Cover, remove four (4) tapping screws (1 thru 4) (Photo 6).
2. To remove Power Transistor, remove two (2) screws (5,6) (Photo 6). Pull the Power Transistor out Power Transistor socket.
3. To reassemble, reverse above procedure.



Photo 6

PARTS REPLACEMENT

1. To replace main amp circuit's parts, it is necessary to remove six (6) tapping screws (7 thru 12) (Photo 2) and incline Back Plate Assembly as indicated in Photo 7.

WARNING: Do not pull the Back Plate Assembly back strongly, if so, circuit boards may be broken or cables are cut.

2. Dismount the Main Amp Circuit Board from "PCB Support Pin", lift the top of the Main Amp Circuit Board forward for service as indicated in Photo 7.

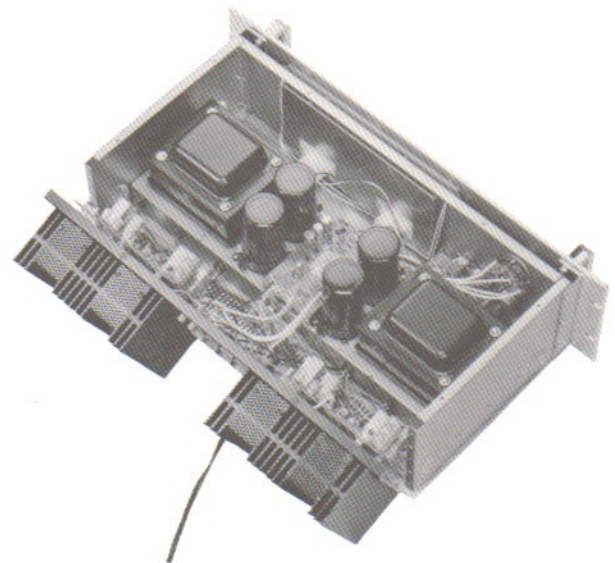
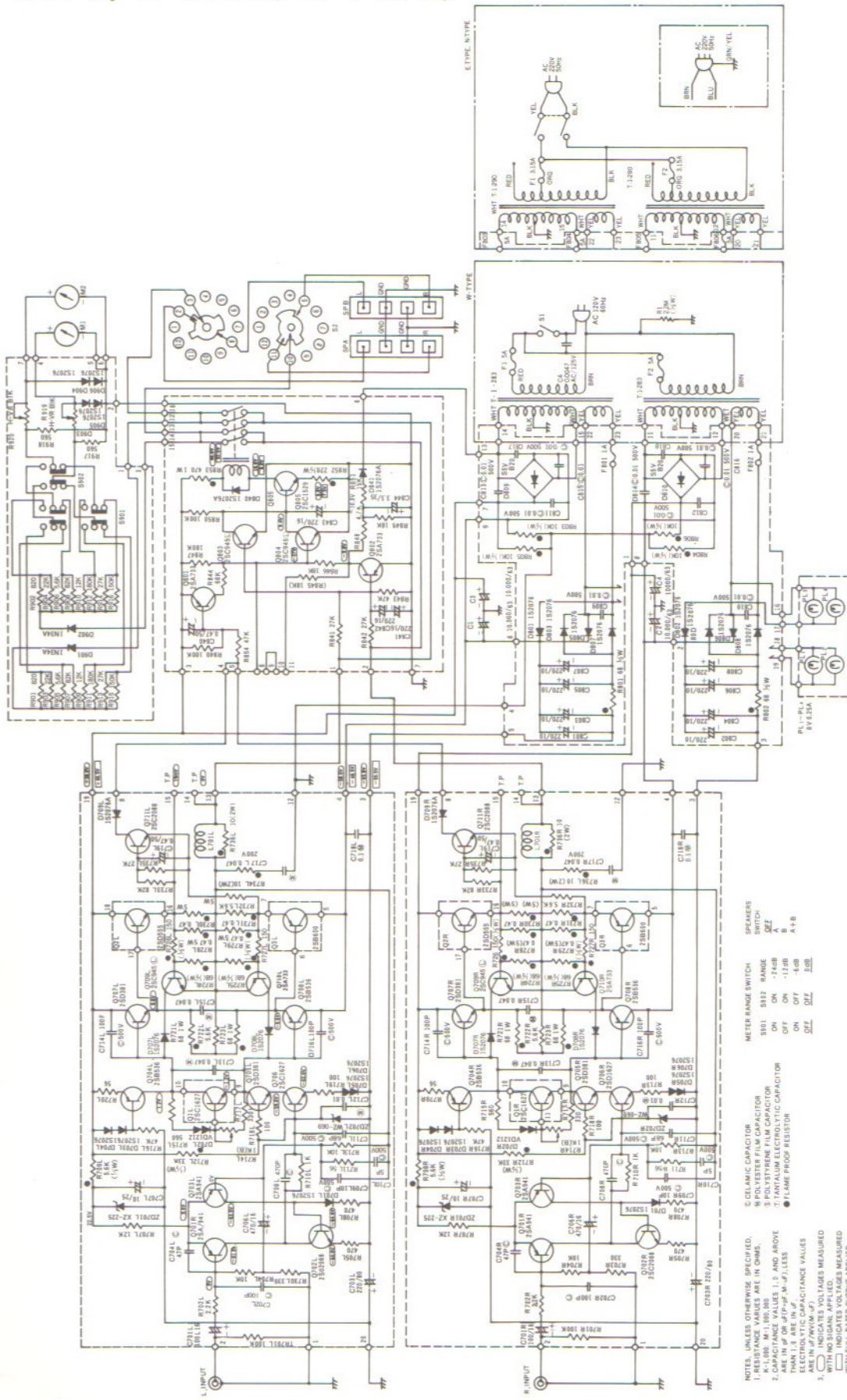

Photo 7

OVERALL SCHEMATIC DIAGRAM AND CIRCUIT BOARDS (W-TYPE, E-TYPE, N-TYPE)

OVERALL SCHEMATIC DIAGRAM



METER RANGE SWITCH

SWITCH	5851	5852	RANGE
ON	ON	ON	-24dB
OFF	OFF	OFF	-12dB
ON	OFF	ON	A
OFF	ON	OFF	A+B

- 1. RESISTOR CAPACITOR
- 2. POLYESTER FILM CAPACITOR
- 3. TANTALUM ELECTROLYTIC CAPACITOR
- 4. FLAME PROOF RESISTOR

NOTES: UNLESS OTHERWISE SPECIFIED, RESISTANCE VALUES ARE IN OHMS, CAPACITANCE VALUES IN P.F. UNLESS INDICATED OTHERWISE. VOLTAGES MEASURED WITH FULL RATED OUTPUT APPLIED. COMPONENTS ARE SUBJECT TO CHANGE WITHOUT NOTICE.

- ① To MAIN AMP C.B. (L) ⑬
- ② To MAIN AMP C.B. (R) ⑬
- ③ To C3+
- ④ To MAIN AMP C.B. (L) ⑧
- ⑤ To MAIN AMP C.B. (R) ⑧
- ⑥ To REGULATOR C.B. ⑬
- ⑦ To EARTH LUG (L)
- ⑧ To THERMOSTAT
- ⑨
- ⑩ To THERMOSTAT
- ⑪ To SPEAKER SWITCH
- ⑫ To SPEAKER SWITCH
- ⑬ To METER SWITCH
- ⑭ To METER SWITCH
- ⑮ To METER SWITCH
- ⑯ To METER SWITCH
- ⑰ To THERMOSTAT

- ① To PROTECTOR C.B. ⑬
- ② To PROTECTOR C.B. ⑬
- ③ To PROTECTOR C.B. ⑬
- ④ To METER (L) ⊕
- ⑤ To METER (L) ⊖
- ⑥ To METER (R) ⊕
- ⑦ To METER (R) ⊕

MAIN AMP CIRCUIT BOARD (BOTTOM VIEW)

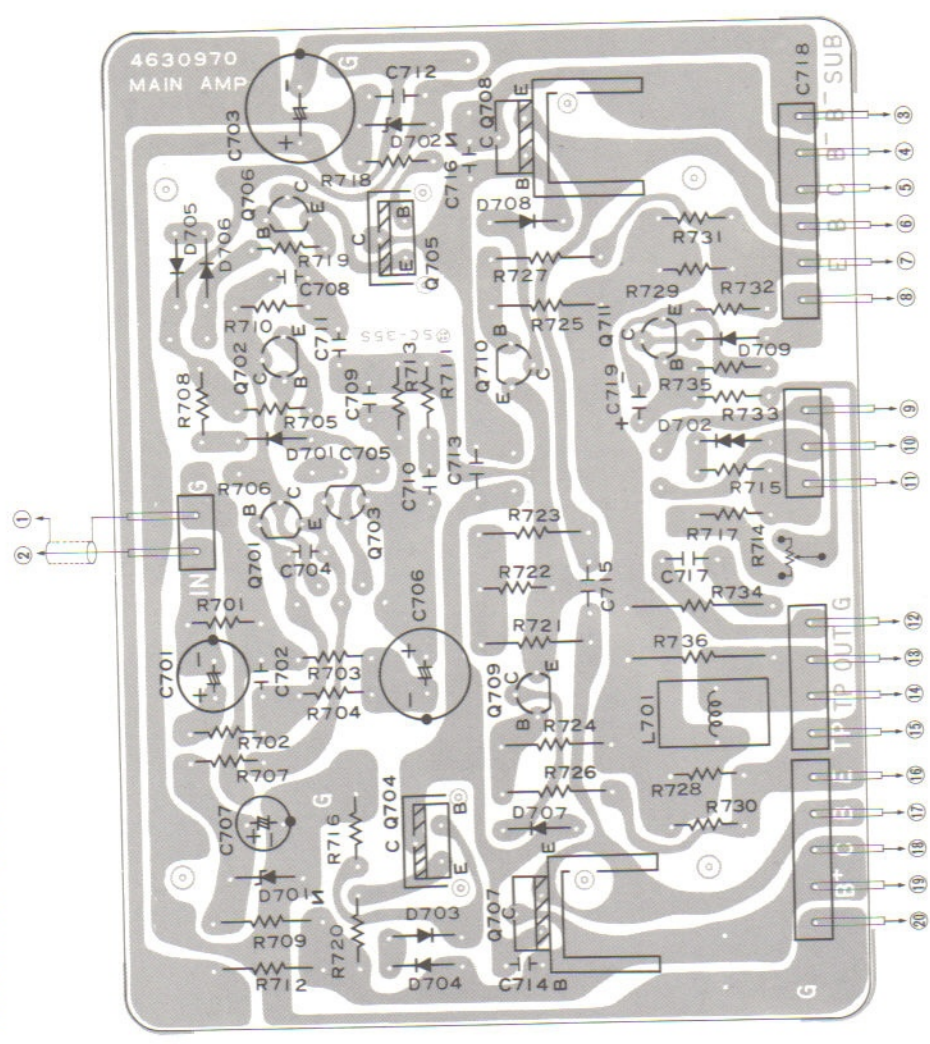

- L-CHANNEL
 - ① To INPUT TERMINAL L (GROUND)
 - ② To INPUT TERMINAL L
 - ③ To REGULATOR C.B. ⑤
 - ④ To C1-
 - ⑤ To Q3L(2SB600) C
 - ⑥ To Q3L(2SB600) B
 - ⑦ To Q3L(2SB600) E
 - ⑧ To PROTECTOR C.B. ④
 - ⑨ To Q1L(2SC1627) E
 - ⑩ To Q1L(2SC1627) C
 - ⑪ To Q1L(2SC1627) B
 - ⑫ To EARTH LUG
 - ⑬ To PROTECTOR C.B. ①
 - ⑭ To TEST POINT (FOR IDLING CURRENT ADJUSTMENT)
 - ⑮ To Q2L(2SD555) E
 - ⑯ To Q2L(2SD555) B
 - ⑰ To Q2L(2SD555) C
 - ⑱ To C3+
 - ⑳ To EARTH LUG
-
- R-CHANNEL
 - ① To INPUT TERMINAL R (GROUND)
 - ② To INPUT TERMINAL R
 - ③ To REGULATOR C.B. ③
 - ④ To C2-
 - ⑤ To Q3R(2SB600) C
 - ⑥ To Q3R(2SB600) B
 - ⑦ To Q3R(2SB600) E
 - ⑧ To PROTECTOR C.B. ⑤
 - ⑨ To Q1R(2SC1627) E
 - ⑩ To Q1R(2SC1627) C
 - ⑪ To Q1R(2SC1627) B
 - ⑫ To EARTH LUG
 - ⑬ To PROTECTOR C.B. ②
 - ⑭ To TEST POINT (FOR IDLING CURRENT ADJUSTMENT)
 - ⑮ To Q2L(2SD555) E
 - ⑯ To Q2L(2SD555) B
 - ⑰ To Q2L(2SD555) C
 - ⑱ To C4+
 - ⑳ To EARTH LUG

OVERALL SCHEMATIC DIAGRAM AND CIRCUIT BOARDS (D-TYPE)

OVERALL SCHEMATIC DIAGRAM

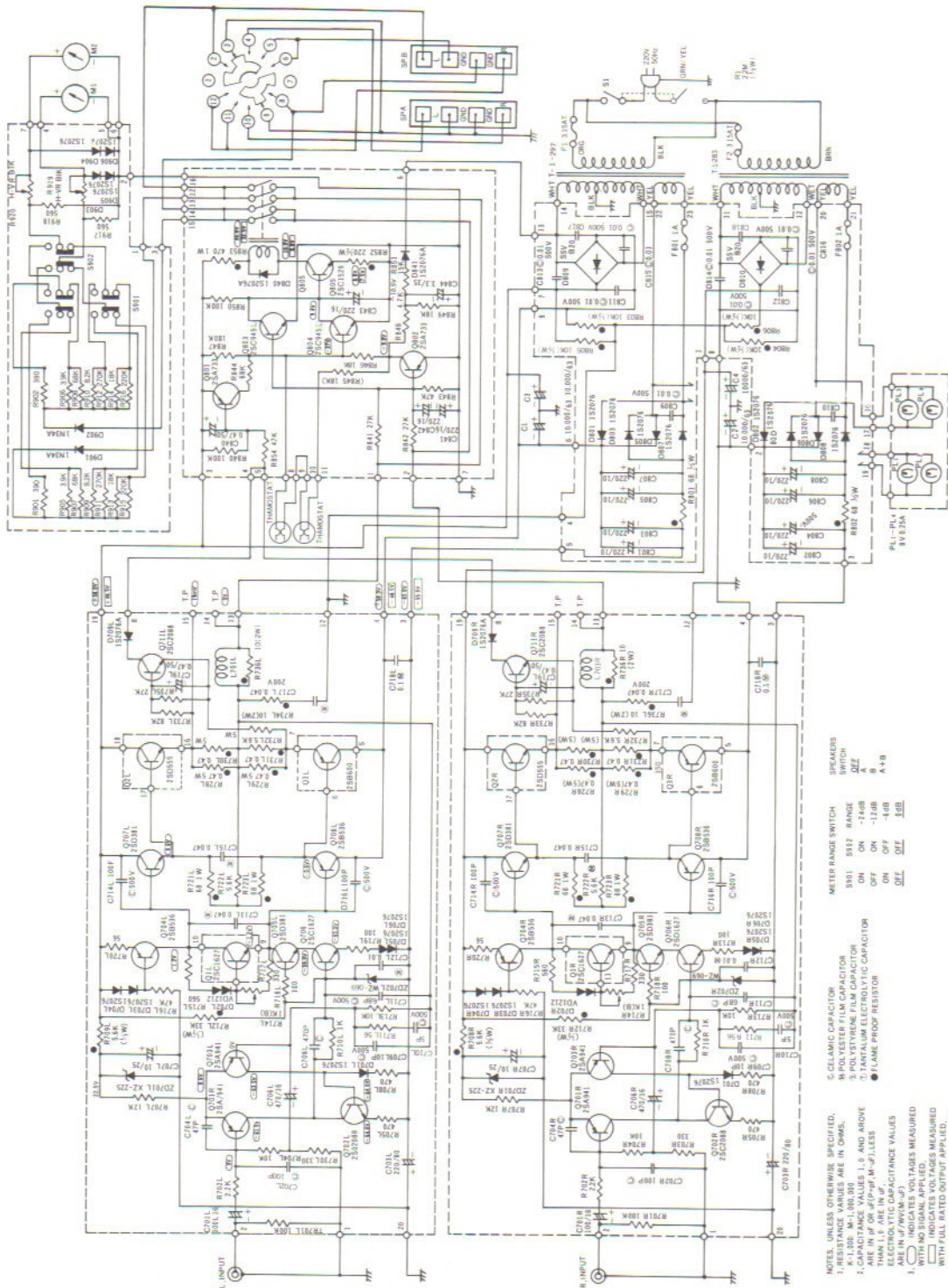

- NOTES, UNLESS OTHERWISE SPECIFIED:
1. ALL DIMENSIONS ARE IN DIMS.
 2. CAPACITANCE VALUES 1.0 AND ABOVE ARE IN μ F OR μ F-PF, M- μ F/LESS ELECTROLYTIC CAPACITANCE VALUES ARE IN μ F/WMV-PF.
 3. DIMENSIONS INDICATES VOLTAGES MEASURED WITH FULL RATED OUTPUT APPLIED. EXCEPT FOR DIMS AND GROUND ARE SUBJECT TO CHANGE WITHOUT NOTICE.
- C CERAMIC CAPACITOR
 F POLYESTER FILM CAPACITOR
 M MICA CAPACITOR
 T TANTALUM ELECTROLYTIC CAPACITOR
 R FLAME PROOF RESISTOR
- METER RANGE SWITCH
 S911 S912 RANGE
 ON ON -24dB
 OFF OFF -12dB
 ON OFF -6dB
 OFF OFF -3dB
- SPEAKERS
 SWITCH
 A-ZZ
 B
 A-B

REGURATOR CIRCUIT BOARD (BOTTOM VIEW)

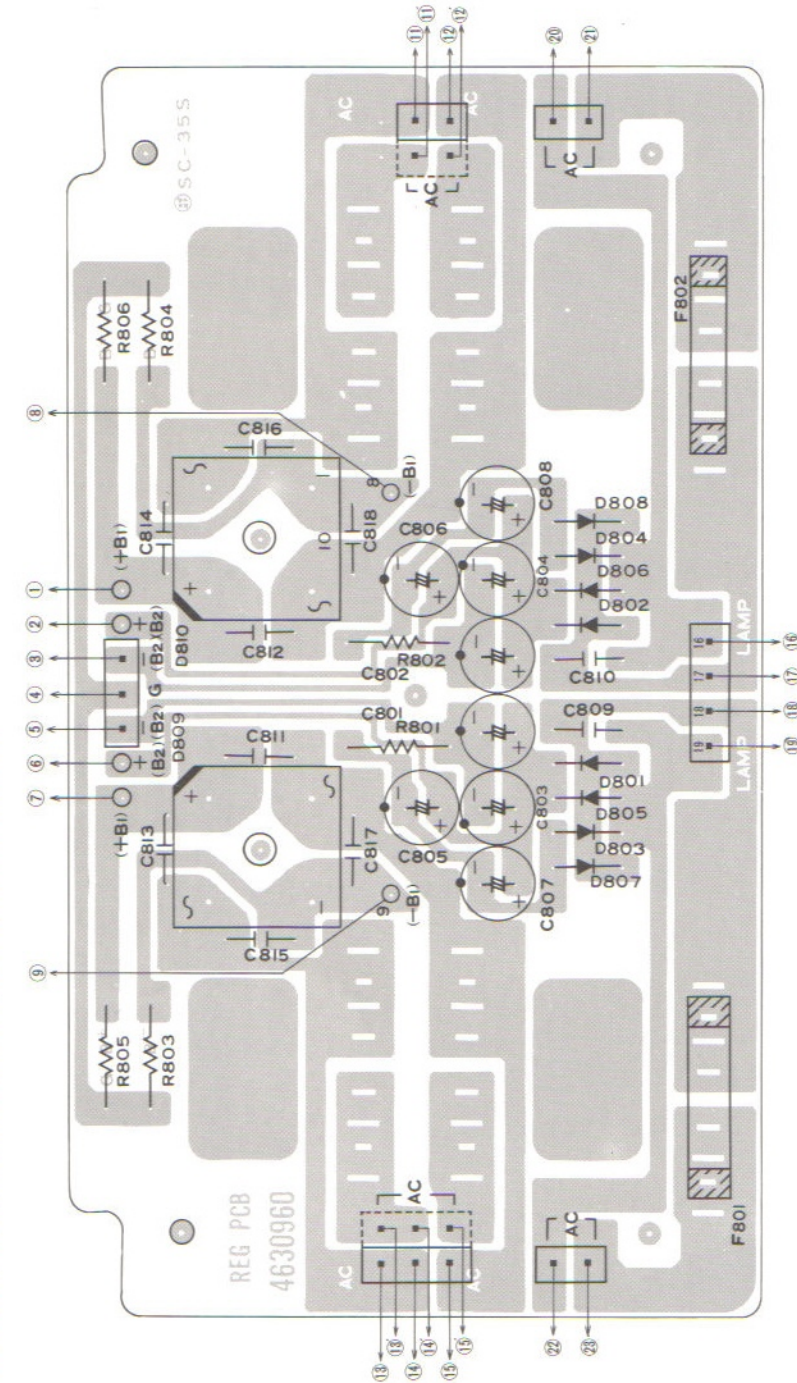

- ① To C4+
- ② To C2-
- ③ To MAIN AMP C.B. (R)③
- ④ To R-CH EARTH LUG
- ⑤ To MAIN AMP C.B. (L)③
- ⑥ To C1-
- ⑦ To C3+
- ⑧ To C2-
- ⑨ To C1-
- ⑩
- ⑪
- ⑫ To R-CH P.T. (WHT)
- ⑬ To PROTECTOR C.B.
- ⑭ To L-CH P.T. (WHT)
- ⑮ To R-CH LAMP
- ⑯ To R-CH P.T. (YEL)
- ⑰
- ⑱
- ⑲
- ⑳ To L-CH P.T. (YEL)
- ㉑
- ㉒
- ㉓

PROTECTOR CIRCUIT BOARD (BOTTOM VIEW)

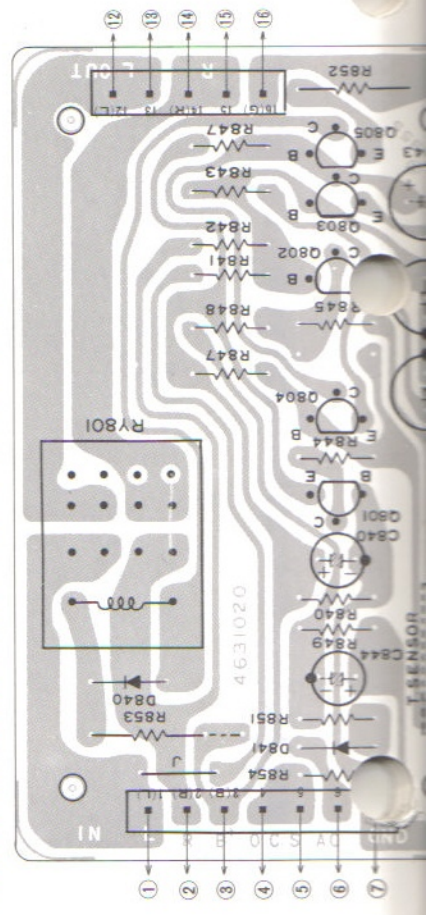

METER SWITCH CIRCUIT BOARD (BOTTOM VIEW)

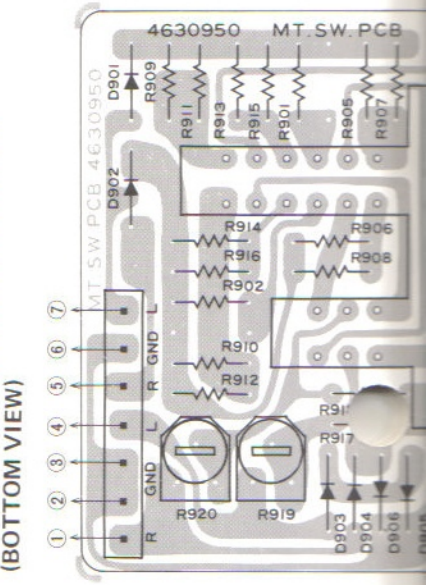

- ① To MAIN AMP C.B. (L) ⑬
- ② To MAIN AMP C.B. (R) ⑬
- ③ To C3⊕
- ④ To MAIN AMP C.B. (L) ⑧
- ⑤ To MAIN AMP C.B. (R) ⑧
- ⑥ To REGULATOR C.B. ⑬
- ⑦ To EARTH LUG (L)
- ⑧ To THERMOSTAT
- ⑨
- ⑩ To THERMOSTAT
- ⑪ To SPEAKER SWITCH
- ⑫ To METER SWITCH
- ⑬ C.B. ①
- ⑭ To SPEAKER SWITCH
- ⑮ To METER SWITCH
- ⑯ C.B. ③
- ⑰ To METER SWITCH
- ⑱ C.B. ②

- ① To PROTECTOR C.B. ⑬
- ② To PROTECTOR C.B. ⑬
- ③ To PROTECTOR C.B. ⑬
- ④ To METER (L)⊕
- ⑤ To METER (L)⊖
- ⑥ To METER (R)⊕
- ⑦ To METER (R)⊖

MAIN AMP CIRCUIT BOARD (BOTTOM VIEW)

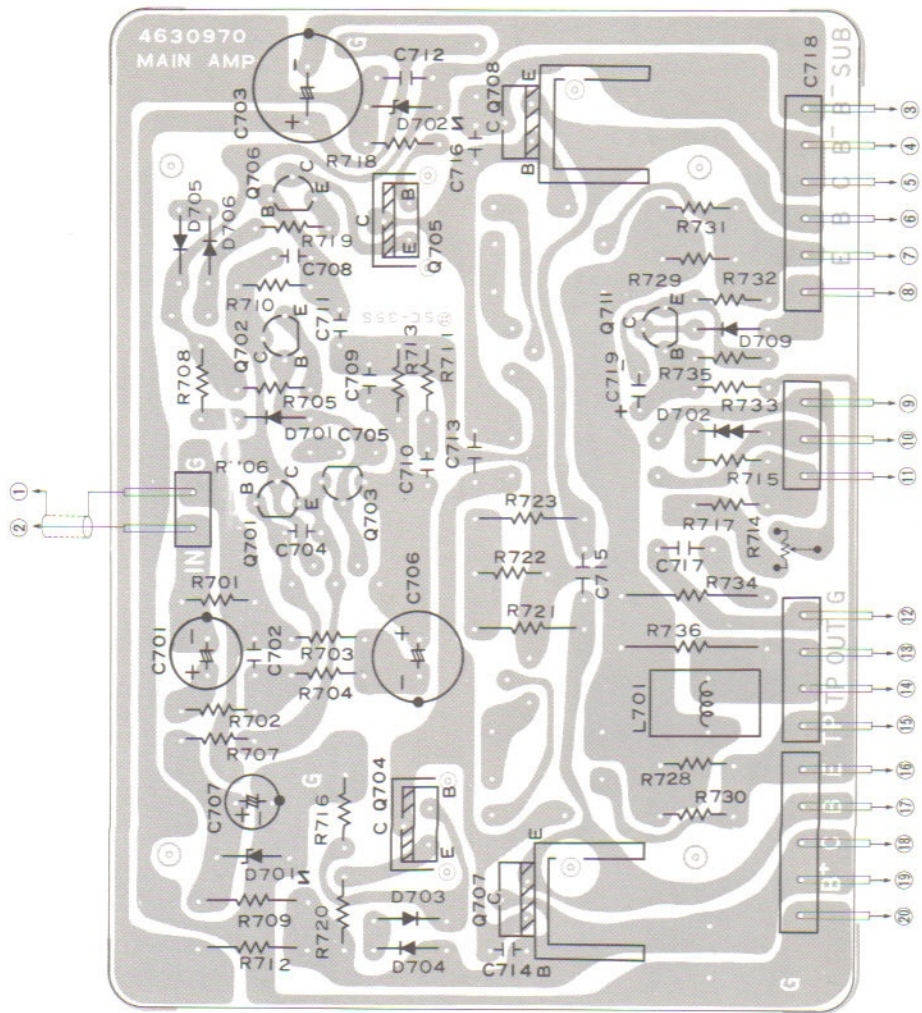

- L-CHANNEL**
- ① To INPUT TERMINAL L (GROUND)
- ② To INPUT TERMINAL L
- ③ To REGULATOR C.B. ⑤
- ④ To C1⊖
- ⑤ To Q3L(2SB600) C
- ⑥ To Q3L(2SB600) B
- ⑦ To Q3L(2SB600) E
- ⑧ To PROTECTOR C.B. ④
- ⑨ To Q1L(2SC1627) E
- ⑩ To Q1L(2SC1627) C
- ⑪ To Q1L(2SC1627) B
- ⑫ To EARTH LUG
- ⑬ To PROTECTOR C.B. ①
- ⑭ To TEST POINT (FOR IDLING CURRENT ADJUSTMENT)
- ⑮
- ⑯ To Q2L(2SD555) E
- ⑰ To Q2L(2SD555) B
- ⑱ To Q2L(2SD555) C
- ⑲ To C3⊕
- ⑳ To EARTH LUG

- R-CHANNEL**
- ① To INPUT TERMINAL R (GROUND)
- ② To INPUT TERMINAL R
- ③ To REGULATOR C.B. ③
- ④ To C2⊖
- ⑤ To Q3R(2SB600) C
- ⑥ To Q3R(2SB600) B
- ⑦ To Q3R(2SB600) E
- ⑧ To PROTECTOR C.B. ⑤
- ⑨ To Q1R(2SC1627) E
- ⑩ To Q1R(2SC1627) C
- ⑪ To Q1R(2SC1627) B
- ⑫ To EARTH LUG
- ⑬ To PROTECTOR C.B. ②
- ⑭ To TEST POINT (FOR IDLING CURRENT ADJUSTMENT)
- ⑮
- ⑯ To Q2L(2SD555) E
- ⑰ To Q2L(2SD555) B
- ⑱ To Q2L(2SD555) C
- ⑲ To C4⊕
- ⑳ To EARTH LUG

PARTS LOCATION

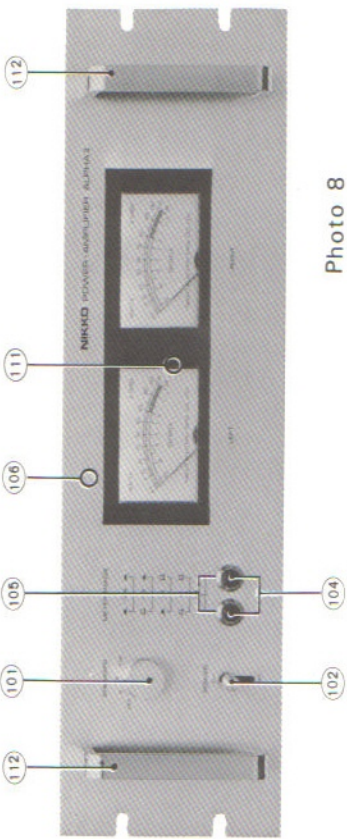

Photo 8

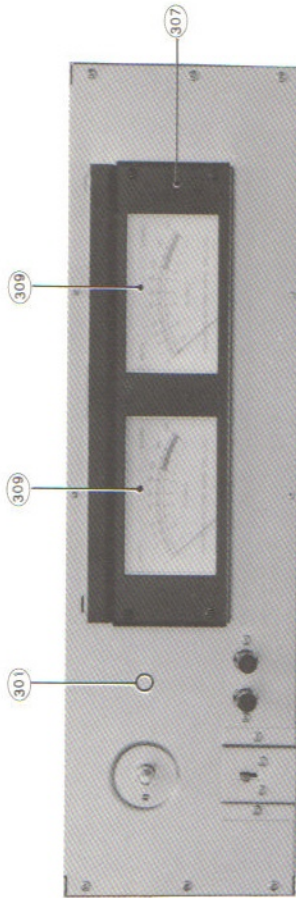

Photo 9

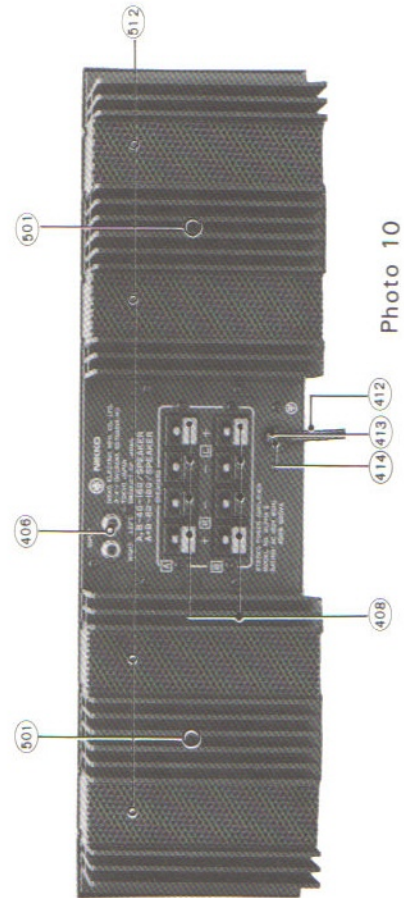

Photo 10

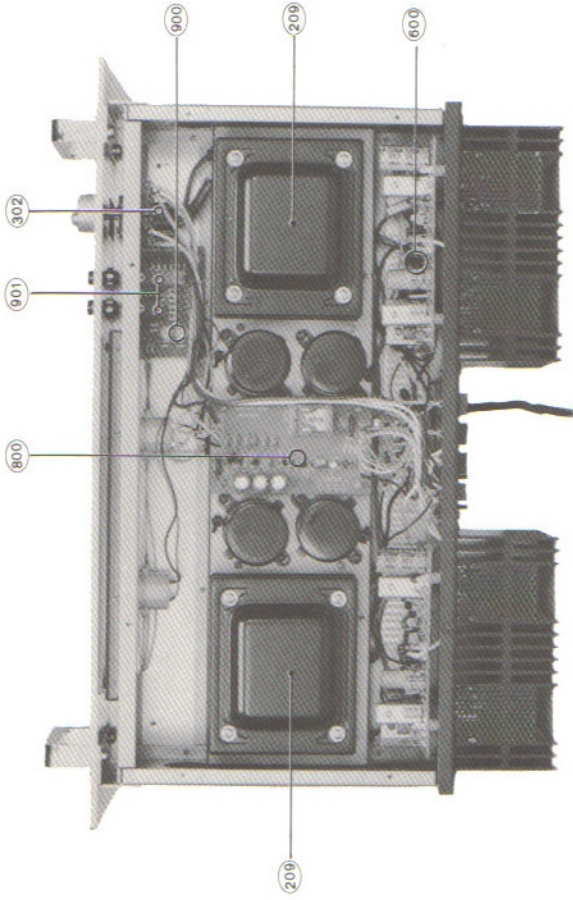

Photo 11

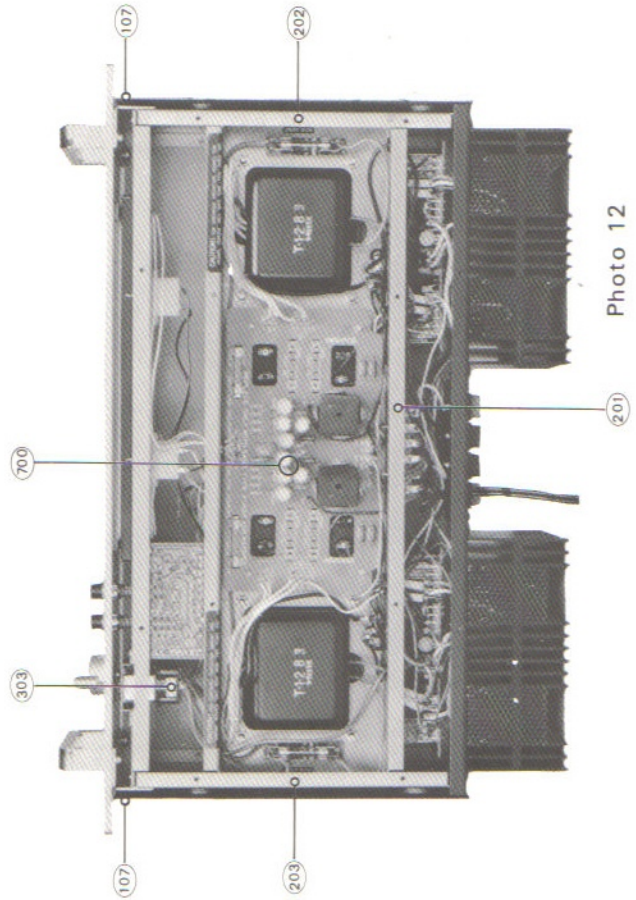

Photo 12

PARTS LIST

NOTES

- "KEY NO." marked with a (★) on parts list relate to numbers of three figures put a (○) around on Photo 1 thru 12.
- + Numbers in file indicate the quantity of parts used in one type.
- ++ TR: Transistor
FET: Field effect transistor
IC: Integrated circuit
VR: Volume control (Variable resistor)
POT: Potentiometer (Semi-fixed variable resistor)
RES: Carbon film fixed resistor
MO-RES: Metal oxide film fixed resistor
CEM-RES: Cemented wire-wound fixed resistor
FP: Flame proof
C-CAP: Ceramic capacitor
E-CAP: Aluminium electrolytic capacitor

- M-CAP: Polyester film capacitor
S-CAP: Polystyrene film capacitor
T-CAP: Tantalum electrolytic capacitor
BP-CAP: Bipolar electrolytic capacitor

E-CAP, T-CAP and BP-CAP values(1x10uF) are in (1)uF, (10)V.

- Assemblies and parts is subject to change without notice.
- Parts ordering procedure:
Include in any order
a. Part number.
b. Part description.
c. Model number.
(any of the above lacking from an order may delay shipment of the order.)

KEY NO.	SYMBOL NO.	TYPE ⁺ W-type-u E-type-u N-type-d D-type-g	DESCRIPTION ⁺⁺	PART NO.
---------	------------	---	---------------------------	----------

PACKING MATERIALS & ACCESSORIES

001	1 1 1 1		CARTON BOX	9825290
002	2 2 2 2		STYROL PAD	9840670
003	1 1 1 1		VINYL CLOTH BAG-POLY SACK	9640660
004	1 1 1 1		VINYL CLOTH BAG-POLY SACK#13	9640320
005a	1 - - -		INSTRUCTION MANUAL E	960187E
005b	- 1 1 -		INSTRUCTION MANUAL K	960199K
005c	- - - 1		INSTRUCTION MANUAL G	960202G
006	1 - - -		WARRANTY CARD (N)	967003A
007	1 1 1 1		POLISHING CLOTH	9690040
008	1 1 1 1		DRYER SILICA GEL	9690010

CABINET ASSEMBLY

(CHAMPAGNE-GOLD TYPE)

★101a	1 1 1 1		KNOB 2GL-26D (speakers)	7851470
★102a	1 1 1 1		KNOB PC-16 (power)	7850590
103	1 1 1 1		DUST COVER	7001760
★104	2 2 2 2		PUSHBUTTON P10B (meter)	7851680
★105	2 2 2 2		PUSHBUTTON GUIDE	7851690
★106a	1 1 1 1		FRONT PANEL-PNL ALPHA II G	7883650
★107	2 2 2 2		PANEL BRACKET	7031250
108	4 4 4 4		SCREW PMS 5 x 14	810514S
109	4 4 4 4		WASHER TW (I) 5φ	893405U
110	6 6 6 6		SCREW PTS 3 x 8	814308S
★111	1 1 1 1		PANEL SMOKE (meter)	7802220
★112a	2 2 2 2		HANDLE A-42-A-6	7890140
★113a	1 1 1 -		STEEL COVER-COV ALPHA II W-E-N	7820730
113b	- - - 1		STEEL COVER-COV ALPHA II D	7820760
114	4 4 4 4		SCREW TFTS 4 x 10 B	887410W
115	4 4 4 4		WASHER W 4φ B	893104W
116	4 4 4 4		SCREW PTS 3 x 6 B	814306W
★117	1 1 1 1		BOTTOM PLATE	7324650
118	6 6 6 6		SCREW PTS 3 x 6	814306S
118	6 6 6 6		SCREW PTS 3 x 6	814306S

KEY NO.	SYMBOL NO.	TYPE ⁺ W-type-u E-type-u N-type-d D-type-g	DESCRIPTION ⁺⁺	PART NO.
---------	------------	---	---------------------------	----------

(BLACK TYPE)

101b	1 1 1 1		KNOB 2BK-26D (speakers)	7851760
102b	1 1 1 1		KNOB PC-16B (power)	7851790
103	1 1 1 1		DUST COVER	7001760
104	2 2 2 2		PUSHBUTTON P10B (meter)	7851680
105	2 2 2 2		PUSHBUTTON GUIDE	7851690
106b	- - - 1		FRONT PANEL-PNL ALPHA II BY	7883720
106c	1 1 1 -		FRONT PANEL-PNL ALPHA II BW	7883750
107	2 2 2 2		PANEL BRACKET	7031250
108	4 4 4 4		SCREW PMS 5 x 14	810514S
109	4 4 4 4		WASHER TW (I) 5φ	893405U
110	6 6 6 6		SCREW PTS 3 x 8	814308S
111	1 1 1 1		PANEL SMOKE (meter)	7802220
112b	2 2 2 2		HANDLE (B) A-42	7890150
113a	1 1 1 -		STEEL COVER-COV ALPHA II W-E-N	7820730
113b	- - - 1		STEEL COVER-COV ALPHA II D	7820760
114	4 4 4 4		SCREW TFTS 4 x 10 B	887410W
115	4 4 4 4		WASHER W 4φ B	893104W
116	4 4 4 4		SCREW PTS 3 x 6 B	814306W
117	1 1 1 1		BOTTOM PLATE	7324650
118	6 6 6 6		SCREW PTS 3 x 6	814306S
118	6 6 6 6		SCREW PTS 3 x 6	814306S

CHASSIS ASSEMBLY

200a	1 - - -		COMPLETE ASSEMBLY-CHASS ASS W	9534390
200b	- 1 - -		COMPLETE ASSEMBLY-CHASS ASS E	9534400
200c	- - 1 -		COMPLETE ASSEMBLY-CHASS ASS N	9534410
200d	- - - 1		COMPLETE ASSEMBLY-CHASS ASS D	9534550
★201	1 1 1 1		CHASSIS	7324660
★202	1 1 1 1		SIDE ANGLE (R)	7226240
★203	1 1 1 1		SIDE ANGLE (L)	7226250
204	6 6 6 6		SCREW PTS 3 x 6 (FRONT PLATE ASSEMBLY)	814306S
205	6 6 6 6		SCREW PTS 3 x 6 (BACK PLATE ASSEMBLY)	814306S
206	6 6 6 6		SCREW PTS 3 x 6 (REG PCB ASS)	814306S
207	5 5 5 5		PCB SUPPORT PIN (PROTECT PCB ASS)	7401320
208	4 4 4 4		PCB SUPPORT PIN	7401320
★209a	2 - - -		POWER TRANSFORMER T-1-283 120V	1102830

PART ORDERING PROCEDURE ----- Include in any order: A. Part number, B. Part description, C. Model number.
 (any of the above lacking from an order may delay shipment of that order.)

KEY NO.	SYMBOL NO.	TYPE ⁺ W-type-u E-type-u N-type-d D-type-g	DESCRIPTION ⁺⁺	PART NO.	KEY NO.	SYMBOL NO.	TYPE ⁺ W-type-u E-type-u N-type-d D-type-g	DESCRIPTION ⁺⁺	PART NO.
209b		- 2 -	POWER TRANSFORMER T-290 220V/240V	1102900	400b		- 1 - -	COMPLETE ASSEMBLY-BACK PLT ASS E	9512890
209c		- - - 2	POWER TRANSFORMER T-297 220V/240V	1102970	400c		- - - 1 -	COMPLETE ASSEMBLY-BACK PLT ASS Nd	9512900
210		8 8 8 8	NUT IN 4φ	892014S	400d		- - - 1	COMPLETE ASSEMBLY-BACK PLT ASS D	9513060
211		8 8 8 8	WASHER TW (I) 4φ	893404U					
212	C1 C4	4 4 4 4	E-CAP 63R10000uF	212650S					
213		8 8 8 8	SCREW BLTS 3 x 6	874306S					
214a		2 - - -	FUSE 5A 250V (UL)	4700540	★401a		1 - - -	BACK PLATE W	7324680
215a		2 - - -	FUSE HOLDER 1P	4581840	401b		- 1 - -	BACK PLATE E	7324890
216a		2 - - -	SCREW PTS 3 x 8	814308S	401c		- - 1 -	BACK PLATE N	
214b		- 2 2 2	MIDGET FUSE (S) 3.15A	4720390	401d		- - - 1	BACK PLATE D	7324880
215b		- 2 2 2	MIDGET FUSE HOLDER 1P	4581430				(MAIN AMP PCB ASS)	
216b		- 2 2 2	SCREW PTS 3 x 6	814306S	402		8 8 8 8	PCB SUPPORT PIN LCBS-8	7401310
217		3 3 3 3	SNAP BUSHING B-500-375	7401090	403		4 4 4 4	SNAP BUSHING	7401090
218		4 4 4 4	SNAP BUSHING B-312-250	7401100				(HEATSINK S. ASS)	
219		2 2 2 2	EARTH LUG 4P WP	4400100	404		8 8 8 8	SCREW PTS 3 x 8 B	814308W
220		2 2 2 2	SCREW PTS 3 x 6	814306S	405		8 8 8 8	WASHER W 3φ	893103S
221		2 2 2 2	WASHER TW(I) 3φ	893403U	★406		1 1 1 1	WP PIN TERMINAL 2P (SE) (input)	4442020
222	R1	1 - - -	RES 2.2M-ohm 5% 1/2W	325225K	407		2 2 2 2	SCREW PMS 3 x 8 B	810308W
223		1 1 1 1	T-LUG 2L4P (W)	442241W	★408		2 2 2 2	4P PUSH TERMINAL (speaker)	4460480
224		2 2 2 2	SCREW PTS 3 x 6	814306S	409		4 4 4 4	SCREW PTS 3 x 10 B	814310W
			FRONT PLATE ASSEMBLY		★412a		1 - - -	POWER SUPPLY CORD KP-2	606006A
300a		1 - - -	COMPLETE ASSEMBLY FRONT PLT ASS W	9521820	412b		- 1 1 -	POWER SUPPLY CORD CEE-2T	600506J
300b		- 2 - -	COMPLETE ASSEMBLY FRONT PLT ASS E	9521830	412c		- - - 1	POWER SUPPLY CORD CEE-3T	601809A
300c		- - 1 -	COMPLETE ASSEMBLY FRONT PLT ASS N	9521840	★413a		1 - - -	CORD STOPPER SR-3P-4	7400620
300d		- - - 1	COMPLETE ASSEMBLY FRONT PLT ASS D	9521920	413b		- 1 1 -	CORD STOPPER SR-4N-4	7400690
					413c		- - - 1	CORD STOPPER SR-6W-1	7400740
					★414a		1 - - -	CORD BRACKET (UL)	7029300
					414b		- 1 1 1	CORD BRACKET (EH)	7029800
					415		2 2 2 2	SCREW PTS 3 x 6 B	814306W
								HEATSINK ASSEMBLY	
					500a		1 1 1 -	COMPLETE ASSEMBLY H-SINK S. ASS	
★301		1 1 1 1	FRONT PLATE	7324670	500b		- - - 1	COMPLETE ASSEMBLY H-SINK S. Ass	
★302a	S2	1 1 1 -	ROTARY SWITCH 1-2-4 (speakers)	4051130					
302b	S2	- - - 1	ROTARY SWITCH 1-4-4 (speakers)	4051170					
★303a	S1	1 - - -	LEVER ACTION SWITCH LV SW SY02 U74SM (power)	4025090	★501		2 2 2 2	HEATSINK	7480310
303b	S1	- 1 1 1	LEVER ACTION SWITCH LV SW SY02 80DB (power)	4025150	502	Q2L	1 1 1 1	TR 2SD555 (Q,R)	513768S
304		2 2 2 2	SCREW PMS 3 x 6	810306S	503	Q2R	1 1 1 1	TR 2SD555 (Q,R)	513768S
305		1 1 1 1	POWER SWITCH BRACKET	7031260	504	Q3L	1 1 1 1	TR 2SB600 (Q,R)	513067S
306		2 2 2 2	SCREW PTS 3 x 6	814306S	505	Q3R	1 1 1 1	TR 2SB600 (Q,R)	513067S
★307		1 1 1 1	BACK GROUND PANEL	7226260	506		4 4 4 4	POWER TRANSISTOR SOCKET	4510080
308		4 4 4 4	SCREW PTS 3 x 6	814306S	507		8 8 8 8	SCREW PMS 3 x 16	810316S
★309a		2 2 2 -	METER 677 (8OHM)	4582040	508		8 8 8 8	WASHER TW(I) 3φ	893403U
309b		- - - 2	METER 677 (4OHM)	4582130	509		2 2 2 2	BIAS CONTROL PCB	4630940
★310		1 1 1 1	METER HOLDER	7226270	510	Q1L	1 1 1 1	TR 2SC1627 (O,Y)	511017S
311		4 4 4 4	SCREW PTS 3 x 6	814306S	511	Q1R	1 1 1 1	TR 2SC1627 (O,Y)	511017S
312		1 1 1 1	LAMP PCB	4630930	★512		4 4 4 4	HEATSINK COVER	7226280
313		4 4 4 4	LAMP PL-8 8V 0.25A BLUE	5808130	513		8 8 8 8	SCREW PTS 3 x 6 B	814306W
★314		3 3 3 3	PUSH RIVET FNRP 3 x 4.5 (MT SW PCB S, ASS)	7401240	514		8 8 8 8	SCREW PTS 3 x 6 B	814306W
315		2 2 2 2	SCREW PMS 3 x 6	810306S	515		8 8 8 8	SCREW PTS 3 x 8 B (heatsink)	814308W
316	C4	1 - - -	C-CAP 0.0047uF	239472C	516		8 8 8 8	WASHER W 3φ	893103S
317		1 - - -	C-CAP COVER (M)	7400980	517		- - - 2	THERMOSTAT US-601-80	4900720
					518		- - - 4	SCREW PTS 3 x 6 B	814306W
			BACK PLATE ASSEMBLY					MAIN AMP CIRCUIT BOARD (only left channel)	
400a		1 - - -	COMPLETE ASSEMBLY-BACK PLT ASS W	9512880	★600a		1 1 1 -	COMPLETE CIRCUIT BOARD-MAIN AMP PCB ASS WEN	9430640

PART ORDERING PROCEDURE ----- Include in any order: A. Part number, B. Part description, C. Model number.
 (any of the above lacking from an order may delay shipment of that order.)

KEY NO.	SYMBOL NO.	TYPE ⁺ W-type-u E-type-u N-type-d D-type-g	DESCRIPTION ⁺⁺	PART NO.	KEY NO.	SYMBOL NO.	TYPE ⁺ W-type-u E-type-u N-type-d D-type-g	DESCRIPTION ⁺⁺	PART NO.
600b		---	COMPLETE CIRCUIT BOARD—MAIN AMP PCB ASS D	9430650		R736L	1 1 1 1	FP-MO-RES 10ohm 5% 2W	362100L
	C701L	1 1 1 1	E-CAP 16R100uF	211230Q		Q701L	1 1 1 1	TR 2SA941 (BL)	510048S
	C702L	1 1 1 1	C-CAP 100pF 10% 50V SL	232101K		Q702L	1 1 1 1	TR 2SC2088 (BL)	511023S
	C703L	1 1 1 1	E-CAP 80R220uF	211732Q		Q703L	1 1 1 1	TR 2SA941 (BL)	510048S
	C704L	1 1 1 1	C-CAP 47pF 10% 50V SL	232470K		Q704L	1 1 1 1	TR 2SB536 (L,M)	510039S
	C705L		Out of use				1 1 1 1	HEATSINK	7081820
	C706L	1 1 1 1	E-CAP 16uF470uF	211235Q			1 1 1 1	SCREW PMS 3 x 5	810305S
	C707L	1 1 1 1	E-CAP 25R10uF	211320V		Q705L	1 1 1 1	TR 2SD381 (L,M)	510038S
	C708L	1 1 1 1	C-CAP 47pF 10% 50V SL	232470K			1 1 1 1	HEATSINK	7081820
	C709L	1 1 1 1	C-CAP 10pF 10% 500V SL	234100K			1 1 1 1	SCREW PMS 3 x 5	810305S
	C710L	1 1 1 1	C-CAP 5pF ±0.5pF 500V SL	234509D		Q706L	1 1 1 1	TR 2SC1627 (O,Y)	511017S
	C711L	1 1 1 1	C-CAP 68pF 10% 500V SL	234680K		Q707L	1 1 1 1	TR 2SD381 (L,M)	510038S
	C712L	1 1 1 1	M-CAP 0.01uF 10% 50V	222103K			1 1 1 1	HEATSINK 1627NT	7780270
	C713L	1 1 1 1	M-CAP 0.047uF 10% 50V	222473K			2 2 2 2	SCREW PMS 3 x 5	810305S
	C714L	1 1 1 1	C-CAP 100pF 10% 500V SL	234101K		Q708L	1 1 1 1	TR 2SB536 (L,M)	510039S
	C715L	1 1 1 1	M-CAP 0.047uF 10% 50V	222473K			1 1 1 1	HEATSINK 1627NT	7480270
	C716L	1 1 1 1	C-CAP 100pF 10% 500V SL	234101K			2 2 2 2	SCREW PMS 3 x 5	810305S
	C717L	1 1 1 1	M-CAP 0.047uF 1-1% 200V	272473K		Q709L	1 1 1 -	TR 2SC945 (P,Q)	515077S
	C718L	1 1 1 1	M-CAP 0.1uF 20% 50V	222104M		Q710L	1 1 1 -	TR 2SA733 (R,Q)	514074S
	C719L	1 1 1 1	E-CAP 50R 0.47uF	211505Q		Q711L	1 1 1 1	TR 2SC2088 (BL)	511023S
	D701L	1 1 1 1	DIODE 1S2076 (LIGHT BLUE)	501019S		Z701L	1 1 1 1	ZENER DIODE XZ-225	502036S
	D702L	1 1 1 1	DIODE VD1212	505016S		Z702L	1 1 1 1	ZENER DIODE WZ-069	502035S
	D703L	1 1 1 1	DIODE 1S2076 (LIGHT BLUE)	501019S					
	D704L	1 1 1 1	DIODE 1S2076 (LIGHT BLUE)	501019S					
	D705L	1 1 1 1	DIODE 1S2076 (LIGHT BLUE)	501019S					
	D706L	1 1 1 1	DIODE 1S2076 (LIGHT BLUE)	501019S		700a	1 - - -	COMPLETE CIRCUIT BOARD— REG PCB ASS W	9450660
	D707L	1 1 1 1	DIODE 1S2076 (LIGHT BLUE)	501019S		700b	- 1 1 -	COMPLETE CIRCUIT BOARD— REG PCB ASS EN	9450670
	D708L	1 1 1 1	DIODE 1S2076 (LIGHT BLUE)	501019S		700c	- - - 1	COMPLETE CIRCUIT BOARD— REG PCB ASS D	9450700
	D709L	1 1 1 1	DIODE 1S2076A (NAVY BLUE)	501020S					
	L701L	1 1 1 1	CHOKO COIL	1210830					
	R701L	1 1 1 1	RES 100Kohm 5% 1/4W	328104J					
	R702L	1 1 1 1	RES 22Kohm 5% 1/4W	328223J					
	R703L	1 1 1 1	RES 330Kohm 5% 1/4W	328331J		C801			
	R704L	1 1 1 1	RES 10Kohm 5% 1/4W	328103J		~C808	8 8 8 8	E-CAP 10R220uF	211132Q
	R705L	1 1 1 1	RES 470ohm 5% 1/4W	328471J		C809	1 1 1 1	C-CAP 0.01uF 100, -0% 500V	238103P
	R706L		Out of use			C810	1 1 1 1	C-CAP 0.01uF 100, -0% 500V	238103P
	R707L	1 1 1 1	RES 12Kohm 5% 1/4W	328123J		C811			
	R708L	1 1 1 1	RES 470ohm 5% 1/4W	328471J		~C818	8 8 8 8	C-CAP 0.01uF 100, -0% 500V	238103P
	R709L	1 1 1 1	FP-MO-RES 5.6Kohm 5% 1/2W	360562L					
	R710L	1 1 1 1	RES 1Kohm 5% 1/4W	328102J		D801			
	R711L	1 1 1 1	RES 56Kohm 5% 1/4W	328563J		~D808	8 8 8 8	DIODE 1S2076	501019S
	R712L	1 1 1 1	FP-MO-RES 33Kohm 5% 1/2W	360333L		D809	1 1 1 1	DIODE S5VB20	560042S
	R713L	1 1 1 1	RES 10Kohm 5% 1/4W	328103J		D810	1 1 1 1	DIODE S5VB20	560042S
	R714L	1 1 1 1	POT—H-VR SR29R207 B 1Kohm	4300620					
	R715L	1 1 1 1	RES 560ohm 5% 1/4W	328561J		F801	1 - - -	FUSE 1A 125V (-B SUB)	4700020
	R716L	1 1 1 1	RES 47Kohm 5% 1/4W	328473J		F802	1 - - -	FUSE 1A 125V (-B SUB)	4700020
	R717L	1 1 1 1	RES 330ohm 5% 1/4W	328331J			4 - - -	FUSE HOLDER	7050420
	R718L	1 1 1 1	RES 100ohm 5% 1/4W	328101J		F801	- 1 1 1	MIDGET FUSE (S) 1AT (-B SUB)	4720330
	R719L	1 1 1 1	RES 100ohm 5% 1/4W	328101J		F802	- 1 1 1	MIDGET FUSE (S) 1AT (-B SUB)	4720330
	R720L	1 1 1 1	RES 56ohm 5% 1/4W	328560J			- 4 4 4	MIDGET FUSE HOLDER	7050430
	R721L	1 1 1 1	FP-MO-RES 68ohm 5% 1/4W	360680J		F803			
	R722L	1 1 1 1	RES 5.6Kohm 5% 1/4W	328562J		F806	- 4 4 -	MIDGET FUSE (S) 5AT (+B/-B)	4720410
	R723L	1 1 1 1	FP-MO-RES 68ohm 5% 1/4W	360680L			- 8 8 -	MIDGET FUSE HOLDER	7050430
	R724L	1 1 1 -	FP-MO-RES 68ohm 5% 1/2W	360680L					
	R725L	1 1 1 -	FP-MO-RES 68ohm 5% 1/2W	360680L		R801	1 1 1 1	FP-MO-RES 68ohm 5% 1/2W	360680L
	R726L	1 1 1 -	FP-MO-RES 150ohm 5% 1/2W	360151L		R802	1 1 1 1	FP-MO-RES 68ohm 5% 1/2W	360680L
	R727L	1 1 1 -	FP-MO-RES 150ohm 5% 1/2W	360151L		R803			
	R728L	1 1 1 1	FP-CEM-RES 0.47ohm 10% 1/2W	384479W		R806	4 4 4 4	FP-MO-RES 10Kohm 1/2W	360103L
	R729L	1 1 1 1	FP-CEM-RES 0.47ohm 10% 1/2W	384479W					
	R730L	1 1 1 1	FP-CEM-RES 0.47ohm 10% 1/2W	384479W					
	R731L	1 1 1 1	FP-CEM-RES 0.47ohm 10% 1/2W	384479W					
	R732L	1 1 1 1	RES 5.6Kohm 5% 1/4W	328562J					
	R733L	1 1 1 1	RES 82Kohm 5% 1/4W	328823J					
	R734L	1 1 1 1	FP-MO-RES 10ohm 5% 2W	362100L					
	R735L	1 1 1 1	RES 27Kohm 5% 1/4W	328273L					

PART ORDERING PROCEDURE ----- Include in any order: A. Part number, B. Part description, C. Model number.
 (any of the above lacking from an order may delay shipment of that order.)

KEY NO.	SYMBOL NO.	TYPE ⁺ W-type-u E-type-u N-type-d D-type-g	DESCRIPTION ⁺⁺	PART NO.	KEY NO.	SYMBOL NO.	TYPE ⁺ W-type-u E-type-u N-type-d D-type-g	DESCRIPTION ⁺⁺	PART NO.
			PROTECTOR CIRCUIT BOARD		900b		---	1 COMPLETE CIRCUIT BOARD-- MT SW PCB S.ASS D	9492490
800a		1 1 1 -	COMPLETE CIRCUIT BOARD PROTECT PCB ASS WEN	9450680		D901	1 1 1 1	DIODE 1N34A	500010G
800b		---	1 COMPLETE CIRCUIT BOARD PROTECT PCB ASS D	9450690		D902	1 1 1 1	DIODE 1N34A	500010G
						D903	1 1 1 1	DIODE 1S2076	501019S
						D904	1 1 1 1	DIODE 1S2076	501019S
						D905	1 1 1 1	DIODE 1S2076	501019S
						D906	1 1 1 1	DIODE 1S2076	501019S
						R919	1 1 1 1	POT 1Kohm-H-VR RVA-7B	4300750
						R920	1 1 1 1	POT 1Kohm-H-VR RVA-7B	4300750
C840		1 1 1 1	E-CAP 50R0.47uF	211505Q		R901	1 1 1 -	RES 820ohm 5% 1/4W	328821J
C841		1 1 1 1	E-CAP 16R220uF	211232Q		R901	---	1 RES 390ohm 5% 1/4W	328391J
C842		1 1 1 1	E-CAP 16R220uF	211232Q		R902	1 1 1 -	RES 820ohm 5% 1/4W	328821J
C843		1 1 1 1	E-CAP 16R220uF	211232Q		R902	---	1 RES 390ohm 5% 1/4W	328391J
C844		1 1 1 1	E-CAP 35R3.3uF	211413Q		R903	1 1 1 1	RES 22Kohm 5% 1/4W	328223J
						R904	1 1 1 1	RES 22Kohm 5% 1/4W	328223J
D840		1 1 1 1	DIODE 1S2076A	501020S		R905	1 1 1 -	RES 5.6Kohm 5% 1/4W	328562J
D841		1 1 1 1	DIODE 1S2076A	501020S		R905	---	1 RES 3.9Kohm 5% 1/4W	328392J
R840		1 1 1 1	RES 100Kohm 5% 1/4W	328104J		R906	1 1 1 -	RES 5.6Kohm 5% 1/4W	328562J
R841		1 1 1 1	RES 27Kohm 5% 1/4W	328273J		R906	---	1 RES 3.9Kohm 5% 1/4W	328392J
R842		1 1 1 1	RES 27Kohm 5% 1/4W	328273J		R907	1 1 1 -	RES 82Kohm 5% 1/4W	328823J
R843		1 1 1 1	RES 47Kohm 5% 1/4W	328473J		R907	---	1 RES 68Kohm 5% 1/4W	328683J
R844		1 1 1 1	RES 68Kohm	328683J		R908	1 1 1 -	RES 82Kohm 5% 1/4W	328823J
R845		---	1 RES 18Kohm 5% 1/4W	328183J		R908	---	1 RES 68Kohm 5% 1/4W	328683J
R846		1 1 1 -	RES 18Kohm 5% 1/4W	328183J		R909	1 1 1 -	RES 12Kohm 5% 1/4W	328123J
R847		1 1 1 1	RES 180Kohm 5% 1/4W	328184J		R909	---	1 RES 8.2Kohm 5% 1/4W	328822J
R848		1 1 1 1	RES 4.7Kohm 5% 1/4W	328472J		R910	1 1 1 -	RES 12Kohm 5% 1/4W	328123J
R849		1 1 1 1	RES 18Kohm 5% 1/4W	328183J		R910	---	1 RES 8.2Kohm 5% 1/4W	328822J
R850		1 1 1 1	RES 100Kohm 5% 1/4W	328104J		R911	1 1 1 -	RES 180Kohm 5% 1/4W	328184J
R851		1 1 1 1	RES 15Kohm 5% 1/4W	328153J		R911	---	1 RES 270Kohm 5% 1/4W	328274J
R852		1 1 1 1	MO-RES 220ohm 5% 1/2W	360221L		R912	1 1 1 -	RES 180Kohm 5% 1/4W	328184J
R853		1 1 1 1	MO-RES 470ohm 5% 1W	361471L		R912	---	1 RES 270Kohm 5% 1/4W	328274J
Q801		1 1 1 1	TR 2SA733 (Q,R)	514074S		R913	1 1 1 -	RES 27Kohm 5% 1/4W	328273J
Q802		1 1 1 1	TR 2SA733 (Q,R)	514074S		R913	---	1 RES 18Kohm 5% 1/4W	328183J
Q803		1 1 1 1	TR 2SC945 L (P,Q)	515077S		R914	1 1 1 -	RES 27Kohm 5% 1/4W	328273J
Q804		1 1 1 1	TR 2SC945 L (P,Q)	515077S		R914	---	1 RES 18Kohm 5% 1/4W	328183J
Q805		1 1 1 1	TR 2SC1627 (O,Y)	511017S		R915	1 1 1 -	RES 150Kohm 5% 1/4W	328154J
801		1 1 1 1	RELAY MAT4B-211R	1700210		R915	---	1 RES 220Kohm 5% 1/4W	328224J
						R916	1 1 1 -	RES 150Kohm 5% 1/4W	328154J
						R916	---	1 RES 220Kohm 5% 1/4W	328224J
						R917	1 1 1 1	RES 560ohm 5% 1/4W	328561J
						R918	1 1 1 1	RES 560ohm 5% 1/4W	328561J
			METER SWITCH CIRCUIT BOARD		901	S901, S902	1 1 1 1	TWIN PUSH BUTTON SWITCH SUE-24 (meter)	4040910
★900a		1 1 1 -	COMPLETE CIRCUIT BOARD-- MT SW PCB S.ASS W-E-N	9492380					

CHASSIS ALIGNMENT

TEST EQUIPMENT

Generator — Audio Frequency
DC Voltmeter — High Sensitivity
Vacuum Tube Voltmeter
(Oscilloscope)

Connect Generator to INPUT of the instrument to be tested. Connect two (2) 8 ohm (D-type: 4 ohm) dummy loads to L-channel and R-channel speaker terminals.

Apply AC power to the instrument.

Allow minimum of 10 minute warm-up period for the instrument and test equipment.

Maintain line voltage at rated voltage.

MIDPOINT VOLTAGE ADJUSTMENT

Left Channel: Using DC Voltmeter, make certain that the voltage between TP 12 and TP 13 on Main Amp Circuit Board is $0\text{mV} \pm 20\text{mV}$.

Right Channel: The same procedure as left channel.

IDLING CURRENT ADJUSTMENT

Left Channel: Using DC Voltmeter, adjust potentiometer R714 so that the voltage between TP 14 and TP 15 on Main Amp Circuit Board is $19\text{mV} \pm 3\text{mV}$.

Right Channel: The same procedure as left channel.

METER SENSITIVITY ADJUSTMENT

Left Channel:

1. Connect VTVM to speaker terminals. Set Meter Range Switches (S901, S902) to 0dB position. Set Generator frequency to 1KHz.
2. Set Generator to produce 120 watts (D-type: 130 watts) power output, Adjust potentiometer R919 on Meter Switch Circuit Board so that Meters are $0\text{dB} \pm 0.5\text{dB}$.

Right Channel: The same procedure as left channel. Adjust potentiometer R920 instead of potentiometer R919.

NIKKO ELECTRIC CORP. OF AMERICA

16270 RAYMER STREET VAN NUYS CALIF. 91406 U.S.A
218 SHERWOOD AVENUE FARMINGDAL NEW YORK 11735 U.S.A

NIKKO ELECTRIC MFG. CO., LTD

HEAD OFFICE: 4-1, 3CHOME, OKUSAWA
SETAGAYA-KU, TOKYO, JAPAN

SALES OFFICE: MITSUBISHI BANK BLDG., 1-3-2
DOGENZAKA, SHIBUYA-KU, TOKYO JAPAN