

SERVICE MANUAL

FAM-450

AM / FM MULTIPLEX STEREO TUNER

NIKKO

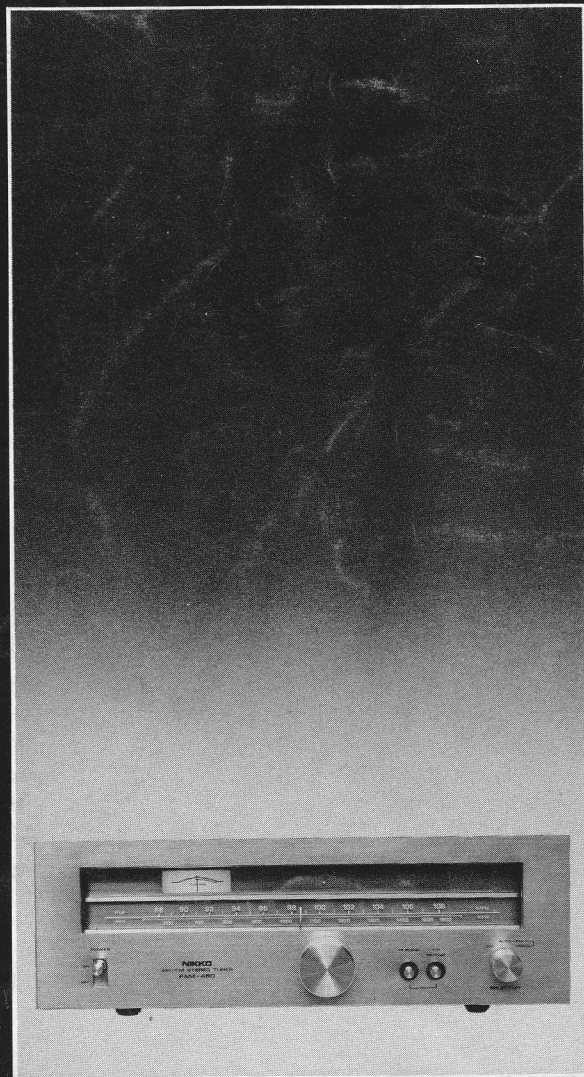

CONTENTS

1. SPECIFICATION	1.
2. EXTERNAL VIEW	2.
3. INTERNAL VIEW	3.
4. PARTIAL DISASSEMBLY	3~5.
5. DIAL MECHANISM	5.
6. MEASUREMENT AND ADJUSTMENT	6~8.
7. PRINTED CIRCUIT BOARD	
TUNER PCB ASSY	9.
8. BLOCK DIAGRAM	10.
9. OVERALL DIAGRAM	11.
10. PARTIAL CHANGES MADE	
ACCORDING DESTINATION	12.
11. PARTS LIST	13~15.
12. SEMICONDUCTOR SPECIFICATION	
TRANSISTOR COMPLEMENT	16.
FIELD EFFECT TRANSISTOR COMPLEMENT	16.
RECTIFIER-DIODE, ZENER-DIODE COMPLEMENT	16.
INTEGRATED CIRCUIT COMPLEMENT	17~19.

SPECIFICATION

1. FM TUNER SECTION

		NOMINAL	LIMIT
Sensitivity	(IHF)	2 μ V	3 μ V
Quieting Slope	(S/N 50dB)	4.5 μ V	10 μ V
Selectivity	(IHF)	55dB	35dB
Image Rejection	(98MHz)	45dB	40dB
IF Rejection	(98MHz)	70dB	60dB
Signal to Noise Ratio	65dB	60dB
Capture Ratio	(IHF)	1.6dB	3dB
Muting Sensitivity	12dB	\pm 8dB
Distortion	(MONO)	0.2%	0.5%
Distortion	(STEREO)	0.5%	1%
Stereo Separation	(1KHz)	42dB	35dB
Output Voltage	690mV	\pm 3dB
De-Emphasis	(50 μ Sec) 10KHz	-10.37dB	\pm 2dB

2. AM TUNER SECTION

Sensitivity	(IHF)	300 μ V/m	1000 μ V/m
Selectivity	(IHF) \pm 10KHz	35dB	30dB
Image Rejection	(1000KHz)	45dB	40dB
IF Rejection	(1000KHz)	35dB	30dB
Distortion	1%	2%
Signal to Noise Ratio	45dB	40dB
Output Voltage	135mV	\pm 2dB

EXTERNAL VIEW

FRONT PANEL

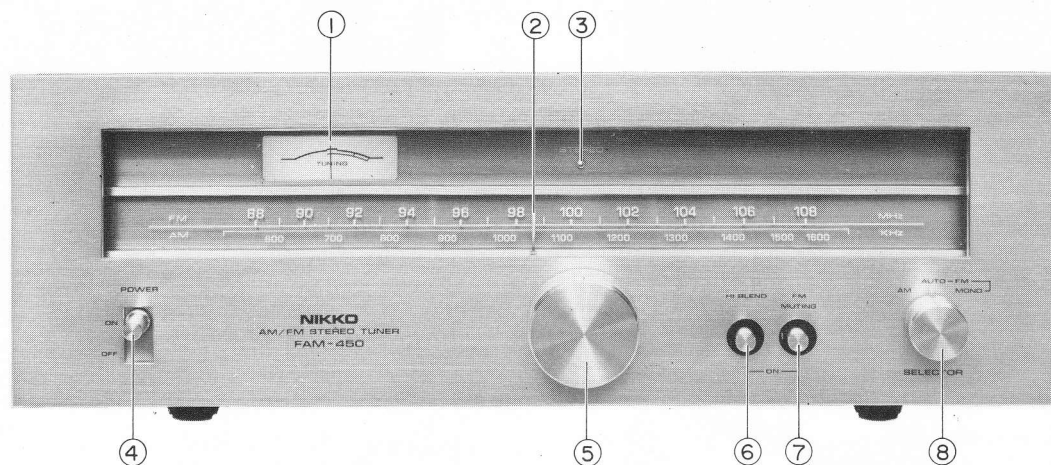

- (1) Signal/Tuning meter
- (2) Dial pointer
- (3) Stereo indicator
- (4) Power switch

- (5) Tuning knob
- (6) Hi-blend switch
- (7) FM muting switch
- (8) Selector switch

REAR PANEL

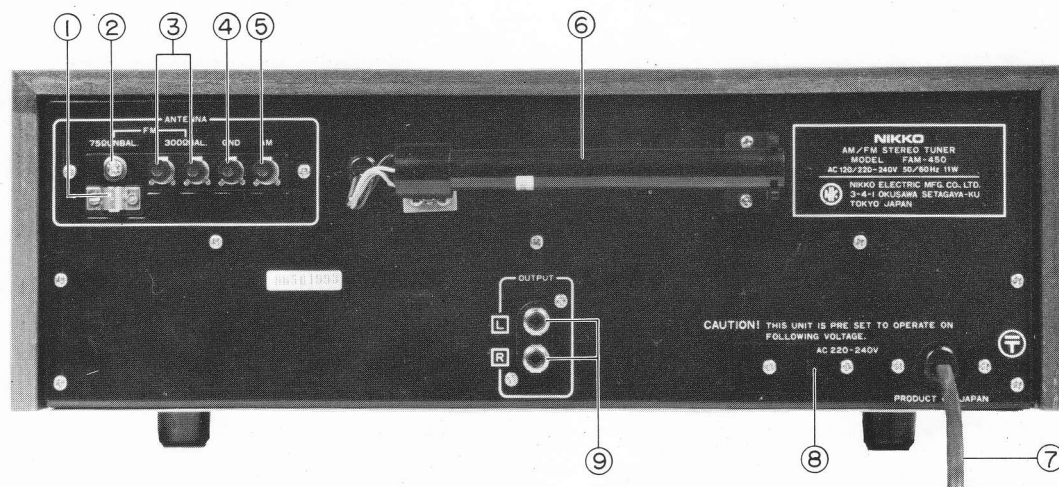

- (1) Coaxial cable holder (GND)
- (2) 75 ohm FM antenna terminal
- (3) 300 ohm FM antenna terminal
- (4) Ground terminal
- (5) AM antenna terminal

- (6) AM bar antenna
- (7) AC supply cord
- (8) AC 220/240 selector switch
- (9) Output terminal

INTERNAL VIEW

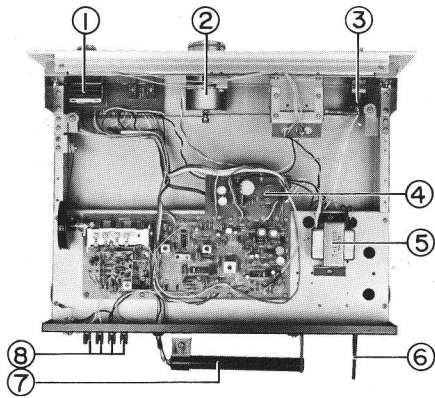

TOP VIEW

- (1) Selector switch
- (2) Fly wheel
- (3) Power switch
- (4) Tuner PCB ass'y board
- (5) Power transformer
- (6) AC cord
- (7) AM bar antenna
- (8) Antenna terminals

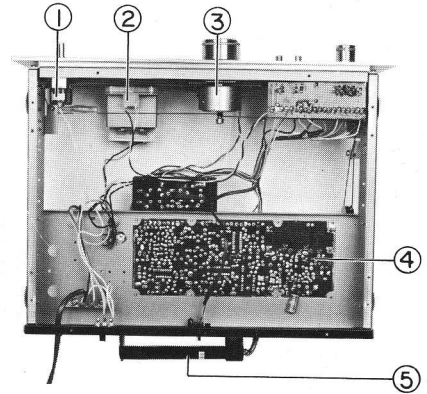

BOTTOM VIEW

- (1) Power switch
- (2) Signal/Tuning meter
- (3) Fly wheel
- (4) Tuner PCB ass'y board
- (5) AM bar antenna

PARTIAL DISASSEMBLY

CABINET REMOVAL

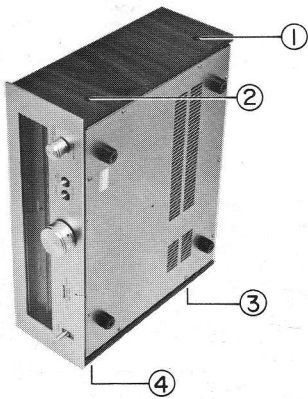

PHOTO-1

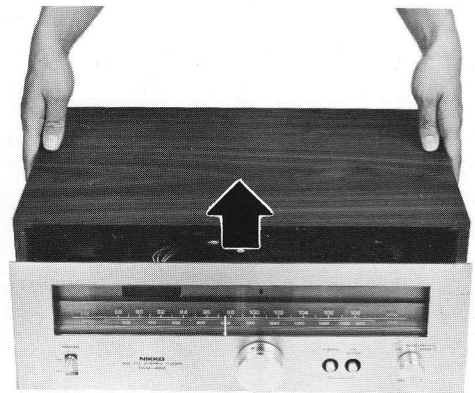

PHOTO-2

Stand the cabinet up and remove screws (1-4) as shown in Photo-1.

Return the cabinet to its original position and pull forward and then lift up to remove it (Photo-2).

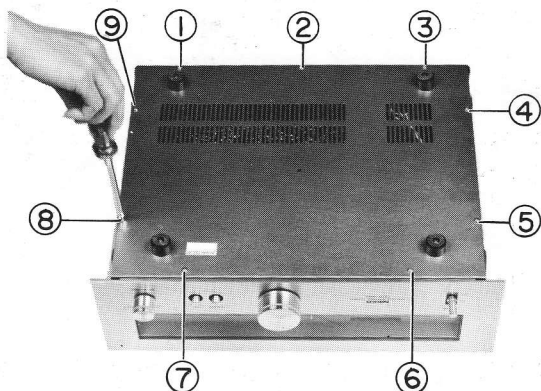

PHOTO-3

BOTTOM PLATE REMOVAL

Turn the cabinet and remove screws (1-9) as shown in Photo-3.

FRONT PANEL REMOVAL

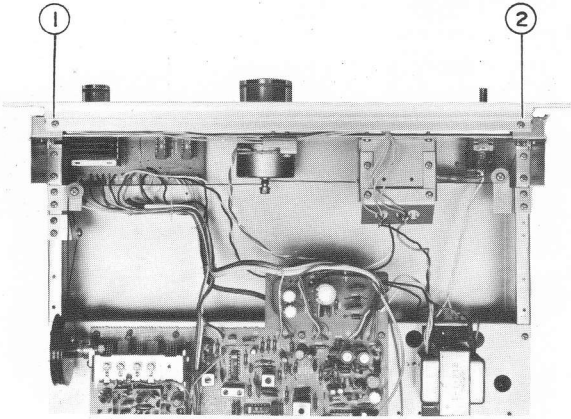

PHOTO-4

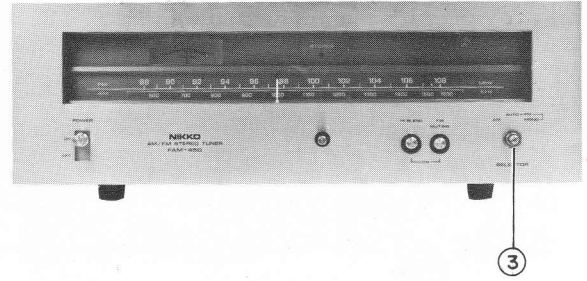

PHOTO-5

Remove screws (1-2) and nut (3) as shown in Photo 4-5.

TUNER PCB ASSY BOARD REMOVAL

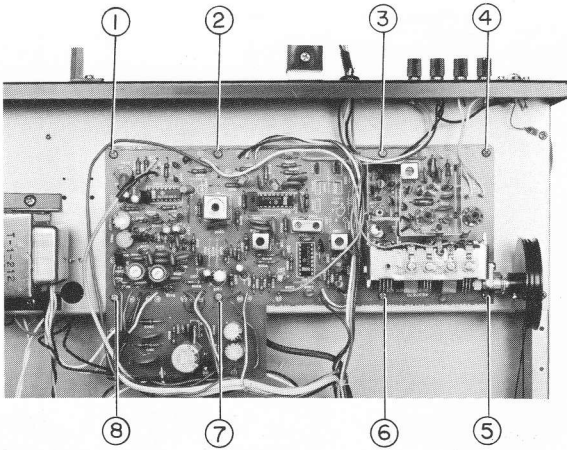

PHOTO-6

Remove screws (1-8) as shown in Photo 6 then lift the circuit board up to remove it.

POWER TRANSFORMER REMOVAL

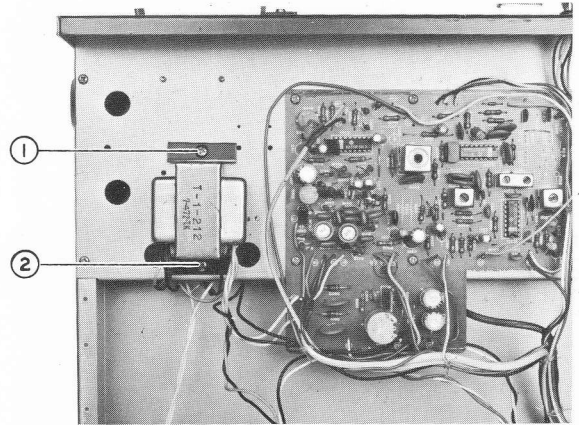

PHOTO-7

Remove screws (1-2) as shown in Photo 7 then lift the transformer up to remove it.

SWITCH PCB ASSY REMOVAL

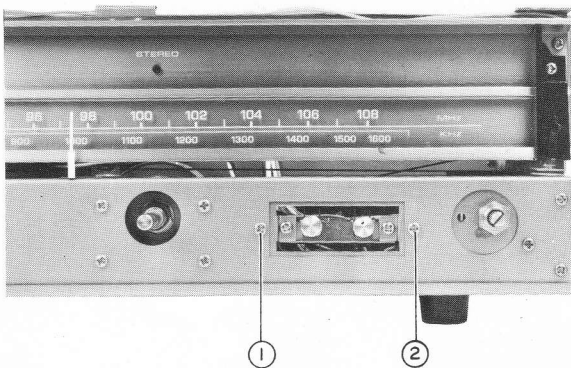

PHOTO-8

Remove screws (1-2) as shown in Photo 8 and pull forward to remove it.

FLY WHEEL REMOVAL

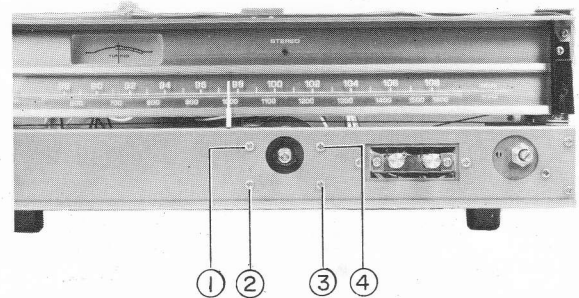

PHOTO-9

Remove screws (1-4) as shown in Photo 9 and pull forward to remove it.

POWER SWITCH REMOVAL

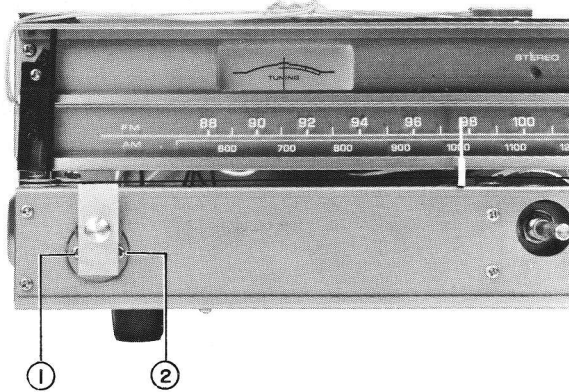

PHOTO-10

Remove screws (1-2) as shown in Photo 10 and pull forward to remove it.

METER REMOVAL

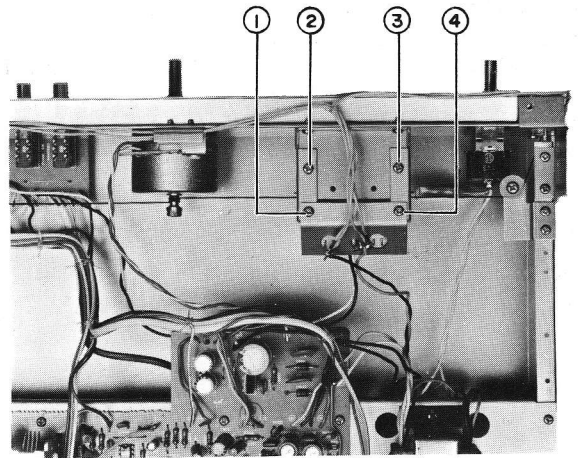
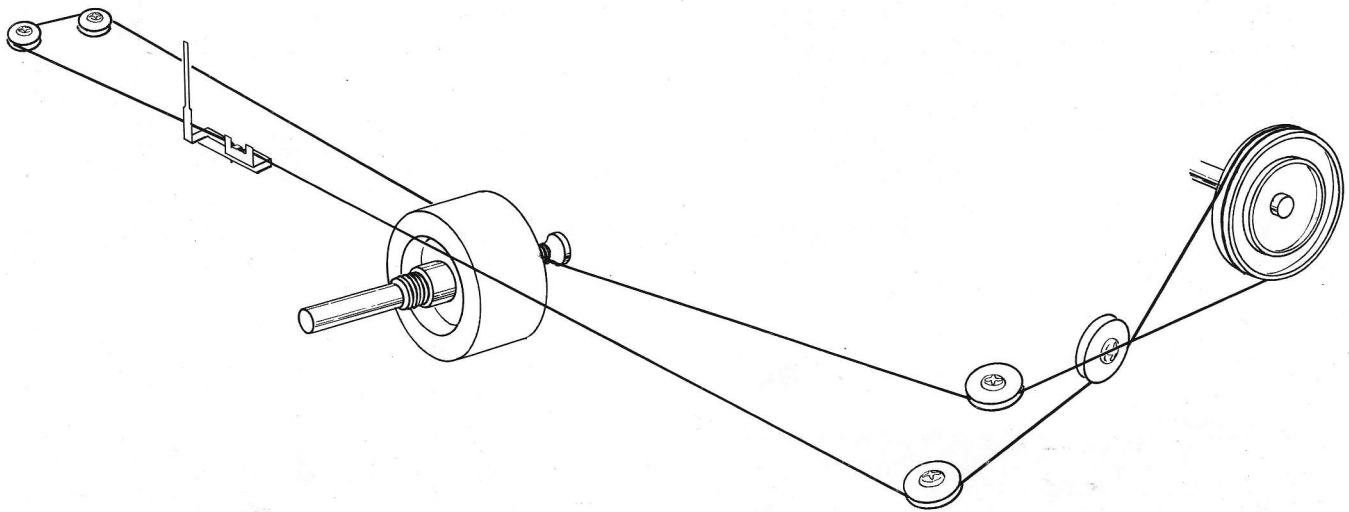

PHOTO-11

Remove screws (1-4) as shown Photo 11 and pull forward to remove it.

DIAL MECHANISM



MEASUREMENT AND ADJUSTMENT

Set the tuning dial pointer to zero(0) position on the dial panel.

If the dial pointer fails to coincide with the zero(0) position at the left end of the knob rotation, have it reset to zero(0) position by sliding on the dial string and then proceed as follows.

FM SECTION

1. FREQUENCY COVERAGE AND TRACKING ADJUSTMENT

For connecting, refer to Fig. 1.

For adjusting point, refer to Fig. 2.

Step	Generator and Dial Freq.	Adjust	Indication and Remarks
1	88 MHz	L104	Oscillator coil core Adjust for max. reading
2	108 MHz	C111	Oscillator Trimmer Adjust for max. reading
3	88 MHz	L101	ANT coil core, RF coil core
4	108 MHz	FM1	Adjust for max. reading
5	88 MHz	L102	ANT coil core, RF coil core
6	108 MHz	FM2	Adjust for max. reading
7	Repeat step 1, 2, 3, 4, 5, 6 Align after complete tuning		

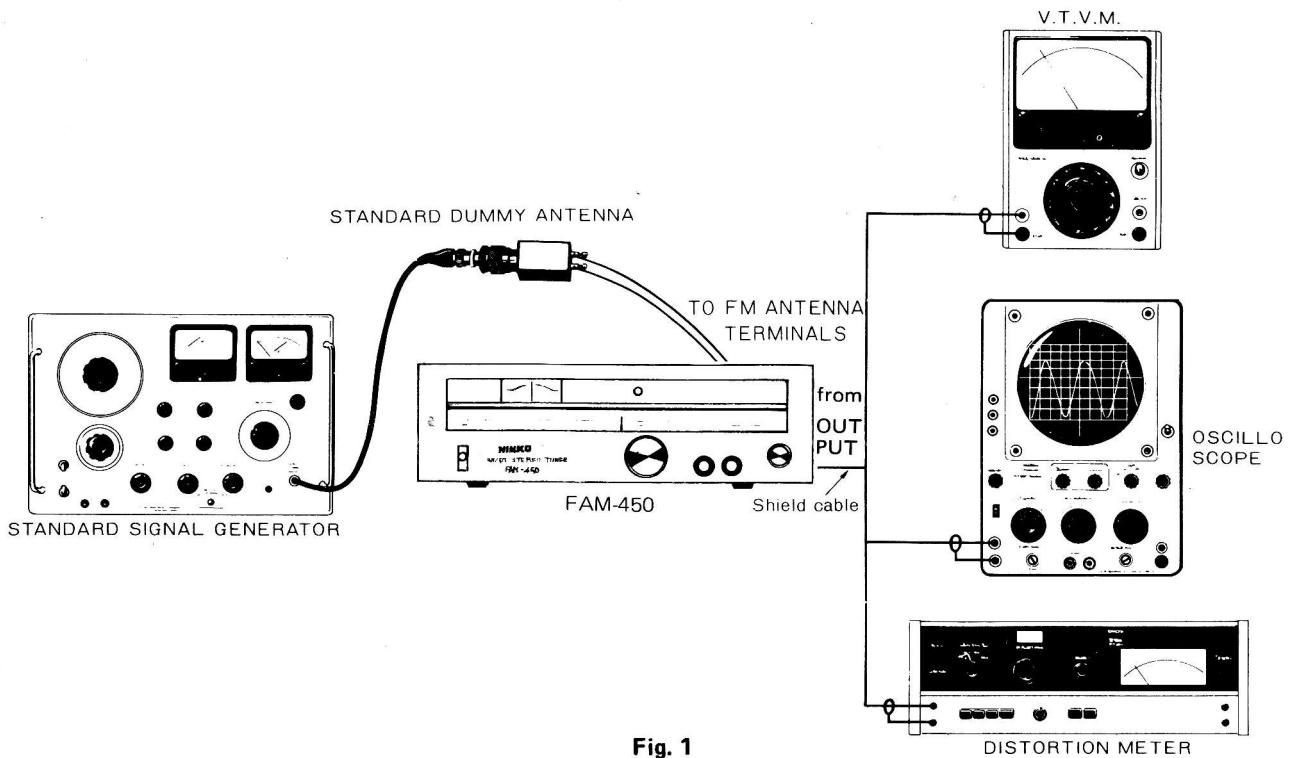

Fig. 1

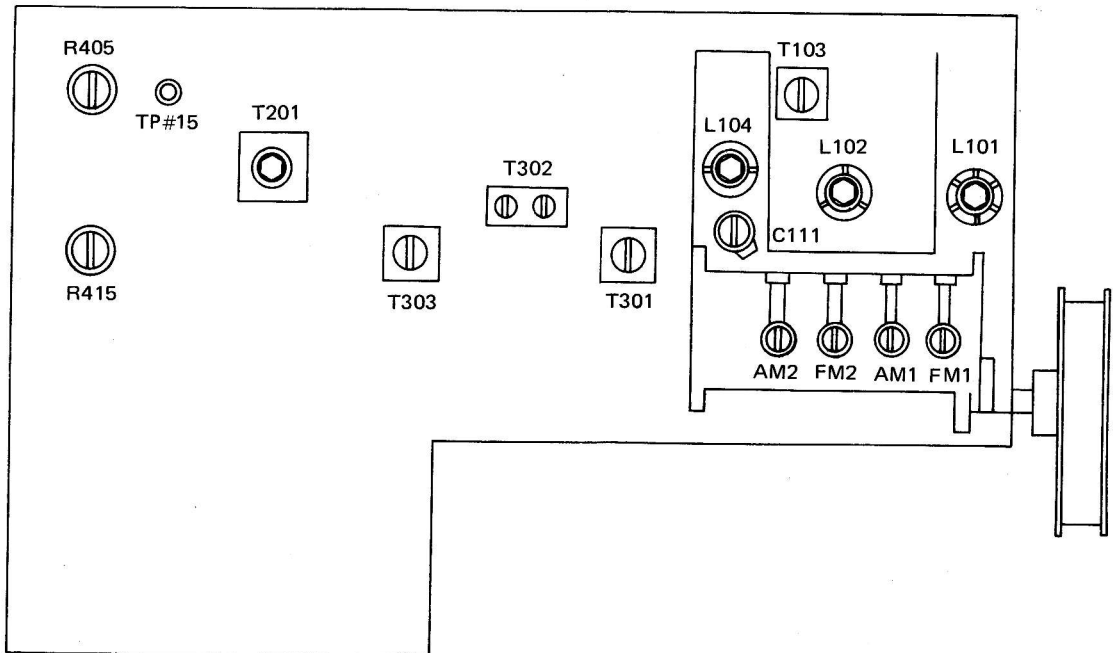

Fig. 2

2. FM-IF STAGE ADJUSTMENT

For adjustment of the discriminator coil T201, connect the testing instruments as shown in Fig. 1 and then proceed as follows:

- (1) With no RF signal applied to the receiver, adjust the lower core of T201 until the pointer of the tuning meter on the receiver indicates the center position of the meter scale.
- (2) Apply RF signal to the receiver and adjust the tuning knob so that the tuning meter indicates the center position.
- (3) Under this condition, adjust the upper core of T201 for minimum distortion.
- (4) Repeat the above steps (1) through (3) two or three times so that the distortion factor is most improved.

Note: For adjusting point, refer to Fig. 2.

3. FM SEPARATION ADJUSTMENT

With stereo-modulated RF signal applied to the receiver, make adjustment as follows:

- (1) Turn the semi-fixed resistor R415 (150K ohm) fully clockwise.
- (2) Connect a frequency counter to the test point #15 on the Tuner PCB Assy Board. Adjust the semi-fixed resistor R405 (10K ohm) for the frequency of $19 \text{ KHz} \pm 19 \text{ Hz}$.
- (3) Adjust the semi-fixed resistor R415 (150K ohm) for maximum stereo separation.

Note: For adjusting point, refer to Fig. 2.

AM SECTION

1. FREQUENCY COVERAGE AND TRACKING ADJUSTMENT

The following is intended to describe the procedure of adjusting the AM section of the receiver using a sweep generator.

In the adjustment, the output voltage is applied through inductive coupling.

For adjustment, place a loop antenna near the receiver under test and observe the waveform of detector output (at the point #22 on the Tuner PCB Assy Board) displayed on the alignment oscilloscope.

For adjustment point, refer to Fig. 2.

The waveform displayed on the alignment oscilloscope is as shown in Fig. 3.

Step	Generator and Dial Freq.	Adjust	Indication and Remarks
1	520 KHz	T301	Oscillator coil core adjust for maximum reading
2	1650 KHz	AM2	Oscillator trimmer adjust for maximum reading
3	600 KHz	AM BAR ANT.	Antenna coil adjust for maximum reading
4	1400 KHz	AM1	Antenna trimmer adjust for maximum reading
5	Repeat steps 1–4 to obtain best tracking		

2. AM-IF STAGE ADJUSTMENT

This adjustment is similar to the frequency coverage and tracking adjustment. Switch the sweep generator from RF to IF and follow the procedure below.

The adjusting procedure is as follows:

- (1) With the receiver set to a high receiving frequency (variable capacitor in full open position), adjust T302 and T303 until the IF waveform becomes maximum.
- (2) If, in this case, the adjustment is difficult because of disturbing signal, the variable capacitor may be turned to facilitate the adjustment.
- (3) The waveform displayed on the alignment oscilloscope is as shown in Fig. 4. For adjusting position, refer to Fig. 2.

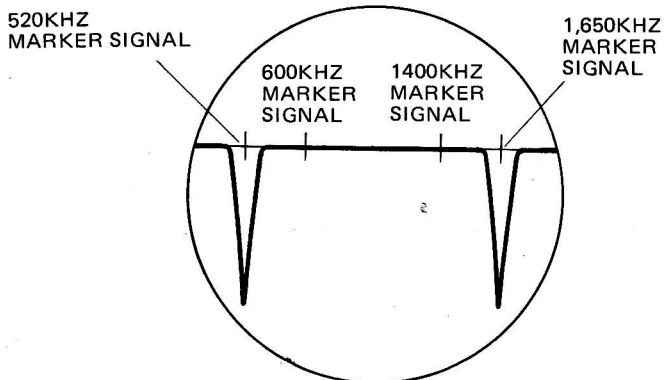

Fig. 3

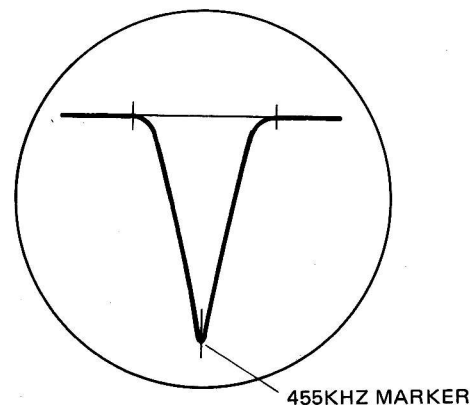
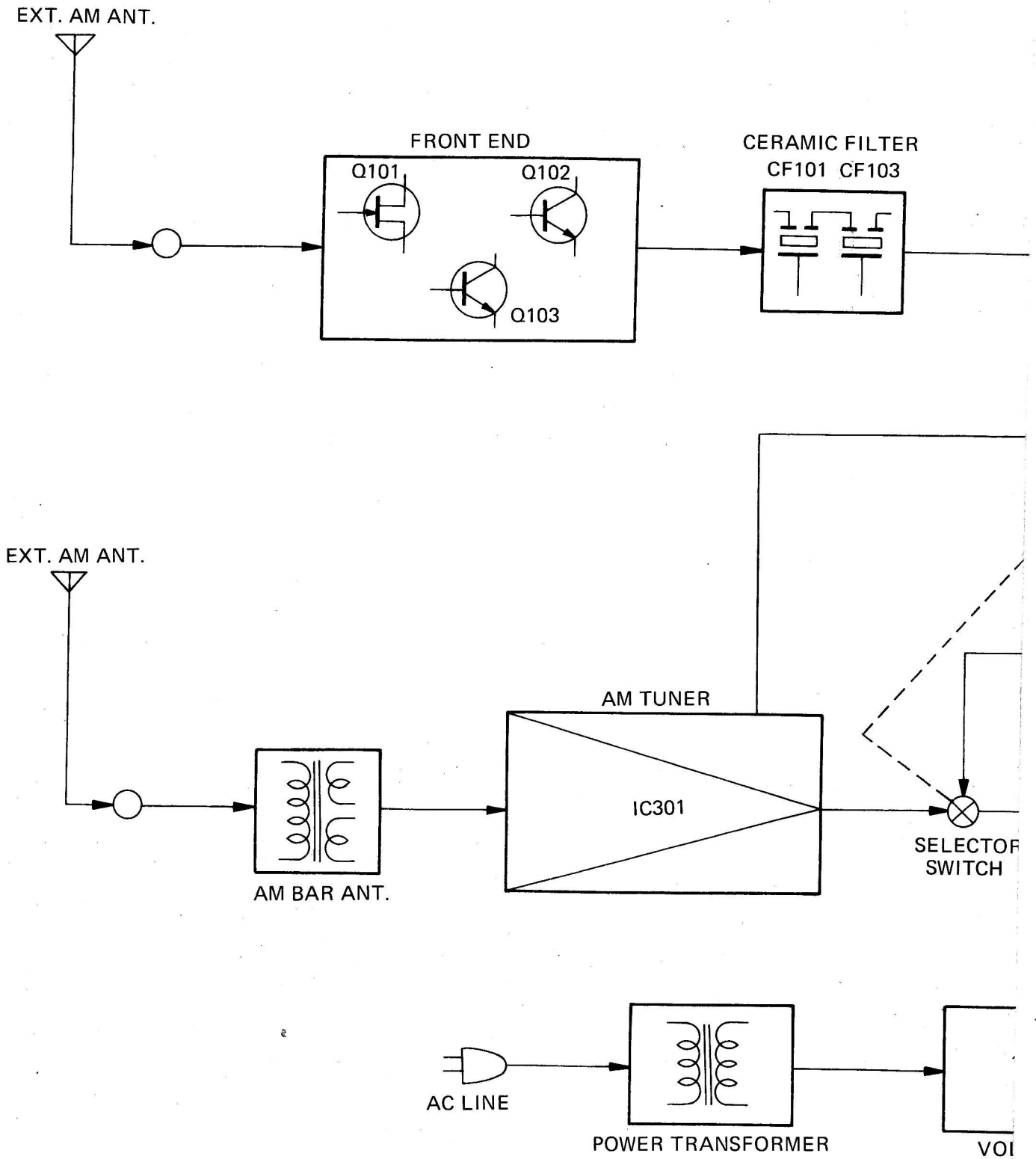

Fig. 4

BLOCK DIAGRAM MODEL FAM-450



FM IF AMP.

IC201

DISC COIL

FM MUTING SW.

SIG./TUNING METER

FM MPX

IC401

OUT PUT

HI-BLEND SW.

POWER SUPPLY

LT STAB.

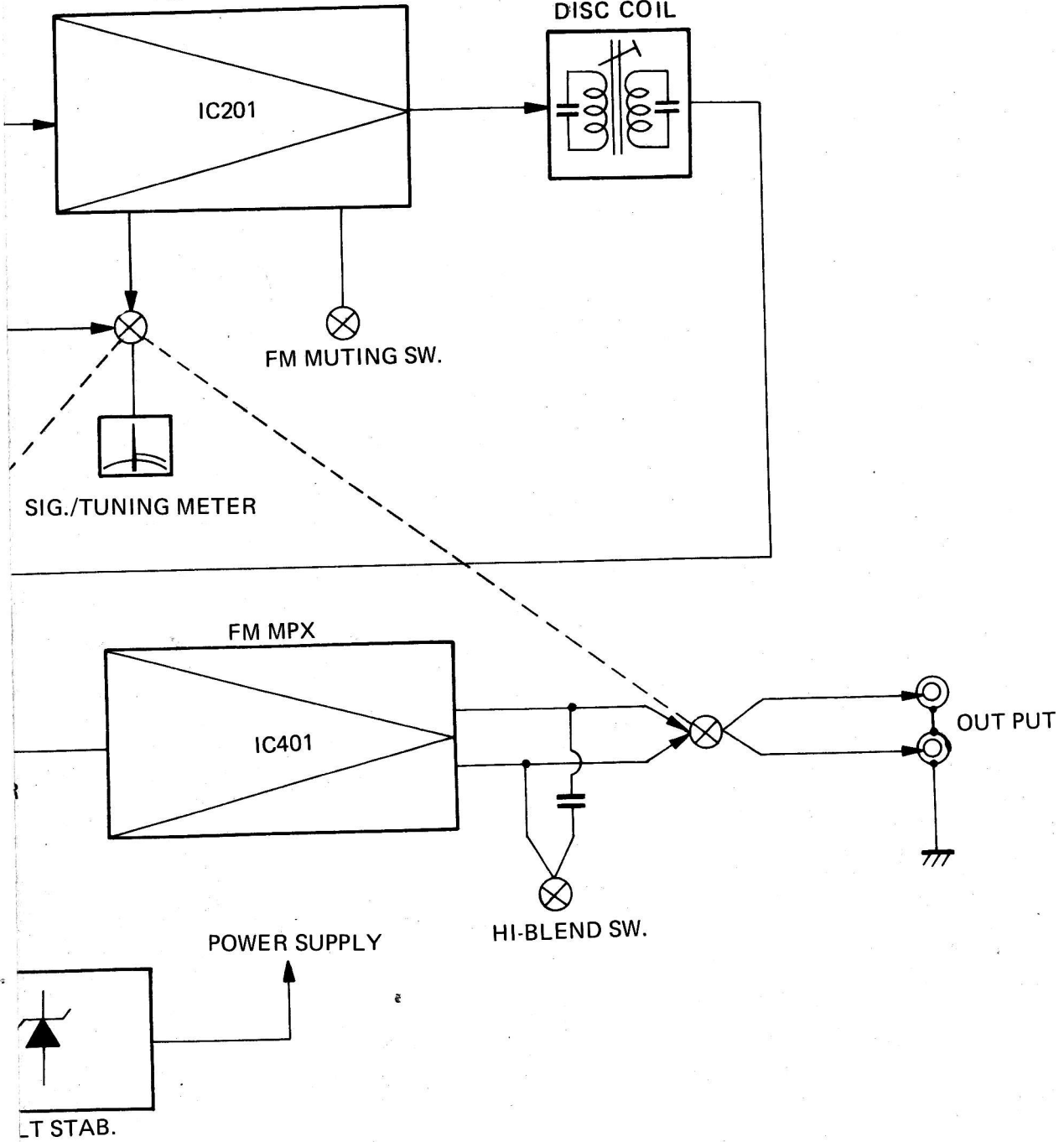

OVERALL DIAGRAM MOD

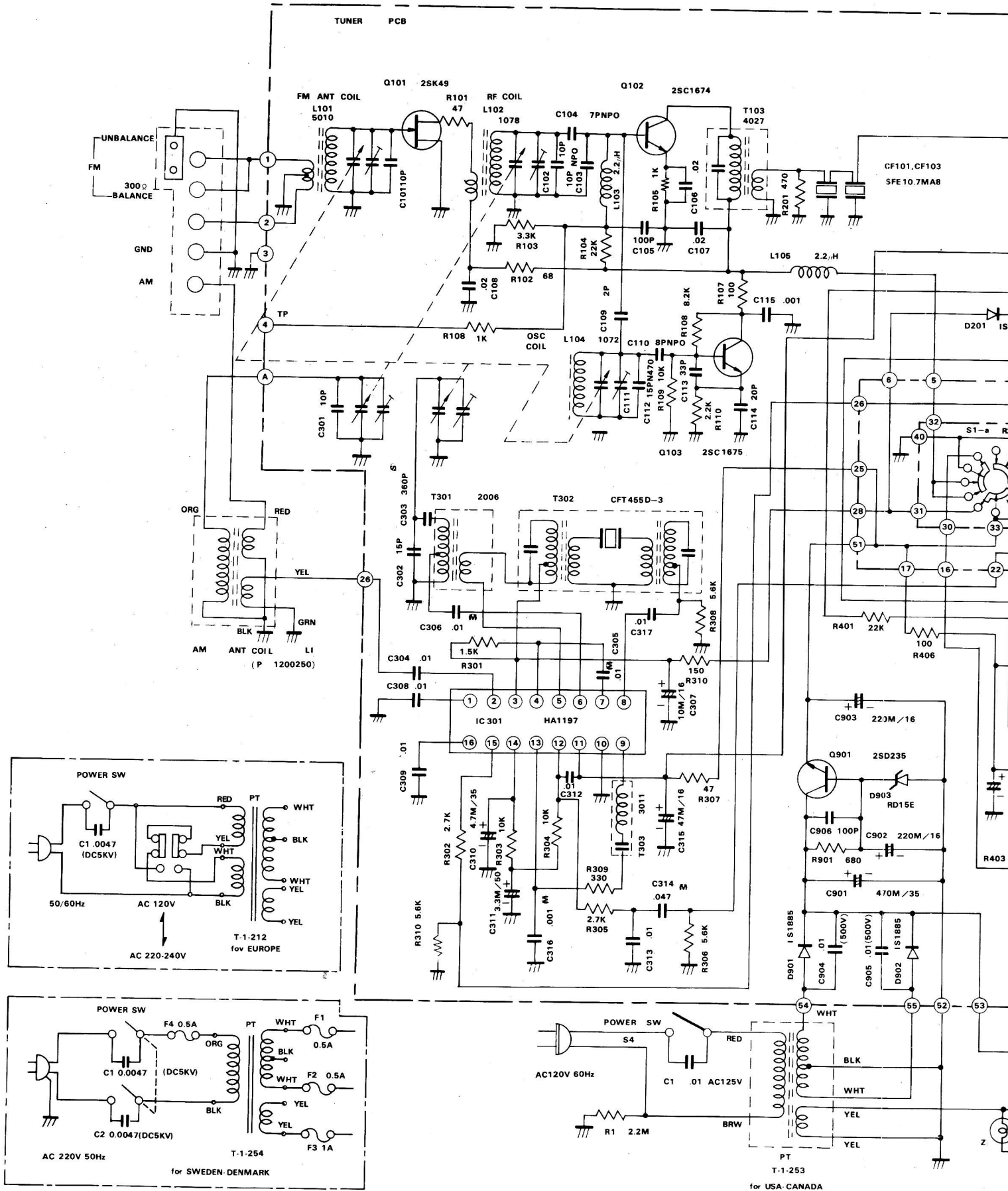
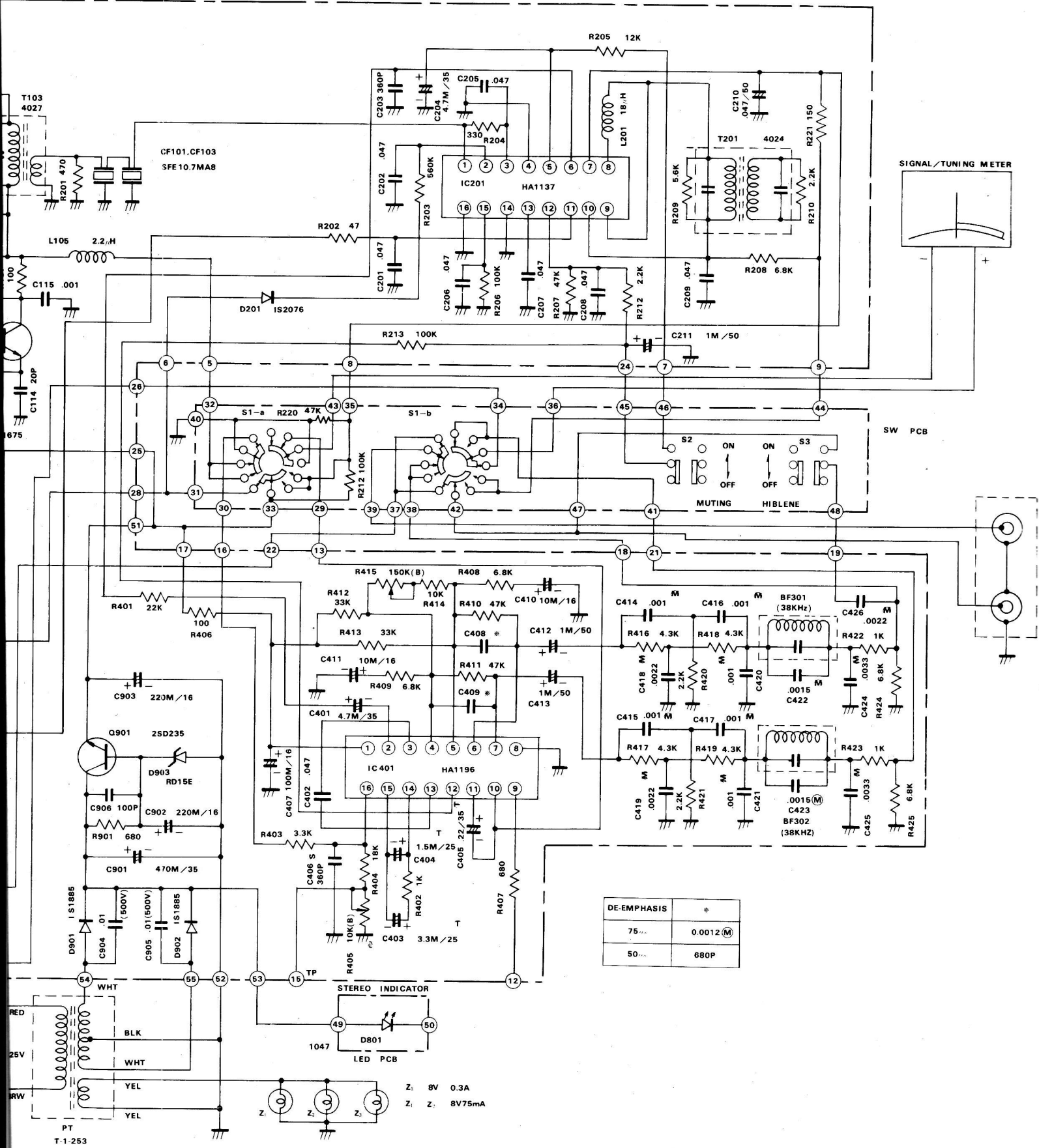

DIAGRAM MODEL FAM-450



DE-EMPHASIS	+
75...	0.0012 (M)
50...	680P

INTEGRATED CIRCUIT COMPLEMENT SPECIFICATION

Type	Class of Service	Maximum Ratings (TA=25°C)				Electrical Characteristics (Typical Value) TA=25°C					
		Power Supply Vcc (V)	Power Dissipation Pd. (MW)	Operating Temp. Range T _{opt} (°C)	Storage Temp. Range T _{stg} (°C)	Signal to Noise Ratio Input=74dBμ Mod.=30% (dB)	Distortion Input=74dBμ Mod.=30% (%)	Detector Output Input=74dBμ Mod.=30% (mV)	AGC. FOM Input: 100dBμ=0dB	Power Consumption Vcc=12V (mA)	Manufacture
HA1197	AM RADIO	15	450	-20~+70	-55~+125	53	0.4	212	75	14.5	HITACHI

CONNECTION DIAGRAM (TOP VIEW)

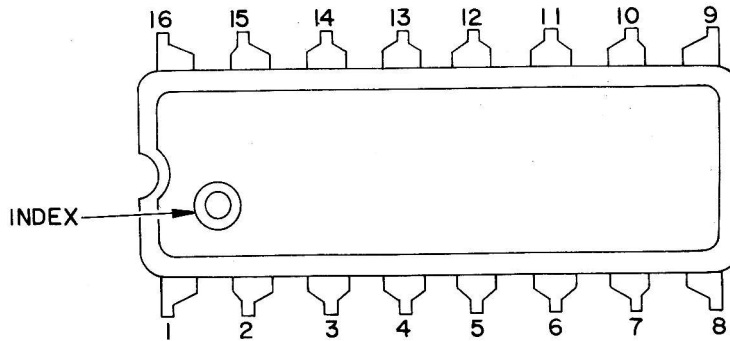

SCHEMATIC DIAGRAM

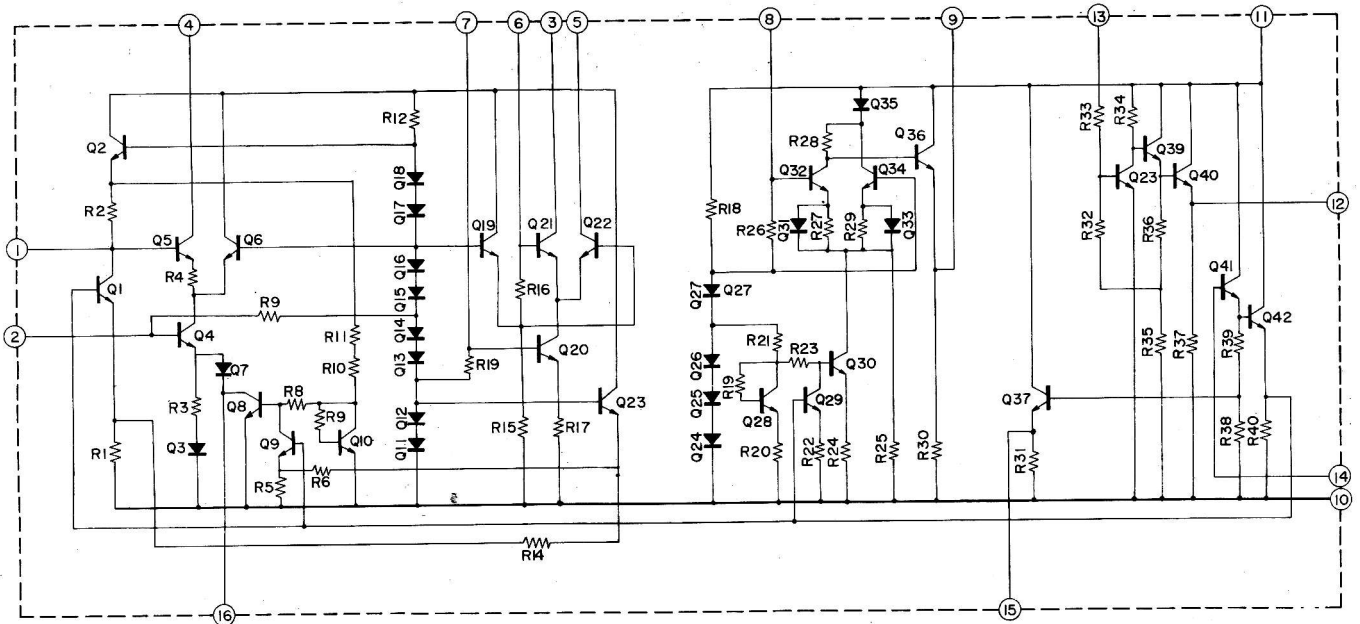

INTEGRATED CIRCUIT COMPLEMENT

Type	Class of Service	Maximum Rating $T_A=25^\circ\text{C}$					Electrical Characteristics (Typical Value) $T_A=25^\circ\text{C}$						Manufacture
		Power Supply	Power Dissipation	Input Voltage	Operating Temp. Range	Storage Temp. Range	Power Consumption	Input Limiting Sensitivity	Detector Output	Distortion	Signal to Noise Ratio	AM Rejection Ratio	
		V_{CC} (V)	P_d (mw)	V_{IN} (V)	T_{opt} ($^\circ\text{C}$)	T_{stg} ($^\circ\text{C}$)	$V_{CC}=13\text{V}$ (mA)	μV (-3dB point)	(mV)	(%)	(dB)	(dB)	
HA1137W	FM-IF Quadrature-Detector Audio-Preamp.	14	550	1.9	-20~+60	-55~+125	32	15	300	0.1	MIN. 57	45	HITACHI

CONNECTION DIAGRAM (TOP VIEW)

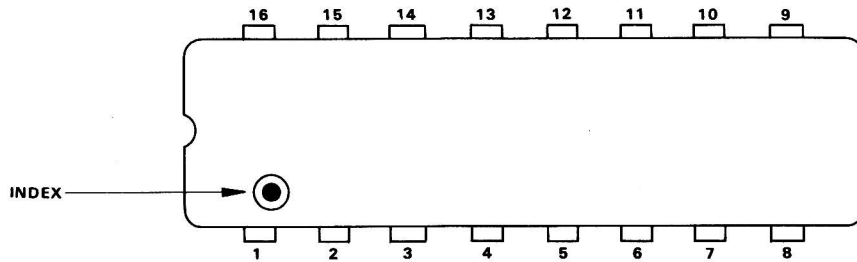

SCHEMATIC DIAGRAM

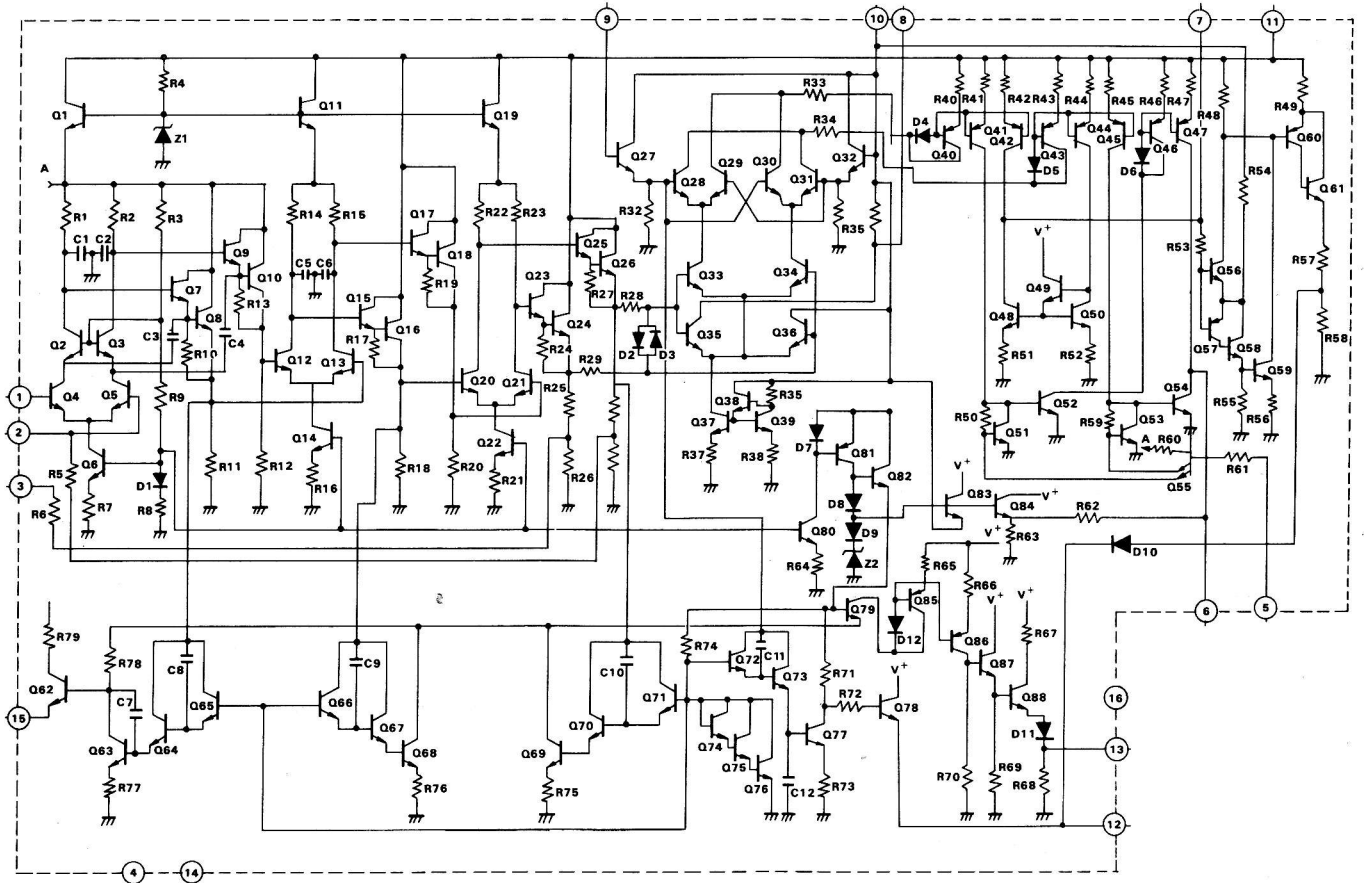

INTEGRATED CIRCUIT COMPLEMENT SPECIFICATION

Type	Class of Service	Maximum Ratings (TA=25°C)					Electrical Characteristics (Typical Value) TA=25°C						Manufacture
		Power Supply Vcc (V)	Power Dissipation Pd. (mw)	Lamp Driver I _L (mA)	Operating Temp. Range T _{opt} (°C)	Storage Temp. Range T _{stg} (°C)	Input Impedance Z _{in} (KΩ)	Stereo Separation (dB)	Channel Balance (dB)	Distortion (Stereo) (%)	Lamp Level (mV)	Output Voltage Input =2-mV (mV)	
HA1196	FM STEREO DEMODULATOR	15	490	75	-20 ~ +70	-55 ~ +125	75	50 (at 1 KHz)	±1.5	0.1 (at 1 KHz)	MIN 4.0	1.2V	HITACHI

CONNECTION DIAGRAM (TOP VIEW)

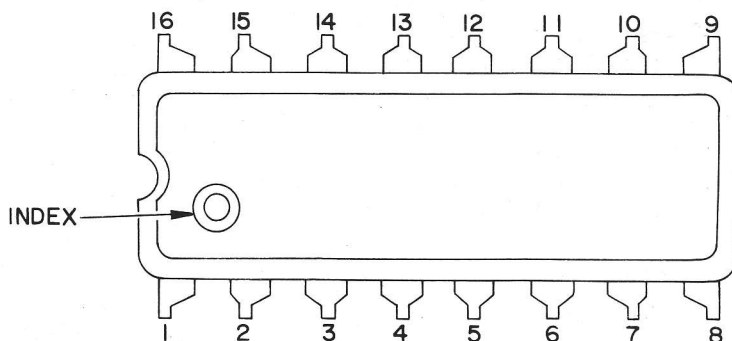

SCHEMATIC DIAGRAM

