

NIKKO

AMPLIFIER

IA 600

IA 400

INTEGRATED AMPLIFIER

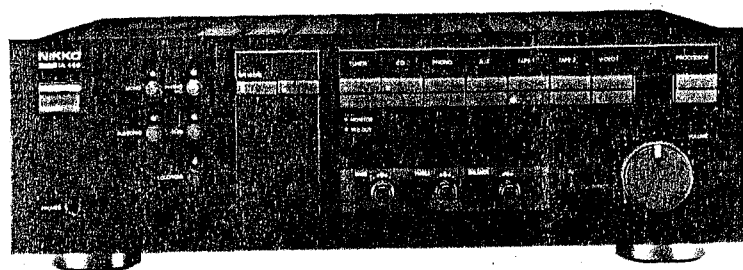
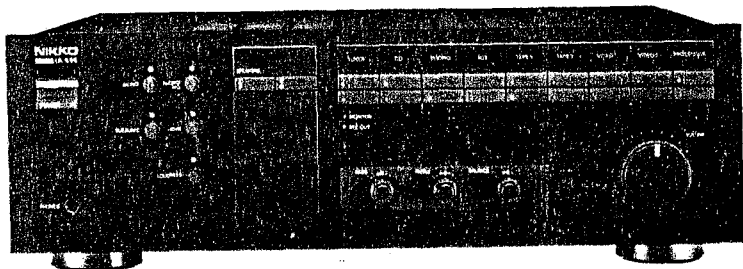

SERVICE MANUAL

CONTENTS

SAFETY INSTRUCTIONS	1
SPECIFICATIONS	1
BLOCK DIAGRAM	2
ALIGNMENT	3
CIRCUITS DATA	4 ~ 6
PCB	7 ~ 10
SCHEMATIC DIAGRAM	11 ~ 20
WIRING DIAGRAM	21, 22
EXPLODED VIEWS	23, 24
PARTS LIST	25 ~ 27

SAFETY INSTRUCTIONS

PRECAUTIONS DURING SERVICING

1. Parts identified by the \triangle symbol parts are critical for safety. Replace only with same parts number specified.
2. Other parts and assemblies are specified to conform with such regulations as those applying to spurious radiation.
These must also be replaced only with specified replacements.
Examples: RF converters, tuner units, RF cables, noise blocking capacitors, noise blocking filters, etc.
3. Use specified internal wiring
 - a) Primary leads
 - b) Wires covered with PVC tubing
 - c) Double insulated wire
4. Use specified insulating materials for hazardous live parts.
 - a) Insulation Tape
 - b) Insulated Barriers (Spacers)
 - c) PVC tubing
 - d) Plastic screws for fixing microswitch (Especially in turntable)
 - e) Terminal strips

5. When replacing the primary components (transformer, power supply cord switch, by-pass capacitor, etc.), wrap ends of wires securely about the terminals before soldering.

Where hand soldering is involved, a minimum spacing below between terminals of uninsulated live parts of primary or supply circuitry through air or over surface is to be maintained.

120V appliance : 3mm spacing min.
220V and 240V appliance : 6mm spacing min.

6. Observe that wires do not contact heat producing parts (heatsinks, oxide metal resistance, rectifiers, etc.)
7. Check that replaced wires do not contact sharp edges or pointed parts.
8. Do not leave electric conductive parts (screws, droplets, etc.) inside the appliance.

SAFETY RECHECK AFTER SERVICING

Confirm the specified insulation resistance between power plug prongs and externally exposed parts of the appliance is greater than 10Mohms, however, for equipment with external antenna terminals (tuner, receiver, etc.) specified insulation resistance should be more than 2.2Mohms (ground terminals, in-output jacks etc.).

SPECIFICATIONS

Amplifier Section

Rated Power Output

Min. RMS power per channel into 8 ohms
from 20Hz to 20kHz at 0.01% T.H.D.,
both channels driven 120W+120W (IA 600)
Min. RMS power per channel into 8 ohms
from 20Hz to 20kHz at 0.009% T.H.D.,
both channels driven 80W+80W (IA 400)

Both Channels Driven
at 4 ohms, 1kHz, (DIN) 210W+210W (IA 600)
130W+130W (IA 400)

Dynamic Power Output

8 ohms 170W (IA 600)
120W (IA 400)
6 ohms 210W (IA 600)
150W (IA 400)
4 ohms 270W (IA 600)
180W (IA 400)

Dynamic Headroom 1.5dB (IA 600)
1.76 dB (IA 400)

Power Bandwidth (T.H.D. 0.03%) 10Hz to 60kHz
Damping Factor (8 ohms) 140 (IA 600)
120 (IA 400)

Total Harmonic Distortion

PHONO to REC OUT 1kHz
MM 0.003%
MC 0.003%
CD (1kHz at 120W) 0.003% (IA 600)
(1kHz at 80W) 0.003% (IA 400)

Input Sensitivity/Impedance

PHONO MM 2.5mV/47kohms
MC 0.25mV/100ohms
CD 140mV/47kohms
TUNER 140mV/47kohms

VIDEO 140mV/47kohms
TAPE 140mV/47kohms
Signal-to-Noise Ratio (IHF-A network)
PHONO MM (INPUT 5mV) 94dB
MC (INPUT 0.5mV) 81dB (IA 600)
80dB (IA 400)
CD, TUNER, TAPE 105dB
MAIN IN 125dB (IA 600)
120dB (IA 400)

PHONO Overload level at 1kHz (0.1% T.H.D.)

MM 150mV
MC 15mV

Frequency Response

PHONO (RIAA, REC OUT 150mV)
MM 20Hz to 20kHz + 0dB, -1.5dB
MC 20Hz to 20kHz + 0dB, -1.5dB
CD (at 1W) 5Hz to 100kHz + 0dB, -1.5dB

Tone Controls

BASS ± 10 dB (100Hz)
TREBLE ± 10 dB (10kHz)

SUBSONIC FILTER 15Hz, -12dB/oct.

General

Power Require

U.S.A. & Canada AC 120V, 60Hz
Europe AC 220V, 50Hz

Power Consumption

U.S.A. & Canada 360W, 480VA (IA 600)
300W, 400VA (IA 400)

Dimensions 442(W)x146(H)x413(D)mm
(17-2/5" x 5-3/4" x 16-1/4")

Weight 14.5kg (32lbs)

* Specifications are subject to change without notice.

BLOCK DIAGRAM

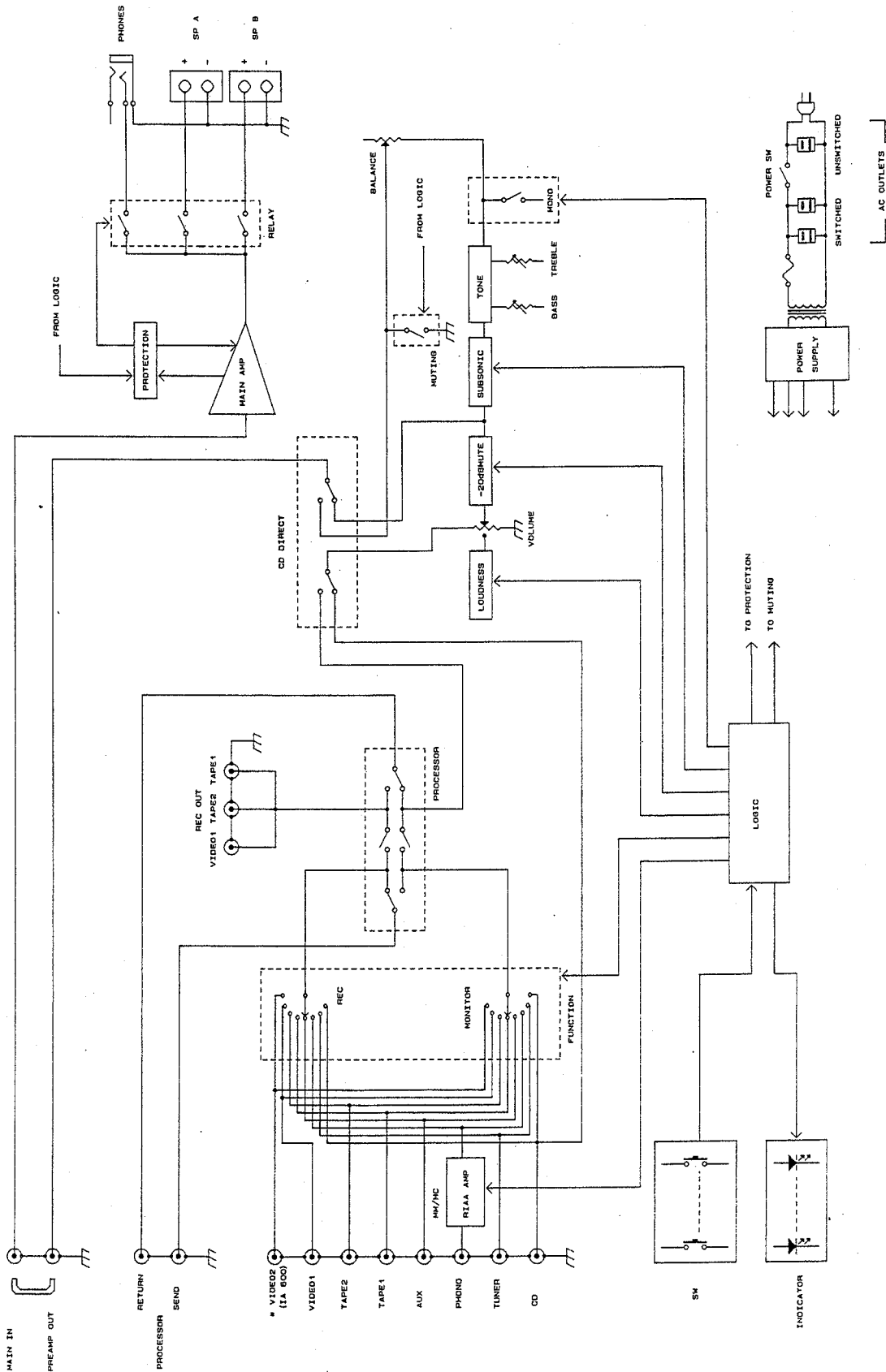

ALIGNMENT

TEST EQUIPMENTS

Allow a minimum of 10 minutes warm-up for test equipment.

Maintain rated line voltage.

- Audio Frequency Generator
- Distortion Meter
- Oscilloscope
- AC Voltmeter
- DC Voltmeter

IDLING CURRENT ADJUSTMENT

1. Connect the DC voltmeter to the test points.
2. Turn the VOLUME control knob down to the fully counter clockwise.
3. Turning on the power button of the IA600/400.
4. Allow a minimum of 1 minute warm-up for the amplifier.
5. Adjust the trimmer potentiometer VR503 (left channel) or VR504 (right channel) so that the DC voltmeter indicates $10\text{mV} \pm 1\text{mV}$.
6. Turn off the power button of the IA600/400 and remove the DC voltmeter.

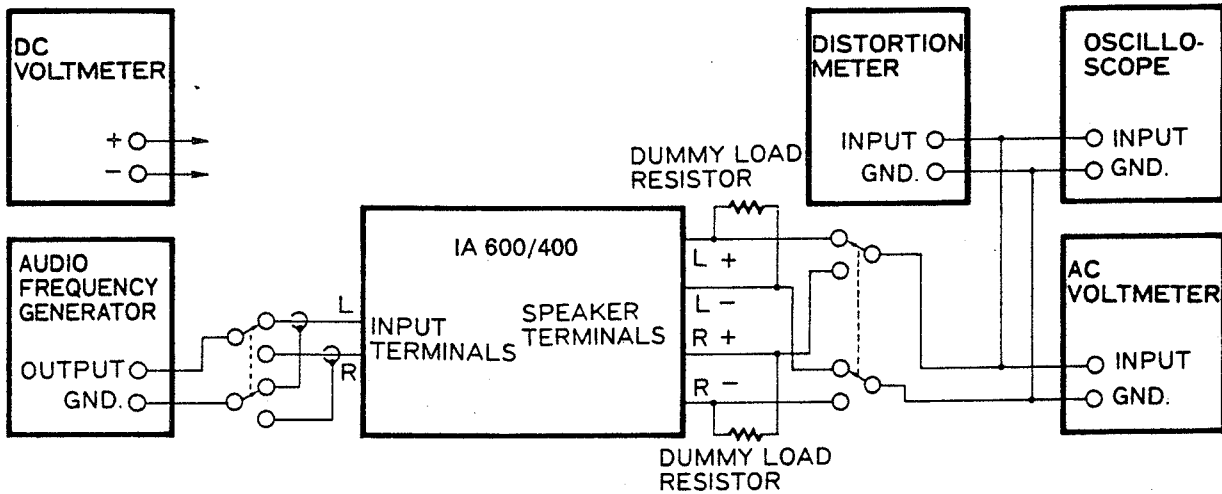

Figure 1 Test Equipment Hook-Up

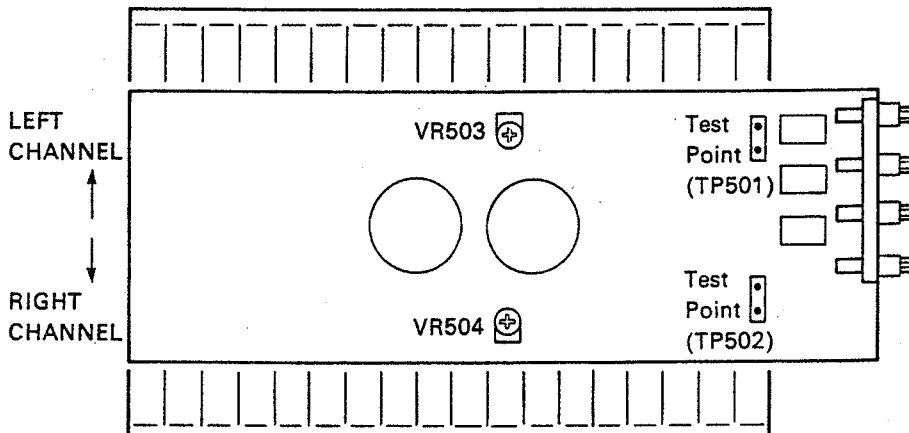
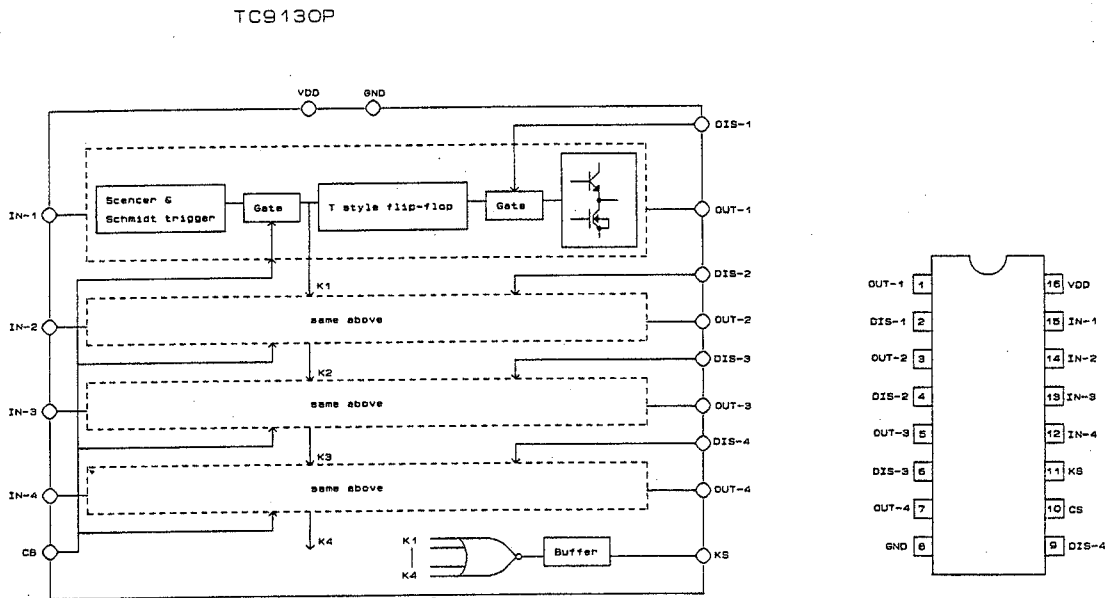
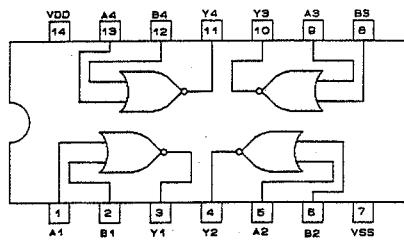
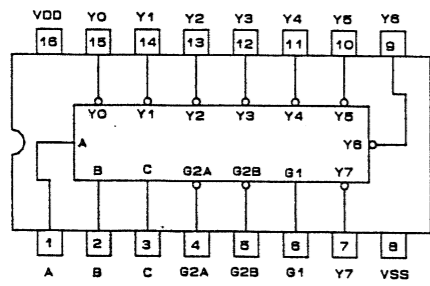

Figure 2 Adjustment Points

CIRCUITS DATA

INTEGRATED CIRCUIT TC9130P
Quad T-style Flip-Flop/TOSHIBAINTEGRATED CIRCUIT μ PD4001BC
Quad 2-Input NOR Gate/NEC

INTEGRATED CIRCUIT μ PD74HC138C
3-to-8 Line Decoder/NEC



INTEGRATED CIRCUIT μ PD74HC148C
8-to-3 Line Priority Encoder/NEC

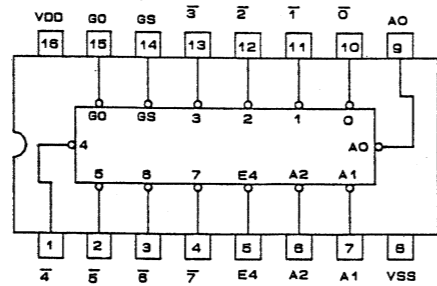

INTEGRATED CIRCUIT μ PD74HC192C
Up/Down Decode Counter/NEC

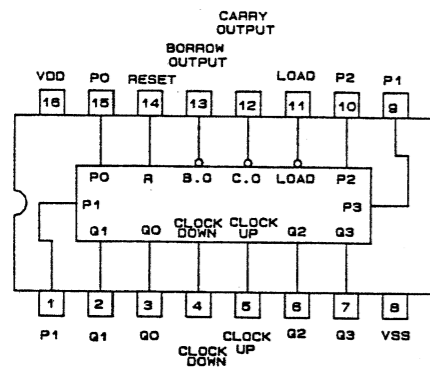

INTEGRATED CIRCUIT LB1245
FL Tube Driver/SANYO

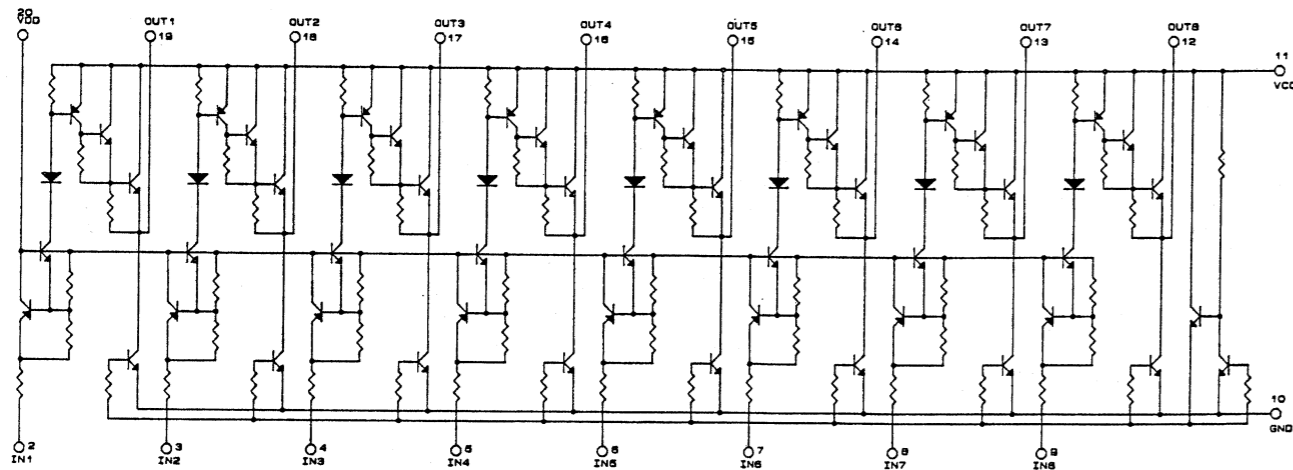

INTEGRATED CIRCUIT μ PC4570HA
Dual Op.Amp./NEC

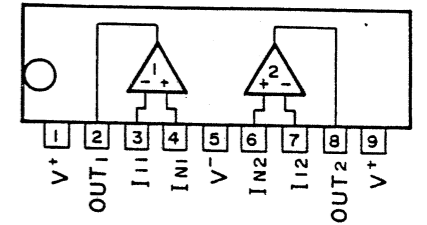
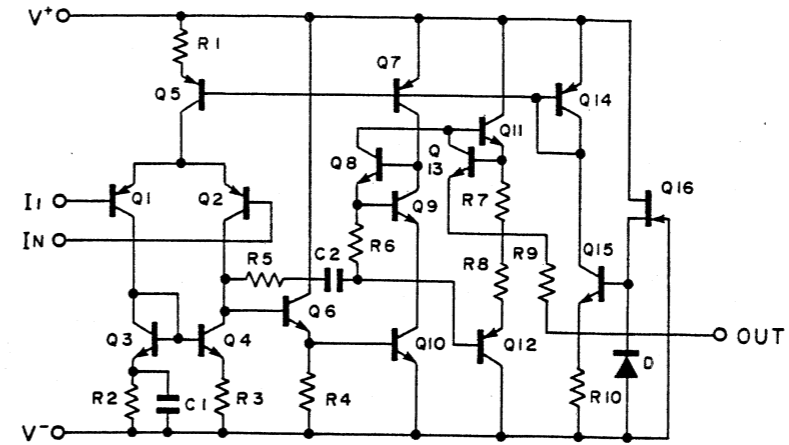

(SIDE VIEW)

INTEGRATED CIRCUIT LC4966
Quad Bilateral Switch/SANYO

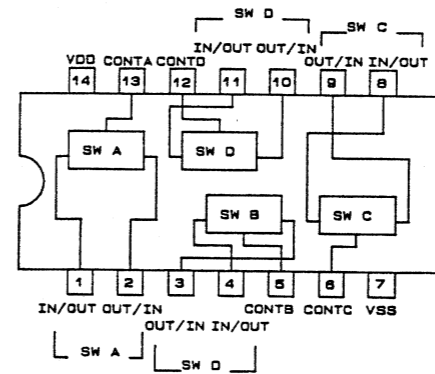

PCB MAIN PCB

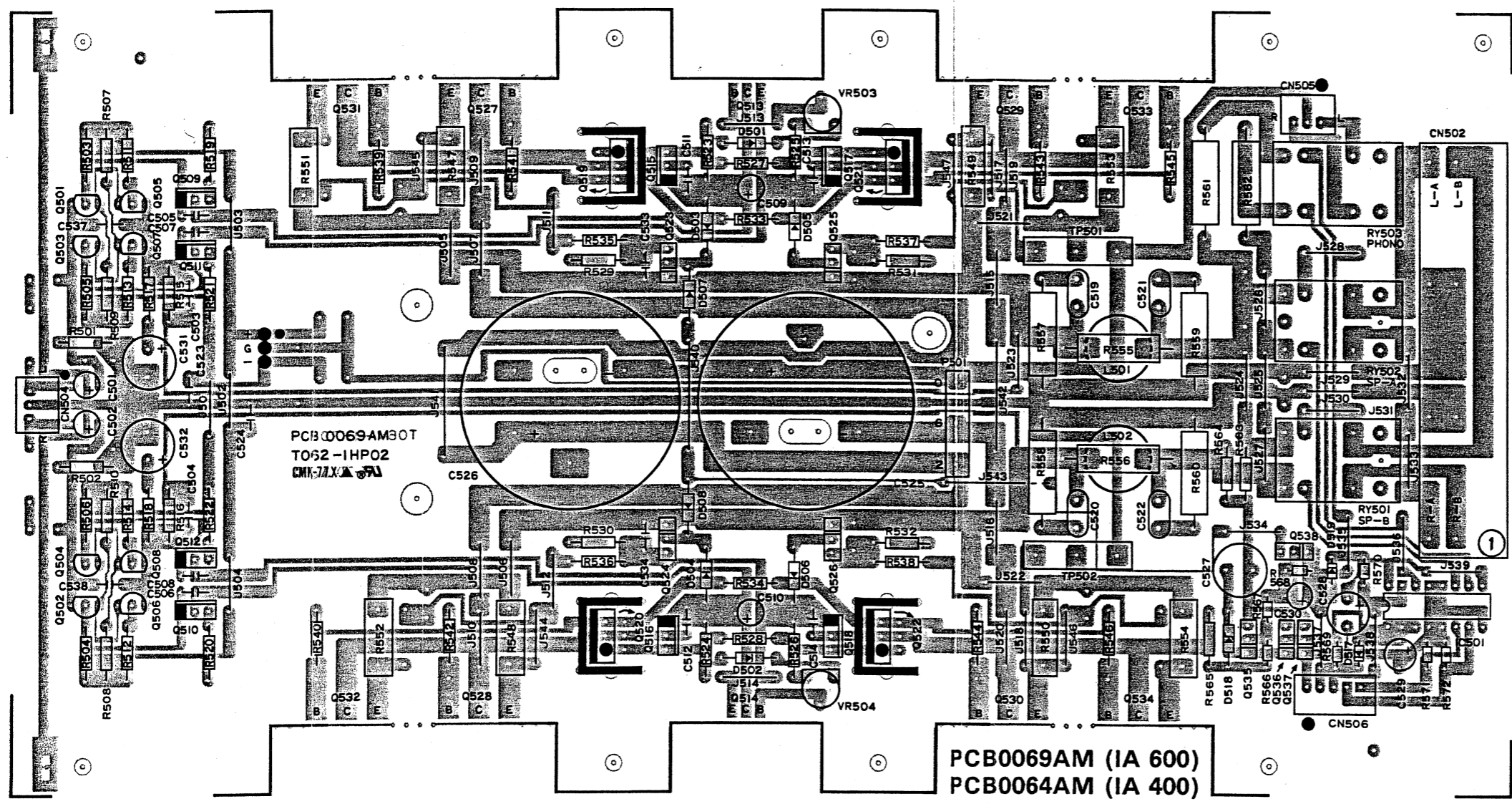

LED PCB
PCB0049AM

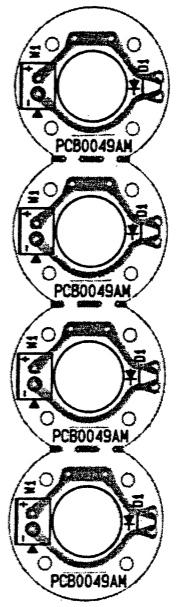

SW PCB

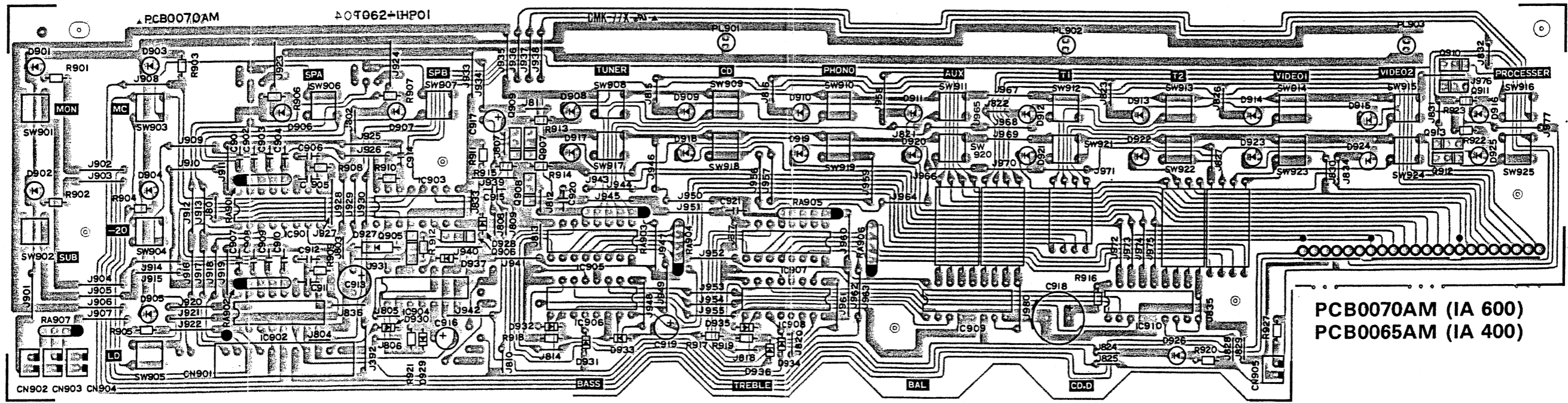

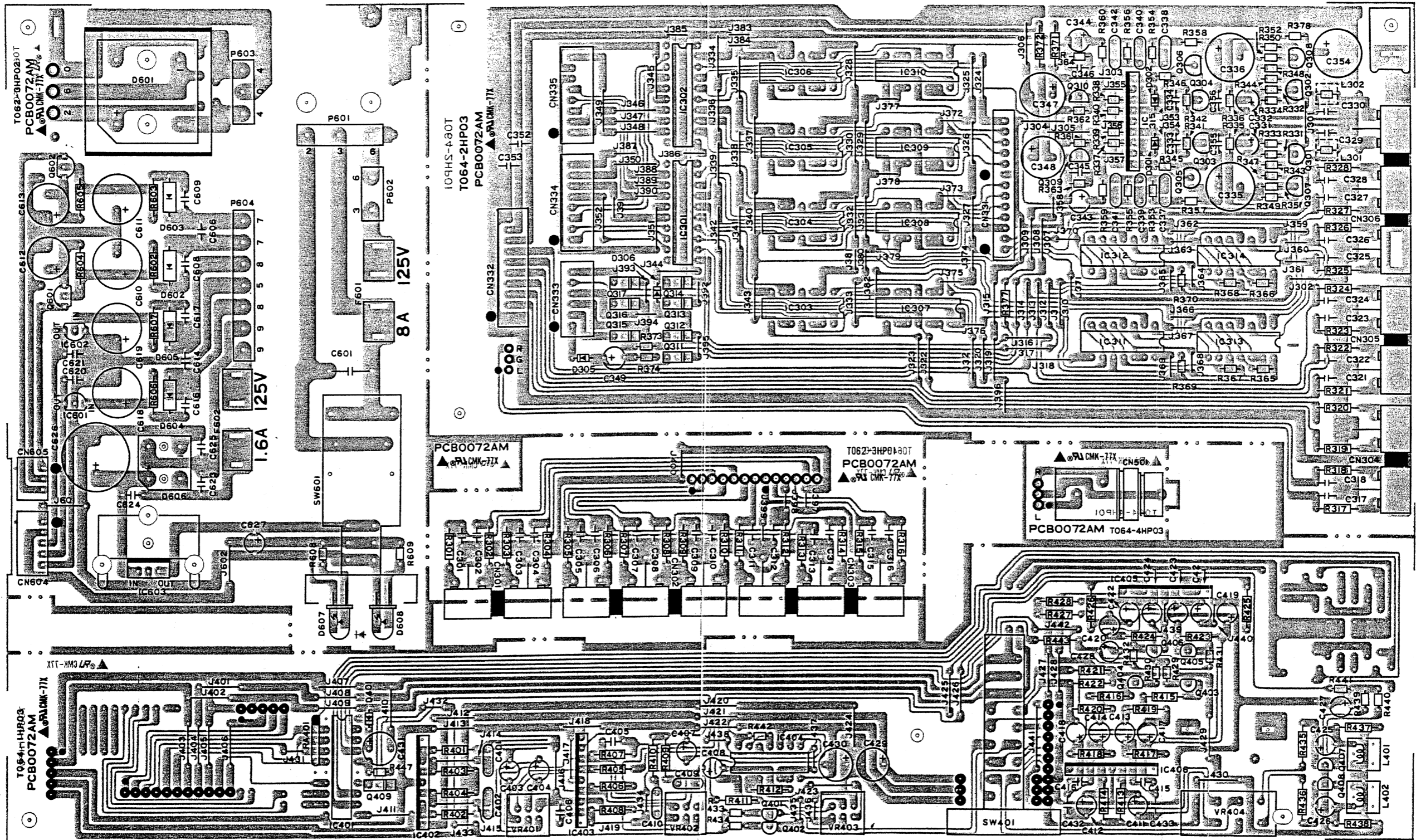

PCB0072AM (IA 600 W/C)
PCB0073AM (IA 600 E/V)
PCB0067AM (IA 400 W/C)
PCB0068AM (IA 400 E/V)

SCHEMATIC DIAGRAM

MAIN PCB (IA600)

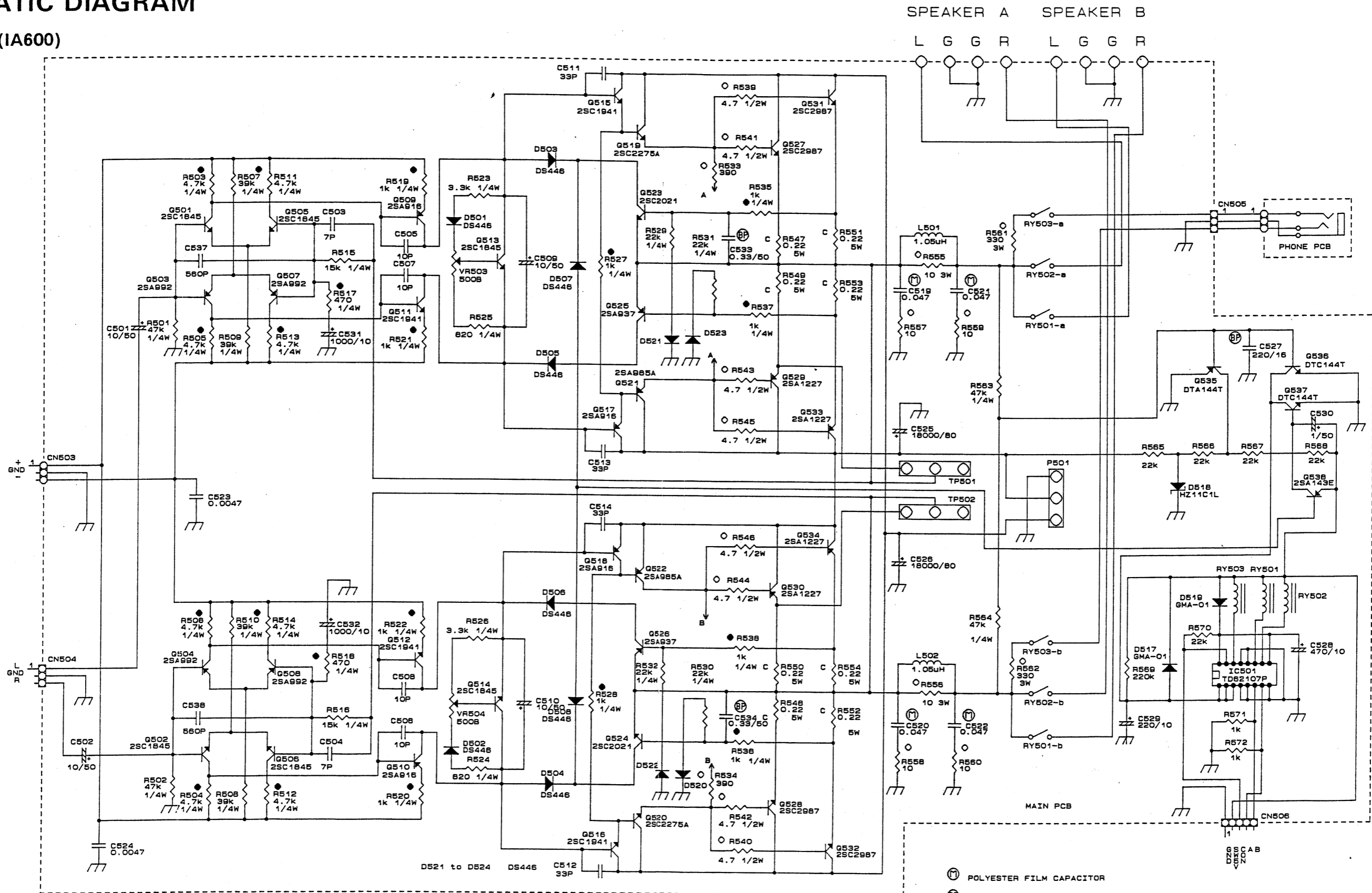

SERVICE INFORMATION

CAUTION: REFER SERVICING TO QUALIFIED SERVICE PERSONNEL.

1. EACH PRECAUTION TO BE FOLLOWED DURING SERVICING.

2. INDICATES SAFETY CRITICAL COMPONENTS. FOR CONTINUED SAFETY, REPLACE SAFETY CRITICAL COMPONENTS ONLY WITH MANUFACTURERS RECOMMENDED PARTS.

3. BEFORE RETURNING THIS APPLIANCE TO THE CUSTOMER, YOU MAKE LEAKAGE-CURRENT OR RESISTANCE MEASUREMENTS TO DETERMINE THAT EXPOSED PARTS ARE ACCEPTABLY INSULATED FROM THE SUPPLY CIRCUIT.

POLYESTER FILM CAPACITOR

BIPOLAR ELECTROLYTIC CAPACITOR

METAL OXIDE FILM FIXED RESISTOR

FLAME PROOF CARBON FILM FIXED RESISTOR

CEMENTED WIREWOUND FIXED RESISTOR

UNSPECIFIED FIXED RESISTORS ARE 1/6W

* SCHEMATIC IS SUBJECT TO CHANGE, WITHOUT NOTICE.



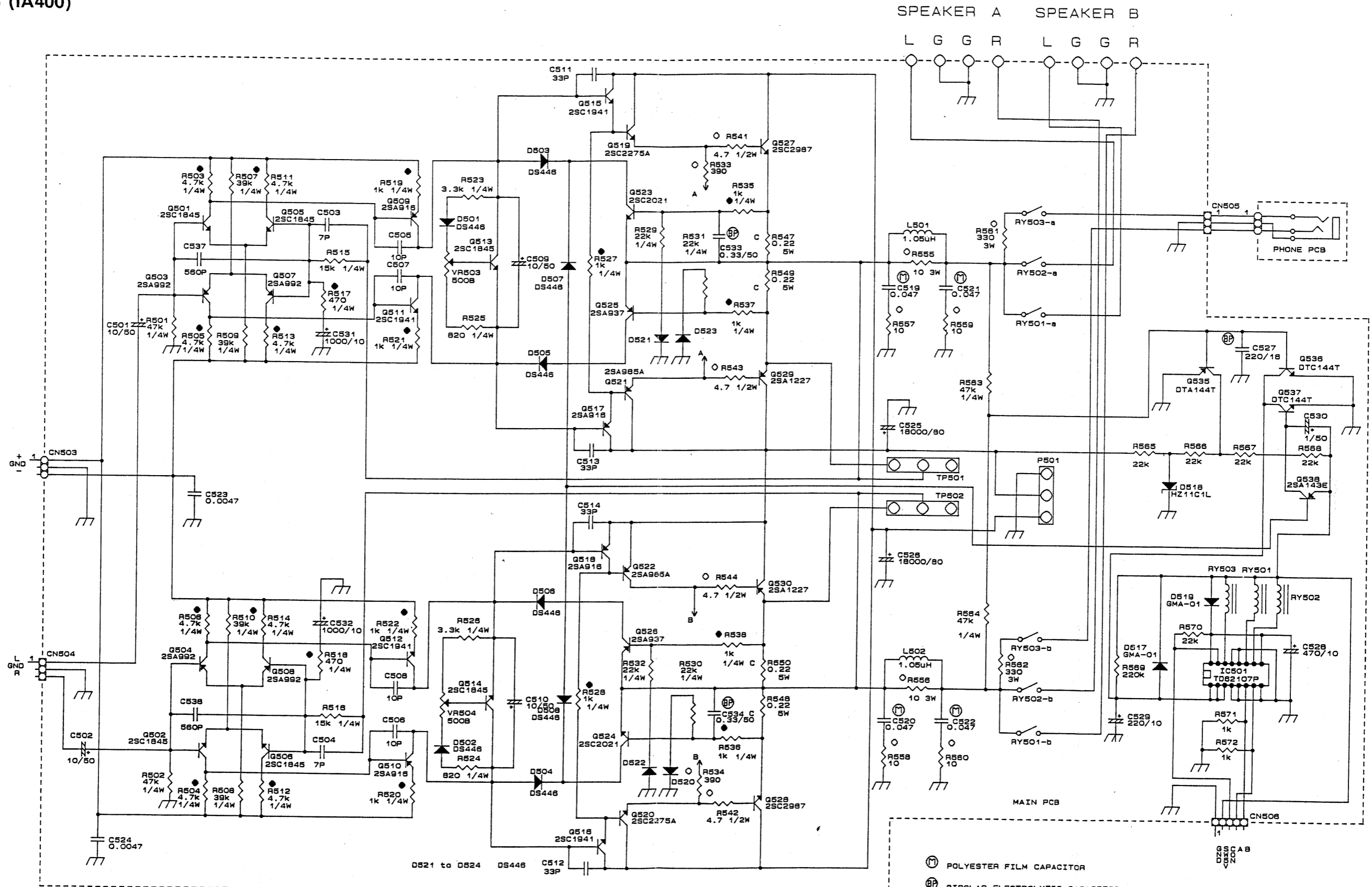

MAIN PCB (IA400)



SERVICE INFORMATION

CAUTION: REFER SERVICING TO QUALIFIED SERVICE PERSONNEL.

1. EACH PRECAUTION TO BE FOLLOWED DURING SERVICING.
2.  INDICATES SAFETY CRITICAL COMPONENTS. FOR CONTINUED SAFETY, REPLACE SAFETY CRITICAL COMPONENTS ONLY WITH MANUFACTURERS RECOMMENDED PARTS.
3. BEFORE RETURNING THIS APPLIANCE TO THE CUSTOMER, YOU MAKE LEAKAGE-CURRENT OR RESISTANCE MEASUREMENTS TO DETERMINE THAT EXPOSED PARTS ARE ACCEPTABLY INSULATED FROM THE SUPPLY CIRCUIT.

-  POLYESTER FILM CAPACITOR
-  BIPOLAR ELECTROLYTIC CAPACITOR
-  METAL OXIDE FILM FIXED RESISTOR
-  FLAME PROOF CARBON FILM FIXED RESISTOR
-  CEMENTED WIREWOUND FIXED RESISTOR

UNSPECIFIED FIXED RESISTORS ARE 1/8W

* SCHEMATIC IS SUBJECT TO CHANGE WITHOUT NOTICE.

FUNCTION PCB (IA600, IA400)

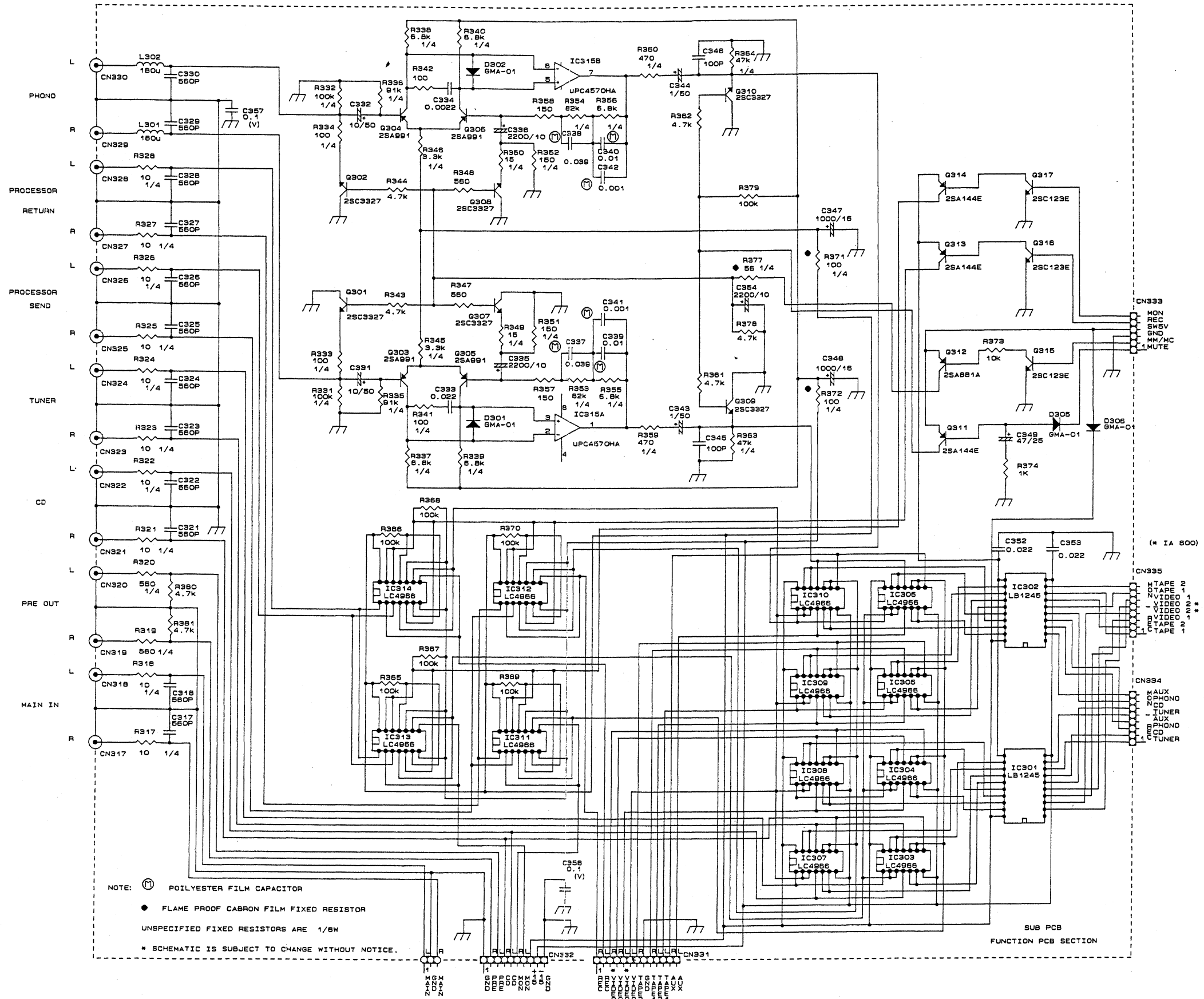

TONE PCB (IA600, IA400)

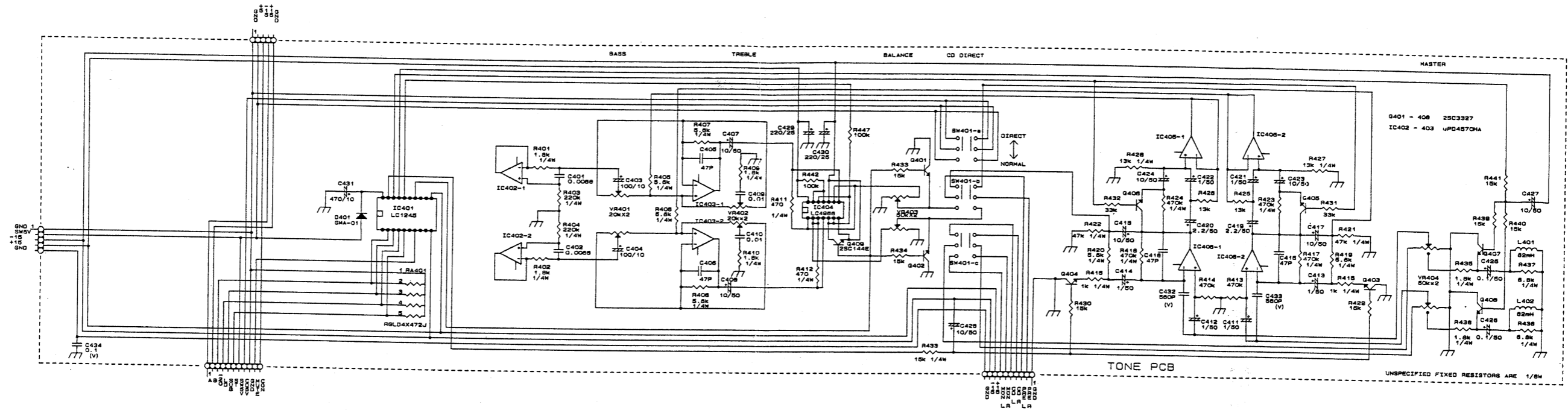

SW PCB (IA600, IA400)

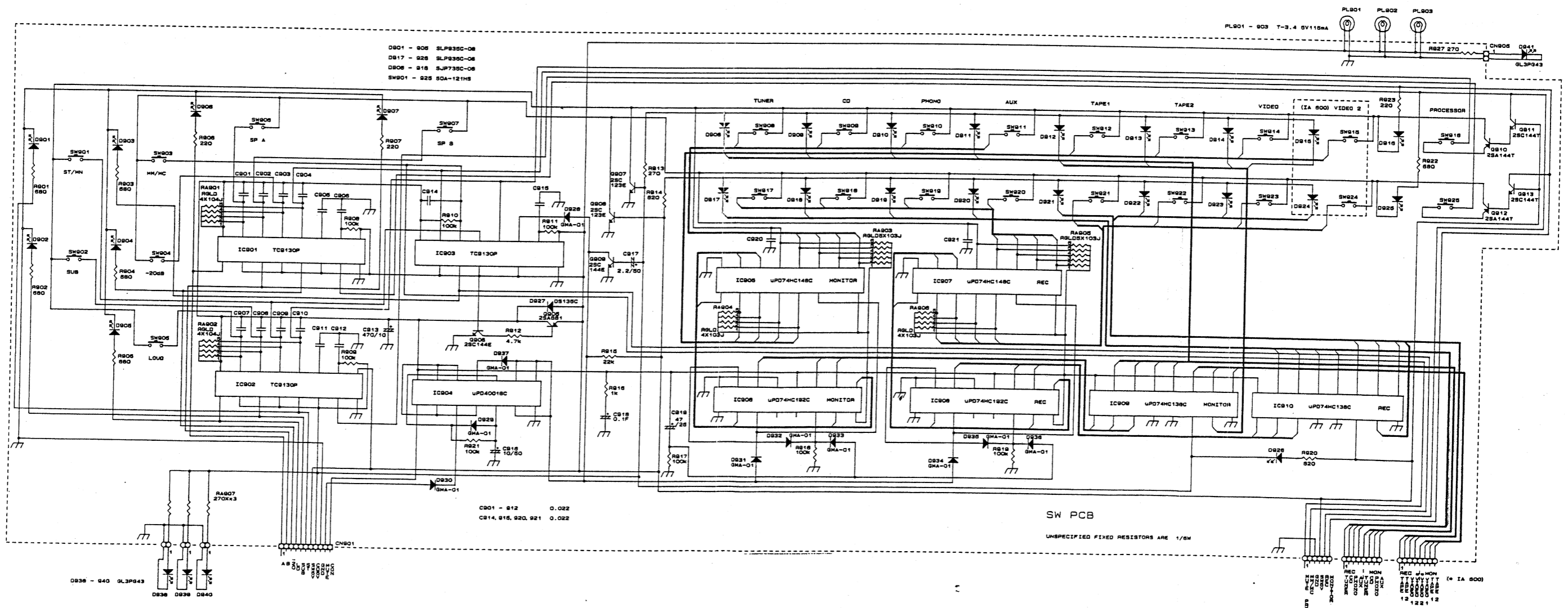

RCA PCB (IA600)

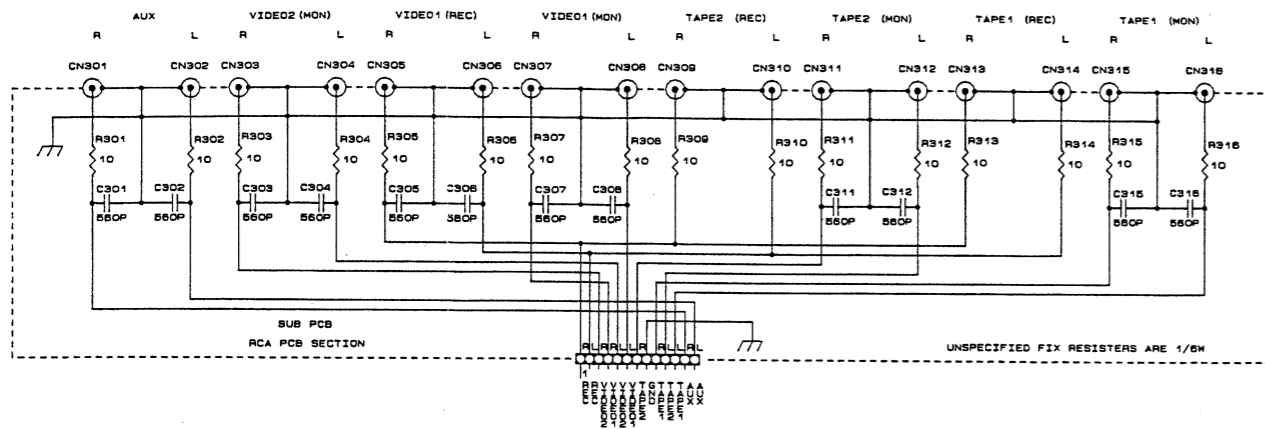

RCA PCB (IA400)

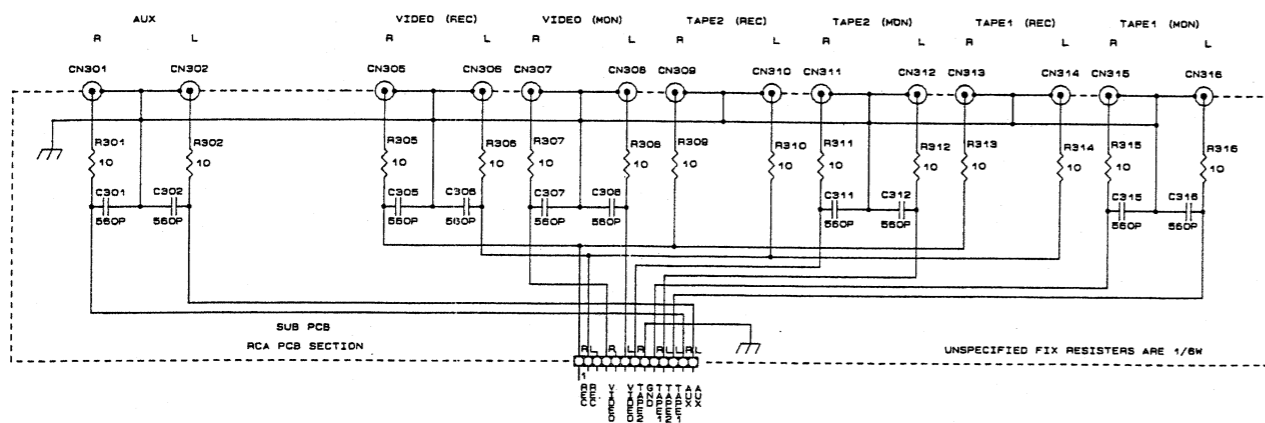

REGULATOR PCB (IA600, IA400)

W, C MODEL

E, V MODEL

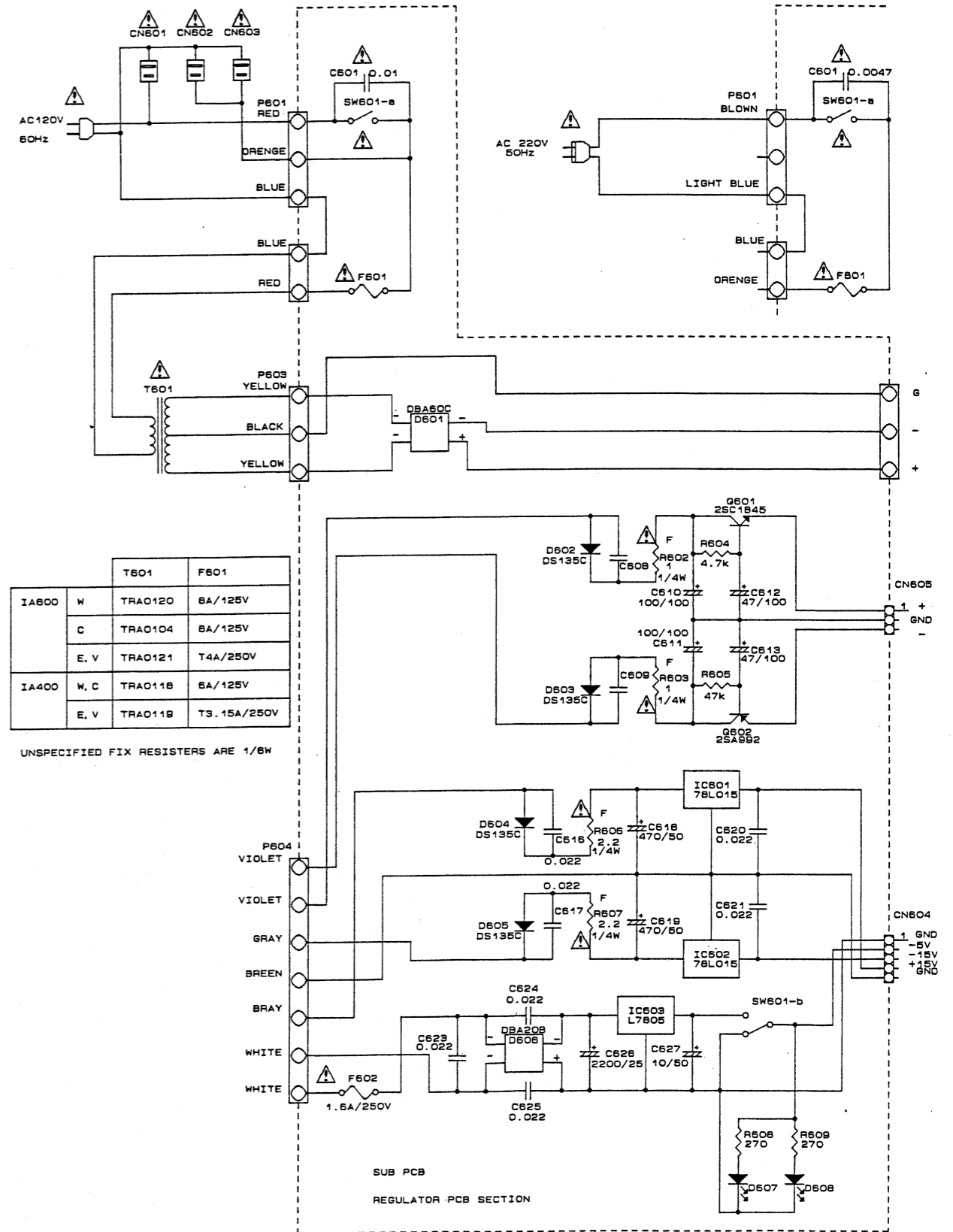

WIRING DIAGRAM

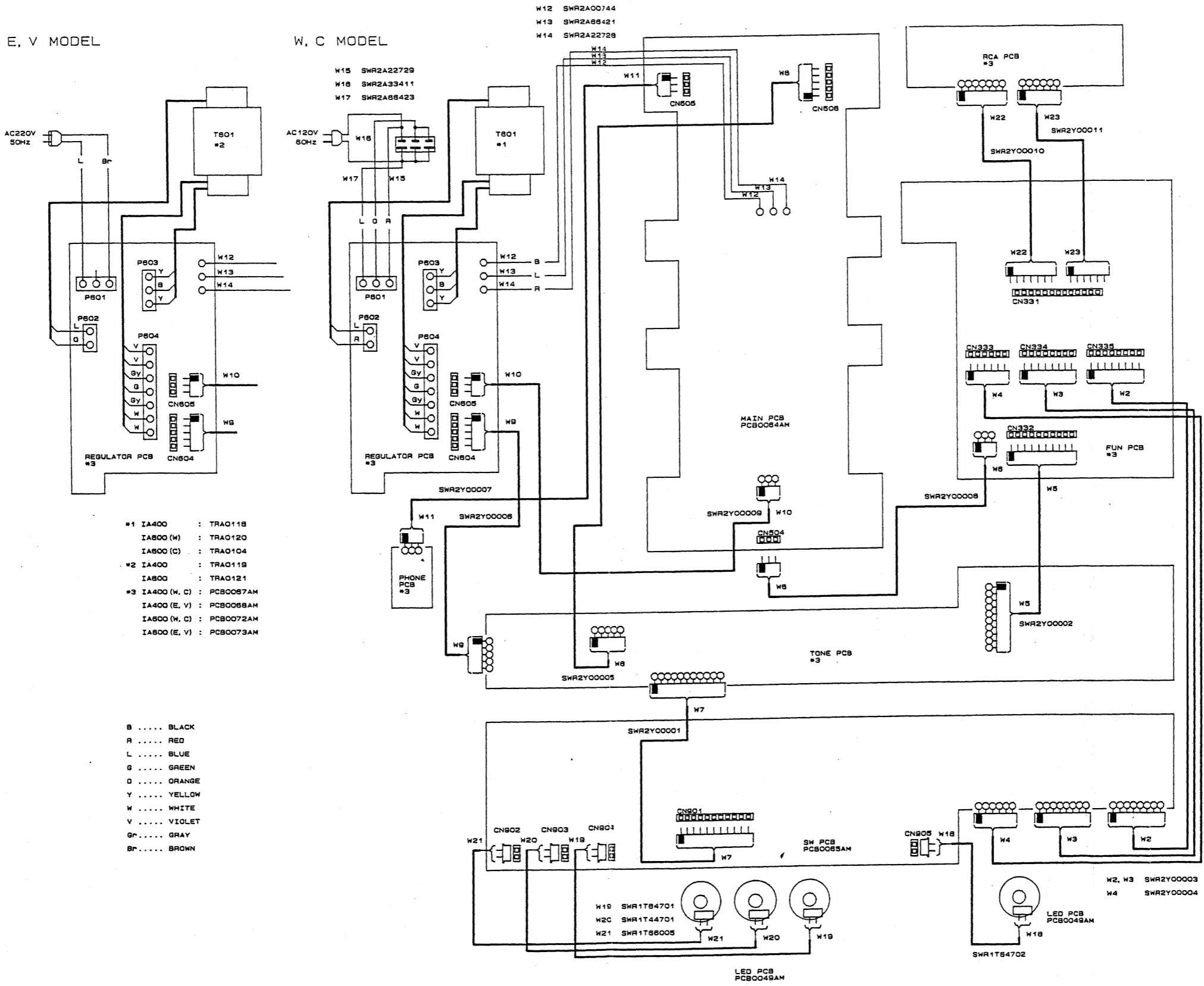

EXPLODED VIEWS

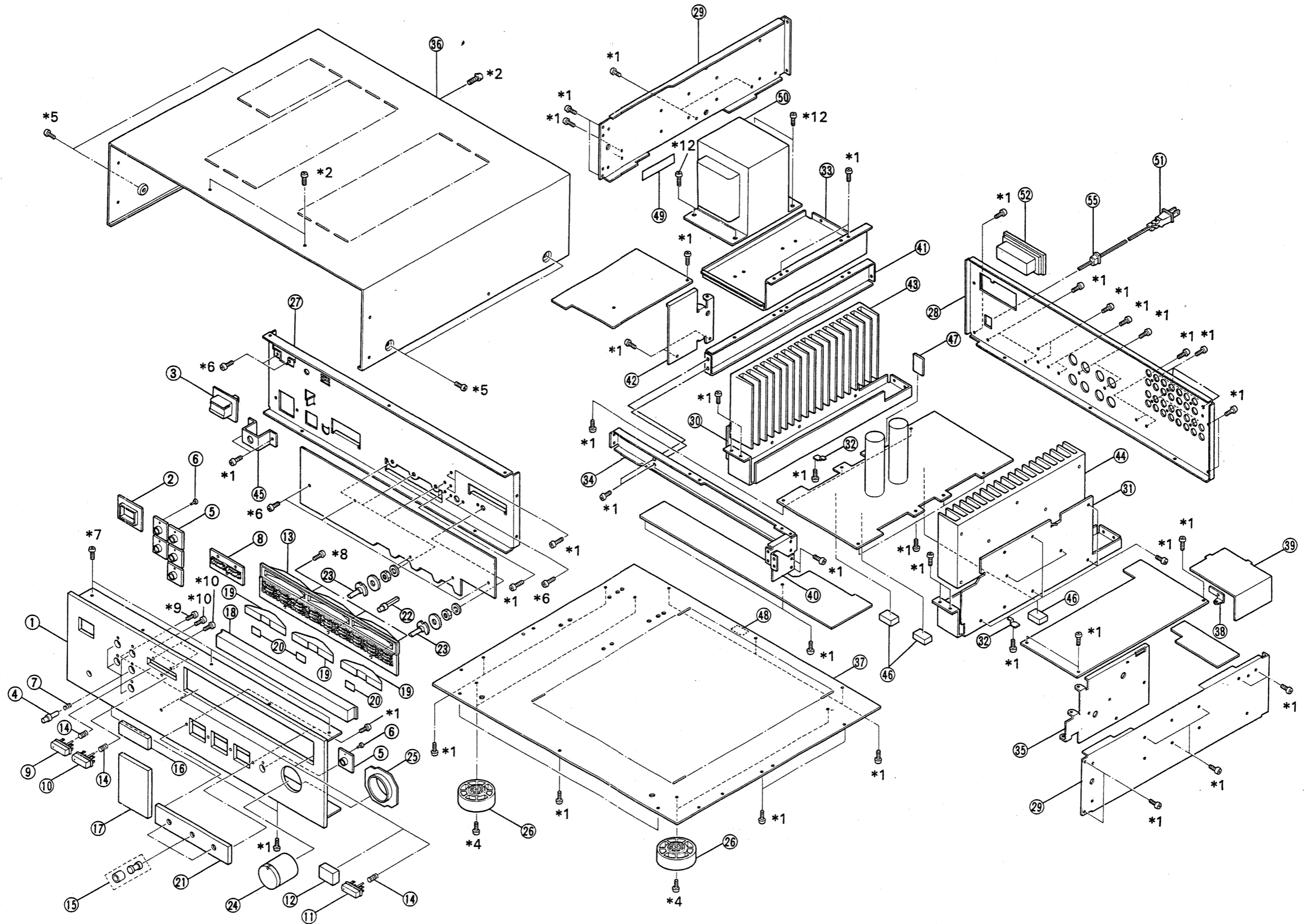

PARTS ORDERING PROCEDURE DO NOT USE THE "REFERENCE" number and "SYMBOL" number. (these are control numbers for the factory only.)
Include in any order: a. Part number, b. Part description, c. Model number. (any of the above lacking from an order may delay shipment of the order.)

REF NO.	SYMBOL NO.	IA600 W C E V W C E V	IA400 W C E V W C E V	DESCRIPTION	PARTS NO.
<< FUNCTION PCB SECTION >>					
		1 1 1 1 1 1 1 1		GND PLATE	PRST04910
IC301.302		2 2 2 2 2 2 2 2		IC LB1245	ICT0412
IC303~314		12 12 12 12 12 12 12 12		IC LC4966	ICT0413
IC315		1 1 1 1 1 1 1 1		IC μ PC4570HA	ICT0312
Q301.302		2 2 2 2 2 2 2 2		TR 2SC3327 (A,B)	TRNC3327
Q303~306		4 4 4 4 4 4 4 4		TR 2SA991 (F,E)	TRNA991
Q307~310		4 4 4 4 4 4 4 4		TR 2SC3327 (A,B)	TRNC3327
Q311		1 1 1 1 1 1 1 1		DTR DTA144EF	TRNZA144EF
Q312		1 1 1 1 1 1 1 1		TR 2SA881 (R,Q)	TRNA881
Q313.314		2 2 2 2 2 2 2 2		DTR DTA144EF	TRNZA144EF
Q315~317		3 3 3 3 3 3 3 3		DTR DTC123EF	TRNZC123EF
D301.302		2 2 2 2 2 2 2 2		DI GMA01	DIOS0023
D305.306		2 2 2 2 2 2 2 2		DI GMA01	DIOS0023
L301.302		2 2 2 2 2 2 2 2		INDUCTOR 180 μ H	CILA18101
C317.318		2 2 2 2 2 2 2 2		C-CAP 560 pF	CAPB56101G
C321~330		10 10 10 10 10 10 10 10		C-CAP 560 pF	CAPB56101G
C331.332		2 2 2 2 2 2 2 2		E-CAP 10 μ F	CAPA10621D
C333.334		2 2 2 2 2 2 2 2		C-CAP 0.0022 μ F	CAPB22202G
C335.336		2 2 2 2 2 2 2 2		E-CAP 2200 μ F	CAPA22805D
C337.338		2 2 2 2 2 2 2 2		M-CAP 0.039 μ F	CAPE39301D
C339.340		2 2 2 2 2 2 2 2		M-CAP 0.01 μ F	CAPC10305D
C341.342		2 2 2 2 2 2 2 2		M-CAP 0.001 μ F	CAPC10203D
C343.344		2 2 2 2 2 2 2 2		E-CAP 1 μ F	CAPA10505D
C345.346		2 2 2 2 2 2 2 2		C-CAP 100 pF	CAPB10108G
C347.348		2 2 2 2 2 2 2 2		E-CAP 1000 pF	CAPA10810D
C349		1 1 1 1 1 1 1 1		E-CAP 47 μ F	CAPA47614D
C352.353		2 2 2 2 2 2 2 2		C-CAP 0.022 μ F	CAPB22304H
C354		1 1 1 1 1 1 1 1		E-CAP 2200 μ F	CAPA22805D
C357.358		- - - - - 2 - 2		C-CAP 0.1 μ F	CAPB10403H
R317.318		2 2 2 2 2 2 2 2		RES 10 OHM 1/4W	RES110001E
R319.320		2 2 2 2 2 2 2 2		RES 560 OHM 1/4W	RES156102E
R321~328		8 8 8 8 8 8 8 8		RES 10 OHM 1/4W	RES110001E
R331.332		2 2 2 2 2 2 2 2		RES 100k OHM 1/6W	RES110406B
R333.334		2 2 2 2 2 2 2 2		RES 100 OHM 1/6W	RES110101B
R335.336		2 2 2 2 2 2 2 2		RES 91k OHM 1/6W	RES191303B
R337~340		4 4 4 4 4 4 4 4		RES 6.8k OHM 1/6W	RES168202B
R341.342		2 2 2 2 2 2 2 2		RES 100 OHM 1/6W	RES110101B
R343.344		2 2 2 2 2 2 2 2		RES 4.7k OHM 1/6W	RES147209B
R345.356		2 2 2 2 2 2 2 2		RES 3.3k OHM 1/6W	RES133203B
R347.348		2 2 2 2 2 2 2 2		RES 560 OHM 1/6W	RES156101B
R349.350		2 2 2 2 2 2 2 2		RES 15 OHM 1/6W	RES115001B
R351.352		2 2 2 2 2 2 2 2		RES 150 OHM 1/6W	RES115101B

REF NO.	SYMBOL NO.	IA600 W C E V W C E V	IA400 W C E V W C E V	DESCRIPTION	PARTS NO.
R353.354		2 2 2 2 2 2 2 2		RES 82k OHM 1/6W	RES182303B
R355.356		2 2 2 2 2 2 2 2		RES 6.8k OHM 1/6W	RES168202B
R357.358		2 2 2 2 2 2 2 2		RES 150 OHM 1/6W	RES115101B
R359.360		2 2 2 2 2 2 2 2		RES 470 OHM 1/6W	RES147103B
R361.362		2 2 2 2 2 2 2 2		RES 4.7k OHM 1/6W	RES147209B
R363.364		2 2 2 2 2 2 2 2		RES 47k OHM 1/6W	RES147302B
R365~370		6 6 6 6 6 6 6 6		RES 100k OHM 1/6W	RES110406B
R371.372		2 2 2 2 2 2 2 2		FP-RES 100 OHM 1/4W	RES010101A
R373		1 1 1 1 1 1 1 1		RES 10k OHM 1/6W	RES110303B
R374		1 1 1 1 1 1 1 1		RES 1k OHM 1/6W	RES110203B
R377		1 1 1 1 1 1 1 1		FP-RES 56 OHM 1/4W	RES056001A
R378		1 1 1 1 1 1 1 1		RES 4.7k OHM 1/6W	RES147209B
R379		1 1 1 1 1 1 1 1		RES 100k OHM 1/6W	RES110406B
R380.381		2 2 2 2 2 2 2 2		RES 4.7k OHM 1/6W	RES147209B
CN304.305		2 2 2 2 2 2 2 2		4P PIN JACK	SKT0219
CN306		1 1 1 1 1 1 1 1		6P PIN JACK	SKT0218
CN331		1 1 1 1 1 1 1 1		CONNECTOR HBRN135-1	SKT0234
CN332		1 1 1 1 1 1 1 1		CONNECTOR CJP3110-0101	SKT0223
CN333		1 1 1 1 1 1 1 1		CONNECTOR CJP3106-0101	SKT0188
CN334.335		2 2 2 2 2 2 2 2		CONNECTOR CJP3108-0101	SKT0222
<< RCA PCB SECTION >>					
CN301		1 1 1 1 - - - -		4P PIN JACK	SKT0219
CN301		- - - - 1 1 1 1		2P PIN JACK	SKT0220
CN302.303		2 2 2 2 2 2 2 2		6P PIN JACK	SKT0218
C301.302		2 2 2 2 2 2 2 2		C-CAP 560 pF	CAPB56101G
C303.304		2 2 2 2 - - - -		C-CAP 560 pF	CAPB56101G
C305~308		4 4 4 4 4 4 4 4		C-CAP 560 pF	CAPB56101G
C311.312		2 2 2 2 2 2 2 2		C-CAP 560 pF	CAPB56101G
C315.316		2 2 2 2 2 2 2 2		C-CAP 560 pF	CAPB56101G
R301.302		2 2 2 2 2 2 2 2		RES 10 OHM 1/4W	RES110003E
R303.304		2 2 2 2 - - - -		RES 10 OHM 1/4W	RES110003E
R305~316		12 12 12 12 12 12 12 12		RES 10 OHM 1/4W	RES110003E
<< PHONE PCB SECTION >>					
CN501		1 1 1 1 1 1 1 1		PHONE JACK	SKT0052
LED PCB ASSEMBLY					
D938~941		1 1 1 1 1 1 1 1		LED PCB	PCB0049AM
		4 4 4 4 4 4 4 4		LED GL3PG43	DIOQ0066

SCREWS, WASHER LIST

REF NO.	DESCRIPTION		PARTS NO.
*1	Binding head screw B	3x8	BIS6K08001
*2	Binding head screw B	3x8	BIS6K08005
*3	Binding head screw B	3x10	BIS6K10001
*4	Binding head screw B	3x12	BIS6K12001
*5	BW head screw B	4x8	BIS7M08012
*6	Binding head machine screw	3x6	BIS6K06012
*7	Countersunk head screw B	3x6	BIS2K06004
*8	Countersunk head machine screw	2.6x6	BIS2J06002
*9	Countersunk head machine screw	3x6	BIS2K06001
*10	Countersunk head machine screw	3x10	BIS2K10000
*11	Brazier head screw B	3x12	BIS7K12003
*12	Brazier head screw S	4x8	BIS7M08015