

ONKYO® SERVICE MANUAL

Integrated Stereo Amplifier MODEL A-8830 A-803



Black and Silver models

SAFETY-RELATED COMPONENT WARNING!!

COMPONENTS IDENTIFIED BY MARK Δ ON THE SCHEMATIC DIAGRAM AND IN THE PARTS LIST ARE CRITICAL FOR RISK OF FIRE AND ELECTRIC SHOCK. REPLACE THESE COMPONENTS WITH ONKYO PARTS WHOSE PARTS NUMBERS APPEAR AS SHOWN IN THIS MANUAL.

MAKE LEAKAGE-CURRENT OR RESISTANCE MEASUREMENTS TO DETERMINE THAT EXPOSED PARTS ARE ACCEPTABLY INSULATED FROM THE SUPPLY CIRCUIT BEFORE RETURNING THE APPLIANCE TO THE CUSTOMER.

TABLE OF CONTENTS

Specifications	2
Precautions	2
Adjustment procedures	3
IC block diagram	4
Chassis exploded view	9
Front panel facilities	11
System connections	11
Printed circuit board parts list	12
Block diagram	15
Printed circuit board view	17
Schematic diagram	19
Parts list of packing	23

ONKYO
AUDIO COMPONENTS

ONKYO® SERVICE MANUAL

Integrated Stereo Amplifier MODEL A-803

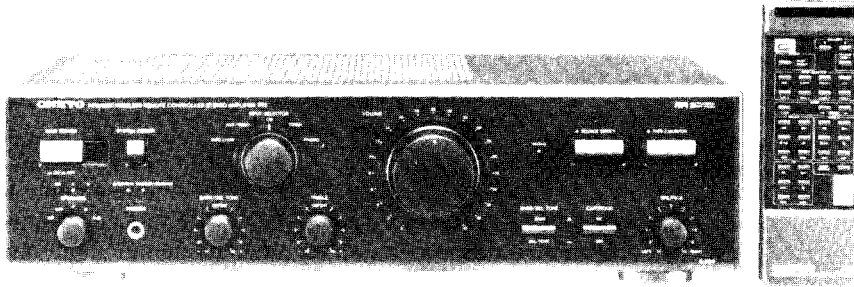

Black and Silver models

UD	120V AC, 60Hz
UP	230V AC, 50Hz
UW	120V/220V AC, 50Hz/60Hz

SAFETY-RELATED COMPONENT WARNING!!

COMPONENTS IDENTIFIED BY MARK Δ ON THE SCHEMATIC DIAGRAM AND IN THE PARTS LIST ARE CRITICAL FOR RISK OF FIRE AND ELECTRIC SHOCK. REPLACE THESE COMPONENTS WITH ONKYO PARTS WHOSE PARTS NUMBERS APPEAR AS SHOWN IN THIS MANUAL.

MAKE LEAKAGE-CURRENT OR RESISTANCE MEASUREMENTS TO DETERMINE THAT EXPOSED PARTS ARE ACCEPTABLY INSULATED FROM THE SUPPLY CIRCUIT BEFORE RETURNING THE APPLIANCE TO THE CUSTOMER.

TABLE OF CONTENTS

Specifications	2
Precautions	2
Adjustment procedures	3
IC block diagram	4
Chassis exploded view	9
Front panel facilities	11
System connections	11
Printed circuit board parts list	12
Block diagram	15
Schematic diagram	17
Parts list of packing	25

ONKYO
AUDIO COMPONENTS

SPECIFICATIONS

Power Output:	60 watts per channel, min RMS, at 8 ohms, both channels driven from 20 Hz to 20 kHz, with no more than 0.06% THD.	
	2 × 100 watts at 4 ohms, 1 kHz(DIN)	
	2 × 70 watts at 8 ohms, 1 kHz(DIN)	
Total Harmonic Distortion	0.06% at rated power	
IM Distortion	0.06% at rated power	
Damping Factor:	40 at 8 ohms	
Frequency and Response:	15–30,000 Hz ±1 dB	
Input Sensitivity/Impedance:	Phono (MM):	2.5 mV/50 kohms
	Phono (MC):	350 μV/220 ohms
	Tuner/CD/AUX, Video:	150 mV/50 kohms
	Source Direct:	150 mV/50 kohms
	Tape/Play:	150 mV/50 kohms
Output Sensitivity/Impedance:	Tape/Rec:	150 mV/3 kohms (phono)
Phono Overload:	135 mV RMS at 1 kHz, 0.1% THD (MM) (REC)	
Bass Control:	±10 dB at 100 Hz	
Treble Control:	±10 dB at 10,000 Hz	
Selective Tone Control:	±15 dB at 50 Hz/±6 dB at 10 kHz	
Signal to Noise Ratio (IHF-A):	Phono (MM):	80 dB (5 mV input)
	Phono (MC):	70 dB (0.5 mV input)
	Source Direct (CD):	102 dB

General

Power Supply:	U.S.A & Canadian models: AC 120V, 60Hz
	European models (except U.K.): AC 230V, 50Hz
	U.K. & Australian models: AC 240V, 50Hz
	Worldwide models: AC 120 and 220V switchable, 50/60Hz

Dimensions (W) × (H) × (D):	455 × 120 × 330 mm
	17-15/16" × 4-3/4" × 13"
Weight:	7.3 kg, 16.1 lbs.

Remote Control Transmitter RC-200S/205S

Transmitter:	Infrared
Signal range:	Approx. 5 meters, 16ft
Power supply:	Two "AA" batteries (1.5 V × 2)
Dimensions (W × H × D):	64 × 18 × 176 mm
	2-1/2" × 11/16" × 6-15/16"
Weight:	130 grams, 4.6 oz. (including batteries)

Specifications and features are subject to change without notice.

PRECAUTIONS

1. Replacing the fuses

For continued protection against risk fire, replace only with same type and same rating fuse.

CIRCUIT NO.	PART NO.	DESCRIPTION
F901	252050	5A ST-6, Primary fuse (120V,120V/220V model)
F901	252075	2.5A-SE-EAK, Primary fuse (230V model)
F902	252075	2.5A-SE-EAK, Primary fuse (230V,120V/220V model)

2. Insulation resistance measurement (Only U.S.A. model)

Connect the insulating-resistance tester between the plug of power supply cable and the terminal GND on the back panel. Specifications; More than 10 MΩ at 500V.

3. Voltage selector (rear panel)

Worldwide models are equipped with a voltage selector to conform with local power supplies. Be sure to set this switch to match the voltage of the power supply in your area before turning the power switch on. Voltage is changed by sliding the groove in the switch with a screwdriver to the right or left. Confirm that the switch has been moved all the way to the right or left before turning the power switch on. Models without a voltage selector can only be used in areas where the power supply is the same as that of the unit.

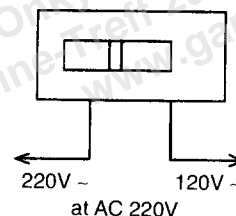
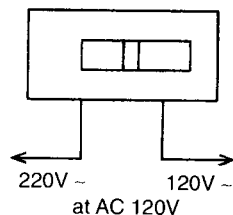

ADJUSTMENT PROCEDURES

Adjustments and Checking the Protection Circuitry

1. Preparations

- 1) Place the unit on the workbench. (There should be about 15 mm of space between the base plate of the unit and the work surface.)
- 2) Set up the unit as follows.
 - (1) No load
 - (2) No signal
 - (3) Volume turned all the way down
 - (4) Speaker switch OFF
 - (5) Power switch OFF

Note) Check the following points before making adjustments

- (1) The power switch should be OFF.
- (2) The interior of the unit should not be warm.

2. Idling current adjustment

- 1) Turn the power switch ON and allow the unit to warm up for about 10 minutes.
 - (1) Adjust R531 (R532) so that the voltage at test point VCT-ID on the NAAF-4169 circuit board is $9.5\text{mV} \pm 3.5\text{mV}$

3. Check of operation of protection circuitry

- 1) Check of operation of protection relay.
 - (1) Confirm that the relay turns ON approximately 5 seconds after the power switch is turned ON.
 - (2) The relay should turn OFF approximately 0.5 seconds after the power switch is turned OFF.
- 2) Check of DC detection
 - (1) Turn the power on with no load.
 - (2) After the speaker relay turns ON, apply DC +1.5V to the CD input terminals. Confirm that the relay turns OFF.
 - (3) Confirm that operation is the same as (2) above when an input of DC -1.5V is applied.

Note) Under no circumstances connect a load or short the speaker terminals when performing the above test.

3) Confirmation of current detection operation

- (1) Signal input from the circuit illustrated below with no load.
- (2) Confirm that the speaker relay does not turn OFF even when a 2 ohm load is connected when a peak value of 35Vp is output.
- (3) Next, confirm that when a 1 ohm load is connected the speaker relay switches OFF and ON a couple of times and then stays OFF.

Note) The period before that relay stays OFF should not last for more than 10 second.

Relay OFF status can be canceled by switching the power OFF.

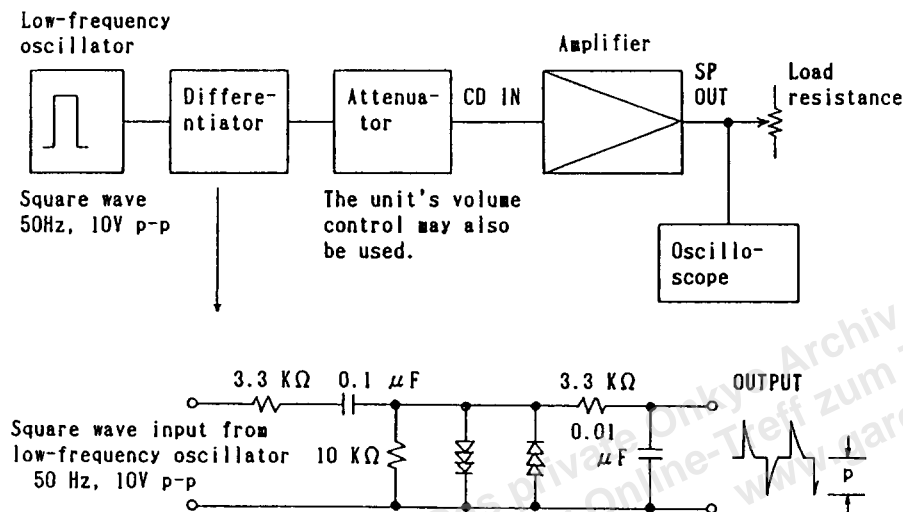

NOTE) Semi-fixed resistors enclosed in parentheses () are for the right channel.

CX20106A (Preamplifier)

1. IN: Input terminal
2. C1: Frequency response and gain setting terminal of head amplifier
3. C2: Connect to the capacitor for detector
4. GND: Ground terminal
5. fo: Center frequency setting terminal of BPF
6. C3: Connect to the capacitor for integrator
7. OUT: Output terminal
8. Vcc: Power supply terminal

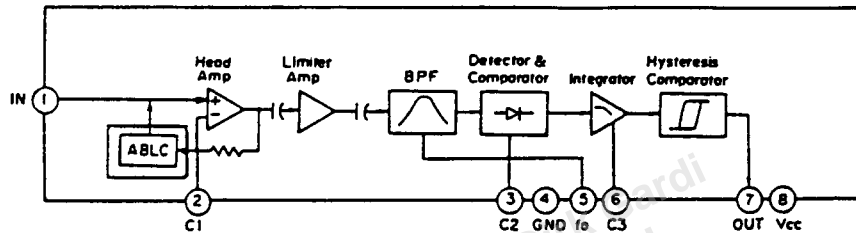

LB1639 (Motor Drive)

LC7822N (Analog Switch)

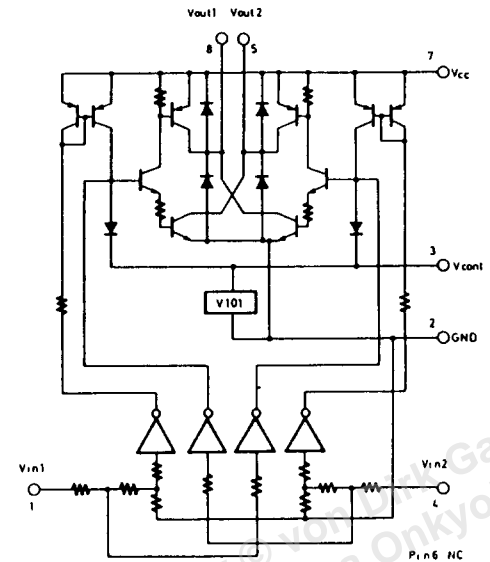
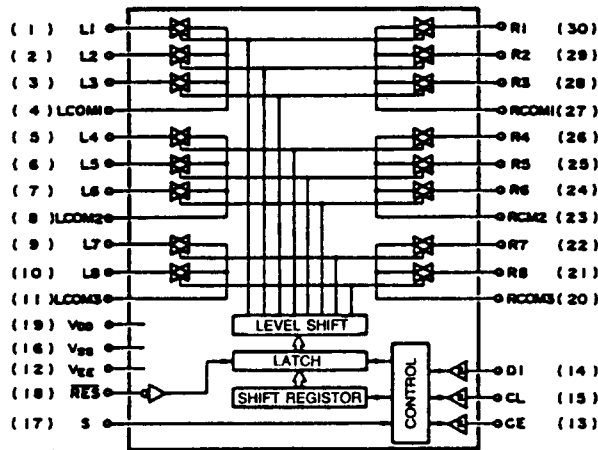

TRUTH TABLE

IN 1	IN 2	OUT 1	OUT 2	MOTOR
H	L	H	L	Normal
L	H	L	H	Reverse
H	H	OFF	OFF	Wait
L	L	OFF	OFF	Wait

CHASSIS-EXPLODED VIEW

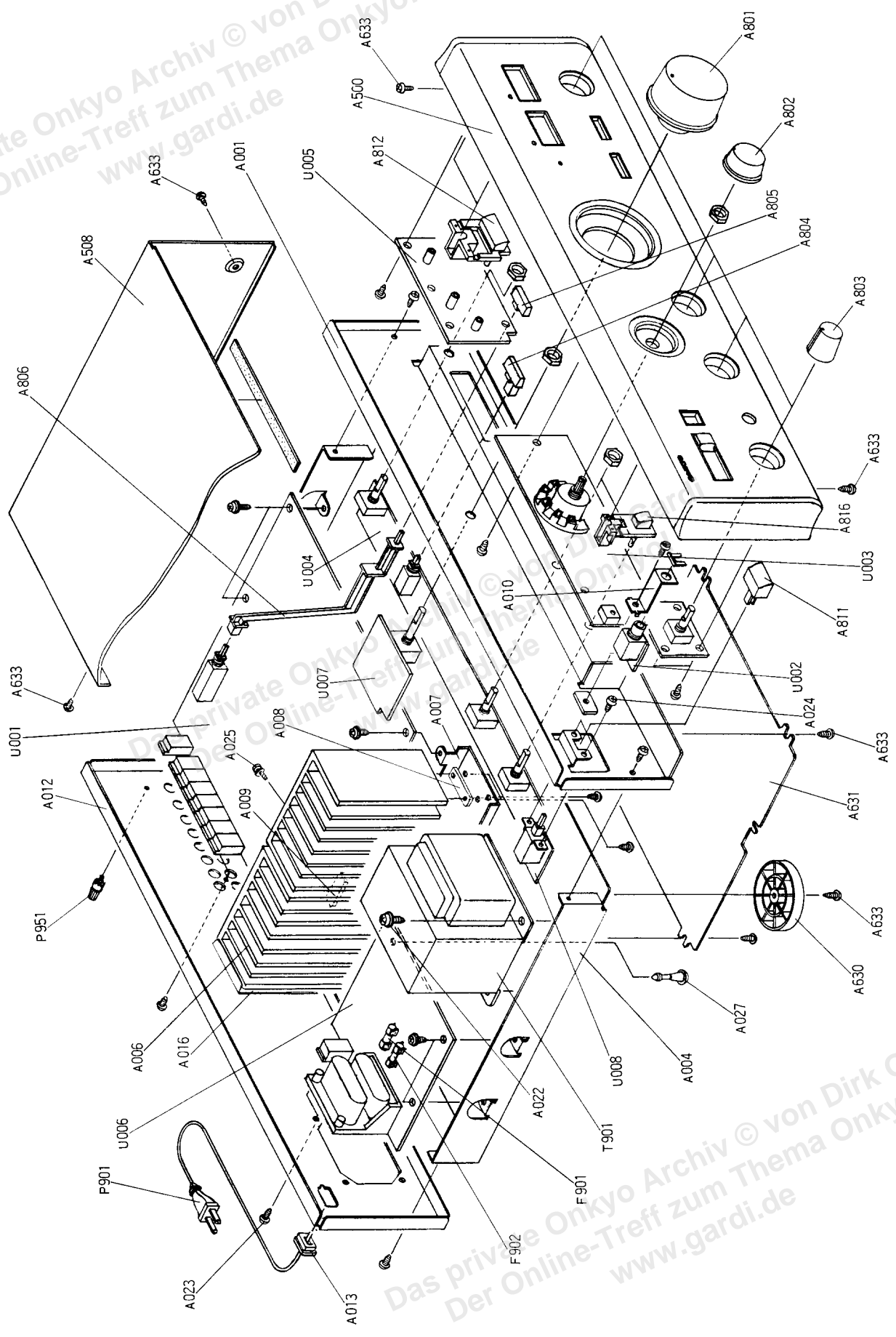

CHASSIS-EXPLODED VIEW PARTS LIST

REF.NO.	PART NO.	DESCRIPTION	REF.NO.	PART NO.	DESCRIPTION	
A001	27110632A	FRONT BRACKET	△ T901	2300648	NPT-1106DG, POWER TRANSFORMER [W]	
A004	27100237	CHASSIS	△ P901	253123	AS-UC-6 #18 or [D]	
A006	27160277B	HEATSINK		253146	AS-UC-6 #18 or	
A007	27130652A	BRACKET (HE)		253161	AS-UC-6 #18, POWER SUPPLY CABLE	
A008	27190840A	HOLDER (HE-L)	△ P901	253149	AS-CEE, POWER SUPPLY CABLE [P,W]	
A009	27190841	HOLDER (HE-S)		P951	25060044	GROUND TERMINAL
A010	27141420	BRACKET (HP)	△ S902	25065287	NSS-2213P, SLIDE SWITCH [W]	
A012	27121424	BACK PLATE [D]	△ F901	252050	5A(ST-6), FUSE [D,W]	
A012	27121425	BACK PLATE [P]	△ F901,F902	252075	2.5A-SE-EAK, FUSE [P,W]	
A012	27121427	BACK PLATE [W]	U001	1A270569-1	NAAF-4169-1, INPUT TERMINAL CIRCUIT PC BOARD ASS'Y [D]	
A013	27300750	BUSHING (CABLE)	U001	1A270569-1A	NAAF-4169-1A, INPUT TERMINAL CIRCUIT PC BOARD ASS'Y [P, W]	
A016	28175183	INSULATING PLATE [D]	U002	1A270570-1	NAETC-4170-1, PHONES CIRCUIT PC BOARD ASS'Y	
A022	830440089	4TTC+8CBC, TAPPING SCREW	U003	1A270571-1	NADG-4171-1, SYSTEM CONTROL CIRCUIT PC BOARD ASS'Y [D]	
A023	833430080	3TTP+8PBC, TAPPING SCREW	U003	1A270571-1A	NADG-4171-1A, SYSTEM CONTROL CIRCUIT PC BOARD ASS'Y [P, W]	
A025	801433	3SMS8WSW+14BBC, SPECIAL SCREW	U004	1A270572-1	NAAF-4172-1, TONE CONTROL CIRCUIT PC BOARD ASS'Y [D]	
A027	27190657	KGLS-18RT, HOLDER	U004	1A270572-1A	NAAF-4172-1A, TONE CONTROL CIRCUIT PC BOARD ASS'Y [P, W]	
A500	1A270121	FRONT PANEL ASS'Y [BLK]	U005	1A270573-1	NASW-4173-1, TAPE-2 AND DIRECT SWITCH CIRCUIT PC BOARD ASS'Y	
(A502)	28135199	NAME PLATE	U006	1A270574-1	NAPS-4174-1, POWER SUPPLY CIRCUIT PC BOARD ASS'Y [D]	
(A504)	28125226	END CAP (L)	U006	1A270574-1A	NAPS-4174-1A, POWER SUPPLY CIRCUIT PC BOARD ASS'Y [P]	
(A505)	28125227	END CAP (R)	U006	1A270574-1B	NAPS-4174-1B, POWER SUPPLY CIRCUIT PC BOARD ASS'Y [W]	
(A511)	27267723	GUIDE (VOL) [BLK]	U007	1A270575-1	NAETC-4175-1, VOLUME CONTROL CIRCUIT PC BOARD ASS'Y	
(A512)	27267725	GUIDE ASS'Y (SEL) [BLK]	U008	1A270577-1	NASW-4177-1, POWER SWITCH CIRCUIT PC BOARD ASS'Y [D]	
(A518)	27267710B	GUIDE (DIR) [BLK]	U008	1A270577-1A	NASW-4177-1A, POWER SWITCH CIRCUIT PC BOARD ASS'Y [P, W]	
(A520)	27267714B	GUIDE (POW) [BLK]	U009	1A270578-1	NAETC-4178-1, AC SOCKET CIRCUIT PC BOARD ASS'Y	
(A820)	28191593	CLEAR PLATE				
(A821)	28198742	PACKET				
A500	1A271121	FRONT PANEL ASS'Y [SIL]				
(A511)	27267724	GUIDE (VOL) [SIL]				
(A512)	27267726	GUIDE ASS'Y (SEL) [SIL]				
(A518)	27267711B	GUIDE (DIR) [SIL]				
(A520)	27267715B	GUIDE (POW) [SIL]				
A508	28184484A	TOP COVER				
A630	27175254	BOTTOM LEG ASS'Y				
A631	27170279	BOTTOM BOARD				
A633	834430088	3TTS+8BBC, TAPPING SCREW				
A801	28324317	KNOB (VOL) [BLK]				
A801	28324318	KNOB (VOL) [SIL]				
A802	28324315	KNOB (SEL) [BLK]				
A802	28324316	KNOB (SEL) [SIL]				
A803	28324252-1	KNOB (TON) [BLK]				
A803	28324252-2	KNOB (TON) [SIL]				
A804	28324323A	KNOB (ST) [BLK]				
A804	28324324A	KNOB (ST) [SIL]				
A805	28324251	KNOB (SOR) [BLK]				
A805	28324251-1	KNOB (SOR) [SIL]				
A806	27273138A	JOINT (M)				
A811	28324140	KNOB (POW) [BLK]				
A811	28324184	KNOB (POW) [SIL]				
A812	28324319	KNOB ASS'Y (DIR) [BLK]				
A812	28324320	KNOB ASS'Y (DIR) [SIL]				
A816	28324321	KNOB ASS'Y (S-POW) [BLK]				
A816	28324322	KNOB ASS'Y (S-POW) [SIL]				
Q521,Q522	2201703 or 2201704 or 2201706	2SC3855-O or 2SC3855-Y or 2SC3855-P, TRANSISTOR				
Q523,Q524	2201693 or 2201694 or 2201696	2SA1491-O or 2SA1491-Y or 2SA1491-P, TRANSISTOR				
△ T901	2300646	NPT-1106D, POWER TRANSFORMER [D]				
△ T901	2300647	NPT-1106P, POWER TRANSFORMER [P]				

NOTE [D]: ONLY 120V MODEL
[P]: ONLY 230V MODEL
[W]: ONLY 120V/220V MODEL
[BLK]: ONLY BLACK MODEL
[SIL]: ONLY SILVER MODEL

NOTE:
THE COMPONENTS IDENTIFIED BY MARK △ ARE CRITICAL FOR RISK OF FIRE AND ELECTRIC SHOCK. REPLACE ONLY WITH PART NUMBER SPECIFIED.

PRINTED CIRCUIT BOARD PARTS LIST

INPUT TERMINAL CIRCUIT PC BOARD (NAAF-4169-1, NAAF-4169-1A)

CIRCUIT NO.	PART NO.	DESCRIPTION
ICs		
Q105	22240191	NJM4565D-D
Q201	22240270	LC7822N
Q202	22240025	LC4966
Transistors		
Q101-Q104	2211782 or 2211783	2SA991-F or 2SA991-E
Q203	221282	DTC144ES
Q204	2212600	DTA124ES
Q205	2213290	DTC114ES
Q501,Q503	2213677 or 2213678	2SC3067-G or 2SC3067-H
Q505-Q508	2211455	2SA1015-GR
Q509,Q510	2211732 or 2211733	2SC1845-F or 2SC1845-E
Q511,Q512	2211255	2SC1815-GR
Q513,Q514	2211353 or 2211354	2SA949-O or 2SA949-Y
Q515,Q516	2211633 or 2211634	2SC2229-O or 2SC2229-Y
Q517,Q518	2212653 or 2212654	2SC3421-O or 2SC3421-Y
Q519,Q520	2212643 or 2212644	2SA1358-O or 2SA1358-Y
Q525,Q526	2211732 or 2211733	2SC1845-F or 2SC1845-E
Q528,Q529	2211792 or 2211793	2SA992-F or 2SA992-E
Q530,Q531	2211183	2SC1740-R
Q601-Q603	2213650	DTD113ZS
Q604	2213510	DTA114ES
Q605	2213290	DTC114ES
Diodes		
D101-D104	223163	1SS133
D501-D504		
D601-D603		
D551	224450512	MTZ5.1B, Zener
D911	22380038	RBV602
D912,D913	224451503	MTZ15C
Coils		
L101,L102	231133	NCH-1188 [P,W]
L501,L502	231176	S-1.3C
Capacitors		
C101,C102	373301014	100 pF, 125V, Styrene (PP) [P,W]
C103,C104	374722224	2200 pF, 50V, Film (TF) [P,W]
C105,C106	393180477	4.7 μ F, 50V, Elect.
C107,C108	373302214	220 pF, 125V, Styrene (PP)
C111,C112	374728224	8200 pF, 50V, Film (TF)
C113,C114	354724719	470 μ F, 6.3V, Elect.
C115,C116	371121134	0.011 μ F, 50V, Mylar
C117,C118	371123034	0.03 μ F, 50V, Mylar
C119,C120	393180477	4.7 μ F, 50V, Elect.
C121,C122	374721224	1200 pF, 50V, Film (TF)
C132,C133	354741019	100 μ F, 16V, Elect.
C261-C263	354780339	3.3 μ F, 50V, Elect.
C501,C502	393180477	4.7 μ F, 50V, Elect.
C503,C504	373301014	100 pF, 125V, Styrene (PP)
C507,C508	374721024	1000 pF, 50V, Film (TF)
C509,C510	354722219	220 μ F, 6.3V, Elect.

CIRCUIT NO.	PART NO.	DESCRIPTION
C511,C512	354780339	3.3 μ F, 50V, Elect.
C517-C520	374722234	0.022 μ F, 50V, Film (TF)
C525,C526	374724734	0.047 μ F, 50V, Film (TF)
C537,C538		
C529-C532	354781019	100 μ F, 50V, Elect.
C541-C544	374721024	1000 pF, 50V, Film (TF) [P,W]
C554	354780479	4.7 μ F, 50V, Elect.
C555	354722219	220 μ F, 6.3V, Elect.
C914,C915	3504206	10000 μ F, 50V, Elect.
C916,C917	354761019	100 μ F, 35V, Elect.
C918,C919	354742219	220 μ F, 16V, Elect.
Resistors		
R527,R528	442522704	27 Ω , 1/2W, Metal oxide film
R529,R530	442529104	91 Ω , 1/2W, Metal oxide film
R531,R532	5210062 or 5210216	N06HR4.7KBD or N06HR5KBD, Semi-fixed
R535,R536	442522714	270 Ω , 1/2W, Metal oxide film
R537,R538	441720104	1 Ω , 2W, Metal oxide film
R539-R542	4000080	0.47 Ω , 5W, Metal plate
R543-R546	442520224	2.2 Ω , 1/2W, Metal oxide film
R553-R556		
R547,R548	442520824	8.2 Ω , 1/2W, Metal oxide film
R549,R550	442520564	5.6 Ω , 1/2W, Metal oxide film
R601,R602	441627514	750 Ω , 1W, Metal oxide film
R603	442522724	2.7 k Ω , 1/2W, Metal oxide film
R911,R913	441623914	390 Ω , 1W, Metal oxide film
R912,R914	441624314	430 Ω , 1W, Metal oxide film
Switch		
S101	25035631	NPS-142-L587
Relaies		
RL601,RL602	25065339	NRL-2P5A-DC24V-46
RL603	25065396	NRL-2P1.25A-DC24-067
Jumper sockets		
JL201a,JL501a	25050267	NSCT-3P95
JL301a	25050273	NSCT-9P101
Terminals		
P101	25045333	NPJ-2PDBL185
P201	25045300	NPJ-6PDBL159
P202,P203	25045303	NPJ-4PDBL162
P501	25060125	NTM-8PDMN058
Bracket		
	27141059	Ground

PHONES CIRCUIT PC BOARD (NAETC-4170-1)

CIRCUIT NO.	PART NO.	DESCRIPTION
Resistors		
R571,R572	441623914	390 Ω , 1W, Metal oxide film
Stereo jack		
P571	25045255	VKB26-5009
Heatsink		
	27160166	

SYSTEM CONTROL CIRCUIT PC BOARD (NADG-4171-1, NADG-4171-1A)

CIRCUIT NO.	PART NO.	DESCRIPTION
Photo receiving unit		
U751	24130003	GP1U50XS

CIRCUIT NO. PART NO. DESCRIPTION **TAPE-2 AND DIRECT SWITCH CIRCUIT PC BOARD (NASW-4173-1)**

CIRCUIT NO.	PART NO.	DESCRIPTION
ICs		
Q351	22240322	LB1639
Q701	22240431	LC65204A-4605
Q751,Q752	22240376	MPD17103CX-528
Transistors		
Q702	2211455 or 2213074	2SA1015-GR or 2SA933-R
Q703	2213284	2SC1740S-R
Q704~Q706	2213290	DTC114ES
Q708		
Diodes		
D701~D708	223163	1SS133
D751~D764		
D709	224450562	MTZ5.6B, Zener
D712~D722	225142DX2	SEL2913K-DX2, LED
Osc.element		
X701	3010150	CST4.00MGW
X751,X752	3010154	CST8.00MT
Capacitors		
C352,C703	354741009	10 μ F, 16V, Elect.
C752		
C701	3000051	0.047 F, 5.5V, Super
C704	354780109	1 μ F, 50V, Elect.
C753	354780339	3.3 μ F, 50V, Elect.
Resistors		
R701	49163103404	10 K Ω *4, Network
Switches		
S701	25030345	NRS-1112-15SRM
S702	25030346	NRSF-115-25SRB
S705	25035548	NPS-111-S510
Holders		
	27190836	(LED-5)
	27190811	(LED)

CIRCUIT NO.	PART NO.	DESCRIPTION
Transistor		
Q707	2213290	DTC114ES
Diodes		
D710,D711	22514DX2	SEL2913K-DX2, LED
D720		
Switches		
S703,S704	25035548	NPS-111-S510
Holder		
	27190811	(LED)

POWER SUPPLY CIRCUIT PC BOARD (NAPS-4174-1, NAPS-4174-1A, NAPS-4174-1B)

CIRCUIT NO.	PART NO.	DESCRIPTION
ICs		
Q801	22240345	CX20106A
Q804	222780053	78L05
Transistors		
Q753	221282	DTC144ES [D]
Q802	2213290	DTC114ES
Q803	2213510	DTA114ES
Q901	2213650	DTD113ZS
Q931	2201754 or 2201755	2SD1913-R or 2SD1913-S
Diode		
D801,D803	223163	1SS133
D804,D901		
D931~D934	22380032	1SR139-100
D936,D937		
D935	224450623	MTZ6.2C, Zener
D938	224450512	MTZ5.1B
Capacitors		
C802	354780229	2.2 μ F, 50V, Elect.
C803	354780109	1 μ F, 50V, Elect.
C804	354780339	3.3 μ F, 50V, Elect.
C806	354721019	100 μ F, 6.3V, Elect.
C808	354741009	10 μ F, 16V, Elect.
C902	3500065A	0.01 μ F, AC400V/125V, Film (IS)
C903	374721034	0.01 μ F, 50V, Film (TF)
C931	354742229	2200 μ F, 16V, Elect.
C932,C934	354741019	100 μ F, 16V, Elect.
C935	354721019	100 μ F, 6.3V, Elect.
C936	354742209	22 μ F, 16V, Elect.
C937	374721034	0.01 μ F, 50V, Film (TF)
Resistors		
R931	441622204	22 Ω , 1W, Metal oxide film
R932,R935	442521024	1 K Ω , 1/2W, Metal oxide film
R933	442524714	470 Ω , 1/2W, Metal oxide film
R934	442521224	1.2 K Ω , 1/2W, Metal oxide film
R936	442520224	2.2 Ω , 1/2W, Metal oxide film
R937	442525604	56 Ω , 1/2W, Metal oxide film [D]
R937	442522704	27 Ω , 1/2W, Metal oxide film [P,W]
Mini jack		
P801	25045293	HSJ-1003-01-012
P802	25045172	HSJ-1003-01-020
Relay		
RL901	25065269	NRL-1P5A-DC12V-36ZA [D]

TONE CONTROL CIRCUIT PC BOARD (NAAF-4172-1, NAAF-4172-1A)

CIRCUIT NO.	PART NO.	DESCRIPTION
ICs		
Q301,Q321	22240050	MPC4570C
Capacitors		
C301,C302	354780109	1 μ F, 50V, Elect.
C325,C326		
C305,C306	354780229	2.2 μ F, 50V, Elect.
C323,C324		
C321,C322	374728224	8200 pF, 50V, Film (TF)
C327,C328	374723934	0.039 μ F, 50V, Film (TF)
C331,C332	374722234	0.022 μ F, 50V, Film (TF)
C391,C392	354780339	3.3 μ F, 50V, Elect.
Resistors		
R315	5104292A	N11RGLC250KWT25Z, Variable
R321(R322)	5104291A	N14RLC100KWT25Z, Variable
R335(R336)		
Switch		
S321	25035480	NPS-142-L442

CIRCUIT NO.	PART NO.	DESCRIPTION
RL901	25065248	NRL-1P15A-DC12-29 [P,W]

Jumper sockets

JL701a	25050272	NSCT-8P100
JL702a	25050273	NSCT-9P101
JL721a	25050268	NSCT-4P96
JL722a	25050271	NSCT-7P99

Socket

⚠ P902	25050551	NSCT-6P362 [P,W]
--------	----------	------------------

Fuse holder

⚠ F901a	250113	SN5051 [D,W]
⚠ F901a	25050065	YSH403T [P]
⚠ F902a	25050065	YSH403T [P,W]

Fuse label

⚠ F901b	29360462	5A/125V [D,W]
⚠ F901b	29360405	T2.5A/250V [P]
⚠ F901c	29360462-1	Label [D]

VOLUME CONTROL CIRCUIT PC BOARD (NAETC-4175-1)

CIRCUIT NO.	PART NO.	DESCRIPTION
-------------	----------	-------------

Transistors

Q353,Q354	2212286	or 2SC2878-B or
	2212285	2SC2878-A

Capacitors

C355,C356	354780109	1 μ F, 50V, Elect.
-----------	-----------	------------------------

Resistors

R351(R352)	5104234	N16RGM50KA30F, Variable
------------	---------	-------------------------

Jumper socket

JL704	25050281	NSCT-4P109
-------	----------	------------

POWER SWITCH CIRCUIT PC BOARD (NASW-4177-1, NASW-4177-1A)

CIRCUIT NO.	PART NO.	DESCRIPTION
-------------	----------	-------------

Capacitor

⚠ C901	3500065A	0.01 μ F, AC400V/125V, Film (IS)
--------	----------	--------------------------------------

Switch

⚠ S901	25035550	NPS-111-L512P
--------	----------	---------------

AC SOCKET CIRCUIT PC BOARD (NAETC-4178-1)

CIRCUIT NO.	PART NO.	DESCRIPTION
-------------	----------	-------------

Socket

⚠ P903	25050388	NSCT-6P215, AC Socket
--------	----------	-----------------------

NOTE: [D]: Only 120V models
[P]: Only 230V models
[W]: Only 120V/220V models

NOTE:
THE COMPONENTS IDENTIFIED BY MARK ⚠ ARE CRITICAL FOR RISK OF FIRE AND ELECTRIC SHOCK. REPLACE ONLY WITH PART NUMBER SPECIFIED.

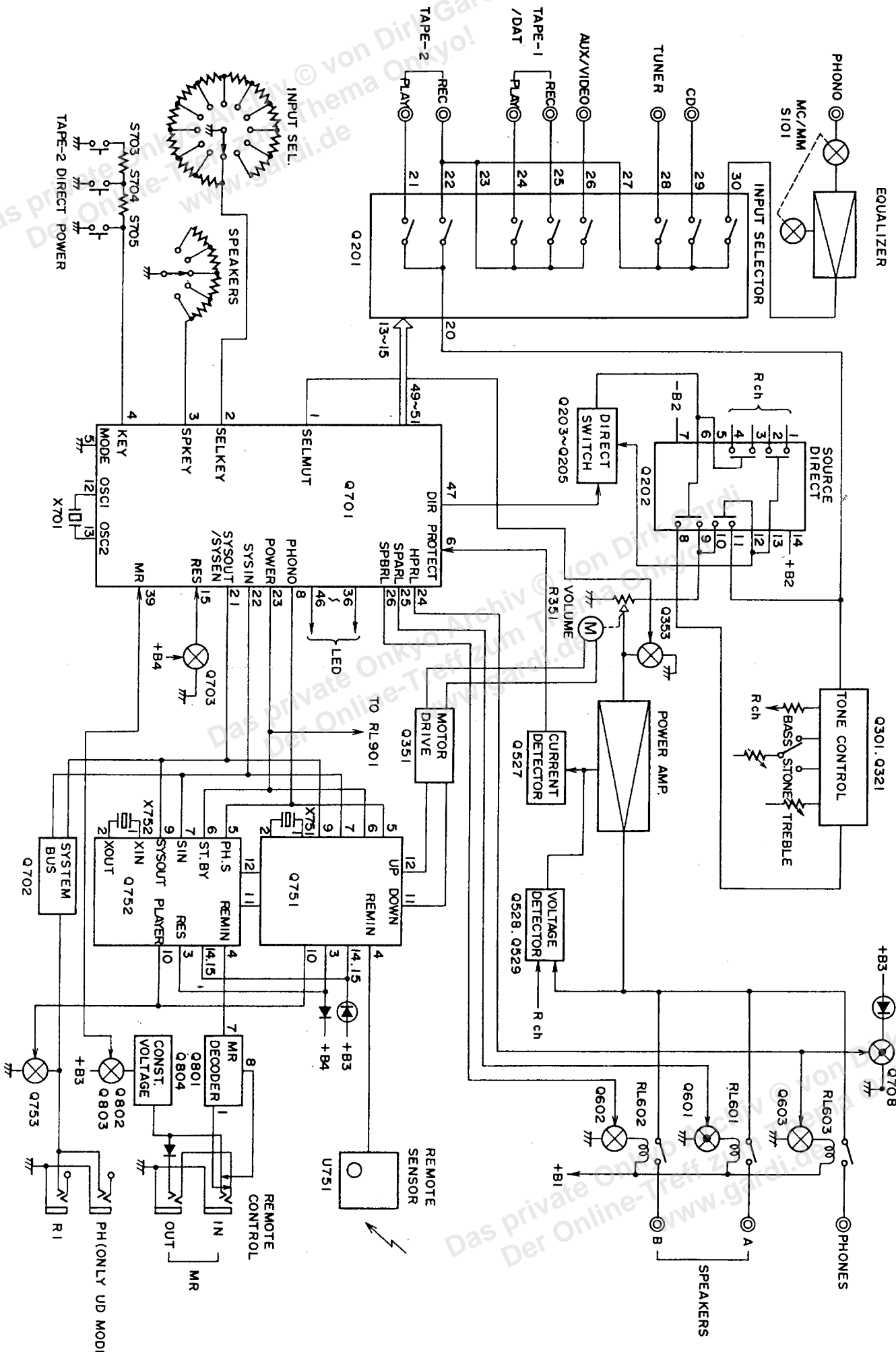

A B C D E F G

SCHEMATIC DIAGRAM

ODEL A-803 (120V)

NOTE:

- THE COMPONENTS IDENTIFIED BY MASK Δ ARE CRITICAL FOR SAFETY.
- REPLACE ONLY WITH PART NUMBER SPECIFIED.
- VOLTAGE MEASURED WITH VOLTMETER ON 15 DC VOLTAGE (NO INPUT SIGNAL).
- RESISTOR VALUES ARE EQUIVALENT TO 25C1815-OR UNLESS OTHERWISE NOTED.
- ALL MPN TRANSISTORS ARE EQUIVALENT TO 25C1815-OR UNLESS OTHERWISE NOTED.
- ALL DIODES ARE EQUIVALENT TO 1S5133 UNLESS OTHERWISE NOTED.
- ELECTROLYTIC CAPACITORS (E) ARE IN μF/WV.
- CAPACITORS ARE IN P/F/50WV UNLESS OTHERWISE NOTED.
- ALL RESISTORS ARE IN OHMS 1/4 WATTS UNLESS OTHERWISE NOTED.
- THE THICK LINES IN PC BOARD ARE THE PRINTING SIDE OF THE PARTS.
- CIRCUIT IS SUBJECT TO CHANGE FOR IMPROVEMENT.

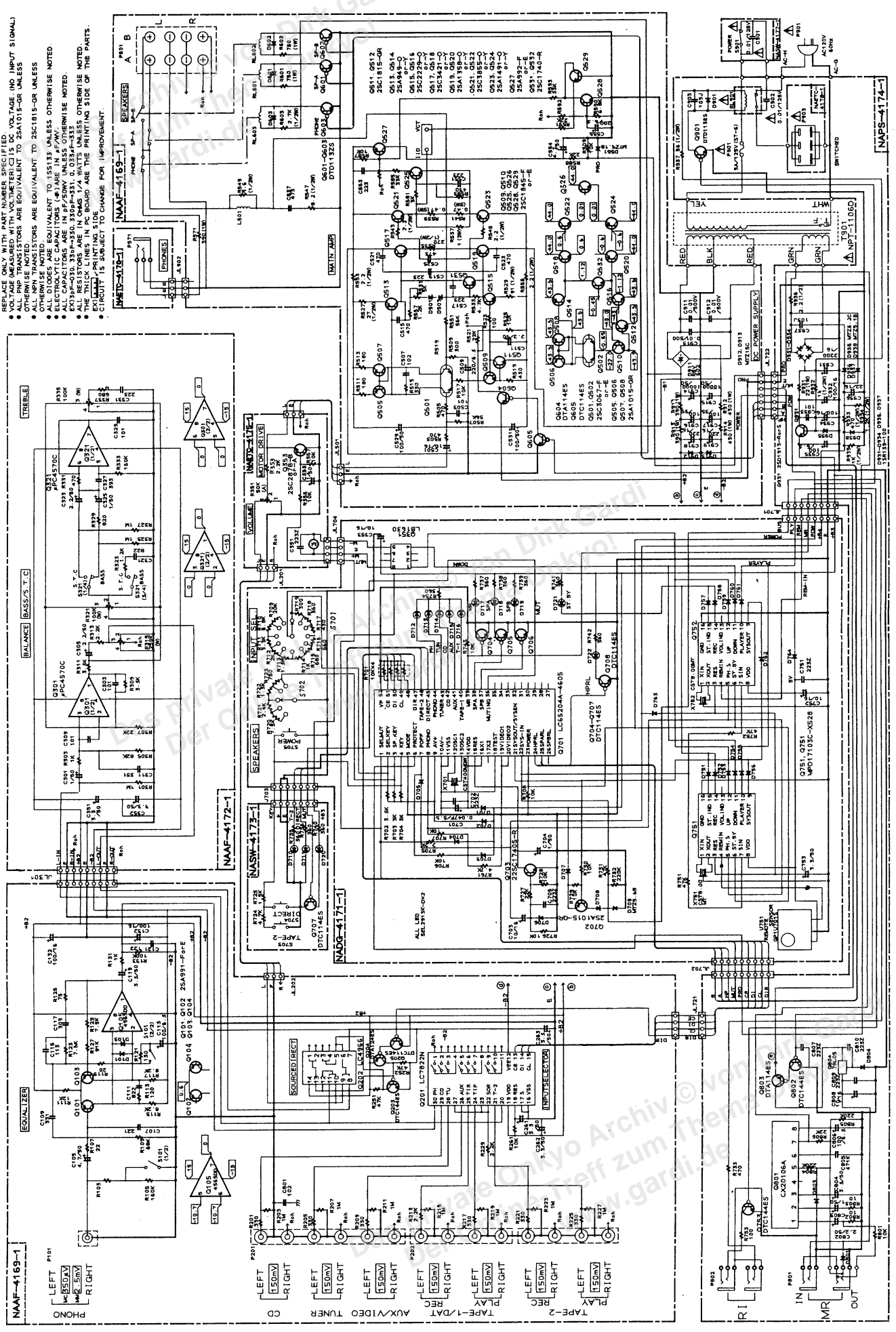

PART LIST OF PACKING

REF.NO.	PART NO.	DESCRIPTION
A851	29052181	MASTER CARTON BOX [BLK]
A851	29052181-3	MASTER CARTON BOX [SIL]
A852	29091470	PAD, LEFT
A853	29091471	PAD, RIGHT
A855	29095378	PROTECTION SEET
A856	29100105	620 × 550mm, POLY-VINYL BAG
A857	282301	SEALING HOOK
A858	29110071	W=50 mm, DAMPLON TAPE
A874	261504	W=30 mm, PAPER TAPE
	29360778	LABEL (FLASH) [N]
ACCESSARY BAG ASS'Y		
A901	29341612	INSTRUCTION MANUAL [D]
	29341614	INSTRUCTION MANUAL [P,W]
	29365019A	WARRANTY CARD [N]
	29365024A	WARRANTY CARD [F]
	29100107	POLY-VINYL BAG (WARRANTY) [F]
	29358002J	SERVICE STATION LIST [N]
A902	29100097	250 × 350, POLY-VINYL BAG
A904	2010200	3.5 MINI CABLE
A906	24140200	RC-200S, REMOTE CONTROL UNIT [D]
A906	24140205	RC-205S, REMOTE CONTROL UNIT [P,W]
A907	3010054	UM-3, TOW BATTERIES
	25055018	CV-K-1, CONVERSION PLUG [W]

NOTE: [D]: ONLY 120V MODEL
[P]: ONLY 230V MODEL
[W]: ONLY 120V/220V MODEL
[N]: ONLY U.S.A. MODEL
[F]: ONLY FRENCH MODEL
[BLK]: ONLY BLACK MODEL
[SIL]: ONLY SILVER MODEL