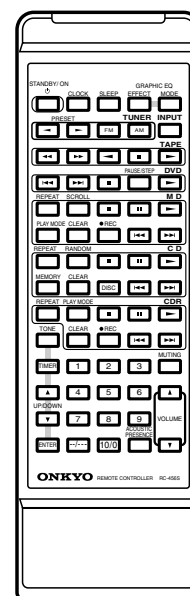
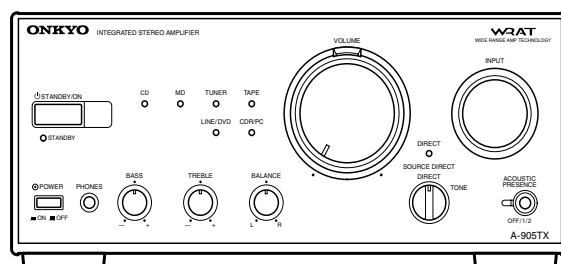

**ONKYO® SERVICE MANUAL****INTEGRATED STEREO AMPLIFIER****A-905TX**

UDT	120V AC, 60Hz
UPT	230-240V AC, 50Hz

**SAFETY-RELATED COMPONENT WARNING!!**

COMPONENTS IDENTIFIED BY MARK  $\triangle$  ON THE SCHEMATIC DIAGRAM AND IN THE PARTS LIST ARE CRITICAL FOR RISK OF FIRE AND ELECTRIC SHOCK. REPLACE THESE COMPONENTS WITH ONKYO PARTS WHOSE PART NUMBERS APPEAR AS SHOWN IN THIS MANUAL.

MAKE LEAKAGE-CURRENT OR RESISTANCE MEASUREMENTS TO DETERMINE THAT EXPOSED PARTS ARE ACCEPTABLY INSULATED FROM THE SUPPLY CIRCUIT BEFORE RETURNING THE APPLIANCE TO THE CUSTOMER.

## SPECIFICATIONS

### Power output

**22 watts per channel, min RMS,  
at 4 ohms, both channels driven  
1 kHz, with no more than 0.5% THD**

**15 watts per channel, min RMS,  
at 8 ohms, both channels driven  
1 kHz, with no more than 0.2% THD**

2 × 20 watts at 4 ohms, 1 kHz (DIN)

2 × 14 watts at 8 ohms, 1 kHz (DIN)

2 × 32 watts at 4 ohms, 1 kHz (EIAJ)

### Total harmonic distortion

0.2% at rated power

### IM distortion

0.2% at rated power

### Damping factor

30 at 8 ohms

### Frequency and response

15 to 30,000 Hz ± 1 dB

### Input sensitivity/impedance

TUNER/LINE/DVD/CD: 200 mV/50 kohms

TAPE PLAY: 200 mV/50 kohms

MD PLAY: 200 mV/50 kohms

CDR/PC PLAY: 200 mV/2.2 kohms

### Output sensitivity/impedance

TAPE REC: 200 mV/2.2 kohms

MD REC: 200 mV/2.2 kohms

CDR/PC REC: 200 mV/2.2 kohms

### Bass control

± 8 dB at 50 Hz

### Treble control

± 8 dB at 10,000 Hz

### Acoustic Presence

1: +3 dB at 20.5 Hz, +3 dB at 82 Hz

2: +3 dB at 20.5 Hz, +6 dB at 82 Hz

### Signal to noise ratio (IHF-A)

LINE/DVD/CD/MD/CDR/PC: 100 dB

### Muting

-50 dB

### Power supply

AC 120 V, 60 Hz

AC 230-240 V, 50 Hz

### Power consumption

(AC 120 V, 60 Hz) : 63 W

(AC 230-240 V, 50 Hz) : 58 W

### Dimensions (W × H × D)

205 × 91 × 302 mm

8-1/16" × 3-9/16" × 11-7/8"

### Weight

3.4 kg, 7.5 lbs

Specifications and external appearance are subject to change without notice as a result of product improvement.

## SERVICE PROCEDURES

### Replacing the fuses

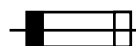
 This symbol located near the fuse indicates that the fuse used is show operating type, For continued protection against fire hazard, replace with same type fuse , For fuse rating, refer to the marking adjust to the symbol.

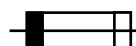
 Ce symbole indique que le fusible utilise est e lent. Pour une protection permanente, n'utiliser que des fusibles de meme type. Ce dernier est indique la qu le present symbol est appose.

REF.NO.	PART NO.	DESCRIPTION
F901	252158	△ 1.6A-UL/T-237, Fuse <DT>
	252069	△ 0.8A-SE-EAK, Fuse <PT>
F902-F904	252075	△ 2.5A-SE-EAK, Fuse <PT>

#### NOTE:

<DT> : Asian model only for 120V

<PT> : Asian model only for 230V

# CHASSIS EXPLODED VIEW

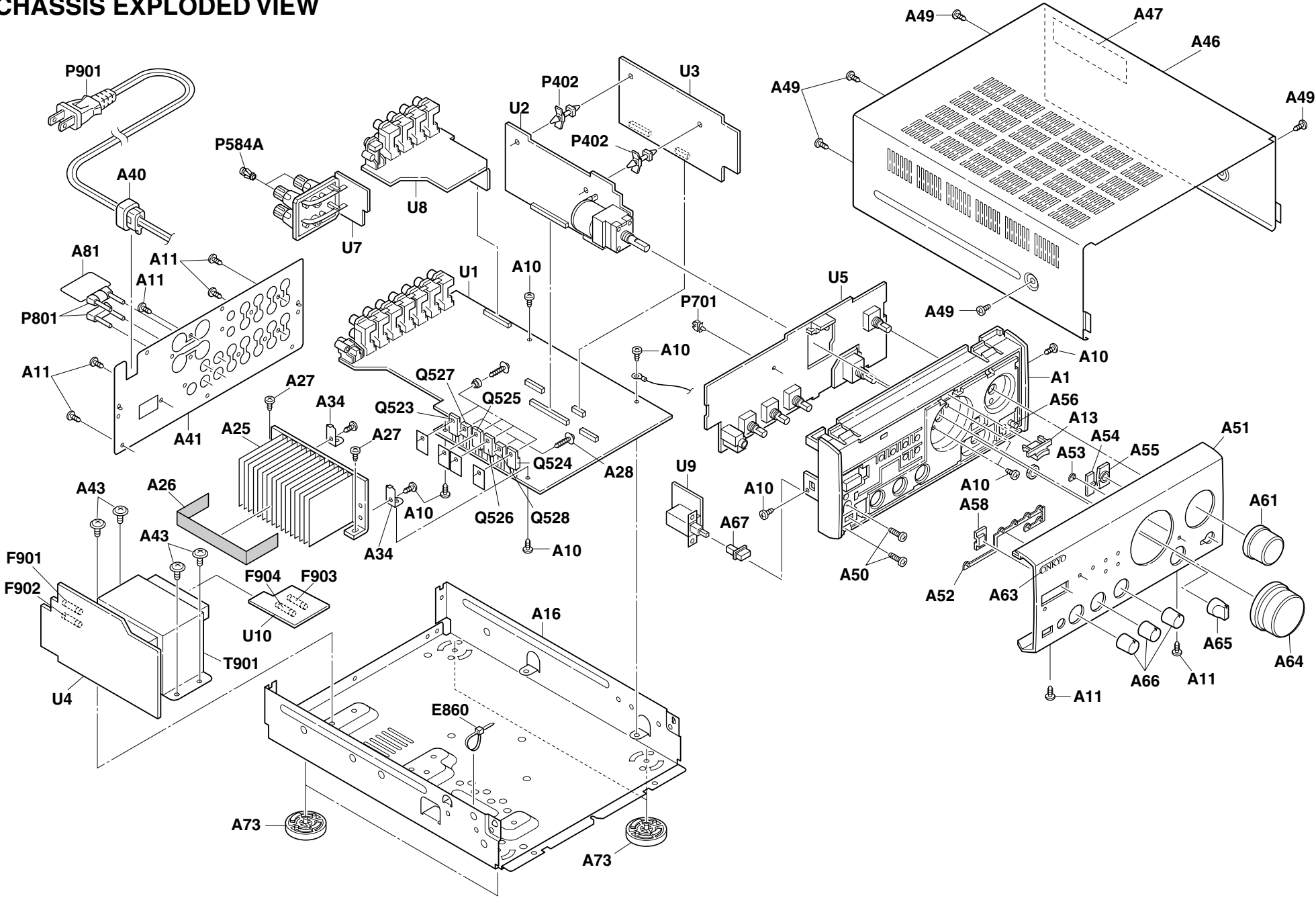

## CHASSIS EXPLODED VIEW PARTS LIST

REF NO.	PART NO.	DESCRIPTION	REF NO.	PART NO.	DESCRIPTION
A1	27111123	Front bracket	P402	27190011	KGLS-6S, Holder
A10	838130088	3TTB+8B, Self tapping screw	P584A	880009	Plastic rivet, NRP-345 <PT>
A11	838430088	3TTB+8B(BC), Self tapping screw	P701	27191106	UAMS-05S-2, Holder
A13	28198862	Facet, VOL	P801	25055436 or 25055945	NPLG-2P418, Shorted plug
A16	27100375D	Chassis			
A25	27160451B	Heat sink <DT>	P901	253277MIL	⚠ AS-UC-2#18, Power supply cord <DT>
	27160452B	Heat sink <PT>		253193HIT	⚠ AS-CEE, Power supply cord <PT>
A26	29110083	Adhesive tape, CROSS-16U	Q523,Q524	2202303 or	* 2SC4512-O or
A27	801525	3TTB+8B(BC), Special screw <PT>		2202304 or	* 2SC4512-Y or
	838430088	3TTB+8B(BC), Self tapping screw <DT>		2202305	* 2SC4512-P, Transistor
A28	801433	3SMS8W.SW+14B(BC), special screw	Q525,Q526	2202313 or	* 2SA1726-O or
A34	27141530A	Retainer, HS-2		2202314 or	* 2SA1726-Y or
A40	27300750	⚠ Bussing cord		2202315	* 2SA1726-P, Transistor
A41	27122831	Rear panel <DT>	Q527,Q528	2212654 or	* 2SC3421-Y or
	27122832	Rear panel <PT>		2212653	* 2SC3421-O, Transistor
A43	830440089	4TTC+8C(BC), Self tapping screw	T901	2301423	⚠ NPT-1374D, Power transformer <DT>
A46	28184759-1	Top cover		2301424	⚠ NPT-1374P, Power transformer <PT>
A47	29362571	Label, WARNING <DT,PT>	U1	1A905530-4B	NADG-6630-4B, Main circuit PC board ass'y <DT>
A49	838930088	3TTB+8B(UN), Self tapping screw		1A905530-4C	NADG-6630-4C, Main circuit PC board ass'y <PT>
A50	838430107	3TTB+10S(BC), Self tapping screw	U2	1A905531-4B	NAAF-6631-4B, Preamplifier circuit PC board ass'y <DT>
A51	27212298	Front panel		1A905531-4C	NAAF-6631-4C, Preamplifier circuit PC board ass'y <PT>
A52	28198894	Facet 7P	U3	1A905532-4B	NAAF-6632-4B, Acoustic circuit PC board ass'y <DT>
A53	28198895	Facet 1P		1A905532-4C	NAAF-6632-4C, Acoustic circuit PC board ass'y <PT>
A54	28198925	Facet A	U4	1A905533-4B	NAPS-6633-4B, Power supply circuit PC board ass'y <DT>
A55	27268037	Guide A		1A905533-4C	NAPS-6633-4C, Power supply circuit PC board ass'y <PT>
A56	28325133	Knob, FM	U5	1A905534-4B	NADIS-6634-4B, Display circuit PC board ass'y <DT>
A58	28191798	Clear plate, RE		1A905534-4C	NADIS-6634-4C, Display circuit PC board ass'y <PT>
A61	28325926	Knob, INPUT	U7	1A905536-4B	NAETC-6636-4B, Speaker terminal PC board ass'y <DT>
A63	28135247Y	Badge		1A905536-4C	NAETC-6636-4C, Speaker terminal PC board ass'y <PT>
A64	28325925	Knob, VOL	U8	1A905537-4B	NAETC-6637-4B, Terminal PC board ass'y <DT>
A65	28325674	Knob, TD		1A905537-4C	NAETC-6637-4C, Terminal PC board ass'y <PT>
A66	28325927	Knob, TONE	U9	1A905539-4B	NAETC-6639-4B, Power switch PC board ass'y <DT>
A67	28325673	Knob, POWER		1A905539-4C	NAETC-6639-4C, Power switch PC board ass'y <PT>
A73	27175323	Leg AS	U10	1A905540-4C	NAETC-6640-4C, Fuse PC board ass'y <PT>
A81	29362630	Label, PROCESSOR			
F901	252158	⚠ 1.6A-UL/T-237, Fuse <DT>			
	252069	⚠ 0.8A-SE-EAK FSBFUSE, Fuse <PT>			
F902-F904	252075	⚠ 2.5A-SE-EAK FUSE <PT>			

**NOTE: THE COMPONENTS IDENTIFIED BY MARK ⚠ ARE CRITICAL FOR RISK OF FIRE AND ELECTRIC SHOCK. REPLACE ONLY WITH PART NUMBER SPECIFIED.**

**NOTE:**

&lt;DT&gt; : Asian model only for 120V

&lt;PT&gt; : Asian model only for 230V

**CAUTION :**

Replacement of the transistor of mark \* ,if necessary, must be made from the same beta group(HFE) as the original type.

A B C D E F G

SCHEMATIC DIAGRAM-1

1  
2  
3  
4  
5

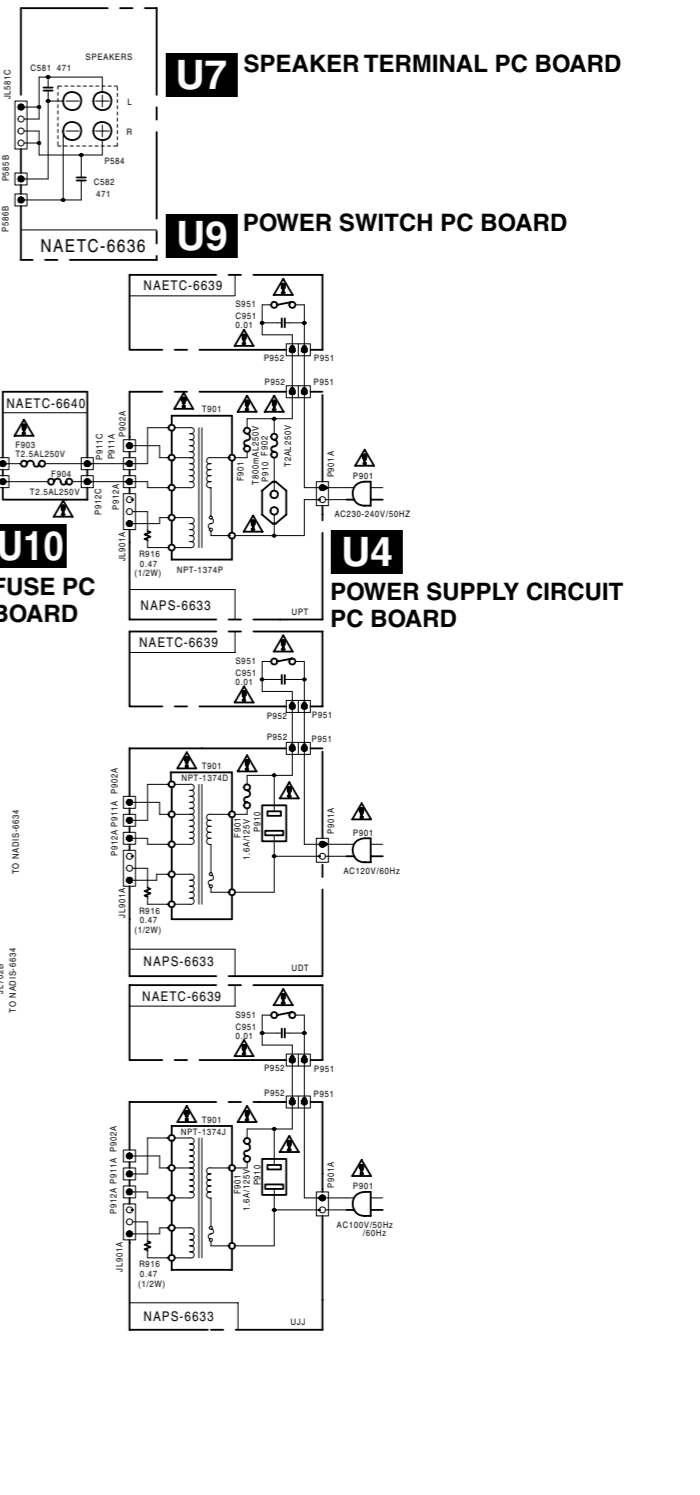
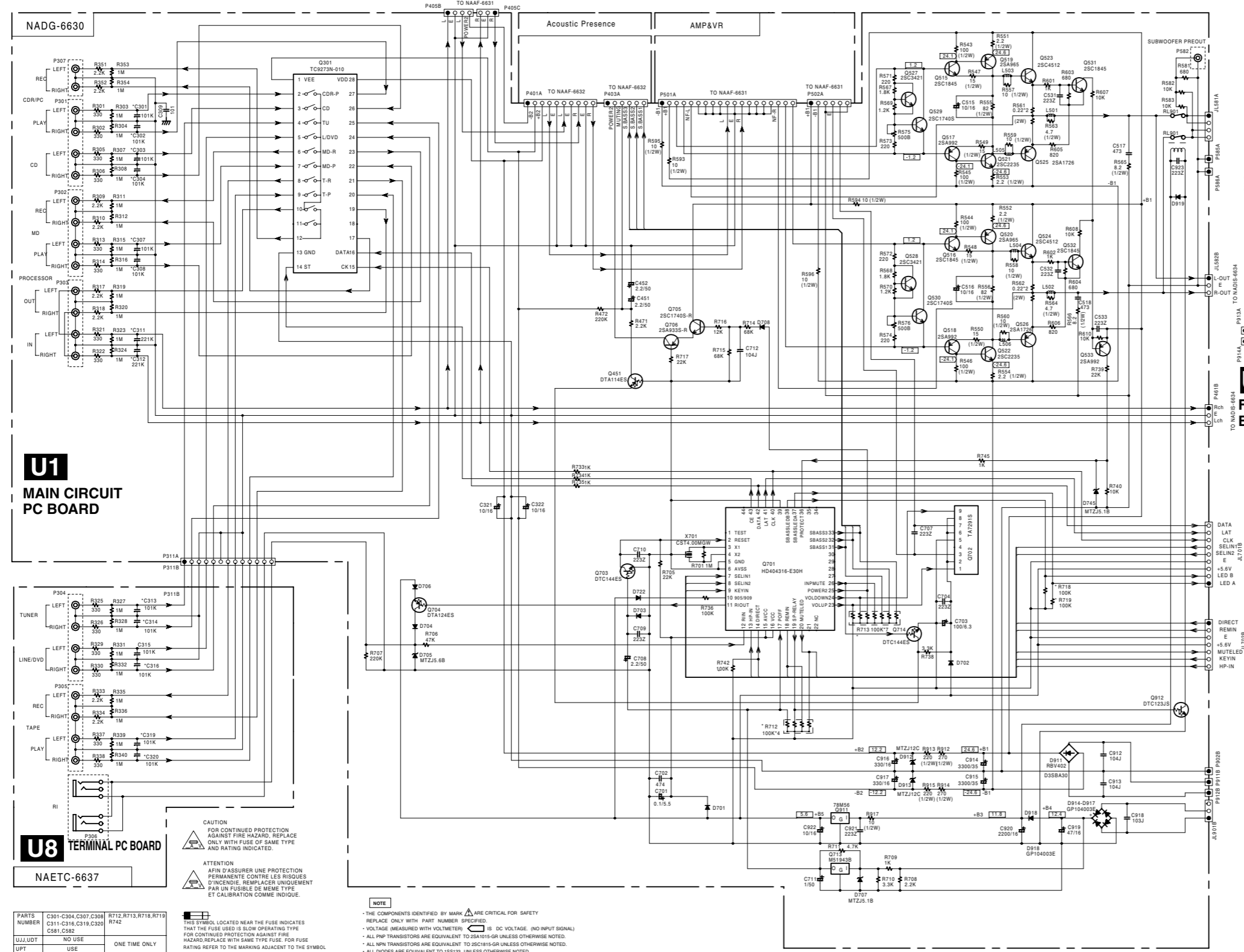

**U8 TERMINAL PC BOARD**  
NAETC-6637

CAUTION  
FOR CONTINUED PROTECTION  
AGAINST FIRE HAZARD, REPLACE  
ONLY WITH FUSE OF SAME TYPE  
AND RATING INDICATED.

ATTENTION  
AFIN D'ASSURER UNE PROTECTION  
PERMANENTE CONTRE LES RISQUES  
D'INCENDIE, REMPLACER UNIQUEMENT  
PAR UN FUSIBLE DE MEME TYPE  
ET CALIBRAGE COMME INDIQUE.

PARTS NUMBER	C301-C304, C307, C308 C311-C316, C319, C320 C381, C382	R712, R713, R718, R719 R742
UJJ, UDT	NO USE	ONE TIME ONLY
UPT	USE	

**NOTE**

- THE COMPONENTS IDENTIFIED BY MARK ARE CRITICAL FOR SAFETY. REPLACE ONLY WITH PART NUMBER SPECIFIED.
- VOLTAGE (MEASURED WITH VOLTMETER) IS DC VOLTAGE. (NO INPUT SIGNAL).
- ALL PNP TRANSISTORS ARE EQUIVALENT TO 2SA1015-GR UNLESS OTHERWISE NOTED.
- ALL NPN TRANSISTORS ARE EQUIVALENT TO 2SC1815-GR UNLESS OTHERWISE NOTED.
- ALL DIODES ARE EQUIVALENT TO 1S813 UNLESS OTHERWISE NOTED.
- ELECTROLYTIC CAPACITORS ( ) ARE IN  $\mu$ F/W.
- ALL CAPACITORS ARE IN pF/50V UNLESS OTHERWISE NOTED.
- EX) 030-3pF 330-33pF 331-330pF 333-0.033 $\mu$ F
- ALL RESISTORS ARE IN OHMS  $\mu$ WATTS UNLESS OTHERWISE NOTED.
- THE THICK LINES ON PC BOARD ARE THE PRINTING SIDE OF THE PARTS.
- EX) -PRINTING SIDE
- CIRCUIT IS SUBJECT TO CHANGE FOR IMPROVEMENT.

# SCHEMATIC DIAGRAM-2

1

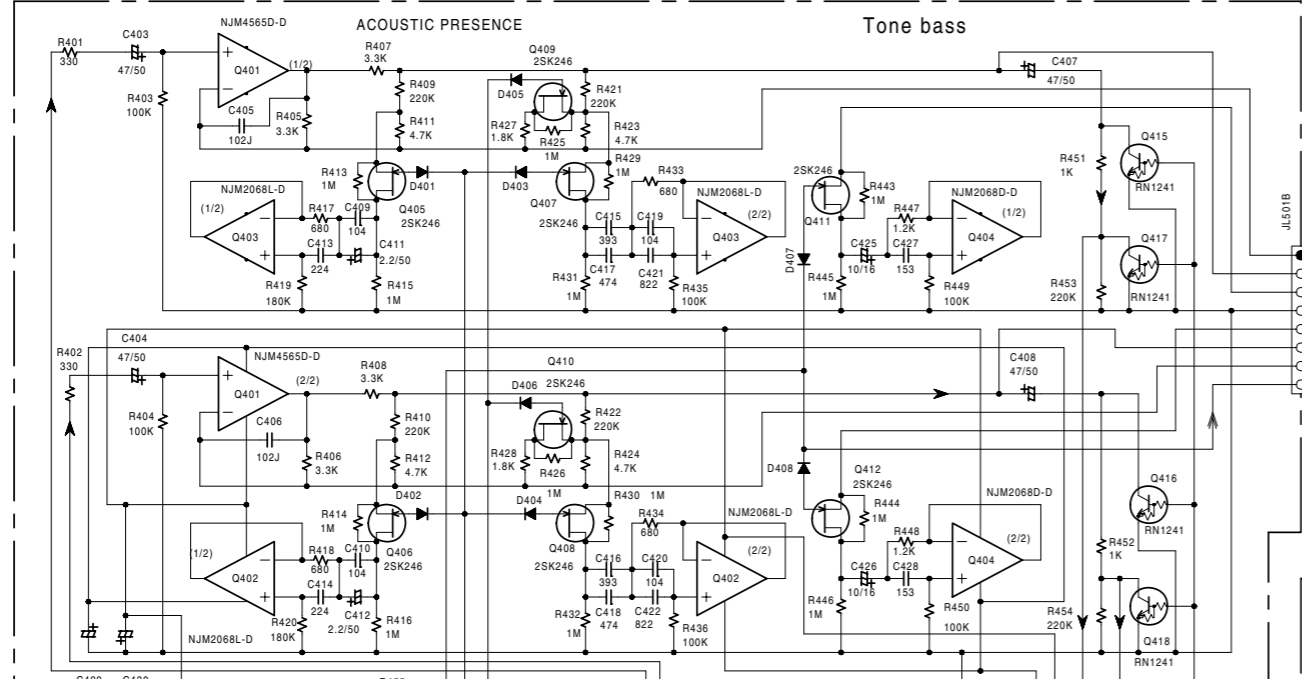

2



3

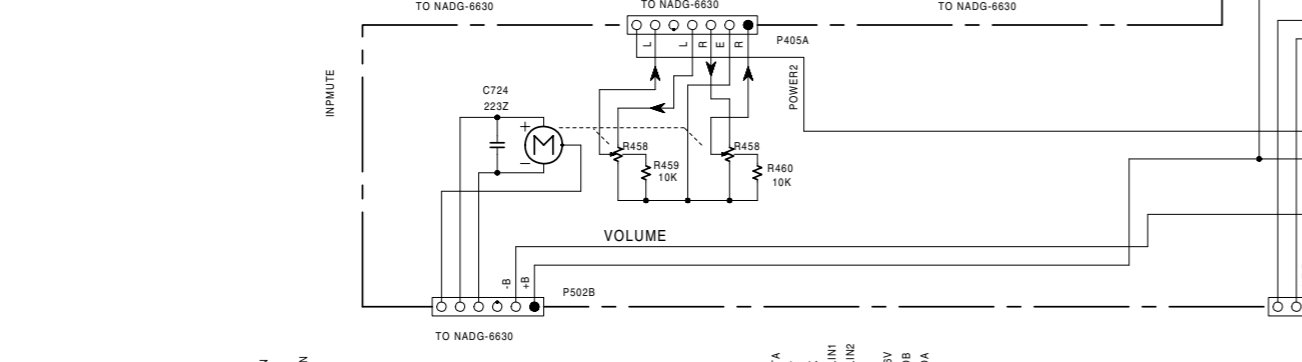

4

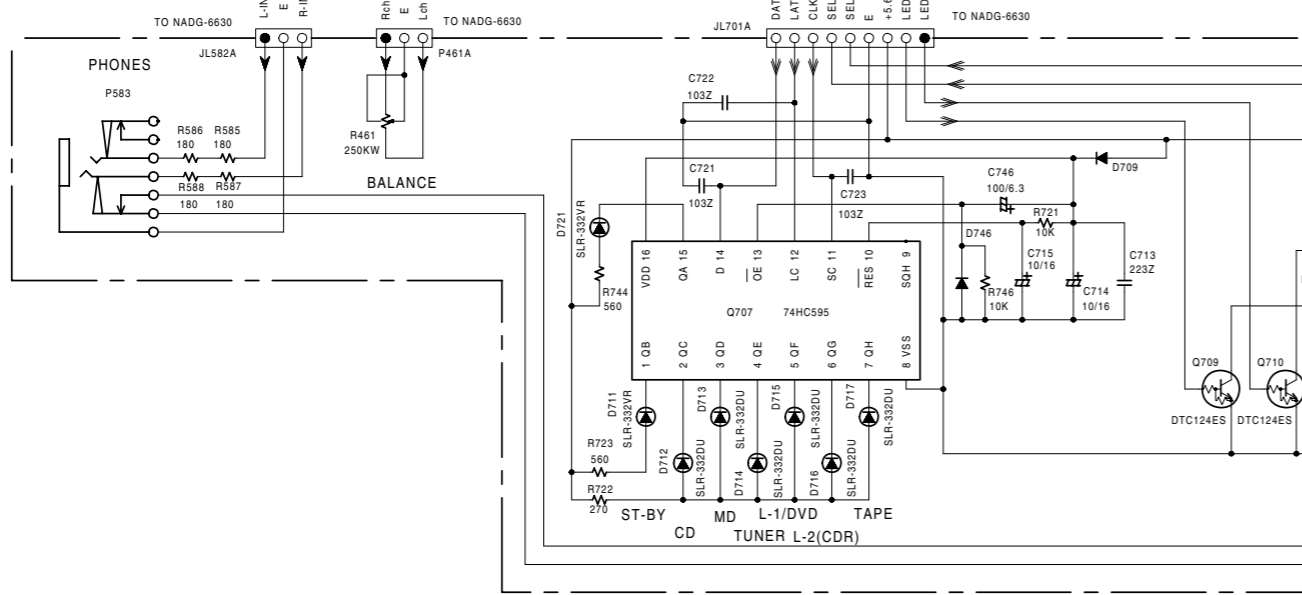

5

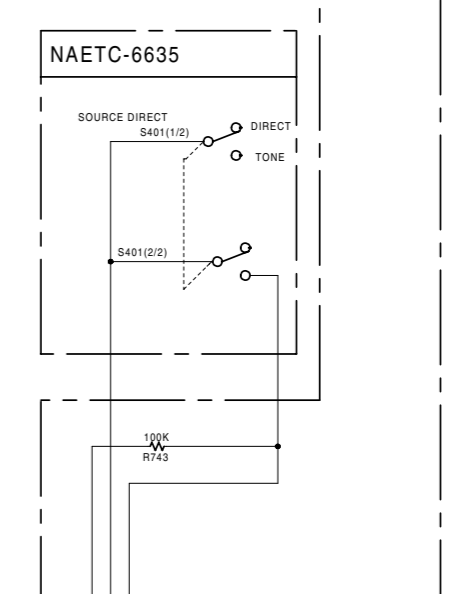
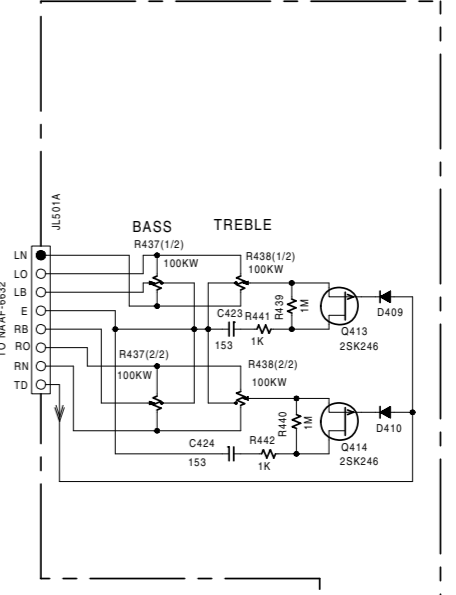
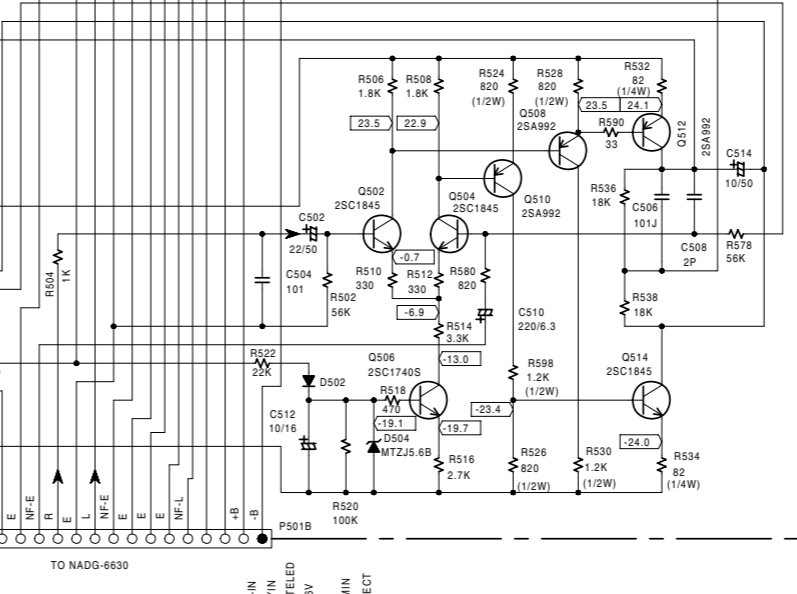
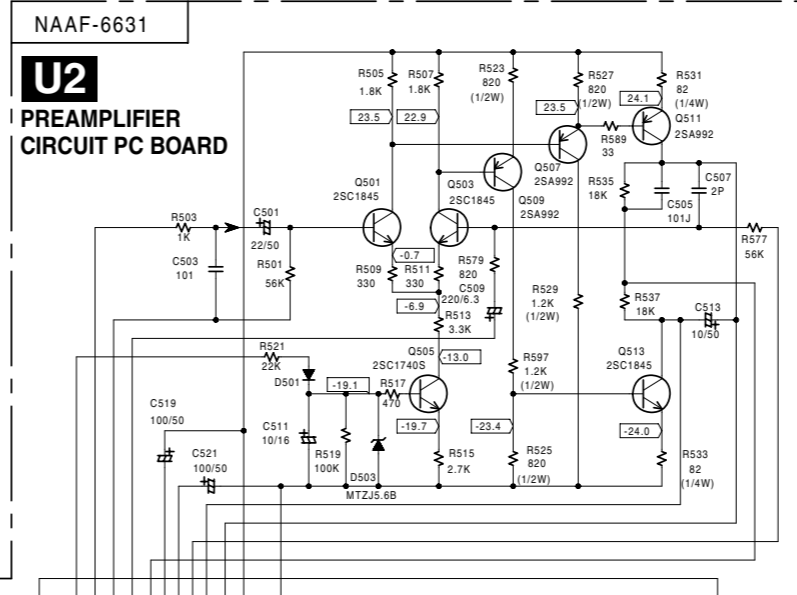

NADIS-6634

# PC BOARD CONNECTION DIAGRAM

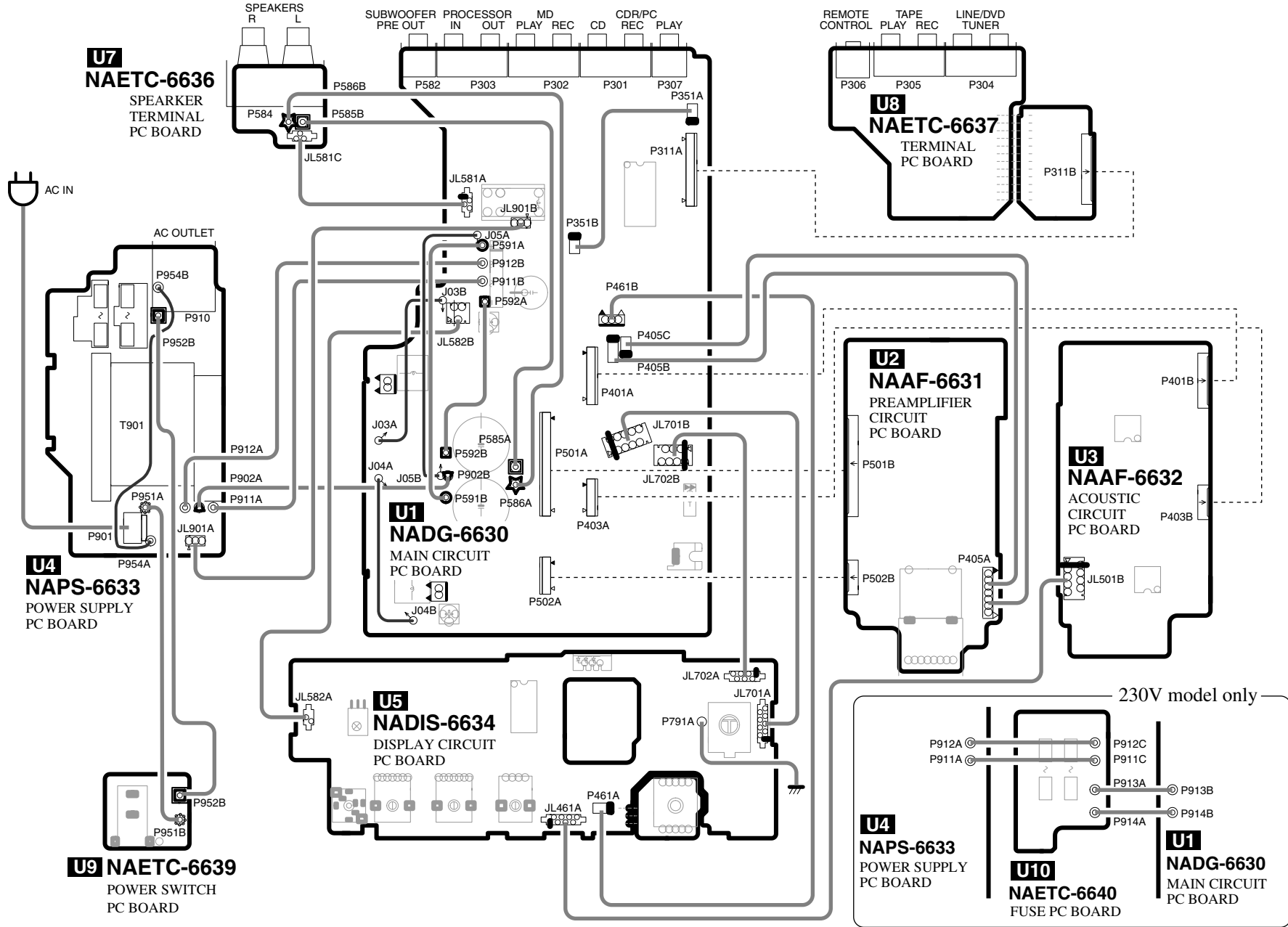

## PRINTED CIRCUIT BOARD PARTS LIST-1

## U1

## MAIN CIRCUIT PC BOARD (NADG-6630-4B/C)

CIRCUIT NO.	PART NO.	DESCRIPTION
Q301	22240881	TC9273N-010
Q701	22241481	HD404316E30H
Q702	22240239	TA7291S
Q713	222951	M51943B
Q911	222780565JRC	NJM78M56FA
<b>Transistors</b>		
Q405,Q406	2211945	2SK246-GR
Q451	2213510 or 2215770	DTA114ES or KRA102M
Q515,Q516	2211733 or 2211732	2SC1845-E or 2SC1845-F
Q517,Q518,Q533	2211792 or 2211793	2SA992-F or 2SA992-E
Q519,Q520	2211643 or 2211644	2SA965-O or 2SA965-Y
Q521,Q522	2211653 or 2211654	2SC2235-O or 2SC2235-Y
Q529,Q530,Q705	2213284	2SC1740S-R
Q531,Q532	2211733 or 2211732	2SC1845-E or 2SC1845-F
Q703,Q714	221282 or 2215820	DTC144ES or KRC104M
Q704	2212600 or 2215780	DTA124ES or KRA103M
Q706	2213354	2SA933S-R
Q912	2213640	DTC123JS
<b>Diodes</b>		
D701,D703,D704	223163 or 223205	1SS133 or 1SS270A
D702,D914-D918	22380035 or 22380046	GP104003E or AM01Z
D705	224470562	MTZJ5.6B
D706,D708	223163 or 223205	1SS133 or 1SS270A
D707,D745	224470512	MTZJ5.1B
D722,D919	223163 or 223205	1SS133 or 1SS270A
D911	22380022F or 22380271F	RBV402 or D3SBA20
D912,D913	224471203	MTZJ12C
<b>Oscillator</b>		
X701	3010150	CST4.00MGW
<b>Coils</b>		
L503-L506	5597-45502	FR core
<b>Capacitors</b>		
C301-C304	374721015	100pF+/-10%, 50V, Plastic
C307,C308	374721015	100pF+/-10%, 50V, Plastic
C311,C312	374722215	220pF+/-10%, 50V, Plastic
C321,C322,C922	393341007	10uF, 16V, Elect.
C407,C408	393384707	47uF, 50V, Elect.
C451,C452	353780229	2.2uF, 50V, Elect.
C503,C504	374721015	100pF+/-10%, 50V, Plastic
C515,C516	393381007	10uF, 50V, Elect.
C517,C518	374724734	0.047uF+/-5%, 50V, Plastic
C701	3000078 or 3000076	DX-5R5L104 or EECS5R5T104, Super capacitor
C702	375524744	MMT50V-474J
C703	354721019	100uF, 6.3V, Elect.
C708	354780229	2.2uF, 50V, Elect.
C711	354780109	1uF, 50V, Elect.
C712,C912,C913	374721044	0.1uF+/-5%, 50V, Plastic
C914,C915	3504317	3300uF, 35V, Elect.
C916,C917	354743319	330uF, 16V, Elect.
C918	374721034	0.01uF+/-5%, 50V, Plastic
C919	354744709	47uF, 16V, Elect.
C920	354742229S	2200uF, 16V, Elect.
L501,L502	231176S	S-1.3C
<b>Resistors</b>		
R543-R546	443521014	100ohm +/-5%, 1/2W, Metal oxide
R547-R550	443521504	15ohm +/-5%, 1/2W, Metal oxide
R551-R554	453530224	2.2ohm +/-5%, 1/2W, Metal oxide
R555,R556	443528204	82ohm +/-5%, 1/2W, Metal oxide
R557-R560	443521004	10ohm +/-5%, 1/2W, Metal oxide
R561,R562	4500027	MPC708-2WK-0.22

CIRCUIT NO.	PART NO.	DESCRIPTION
R563,R564	453530474	4.7ohm +/-5%, 1/2W, Metal oxide
R565,R566	453530824	8.2ohm +/-5%, 1/2W, Metal oxide
R575,R576	5210257	N06HR500BC, Trimming
R593-R596,R917	443521004	10ohm +/-5%, 1/2W, Metal oxide
R912-R915	443522714	270ohm +/-5%, 1/2W, Metal oxide
<b>Rotary encoder</b>		
R732	25065534	REB161PVB
<b>Relay</b>		
RL901	25065597	NRL-2P8A-DC12-147
<b>Jacks</b>		
P582	25045302	NPJ-1PDBL161
P301-P303	25045303	NPJ-4PDBL162
P307	25045307	NPJ-2PDBL166
<b>Sockets</b>		
JL581A	25051088	NSCT-4P875
JL582B	25055624	NPLG-3P586
JL701B	25055630	NPLG-9P592
JL702B	25055628	NPLG-7P590
JL901A,JL901B	25051107	NSCT-3P894
P311A	25055709	NPLG-13P665
P351	2009990230	NSAS-6P0333
P401A	25055706	NPLG-10P662
P403A,P502A	25055702	NPLG-6P658
P405	2009990565UL	NSAS-14P0758
P461B	25055133	NPLG-3P117
P501A	25055808	NPLG-19P764
P503,P504	25055038	NPLG-2P29
<b>Retainer</b>		
E851	27141749	(BUS)

## U2

## PREAMPLIFIER CIRCUIT PC BOARD (NAAF-6631-4B/C)

CIRCUIT NO.	PART NO.	DESCRIPTION
<b>Transistors</b>		
Q501-Q504 or	2211732 or 2211733	2SC1845-F or 2SC1845-E
Q505,Q506	2213284	2SC1740S-R
Q507-Q512 or	2211792 or 2211793	2SA992-F or 2SA992-E
Q513,Q514 or	2211732 or 2211733	2SC1845-F or 2SC1845-E
<b>Diodes</b>		
D501,D502	223163 or 223205	1SS133 or 1SS270A
D503,D504	224470562	MTZJ5.6B
<b>Capacitors</b>		
C511,C512	354741009	10uF, 16V, Elect.
C509,C510	393322217	220uF, 6.3V, Elect.
C513,C514	393381007	10uF, 50V, Elect.
C519-C522	393381017	100uF, 50V, Elect.
C501,C502	393382207	22uF, 50V, Elect.
<b>Resistors</b>		
R529,R530	443521224	1.2kohm +/-5%, 1/2W, Metal oxide
R597,R598	443521224	1.2kohm +/-5%, 1/2W, Metal oxide
R523-R528	443528214	820ohm +/-5%, 1/2W, Metal oxide
R531-R534	415428203	82ohm +/-5%, 1/4W, Carbon
R458	5104383	+N16RGL100KBT20F, Volume
<b>Sockets</b>		
P502B	25051231	NSCT-6P1021
P501B	25051530	NSCT-19P1317
P405A	25055137	NPLG-7P121

## NOTE:

&lt;DT&gt; : Asian model only for 120V

&lt;PT&gt; : Asian model only for 230V

**NOTE: THE COMPONENTS IDENTIFIED BY MARK  ARE CRITICAL FOR RISK OF FIRE AND ELECTRIC SHOCK. REPLACE ONLY WITH PART NUMBER SPECIFIED.**



## PRINTED CIRCUIT BOARD PARTS LIST-2

## U3

## ACOUSTIC CIRCUIT PC BOARD (NAAF-6632-4B/C)

CIRCUIT NO.	PART NO.	DESCRIPTION
	<b>ICs</b>	
Q401	22240191	NJM4565D-D
Q402,Q403	22240250	NJM2068L-D
Q404	222956	NJM2068D-D
	<b>Transistors</b>	
Q407,Q408	2211945	2SK246-GR
Q411,Q412	2211945	2SK246-GR
Q415,Q418	2213631 or 2213632	RN1241-A or RN1241-B
	<b>Diodes</b>	
D401-D408	223163 or 223205	1SS133 or 1SS270A
	<b>Capacitors</b>	
C405,C406	374721024	1000pF+/-5%, 50V, Plastic
C409,C410	374721044	0.1uF+/-5%, 50V, Plastic
C419,C420	374721044	0.1uF+/-5%, 50V, Plastic
C427,C428	374721534	0.015uF+/-5%, 50V, Plastic
C413,C414	374722244	0.22uF+/-5%, 50V, Plastic
C415,C416	374723934	0.039uF+/-5%, 50V, Plastic
C417,C418	374724744	0.47uF+/-5%, 50V, Plastic
C421,C422	374728224	8200pF+/-5%, 50V, Plastic
C425,C426	393341007	10uF, 16V, Elect.
C429,C430	393341007	10uF, 16V, Elect.
C411,C412	393380227	2.2uF, 50V, Elect.
C403,C404	393384707	47uF, 50V, Elect.
	<b>Sockets</b>	
P403B	25051231	NSCT-6P1021
P401B	25051235	NSCT-10P1025
JL501B	25055629	NPLG-8P591

## U4

## POWER SUPPLY PC BOARD (NAPS-6633-4B/4C)

CIRCUIT NO.	PART NO.	DESCRIPTION
	<b>Resistors</b>	
R916	453534794	$\Delta$ 0.47ohm $\pm$ 5%, 1/2W, Metal oxide
	<b>Socket</b>	
P910	25051637	$\Delta$ NSCT-2P1424, AC Outlet <PT>
	<b>Plug</b>	
P901A	25055676	$\Delta$ NPLG-2P632
	<b>Fuse holder</b>	
F901	25050065	$\Delta$ YSH403T <JJ>
F902	25050065	$\Delta$ YSH403T <PT>
	<b>Fuse label</b>	
F901C	29362519	$\Delta$ T800mAL250V <PT>

## U5

## DISPLAY CIRCUIT PC BOARD(NADIS-6634-4B/AC)

CIRCUIT NO.	PART NO.	DESCRIPTION
	<b>ICs</b>	
Q707	222745955	74HC595P
	<b>Remote sensor</b>	
U701	241307	GPIU271X
	<b>Transistors</b>	
Q409,Q410	2211945	2SK246-GR
Q413,Q414	2211945	2SK246-GR
Q708	2213290 or 2215960	DTC114ES or KRC102M
Q709,Q710	2213160 or 2215810	DTC124ES or KRC103M
Q711,Q712	2213510 or 2215770	DTA114ES or KRA102M
	<b>Diodes</b>	
D409,D410	223163 or 223205	1SS133 or 1SS270A
D709,D710,D746	223163 or 223205	1SS133 or 1SS270A
D711	225338	SLR-332VR
D720	225339	SPR-39MVWF
D712-D717,D721	225340	SLR-332DU
D723	225374	SEL2E10C

CIRCUIT NO.	PART NO.	DESCRIPTION
	<b>Capacitors</b>	
C746	353721019	100uF0, 6.3V, Elect.
C714,C715	353741009	10uF, 16V, Elect.
C717,C718	353741009	10uF, 16V, Elect.
C423,C424	374721534	0.015uF $\pm$ 5%, 50V, Plastic
	<b>Resistors</b>	
R437	5104341	N14RHC100KWT20Z, Bass
R438	5104341	N14RHC100KWT20Z, Treble
R461	5104407	N12RGLC250KWT20, Balance
	<b>Rotary switch</b>	
S401	25030415	NRSF-122-15SRB, Source direct
	<b>Push switch</b>	
S701,S702	25035699	NPS-111-S662
	<b>Jacks</b>	
P583	25045396	LGT1516-0101, Headphone jack
	<b>Socket AS</b>	
P461A	2009990296	NSAS-6P0429
	<b>Holders</b>	
JL582A	25051087	NSCT-3P874
JL702A	25051091	NSCT-7P878
JL501A	25051092	NSCT-8P879
JL701A	25051093	NSCT-9P880
	<b>LED Holder</b>	
D723A	27191018A	(LED)

## U7

## SPEAKER TERMINAL PC BOARD(NAETC-6636-4B/4C)

CIRCUIT NO.	PART NO.	DESCRIPTION
	<b>Terminal</b>	
P584	25060193	NTM-4PDMN115, Speakers
	<b>Wire holder</b>	
JL581C	25051088	NSCT-4P875

## U8

## TERMINAL PC BOARD (NAETC-6639-4B/4C)

CIRCUIT NO.	PART NO.	DESCRIPTION
	<b>Capacitors</b>	
C313-C316	374721015	100pF $\pm$ 10%, 50V, Plastic
C319,C320	374721015	100pF $\pm$ 10%, 50V, Plastic
	<b>Jacks</b>	
P304,P305	25045303	NPJ-4PDBL162
P306	25045330	NPJ-2PDBL184
	<b>Socket</b>	
P311B	25051238	NSCT-13P1028

## U9

## POWER SWITCH PC BOARD (NAETC-6639-4B/4C)

CIRCUIT NO.	PART NO.	DESCRIPTION
	<b>Capacitors</b>	
C951	3300055	$\Delta$ DE1610F103M-KH
	<b>Switch</b>	
S951	25035550	$\Delta$ NPS-111-L512P, Power
	<b>Cover</b>	
C951A	27301216	$\Delta$ SB1925A <PT>

## U10

## FUSE PC BOARD (NAETC-6640-4C)

CIRCUIT NO.	PART NO.	DESCRIPTION
	<b>Fuse holders</b>	
F903,F904	25050065	$\Delta$ YSH403T <PT>

## NOTE:

<DT> : Asian model only for 120V  
<PT> : Asian model only for 230V

**NOTE: THE COMPONENTS IDENTIFIED BY MARK  $\Delta$  ARE CRITICAL FOR RISK OF FIRE AND ELECTRIC SHOCK. REPLACE ONLY WITH PART NUMBER SPECIFIED.**

# MICROPROCESSOR TERMINAL DESCRIPTION

## Q701:HD404316-E30H

Pin No.	Function	I/O	Descriptions
1	TEST	I	Test pin.
2	RESET	I	System reset input pin.
3	OSC1	I	Pins to connect the ceramic oscillator 4.0MHz.
4	OSC2	O	
5	GND	I	Ground pin.
6	AVSS	I	Analog reference ground for A/D converter.
7	SEL IN-1	I	Rotary switch connection input pin for input selector.
8	SEL IN-2	I	
9	KEY IN	I	Operation key connection pin.
10	905/909	I	Initializing input pin for model selector.
11	RI OUT	O	System code output pin.
12	RI IN	I	System code input pin.
13	HP IN	I	Head phone switch position detector pin.
14	DIRECT	I	Direct switch position detector pin.
15	AVCC	I	Analog reference voltage for A/D converter.
16	VCC	I	Power supply pin (+5V).
17	POFF	I	Power failure detector pin.
18	REM IN	I	Remote control signal input pin.
19	NC	O	Speaker relay control signal output pin.
20	MUT LED	O	MUTING indicator control pin. Light on and off when the muting circuit turns on.
21	NC	I	No connection.
22	NC		
23	VOL UP	O	Volume control output pin.
24	VOL DOWN	O	Volume control output pin.
25	POWER 2		Power amplifier control output pin.
26	INPMUT	O	Muting control output pin.
27	NC		Connect to the ground.
28	NC		Connect to the ground.
29	NC		
30	NC		
31	SBASS-1	O	
32	SBASS-2	O	Acoustic Presence control output pin.
33	SBASS-3	O	
34	NC		Connect to the ground.
35	NC		Connect to the ground.
36	PROTECT	I	Speaker protect signal detector pin.
37	SBASS LEDA	O	Acoustic Presence indicator output pin.
38	SBASS LEDB	O	Acoustic Presence indicator output pin.
39	NC		Connect to the ground.
40	CLK	O	Clock output pin of source selector and indicator ICs.
41	LAT	O	Latch output pin of source indicator IC.
42	DATA	O	Data output pin of source selector and indicator ICs.
43	CE	O	Chip enable output pin of source selector IC.
44	NC		No connection.

# MICROPROCESSOR CONNECTION DIAGRAM

Q701:HD404316E04H

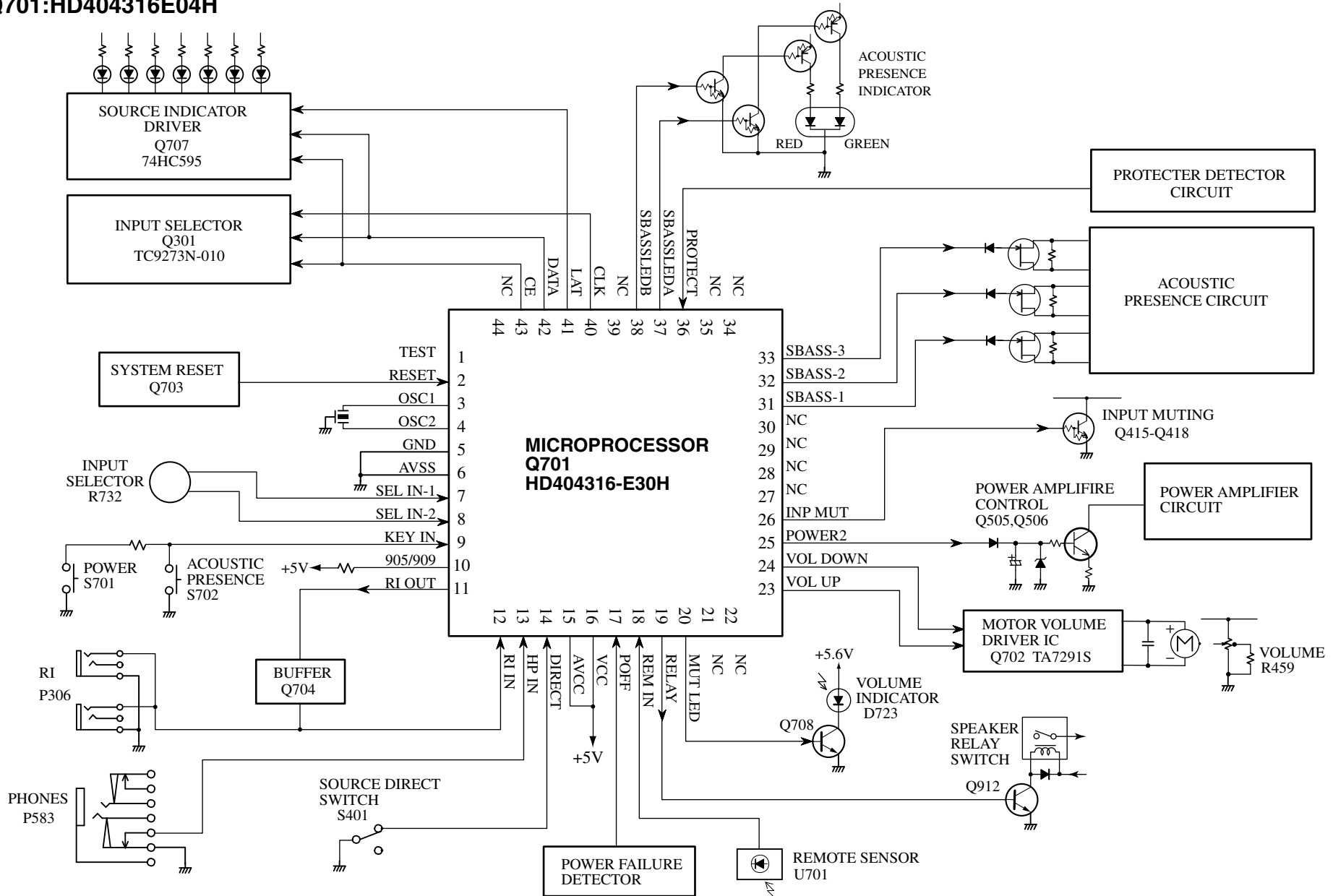

## ADJUSTMENT PROCEDURES

### IDLING CURRENT ADJUSTMENT

1. Before Idling adjustment, turn the trimming resistors R575, R576 to counter clockwise.
2. Connect the DC voltmeter to terminal P503, P504.
3. After turn POWER to ON, adjust the trimming resistors R575, R576 so that the reading of voltmeter becomes 2.0 mV.
4. After adjustment, attach the top cover.
5. Confirm the voltage of above points after five minutes.
6. When less than 2.5 mV : Readjust the trimming resistors above so that the voltage becomes 3.0 mV.  
When 2.6 mV to 4.0 mV : It is not necessary to adjust.  
When more than 4.1 mV : Readjust the trimming resistors above so that the voltage becomes 3.5 mV.

**Note:**No load and No signal

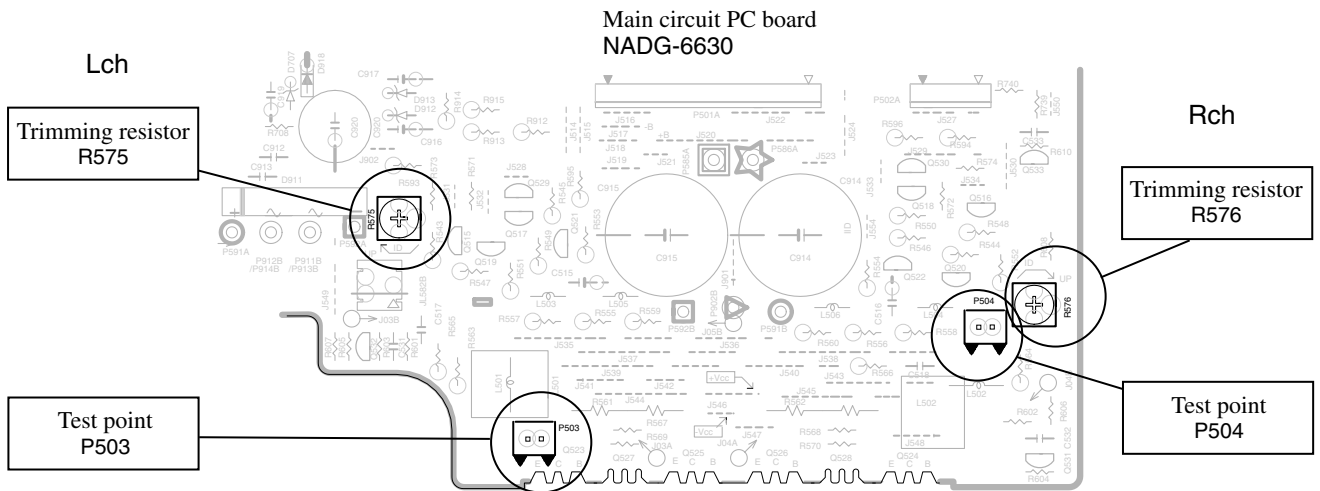

## CONFIRMATION

### CONFIRMATION OF PROTECTION CIRCUIT

Confirmation of Current detection circuit

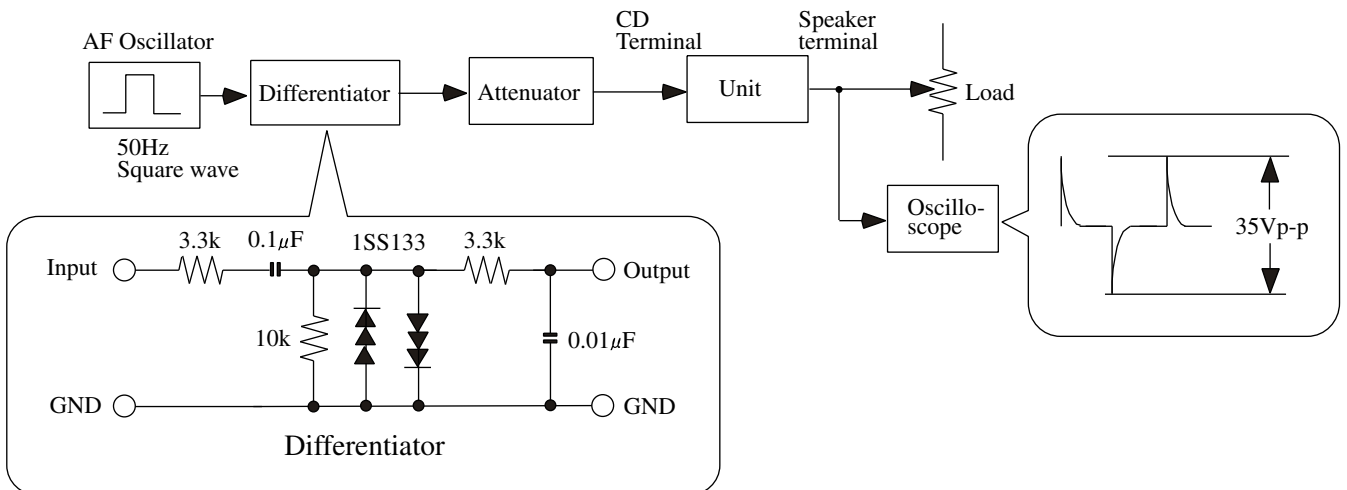

1. Connect Differentiator below and apply the 50Hz square signal to the CD terminal.
2. Adjust the attenuator or Volume so that the output level becomes 35V p-p.
3. Confirm that the speaker relay turns OFF when a 0.5 ohm load is connected.



# PAD ASSEMBLY PROCEDURES-1

## ASSEMBLING OF PAD A

Procedures : ① to ⑤

----- : Line shows folding direction   
----- : Line shows folding direction 

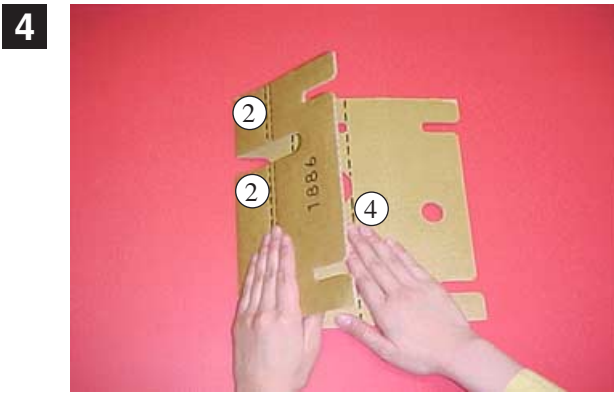
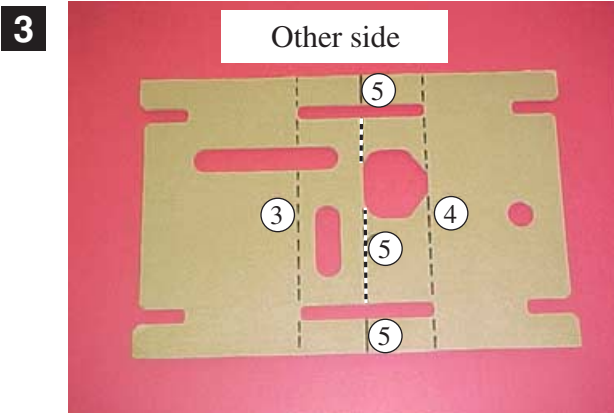
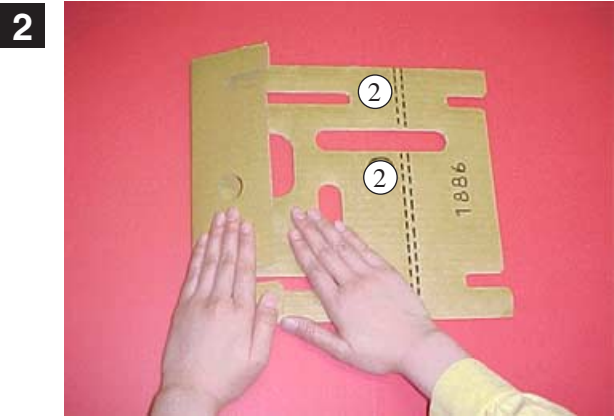
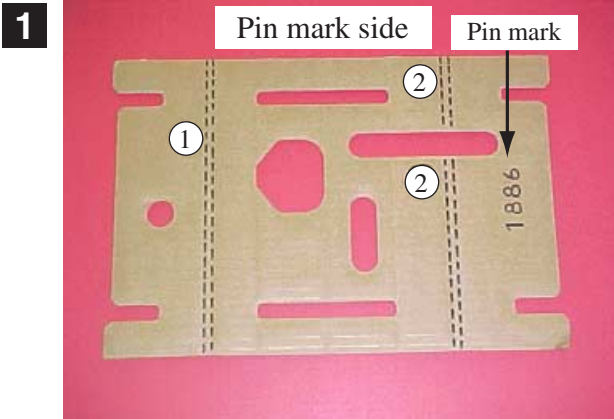

# PAD ASSEMBLY PROCEDURES-2

## ASSEMBLING OF PAD B

Procedures : ① to ⑤      - - - - : Line shows folding direction (↘↗)

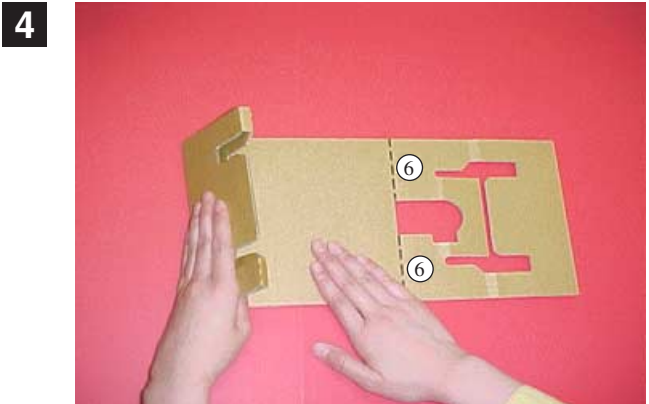
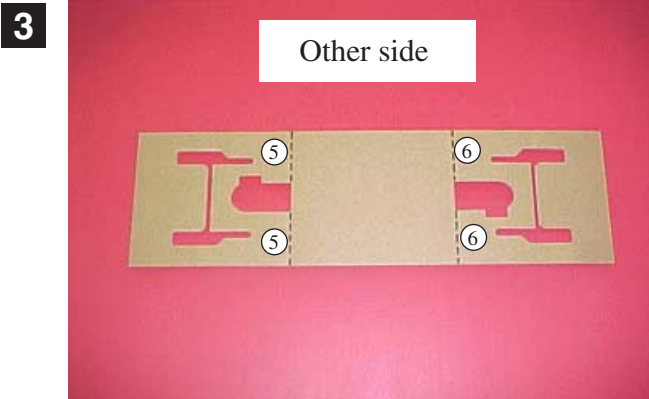
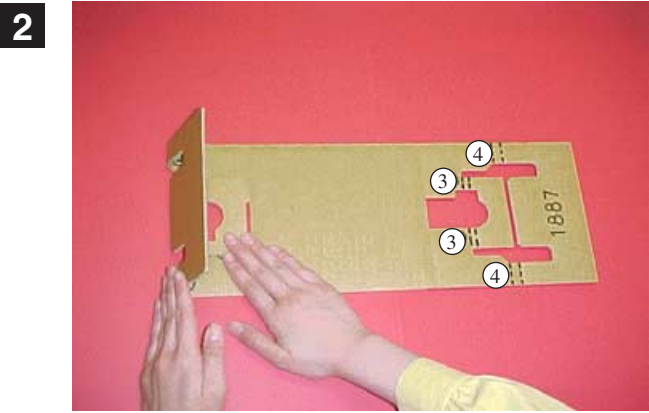
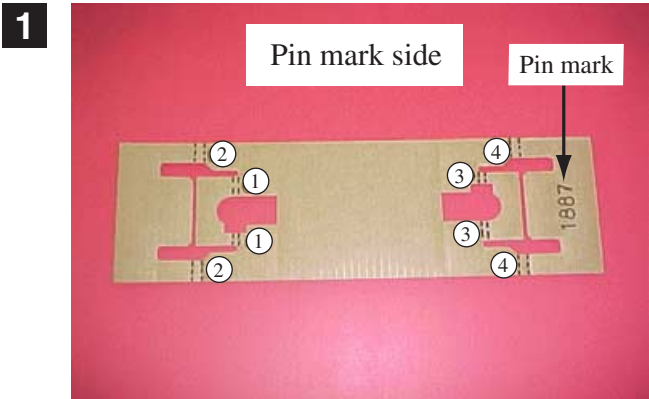

# PAD ASSEMBLY PROCEDURES-3

## INSERT PAD A TO PAD B

1

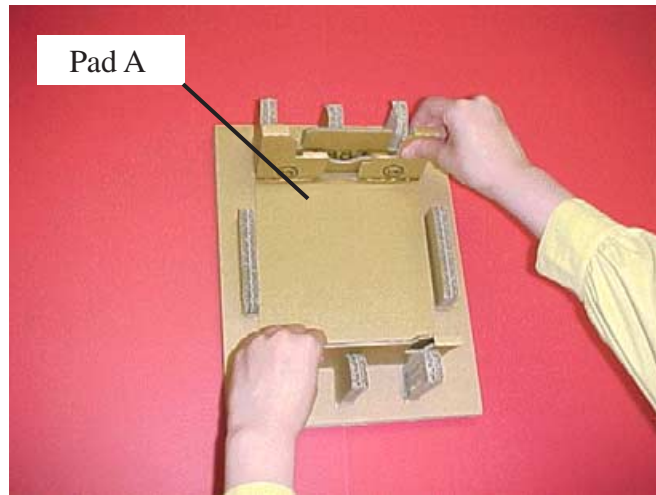

2

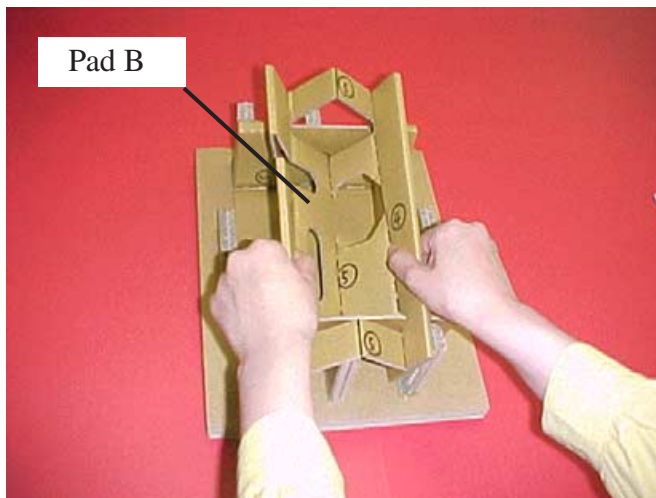

3

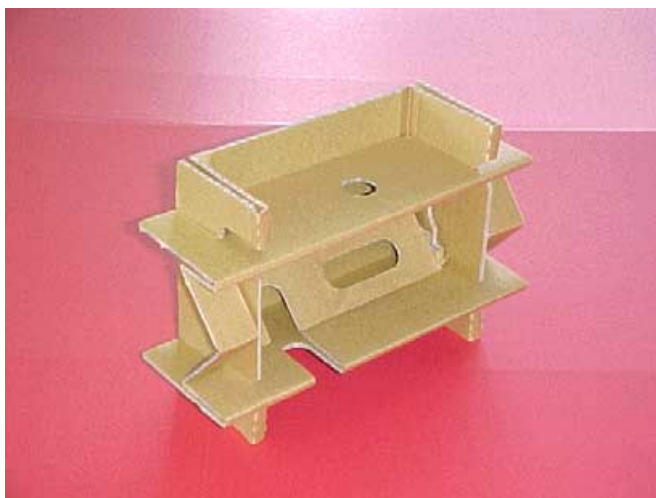

PACKING VIEW

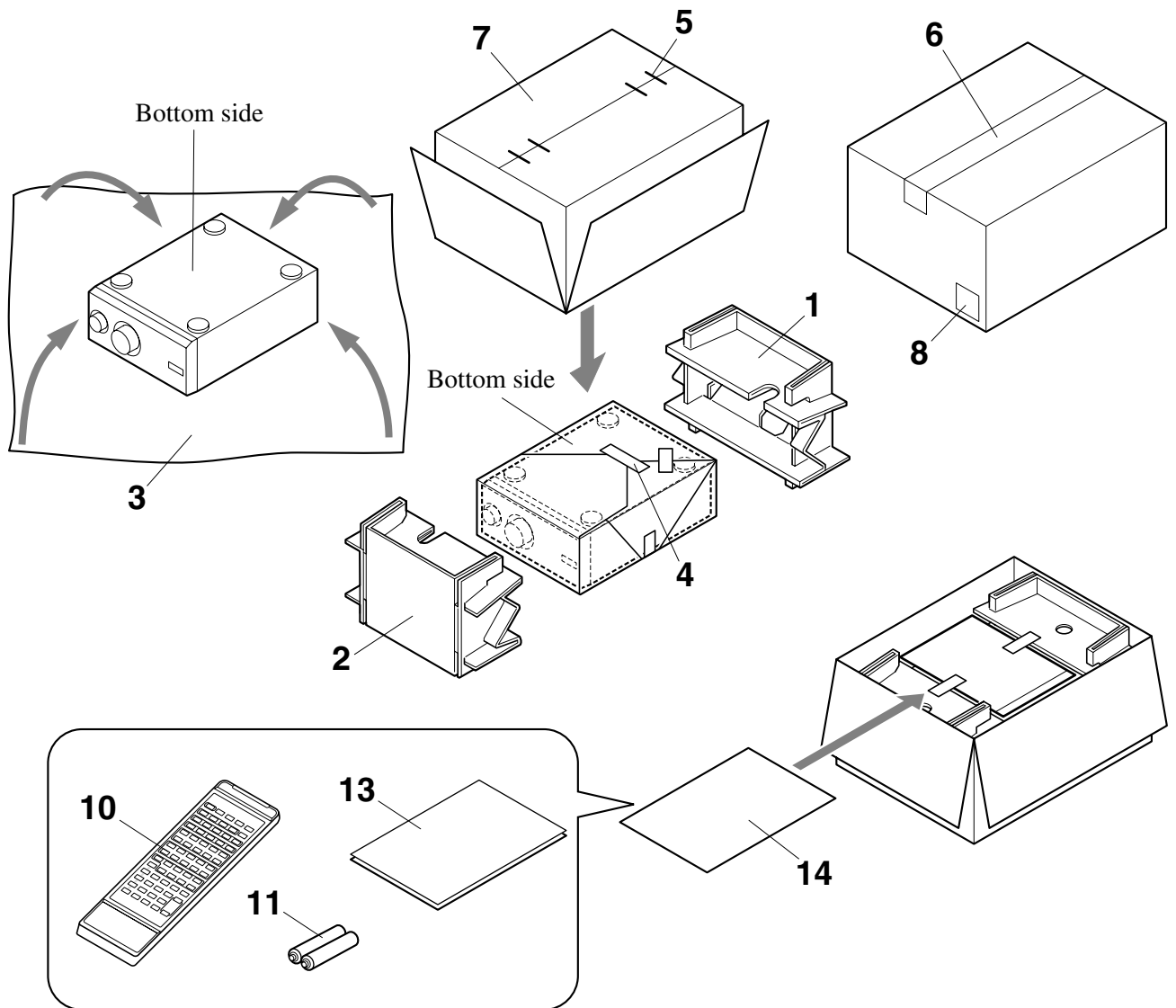

**PARTS LIST**

REF NO.	PART NO.	DESCRIPTION
1	29091886	Pad A
2	29091887	Pad B
3	29095835	Protection sheet 0.515*650*550
4	29110149	Tape
5	282301	Staple
6	29110141	Tape
7	29053720	Carton box
8	29362820	Label EAN
10	24140456	RC-456S, Remote controller
11	3010054	Battery, UM-3
13	29343066	Instruction manual E
	29343065	Instruction manual CT
14	29100180	Accessory bag

**NOTE:**

<DT> : Asian model only for 120V  
 <PT> : Asian model only for 230V



---

**ONKYO CORPORATION**

Sales & Product Planning Div. : 2-1, Nisshin-cho, Neyagawa-shi, OSAKA 572-8540, JAPAN  
Tel: 072-831-8111 Fax: 072-833-5222

**ONKYO U.S.A. CORPORATION**

18 Park Way, Upper Saddle River, N.J. 07458, U.S.A.  
Tel: 201-785-2600 Fax: 201-785-2650 E-mail: onkyo@onkyousa.com

**ONKYO EUROPE ELECTRONICS GmbH**

Industriestrasse 20, 82110 Germering, GERMANY  
Tel: 089-849-320 Fax: 089-849-3265 E-mail: info@onkyo.de

**ONKYO CHINA LIMITED**

Units 2102-2107, Metroplaza Tower I, 223 Hing Fong Road, Kwai Chung,  
N.T., HONG KONG Tel: 852-2429-3118 Fax: 852-2428-9039