

ONKYO® SERVICE MANUAL**INTEGRATED AMPLIFIER
MODEL A-905X**

Silver model



SUP, SUPT	230V AC, 50Hz
SUD, SUDT	120V AC, 60Hz

SAFETY-RELATED COMPONENT WARNING!!

COMPONENTS IDENTIFIED BY MARK Δ ON THE SCHEMATIC DIAGRAM AND IN THE PARTS LIST ARE CRITICAL FOR RISK OF FIRE AND ELECTRIC SHOCK. REPLACE THESE COMPONENTS WITH ONKYO PARTS WHOSE PARTS NUMBERS APPEAR AS SHOWN IN THIS MANUAL.

MAKE LEAKAGE-CURRENT OR RESISTANCE MEASUREMENTS TO DETERMINE THAT EXPOSED PARTS ARE ACCEPTABLY INSULATED FROM THE SUPPLY CIRCUIT BEFORE RETURNING THE APPLIANCE TO THE CUSTOMER.

TABLE OF CONTENTS

Specifications	1
Service guide	1
Adjustment procedures and confirmation	3
Exploded view	4
Exploded view parts list	5
Microprocessor connection diagram	6
Microprocessor terminal description	7
IC block diagram	8
Printed circuit board parts list	9
PC board view from bottom side	11
Schematic diagram	13
PC board view from bottom side	15
Schematic diagram	17
Index to parts and controls	19
Packing procedures	21
Packing view	22

ONKYO®
AUDIO COMPONENTS

SPECIFICATIONS

Power output

15 watts per channel, min RMS, at 8 ohms, both channels driven 1 kHz, with no more than 0.2% THD
 2 × 20 watts at 4 ohms, 1 kHz (DIN)
 2 × 15 watts at 8 ohms, 1 kHz (DIN)

Total harmonic distortion

0.2% at rated power

IM distortion

0.2% at rated power

Damping factor

30 at 8 ohms

Frequency and response

15 to 30,000 Hz ± 1 dB

Input sensitivity/impedance

TUNER/CD/LINE: 180 mV/50 kohms
 TAPE PLAY: 180 mV/50 kohms
 MD PLAY: 180 mV/50 kohms

Output sensitivity/impedance

TAPE REC: 180 mV/2.2 kohms
 MD REC: 180 mV/2.2 kohms

Bass control

± 8 dB at 50 Hz

Treble control

± 8 dB at 10,000 Hz

Acoustic Presence

1: +3 dB at 20.5 Hz, +3 dB at 82 Hz
 2: +3 dB at 20.5 Hz, +6 dB at 82 Hz

Signal to noise ratio (IHF-A)

CD/TAPE: 100 dB

Muting

-50 dB

General

Power supply

AC 230V, 50Hz
 AC 120V, 60Hz

Dimensions

205 × 91 × 302 mm
 (Width × Height × Depth)

Weight

3.4 kg, 7.5 lbs



Specifications and external appearance are subject to change without notice as a result of product improvement.

SERVICE GUIDE

Replacing the fuses

 This symbol located near the fuse indicates that the fuse used is fast operating type. For continued protection against fire hazard, replace with same type fuse. For fuse rating refer to the marking adjacent to the symbol.

 Ce symbole indique que le fusible utilise est a rapide. Pour une protection permanente, n'utiliser que des fusibles de meme type. Ce dernier est indique la qu le present symbol est appose.

F901	252158		1.6A-UL,T-237, Fuse<D,DT>
	252069		0.8A-SE-EAK, Fuse<P,PT>
F902~F904	252075		2.5A-SE-EAK, Fuse<P,PT>

NOTE : <D,DT> 120V model only
 <P,PT> 230V model only

ADJUSTMENT PROCEDURES AND CONFIRMATION

1. Idling current adjustment

Before Idling adjustment, turn the trimming resistors R575, R576, to counter clockwise.

Connect the DC voltmeter to terminal P503,P504.

After turn POWER to ON, adjust the trimming resistors R575,R576 so that the reading of voltmeter becomes 2.0 mV.

After adjustment, attach the top cover.

Confirm the voltage of above points after five minutes.

Readjust to 3mV when less than 2.5 mV.

Don't adjust when 2.5 mV to 4mV.

Readjust to 3.5 mV when more than 4 mV

Note: No load and No signal

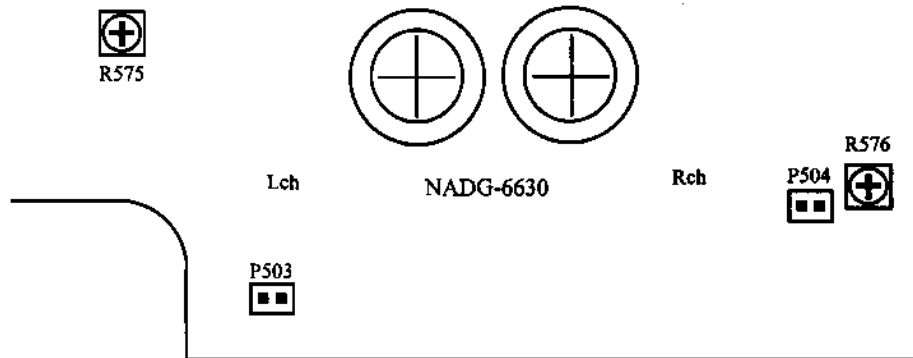

Confirmation of protection circuit

1. Confirmation of Current detection circuit

Connect Differentiator and apply the 50Hz square signal to the CD terminal .

Adjust the attenuator or Volume so that the output level becomes 35V p-p.

Confirm that the speaker relay turns OFF when a 0.5 ohm load is connected.

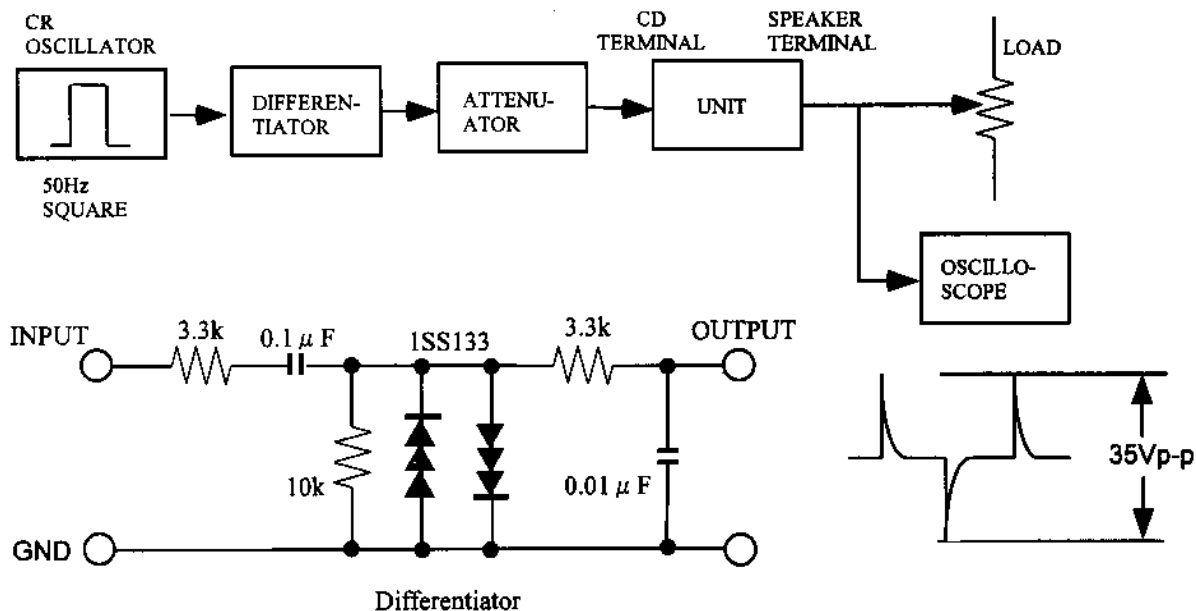

EXPLODED VIEW

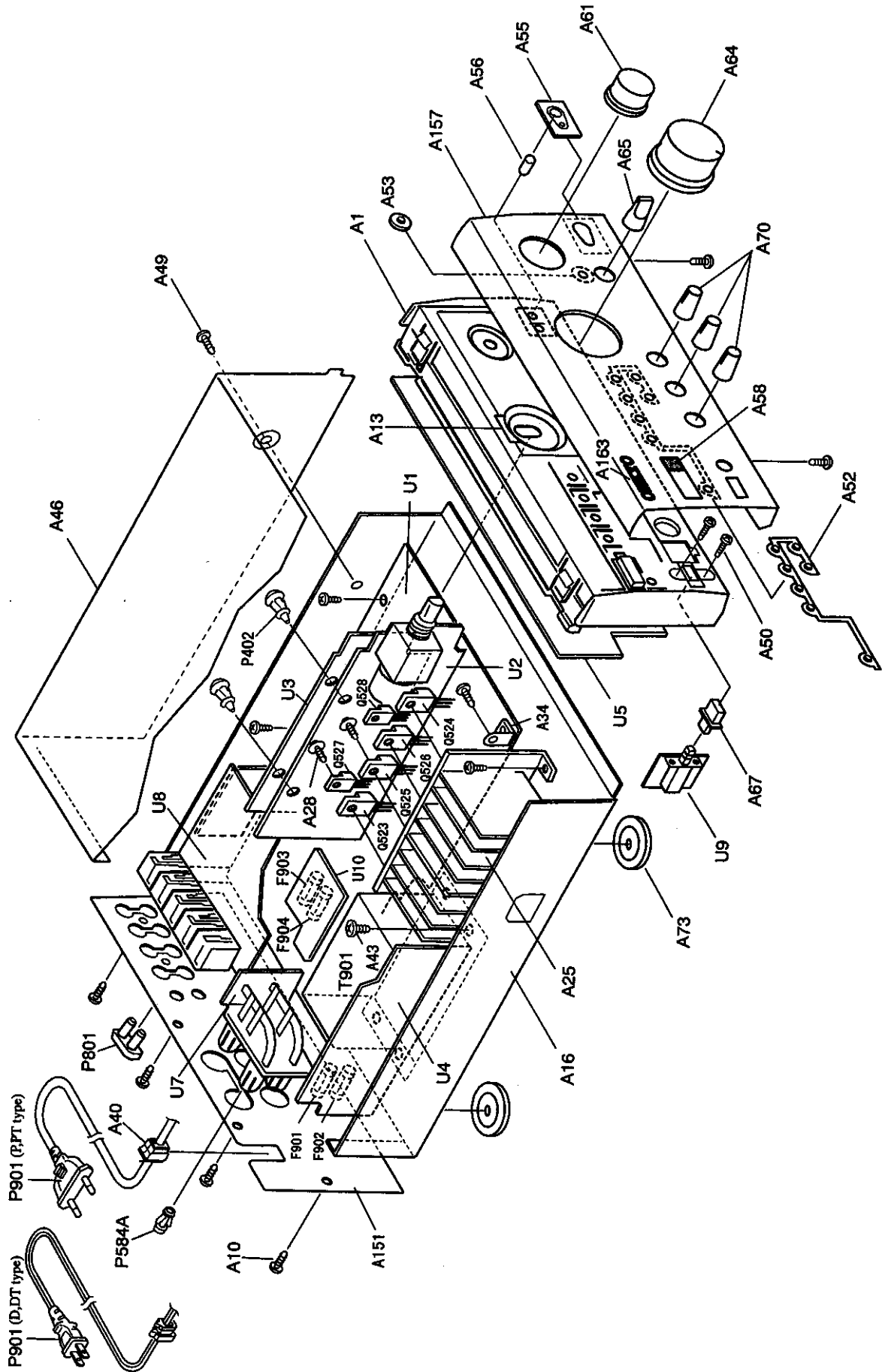

EXPLODED VIEW PARTS LIST

REF. NO.	PART NO.	DESCRIPTION	REF. NO.	PART NO.	DESCRIPTION
A1	27111123	Front bracket	P901	253277MIL	AS-UC-2#18, Power supply cord <D, DT>
A10	838130088	3TTB+8B, Self tapping screw	Q523, Q524	253193HIT	AS-CEE, Power supply cord <P, PT>
A13	28198862	Facet		2202303 or	2SC4512-O or
A16	27100375A	Chassis		2202304 or	2SC4512-Y or
A25	27160451	Heatsink <D/DT>	Q525, Q526	2202305	2SC4512-P, Transistor
A28	27160452	Heatsink <P/PT>		2202313 or	2SA1726-O or
A34	801433	3SMS8W.SW+14B(BC), Special screw		2202314 or	2SA1726-Y or
A40	27300750	Retainer	Q527, Q528	2212654 or	2SA1726-P, Transistor
A43	830440089	Bushing, cord		2212653	2SC3421-Y or
A46	28184759	4TTC+8C(BC), Self tapping screw	T901	2301423	2SC3421-O, Transistor
A49	838930088	Top cover	U1	2301424	NFT-1374D, Power transformer <D/DT>
A50	838430107	3TTB+8B(UN), Self tapping screw		1A847530-1B	NFT-1374P, Power transformer <P/PT>
A52	28198894	3TTB+10S(BC), Self tapping screw	U2	1A847530-1C	NADG-6630-1B, Main circuit PC board assy <D/DT>
A53	28198895	Facet (7P)		1A847531-1B	NADG-6630-1C, Main circuit PC board assy <P/PT>
A55	28191797	Clear plate, AP	U3	1A847531-1C	NAAF-6631-1B, Volume circuit PC board assy <D/DT>
A56	28325133	Knob, FM		1A847532-1B	NAAF-6631-1C, Volume circuit PC board assy <P/PT>
A58	28191798	Clear plate, RE	U4	1A847532-1C	NAAF-6632-1B, Acoustic circuit PC board assy <D/DT>
A61	28325672A	Knob INP		1A847532-1C	NAAF-6632-1C, Acoustic circuit PC board assy <P/PT>
A64	28325670	Knob VOL	U5	1A847533-1B	NAPS-6633-1B, Power supply circuit PC board assy <D/DT>
A65	28325674	Knob ID		1A847533-1C	NAPS-6633-1C, Power supply circuit PC board assy <P/PT>
A67	28325673	Knob POWER	U6	1A847534-1B	NADIS-6634-1B, Display circuit PC board assy <D/DT>
A70	28325695	Knob TONE		1A847534-1C	NADIS-6634-1C, Display circuit PC board assy <P/PT>
A73	27175323	Leg	U7	1A847534-1C	NAETC-6636-1B, Speaker terminal PC board assy <D/DT>
A151	27122600	Rear panel <D>		1A847536-1C	NAETC-6636-1C, Speaker terminal PC board assy <P/PT>
A157	27122601	Rear panel <P/PT>	U8	1A847537-1B	NAETC-6637-1B, Terminal PC board assy <D/DT>
A163	27122614	Rear panel <DT>		1A847537-1C	NAETC-6637-1C, Terminal PC board assy <P/PT>
A169	27212109	Front panel	U9	1A847539-1B	NAETC-6639-1B, Power switch PC board assy <D/DT>
E860	28135247Y	Badge		1A847539-1C	NAETC-6639-1C, Power switch PC board assy <P/PT>
F901	801525	3TTB+8B(BC), Self tapping screw <P>	U10	1A847540-1C	NAETC-6640-1C, Fuse PC board assy <P/PT>
F902	260208	Wire tie			
F903	252158	1.6A-UL, T-237, Fuse <D, DT>			
F904	252069	0.8A-SE-EAK, Fuse <P, PT>			
F905	252075	2.5A-SE-EAK, Fuse <P, PT>			
F906	27190011	KGLS-6S, Holder			
F907	880009	Plastic rivet <P/PT>			
F908	27190608-1	UA-00 V0, Holder			
F909	25055436 or	NPLG-2P418 or			
F910	25055945	NPLG-2P898, Plug			

CAUTION : Replacement of the transistor of mark * if necessary, must be made from the same beta group(HFE) as the original type.

NOTE : THE COMPONENTS IDENTIFIED BY MARK **A** ARE CRITICAL FOR RISK OF FIRE AND ELECTRIC SHOCK. REPLACE ONLY WITH PART NUMBER SPECIFIED.

NOTE : <D,DT> : 120V model only
<P,PT> : 230V model only

MICROPROCESSOR CONNECTION DIAGRAM

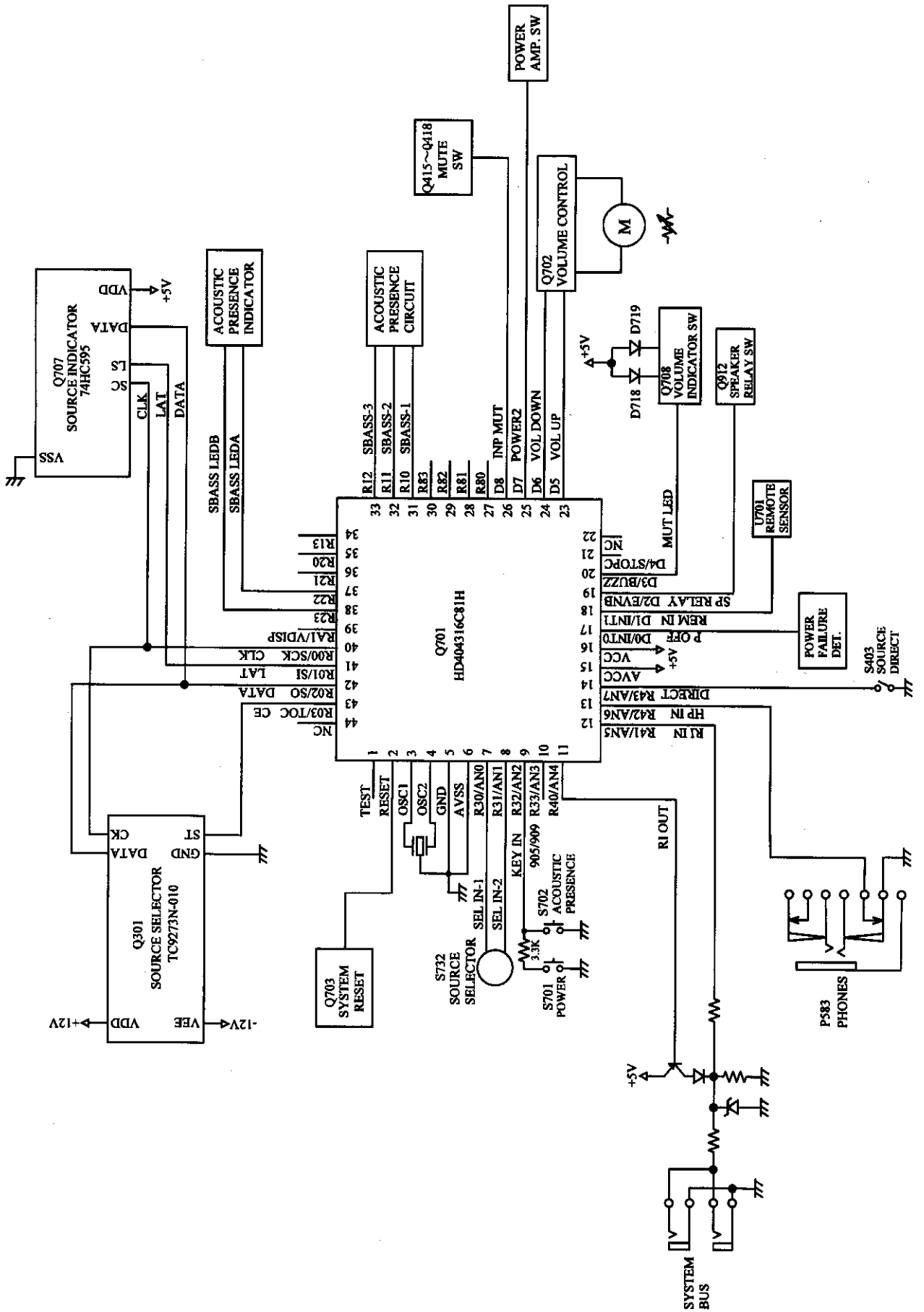

MICROPROCESSOR TERMINAL DESCRIPTION

Pin No.	Mark	Function	Descriptions
1	TEST	TEST	Test pin
2	RESET	RESET	System reset input pin
3	OSC1	OSC1	Pins to connect the ceramic oscillator 4.0MHz.
4	OSC2	OSC2	
5	GND	GND	Ground pin
6	AVSS	AVSS	Analog reference ground for A/D converter
7	R30/AN0	SEL IN-1	Input selector rotary switch input pin
8	R31/AN1	SEL IN-2	Input selector rotary switch input pin
9	R32/AN2	KEY IN	Operation key connection pin
10	R33/AN3	905/909	Initializing input pin for model selector
11	R40/AN4	RI OUT	System code output pin
12	R41/AN5	RI IN	System code input pin
13	R42/AN6	HP IN	Head phone switch position detector pin.
14	R43/AN7	DIRECT	Direct switch position detector pin.
15	AVCC	AVCC	Analog reference voltage for A/D converter
16	VCC	VCC	Power supply pin (+5V)
17	D0/INT0	POFF	Power failure detector pin
18	D1/INT1	REM IN	Remote control signal input pin
19	D2/EVNB	NC	Speaker relay control signal output pin
20	D3/BUZZ	MUT LED	MUTING indicator control pin. Light on and off when the muting circuit turns on.
21	D4/STOPC	NC	No connection
22	NC	NC	No connection
23	D5	VOL UP	Volume control output pin
24	D6	VOL DOWN	Volume control output pin
25	D7	POWER 2	Power amplifier control output pin
26	D8	INPMUT	Muting control output pin
27	R80	NC	Connect to the ground.
28	R81	NC	Connect to the ground.
29	R82	NC	Connect to the ground.
30	R83	NC	Connect to the ground.
31	R10	SBASS-1	Acoustic Presence control output pin
32	R11	SBASS-2	Acoustic Presence control output pin
33	R12	SBASS-3	Acoustic Presence control output pin
34	R13	NC	Connect to the ground.
35	R20	NC	Connect to the ground.
36	R21	PROTECT	Speaker protect signal detector pin
37	R22	SBASS LEDA	Acoustic Presence indicator output pin
38	R23	SBASS LEDB	Acoustic Presence indicator output pin
39	RA1/VD	NC	Connect to the ground.
40	R00/SC	CLK	Clock output pin of source selector and indicator ICs.
41	R01/SI	LAT	Latch output pin of source indicator IC.
42	R02/SO	DATA	Data output pin of source selector and indicator ICs.
43	R03/SO	CE	Chip enable output pin of source selector IC.
44	NC	NC	No connection

PRINTED CIRCUIT BOARD PARTS LIST

MAIN CIRCUIT PC BOARD (NADG-6630-1B/1C)

CIRCUIT NO.	PART NO.	DESCRIPTION
Q301	22240881	TC9273N-010
Q701	22241367	HD404316E04H
Q702	22240239	TA7291S
Q713	222951	M51943B
Q911	222780565JRC	78M56(NJM78M56FA)
Transistors		
Q451	2213510 or 2215770	DTA114ES or NSP KRA102M
Q515,Q516	2211733 or 2211732	2SC1845-E or 2SC1845-F
Q517,Q518,Q533	2211793 or 2211792	2SA992-E or 2SA992-F
Q519,Q520	2211643 or 2211644	2SA965-O or 2SA965-Y or
Q521,Q522	2211653 or 2211654	2SC2235-O or 2SC2235-Y
Q529,Q530,Q705	2213284	2SC1740S-R
Q531,Q532	2211733 or 2211732	2SC1845-E or 2SC1845-F
Q703,Q714	221282 or 2215820	DTC144ES or NSP KRC104M
Q704	2212600 or 2215780	DTA124ES or NSP KRA103M
Q706	2213354	2SA933S-R
Q912	2213640	DTC123JS
Diodes		
D701	223163 or 223205	1SS133 or 1SS270A
D702	22380035 or 22380046	GP104003E or AM01Z
D703,D704	223163 or 223205	1SS133 or 1SS270A
D705	224470562	MTZJ5.6B
D706	223163 or 223205	1SS133 or 1SS270A
D707	224470512	MTZJ5.1B
D708,D722	223163 or 223205	1SS133 or 1SS270A
D745	224470512	MTZJ5.1B
D911	22380022F or 22380271F	RBV402 or D3SBA20
D912,D913	224471203	MTZJ12C
D914-D918	22380035 or 22380046 or 22380035	GP104003E or AM01Z or GP104003E
D919	223163 or 223205	1SS133 or 1SS270A
Coils		
L501,D702	231176S	S-1.3C
L503-L506	5597-45502	FR Core
Relay		
RL901	25065579	▲ NRL-2P5A-DC12-136
Oscillator		
X701	3010150	CST4.00MGW
Capacitors		
C321,C322,C922	393341007	10 μ F,16V,Elect.
C451,C452	353780229	2.2 μ F,50V,Elect.
C515,C516	393381007	10 μ F,50V,Elect.
C517,C518	374724734	0.047 μ F \pm 5%,50V,Plastic
C701	3000076 or 3000078	EECS5R5T104 or DX-5R5L104
C702	375524744	0.47 μ F \pm 5%,50V,Plastic
C703,C916,C917	354721019	100 μ F,6.3V,Elect.
C708	354780229	2.2 μ F,50V,Elect.
C711	354780109	1 μ F,50V,Elect.
C712,C912,C913	374721044	0.1 μ F \pm 5%,50V,Plastic
C914,C915	3504317	3300 μ F,35V,Elect.
C918	374721034	0.01 μ F \pm 5%,50V,Plastic
C919	354744709	47 μ F,16V,Elect.
C920	354742229S	2200 μ F,16V,Elect.

CIRCUIT NO.	PART NO.	DESCRIPTION
R543	443521014	100 Ω \pm 5%,1/2W,Metal oxide
R544-R547	443521014	100 Ω \pm 5%,1/2W,Metal oxide
R547-R550	443521504	15 Ω \pm 5%,1/2W,Metal oxide
R551-R554	453530224	2.2 Ω \pm 5%,1/2W,Metal oxide
R555,R556	443528204	82 Ω \pm 5%,1/2W,Metal oxide
R557-R560	443521004	10 Ω \pm 5%,1/2W,Metal oxide
R561,R562	4500027	MPC708-2WK-0.22,Metal plate
R563,R564	453530474	4.7 Ω \pm 5%,1/2W,Metal oxide
R565,R566	453530824	8.2 Ω \pm 5%,1/2W,Metal oxide
R575,R576	5210257	N06HR500BC, Trimming resistor
R593-R596	443521004	10 Ω \pm 5%,1/2W,Metal oxide
R912,R914	443522714	270 Ω \pm 5%,1/2W,Metal oxide
R913,R915	443522214	220 Ω \pm 5%,1/2W,Metal oxide
R917	443521004	10 Ω \pm 5%,1/2W,Metal oxide
Sockets		
JL581a	25051088	NSCT-4P875
JL901b	25051107	NSCT-3P894
P405	2009990565UL	NSAS-14P0758
P910	25051637	▲ NSCT-2P1424 <P,PT>
P910	25051990	▲ NSCT-2P1777 <D,DT>
Plugs		
JL582b	25055624	NPLG-3P586
JL701b	25055630	NPLG-9P592
JL702b	25055628	NPLG-7P590
P311a	25055709	NPLG-13P665
P401a	25055706	NPLG-10P662
P403a,P502a	25055702	NPLG-6P658
P461B	25055133	NPLG-3P117
P501a	25055808	NPLG-19P764
P503	25055038	NPLG-2P29
P504	25055038	NPLG-2P29
Terminals		
P301-P303	25045303	NPJ-4PDBL162, Terminal
P582	25045302	NPJ-1PDBL161, Terminal
Fuse Holder		
F902	25050065	YSH403T <P,PT>
Retainer		
E851	27141749	(BUS)
Label		
F901C	29362519	T800mAL250V <P,PT>

VOLUME CIRCUIT PC BOARD (NAAF-6631-1B/1C)

CIRCUIT NO.	PART NO.	DESCRIPTION
Transistors		
Q501-Q504	2211732 or 2211733	2SC1845-F or 2SC1845-E
Q505,Q506	2213284	2SC1740S-R
Q507-Q512	2211792 or 2211793	2SA992-F or 2SA992-E
Q513,Q514	2211732 or 2211733	2SC1845-F or 2SC1845-E
Diodes		
D501,D502	223163 or 223205	1SS133 or 1SS270A
D503,D504	224470562	MTZJ5.6B

CIRCUIT NO.	PART NO.	DESCRIPTION
	Capacitors	
C501,C502	393382207	22 μ F,50V,Elect.
C503,C504	374721015	100pF \pm 5%,50V,Plastic
C509,C510	393322217	220 μ F,6.3V,Elect.
C511,C512	354741009	10 μ F,16V,Elect.
C513,C514	393381007	10 μ F,50V,Elect.
C519-C520	393381017	100 μ F,50V,Elect.
	Resistors	
R458	5104383	N16RGL100KBT20F,Volume
R523,R524	443528214	820 Ω \pm 5%,1/2W,Metal oxide
R525-R528	443528214	820 Ω \pm 5%,1/2W,Metal oxide
R529,R530	443521224	1.2k Ω \pm 5%,1/2W,Metal oxide
R597,R598	443521224	1.2k Ω \pm 5%,1/2W,Metal oxide
	Plug	
P405A	25055137	NPLG-7P121
	Sockets	
P501b	25051530	NSCT-19P1317
P502b	25051231	NSCT-6P1021

ACOUSTIC CIRCUIT PC BOARD(NAAF-6632-1B/1C)

CIRCUIT NO.	PART NO.	DESCRIPTION
	ICs	
Q401	22240191	NJM4565D-D
Q402,Q403	22240250	NJM2068L-D
Q404	222956	NJM2068D-D
	Transistors	
Q405-Q412	2211945	2SK246-GR
Q415-Q418	2213631 or 2213632	RN1241-A or RN1241-B
	Diodes	
D401-D408	223163 or 223205	1SS133 or 1SS270A
	Capacitors	
C403 ,C404	393384707	47 μ F,50V,Elect.
C405,C406	374721024	1000pF \pm 5%,50V,Plastic
C407,C408	393384707	47 μ F,50V,Elect.
C409,C410	374721044	0.1 μ F \pm 5%,50V,Plastic
C411,C412	393380227	2.2 μ F,50V,Elect.
C413,C414	374722244	0.22 μ F \pm 5%,50V,Plastic
C415,C416	374723934	0.039 μ F \pm 5%,50V,Plastic
C417,C418	374724744	0.47 μ F \pm 5%,50V,Plastic
C419,C420	374721044	0.1 μ F \pm 5%,50V,Plastic
C421,C422	374728224	8500pF \pm 5%,50V,Plastic
C425,C426	393341007	10 μ F,16V,Elect.
C427,C428	374721534	0.015 μ F \pm 5%,50V,Plastic
C429,C430	393341007	10 μ F,16V,Elect.
	Sockets	
P401b	25051235	NSCT-10P1025
P403b	25051231	NSCT-6P1021
	Plug	
JL501b	25055629	NPLG-8P591

POWER SUPPLY PC BOARD(NAPS-6633-1B/1C)

CIRCUIT NO.	PART NO.	DESCRIPTION
	Resistor	
R916	453534794	0.47 Ω \pm 5%,1/2W,Metal oxide
	Socket	
JL901a	25051107	NSCT-3P894, Socket
	Plug	
P901a	25055676	▲ NPLG-2P632, Plug
	Fuse holder	
F901	25050065	▲ YSH403T

DISPLAY CIRCUIT PC BOARD(NADIS-6634-1B/1C)

CIRCUIT NO.	PART NO.	DESCRIPTION
	Remote sensor	
U701	241307	GP1U271X
	Transistors	
Q413,Q414	2211945	2SK246-GR
Q707	222745955	74HC595P
Q708	2213290 or 2215960	DTC114ES or KRC102M
Q709,Q710	2213160 or 2215810	DTC124ES or KRC103M
Q711,Q712	2213510 or 2215770	DTA114ES or KRA102M

CIRCUIT NO.	PART NO.	DESCRIPTION
	Diodes	
D409,D410	223163 or 223205	1SS133 or 1SS270A
D709,D710,D746	223163 or 223205	1SS133 or 1SS270A
D711,D721	225338	SLR-332VR
D712-D717	225340	SLR-332DU
D718,D719	225142DY1 or 225142DR1	SEL2913K-DY1 or SEL2913K-DR1
D720	225339	SPR-39MVWF
	Capacitors	
C423,C424	374721534	0.015 μ F \pm 5%,50V,Plastic
C714,C715	353741009	10 μ F,16V,Elect.
C717,C718	353741009	10 μ F,16V,Elect.
C746	353721019	100 μ F,6.3V,Elect.
	Resistors	
R437,R438	5104341	N14RHC100KWT20Z,tone control
R461	5104407	N12RGLC250KWT20,Balance
	Rotary encoder	
R732	25065534	REB161PVB, Rotary encoder
	Terminals	
P583	25045396	LGT1516-0101, Headphone jack
	Switches	
S401	25030415	NRSF-122-15SRB, Rotary switch
S701,S702	25035652	NPS-111-S604, push switch
	Sockets	
P461A	2009990296	NSAS-6P0429
JL582a	25051087	NSCT-3P874
JL702a	25051091	NSCT-7P878
JL501a	25051092	NSCT-8P879
JL701a	25051093	NSCT-9P880
	Holder	
D718a	27191018	(LED),Holder

SPEAKER TERMINAL PC BOARD (NAETC-6636-1B/1C)

CIRCUIT NO.	PART NO.	DESCRIPTION
P584	25060193	NTM-4PDMN115
JL581c	25051088	NSCT-4P875

TERMINAL PC BOARD NAETC-6637-1B/1C)

CIRCUIT NO.	PART NO.	DESCRIPTION
	Capacitors	
C319,C320	374721015	100pF \pm 5%,50V,Plastic <P,PT>
	Terminals	
P304,C305	25045303	NPJ-4PDBL162, Terminal
P306	25045330	NPJ-2PDBL184, Terminal
	Socket	
P311b	25051238	NSCT-13P1028

POWER SWITCH PC BOARD(NAETC-6639-1B/1C)

CIRCUIT NO.	PART NO.	DESCRIPTION
	Capacitor	
C951	3500191	▲ DE7150F-103M
	Cover	
C951a	27301216	▲ SB1925A <P,PT>
	Switch	
S951	25035550	▲ NPS-111-L512P, power switch

FUSE PC BOARD (NAETC-6640-1C)

CIRCUIT NO.	PART NO.	DESCRIPTION
F902-F904	25050065	▲ YSH403T <P,PT>

NOTE: THE COMPONENTS IDENTIFIED BY MARK ▲ ARE CRITICAL FOR RISK OF FIRE AND ELECTRIC SHOCK. REPLACE ONLY WITH PART NUMBER SPECIFIED.

NOTE: <DDT>:120V model only
<P,PT>:230V model only

NSP : No spare parts

SCHEMATIC DIAGRAM

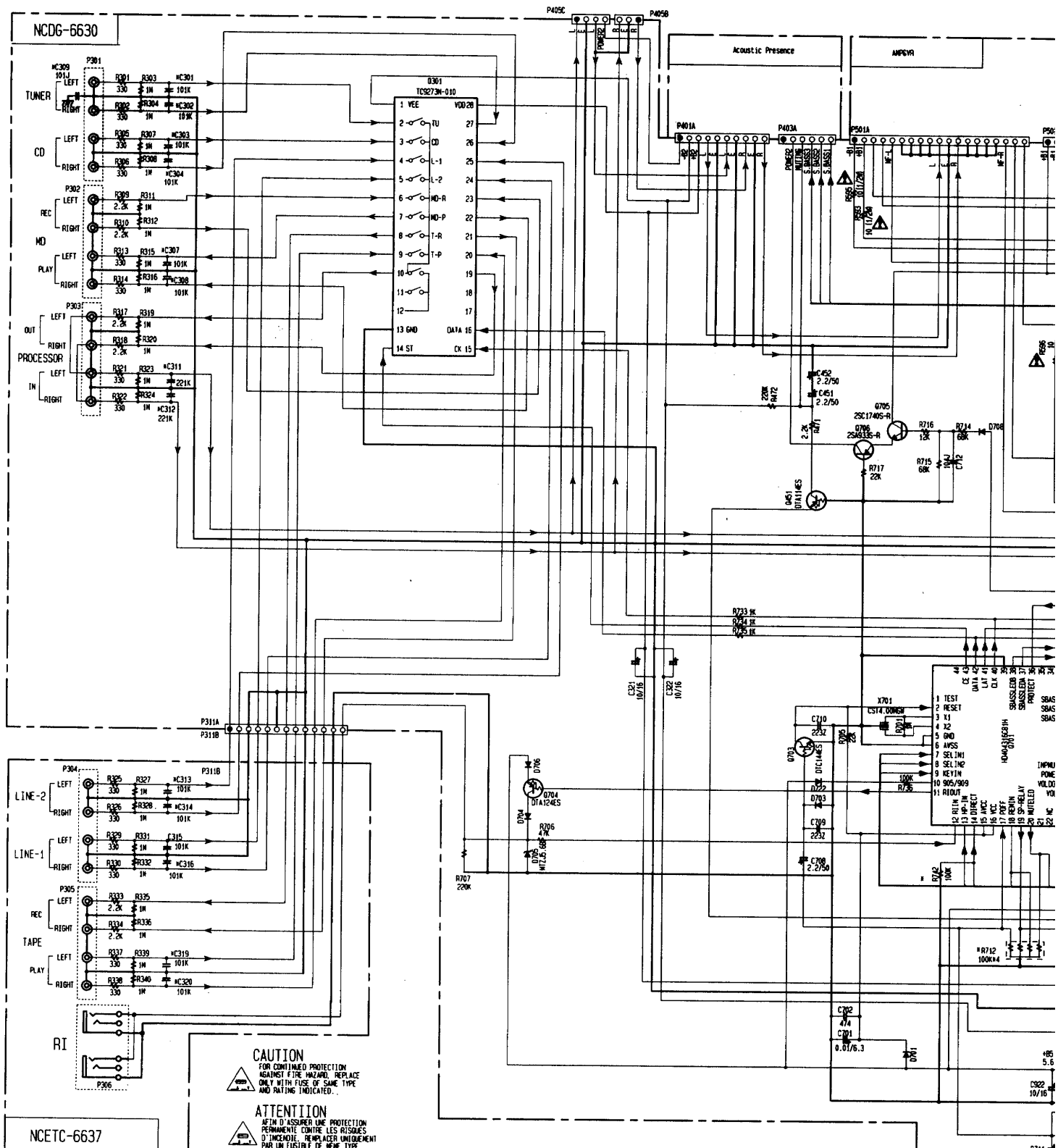

CAUTION
 FOR CONTINUED PROTECTION
 AGAINST FIRE HAZARD, REPLACE
 ONLY WITH FUSE OF SAME TYPE
 AND RATING INDICATED.

ATTENTION
 AFIN D'ASSURER UNE PROTECTION
 PERMANENTE CONTRE LES RISQUES
 D'INCENDIE, REMPLACEZ UNIQUEMENT
 PAR UN FUSIBLE DE MÊME TYPE
 ET CALIBRATION COMME INDICÉ.

PARTS NUMBER	USE
C301-C304, C307, C308	NO USE
C311-C316, C319, C320	NO USE
C581, C582	NO USE
R712, R713, R718, R719	ONE TIME ONLY
R742	ONE TIME ONLY

THIS SYMBOL, LOCATED NEAR THE FUSE INDICATES THAT THE FUSE USED IS SLOW OPERATING TYPE. FOR CONTINUED PROTECTION AGAINST FIRE HAZARD, REPLACE WITH SAME TYPE FUSE. FOR FUSE RATINGS REFER TO THE MARKING ADJACENT TO THE SYMBOL.

CE SYMBOLE INDIQUE QUE LE FUSIBLE UTILISÉ EST À LENT, É POUR UNE PROTECTION PERMANENTE. UTILISER QUE DES FUSIBLES DE MÊME TYPE. CE D'AVERTIR EST INDICÉ LA OÙ LE PRÉSENT SYMBOLE EST APPRÉ.

NOTE

- THE COMPONENTS IDENTIFIED BY MARK ARE CRITICAL FOR SAFETY. REPLACE ONLY WITH PART NUMBER SPECIFIED.
- VOLTAGE MEASURED WITH VOLTMETER. IS DC VOLTAGE, (NO INPUT SIGNAL).
- ALL PNP TRANSISTORS ARE EQUIVALENT TO 2SA1015-GR UNLESS OTHERWISE NOTED.
- ALL NPN TRANSISTORS ARE EQUIVALENT TO 2SC1815-GR UNLESS OTHERWISE NOTED.
- ALL DIODES ARE EQUIVALENT TO 1S5333 UNLESS OTHERWISE NOTED.
- ELECTROLYTIC CAPACITORS ARE 10% TOLERANCE UNLESS OTHERWISE NOTED.
- ALL CAPACITORS ARE IN pF/50V UNLESS OTHERWISE NOTED.
- EX) 030-04F 330-030F 331-030F 333-0.033F
- ALL RESISTORS ARE IN OHMS /WATTS UNLESS OTHERWISE NOTED.
- THE THICK LINES ON PC BOARD ARE THE PRINTING SIDE OF THE PARTS.
- EX) PRINTING SIDE.
- CIRCUIT IS SUBJECT TO CHANGE FOR IMPROVEMENT.

E

F

G

H

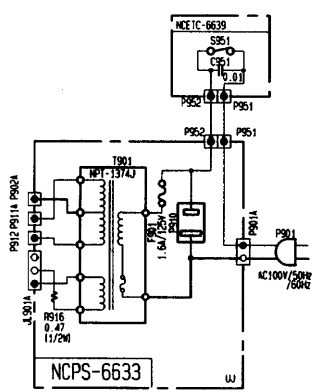
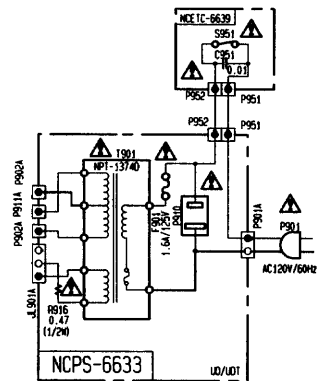
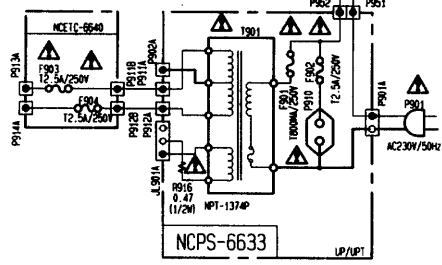
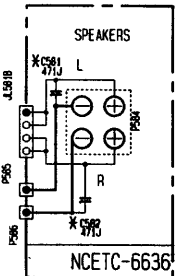
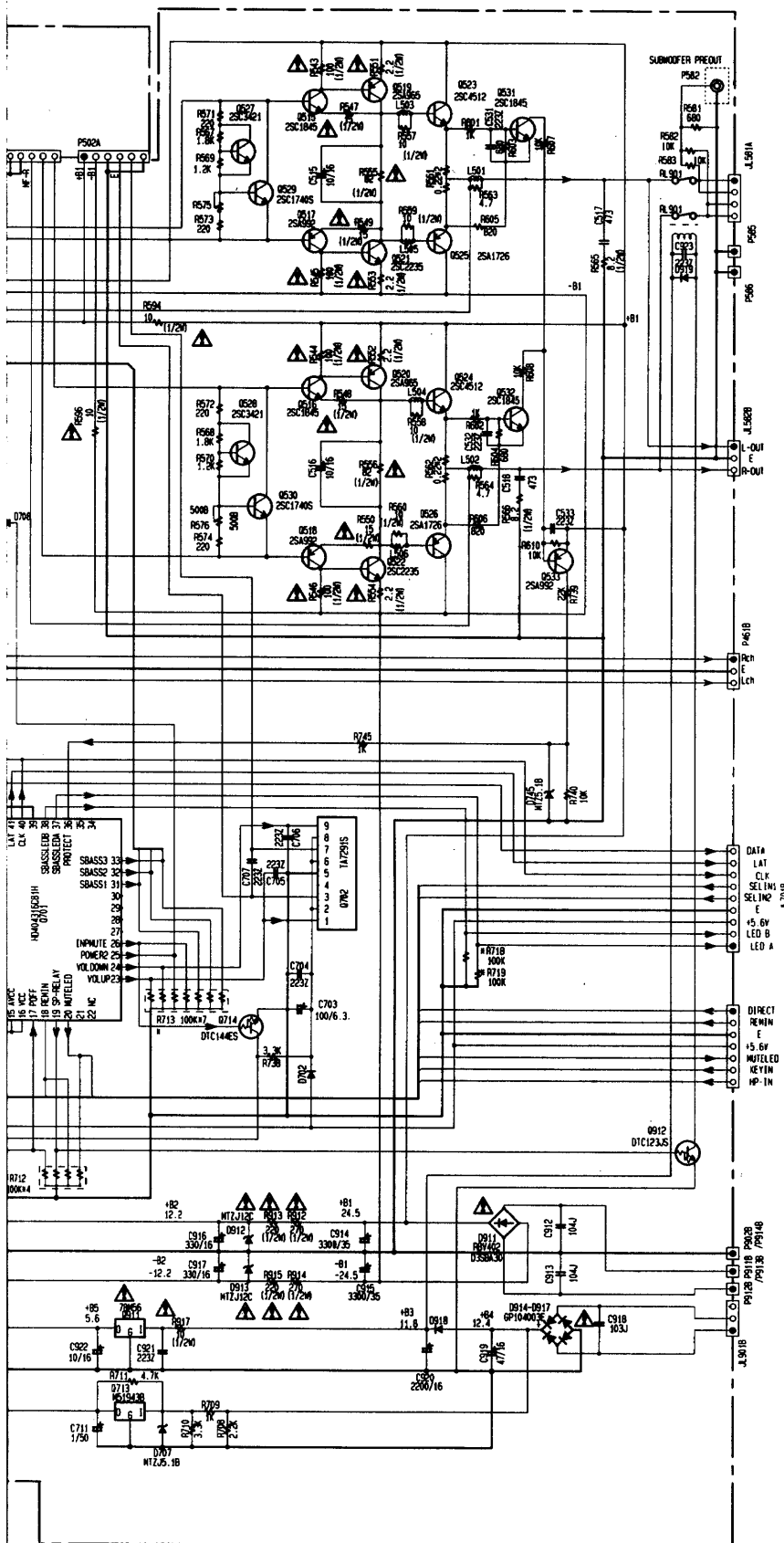

SCHEMATIC DIAGRAM

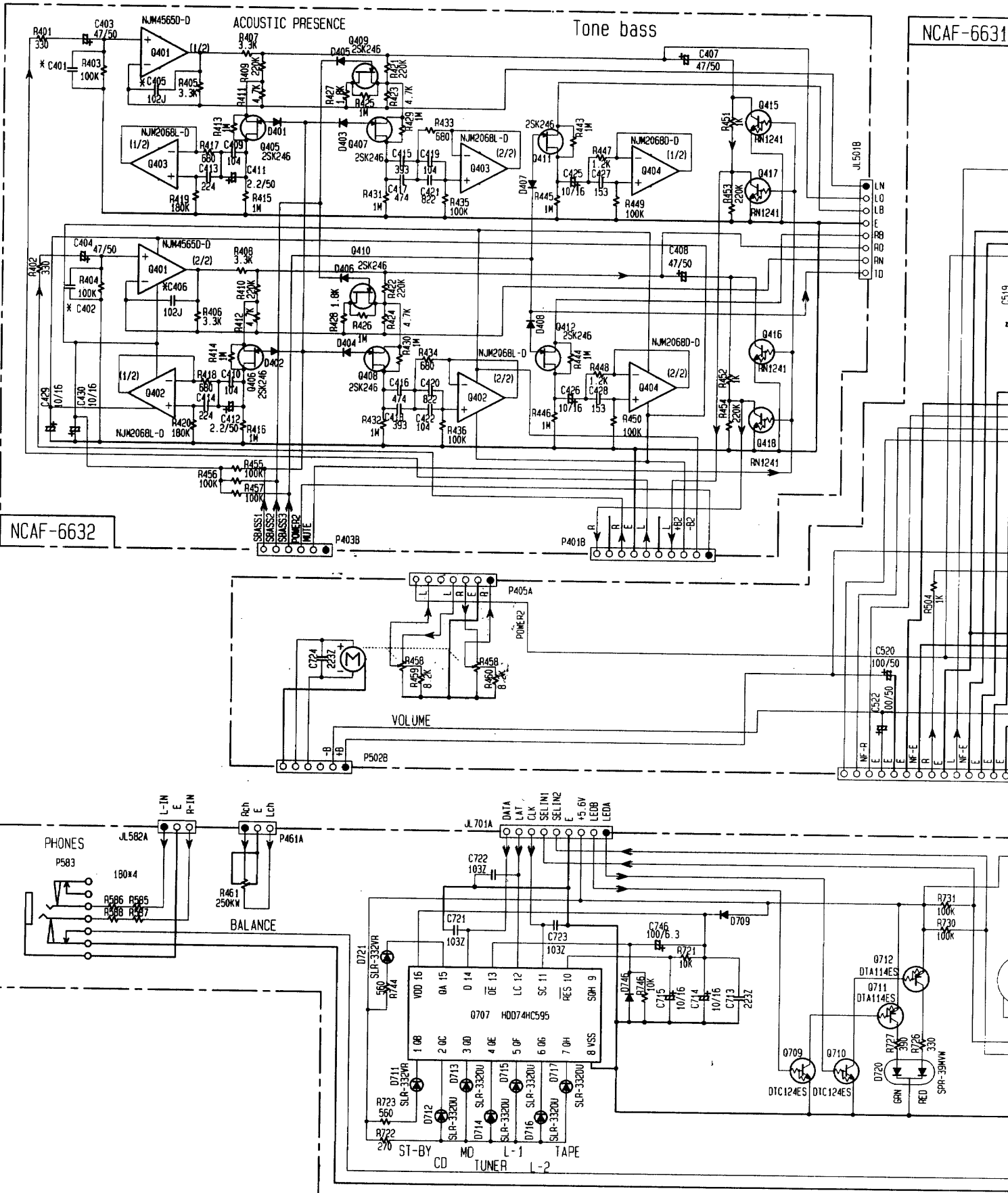

E F G H

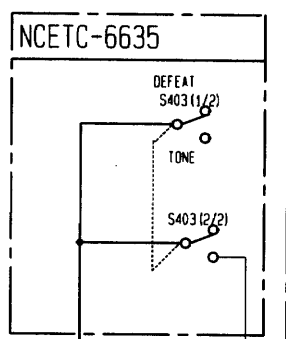
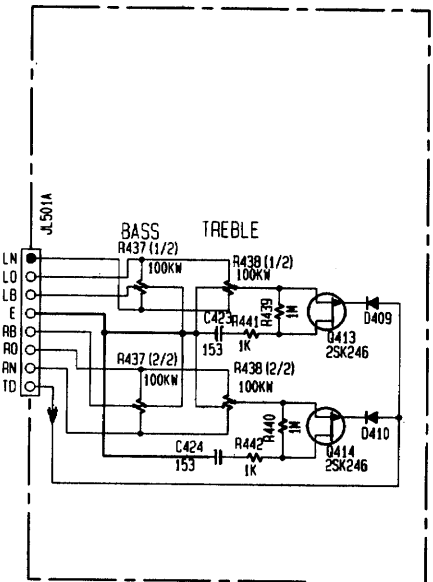
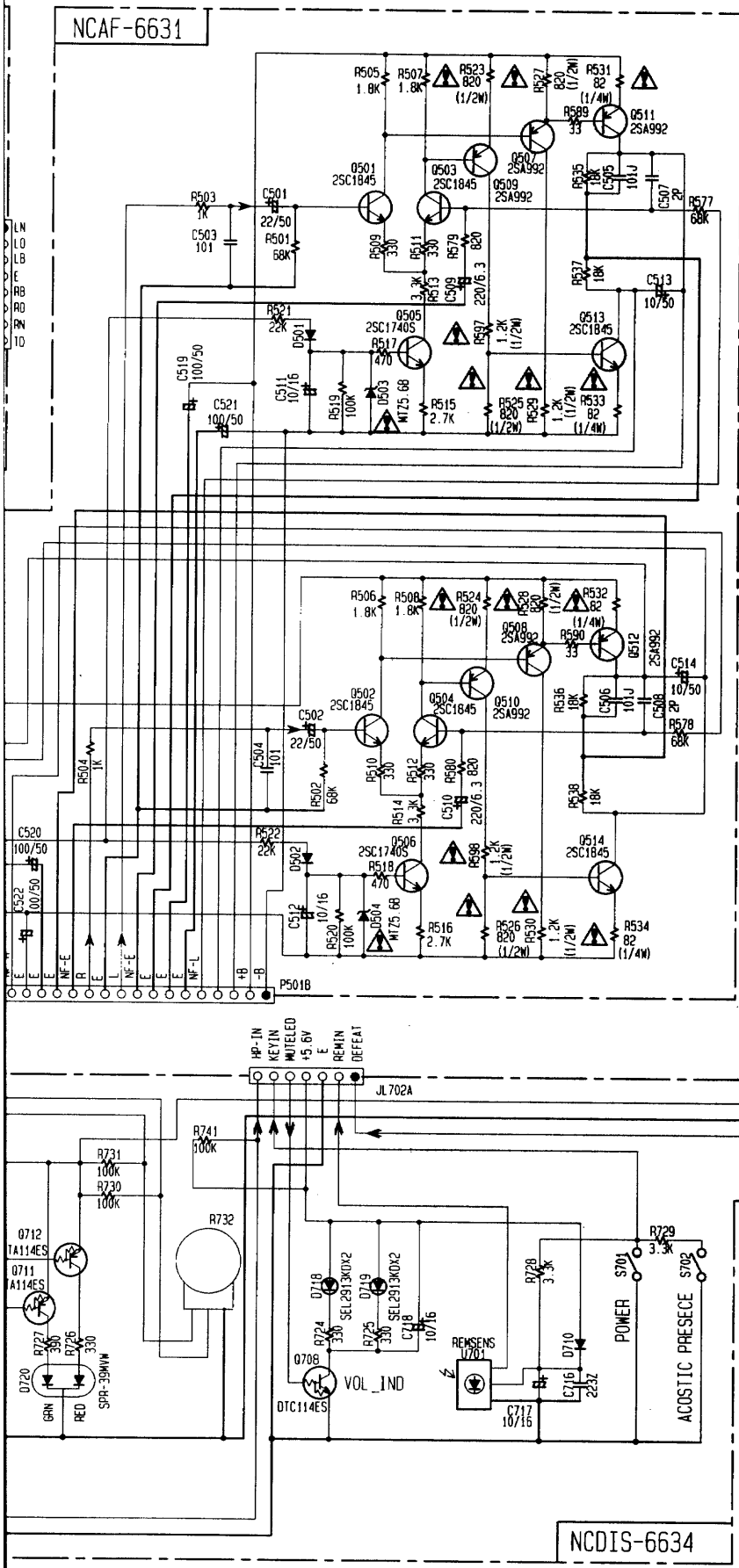

NOTE

- THE COMPONENTS IDENTIFIED BY MARK Δ ARE CRITICAL FOR SAFETY. REPLACE ONLY WITH PART NUMBER SPECIFIED.
- VOLTAGE (MEASURED WITH VOLTMETER) \square IS DC VOLTAGE. (NO INPUT SIGNAL)
- ALL PNP TRANSISTORS ARE EQUIVALENT TO 2SA1015-GR UNLESS OTHERWISE NOTED.
- ALL NPN TRANSISTORS ARE EQUIVALENT TO 2SC1815-GR UNLESS OTHERWISE NOTED.
- ALL DIODES ARE EQUIVALENT TO 1SS133 UNLESS OTHERWISE NOTED.
- ELECTROLYTIC CAPACITORS (\square) ARE IN μ F/V.
- ALL CAPACITORS ARE IN pF/50WV UNLESS OTHERWISE NOTED.
- EX) 030-30F 330-30pF 331-830pF 333-0.033uF
- ALL RESISTORS ARE IN OHMS 1/4WATTS UNLESS OTHERWISE NOTED.
- THE THICK LINES ON PC BOARD ARE THE PRINTING SIDE OF THE PARTS
- EX) \square PRINTING SIDE
- CIRCUIT IS SUBJECT TO CHANGE FOR IMPROVEMENT.

PACKING VIEW

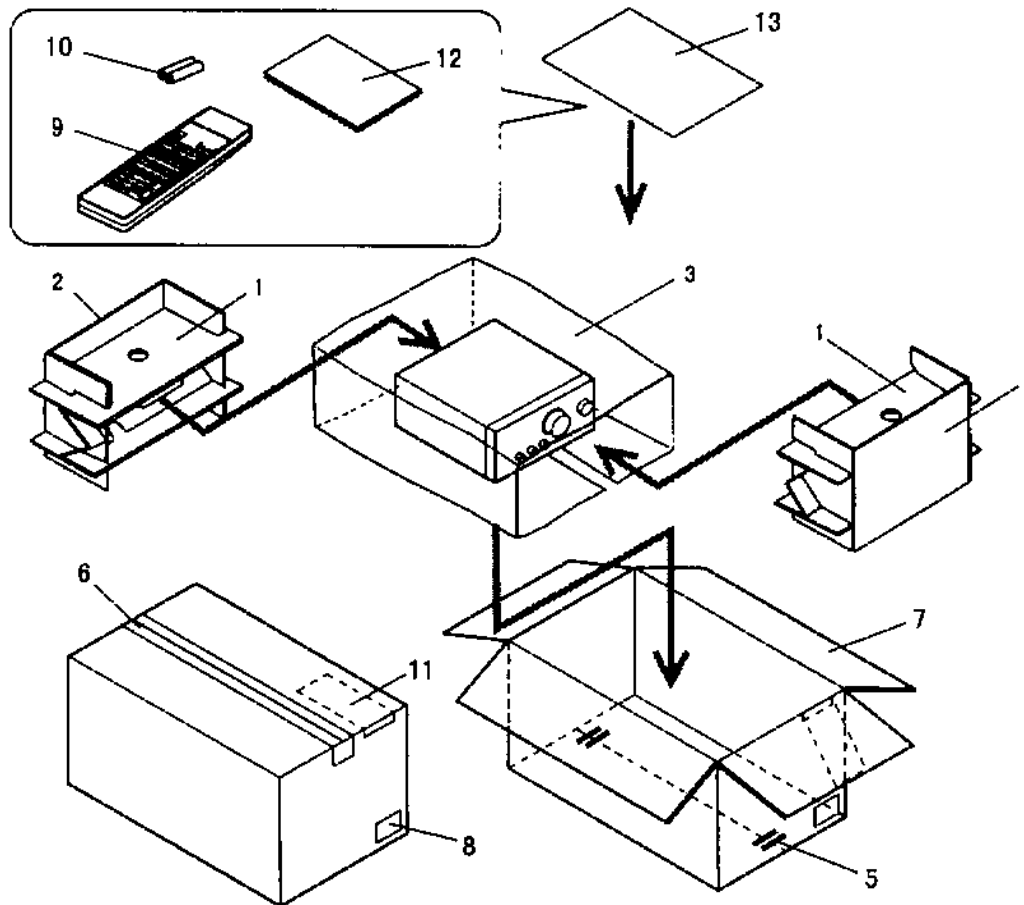

PARTS LIST

REF.NO.	PART NO.	DESCRIPTION	REF.NO.	PART NO.	DESCRIPTION
1	29091886	Pad A	12	29342717	Instruction manual E
2	29091887	Pad B	12	29342718	Instruction manual U3/ FSI
3	29095835	Protection sheet	12	29342719	Instruction manual U3/
4	261504	Paper tape	12	29342720	Instruction manual T/ <PT/
5	282301	Staple	12	29095745A	Instruction sheet <P/ PT>
6	29110071	PP tape	12	29095866	Sheet ONKYO <D>
7	29053453	Carton box	12	29355133A	Instruction sheet DBP
8	29362468	Label UPC <D>	13	29100180	Accessory bag
8	29362471	Label EAN <P/PT/DT>			
9	24140398A	RC-398S			
10	3010054	Battery			
11	29365083	Warranty card <D>			

NOTE : <D> : USA model only
 <DT> : Taiwanese model only
 <P> : European model only
 <PT> : Asian model only

ONKYO CORPORATION

Sales & Product Planning Div. : 2-1, Nisshin-cho, Neyagawa-shi, OSAKA 572-8540, JAPAN
 Tel: 0720-31-8111 Fax: 0720-33-5222

ONKYO U.S.A. CORPORATION

200 Williams Drive, Ramsey, N.J. 07446, U.S.A.
 Tel: 201-825-7950 Fax: 201-825-8150 E-mail: onkyo@onkyousa.com

ONKYO EUROPE ELECTRONICS GmbH

Industriestrasse 20, 82110 Germering, GERMANY
 Tel: 089 84 93 20 Fax: 089 84 93 226 E-mail: irfo@onkyo.de

ONKYO CHINA LIMITED

Units 2102-7, Metroplaza Tower I, 223 Hing Fong Road, Kwai Chung,
 N.T., HONG KONG Tel: 852 2429 3118 Fax: 852 2428 9039



Printed in Japan