

ONKYO® SERVICE MANUAL

Integrated Stereo Amplifier MODEL A-911

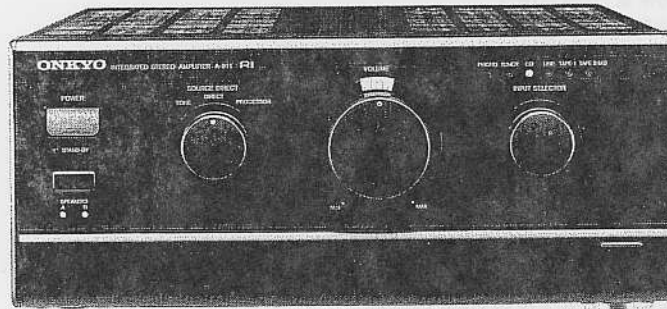

Black and Silver models

UP	230V AC, 50Hz
UW	120V/220V AC, 50Hz/60Hz

SAFETY-RELATED COMPONENT WARNING!!

COMPONENTS IDENTIFIED BY MARK Δ ON THE SCHEMATIC DIAGRAM AND IN THE PARTS LIST ARE CRITICAL FOR RISK OF PARTS.

WHOSE PARTS NUMBERS APPEAR AS SHOWN IN THIS MANUAL.

MAKE LEAKAGE-CURRENT OR RESISTANCE MEASUREMENTS TO DETERMINE THAT EXPOSED PARTS ARE ACCEPTABLY INSULATED FROM THE SUPPLY CIRCUIT BEFORE RETURNING THE APPLIANCE TO THE CUSTOMER.

TABLE OF CONTENTS

Specifications	2
Block diagram	3
Precautions	5
Adjustment procedures	5
IC block diagram	6
Printed circuit board parts list	9
Packing parts list	13
Chassis exploded view	14
Front / Rear panel facilities	17
System connections	18
Printed circuit board view	19
Schematic diagram	23

ONKYO
AUDIO COMPONENTS

SPECIFICATIONS

Power output:	40 watts per channel, min RMS, at 8 ohms, both channels driven from 20 Hz to 20 kHz, with no more than 0.06% THD. 2 × 70 watts at 4 ohms, 1 kHz(DIN) 2 × 50 watts at 8 ohms, 1 kHz(DIN)
Total harmonic distortion:	0.06% at rated power
IM distortion:	0.06% at rated power
Damping factor:	60 at 8 ohms
Frequency and response:	15-30,000 Hz ±1 dB
Input sensitivity/impedance:	Phono (MM): 2.5 mV/50 kohms Tuner/CD/LINE: 150 mV/50 kohms Tape/Play: 150 mV/50 kohms Processor In: 150 mV/50 kohms
Output sensitivity/impedance:	Tape/Rec: 150 mV/3 kohms (phono) Processor Out: 150 mV/2.2 kohms Mono Out: 1V/600 ohms
Phono overload:	135 mV RMS at 1 kHz, 0.1% THD (MM) (REC)
S.Bass control:	±10 dB at 55 Hz
Bass control:	±10 dB at 100 Hz
Treble control:	±10 dB at 10,000 Hz
Signal to noise ratio (IHF-A):	Phono (MM): 85 dB (5 mV input) CD: 100 dB

General

Power supply:	European models (except U.K.): AC 230V, 50Hz Canadian models: AC 120V, 60Hz U.K. & Australian models: AC 240V, 50Hz Worldwide models: AC 120 and 220V switchable, 50/60Hz
Dimensions:	275 (W) × 118 (H) × 335 (D) mm 10-7/8" × 4-5/8" × 13-3/16"
Weight:	6.2 kg, 13.7 lbs.

Specifications and features are subject to change without notice.

BLOCK DIAGRAM

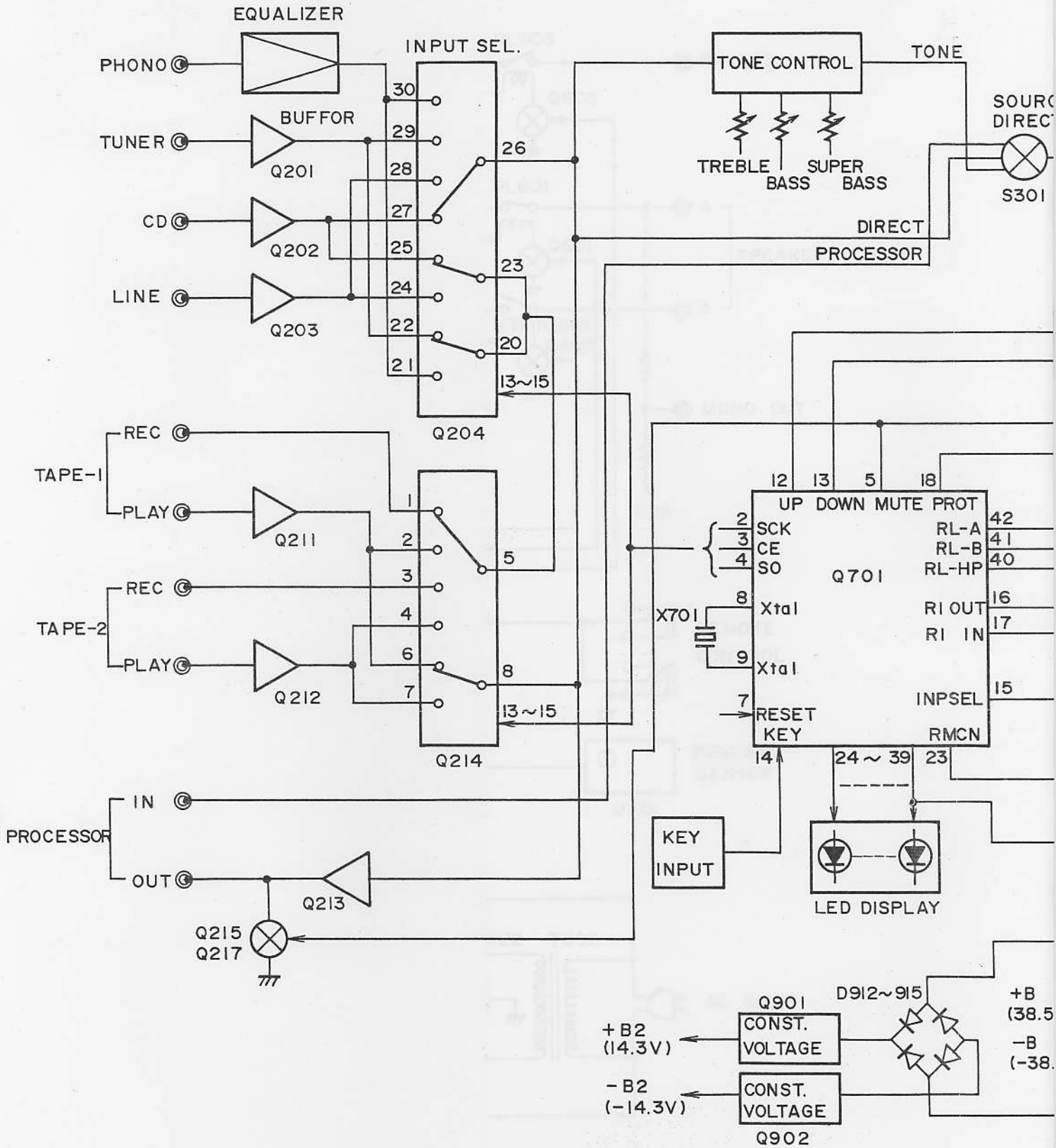

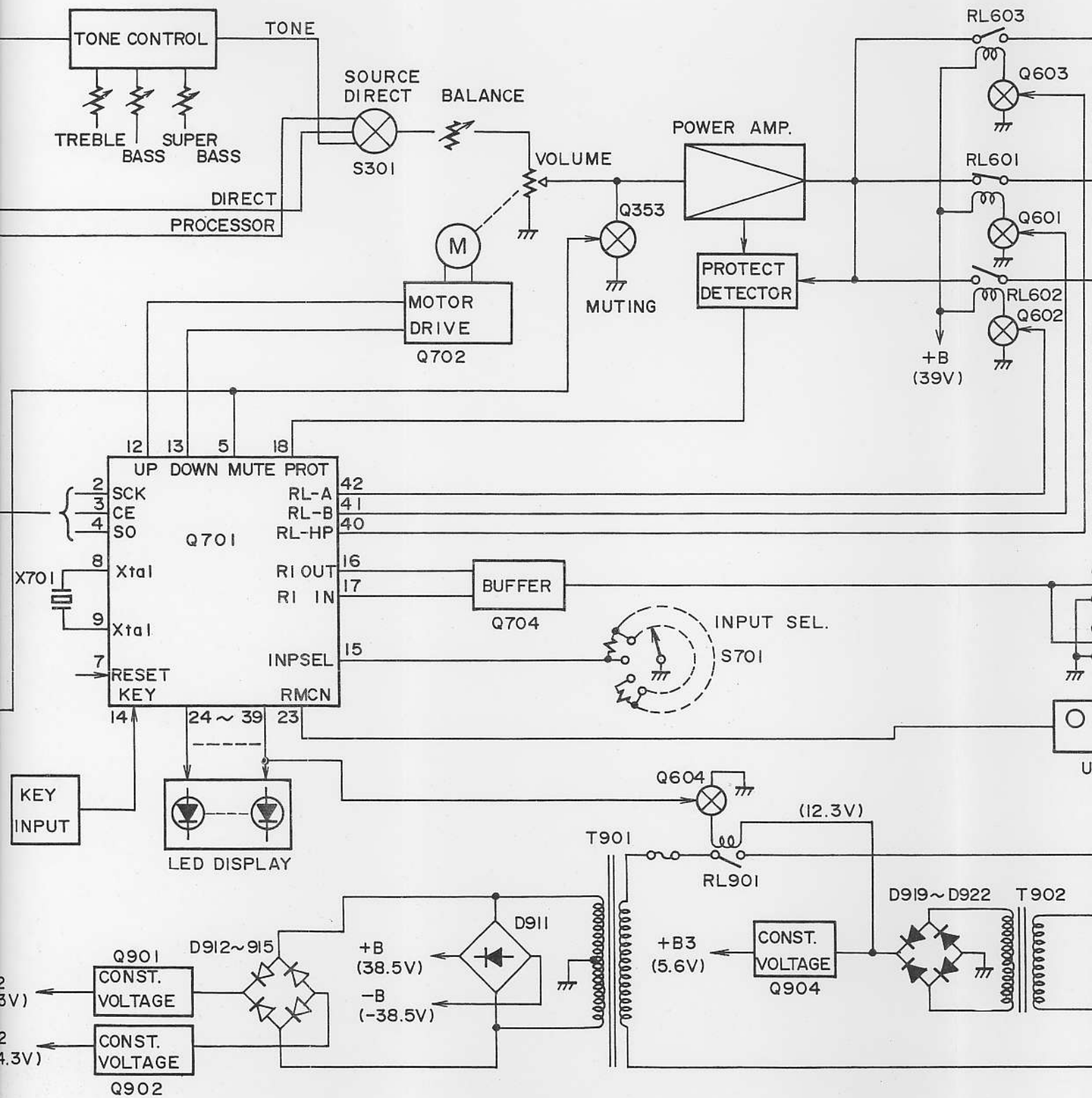

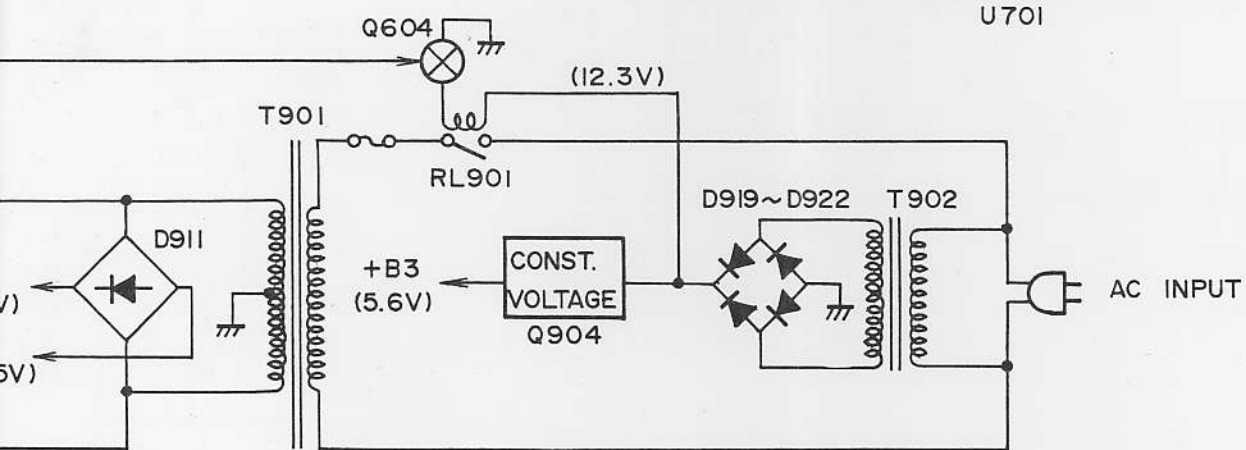
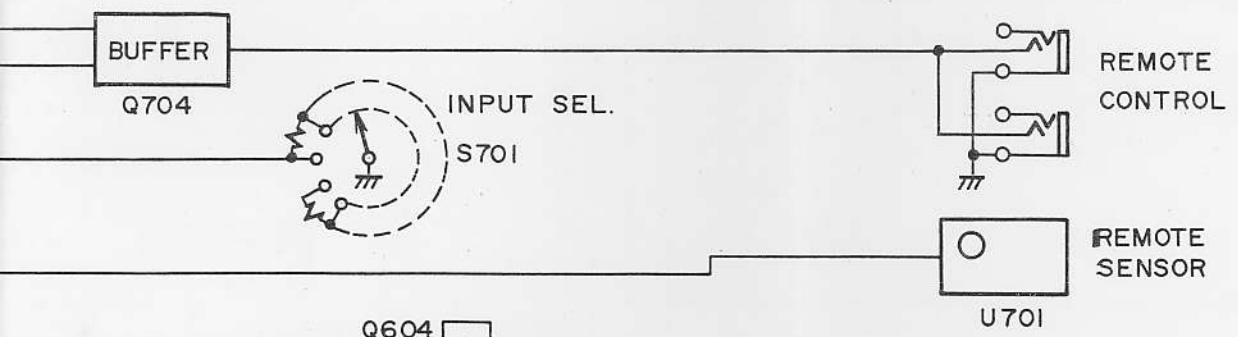
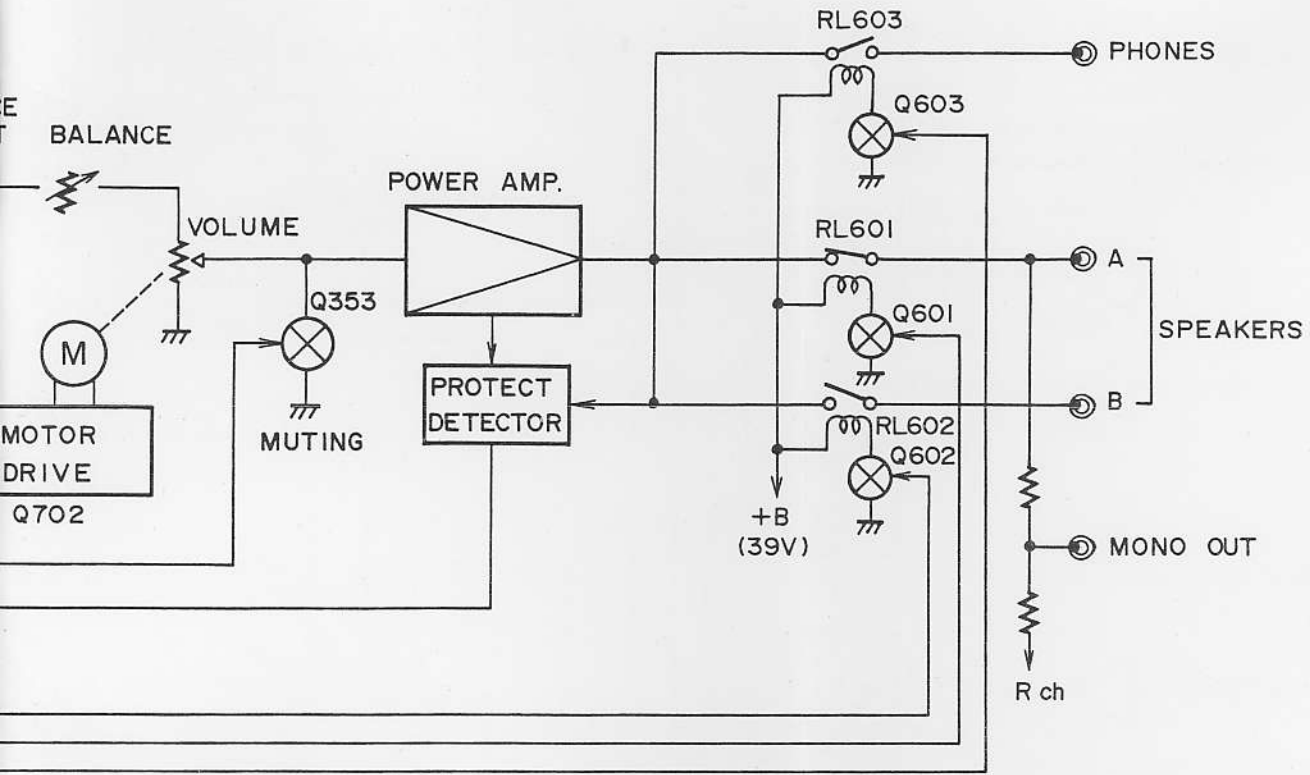

PRECAUTIONS

1. Replacing the fuses

For continued protection against risk fire, replace only with same type and same rating fuse.

CIRCUIT NO.	PART NO.	DESCRIPTION
F901	252152	5A-TSC, Primary fuse (120V/220V models)
F902	252075 or 252075CC	2.5A-SE-EAK or 2.5A-SE-EAK, Primary fuse (120V/220V models)
F903,F904	252074	2A-SE-EAK or
F905	252074CC	2A-SE-EAK, Primary fuse (230V models)

2. Insulation resistance measurement (Only U.S.A. model)

Connect the insulating-resistance tester between the plug of power supply cable and terminal GND on the back panel. Specifications; More than 10 M Ω at 500V.

3. Voltage Selector (Rear Panel)

Worldwide models are equipped with a voltage selector to conform to local power supplies.

Be sure to set this switch to match the voltage of the power supply in your area before plugging in the unit. Models without a voltage selector can only be used in areas where the power supply is the same as that of the unit.

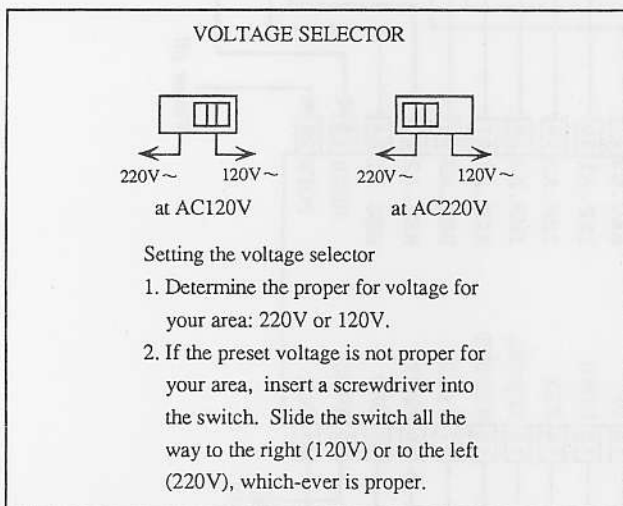

ADJUSTMENT PROCEDURES

1. Preparations

- 1) Place the unit on the workbench. (There should be about 15 mm of space between the base plate of the unit and the work surface.)
- 2) Set up the unit as follows.
 - (1) No load
 - (2) No signal
 - (3) Volume turned all the way down
 - (4) Speaker switch OFF
 - (5) Power switch OFF

Note) Check the following points before making adjustments

- (1) The power switch should be OFF.
- (2) The interior of the unit should not be warm.

2. Idling current adjustment

- 1) Turn the power switch ON and allow the unit to warm up for about 10 minutes.
 - (1) Adjust R531 (R532) so that the voltage at test point VCT-ID on the NAAF-4809 circuit board is 7.5mV \pm 3.5mV

NOTE) Semi-fixed resistors enclosed in parentheses () are for the right channel.

IC BLOCK DIAGRAM DIAGRAM

HD404314A05S (Microprocessor)

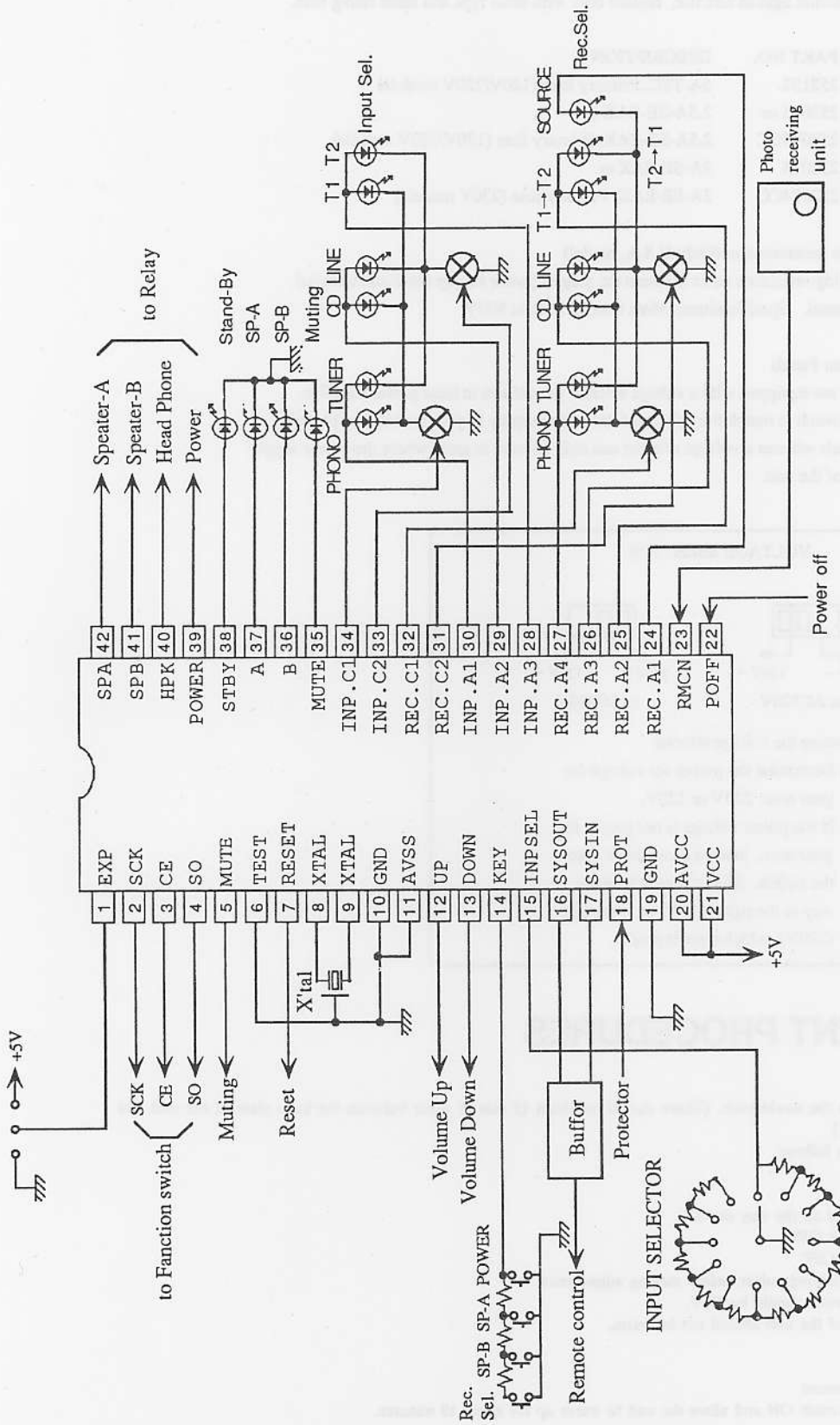

HD404314

Pin No.	CODE	FUNCTION	I/O	DESCRIPTION
1	RA1/Vdisp	JPN/EXP	IN	Input terminal for change-over between Japan model and Export model
2	ROO/SCK	SCK(CL)	OUT	Connect to the terminal CL of Analog switch
3	R01/SI	CE	OUT	Connect to the terminal CE of Analog switch
4	R02/SO	SO(DI)	OUT	Connect to the terminal DI of Analog switch
5	R03/TOC	MUT	OUT	Muting output terminal. "H" When muting is ON.
6	TEST	GND	----	Used by connecting to ground for testing IC internal
7	RESET	RESET	IN	Input terminal for Reset signal
8	OSC1	Xtal	----	Terminal for connecting with Ceramic oscillator (4MHz)
9	OSC2	Xtal	----	
10	GND	GND	----	Ground terminal
11	AVss	GND	----	Ground terminal of A/D converter
12	R30/AN0	VOLUME UP	OUT	UP/DOWN output terminal for Volume
13	R31/AN1	VOLUME DOWN	OUT	
14	R32/AN2	KEY	IN	Input terminal for Input key
15	R33/AN3	INP SEL	IN	Input terminal for Input Selector switch
16	R40/AN4	RI.OUT	OUT	Output terminal for System code. Active "L".
17	R41/AN5	RI.INPUT	IN	Input terminal for Input Selector switch. Active "H".
18	R42/AN6	PROTECT	IN	Input terminal for detecting protect operation
19	R43/AN7	GND	----	Not used
20	AVcc	+5V	----	Power(+5V) connecting terminal
21	Vcc	+5V	----	Power(+5V) terminal A/D converter
22	D0/INT0	POFF	IN	Input terminal for detecting power suspension
23	D1/INT1	RMCN	IN	Remote control signal input terminal
24	D2/EVENB	REC.A1	OUT	Anode output terminal for Rec.Selector LED
25	D3/BUZZ	REC.A2	OUT	
26	D4/STOPC	REC.A3	OUT	
27	D5	REC.A4	OUT	
28	D6	INP.A3	OUT	Anode output terminal for Input Selector LED
29	D7	INP.A2	OUT	
30	D8	INP.A1	OUT	
31	R80	REC.C2	OUT	
32	R81	REC.C1	OUT	
33	R81	INP.C2	OUT	Cathode output terminal for Input Selector LED
34	R83	INP.C1	OUT	
35	R10	MUTE.LED	OUT	Output terminal for Muting LED
36	R11	SP-B.LED	OUT	Output terminal for Speaker-B LED
37	R12	SP-A.LED	OUT	Output terminal for Speaker-A LED
38	R13	STAND-BY.LED	OUT	Output terminal for Stand-by LED
39	R20	POWER	OUT	Output terminal for Power control. "H" When power ON.
40	R21	HP.RELAY	OUT	Output terminal for controlling Head phone relay. "H" When ON.
41	R22	SP-B.RELAY	OUT	Output terminal for controlling Speaker-B relay. "H" When ON.
42	R23	SP-A.RELAY	OUT	Output terminal for controlling Speaker-A relay. "H" When ON.

BA15218N (OP Amp.)
NJM4558LD

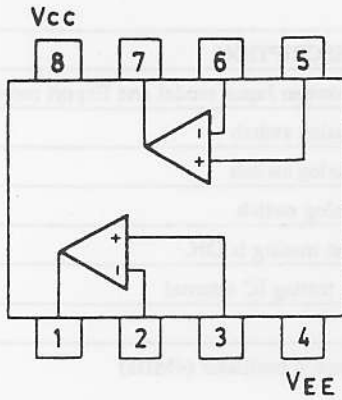

NJM4565SD (OP Amp.)

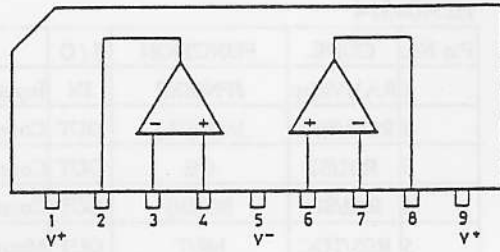

TC7291S (Volume Motor Drive)

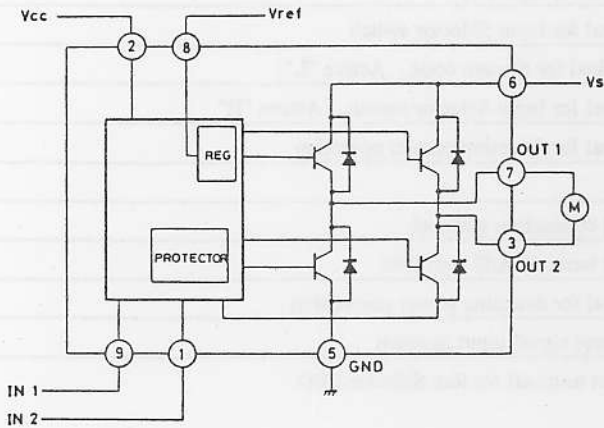

INPUT		OUTPUT		MODE
IN 1	IN 2	OUT 1	OUT 2	
0	0	∞	∞	STOP
1	0	H	L	CW/CCW
0	1	L	H	CCW/CW
1	1	L	L	BRAKE

CCW: Counter clockwise direction
CW: Clockwise direction

LC7821N (Analog Switch)

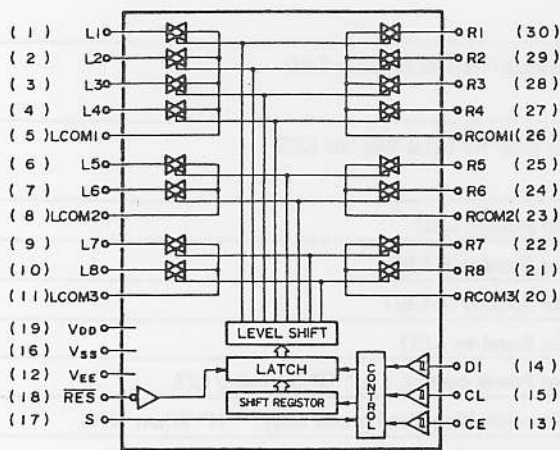

PRINTED CIRCUIT BOARD - PARTS LIST

MAIN CIRCUIT PC BOARD (NAAF-4809-1, -1A)

CIRCUIT. NO.	PART NO.	DESCRIPTION	CIRCUIT. NO.	PART NO.	DESCRIPTION
	ICs				
Q211-Q213	22240293 or 22240247	NJM4558L-D or BA15218N	D601-D603	223163 or 223205 or 223222	1SS133 or 1SS270A or WG713A
Q214	22240280	LC7821N	D911	22380038	RBV602
	Transistors		D912-D915	22380046 or 22380035	AM01Z or GP104003E
Q215,Q216	2213631 or 2213632	RN1241-A or RN1241-B	D916,D917	224451503	MTZ15C, Zener
Q217	2213510	DTA114ES	D919-D922	22380046 or 22380035	AM01Z or GP104003E
Q501,Q502	2213677 or 2213678	2SC3067-G or 2SC3067-H	D923	224450623	MTZ6.2C, Zener
Q505-Q508	2211455 or 2214905	2SA1015-GR or 2PA1015-GR	D924,D925	22380046 or 22380035	AM01Z or GP104003E
Q509,Q510	2211732 or 2211733	2SC1845-F or 2SC1845-E	D926	224450512	MTZ5.1B, Zener
Q511,Q512	2211255 or 2214915	2SC1815-GR or 2PC1815-GR		Coils	
Q513,Q514	2211354 or 2211353	2SA949-Y or 2SA949-O	L501,L502	231176S or 231176SY	S-1.3C or S-1.3C
Q515,Q516	2211634 or 2211633	2SC2229-Y or 2SC2229-O		Capacitors	
Q517,Q518	2212654 or 2212653	2SC3421-Y or 2SC3421-O	C251-C254	374723315	330 pF, 50V, Film(TF) [P]
Q519,Q520	2212644 or 2212643	2SA1358-Y or 2SA1358-O	C265,C266	393380227	2.2 μ F/50V, Elect.(VX)
Q525,Q526	2211732 or 2211733	2SC1845-F or 2SC1845-E	C269	393380107	1 μ F/50V, Elect.(VX)
Q527	2211792 or 2211793	2SA992-F or 2SA992-E	C271	393380337	3.3 μ F/50V, Elect.(VX)
Q528,Q529	2211732 or 2211733	2SC1845-F or 2SC1845-E	C273-C276		
Q531,Q532	2211183	2SC1740-R	C503,C504	374721015	100 pF/50V, Film(TF)
Q601-Q603	2213650	DTD113ZS	C505,C506	374721015	100 pF/50V, Film(TF) [P]
Q901	2202116 or 2202115	2SD2061-F or 2SD2061-E	C507,C508	374721024	1000 pF/50V, Film(TF)
Q902	2202176 or 2202175	2SB1370-F or 2SB1370-E	C509,C510	393322217	220 μ F/6.3V, Elect.(VX)
Q904	2202116 or 2202115	2SD2061-F or 2SD2061-E	C511,C512	393380337	3.3 μ F/50V, Elect.(VX)
	Diodes		C517-C520	374722234	0.022 μ F/50V, Film(TF)
D501-D504	223163 or 223205 or 223222	1SS133 or 1SS270A or WG713A	C525,C526	374724734	0.047 μ F/50V, Film(TF)
D551	224450512	MTZ5.1B, Zener	C529-C532	393381017	100 μ F/50V, Elect.(VX)
			C537,C538	374724734	0.047 μ F/50V, Film(TF) [W]
			C541-C544	374721024	1000 pF/50V, Film(TF) [P]
			C554	393380477	4.7 μ F/50V, Elect.(VX)
			C555	393322217	220 μ F/6.3V, Elect.(VX)
			C601,C602	374722234	0.022 μ F/50V, Film(TF)
			C911,C912	374731034	0.01 μ F/100V, Film(TF)
			C914,C915	3500180A	10000 μ F/50V, Elect.
			C916,C917	393382227	2200 μ F/50V, Elect.(VX)
			C918,C919	393361017	100 μ F/35V, Elect.(VX)
			C920,C921	393341017	100 μ F/16V, Elect.(VX)
			C922,C923	393342217	220 μ F/16V, Elect.(VX)
			C931	393342227	2200 μ F/16V, Elect.(VX)
			C932	393341017	100 μ F/16V, Elect.(VX)
			C934	393343317	330 μ F/16V, Elect.(VX)

VOLUME CONTROL CIRCUIT PC BOARD (NAAF-4810-1)

CIRCUIT. NO.	PART NO.	DESCRIPTION	CIRCUIT. NO.	PART NO.	DESCRIPTION
C935	393321017	100 μ F/6.3V,Elect.(VX)		Transistors	
C936	393344707	47 μ F/16V,Elect.(VX)	Q353,Q354	2212285 or	2SC2878-A or
C938	393341007	10 μ F/16V,Elect.(VX)		2212286	2SC2878-B
	Resistors			Capacitors	
R527,R528	443522704	27 Ω ,1/2W,Metal oxide film	C357	393380107	1 μ F/50V, Elect.(VX)
R529,R530	443529104	91 Ω ,1/2W,Metal oxide film	C501,C502	393380477	4.7 μ F/50V, Elect.(VX)
R531,R532	5210062	N06HR4.7KBD,Semi-fixed	C527,C528	374721035	0.01 μ F/50V, Film(TF)
R535,R536	443522714	270 Ω ,1/2W,Metal oxide film	C711	374722734	0.027 μ F/50V, Film(TF)
R537,R538	451730104	1 Ω ,2W,Metal		Resistors	
R539,R540	4500033	0.47 Ω ,.5W,Metal plate	R351(R352)	5142011	N16RGM50KA30F,Variable
R543-R546	453530224	2.2 Ω ,1/2W,Metal		Sockets	
R547,R548	453530824	8.2 Ω ,1/2W,Metal	P301	25050986	NSCT-14P773
R549,R550	453530564	5.6 Ω ,1/2W,Metal	P302	25050984	NSCT-10P771
R553-R556	453530224	2.2 Ω ,1/2W,Metal	P501,P911	25050982	NSCT-6P769
R601,R602	441627514	750 Ω ,1W,Metal oxide film		Wire trap	
R603	443522724	2.7k Ω ,1/2W,Metal oxide film	JL702	25050531	NSCT-9P354
R911,R912	443723914	390 Ω ,2W,Metal oxide film		Plugs	
R915,R916	443521824	1.8 Ω ,1/2W,Metal oxide film	P303	25055416	NPLG-14P398
R931	441621804	18 Ω ,1W,Metal oxide film	P304	25055659	NPLG-10P615
R932,R933	443524714	470 Ω ,1/2W,Metal oxide film		Shield wire	
R934	443521224	1.2k Ω ,1/2W,Metal oxide film	JL301	25050033	NCS-9P5E15
R935	443521024	1k Ω ,1/2W,Metal oxide film			
	Relays				
RL601,RL602	25065339	NRL-2P5A-DC24V-46			
RL603	25065470	NRL-2P1A-DC24V-079			
	Heat sink				
Q901a,Q902a	27160145 or 27160145-1	RAD-51 or RAD-51			
Q931a	27160211 or 27160211Y	RAD-68 or RAD-68			
D911a	27160166				

SOURCE DIRECT SWITCH CIRCUIT PC BOARD (NASW-4811-1)

CIRCUIT. NO.	PART NO.	DESCRIPTION	CIRCUIT. NO.	PART NO.	DESCRIPTION
				Switch	
			S301	25030368A	NRS-143-20S, Rotary switch

TONE CONTROL CIRCUIT PC BOARD (NAAF-4812-1)

CIRCUIT. NO.	PART NO.	DESCRIPTION	CIRCUIT. NO.	PART NO.	DESCRIPTION
				ICs	
P302	25055650	NPLG-10P606	Q301,Q321	22240273	NJM4565S-D
P305	25055412	NPLG-10P394	Q331		
P501	25055648	NPLG-6P604		Capacitors	
P601,P602	25055493	NPLG-2P468	C301,C302	393380107	1 μ F/50V, Elect.(VX)
P911	25055648	NPLG-6P604	C305,C306	393380227	2.2 μ F/50V, Elect.(VX)
P912	25055258	NPLG-6P241	C321,C322	374723334	0.033 μ F/50V, Film(TF)
P921	25055166	NPLG-3P150	C325,C326	393380227	2.2 μ F/50V, Elect.(VX)
	Plate		C327,C328	374721834	0.018 μ F/50V, Film(TF)
	27141059		C331,C332	393380227	2.2 μ F/50V, Elect.(VX)
			C333,C334	374723934	0.039 μ F/50V, Film(TF)
			C391,C392	393380337	3.3 μ F/50V, Elect.(VX)

CIRCUIT. NO.	PART NO.	DESCRIPTION	CIRCUIT. NO.	PART NO.	DESCRIPTION
	Resistors				
R321(R322)	5104328	N14RLC100KWT15Z, Variable	D703	223163 or 223205 or 223222	1SS133 or 1SS270A or WG713A
R325(R326)			D704	224450562	MTZ5.6B, Zener
R333(R334)			D705-D707	223163 or	1SS133 or
R341	5104258	N11RGLC250KWT15Z, Variable	D710	223205 or 223222	1SS270A or WG713A
P303	Socket 25050682	NSCT-14P486	D721-D726	225291D	SEL4910D-D, LED
JL571	Wire trap 25050280	NSCT-3P108	D727	225292D	SEL4310G-D, LED
			D728-D733	225290	SEL4110R, LED
			D734	225141	SEL2213C, LED
			D735,D736	225142DX2	SEL2913K-DX2, LED

STEREO HEADPHONE TERMINAL PC BOARD (NAETC-4813-1)

CIRCUIT. NO.	PART NO.	DESCRIPTION	CIRCUIT. NO.	PART NO.	DESCRIPTION
	Resistors		X701	Resonator 3010150	CST4.00MGW
R571,R572	441623914	390 Ω , 1W, Metal oxide film	C701	Capacitors 393341007	10 μ F/16V, Elect.(VX)
P571	Jack 25045275	YKB26-5138	C703	393381097	0.1 μ F/50V, Elect.(VX)
JL571	Wire holder 25051107	NSCT-3P894	C705	393341007	10 μ F/16V, Elect.(VX)
			C708	3020027	5R5U473, Super
			C709	375524744	0.47 μ F/50V, Film(MMT)
			R728,R729	Resistors 49163103404	10k \times 4, Network
			R730	49163104404	100k \times 4, Network

CONNECTION PC BOARD (NAETC-4814-1)

CIRCUIT. NO.	PART NO.	DESCRIPTION	CIRCUIT. NO.	PART NO.	DESCRIPTION
	Sockets		S701	25030345	NPS-1112-15SRM
P304	25051046	NSCT-10P833	S705	25035652	NPS-111-S604
P305	25050678	NSCT-10P482	JL701-JL703	Wier holder 25051103	NSCT-9P890

MICROPROCESSOR CIRCUIT PC BOARD (NADG-4816-1)

CIRCUIT. NO.	PART NO.	DESCRIPTION	CIRCUIT. NO.	PART NO.	DESCRIPTION
	ICs			Holder 27190933A	Holder(VOL)
Q701	22240729	HD404314A05S		Terminal 25060118	NTM-1S52
Q702	22240239	TA7291S			
	Transistors				
Q703	2213284	2SC1740S-R			
Q704	2213510	DTA114ES			
Q705-Q708	2213290	DTC114ES			
Q709	2213640	DTC123JS			
Q710	2213290	DTC114ES			
	Diodes				
D701	22380046 or 22380035	AM01Z or GP104003E			

REMOTE CONTROL SENSOR CIRCUIT PC BOARD (NADIS-4817-1)

CIRCUIT. NO.	PART NO.	DESCRIPTION	CIRCUIT. NO.	PART NO.	DESCRIPTION
	Remote control sensor				
U701	24130007	GP1U571X			
	Diodes				
D711	223163 or 223205 or 223222	1SS133 or 1SS270A or WG713A			
D737	225290	SEL4110R, LED			
D738,D739	225291D	SEL4910D-D, LED			

CIRCUIT. NO.	PART NO.	DESCRIPTION	CIRCUIT. NO.	PART NO.	DESCRIPTION
C715	Capacitors 393341007	10 μ F/16V, Elect.(VX)	P701	Stereo jack 25045330	NPJ-2PDBL184
P702-P704	Switches 25035652	NPS-111-S604	POWER SUPPLY CIRCUIT PC BOARD (NAPS-4819-1A)		
JL703	Wire holder 25051103	NSCT-9P890	CIRCUIT. NO. PART NO. DESCRIPTION		
INPUT TERMINAL CIRCUIT PC BOARD (NAAF-4818-1,-1A)			Q604	Transistor 2213650	DTD113ZS
CIRCUIT. NO. PART NO. DESCRIPTION			D604	Diode 223163 or 223205 or 223222	1SS133 or 1SS270A or WG713A
Q105	ICs 22240191	NJM4565D-D	Δ T902	Transformer 2300948	NPT-1184DG [W]
Q201-Q203	22240293 or 22240247	NJM4558L-D or BA15218N	Δ C901,C902	Capacitors 3500065A	0.01 μ F/AC400V,125V, Film(IS)
Q204	22240280	LC7821N	R936	Resistors 453530224	2.2 Ω ,1/2W,Metal
Q101-Q104	Transistors 2211782 or 2211783	2SA991-F or 2SA991-E	R937	443525604	56 Ω ,1/2W,Metal oxide film
D101-D104	Diodes 223163 or 223205 or 223222	1SS133 or 1SS270A or WG713A	Δ F901	Fuse holders 25050065	YSH403T
C101,C102	Capacitors 374721015	100 pF/50V, Film(TF) [P,W]	Δ F902	25050065	YSH403T [W]
C105,C106	393380477	4.7 μ F/50V, Elect.(VX)	Δ P901	Post plug 25055675	NPLG-2P631
C107,C108	374722215	220 pF/50V, Film(TF)	Δ P903	Socket 25050640	NSCT-4P451 [W]
C109,C110	374723315	330 pF/50V, Film(TF) [P,W]	P912	25050302	NSCT-6P129
C111,C112	374728224	8800 pF/50V, Film(TF)	Δ RL901	Relay 25065248	NRL-1P15A-DC12V-29 [W]
C113,C114	393322217	220 μ F/6.3V, Elect.(VX)	F901a	Spec label 29360405	T2.5A/250V [W]
C115,C116	374721134	0.011 μ F/50V, FILM(TF)	POWER SUPPLY CIRCUIT PC BOARD (NAPS-4820-1)		
C117,C118	371123034	0.03 μ F/50V, Mylar	CIRCUIT. NO. PART NO. DESCRIPTION		
C119,C120	393380477	4.7 μ F/50V, Elect.(VX)	Q604	Transistor 2213650	DTD113ZS
C121,C122	374721224	1200 pF/50V, Film(TF)			
C132,C133	393341017	100 μ F/16V, Elect.(VX)			
C134	374722235	0.022 μ F/50V, Film(TF)			
C201-C206	374723315	330 pF/50V, Film(TF) [P,W]			
C221,C223	393380337	3.3 μ F/50V, Elect.(VX)			
C224					
C225,C226	391642217	220 μ F/16V, Elect.(FS)			
P101	Terminals 25045398	NPJ-2PDWH223			
P201	25045399A	NPJ-6PDWH224			
P301	Pin plug 25055652	NPLG-14P608			

CHASSIS-EXPLODED VIEW-PARTS LIST

CIRCUIT. NO.	PART NO.	DESCRIPTION	CIRCUIT. NO.	PART NO.	DESCRIPTION
D604	Diode 223163 or 223205 or 223222	1SS133 or 1SS270A or WG713A	P922	Socket 2009990298	NSAS-3P0432, Socket ass'y
△ T902	Transformer 2300947	NPT-1184P	SLIDE SWITCH PC BOARD (NASW-4823)		
C604	Capacitors 374722234	0.022 μ F/50V, Film(TF)	S901	Switch 25065437	NSS-22157P, Slide
△ C901	3500077	0.0047 μ F, Film(IS)	NOTE :		
△ C902	3500065A	0.01 μ F/AC400V,125V, Film(IS)	[P]: 230V Model only		
R936	Resistor 453530224	2.2 Ω , 1/2W, Metal	[W]: World wide model		
R937	443525604	56 Ω , 1/2W, Metal oxide film	<div style="border: 1px solid black; padding: 5px;"> NOTE: THE COMPONENTS IDENTIFIED BY MARK Δ ARE CRITICAL FOR RISK OF FIRE AND ELECTRIC SHOCK. REPLACE ONLY WITH PART NUMBER SPECIFIED. </div>		
△ F903-F905	Fuse holders 25050065	YSH403T			
P901	Post plug 25055675	NPLG-2P631			
P912	Socket 25050302	NSCT-6P129			
△ RL901	Relay 25065248	NRL-1P15A-DC12V-29			

PACKING PARTS LIST

REF.NO.	PART NO.	DESCRIPTION	
A851	29052661	CARTON BOX	[BLK]
	29052662	CARTON BOX	[SIL]
A852	29091642A	PAD(L)	
A853	29091643A	PAD(R)	
A856	29100037A	650 \times 500, POLY BAG	
A861	261504	PAPER TAPE	
A863	282321 or 282301	STAPLE or STAPLE	
A861	29110071	PP TAPE	
A911	29361573	LABEL(PE-LD)	[V]
A913	29361574	LABEL(PE-HD)	[V]

<ACCESSORY BAG ASS'Y>

29341869	INSTRUCTION MANUAL	[P]
29341867	INSTRUCTION MANUAL	[V]
29341868	INSTRUCTION MANUAL	[W]
29355204	INSTRUCTION SHEET	
29365020H	WARRANTY CARD	[V]
29100094B	POLY BAG(WARRANTY)	[V]
24140259	RC-259S, REMOTE CONTROL TRANSMITTER	
3010054	UM-3, BATTERIES	
29100097	320 \times 250, POLY BAG	
25055040	CV-K-2, CONVERSION PLUG	[W]

NOTE: [P]: 230V MODEL ONLY
 [W]: WORLD WIDE MODEL ONLY
 [V]: GERMANY MODEL ONLY
 [BLK]: BLACK MODEL ONLY
 [SIL]: SILVER MODEL ONLY

CHASSIS-EXPLODED VIEW - PARTS LIST

REF.NO.	PART NO.	DESCRIPTION	REF.NO.	PART NO.	DESCRIPTION
A001	27110783A	FRONT BRACKET [BLK]		28324876B	KNOB(TONE) [SIL]
	27110784A	FRONT BRACKET [SIL]	A807	28324874A	KNOB(REC) [BLK]
A002	27130726	BRACKET (L)		28324877A	KNOB(REC) [SIL]
A003	27100272A	CHASSIS	A809	28324930	KNOB(VOL) ASS'Y [BLK]
A005	27121779A	REAR PANEL [P]		28324931	KNOB(VOL) ASS'Y [SIL]
A005	27121780A	REAR PANEL [W]	A809a	(28324865)	KNOB(VOL) [BLK]
A006	27270332	SPACER		(28324867)	KNOB(VOL) [SIL]
A007	27141620	RETAINER (PT)	A809b	(27180537)	SPRING
A008	27141579	RETAINER (S)	Q521,Q522	2201703	2SC3855-O OR
A009	27160329	HEAT SINK		2201704	2SC3855-Y OR
A010	8761301210	W3 X 12F, WASHER		2201706	2SC3855-P, TRANSISTOR
A011	27300750	#2271, CORD BUSHING	Q523,Q524	2201693	2SA1491-O OR
A012	27150367A	SHILD PLATE(SEL)		2201694	2SA1491-Y OR
A013	27190524	HOLDER		2201696	2SA1491-P, TRANSISTOR
A014	27190802	HOLDER	△ T901	2300942A	NPT-1183P, POWER TRANSFORMER [P]
A015	834430088	3TTS+8B(BC), SCREW	△ T901	2300943B	NPT-1183DG, POWER TRANSFORMER [W]
A016	833430080	3TTP+8P(BC), SCREW	△ P901	253193HIT	AS-CEE, AC CORD [P,W]
A017	8300440089	4TTC+8C(BC), SCREW	△ F901	252152	5A-TSC, FUSE [W]
A018	801433	3SMS8W.SW+14B(BC), SCREW	△ F902	252075	2.5A-SE-EAK OR
A019	831130088	3TTW+8B, SCREW		252075CC	2.5A-SE-EAK, FUSE [W]
A020	834426068	2.6TTS+6B(BC), SCREW	△ F903,F904	252074	2A-SE-EAK OR
A021	82143006	3P+6FN(BC), SCREW	△ F905	252074CC	2A-SE-EAK, FUSE [P,V]
A024	838426088	2.6TTB+8B(BC), SCREW	△ P904,P905	25050337	NSCT-2P164, AC OUTLET [P]
A301	28184547	COVER [BLK]	U1	1A447509-1	NAAF-4809-1, MAIN CIRCUIT PC BOARD ASS'Y [W]
	28184548	COVER [SIL]	U1	1A447509-1A	NAAF-4809-1A, MAIN CIRCUIT PC BOARD ASS'Y [P]
A302	28141281	CUSHION	U2	1A447510-1	NAAF-4810-1, VOLUME CONTROL CIRCUIT PC BOARD ASS'Y
A303	834430088	3TTS+8B(BC), SCREW	U3	1A447511-1	NASW-4811-1, SOURCE DIRECT SWITCH CIRCUIT PC BOARD ASS'Y
A305	28141283	φ 5, CUSHION	U4	1A447512-1	NAAF-4812-1, TONE CONTROL CIRCUIT PC BOARD ASS'Y
A306	28141284	φ 2, CUSHION	U5	1A447513-1	NAETC-4813-1, STEREO HEADPHONE TERMINAL PC BOARD ASS'Y
A310	27175294Y	LEG ASS'Y	U6	1A447514-1	NAETC-4814-1, CONNECTION PC BOARD ASS'Y
A311	834430088	3TTS+8B(BC), SCREW	U7	1A447516-1	NADG-4816-1, MICROPROCESSOR PC BOARD ASS'Y
A500	1A447121	FRONT PANEL ASS'Y [BLK]	U8	1A447517-1	NADIS-4817-1, REMOTE CONTROL SENSOR CIRCUIT PC BOARD ASS'Y
	1A448121	FRONT PANEL ASS'Y [SIL]	U9	1A447518-1A	NAAF-4818-1A, INPUT TERMINAL CIRCUIT PC BOARD ASS'Y [P,W]
A502	28135199Y	BADGE	U10	1A447519-1A	NAPS-4819-1A, POWER SUPPLY CIRCUIT PC BOARD ASS'Y [W]
A503	27267831-1	GUIDE(VOL) [BLK]	U11	1A447520-1	NAPS-4820-1, POWER SUPPLY CIRCUIT PC BOARD ASS'Y [P]
	27267831	GUIDE(VOL) [SIL]	U12	1A477521-1	NAETC-4821-1, TRANSFORMER TERMINAL PC BOARD ASS'Y
A504	28198796	FACET(VOL)	U13	1A477522-1	NAETC-4822-1, TRANSFORMER TERMINAL PC BOARD ASS'Y
A505	28198797	FACET(7)	U14	1A477523-1	NASW-4823-1, SLIDE SWITCH PC BOARD ASS'Y [W]
A506	28198795	FACET			
A507	28199199A	FILM	NOTE :	[P] : 230V MODEL ONLY	
A510	28191665	CLEAR PLATE(RE)		[W] : WORLD WIDE MODEL ONLY	
A512	28148279A	DOOR [BLK]		[BLK] : BLACK MODEL ONLY	
	28148280A	DOOR [SIL]		[SIL] : SILVER MODEL ONLY	
A513	28180112	HINGE(L)			
A514	28180113	HINGE(R)			
A515	28180107A	HINGE(HL)			
A516	28180108A	HINGE(HR)			
A517	27267832	GUIDE(TONE) [BLK]			
	27267833A	GUIDE(TONE) [SIL]			
A518	28140860	CUSHION			
A519	28324914-1	KNOB(DOOR) [BLK]			
	28323779-1	KNOB(DOOR) [SIL]			
A802	28324868	KNOB(DIR) [BLK]			
	28324870	KNOB(DIR) [SIL]			
A803	28324869	KNOB(SEL) [BLK]			
	28324871	KNOB(SEL) [SIL]			
A804	28324878	KNOB(POW) [BLK]			
	28324879	KNOB(POW) [SIL]			
A805	28324872	KNOB(SP) [BLK]			
	28324875	KNOB(SP) [SIL]			
A806	28324873A	KNOB(TONE) [BLK]			

NOTE: THE COMPONENTS IDENTIFIED BY MARK △ ARE CRITICAL FOR RISK OF FIRE AND ELECTRIC SHOCK. REPLACE ONLY WITH PART NUMBER SPECIFIED.

CHASSIS-EXPLODED VIEW

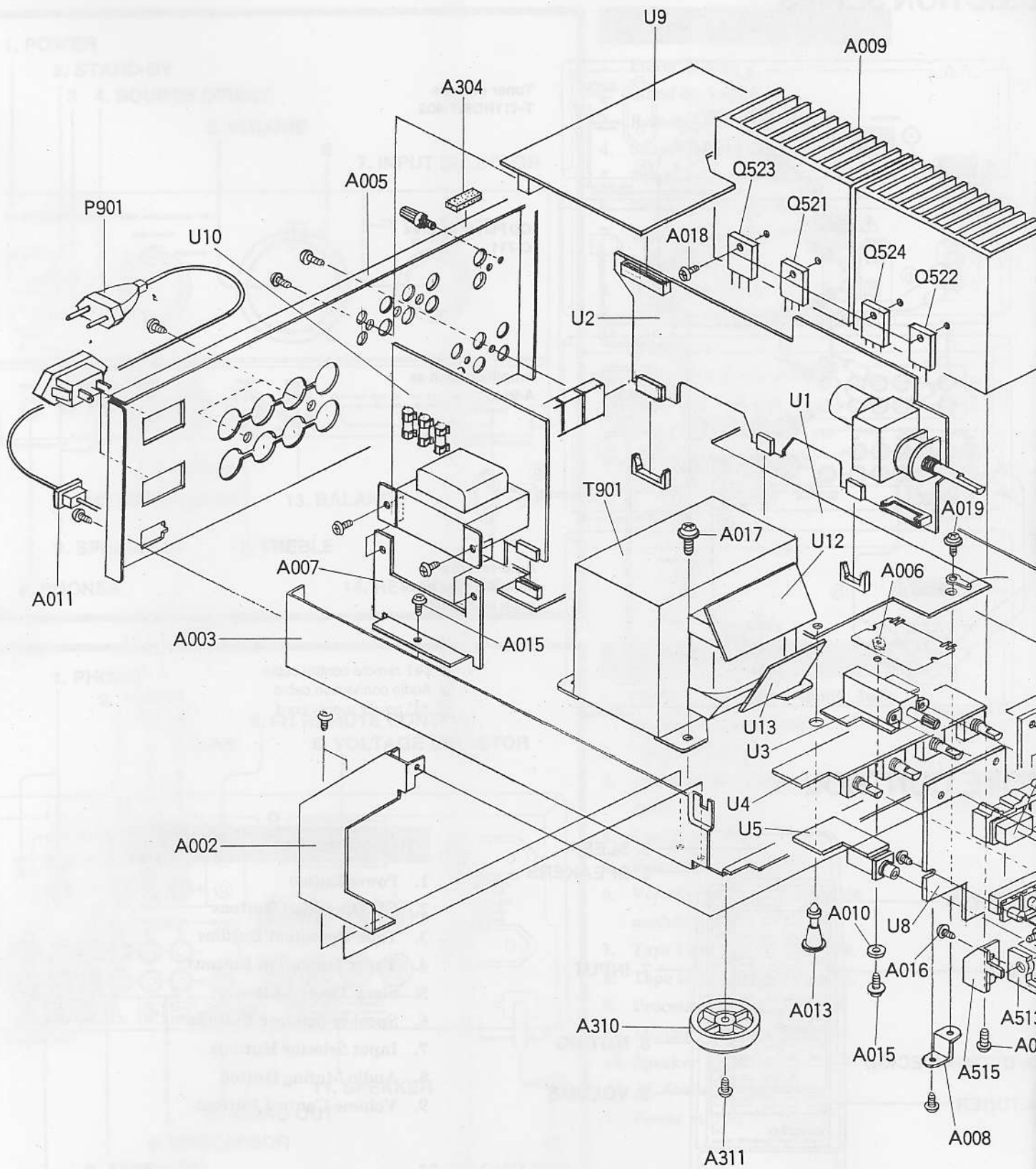

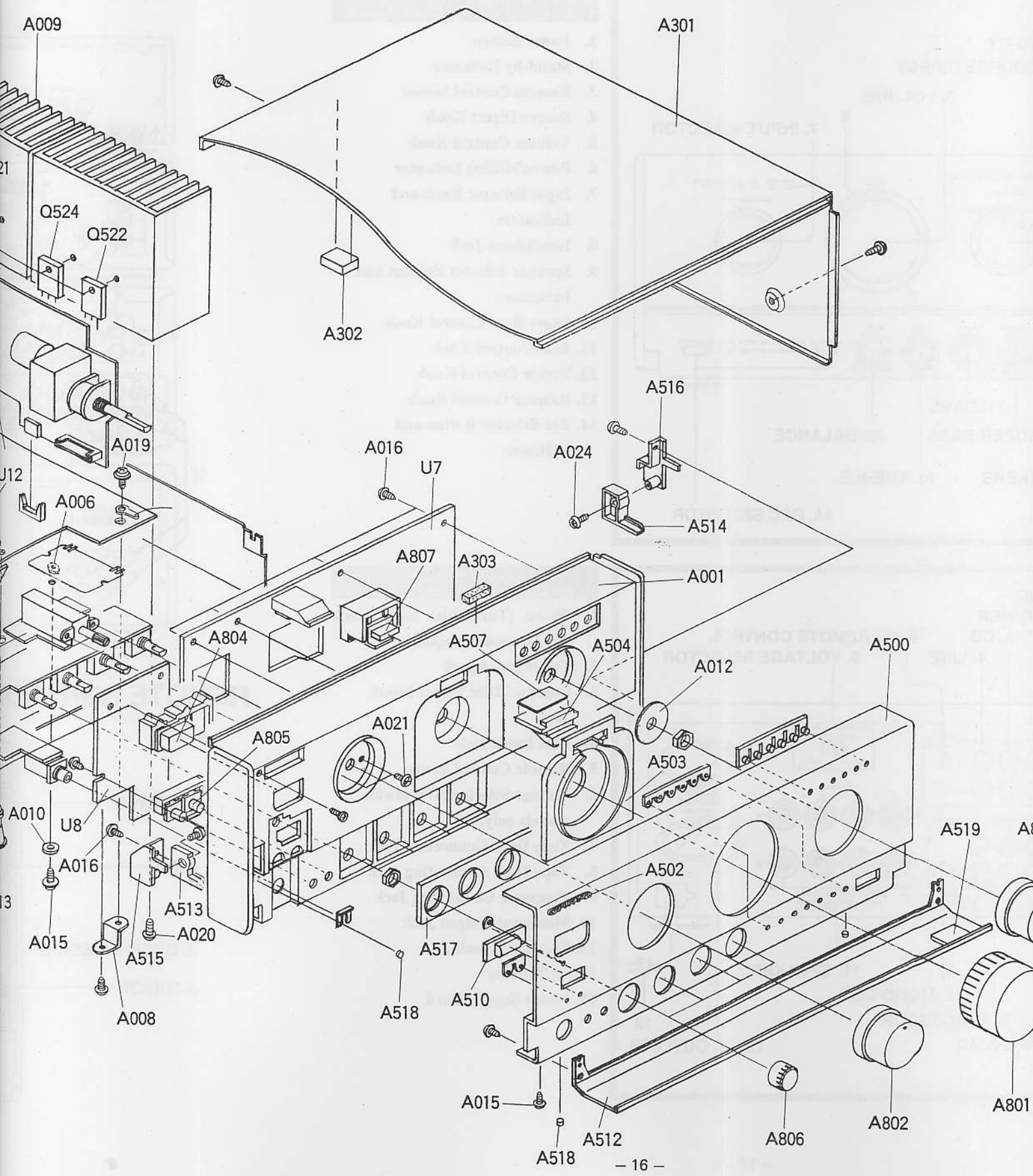

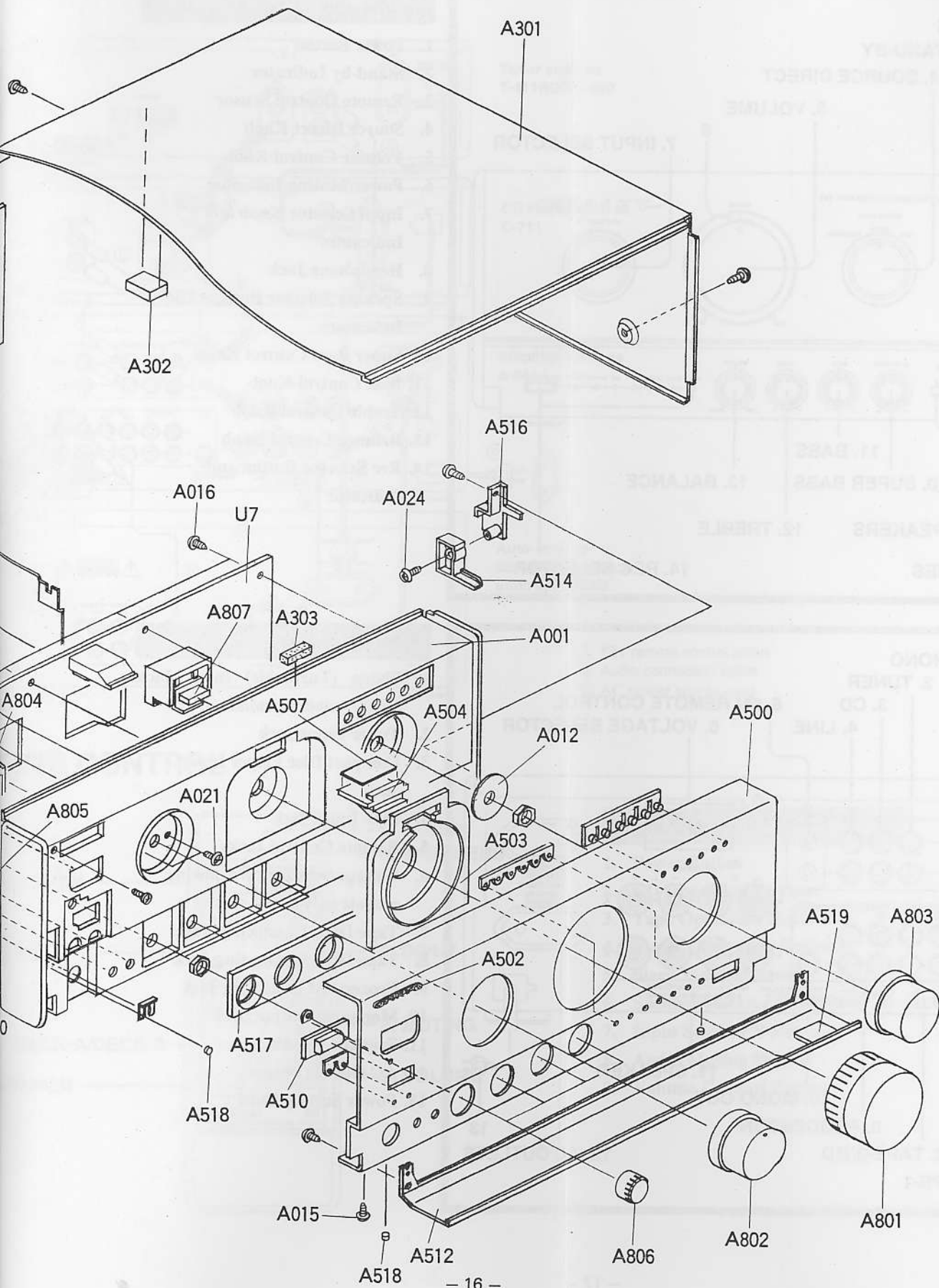

FRONT PANEL / REAR PANEL

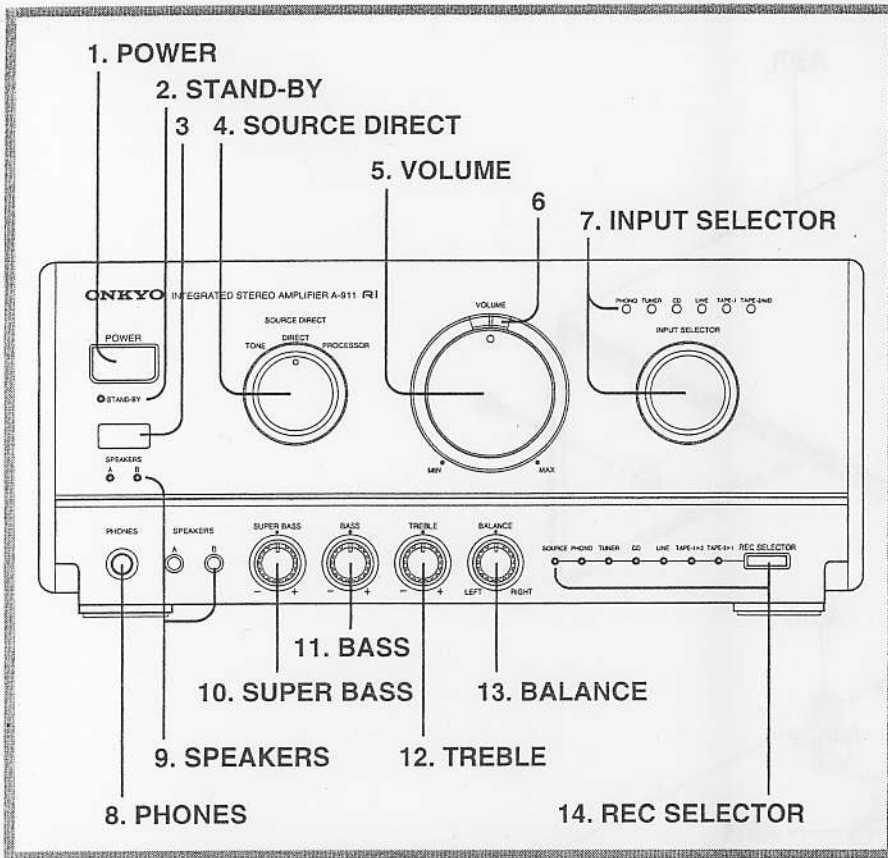
CO
CO

Front panel

1. Power Button
2. Stand-by Indicator
3. Remote Control Sensor
4. Source Direct Knob
5. Volume Control Knob
6. Power/Muting Indicator
7. Input Selector Knob and Indicators
8. Headphone Jack
9. Speaker Selector Buttons and Indicators
10. Super Bass Control Knob
11. Bass Control Knob
12. Treble Control Knob
13. Balance Control Knob
14. Rec Selector Button and Indicator

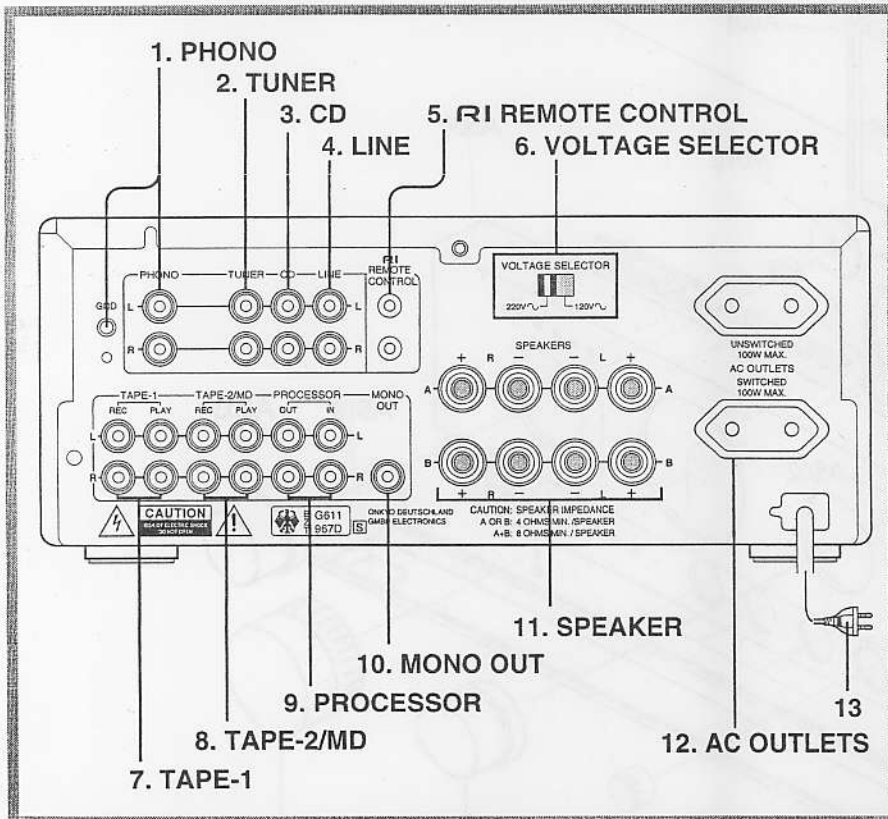

Rear panel

1. Phono (Turntable) Input Jack and Ground Terminal
2. Tuner Input Jack
3. Compact Disc Player Input Jack
4. Line Input Jack
5. Remote Control Jacks
6. Voltage Selector (Worldwide models only)
7. Tape Deck Connecting Jack
8. Tape Deck Connecting Jack
9. Processor Connecting Jack
10. Monaural Output Jack
11. Speaker Terminals
12. AC Outlets
13. Power Supply Cord

RE

CONNECTING THE ONKYO LIVERPOOL SEPARATE COLLECTION SERIES

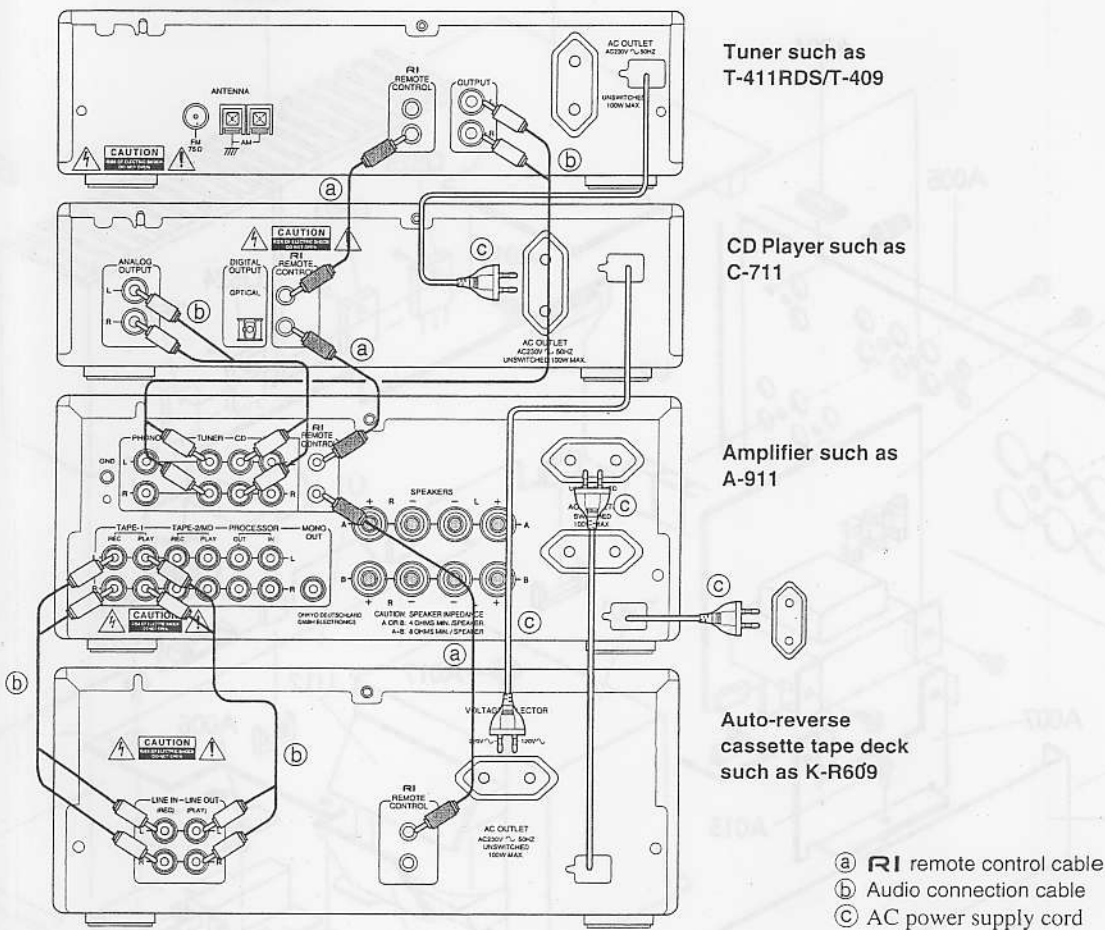

REMOTE CONTROL

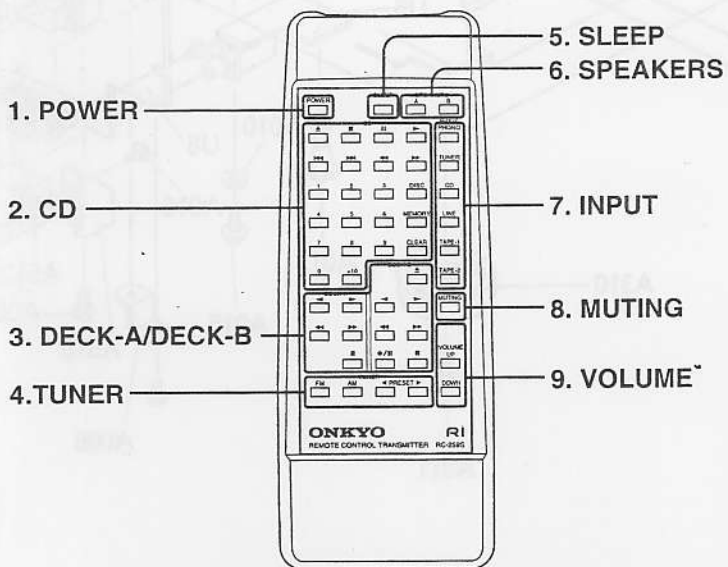

Remote control

1. Power Button
2. CD Operation Buttons
3. Tape Operation Buttons
4. Tuner Operation Buttons
5. Sleep Timer Button
6. Speaker Selector Buttons
7. Input Selector Buttons
8. Audio Muting Button
9. Volume Control Buttons

PRINTED CIRCUIT BOARD VIEW FROM BOTTOM SIDE

NAAF-4809

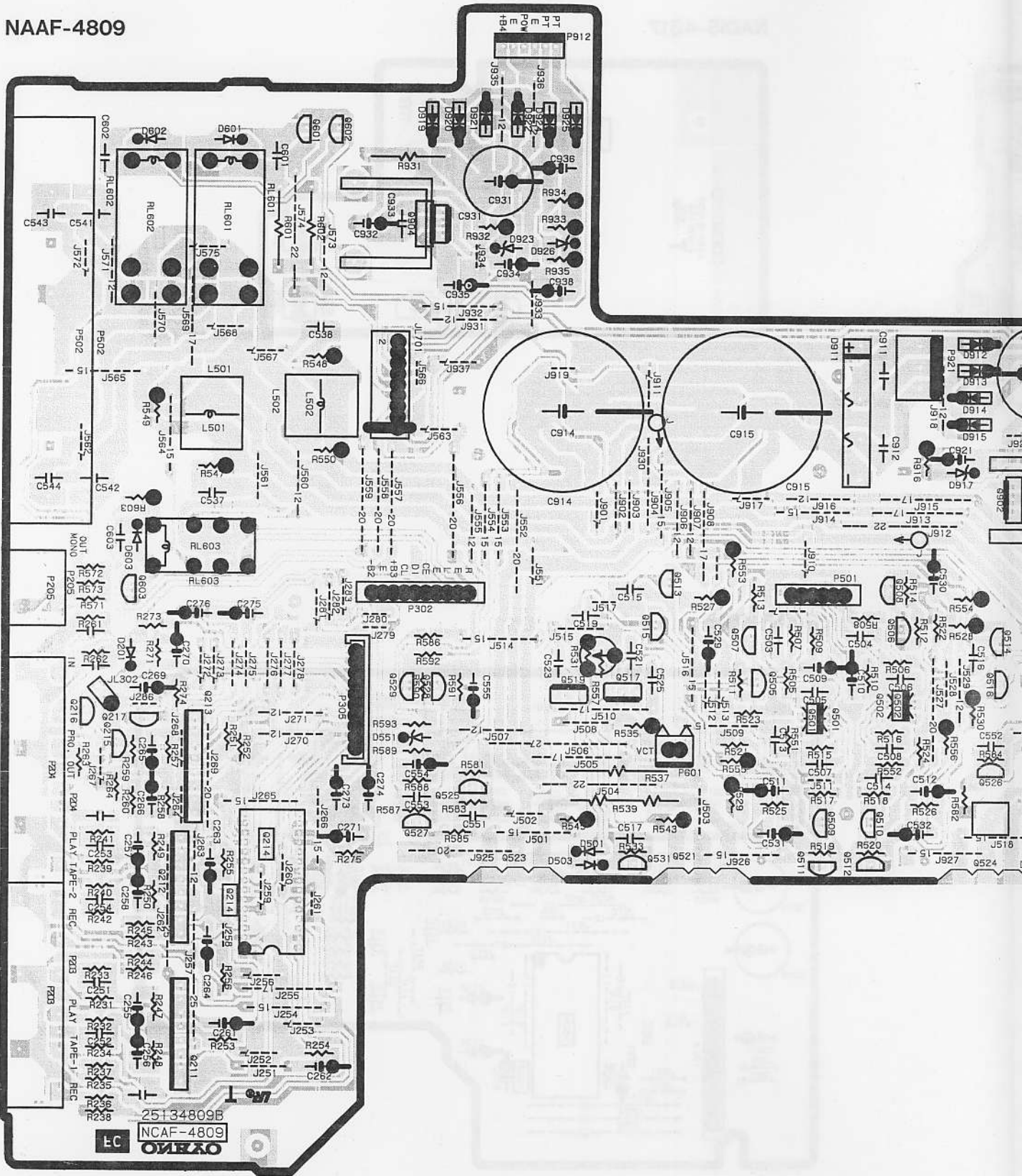

FROM BOTTOM SIDE

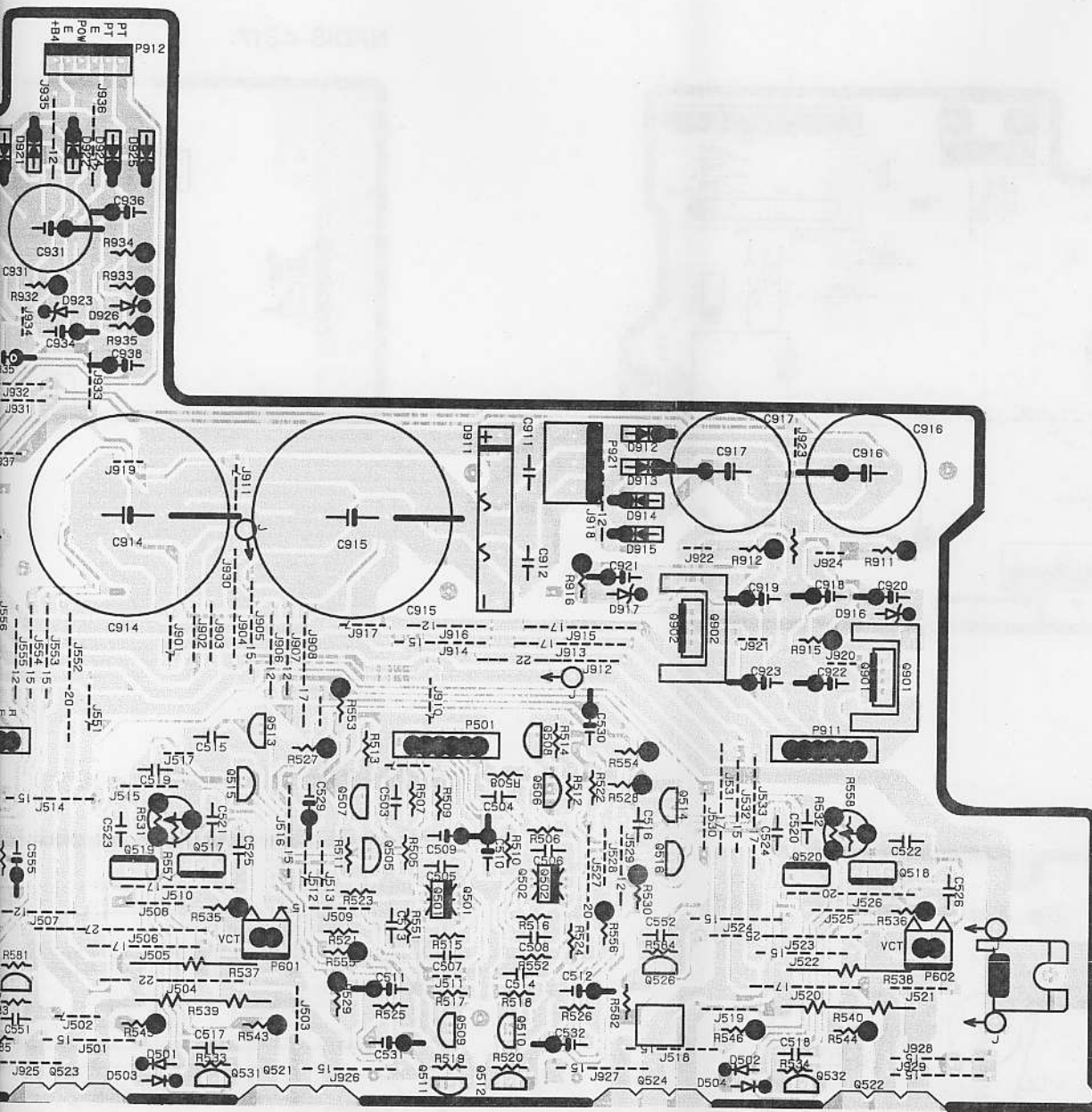

NASW-4811

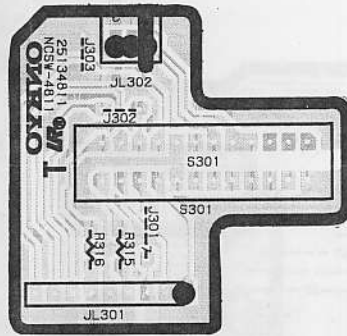

NAETC-4813

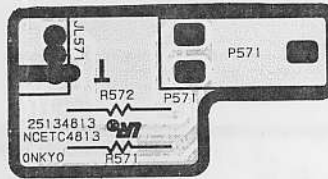

NAETC-4814

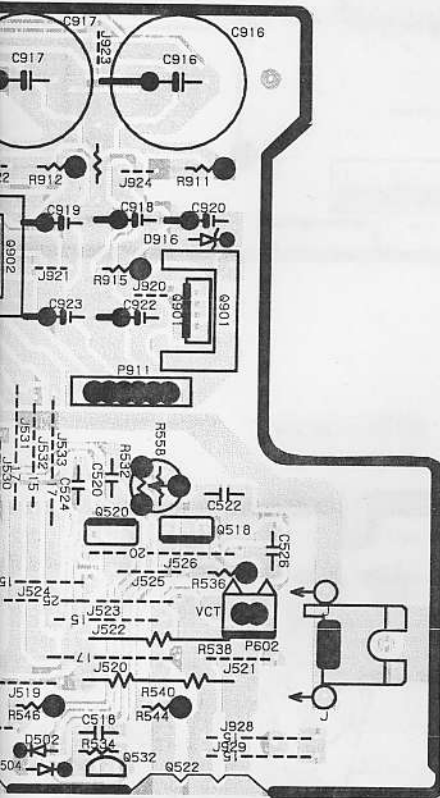

NAAF-4810

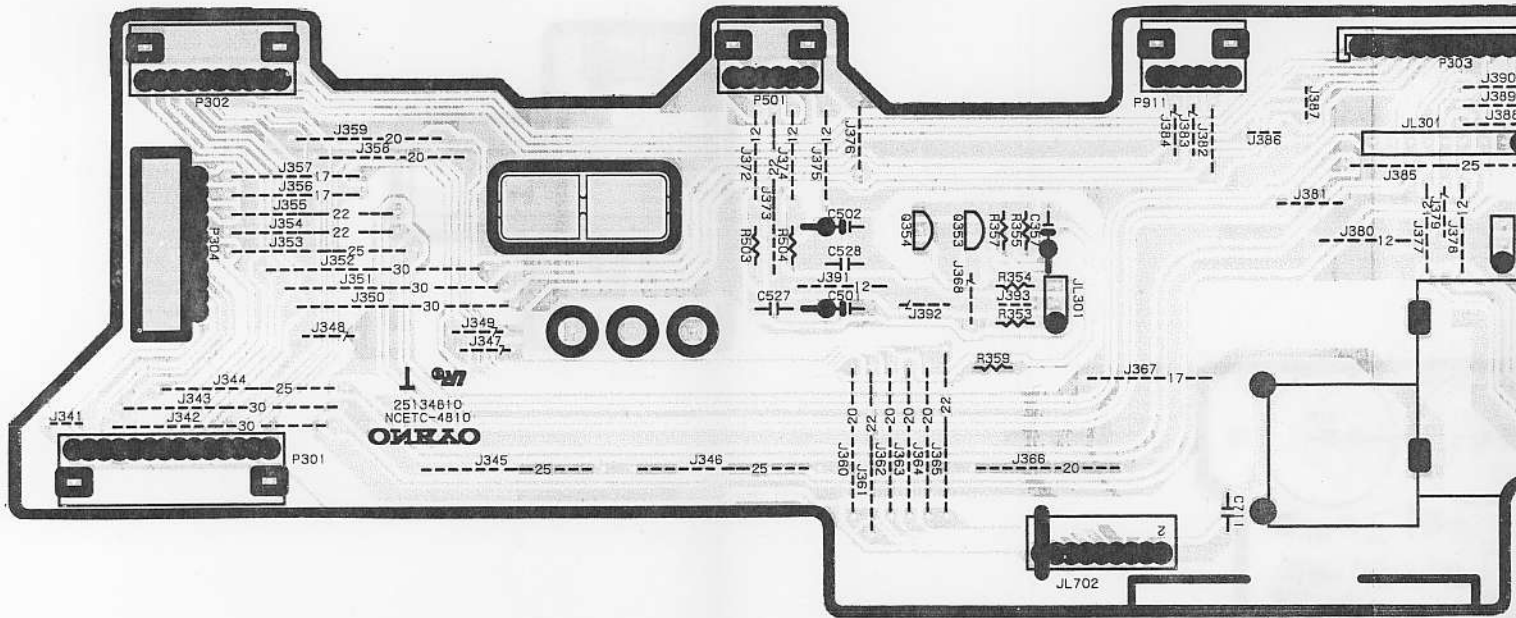

NADG-4816

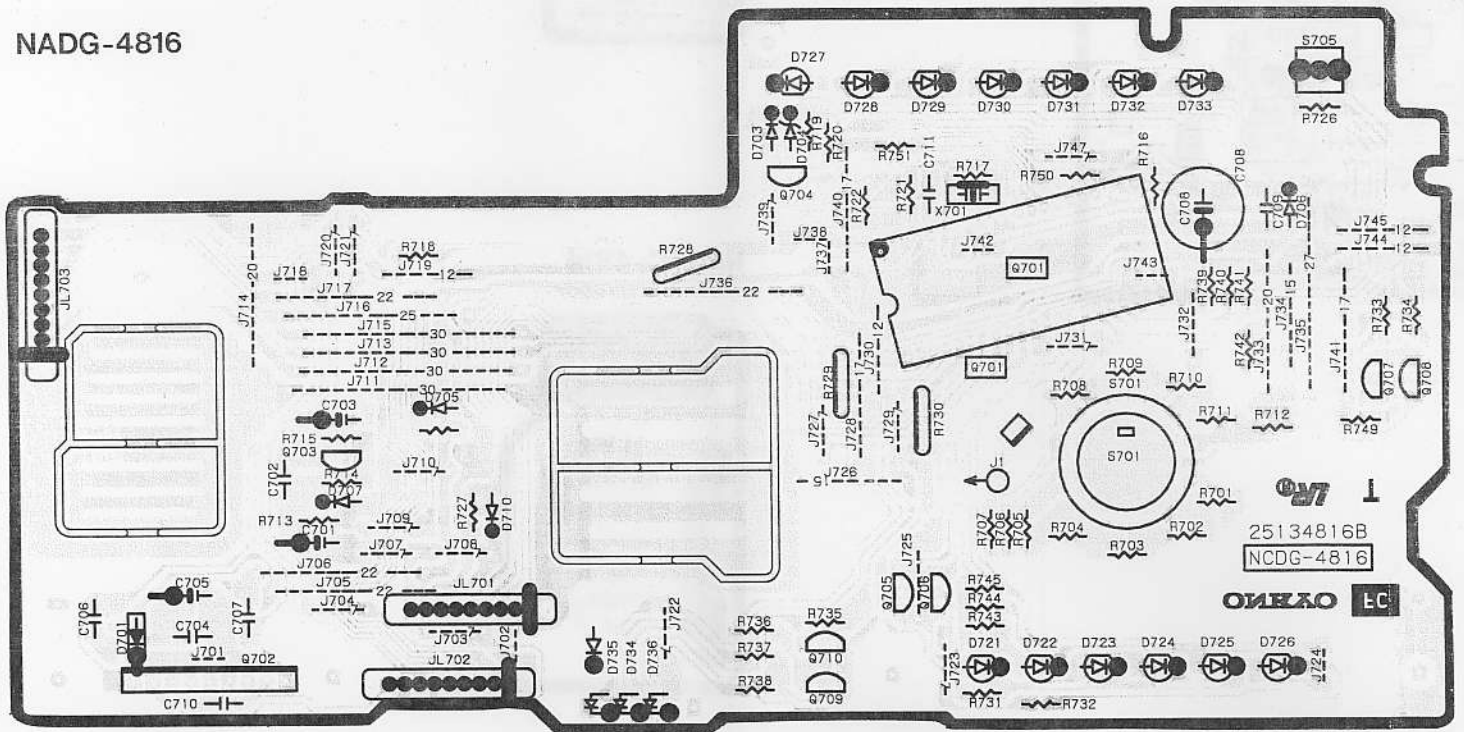

A-911

A-911

NADIS-4817

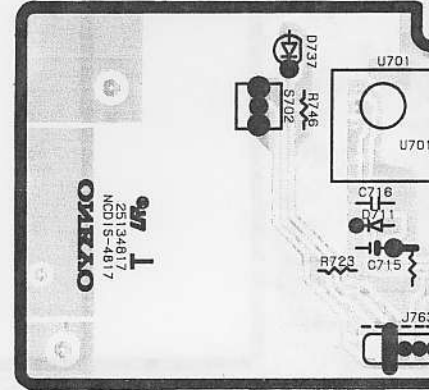
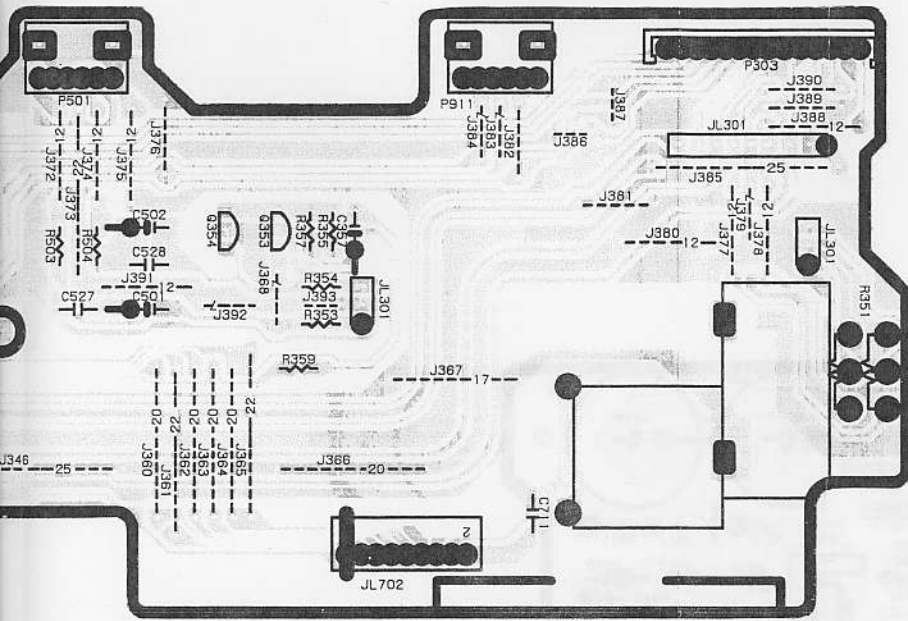

NAAF-4818

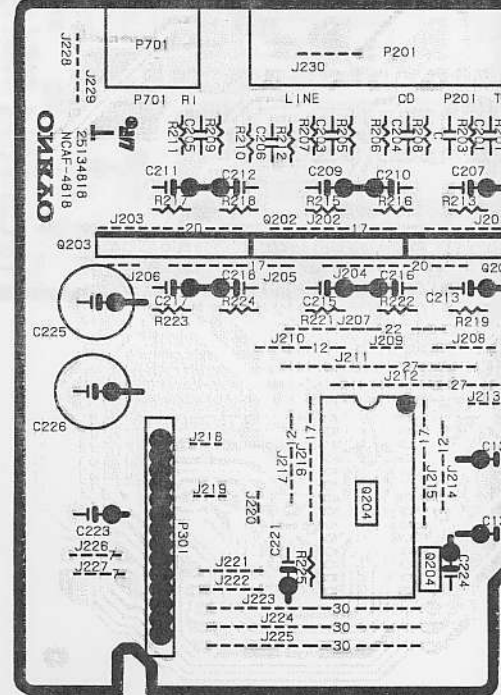
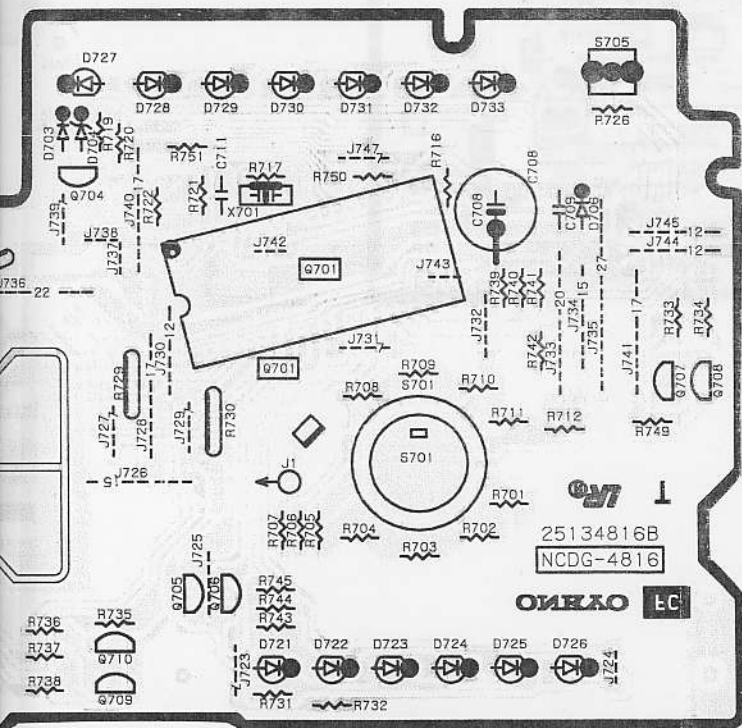

NADIS-4817

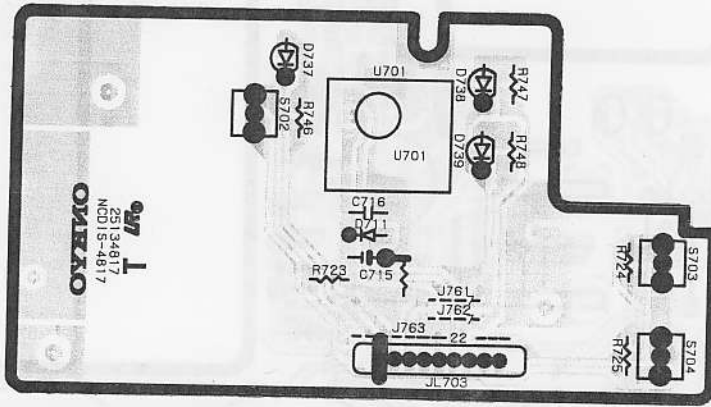

NAAF-4818

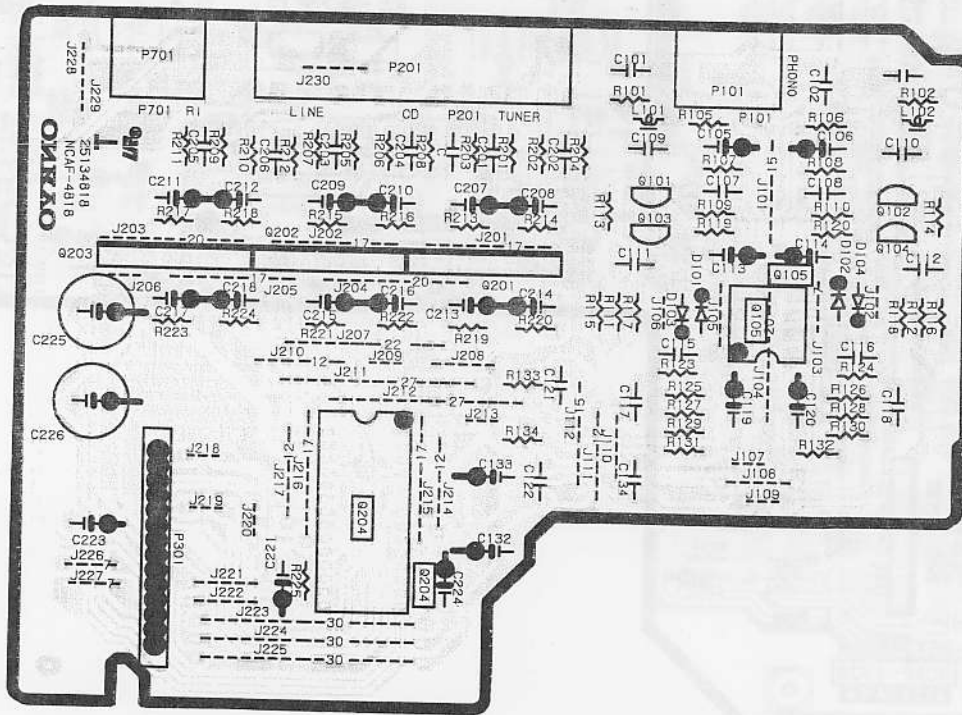

SCHEMATIC DIAGRAM (230V models)

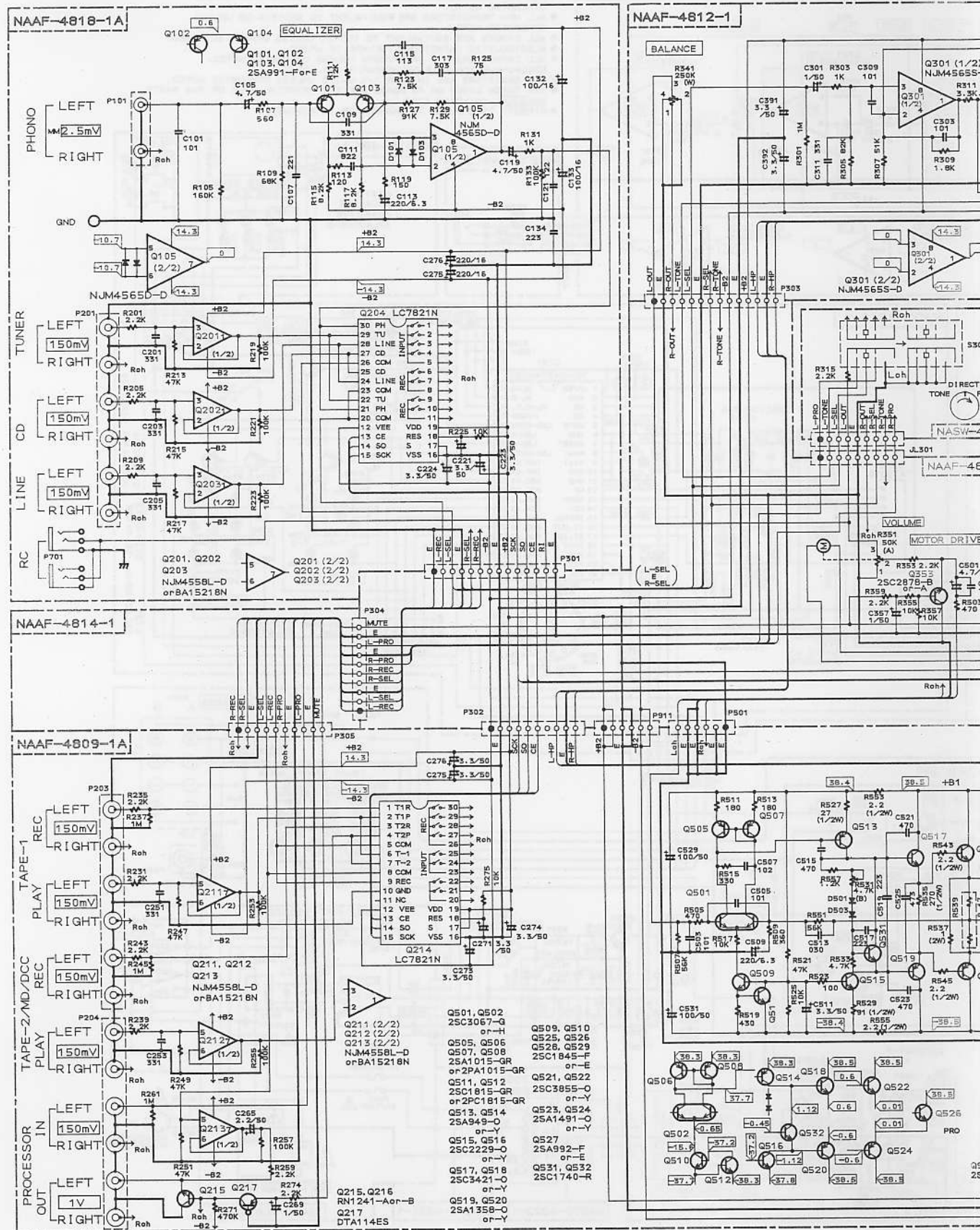

(models)

C D E F

NOTE

- THE COMPONENTS REPLACE ONLY WITH EQUIVALENTS
- VOLTAGE MEASUREMENTS SHOULD BE MADE AT THE POINTS OTHERWISE NOTED
- ALL PNP TRANSISTORS SHOULD BE REVERSE BIAS OTHERWISE NOTED
- ALL DIODES ARE 1N4001 UNLESS OTHERWISE NOTED
- ELECTROLYTIC CAPACITORS ARE 50V UNLESS OTHERWISE NOTED
- ALL CAPACITORS ARE EX01030-3P, 330-100P UNLESS OTHERWISE NOTED
- ALL RESISTORS ARE 1% TOLERANCE UNLESS OTHERWISE NOTED
- THE THICK LINES ARE FOR PRINTING PURPOSES
- EX01030-3P, 330-100P UNLESS OTHERWISE NOTED
- CIRCUIT IS SUBSTANTIAL

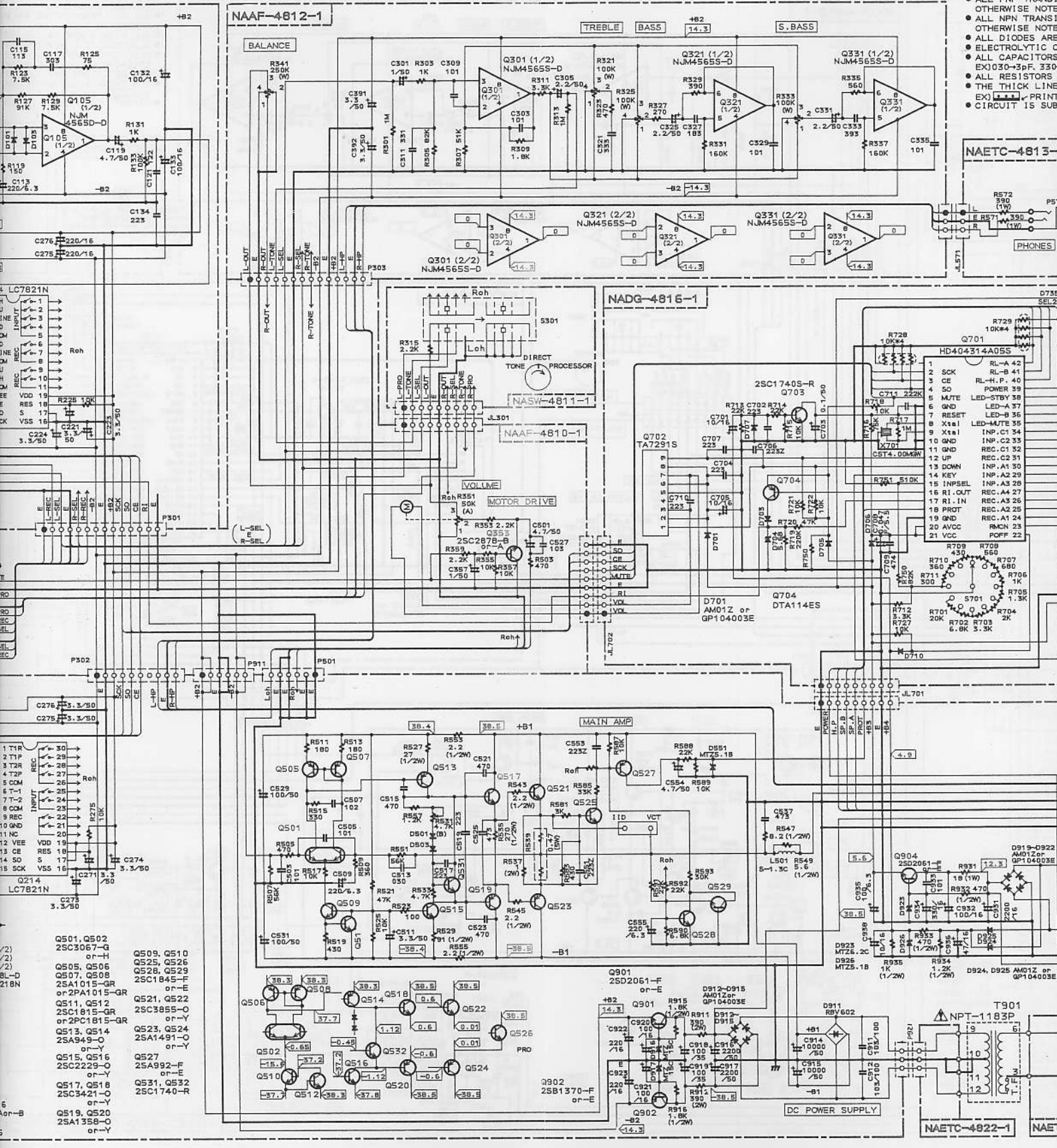

NAETC-4813-1

NAETC-4822-1

- Q501, Q502 2SC3067-G or-H
- Q505, Q506 Q507, Q508 2SA1015-GR or-2PA1015-GR
- Q511, Q512 2SC1815-GR or-2PC1815-GR
- Q513, Q514 2SA949-O or-Y
- Q515, Q516 2SC2229-O or-Y
- Q517, Q518 2SC3421-O or-Y
- Q519, Q520 2SA1358-O or-Y
- Q509, Q510 Q525, Q526 Q528, Q529 2SC1845-F or-E
- Q521, Q522 2SC3855-O or-Y
- Q523, Q524 2SA1491-O or-Y
- Q527 2SA992-F or-E
- Q531, Q532 2SC1740-R or-E
- Q509, Q510 Q525, Q526 Q528, Q529 2SC1845-F or-E
- Q521, Q522 2SC3855-O or-Y
- Q523, Q524 2SA1491-O or-Y
- Q527 2SA992-F or-E
- Q531, Q532 2SC1740-R or-E

E

F

G

NOTE

- THE COMPONENTS IDENTIFIED BY MARK Δ ARE CRITICAL FOR SAFETY. REPLACE ONLY WITH PART NUMBER SPECIFIED.
- VOLTAGE (MEASURED WITH VOLTMETER) C IS DC VOLTAGE. (NO INPUT SIGNAL)
- ALL PNP TRANSISTORS ARE EQUIVALENT TO 2SA1015-GR UNLESS OTHERWISE NOTED.
- ALL NPN TRANSISTORS ARE EQUIVALENT TO 2SC1815-GR UNLESS OTHERWISE NOTED.
- ALL DIODES ARE EQUIVALENT TO 1SS133 UNLESS OTHERWISE NOTED.
- ELECTROLYTIC CAPACITORS (Ψ) ARE IN μ F/WV.
- ALL CAPACITORS ARE IN pF/50WV UNLESS OTHERWISE NOTED.
- EX) 0.030- \pm 3pF, 330- \pm 3pF, 331- \pm 330pF, 333- \pm 0.033 μ F
- ALL RESISTORS ARE IN OHMS 1/4 WATTS UNLESS OTHERWISE NOTED.
- THE THICK LINES ON PC BOARD ARE THE PRINTING SIDE OF THE PARTS.
- EX) Δ PRINTING SIDE
- CIRCUIT IS SUBJECT TO CHANGE FOR IMPROVEMENT.

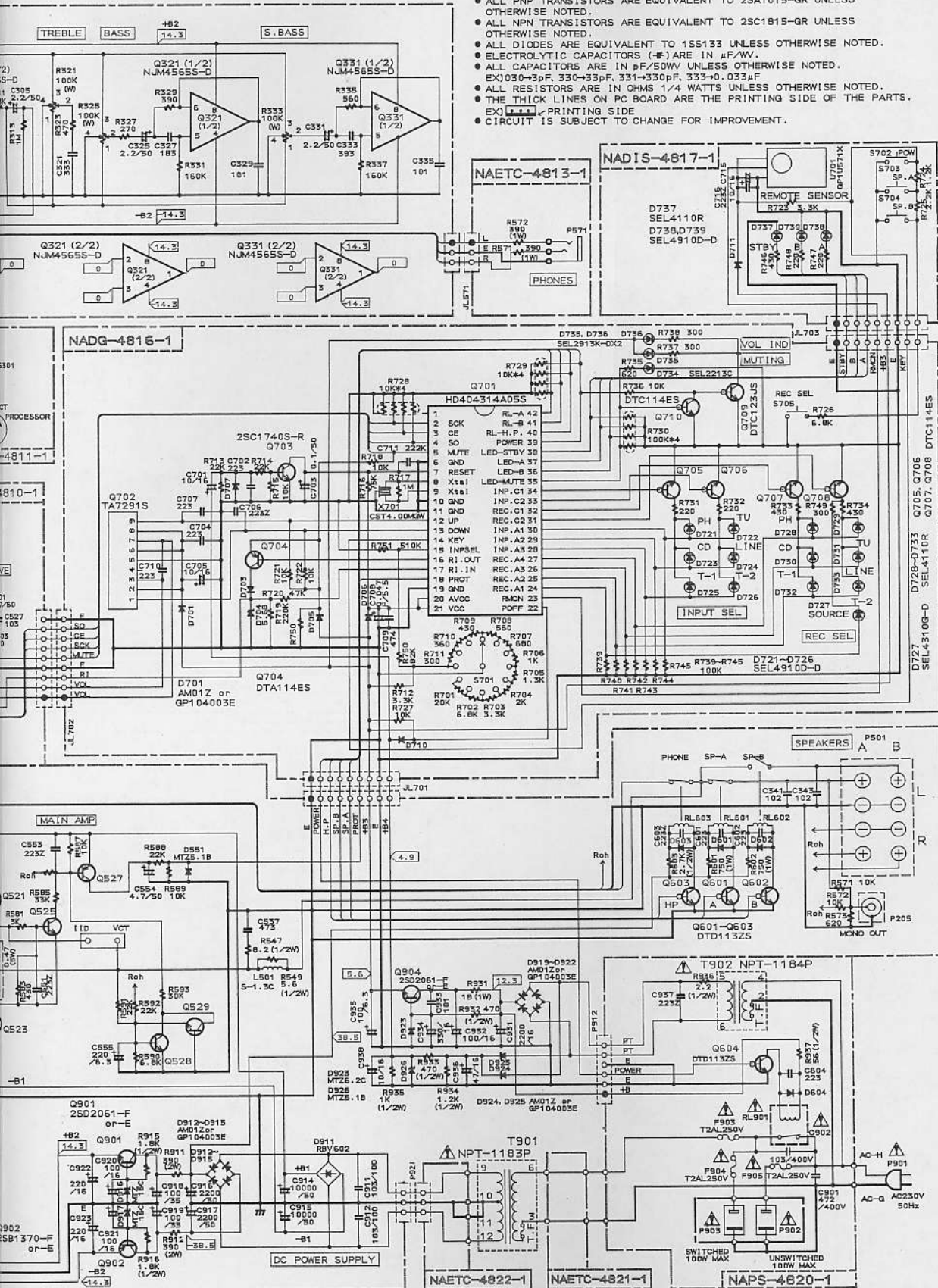

SCHEMATIC DIAGRAM (120V/220V models)

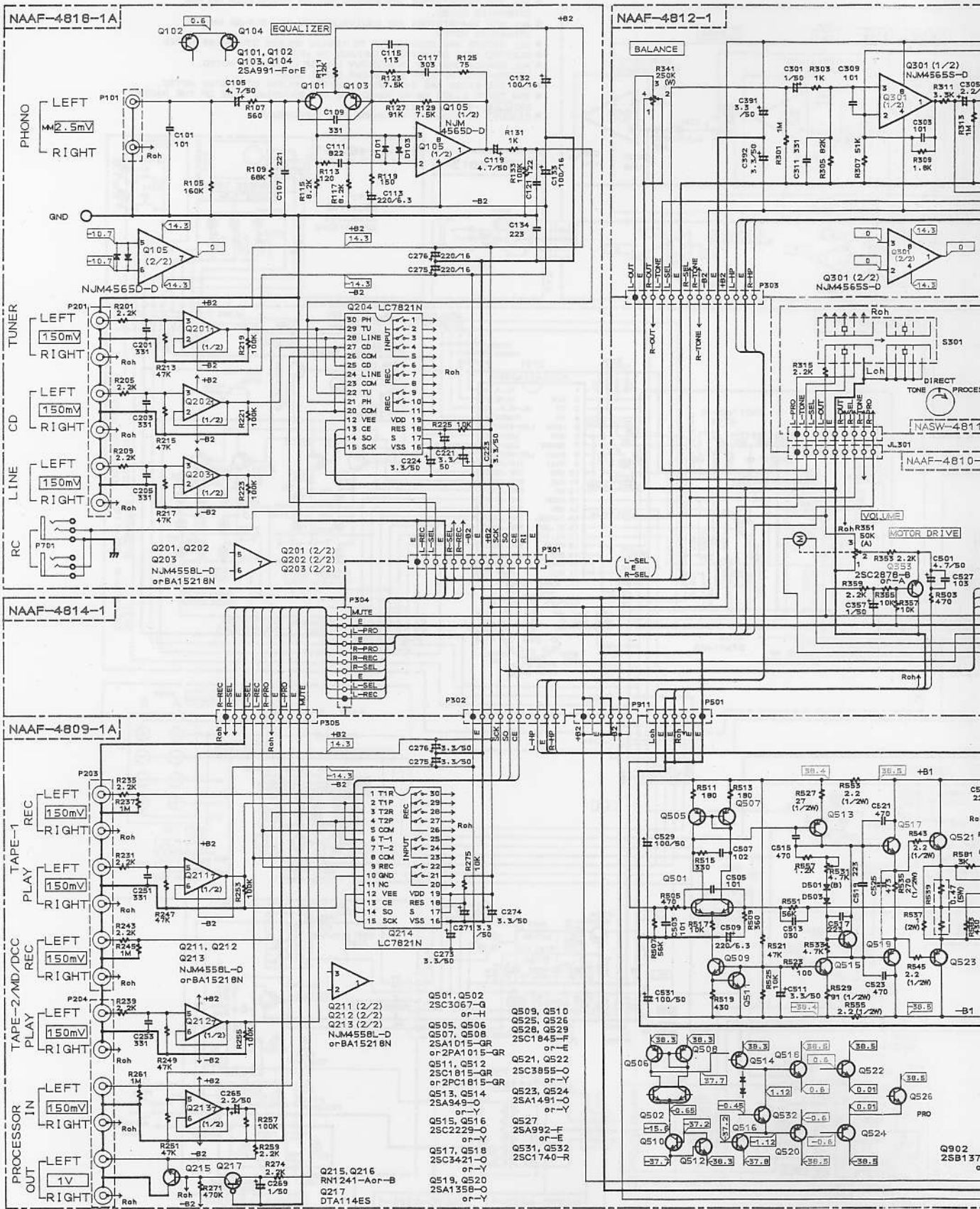

1

2

3

4

5

NAAF-4818-1A

NAAF-4812-1

NAAF-4814-1

NAAF-4809-1A

- Q201, Q202 NJM4558-D or BA15218N
- Q203 (2/2)
- Q202 (2/2)
- Q203 (2/2)
- Q211, Q212, Q213 NJM4558-D or BA15218N
- Q211 (2/2)
- Q212 (2/2)
- Q213 (2/2)
- Q215, Q216 RN1241-A or -B
- Q217 DTA114ES
- Q501, Q502 25C3067-Q or -H
- Q509, Q510 Q525, Q526 Q528, Q529 25C1845-F or -E
- Q505, Q506 25A1015-GR or -P
- Q507, Q508 25A1015-GR or -P
- Q511, Q512 25C3855-O or -Y
- Q513, Q514 25A1815-GR or -Y
- Q515, Q516 25C2229-O or -Y
- Q517, Q518 25C3421-O or -Y
- Q519, Q520 25A1358-O or -Y
- Q503, Q504 25C1845-F or -E
- Q505, Q506 25A1015-GR or -P
- Q507, Q508 25A1015-GR or -P
- Q511, Q512 25C3855-O or -Y
- Q513, Q514 25A1815-GR or -Y
- Q515, Q516 25C2229-O or -Y
- Q517, Q518 25C3421-O or -Y
- Q519, Q520 25A1358-O or -Y
- Q509, Q510 Q525, Q526 Q528, Q529 25C1845-F or -E
- Q521, Q522 25C3855-O or -Y
- Q523, Q524 25A1491-O or -Y
- Q527 25A992-F or -E
- Q531, Q532 25C1740-R
- Q505, Q506 25A1015-GR or -P
- Q507, Q508 25A1015-GR or -P
- Q511, Q512 25C3855-O or -Y
- Q513, Q514 25A1815-GR or -Y
- Q515, Q516 25C2229-O or -Y
- Q517, Q518 25C3421-O or -Y
- Q519, Q520 25A1358-O or -Y
- Q509, Q510 Q525, Q526 Q528, Q529 25C1845-F or -E
- Q521, Q522 25C3855-O or -Y
- Q523, Q524 25A1491-O or -Y
- Q527 25A992-F or -E
- Q531, Q532 25C1740-R
- Q505, Q506 25A1015-GR or -P
- Q507, Q508 25A1015-GR or -P
- Q511, Q512 25C3855-O or -Y
- Q513, Q514 25A1815-GR or -Y
- Q515, Q516 25C2229-O or -Y
- Q517, Q518 25C3421-O or -Y
- Q519, Q520 25A1358-O or -Y
- Q509, Q510 Q525, Q526 Q528, Q529 25C1845-F or -E
- Q521, Q522 25C3855-O or -Y
- Q523, Q524 25A1491-O or -Y
- Q527 25A992-F or -E
- Q531, Q532 25C1740-R

Q902 25B137

20V models)

NOTE

- THE COMPONENTS IDENTIFIED BY A CIRCLE SHOULD BE REPLACED ONLY WITH EQUIVALENTS.
- ALL PNP TRANSISTORS SHOULD BE IDENTIFIED OTHERWISE NOTED.
- ALL NPN TRANSISTORS SHOULD BE IDENTIFIED OTHERWISE NOTED.
- ALL DIODES ARE EQUIVALENTS.
- ELECTROLYTIC CAPACITORS ARE IDENTIFIED BY A CIRCLE.
- ALL CAPACITORS ARE IDENTIFIED BY A CIRCLE EXCEPT 33P, 330-33PF.
- ALL RESISTORS ARE IDENTIFIED BY A CIRCLE EXCEPT 10K, 100K, 1M, 10M, 100M, 1G.
- THE THICK LINES ON THIS PRINTING INDICATE THE CIRCUIT IS SUBJECT TO CHANGE.

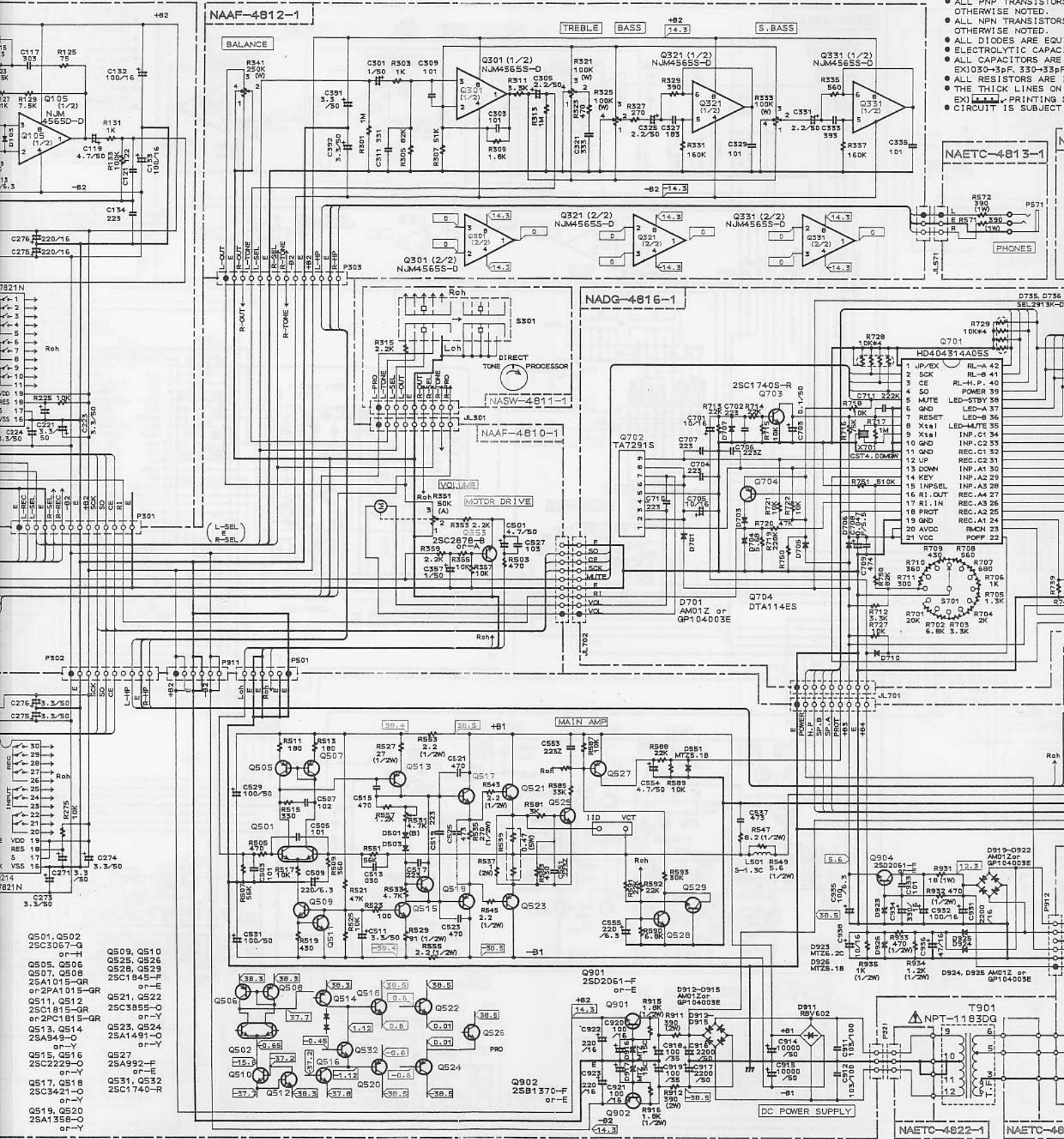

- Q501, Q502 2SC3067-G or H
- Q505, Q506 Q525, Q526
- Q507, Q508 2SC1845-P or-E
- 2SA1015-GR Q521, Q522 or-2PA1015-GR
- Q511, Q512 2SC1815-GR or-Y
- or-2PC1815-GR
- Q513, Q514 Q523, Q524 2SA949-O or-Y
- Q527 2SA992-F
- Q515, Q516 2SC3955-O or-Y
- Q517, Q518 Q531, Q532 2SC3421-O or-Y
- Q519, Q520 2SA1358-O or-Y
- Q509, Q510 Q525, Q526
- Q525, Q526 2SC3955-O or-Y
- Q521, Q522 or-2PA1015-GR
- Q523, Q524 2SA1491-O or-Y
- Q527 2SA992-F
- Q531, Q532 2SC1740-R
- Q526 PRO
- Q524

NOTE

- THE COMPONENTS IDENTIFIED BY MARK Δ ARE CRITICAL FOR SAFETY. REPLACE ONLY WITH PART NUMBER SPECIFIED.
- VOLTAGE (MEASURED WITH VOLTMETER) C IS DC VOLTAGE, (NO INPUT SIGNAL).
- ALL PNP TRANSISTORS ARE EQUIVALENT TO 2SA1015-GR UNLESS OTHERWISE NOTED.
- ALL NPN TRANSISTORS ARE EQUIVALENT TO 2SC1815-GR UNLESS OTHERWISE NOTED.
- ALL DIODES ARE EQUIVALENT TO 15S133 UNLESS OTHERWISE NOTED.
- ELECTROLYTIC CAPACITORS (Ψ) ARE IN μ F/WV.
- ALL CAPACITORS ARE IN pF/50WV UNLESS OTHERWISE NOTED.
- EX) 030-33pF, 330-33pF, 331-330pF, 333-0.033 μ F
- ALL RESISTORS ARE IN OHMS 1/4 WATTS UNLESS OTHERWISE NOTED.
- THE THICK LINES ON PC BOARD ARE THE PRINTING SIDE OF THE PARTS.
- EX) \square PRINTING SIDE
- CIRCUIT IS SUBJECT TO CHANGE FOR IMPROVEMENT.

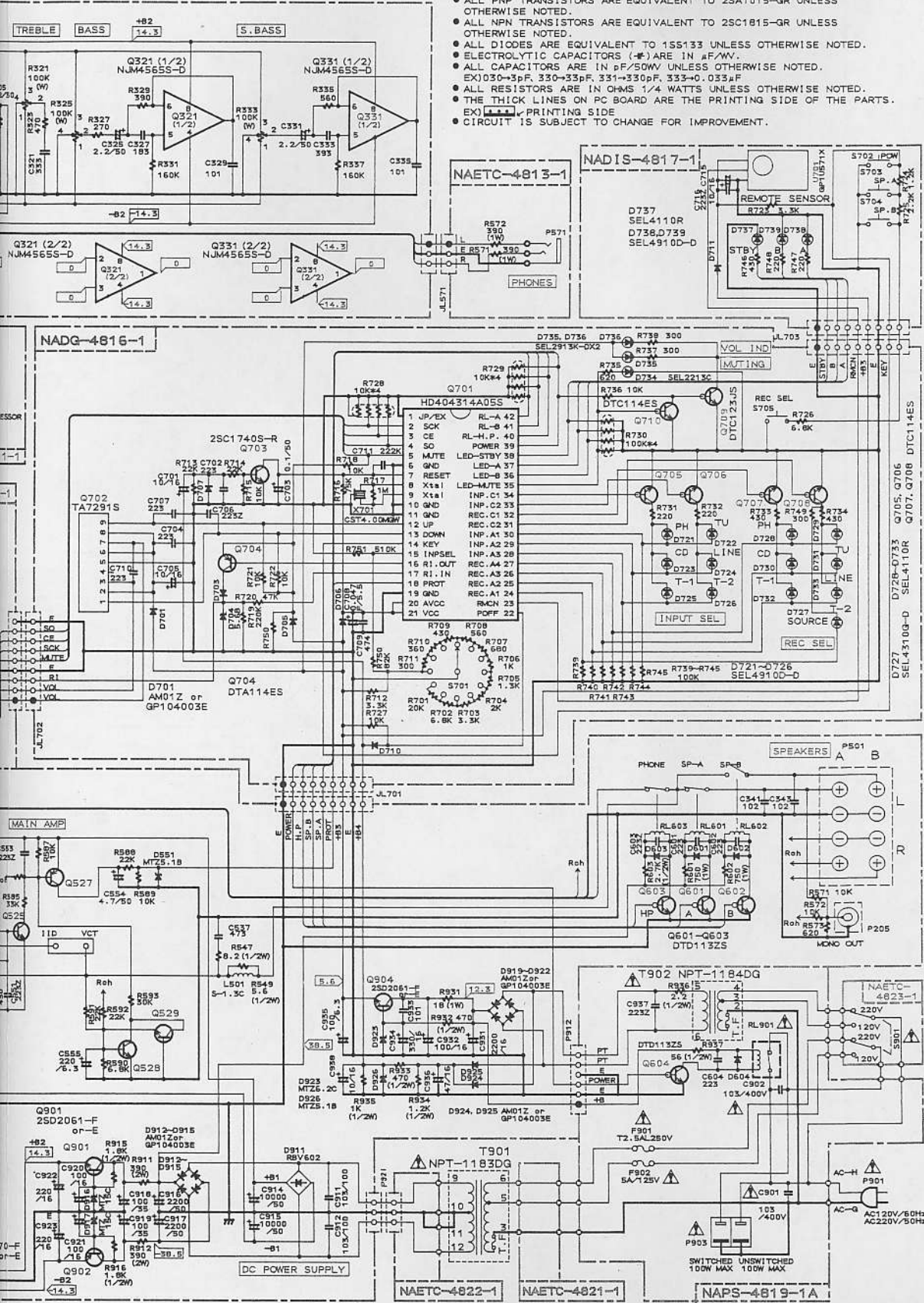

NAPS-4819

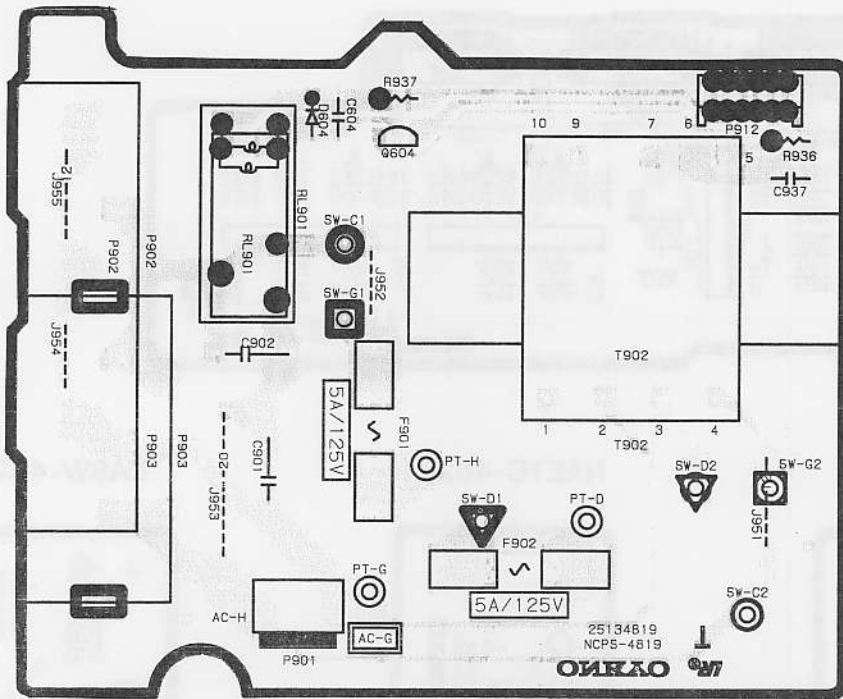

NAPS-4820

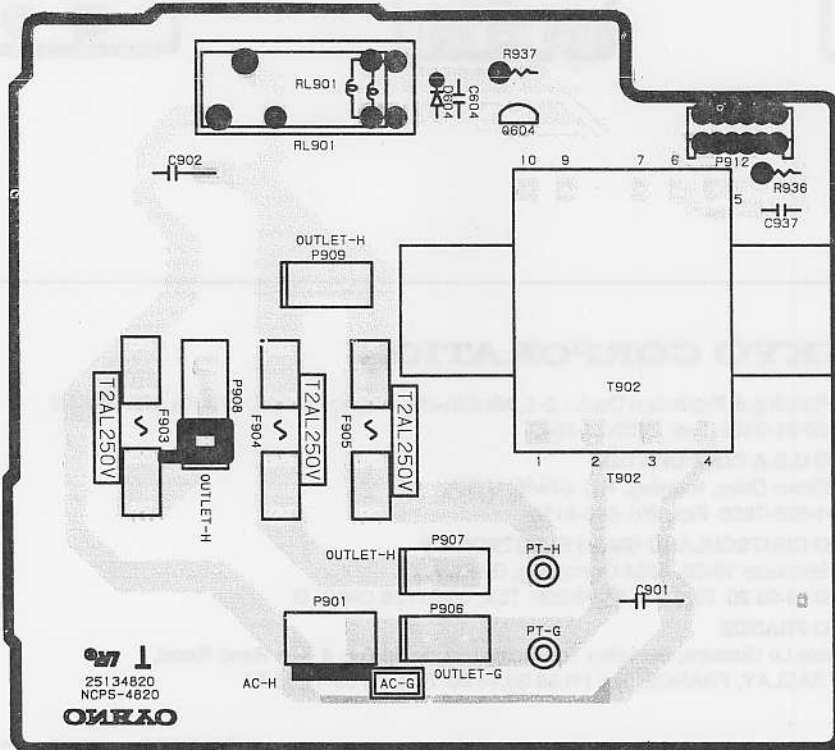

NAAF-4812

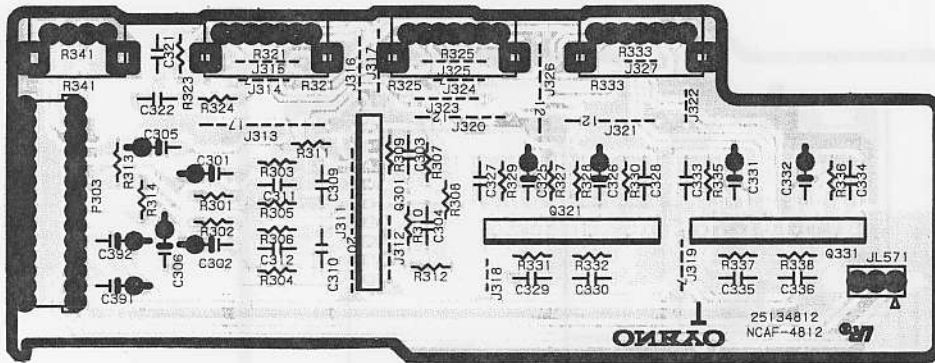

NAETC-4821

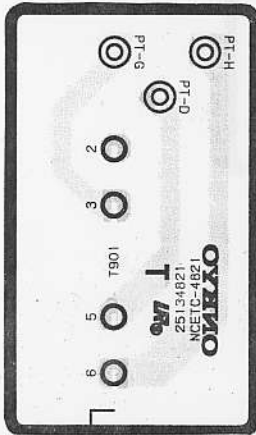

NAETC-4822

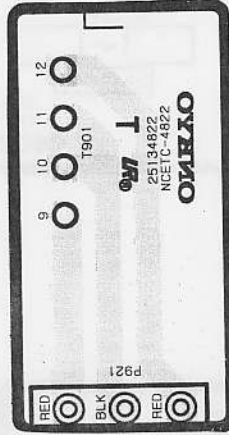

NASW-4823

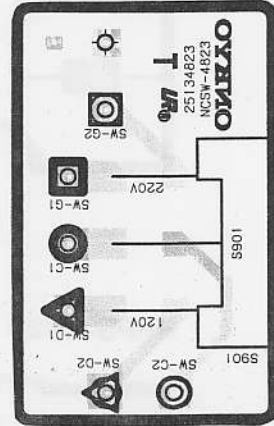

ONKYO CORPORATION

Sales Planning & Promotion Dept. : 2-1, Nisshin-cho, Neyagawa-shi, OSAKA 572, JAPAN
Tel: 0720-31-8133 Fax: 0720-34-1340

ONKYO U.S.A CORPORATION
200 Williams Drive, Ramsey, N.J. 07446, U.S.A.
Tel: 201-825-7950 Fax: 201-825-8150

ONKYO DEUTSCHLAND GMBH ELECTRONICS
Industriestrasse 18-20, 8034 Germering, GERMANY
Tel: 089 84 93 20 Fax: 089 84 93 226 TLX: 05-21726 ONKY D

ONKYO FRANCE
Immeuble Le Diamant, Domaine Technologique de Saclay, 4 Rue René Razel,
91892 SACLAY, FRANCE Tel: (1) 69 33 14 00 Fax: (1) 69 41 35 84

OM3460 N306 Printed in Japan