

ONKYO® SERVICE MANUAL

Integrated Stereo Amplifier MODEL A-9711



Black, Silver and Golden models

BUD	120V AC, 60Hz
BUP/SUP/GUP	230V AC, 50Hz
BUW/GUW	120V/220-230V AC, 50/60Hz

SAFETY-RELATED COMPONENT WARNING!!

COMPONENTS IDENTIFIED BY MARK Δ ON THE SCHEMATIC DIAGRAM AND IN THE PARTS LIST ARE CRITICAL FOR RISK OF FIRE AND ELECTRIC SHOCK. REPLACE THESE COMPONENTS WITH ONKYO PARTS WHOSE PART NUMBERS APPEAR AS SHOWN IN THIS MANUAL.

MAKE LEAKAGE-CURRENT OR RESISTANCE MEASUREMENTS TO DETERMINE THAT EXPOSED PARTS ARE ACCEPTABLY INSULATED FROM THE SUPPLY CIRCUIT BEFORE RETURNING THE APPLIANCE TO THE CUSTOMER.

TABLE OF CONTENTS

Specifications	2
Service Safety Precautions	3
Block Diagram	4
Adjustment Procedures	5
Microprocessor Connection Diagram	6
Terminal Description	7
Chassis Exploded View Parts List	8
Chassis Exploded View	9
Printed Circuit Board View From Bottom Side	11
IC Block Diagrams	16
Schematic Diagrams	17
Printed Circuit Board Parts List	25
Packing Parts List	28



A-9711 A-9711

SCHEMATIC DIAGRAMS MODEL A-9711
(120V model version) (2/2)

LEGEND

- THE COMPONENTS IDENTIFIED BY MARKS ARE CRITICAL FOR SAFETY.
- REPLACE ONLY WITH THE SAME TYPE AND VALUE.
- ALL NEW TRANSISTORS ARE EQUIVALENT TO 2N1819-G WALESS.
- ALL NEW TRANSISTORS ARE EQUIVALENT TO 2N1819-G WALESS.
- ALL DIODES ARE EQUIVALENT TO 1N5711 UNLESS OTHERWISE NOTED.
- ALL CAPACITORS ARE IN MICROFARADS UNLESS OTHERWISE NOTED.
- ALL RESISTORS ARE IN OHMS UNLESS OTHERWISE NOTED.
- ALL DIMENSIONS ARE IN INCHES UNLESS OTHERWISE NOTED.
- DIMENSIONS ARE IN INCHES UNLESS OTHERWISE NOTED.
- DIMENSIONS ARE IN INCHES UNLESS OTHERWISE NOTED.
- DIMENSIONS ARE IN INCHES UNLESS OTHERWISE NOTED.

The schematic diagram illustrates the internal circuitry of Model A-9711, organized into several functional sections:

- LEFT DRIVER AMP (AF-5628-2A):** Located in the upper left, this section includes transistors Q511, Q512, Q513, Q514, Q515, Q516, Q517, Q518, Q519, Q520, Q521, Q522, Q523, Q524, Q525, Q526, Q527, Q528, Q529, Q530, Q531, Q532, Q533, Q534, Q535, Q536, Q537, Q538, Q539, Q540, Q541, Q542, Q543, Q544, Q545, Q546, Q547, Q548, Q549, Q550, Q551, Q552, Q553, Q554, Q555, Q556, Q557, Q558, Q559, Q560, Q561, Q562, Q563, Q564, Q565, Q566, Q567, Q568, Q569, Q570, Q571, Q572, Q573, Q574, Q575, Q576, Q577, Q578, Q579, Q580, Q581, Q582, Q583, Q584, Q585, Q586, Q587, Q588, Q589, Q590, Q591, Q592, Q593, Q594, Q595, Q596, Q597, Q598, Q599, Q600, Q601, Q602, Q603, Q604, Q605, Q606, Q607, Q608, Q609, Q610, Q611, Q612, Q613, Q614, Q615, Q616, Q617, Q618, Q619, Q620, Q621, Q622, Q623, Q624, Q625, Q626, Q627, Q628, Q629, Q630, Q631, Q632, Q633, Q634, Q635, Q636, Q637, Q638, Q639, Q640, Q641, Q642, Q643, Q644, Q645, Q646, Q647, Q648, Q649, Q650, Q651, Q652, Q653, Q654, Q655, Q656, Q657, Q658, Q659, Q660, Q661, Q662, Q663, Q664, Q665, Q666, Q667, Q668, Q669, Q670, Q671, Q672, Q673, Q674, Q675, Q676, Q677, Q678, Q679, Q680, Q681, Q682, Q683, Q684, Q685, Q686, Q687, Q688, Q689, Q690, Q691, Q692, Q693, Q694, Q695, Q696, Q697, Q698, Q699, Q700, Q701, Q702, Q703, Q704, Q705, Q706, Q707, Q708, Q709, Q710, Q711, Q712, Q713, Q714, Q715, Q716, Q717, Q718, Q719, Q720, Q721, Q722, Q723, Q724, Q725, Q726, Q727, Q728, Q729, Q730, Q731, Q732, Q733, Q734, Q735, Q736, Q737, Q738, Q739, Q740, Q741, Q742, Q743, Q744, Q745, Q746, Q747, Q748, Q749, Q750, Q751, Q752, Q753, Q754, Q755, Q756, Q757, Q758, Q759, Q760, Q761, Q762, Q763, Q764, Q765, Q766, Q767, Q768, Q769, Q770, Q771, Q772, Q773, Q774, Q775, Q776, Q777, Q778, Q779, Q780, Q781, Q782, Q783, Q784, Q785, Q786, Q787, Q788, Q789, Q790, Q791, Q792, Q793, Q794, Q795, Q796, Q797, Q798, Q799, Q800, Q801, Q802, Q803, Q804, Q805, Q806, Q807, Q808, Q809, Q810, Q811, Q812, Q813, Q814, Q815, Q816, Q817, Q818, Q819, Q820, Q821, Q822, Q823, Q824, Q825, Q826, Q827, Q828, Q829, Q830, Q831, Q832, Q833, Q834, Q835, Q836, Q837, Q838, Q839, Q840, Q841, Q842, Q843, Q844, Q845, Q846, Q847, Q848, Q849, Q850, Q851, Q852, Q853, Q854, Q855, Q856, Q857, Q858, Q859, Q860, Q861, Q862, Q863, Q864, Q865, Q866, Q867, Q868, Q869, Q870, Q871, Q872, Q873, Q874, Q875, Q876, Q877, Q878, Q879, Q880, Q881, Q882, Q883, Q884, Q885, Q886, Q887, Q888, Q889, Q890, Q891, Q892, Q893, Q894, Q895, Q896, Q897, Q898, Q899, Q900, Q901, Q902, Q903, Q904, Q905, Q906, Q907, Q908, Q909, Q910, Q911, Q912, Q913, Q914, Q915, Q916, Q917, Q918, Q919, Q920, Q921, Q922, Q923, Q924, Q925, Q926, Q927, Q928, Q929, Q930, Q931, Q932, Q933, Q934, Q935, Q936, Q937, Q938, Q939, Q940, Q941, Q942, Q943, Q944, Q945, Q946, Q947, Q948, Q949, Q950, Q951, Q952, Q953, Q954, Q955, Q956, Q957, Q958, Q959, Q960, Q961, Q962, Q963, Q964, Q965, Q966, Q967, Q968, Q969, Q970, Q971, Q972, Q973, Q974, Q975, Q976, Q977, Q978, Q979, Q980, Q981, Q982, Q983, Q984, Q985, Q986, Q987, Q988, Q989, Q990, Q991, Q992, Q993, Q994, Q995, Q996, Q997, Q998, Q999, Q1000.

PRIMARY CONNECTIONS

The primary connections diagram shows the following components and their connections:

- AC OUTLETS UNLIMITED:** Connected to the main power supply.
- POWER:** Connected to the main power supply.
- GROUND:** Connected to the main power supply.
- AC PRV 50 AMP:** Connected to the main power supply.

-20-

-19-

A B C D E F G

SCHEMATIC DIAGRAMS MODEL A-9711 (120V model version) (1/2)

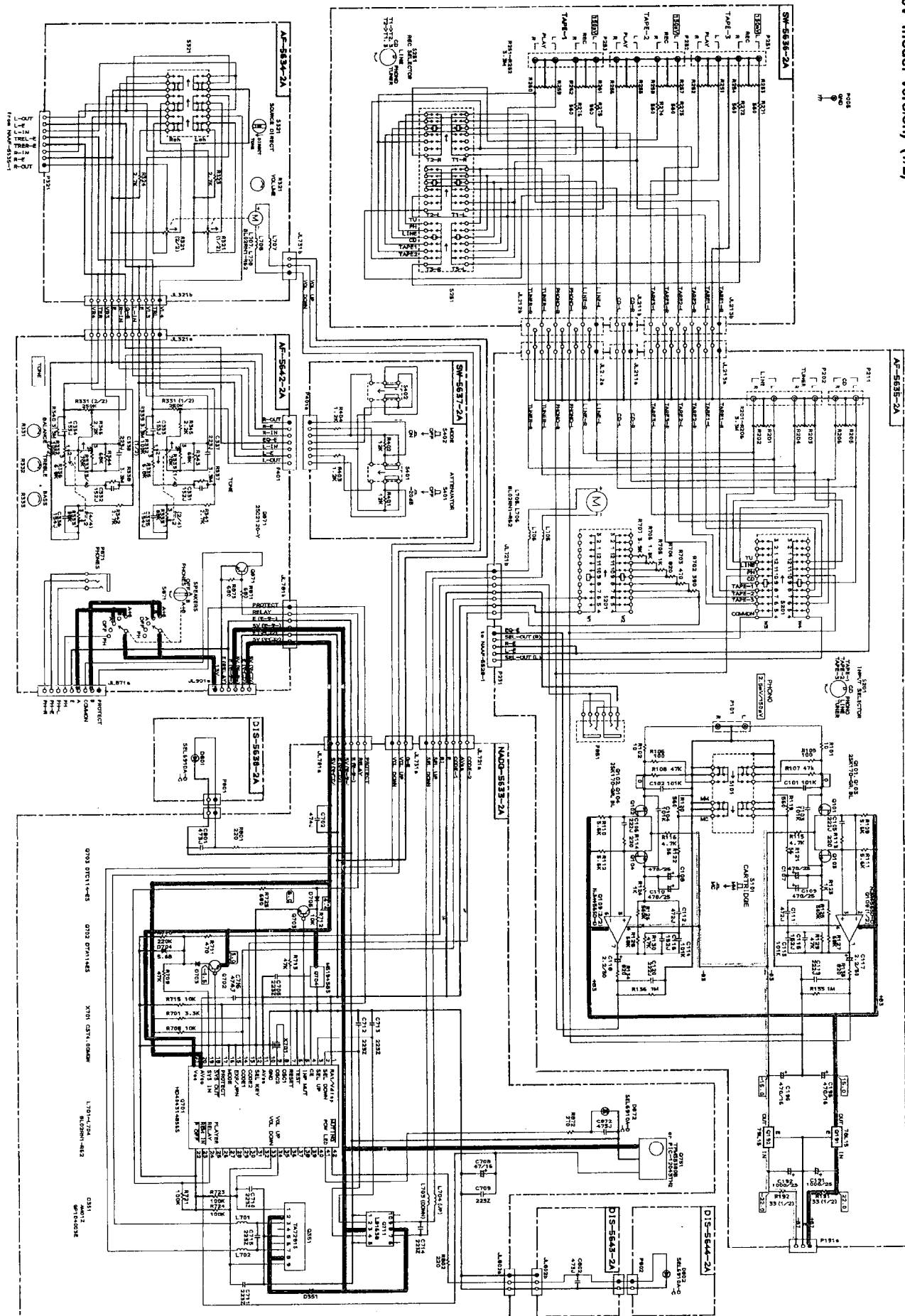

CHASSIS EXPLODED VIEW

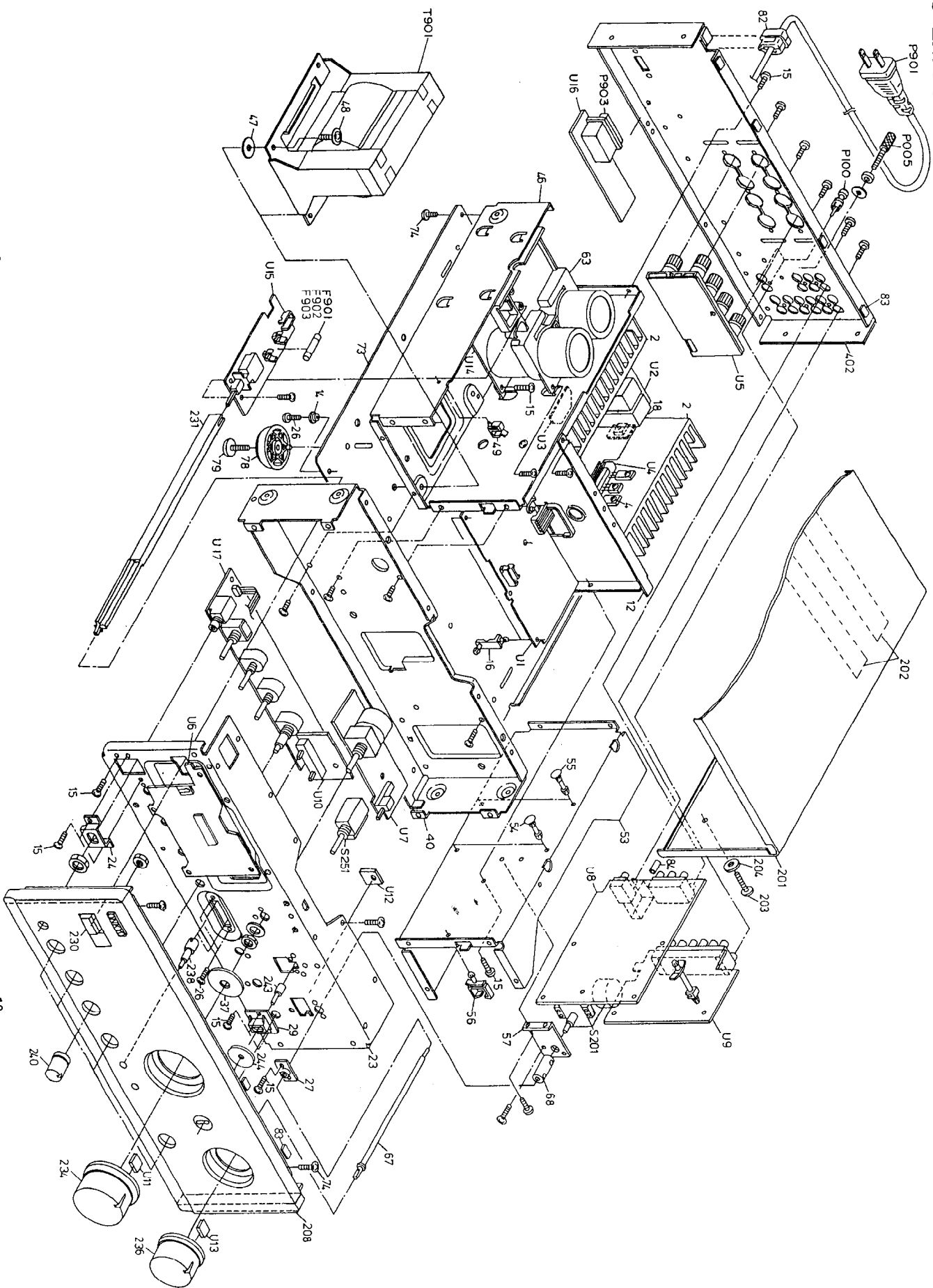

SPECIFICATIONS

Power Output:	80 watts per channel, min. RMS, at 8 ohms, both channels driven from 20 Hz to 20 kHz, with no more than 0.06% Total harmonic distortion. 140 watts per channel, RMS, at 4 ohms, both channels driven at 1 kHz, with no more than 1% Total harmonic distortion. (DIN)
Dynamic Power:	235 watts at 2 ohms 160 watts at 4 ohms 100 watts at 8 ohms
Total Harmonic Distortion:	0.06% at rated power 0.06% at 1 watt output
Intermodulation Distortion:	0.06% at rated power
Damping Factor:	120 at 8 ohms (1 kHz)
Input Sensitivity / Impedance:	U.S.A. & Canadian model: PHONO (MM) 3 mV / 47 kohms PHONO (MC) 300 μ V / 100 ohms CD, TUNER, LINE, TAPE-PLAY (TONE) 300 mV / 25 kohms CD, TUNER, LINE, TAPE-PLAY (SOURCE) 300 mV / 25 kohms
Output Level / Impedance:	TAPE-REC 300 mV / 1.5 kohms (PHONO)
Phono Overload	MM: 1 kHz / 10 kHz at 0.05% THD
(U.S.A. & Canadian model):	100 mV / 480 mV MC: 1 kHz / 10 kHz at 0.1 % THD 10 mV / 48 mV
Frequency Response:	CD, TUNER, LINE, TAPE-PLAY (SOURCE) 2 Hz — 50 kHz (+0, -1 dB) PHONO (MM) (RIAA Deviation) (U.S.A. & Canadian model): ± 0.3 dB, 20 Hz — 20 kHz
Tone Control (Vol -22 dB):	TREBLE (Turnover: 7 kHz) ± 10 dB at 20 kHz BASS (Turnover: 200 Hz) +15 / -6 dB at 20 Hz
High Cut Filter:	TREBLE min. 6 kHz (6 dB / oct.)
Attenuator:	-20 dB
Muting (remote control):	$-\infty$
Signal to Noise Ratio (IHF-A):	U.S.A. & Canadian model: PHONO (MM) 5 mV input 84 dB PHONO (MC) 0.5 mV input 69 dB CD, TUNER, LINE, TAPE-PLAY (TONE) 110 dB CD, TUNER, LINE, TAPE-PLAY (SOURCE) 114 dB
Power Supply:	European & U.K. & Australian models AC 230 V, 50 Hz U.S.A. & Canadian models AC 120 V, 60 Hz Worldwide models AC 120 V and AC 220-230 V switchable, 60 / 50 Hz
Dimensions (W \times H \times D):	435 \times 164 \times 428 mm 17-1/8" \times 6-7/16" \times 16-7/8"
Weight:	14.9 kg, 32.8 lbs.

Specifications and features are subject to change without notice.

SERVICE SAFETY PRECAUTIONS

1. Replacing the fuses

 This symbol located near the fuse indicates that the fuse used is fast operating type. For continued protection against fire hazard, replace with same type fuse. For fuse rating refer to the marking adjacent to the symbol.

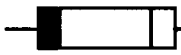
 Ce symbole indique que le fusible utilise est a rapide.

Pour une protection permanents, n'utiliser que des fusibles de meme type.

Ce dernier est indique la qu le present symbol est appose.

Circuit No.	Part No.	Description
F901	252153	6.3A-TSC, <D><W>
F902	252076	3.15A-SE-EAK <P><T> <W>
F903	252070	1A-SE-EAK <P><T>

2. Safety-check out

(Only U.S.A. model)

After correcting the original service problem, perform the following safety check before releasing the set to the customer.

Connect the insulating-resistance tester between the plug of power supply cord and the screw on the back panel.

Specifications : 3.3Mohm \pm 10% at 500V.

3. Voltage Selector (Rear Panel)

Worldwide models are equipped with a voltage selector to conform to local power supplied.

Be sure to set this switch to match the voltage of the power supply in your area before plugging in the unit. Models without a voltage selector can only be used in area where the power supply is the same as that of the unit.

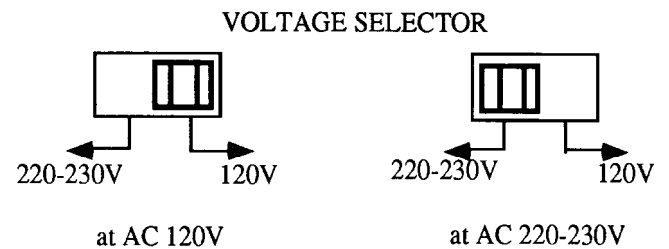

Setting the voltage selector

1. Determine the proper for voltage for your area : 220-230V or 120V.
2. If the preset voltage is not proper for your area, insert a screwdriver into the groove in the switch. Slide the switch all the way to the right (120V) or to the left (220-230V), which-ever is proper.

BLOCK DIAGRAM

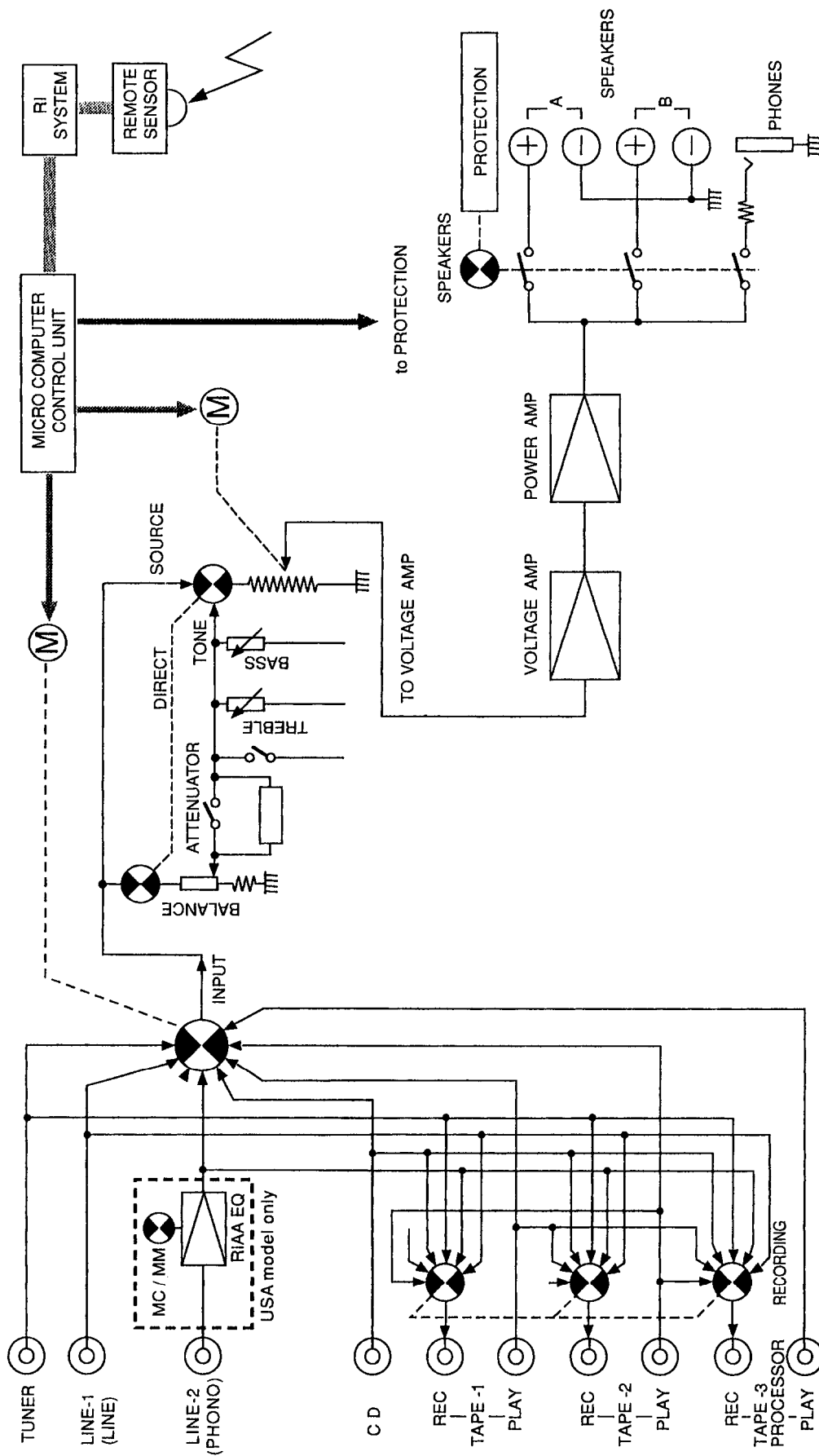

ADJUSTMENT PROCEDURES

Adjustments and Checking the Protection Circuitry

1. Preparations

- 1) Place the unit on the workbench. (There should be about 15 mm of space between the base plate of the unit and the work surface.)
- 2) Set up the unit as follows.
 - (1) No load
 - (2) No signal
 - (3) Volume turned all the way down
 - (4) Speaker switch OFF
 - (5) Power switch OFF

Note) Check the following points before making adjustments

- (1) The power switch should be OFF.
- (2) The interior of the unit should not be warm.

2. Idling current adjustment

- 1) Turn the power switch ON and allow the unit to warm up for about 10 minutes.
 - (1) Adjust R617(R618) so that the voltage at test point VCT-ID on the NAAF-5629 circuit board is $6.5\text{mV} \pm 2\text{mV}$.
- NOTE) Semi-fixed resistors enclosed in parentheses () are for the right channel.

3. Check of operation of protection circuitry

- 1) Check of operation of protection relay.
 - (1) Confirm that the relay turns ON approximately 5 seconds after the power switch is turned ON.
 - (2) The relay should turn OFF approximately 0.5 seconds after the power switch is turned OFF.
- 2) Check of DC detection
 - (1) Turn the power on with no load.
 - (2) After the speaker relay turns ON, apply DC +1~1.5V to the CD input terminals. Confirm that the relay turns OFF.
 - (3) Confirm that operation is the same as (2) above when an input of DC -1~-1.5V is applied.

Note) Under no circumstances connect a load or short the speaker terminals when performing the above test.
- 3) Confirmation of current detection operation
 - (1) Signal input from the circuit illustrated below with no load.
 - (2) Confirm that the speaker relay does not turn OFF even when a 2 ohm load is connected when a peak value of 35Vp-p is output.
 - (3) Next, confirm that when a 1 ohm load is connected the speaker relay switches OFF and ON a couple of times and then stays OFF.

Note) The period before that relay stays OFF should not last for more than 10 second. Relay OFF status can be canceled by switching the power OFF.

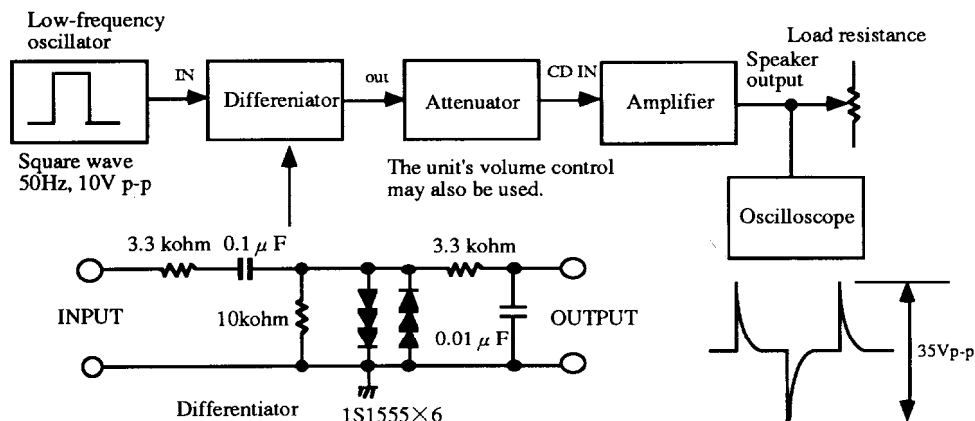

MICROPROCESSOR CONNECTION DIAGRAM

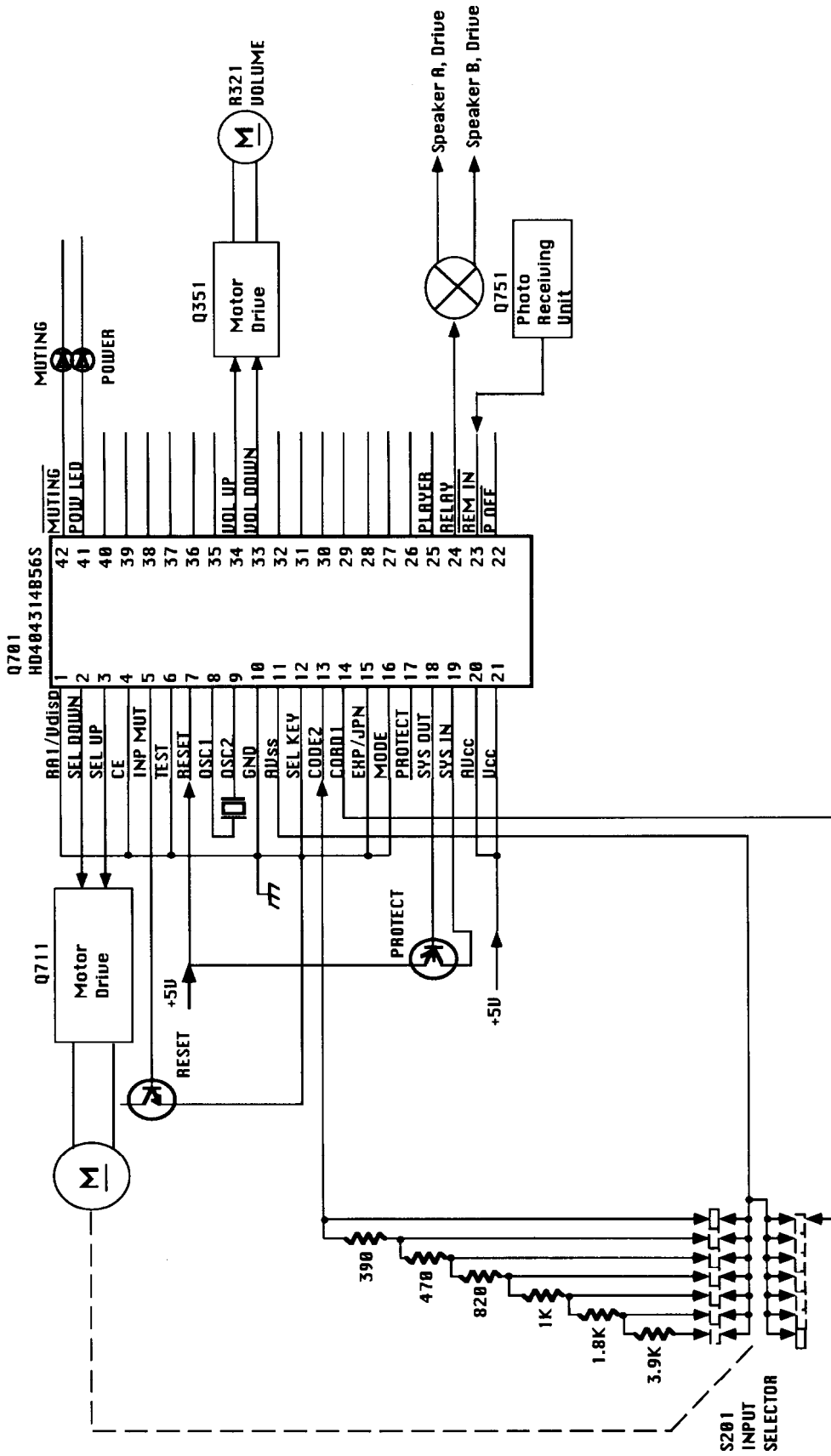

TERMINAL DESCRIPTION

Q701:HD404314B56S

Pin No.	CODE	FUNCTION	I/O	DESCRIPTION															
1	PA1/Vdisp		---	Not used. To be connected with GND.															
2	ROO/SCK	SEL DOWN	OUT	UP/DOWN Output terminal for Input selector. <table border="1" style="margin-left: 20px;"> <thead> <tr> <th>OPERATION</th> <th>SEL UP</th> <th>SEL DOWN</th> </tr> </thead> <tbody> <tr> <td>STOP</td> <td>H</td> <td>H</td> </tr> <tr> <td>UP</td> <td>H</td> <td>L</td> </tr> <tr> <td>DOWN</td> <td>L</td> <td>H</td> </tr> </tbody> </table>	OPERATION	SEL UP	SEL DOWN	STOP	H	H	UP	H	L	DOWN	L	H			
OPERATION	SEL UP	SEL DOWN																	
STOP	H	H																	
UP	H	L																	
DOWN	L	H																	
3	R01/SI	SEL UP																	
4	R02/SO	CE	---																
5	R03/TOC	INP MUT	OUT	Muting output terminal. Active "H".															
6	TEST	TEST	---	Shipment Test. To be connected with GND.															
7	RESET	RESET	IN	Input terminal for Reset signal. Active "L".															
8	OSC1	Xtal	---	Terminal for connecting with Ceramic oscillator (4.0MHz)															
9	OSC2	Xtal	---																
10	GND	GND	---	Ground terminal.															
11	AVss	AVss	---	Ground terminal of A/D converter.															
12	R30/AN0	SEL KBY	IN	Input terminal for when changing over Input Selector. Through A/D conversion, the selector will be detector on its right or left rotation.															
13	R31/AN1	CODE 2	IN	Code input terminal for detecting position of input switch of Motor driver.															
14	R32/AN2	CODE 1	IN	Cord input terminal for detecting position of input switch of Motor driver.															
15	R33/AN3	EXP/JPN	IN	Input terminal for change-over between Japan model and Export model.															
16	R40/AN4	MODE	IN	Input terminal for initialization to change over operation mode.															
17	R41/AN5	PROTECT	IN	Input terminal for detecting protect operation.															
18	R42/AN6	SYS OUT	OUT	Output terminal for System Code.															
19	R43/AN7	SYS IN	IN	Input terminal for System Code.															
20	AVcc	AVcc		Analog reference voltage for A/D conversion.															
21	Vss	Vss	---	Power (+5V) terminal.															
22	D0/INTO	P OFF	IN	Input terminal for Detecting Power suspension. However, "L" 100 μ S or under shall be ignored.															
23	D1/INT1	REM IN	IN	Remote control signal input terminal.															
24	D2/EVENB	RELAY	OUT	Output terminal for controlling relay. "H" when ON.															
25	D3/BUZZ	PLAYER		Not used.															
26	D4/STOPC		---	Not used.															
27	D5																		
28	D6																		
29	D7																		
30	D8																		
31	R80																		
32	R81																		
33	R82	VOL DOWN	OUT	UP/DOWN output terminal for Volume. Active "H". <table border="1" style="margin-left: 20px;"> <thead> <tr> <th>OPERATION</th> <th>VOL UP</th> <th>VOL DOWN</th> </tr> </thead> <tbody> <tr> <td>STOP</td> <td>H</td> <td>H</td> </tr> <tr> <td>VOL UP</td> <td>H</td> <td>L</td> </tr> <tr> <td>VOL DOWN</td> <td>L</td> <td>H</td> </tr> <tr> <td>POWER OFF</td> <td>L</td> <td>L</td> </tr> </tbody> </table>	OPERATION	VOL UP	VOL DOWN	STOP	H	H	VOL UP	H	L	VOL DOWN	L	H	POWER OFF	L	L
OPERATION	VOL UP	VOL DOWN																	
STOP	H	H																	
VOL UP	H	L																	
VOL DOWN	L	H																	
POWER OFF	L	L																	
34	R83	VOL UP																	
35	R10			Not used.															
36	R11																		
37	R12																		
38	R13																		
39	R20																		
40	R21		---																
41	R22	POW LED	---	Output terminal for Power LED.															
42	R23	MUTING	OUT	Output terminal for Audio muting LED, Remote control.															

CHASSIS EXPLODED VIEW PARTS LIST

REF.NO.	PART NO.	DESCRIPTION	REF.NO.	PART NO.	DESCRIPTION
2	27160361	Heat sink	Q617	2202514 or	* 2SA1695-Y or
4	801433	Self-tapping screw 3SMS8W.SW+14B(BC)		2202516	* 2SA1695-P Power transistor
8	838430167	Self-tapping screw 3TTB+16S(BC)	Q618	2202514 or	* 2SA1695-Y or
12	27130756B	Bracket (FH)		2202516	* 2SA1695-P Power transistor
14	800529	Bushing	Q619	2202524 or	* 2SC4468-Y or
15	838130088	Self-tapping screw 3TTB+8B		2202526	* 2SC4468-P Power transistor
16	27190966	Holder (PC)	Q620	2202524 or	* 2SC4468-Y or
18	27130757	Bracket (RH)		2202526	* 2SC4468-P Power transistor
23	27110889-2	Front bracket	F901	252153	△ 6.3A-TSC, Fuse <D><W>
24	27141649	Retainer (HP)	F902	252076	△ 3.15A-SE-EAK, Fuse <P><T><W>
26	838430107	Self-tapping screw 3TTB+10S(BC)	F903	252070	△ 1A-SE-EAK, Fuse <P><T>
27	27267871-1	Guide (SEL)	P005	25060151	Terminal (GND)
29	27267897B	Guide (D)	P901	253192HIT	△ AS-UC-6#18, AC Cord <D>
40	27130758B	Bracket (SHLD)		253193HIT	△ AS-CEE, AC Cord <P><T>
46	27130759A	Bracket (PT)		253198HIT	△ AS-BS, AC Cord <PB>
47	27270307	Spacer (PT) t=2		253233KAW	△ AS-CEE-2, AC Cord <W>
48	830440109	Self-tapping screw 4TTC+10C(BC)	S251a	25030384B	NRSF-106-30BU, Rotary Switch (Recording)
49	27190964-1	Holder (PT)	T901	2301157	△ NPT-1256D, Power Trans. <D>
53	27130760A	Bracket (R)		2301158	△ NPT-1256P, Power Trans. <P><T>
54	27190266	Holder, KGLS-12RF		2301159	△ NPT-1256DG, Power Trans <W>
55	27190965	Holder, KGPS-12RF		25055018	△ CV-K-1, CV PLUG
56	27300833	Clamp, WS-2NS	U1	1A632528-2A	NAAF-5628-2A, Main circuit pc board ass'y <D>
57	27141648	Retainer (INP)		1A632528-2B	NAAF-5628-2B, Main circuit pc board ass'y <P><T>
63	27190971B	Holder (CH)		1A632528-2C	NAAF-5628-2C, Main circuit pc board ass'y <W>
67	27260336	Shaft (SEL)AS	U2	1A632529-2A	NAAF-5629-2A, Power amp. pc board ass'y <D>
68	27273156A	Joint (SEL)		1A632529-2B	NAAF-5629-2B, Power amp. pc board ass'y <P><T>
73	27170306	Bottom Board		1A632529-2C	NAAF-5629-2C, Power amp. pc board ass'y <W>
74	801525	Self-tapping screw 3TTB+8B(BC)	U3	1A632530-2A	NAETC-5630-2A, Driver L pc board ass'y <D>
78	27175308A	Leg ass'y		1A632530-2B	NAETC-5630-2B, Driver L pc board ass'y <P><T>
79	837440169	Self-tapping screw 4TTT+16C(BC)		1A632530-2C	NAETC-5630-2C, Driver L pc board ass'y <W>
82	27300750	△ Cord Bushing #2271	U4	1A632530-2A	NAETC-5630-2A, Driver R pc board ass'y <D>
83	28141288	Cushion t=0.5x10x15		1A632530-2B	NAETC-5630-2B, Driver R pc board ass'y <P><T>
84	28325274	Knob (PUSH) <D>		1A632530-2C	NAETC-5630-2C, Driver R pc board ass'y <W>
	28325184A	Knob (PUSH) <G>	U5	1A632531-2A	NAETC-5631-2A, Speaker terminal pc board ass'y <D>
201	28184631A	Top Cover 		1A632531-2B	NAETC-5631-2B, Speaker terminal pc board ass'y <P><T>
	28184638A	Top Cover <S>		1A632531-2C	NAETC-5631-2C, Speaker terminal pc board ass'y <W>
	28184630A	Top Cover <G>	U6	1A632533-2A	NADG-5633-2A, Micro computer pc board ass'y <D>
202	28140695	Cushion		1A632533-2B	NADG-5633-2B, Micro computer pc board ass'y <P><T>
203	838440089	Self-tapping screw 4TTB+8C(BC) 		1A632533-2C	NADG-5633-2C, Micro computer pc board ass'y <W>
	838240089	Self-tapping screw 4TTB+8C(NI) <S><G>	U7	1A632534-2A	NAAF-5634-2A, Volume pc board ass'y <D>
204	28170044A	Bushing (COV)		1A632534-2B	NAAF-5634-2B, Volume pc board ass'y <P><T>
208	1A633121UP	Front Panel ass'y <S> <P>		1A632534-2C	NAAF-5634-2C, Volume pc board ass'y <W>
	1A632121UDN	Front Panel ass'y <D>	U8	1A632535-2A	NAAF-5635-2A, Equalizer amp pc board ass'y <D>
	1A632121UP	Front Panel ass'y <P><W><T>		1A632535-2B	NAAF-5635-2B, Equalizer amp pc board ass'y <P><T>
	1A634121	Front Panel ass'y <G> <W>		1A632535-2C	NAAF-5635-2C, Equalizer amp pc board ass'y <W>
230	28325264	Knob (POW)AS 	U9	1A632536-2A	NASW-5636-2A, Recording pc board ass'y <D>
	28325265	Knob (POW)AS <S>		1A632536-2B	NASW-5636-2B, Recording pc board ass'y <P><T>
	28325238	Knob (POW)AS <G>		1A632536-2C	NASW-5636-2C, Recording pc board ass'y <W>
231	27273160	Joint (POW)	U10	1A632537-2A	NASW-5637-2A, Mode/attenuator pc board ass'y <D>
234	28325268	Knob (VOL)AS 		1A632537-2B	NASW-5637-2B, Mode/attenuator pc board ass'y <P><T>
	28325269	Knob (VOL)AS <S>		1A632537-2C	NASW-5637-2C, Mode/attenuator pc board ass'y <W>
	28325240	Knob (VOL)AS <G>	U11	1A632538-2A	NADIS-5638-2A, Volume indicator pc board ass'y <D>
236	28325270	Knob (SEL)AS 		1A632538-2B	NADIS-5638-2B, Volume indicator pc board ass'y <P><T>
	28325271	Knob (SEL)AS <S>		1A632538-2C	NADIS-5638-2C, Volume indicator pc board ass'y <W>
	28325241	Knob (SEL)AS <G>	U12	1A632543-2A	NADIS-5643-2A, Connection pc board ass'y <D>
238	28325274	Knob (PUSH) 		1A632543-2B	NADIS-5643-2B, Connection pc board ass'y <P><T>
	28325275	Knob (PUSH) <S>		1A632543-2C	NADIS-5643-2C, Connection pc board ass'y <W>
	28325184A	Knob (PUSH) <G>	U13	1A632544-2A	NADIS-5644-2A, Input indicator pc board ass'y <D>
240	28325278	Knob (TONE)AS 		1A632544-2B	NADIS-5644-2B, Input indicator pc board ass'y <P><T>
	28325279	Knob (TONE)AS <S>		1A632544-2C	NADIS-5644-2C, Input indicator pc board ass'y <W>
	28325185B	Knob (TONE)AS <G>	U14	1A632539-2A	NAPS-5639-2A, Power supply pc board ass'y <D>
243	28325193	Knob (D)		1A632539-2B	NAPS-5639-2B, Power supply pc board ass'y <P><T>
244	28141314	Cushion (D)		1A632539-2C	NAPS-5639-2C, Power supply pc board ass'y <W>
402	27122167A	Rear Panel <D>	U15	1A632540-2A	NASW-5640-2A, Power switch pc board ass'y <D>
	27122170A	Rear Panel <G> <W>		1A632540-2B	NASW-5640-2B, Power switch pc board ass'y <P><T>
	27122168A	Rear Panel <S> <P><T>		1A632540-2C	NASW-5640-2C, Power switch pc board ass'y <W>
Q613	2202514 or	* 2SA1695-Y or	U16	1A632541-2A	NAETC-5641-2A, AC outlet pc board ass'y <D>
	2202516	* 2SA1695-P Power transistor		1A632541-2B	NAETC-5641-2B, AC outlet pc board ass'y <P><T>
Q614	2202514 or	* 2SA1695-Y or		1A632541-2C	NAETC-5641-2C, AC outlet pc board ass'y <W>
	2202516	* 2SA1695-P Power transistor	U17	1A632542-2A	NAAF-5642-2A, Direct pc board ass'y <D>
Q615	2202524 or	* 2SC4468-Y or		1A632542-2B	NAAF-5642-2B, Direct pc board ass'y <P><T>
	2202526	* 2SC4468-P Power transistor		1A632542-2C	NAAF-5642-2C, Direct pc board ass'y <W>
Q616	2202524 or	* 2SC4468-Y or			
	2202526	* 2SC4468-P Power transistor			

NOTE: <S> Silver Color version
 Black Color version
 <G> Gold Color version
 <D> U.S.A. and Canada model
 <C> Canada model
 <P> 230V model
 <W> Worldwide model
 <T> Taiwanese model

PRINTED CIRCUIT BOARD PARTS LIST

U-1 Main circuit pc board (NAAF-5628-2)

CIRCUIT NO. PART NO. DESCRIPTION

CIRCUIT NO.	PART NO.	DESCRIPTION
	IC	
Q571,Q572	222570	NJM4560D-X
	Transistors	
Q501,Q502	2212805 or 2212806 or 2212807	2SK389-GR or 2SK389-BL or 2SK389-V
Q503-Q508	2211732 or 2211733	2SC1845-F or 2SC1845-E
Q509,Q510	2211255	2SC1815-GR
Q511-Q516	2211455	2SA1015-GR
Q517,Q518	2213334	2SK373-Y
Q519-Q524	2211792 or 2211793	2SA992-F or 2SA992-E
Q525,Q526	2211732 or 2211733	2SC1845-F or 2SC1845-E
Q527-Q530	2211634	2SC2229-Y
Q531-Q534	2211354	2SA949-Y
Q971,Q972	2211945	2SK246-GR
Q973	2211255	2SC1815-GR
Q974	2211455	2SA1015-GR
Q975	2215173	2SB647A-C
Q976	2215163	2SD667A-C
	Diodes	
D971,D972	224472204	MTZJ22D, Zener
	Capacitors	
C501,C502	374721515	ECQ-B50V, 151K, Plastic <D>
C503, C504	374721515	ECQ-B50V, 151K, Plastic <D>
C507,C508	393044707	CE04W16V, 47M, Elect.
C553,C554	374721024	ECQ-B50V, 102J, Plastic <D>
C577-C580	393081007	CE04W50V, 10M, Elect.
C581-C584	393354717	CE04W25V, 470M, Elect.
C591-C594	393374717	CE04W63V, 470M, Elect.
C971,C972	393374717	CE04W63V, 470M, Elect.
C973,C974	393364707	CE04W35V, 47M, Elect.
	Resistors	
R527,R528	443522234	RS1/2WBJ, 22K, Metal oxide film
R529-R534	443528214	RS1/2WBJ, 820, Metal oxide film
R535,R536	443522714	RS1/2WBJ, 270, Metal oxide film
R537-R540	443525604	RS1/2WBJ, 56, Metal oxide film
R541,R542	443528214	RS1/2WBJ, 820, Metal oxide film
R543,R544	443528224	RS1/2WBJ, 8.2K, Metal oxide film
R545,R546	443522714	RS1/2WBJ, 270, Metal oxide film
R547-R550	443525604	RS1/2WBJ, 56, Metal oxide film
R591-R594	453630564	RNU1WCJ, 5.6, Metal
R971,R972	443525614	RS1/2WBJ, 560, Metal oxide film
R973,R974	443526814	RS1/2WBJ, 680, Metal oxide film
	Plugs	
P231a	25055135	NPLG-5P119
P321a	25055138	NPLG-8P122
P503a	25055715	NPLG-3P671
P504a	25055100	NPLG-3P84
P505	25055879	NPLG-10P835
	Sockets	
P505a	25051566	NSCT-10P1353
P591a,P591b	25051110	NSCT-6P897
	Terminal	
P506	25060061	1P-5
	Socket AS	
P191	2009990373	NSAS-6P0510 <D>

U-2 Power amp. circuit pc board (NAAF-5629-2)

CIRCUIT NO. PART NO. DESCRIPTION

CIRCUIT NO.	PART NO.	DESCRIPTION
	Transistors	
Q603-Q606	2212654	2SC3421-Y
Q607,Q608	2212644	2SA1358-Y
Q621,Q622	2211792 or 2211793	2SA992-F or 2SA992-E
Q851,Q852	2211732 or 2211733	2SC1845-F or 2SC1845-E
	Diodes	
D851-D853	223163 or 223205 or 223222	1SS133 or 1SS270A or WG713A
D855	224470512	MTZJ5.1B, Zener
	Coils	
L601-L604	5597-45502	
	Capacitors	
C601,C602	393042217	CE04W16V, 220M, Elect.
C603,C604	374791044	ECQ-V63V, 104J, Plastic
C605,C606	393054707	CE04W25V, 47M, Elect.
C607,C608	374791044	ECQ-V63V, 104J, Plastic
C621,C622	374732234	ECQ-V100V, 223J, Plastic
C637,C638	374734734	ECQ-V100V, 473J, Plastic
C651-C654	393391007	CE04W100V, 10M, Elect.
C681-C684	374721024	ECQ-B50V, 102J, Plastic <P><T>
C851	393322217	CE04W6.3V, 220M, Elect.
C855	393380477	CE04W50V, 4.7M, Elect.
C857,C858	374721044	ECQ-V50V, 104J, Plastic
	Resistors	
R617,R618	5210255	N06HR, 200BC, Trim
R621-R624	443521504	RS1/2WBJ, 15, Metal oxide film
R625-R628	443521014	RS1/2WBJ, 100, Metal oxide film
R633-R636	443523304	RS1/2WBJ, 33, Metal oxide film
R637-R640	443521004	RS1/2WBJ, 10, Metal oxide film
R641-R644	453532294	RNU1/WCJ, 0.22, Metal
R651-R658	4000145	MPC78-2WK-0.1, Metal plate
R683,R684	452830474	RNU3WCJ, 4.7, Metal
R691,R692	443623914	RS1WBJ, 390, Metal oxide film
	Plugs	
P621,P622	25055038	NPLG-2P29
P631,P632	25055872	NPLG-8P828
JL871b	25055630	NPLG-9P592
	Socket	
P631a	25051559	NSCT-8P1346
	Socket ass'y	
P503	2009990387	NSAS-6P0524
P504	2009990388	NSAS-6P0525
P753,P754	2009990370	NSAS-6P0507
	Relays	
RL851,RL852	25065275	NRL-2P5A-DC12-038
RL853	25065469	NRL-2P1A-DC12-078
	27160357	Heat Sink, (S3)
	838430107	3TTB+10S(BC), Self-tapping screw

U-3,4 Driver L/R pc board (NAETC-5630-2)

CIRCUIT NO. PART NO. DESCRIPTION

Transistors		
Q601	2212864	2SC3419-Y
Q609	2202684 or 2202683	* 2SA1859-Y or * 2SA1859-O
Q611	2202694 or 2202693	* 2SC4883-Y or * 2SC4883-O

U-5 Speaker terminal pc. board (NAETC-5631-2)

CIRCUIT NO. PART NO. DESCRIPTION

Terminal		
P651	25060134	NTM8PDMN063

U-6 Micro Computer pc board (NAAF-5633-2)

CIRCUIT NO. PART NO. DESCRIPTION

ICs		
Q351	22240239	TA7291S
Q701	22240996	HD404314B56S
Q704	222951	MS1943BS
Q711	22240358	LB1638
Transistors		
Q702	2213510T	DTA114ES
Q703	2213290T	DTC114ES
Diodes		
D351	22380046T or 22380035T	AM01Z or GP104003E
D703	223163T or 223205T or 223222T	1SS133 or 1SS270A or WG713A
D704	224470562T	MTZJ5.6B, Zener
D705	223163T or 223205T	1SS133 or 1SS270A
D872	225324D or 225324C	SEL6910A-D, LED or SEL6910A-C, LED
Remote Sensor		
Q751	241302 or 24130012	PIC-12043, TH2, Remote sensor or TFMS5380B, Remote sensor
Coils		
L701-L704	230905	BL02RN1-R62
Capacitors		
C702	375524744T	MMT-50V, 474J, Plastic
C708	353744709T	CE04W16V, 47M, Elect.
C716	374724744S	ECQ-V50V, 474J, Plastic
C801	374724734T	ECQ-V50V, 473J, Plastic
C873	374724734T	ECQ-V50V, 473J, Plastic
Plug		
P802a	25055183	NPLG-2P167
Resonator		
X701	3010150T	CST4.00MGW, Ceramic lock
	27300833	WS-2NS, Clamp
	27190470	KGLS-18S, Holder

U-7 Volume pc board (NAAF-5634-2)

CIRCUIT NO. PART NO. DESCRIPTION

Coils		
L707,L708	230905	BL02RN1-R62

CIRCUIT NO. PART NO.

Resistor		
R321	5104329	N16RGM50KBT25F, Variable (Volume)

S321	25040076	Switch NLS-162-915-L049, Lever (Direct)
------	----------	--

P321	2009990377	Socket AS NSAS-16P0514
------	------------	---------------------------

JL321b	25055632	Plug NPLG-11P594, Wire trap
--------	----------	--------------------------------

U-8 Equalizer pc board (NAAF-5635-2)

CIRCUIT NO. PART NO. DESCRIPTION

Transistors		
Q101-Q104	2212185T or 2212186T	* 2SK170-GR or * 2SK170-BL <D>
Q109	22240191	NJM4565D-D <D>
Q191	222780153	78L15 <D>
Q192	222790153	79L15 <D>
L705,L706	230905	BL02RN1-R62

Capacitors		
C101-C104	374721015T	ECQ-B50V, 101K, Plastic <D>
C105,C106	374722224T	ECQ-B50V, 222J, Plastic <D>
C107,C108	393354717T	CE04W25V, 470M, Elect. <D>
C109,C110	391654717S	CE04W25V, 470M, Elect. <D>
C111,C112	374724724T	ECQ-B50V, 472J, Plastic <D>
C113,C114	374721015T	ECQ-B50V, 101K, Plastic <D>
C115,C116	374721524T	ECQ-B50V, 152J, Plastic <D>
C117,C118	391680227T	CE04W50V, 2.2M, Elect. <D>
C119,C120	374722224T	ECQ-B50V, 222J, Plastic <D>
C191,C192	393351027S	CE04W25V, 1000M, Elect. <D>
C195,C196	393344717T	CE04W16V, 470M, Elect. <D>
C201-C208	374721015T	ECQ-B50V, 101K, Plastic <P><T>

R191,R192	443523304T	Resistors RS1/2WBJ, 33, Metal oxide film <D>
-----------	------------	---

S101	25035672	Switches NPS-142-L625, Push (Cart. Sel) <D>
S201	25030389	NRSM-337-20BA, Rotary (Input)

P101	25045398	Jacks NPJ-2PDWH223 (Phono) <D>
P202	25045469	NPJ-4PDBL287 (Line, Tuner)
P203	25045398	NPJ-2PDWH223 (Line-2) <P><T><W>
P211	25045311	NPJ-2PDBL168
P851	25045330	NPJ-2PDBL184

P231	2009990409	Socket AS NSAS-10P0551
------	------------	---------------------------

P191a	25055234	Plug NPLG-3P218 <D>
-------	----------	------------------------

U-9 Recording pc board (NASW-5636-2)

CIRCUIT NO. PART NO. DESCRIPTION

Capacitors		
C251,C252	374721015T	ECQ-B50V, 101K, Plastic <P><T>
C255,C256	374721015T	ECQ-B50V, 101K, Plastic <P><T>
C259,C260	374721015T	ECQ-B50V, 101K, Plastic <P><T>

S251	25065398	Switch NSS-66150, Slide (Recording)
------	----------	--

CIRCUIT NO.	PART NO.	DESCRIPTION
Jacks		
P251-P253	25045469	NPJ-4PDBL287 (Tape-1,2,3)
U-10 Mode/Attenuator pc board (NCSW-5637-2)		
CIRCUIT NO.	PART NO.	DESCRIPTION
Switches		
S401,S402	25035591	NPS-222-L553, Push (Mode, Attenuator)
Socket		
P401a	25051232	NSCT-7P1022
U-11 Volume Indicator pc board (NADIS-5638-2)		
CIRCUIT NO.	PART NO.	DESCRIPTION
Diode		
D801	225324D or 225324C	SEL6910A-D, LED or SEL6910A-C, LED
Socket AS		
P801	2009990408	NSAS-4P0545
U-12 Connection pc board (NADIS-5643-2)		
CIRCUIT NO.	PART NO.	DESCRIPTION
Capacitor		
C802	374724734T	ECQ-V50V, 473J, Plastic
U-13 Input Indicator pc board (NADIS-5644-2)		
CIRCUIT NO.	PART NO.	DESCRIPTION
Diode		
D802	225324D or 225324C	SEL6910A-D, LED or SEL6910A-C, LED
Socket AS		
P802	2009990384	NSAS-4P0521
U-14 Power Supply pc board (NAPS-5639-2)		
CIRCUIT NO.	PART NO.	DESCRIPTION
ICs		
Q901,Q902	222780055	78M05HF
Diodes		
D921	22380270F	△ D5FB60
D922,D923	223208F	6A2
D931-D934	22380046T or 22380035T	△ AM01Z or GP104003E
Coil		
L901	231069A	NCH-1119, CHOKE COIL
Capacitors		
C921,C922	3500193	CE62W63V, 12000M, Elect.
C923,C924	374503345S	ME93M125V, 334K, Plastic
C926	374501055S	ME93M125V, 105K, Plastic
C931,C932	374722235T	ECQ-B50V, 223K, Plastic
C933	393343327S	CE04W16V, 3300M, Elect.
C934-C937	374722234T	ECQ-B50V, 223J, Plastic
Resistors		
R921	443525604T	RS1/2WBJ, 56, Metal oxide film
R941	453530104T	RNU1/2WCJ, 1, Metal
R942	443521024T	RS1/2WBJ, 1K, Metal oxide film

NOTE: THE COMPONENTS IDENTIFIED BY MARK △ ARE CRITICAL FOR RISK OF FIRE AND ELECTRIC SHOCK. REPLACE ONLY WITH PART NUMBER SPECIFIED.

CIRCUIT NO.	PART NO.	DESCRIPTION
Plugs		
P921	25055167	NPLG-4P151
P931	25055165	NPLG-2P149
Heat sink, RAD-51		
838430107 Self-tapping screw 3TTB+10S(BC)		
27301856 RG-416231, Bus bar		
U-15 Power Switch pc board (NASW-5640-2)		
CIRCUIT NO.	PART NO.	DESCRIPTION
Capacitors		
C901	3500191	△ DE7150F103M, IS
C903	3500163	△ WY2472M, CMCFOK, IS
C904	3500163	△ WY2472M, CMCFOK, IS <P><T><W>
Switch		
S901	25035550	△ NPS-121-L512P, Push (Power)
Plugs		
P901	25055675	△ NPLG-2P631 <D><P><T><W>
P902	25055166	NPLG-3P150 <D>
	25055168	NPLG-5P152 <P><T><W>
Fuse holders		
F901a	25050065	YSH403T, Fus holder <D><W>
F902a	25050065	YSH403T, Fush holder <P><T><W>
F903a	25050065	YSH403T, Fuse holder<P><T>
P905	25065425	Terminal,GND
U-16 AC Outlet pc board (NAETC-5641-2)		
CIRCUIT NO.	PART NO.	DESCRIPTION
Switch		
S904	25065437	△ NSS-22157P, Slide <T>
Socket AS		
P922	2009990371A	NSAS-12P0508
Sockets		
P903	25051571	△ NSCT-2P1358, AC Outlet <D>
P903	25051572	△ NSCT-2P1359, AC Outlet <P><T><W>
U-17 Direct pc board (NAAF-5642-2)		
CIRCUIT NO.	PART NO.	DESCRIPTION
Transistor		
Q871	2211164T	2SC2120-Y
Capacitors		
C331,C332	374721524T	ECQ-B50V, 152J, Plastic
C333,C334	374721534T	ECQ-B50V, 153J, Plastic
C335,C336	374721544T	ECQ-V50V, 154J, Plastic
C337,C338	374722234T	ECQ-B50V, 223J, Plastic
Resistors		
R331	5142018	N16RGM C250K MN30F, Variable (Balance)
R332	5142019	N16RGM C100K30F, Variable (Treble)
R333	5144019	N16RQM C70K 88K30F, Variable (Bass)
Switch		
S871	25030380	NRSF-125-30YW-S, Rotary (SP, Sel)
Plugs		
JL781b	25055627	NPLG-6P589, Wire trap
P401	25055703	NPLG-7P659
P871	25045337	HLJ4317-01-3120, Jack (H.P.)

NOTE: <S> Silver Color version <C> Canada model
 Black Color version <P> 230V model
 <G> Gold Color version <W> Worldwide model
 <D> U.S.A. and Canada model <T> Taiwanene model

PACKING PARTS LIST

REF. NO.	PART NO.	DESCRIPTION
601	29052957	Carton Box
	29052958	Carton Box <S>
	29052959	Carton Box <G>
603	29091425E	Pad (L)
604	29091426F	Pad (R)
607	261504	Paper Tape W=30
613	29100035A	Poly Bag
614	282301	Staple
615	29110071	PP Tape
617	29360404	SN Sheet
Accessory bag ass'y		
	29100097-1AY	Poly Bag
	29365019BY	Warranty Card <D>
	29355133A	Insert Sheet (DBP) <S> <P>
	29358002KY	SS List <D>
	29361931	UPC Label <D>
	3010054	Battery UM-3
	24140312	Remote Control ass'y, RC-312S <D>
	24140314	Remote Control ass'y, RC-314S <P><T><W>
	29342259A	Instruction Manual, E <P><D><T><W>
	29342260	Instruction Manual, U6 <P><C>
	29342262	Instruction Manual, T <W><T>

NOTE: <S> Silver Color version
 Black Color version
 <G> Gold Color version
 <D> U.S.A. and Canada model
 <C> Canada model
 <P> 230V model
 <W> Worldwide model
 <T> Taiwanene model

ONKYO CORPORATION

International Sales Div. : 31 Sankyo-bld. 3-8-5, Asakusabashi, Taito-ku, TOKYO 111, JAPAN
 TEL : 03-5820-5865 FAX : 03-5820-5869

ONKYO U.S.A. CORPORATION
 200 Williams Drive, Ramsey, N.J. 07446, U.S.A.
 TEL : 201-825-7950 FAX : 201-825-8150

ONKYO EUROPE ELECTRONICS GmbH
 Industriestrasse 18-20, 82110 Germering, GERMANY
 TEL : 089 84 93 20 FAX : 089 84 93 226

ONKYO FRANCE
 Immeuble Le Diamant, Domaine Technologique de Saclay, 4 Rue Rene Razel, 91892 SACLAY, FRANCE
 TEL : (1) 69 33 14 00 FAX : (1) 69 41 35 84