

ONKYO SERVICE MANUAL

AUDIO VIDEO CONTROL AMPLIFIER

MODEL A-SV610PRO



Black model

BHMD, BHMDN, BHMDX	120V AC, 60Hz
BHMP, BHMPV	230V AC, 50Hz
BHMW, BHMWX	120/220V AC, 50/60Hz
BHMQA	240V AC, 50Hz

SAFETY-RELATED COMPONENT WARNING!!

COMPONENTS IDENTIFIED BY MARK Δ ON THE SCHEMATIC DIAGRAM AND IN THE PARTS LIST ARE CRITICAL FOR RISK OF FIRE AND ELECTRIC SHOCK. REPLACE THESE COMPONENTS WITH ONKYO PARTS WHOSE PARTS NUMBERS APPEAR AS SHOWN IN THIS MANUAL.

MAKE LEAKAGE CURRENT OR RESISTANCE MEASUREMENTS TO DETERMINE THAT EXPOSED PARTS ARE ACCEPTABLY INSULATED FROM THE SUPPLY CIRCUIT BEFORE RETURNING THE APPLIANCE TO THE CUSTOMER.

TABLE OF CONTENTS

Specifications.....	2
Precautions.....	2
Adjustment procedures.....	3
Exploded view.....	4
Parts list.....	5
Microprocessor descriptions.....	6
IC block diagrams and descriptions.....	9
Block diagram.....	18
Schematic diagram.....	27
Connection diagram of microprocessor.....	27
Power supply and video section.....	29
Audio section.....	31
Surround section.....	33
Printed circuit board-parts list.....	35
System connections.....	39
Packing view.....	40

ONKYO

AUDIO COMPONENTS

SPECIFICATIONS

AMPLIFIER SECTION

Power Output:	Stereo mode Front L/R channels 125 watts per channel min. RMS. at 8 ohms, both channels driven, from 20 Hz to 20,000 Hz, with no more than 0.08% total harmonic distortion. Dynamic power: 2 × 240 watts at 4 ohms 2 × 160 watts at 8 ohms
	Surround mode and Multi source mode Front L/R and center channels 70 watts per channel min. RMS. at 8 ohms, 1,000 Hz, with no more than 0.08% total harmonic distortion. Rear or Remote channels 20 watts per channel min. RMS. at 8 ohms, 1,000 Hz, with no more than 0.8% total harmonic distortion.
Total Harmonic Distortion:	0.08% at rated power (FRONT)
IM Distortion:	0.08% at rated power (FRONT)
Damping Factor:	60 at 8 ohms (FRONT)
Sensitivity and Impedance:	Phono: 2.5 mV/50 kohms CD/Tape Play: 150 mV/50 kohms Tape Rec: 150 mV/2.2 kohms

Phono Overload:	120 mV RMS. at 1,000 Hz, 0.5% THD.
Frequency Response:	20 to 30,000 Hz, +/-1 dB
RIAA Deviation:	20 to 20,000 Hz, +/-0.8 dB
Tone Control:	BASS: +/-10 dB at 100 Hz TREBLE: +/-10 dB at 10,000 Hz
Signal to Noise Ratio:	PHONO: 80 dB (IHF A, 5 mV input) CD/TAPE: 100 dB (IHF A)
Muting:	-∞ dB

VIDEO SECTION

Signal sensitivity and impedance
VIDEO input, output: 1 Vp-p, 75 ohms

GENERAL

Dimensions (W × H × D):	455 × 170 × 388 mm 17-15/16" × 6-11/16" × 15-1/4"
Weight:	13.5 kg (29.8 lbs)

Specifications and external appearance are subject to change without notice because of product improvements.

PRECAUTIONS

1. Replacing the fuses

For continued protection against risk of fire hazard, replace only with same type and same rating fuse.

Circuit No.	Part No.	Description
F901	252166Y	6.3A-UL/T-237, Primary fuse <D/W>
F902	252076	3.15A-SE-EAK, Primary fuse <P/W/Q>
F903	252075	2.5A-SE-EAK, AC outlet fuse <P>
F911,F912	252166Y	6.3A-UL/T-237, Secondary fuse <D>
F911,F912	252079	6.3A-SE-EAK, Secondary fuse <P/W/Q>

NOTE: <D>:120V model only
<P>:230V model only
<W>:Worldwide model only
<Q>:240V model only

2. Perform a reset

This device employs a microprocessor to perform various functions and operations. If interference generated by an external power supply, radio waves, or other electrical source results in an accident which causes the specified operations and functions to operate abnormally. To perform a reset, please follow the procedure below.

1. Press and hold down the CD button, then press the POWER button.
2. "Test-" is displayed on the display for approximately 5 seconds.
3. While "Test-" is displayed, unplug the unit's power supply cord from its AC outlet, then "Test-" will disappear.
4. Preset memory and parameters stores in memory, such as surround are initialized and will return to the factory settings.

3. Safety-check out

(Only U.S.A. model)

After correcting the original service problem perform the following safety check before releasing the set to the customer.

Connect the insulating-resistance tester between the plug of power supply cord and terminal GND on the back panel.

Specifications: More than 10MΩ at 500V.

ADJUSTMENT PROCEDURES

1. Idle Current Adjustment

1) Preparation

There should be no load and no signal, the volume knob should be at the minimum position, and the speaker and power switches should be off.

2) Turn the power switch to on.

Adjust the trim resistors R511, R512 and R546 so that the voltage at the test points for the left, center and right channels (P521, P522 and P551) is 1.2mV to 2.2mV.

4) Five minutes later, readjust to 5 ± 0.5 mV.

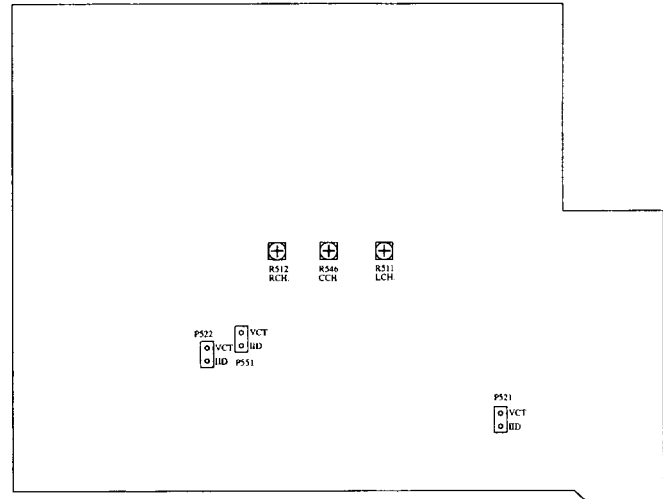

2. Checking the Operation of the Protection Circuit

● Preparation

Press and hold down the CD button, then press the POWER button.

"Test-" is displayed on the FL tube for approximately 5 seconds.

While "Test-" is displayed, press the VIDEO-1 button.

"Test-1-01" is displayed and the unit becomes the test mode.

● Checking DC voltage detection

1) When there is no load on the amplifier, confirm that the protection circuit is triggered when a DC voltage of 1.5V to 3V is applied to the test point P621.

2) Confirm that the protection circuit is also triggered when a voltage of -1.5V to -3V is applied.

● Checking current detection

Apply the signal as shown below to CD terminal.

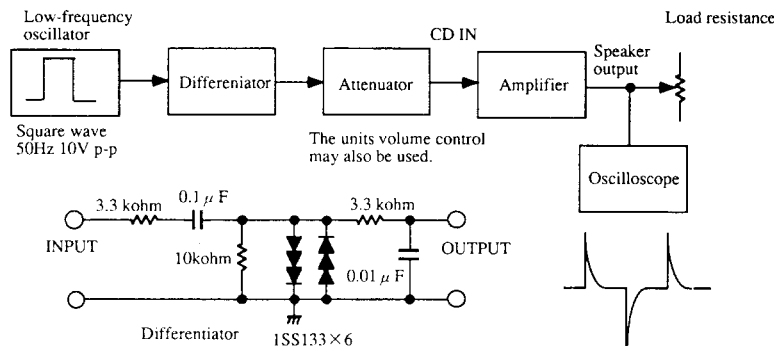

1. Left, right and center channel confirmation

Adjust the volume knob so that the output voltage is 35V peak for the above three channels when there is no load on the amplifier.

Connect a 2-ohm load and confirm that protection circuit is not triggered.

Connect a 1.5-ohm load and confirm that protection circuit is triggered.

2. Rear channel confirmation

Adjust the volume knob so that the output voltage is 15V peak for the above two channels when there is no load on the amplifier.

Connect a 2-ohm load and confirm that protection circuit is not triggered.

Connect a 1.5-ohm load and confirm that protection circuit is triggered.

CHASSIS EXPLODED VIEW PART LIST

REF.NO.	PART NO.	DESCRIPTION	REF.NO.	PART NO.	DESCRIPTION	REF.NO.	PART NO.	DESCRIPTION
1	27121728Y	Rear panel <D>	U4	1A434595-3	AS-CEE, Power supply cord <P>	U4	1A434595-3	NAETC-4695-3,Headphone terminal pc board ass'y
	27121729Y	Rear panel <P>	253175Y	253175Y	AS-SAA,Power supply cord <Q>	U6	1A434519-1	NADIS-4719-1,Display circuit pc board ass'y
	27121730AY	Rear panel <V>	253170	253170	AS-CEE-2, Power supply cord <W>	U7	1A434520-1	NAAF-4720-1,Surround circuit pc board ass'y
	27121731Y	Rear panel <W>	253172 or	253092-1A	NSCT-2P697,AC outlet <Q>	U8	1A434521-1	NAETC-4721-1,RI/MR terminal pc board ass'y
	27121732Y	Rear panel <Q>	P902,P903	25050904	25C4029-R or			
2	838440109	4TTB+10C(BC),Self-tapping screw	Q505,Q506	2202662 or	25C4029-O,Power transistors			
3	27130717AY	Bracket,power transformer	Q507,Q508	2202672 or	2SA1553-R or			
4	27115255Y	Side bracket		2202673	2SA1553-O,Power transistors			
5	27141607AY	Retainer H	Q543	2201653,	2SC3856-O, 2SC3856-Y, 2SC3907-R or	U9	1A434522-1	NASW-4722-1,STC switch pc board ass'y
6	27130718AY	Bracket H		2201654,	2SC3907-O,Power transistor	U11	1A434502-3	NAPS-4702-3,Power supply circuit pc board ass'y <D>
7	27160324Y	Radiator		2202272 or	2SA1492-Y, 2SA1516-R or			
8	27141530A	Retainer HS-2	Q544	2201664,	2SA1492-P, 2SA1516-O,Power transistor			
9	27141532	Retainer PD-1		2202273	2SA1492-Y, 2SA1516-R or			
10	27300750	Cord,bushing		2202262 or	2SA1516-O,Power transistor			
11	27190369	KGLS-22S,Holder		2202263	2SC4511-Y or			
12	27190480	KGLS-8S,Holder	Q575,Q576	2202063, or	2SC4511-P,Power transistors	U12	1A434503-3	NAAF-4703-3,Rear amplifier pc board ass'y <D>
13	27190062	KGLS-12S,Holder		2202066	2SA1725-O, 2SA1725-Y or			
14	801433	3SMS8W,SW+14B(BC),Sems screw	Q577,Q578	2202053,	2SA1725-P,Power transistors	U13	1A434504-3	NAAF-4704-3,Tone control circuit pc board ass'y <P>
15	834430088	3TTS+8B(BC),Self-tapping screw		2202054 or	NPT-1170D,Power transformer <D>			
16	833430080	3TTP+8P(BC),Self-tapping screw	T901	2300897A	NPT-1170P,Power transformer <P>	U14	1A434505-3	NAETC-4705-3,Video circuit pc board ass'y
17	830440089	4TTC+8C(BC),Self-tapping screw		2300898	NPT-1170DG,Power transformer <W>	U15	1A434506-3	NAETC-4706-3,Video input terminal pc board ass'y <D>
18	831130088	3TTW+8B,Self-tapping screw		2300899	NPT-1170Q,Power transformer <Q>			
19	834430108	3TTS+10B(BC),Self-tapping screw	U1	1A434592-3	NAAR-4692-3,Main circuit pc board ass'y <D>			
20	27110765BY	Front bracket ass'y		1A434592-3A	NAAR-4692-3A,Main circuit pc board ass'y <P/W/Q>	U16	1A434507-3	NAETC-4707-3,Tuner input terminal pc board ass'y <D>
21	28184540Y	Top cover		1A434592-3B	NAAR-4692-3B,Main circuit pc board ass'y <C>			
22	838440109	4TTB+10C(BC),Self-tapping screw	U2	1A434593-3	NAETC-4693-3,Center speaker terminal pc board ass'y <D>			
23	28141272Y	10t X 60 X 20,Cushion		1A434593-3A	NAETC-4693-3A,Center speaker terminal pc board ass'y <P/W/Q>			
24	28140546	0.5 t X 390 X 10,Cushion	U3	1A434594-3	NAETC-4694-3,Speaker terminal pc board ass'y <D>			
25	27170300AY	Bottom panel		1A434594-3A	NAETC-4694-3A,Speaker terminal pc board ass'y <P/W/Q>			
26	27190926	KGLS-18RF,Holder						
27	27175251AY	Leg	U1	1A434592-3	NAAR-4692-3,Main circuit pc board ass'y <D>			
28	1A434701K	Front panel ass'y		1A434592-3A	NAAR-4692-3A,Main circuit pc board ass'y <P/W/Q>			
29	28125251Y	End cap L	U2	1A434592-3B	NAAR-4692-3B,Main circuit pc board ass'y <C>			
30	28125252Y	End cap R						
31	28191653A	Clear plate						
32	28133293Y	Back plate						
33	28324775	Knob VOLUME						
34	28324376A	Knob TONE						
35	260220	WS-3NS,Clamp						
F901	252166Y	6.3A-UL/T-237,Primary fuse <D/W>						
F902	252076	3.15A-SE-EAK,Primary fuse <P/W/Q>						
F903	252075	2.5A-SE-EAK,Primary fuse <P>						
F911,F912	252166Y	6.3A-UL/T-237,Secondary fuse <D>						
	252079	6.3A-SE-EAK,Secondary fuse <P/W/Q>						
JL701	2041322010 or	NCFE1-322010 or						
	2047322012Y	NCFE7-322012,Flexible flat cable						
P306	25060044	Terminal,ground						
P901	253163Y or	AS-UC-6 #18,						
	253174Y	Power supply cord <D/PX>						

NOTE: <D>:120V model only
<P>:230V model only
<V>:Germany model only
<W>:Worldwide model only
<Q>:240V model only
<PX>:PX model only
<C>:Canadian model only

NOTE: THE COMPONENTS IDENTIFIED BY MARK  ARE CRITICAL FOR RISK OF FIRE AND ELECTRIC SHOCK. REPLACE ONLY WITH PART NUMBER SPECIFIED.

CAUTION:
Replacement for transistor of mark *, if necessary must be made from the same beta group (HFE) as the original type.

MICROPROCESSOR DESCRIPTIONS

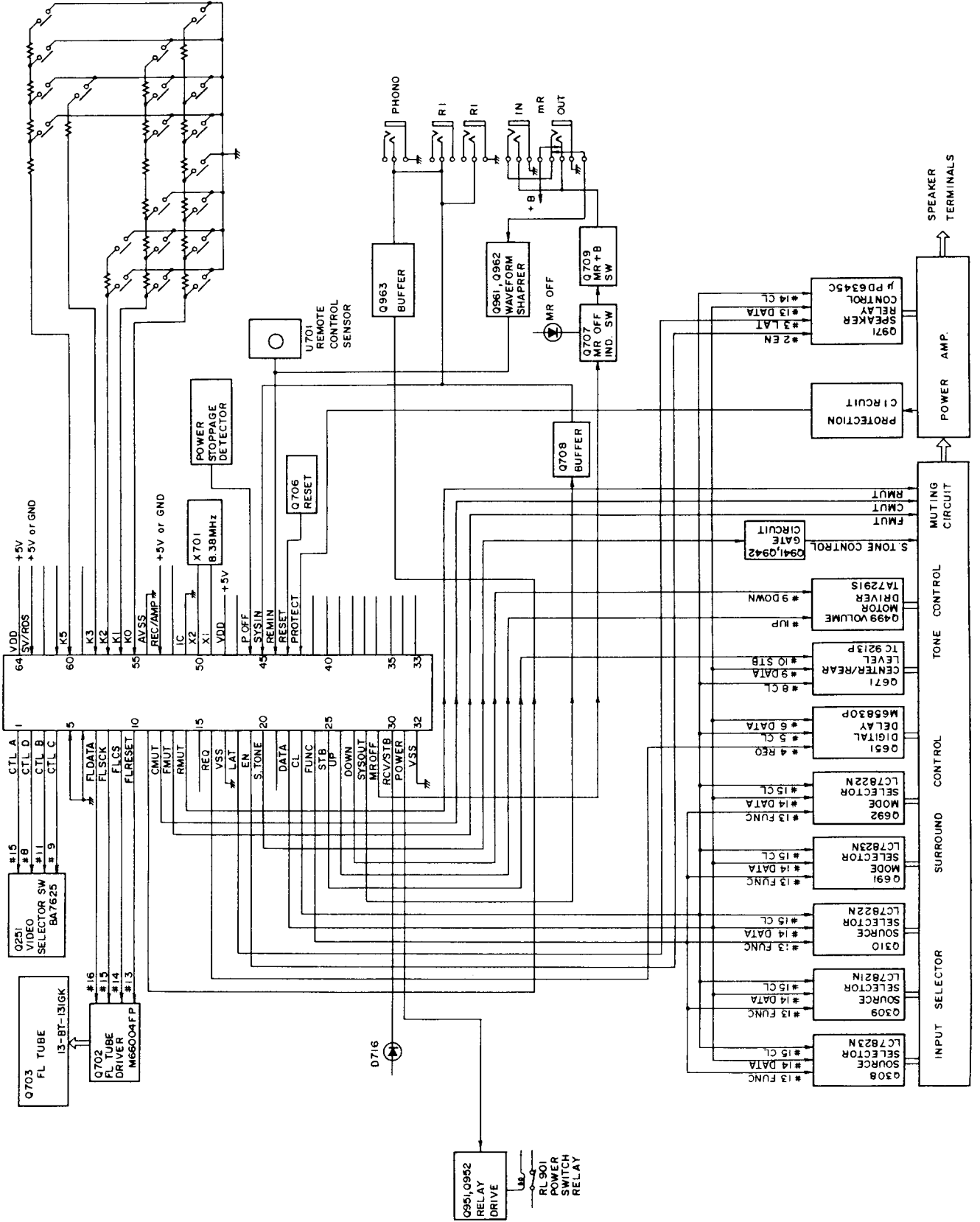

Terminal Description

Pin No.	Function	I/O	Description												
1	VCTLA	O	Video signal control A output terminal.												
2	VCTLD	O	Video signal control D output terminal.												
3	VCTLB	O	Video signal control B output terminal.												
4	VCTLC	O	Video signal control C output terminal.												
5	BAND0	I	Initializing input terminal for FM/AM band region.												
6	BAND1	I	Not used.												
7	FLDATA	O	Connect to the terminal SDATA of Fluorescent tube driver M66004FP (Q702).												
8	FLSCK	O	Connect to the terminal SCK of Fluorescent tube driver M66004FP.												
9	FLCS	O	Connect to the terminal CS of Fluorescent tube driver M66004FP.												
10	FLRESET	O	Connect to the terminal RESET of Fluorescent tube driver M66004FP.												
11	PLAYER	O	Turntable control output terminal.												
12	CMUT	O	Muting output terminal for the center amplifier.												
13	FMUT	O	Muting output terminal for the front amplifier.												
14	RMUT	O	Muting output terminal for the rear amplifier.												
15	TUMUT	O	Muting output terminal for the tuner section. Not used.												
16	REQ	O	Connect to the terminal REQ of Digital delay M65830P (Q651).												
17	VSS	-	Ground terminal												
18	LAT	O	Connect to the terminal LAT of Output extended IC μ PD6345C (Q971).												
19	EN	O	Connect to the terminal EN of Output extended IC μ PD6345C.												
20	S.TONE	O	Selective tone control output terminal.												
21	PLL	O	Connect to the terminal CE of PLL IC. Not used.												
22	DATA	O	Connect to the terminal DI of Analog switches LC7821N, LC7822N, and LC7823N, the terminal DATA of Electro volume TC9213P, the terminal DATA of Digital delay M65830P, and the terminal SIN of Output extended IC μ PD6345C.												
23	CL	O	Connect to the terminal CL of Analog switches LC7821N, LC7822N, and LC7823N, the terminal CK of Electro volume TC9213P, the terminal SCK of Digital delay M65830P, and the terminal SCK of Output extended IC μ PD6345C.												
24	FUNC	O	Connect to the terminal CE of Analog switches LC7821N, LC7822N, and LC7823N (Q309, Q310, Q692, Q308 and Q691).												
25	STB	O	Connect to the terminal STB of Electro volume TC9213P (Q671).												
26	VOLUP	O	Volume UP/DOWN control output terminal. <table border="1" style="margin-left: auto; margin-right: auto;"> <thead> <tr> <th>Operation</th> <th>#27</th> <th>#26</th> </tr> </thead> <tbody> <tr> <td>Stop</td> <td>H</td> <td>H</td> </tr> <tr> <td>Volume Up</td> <td>L</td> <td>H</td> </tr> <tr> <td>Volume Down</td> <td>H</td> <td>L</td> </tr> </tbody> </table>	Operation	#27	#26	Stop	H	H	Volume Up	L	H	Volume Down	H	L
Operation	#27	#26													
Stop	H	H													
Volume Up	L	H													
Volume Down	H	L													
27	VOLDOWN	O													
28	SYSOUT	O	System code output terminal.												

VIDEO SIGNAL CONTROL OUTPUT

Input Selector

#1	#3	SOURCE
L	L	VIDEO-3
H	L	VIDEO-2
L	H	
H	H	VIDEO-1

Recording Selector

#4	#2	SOURCE
L	L	VIDEO-3
H	L	VIDEO-2
L	H	
H	H	VIDEO-1
Same as #1	Same as #3	Other position
Same as #1	Same as #3	Multi mode

Pin No.	Function	I/O	Description
29	$\overline{\text{MR}}$	O	MULTI ROOM indicator control output.
30	$\overline{\text{STBY/RECV}}$	O	STAND-BY/RECEIVED indicator control output.
31	POWER	O	Power switch relay control output.
32	VSS	-	Ground terminal.
33	————	O	Not used.
34	————	O	Not used.
35	————	O	Not used.
36	————	O	Not used.
37	————	O	Not used.
38	————	O	Not used.
39	————	I	Not used.
40	————	I	Not used.
41	————	I	Not used.
42	PROTECT	I	Protection circuit operation detection input terminal.
43	$\overline{\text{RESET}}$	I	System reset input terminal.
44	$\overline{\text{REMIN}}$	I	Remote control signal input terminal.
45	$\overline{\text{SYSIN}}$	I	System code input terminal.
46	$\overline{\text{POFF}}$	I	Detection input terminal for the stoppage of electric current.
47	————	I	Not used.
48	VDD		Power supply terminal.(+5V)
49	X2		Ceramic resonator connection terminal for the main system clock .
50	X1		Connect the ceramic resonator 8.38 MHz.
51	IC		Connect to the ground terminal.
52	XT2		Not used.
53	XT1		
54	AVSS		Ground terminal of A/D converter.
55	K0	I	Operation key connection terminals.
56	K1	I	
57	K2	I	
58	K3	I	
59	K4	I	
60	K5	I	
61	————		Not used.
62	MODE	I	Initializing input terminal for Receiver or Amplifier.
63	AVDD		Analogue power supply terminal of A/D converter. (+5V)
64	AVREF		Reference voltage input terminal of A/D converter.

Q703
13-BT-131GK (Fluorescent Indicator Tube)

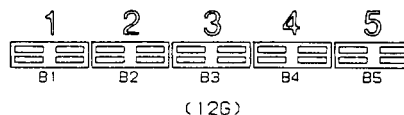
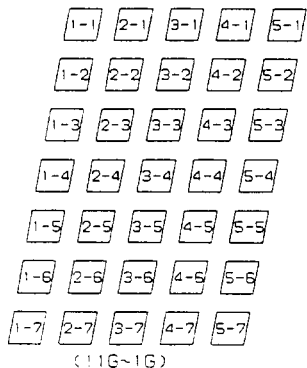
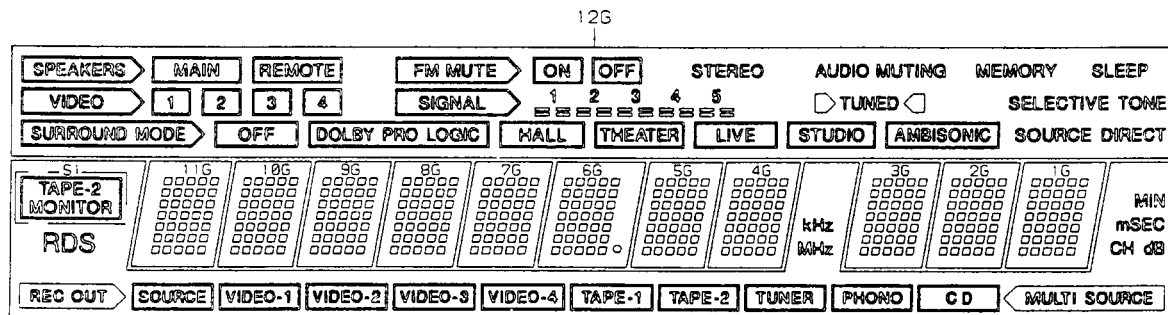

	13G	12G	11G~7G	6G	5G~1G
P1	MIN	SLEEP	1-1	1-1	1-1
P2	mSBC	MEMORY	2-1	2-1	2-1
P3	dB	AUDIO MUTING	3-1	3-1	3-1
P4	CH	SELECTIVE TONE	4-1	4-1	4-1
P5	MULTI SOURCE	SOURCE DIRECT	5-1	5-1	5-1
P6	REC OUT	TUNED	1-2	1-2	1-2
P7	SOURCE	TUNED	2-2	2-2	2-2
P8	SOURCE	STEREO	3-2	3-2	3-2
P9	VIDEO-1	OFF (Center)	4-2	4-2	4-2
P10	VIDEO-1	ON	5-2	5-2	5-2
P11	VIDEO-2	FM MUTE	1-3	1-3	1-3
P12	VIDEO-2	AMBISONIC	2-3	2-3	2-3
P13	VIDEO-3	STUDIO	3-3	3-3	3-3
P14	VIDEO-3	LIVE	4-3	4-3	4-3
P15	VIDEO-4	THEATER	5-3	5-3	5-3
P16	VIDEO-4	HALL	1-4	1-4	1-4
P17	TAPE-1	DOLBY PRO LOGIC	2-4	2-4	2-4
P18	TAPE-1	OFF (LEFT)	3-4	3-4	3-4
P19	TAPE-2	SURROUND MODE	4-4	4-4	4-4
P20	TAPE-2	1 2 3 4 5	5-4	5-4	5-4
P21	TUNER	B5	1-5	1-5	1-5
P22	TUNER	B4	2-5	2-5	2-5
P23	PHONO	B3	3-5	3-5	3-5
P24	PHONO	B2	4-5	4-5	4-5
P25	CD	B1	5-5	5-5	5-5
P26	CD	SIGNAL	1-6	1-6	1-6
P27	kHz	REMOTE	2-6	2-6	2-6
P28	MHz	MAIN	3-6	3-6	3-6
P29	SI	SPEAKERS	4-6	4-6	4-6
P30	RDS	4	5-6	5-6	5-6
P31		3	1-7	1-7	1-7
P32		2	2-7	2-7	2-7
P33		1	3-7	3-7	3-7
P34		VIDEO	4-7	4-7	4-7
P35			5-7	5-7	5-7
P36				○	

PIN NO.	64	63	62	61	60	59	58	57
CONNECTION	F2	F2	NP	NP	P36	P35	P34	P33
PIN NO.	56	55	54	53	52	51	50	49
CONNECTION	P32	P31	P30	P29	P28	P27	P26	P25
PIN NO.	48	47	46	45	44	43	42	41
CONNECTION	P24	P23	P22	P21	P20	P19	P18	P17
PIN NO.	40	39	38	37	36	35	34	33
CONNECTION	P16	P15	P14	P13	P12	P11	P10	P9
PIN NO.	32	31	30	29	28	27	26	25
CONNECTION	P8	P7	P6	P5	P4	P3	P2	P1
PIN NO.	24	23	22	21	20	19	18	17
CONNECTION	NC	NC	NC	NC	NC	NC	NC	13G
PIN NO.	16	15	14	13	12	11	10	9
CONNECTION	12G	11G	10G	9G	8G	7G	6G	5G
PIN NO.	8	7	6	5	4	3	2	1
CONNECTION	4G	3G	2G	1G	NP	NP	F1	F1

BLOCK DIAGRAM

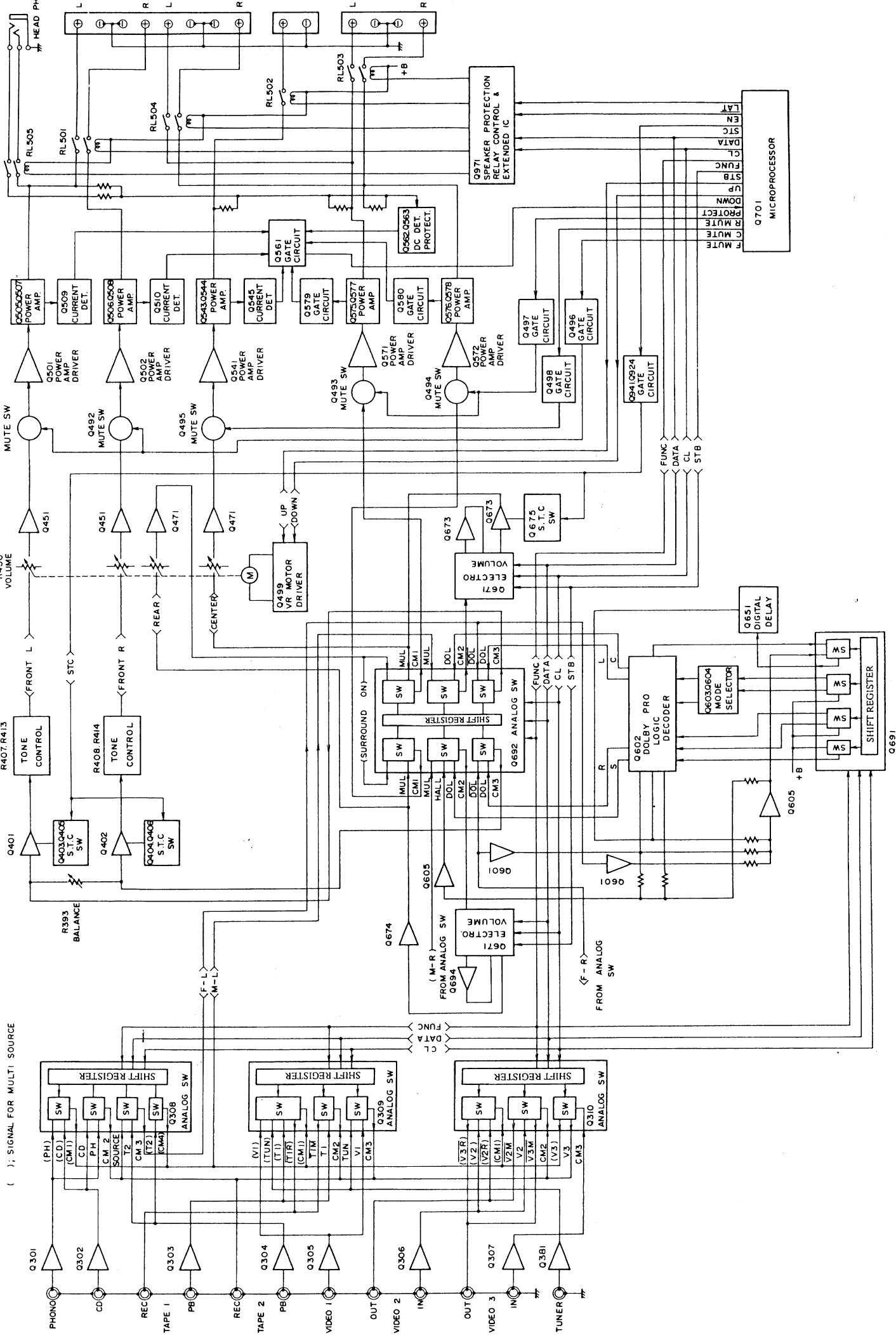

CHEMATIC DIAGRAM PART 1 CONNECTION DIAGRAM OF MICROPROCESSOR

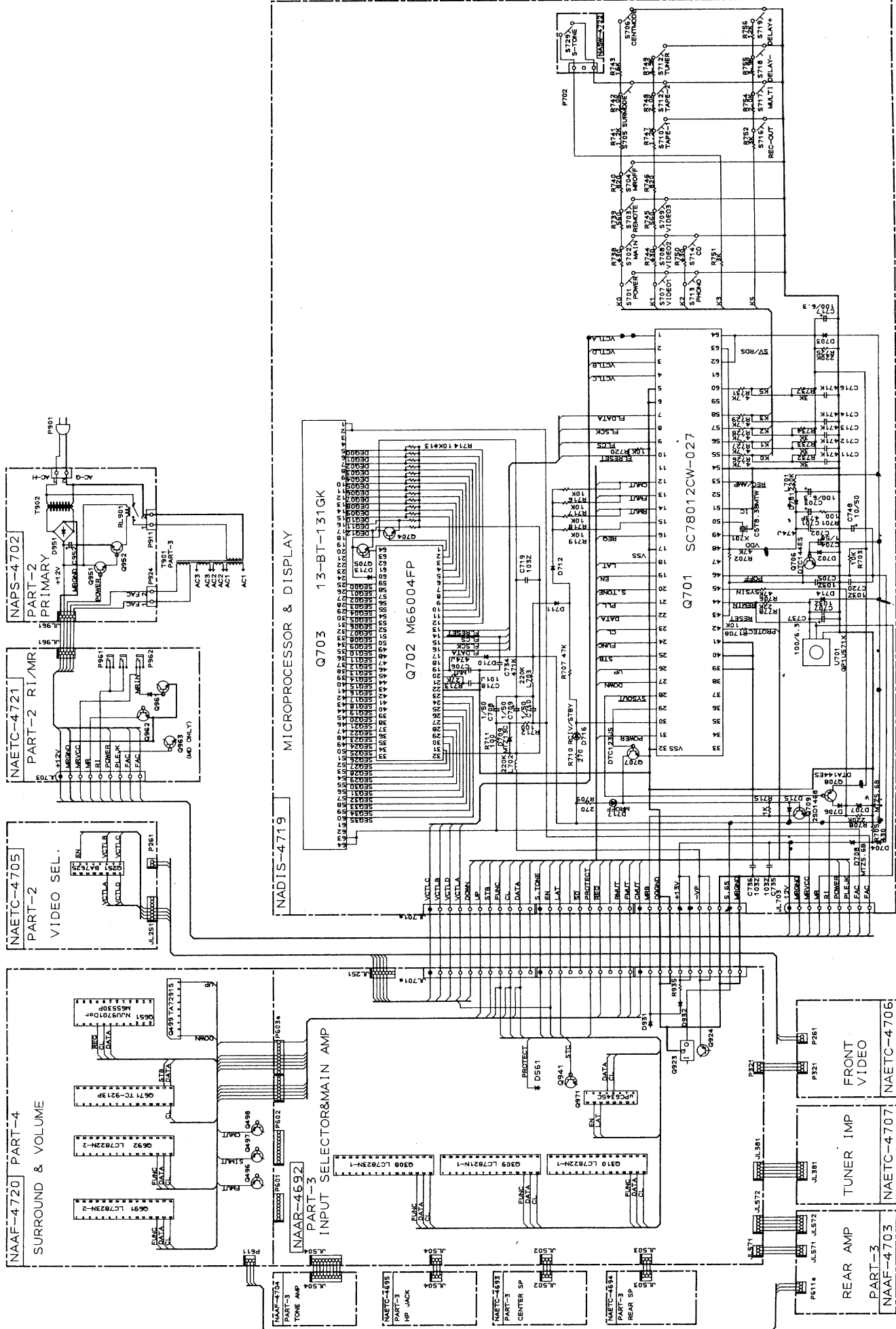

CHEMATIC DIAGRAM PART 3
AUDIO SECTION

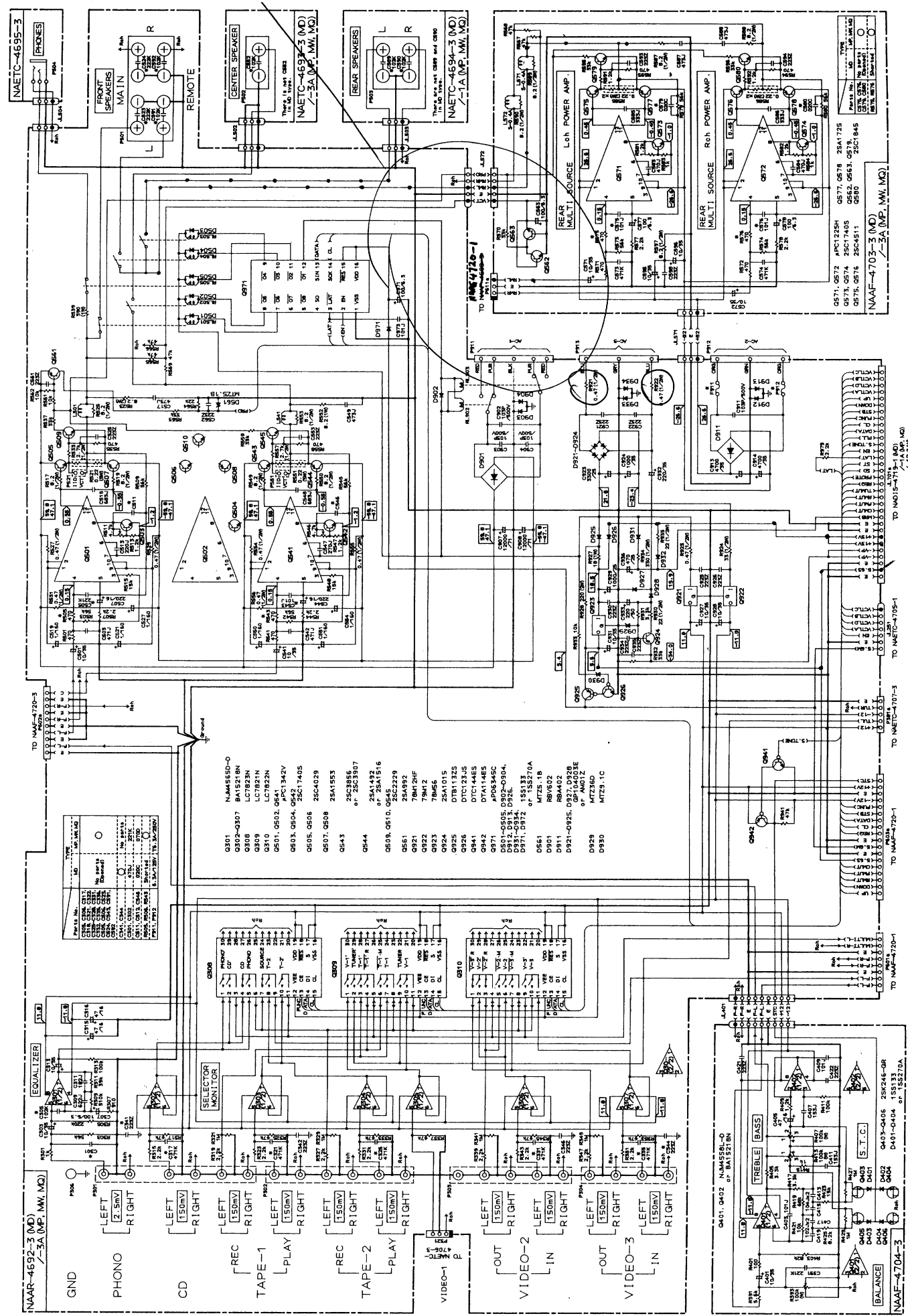

PRINTED CIRCUIT BOARD – PARTS LIST





CAUTION:

Replacement for transistor of mark *, if necessary must be made from the same beta group (HFE) as the original type.

MAIN CIRCUIT PC BOARD (NAAR-4692-3/3A/3B)

CIRCUIT NO.	PART NO.	DESCRIPTION	CIRCUIT NO.	PART NO.	DESCRIPTION
	ICs				
Q301	22240191	NJM4565D-D	D931-D934	223205 or	1SS270A or
Q302-Q307	22240247	BA15218N	D971	223163	1SS133
Q308	22240339	LC7823N		Coils	
Q309	22240280	LC7821N	L501,L502	231209S	S-0.4A
Q310	22240270	LC7822N	L541	231209S	S-0.4A
Q501,Q502	22240694Y	μ PC1342V		Capacitors	
Q541	22240694Y	μ PC1342V	C303,C304	354761009	10 μ F,35V,Elect.
Q921	222780125NEC	78M12HF	C307,C308	354721019	100 μ F,6.3V,Elect.
Q922	222790125	79M12	C309,C310	374726224	6200pF \pm 5%,50V,Plastic
Q923	222780565JRC	78M56	C311,C312	374721824	1800pF \pm 5%,50V,Plastic
Q971	22240211	μ PD6345C	C313,C314	354761009	10 μ F,35V,Elect.
	Transistors		C315,C316	354744709	47 μ F,16V,Elect.
Q503,Q504	2213284	2SC1740S-R	C501,C502	354761009	10 μ F,35V,Elect.
Q505,Q506	2202663 or	☆ 2SC4029-O or	C503,C504	374724714	470pF \pm 5%,50V,Plastic
	2202662	☆ 2SC4029-R	C507,C508	354742219	220 μ F,16V,Elect.
Q507,Q508	2202673 or	☆ 2SA1553-O or	C515,C516	374726834	0.068 μ F \pm 5%,50V,Plastic
	2202672	☆ 2SA1553-R	C517,C518	374724734	0.047 μ F \pm 5%,50V,Plastic
Q509,Q510	2211633 or	2SC2229-O or	C519-C522	354700109	1 μ F,160V,Elect.
Q545	2211634	2SC2229-Y	C527,C528	354700109	1 μ F,160V,Elect.
Q542	2213284	2SC1740S-R	C541	354761009	10 μ F,35V,Elect.
Q543	2201653,	☆ 2SC3856-O,	C542	374724714	470pF \pm 5%,50V,Plastic
	2201654,	☆ 2SC3856-Y,	C544	354742219	220 μ F,16V,Elect.
	2201655,	☆ 2SC3856-P,	C548	374726834	0.068 μ F \pm 5%,50V,Plastic
	2202272 or	☆ 2SC3907-R or	C549	374724734	0.047 μ F \pm 5%,50V,Plastic
	2202273	☆ 2SC3907-O	C550,C551	354700109	1 μ F,160V,Elect.
Q544	2201663,	☆ 2SA1492-O,	C554	354700109	1 μ F,160V,Elect.
	2201664,	☆ 2SA1492-Y,	C907,C908	3504259	12000 μ F,71V,Elect.
	2201665,	☆ 2SA1492-P,	C913,C914	3504213	4700 μ F,35V,Elect.
	2202262 or	☆ 2SA1516-R or	C923	354753329	3300 μ F,25V,Elect.
	2202263	☆ 2SA1516-O	C924	354761029	1000 μ F,35V,Elect.
Q561	2211792 or	2SA992-F or	C927,C928	354761009	10 μ F,35V,Elect.
	2211793	2SA992-E	C929	354751029	1000 μ F,25V,Elect.
Q924	2211455	2SA1015-GR	C931	354761009	10 μ F,35V,Elect.
Q925	2213830	DTB113ZS	C932	354762219	220 μ F,35V,Elect.
Q926	2213640	DTC123JS	C933	354782219	220 μ F,50V,Elect.
Q941	221282	DTC144ES	C936	354754719	470 μ F,25V,Elect.
Q942	2213510	DTA114ES	C971	354721019	100 μ F,6.3V,Elect.
	Diodes			Resistors	
D501-D505	223205 or	1SS270A or	R511,R512	5210261	N06HR 5KBC,Trim
D902-D904	223163	1SS133	R517-R520	452530824	8.2 ohm,1/2W,Metal
D561	224450512	MTZ5.1B	R521,R522	4000132	0.22 ohm, 5W,Metal plate
D901	22380038	RBV602	R523,R524	451730824	8.2 ohm, 2W,Metal
D911	22380048	RBA402	R525,R526	452530824	8.2 ohm,1/2W,Metal
D912,D913	223205 or	1SS270A or	R527-R532	452534794	0.47 ohm,1/2W,Metal
D926	223163	1SS133	R533,R534	442522724	2.7 kohm,1/2W,Metal oxide
D921-D925	22380046 or	AM01Z or	R539,R540	441623914	390 ohm,1W,Metal oxide
D927,D928	22380035	GP104003E	R546	5210261	N06HR 5KBC,Trim
D929	224453004	MTZ30D	R549,R550	452530824	8.2 ohm,1/2W,Metal
D930	224450913	MTZ9.1C	R551	4000132	0.22 ohm \times 2,5W+5W,Metal plate
			R552	451630824	8.2 ohm,1W,Metal

NOTE: THE COMPONENTS IDENTIFIED BY MARK  ARE CRITICAL FOR RISK OF FIRE AND ELECTRIC SHOCK. REPLACE ONLY WITH PART NUMBER SPECIFIED.

CIRCUIT NO.	PART NO.	DESCRIPTION
	Resistors	
R553	452530824	8.2 ohm,1/2W,Metal
R554-R556	452534794	0.47 ohm,1/2W,Metal
R557	442522724	2.7 kohm,1/2W,Metal oxide
R921-R923	452534794	0.47 ohm,1/2W,Metal
R924	442523304	33 ohm,1/2W,Metal oxide
R927	441621804	18 ohm,1W,Metal oxide
R928	441722214	220 ohm,2W,Metal oxide
R930,R935	442522204	22 ohm,1/2W,Metal oxide
R934	442523314	330 ohm,1/2W,Metal oxide
	Relaies	
RL501	25065339	NRL-2P5A-DC24-046
RL502	25065379	NRL-1P5A-DC24-058
RL503,RL504	25065339	NRL-2P5A-DC24-046
RL505	25065470	NRL-2P1.25A-DC24-079
RL902,RL903	25065435	 NRL-1P10A-DC24-072
	25065480	 NRL-1P10A-DC24-083, (Canadian model only)
	Fuses	
F911,F912	252166Y	 6.3A-UL/T-237 <D>
	252079	 6.3A-SE-EAK <P/W/Q>
	Fuseholders	
F911A,F912A	25050065	 YSH403T
	Plugs	
P322A	25055133Y	NPLG-3P117
P601A	25055498	NPLG-8P473
P602A	25055499	NPLG-10P474
P603A	25055503	NPLG-18P478
	Terminals	
P301,P302	25045300	NPJ-6PDBL-159
P303,P304	25045303	NPJ-4PDBL-162
P501	25060125	NTM-8PDMN058
	Wire traps	
JL381	25050527	NSCT-5P350
JL401	25050531	NSCT-9P354
JL701A	25050612 or 25050705Y	NSCT-32P423 or NSCT-32P509

CENTER SPEAKER TERMINAL PC BOARD (NAETC-4693-3/3A)

CIRCUIT NO.	PART NO.	DESCRIPTION
P502	25060114	NTM-2PDML-048,Speaker terminal

SPEAKER TERMINAL PC BOARD (NAETC-4694-3/3A)

CIRCUIT NO.	PART NO.	DESCRIPTION
P503	25060161	NTM-4PDML-087,Speaker terminal

HEADPHONE TERMINAL PC BOARD (NAETC-4695-3)

CIRCUIT NO.	PART NO.	DESCRIPTION
P504	25045257	YKB26-5138,Headphone terminal

DISPLAY CIRCUIT PC BOARD (NADIS-4719-1/1A/1B)

CIRCUIT NO.	PART NO.	DESCRIPTION
	Remote control sensor	
U701	24130007	GPU571X
	FL tube	
Q703	212120	13-BT-131GK
	ICs	
Q701	22240684	SC78012CW-027
Q702	22240685R9	M66004FP
	Transistors	
Q704,Q705	2213284	2SC1740S-R
Q706	221282	DTC144ES
Q707	2213640	DTC123JS
Q708	2213510	DTA114ES
Q709	2212794	2SD1468-R
	Diodes	
D701-D706	223205 or	1SS270A or
D710-D715	223163	1SS133
D707,D708	224450562	MTZ5.6B
D709	224451303	MTZ13C
D716,D717	225142	SEL2913K,LED
	Resonator	
X701	3010205	CST8.38MTW,Ceramic
	Coils	
L701-L703	233411K220	NCH-1387
	Capacitors	
C701	3000059	0.047F,5.5V,Super
C702	375524744	0.47 μ F \pm 5%,50V,Plastic
C703	354721019	100 μ F,6.3V,Elect.
C704	354780109	1 μ F,50V,Elect.
C708-C710	354780109	1 μ F,50V,Elect.
C717,C731	354721019	100 μ F,6.3V,Elect.
C732,C737	354721019	100 μ F,6.3V,Elect.
C748	354761009	10 μ F,35V,Elect.
	Resistor	
R714	49163103413	10 kohm \times 13,1/10W,Array
	Switches	
S701-S714	25035548	NPS-111-S510
S716-S719	25035548	NPS-111-S510
	Wire trap	
JL701B	25050578 or 25050726	NSCT-32P389 or NSCT-32P530
	Plug	
P702A	25055510Y	NPLG-3P485
	Holders	
D712A,D716A	27190843	
Q703A	27190913Y	

NOTE: THE COMPONENTS IDENTIFIED BY MARK  ARE CRITICAL FOR RISK OF FIRE AND ELECTRIC SHOCK. REPLACE ONLY WITH PART NUMBER SPECIFIED.

SURROUND CIRCUIT PC BOARD (NAAF-4720-1)

CIRCUIT NO.	PART NO.	DESCRIPTION
	ICs	
Q451,Q471	22240247 or 22240293	BA15218N or NJM4558L-D
Q499	22240239	TA7291S
Q601,Q605	22240247 or	BA15218N or
Q673,Q674	22240293	NJM4558L-D
Q602	22240683 or 22240692	NJM2177L or M69032P
Q651	22240686 or 22240687	M65830P or NJU9701D
Q671	22240266	TC9213P
Q691	22240339	LC7823N
Q692	22240270	LC7822N
	Transistors	
Q491-Q495	2213631 or	RN1241-A or
Q603,Q604	2213632	RN1241-B
Q496-Q498	2213510	DTA114ES
Q675	2213631 or 2213632	RN1241-A or RN1241-B
	Diodes	
D651,D652	223205 or 223163	1SS270A or 1SS133
	Coil	
L651	233411K220	NCH-1387
	Resonator	
X651	3010217	CST2.04MG040,Ceramic
	Capacitors	
C451,C452	354780229	2.2 μ F,50V,Elect.
C459-C462	354761009	10 μ F,35V,Elect.
C471,C472	354780229	2.2 μ F,50V,Elect.
C479-C482	354761009	10 μ F,35V,Elect.
C491-C493	354761009	10 μ F,35V,Elect.
C494	354721019	100 μ F,6.3V,Elect.
C601,C602	354761009	10 μ F,35V,Elect.
C605,C606	354761009	10 μ F,35V,Elect.
C607-C610	354781099	0.1 μ F,50V,Elect.
C613,C614	374724734	0.047 μ F \pm 5%,50V,Plastic
C615,C616	374722234	0.022 μ F \pm 5%,50V,Plastic
C617-C620	354781099	0.1 μ F,50V,Elect.
C621,C622	354780479	4.7 μ F,50V,Elect.
C623-C627	354782299	0.22 μ F,50V,Elect.
C628	354761009	10 μ F,35V,Elect.
C629	354786899	0.68 μ F,50V,Elect.
C630	374724734	0.047 μ F \pm 5%,50V,Plastic
C631,C660	374725624	5600pF \pm 5%,50V,Plastic
C632,C651	354780229	2.2 μ F,50V,Elect.
C634	354722219	220 μ F,6.3V,Elect.
C635	354741019	100 μ F,16V,Elect.
C636-C641	354761009	10 μ F,35V,Elect.
C642,C661	374724724	4700pF \pm 5%,50V,Plastic

CIRCUIT NO.	PART NO.	DESCRIPTION
	Capacitors	
C643	354761009	10 μ F,35V,Elect.
C644	392841007	10 μ F,16V,Elect.
C647-C649	354761009	10 μ F,35V,Elect.
C653	374723924	3900pF \pm 5%,50V,Plastic
C655,C659	374726834	0.068 μ F \pm 5%,50V,Plastic
C656	354744709	47 μ F,16V,Elect.
C657,C658	354781099	0.1 μ F,50V,Elect.
C663,C665	354721019	100 μ F,6.3V,Elect.
C666	375524744	0.47 μ F \pm 5%,50V,Plastic
C671,C672	354780229	2.2 μ F,50V,Elect.
C675,C676	354761009	10 μ F,35V,Elect.
C677,C678	354780229	2.2 μ F,50V,Elect.
C679,C680	354761009	10 μ F,35V,Elect.
C681,C682	354780109	1 μ F,50V,Elect.
C683,C684	374721034	0.01 μ F \pm 5%,50V,Plastic
C685,C686	354761009	10 μ F,35V,Elect.
	Resistor	
R450	5144017Y	N16RQL50KA25F,Variable,Volume
	Sockets	
P601	25050445	NSCT-8P269
P602	25050446	NSCT-10P270
P603	25050450	NSCT-18P274
P611	2000802ULY	NSAS-6P758
	Plug	
P621	25055411	NPLG-9P393

RI/MR TERMINAL PC BOARD (NAETC-4721-1/1A)

















CIRCUIT NO.	PART NO.	DESCRIPTION
	Transistors	
Q961,Q962	221282	DTC144ES
Q963	221282	DTC144ES <D>
	Diodes	
D961-D963	223205 or 223163	1SS270A or 1SS133
	Capacitors	
C961	354761009	10 μ F,35V,Elect.
C962	374724724	4700pF \pm 5%,50V,Plastic
	Jacks	
P961	25045293	HSJ-1003-01-012
P962	25045172	HSJ-1003-01-020
	Wire trap	
JL961	25050527	NSCT-5P350

STC SWITCH PC BOARD (NASW-4722-1)







CIRCUIT NO.	PART NO.	DESCRIPTION
S729	25035548	NPS-111-S510,Switch
P702B	25050454	NSCT-3P278,Socket

NOTE: THE COMPONENTS IDENTIFIED BY MARK  ARE CRITICAL FOR RISK OF FIRE AND ELECTRIC SHOCK. REPLACE ONLY WITH PART NUMBER SPECIFIED.

POWER SUPPLY CIRCUIT PC BOARD (NAPS-4702-3/3A/3B/3C/3D)

CIRCUIT NO.	PART NO.	DESCRIPTION
	Transistors	
Q951	221282	DTC144ES
Q952	2213650	DTD113ZS
	Diodes	
D951-D954	22380046 or 22380035	AM01Z or GP104003E
D955-D957	223205 or 223163	1SS270A or 1SS133
	Power transformer	
T902	2300670	 NPT-1111D <D>
	2300671	 NPT-1111P <P>
	2300672	 NPT-1111DG <W>
	2300673	 NPT-1111Q <Q>
	Relay	
RL901	25065248	 NRL-1P15A-DC12-29
	Capacitors	
C901	3500065A	 DE7150FZ103PAC400/125V,IS
C952	354742219	220 μ F,16V,Elect.
	Resistor	
R951	452530824	 8.2 ohm, 1/2W, Metal
	Fuse	
F901	252166Y	 6.3A-UL/T-237 <D/W>
F902	252076	 3.15A-SE-EAK <P/W/Q>
F903	252075	 2.5A-SE-EAK <P>
	Fuseholders	
F901A	25050065	 YSH403T <D/W>
F902A	25050065	 YSH403T <P/W/Q>
F903A	25050065	 YSH403T <P>
	AC outlet	
P902	25050388	 NSCT-6P215 <D>
	25050640	 NSCT-4P451 <P/W>
	Switch	
S901	25065437	 NSS-22157P <W>

REAR AMPLIFIER PC BOARD (NAAF-4703-3/3A)

CIRCUIT NO.	PART NO.	DESCRIPTION
	ICs	
Q571,Q572	22240108	μ PC1225H
	Transistors	
Q562,Q563	2211732 or	2SC1845-F or
Q579,Q580	2211733	2SC1845-E
Q573,Q574	2213284	2SC1740S-R
Q575,Q576	2202063,	 2SC4511-O,
	2202064 or	 2SC4511-Y or
	2202066	 2SC4511-P
Q577,Q578	2202053,	 2SA1725-O,
	2202054 or	 2SA1725-Y or
	2202056	 2SA1725-P
	Coils	
L571,L572	231209S	S-0.4A

CIRCUIT NO.	PART NO.	DESCRIPTION
	Capacitors	
C563	354721019	100 μ F,6.3V,Elect.
C571,C572	354761009	10 μ F,35V,Elect.
C577,C578	354721019	100 μ F,6.3V,Elect.
C585,C586	374723334	0.033 μ F \pm 5%,50V,Plastic
C587,C588	374724734	0.047 μ F \pm 5%,50V,Plastic
C595,C596	354761009	10 μ F,35V,Elect.
	Resistors	
R585,R586	4000131	0.22 ohm \times 2,2W+2W,Metal plate
R587-R590	452530824	8.2 ohm,1/2W,Metal
R597	452530824	8.2 ohm,1/2W,Metal
	Plug	
P611A	25055234	NPLG-3P218
	Wire traps	
JL571	25050280	NSCT-3P108
JL572	25050282	NSCT-5P110

tone CONTROL CIRCUIT PC BOARD (NAAF-4704-3)

CIRCUIT NO.	PART NO.	DESCRIPTION
	ICs	
Q401,Q402	22240247 or 22240293	BA15218N or NJM4558L-D
	Transistors	
Q403-Q406	2211945	2SK246-GR
	Diodes	
D401-D404	223205 or 223163	1SS270A or 1SS133
	Capacitors	
C401,C402	354761009	10 μ F,35V,Elect.
C405,C406	354744709	47 μ F,16V,Elect.
C407,C408	374721534	0.015 μ F \pm 5%,50V,Plastic
C411,C412	374721534	0.015 μ F \pm 5%,50V,Plastic
C413-C416	374721044	0.1 μ F \pm 5%,50V,Plastic
C417-C420	374721024	1000pF \pm 5%,50V,Plastic
	Variable resistors	
R393	5104225	N11RGLC250KWT22Z,Balance
R407	5104230	N14RLC100KWT22Z,Bass
R413	5104230	N14RLC100KWT22Z,Treble

VIDEO CIRCUIT PC BOARD (NAETC-4705-3)

CIRCUIT NO.	PART NO.	DESCRIPTION
	IC	
Q251	22240373	BA7625
	Transistors	
Q252-Q254	2213354	2SA933S-R
	Diodes	
D251	22380046 or 22380035	AM01Z or GP104003E

CAUTION:
 Replacement for transistor of mark *, if necessary must be made from the same beta group (HFE) as the original type.

CIRCUIT NO.	PART NO.	DESCRIPTION
	Capacitors	
C253	354780229	2.2 μ F,50V,Elect.
C252,C254	354724719	470 μ F,6.3V,Elect.
C255,C256	354780229	2.2 μ F,50V,Elect.
C258	354724719	470 μ F,6.3V,Elect.
C259	354721019	100 μ F,6.3V,Elect.
	Terminals	
P251	25045299	NPJ-3PDYE-158
P252	25045395	NPJ-2PDYE-221
	Wire trap	
JL251	25050529	NSCT-7P352
	Plug	
P261A	25055132Y	NPLG-2P116

VIDEO INPUT TERMINAL PC BOARD (NAETC-4706-3)

CIRCUIT NO.	PART NO.	DESCRIPTION
D281-D284	223205 or 223163	1SS270A or 1SS133,Diodes
P305	25045321	NPJ-3PDBL178,Terminal
P261	2009990281Y	NSAS-4P0409,Socket
P321	2009990125ULY	NSAS-6P0190,Socket

TUNER INPUT TERMINAL PC BOARD (NAETC-4707-3)

CIRCUIT NO.	PART NO.	DESCRIPTION
Q381	22240247	BA15218N,IC
C383,C384	354780339	3.3 μ F,50V,Elect. capacitors
P381	25045360	NPJ-2PDWH206,Terminal

NOTE: <D>:120V model only
 <P>:230V model only
 <Q>:240V model only
 <W>:Worldwide model only

SYSTEM CONNECTION

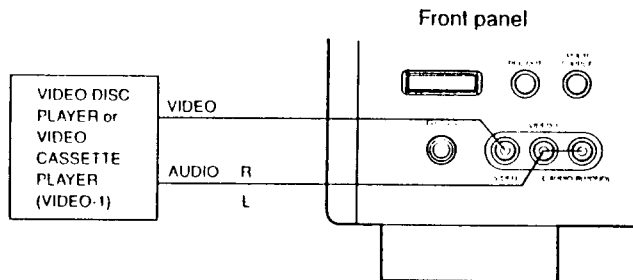
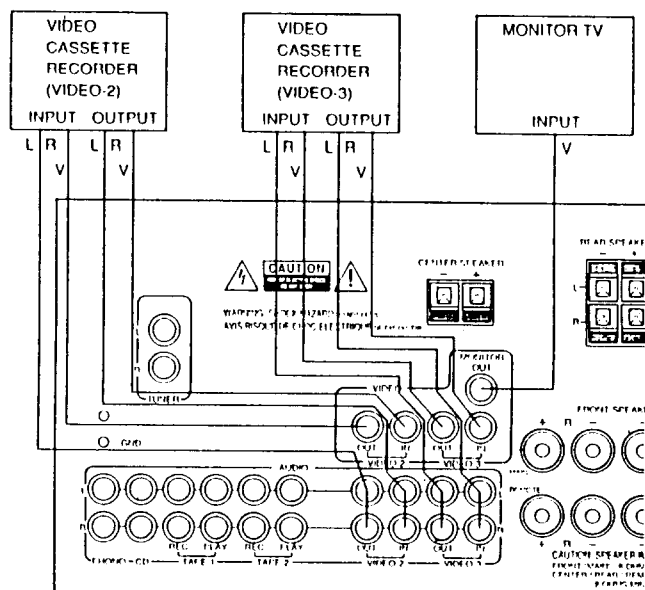
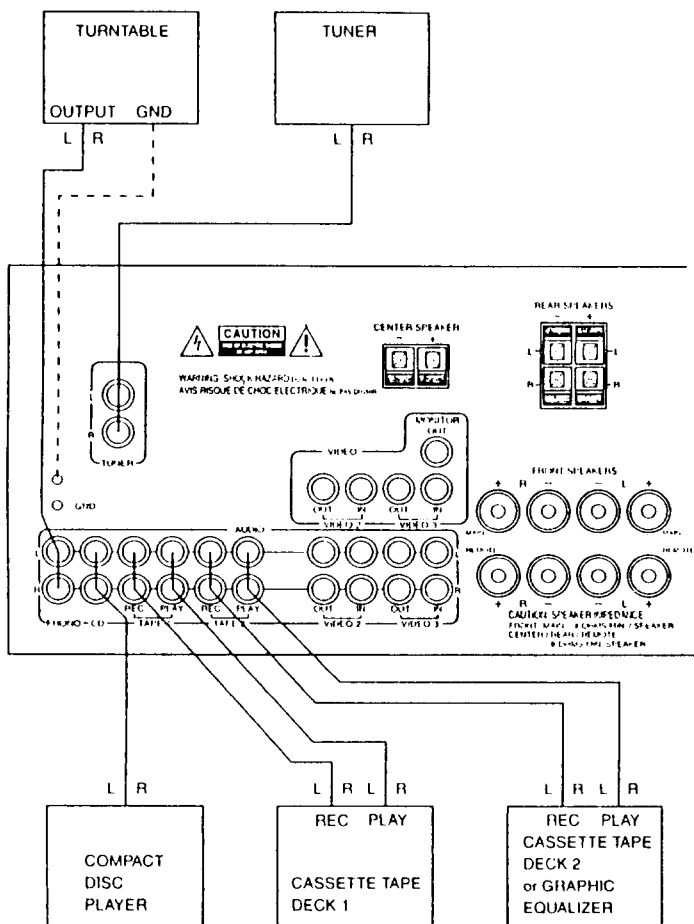

PACKING VIEW

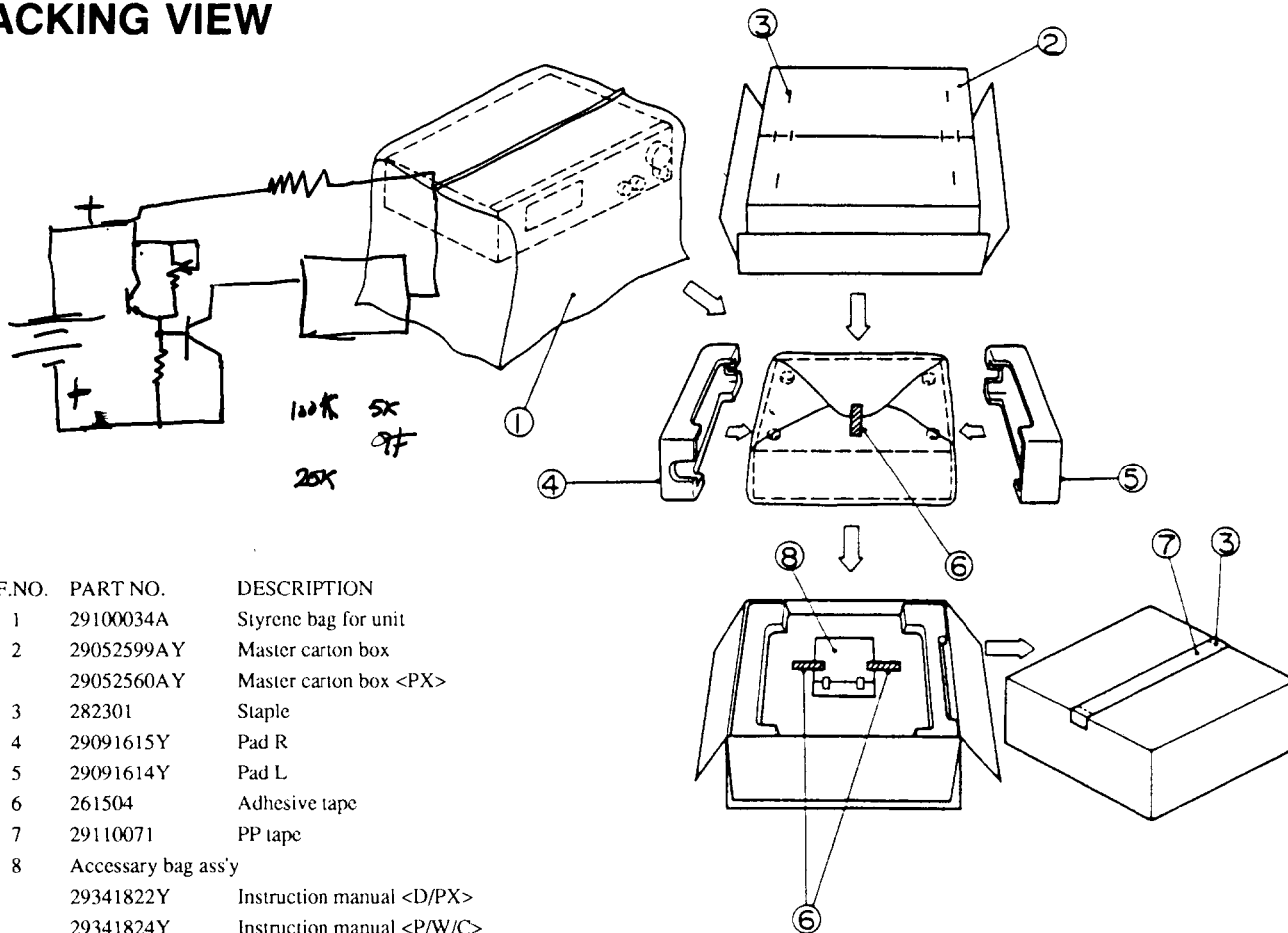

REF.NO.	PART NO.	DESCRIPTION
1	29100034A	Styrene bag for unit
2	29052599AY	Master carton box
	29052560AY	Master carton box <PX>
3	282301	Staple
4	29091615Y	Pad R
5	29091614Y	Pad L
6	261504	Adhesive tape
7	29110071	PP tape
8	Accessory bag ass'y	
	29341822Y	Instruction manual <D/PX>
	29341824Y	Instruction manual <P/W/C>
	29341845Y	Instruction manual <W>
	2010200	Connection cord
	3010054	UM-3,Two batteries
	24140255Y	RC-255S,Remote control transmitter <D/PX>
	24140252Y	RC-252S,Remote control transmitter <P/W>
	25055018	CV-K-1,Conversion plug <W>
	25055251	CV-CP,Conversion plug <PX>
	29365019A	Warranty card <N>
	29365020H	Warranty card <V>
	29365024A	Warranty card <F>
	29365021	Warranty card <PX>
	29358002J	Service station list <N/PX>
	29100097	Styrene bag for accessory
	29100094B	Styrene bag for warranty card <V>
	29100107	Styrene bag for warranty card <F>

NOTE: <D>:120V model only
 <P>:230V/240V models only
 <W>:Worldwide model only
 <N>:U.S.A. model only
 <V>:Germany model only
 <PX>:PX model only
 <C>:Canadian model only
 <F>:France model only

ONKYO CORPORATION

International Division: Onarimon Yusen Bldg., 23-5, Nishi-Shimbashi 3-chome, Minato-ku, TOKYO 105, JAPAN Tel: 03-3432-6987 Fax: 03-3436-6979

ONKYO U.S.A. CORPORATION

200 Williams Drive, Ramsey, N.J. 07446, U.S.A.
 Tel: 201-825-7950 Fax: 201-825-8150

ONKYO Europe GmbH

Hellersbergstrasse 4, W-4040 Neuss GERMANY
 Tel: 02101 12 00 75 Fax: 02101 10 33 06 TLX: 85 17 916 ONDU D

ONKYO FRANCE S.A.R.L.

Immeuble Le DIAMANT, Domaine Technologique De Saclay, 4 rue Rene Razel, 91892 SACLAY, FRANCE Tel: (1)69 41 35 10 Fax: (1)69 41 35 84



A-SV610PRO

Audio Video Control Amplifier

Instruction Manual

● *Congratulations on your purchase of the ONKYO A-SV610PRO Tuner-Amplifier.* ● *Please read this manual thoroughly before making connections and turning power on.* ● *Following the instructions in this manual will enable you to obtain optimum performance and listening enjoyment from your new A-SV610PRO.* ● *Please retain this manual for future reference.*

CONTENTS

Important safeguards	1
Precautions	2
Before using this unit	2
Features	3
Explanation	4
System connections	5
Control positions and names	8
Operations — playback	10
Operations — recording	12
Listening to devices connected to the A-SV610PRO in another room	14
Use of Surround mode	16
Troubleshooting guide	18
Specifications	18

“WARNING”

“TO REDUCE THE RISK OF FIRE OR ELECTRIC SHOCK, DO NOT EXPOSE THIS APPLIANCE TO RAIN OR MOISTURE.”

CAUTION:

“TO REDUCE THE RISK OF ELECTRIC SHOCK, DO NOT REMOVE COVER (OR BACK). NO USER-SERVICEABLE PARTS INSIDE. REFER SERVICING TO QUALIFIED SERVICE PERSONNEL.”



- The lightning flash with arrowhead symbol, within an equilateral triangle, is intended to alert the user to the presence of uninsulated “dangerous voltage” within the product’s enclosure that may be of sufficient magnitude to constitute a risk of electric shock to persons.



- The exclamation point within an equilateral triangle is intended to alert the user to the presence of important operating and maintenance (servicing) instructions in the literature accompanying the appliance.

- Sur les modèles dont la fiche est polarisée.

ATTENTION: POUR EVITER LES CHOCS ELECTRIQUES, INTRODUIRE LA LAME LA PLUS LARGE DE LA FICHE DANS LA BORNE CORRESPONDANTE DE LA PRISE ET POUSSER JUSQU'AU FOND.

- For models having power cords with a polarized plug.

CAUTION: TO PREVENT ELECTRIC SHOCK, MATCH WIDE BLADE OF PLUG TO WIDE SLOT. FULLY INSERT.

Important safeguards

1. **Read Instructions** – All the safety and operating instructions should be read before the appliance is operated.
 2. **Retain Instructions** – The safety and operating instructions should be retained for future reference.
 3. **Heed Warnings** – All warnings on the appliance and in the operating instructions should be adhered to.
 4. **Follow Instructions** – All operating and use instructions should be followed.
 5. **Water and Moisture** – The appliance should not be used near water - for example - near a bathtub, washowl, kitchen sink, laundry tub, in a wet basement, or near a swimming pool, and the like.
 6. **Carts and Stands** – The appliance should be used only with a cart or stand that is recommended by the manufacturer.
- 6A An appliance and cart combination should be moved with care. Quick stops, excessive force, and uneven surfaces may cause the appliance and cart combination to overturn.
- PORTABLE CART WARNING

S3: 25A
7. **Wall or Ceiling Mounting** – The appliance should be mounted to a wall or ceiling only as recommended by the manufacturer.
 8. **Ventilation** – The appliance should be situated so that its location or position does not interfere with its proper ventilation. For example, the appliance should not be situated on a bed, sofa, rug, or similar surface that may block the ventilation openings; or, placed in a built-in installation, such as a bookcase or cabinet that may impede the flow of air through the ventilation openings.
 9. **Heat** – The appliance should be situated away from heat sources such as radiators, heat registers, stoves, or other appliances (including amplifiers) that produce heat.
 10. **Power Sources** – The appliance should be connected to a power supply only of the type described in the operating instructions or as marked on the appliance.
 11. **Polarization** – If the appliance is provided a polarized plug having on blade wider than the other, please read the following information: The polarization of the plug is a safety feature. The polarized plug will only fit the outlet one way. If the plug does not fit fully into the outlet, try reversing it. If there is still trouble, the user should seek the services of a qualified electrician. Under no circumstances should the user attempt to defeat the polarization of the plug.

12. **Power-Cord Protection** – Power-supply cords should be routed so that they are not likely to be walked on or pinched by items placed upon or against them, paying particular attention to cords at plugs, convenience receptacles, and the point where they exit from the appliance.
13. **Cleaning** – The appliance should be cleaned only as recommended by the manufacturer.
14. **Nonuse Periods** – The power cord of the appliance should be unplugged from the outlet when left unused for a long period of time.
15. **Object and Liquid Entry** – Care should be taken so that objects do not fall and liquids are not spilled into the enclosure through openings.
16. **Damage Requiring Service** – The appliance should be serviced by qualified service personnel when:
 - A. The power-supply cord or the plug has been damaged; or
 - B. Objects have fallen, or liquid has been spilled into the appliance; or
 - C. The appliance has been exposed to rain; or
 - D. The appliance does not appear to operate normally or exhibits a marked change in performance; or
 - E. The appliance has been dropped, or the enclosure damaged.
17. **Servicing** – The user should not attempt to service the appliance beyond that described in the operating instructions. All other servicing should be referred to qualified service personnel.

Precautions

1. Warranty Card

The serial number is written on the rear panel of this unit. Copy the serial number and model number onto your warranty card and keep it in a safe place.

2. Recording Copyright

Recording of copyrighted material for other than personal use is illegal without permission of the copyright holder.

3. AC Fuse

The fuse is located inside the chassis and is not user serviceable. If power does not come on, contact your ONKYO dealer.

4. Care

From time to time you should wipe off the front and rear panels and the cabinet with a soft cloth. For heavier dirt, dampen a soft cloth in a weak solution of mild detergent and water, wring it out dry, and wipe off the dirt. Following this, dry immediately with a clean cloth. Do not use rough material, thinners, alcohol or other chemical solvents or cloths since these could damage the finish or remove the panel lettering.

5. Power

WARNING

BEFORE TURNING ON POWER FOR THE FIRST TIME, READ THE FOLLOWING SECTION CAREFULLY.

- Some models are designed for use only with the power supply voltage of the region where they are sold.
 - USA & Canadian models: AC120V, 60Hz
 - U.K. & Australian models: AC240V, 50Hz
 - Worldwide models: 120 and 220V switchable, 50/60Hz
- **Voltage Selector (Rear Panel)**
Worldwide models are equipped with a voltage selector to conform with local power supplies. Be sure to set this switch to match the voltage of the power supply in your area before turning the power switch on. Voltage is changed by sliding the groove in the switch with a screwdriver to the right or left. Confirm that the switch has been moved all the way to the right or left before turning the power switch on. Models without a voltage selector can only be used in areas where the power supply is the same as that of the unit.

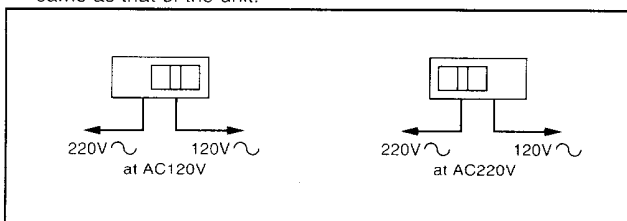

Before using this unit

1. Supplied Accessories

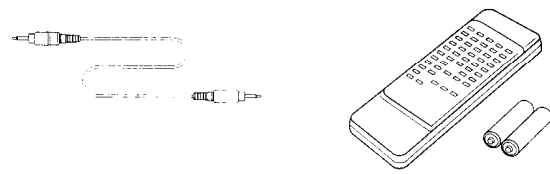

RI remote control cable × 1 Remote control transmitter × 1
Batteries × 2

2. Transmitter Battery Insertion

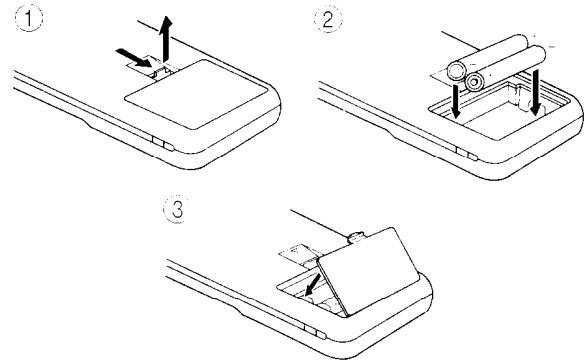

Precautions when using batteries

- The remote control transmitter is powered by two batteries. Before using this unit for the first time, insert the two batteries (included) as shown in the diagram.
- Average battery life is about one year. This period may be shorter depending on the frequency of use and environment (temperature and humidity) in which the remote control transmitter is used.
- If the remote control transmitter does not operate even though front panel controls function normally, the batteries should be replaced. Use only batteries listed in the following chart.

Type	Voltage	Size
Manganese	1.5V	AA R6 UM-3

NOTES:

1. Do not leave an expired battery in the case as it may leak or damage the battery case.
2. When inserting the batteries, be sure the (+) and (–) ends are properly aligned.
3. Do not use nickel-cadmium (rechargeable) batteries.
4. Do not use one specified (manganese) battery and one alkaline battery at the same time.
5. Replace both batteries at once; do not use one old and one new battery together.

Features

- **Enough Power to Pack a Wallop**

In stereo mode you get 125 watts of power to each of the front channels, driven into 8 ohms, with no more than 0.08 % THD. In terms of dynamic power, that's a whopping 240 watts per channel at 4 ohms. In surround mode, 70 watts drive the center channel, while 20 watts drive the rear channels.

- **Completely Discrete Output Stage**

Each of the five channels boasts completely discrete amplifier blocks to give you clear, dynamic sound from any source.

- **Dolby Pro-Logic Surround Sound System**

Creates a multi-dimensional soundstage with better channel separation, localization, imaging and dialogue that comes directly from center stage. And with built-in auto input balance, sound from the L/R channels always compliments each other. The result is sound effects comparable to that of high-class theaters.

- **Multiple Room Remote System and Multi Source Selector**

If you have an additional pair of speakers in another room, you can operate your A-SV610PRO from the other room (with the optional HR-10W remote sensor), as well as control non-ONKYO video components, such as your TV or VCR from another room (with optional HE-50AC emitter and HE-10 emitter head). You can also play different sources simultaneously for multiple-room entertainment.

- **Digital Delay and Delay-Time Variable Circuitry for Dolby Pro-Logic**

- **Auto Input Balance for Dolby Pro-Logic**

- **Input Selector for 3 Video and 5 Audio Sources**

- **Record Selector (Sound and Picture)**

- **Cassette and Video Tape Dubbing**

- **Selective Tone Control**

- **Mute Button and Sleep Timer (Operated by Remote)**

- **Battery-Free Backup System to Protect Memory Contents**

- **Motor-Driven 4-Ganged Volume Control**

- **Front Panel Video Input Terminal for Easy Camcorder, etc. Connection**

- **Eight Character Alphanumeric Dot Matrix Fluorescent Display**

- **Large, Tri-Point Vibration Absorbing Feet**

- **RI Compatible Remote Control Supplied**

Manufactured under license from Dolby Laboratories Licensing Corporation. Additionally licensed under one or more of the following patents: U.S. numbers 3,632,886, 3,746,792 and 3,959,590; Canadian numbers 1,004,603 and 1,037,877. "Dolby" and the double-D symbol  are trademarks of Dolby Laboratories Licensing Corporation.

Explanation

Surround System

Many motion pictures produced in the last decade have been released in "Dolby Stereo" sound, with music, dialogue, and panned effects coming from the 3-channel front soundstage, and surround effects and ambience emanating from the sides and rear of the theater. These four channels are encoded, or matrixed, into a two-channel DOLBY STEREO release, and decoded in the theater by a professional DOLBY STEREO MP (Motion Picture) decoder. These surround sound effects are "hidden" in the two-channel stereo movie release, and decoded in the theater by special Dolby equipment.

These same two-channel motion picture masters are used for production of stereo VHS, VHS Hi-Fi, Beta Hi-Fi, and stereo Laser Vision discs that you can buy or rent at your video store. The A-SV610PRO incorporates the Dolby Pro Logic Surround Circuit, which is designed to emulate the audience experience found in DOLBY STEREO theaters. Like DOLBY SURROUND, DOLBY PRO LOGIC SURROUND is capable of creating a multi-dimensional soundstage, but with the increased channel separation it gives a far greater sense of "movement" and sound localization. Just like in the theater, the addition of the active center channel ensures that all audience members hear dialogue coming from its on-screen sources regardless of seating position.

Since the A-SV610PRO is equipped with front amplifiers, center amplifier and rear (surround) amplifiers, Dolby Pro Logic Surround and Hall effects can all be produced. You can enjoy the feeling of a movie theater or concert hall in your own room. To reproduce these effects, rear (surround) speakers and center speaker are necessary. The placement of these speakers is important. You can experiment with various positions and locations to find the best placement for optimum sound quality in your room.

Examples of Speaker Placement

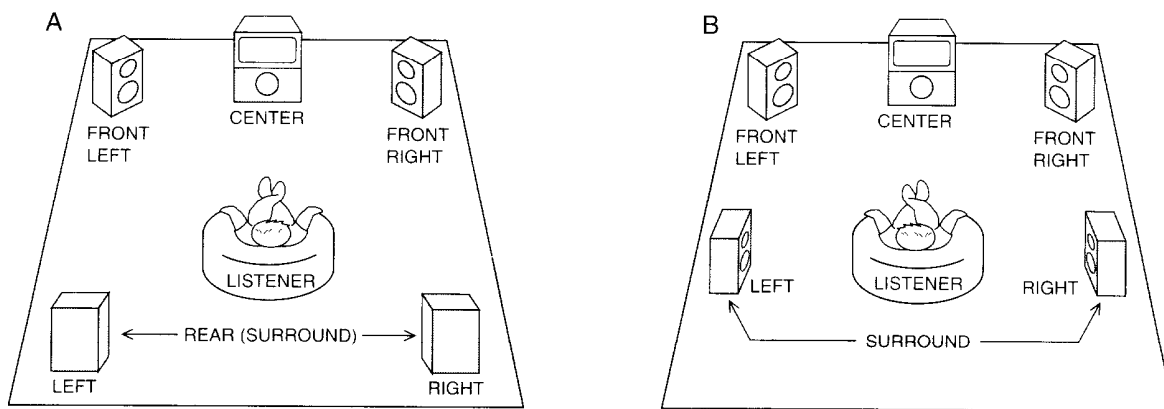

With the rear (surround) speakers facing the wall, the reverberation effect amplifies the "surround" effect for a more "live" sound. Try it and see!

● Dolby Pro Logic Surround

When using a video cassette tape or a video disc that have the DOLBY STEREO or DOLBY SURROUND trade mark, you can achieve the same kind of sound in your room that you experience in a movie theater.

In the Dolby Pro Logic Surround mode, three modes are available according to the type of center speaker used.

1. Normal: When a small speaker is used on the center channel, signals of 100 Hz or more are output from the center speaker, and signals of 100 Hz or less are split between the front L and R channels.
2. Wide band: When the center speaker is approximately the same size as the left and right speakers, it operates throughout the full frequency range.
3. Phantom: When no center speaker is used, the center channel signal is split between the front L and R speakers, producing the same results as found with a center speaker.

● Hall

The same kind of sound that you experience in a theater or concert hall and the natural expansion of sound can be achieved with a music source. Hall mode would be best suited to jazz and classical.

Multiple Room Remote System (MR)

The ONKYO HR-10(W) Remote Sensor (sold separately) greatly increases system flexibility. Used with your A-SV610PRO, the HR-10(W) allows you to control speakers even when you are not in the same room as the A-SV610PRO. In addition to basic functions like speaker on-off and volume and so on, you can also control most ONKYO tuners, CD Players, Cassette Decks and Digital Audio Tape Decks that use the (Remote Interactive) system. Adding an HE-50(AC) Remote Emitter (also available as an option) allows you to control even the non-ONKYO components in your home entertainment system from a separate room.

When the HE-50(AC) is being used to control more than one device from a distance but the infrared beams from the HE-50(AC) remote control transmitter alone will not reach these devices, connect an HE-10 (remote emitter head) to the HE-50(AC), and set it up to be aimed at the devices to be controlled. The HW-2 cable 6-1/2' (2m) is attached with the HE-10. Up to three HE-10 units can be used with this equipment.

System connections

- Do not plug in the cord until all connections have been made.

General

Switch the main power switch off before performing connections. Also be sure to perform left and right channel connections properly.

Note to CATV system installer:

This reminder is provided to call the CATV system installer's attention to Article 820-40 of the NEC, which provides guidelines for proper grounding and, in particular, specifies that the cable ground shall be connected to the grounding system of the building, as close to the point of cable entry as practical.

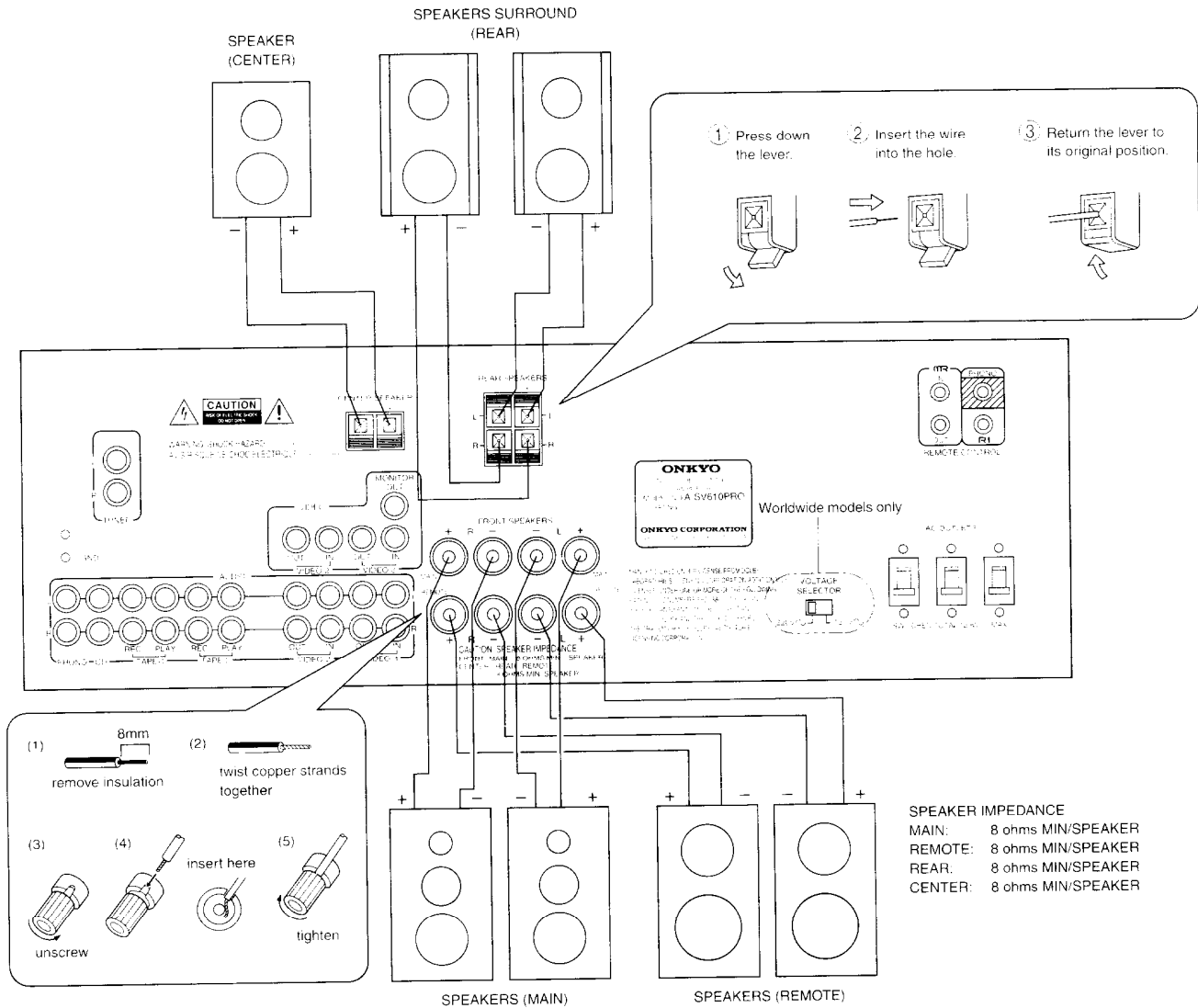

Speaker Connections (SPEAKERS)

- The speakers that are to be in the same room as the A-SV610PRO should be connected to the "MAIN" speaker terminals. Different set of speakers located in another room (or the same room) should be connected to the "REMOTE" speaker terminals. If you want to use the surround effects, connect the center speaker to the "CENTER" speaker terminals, and the rear (surround) speakers to the "REAR" speaker terminals.
 - When connecting speakers, proper polarity is important. Always connect the (+) terminal (red) on this equipment to the (+) terminal on the speaker and the (-) terminal (black) on this equipment to the (-) terminal on the speaker.
 - Do not connect a single speaker in parallel to the right and left channel output.
 - Use speaker cables that have a low impedance and that are as short as possible.
- Attach speaker cables to the rear panel speaker terminals with care, being sure that connections are made firmly and that there is no possibility of a short circuit occurring.

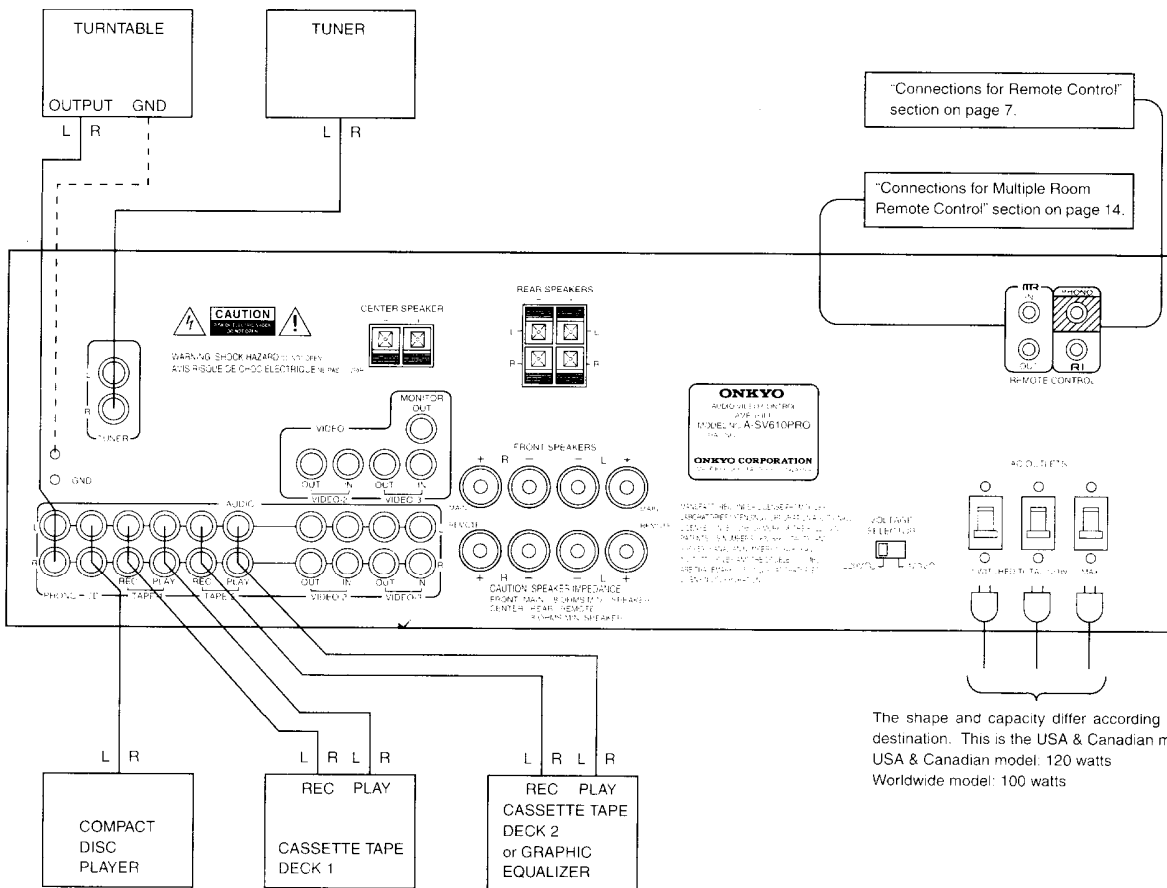

The shape and capacity differ according to the destination. This is the USA & Canadian model. USA & Canadian model: 120 watts. Worldwide model: 100 watts

AC Outlets

These outlets are switched on and off by the Power button on the front panel and remote control transmitter. Capacity is total 120 watts. (Worldwide model: 100 watts)

Tuner Connections

Connect an FM/AM tuner to the tuner input jacks. Be sure the left and right channels are connected properly.

Turntable Connections (PHONO)

Connect the output of the turntable to the PHONO jacks. Be sure to connect the ground (earth) lead wire from the turntable to the ground terminal (GND). Lack of proper ground connection will cause hum. Turntables not provided with GND wires do not need to be connected.

1. Place the turntable on a firm shelf or deck free from vibrations (especially those generated by the speaker system). If the turntable is permitted to pick up such unwanted vibrations, not only with the performance of the unit drop, but distortion in the bass frequencies and howling in the speakers may also occur.
2. Check the turntable instruction manual for any other precautions.
3. The loud noises that occur when connecting or disconnecting, replacing the cartridge or lowering the tonearm could damage the speakers. Always turn the power switch off before making connections.

Compact Disc Player or Other Component Connections (CD)

Connect the output of the CD player or an additional audio component to the CD jacks. An ONKYO CD player with remote control that has the **RI** mark can be operated by the A-SV610PRO. (Please refer to "Connections for Remote Control".) For more details, refer to your CD player instruction manual.

Tape Deck and Graphic Equalizer Connections (TAPE-1, TAPE-2)

1. This unit has facilities for two tape decks. If you are using only one tape deck, connect it to the TAPE-1 jacks. If you have two tape decks, connect one to the TAPE-1 jacks and the other to the TAPE-2 jacks.
2. Connect the output of the tape decks to the TAPE-1 and TAPE-2 "PLAY" jacks. Connect the input of the tape decks to the TAPE-1 and TAPE-2 "REC" jacks of the unit. For more details, refer to your tape deck instruction manual.
3. To connect a graphic equalizer, too, use the TAPE-2 jacks and connect the second tape deck to the tape jacks of the equalizer. (See the figure)

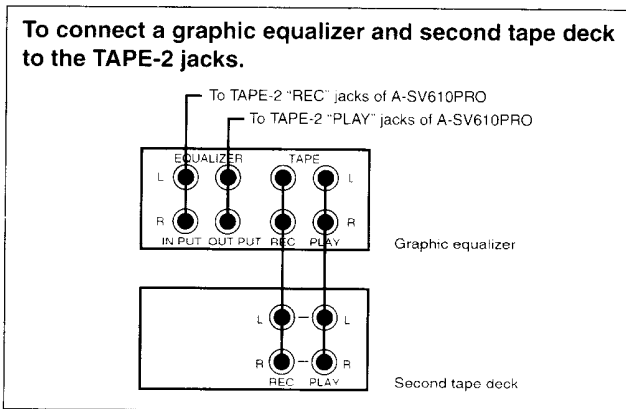

4. If you have an ONKYO tape deck with the **RI** remote control jack, connect it to the TAPE-1 jacks. Please refer to the section "Connections for Remote Control" regarding connection of the remote control cable.

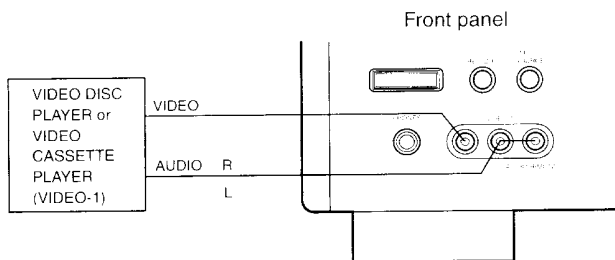
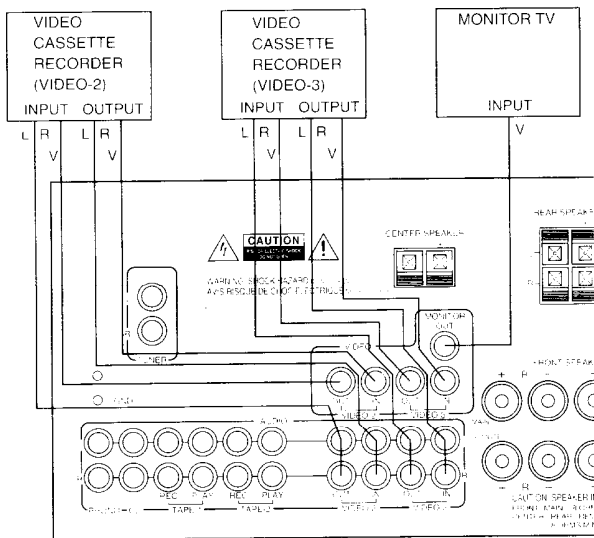

TV Connections (MONITOR)

1. Connect the TV VIDEO input to the A-SV610PRO "MONITOR OUT" jack. There is no need to perform an audio connection since sound will be sent directly from the A-SV610PRO to the speaker systems.
2. The A-SV610PRO does not have an RF converter. Therefore, it can be used with only a monitor TV equipped with a video input jack.

Video Disc Player (or Video Cassette Player) Connections (VIDEO-1)

Use the VIDEO-1 jacks of the front panel. Connect the VIDEO output of the video disc player to the A-SV610PRO VIDEO-1 "VIDEO" jack and the AUDIO output to the VIDEO-1 "AUDIO" jacks. The VIDEO-1 jacks are only for playback, there is no REC jack. If the audio output from the video unit is monaural, connect to R (MONO) jack. For more details, refer to the video disc player instruction manual.

Video Cassette Recorder Connections (VIDEO-2, 3)

1. Connect the VIDEO output of the VCR to the rear panel (VIDEO) VIDEO-2, 3 "IN" jack and the VIDEO input of the VCR to the rear panel (VIDEO) VIDEO-2, 3 "OUT" jack. Then connect the AUDIO output of the VCR to the (AUDIO) VIDEO-2, 3 L and R "IN" jacks. Finally, connect the AUDIO input of the VCR to the (AUDIO) VIDEO-2, 3 L and R "OUT" jacks.
2. When using a playback-only VCR, only the output connections need to be performed.
3. For more details, refer to the VCR instruction manual.

Connections for Remote Control (REMOTE CONTROL)

NOTE:

Of the ONKYO tuners, turntable, cassette decks, CD players, etc. that can be remote controlled, some models have the **RI** mark and some do not. (**RI**: Remote Interactive)

A tuner, cassette tape deck, compact disc player and turntable that have the ONKYO **RI** mark can be operated, using the accessory remote control transmitter. (**RI**: Remote Interactive)

Insert the accessory **RI** remote control cable plug attached to the ONKYO turntable with the **RI** mark into the PHONO of the A-SV610PRO's REMOTE CONTROL. To use an ONKYO compact disc player and cassette tape deck and tuner with the **RI** mark, insert the accessory remote control cable plug into the **RI** jacks. As far as connecting sequence is concerned, it doesn't matter whether the cable is connected from the A-SV610PRO to tuner or to the cassette tape deck or to the compact disc player. The connecting sequence is fixed only for the turntable. The remote control transmitter is operated by facing it towards the remote control sensor of the A-SV610PRO.

- ONKYO turntables that can be remote controlled but do not have the **RI** mark. This equipment has a 7-pin DIN jack on the rear panel. Connect this jack and the jack on the rear of the A-SV610PRO with the special cable for this purpose, which is sold separately.

NOTES:

1. To enable remote control operation, the audio connection cables and remote control cable should be connected between the units.
2. The REMOTE CONTROL units differ according to the destination; some have two **RI** terminals and no PHONO terminal. The turntable cannot be connected to this type of remote control. The upper and lower remote control jacks perform the same function.

Connection example

This illustration shows the standard way of connection the various models.

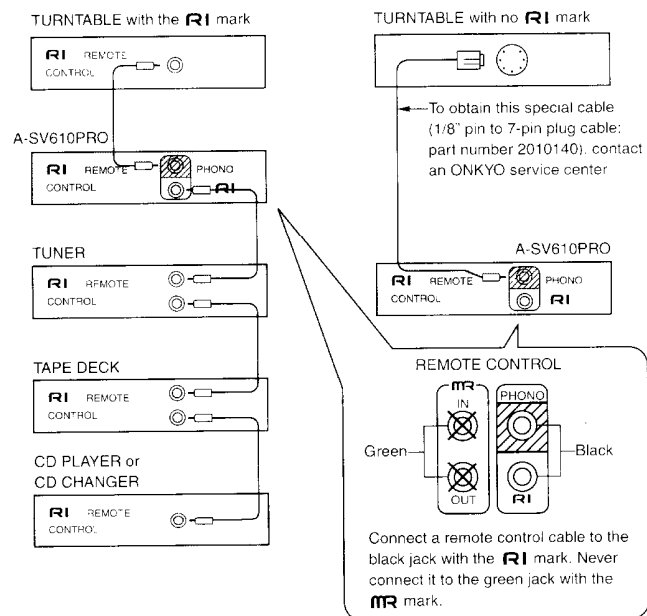

An **RI** remote control cable equipped with a 1/8" (3.5mm) diameter miniature two-conductor phone plug is attached to the A-SV610PRO and to any turntable, tuner, or compact disc player, with the **RI** mark.

Control positions and names

Front panel

For more information about buttons or controls, turn to the page number listed in the [].

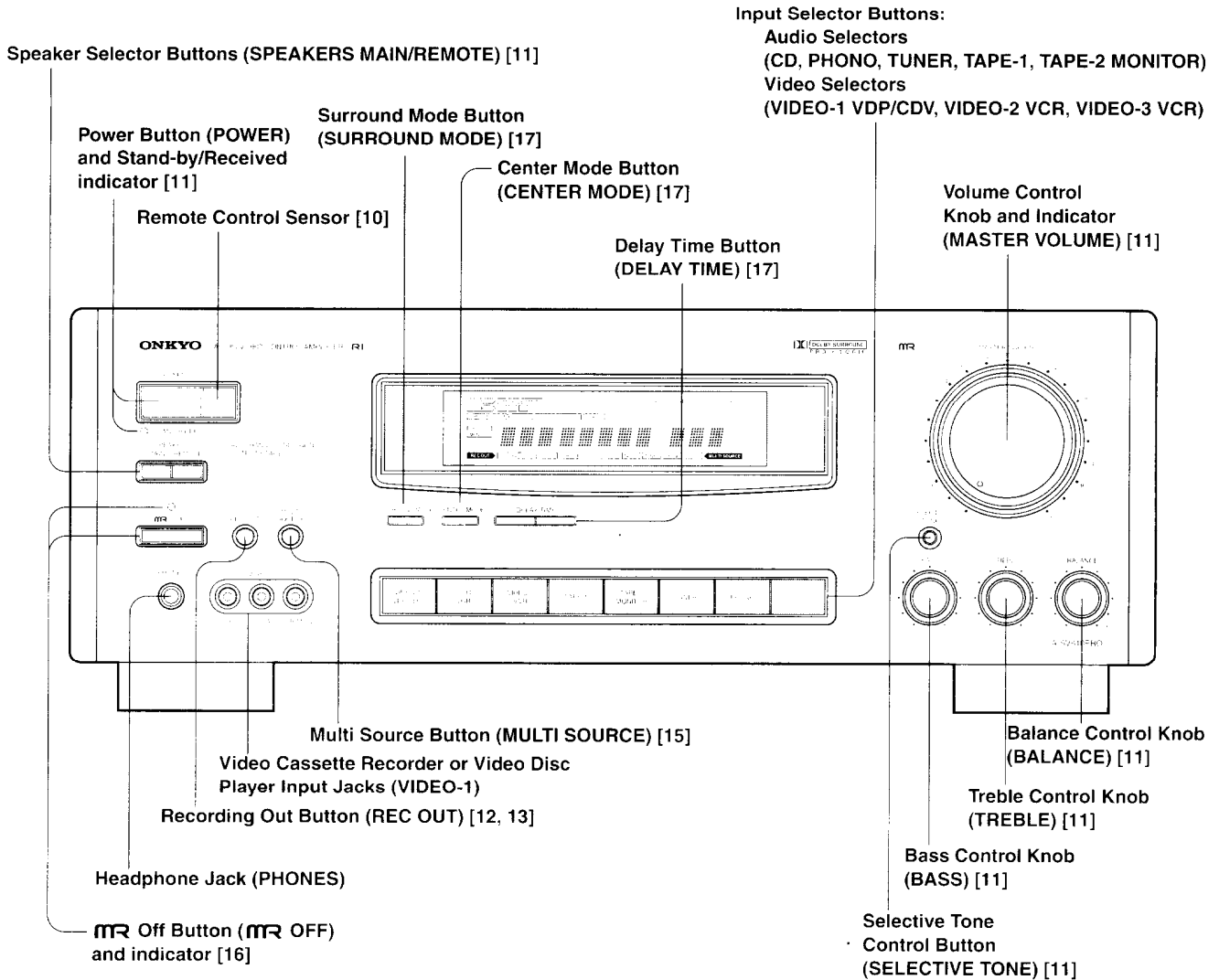

Display and indicators

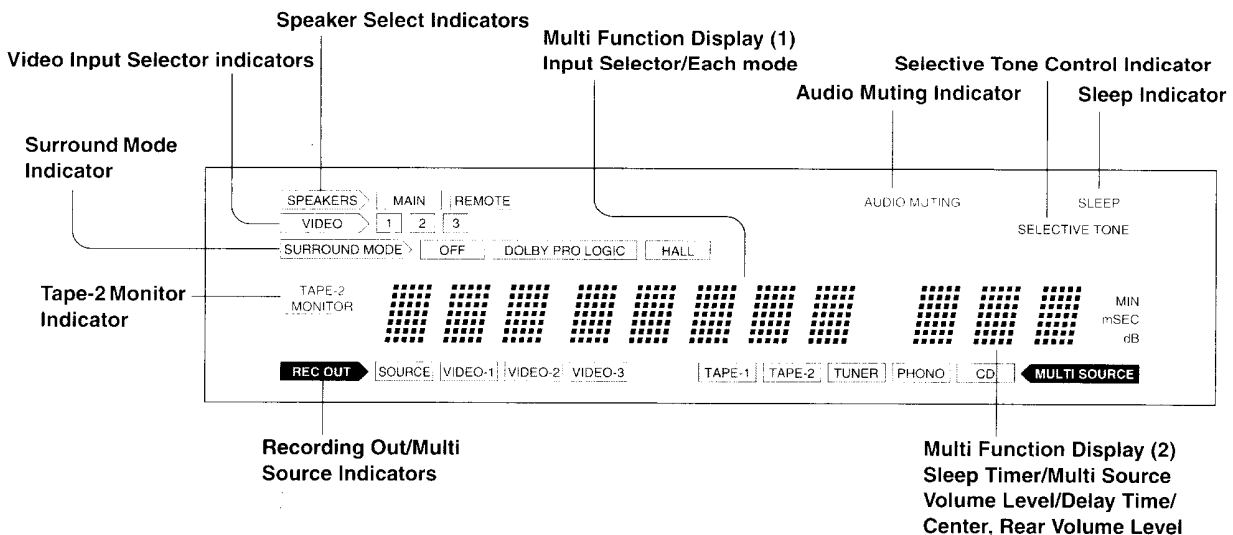

Remote control transmitter RC-255S

- Indicates buttons for operating this unit:

Power Button (POWER) [11]

Input Selector Buttons

(CD, PHONO, TUNER, VIDEO-1, VIDEO-2, VIDEO-3, TAPE-1, TAPE-2)

Sleep button (SLEEP) (Remote control transmitter only)

Press to set the power off timer. The sleep timer is a function which button off the power to the system from the time it is set. When this button is pressed, "90 MIN" is displayed for 5 seconds, and the power goes off 90 minutes later. Each time the button is pressed during 5 seconds, the timer setting changes, by 10 minute intervals, such as 80, 70, 60 While the sleep timer is operating, the [SLEEP] indicator is lit. If the sleep button is pressed during this time, the amount of time remaining on the sleep timer is displayed, and if the button is pressed during that display, 10 minutes will be subtracted from that time. If the button is pressed when the panel display shows 10 minutes or less, the sleep timer is cancelled, and the power is not turned off.

Speaker Selector Buttons (SPEAKERS MAIN/REMOTE) [11]

Multi Source Button (MULTI SOURCE) [15]

Test Tone Button (TEST)

This operates when Dolby Pro Logic Surround mode has been selected as the SURROUND MODE. Pink noise is produced in order to adjust the volume levels used by the Front, Center, and Rear speakers. Please follow the procedure described above to do this matching. Press the TEST button again after finishing adjustment.

Multi Source Level Up/Down Buttons (MULTI SOURCE UP/DOWN)

These buttons can be used to adjust the level of the speakers connected to the "REMOTE" speaker terminals (perhaps in another room) when the MULTI SOURCE mode is selected (the [MULTI SOURCE] indicator is lit). When one of the buttons is pressed in the Multi Source mode the display shows the level for two seconds. The indication for the Sub Room output level ranges from the minimum of (---dB), -78, -77 ... -1, to the maximum of (0 dB). Indications include *MULTI* for multi source level. These level settings can be memorized.

Surround Mode Button (SURROUND MODE) [17]

Delay Time Button (DELAY TIME) [17]

Audio Muting Button (MUTING)

This button temporarily switches off the sound from the speaker or headphone. Pressing this button will operate the A-SV610PRO audio muting circuit. The audio muting indicator "MUTING" will flash. Pressing the button again or using the POWER button on the remote control transmitter to turn the power on will turn off the audio muting.

- * Pressing this button does not mute the sound of the multi source. Press the SPEAKERS REMOTE button to mute the sound of the multi source.

Center Level Up/Down Buttons (CENTER LEVEL UP/DOWN)
Rear Level Up/Down Buttons (REAR LEVEL UP/DOWN)

These buttons are used to adjust the volume in the Surround mode. When one of the buttons is pressed in the Surround mode, the display shows the level for two seconds. For the Surround mode, the indication for the center or rear ranges from the minimum of (---dB), -60, -40 ... 0, +1, ... to the maximum of (+12 dB). These level settings can be memorized separately for Dolby and Hall.

Volume Buttons (VOLUME UP/DOWN) [11]

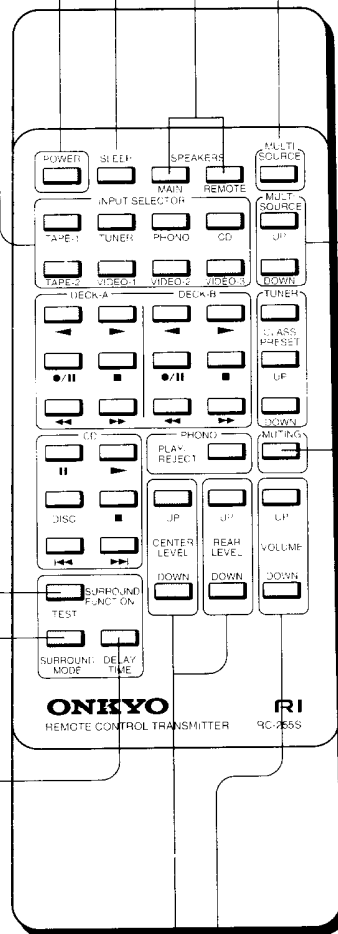

Operation of ONKYO components connected to this unit

When using the **RI** remote control cable for connecting ONKYO products provided with the **RI** mark, the functions mentioned below can be operated with remote control transmitter RC-255S which is provided with this unit. Please see page 7 for the connections details.

Tape Operation Buttons (DECK-A, DECK-B)

These buttons control ONKYO double cassette tape decks that can be remote controlled. Use the DECK-B buttons to control single cassette tape decks with the **RI** mark.

- /|| : When this is pressed, the recording stand-by mode is entered.
- ▶ : The tape plays, moving from right to left, or, in the recording stand-by mode, recording begins.
- : Interrupts all operations.
- ◀ : The tape plays, moving from left to right, or, in the recording stand-by mode, recording begins.
- ◀◀ : Fast forward from right to left.
- ▶▶ : Fast forward from left to right.

CD Operation Buttons (CD)

These buttons are used to operate an ONKYO CD player with the **RI** mark.

- ▶ : Press this button to play the CD player.
- || : Press this button to pause the CD play back. To resume disc play, press the PLAY button.
- DISC : Press to use for sequential selection of discs in the order they were loaded on the CD changer.
- : Press this button to stop the CD player.
- ◀◀ : Press this button to go back to the beginning of the current track and again to skip back to the previous track.
- ▶▶ : Press this button to skip to the next track.

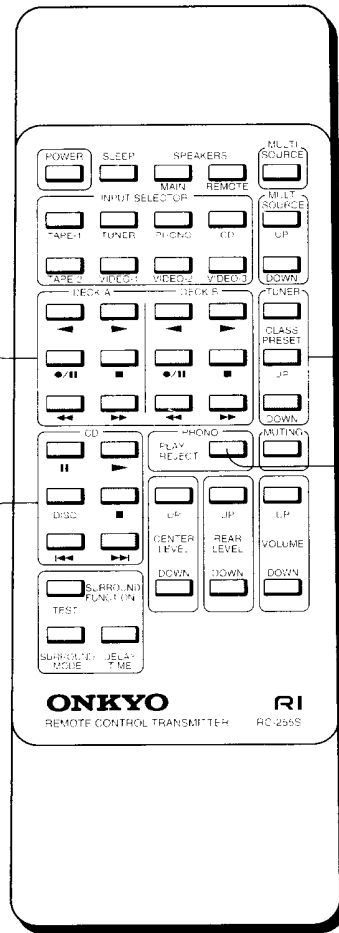

Tuner Operation Buttons

CLASS : This button is used for selecting the class of the stations that can be selected from the memory.

PRESET UP/DOWN : When the UP or DOWN button is pressed, the next higher or lower memory channel is recalled. Each time UP or DOWN button is pressed, the following memory channel in the corresponding direction is recalled. If the button is held down the memory channel will increase or decrease continuously until button is released.

Phono Operation Button (PLAY/REJECT)

This button is used to operate the turntable. The phono operation button can be used only when the PHONO input selector button has been pressed. Each time the phono operation button is pressed, the remote control transmitter alternately emits the play or reject command.

1. Remove the batteries if the remote control transmitter is not going to be used for a long time.
2. The batteries of the remote control transmitter must be replaced periodically.
3. This unit uses infrared rays. Therefore, commands may not be received properly if the front panel of this unit is exposed to bright light. To prevent this from occurring, place this unit so that it is not directly exposed to bright light.
4. If this unit is placed inside an audio rack behind a glass door, the door should not have colored glass or have any decorations on it, since this could shorten the range or prevent commands from being received.
5. Use of other infrared remote control devices in the same room may cause interference.
6. The transmitter operates up to a distance of about five meters (16 feet). The transmitting window must always be pointed at the reception window when a command is sent to the A-SV610PRO.
7. If this remote control transmitter does not operate properly, confirm that the batteries are not dead. If the problem persists, contact your ONKYO Service Center.

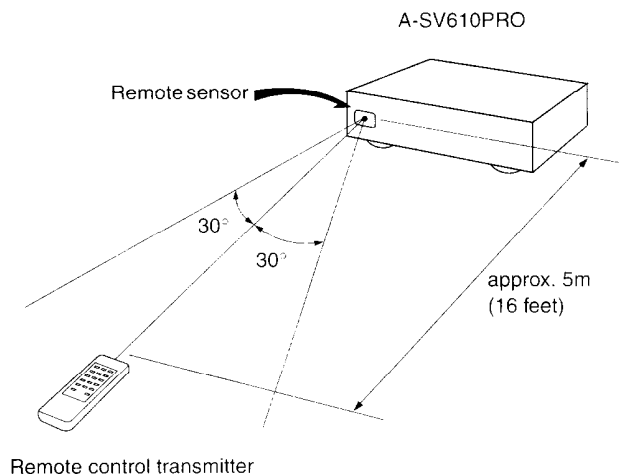

Operations — playback

To listen to your favorite Source

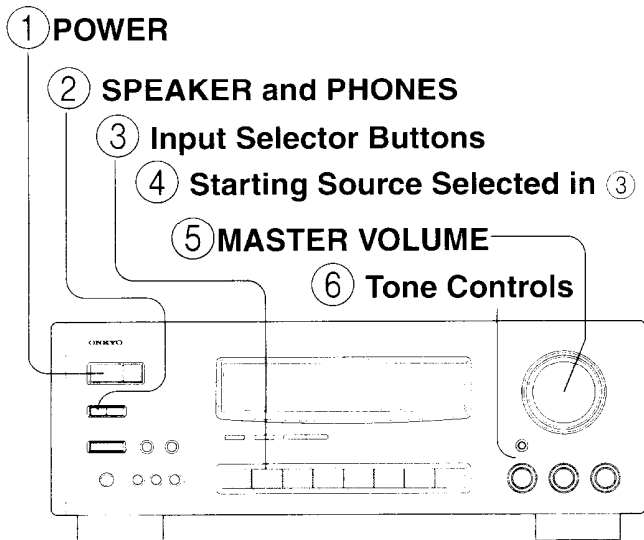

1. Press the POWER button to turn on the power.
2. Press the MAIN button of the speaker selector buttons. The **MAIN** indicator will be lit.
When using headphones, use the jack located under the **MR OFF** button. Stereo headphones with a standard binaural plug can be connected here. (Sound from the front MAIN speakers is output.) The sound from the headphones in the Surround Mode may be different from that which is obtained from speakers. The sound in the headphones may seem relatively far-away.
3. Press one of the desired Input Selector button (CD, PHONO, TUNER, TAPE-1, TAPE-2 MONITOR, VIDEO-1, 2, 3).
Make sure that the connections between the input sources are correct.
 - Confirm that the TAPE-2 MONITOR indicator is off when a source other than the TAPE-2 has been selected. Also check the audio muting is off.
4. Start play of the selected input source.
 - Follow the operating instructions of that unit.
5. Adjust the MASTER VOLUME Control knob to the appropriate level.
6. Adjust the Tone Controls to obtain the desired tone setting.

NOTE:

After selecting VIDEO-1 or VIDEO-2, or VIDEO-3 you can display the images of the selected video source while listening to the sound of another source. (CD, PHONO, TUNER, TAPE-1 or 2) In such case, the setting of the video selector button is indicated by the lit video input selector indicator.

Memory Preservation

This unit does not require memory preservation batteries. A built-in memory power back-up system preserves the contents of the memory during power failures and even when the unit is unplugged. The unit must be plugged in in order to charge the back-up system.

The memory preservation period after the unit has been unplugged varies depending on climate and placement of the unit. On the average, memory contents are protected over a period of a few weeks after the last time the unit has been unplugged. This period is shorter when the unit is exposed to a highly humid climate.

Explanation of the buttons

■ Power button (POWER) and Stand-by/Received indicator

The Stand-by/Received indicator comes on when the AC power cord for this unit has been inserted in an outlet. This indicates that the A-SV610PRO is standing by for operation. Pressing the POWER button or remote control POWER button, the main unit will come on, and power will be supplied from the AC outlet to the rear panel. This indicator then goes off. The indicator also lights when a signal is received from the remote control unit.

■ Speaker Selector buttons (SPEAKERS MAIN/REMOTE) and indicators

You can operate the SPEAKER SELECTOR from the front panel or with the remote control. When the MAIN and/or REMOTE is ON, the MAIN, REMOTE of the SPEAKER indicator will be lit.

- MAIN speakers button: The front speakers connected to the "MAIN" speaker terminals and the speakers connected to the "CENTER", and "REAR" speaker terminals can all be switched on or off at the same time.

- REMOTE speakers button: The source you selected using the MULTI SOURCE will be output from the REMOTE speakers. When you select the MULTI SOURCE mode, the **MULTI SOURCE** indicator will be lit, then you can switch the speakers connected to the "REMOTE" speaker terminals on or off. However, they cannot be turned on in a mode other than the Multi Source mode.

When the REC OUT mode is selected, or during surround playback, these speakers will be automatically switched off.

■ Master Volume Control Knob (MASTER VOLUME)

Use the MASTER VOLUME control knob to adjust the volume of the front main, center and rear (surround) speakers, at the same time. Turn clockwise to increase the volume level. The volume can be adjusted manually and by the remote control transmitter's VOLUME UP/DOWN buttons. The MASTER VOLUME control knob rotates when the volume is adjust by remote control. When you adjust the volume with the remote control check the level by looking at the indicator on the knob as it rotates. For fine adjustment of center and rear speaker volume in comparison to front speaker volume, use the remote control transmitters CENTER LEVEL UP/DOWN or REAR LEVEL UP/DOWN buttons. You can adjust the level of the REMOTE speakers by using the only UP/DOWN buttons of the MULTI SOURCE LEVEL on the remote control.

Tone and Balance Controls

■ Bass Control Knob (BASS)

Adjust to strengthen or weaken bass response. (Not effective for the center, rear speakers and multi source signal.)

■ Treble Control Knob (TREBLE)

Adjust to strengthen or weaken treble response. (Not effective for the center, rear speakers and multi source signal.)

- * TREBLE and BASS are effective for the L and R of the front speakers. The best effect from DOLBY PRO LOGIC SURROUND can be obtained when equal settings are used for the sound from the L/R front speakers and the sound from the center speaker for the middle and treble ranges.

■ Selective Tone Control button (SELECTIVE TONE) and indicator

Switching on this button lights up the indicator and creates a clear reproduction quality of the ultra low frequencies and high frequencies. (Not effective for the rear speakers and multi source signal.)

■ Balance Control Knob (BALANCE)

Use the Balance Control Knob (BALANCE) to adjust the relative volume levels of the left and right of MAIN speaker systems. This adjusts the relative volume level of the front MAIN speaker systems.

Operations — recording

Tape Recording

With the A-SV610PRO you can perform recording while listening to the sound of another source through speakers or headphones. Make all connections between the tape deck and the unit as shown in the System Connections diagram.

- When recording a tape while the multiple room remote control is connected, turn on **MR OFF** (the **MR OFF** indicator will light) to disable remote control operation from other rooms.

■ Recording and dubbing to a tape deck connected to TAPE-1

(A) When recording the source you are listening to

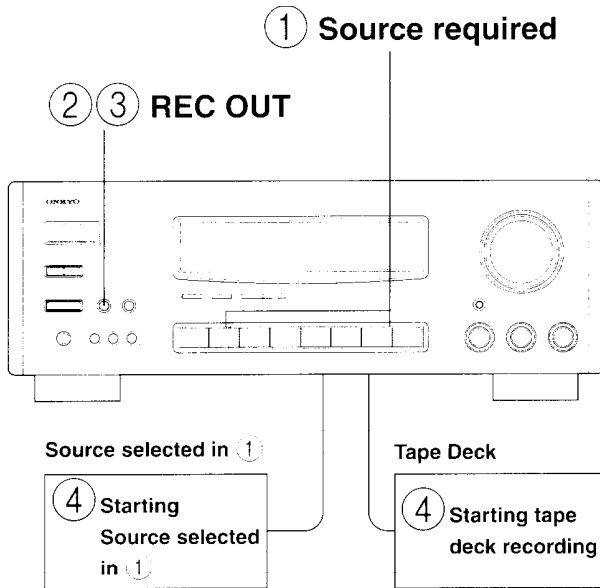

(B) When recording a source different from the one you are listening to

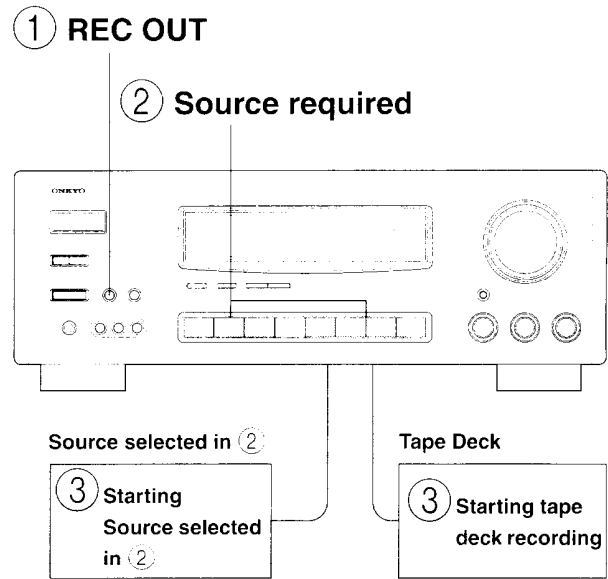

- 1 Press the input selector button to select the source to be recorded. (Other than TAPE-1)
- 2 Press the REC OUT button.
 - **REC OUT** on the display flashes for 8 seconds.
- 3 Press the REC OUT button again while the **REC OUT** indicator is flashing.
 - **REC OUT** and **SOURCE** will light, and the indication of the source selected by the input selector button will be marked with a red frame.
- 4 Start the device selected in step 1, while setting the tape deck connected to TAPE-1 to recording mode.
 - Set the proper recording level using the controls on the tape deck used for recording. Never change the positions of any controls (bass, treble, etc.) on this unit during recording and dubbing operations.

NOTES:

- Pressing the input selector button during recording will change the source being recorded.
- When the TAPE-2 MONITOR indicator is on, only TAPE-2 can be recorded and if the input selector is changed, the red frame of TAPE-2 will not change.

- 1 Press the REC OUT button.
 - **REC OUT** on the display will flash for 8 seconds.
- 2 Press the input selector button for the source to be recorded while the **REC OUT** indicator is flashing. (Other than TAPE-1)
 - **REC OUT** will light and the indication of the source selected will be marked with a red frame. This source will be output from the REC OUT jacks of TAPE-1, VIDEO-2 or VIDEO-3. The source you are listening to does not change.
- 3 Start the source device selected in step 2, and start recording on the tape deck connected to TAPE-1.

■ **Recording and dubbing to a tape deck connected to TAPE-2**

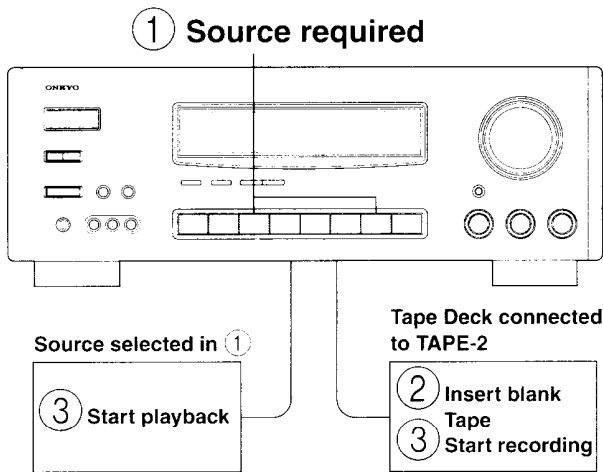

1. Press the input selector button of the source to be recorded. (Other than TAPE-2)
2. Put a blank tape in the tape deck connected to TAPE-2.
3. Start playing back the device selected in step 1, and start recording on TAPE-2.
 - When the TAPE-2 MONITOR indicator is off, the source signals can be monitored through the speakers or the headphones. If tape deck 2 has three heads, the just-recorded signals can be monitored (when the TAPE-2 MONITOR indicator is on). Refer to the tape deck instruction manuals for more details.
 - Set the recording level using the controls on the tape deck used for recording. Never change the positions of any controls (bass, treble, etc.) on this unit during recording and dubbing operations.

■ **VCR recording**

Data can be recorded from Video Disc Players, Video camcorders, and Video Cassette Recorders to Video Cassette recorders connected to VIDEO-2, 3. Connect the VCR to VIDEO-2, and/or VIDEO-3.

(A) **When recording the source being played back**

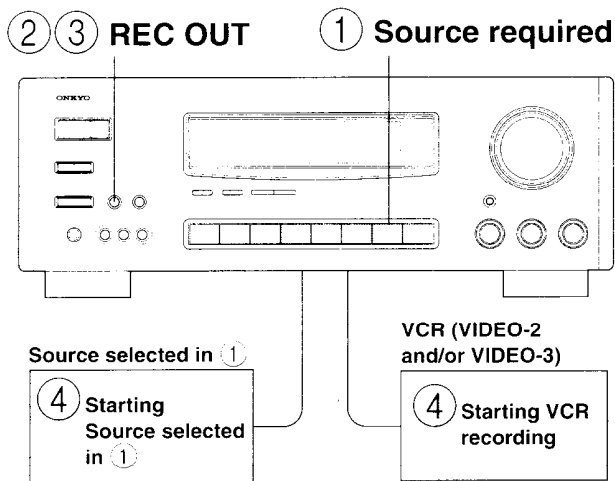

1. Select the source to be recorded with the input selector button.
2. Press the REC OUT button.
 - REC OUT on the display will flash for 8 seconds.
3. Press the REC OUT button again while the REC OUT is flashing.
 - REC OUT and SOURCE will light and the source selected with the input selector will be marked with a red frame.
4. Start the source selected in step 1, and start recording the VCR connected to VIDEO-2 and/or VIDEO-3.

■ **Using the Graphic Equalizer**

1. Connect the graphic equalizer to the TAPE-2 jacks on the rear panel. (See page 6)
2. If a second tape deck is used, connect it to the tape jacks on the graphic equalizer.
3. Press the TAPE-2 MONITOR button.
 - Follow the graphic equalizer operating instructions.
 - To record an equalized signal, use tape deck 2 (connected to the equalizer) for recording.

(B) **When recording a source different from the one being played back**

1. Press REC OUT button.
 - REC OUT on the display will flash for 8 seconds.
2. Press the input selector button of the source to be recorded while the REC OUT indicator is flashing.
 - REC OUT will light, and the source selected will be marked with a red frame.
3. Start the source selected in step 2, and start recording the VCR connected to VIDEO-2 and/or VIDEO-3.

■ **Mixing video and audio for VCR recording**

1. Press the Input Selector button to select the video equipment (VIDEO-1, 2, 3) to be used when playing the video.
2. Press the REC/PAUSE button on the VCR (VIDEO-2 or 3) that will be doing the recording.
3. Press the REC OUT button and Input Selector button (CD, PHONO, TUNER, TAPE-1, TAPE-2) to select the audio source.
 - The picture will be left as is. Only the audio will be changed.
4. Start operation of the equipment.
 - The picture will be recorded from the video source, and the sound from the audio source.

Listening to devices connected to the A-SV610PRO in another room

- A-SV610PRO allows you to listen to the desired performance in another room (sub room) while listening to the playback of a device located in the main room. To do this, connect the speakers in another room to the FRONT SPEAKERS REMOTE terminals on the A-SV610PRO.
- Remote control from another room can be done by employing the ONKYO multiple room remote system (MR). Refer to the connections for multiple room remote control. Be sure to operate the remote control unit directing to the remote sensor unit HR-10.
- The following steps (except step 1.) can be performed using the remote control unit. It is recommended that the adjustments described below be done in the main room in advance, since it is not possible to operate the remote control unit in another room while watching the display of the A-SV610PRO.

Connections for Multiple Room Remote Control

(A) When using only the HR-10 (Option) to control A-SV610PRO in the main room from another room, connect them as shown in Fig. 1.

In this case, ONKYO tuner, power amplifier, CD player and cassette tape deck bearing the **RI** mark connected to the A-SV610PRO can be controlled.

Fig. 1

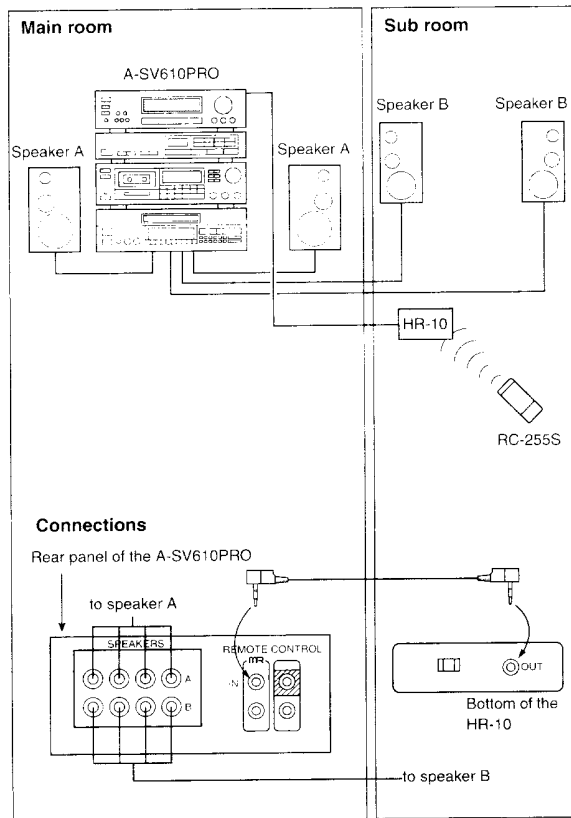

(B) A connection example using the HR-10 (Option) and HE-50 (AC) (Option) to control components in the main room from another room is shown in Fig. 2.

If all the components can not be controlled by the HE-50(AC) alone because they are installed at various places in the main room, use the remote emitter head HE-10 (Option). In this case, if components possess infrared remote control feature, they can be controlled even if they are not ONKYO products.

NOTE:

When using HE-50(AC), the HE-50 or HE-10 should also face the A-SV610PRO.

Fig. 2

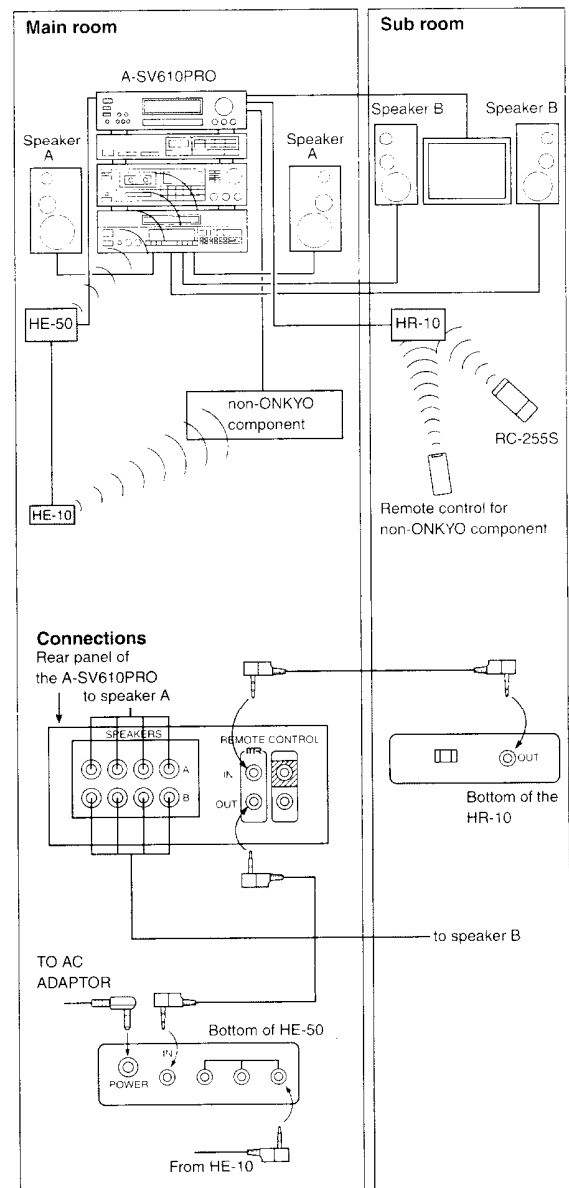

(C) To enable remote control operation when the A-SV610PRO is mounted in a rack which will not permit infra-red beams to pass, place the HR-10 somewhere outside the rack and set the HE-50(AC) in a position which will permit remote control operation of the A-SV610PRO. The HE-50(AC) is not necessary when utilizing the ONKYO set with the **RI** mark. Please connect the HR-10 and A-SV610PRO. (see Fig.3)

Fig. 3

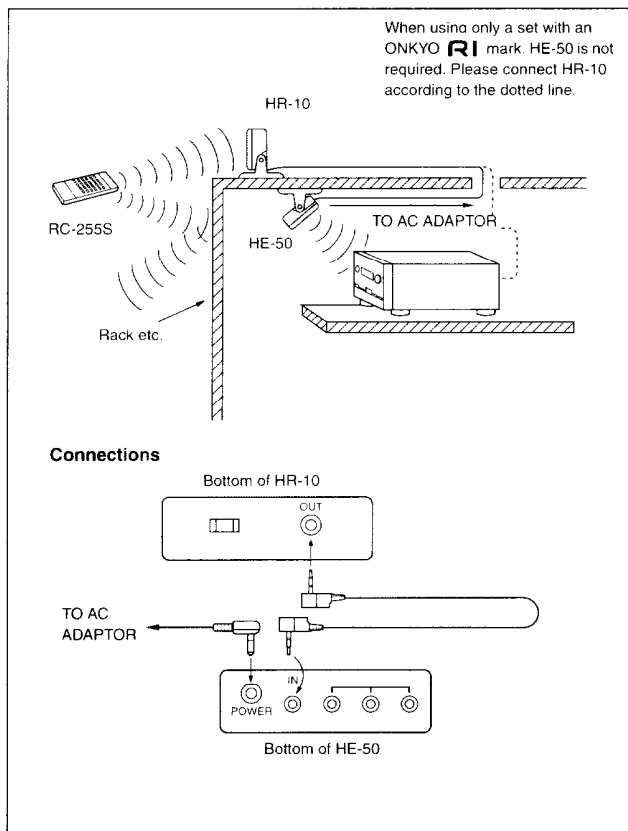

NOTES:

- Always unplung the AC power cords for the A-SV610PRO and HE-50(AC) when connecting the **MR**.
- Insert the **MR** mini-plug into the GREEN TERMINAL on the rearpanel of the A-SV610PRO.

Remote sensor and emitter (like the HR-10 and HE-50(AC)) should be connected with low capacitance shielded two coaxial cable with mini-plug 1/8" (3.5 mm diameter) connectors. Maximum cable length is determined by the characteristics of the particular cables used but approximately 164' (50 m) lengths are generally practical. Ready made cable complete with mini-plug connectors are available in the following lengths: 6-1/2' (2m) (HW-2), 98-7/16' (30m) (HW-30), and 164' (50m) (HW-50). (ONKYO cables may not be sold in some regions.) Refer to the instruction manual which comes with the HR-10 when making these connections. Use low impedance cables to connect the A-SV610PRO in the main room and a set of loudspeakers in another room.

Operation

Make sure that recording is not being carried out before setting the A-SV610PRO.

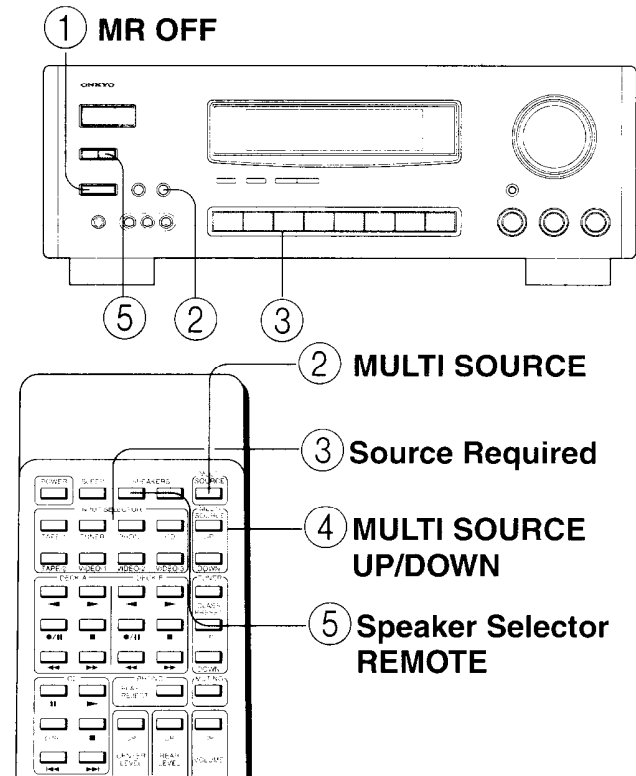

- ① Turn the **MR OFF** button OFF (**MR** indicator is turned off.)
- ② Press the **MULTI SOURCE** button.
 - **REC OUT** indicator will be turned off and the **MULTI SOURCE** indicator will flash for 8 seconds.
- ③ While this is flashing, use the input selector button to select the desired source.
 - **MULTI SOURCE** will light and the selected source will be marked with a red frame.
- ④ Adjust the level using the **MULTI SOURCE LEVEL UP/DOWN** buttons of the remote control transmitter.
 - **MULTI** and the level will be indicated on the display. It is recommended that the level be set lower in advance in the main room (-78 to -76dB).
- ⑤ Press the **REMOTE** button of the **SPEAKERS** to illuminate the **REMOTE** indicator.
 - Press the **MAIN** button to turn off the **MAIN** indicator if you are not listening the sound in the main room.

When changing the source, be sure to press the **MULTI SOURCE** button before pressing the input selector button. Pressing the input selector button without first pressing the **MULTI SOURCE** button will change the source in the main room.

NOTES:

- The surround mode will be turned OFF (Bypass) when **MULTI SOURCE** is used.
- The source indicated by the input selector will be output from the TAPE-1 and 2, and VIDEO-2 and 3 **REC OUT** terminals.
- Press the **REC OUT** button to change the **MULTI SOURCE** mode to the Surround mode or **REC OUT** selector modes.

■ **MR OFF button (MR OFF) and indicator**

Use this button for tape recording or for the surround sound modes. It is used to disable control of the ONKYO MR system via the remote control unit in another room. Pressing this button will illuminate the indicator, and control from another room will be disabled. Pressing the button again will turn the indicator off, and control from another room will be enabled.

NOTES:

- If the multi source is selected, the MR OFF will be automatically turned off.
- If the multi source is selected for REC OUT, and the SURROUND MODE button is selected, the MR ON will be automatically turned on.

- You can use the remote control transmitter supplied with this Amplifier to operate the source devices selected for the multi source if they are an ONKYO CD or cassette deck bearing the RI mark.
- There is a remote control unit RC-MR1H for the sub room, which is sold separately.
- Installation of the remote sensor unit HR-10 and the remote emitter unit HE-50(AC) is required to control non-ONKYO devices from another room (sub room). Operate the remote control unit included with the device by directing the control unit toward the HR-10 installed in another room (sub room).
- If a problem occurs, use the A-SV610PRO's front panel controls to verify that the problem is with the remote control transmitter. If there is no problem when operating the A-SV610PRO directly, check the batteries in the remote control transmitter first before assuming that there is a controller malfunction.

NOTES:

- The source may be changed or recording being done on the A-SV610PRO may be interrupted when operations are done in the another room. Press the MR Off button to disable the control from another room. (The MR indicator will be illuminated.)
- Some non-ONKYO remote control transmitters cannot be used.

Use of Surround mode

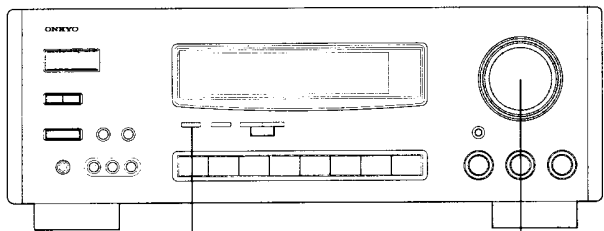

- ② SURROUND MODE
- ③ MASTER VOLUME

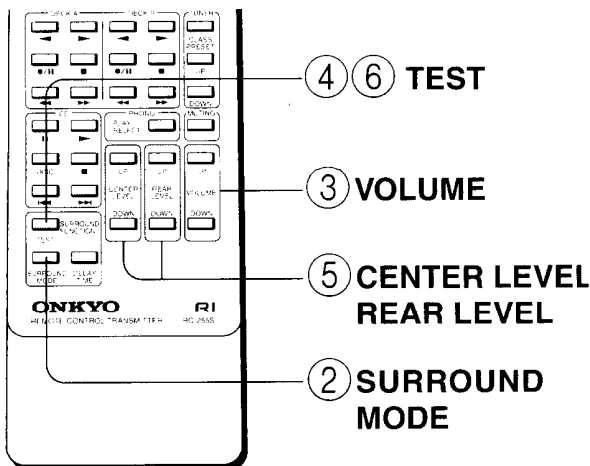

- ④ ⑥ TEST
- ③ VOLUME
- ⑤ CENTER LEVEL REAR LEVEL
- ② SURROUND MODE

■ **Adjusting the Dolby Pro Logic Surround Level**

All the operations can be controlled by the remote control transmitter. Functions No. ④ to ⑥ are operated only by the remote control transmitter.

- ① Select a source encoded with Dolby Surround.
- ② Use the SURROUND MODE button to select DOLBY PRO LOGIC mode.
- ③ Next, use the MASTER VOLUME to set the volume to the desired listening position.
- ④ Press the TEST button on the remote control transmitter.
 - "TEST" will appear on the display, and pink noise will be output for 1.5 seconds from each of the Left, Center, Right, and Rear (in that order) speakers. When the center mode is PHANTOM, this will be output in the following order: Left, Left + Right, Right, and Rear.
- ⑤ Use the remote control CENTER LEVEL UP/DOWN button to adjust the volume of the center speaker, and REAR LEVEL UP/DOWN button to adjust the volume of the rear speakers. Set the front, rear and center speakers to the same volume.
- ⑥ Press the TEST button to cancel the pink noise.

* Please see the next page for details regarding each button.

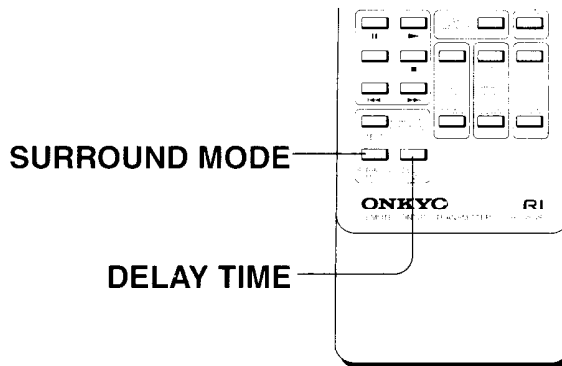
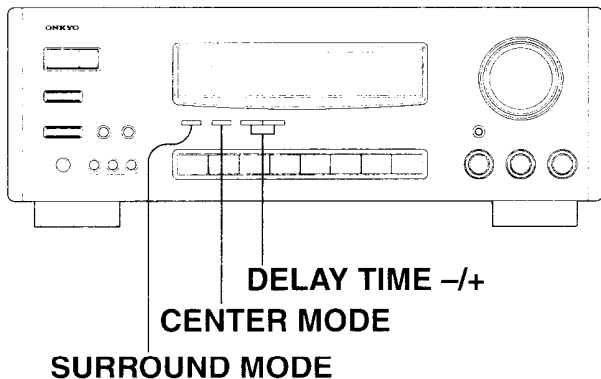

■ **Surround Mode button (SURROUND MODE) and indicators**

Use this button in conjunction with the sound source being reproduced. This will rotate one step at a time through the following pattern each time this button is pressed:

→ DOLBY PRO LOGIC → HALL → OFF (Bypass) →

DOLBY

PRO LOGIC : When the sound source features the DOLBY SURROUND trademark.

HALL : Create a concert-hall effect.

OFF

(Bypass) : When you are not using surround sound. When this is pressed, no sound is produced from the center and rear (surround) speakers.

These modes can be changed with the remote control transmitter by using the SURROUND MODE button.

- When you press and hold down the SURROUND MODE button, the name of each mode will be shown on the display for 2 seconds in turn.
- In the SURROUND MODE each selected mode along with the input selector source is automatically stored, and consequently recalled when that input selector source is selected.
- When the SURROUND MODE is set to HALL, the center speaker does not produce sounds.

■ **Center Mode button and indicator (CENTER MODE)**

Use this button setting according to the size of the center speaker for the Dolby Pro Logic Surround.

NORMAL : Use this setting when a small enclosure center speaker is utilized.

WIDE BAND : Use this setting when a speaker similar to the left and right stereo speakers is utilized.

PHANTOM : When a center speaker is not present.

- When you press and hold down the CENTER MODE button, the name of each mode will be shown on the display for 3 seconds in turn.

■ **Delay Time button (DELAY TIME -/+) and indicator**

You can change the delay time for the sound from the rear (surround) speakers. Pressing this button changes the delay time every 5 msec during a period of 15 to 30 msec in Dolby Pro Logic, and Hall surround.

- When you press and hold down the DELAY TIME button, "DELAY" and the delay time will be shown for 3 seconds on the display.

Dolby Surround delay time is specified at 20msec. It is recommended that initial Dolby Surround delay be set at 20msec, and adjustment to either 15 or 30 is possible via the control. By adjusting the delay time, and carefully adjusting Master Volume Level, Center Volume Level and Rear Volume Level, the apparent acoustic size of your listening room can be enlarged or reduced. Adjustable delay time allows you to tailor the acoustic size of your listening environment to match the sonic characteristics of the audio program. Use a longer delay for larger acoustic spaces, such as concert halls, cathedrals, etc. Use a shorter delay to simulate the size of a small club or cabaret. Respective delay times can be memorized for DOLBY PRO LOGIC and HALL. This operation can also be performed using the delay time button of the remote control transmitter.

NOTE:

If you are in surround mode and change the delay time, but the rear (surround) speakers are not connected, nothing will happen. However, even under these conditions, each time the delay time button and surround mode button are pressed, front speaker muting will occur and sound will disappear momentarily. This is not a malfunction.

Troubleshooting guide

NOTE:

If a problem occurs, first operate the unit using the front panel controls to confirm that it is not due to a malfunction (or worn out batteries) of the remote control transmitter.

Trouble	Cause	Remedy
No power.	<ul style="list-style-type: none"> ● Power cord is disconnected. ● There is external noise in the computer circuits of the A-SV610PRO. ● AC fuse blown. 	<ul style="list-style-type: none"> ● Connect power cord. ● Turn the power button off and then on again or remove the AC plug from the outlet and then plug it again. ● Contact your ONKYO service center.
Power but no sound.	<ul style="list-style-type: none"> ● Tape-2 monitor switch on. ● Audio muting switch on. ● Bad connections. ● Amplifier protection circuitry has been activated. 	<ul style="list-style-type: none"> ● Switch to off. ● Switch to off by remote control transmitter ● Check connections, speaker leads, etc. ● Contact your ONKYO service center.
Hum, low-frequency noise.	<ul style="list-style-type: none"> ● Poor or no input ground. ● Poor or no phono motor ground. ● The placement of the audio connection cable on the rear panel is not correct. 	<ul style="list-style-type: none"> ● Check outer conductor of input plugs. ● Check for proper ground connection. ● Adjust the placement of the cables to reduce hum.
Howling when the volume is turned up.	<ul style="list-style-type: none"> ● Turntable and speakers are too close together. 	<ul style="list-style-type: none"> ● Move them farther apart.
Rough or scratchy sound. High range is not clear.	<ul style="list-style-type: none"> ● Stylus of pick-up is worn. ● Stylus tip is dirty. ● Treble control too high. 	<ul style="list-style-type: none"> ● Replace. ● Clean. ● Turn treble control down.
The multiple room remote system does not operate.	<ul style="list-style-type: none"> ● Connection is wrong. ● The MR OFF button on the A-SV610PRO is engaged. (The MR OFF indicator will light.) 	<ul style="list-style-type: none"> ● Check the connection again. ● Press the MR OFF button. (The MR OFF indicator will be turned OFF.)
Front panel controls function but remote control transmitter does not.	<ul style="list-style-type: none"> ● No batteries in remote control transmitter. ● Batteries have worn out. 	<ul style="list-style-type: none"> ● Insert batteries. ● Replace batteries.

Also refer to the respective instruction manuals of the video disc player, video cassette recorder, TV monitor, etc., being used.

Specifications

AMPLIFIER SECTION

Power Output:

Stereo mode

Front L/R channels

125 watts per channel min. RMS. at 8 ohms, both channels driven, from 20 Hz to 20,000 Hz, with no more than 0.08% total harmonic distortion.

Dynamic power:

2 × 240 watts at 4 ohms

2 × 160 watts at 8 ohms

Surround mode and Multi source mode

Front L/R and center channels

70 watts per channel min. RMS. at 8 ohms, 1,000 Hz, with no more than 0.08% total harmonic distortion.

Rear or Remote channels

20 watts per channel min. RMS. at 8 ohms 1,000 Hz, with no more than 0.8% total harmonic distortion.

Total Harmonic Distortion: 0.08% at rated power (FRONT)

IM Distortion: 0.08% at rated power (FRONT)

Damping Factor: 60 at 8 ohms (FRONT)

Sensitivity and Impedance: Phono: 2.5 mV/50 kohms

CD/Tape Play: 150 mV/50 kohms

Tape Rec: 150 mV/2.2 kohms

Phono Overload: 120 mV RMS. at 1,000 Hz, 0.5% THD.

Frequency Response: 20 to 30,000 Hz, +/-1 dB

RIAA Deviation: 20 to 20,000 Hz, +/-0.8 dB

Tone Control: BASS: +/-10 dB at 100 Hz

TREBLE: +/-10 dB at 10,000 Hz

PHONO: 80 dB (IHF A, 5 mV input)

CD/TAPE: 100 dB (IHF A)

Muting: -∞ dB

VIDEO SECTION

Signal sensitivity and impedance

VIDEO input, output: 1 Vp-p, 75 ohms

GENERAL

Power Supply: USA & Canadian modes:

AC120 V, 60 Hz

U.K. & Australian models:

AC240V, 50Hz

Worldwide models

120 and 220 V switchable, 50/60 Hz

455 × 170 × 388 mm

17-15/16" × 6-11/16" × 15-1/4"

Dimensions (W × H × D):

Weight: 13.5 kg (29.8 lbs)

Specifications and external appearance are subject to change without notice because of product improvements.

This device employs a microcomputer to perform various functions and operations. If interference generated by an external power supply, radio waves, or other electrical source results in an accident which causes the specified operations and functions to operate abnormally. To perform a reset, please follow the procedure below.

1. Press and hold down the CD button, then press the POWER button.
2. "Test-" is displayed on the display for approximately 5 seconds.
3. While "Test-" is displayed, unplug the A-SV610PRO's power cord from its AC outlet, then "Test-" will disappear.
4. Preset memory and parameters stored in memory, such as surround are initialized and will return to the factory settings.

ONKYO CORPORATION

International Division: 2-1, Nisshin-cho, Neyagawa-shi, OSAKA 572, JAPAN
Tel: 0720-31-8133 Fax: 0720-34-1340

ONKYO U.S.A CORPORATION

200 Williams Drive, Ramsey, N.J. 07446, U.S.A.
Tel: 201-825-7950 Fax: 201-825-8150

NPN Transistor with Positive supply and +ve bias.

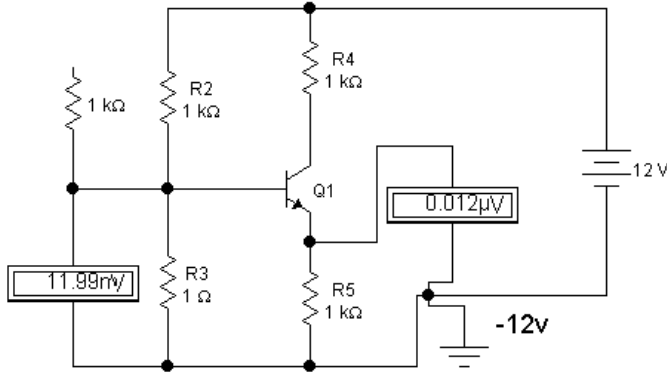

[[Rectangular box shows DVM]]

This typical circuit often seen in amplifier and power supply is a common approach to general application circuit design. This circuit is a normal configuration often used in amplifiers having an inverted output. The output of Q1 at its emitter shall have a loss up to 650mv depending on the transistor gain. The circuit shall have an output proportional of input, less switching loss. The bias voltage is dependant on R3 value, which also defines Q1 emitter output DC voltage. Other condition may exist depending on the value of R4 and R5.

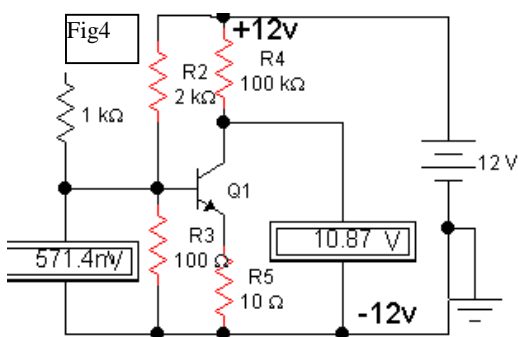
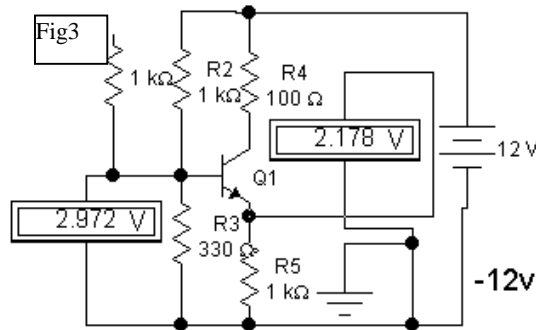
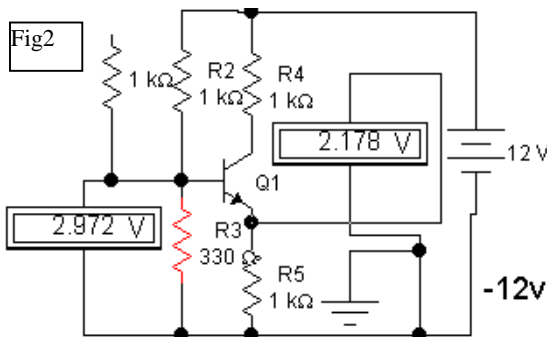

Unlike Fig 1, 2, and 3 fig 4 shows non-inverting output whose collector voltage can be switching opposite of the vb for Q1. The higher the vb at Q1 the lower the collector voltage will be. That is because more biasing will cause Q1 to conduct more as the current flow through R4 is nominal compared the current to be drawn through R5.

PNP transistor used with Positive Power supply to Emitter and +ve biased.

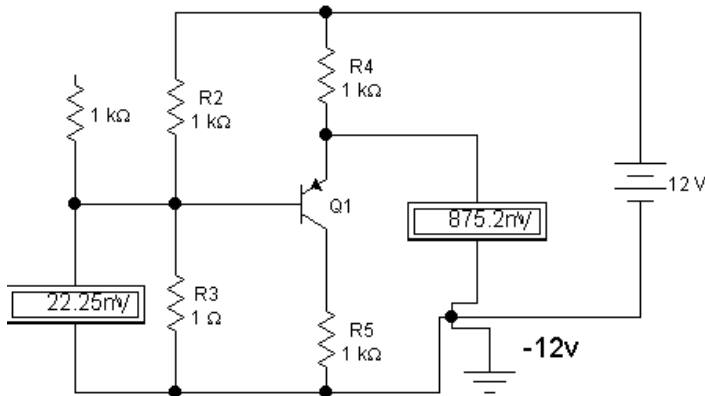

[[Rectangular box shows DVM]]

In this kind of configuration the transistor is biased by Positive voltage. Do to the characteristic of the PNP transistor reaction to a Positive supply at the emitter, the collector voltage will retain above the 600mv minimum switching voltage. Even when the v_b (base bias voltage) reaches near 0vdc, the lowest the collector voltage will get is 650mv. Such configuration of a transistor is good where a circuit is expected to operate at high frequency and need not idle below the switching voltage. It also provides none inverting output. The transistor output is dependant of v_b value, which can be trimmed by the resistor R3.

Such circuit is often used in video and like high frequency buffer circuit. It can also be used as sensory circuit or low-level amplifier.

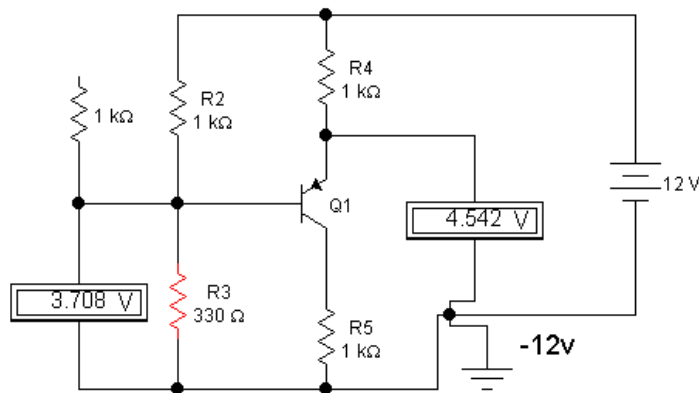

Technical Tip:

The procedure given above will clear all consumer saved setup. It is therefore important to document customer settings before performing reset.

MODEL#	FIRST	SECOND	COMPONENT	DISPLAY
TX-DS474/484	VIDEO-1	SPEAKER-A	RECEIVER	"CLEAR"
TX-DS555	CD	POWER	RECEIVER	"CLEAR"
TX-DS575/575X	VIDEO-1	SPEAKER-A	RECEIVER	"CLEAR"
TX-DS656	CD	POWER	RECEIVER	"CLEAR"
TX-DS676	VIDEO-1	SPEAKER-A	RECEIVER	"CLEAR"
TX-DS747	CD	POWER	RECEIVER	"CLEAR"
TX-DS777	VIDEO-1	SPEAKER-A	RECEIVER	"CLEAR"
TX-DS787	VIDEO-1	REC OUT	RECEIVER	"CLEAR"
TX-DS838	VIDEO-1	SPEAKER	RECEIVER	"CLEAR"
TX-DS939	CD	VIDEO-1	RECEIVER	"CLEAR"
TX-DS989	VIDEO-1	STAND-BY	RECEIVER	"CLEAR"
DR-90	VIDEO-1	SPEAKER-A	RECEIVER/DVD	"CLEAR"
LS-V900	SPEAKER-A/B	STAND-BY	RECEIVER/DVD	"CLEAR"
TX-SV210	CD	POWER	RECEIVER	"CLEAR"
TX-SV343/A-SV240	VIDEO-1	SPEAKER-A	RECEIVER	"CLEAR"
TX-SV373	VIDEO-1	SPEAKER-A	RECEIVER	"CLEAR"
TX-SV424/A-SV640	CD	POWER	RECEIVER	"CLEAR"
TX-SV434	CD	POWER	RECEIVER	"CLEAR"
TX-SV444/454	VIDEO-1	SPEAKER-A	RECEIVER	"CLEAR"
TX-SV525/535	VIDEO-1	POWER	RECEIVER	"CLEAR"
TX-SV545/A-SV610	CD	POWER	RECEIVER	"CLEAR"
A-SV620/	VIDEO-1	POWER	RECEIVER	"CLEAR"
TX-SV636	VIDEO-1	POWER	RECEIVER	"CLEAR"
TX-SV646/A-SV420	CD	POWER	RECEIVER	"CLEAR"
TX-SV727	VIDEO-1	POWER	RECEIVER	"CLEAR"
TX-SV828THX	VIDEO-1	POWER	RECEIVER	"CLEAR"
TX-SV919THX	CD	POWER	RECEIVER	"CLEAR"
TX-SV303PRO	MEMORY	POWER	RECEIVER	"TEST"
TX-SV313PRO	MEMORY	POWER	RECEIVER	"CLEAR"
TX-SV414PRO	MEMORY	POWER	RECEIVER	"CLEAR"
TX-SV515PRO	CD	POWER	RECEIVER	"CLEAR"
TX-SV515PROII	CD	POWER	RECEIVER	"CLEAR"
TX-SV717PRO	CD	POWER	RECEIVER	"CLEAR"
TX-SV909PRO	CD	POWER	RECEIVER	"CLEAR"
TX-8210	STANDBY	CD	RECEIVER	"CLEAR"
TX-8211	TAPE-1	SELECT CTR'L	RECEIVER	"CLEAR"
TX-8410PRO	VIDEO-1	POWER	RECEIVER	"CLEAR"
TX-8511	VIDEO-1	SPEAKER-A	RECEIVER	"CLEAR"

What is a PCB ?

Solution: PCB means "Printed Circuit Board"

In early 1960, most (if not all) electronic assemblies were assembled in a 'point-to-point' fashion. All of the components were strung through the air, literally supported by their wire leads. Big parts were bolted or soldered to a heavy steel chassis and the smaller parts were strung between them. These assemblies proved to be nightmarish to assemble & service. Then some genius came up with the idea of arranging all the components in a uniform fashion on a flat surface so it would be easier to locate and service individual parts.

Another branch idea to have developed was a way to actually 'print' the metal conductors on the board and the first printed wiring board (PWB) was created. Later, these became to be known as printed circuit boards (PCB)s. Today almost all electronic assemblies are made with a PCB. The PCB itself is usually a 1/16" thick or less of a fiberglass board (substrate) material. The circuitry on the PCB may be of copper, gold, silver conductors, called traces, which are directly laminated to the board and connect all the terminals of the electronic components. The board may have traces on just one side (a single sided PCB) or on both sides (doubled-sided PCB) or it may even have internal layers of traces (multi-layer PCB). Many PCBs are made from different substrates, such as acetate (flexible) or Alumina (ceramic). The formation or cutting of the traces is done after the copper is laminated to the substrate in a process known as etching.

ELECTRICAL / MECHANICAL APPLICATION FORMULAS

Power - AC Circuits, Power - DC Circuits, Mechanical, Fans & Blowers, Pump Motors

OHMS LAW

Volts (E) = Amps (I) x Ohms (R)
 Amps (I) = Volts (E) / Ohms (R)
 Ohms (R) = Volts (E) / Amps (I)

R=Ohms, E=Volts, I=Amperes

POWER - AC CIRCUITS

Eff. = Efficiency, PF = Power Factor, KW = Kilowatts, HP = Horsepower

Efficiency =	$\frac{746 \times \text{Output HP}}{\text{Input Watts}}$		3Ø KW =	$\frac{\text{Volts} \times \text{Amps} \times \text{PF} \times 1.732}{1000}$
3Ø Amps =	$\frac{746 \times \text{HP}}{1.732 \times \text{Eff.} \times \text{PF}}$		3Ø Eff. =	$\frac{746 \times \text{HP}}{1.732 \times \text{Volts} \times \text{Amps} \times \text{PF}}$
3Ø PF =	$\frac{\text{Input Watts}}{\text{Volts} \times \text{Amps} \times 1.732}$		1Ø KW =	$\frac{\text{Volts} \times \text{Amps} \times \text{PF}}{1000}$
1Ø Amps =	$\frac{746 \times \text{HP}}{\text{Volts} \times \text{Eff.} \times \text{PF}}$		1Ø Eff. =	$\frac{746 \times \text{HP}}{\text{Volts} \times \text{Amps} \times \text{PF}}$
1Ø PF =	$\frac{\text{Input Watts}}{\text{Volts} \times \text{Amps}}$		HP (3Ø) =	$\frac{\text{Volts} \times \text{Amps} \times 1.732 \times \text{Eff.} \times \text{PF}}{746}$
HP (1Ø) =	$\frac{\text{Volts} \times \text{Amps} \times \text{Eff.} \times \text{PF}}{746}$		1 KW = 1000 Watts	

POWER - DC CIRCUITS

Eff. = Efficiency, HP = Horsepower

Watts =	Volts x Amps		Amps =	$\frac{\text{Watts}}{\text{Volts}}$
HP =	$\frac{\text{Volts} \times \text{Amps} \times \text{Eff.}}{746}$			

MECHANICAL

Torque in lb. ft., RPM=Revolutions Per Minute, HP = Horsepower

Torque =	$\frac{\text{HP} \times 5250}{\text{RPM}}$ Result is lb.ft. Multiply by 12 for lb.in.		HP =	$\frac{\text{Torque} \times \text{RPM}}{5250}$
1 HP =	36 lb.in. @ 1750 RPM		1 HP =	3 lb. ft. @ 1750 RPM

FAN AND BLOWER MOTORS

CPM = Cubic Feet per Minute, Pressure in lb. / sq. ft., Eff. = Efficiency

HP =	$\frac{\text{CFM} \times \text{Pressure}}{33000 \times \text{Eff.}}$			
------	--	--	--	--

NPN Transistor working with Negative supply and Negative bias.

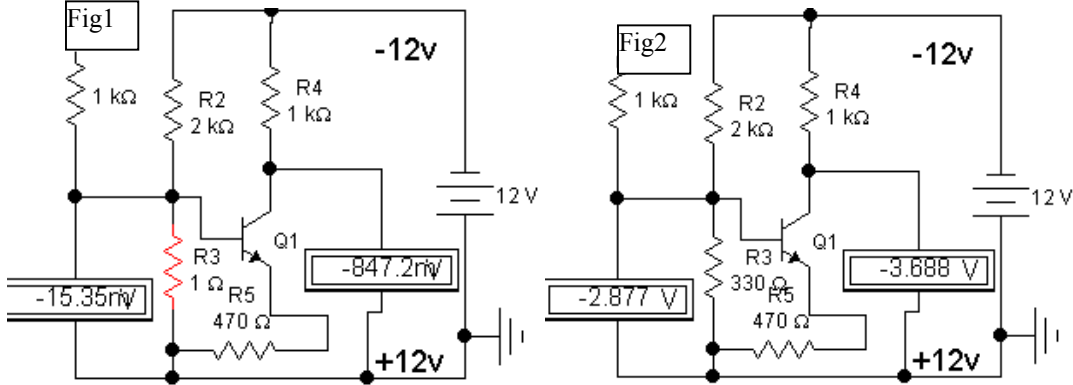

[[Rectangular box shows DVM]]

NPN transistor response to a negative supply and negative bias is not different than PNP with Positive bias and Positive supply. Inherently NPN transistor will fully turn off with negative supply at its collector and biased with any voltage $\leq 580\text{mv}$ positive. Both the inverted and non-inverted outputs of the transistor will stop at the lowest 600mv DC level even when the v_b is near zero. Even though NPN transistor may not be configured as such often times it is still possible to find a circuit design employing such technique for the purpose of switching and sensory (compare) device buffer.

Fig1 and Fig2 are just to show some of the results that may be found when the value of R3 is changed. However Q1 can be made to output $\geq 0\text{vdc}$ by biasing it with a positive voltage.

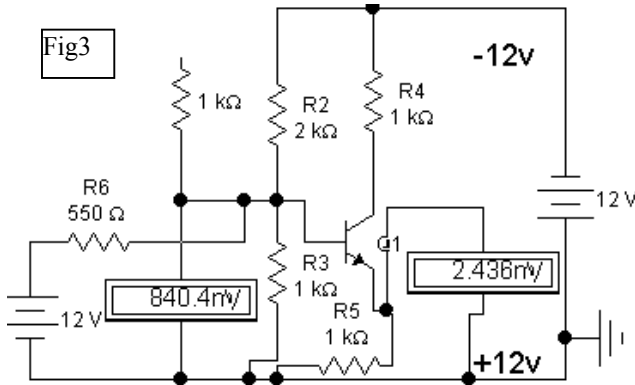

In such instance the value of R6 becomes a critical factor on how Q1 shall function. Q1 can be said to have turned off from conducting negative voltage when biased by positive voltage except now it is responding to the base voltage by allowing current to flow through to the Emitter as well as Collector. One can assume that the transistor has gone in to a breakdown mode at this point. As long as the current is low this may not be considered critical operating circuit.

Techniques for Replacing Surface Mount (SMD) IC's

Every technician has had to replace a surface mount device (SMD) IC at one time or another. How do you successfully remove and replace a surface mount IC? By successful I mean removing the defective IC without damaging the delicate traces on the PC board and aligning and soldering the replacement IC in place. Here are a few techniques you can use to remove and replace a surface mount IC.

IC Removal

Desoldering Braid: Desoldering braid is a specially treated fine copper braid which draws molten solder up into the braid where it solidifies. Desoldering braid is usually sold on a small dispenser reel. The best way to use desoldering braid is to press the tip of a hot iron onto a short length of braid that is placed over the joint to be de-soldered.



The iron will subsequently melt the solder, which will be drawn up into the braid. If the desoldering braid is not drawing the solder but just seems to push it around the board add a small amount of solder flux to the braid and try it again. After most of the solder has been wicked use a dental pick or similar object and lift the IC pins while heating them with a hot soldering iron.

Razor Knife Technique: Using a **sharp** razor knife, align the blade close to the body of the IC and on the top of the row of pins. Applying a constant downward force cut the pins away from the body of the IC. You will hear a distinct clicking sound as you sever the pins.



Work your way down the row. Repeat this process for each row of pins until the body of the IC is free from any pins and can be lifted away from the board. By cutting and removing the body of the IC you are removing the “heat sink” that draws the heat from the IC pins when you try to remove the IC with desoldering braid alone. Next, use desoldering braid and a hot soldering iron to remove the remaining IC pins from the board. This method allows you to remove the IC quickly and without damaging the PC

board's copper traces. One word of caution, this technique takes some practice. You are using a sharp razor knife that WILL cut the boards traces if you use too much force while cutting through the IC's pins. Check the board before you solder the new IC in place. It is highly recommended that you *practice* this method on some scrap boards before trying it on a customers unit.

Wire removal method: Apply flux to the IC pins. Use desolder braid to remove as much solder as possible from each pin. Thread fine stainless steel or enamel coated wire under one row of pins. Secure one end of the wire on a nearby component (i.e. a large Electrolytic capacitor). Starting at the loose end, heat each pin and pull wire simultaneously. Pull the wire as close to the PCB as practical.

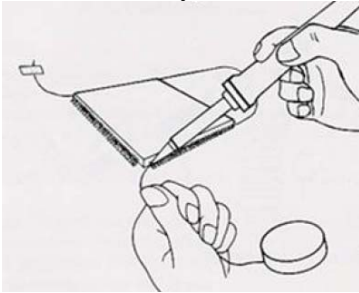

As the solder between the pin and pad melts, the wire will pop out and leave the pin standing free of the pad. Repeat these steps for the other sides.

Hot air desoldering tool: There are several types of hot air desoldering systems. Desoldering tools range from the inexpensive portable “pyroopen” type that uses butane fuel and a catalytic burner to produce heat, to the sophisticated temperature controlled, auto-timed, variable suction, multi-nozzle hot air systems that can cost you hundreds or thousands of dollars.



If you are on a tight budget, a handy device to get the job done is the “pyroopen” or hot air torch. These hot air, butane fueled, catalytic burner devices can be purchased for under \$100.00. To use this type of hot air device you have to ignite the torch, and adjust the temperature. After it warms up place the nozzle tip about $\frac{3}{4}$ to 1 inch above the legs of the IC you wish to remove. Move the nozzle tip around the IC to uniformly heat the IC's legs until the solder liquefies. Once the solder has liquefied use a dental pick or similar device to lift the IC away from the board. As with other methods described here, practice removing IC's from a scrap board to hone your technique before you work on a customers unit.

IC Replacement

Soldering Techniques: OK, now that you removed the IC from the board, how do you solder the replacement IC on the board? Here are some basic techniques for soldering a replacement IC to the PC board. First, make sure the lands are CLEAN. That means removing all solder and flux left behind during the IC extraction process. Next, check the board to make sure the traces are not broken, cut or lifted. Place the new IC on the board and position it so all of the pins are properly aligned (IC pin 1 to board land #1, etc.) on the board. Once you have verified the traces are properly aligned, secure the new IC to the board. One method to secure the IC is to use a piece of clear adhesive tape to hold the IC to the board. Another method would be to apply pressure to the top of the IC using a probe or tweezer to keep it in place while soldering it.



Secure the IC and solder.

Once the IC is secured, solder the corners of the IC first to hold the chip in place. If you are using tape to secure the IC you can remove it once you have the corners soldered in place. Add a bit of solder flux (liquid or paste) to the unsoldered pins and then solder the remaining pins. Adding the flux allows the molten solder to adhere to the lands and IC pins which will reduce the number of unreliable solder connections.

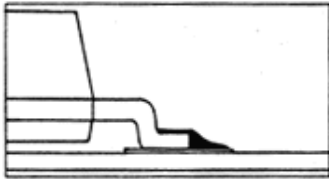

A good solder connection.

Next, check your work! Remove solder bridges between the IC's pins with desoldering braid and reflow any doubtful solder connections. You may want to use a magnifying glass to help check your work.

Here are 10 basic steps to successfully soldering an IC (or any component):

1. Make sure all parts are clean and free from dirt and grease.
2. Secure the IC or component firmly to the board.
3. "Tin" the iron tip with a small amount of solder.
4. Clean the tip of the hot soldering iron on a damp sponge.
5. You can add a tiny amount of fresh solder to the clean tip.
6. Heat all parts of the joint with the iron for a second or so.
7. Continue heating and apply sufficient rosin core solder to form a smooth joint.
8. It only takes two or three seconds at most, to solder the average p c board joint.
9. Do not move parts until the solder has cooled.
10. Check you work for solder bridges and cold solder connections.

PNP Transistor behavior with Negative supply and bias.

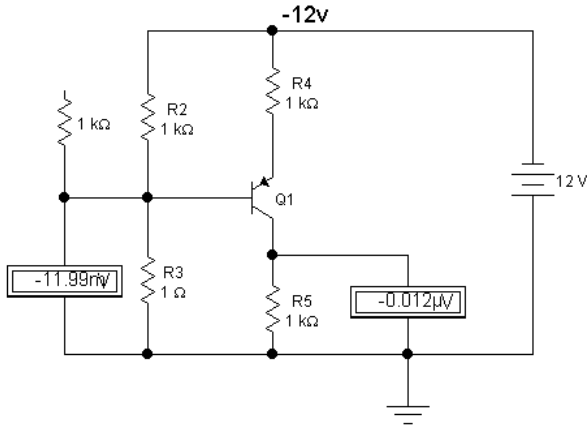

[[Rectangular box shows DVM]]

Positive as ground reference; Q1 is biased by the supply voltage -ve, variable depending on the value of R3. In such configuration Q1 can be turned off completely. The output of Q1 collector is equal to the v_b less the 600mv loss within the transistor. Output should be expected to invert. Such configuration may be used as Voltage dependant switching and control such as amplifier bias stage, ALC, and sensory circuits.

The ability to vary the output of Q1 collector form zero to its maximum given supply voltage less the component switching loss, makes the circuit widely usable in the audio, video and general power supply manufacturing industry. The configuration is normal for PNP transistor with a negative voltage supply at its Emitter.

