

ONKYO® SERVICE MANUAL

COMPACT DISC CHANGER

MODEL C-707CHX

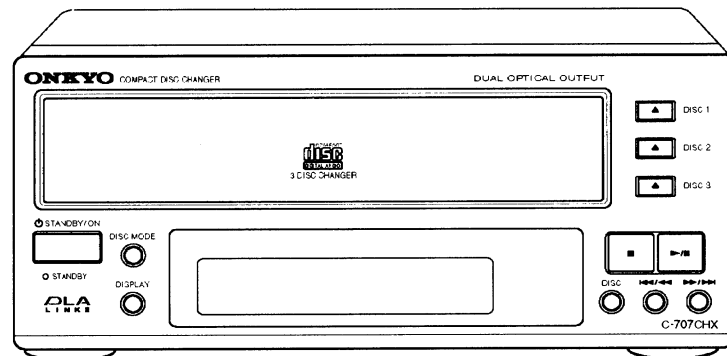

Black Model

BUD	120V AC/60Hz
-----	--------------

SAFETY-RELATED COMPONENT WARNING!!

COMPONENTS IDENTIFIED BY MARK  ON THE SCHEMATIC DIAGRAM AND IN THE PARTS LIST ARE CRITICAL FOR RISK OF FIRE AND ELECTRIC SHOCK. REPLACE THESE COMPONENTS WITH ONKYO PARTS WHOSE PART NUMBER APPEAR AS SHOWN IN THIS MANUAL.

MAKE LEAKAGE-CURRENT OR RESISTANCE MEASUREMENTS TO DETERMINE THAT EXPOSED PARTS ARE ACCEPTABLY INSULATED FROM THE SUPPLY CIRCUIT BEFORE RETURNING THE APPLIANCE TO THE CUSTOMER.

TABLE OF CONTENTS

Specifications/Service procedure.....	2
Caution on replacement of optical pickup.....	3
Block diagram.....	4
Chassis-Exploded view and parts list.....	5
IC Block diagram and descriptions.....	6-13
Microprocessor terminal descriptions.....	14
Front panel/Display/Remote controller view.....	15
How to remove CD Mechanism assembly from unit.....	16-19
CD Mechanism exploded view and parts list.....	20-22
Printed circuit board view.....	23-24
Schematic diagram.....	25-26
Printed circuit board parts list.....	27
Adjustment procedures.....	28
Packing view and parts list.....	29

ONKYO®
AUDIO COMPONENTS

SPECIFICATIONS

Signal readout system	Optical non-contact
D/A converter	1 bit D/A converter
Frequency response	5 Hz - 20 kHz
Total harmonic distortion	0.005% (at 1 kHz)
Channel separation	85 dB
Dynamic range	96 dB
Signal to noise ratio	90 dB
Wow and Flutter	Below threshold of measurability
Output level	2 volts r.m.s.
Power consumption	14 watts
Power supply rating	AC 120V, 60 Hz
Dimensions (W x H x D)	205 x 91 x 334 mm
Weight	3.0 kg

Specifications and external appearance are subject to change without notice because of product improvements.

SERVICE PROCEDURE

Safety-check out (Only U.S.A. model)

After correcting the original service problem perform the following safety check before releasing the set to the customer.

Connect the insulating-resistance tester between the plug of

power supply cord and terminal GND on the back panel.

Specifications: More than 10Mohm at 500V.

Perform a reset

This device employs a microprocessor to perform various functions and operations. If interference generated by an external power supply, radio waves, or other electrical source results in an accident which causes the specified operations and functions to operate abnormally.

To perform a reset, please follow the procedure below.

1. It is confirmed for the tray of CD to close.
2. "STAND-BY/ON" is pushed while pushing the STOP key from the state with the power supply on.
3. It is confirmed that the display of the FL tube disappears, and Stand-by LED lights.
4. The AC code is pulled out.
5. Preset memory and parameters stores in memory, such as surround are initialized and will return to the factory settings.

PROTECTION OF EYES FROM LASER BEAM DURING SERVICING

This set employs a laser. Therefore, be sure to follow carefully the instructions below when servicing.

WARNING!!

WHEN SERVICING, DO NOT APPROACH THE LASER EXIT WITH THE EYE TOO CLOSELY. IN CASE IT IS NECESSARY TO CONFIRM LASER BEAM EMISSION, BE SURE TO OBSERVE FROM A DISTANCE OF MORE THAN 30cm FROM THE SURFACE OF THE OBJECTIVE LENS ON THE OPTICAL PICK-UP BLOCK.

Laser Diode Properties

Material: GaAS/GaALAs

Wavelength: 780nm

Emission Duration: continuous

Laser output: max. 0.5mW*

*This output is the value measured at a distance about 1.8mm from the objective lens surface on the Optical Pick-up Block.

LASER WARNING LABEL

The label shown below are affixed.

1. Warning label

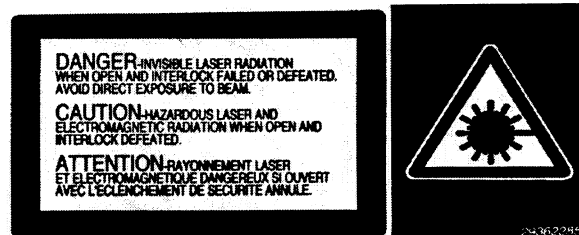
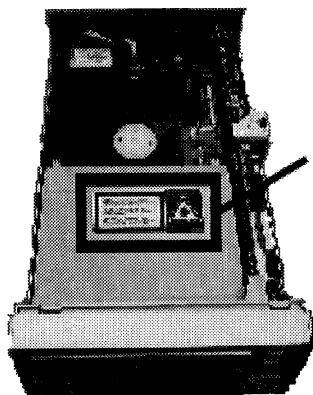

CAUTION ON REPLACEMENT OF OPTICAL PICKUP

The laser diode in the optical pickup block is so sensitive to static electricity, surge current and etc., that the components are liable to be broken down or its reliability remarkably deteriorated.

During repair, carefully take the following precautions. (The following precautions are included in the service parts.)

PRECAUTIONS

1. Ground for the work-desk.

Place a conductive sheet such as a sheet of copper (with impedance lower than 10Mohm) on the work-desk and place the set on the conductive sheet so that the chassis.

2. Grounding for the test equipments and tools.

Test equipments and toolings should be grounded in order that their ground level is the same the ground of the power source.

3. Grounding for the human body.

Be sure to put on a wrist-strap for grounding whose other end is grounded.

Be particularly careful when the workers wear synthetic fiber clothes, or air is dry.

4. Select a soldering iron that permits no leakage and have the tip of the iron well-grounded.

5. Do not check the laser diode terminals with the probe of a circuit tester or oscilloscope.

Care should be taken with the optical pickup.

The optical pickup is sensitive to static electricity, surge currents, and other high electrical noise, and because there is the possibility of damage to performance, in the handling of the pickup, the utmost care must be taken, particularly with regard to static electricity.

1. When checking the laser terminal, avoid making connections using the probes of a tester or oscilloscope, or an ordinary power supply.
2. When replacing the optical pickup, first short the LD terminals and remove the connector. Also, when attaching the new optical pickup, after attaching the connector, unsolder the LD terminals.

Pc board of optical pickup

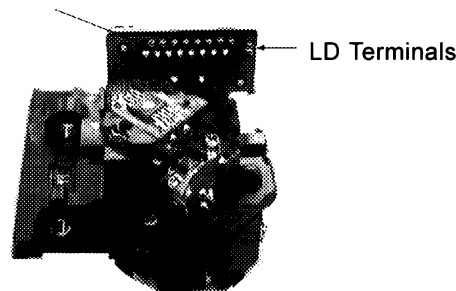

BLOCK DIAGRAM

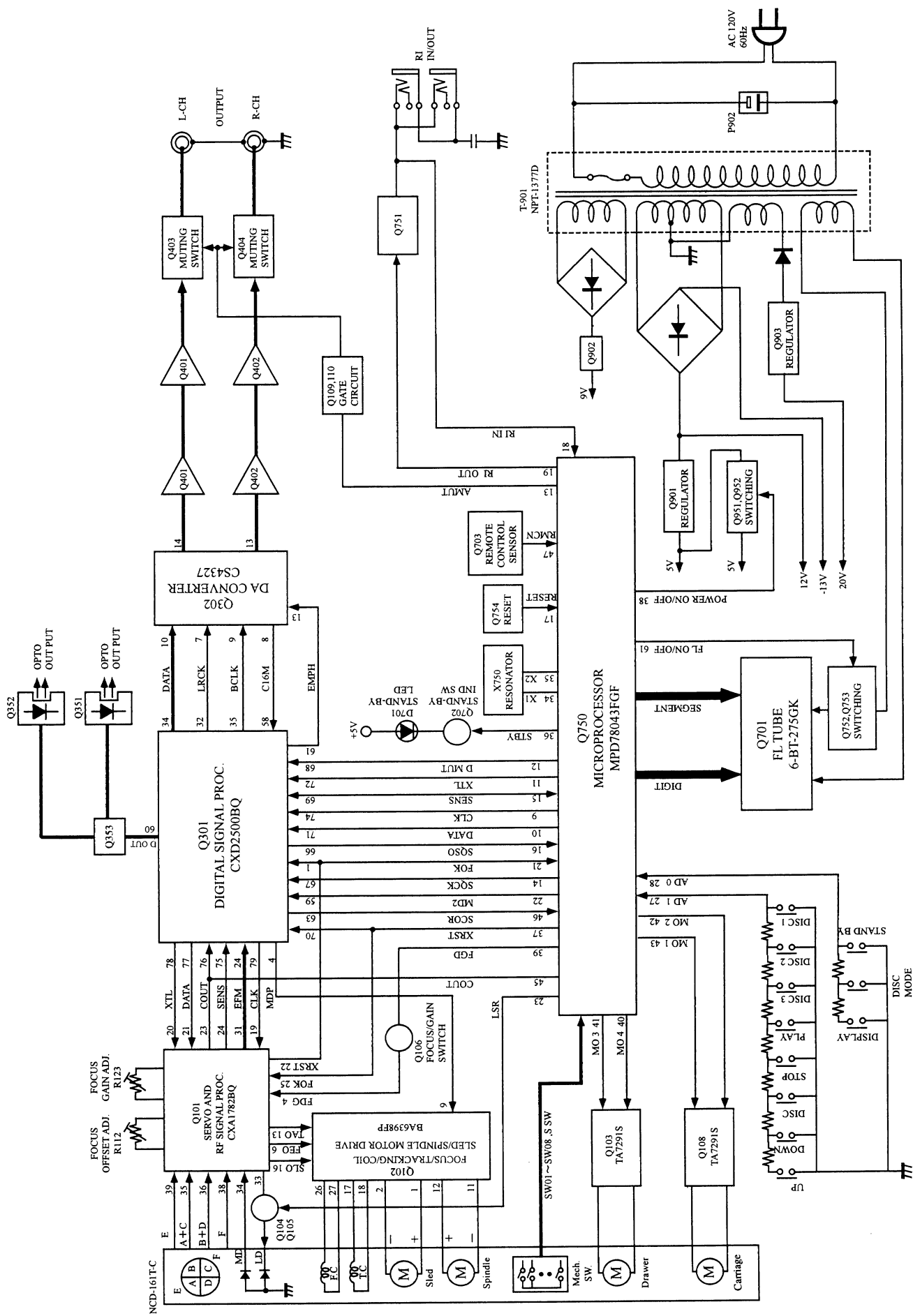

CHASSIS-EXPLODED VIEW

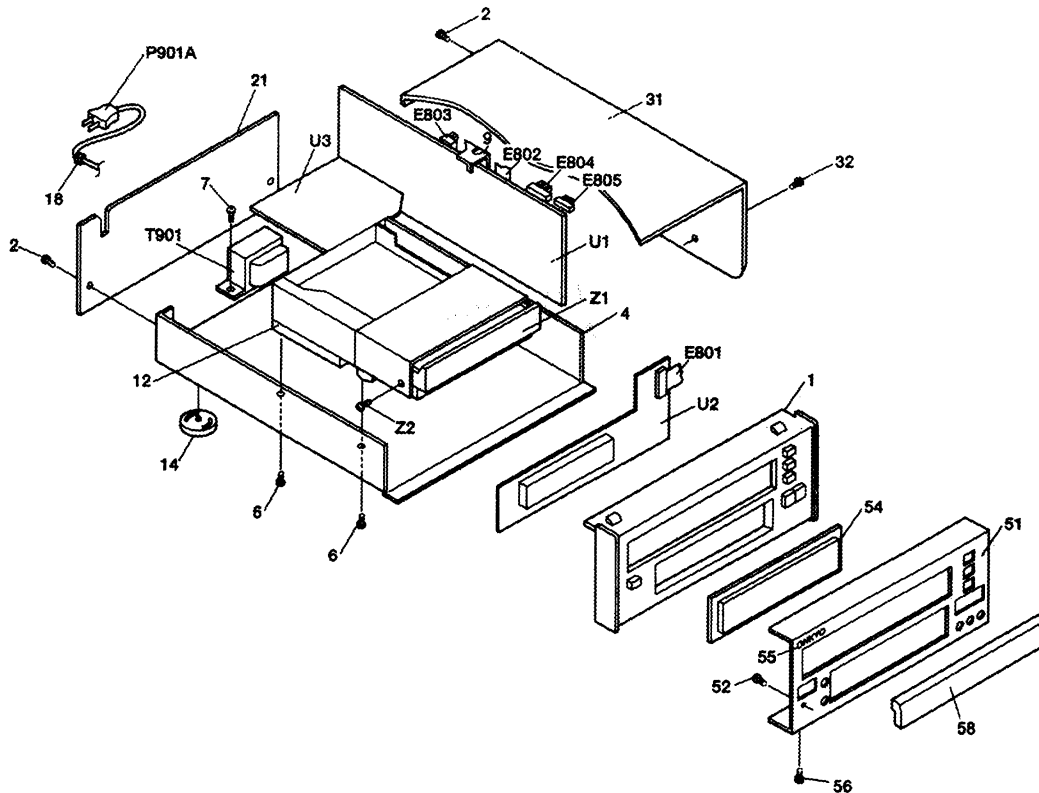

PARTS LIST

REF. NO.	PART NO.	DESCRIPTION	REF. NO.	PART NO.	DESCRIPTION
1	27111169	Front Bracket	E801	2045301512	NCFC5-301512, Flat cable
2	838130088	3TTB+8B, Screw	E802	2045161512	NCFC5-161512, Flat cable
4	27100360	Chassis	E803	2002391225	NSAS-12P0656, Socket ass'y
6	831430088	3TTW+8B(BC), Screw	E804	2001291815	NSAS-18P0657, Socket ass'y
7	830440089	4TTC+8C(BC), Screw	E805	2001290815	NSAS-8P0658, Socket ass'y
9	27130816A	Bracket (PC)	E806	260208	SK Binder
12	27191046	Holder (M)	P901A	△ 253279HDK	AS-UC-2#18, Power supply cord
14	27175323	Leg Ass'y	T901	△ 2301428	NPT-1377D, Power transformer
18	△ 27300750	Bushing (S-RELIEF #2271)	Z1	24800040	NCD-161T-C, CD Mechanism ass'y
11	27122701	Rear panel	U1	1H438544-2	NAAR-6244 Main circuit PC board ass'y
31	28184783	Top cover	U2	1H438545-2	NADIS-6245-2 Display circuit PC board ass'y
32	838430088	3TTB+8B(BC), Screw	U3	1H438546-2	NAPS-6246-2 Power supply circuit PC board ass'y
51	27212222	Front panel			
52	28198864	Facet			
54	28191891	Clear plate			
55	28135279	Badge			
58	28148448	Door (CD)			
59	27262600	Plate (S)			

△ : Critical safety part.

Microprocessor terminal descriptions

Pin No.	Symbol	I/O	Description
1	NCO		Not used.(Open)
2 ~ 7	002~007	O	FL tube grid output. (at active "H")
8	VDD	I	Power supply terminal. +5V.
9	CLK	O	Command transfer clock output terminal to signal processor IC CXD-2500BQ #74CLK.
10	DATA	O	Command data output terminal to signal processor IC CXD-2500BQ #71DATA.
11	XLT	O	Command latch output terminal to signal processor IC CXD-2500BQ #72XLT.
12	DMUT	O	Digital muting output terminal to signal processor IC CXD-2500BQ #68DMUT. (at active "H")
13	AMUT	O	Analog muting output terminal. (at active "H")
14	SQCK	O	Sub cord transfer clock output terminal to signal processor IC CXD-2500BQ #67SQCK.
15	SENS	I	Sens signal input terminal from processor IC CXD-2500BQ #69SENS.
16	SQSO	I	Sub code input terminal from signal processor IC CXD-2500BQ #66SQSO.
17	RESET	I	Reset signal input terminal. (at active "L")
18	RI.IN	I	System signal input terminal. (at active "H")
19	RI.OUT	O	System signal output terminal. (at active "L")
20	AVSS	I	Grand terminal.
21	FOK	I	Focus OK input terminal for IC CXA-1728BQ #25FOK. (at active "H")
22	MD2	O	Control signal for digital output terminal to Processor IC CXD-2500BQ #59MD2. (at output-ON "H")
23	LSR	O	Control for laser ON/OFF output terminal. (at active "L")
24 ~ 26	NC1~NC3		Not used.
27,28	AD1,AD2	I	Key input terminal.
29	AVDD	I	A/D converter power supply terminal for key input. +5V.
30	AVREF	I	A/D converter reference voltage input terminal for key input. +5V.
31	XT1	I	Sub clock oscillator circuit input terminal.(connected to GND)
32	XT2		Not used.
33	VSS1	I	GND terminal.
34	X1		Resonator connection terminal for main system clock
35	X2		Connect the ceramic resonator 4.0MHz.
36	STANDBY	O	Stand-by LED drive output terminal. (at active "H")
37	CDRESET	O	Reset output for servo and signal processor IC terminal. (at active "L")
38	POWER	O	Power (+5V) control output terminal. (at active "H")
39	FGD	O	Focus gain down control output terminal. (Not used)
40 ~ 43	M04 ~ M01	O	CD mechanism motor output terminal.
44	SSTOP	I	Pick-up inner side sensor of mechanism switch input terminal. (at inner side "L")
45	COUT	I	Count of track number input terminal for CXA-1782BQ #23C.OUT.
46	SCOR	I	Output of subcode sync. input terminal for Processor IC CXD-2500BQ #63SCOR.
47	RMCN	I	Remote control signal input terminal. (at active "L")
48	IC		Connect to GND.
49 ~ 51	NC4 ~ NC6		Not used.
52	VDD2	I	Power supply terminal. +5V.
53 ~ 60	SW1 ~ SW8	I	CD mechanism switch input terminal.
61	FLOFF	O	Filament control output terminal.
62 ~ 70	062 ~ 070	O	Segment output terminal.
71	-VLOAD	I	Power supply terminal of FL tube -V.
72 ~ 77	072 ~ 077	O	Segment output terminal.
78 ~ 80	NC7 ~ NC9		Not used.

Front panel

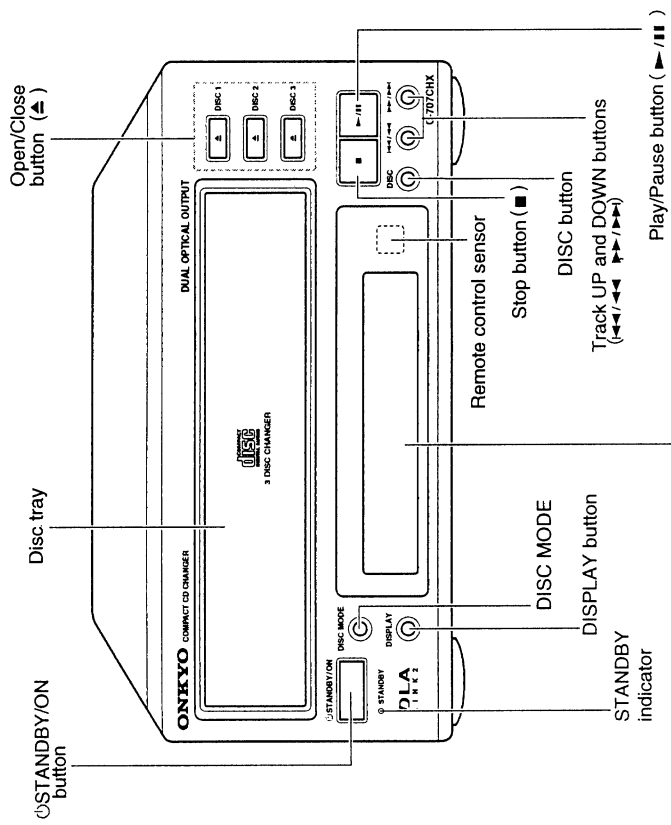

Display

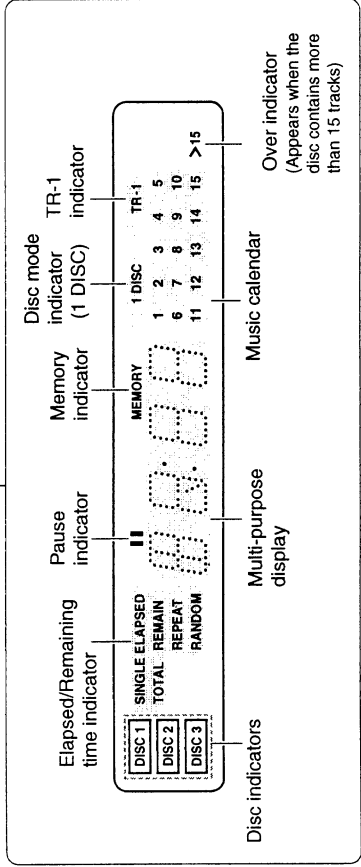

Remote controller

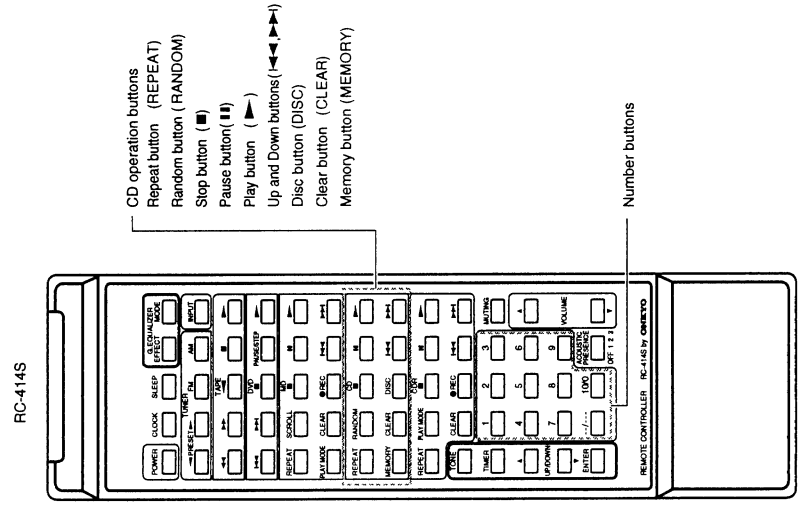
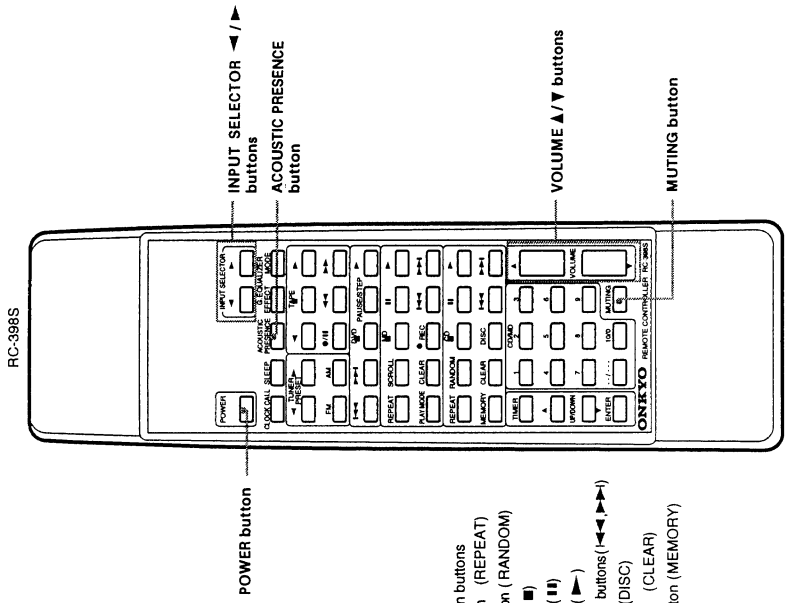

Remote controller included with the A-905X(RC-398S) and R805X(RC-414S). To operate the included remote controller, make the appropriate connection to the **RI** remote connection.

A. How to remove CD Mechanism Assembly from unit:

Turn the unit upside-down and short one point with solder from the Chassis hole. This point is marked with "S" on CD Mechanism PC Board. This is necessary to prevent Opt-pickup electrostatic damage. (See Fig. 1.)

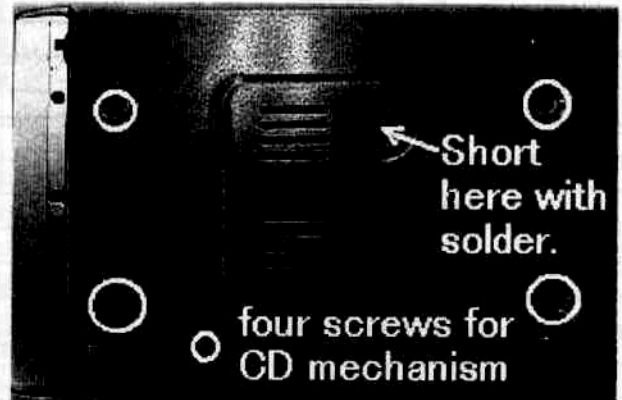

Fig. 1

B. How to dismantle CD Changer Mechanism:

When replacing the optical pickup, first short the pattern on the CD Pick Up PC Board. (See Fig.1) Short the pattern for electrostatic protection on the CD Pick Up PC board before removing the flexible flat cable from it. After soldering, remove the flexible flat cable from the CD Pick Up PC Board.

When replacing mechanism parts, do as follows:

First short the pattern with "S" for electrostatic protection on U-shaped CD mechanism PC Board. (Short from the bottom chassis hole.) (See Fig.1, Fig.2)

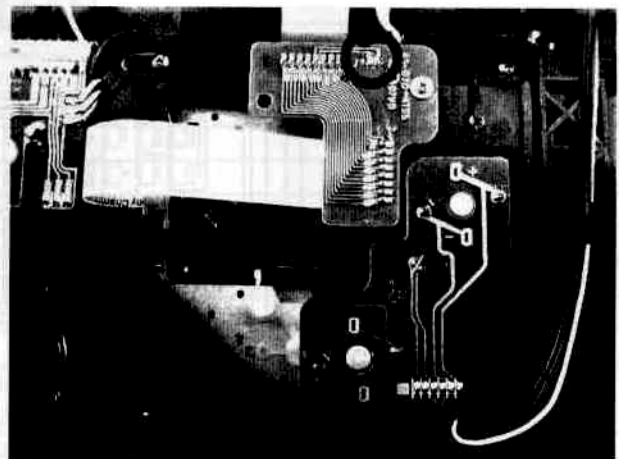

Fig.2

C. How to remove the Drawer block:

1. This is the normal way. (See pages 27 and 28 in the Service Manual.)

- 1) Remove 6 SCREWS(115) from COVER(23).
- 2) Turn PULLEY B(32) anti-clockwise and pull DRAWER(2) block. The DRAWER block is easily pulled out. (See Fig.3)



Fig.3

3) After pulling out DRAWER block until around its half, divide CHASSIS(1) block hooks which fixing DRAWER block from the two points of left side then the right two with a minus(-) shaped driver or fingers.(See Fig. 4)(Because gears gang together inside at the right side.) With holding DRAWER block upward, pull out FLEXIBLE FLAT CABLE, FFC(75) from ONNECTOR(73) on connector PC BOARD(70), straight to the insertion direction.(See Fig. 5)



Fig.4

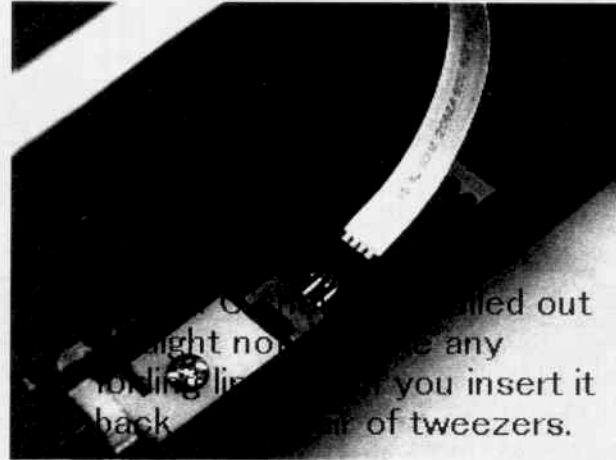

Fig.5

Note :

Take care not to make folding lines or scratches on the cable.
Lines or scratches may cause broken wire after long use.

2. This is the way when Carriages are jammed inside.

- 1) Remove 6 SCREWS(115) from COVER(23).
- 2) Divide CHSSIS(1) block hooks which fixing DRAWER(2) block from the two points of left side then the right two with a minus(-) shaped driver or with fingers as like as below..(Because gears gang together inside at the right side.) With holding DRAWER block upward, pull out FFC(75) from CONNECTOR(73) on connector PC BOARD(70), straight to the insertion direction. (See Fig. 4, Fig. 5)

Note :

Take care not to make folding lines or scratches on the cable.
Lines or scratches may cause broken wire after long use.

D. How to remove CARRIAGES?

How to remove CARRIAGES 10, 20 or 30(Carriage number changes with chances of Disk stopping) from CHASSIS(1).

- 1) Slide SLIDER 2(36) block inside and make the pin locked at inner-most of SLIDER 2 with ARM STOPPER B(38).
- 2) Then, slide SLIDER 2(36) outside.
- 3) By sliding SLIDER 2, ARM(44) moves up and it is locked.
- 4) Then CARRIAGES are unlocked and are easily removed outside.

Note :

How to distinguish CARRIAGES 10, 20 or 30.(See Fig.6)

Turn CARRIAGE upside-down and you can see two posts for CARRIAGE number detection.

CARRIAGE 10 has one post at inside.
CARRIAGE 20 has one post at outside.
CARRIAGE 30 has two posts at the both sides.

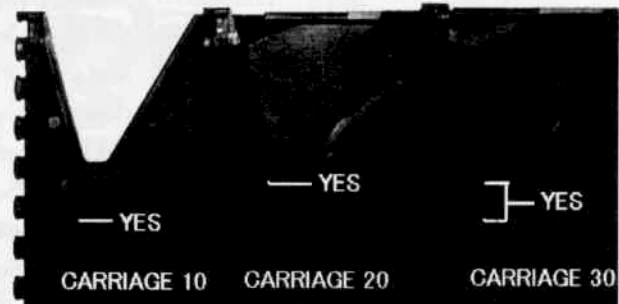

Fig.6

How to remove CARRIAGES from DRAWER block

- 1) Turn GEAR IDLER 2(17) anti-clockwise. (See Fig. 7)
- 2) By turning GEAR IDLER 2, the uppermost CARRIAGE slides out.
- 3) Hold the CARRIAGE at its center and bring it up. Then you can take it out.
- 4) Then, turn GEAR IDLER 2(17) anti-clockwise and take out the second CARRIAGE.
- 5) Take out the bottom CARRIAGE with the same way.

Note :

GEAR IDLER 2 falls down easily. Take care for its missing.

E. How to re-assemble DRAWER block

A) First insert CARRIAGE 30(63) between ARM(44) and TURN TABLE and set it until inside end. Push SLIDER 2(36) block down and slide it until inside end. CARRIAGE is locked with ARM.

B) How to set CARRIAGES to DRAWER(2)

- 1) Turn GEAR IDLER 2(17) clockwise. The lower PINION in GEAR SUPPORT turns anti-clockwise. After it stops, the upper PINION turns clockwise. Just before the lower PINION starts to turn, stop to turn GEAR IDLER 2. Set CARRIAGE 20(62) as fitting it with the lower PINION as Fig. 8.
- 2) Then push in the left side of CARRIAGE 20 on STAR GEAR C(20) and the rail part by warping the CARRIAGE. (See Fig. 9)
- 3) Turn GEAR IDLER 2(17) clockwise to move CARRIAGE 20 inside. After it reaches innermost, you cannot turn GEAR IDLER 2.
- 4) Then set CARRIAGE 10(12) as same as 20.
- 5) Pulling up CARRIAGE 20 horizontally, turn GEAR IDLER 2 more clockwise.

Then, CARRIAGE 20 is installed and CARRIAGE 10 moves inside by turning GEAR

IDLER 2(17) clockwise.

- 6) After all CARRIAGES are set, turn DRAWER block upside-down. Insert FFC(75) straight into CONNECTOR(73) of CONNECTOR PC BOARD(70) with a pair of tweezers. Take care not to damage the Cable. (You may insert the Cable after item 9), just after fix the right side.)

- 7) In assembly of the left side of CHASSIS, GEAR IDLER A(39) has a direction.(See Fig.8) Set it as its marking faced to the front. (If it doesn't have any marking, no need to take care of direction.)

Note : GEAR IDLER A(39) may fall down. Take care for its missing.

- 8) Move BEVEL GEAR 1(27) to the center of the SHAFT(24).
- 9) First attach the right side hook part of DRAWER block to CHSSIS block and BEVEL GEAR(27) (See Fig. 10). Then move DRAWER block inside as holding its left side up. Fit its left side project into the hole of CHASSIS end.

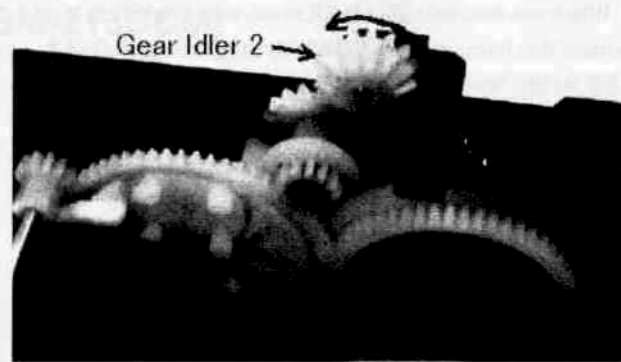

Fig.7

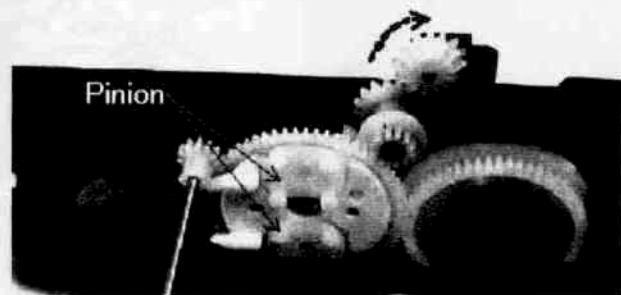

Fig.8

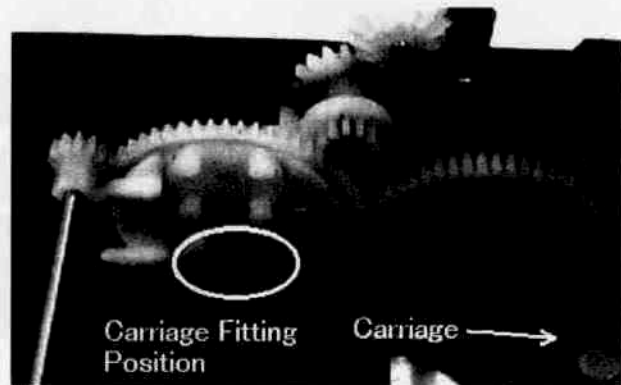

Fig.9

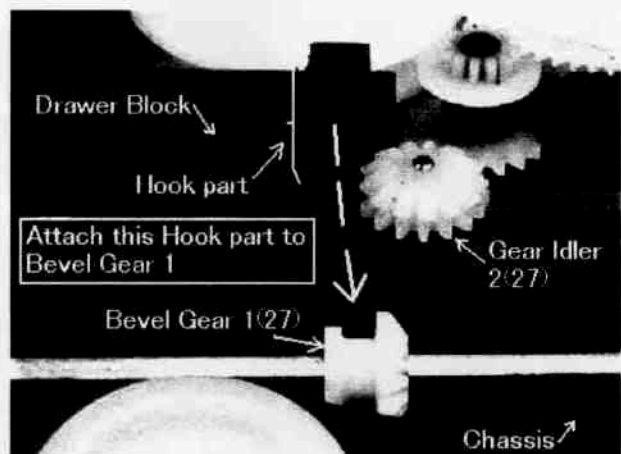

Fig.10

10) When you assemble DRAWER block with CHASSIS, it is important that linear gears in CHASSIS gang well with GEAR IDLER A(39). While GEAR IDLER A isn't ganged well, turn PULLEY B(32) (Fig. 3) a bit and make them ganged. (Take care not to turn it much. GEAR IDLER A should be in +/- 45 degrees from the center.) (See Fig. 11)

11) Push in two hooks at the both sides as they sound click. (You may fix the right side hooks first before you move Drawer block inside in item 9).

12) Put COVER(23) and mount six SCREWS(115).

13) This is a completed or removed condition. (See Fig. 12)

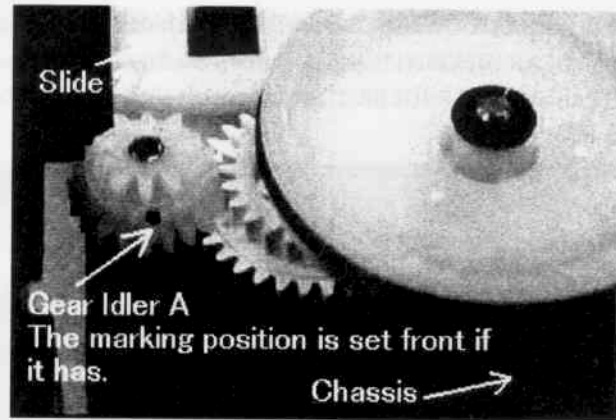

Fig. 11

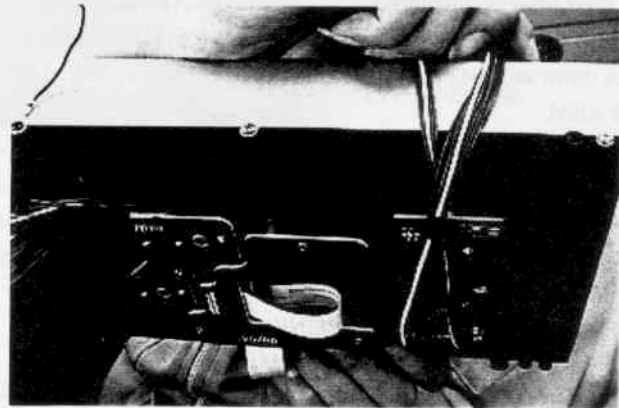
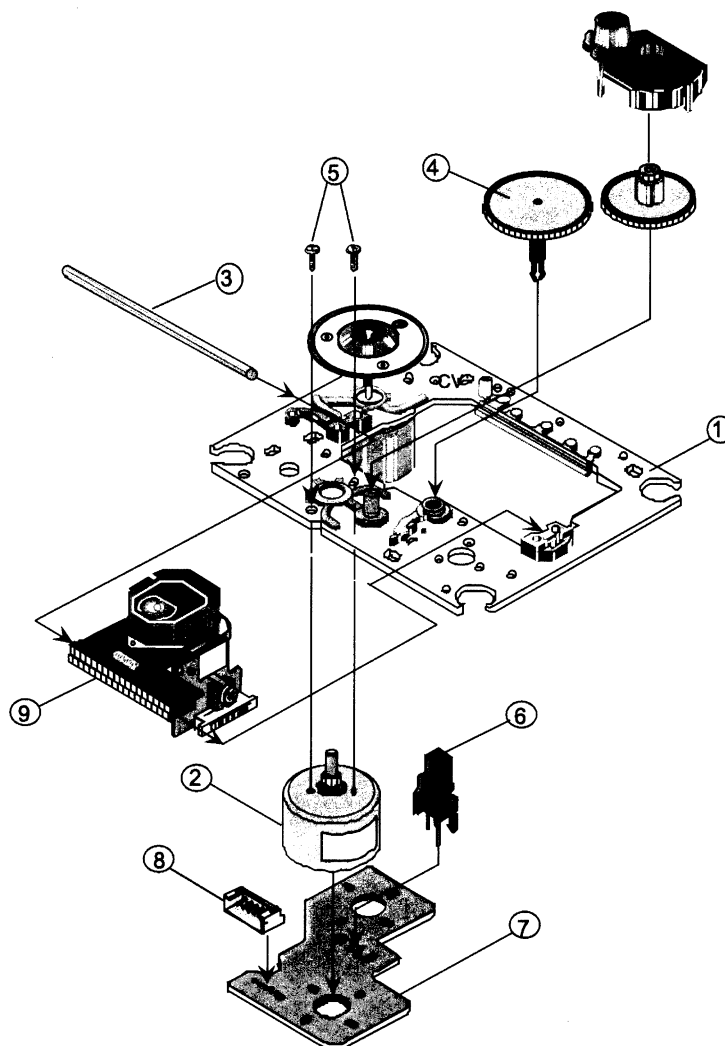

Fig. 12

CD DRIVE UNIT-EXPLODED VIEW (KSM-213CCM)



PARTS LIST

REF.

NO.	PART NO.	DESCRIPTION
1	X2625-877-1	Motor chassis ass'y
2	X2625-769-1	Motor gear ass'y
3	2629-908-01	Sled shaft
4	24810023	Gear A
5	7621-255-15	P2x3, Pan head screw
6	24840008	Leaf switch
7	1639-678-12	Motor pc board
8	1564-722-11	6P, Connection pin
9	8848-483-05	KSS-213C, Optical pickup

MECHANISM-EXPLODED VIEW & PARTS LIST

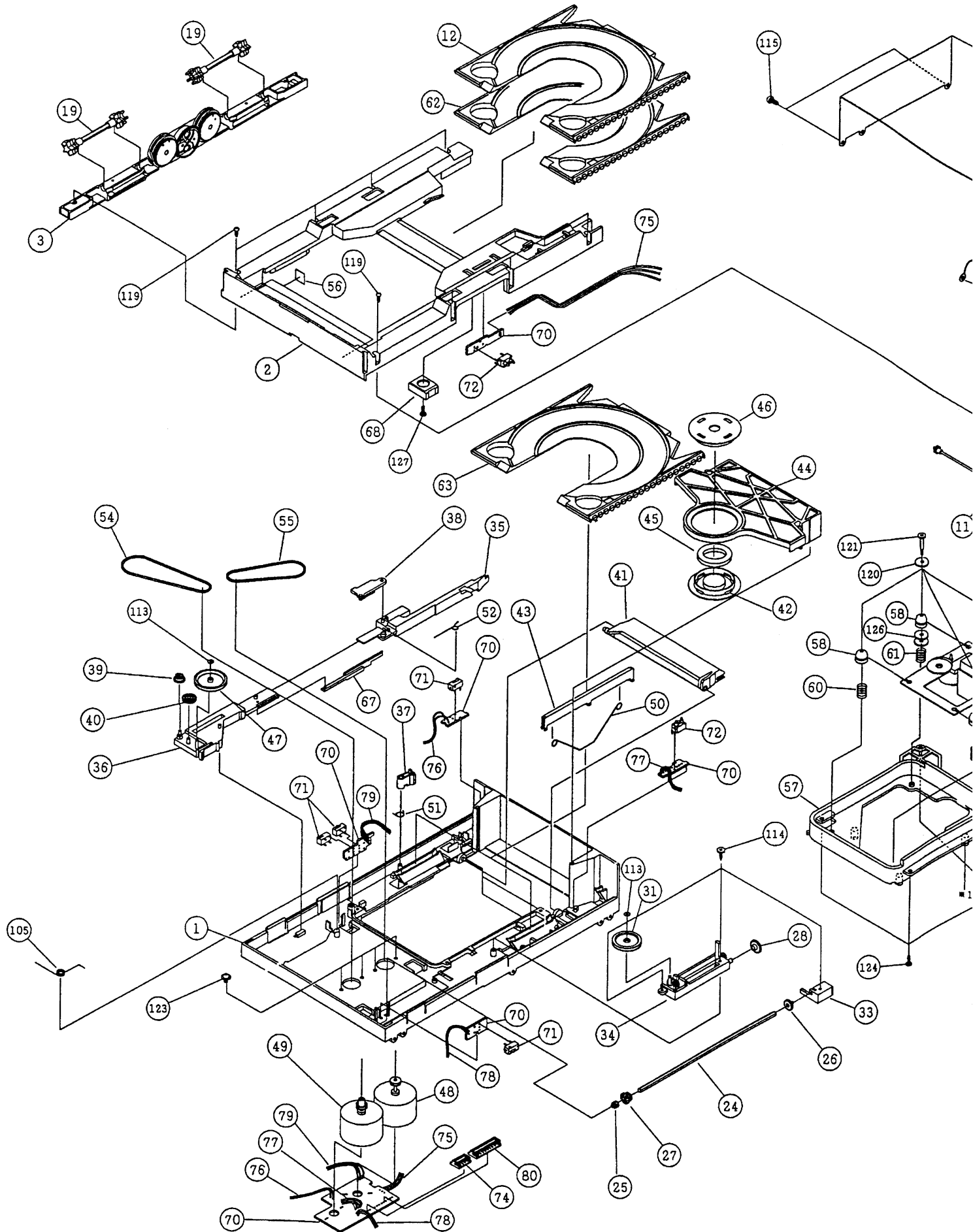

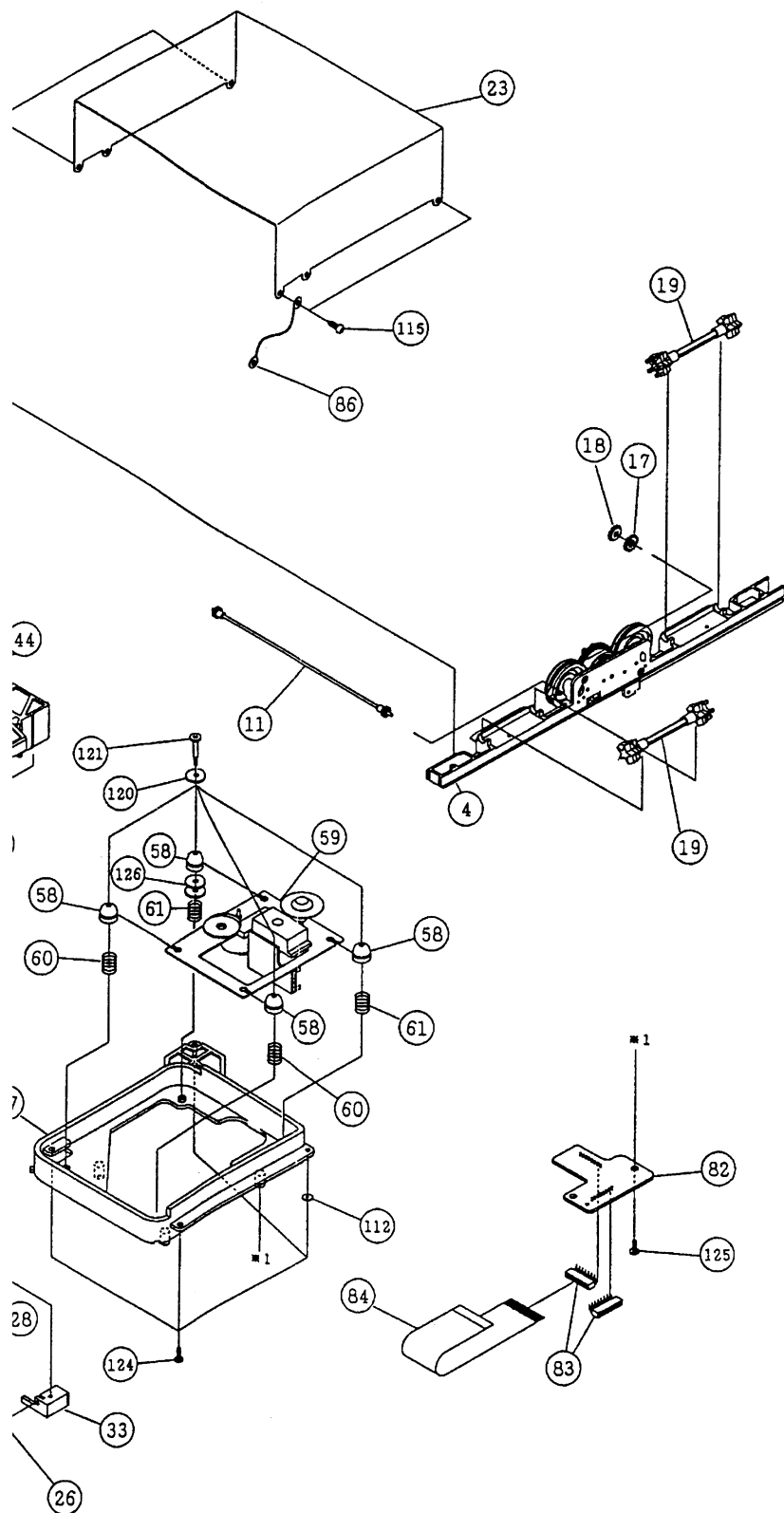

REF. NO.	PART NO.	DESCRIPTION
1	45-093-4160	Chassis AS
2	45-264-4159	Drawer
3	45-211-2006	Holder L
4	45-211-2007	Holder R
11	45-222-4015	Gear, Drive
12	45-264-1109F	Carriage 10
17	45-222-4022	Gear, Idler 2
18	45-222-4060	Bevel, Gear 2
19	45-222-4070	Gear, Start B
23	45-112-3154	Cover 2
24	45-300-4018	Shaft
25	45-262-4019	Cap
26	45-222-4021	Gear Spline
27	45-222-4059	Bevel Gear 1
28	45-222-4026	Gear Idler 1
31	45-222-4058	Pulley C
33	45-219-4062	Holder 2
34	45-219-3055	Holder 1
35	45-259-2031	Slider 1
36	45-259-3066	Slider 2
37	45-239-4064	Arm Stopper A
38	45-239-4065	Arm Stopper B
39	45-222-4128	Gear Idler A
40	45-222-4051	Gear Idler C
41	45-259-3008	Lever
42	45-229-3024	Clamper A
43	45-259-3025	Lifter
44	45-239-1037	Arm
45	36-067-4928	Magnet
46	45-229-3069	Clamper B
47	45-222-4052	Pulley A
48	45-093-4162	Carriage Motor AS
49	45-093-4163	Tray Motor AS
50	01-000-4541	Spring C
51	01-082-4558	Spring
52	01-082-4559	Spring
54	02-083-4167	Belt
55	02-083-4174	Belt
56	45-063-4136	Cushion
57	45-211-3072	Frame
58	45-063-4072	Rubber Cushion
59	KSM213CCM	Pick-Up Drive
60	01-081-4561	Spring
61	01-081-4562	Spring
62	45-264-1110F	Carriage 20
63	45-264-1111F	Carriage 30
67	45-219-4107	Plate E
68	45-219-4127	Spacer
70	45-070-3151	Pc Board (Body)
71	MPU10101MMB0	Switch
72	MPU20273BLB0	Switch
74	S4BEH	Connector
75	45-072-4156	Wire
76	45-070-4080	Wire
77	45-072-4078	Wire
78	45-070-4081	Wire
79	45-072-4079	Wire
80	S9BEH	Connector
82	45-070-4155	Pc Board (Body)
83	16FMNSTRK	Connector
84	45-072-4083	Card Wire
86	PWNC00100XVV	Wire
105	01-082-4577	Spring
112	GWP23X055025	Washer P
113	GWP15X045025S	Washer
114	GSL20A2010	Screw
115	GSL20A2606	Screw
119	GSL10B2006	Screw
120	GSN31X120050	Washer P
121	03-300-4366	Screw
123	GSP14A2604	Screw
124	GSL20A2610	Screw
125	GSL20A2006	Screw
126	03-000-4427	Washer P
127	GST15A2005	Screw

SCHEMATIC DIAGRAM

A

B

C

D

1

2

3

4

5

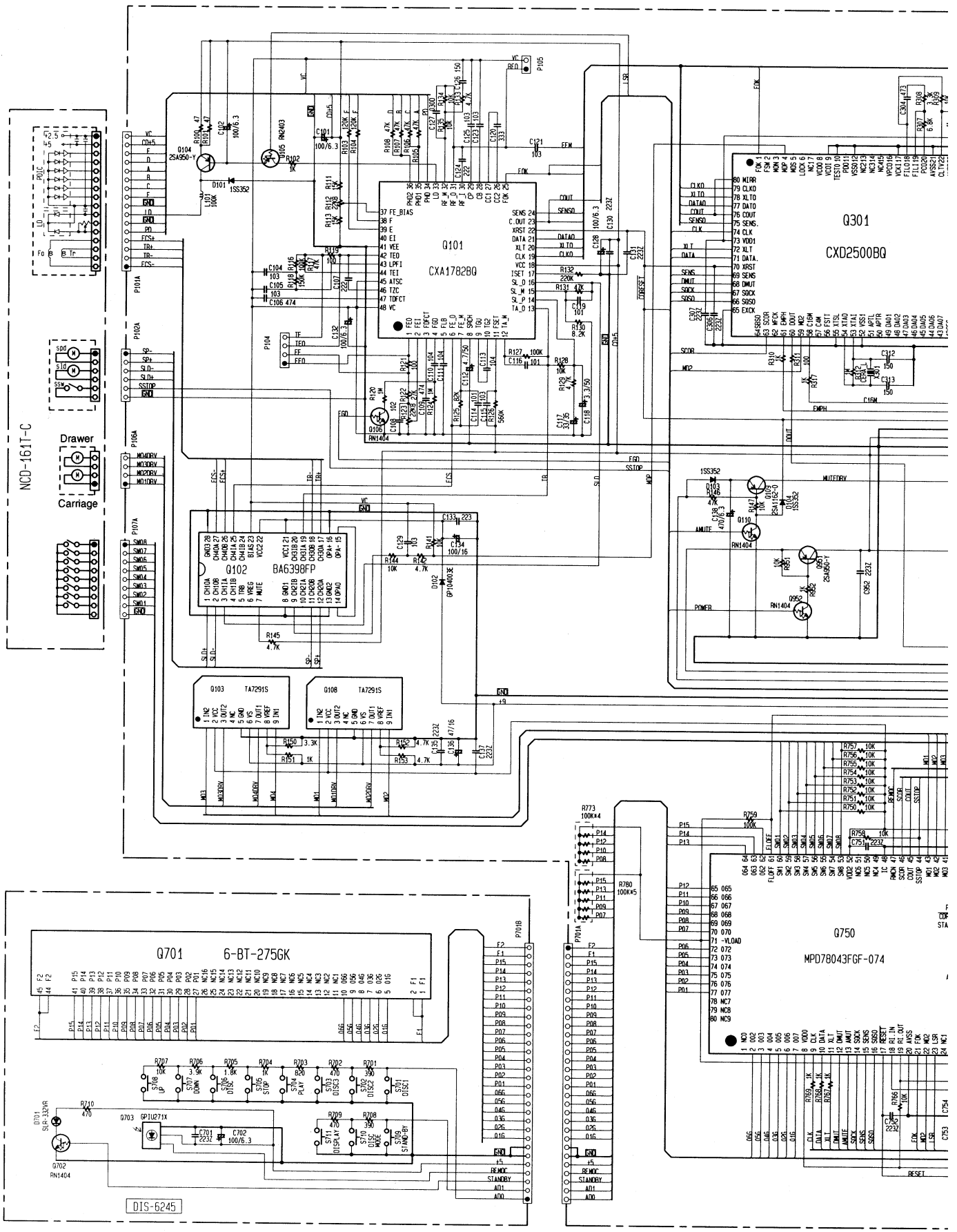

D

E

F

G

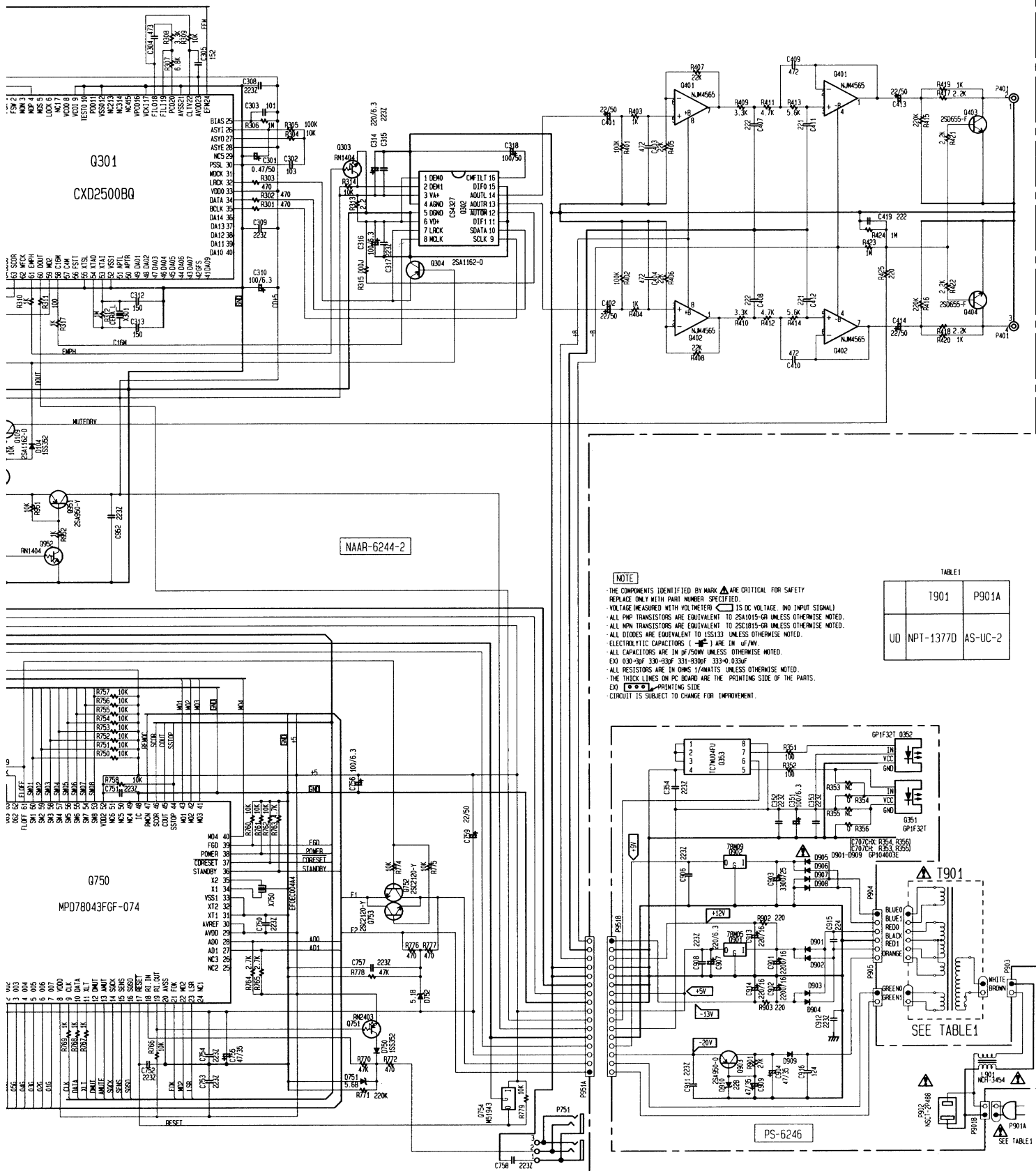

PRINTED CIRCUIT BOARD - PARTS LIST

Main circuit PC board ass'y (NAAR-6244-2)

CIRCUIT NO.	PART NO.	DESCRIPTION
	ICs	
Q101	22241093R3	CXA1782BQ
Q102	22241066R2	BA6398FP
Q103,Q108	22240239	TA7291S
Q301	22240487A	CXD2500BQ
Q302	22241127R2	CS4327-KS
Q401,Q402	22241383R2	NJM4565M-D
Q750	22241482R3	MPD78043FGF-074-3B9
Q754	22240018	M51943A(M51943ASL)
	Transistors	
Q104,Q951	2211504	2SA950-Y
Q105,Q751	2214540R2	RN2403
Q106,Q110 , Q303,Q952	2214490R2	RN1404
Q109,Q304	2214373R2	2SA1162-O
Q403,Q404	2211706	2SD655-F
Q752,Q753	2211164	2SC2120-Y
	Diodes	
D101,D103, D104,D750	223234R2	1SS352
D102	22380035	GP104003E
D751	224490560R2	UDZ5.6B, Zener
D752	224490510R2	UDZ5.1B, Zener
	Coils	
L101	231237K100R2	NCH-1475
L901	231222	NCH-3454
	Sockets	
P101A	25051940	NSCT-16P1727
P101Aor	25051974	NSCT-16P1761
P701A	25051954	NSCT-30P1741
P701Aor	25051988	NSCT-30P1775
P951A	25051527	NSCT-16P1314
	Plugs	
P102A	25055150	NPLG-6P134
P104	25055045	NPLG-4P33
P105	25055038	NPLG-2P29
P106A	25055134	NPLG-4P118
P107A	25055139	NPLG-9P123
	Jacks	
P401	25045512	NPJ-2PDWH326
P751	25045330	NPJ-2PDBL184
	Resistors	
R112,R123	5210294	N06HR22KBE, Semi-fixed Resistor
	Oscillators	
X301	3010308	HC-49/U0316.9344M, Crystal Resonator
X750	3010229	EFOEC004A4, Ceramic Resonator
	Heat sinks	
E104,E106 E104 or	27160145-1 or 27160145	RAD-51
	Screws	
E105,E107	82143010	3P+10FN(BC)

Display circuit PC board ass'y (NADIS-6245-2)

CIRCUIT NO.	PART NO.	DESCRIPTION
	FL Tube	
Q701	212165A	6-BT-275GK
	Transistors	
Q702	2214490R2	RN1404
	LED	
D701	225338	SLR-332VR
	Socket	
P701B	25051912	NSCT-30P1699
	Remote sensor	
Q703	241307	GP1U271X
	Switches	
S701-S707, S709-S700	25035652	NPS-111-S604
S708	25035548	NPS-111-S510
	Holder	
E701	27190941	(FL)
	Power supply circuit PC board ass'y (NAPS-6246-2)	
CIRCUIT NO.	PART NO.	DESCRIPTION
	ICs	
Q353	22240935R2	
Q901	222780055	
Q902	222780095	
	Transistor	
Q903	2211504	
	Photo couplers	
Q351,Q352	24120038	GP1F32T
	Diode	
D901-D909	△ 22380035	GP104003E
D910	224492200R2	UDZ22B, Zener
	Capacitors	
C901,C902	393342227S	CE04W16V-2200M(VX)
C903	393353327S	CE04W25V-3300M(VX)
	Socket	
P902	25050684	NSCT-2P488
	Plugs	
P901B,P903	25055675	NPLG-2P631
P904	25055136	NPLG-6P120
P905	25055146	NPLG-2P130
P951B	25055805	NPLG-16P761

ADJUSTMENT PROCEDURES

Preparation

Set the trimming resistors R112 and R123 to center.

A.Focus offset adjustment

1. Connect the oscilloscope to pin#1(RF) of the socket P105. GND to pin#2(VR)
2. Load the test disc YEDS-18 on the tray and play the track 2.
3. Adjust the trimming resistor R112 so that the waveform(eye pattern) on the oscilloscope becomes maximum. When the output is broad, set R112 to the mechanical center.
4. Remove the oscilloscope.

B.Focus gain adjustment

1. Set the output of the audio oscillator to 1kHz and 1~1.5Vp-p.
2. Connect the oscilloscope and audio oscillator as shown below. (Refer Fig-1)
3. Load the test disc YEDS-18 on the tray and play the track 2.
4. Adjust the trimming resistor R123 so the signal of channel 2 on the oscilloscope becomes 1.25 times of channel 1. (Refer Fig-2)
5. Remove the oscilloscope and audio oscillator.

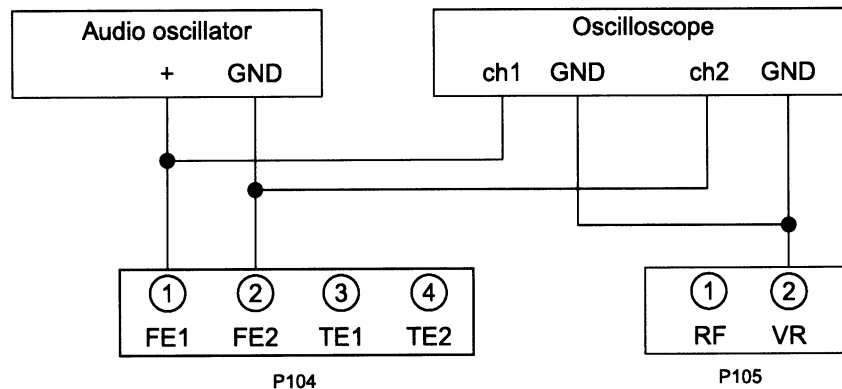

Fig-1

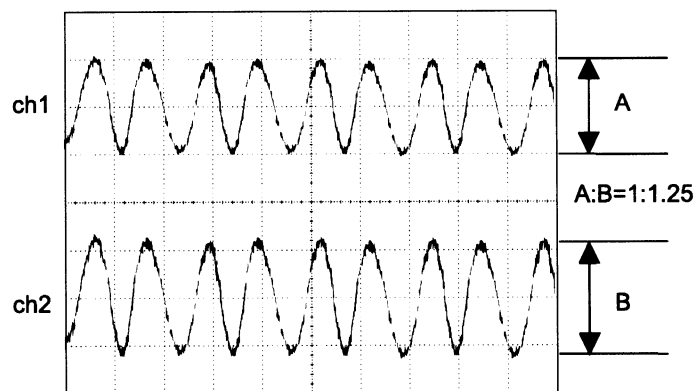

Fig-2

PACKING PARTS LIST

707CHX (T)

REF.

NO.	DESCRIPTION	PART NO.
1	Carton box	29053727
2	Pad ass'y	29091831
3	Poly bag 430*550	29100123C
8	Poly bag t=0.05xD240xW250	29100180
8	Warranty card	29365090
8	Pin cord ass'y	2010098A or 2010244
8	Cord ass'y, RI	2010200
8	Instruction manual	29342876A
	Staple	282321
	UPC Label	29362881

C-707CHX

C-707CHXT

REF.

NO.	PART NO.	DESCRIPTION	PART NO.
1	27111169	Front bracket	27111220
51	27212222	Front panel	27212311
54	28191891	Clear plate	28191891A
58	28148448	Door (CD)	28148478
1	29053562	Carton box	29053727
8	29342876	Instruction manual	29342876A
	29362036	UPC Label	29362881

EXPLODED VIEW PARTS LIST

707CHX (T)

NO.	PART NO.	DESCRIPTION
1	27111220	Front bracket
2	838130088	3TTB+8B, Screw
3	27100360	Chassis
6	831430088	3TTW+8B(BC), Screw
7	830440089	4TTC+8C(BC), Screw
9	27130816A	Bracket (PC)
12	27191046	Holder (M)
14	27175323	Leg ass'y
18	27300750	Bushing S-RELIEF #2271
11	27122701	Rear panel
31	28184783	Top cover
32	838430088	3TTB+8B(BC), Screw
51	27212311	Front panel
52	28198864	Facet
54	28191891A	Clear plate
55	28135279	Badge
58	28148478	Door (CD)
59	27262600	Plate (S)

NO.	PART NO.	DESCRIPTION	NO.
E801	2045301512	NCFC5-301512, Flat cable	54222439
E802	2045161512	NCFC5-161512, Flat cable	1676260174
E803	2002391225	NSAS-12P0656, Socket ass'y	54200717
E804	2001291815	NSAS-18P0657, Socket ass'y	1662860170
E805	2001290815	NSAS-8P0658, Socket ass'y	1660880171
P901A	253279HDK	AS-UC-2#18, Power cord	9
T901	2301428	NPT-1377D, Power transformer	54382080
Z1	24800040	NCD-161T-C, CD mechanism unit	54350632
U1	1H438544-2	NAAR-6244-2, Main circuit PC board ass'y	18 54245391
U2	1H438545-2	NADIS-6245-2, Display circuit PC board ass'y	56369535 1676860144
U3	1H438546-2	NAPS-6246-2, Power supply circuit PC board ass'y	54424571 56397676

NOTE: THE COMPONENTS IDENTIFIED BY MARK !
ARE CRITICAL FOR RISK OF FIRE AND
ELECTRIC SHOCK. REPLACE ONLY WITH
PART NUMBER SPECIFIED.



54
56270503
56296898
54525141

Packing View

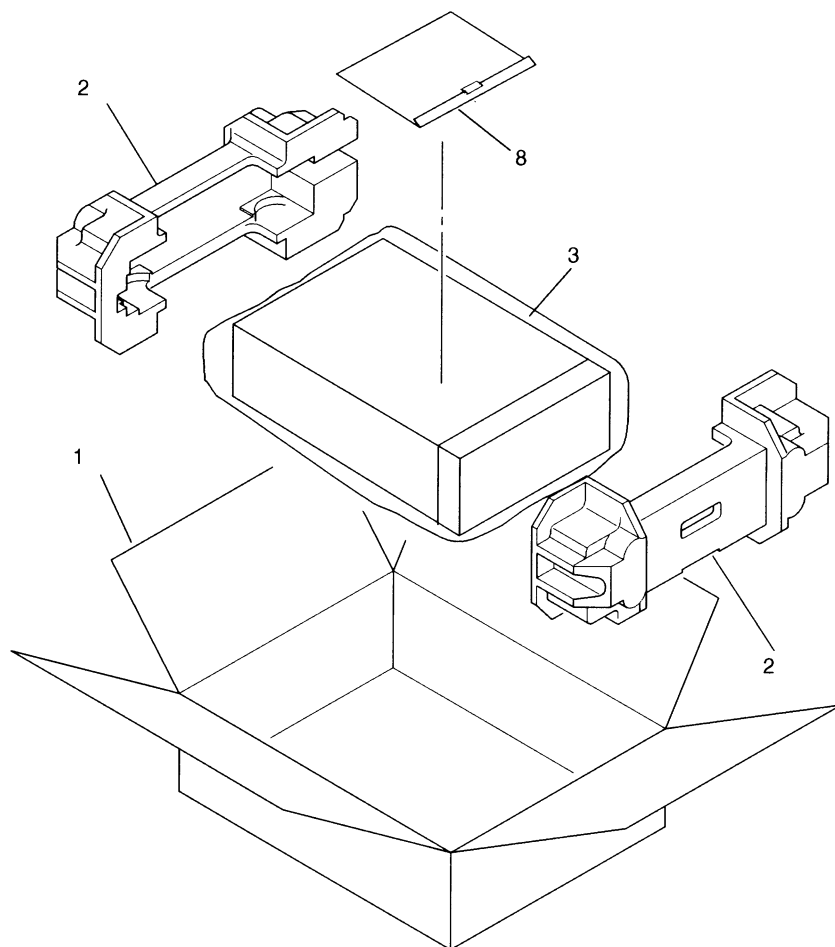
**PARTS LIST**

NO.	PART NO.	DESCRIPTION
1	29053562	Carton
2	29091831	Pad ass'y
3	29100123C	Poly bag, (430*550)
	282321	Staple
	29362036	UPC Label
8	29100180	Poly bag, (T0.05 × D240 × W250)
8	29365083A	Warranty card ass'y
8	29095866	Sheet
8	2010098A or 2010244	Pin cord ass'y
8	2010200	Cord ass'y, RI
8	29342876	Instruction Manual

ONKYO CORPORATION

Sales & Product Planning Div.:2-1, Nisshin-cho, Neyagawa-shi, OSAKA 572, JAPAN
Tel: 072-831-8111 Fax: 072-833-5222

ONKYO U.S.A. CORPORATION

200 Williams Drive, Ramsey, N.J. 07446, U.S.A.
Tel: 201-825-7950 Fax: 201-825-8150 E-Mail: onkyo@onkyousa.com



SN:0M3644 NS006 Printed in Japan