

ONKYO® SERVICE MANUAL

DIRECT DRIVE

AUTOMATIC RETURN TURNTABLE

Model CP-1017A



ONKYO®
AUDIO COMPONENTS

ADJUSTMENT PROCEDURES

1. Auto-return position adjustment

Auto-return position adjustment is made using the adjustment screw in Fig. 1.

2. Tonearm height adjustment

Remove the T.T. mat. Press the cueing button of right side (▼).

Manual operation

Height adjustment is made using the adjustment screw in fig. 2. Adjust the screw for 12—15mm height between the stylus tip and the turntable platter. Turning the screw counterclockwise lowers the tonearm clockwise raises it.

Auto-return and manual operation

Height adjustment of auto-return and manual is made using the adjustment screw in fig. 1. Adjust the screw for 12—15mm height between the stylus tip and turntable platter. Turning the screw clockwise lowers the tonearm counterclockwise raises it.

Note:

The tonearm height adjustment is performed simultaneously for auto-return and manual tonearm raising (by cue). Auto-return and manual cue cannot be adjusted separately.)

3. Microswitch gap adjustment

Adjust the microswitch gap by turning eccentric pin in fig. 2.

Adjust the eccentric pin for 0.3mm gap.

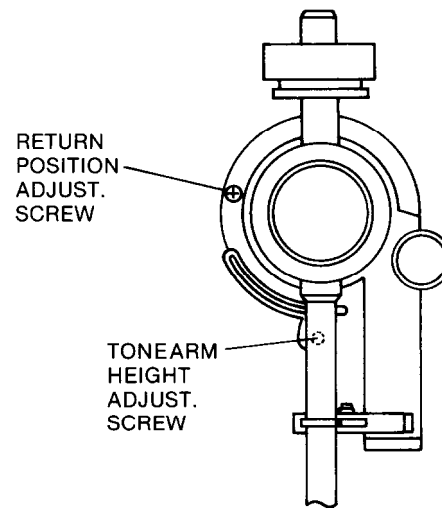

Fig. 1

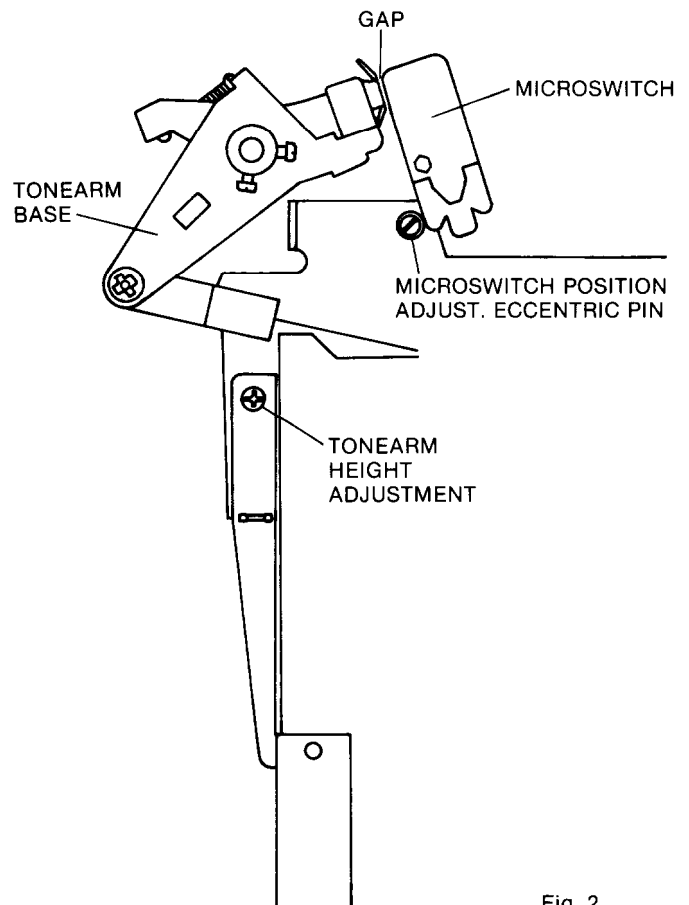

Fig. 2

4. Gear gap adjustment

The gap between the main and T.T gear is adjusted by loosening the motor or auto-return mechanism retaining screws and re-securing the motor or auto-return mechanism when the gap at A and B is 1.3mm.

Adjust the eccentric pin in fig. 3, so that the gap at A and B become same.

5. Speed adjustment

- Set the speed control to center position and confirm that the green L.E.D. lights up.
- Set the speed selector to 33 r.p.m., and adjust VR33 so that the stroboscope stripes appear to be stationary.
- Then switch over to 45 r.p.m., and adjust VR45 to obtain the same stationary stroboscope condition.

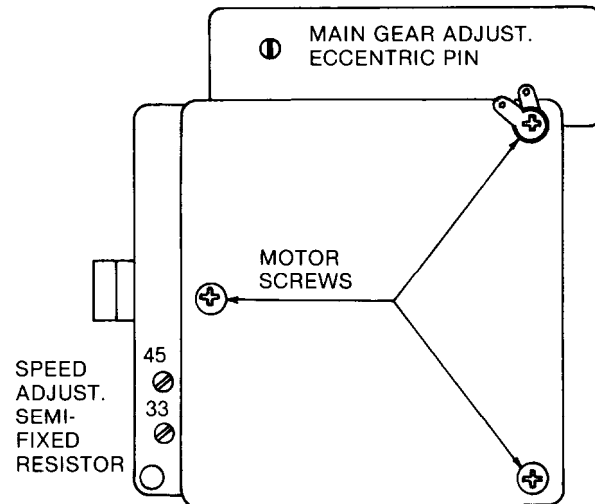

Fig. 3

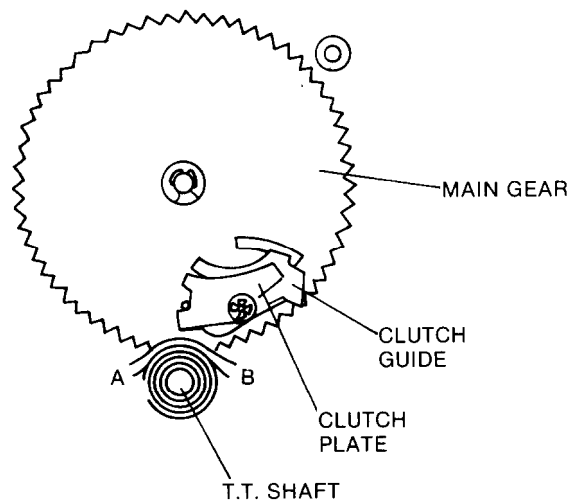

Fig. 4

6. Tonearm lower speed adjustment

- Remove the elevation plate retaining screw in Fig. 5.
- Remove the large circlip. Withdraw the elevation shaft taking care not to damage it.

A. To raise the lowering speed:

Wipe out the (100,000 unit) silicon oil on the spring and area D, and remove a portion of the silicon oil in the oil cup.

B. To lower the lowering speed:

Add (100,000 unit) silicon oil to the oil cup and apply a small amount to area D. Faster lowering speed may be obtained by using a silicon oil of lower viscosity. Before checking the raising or lowering speed, raise and lower the elevation shaft a few times by hand to spread the oil evenly.

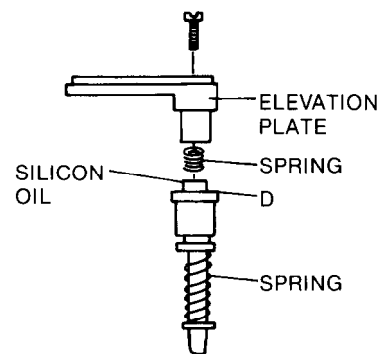
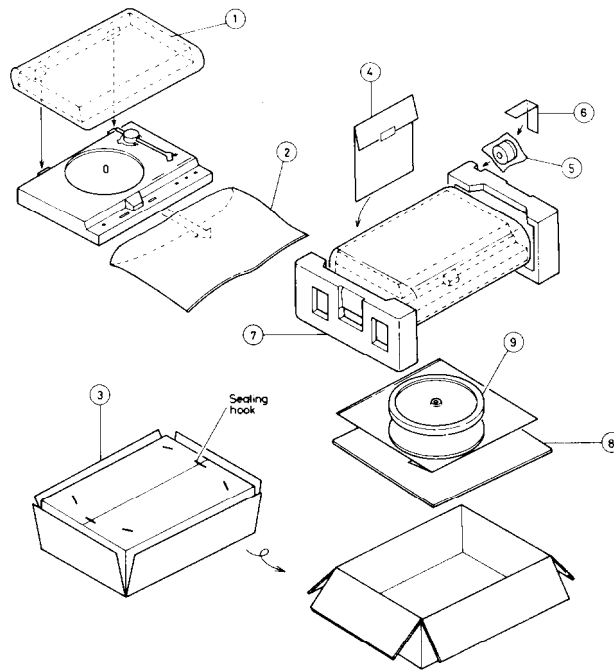

Fig. 5

PACKING PROCEDURES



120V model

REF. NO.	PARTS NO.	DESCRIPTION
1	29100050	Poly bag
2	29100049	460 x 620mm, Poly bag
3	29050518	Master carton box
4		Accessory bag complete
	29340571	Instruction manual
	292049A	45r.p.m. adaptor
	24509197	Over hang gauge
	29365006-2	Warranty card (Only U.S.A. model)
	29358002	Service station list (Only U.S.A. model)
	29100005	220 x 330mm, Poly bag
	24501138	2.6 x 11, Screw for cartridge
	24501123	2.6 x 4, Nut for cartridge
	24500079	Washer for cartridge
5	24501385	Counter weight
	29100002	80 x 150mm, Poly bag
6	260013	W50, P.P. tape
7	29090568	Pad
8	29090566	Pad sheet
9	24509111-1	T.T. mat
	24502120	Turntable platter
	29100046	370 x 470mm, Poly bag

G/U model

REF. NO.	PARTS NO.	DESCRIPTION
1	29100050	Poly bag
2	29100049	460 x 620mm, Poly bag
3	29050518	Master carton box
4		Accessory bag complete
	29340572	Instruction manual
	292049A	45r.p.m. adaptor
	24509197	Over hang gauge
	29365005-2	Warranty card (Only West Germany model)
	25055018	CV-K-1, Conversion plug
5	24501385	Counter weight
	29100002	80 x 150mm, Poly bag
6	260013	W50, P.P. tape
7	29090568	Pad
8	29090566	Pad sheet
9	24509111-1	T.T. mat
	24502120	Turntable platter
	29100046	370 x 470mm, Poly bag

EXPLODED VIEW

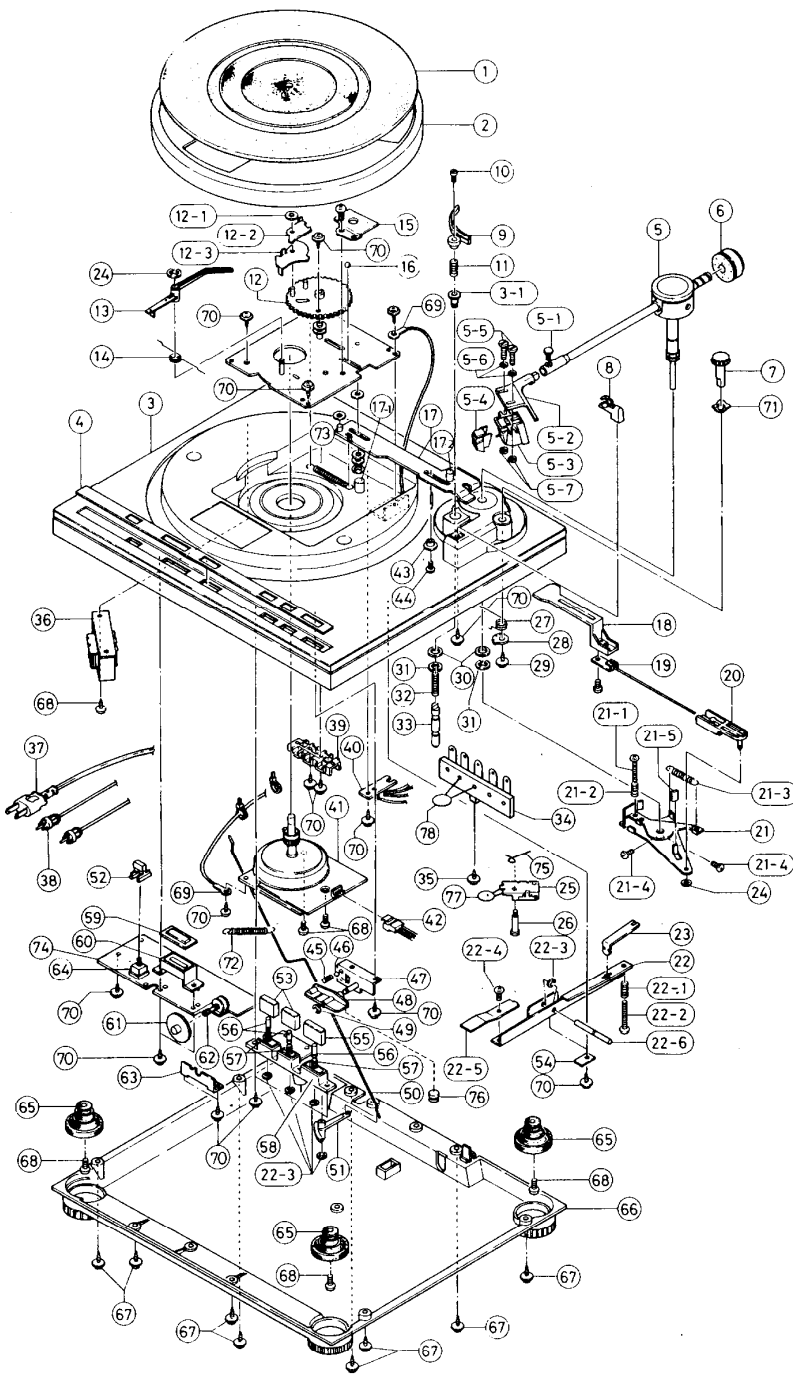

REF. NO.	PARTS NO.	DESCRIPTION
1	24509111-1	T.T. mat
2	24502120	Turntable platter
3	28110231-1	Cabinet ass'y
3-1	27260051	Bearing
4	27262080	Plate
5	24501383	Tonearm ass'y (D)
	24501387	Tonearm ass'y (G/W)
5-1	24501321A	Screw
5-2	24501354	Headshell
5-3	24501308	DN51ST, Stylus (G/W)
5-4	24501346	OC-51M, Cartridge (G/W)
5-5	24501287	2.6x11mm, Screw
5-6	24501123	2.6x4mm, Nut
5-7	24500079	Washer
5-8	245001283	Stylus cover
6	24501385	Counter weight
7	28320490	Knob, IFC
8	28400013	Tonearm rest
9	24501363	Lifter plate
10	24506533	M2x10mm, Screw
11	27180068	Spring
12	24506524A	Automatic return mechanism ass'y
12-2		Clutch plate
12-3		Clutch guide
13	24506532	Reject arm
14	24506431	Reject spring
15	24506531	Plate
16	24506443	Steelball
17	24506529	Slide arm ass'y
17-1		Eccentric pin
17-2		Eccentric pin
18	24506530	Trip lever ass'y
19		Bracket C
20	2450	Trip arm
21	24506525	Tonearm base
21-1		30P + 14FN, Pan head screw
21-2		Spring
21-3		Spring
21-4		3P + 6FN, Pan head screw
22	27140452	Cueing lever ass'y
22-1	27180069	Spring
22-2	82113020	3P + 20FN, Pan head screw
22-3	893030S	ES-3, Circlip
22-4	834130082	3STS + 8BQ, Tapping screw
22-5	27180086	Spring, cueing lever
22-6	27260048	Shaft, cueing lever
23	27140492	Bracket, cueing
24	891030	CS-3, Circlip
25	24503023	K2, Microswitch
26	801228	Screw
27	27180071	Spring, IFC
28	28400012A	Cam, IFC
29	831130100	3TTW + 10P, Tapping screw
30	870073-1	W10x18x0.8', Washer
31	890010	E-8, Circlip
32	27180067	Lifter spring
33	27260049A	Lifter shaft
34	2510004	LG-4C, Terminal
35	831130100	3TTW + 10P, Pan head screw
36	230563	NPT-730D, Power transformer (D)
	230566	NPT-730G, Power transformer (G)
	230567	NPT-730BD, Power transformer (W)
37	253099A	Power supply cable (D)
	253083	Power supply cable (G/W)
38	24505144	Output cable
39	28400010	Holder, cables
40	16627565	NAPS-1065, Power supply terminal pc board (D/G)
	16580547E	NAPS-1047e, Power supply pc board (W)
41	24502121	Motor ass'y
42	25050077	Socket
43	27270057	Spacer
44	831130120	3TTW + 12P, Tapping screw
45	27180070	Spring
46	270555	4φ, Steelball
47	27140450	Cam bracket
48	28400011	Cueing cam ass'y
49	893030S	ES-3, Circlip
50	27260052	Reject lod
51	24506417A	Reject lever
52	28320446	Knob S
53	28320489	Knob M
54	870014	Washer
55	28320488	Knob L
56	24506418A	Slide shaft
57	27180080	Spring
58	27267088A	Guide, knob
59	28191070	Clear plate
60	28133037	Back plate
61	24506402-1	Knob, volume
62	5148051	N16RG2KB15, Speed control variable resistor
63	27140449	Bracket, variable resistor
64	25035215	NPS-122-L179, Speed selector switch
65	24509232	Leg
66	27170086B	Bottom board
67	831130100	3TTW + 10P, Tapping screw
68	833140120	4TTP + 12P, Tapping screw
69	251073	Terminal
70	831130100	3TTW + 10P, Tapping screw
71	870071	Washer
72	27180082	Spring
74	16584509A	NADIS-1009a, Pc board ass'y
75	27180083	Spring
76	27180081	Spring
77	335624730A	Ceramic capacitor
78	335324725	Ceramic capacitor
	24509215	Dust cover
	28180062	Hinge

NOTE: D: Only 120V model
 G: Only 220V model
 W: Only Universal model

SCHEMATIC DIAGRAM

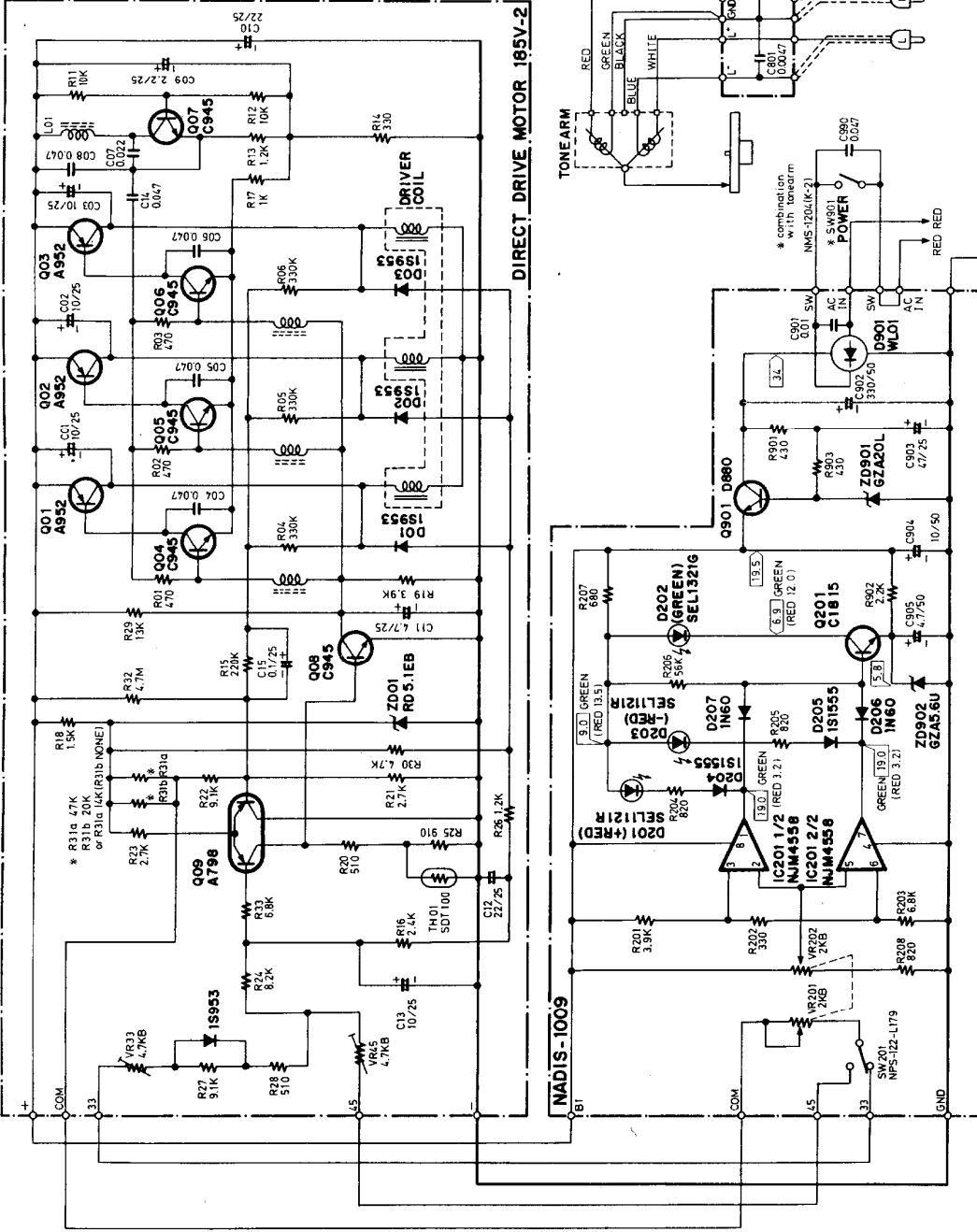

- Q01~Q3 2SA952, 2SB8561, 2SA509, 2SB605
- Q04~Q8 Q04~Q8 (Q09)
- Q201 2SC945, 2SC320, 2SC372, 2SC456
- LC945, 2SC536, 2SC826, JA1350
- 2SC1815, 2SC733, 2SC2021

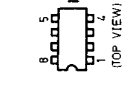
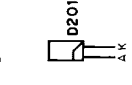
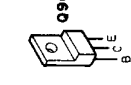
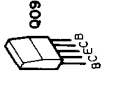

- Q09 2SA798
- 2SA733 x2, 2SA999 x2
- 2SA64 x2, 2SA608 x2
- 2SA640 x2, LA733 x2
- 2SA933 x2, 2SA1015 x2

- Q901 2SD880
- D201, 203 (RED)
- D202 (GREEN)
- SEL1321G

- IC201 NJM4558
- NJM4559

- NOTE
1. ALL RESISTORS ARE IN OHMS, 1/4WATT UNLESS OTHERWISE NOTED.
 2. ALL CAPACITORS ARE IN JF, 50V UNLESS OTHERWISE NOTED.
 3. ELECTROLYTIC CAPACITORS (E-B-) ARE IN JF/WV.
 4. VOLTAGE IS MEASURED WITH V.T.V.M. (□).
 5. CIRCUIT IS SUBJECT TO CHANGE FOR IMPROVEMENT.

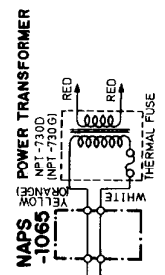
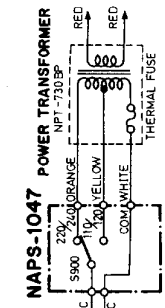

PRINTED CIRCUIT BOARD-PARTS LIST

CIRCUIT NO.	PARTS NO.	DESCRIPTION
	IC	
IC201	222465 or 222534	NJM4558D or NJM4559DX
	Transistors	
Q201	2211255	2SC1815 (GR)
Q901	2201073 or 2201074	2SD880 (O) or 2SD880 (Y)
	Diodes	
D204, D205	223105 or 223133	1S1555 or DS442X
D206, D207	223103	1N60
D901	223862 or 223867	WL01 or WL02

CIRCUIT NO.	PARTS NO.	DESCRIPTION
ZD901	224121	GZA20L
ZD902	224096	GZA5.6U
	Capacitors	
C902	352783319	330 μ F, 50V, Elect.
C903	352754709	47 μ F, 25V, Elect.
C904	352781009	10 μ F, 50V, Elect.
C905	352780479	4.7 μ F, 50V, Elect.
	Resistor	
VR201, VR202	5148051	N16RG2KB15, Speed control variable
	Switch	
SW201	25035215	NPS-122-L179, Speed selector
S900	25065109	NSS-2255P, Voltage selector (Only W model)

1. Attaching the cartridge

Please use the included headshell when attaching the cartridge. The headshell is designed for almost all cartridges on the market today; be careful not to buy a cartridge that is not compatible. In general cartridges with a mass of 5 — 9 grams should be employed.

Attach the cartridge as shown below, connecting each of the color coded lead wires to the proper terminal. If a mistake is made, no sound will be heard or stereo reproduction will be lost. Also, to prevent damage to the stylus during installation operations, leave its cover on or remove the stylus completely.

Use the included overhang gauge as shown placing the cartridge in the gauge and setting the location of the stylus tip as indicated.

- A. Cartridge
 B. Colors of the headshell lead wires and cartridge terminals:
 White: left channel signal (L)
 Blue: left channel ground (LE or LG)
 Red: right channel signal (R)
 Green: right channel ground (RE or RG)

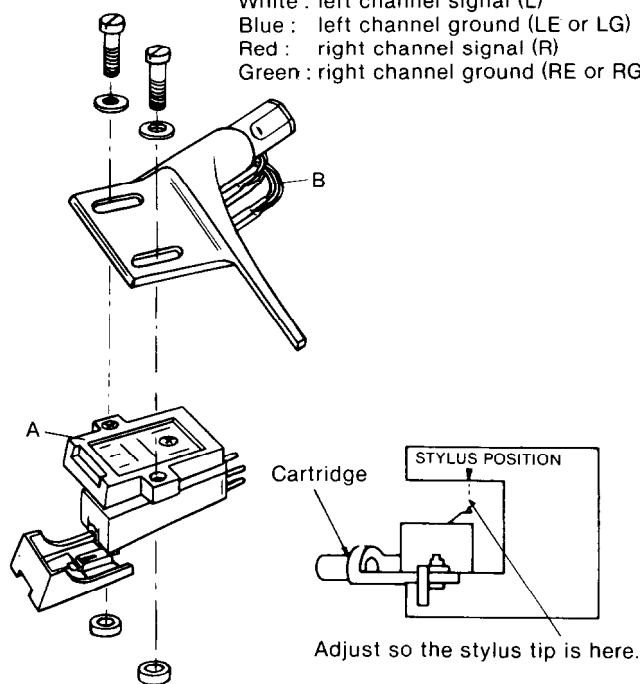

2. Voltage conversion

Before connecting the unit to an AC outlet, check whether it is set for the local AC voltage. The turntable may be set to operate at either 110 ~ 120V or 220 ~ 240V. The voltage selector is under the turntable. If a voltage change is necessary, remove the lock plate, switch to the proper voltage, and replace the plate. Note that the CP-1017A operates at both 50 and 60Hz power frequencies.

Notice:

Some units have been designed to operate only on AC 240V 50Hz or 120V 60Hz, and are consequently not equipped with a voltage selector.

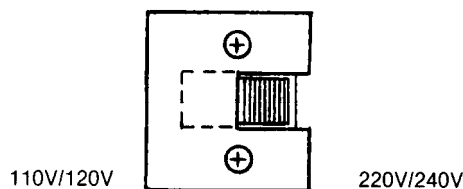

SPECIFICATIONS

D model	
Type :	Direct drive automatic-return turntable
Turntable Platter :	310mm (12-1/4") aluminum die-cast
Motor :	Electronic servo direct drive brushless DC motor
Speeds :	33-1/3, 45r.p.m., adjustable $\pm 3\%$
Wow & Flutter :	less than 0.028% (WRMS)
Signal-to-Noise Ratio :	better than 70dB (DIN B)
Tonearm :	Statically balanced straight type
Effective Arm Length :	224mm (8-7/8")
Overhang :	13mm (1/2")
Maximum Tracking Error :	+3 degrees, -1 degree
Suitable Cartridge Weight :	5 to 9 grams
Power Supply :	AC 120V, 50/60Hz
Dimensions (W x H x D) :	418mm x 135mm x 380mm
	16-1/2" x 5-3/8" x 15"
Weight :	5.0 kg (11 lbs.)

Due to further product improvements, specifications are subject to change without notice.

CP1017AKL

Cartridge	OC-52V V-magnet type (P.N. 24501388)
Frequency Response	20 — 20,000Hz
Impedance	47k Ω
Output	3.5mV
Stylus tip	0.6 mil diamond
Tracking force	2.0 g
Replacement Stylus	DN-52ST (P.N. 24501318)

G/W model	
Type :	2-speed automatic-return turntable
Speeds :	33-1/3, 45r.p.m., adjustable $\pm 3\%$
Wow & Flutter :	0.028% WRMS
Signal-to-Noise Ratio :	70dB (DIN-B)
Tonearm :	Static balanced straight-type pipe arm
	13mm (1/2")
Overhang :	
Cartridge :	OC-51M
Type :	Moving magnet
Recommended Tracking Force :	2 grams
Output Voltage :	3.5mV
Replacement Stylus :	DN-51ST
Power Supply Rating :	AC110 — 120, 220 — 240V
	50/60Hz (or one voltage only)
Dimensions (W x D x H) :	418 x 380 x 135mm
	(16-1/2" x 15" x 5-3/8")
Weight :	5.0 kg (11 lbs.)

Optional Recommended Headshell SH-21F

Due to further product improvements, specifications are subject to change without notice.

ONKYO CORPORATION

International Division: No. 24 Mori Bldg., 23-5, 3-chome, Nishi-Shinbashi, Minato-ku, Tokyo, Japan
Telex: 2423551 ONKYO J. Phone: 03-432-6981

ONKYO U.S.A. CORPORATION

Eastern Office: 200 Williams Drive, Ramsey, N.J. 07446 Tel. 201-825-7950
Midwest Office: 107 North Lively Blvd., Elk Grove, IL 60007 Tel. 312-364-5010
Western Office: 8607 Canoga Ave., Canoga Park, CA, 91304 Tel. 213-314-8114

ONKYO DEUTSCHLAND GMBH, ELECTRONICS

8034 München-Germering, Industriestrasse 18, West Germany. Telex: 521726 Telefon: (089)-84-3071