

Integra SERVICE MANUAL

| |
|------------|
| July, 2009 |
|------------|

BLU-RAY DISC PLAYER MODEL DBS-30.1(B)CDD1N



Black model

RC-731DV

| | |
|---------|----------------|
| B CDD1N | 120 V AC, 60Hz |
|---------|----------------|

SAFETY-RELATED COMPONENT WARNING!!

COMPONENTS IDENTIFIED BY MARK  ON THE SCHEMATIC DIAGRAM AND IN THE PARTS LIST ARE CRITICAL FOR RISK OF FIRE AND ELECTRIC SHOCK. REPLACE THESE COMPONENTS WITH ONKYO PARTS WHOSE PART NUMBERS APPEAR AS SHOWN IN THIS MANUAL.

MAKE LEAKAGE-CURRENT OR RESISTANCE MEASUREMENTS TO DETERMINE THAT EXPOSED PARTS ARE ACCEPTABLY INSULATED FROM THE SUPPLY CIRCUIT BEFORE RETURNING THE APPLIANCE TO THE CUSTOMER.

TABLE OF CONTENTS

| | |
|---|--------|
| Specifications | 1-1-1 |
| Laser Beam Safety Precautions | 1-2-1 |
| Important Safety Precautions | 1-3-1 |
| Standard Notes for Servicing | 1-4-1 |
| Cabinet Disassembly Instructions | 1-5-1 |
| How to Initialize the BLU-RAY Disc Player | 1-6-1 |
| Firmware Renewal Mode | 1-7-1 |
| Block Diagrams | 1-8-1 |
| Schematic Diagrams / CBA and Test Points | 1-9-1 |
| Exploded Views | 1-10-1 |
| Mechanical Parts List | 1-11-1 |
| Electrical Parts List | 1-12-1 |

Manufactured under license from Dolby Laboratories.
Dolby and the double-D symbol are trademarks of Dolby Laboratories.

SPECIFICATIONS

| General | |
|-------------------------------------|--|
| Signal system | NTSC color |
| Power requirements | 120V AC, 60Hz |
| Power consumption | 22W (standby: 0.7W) |
| Dimensions (width x height x depth) | 17 ^{-1/8} x 2 ^{-3/4} x 12 ^{-3/16} inches (435 x 69.3 x 310mm) |
| Weight | 6.6 lbs (3.0kg) |
| Operating temperature | 41°F (5°C) to 104°F (40°C) |
| Operating humidity | Less than 80% (no condensation) |

| Terminals | | |
|--------------------------|--|--|
| Rear | Audio output (Analog) | |
| | RCA jack x 2 | L/R: 2Vrms (output impedance: more than 1kΩ) |
| | Video output | |
| | RCA jack x 1 | 1Vp-p (75Ω) |
| | Component video output | |
| | RCA jack x 3 | Y: 1Vp-p (75Ω) PB: 700mVp-p (75Ω) PR: 700mVp-p (75Ω) |
| | Audio output (Digital) | |
| | RCA jack x 1 | 500mVp-p (75Ω) |
| | Optical jack x 1 | Digital connector |
| | HDMI output | |
| HDMI jack x 1 | Video: 480p, 720p, 1080i, 1080p, 1080p24 / Audio | |
| ETHERNET terminal | 10BASE-T/100BASE-TX | |

Note

- The specifications and design of this product are subject to change without notice.

LASER BEAM SAFETY PRECAUTIONS

This BD player uses a pickup that emits a laser beam.

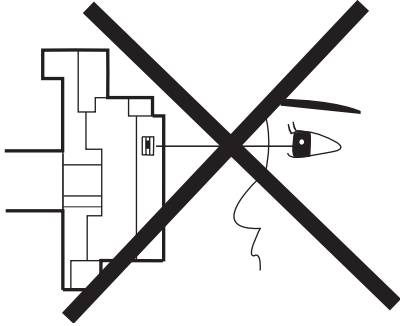

Do not look directly at the laser beam coming from the pickup or allow it to strike against your skin.

The laser beam is emitted from the location shown in the figure. When checking the laser diode, be sure to keep your eyes at least 30 cm away from the pickup lens when the diode is turned on. Do not look directly at the laser beam.

CAUTION: Use of controls and adjustments, or doing procedures other than those specified herein, may result in hazardous radiation exposure.

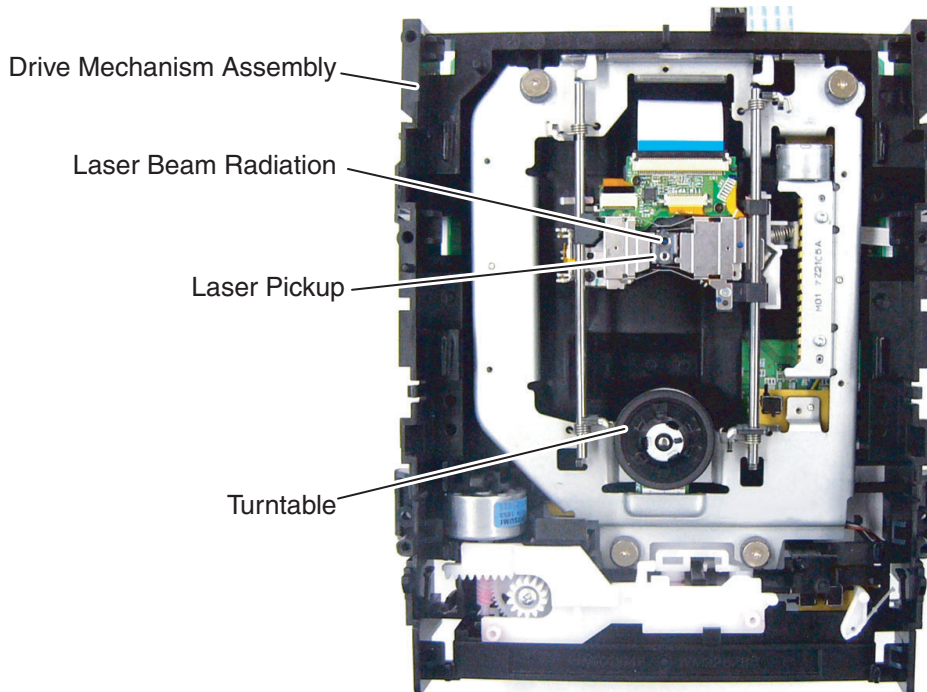

CAUTION - LASER RADIATION WHEN OPEN.
DO NOT STARE INTO BEAM. (FDA 21CFR/Class II)

CAUTION - CLASS 2 LASER RADIATION WHEN OPEN
DO NOT STARE INTO THE BEAM (IEC60825-1/Class 2)

ATTENTION - RAYONNEMENT LASER DE CLASSE 2 EN CAS D'OUVERTURE
NE PAS REGARDER DANS LE FAISCEAU

注意 - ここを覗くとクラス2のレーザー放射が出る
ビームをのぞき込まないこと

Location: Inside Top of BD mechanism.

IMPORTANT SAFETY PRECAUTIONS

Product Safety Notice

Some electrical and mechanical parts have special safety-related characteristics which are often not evident from visual inspection, nor can the protection they give necessarily be obtained by replacing them with components rated for higher voltage, wattage, etc. Parts that have special safety characteristics are identified by a **▲** on schematics and in parts lists. Use of a substitute replacement that does not have the same safety characteristics as the recommended replacement part might create shock, fire, and/or other hazards. The Product's Safety is under review continuously and new instructions are issued whenever appropriate. Prior to shipment from the factory, our products are carefully inspected to confirm with the recognized product safety and electrical codes of the countries in which they are to be sold. However, in order to maintain such compliance, it is equally important to implement the following precautions when a set is being serviced.

- I. Also check areas surrounding repaired locations.
- J. Be careful that foreign objects (screws, solder droplets, etc.) do not remain inside the set.
- K. When connecting or disconnecting the internal connectors, first, disconnect the AC plug from the AC outlet.

Precautions during Servicing

- A. Parts identified by the **▲** symbol are critical for safety. Replace only with part number specified.
- B. In addition to safety, other parts and assemblies are specified for conformance with regulations applying to spurious radiation. These must also be replaced only with specified replacements. Examples: RF converters, RF cables, noise blocking capacitors, and noise blocking filters, etc.
- C. Use specified internal wiring. Note especially:
 - 1) Wires covered with PVC tubing
 - 2) Double insulated wires
 - 3) High voltage leads
- D. Use specified insulating materials for hazardous live parts. Note especially:
 - 1) Insulation tape
 - 2) PVC tubing
 - 3) Spacers
 - 4) Insulators for transistors
- E. When replacing AC primary side components (transformers, power cord, etc.), wrap ends of wires securely about the terminals before soldering.
- F. Observe that the wires do not contact heat producing parts (heat sinks, oxide metal film resistors, fusible resistors, etc.).
- G. Check that replaced wires do not contact sharp edges or pointed parts.
- H. When a power cord has been replaced, check that 5 - 6 kg of force in any direction will not loosen it.

Safety Check after Servicing

Examine the area surrounding the repaired location for damage or deterioration. Observe that screws, parts, and wires have been returned to their original positions. Afterwards, do the following tests and confirm the specified values to verify compliance with safety standards.

1. Clearance Distance

When replacing primary circuit components, confirm specified clearance distance (d) and (d') between soldered terminals, and between terminals and surrounding metallic parts. (See Fig. 1)

Table 1: Ratings for selected area

| AC Line Voltage | Clearance Distance (d), (d') |
|-----------------|---|
| 120 V | $\geq 3\text{mm}(d)$ $\geq 4\text{mm}(d')$ |

Note: This table is unofficial and for reference only. Be sure to confirm the precise values.

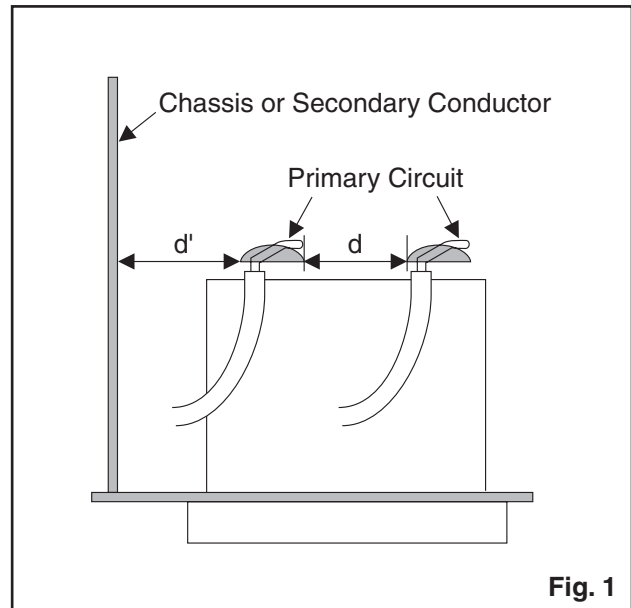

Fig. 1

2. Leakage Current Test

Confirm the specified (or lower) leakage current between B (earth ground, power cord plug prongs) and externally exposed accessible parts (RF terminals, antenna terminals, video and audio input and output terminals, microphone jacks, earphone jacks, etc.) is lower than or equal to the specified value in the table below.

Measuring Method (Power ON):

Insert load Z between B (earth ground, power cord plug prongs) and exposed accessible parts. Use an AC voltmeter to measure across the terminals of load Z. See Fig. 2 and the following table.

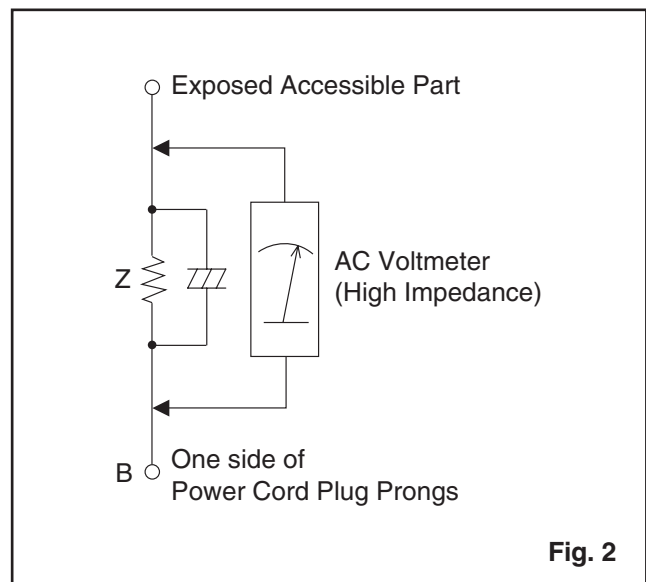

Fig. 2

Table 2: Leakage current ratings for selected areas

| AC Line Voltage | Load Z | Leakage Current (i) | One side of power cord plug prongs (B) to: |
|-----------------|--|---|--|
| 120 V | 2k Ω RES. Connected in parallel | $i \leq 0.7\text{mA AC Peak}$ $i \leq 2\text{mA DC}$ | RF or Antenna terminals |
| | 50k Ω RES. Connected in parallel | $i \leq 0.7\text{mA AC Peak}$ $i \leq 2\text{mA DC}$ | A/V Input, Output |

Note: This table is unofficial and for reference only. Be sure to confirm the precise values.

STANDARD NOTES FOR SERVICING

Circuit Board Indications

1. The output pin of the 3 pin Regulator ICs is indicated as shown.

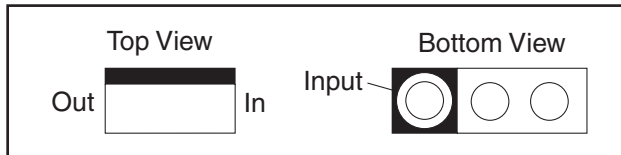

2. For other ICs, pin 1 and every fifth pin are indicated as shown.

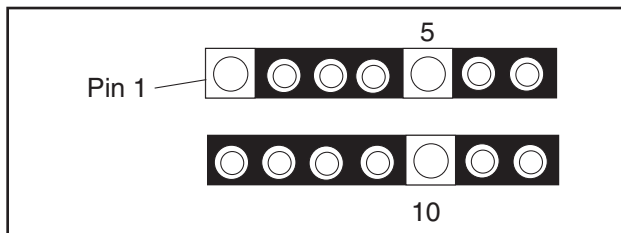

3. The 1st pin of every male connector is indicated as shown.

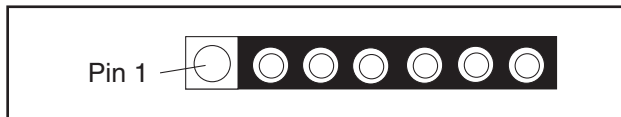

Instructions for Connectors

1. When you connect or disconnect the FFC (Flexible Foil Connector) cable, be sure to first disconnect the AC cord.
2. FFC (Flexible Foil Connector) cable should be inserted parallel into the connector, not at an angle.

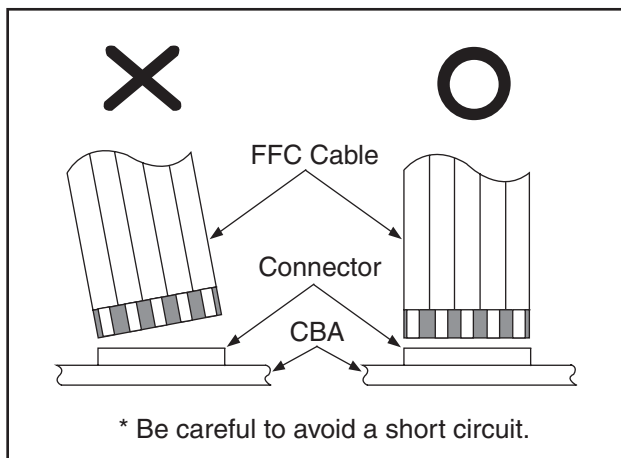

Pb (Lead) Free Solder

When soldering, be sure to use the Pb free solder.

How to Remove / Install Flat Pack-IC

1. Removal

With Hot-Air Flat Pack-IC Desoldering Machine:

1. Prepare the hot-air flat pack-IC desoldering machine, then apply hot air to the Flat Pack-IC (about 5 to 6 seconds). (Fig. S-1-1)

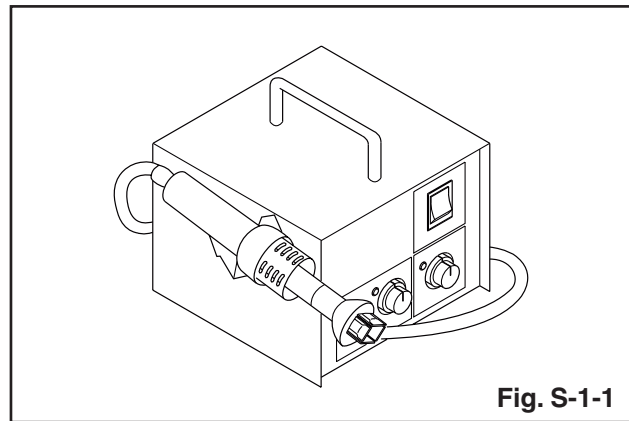

2. Remove the flat pack-IC with tweezers while applying the hot air.
3. Bottom of the flat pack-IC is fixed with glue to the CBA; when removing entire flat pack-IC, first apply soldering iron to center of the flat pack-IC and heat up. Then remove (glue will be melted). (Fig. S-1-6)
4. Release the flat pack-IC from the CBA using tweezers. (Fig. S-1-6)

CAUTION:

1. The Flat Pack-IC shape may differ by models. Use an appropriate hot-air flat pack-IC desoldering machine, whose shape matches that of the Flat Pack-IC.
2. Do not supply hot air to the chip parts around the flat pack-IC for over 6 seconds because damage to the chip parts may occur. Put masking tape around the flat pack-IC to protect other parts from damage. (Fig. S-1-2)

3. The flat pack-IC on the CBA is affixed with glue, so be careful not to break or damage the foil of each pin or the solder lands under the IC when removing it.

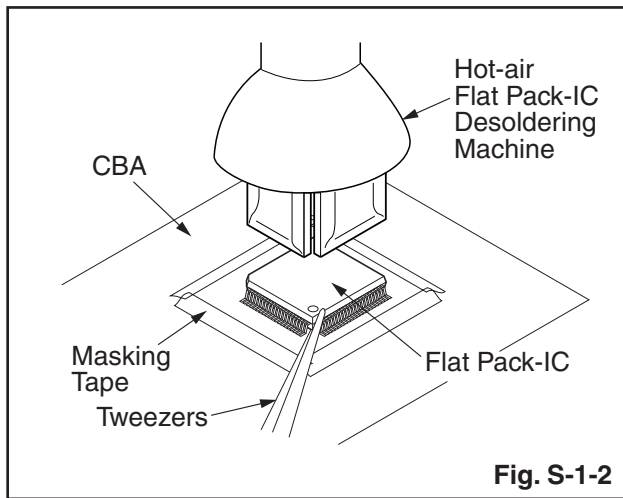

With Soldering Iron:

1. Using desoldering braid, remove the solder from all pins of the flat pack-IC. When you use solder flux which is applied to all pins of the flat pack-IC, you can remove it easily. (Fig. S-1-3)

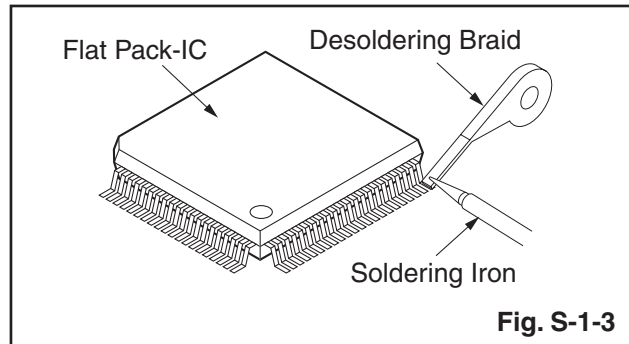

2. Lift each lead of the flat pack-IC upward one by one, using a sharp pin or wire to which solder will not adhere (iron wire). When heating the pins, use a fine tip soldering iron or a hot air desoldering machine. (Fig. S-1-4)

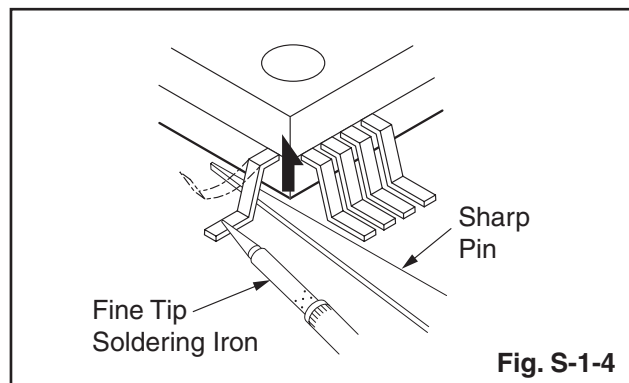

3. Bottom of the flat pack-IC is fixed with glue to the CBA; when removing entire flat pack-IC, first apply soldering iron to center of the flat pack-IC and heat up. Then remove (glue will be melted). (Fig. S-1-6)
4. Release the flat pack-IC from the CBA using tweezers. (Fig. S-1-6)

With Iron Wire:

1. Using desoldering braid, remove the solder from all pins of the flat pack-IC. When you use solder flux which is applied to all pins of the flat pack-IC, you can remove it easily. (Fig. S-1-3)
2. Affix the wire to a workbench or solid mounting point, as shown in Fig. S-1-5.
3. While heating the pins using a fine tip soldering iron or hot air blower, pull up the wire as the solder melts so as to lift the IC leads from the CBA contact pads as shown in Fig. S-1-5.
4. Bottom of the flat pack-IC is fixed with glue to the CBA; when removing entire flat pack-IC, first apply soldering iron to center of the flat pack-IC and heat up. Then remove (glue will be melted). (Fig. S-1-6)
5. Release the flat pack-IC from the CBA using tweezers. (Fig. S-1-6)

Note: When using a soldering iron, care must be taken to ensure that the flat pack-IC is not being held by glue. When the flat pack-IC is removed from the CBA, handle it gently because it may be damaged if force is applied.

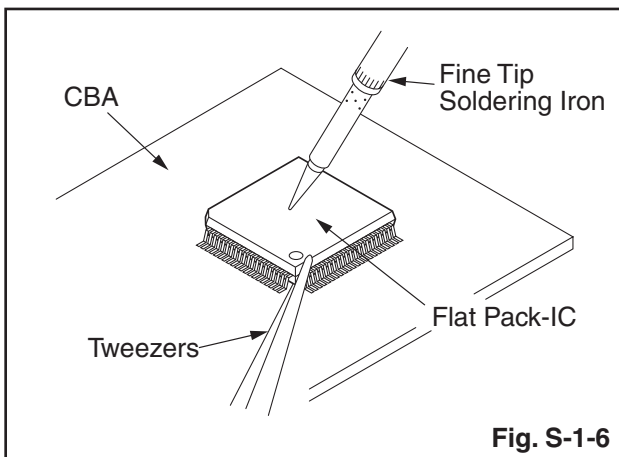
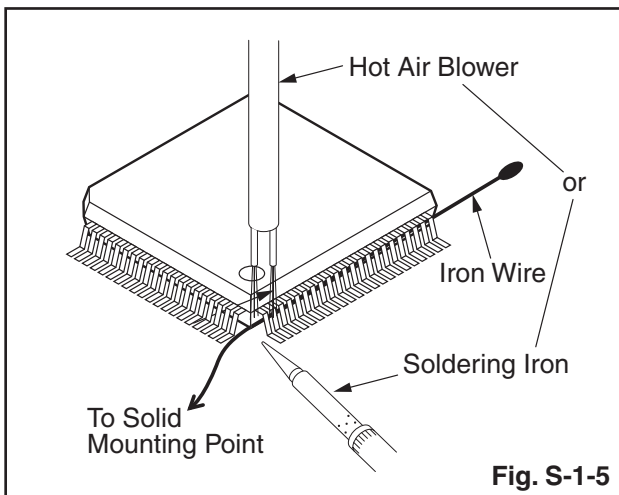

2. Installation

1. Using desoldering braid, remove the solder from the foil of each pin of the flat pack-IC on the CBA so you can install a replacement flat pack-IC more easily.
2. The "●" mark on the flat pack-IC indicates pin 1. (See Fig. S-1-7.) Be sure this mark matches the pin 1 on the PCB when positioning for installation. Then presolder the four corners of the flat pack-IC. (See Fig. S-1-8.)
3. Solder all pins of the flat pack-IC. Be sure that none of the pins have solder bridges.

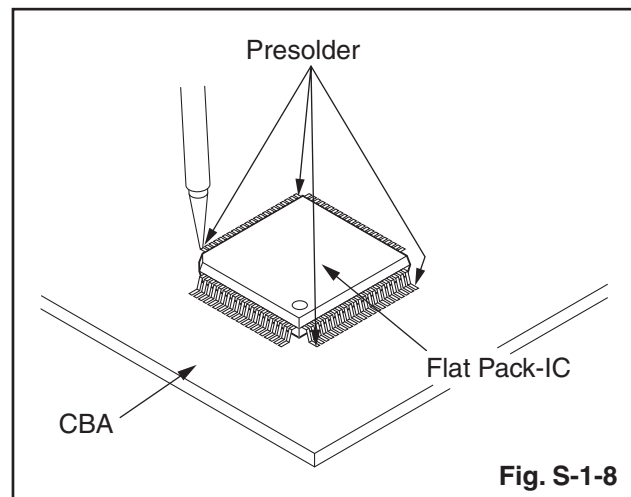
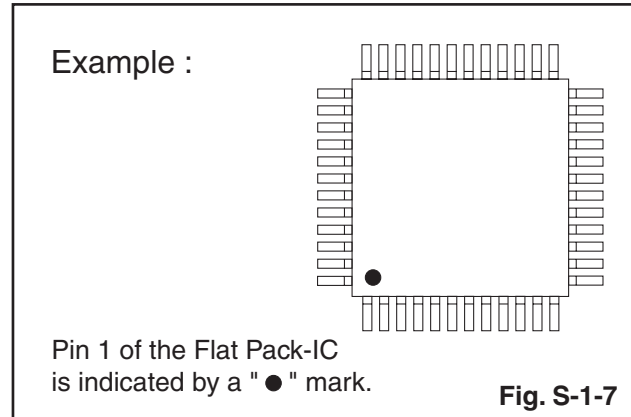

Instructions for Handling Semi-conductors

Electrostatic breakdown of the semi-conductors may occur due to a potential difference caused by electrostatic charge during unpacking or repair work.

1. Ground for Human Body

Be sure to wear a grounding band (1 M Ω) that is properly grounded to remove any static electricity that may be charged on the body.

2. Ground for Workbench

Be sure to place a conductive sheet or copper plate with proper grounding (1 M Ω) on the workbench or other surface, where the semi-conductors are to be placed. Because the static electricity charge on clothing will not escape through the body grounding band, be careful to avoid contacting semi-conductors with your clothing.

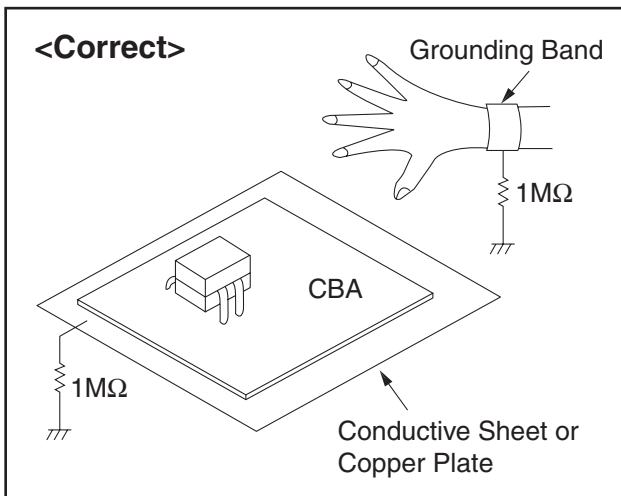
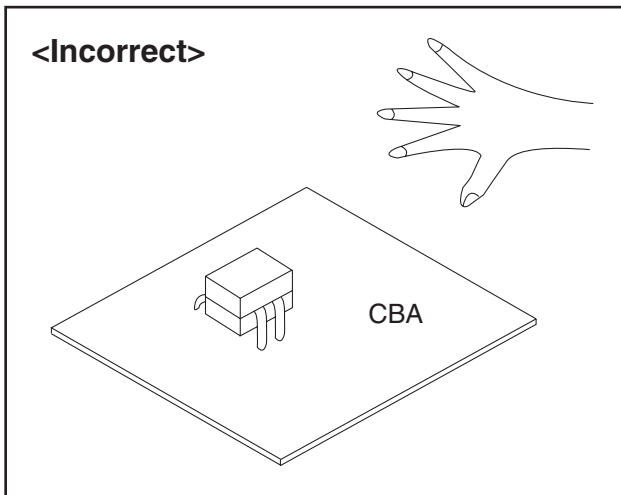

CABINET DISASSEMBLY INSTRUCTIONS

1. Disassembly Flowchart

This flowchart indicates the disassembly steps to gain access to item(s) to be serviced. When reassembling, follow the steps in reverse order. Bend, route, and dress the cables as they were originally.

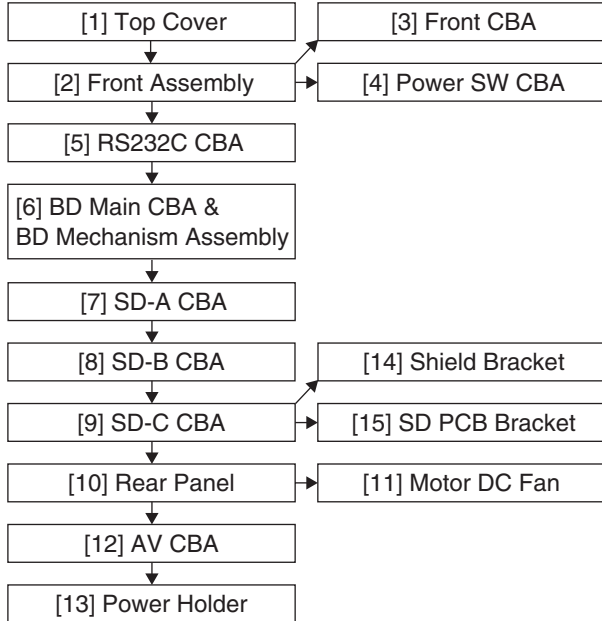

2. Disassembly Method

| ID/ Loc. No. | Part | Removal | | |
|--------------------|-------------------------------------|-------------|---|------|
| | | Fig. No. | Remove/*Unhook/ Unlock/Release/ Unplug/Desolder | Note |
| [1] | Top Cover | D1 | 9(S-1) | --- |
| [2] | Front Assembly | D2 | *5(L-1), *3(L-2), *5(S-2) *CN2002, *CN3001 | 1 |
| [3] | Front CBA | D2 | ----- | --- |
| [4] | Power SW CBA | D2 | ----- | --- |
| [5] | RS232C CBA | D3 | 2(S-3), *CN2006 | --- |
| [6] | BD Main CBA & BD Mechanism Assembly | D3 | (S-4), 2(S-5), 4(S-6), 2(S-7), 4(S-8), *CN6001, *CN7101, *CN7601, Main PCB Earth Plate, Front Shield | 2 |
| [7] | SD-A CBA | D3 | Desolder | --- |
| [8] | SD-B CBA | D3 | Desolder | --- |
| [9] | SD-C CBA | D3 | ----- | --- |
| [10] | Rear Panel | D4 | 2(S-9), 4(S-10), 2(S-11), (S-12) | --- |

| ID/ Loc. No. | Part | Removal | | |
|--------------------|----------------|-------------|---|------|
| | | Fig. No. | Remove/*Unhook/ Unlock/Release/ Unplug/Desolder | Note |
| [11] | Motor DC Fan | D4 | *CN2004, Fan Holder | --- |
| [12] | AV CBA | D5 | 5(S-13) | --- |
| [13] | Power Holder | D5 | (S-14) | --- |
| [14] | Shield Bracket | D5 | 4(S-15) | --- |
| [15] | SD PCB Bracket | D5 | (S-16) | --- |

↓ ↓ ↓ ↓ ↓
 (1) (2) (3) (4) (5)

Note:

- (1) Identification (location) No. of parts in the figures
- (2) Name of the part
- (3) Figure Number for reference
- (4) Identification of parts to be removed, unhooked, unlocked, released, unplugged, unclamped, or desoldered.
P = Spring, L = Locking Tab, S = Screw, CN = Connector
* = Unhook, Unlock, Release, Unplug, or Desolder
e.g. 2(S-2) = two Screws (S-2),
2(L-2) = two Locking Tabs (L-2)
- (5) Refer to "Reference Notes."

Reference Notes

- CAUTION 1:** Locking Tabs (L-1) and (L-2) are fragile. Be careful not to break them.
- The BD Main CBA & BD Mechanism Assembly is adjusted as a unit at factory. Therefore, do not disassemble it. Replace the BD Main CBA & BD Mechanism Assembly as a unit.**

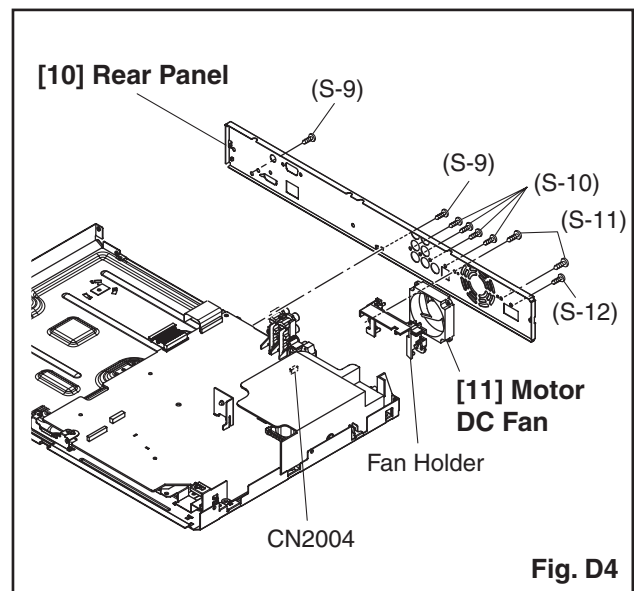
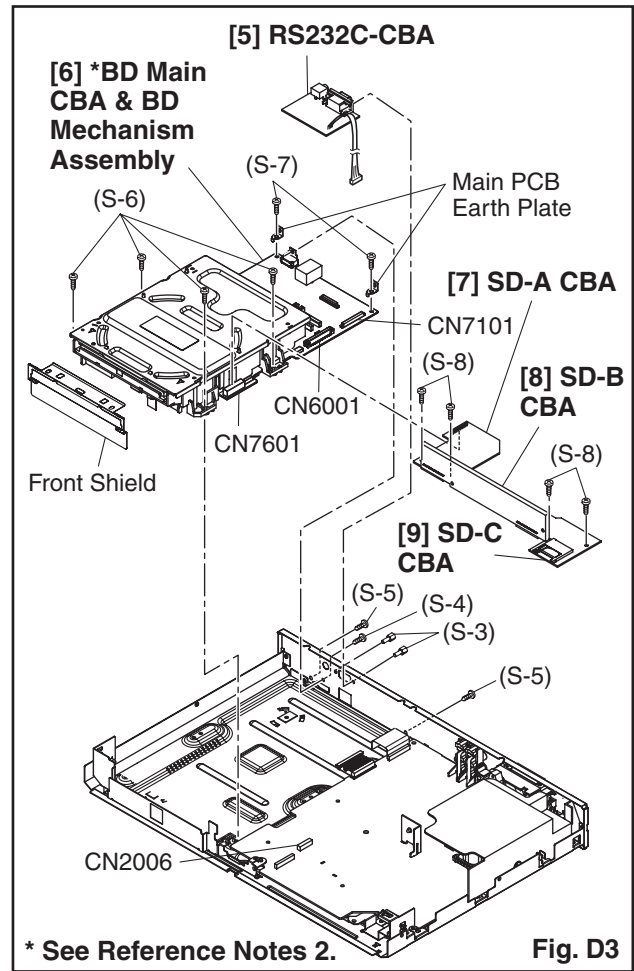
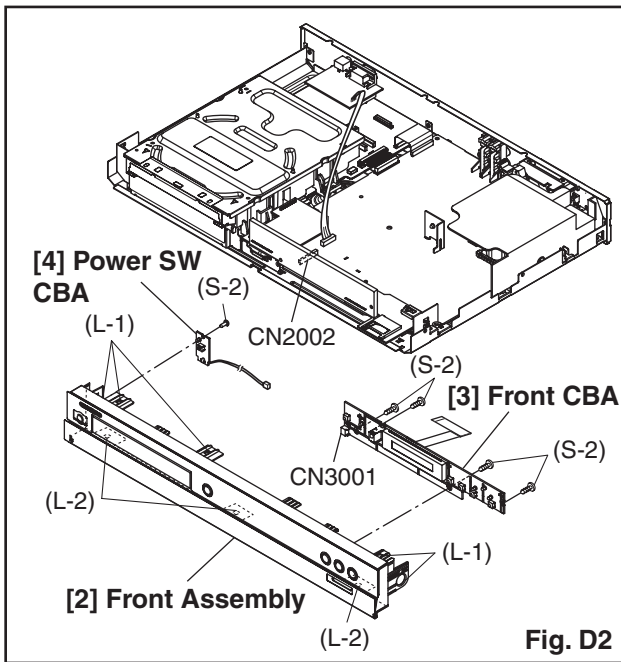
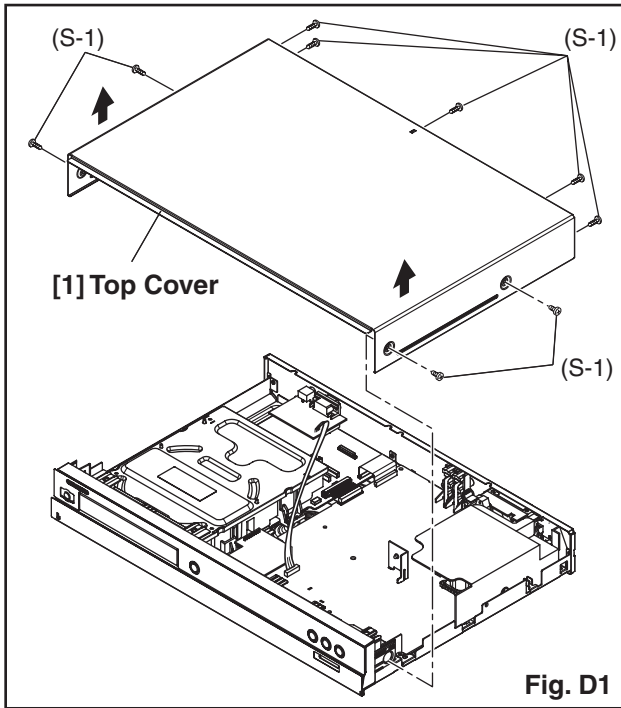

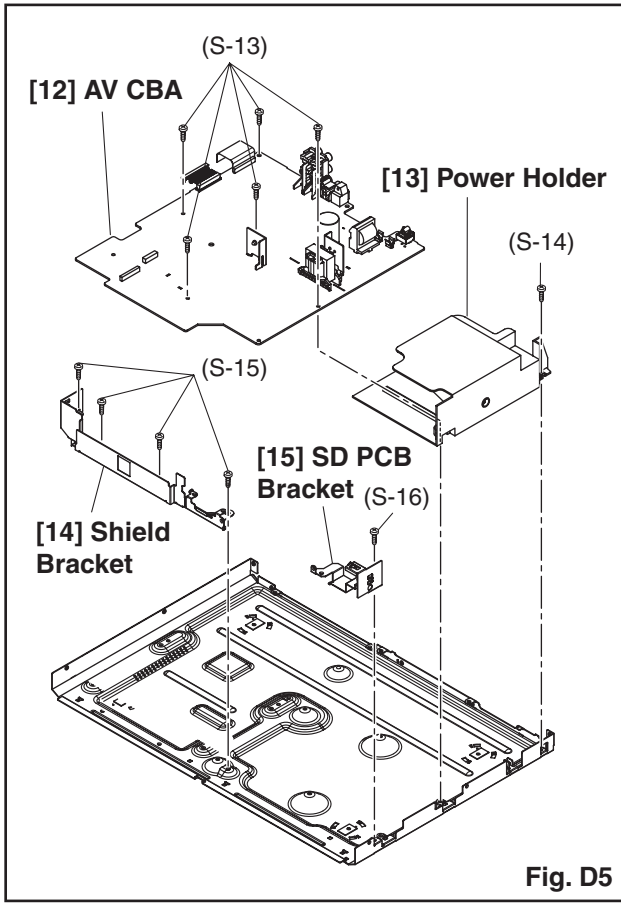
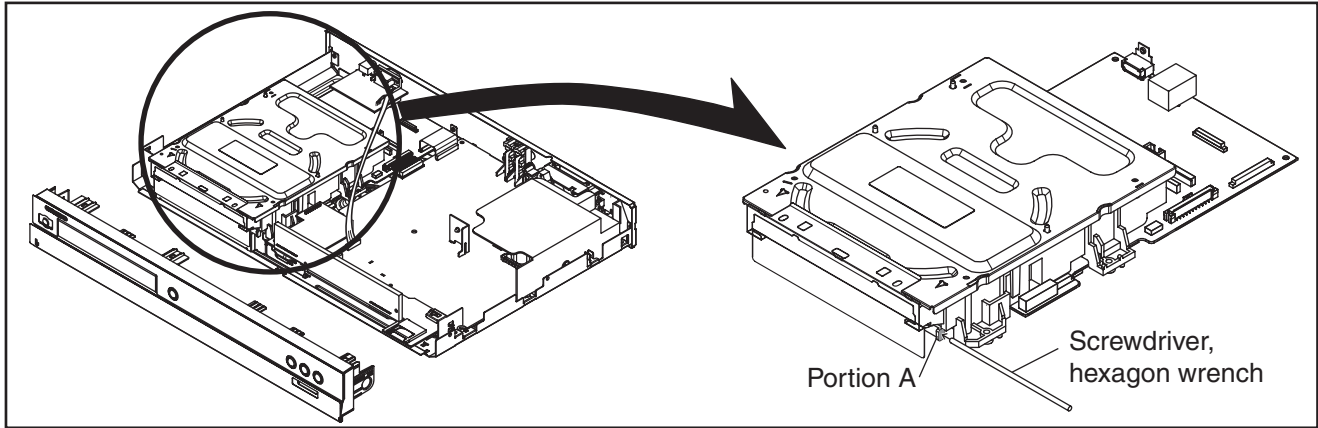

Fig. D5

3. How to Eject Manually

1. Remove the Top Cover.
2. Insert a screwdriver, etc. into the Hole A straightly so that the Portion A is pushed.
3. Pull the tray out manually and remove a disc.



HOW TO INITIALIZE THE BLU-RAY DISC PLAYER

To put the program back at the factory-default, initialize the BD player as the following procedure.

1. Turn the power on.
2. Remove the disc on the tray and close the tray.
3. Press [1], [2], [3], [4], and [DISPLAY] buttons on the remote control unit in that order.

Fig. a appears on the screen.

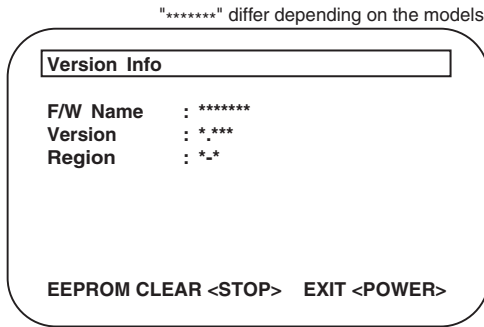

Fig. a

4. Press [■] button on the remote control unit.
Fig. b appears on the screen and Fig. c appears on the VFD.

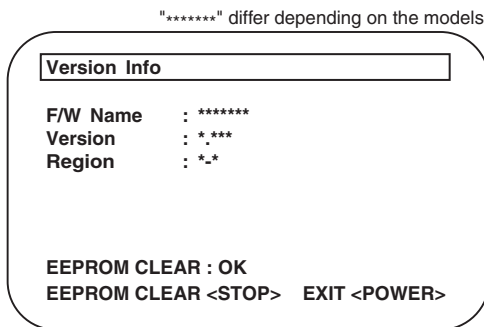

Fig. b

CLEAR

Fig. c

5. To exit this mode, press [ON/STANDBY] button.

FIRMWARE RENEWAL MODE

Note: The file extension of the available firmware is "b20".

1. Turn the power on and remove the disc on the tray and close the tray.
2. To put the BD player into version up mode, press [9], [8], [7], [6], and [POP UP MENU/MENU] buttons on the remote control unit in that order. The tray will open automatically. Fig. a appears on the screen and Fig. b appears on the VFD.

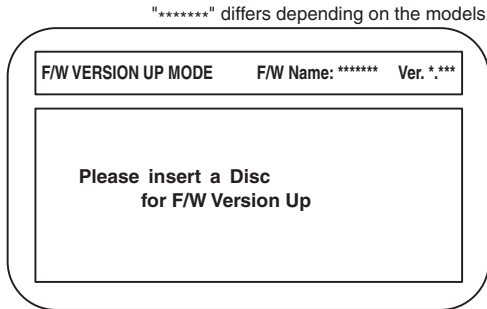

Fig. a Version Up Mode Screen



Fig. b VFD in Version Up Mode

3. Load the disc for version up.
4. The BD player enters the F/W version up mode automatically. Fig. c appears on the screen and Fig. d appears on the VFD. Make sure to insert the proper F/W for the state of this model.

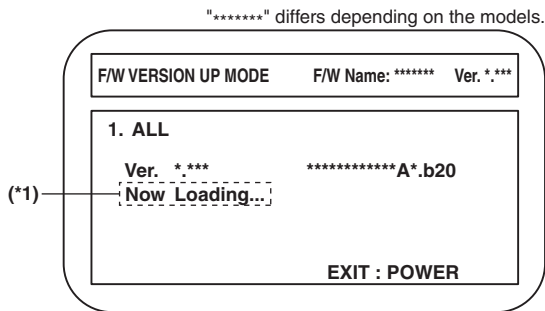

Fig. c Programming Mode Screen (Example)



Fig. d VFD in Programming Mode (Example)

The appearance shown in (*1) of Fig. c is described as follows:

| No. | Appearance | State |
|-----|----------------|--|
| 1 | Now Loading... | Loading the disc |
| 2 | Reading... | Sending files into the memory. After reading, automatically the tray opens. |
| 3 | See FL Display | Writing new version data, the progress will be displayed as shown in Fig. e. |



Fig. e VFD in Vresion Up Mode

5. After programming is finished, the checksum on the VFD (Fig. f).



Fig. f VFD upon Finishing the Programming Mode (Example)

Checksum appears on the VFD then the tray will open automatically. Remove the disc on the tray. At this time, no button is available.

6. Unplug the AC cord from the AC outlet. Then plug it again.
7. Turn the power on.
8. Press [1], [2], [3], [4], and [DISPLAY] buttons on the remote control unit in that order. Fig. g appears on the screen.

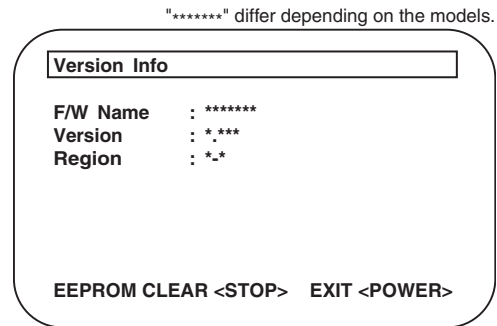

Fig. g

9. Press [■] button on the remote control unit. Fig. h appears on the screen and Fig. i appears on the VFD.

"*****" differ depending on the models.

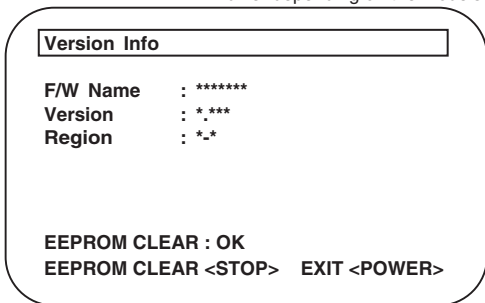

Fig. h

CLEAR

Fig. i

10. To exit this mode, press [ON/STANDBY] button.

How to Verify the Firmware Version

1. Turn the power on.
2. Remove the disc on the tray and close the tray.
3. Press [1], [2], [3], [4], and [DISPLAY] buttons on the remote control unit in that order. Fig. j appears on the screen.

"*****" differ depending on the models.

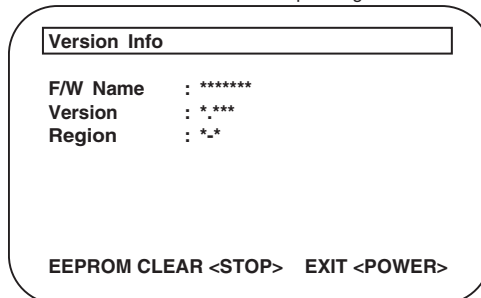
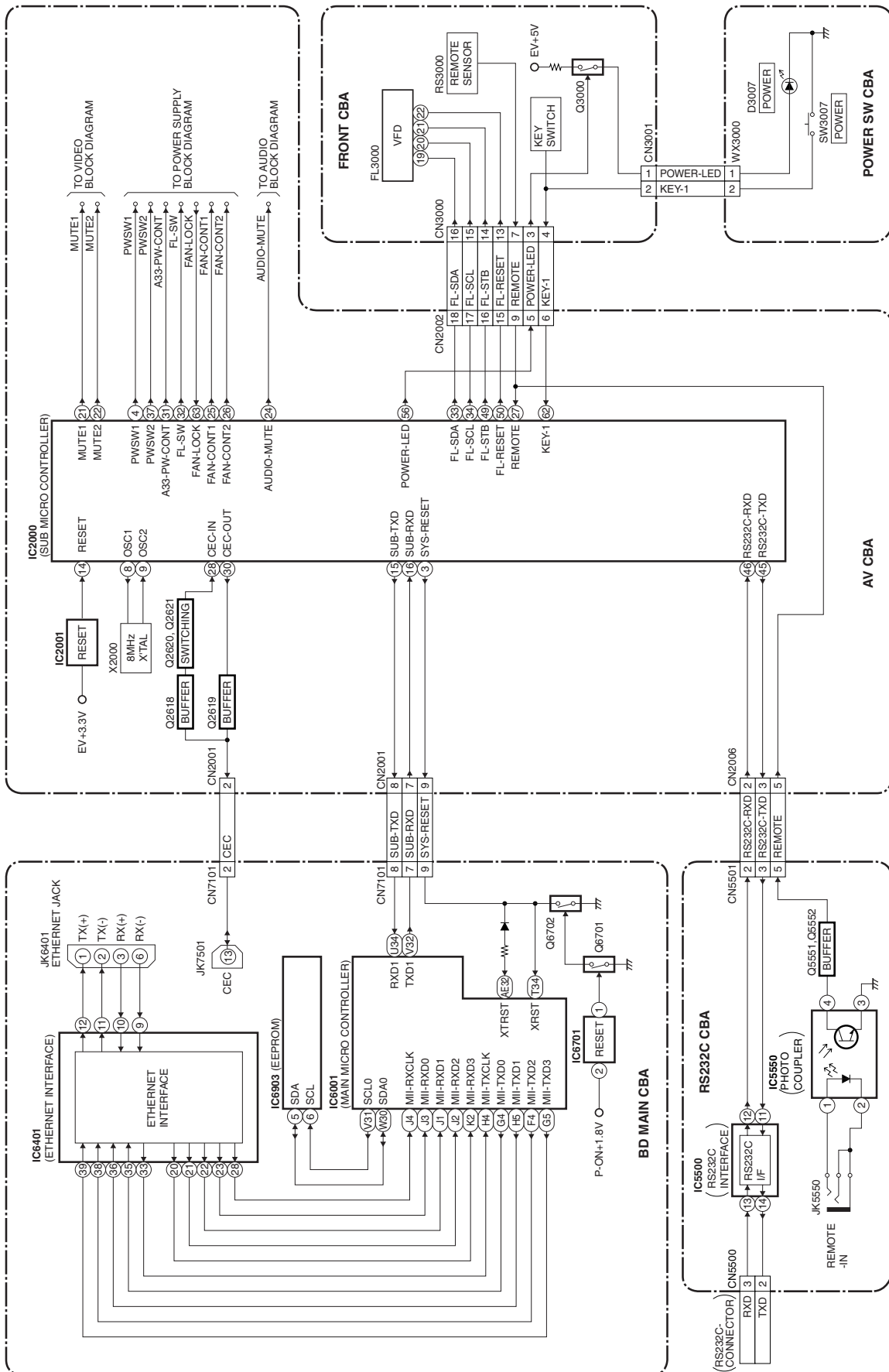

Fig. j

4. To exit this mode, press [ON/STANDBY] button.

BLOCK DIAGRAMS

System Control Block Diagram



Digital Signal Process 1 Block Diagram

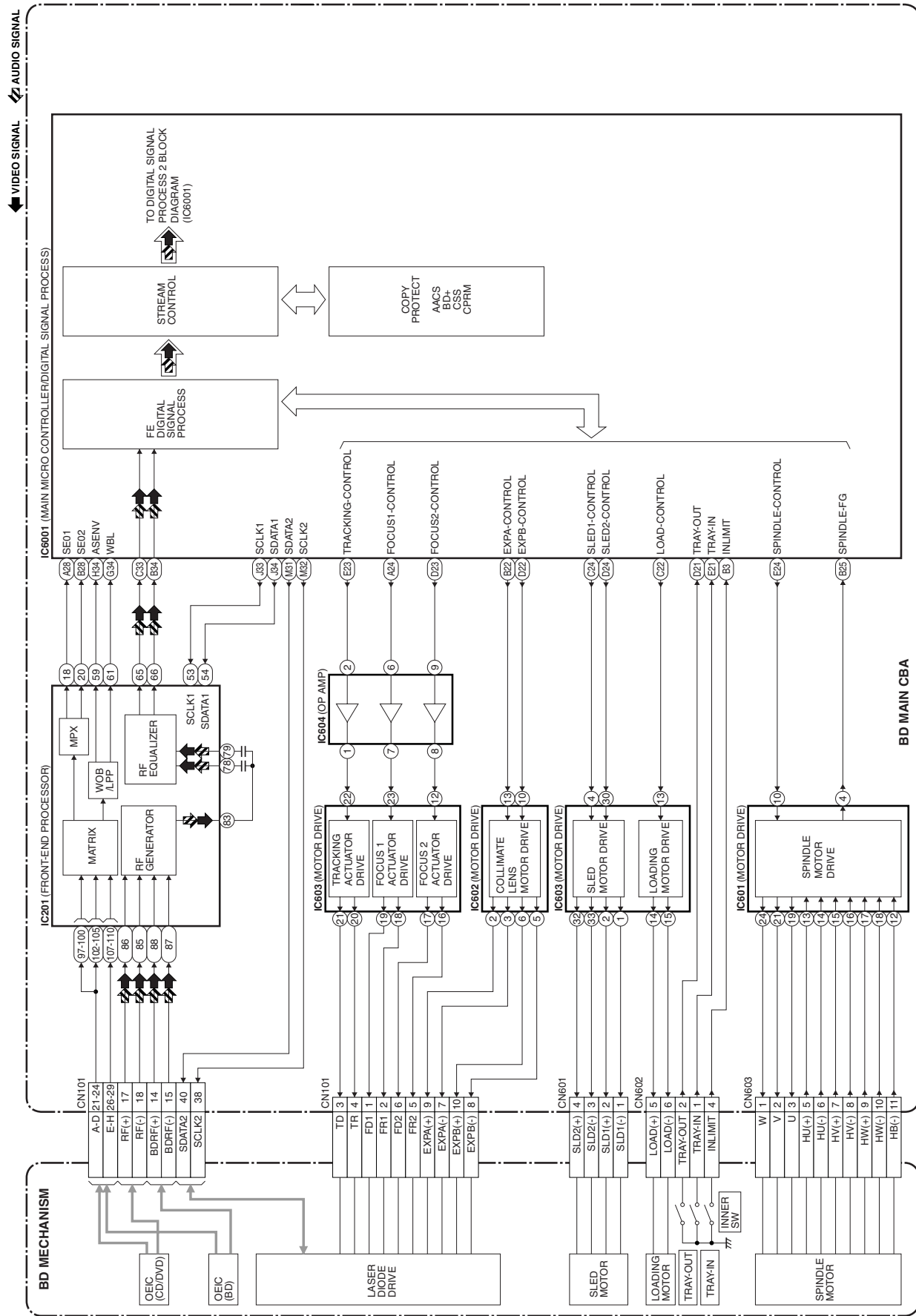

Digital Signal Process 2 Block Diagram

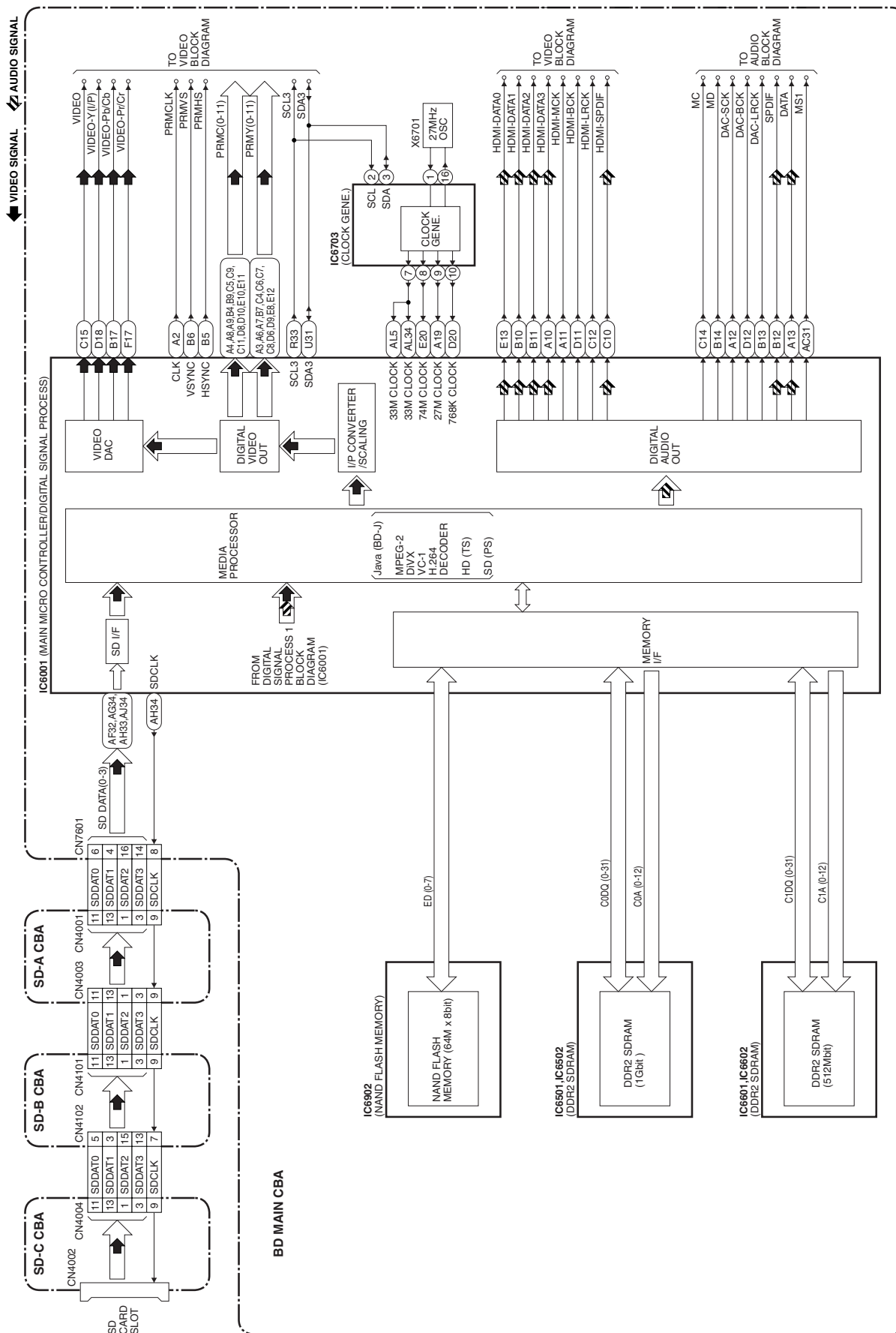

Video Block Diagram

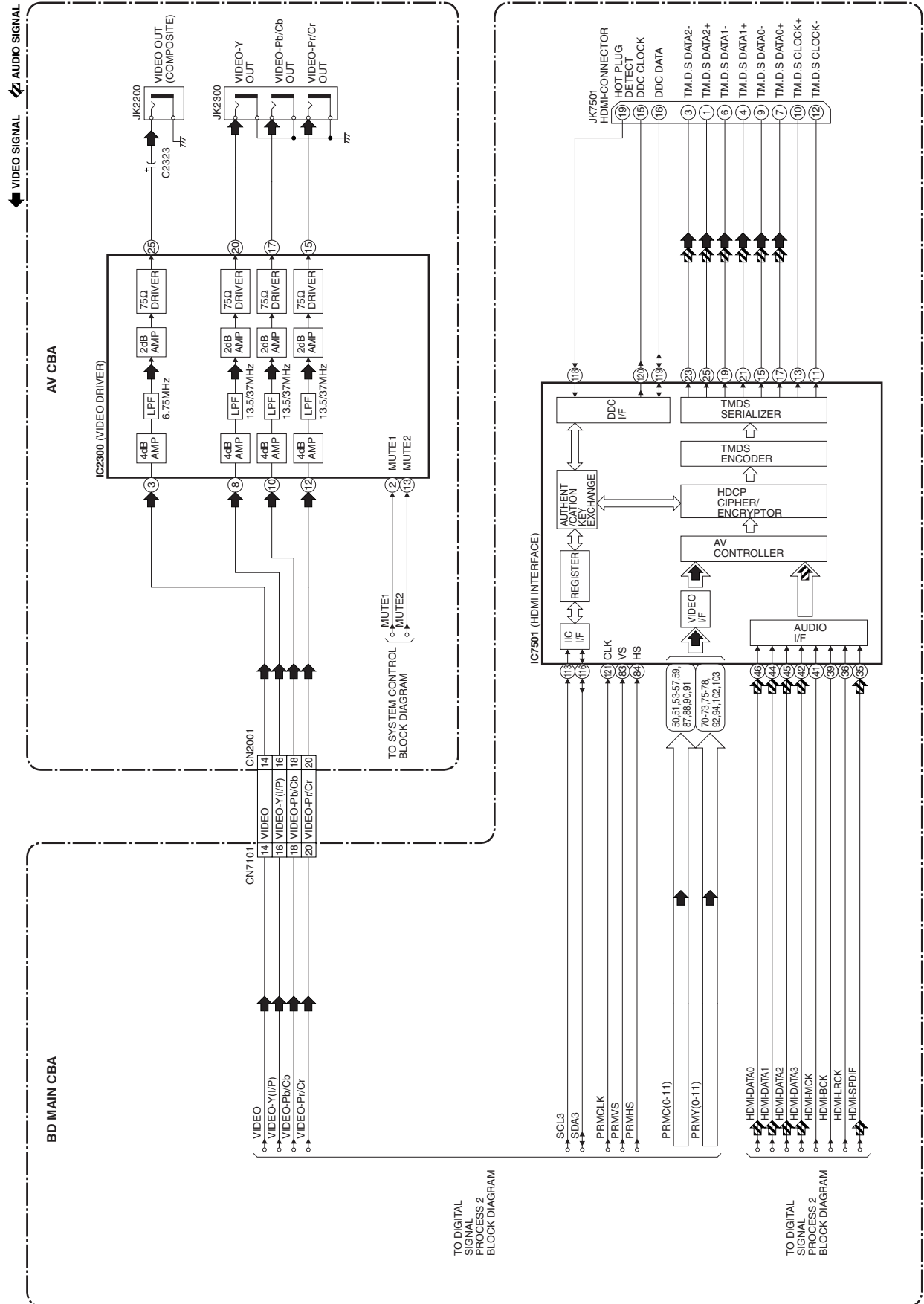

Audio Block Diagram

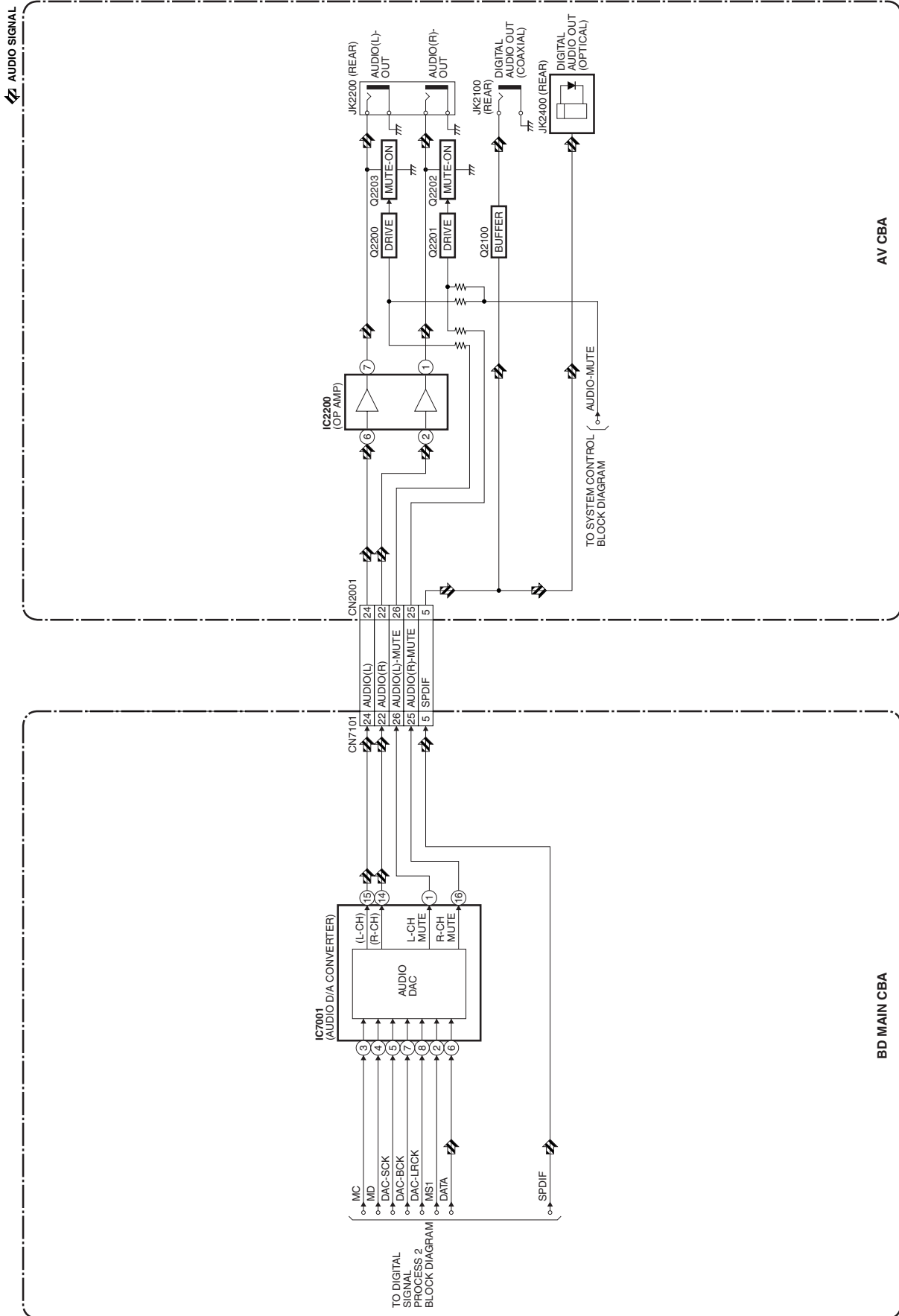

Power Supply Block Diagram

NOTE:
The voltage for parts in hot circuit is measured using hot GND as a common terminal.

CAUTION !
For continued protection against fire hazard, replace only with the same type fuse.
ATTENTION : Pour une protection continue les risques d'incendie n'utiliser que des fusibles de même type.
Risk of fire-replace fuse as marked.
This symbol means fast operating fuse.
Ce symbole représente un fusible à fusion rapide.



CAUTION !
Fixed voltage (or Auto voltage selectable) power supply circuit is used in this unit.
If Main Fuse (F1001) is blown, check to see that all components in the power supply circuit are not defective before you connect the AC plug to the AC power supply.
Otherwise it may cause some components in the power supply circuit to fail.

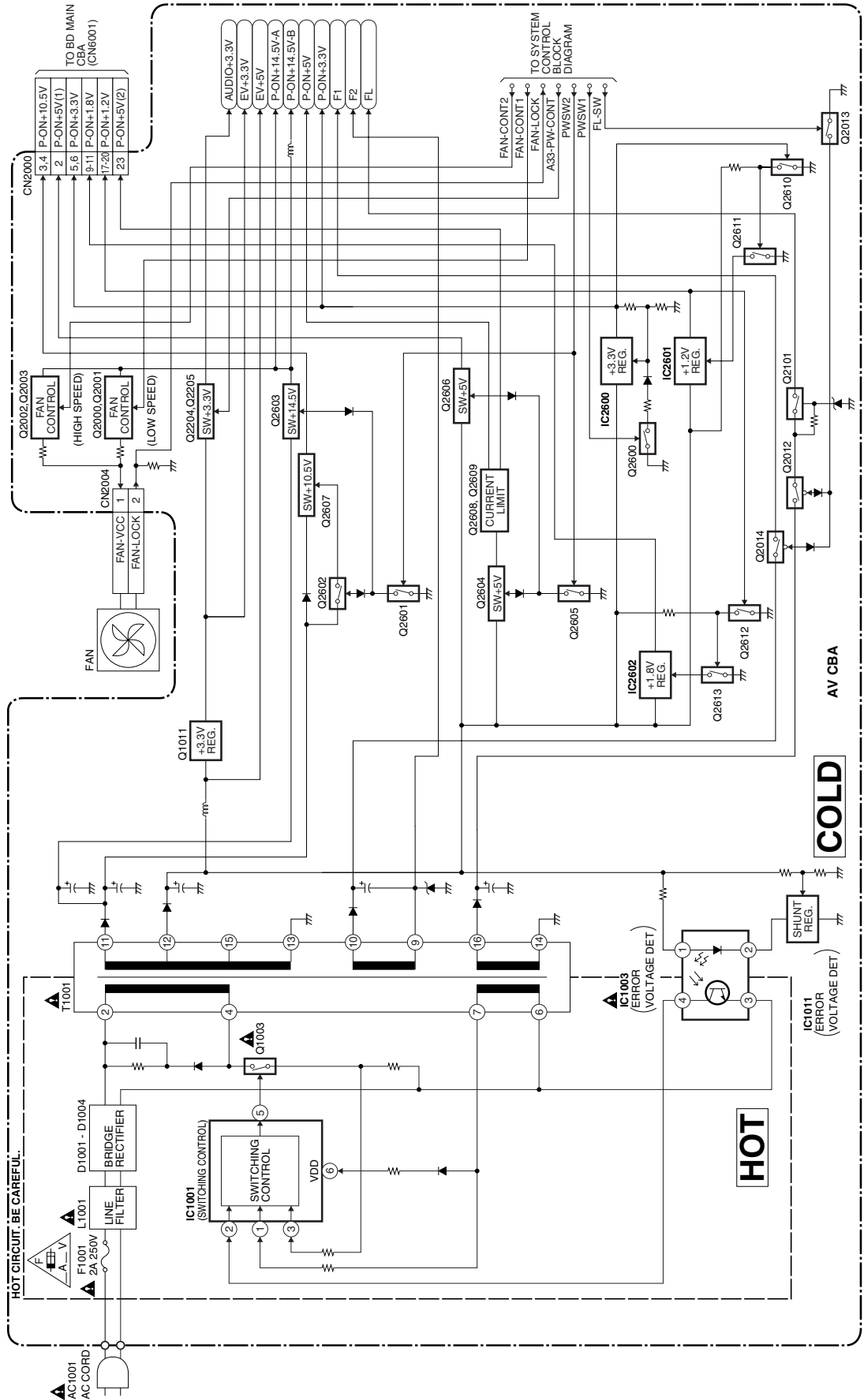

SCHEMATIC DIAGRAMS / CBA AND TEST POINTS

Standard Notes

WARNING

Many electrical and mechanical parts in this chassis have special characteristics. These characteristics often pass unnoticed and the protection afforded by them cannot necessarily be obtained by using replacement components rated for higher voltage, wattage, etc. Replacement parts that have these special safety characteristics are identified in this manual and its supplements; electrical components having such features are identified by the mark “▲” in the schematic diagram and the parts list. Before replacing any of these components, read the parts list in this manual carefully. The use of substitute replacement parts that do not have the same safety characteristics as specified in the parts list may create shock, fire, or other hazards.

Notes:

1. Do not use the part number shown on these drawings for ordering. The correct part number is shown in the parts list, and may be slightly different or amended since these drawings were prepared.
2. All resistance values are indicated in ohms (K = 10^3 , M = 10^6).
3. Resistor wattages are 1/4W or 1/6W unless otherwise specified.
4. All capacitance values are indicated in μF (P = 10^{-6} μF).
5. All voltages are DC voltages unless otherwise specified.

LIST OF CAUTION, NOTES, AND SYMBOLS USED IN THE SCHEMATIC DIAGRAMS ON THE FOLLOWING PAGES:

1. CAUTION:

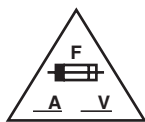

FOR CONTINUED PROTECTION AGAINST FIRE HAZARD, REPLACE ONLY WITH THE SAME TYPE FUSE.
 ATTENTION: POUR UNE PROTECTION CONTINUE LES RISQUES D'INCELE N'UTILISER QUE DES FUSIBLE DE MÊME TYPE.
 RISK OF FIRE-REPLACE FUSE AS MARKED.



This symbol means fast operating fuse.
 Ce symbole représente un fusible à fusion rapide.

2. CAUTION:

Fixed Voltage (or Auto voltage selectable) power supply circuit is used in this unit.
 If Main Fuse (F1001) is blown, first check to see that all components in the power supply circuit are not defective before you connect the AC plug to the AC power supply. Otherwise it may cause some components in the power supply circuit to fail.

3. Note:

- Do not use the part number shown on the drawings for ordering. The correct part number is shown in the parts list, and may be slightly different or amended since the drawings were prepared.
- To maintain original function and reliability of repaired units, use only original replacement parts which are listed with their part numbers in the parts list section of the service manual.

4. Voltage indications for PLAY and STOP mode on the schematics are as shown below:

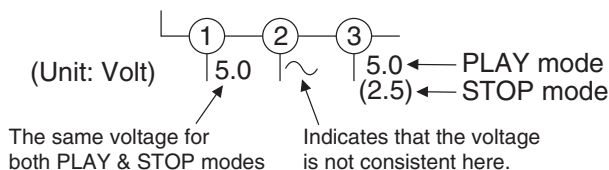

5. How to read converged lines

1-D3
 ↑ Distinction Area
 ↑ Line Number
 (1 to 3 digits)

Examples:

- "1-D3" means that line number "1" goes to the line number "1" of the area "D3".
- "1-B1" means that line number "1" goes to the line number "1" of the area "B1".

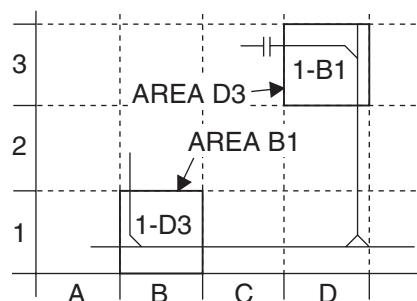

6. Test Point Information

- : Indicates a test point with a jumper wire across a hole in the PCB.
- : Used to indicate a test point with a component lead on foil side.
- : Used to indicate a test point with no test pin.
- : Used to indicate a test point with a test pin.

AV 1/3 Schematic Diagram

CAUTION !

Fixed voltage (or Auto voltage selectable) power supply circuit is used in this unit.
 If Main Fuse (F1001) is blown, check to see that all components in the power supply circuit are not defective before you connect the AC plug to the AC power supply.
 Otherwise it may cause some components in the power supply circuit to fail.

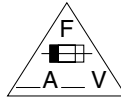

CAUTION !

For continued protection against fire hazard, replace only with the same type fuse.
ATTENTION : Pour une protection continue les risques d'Incele n'utiliser que des fusible de même type.
Risk of fire-replace fuse as marked.
 This symbol means fast operating fuse.
 "Ce symbole représente un fusible à fusion rapide."

NOTE:

The voltage for parts in hot circuit is measured using hot GND as a common terminal.

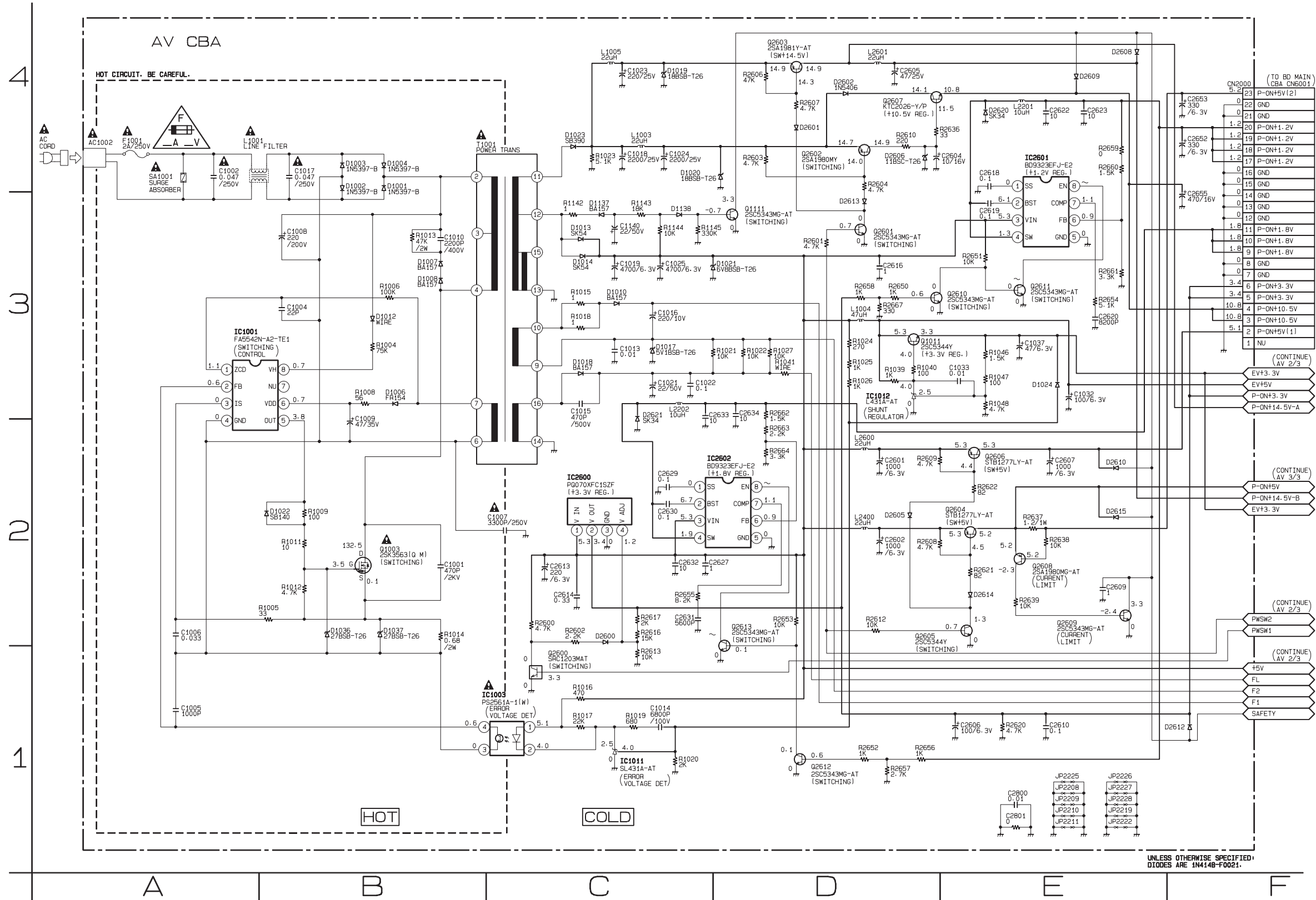

UNLESS OTHERWISE SPECIFIED, DIODES ARE 1N4148-F0021.

AV 2/3 Schematic Diagram

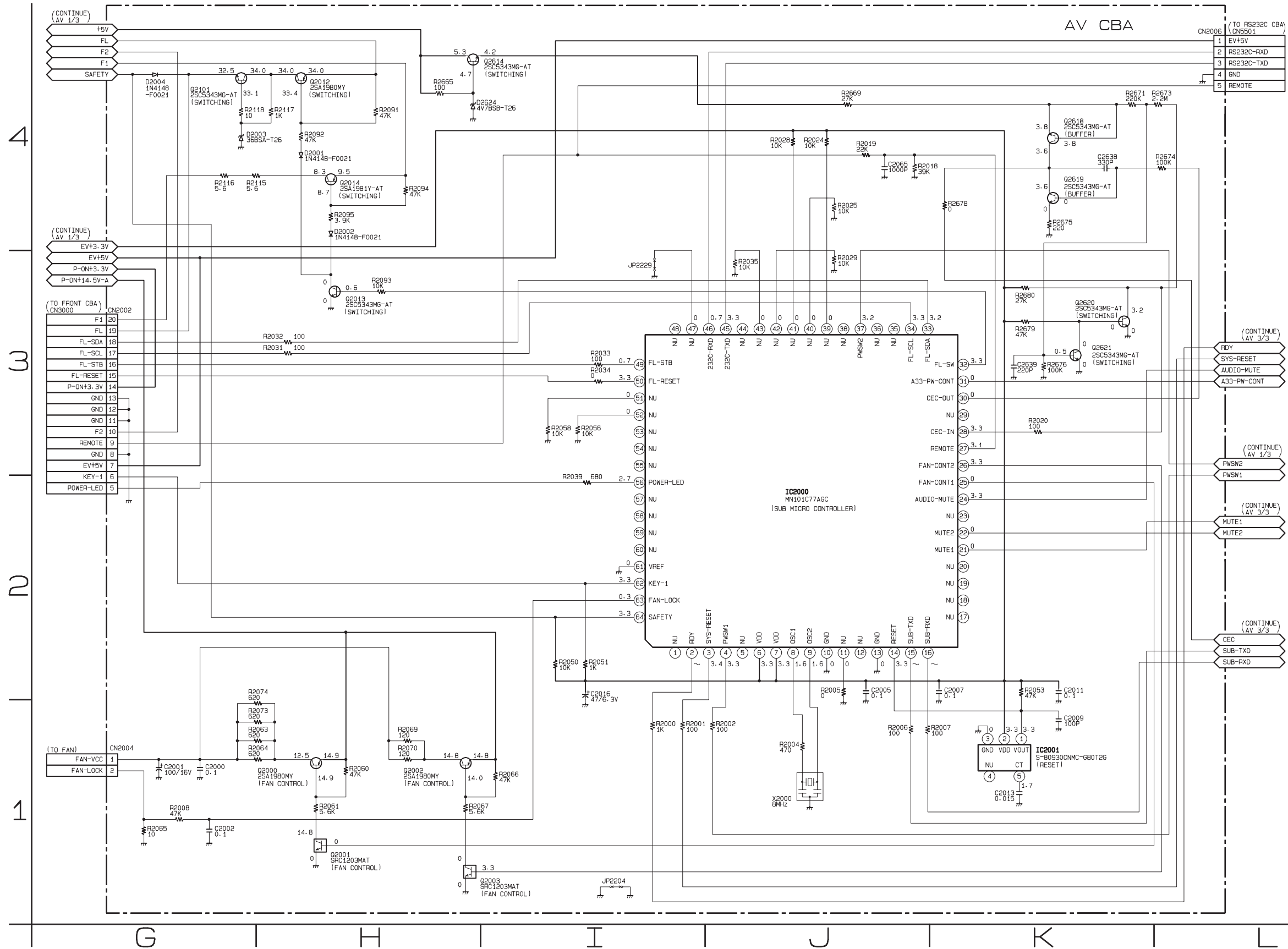

Front & Power SW Schematic Diagram

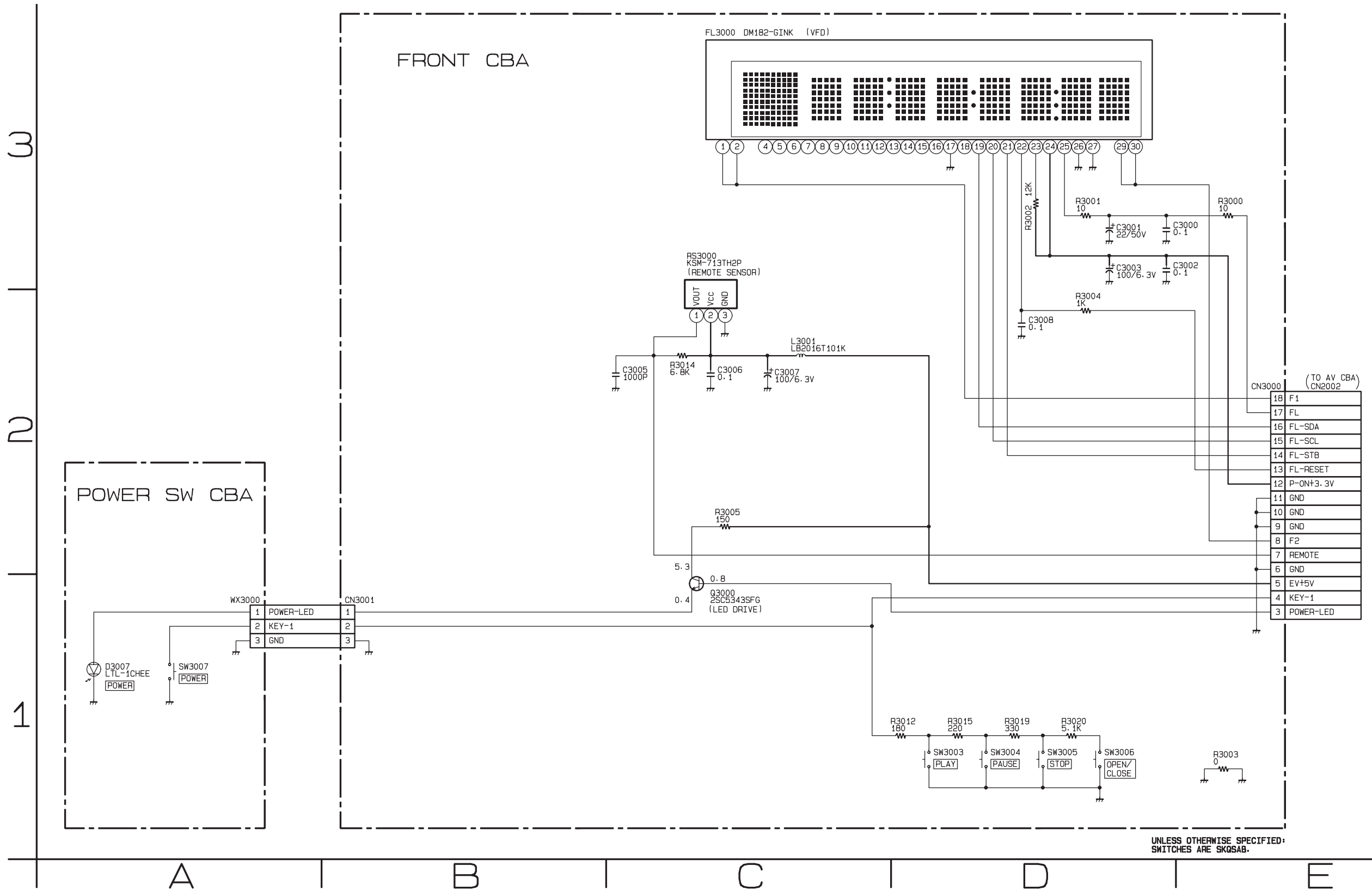

RS232C Schematic Diagram

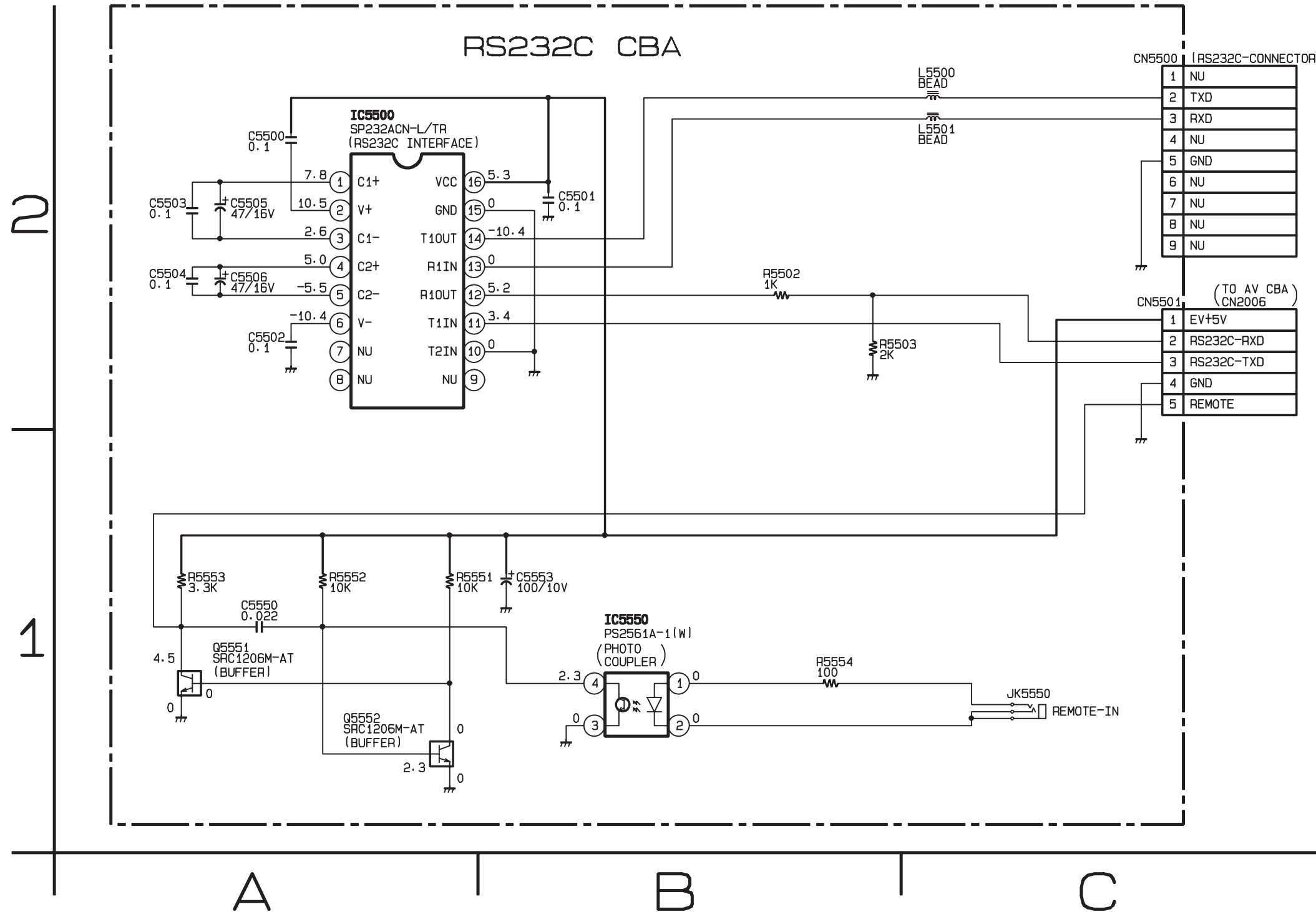

2

1

A

B

C

CN5500 (RS232C-CONNECTOR)

| | |
|---|-----|
| 1 | NU |
| 2 | TXD |
| 3 | RXD |
| 4 | NU |
| 5 | GND |
| 6 | NU |
| 7 | NU |
| 8 | NU |
| 9 | NU |

CN5501 (TO AV CBA CN2006)

| | |
|---|------------|
| 1 | EV+5V |
| 2 | RS232C-RXD |
| 3 | RS232C-TXD |
| 4 | GND |
| 5 | REMOTE |

SD-A, SD-B & SD-C Schematic Diagram

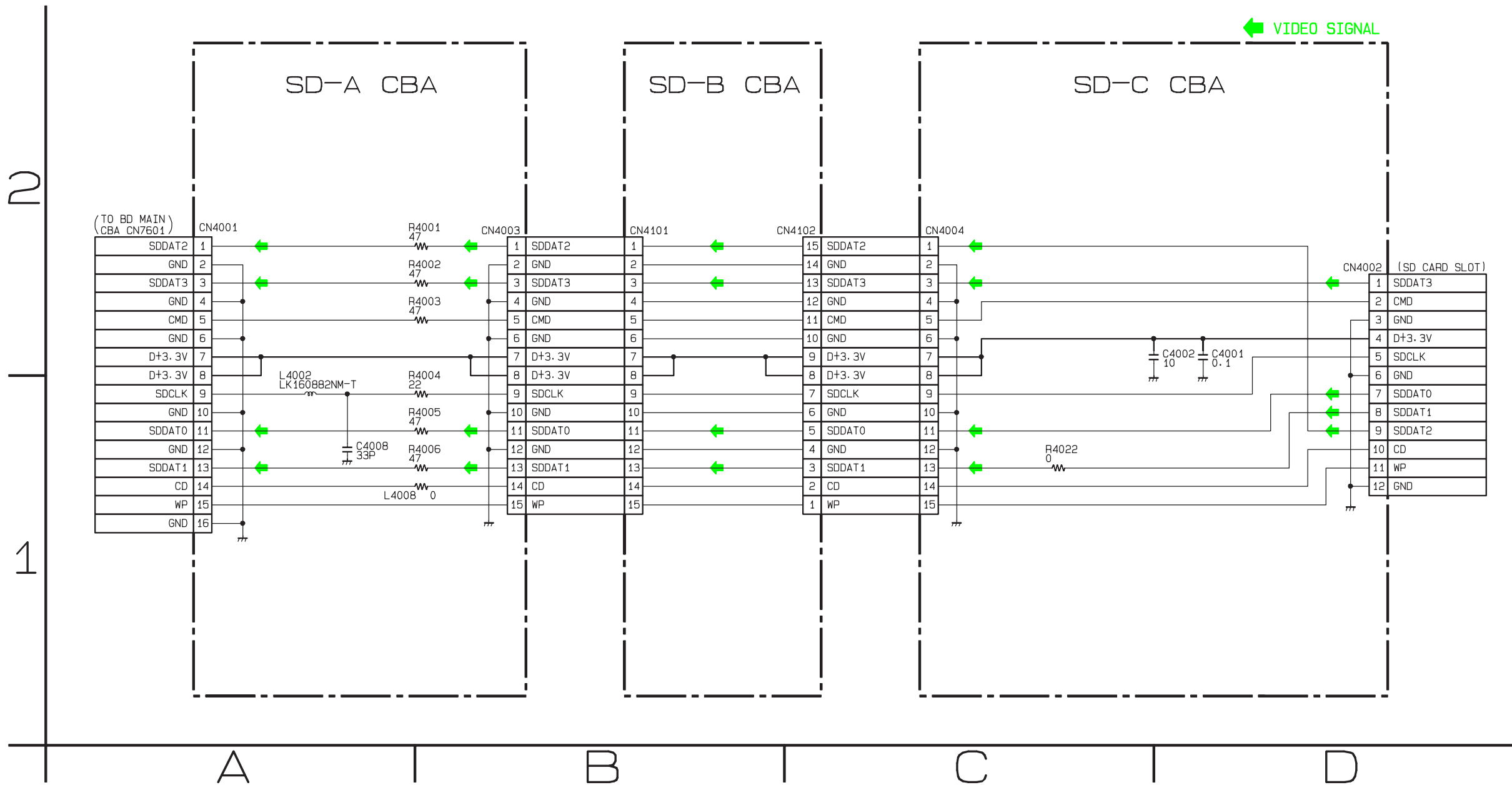

BD Main 1/11 Schematic Diagram

*1 NOTE:

The order of pins shown in this diagram is different from that of actual IC6001.
 IC6001 is divided into nine and shown as IC6001 (1/9) ~ IC6001 (9/9) in this BD Main Schematic Diagram Section.

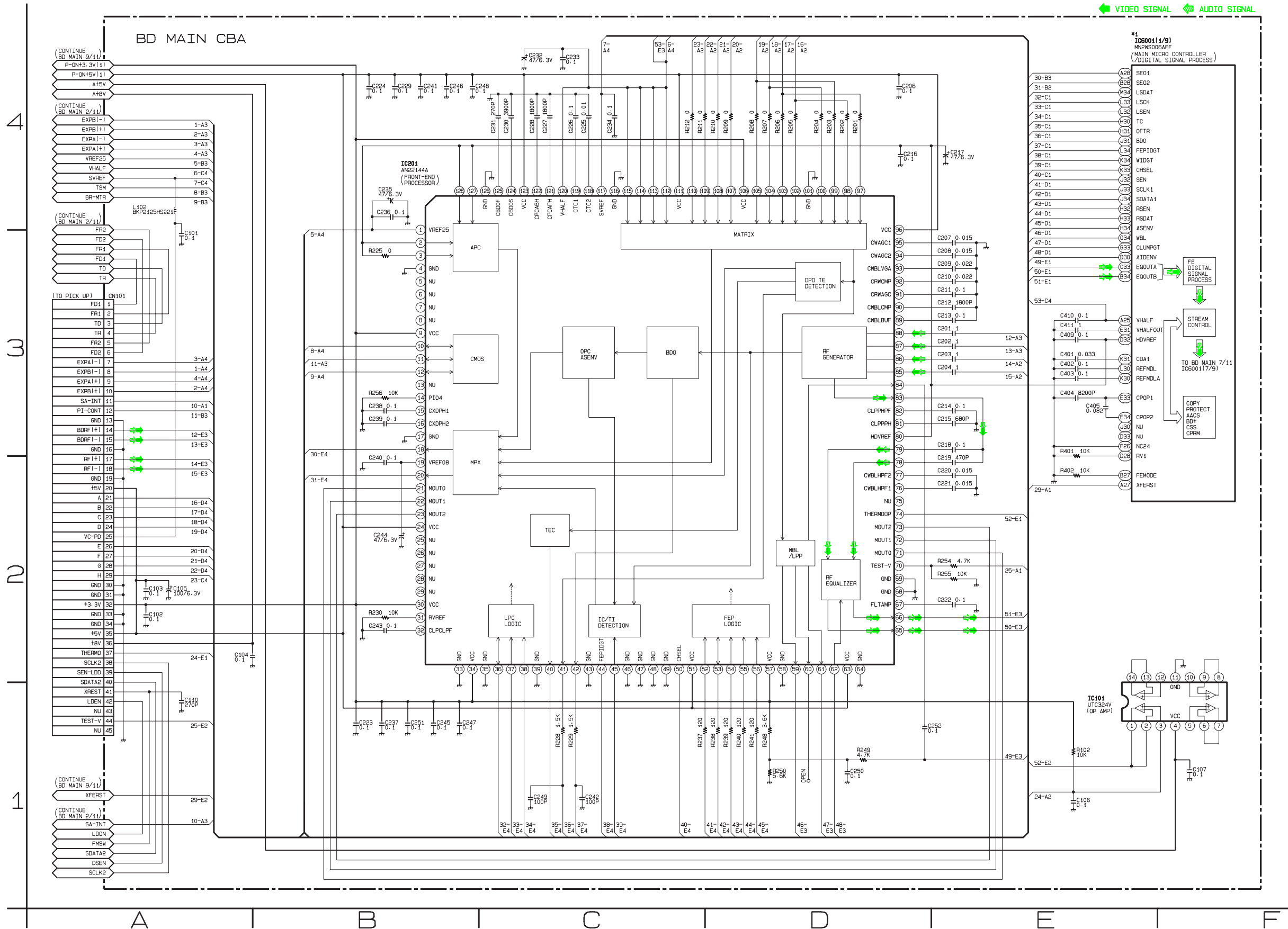

BD Main 2/11 Schematic Diagram

***1 NOTE:**

The order of pins shown in this diagram is different from that of actual IC6001.
 IC6001 is divided into nine and shown as IC6001 (1/9) ~ IC6001 (9/9) in this BD Main Schematic Diagram Section.

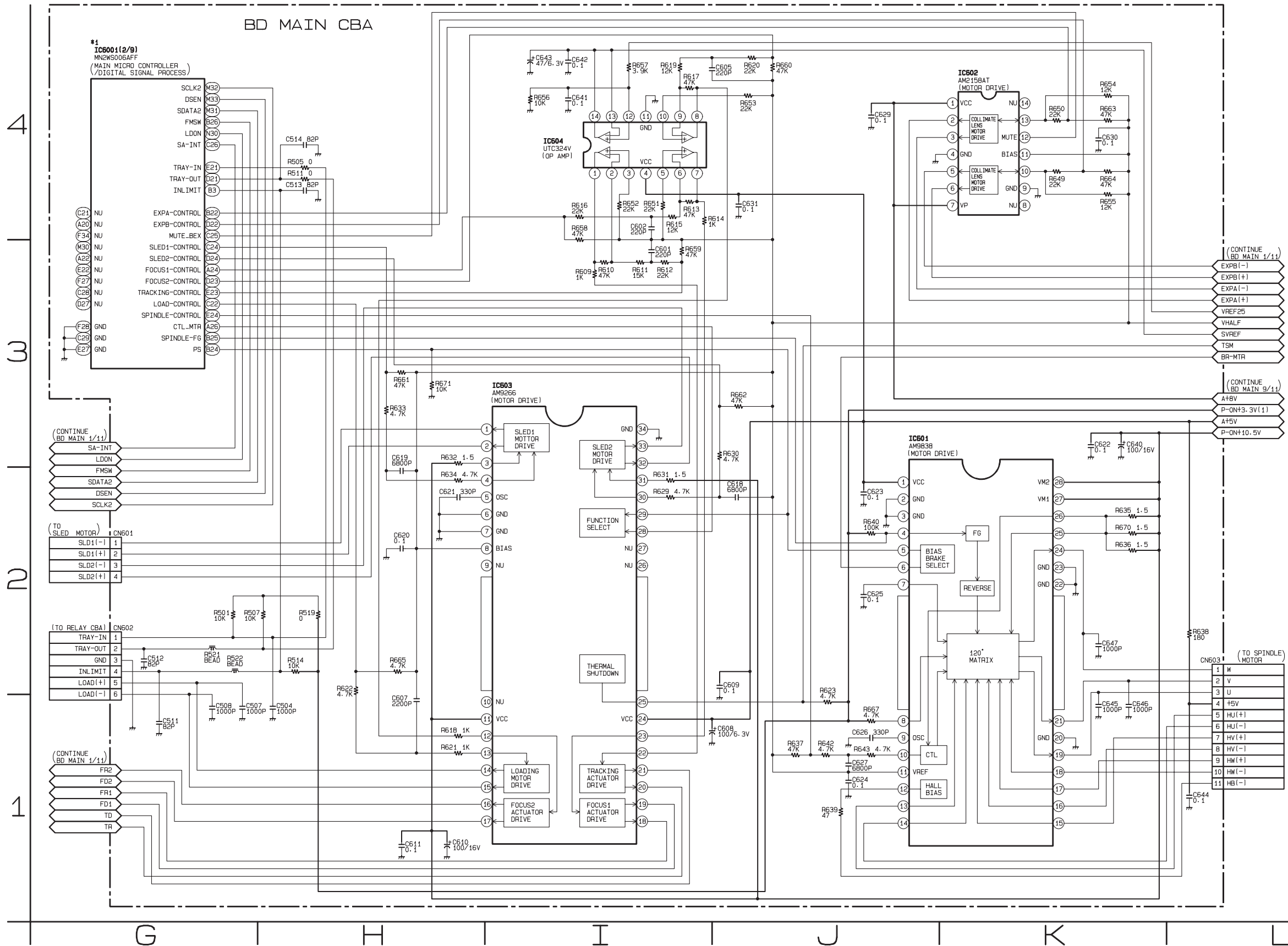

BD Main 5/11 Schematic Diagram

*1 NOTE:

The order of pins shown in this diagram is different from that of actual IC6001.
IC6001 is divided into nine and shown as IC6001 (1/9) ~ IC6001 (9/9) in this BD Main Schematic Diagram Section.

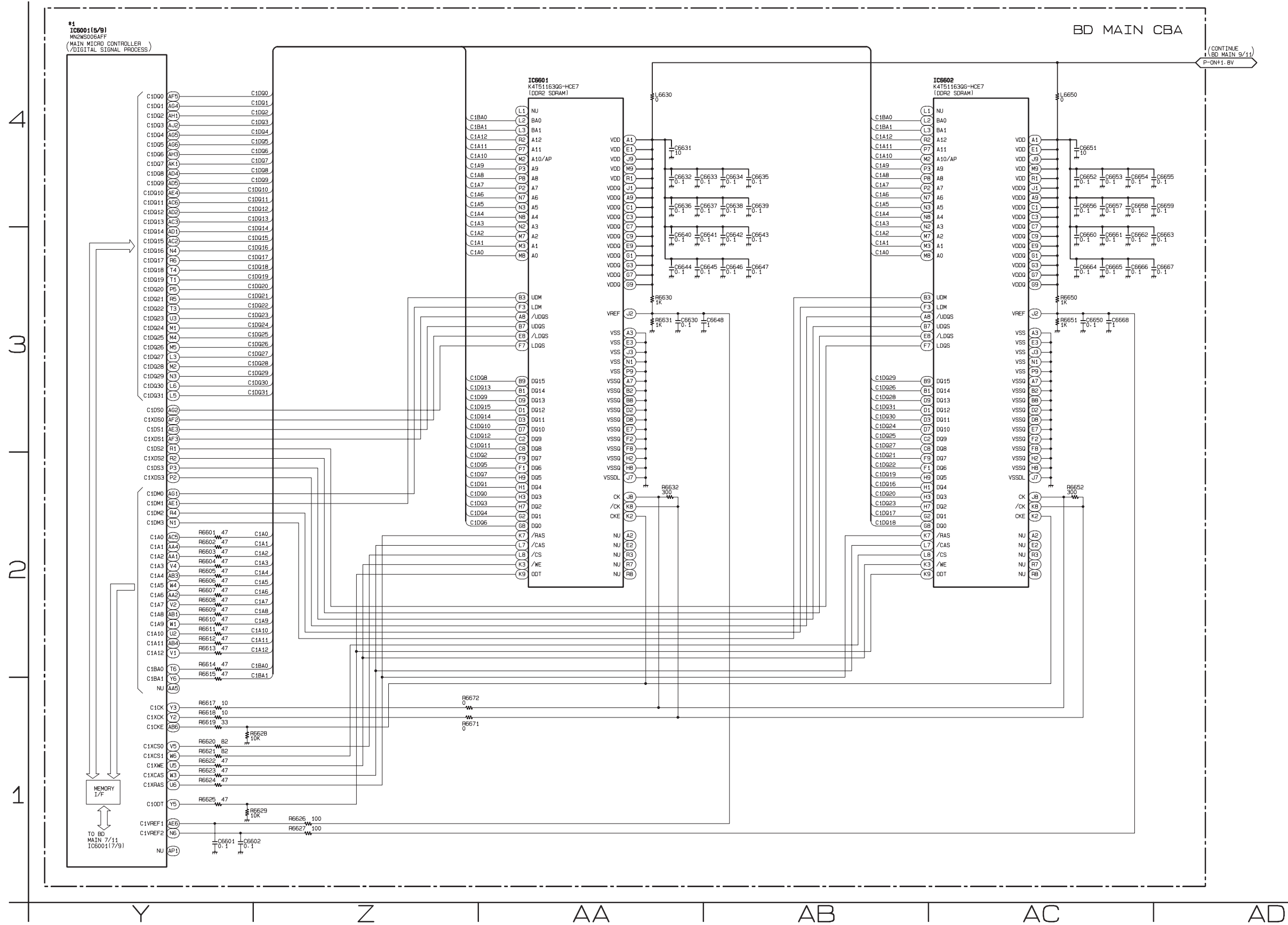

BD Main 6/11 Schematic Diagram

***1 NOTE:**

The order of pins shown in this diagram is different from that of actual IC6001.
 IC6001 is divided into nine and shown as IC6001 (1/9) ~ IC6001 (9/9) in this BD Main Schematic Diagram Section.

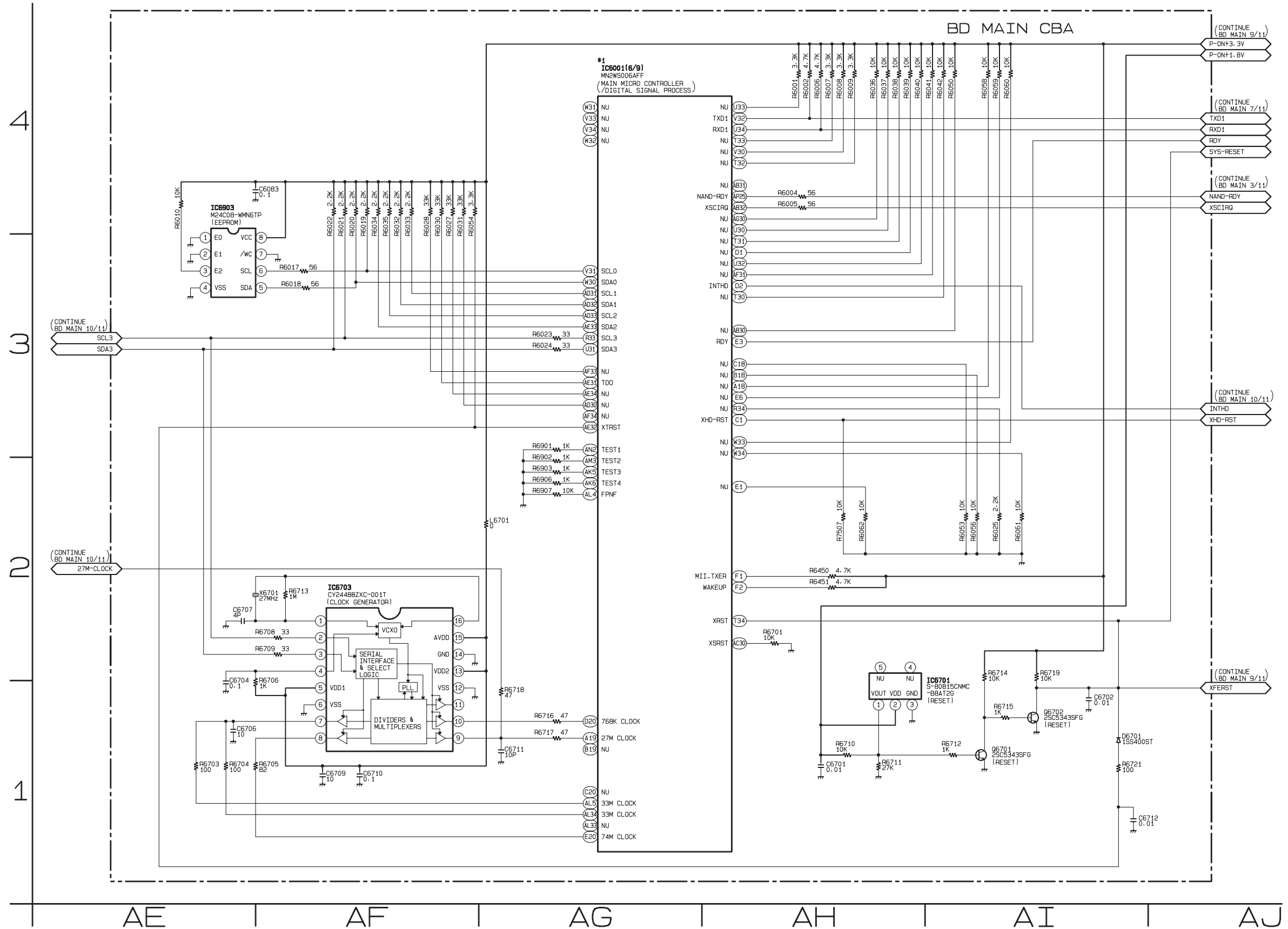

BD Main 7/11 Schematic Diagram

***1 NOTE:**

The order of pins shown in this diagram is different from that of actual IC6001.
 IC6001 is divided into nine and shown as IC6001 (1/9) ~ IC6001 (9/9) in this BD Main Schematic Diagram Section.

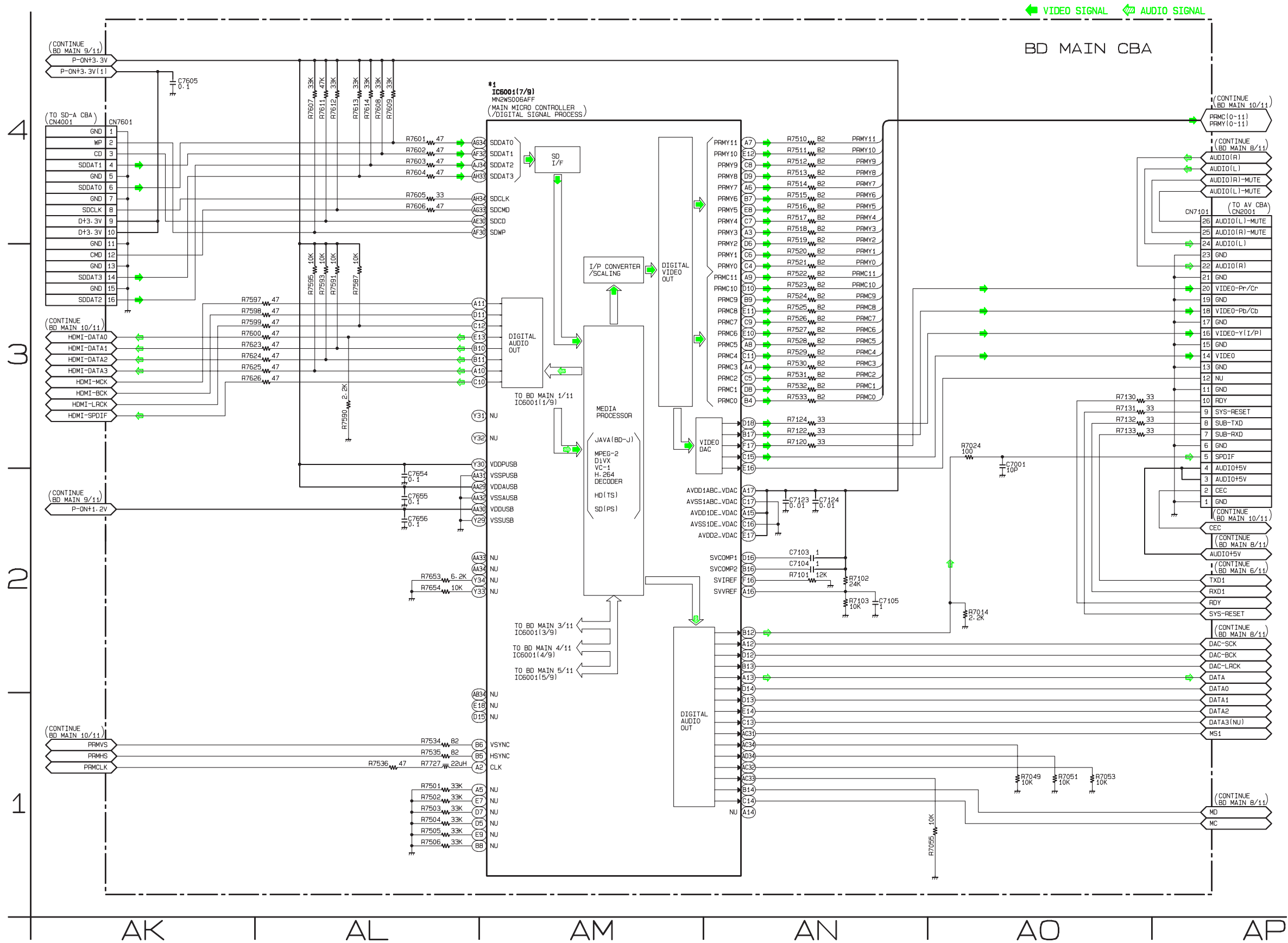

BD Main 8/11 Schematic Diagram

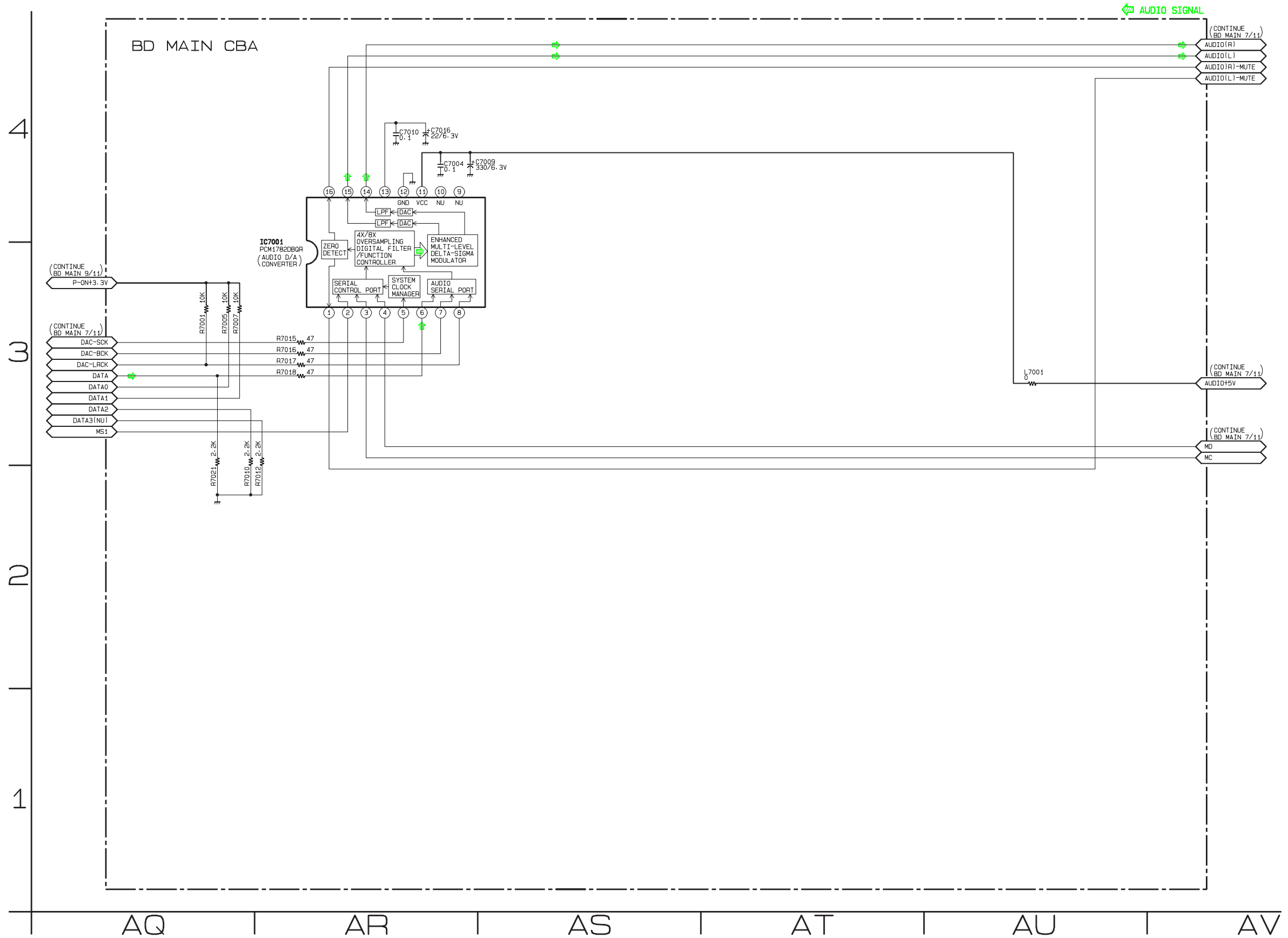

BD Main 9/11 Schematic Diagram

***1 NOTE:**
 The order of pins shown in this diagram is different from that of actual IC6001.
 IC6001 is divided into nine and shown as IC6001 (1/9) ~ IC6001 (9/9) in this BD Main Schematic Diagram Section.

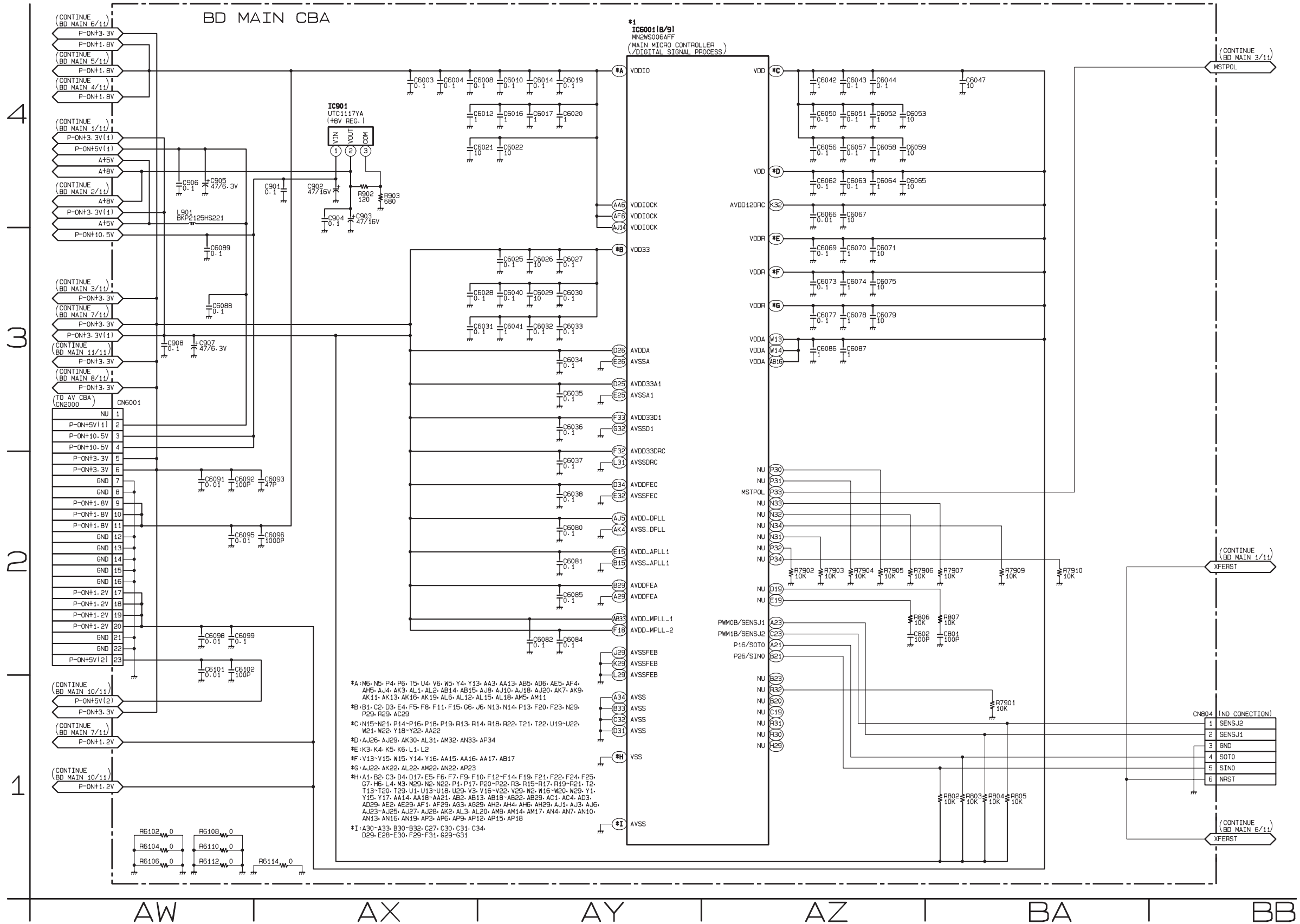

- *A: M6, N5, P4, P6, T5, U4, V6, W5, Y4, Y13, AA3, AA13, AB5, AD6, AE5, AF4, AH5, AJ4, AK3, AL1, AL2, AB14, AB15, AJ8, AJ10, AJ18, AJ20, AK7, AK9, AK11, AK13, AK16, AK19, AL6, AL12, AL15, AL18, AM5, AM11
- *B: B1, C2, D3, E4, F5, F8, F11, F15, G6, J6, N13, N14, P13, F20, F23, N29, P29, R29, AC29
- *C: N15, N21, P14, P16, P18, P19, R13, R14, R18, R22, T21, T22, U19, U22, W21, W22, Y18, Y22, AA22
- *D: AJ26, AJ29, AK30, AL31, AM32, AN33, AP34
- *E: K3, K4, K5, K6, L1, L2
- *F: V13, V15, W15, Y14, Y16, AA15, AA16, AA17, AB17
- *G: AJ22, AK22, AL22, AM22, AN22, AP23
- *H: A1, B2, C3, D4, D17, E5, F6, F7, F9, F10, F12, F14, F19, F21, F22, F24, F25, G7, H6, L4, M3, M29, N2, N22, P1, P17, P20, P22, R3, R15, R17, R19, R24, T2, T13, T20, T29, U1, U13, U18, U29, V3, V16, V22, V29, W2, W16, W20, W29, Y1, Y15, Y17, AA14, AA18, AA21, AB2, AB13, AB18, AB22, AB29, AC1, AC4, AD3, AD29, AE2, AE29, AF1, AF29, AG3, AG29, AH2, AH4, AH6, AH29, AJ1, AJ3, AJ6, AJ23, AJ25, AJ27, AJ28, AK2, AL3, AL20, AM6, AM14, AM17, AN4, AN7, AN10, AN13, AN16, AN19, AP3, AP6, AP9, AP12, AP15, AP18
- *I: A30, A33, B30, B32, C27, C30, C31, C34, D29, E28, E30, F29, F31, G29, G31

BD Main 10/11 Schematic Diagram

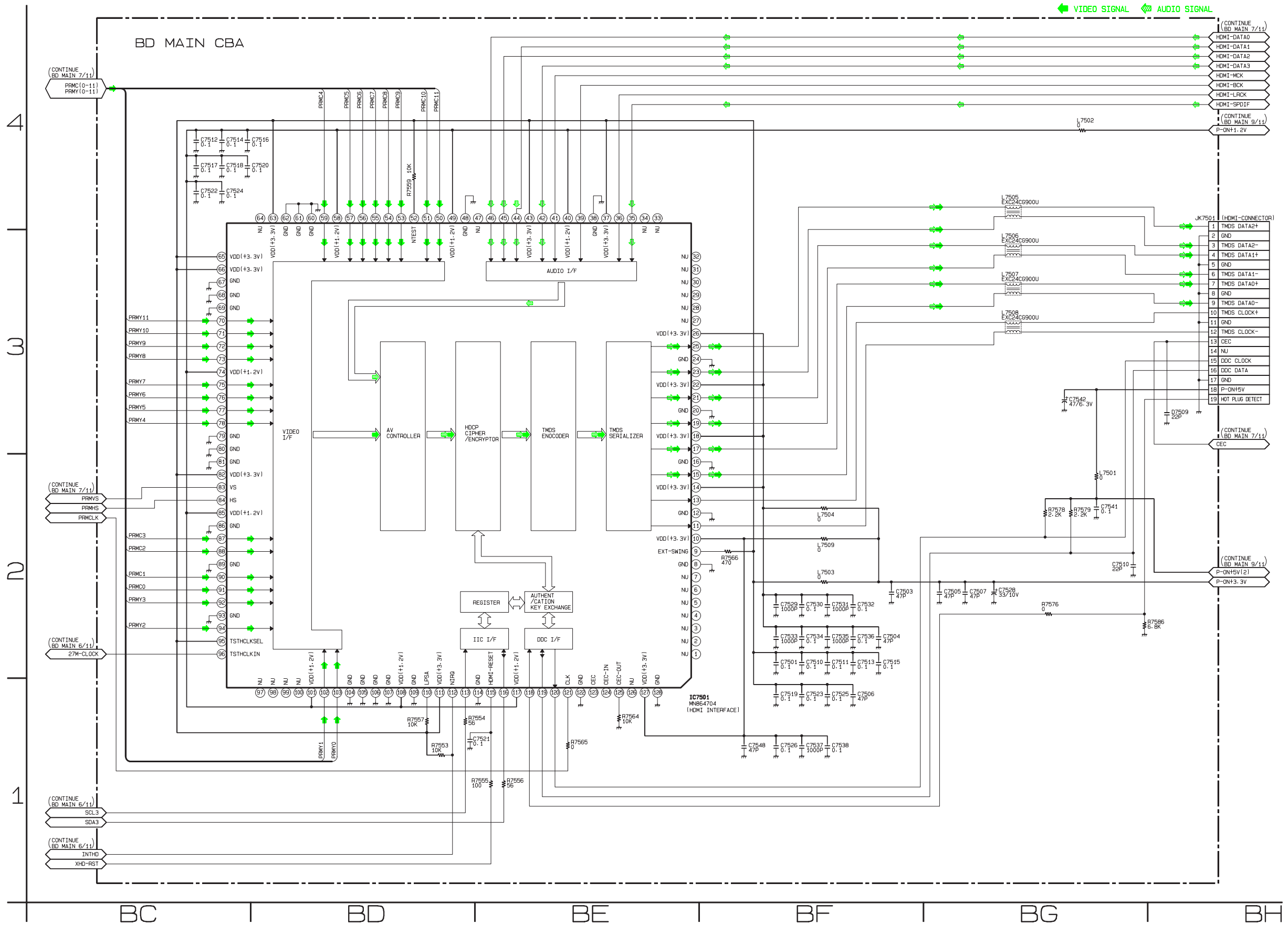

BD Main 11/11 Schematic Diagram

***1 NOTE:**

The order of pins shown in this diagram is different from that of actual IC6001.
 IC6001 is divided into nine and shown as IC6001 (1/9) ~ IC6001 (9/9) in this BD Main Schematic Diagram Section.

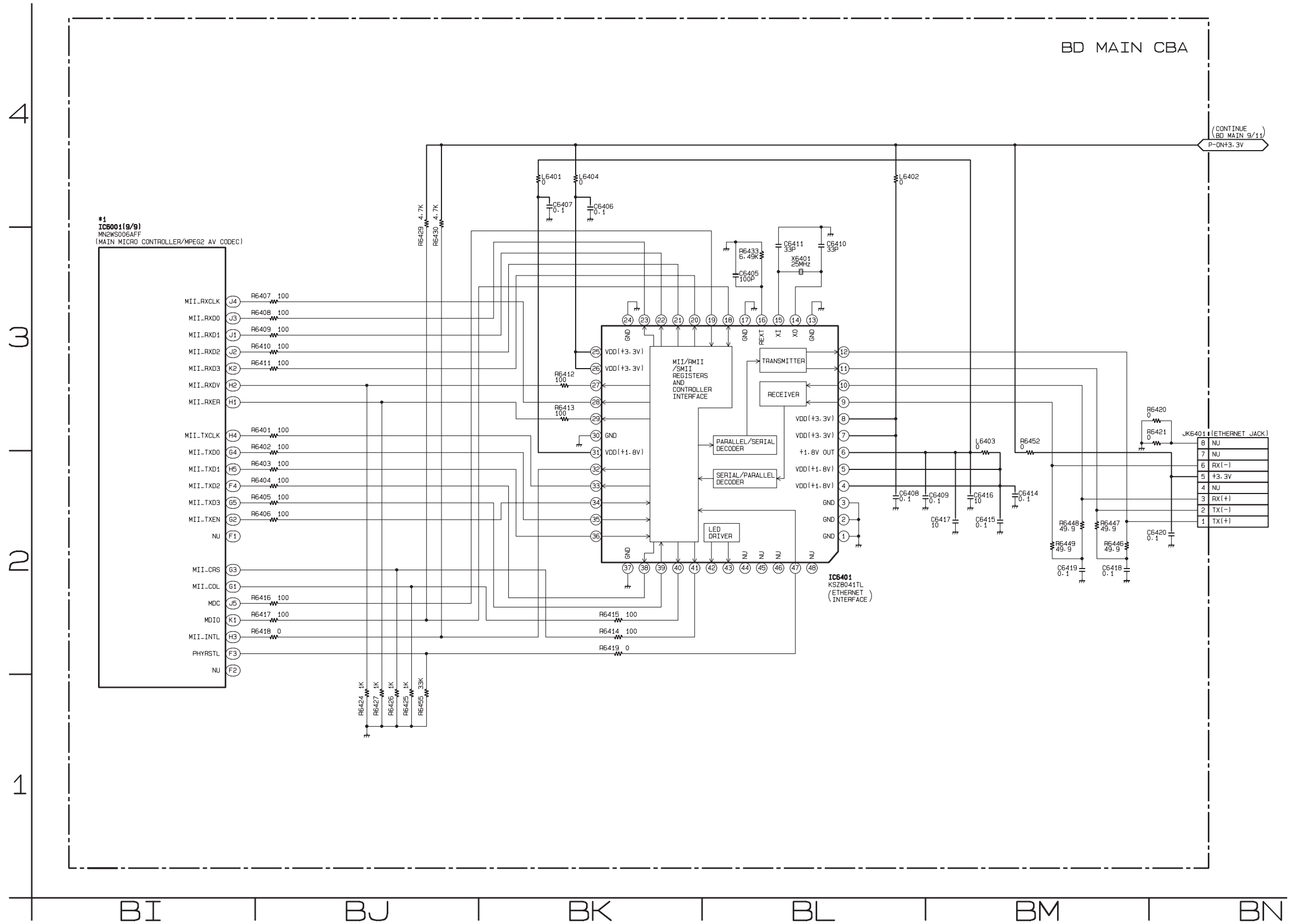

AV CBA Top View

CAUTION !

Fixed voltage (or Auto voltage selectable) power supply circuit is used in this unit.
If Main Fuse (F1001) is blown, check to see that all components in the power supply circuit are not defective before you connect the AC plug to the AC power supply.
Otherwise it may cause some components in the power supply circuit to fail.

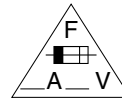

CAUTION !

For continued protection against fire hazard, replace only with the same type fuse.
ATTENTION : Pour une protection continue les risques d'Incele n'utiliser que des fusible de même type.
Risk of fire-replace fuse as marked.

■ This symbol means fast operating fuse.
"Ce symbole représente un fusible à fusion rapide."

Because a hot chassis ground is present in the power supply circuit, an isolation transformer must be used.
Also, in order to have the ability to increase the input slowly, when troubleshooting this type power supply circuit, a variable isolation transformer is required.

NOTE:

The voltage for parts in hot circuit is measured using hot GND as a common terminal.

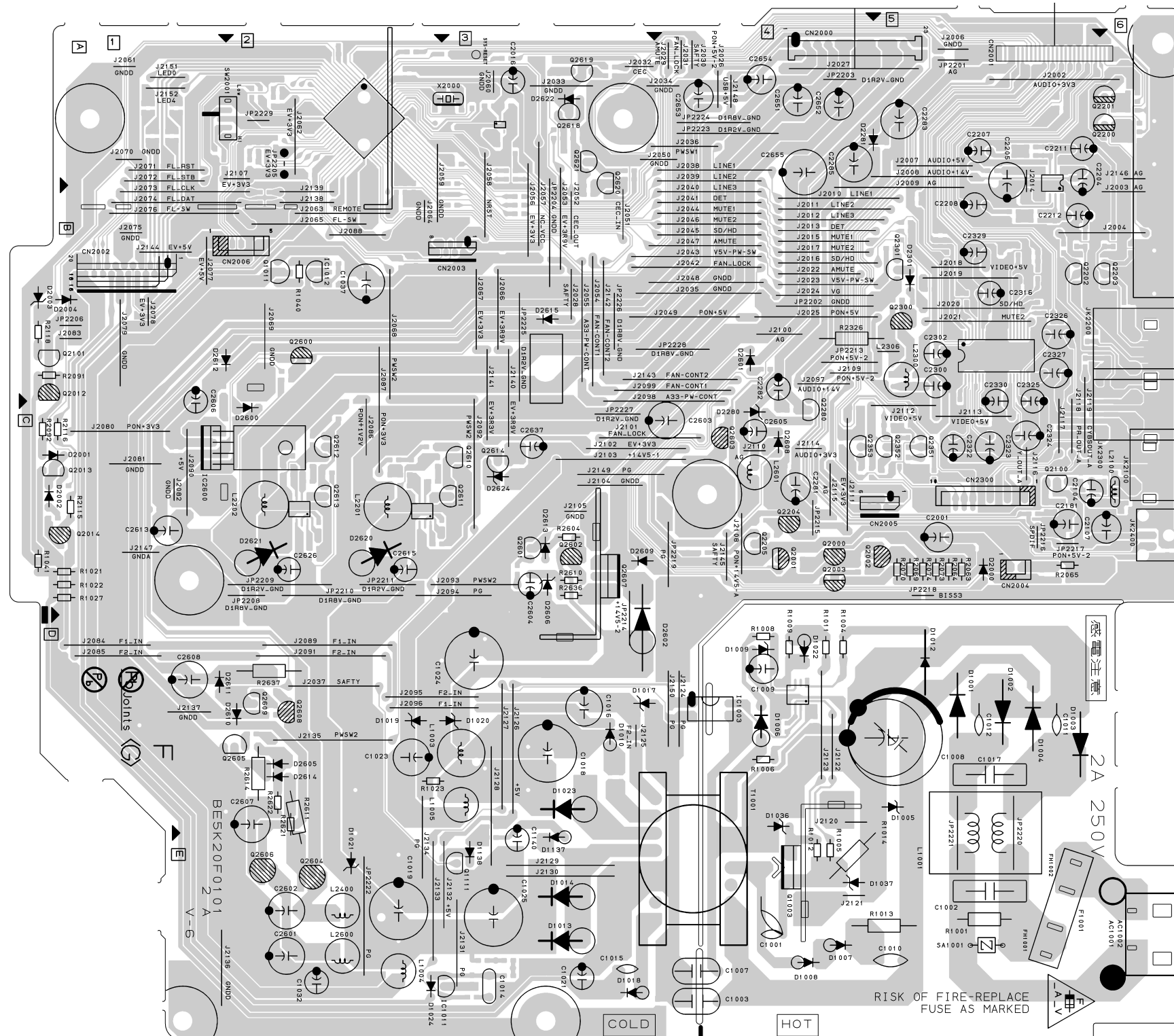

AV CBA Bottom View

CAUTION !

Fixed voltage (or Auto voltage selectable) power supply circuit is used in this unit.
 If Main Fuse (F1001) is blown, check to see that all components in the power supply circuit are not defective before you connect the AC plug to the AC power supply.
 Otherwise it may cause some components in the power supply circuit to fail.

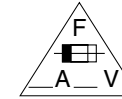

CAUTION !

For continued protection against fire hazard, replace only with the same type fuse.
 ATTENTION : Pour une protection continue les risques d'incendie n'utiliser que des fusibles de même type.

Risk of fire-replace fuse as marked.

"This symbol means fast operating fuse."
 "Ce symbole représente un fusible à fusion rapide."

NOTE:

The voltage for parts in hot circuit is measured using hot GND as a common terminal.

Because a hot chassis ground is present in the power supply circuit, an isolation transformer must be used. Also, in order to have the ability to increase the input slowly, when troubleshooting this type power supply circuit, a variable isolation transformer is required.

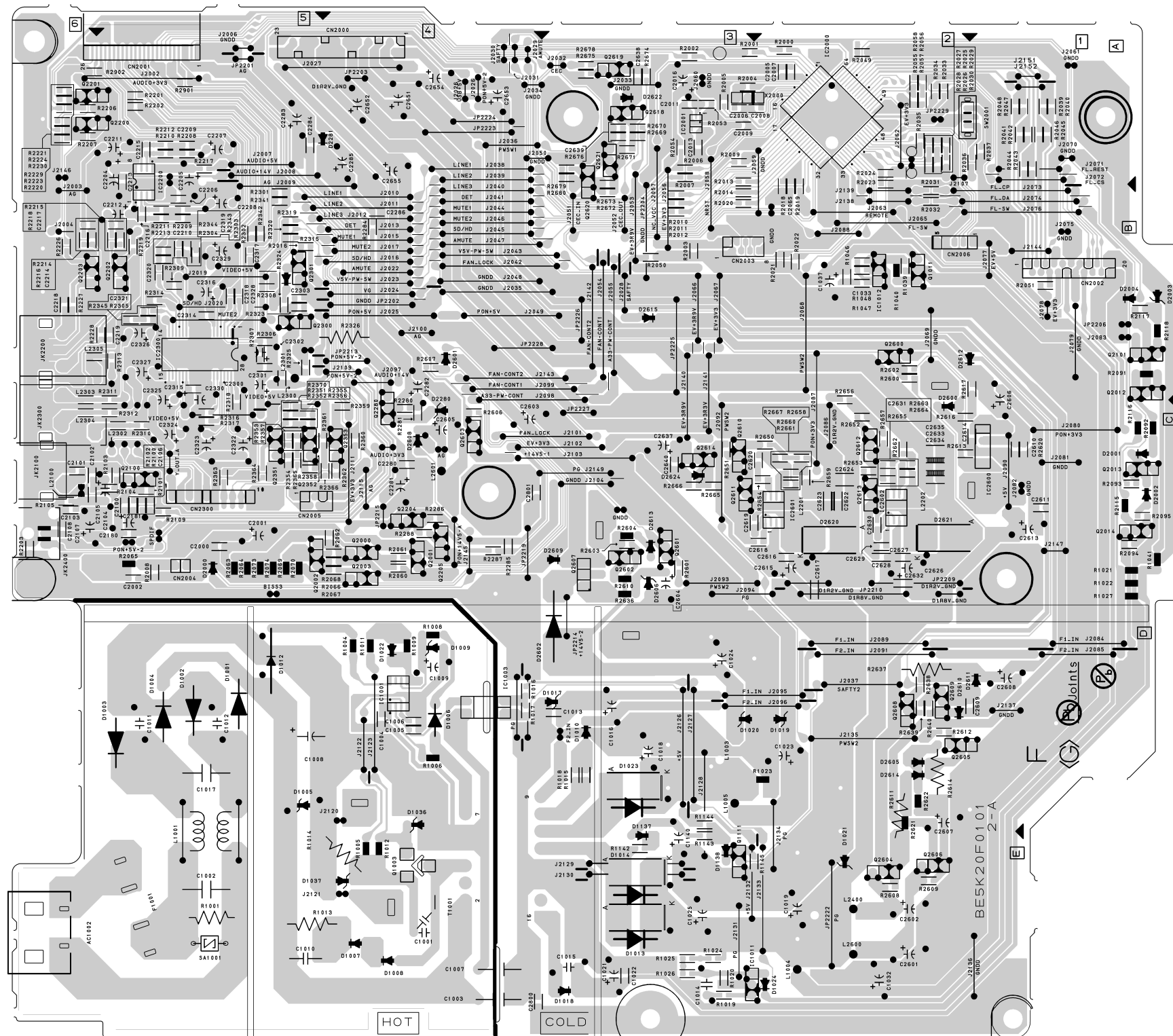

Front CBA Top View

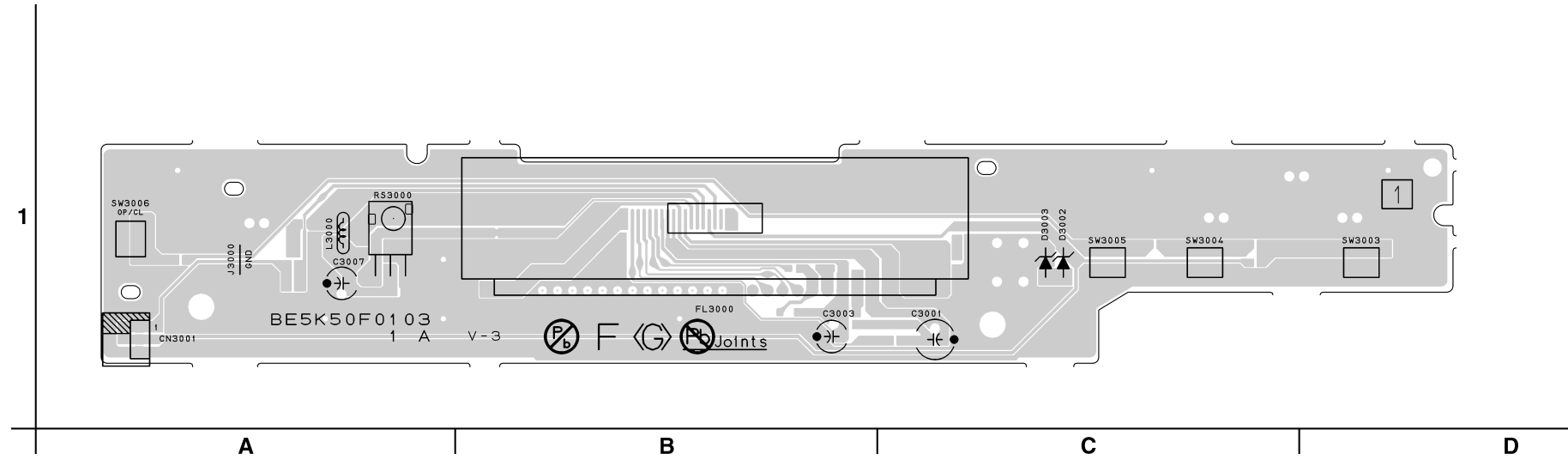

Power SW CBA Top View

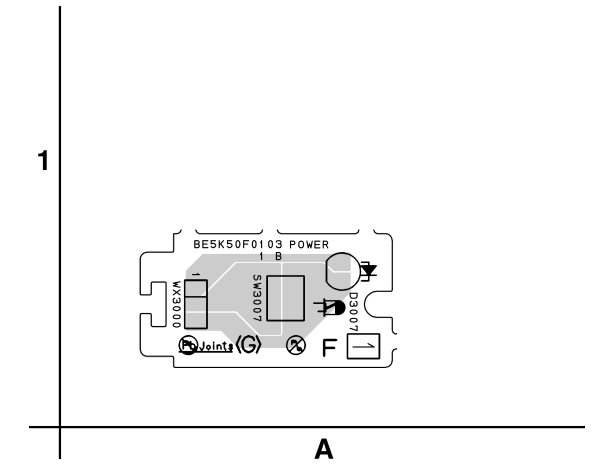

Front CBA Bottom View

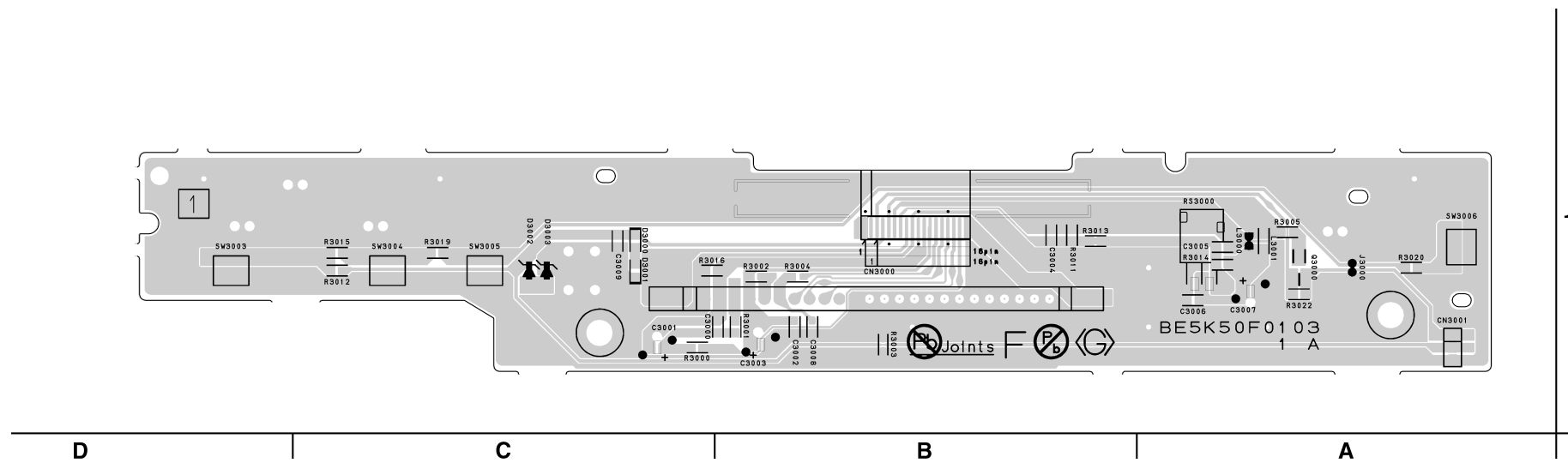

Power SW CBA Bottom View

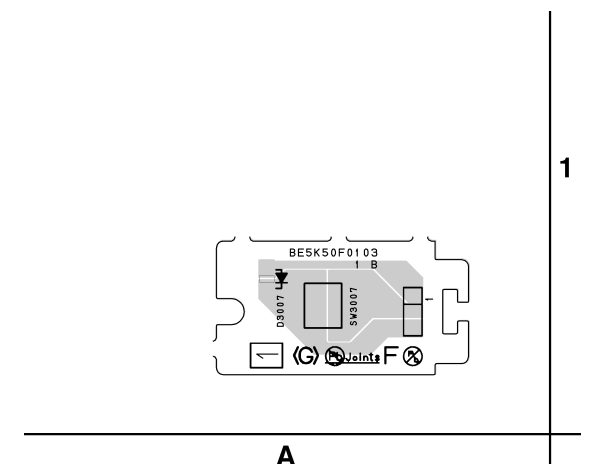

BE5K50F01031A

BE5K50F01031B

SD-A CBA Top View

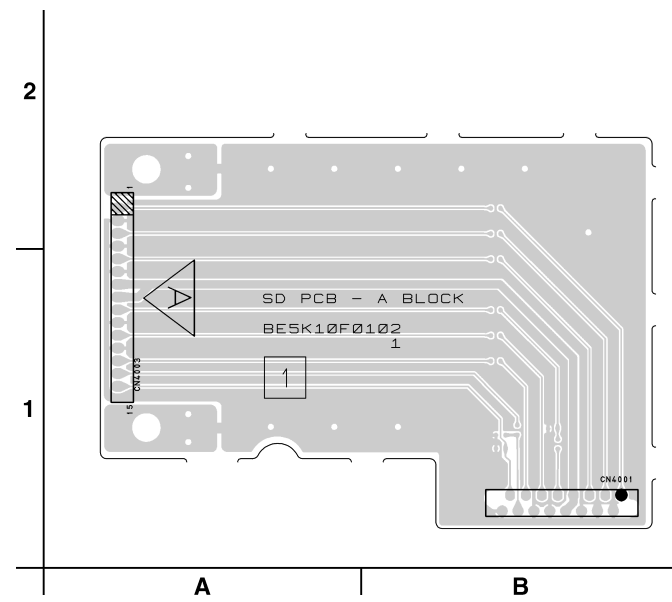

SD-B CBA Top View

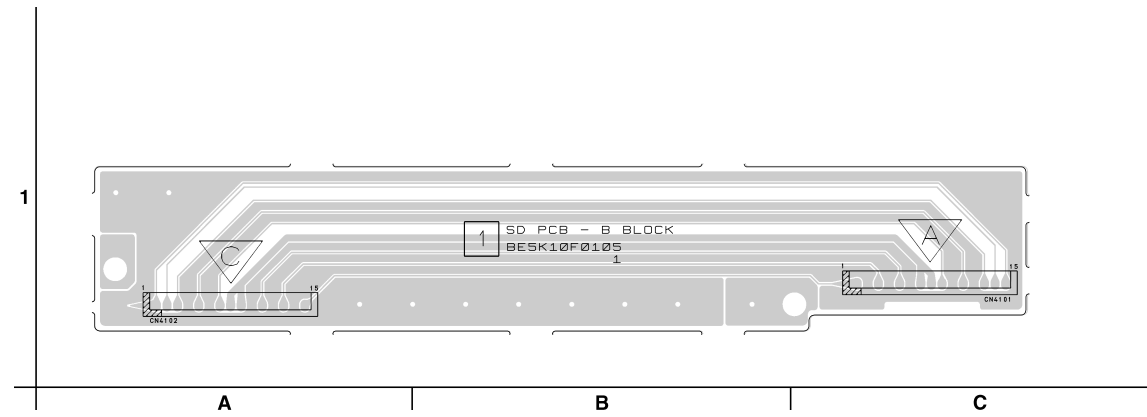

SD-C CBA Top View

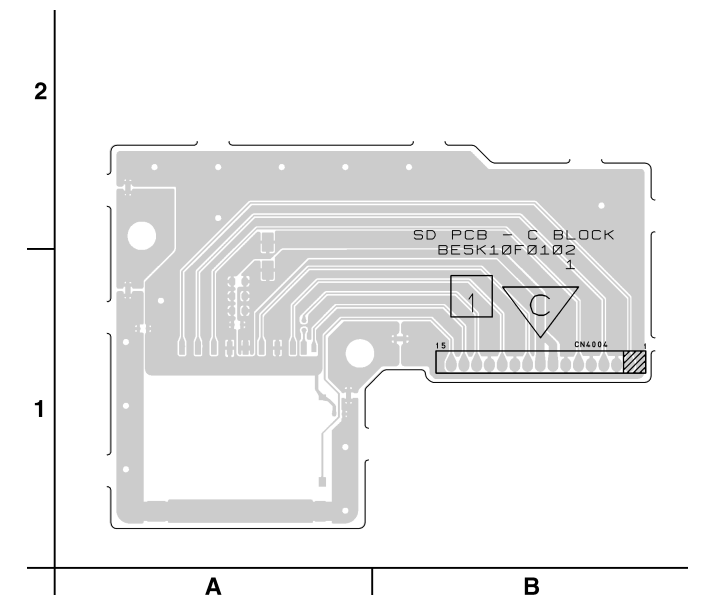

SD-A CBA Bottom View

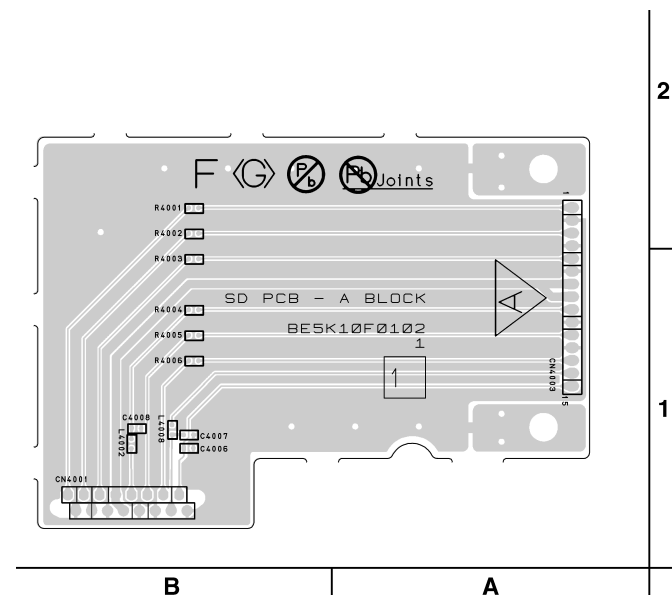

SD-B CBA Bottom View

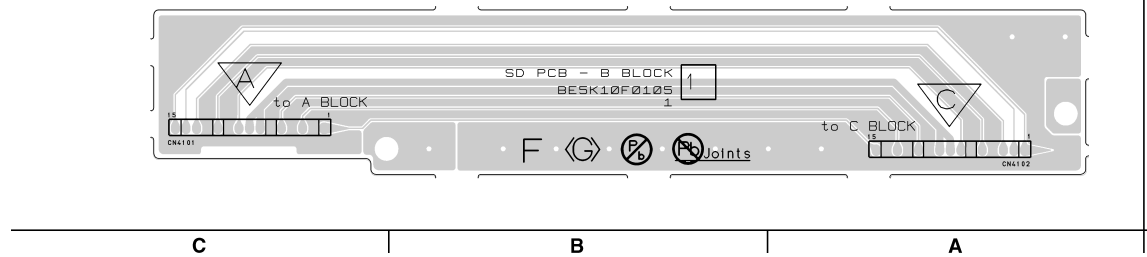

SD-C CBA Bottom View

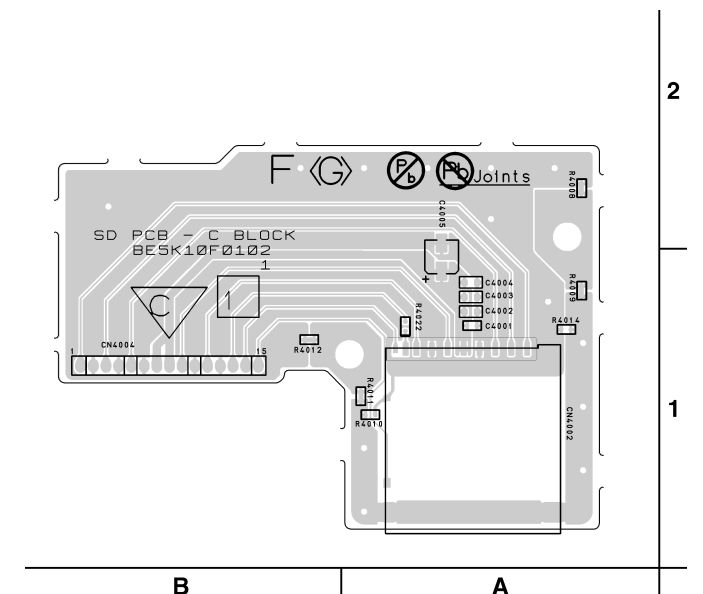

BE5K10F01021A

BE5K10F01051

BE5K10F01021C

Packing

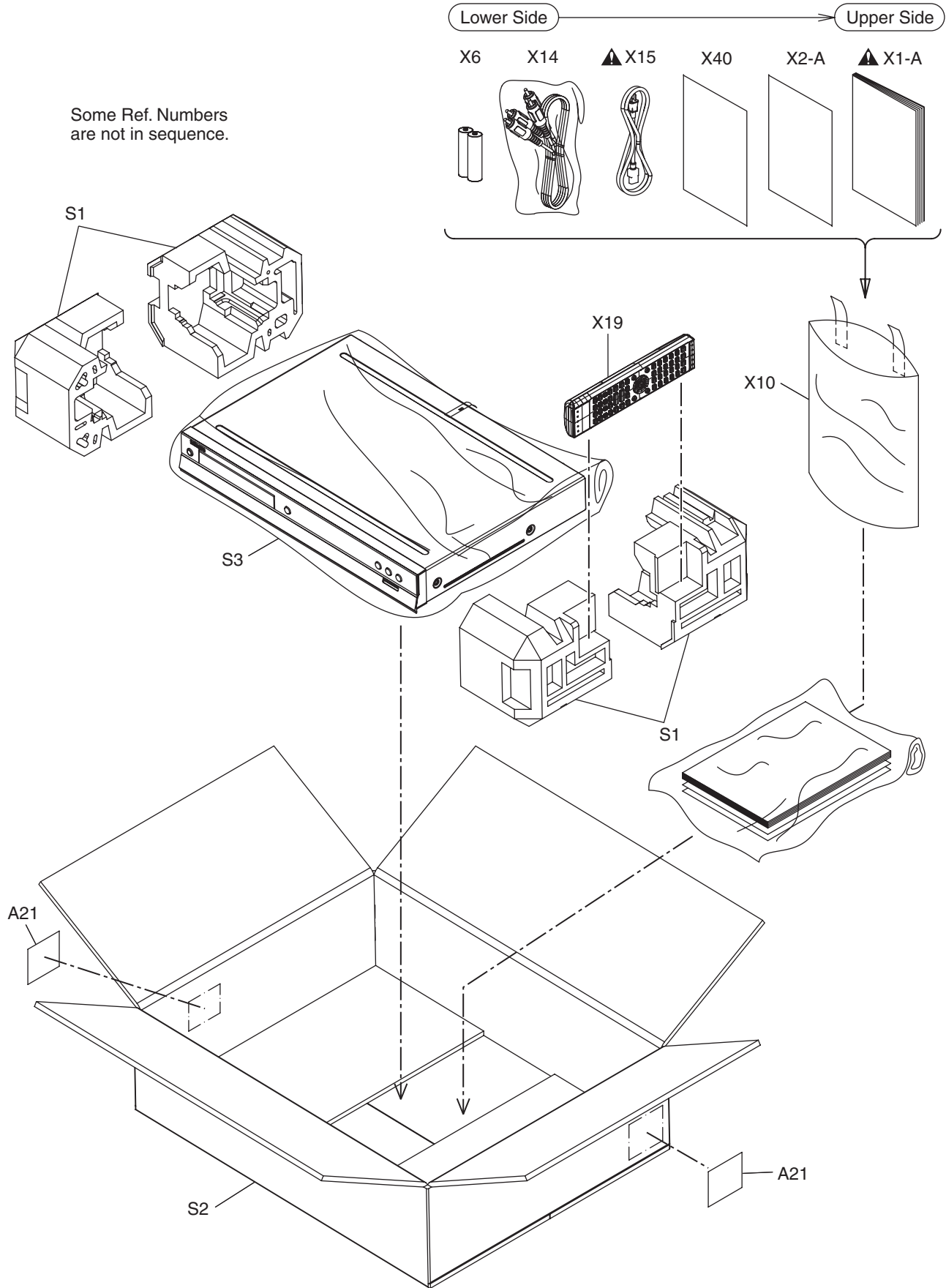

MECHANICAL PARTS LIST

PRODUCT SAFETY NOTE: Products marked with a  have special characteristics important to safety. Before replacing any of these components, read carefully the product safety notice in this service manual. Don't degrade the safety of the product through improper servicing.

NOTE: Parts that are not assigned part numbers (-----) are not available.

| Ref. No. | Description | Part No. |
|--|---|---------------|
| A1X | FRONT ASSEMBLY E5K55UD | 1VM123180 |
| A2 | CHASSIS E5K50UD | 1VM330278 |
| A3 | TOP COVER E5K20UD | 1VM122080 |
| A4 | REAR PANEL E5K55UD | 1VM227377 |
| A6 | FOOT ASSEMBLY E5H50UD | 1VM430199A |
| A21 | BAR CODE LABEL E5K55UD | ----- |
| A22 | LICENSE LABEL E5K12UD | ----- |
| 2L024 | SCREW P-TIGHT M3X8 BIND HEAD+ | GBJP3080 |
| 2L026 | SCREW C-TIGHT M3X6 E5610UD | 0VM412937A |
| 2L034 | SCREW C-TIGHT M3X6 E5610UD | 0VM412937A |
| 2L038 | SCREW C-TIGHT M3X6 E5610UD | 0VM412937A |
| 2L049 | SCREW C-TIGHT M3X6 E5610UD | 0VM412937A |
| 2L051 | SCREW C-TIGHT M3X6 E5610UD | 0VM412937A |
| 2L061 | HEXAGON SPACER E6AE0UD | 1VM424730 |
| 2L070 | B-TIGHT SCREW M3X8 E5E00UD | 1VM428563 |
| 2L071 | B-TIGHT SCREW M3X8 E5E00UD | 1VM428563 |
| 2L072 | SCREW TAP TIGHT M3X8 BIND PAN HEAD+BLK NI | GPHB3080 |
| 2L081 | S-TIGHT SCREW M3X6 E5E00UD | 1VM428564 |
| 2L082 | SCREW TAP TIGHT M3X5 BIND HEAD+BLK NI | GBHC3050 |
| 2L083 | S-TIGHT SCREW M3X6 E5E00UD | 1VM428564 |
| 2L084 | S-TIGHT SCREW M3X6 E5E00UD | 1VM428564 |
| 2L085 | SCREW S-TIGHT M3X10 E5610UD | 0VM412936A |
| 2L086 | SCREW S-TIGHT M3X5 E5K10UD | 1VM431079 |
| B4 | POWER HOLDER E5K20UD | 1VM225697 |
| B5 | FAN HOLDER E6700UD | 1VM320504L |
| B13 | SD PCB BRACKET E5K10UD | 1VM329203 |
| B15 | SHIELD BRACKET E5K10UD | 1VM226756 |
| B32 | MAIN PCB EARTH PLATE E5K20UD | 1VM430800 |
| B68 | FRONT SHIELD E5K20UD | 1VM328838 |
| B69 | PORON SPONGE E5K20UD | 1VM431100 |
| B70 | TAPE HIMERON(60*6) HG470ED | 1VM421170 |
| FM1001 | MOTOR DC FAN 2D57NL100010 | MMEZR12XNR05 |
| WX5500 | WIRE ASSEMBLY AV-RS232C 5PIN WIRE WX1E5K55-001 | WX1E5K55-001 |
| PACKING | | |
| S1 | SIDE PAD E5K50UD | 1VM123159 |
| S2 | GIFT BOX CARTON E5K55UD | 1VM330521 |
| S3 | SET BAG E7708UA | ODM400731D |
| ACCESSORIES | | |
| X1-A  | OWNERS MANUAL E5K55UD | 1VMN27613 |
| X2-A | QUICK GUIDE E5K55UD | 1VMN27614 |
| X6 | MANGANESE DRY BATTERY R6UWC/2STA | XB0M311MS003 |
| X10 | ACCESSORY BAG E5795ED | 0VM416059 |
| X14 | AV CORD 1000/BLACK | WFPZ0102TM018 |
| X15  | AC CORD WITH A GND WIRE UL/CSA/ 162/ NO/BLACK | WAV0162LW001 |
| X19 | REMOTE CONTROL UNIT NB822UD | NB822UD |
| X40 | WARRANTY CARD E5H55UD | 1VMN26326 |

ELECTRICAL PARTS LIST

PRODUCT SAFETY NOTE: Products marked with a **▲** have special characteristics important to safety. Before replacing any of these components, read carefully the product safety notice in this service manual. Don't degrade the safety of the product through improper servicing.

NOTES:

- Parts that are not assigned part numbers (-----) are not available.
- Tolerance of Capacitors and Resistors are noted with the following symbols.

C.....±0.25% D.....±0.5% F.....±1%
 G.....±2% J.....±5% K.....±10%
 M.....±20% N.....±30% Z.....+80/-20%

BD MAIN CBA & BD MECHANISM ASSEMBLY

| Ref. No. | Description | Part No. |
|----------|-------------------------------------|----------|
| 1B1 | BD MAIN CBA & BD MECHANISM ASSEMBLY | N77R1BUN |

AV CBA

| Ref. No. | Description | Part No. |
|-------------------|---|--------------|
| | AV CBA Consists of the following: | 1VSA22029 |
| CAPACITORS | | |
| C1001 | CAP CERAMIC 470pF/2KV/K | CA3D471PAN17 |
| C1002▲ | LINE ACROSS CAP. 0.047µF/250V K | CT2E473DC016 |
| C1004 | CHIP CERAMIC CAP.(1608) CH J 22pF/50V | CHD1JJ3CH220 |
| C1005 | CHIP CERAMIC CAP.(1608) B K 1000pF/50V | CHD1JK30B102 |
| C1006 | CHIP CERAMIC CAP.(1608) B K 0.033µF/50V | CHD1JK30B333 |
| C1007▲ | SAFETY CAP. 3300pF/250V | CCD2EMA0E332 |
| C1008 | ELECTROLYTIC CAPACITOR ZR200TA221K18EB | CA2D221DYG04 |
| C1009 | ELECTROLYTIC CAP. 47µF/35V/M | CEE47RENW016 |
| C1010 | METALIZED FILM CAP. 0.0022µF/400V K | CT2H222DT034 |
| C1013 | CHIP CERAMIC CAP.(1608) B K 0.01µF/50V | CHD1JK30B103 |
| C1014 | POLYESTER FILM CAP. (PB FREE) 0.0068µF/ 100V J | CA2A682DT018 |
| C1015 | CERAMIC CAP. B K 470pF/500V | CCD2JKS0B471 |
| C1016 | ELECTROLYTIC CAP. 220µF/10V M | CEB221ENW016 |
| C1017▲ | LINE ACROSS CAP. 0.047µF/250V K | CT2E473DC016 |
| C1018 | ELECTROLYTIC CAP 2200µF/25V/M | CED222ENW009 |
| C1019 | ELECTROLYTIC CAP 4700µF/6.3V/M | CEA472ENW009 |
| C1021 | ELECTROLYTIC CAP. 22µF/50V/M | CEF22RENW016 |
| C1022 | CHIP CERAMIC CAP.(1608) F Z 0.1µF/50V | CHD1JZ30F104 |
| C1023 | ELECTROLYTIC CAP. 220µF/25V/M | CED221ENW016 |
| C1024 | ELECTROLYTIC CAP 2200µF/25V/M | CED222ENW009 |
| C1025 | ELECTROLYTIC CAP 4700µF/6.3V/M | CEA472ENW009 |
| C1032 | ELECTROLYTIC CAP. 100µF/6.3V/M | CEA101ENW016 |
| C1033 | CHIP CERAMIC CAP.(1608) B K 0.01µF/50V | CHD1JK30B103 |
| C1037 | ELECTROLYTIC CAP. 47µF/6.3V/M | CEA47RENW016 |
| C1140 | ELECTROLYTIC CAP. 22µF/50V/M | CEF22RENW016 |
| C2000 | CHIP CERAMIC CAP.(1608) B K 0.1µF/25V | CHD1EK30B104 |
| C2001 | ELECTROLYTIC CAP. 100µF/16V/M | CEC101ENW016 |
| C2002 | CHIP CERAMIC CAP.(1608) B K 0.1µF/25V | CHD1EK30B104 |
| C2005 | CHIP CERAMIC CAP.(1608) F Z 0.1µF/50V | CHD1JZ30F104 |

| Ref. No. | Description | Part No. |
|----------|---|--------------|
| C2007 | CHIP CERAMIC CAP.(1608) F Z 0.1µF/50V | CHD1JZ30F104 |
| C2009 | CHIP CERAMIC CAP.(1608) CH J 100pF/50V | CHD1JJ3CH101 |
| C2011 | CHIP CERAMIC CAP.(1608) F Z 0.1µF/50V | CHD1JZ30F104 |
| C2013 | CHIP CERAMIC CAP.(1608) B K 0.015µF/50V | CHD1JK30B153 |
| C2016 | ELECTROLYTIC CAP. 47µF/6.3V/M | CEA47RENW016 |
| C2065 | CHIP CERAMIC CAP.(1608) B K 1000pF/50V | CHD1JK30B102 |
| C2100 | CHIP CERAMIC CAP.(1608) B K 0.1µF/25V | CHD1EK30B104 |
| C2104 | ELECTROLYTIC CAP. 47µF/6.3V/M | CEA47RENW016 |
| C2106 | CHIP CERAMIC CAP. CH D 8pF/50V | CHD1JD3CH8R0 |
| C2108 | CHIP CERAMIC CAP.(1608) F Z 0.1µF/50V | CHD1JZ30F104 |
| C2180 | CHIP CERAMIC CAP.(1608) F Z 0.1µF/50V | CHD1JZ30F104 |
| C2181 | ELECTROLYTIC CAP. 220µF/6.3V/M | CEA221ENW016 |
| C2204 | ELECTROLYTIC CAP. 47µF/25V/M | CEA47RENW016 |
| C2205 | ELECTROLYTIC CAP. 470µF/6.3V/M | CEA471ENW016 |
| C2206 | CHIP CERAMIC CAP.(1608) F Z 0.1µF/50V | CHD1JZ30F104 |
| C2207 | ELECTROLYTIC CAP. 10µF/16V/M | CEC10RENW016 |
| C2208 | ELECTROLYTIC CAP. 10µF/16V/M | CEC10RENW016 |
| C2209 | CHIP CERAMIC CAP. CH J 220pF/50V | CHD1JJ3CH221 |
| C2210 | CHIP CERAMIC CAP. CH J 220pF/50V | CHD1JJ3CH221 |
| C2211 | ELECTROLYTIC CAP. 10µF/16V/M | CEC10RENW016 |
| C2212 | ELECTROLYTIC CAP. 10µF/16V/M | CEC10RENW016 |
| C2213 | CHIP CERAMIC CAP.(1608) F Z 0.1µF/50V | CHD1JZ30F104 |
| C2215 | CHIP CERAMIC CAP. CH J 39pF/50V | CHD1JJ3CH390 |
| C2216 | CHIP CERAMIC CAP. CH J 39pF/50V | CHD1JJ3CH390 |
| C2280 | CHIP CERAMIC CAP.(1608) F Z 0.1µF/50V | CHD1JZ30F104 |
| C2281 | ELECTROLYTIC CAP. 220µF/6.3V/M | CEA221ENW016 |
| C2283 | ELECTROLYTIC CAP. 1000µF/6.3V/M | CEA102ENW016 |
| C2284 | CHIP CERAMIC CAP.(1608) F Z 0.1µF/50V | CHD1JZ30F104 |
| C2286 | CHIP CERAMIC CAP.(1608) F Z 0.1µF/50V | CHD1JZ30F104 |
| C2300 | ELECTROLYTIC CAP. 100µF/6.3V/M | CEA101ENW016 |
| C2301 | CHIP CERAMIC CAP.(1608) F Z 0.1µF/50V | CHD1JZ30F104 |
| C2314 | CHIP CERAMIC CAP.(1608) F Z 0.1µF/50V | CHD1JZ30F104 |
| C2315 | CHIP CERAMIC CAP.(1608) F Z 0.1µF/50V | CHD1JZ30F104 |
| C2316 | ELECTROLYTIC CAP. 22µF/6.3V/M | CEA22RENW016 |
| C2319 | CHIP CERAMIC CAP.(1608) B K 0.1µF/50V | CHD1JK30B104 |
| C2320 | CHIP CERAMIC CAP.(1608) B K 1µF/10V | CHD1AK30B105 |
| C2321 | CHIP CERAMIC CAP.(1608) B K 1µF/10V | CHD1AK30B105 |
| C2322 | ELECTROLYTIC CAP. 33µF/10V/M | CEB33RENW016 |
| C2323 | ELECTROLYTIC CAP. 330µF/6.3V/M | CEA331ENW016 |
| C2324 | ELECTROLYTIC CAP. 330µF/6.3V/M | CEA331ENW016 |
| C2325 | ELECTROLYTIC CAP. 33µF/10V/M | CEB33RENW016 |
| C2326 | ELECTROLYTIC CAP. 330µF/6.3V/M | CEA331ENW016 |
| C2327 | ELECTROLYTIC CAP. 330µF/6.3V/M | CEA331ENW016 |
| C2328 | CHIP CERAMIC CAP.(1608) B K 0.1µF/50V | CHD1JK30B104 |
| C2329 | ELECTROLYTIC CAP. 100µF/6.3V/M | CEA101ENW016 |
| C2330 | ELECTROLYTIC CAP. 100µF/6.3V/M | CEA101ENW016 |
| C2601 | ELECTROLYTIC CAP. 1000µF/6.3V/M | CEA102ENW016 |
| C2602 | ELECTROLYTIC CAP. 1000µF/6.3V/M | CEA102ENW016 |
| C2604 | ELECTROLYTIC CAP. 10µF/16V/M | CEC10RENW016 |
| C2605 | ELECTROLYTIC CAP. 47µF/25V/M | CED47RENW016 |
| C2606 | ELECTROLYTIC CAP. 100µF/6.3V/M | CEA101ENW016 |
| C2607 | ELECTROLYTIC CAP. 1000µF/6.3V/M | CEA102ENW016 |
| C2609 | CHIP CERAMIC CAP.(1608) B K 1µF/10V | CHD1AK30B105 |
| C2610 | CHIP CERAMIC CAP.(1608) B K 0.1µF/25V | CHD1EK30B104 |
| C2613 | ELECTROLYTIC CAP. 220µF/6.3V/M | CEA221ENW016 |
| C2614 | CHIP CERAMIC CAP.(1608) B K 0.33µF/10V | CHD1AK30B334 |
| C2616 | CHIP CERAMIC CAP.(1608) B K 1µF/10V | CHD1AK30B105 |
| C2618 | CHIP CERAMIC CAP.(1608) F Z 0.1µF/50V | CHD1JZ30F104 |
| C2619 | CHIP CERAMIC CAP.(1608) F Z 0.1µF/50V | CHD1JZ30F104 |
| C2620 | CHIP CERAMIC CAP. B K 8200pF/50V | CHD1JK30B822 |

| Ref. No. | Description | Part No. |
|------------|--|--------------|
| C2622 | CHIP CERAMIC CAP(2125) B K 10 μ F/6.3V | CHE0KK30B106 |
| C2623 | CHIP CERAMIC CAP(2125) B K 10 μ F/6.3V | CHE0KK30B106 |
| C2627 | CHIP CERAMIC CAP(1608) B K 1 μ F/10V | CHD1AK30B105 |
| C2629 | CHIP CERAMIC CAP(1608) F Z 0.1 μ F/50V | CHD1JZ30F104 |
| C2630 | CHIP CERAMIC CAP(1608) F Z 0.1 μ F/50V | CHD1JZ30F104 |
| C2631 | CHIP CERAMIC CAP(1608) B K 5600pF/50V | CHD1JK30B562 |
| C2632 | CHIP CERAMIC CAP(2125) B K 10 μ F/6.3V | CHE0KK30B106 |
| C2633 | CHIP CERAMIC CAP(2125) B K 10 μ F/6.3V | CHE0KK30B106 |
| C2634 | CHIP CERAMIC CAP(2125) B K 10 μ F/6.3V | CHE0KK30B106 |
| C2638 | CHIP CERAMIC CAP. CH J 330pF/50V | CHD1JJ3CH331 |
| C2639 | CHIP CERAMIC CAP. CH J 220pF/50V | CHD1JJ3CH221 |
| C2640 | CHIP CERAMIC CAP(1608) B K 0.01 μ F/6.3V | CHD1JK30B103 |
| C2652 | ELECTROLYTIC CAP. 330 μ F/6.3V/M | CEA331ENW016 |
| C2653 | ELECTROLYTIC CAP. 330 μ F/6.3V/M | CEA331ENW016 |
| C2655 | ELECTROLYTIC CAP. 470 μ F/16V/M | CEC471ENW016 |
| C2800 | CHIP CERAMIC CAP(1608) B K 0.01 μ F/50V | CHD1JK30B103 |
| C2801 | CHIP RES.(1608) 1/10W 0 Ω | RRXAZR5Z0000 |
| CONNECTORS | | |
| CN2000 | TWG CONNECTOR 23P TWG-P23P-A1 | J3TWA23TG001 |
| CN2001 | WIRE ASSEMBLY AV-MAIN 26P WX1E5K20-001 | WX1E5K20-001 |
| CN2002 | FFC CONNECTOR IMSA-9615S-16A-PP-A | JC96J16ER007 |
| CN2004 | PH CONNECTOR TOP 2P B2B-PH-K-S (LF)(SN) | J3PHC02JG029 |
| CN2006 | CONNECTOR PRINT OSU B5B-PH-K-S (LF)(SN) | J3PHC05JG029 |
| DIODES | | |
| D1001 | DIODE 1N5397-B | NDLZ001N5397 |
| D1002 | DIODE 1N5397-B | NDLZ001N5397 |
| D1003 | DIODE 1N5397-B | NDLZ001N5397 |
| D1004 | DIODE 1N5397-B | NDLZ001N5397 |
| D1006 | DIODE FR154 | NDLZ000FR154 |
| D1007 | RECTIFIER DIODE BA157 | NDQZ000BA157 |
| D1008 | RECTIFIER DIODE BA157 | NDQZ000BA157 |
| D1010 | RECTIFIER DIODE BA157 | NDQZ000BA157 |
| D1012 | PCB JUMPER D0.6-P15.0 | JW15.0T |
| D1013 | SCHOTTKY BARRIER DIODE SMD SK54 | ND1Z0000SK54 |
| D1014 | SCHOTTKY BARRIER DIODE SMD SK54 | ND1Z0000SK54 |
| D1017 | DIODE ZENER 5V1BSB-T26 | NDTB5R1BST26 |
| D1018 | RECTIFIER DIODE BA157 | NDQZ000BA157 |
| D1019 | DIODE ZENER 18BSB-T26 | NDTB018BST26 |
| D1020 | DIODE ZENER 18BSB-T26 | NDTB018BST26 |
| D1021 | DIODE ZENER 6V8BSB-T26 | NDTB6R8BST26 |
| D1022 | SCHOTTKY BARRIER DIODE SB140 | NDQZ000SB140 |
| D1023 | SCHOTTKY BARRIER DIODE SMD SK39 | ND1Z0000SK39 |
| D1024 | DIODE SWITCHING 1N4148-F0021 | NDT01N4148F |
| D1036 | DIODE ZENER 27BSB-T26 | NDTB027BST26 |
| D1037 | DIODE ZENER 27BSB-T26 | NDTB027BST26 |
| D1137 | RECTIFIER DIODE BA157 | NDQZ000BA157 |
| D1138 | DIODE SWITCHING 1N4148-F0021 | NDT01N4148F |
| D2001 | DIODE SWITCHING 1N4148-F0021 | NDT01N4148F |
| D2002 | DIODE SWITCHING 1N4148-F0021 | NDT01N4148F |
| D2003 | DIODE ZENER 36BSA-T26 | NDTA036BST26 |
| D2004 | DIODE SWITCHING 1N4148-F0021 | NDT01N4148F |
| D2600 | DIODE SWITCHING 1N4148-F0021 | NDT01N4148F |
| D2601 | DIODE SWITCHING 1N4148-F0021 | NDT01N4148F |
| D2602 | DIODE 1N5406 | NDLZ001N5406 |
| D2605 | DIODE SWITCHING 1N4148-F0021 | NDT01N4148F |
| D2606 | DIODE ZENER 11BSC-T26 | NDTC011BST26 |
| D2608 | DIODE SWITCHING 1N4148-F0021 | NDT01N4148F |
| D2609 | DIODE SWITCHING 1N4148-F0021 | NDT01N4148F |
| D2610 | DIODE SWITCHING 1N4148-F0021 | NDT01N4148F |
| D2612 | DIODE SWITCHING 1N4148-F0021 | NDT01N4148F |

| Ref. No. | Description | Part No. |
|-------------|---|--------------|
| D2613 | DIODE SWITCHING 1N4148-F0021 | NDT01N4148F |
| D2614 | DIODE SWITCHING 1N4148-F0021 | NDT01N4148F |
| D2615 | DIODE SWITCHING 1N4148-F0021 | NDT01N4148F |
| D2620 | SCHOTTKY BARRIER DIODE SMD SK34 | ND1Z0000SK34 |
| D2621 | SCHOTTKY BARRIER DIODE SMD SK34 | ND1Z0000SK34 |
| D2624 | DIODE ZENER 4V7BSB-T26 | NDTB4R7BST26 |
| ICS | | |
| IC1001 | IC SWITCHING FA5542N-A2-TE1 SOP8 | QSZA0TFD005 |
| IC1003▲ | PHOTOCOUPLER PS2561A-1(W) | QPEWPS2561A1 |
| IC1011 | IC SHUNT REGULATOR SL431A-AT | NSZBA0TAUK01 |
| IC1012 | IC SHUNT REGULATOR SL431A-AT | NSZBA0TAUK01 |
| IC2000 | IC SUB MICON MN101C77A GC | QSAAR0M0S010 |
| IC2001 | RESET IC S-80930CNMC-G80T2G | QSCA0T0SK018 |
| IC2200 | IC OP AMP UTC4580TE | NSCA0T02H001 |
| IC2300 | IC VIDEO DRIVER MM1757EHBE | QSCA0T0MM001 |
| IC2600 | IC VOLTAGE REGULATOR PQ070XFC1SZF / 4PIN | QSZBAORSH083 |
| IC2601 | IC DC-DC CONVERTER BD9323EFJ-E2 | QSCA0T0RM002 |
| IC2602 | IC DC-DC CONVERTER BD9323EFJ-E2 | QSCA0T0RM002 |
| COILS | | |
| L1001▲ | LINE FILTER 27MH 5703 | LLBG002KT009 |
| L1003 | POWER INDUCTORS CWKBNP-220K | LLF2200KV002 |
| L1004 | RADIAL TYPE CHOKE COIL CW68-470K-841040NP | LLBD00PKV023 |
| L1005 | CHOKE COIL 22 μ H-K | LLBD00PKV021 |
| L2100 | INDUCTOR(0.47 μ H K) LAP02TAR47K | LLAXKATTUR47 |
| L2201 | POWER INDUCTORS CWKBNP-100K | LLF1000KV002 |
| L2202 | POWER INDUCTORS CWKBNP-100K | LLF1000KV002 |
| L2300 | RADIAL TYPE CHOKE COIL CW68-470K-841040NP | LLBD00PKV023 |
| L2301 | CHIP RES.(1608) 1/10W 0 Ω | RRXAZR5Z0000 |
| L2306 | PCB JUMPER D0.6-P5.0 | JW5.0T |
| L2400 | CHOKE COIL 22 μ H-K | LLBD00PKV021 |
| L2600 | CHOKE COIL 22 μ H-K | LLBD00PKV021 |
| L2601 | CHOKE COIL 22 μ H-K | LLBD00PKV021 |
| TRANSISTORS | | |
| Q1003▲ | FET MOS 2SK3563(Q M) | QFQZSK3563QM |
| Q1011 | NPN TRANSISTOR 2SC5344 Y | NQSY02SC5344 |
| Q1111 | NPN TRANSISTOR 2SC5343MG-AT | NQSG2SC5343M |
| Q2000 | PNP TRANSISTOR 2SA1980M Y | NQSY2SA1980M |
| Q2001 | NPN TRANSISTOR RES-IN SRC1203MAT | NQSZSRC1203M |
| Q2002 | PNP TRANSISTOR 2SA1980M Y | NQSY2SA1980M |
| Q2003 | NPN TRANSISTOR RES-IN SRC1203MAT | NQSZSRC1203M |
| Q2012 | PNP TRANSISTOR 2SA1980M Y | NQSY2SA1980M |
| Q2013 | NPN TRANSISTOR 2SC5343MG-AT | NQSG2SC5343M |
| Q2014 | PNP TRANSISTOR 2SA1981Y-AT | NQSY02SA1981 |
| Q2100 | NPN TRANSISTOR 2SC5343MG-AT | NQSG2SC5343M |
| Q2101 | NPN TRANSISTOR 2SC5343MG-AT | NQSG2SC5343M |
| Q2200 | PNP TRANSISTOR RES-IN SRA2205M | NQSZSRA2205M |
| Q2201 | PNP TRANSISTOR RES-IN SRA2205M | NQSZSRA2205M |
| Q2202 | NPN TRANSISTOR 2SC5343MG-AT | NQSG2SC5343M |
| Q2203 | NPN TRANSISTOR 2SC5343MG-AT | NQSG2SC5343M |
| Q2204 | PNP TRANSISTOR 2SA1980M Y | NQSY2SA1980M |
| Q2205 | NPN TRANSISTOR 2SC5343MG-AT | NQSG2SC5343M |
| Q2600 | NPN TRANSISTOR RES-IN SRC1203MAT | NQSZSRC1203M |
| Q2601 | NPN TRANSISTOR 2SC5343MG-AT | NQSG2SC5343M |
| Q2602 | PNP TRANSISTOR 2SA1980M Y | NQSY2SA1980M |
| Q2603 | PNP TRANSISTOR 2SA1981Y-AT | NQSY02SA1981 |
| Q2604 | PNP TRANSISTOR STB1277LY-AT | NQSYSTB1277L |
| Q2605 | NPN TRANSISTOR 2SC5344 Y | NQSY02SC5344 |
| Q2606 | PNP TRANSISTOR STB1277LY-AT | NQSYSTB1277L |
| Q2607 | TRANSISTOR(PB FREE) KTC2026-Y/P | NQEYKTC2026P |
| Q2608 | PNP TRANSISTOR 2SA1980MG-AT | NQSG2SA1980M |

| Ref. No. | Description | Part No. |
|-----------|-----------------------------------|--------------|
| Q2609 | NPN TRANSISTOR 2SC5343MG-AT | NQSG2SC5343M |
| Q2610 | NPN TRANSISTOR 2SC5343MG-AT | NQSG2SC5343M |
| Q2611 | NPN TRANSISTOR 2SC5343MG-AT | NQSG2SC5343M |
| Q2612 | NPN TRANSISTOR 2SC5343MG-AT | NQSG2SC5343M |
| Q2613 | NPN TRANSISTOR 2SC5343MG-AT | NQSG2SC5343M |
| Q2614 | NPN TRANSISTOR 2SC5343MG-AT | NQSG2SC5343M |
| Q2618 | NPN TRANSISTOR 2SC5343MG-AT | NQSG2SC5343M |
| Q2619 | NPN TRANSISTOR 2SC5343MG-AT | NQSG2SC5343M |
| Q2620 | NPN TRANSISTOR 2SC5343MG-AT | NQSG2SC5343M |
| Q2621 | NPN TRANSISTOR 2SC5343MG-AT | NQSG2SC5343M |
| RESISTORS | | |
| R1004 | CARBON RES. 1/4W J 75k Ω | RCX4JATZ0753 |
| R1005 | CARBON RES. 1/4W J 33 Ω | RCX4JATZ0330 |
| R1006 | CARBON RES. 1/4W J 100k Ω | RCX4JATZ0104 |
| R1008 | CARBON RES. 1/4W J 56 Ω | RCX4JATZ0560 |
| R1009 | CARBON RES. 1/4W J 100 Ω | RCX4JATZ0101 |
| R1011 | CARBON RES. 1/4W J 10 Ω | RCX4JATZ0100 |
| R1012 | CARBON RES. 1/4W J 4.7k Ω | RCX4JATZ0472 |
| R1013 | METAL OXIDE FILM RES. 2W J 47k Ω | RN02473ZU001 |
| R1014 | METAL OXIDE FILM RES. 2W J 0.68 Ω | RN02R68ZU001 |
| R1015 | CHIP RES. 1/10W J 1 Ω | RRXAJR5Z01R0 |
| R1016 | CHIP RES. 1/10W J 470 Ω | RRXAJR5Z0471 |
| R1017 | CHIP RES. 1/10W J 22k Ω | RRXAJR5Z0223 |
| R1018 | CHIP RES. 1/10W J 1 Ω | RRXAJR5Z01R0 |
| R1019 | CHIP RES. 1/10W J 680 Ω | RRXAJR5Z0681 |
| R1020 | CHIP RES. 1/10W F 2k Ω | RRXAFR5H2001 |
| R1021 | CARBON RES. 1/4W J 10k Ω | RCX4JATZ0103 |
| R1022 | CARBON RES. 1/4W J 10k Ω | RCX4JATZ0103 |
| R1023 | CARBON RES. 1/4W J 5.1k Ω | RCX4JATZ0512 |
| R1024 | CHIP RES. 1/10W F 270 Ω | RRXAFR5H2700 |
| R1025 | CHIP RES. 1/10W F 1.0k Ω | RRXAFR5H1001 |
| R1026 | CHIP RES. 1/10W F 1.0k Ω | RRXAFR5H1001 |
| R1027 | CARBON RES. 1/4W J 10k Ω | RCX4JATZ0103 |
| R1039 | CHIP RES. 1/10W J 1k Ω | RRXAJR5Z0102 |
| R1040 | CARBON RES. 1/4W J 100 Ω | RCX4JATZ0101 |
| R1041 | PCB JUMPER D0.6-P5.0 | JW5.0T |
| R1046 | CHIP RES. 1/10W F 1.5k Ω | RRXAFR5H1501 |
| R1047 | CHIP RES. 1/10W F 100 Ω | RRXAFR5H1000 |
| R1048 | CHIP RES. 1/10W F 4.7k Ω | RRXAFR5H4701 |
| R1142 | CHIP RES. 1/10W J 1 Ω | RRXAJR5Z01R0 |
| R1143 | CHIP RES. 1/10W F 18k Ω | RRXAFR5H1802 |
| R1144 | CHIP RES. 1/10W F 10k Ω | RRXAFR5H1002 |
| R1145 | CHIP RES. 1/10W J 330k Ω | RRXAJR5Z0334 |
| R2000 | CHIP RES. 1/10W J 1k Ω | RRXAJR5Z0102 |
| R2001 | CHIP RES. 1/10W J 100 Ω | RRXAJR5Z0101 |
| R2002 | CHIP RES. 1/10W J 100 Ω | RRXAJR5Z0101 |
| R2004 | CHIP RES. 1/10W J 470 Ω | RRXAJR5Z0471 |
| R2005 | CHIP RES.(1608) 1/10W 0 Ω | RRXAZR5Z0000 |
| R2006 | CHIP RES. 1/10W J 100 Ω | RRXAJR5Z0101 |
| R2007 | CHIP RES. 1/10W J 100 Ω | RRXAJR5Z0101 |
| R2008 | CHIP RES. 1/10W J 47k Ω | RRXAJR5Z0473 |
| R2018 | CHIP RES. 1/10W J 39k Ω | RRXAJR5Z0393 |
| R2019 | CHIP RES. 1/10W J 22k Ω | RRXAJR5Z0223 |
| R2020 | CHIP RES. 1/10W J 100 Ω | RRXAJR5Z0101 |
| R2024 | CHIP RES. 1/10W J 10k Ω | RRXAJR5Z0103 |
| R2025 | CHIP RES. 1/10W J 10k Ω | RRXAJR5Z0103 |
| R2028 | CHIP RES. 1/10W J 10k Ω | RRXAJR5Z0103 |
| R2029 | CHIP RES. 1/10W J 10k Ω | RRXAJR5Z0103 |
| R2031 | CHIP RES. 1/10W J 100 Ω | RRXAJR5Z0101 |
| R2032 | CHIP RES. 1/10W J 100 Ω | RRXAJR5Z0101 |
| R2033 | CHIP RES. 1/10W J 100 Ω | RRXAJR5Z0101 |
| R2034 | CHIP RES.(1608) 1/10W 0 Ω | RRXAZR5Z0000 |

| Ref. No. | Description | Part No. |
|----------|--------------------------------|--------------|
| R2035 | CHIP RES. 1/10W J 10k Ω | RRXAJR5Z0103 |
| R2039 | CHIP RES. 1/10W J 680 Ω | RRXAJR5Z0681 |
| R2050 | CHIP RES. 1/10W J 10k Ω | RRXAJR5Z0103 |
| R2051 | CHIP RES. 1/10W J 1k Ω | RRXAJR5Z0102 |
| R2053 | CHIP RES. 1/10W J 47k Ω | RRXAJR5Z0473 |
| R2056 | CHIP RES. 1/10W J 10k Ω | RRXAJR5Z0103 |
| R2058 | CHIP RES. 1/10W J 10k Ω | RRXAJR5Z0103 |
| R2060 | CHIP RES. 1/10W J 47k Ω | RRXAJR5Z0473 |
| R2061 | CHIP RES. 1/10W J 5.6k Ω | RRXAJR5Z0562 |
| R2063 | CARBON RES. 1/4W J 620 Ω | RCX4JATZ0621 |
| R2064 | CARBON RES. 1/4W J 620 Ω | RCX4JATZ0621 |
| R2065 | CARBON RES. 1/4W J 10 Ω | RCX4JATZ0100 |
| R2066 | CHIP RES. 1/10W J 47k Ω | RRXAJR5Z0473 |
| R2067 | CHIP RES. 1/10W J 5.6k Ω | RRXAJR5Z0562 |
| R2069 | CARBON RES. 1/4W J 120 Ω | RCX4JATZ0121 |
| R2070 | CARBON RES. 1/4W J 120 Ω | RCX4JATZ0121 |
| R2073 | CARBON RES. 1/4W J 620 Ω | RCX4JATZ0621 |
| R2074 | CARBON RES. 1/4W J 620 Ω | RCX4JATZ0621 |
| R2091 | CARBON RES. 1/4W J 47k Ω | RCX4JATZ0473 |
| R2092 | CARBON RES. 1/4W J 47k Ω | RCX4JATZ0473 |
| R2093 | CHIP RES. 1/10W J 10k Ω | RRXAJR5Z0103 |
| R2094 | CHIP RES. 1/10W J 47k Ω | RRXAJR5Z0473 |
| R2095 | CHIP RES. 1/10W J 3.9k Ω | RRXAJR5Z0392 |
| R2100 | CHIP RES. 1/10W J 2k Ω | RRXAJR5Z0202 |
| R2101 | CHIP RES. 1/10W J 2.2k Ω | RRXAJR5Z0222 |
| R2102 | CHIP RES. 1/10W J 2.2k Ω | RRXAJR5Z0222 |
| R2103 | CHIP RES. 1/10W J 220 Ω | RRXAJR5Z0221 |
| R2104 | CHIP RES. 1/10W J 75 Ω | RRXAJR5Z0750 |
| R2105 | CHIP RES. 1/10W J 100k Ω | RRXAJR5Z0104 |
| R2109 | CHIP RES.(1608) 1/10W 0 Ω | RRXAZR5Z0000 |
| R2115 | CARBON RES. 1/4W J 5.6 Ω | RCX4JATZ05R6 |
| R2116 | CARBON RES. 1/4W J 5.6 Ω | RCX4JATZ05R6 |
| R2117 | CHIP RES. 1/10W J 1k Ω | RRXAJR5Z0102 |
| R2118 | CARBON RES. 1/4W J 10 Ω | RCX4JATZ0100 |
| R2208 | CHIP RES. 1/10W F 24k Ω | RRXAFR5H2402 |
| R2209 | CHIP RES. 1/10W F 24k Ω | RRXAFR5H2402 |
| R2210 | CHIP RES. 1/10W J 8.2k Ω | RRXAJR5Z0822 |
| R2211 | CHIP RES. 1/10W J 8.2k Ω | RRXAJR5Z0822 |
| R2212 | CHIP RES. 1/10W F 33.0k Ω | RRXAFR5H3302 |
| R2213 | CHIP RES. 1/10W F 33.0k Ω | RRXAFR5H3302 |
| R2214 | CHIP RES. 1/10W J 100k Ω | RRXAJR5Z0104 |
| R2215 | CHIP RES. 1/10W J 100k Ω | RRXAJR5Z0104 |
| R2216 | CHIP RES. 1/10W J 820 Ω | RRXAJR5Z0821 |
| R2217 | CHIP RES. 1/10W J 1k Ω | RRXAJR5Z0102 |
| R2218 | CHIP RES. 1/10W J 820 Ω | RRXAJR5Z0821 |
| R2219 | CHIP RES. 1/10W J 1k Ω | RRXAJR5Z0102 |
| R2220 | CHIP RES. 1/10W J 100k Ω | RRXAJR5Z0104 |
| R2221 | CHIP RES. 1/10W J 100k Ω | RRXAJR5Z0104 |
| R2223 | CHIP RES. 1/10W J 4.7k Ω | RRXAJR5Z0472 |
| R2224 | CHIP RES. 1/10W J 2.2k Ω | RRXAJR5Z0222 |
| R2226 | CHIP RES. 1/10W J 1k Ω | RRXAJR5Z0102 |
| R2227 | CHIP RES. 1/10W J 220 Ω | RRXAJR5Z0221 |
| R2228 | CHIP RES. 1/10W J 220 Ω | RRXAJR5Z0221 |
| R2229 | CHIP RES. 1/10W J 2.2k Ω | RRXAJR5Z0222 |
| R2230 | CHIP RES. 1/10W J 4.7k Ω | RRXAJR5Z0472 |
| R2284 | CHIP RES. 1/10W J 10 Ω | RRXAJR5Z0100 |
| R2285 | CHIP RES. 1/10W J 10k Ω | RRXAJR5Z0103 |
| R2286 | CHIP RES. 1/10W J 10k Ω | RRXAJR5Z0103 |
| R2287 | CHIP RES. 1/10W J 10k Ω | RRXAJR5Z0103 |
| R2288 | CHIP RES. 1/10W J 1.8k Ω | RRXAJR5Z0182 |
| R2301 | CHIP RES.(1608) 1/10W F 82.0 Ω | RRXAFR5H82R0 |
| R2302 | CHIP RES.(1608) 1/10W F 82.0 Ω | RRXAFR5H82R0 |
| R2303 | CHIP RES.(1608) 1/10W F 82.0 Ω | RRXAFR5H82R0 |

| Ref. No. | Description | Part No. |
|----------|----------------------------------|--------------|
| R2304 | CHIP RES.(1608) 1/10W F 82.0 Ω | RRXAFR5H82R0 |
| R2305 | CHIP RES.(1608) 1/10W F 82.0 Ω | RRXAFR5H82R0 |
| R2307 | CHIP RES.(1608) 1/10W 0 Ω | RRXAZR5Z0000 |
| R2309 | CHIP RES. 1/10W J 10k Ω | RRXAJR5Z0103 |
| R2310 | CHIP RES. 1/10W J 75 Ω | RRXAJR5Z0750 |
| R2311 | CHIP RES. 1/10W J 75 Ω | RRXAJR5Z0750 |
| R2312 | CHIP RES. 1/10W J 75 Ω | RRXAJR5Z0750 |
| R2313 | CHIP RES. 1/10W J 75 Ω | RRXAJR5Z0750 |
| R2315 | CHIP RES. 1/10W J 27k Ω | RRXAJR5Z0273 |
| R2325 | CHIP RES.(1608) 1/10W 0 Ω | RRXAZR5Z0000 |
| R2341 | CHIP RES. 1/10W F 4.7k Ω | RRXAFR5H4701 |
| R2342 | CHIP RES. 1/10W F 2.7k Ω | RRXAFR5H2701 |
| R2343 | CHIP RES. 1/10W F 1.5k Ω | RRXAFR5H1501 |
| R2344 | CHIP RES. 1/10W F 1.2k Ω | RRXAFR5H1201 |
| R2345 | CHIP RES. 1/10W F 1.2k Ω | RRXAFR5H1201 |
| R2600 | CHIP RES. 1/10W J 4.7k Ω | RRXAJR5Z0472 |
| R2601 | CHIP RES. 1/10W J 4.7k Ω | RRXAJR5Z0472 |
| R2602 | CHIP RES. 1/10W J 2.2k Ω | RRXAJR5Z0222 |
| R2603 | CHIP RES. 1/10W J 4.7k Ω | RRXAJR5Z0472 |
| R2604 | CARBON RES. 1/4W J 4.7k Ω | RCX4JATZ0472 |
| R2606 | CHIP RES. 1/10W J 47k Ω | RRXAJR5Z0473 |
| R2607 | CHIP RES. 1/10W J 4.7k Ω | RRXAJR5Z0472 |
| R2608 | CHIP RES. 1/10W J 4.7k Ω | RRXAJR5Z0472 |
| R2609 | CHIP RES. 1/10W J 4.7k Ω | RRXAJR5Z0472 |
| R2610 | CARBON RES. 1/4W J 220 Ω | RCX4JATZ0221 |
| R2612 | CHIP RES. 1/10W J 10k Ω | RRXAJR5Z0103 |
| R2613 | CHIP RES. 1/10W F 10k Ω | RRXAFR5H1002 |
| R2616 | CHIP RES. 1/10W F 15k Ω | RRXAFR5H1502 |
| R2617 | CHIP RES. 1/10W F 2k Ω | RRXAFR5H2001 |
| R2620 | CHIP RES. 1/10W J 4.7k Ω | RRXAJR5Z0472 |
| R2621 | CARBON RES. 1/4W J 82 Ω | RCX4JATZ0820 |
| R2622 | CARBON RES. 1/4W J 82 Ω | RCX4JATZ0820 |
| R2636 | CARBON RES. 1/4W J 33 Ω | RCX4JATZ0330 |
| R2637 | METAL OXIDE FILM RES. 1W J 1.2 Ω | RN011R2ZU001 |
| R2638 | CHIP RES. 1/10W J 10k Ω | RRXAJR5Z0103 |
| R2639 | CHIP RES. 1/10W J 10k Ω | RRXAJR5Z0103 |
| R2650 | CHIP RES. 1/10W J 1k Ω | RRXAJR5Z0102 |
| R2651 | CHIP RES. 1/10W J 10k Ω | RRXAJR5Z0103 |
| R2652 | CHIP RES. 1/10W J 1k Ω | RRXAJR5Z0102 |
| R2653 | CHIP RES. 1/10W J 10k Ω | RRXAJR5Z0103 |
| R2654 | CHIP RES. 1/10W J 5.1k Ω | RRXAJR5Z0512 |
| R2655 | CHIP RES. 1/10W J 8.2k Ω | RRXAJR5Z0822 |
| R2656 | CHIP RES. 1/10W J 1k Ω | RRXAJR5Z0102 |
| R2657 | CHIP RES. 1/10W J 2.7k Ω | RRXAJR5Z0272 |
| R2658 | CHIP RES. 1/10W J 1k Ω | RRXAJR5Z0102 |
| R2659 | CHIP RES.(1608) 1/10W 0 Ω | RRXAZR5Z0000 |
| R2660 | CHIP RES. 1/10W F 1.5k Ω | RRXAFR5H1501 |
| R2661 | CHIP RES. 1/10W F 3.3k Ω | RRXAFR5H3301 |
| R2662 | CHIP RES. 1/10W F 1.5k Ω | RRXAFR5H1501 |
| R2663 | CHIP RES. 1/10W F 2.2k Ω | RRXAFR5H2201 |
| R2664 | CHIP RES. 1/10W F 3.3k Ω | RRXAFR5H3301 |
| R2665 | CHIP RES. 1/10W J 100 Ω | RRXAJR5Z0101 |
| R2667 | CHIP RES. 1/10W J 330 Ω | RRXAJR5Z0331 |
| R2669 | CHIP RES. 1/10W J 27k Ω | RRXAJR5Z0273 |
| R2671 | CHIP RES. 1/10W J 220k Ω | RRXAJR5Z0224 |
| R2673 | CHIP RES. 1/10W J 2.2M Ω | RRXAJR5Z0225 |
| R2674 | CHIP RES. 1/10W J 100k Ω | RRXAJR5Z0104 |
| R2675 | CHIP RES. 1/10W J 220 Ω | RRXAJR5Z0221 |
| R2676 | CHIP RES. 1/10W J 100k Ω | RRXAJR5Z0104 |
| R2678 | CHIP RES.(1608) 1/10W 0 Ω | RRXAZR5Z0000 |
| R2679 | CHIP RES. 1/10W J 47k Ω | RRXAJR5Z0473 |
| R2680 | CHIP RES. 1/10W J 27k Ω | RRXAJR5Z0273 |

| Ref. No. | Description | Part No. |
|----------------------|---------------------------------------|--------------|
| MISCELLANEOUS | | |
| 2L055 | SCREW S-TIGHT M3X8 BIND HEAD+ | GBJS3080 |
| AC1002▲ | AC INLET 0P YKE31-0149N | JTDC0L0JC001 |
| B47 | HEAT SINK E2A00JD | 1VM424636E |
| F1001▲ | FUSE TIME RAG FSL 250V 2A(EM) | PDGJAB0NG202 |
| FH1001 | FUSE HOLDER MSF-015 LF (B110) | XH01Z00LY002 |
| FH1002 | FUSE HOLDER MSF-015 LF (B110) | XH01Z00LY002 |
| JK2100 | RCA JACK(BLACK) MSP-251V-01 NI FE LF | JXRL010LY125 |
| JK2200 | PIN JACK 3P MSD-243V-48 NI FE LF | JXRL030LY167 |
| JK2300 | RCA JACK 3PIN MSD-243V-18 NI FE LF | JXRL030LY132 |
| JK2400 | FIBER OPTIC TRANS.MODULE OC-0805T*002 | JWHHA00JD002 |
| JP2201 | PCB JUMPER D0.6-P7.0 | JW7.0T |
| JP2204 | PCB JUMPER D0.6-P25.0 | JW25.0T |
| JP2208 | PCB JUMPER D0.6-P8.5 | JW8.5T |
| JP2209 | PCB JUMPER D0.6-P24.0 | JW24.0T |
| JP2210 | PCB JUMPER D0.6-P28.0 | JW28.0T |
| JP2211 | PCB JUMPER D0.6-P13.0 | JW13.0T |
| JP2213 | PCB JUMPER D0.6-P13.0 | JW13.0T |
| JP2215 | PCB JUMPER D0.6-P8.0 | JW8.0T |
| JP2216 | PCB JUMPER D0.6-P5.0 | JW5.0T |
| JP2217 | PCB JUMPER D0.6-P5.0 | JW5.0T |
| JP2219 | PCB JUMPER D0.6-P15.0 | JW15.0T |
| JP2222 | PCB JUMPER D0.6-P27.5 | JW27.5T |
| JP2225 | PCB JUMPER D0.6-P25.0 | JW25.0T |
| JP2226 | PCB JUMPER D0.6-P13.0 | JW13.0T |
| JP2227 | PCB JUMPER D0.6-P10.5 | JW10.5T |
| JP2228 | PCB JUMPER D0.6-P17.0 | JW17.0T |
| JP2229 | PCB JUMPER D0.6-P5.0 | JW5.0T |
| SA1001▲ | VARIATOR 10D 471K SVR | NVQZVR10D471 |
| T1001▲ | TRANS POWER 8733 | LTT2PCOKT050 |
| X2000 | CERAMIC RESONATOR ZTT8.00MT47 | FY0805PLN004 |

RS232C CBA

| Ref. No. | Description | Part No. |
|--------------------|--|--------------|
| | RS232C CBA Consists of the following: | 1VSA22030 |
| CAPACITORS | | |
| C5500 | CHIP CERAMIC CAP.(1608) B K 0.1μF/50V | CHD1JK30B104 |
| C5501 | CHIP CERAMIC CAP.(1608) B K 0.1μF/50V | CHD1JK30B104 |
| C5502 | CHIP CERAMIC CAP.(1608) B K 0.1μF/50V | CHD1JK30B104 |
| C5503 | CHIP CERAMIC CAP.(1608) B K 0.1μF/50V | CHD1JK30B104 |
| C5504 | CHIP CERAMIC CAP.(1608) B K 0.1μF/50V | CHD1JK30B104 |
| C5505 | ELECTROLYTIC CAP. 47μF/16V/M | CEC47RENW016 |
| C5506 | ELECTROLYTIC CAP. 47μF/16V/M | CEC47RENW016 |
| C5550 | CHIP CERAMIC CAP.(1608) B K 0.022μF/50V | CHD1JK30B223 |
| C5553 | ELECTROLYTIC CAP. 100μF/10V/M | CEB101ENW016 |
| CONNECTORS | | |
| CN5500 | CONNECTOR KAKU MES J 09 R DBR40-091F200 | JBDB090JD001 |
| CN5501 | PH CONNECTOR SIDE 5P S5B-PH-K-S(LF)(SN) | J3PHC05JG030 |
| ICS | | |
| IC5500 | IC RS232C DRIVER SP232ACN-L/TR | NSZBA0T0D004 |
| IC5550 | PHOTOCOUPLER PS2561A-1(W) | QPEWPS2561A1 |
| COILS | | |
| L5500 | CHIP BEAD GZ1608D121T(F) | XL06001SSN04 |
| L5501 | CHIP BEAD GZ1608D121T(F) | XL06001SSN04 |
| TRANSISTORS | | |
| Q5551 | NPN TRANSISTOR RES.-IN SRC1206M-AT | NQSZSRC1206M |
| Q5552 | NPN TRANSISTOR RES.-IN SRC1206M-AT | NQSZSRC1206M |
| RESISTORS | | |
| R5502 | CHIP RES. 1/10W J 1k Ω | RRXAJR5Z0102 |

| Ref. No. | Description | Part No. |
|----------------------|---------------------------------|--------------|
| R5503 | CHIP RES. 1/10W J 2k Ω | RRXAJR5Z0202 |
| R5551 | CHIP RES. 1/10W J 10k Ω | RRXAJR5Z0103 |
| R5552 | CHIP RES. 1/10W J 10k Ω | RRXAJR5Z0103 |
| R5553 | CHIP RES. 1/10W J 3.3k Ω | RRXAJR5Z0332 |
| R5554 | CHIP RES. 1/10W J 100 Ω | RRXAJR5Z0101 |
| MISCELLANEOUS | | |
| JK5550 | PHONE JACK MSJ-20000B AG | JXSL020LY003 |

FRONT ASSEMBLY

| Ref. No. | Description | Part No. |
|----------|--|-----------|
| | FRONT ASSEMBLY Consists of the following: | 1VSA22025 |
| | FRONT CBA | ----- |
| | POWER SW CBA | ----- |

FRONT CBA

| Ref. No. | Description | Part No. |
|----------------------|---|--------------|
| | FRONT CBA Consists of the following: | ----- |
| CAPACITORS | | |
| C3000 | CHIP CERAMIC CAP,(1608) F Z 0.1 μ F/50V | CHD1JZ30F104 |
| C3001 | ELECTROLYTIC CAP. 22 μ F/50V/MH7 | CEF22RENW025 |
| C3002 | CHIP CERAMIC CAP,(1608) F Z 0.1 μ F/50V | CHD1JZ30F104 |
| C3003 | ELECTROLYTIC CAP. 100 μ F/6.3V/MH7 | CEA101ENW025 |
| C3005 | CHIP CERAMIC CAP,(1608) B K 1000pF/50V | CHD1JK30B102 |
| C3006 | CHIP CERAMIC CAP,(1608) F Z 0.1 μ F/50V | CHD1JZ30F104 |
| C3007 | ELECTROLYTIC CAP. 100 μ F/6.3V/MH7 | CEA101ENW025 |
| C3008 | CHIP CERAMIC CAP,(1608) B K 0.1 μ F/50V | CHD1JK30B104 |
| CONNECTORS | | |
| CN3000 | WIRE ASSEMBLY FRONT-AV 16P WX1E5K10-002 | WX1E5K10-002 |
| CN3001 | CONNECTOR PRINT OSU S3B-PH-K-S(LF)(SN) | J3PHC03JG030 |
| COIL | | |
| L3001 | CHIP INDUCTOR LB 2016T101K | LLC101KTU007 |
| TRANSISTOR | | |
| Q3000 | NPN TRANSISTOR SMD 2SC5343SFG | NQ1G2SC5343S |
| RESISTORS | | |
| R3000 | CHIP RES. 1/10W J 10 Ω | RRXAJR5Z0100 |
| R3001 | CHIP RES. 1/10W J 10 Ω | RRXAJR5Z0100 |
| R3002 | CHIP RES. 1/10W J 12k Ω | RRXAJR5Z0123 |
| R3003 | CHIP RES.(1608) 1/10W 0 Ω | RRXAZR5Z0000 |
| R3004 | CHIP RES. 1/10W J 1k Ω | RRXAJR5Z0102 |
| R3005 | CHIP RES. 1/10W J 150 Ω | RRXAJR5Z0151 |
| R3012 | CHIP RES. 1/10W J 180 Ω | RRXAJR5Z0181 |
| R3014 | CHIP RES. 1/10W J 6.8k Ω | RRXAJR5Z0682 |
| R3015 | CHIP RES. 1/10W J 220 Ω | RRXAJR5Z0221 |
| R3019 | CHIP RES. 1/10W J 330 Ω | RRXAJR5Z0331 |
| R3020 | CHIP RES. 1/10W J 5.1k Ω | RRXAJR5Z0512 |
| SWITCHES | | |
| SW3003 | TACT SWITCH SKQSAB | SST0101AL038 |
| SW3004 | TACT SWITCH SKQSAB | SST0101AL038 |
| SW3005 | TACT SWITCH SKQSAB | SST0101AL038 |
| SW3006 | TACT SWITCH SKQSAB | SST0101AL038 |
| MISCELLANEOUS | | |
| B70 | TAPE HIMERON(60*6) HG470ED | 1VM421170 |
| FL3000 | FL DM182-GINK | TVFD150FT018 |
| RS3000 | PHOTO LINK MODULE KSM-713TH2P | USESJR5K061 |

POWER SW CBA

| Ref. No. | Description | Part No. |
|----------------------|--|--------------|
| | POWER SW CBA Consists of the following: | ----- |
| DIODE | | |
| D3007 | LED(RED) LTL-1CHEE | NPQZLTL1CHEE |
| SWITCH | | |
| SW3007 | TACT SWITCH SKQSAB | SST0101AL038 |
| MISCELLANEOUS | | |
| WX3000 | WIRE ASSEMBLY FRONT-SWITCH 3P WIRE WX1E5K50-001 | WX1E5K50-001 |

SD ASSEMBLY

| Ref. No. | Description | Part No. |
|----------|---|-----------|
| | SD ASSEMBLY Consists of the following: | 1VSA20906 |
| | SD-A CBA | ----- |
| | SD-B CBA | ----- |
| | SD-C CBA | ----- |

SD-A CBA

| Ref. No. | Description | Part No. |
|-------------------|--|--------------|
| | SD-A CBA Consists of the following: | ----- |
| CAPACITOR | | |
| C4008 | CHIP CERAMIC CAP,(1608) CH J 33pF/50V | CHD1JJ3CH330 |
| CONNECTORS | | |
| CN4001 | B TO B CONNECTOR 16P SOKET 131101116K2 | J313160TG001 |
| CN4003 | 242 SERIES CONNECTOR TUC-P15X-B1 WHT ST | JCTUB15TG002 |
| COILS | | |
| L4002 | CHIP INDUCTOR LK160882NM-T | LLACMB3TU82N |
| L4008 | CHIP RES.(1608) 1/10W 0 Ω | RRXAZR5Z0000 |
| RESISTORS | | |
| R4001 | CHIP RES. 1/10W J 47 Ω | RRXAJR5Z0470 |
| R4002 | CHIP RES. 1/10W J 47 Ω | RRXAJR5Z0470 |
| R4003 | CHIP RES. 1/10W J 47 Ω | RRXAJR5Z0470 |
| R4004 | CHIP RES. 1/10W J 22 Ω | RRXAJR5Z0220 |
| R4005 | CHIP RES. 1/10W J 47 Ω | RRXAJR5Z0470 |
| R4006 | CHIP RES. 1/10W J 47 Ω | RRXAJR5Z0470 |

SD-B CBA

| Ref. No. | Description | Part No. |
|-------------------|--|--------------|
| | SD-B CBA Consists of the following: | ----- |
| CONNECTORS | | |
| CN4101 | 242 SERIES CONNECTOR 224202115W1 | J322C15TG001 |
| CN4102 | 242 SERIES CONNECTOR 224202115W1 | J322C15TG001 |

SD-C CBA

| Ref. No. | Description | Part No. |
|-------------------|---|--------------|
| | SD-C CBA Consists of the following: | ----- |
| CAPACITORS | | |
| C4001 | CHIP CERAMIC CAP,(1608) B K 0.1 μ F/16V | CHD1CK30B104 |
| C4002 | CHIP CERAMIC CAP,(2125) B K 10 μ F/6.3V | CHE0K30B106 |
| CONNECTORS | | |
| CN4002 | CONNECTOR IC CARD MES 9PIN 1939115-1 | JF18090AP001 |
| CN4004 | 242 SERIES CONNECTOR TUC-P15X-B1 WHT ST | JCTUB15TG002 |
| RESISTOR | | |
| R4022 | CHIP RES.(1608) 1/10W 0 Ω | RRXAZR5Z0000 |

Integra Division of

ONKYO CORPORATION

Service Dept. Technical Support : 2-1, Nisshin-cho, Neyagawa-shi, OSAKA 572-8540, JAPAN

Tel: 072-831-8023 Fax: 072-831-8163 <http://www.onkyo.com/>

Integra Division of

ONKYO U.S.A. CORPORATION

18 Park Way, Upper Saddle River, N.J. 07458, U.S.A.

Tel: 201-785-2600 Fax: 201-785-2650 <http://www.integrahometheater.com>