

## AV Controller

# Service Manual

## DHC-60.7

- ✓ Pre Issue (2015-Aug)
- ✓ Final Issue (2015-Sep)

### CONTENTS

- ✓ [Front Cover \(This page\)](#)
- ✓ [Note for Parts List](#)
- ✓ [Panel](#)
- ✓ [Reset](#)
- ✓ [Amp Diag Mode after Abnormal Conditions](#)
- ✓ [Model and Destination](#)
- ✓ [Firmware](#)
- ✓ [Hookup and Setting](#)
- ✓ [Trouble Shoot](#)
- Disassembly
- ✓ [Schematic Diagram](#)
- ✓ [Exploded View](#)
- ✓ [Appendix](#)

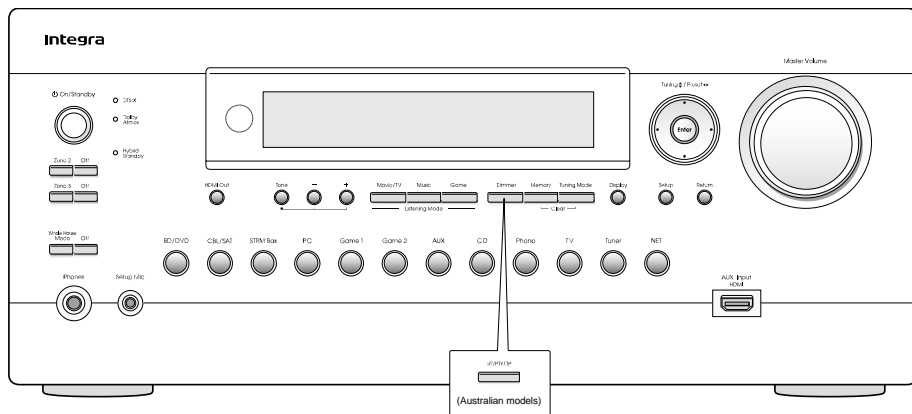

**SAFETY-RELATED COMPONENT WARNING!!** : COMPONENTS IDENTIFIED BY MARK  ON THE SCHEMATIC DIAGRAM AND IN THE PARTS LIST ARE CRITICAL FOR RISK OF FIRE AND ELECTRIC SHOCK. REPLACE THESE COMPONENTS WITH ONKYO PARTS WHOSE PART NUMBERS APPEAR AS SHOWN IN THIS MANUAL. MAKE LEAKAGE-CURRENT OR RESISTANCE MEASUREMENTS TO DETERMINE THAT EXPOSED PARTS ARE ACCEPTABLY INSULATED FROM THE SUPPLY CIRCUIT BEFORE RETURNING THE APPLIANCE TO THE CUSTOMER.

# Integra®

Published by Onkyo & Pioneer Corporation Global CS Department

# File Name of Parts List File (EXCEL File)

## Note for Parts List

When parts list is EXCEL file, please refer to the following explanation about file name.

PL\_ **TX-SR343** ( **B** ) **MJJ** .xlsx

**Model No.**

**Color**

**Destination**

Look at the rear panel serial number 6 digit.

○ ○ ○ ○ ○ J ○ ○ ○ ○ ○ ○ ○ ○ ○ ○ ○

**Voltage**

Look at the rear panel serial number 5 digit.

○ ○ ○ ○ J ○ ○ ○ ○ ○ ○ ○ ○ ○ ○ ○

**Color**

- (B) Black
- (BR) Brown
- (C) Cherry
- (G) Gold
- (GR) Green
- (H) Gray
- (K) Black
- (L) Blue
- (LB) Light Blue
- (M) Wood
- (O) Orange
- (P) Pink
- (R) Red
- (S) Silver
- (V) Violet
- (W) White
- (Y) Yellow

**Voltage**

- J 100V AC
- D 120V AC
- G 220~230V
- H 220~230/240V
- M 220~240V AC
- P 230V AC
- U 100~240V AC
- V 110~240V
- W 120V/220~240V

**Destination**

- J Japan
- C North American
- D USA
- F Taiwan
- S Brazil
- Q Hong Kong
- R China
- A Australia
- B United Kingdom
- K Korea
- L Russia
- P Europe
- U Worldwide

**Speaker System (without AMP.) :**

- L Left channel
- R Right channel
- 0 Center channel

**Speaker System (without AMP.) :**

- 0 Passive Subwoofer
- F Front Speaker
- C Center Speaker
- R Rear Speaker
- B Back Speaker

Front Panel

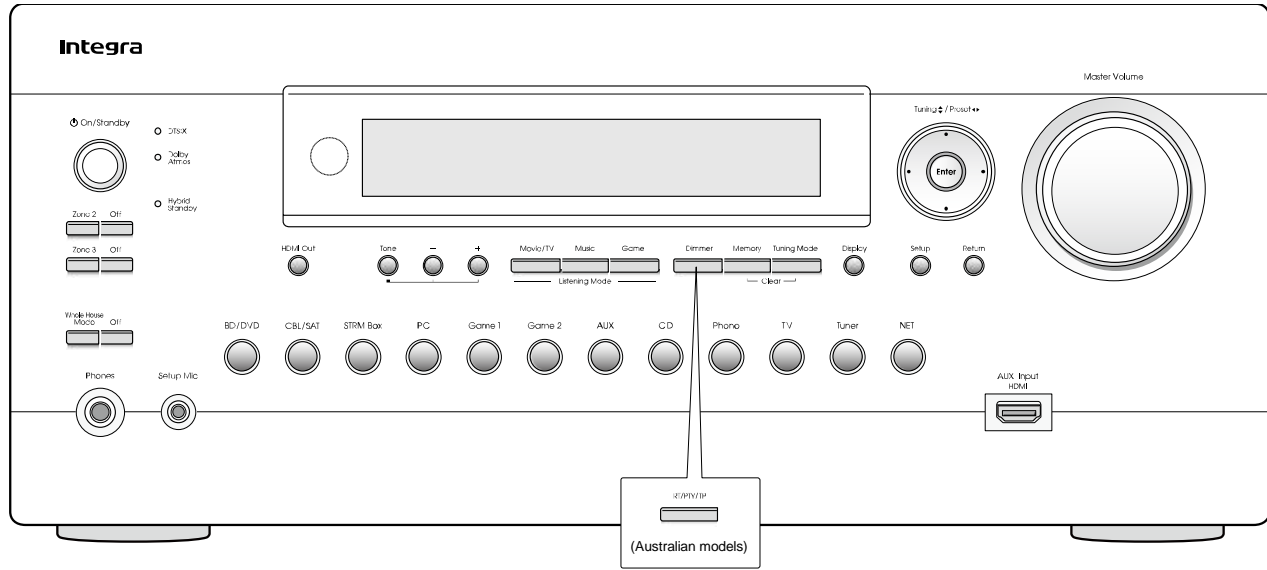

Remote Control Unit  
RC-901M

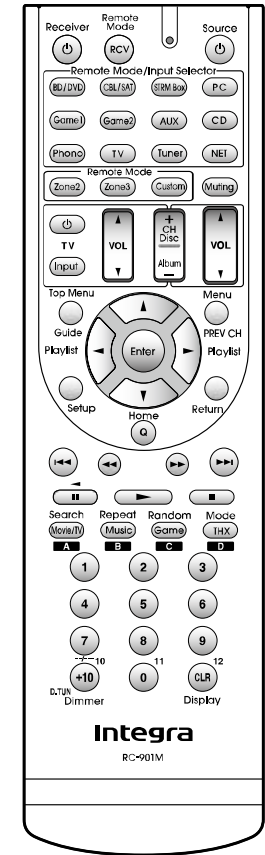

Rear Panel

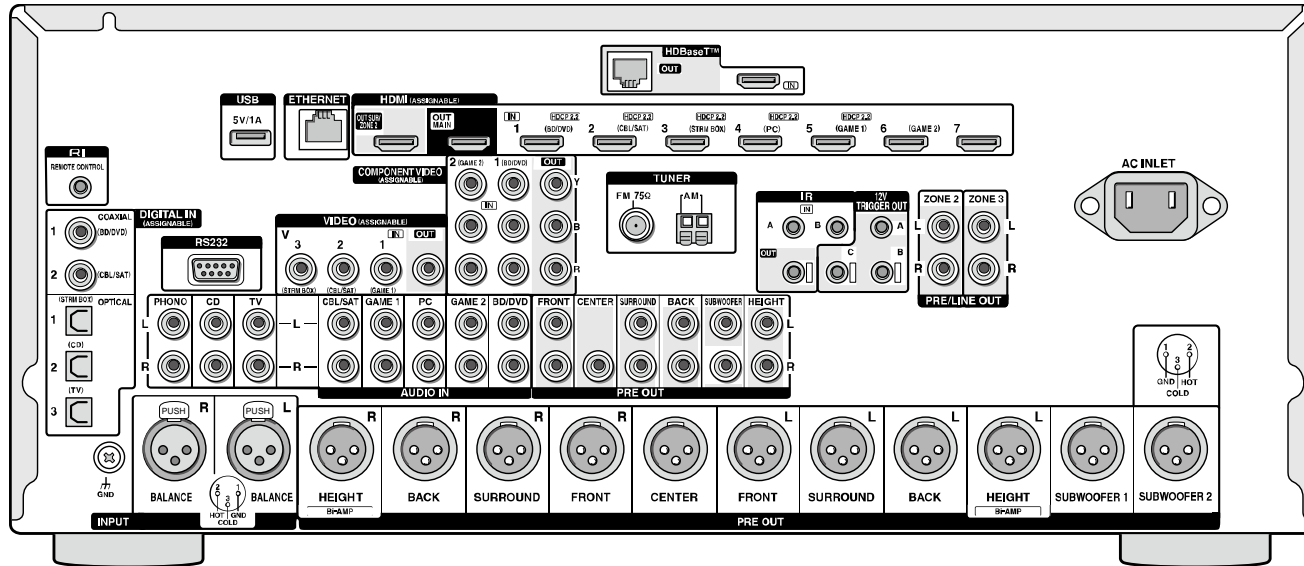

Dimensions (W × H × D) : 435 mm × 199 mm × 416 mm, 17-1/8" × 7-13/16" × 16-3/8"  
Weight : 12 kg (26.5 lbs.)

Accessory

- Indoor FM antenna --- (1)
- AM loop antenna --- (1)
- Remote controller (RC-901M) --- (1)
- Batteries (AA/R6) --- (2)
- Power cord --- (1)
- Speaker setup microphone --- (1)

\* The number in parenthesis indicates the quantity.  
On packaging, the letter at the end of the product name indicates the color.

# How to Reset the Unit

## Reset

### ● How to reset:

#### Step1

While holding down CBL/SAT on the main unit (note that step 2 must be performed with this button pressed down)

#### Step2

Press ON/STANDBY on the main unit. ("Clear" appears on the display and the unit returns to standby.)

- Do not unplug the power cord until "Clear" disappears from the display.

### ● How to reset the remote controller:

#### Step1

While holding down RCV on the remote controller, press Q until the remote indicator stays lit (about 3 seconds).

#### Step2

Within 30 seconds, press RCV again.

### ● リセット方法 :

#### 1.

本体のCBL/SATボタンを押しながら（必ず押した状態で2.の操作を行ってください）

#### 2.

本体のON/STANDBYボタンを押す（表示部に「Clear」が表示されてスタンバイ状態に戻ります）

- 表示部から「Clear」が消えるまで、絶対に電源コードを抜かないでください。

### ● リモコンのリセット方法 :

#### 1.

リモコンのRCVボタンを押しながら、リモートインジケータが点灯するまでQボタンを3秒以上押す

#### 2.

30秒以内にRCVボタンをもう一度押すとリセットされる

# Protect Mode

# Amp Diag Mode after Abnormal Conditions

The unit goes into standby automatically when detect the abnormal condition of thermal detection, dc voltage detection or current detection. (e.g. TX-SR343 block diagram below)

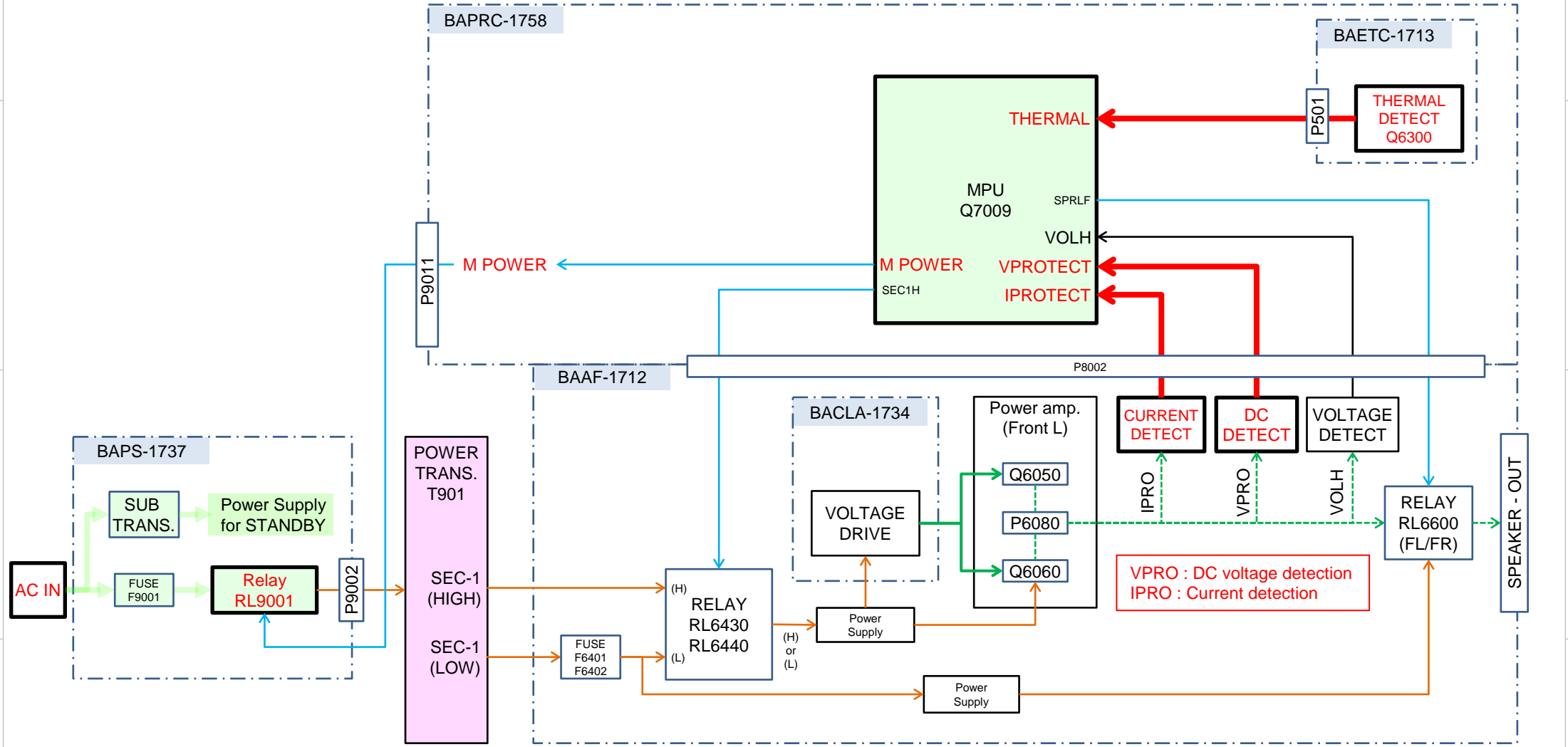

# Self-diagnostics

This function is for avoiding the rupture of electrolytic capacitors with amplifier circuit failure during power-ON.

## Operation of Self-diagnostic

Self-diagnostic will start at the timing of next power on, after goes to the protect mode by Current detection or DC voltage detection.

Only On/Standby key could work in this mode. Also remote control does not work. However, the CLEAR operation is enabled.

During Self-diagnostic, the power supply for amplifier circuit become low voltage state(SEC1-LOW), and the speaker relay will be turned off. Then, MPU will check each amplifier circuits Internally by entering the test signal (20 kHz,-20 dBFS sine wave) to each channel from DSP.

MPU will judge the amplifier circuit is good or not from VOLH value.

The normal range of VOLH value is  $0.04\text{ V} < \text{VOLH} < 0.20\text{ V}$ .

If VOLH value is in the out of this range, it will be judged as NG (No good).

## No problem found

When protected by current detection, and no problem found, "CHECK SP WIRE" will be displayed. In this State, Only the On/Standby key is effective. And if do not anything for 3 minutes, unit goes into standby automatically.

When protected by a DC voltage detection, and no problem found, unit goes into normal operation.

## Problem found

When judged as there is a problem on any channel, the information of channel that has a problem will be displayed as in the right figure.

In this State, Only the On/Standby key is effective. Also remote control does not work. If do not anything for 3 minutes, unit goes into standby automatically. This state will keep also after unit turn on/off, or AC unplugged.

the power supply for amplifier circuit become low voltage state(SEC1-LOW), and the speaker relay will be turned off.

# Amp Diag Mode after Abnormal Conditions

Display of during Self-diagnostics

2 Line FL tube type

A	M	P		D	i	a	g		M	o	d	e	

1 Line FL tube type

A	M	P		D	i	a	g		M	o	d	e	
---	---	---	--	---	---	---	---	--	---	---	---	---	--

"Mode" This part display the channel which is currently checked. (E.g. "[FL]", etc.)

Display of when problem found

2 Line FL tube type

N	G		C	H	:								
			L	C	R	S	L	S	R	B	L	B	R

1 Line FL tube type

N	G	:	L	C	R	S	L	S	R	B	L	B	R
---	---	---	---	---	---	---	---	---	---	---	---	---	---

- L** → Front L channel      **S L** → Surround L channel
- C** → Center channel      **S R** → Surround R channel
- R** → Front R channel      **B L** → Surround back L channel
- B R** → Surround back R channel

# Repair Process and How to Confirm

## Confirmation of the protect cause

While NG channel is displayed, You can confirm the protect cause by following the step below.

1. Press the Enter button
2. The protect cause are displayed for 5 seconds.

Please check the around of those amplifier circuit and repair it.

## Clear of NG CH information

After repair, you can clear NG CH information by following the steps below.

1. Press the On/Standby key while pressing the Enter key.
2. Display as in the right figure appears.
3. Unit goes into Standby automatically after 5 seconds.

Self-diagnostic will start again at the timing of next power on.

By this, You can verify whether repair was properly or not.

If problem found after repair, please re-check the around of its circuit.

## Cancel of Self-diagnostic

You can cancel this mode by clear operation (press Standby key while pressing CBL/SAT key).

After cancel this mode, receiver will be started as normal operation.

# Amp Diag Mode after Abnormal Conditions

Protected by current detection

D E T . P R O T E C T : I

Protected by DC Voltage detection

D E T . P R O T E C T : V

Clear of NG CH information

N G C H C L E A R

# How to check model and destination

# Model and Destination

[TV] + [ON/STANDBY] → [DIMMER] or [RT/PTY/TP] → [TONE +] x 4

Model Name	Voltage	Destination	FL Display														
			R	Z	8	0	0			D	C			2	0	0	0
TX-RZ800	D	C	R	Z	8	0	0			D	C			2	0	0	0
TX-RZ800	J	J	R	Z	8	0	0			J	J			4	0	0	0
TX-RZ800	X	X	R	Z	8	0	0			x	x			8	0	0	0
DTR-50.7	D	D	D	T	R	5	0	7		D	D			2	0	4	0
DTR-50.7	X	X	D	T	R	5	0	7		x	x			8	0	4	0
TX-RZ900	D	C	R	Z	9	0	0			D	C			2	2	0	0
TX-RZ900	X	X	R	Z	9	0	0			x	x			8	2	0	0
DTR-60.7	D	D	D	T	R	6	0	7		D	D			2	2	4	0
DTR-60.7	X	X	D	T	R	6	0	7		x	x			8	2	4	0
DHC-60.7	D	D	D	H	C	6	0	7		D	D			2	2	8	0
DHC-60.7	X	X	D	H	C	6	0	7		x	x			8	2	8	0



# How to check Firmware Version & Preparation of Update

### Step1 : [DISPLAY] + [ON/STANDBY] x 2

Main Firmware Version will appear on the main unit's display.

### Step2 : [TONE +1]

NET Firmware Version will appear on the main unit's display.

### Step3 : [TONE +2]

DSP Firmware Version will appear on the main unit's display.

### Step4 : [TONE +3]

Video Firmware Version will appear on the main unit's display.

### Step3 : [TONE +4]

OSD Firmware Version will appear on the main unit's display.

### Step4 : [TONE +5 over]

Return to Display Main Firmware Version ( Return Step1)

Firmware Version will appear momentaly on the main unit's display.

### [Preparation of Update]

1. Connect the USB storage device to your PC. If there is any data in the USB storage device, remove it.
2. Download the firmware file (package file) from the Onkyo FTP-server. However European service partners should download the firmware file (package file) from the ExtraNet.

Onkyo FTP-server: <ftp://manex.onkyo.co.jp/>

ID and Password are those we informed when changed.

Filename is as follows: ONKAVR0001\*\*\*\*\*.zip

Unzip the downloaded file. A following file is created.

ONKAVR0001\*\*\*\*\*.of0

ONKAVR0001\*\*\*\*\*.of1

ONKAVR0001\*\*\*\*\*.of2

ONKAVR0001\*\*\*\*\*.of3

ONKAVR0001\*\*\*\*\*.of4

ONKAVR0001\*\*\*\*\*.of5

ONKAVR0001\*\*\*\*\*.of6

3. Copy it to the USB storage device. Be careful not to copy the zip file.
4. Remove the USB storage device from your PC.

# How to Update (service mode) 1/2

## Firmware

Overwriting is also possible.

1. Connect the USB storage to the USB port on the unit.



2. Turn on the unit. It takes some time to start after you switch on the unit.  
Press: [DISPLAY] + [ON/STANDBY] x 2
3. Press [RETURN] button, Then it is displayed as below



If you need each module of the firmware update, you can select the module by pressing PRESET < and > button.

If you need change source NET or USB, you can select the source by pressing TUNING UP and Down key

It should be updated firmware by selecting USB -> ALL normally.

- USB -> ALL: ALL firmware update ( default )
- USB -> DSP: DSP firmware update
- USB -> OSD: OSD firmware update
- USB -> VMPU: VMPU firmware update
- USB -> DA830: DA830 firmware update
- USB -> MMPU: Main MPU firmware update
- USB -> WORK: Compare between AVR and USB, Only update new version firmware

- NET -> ALL: ALL firmware update ( default )
- NET -> DSP: DSP firmware update
- NET -> OSD: OSD firmware update
- NET -> VMPU: VMPU firmware update
- NET -> DA830: DA830 firmware update
- NET -> MMPU: Main MPU firmware update
- NET -> WORK: Compare between AVR and MMC,  
Only update new version firmware by network

The default setting is " ALL "



**CAUTION: When you will update each module firmware, you have to keep combination of firmware.**

## How to Update (service mode) 2/2

## Firmware

4. Press [ENTER] button. Start update firmware.



5. Wait until update is completed. When the update ends, "Completed!" is displayed. When "Completed!" message appeared, you can power off by pressing "ON/STANDBY" button. (If you leave it, it automatically turns standby mode.)



6. Press [ON/STANDBY] button, and the unit turns on.

7. Check the new FW version number.

<Note>

If the procedure might not be successful, please select "USB -> ALL".

# No Sound

### ■ No sound from connected player

- Chose input selector which is assigned to connected input terminal ?
- Isn't muting on ?

### ■ No sound from connected TV

- Chose wrong input selector ?
- Connect to this model's HDMI OUT terminal from TV by HDMI cable ?
- When TV supports ARC function, connect to his model's HDMI OUT terminal from TV's HDMI input terminal for ARC function ?
- When TV doesn't support ARC function, connect TV to this model with optical cable etc. ?
- Isn't muting on ?

### ■ No sound from some connected loudspeaker(s)

- No sound loudspeaker(s) config is enabled ?

### ■ No sound from all connected TV or Blu-ray player etc.

- After chose loudspeaker volume level setting, test tone is OK ?

### ■ No problem about above items

- Unplug power cord  
After 10 seconds, connect power cord again
- Reset this model

# No Picture

## Hookup and Setting

### ■ In general

- Connection cable is bent , twisted or damaged ?
- Input is switched on TV ?

### ■ No picture from connected player by HDMI input terminal

- Chose input selector which is connected to player ?
- Listening mode is not Pure Audio ?
- Don't use HDMI-DVI adaptor. From personal computer ?

### ■ No picture from connected player by component video terminal

- Output to TV connected to component video out terminal from player's picture connected to the composite video input terminals ?

### ■ No problem about above items

- Unplug power cord  
After 10 seconds, connect power cord again
- Reset this model

# No Power

## Hookup and Setting

### ■ In general

Doesn't be connection cable bent, be it twisted and be it damaged?

### ■ There is time when indication on the front panel doesn't just light up.

Please check the connecting cord of a DISPLAY PCB.

### ■ No problem about above items

Unplug power cord

After 10 seconds, connect power cord again

Reset this model

# No Picture (HDMI in/ out)

Here the trouble shoot which focuses on the hardware troubles regarding PCB assembly is explained.  
Of course, with actual repair there are also troubles due to damaged Power Transformer, Wiring, soldering etc. in addition to PCB assembly.

このトラブルシューティングは故障している基板を特定するためのものです。  
ここで見つかった故障基板だけが原因ではなく、電源トランス・接続線の結線・はんだ付けなどの不具合も考えられます

## Trouble Shoot

Process	Check Point	Damaged PCB
1	<b>P2200B</b> (BAPRC-1802) ● No.1 pin or 7 pin : +15V	BAVD-1798
2		BAPRC-1802

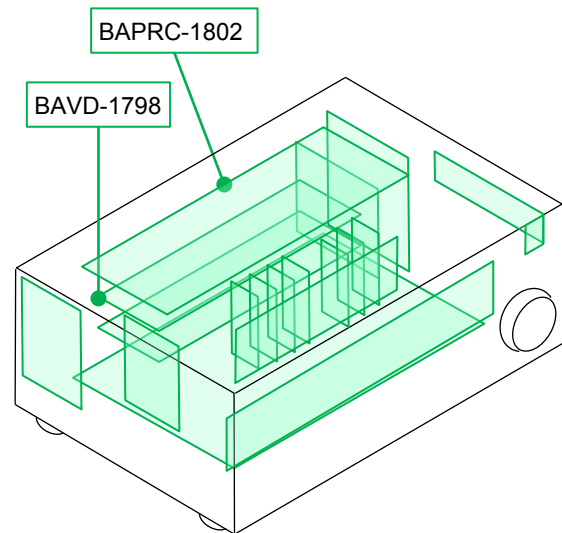

● Each voltage is shown as the reference value.  
● 各電圧は実測した標準値です

# No Picture (Component in/ HDMI out)

Here the trouble shoot which focuses on the hardware troubles regarding PCB assembly is explained.  
Of course, with actual repair there are also troubles due to damaged Power Transformer, Wiring, soldering etc. in addition to PCB assembly.

このトラブルシューティングは故障している基板を特定するためのものです。  
ここで見つかった故障基板だけが原因ではなく、電源トランス・接続線の結線・はんだ付けなどの不具合も考えられます

## Trouble Shoot

Process	Check Point		Damaged PCB
1	<b>P2200B</b> (BAPRC-1802) ● No.1 pin or 7 pin : +15V	No Good → OK ↓	BAVD-1798
2	<b>P2200B</b> (BAPRC-1802) ● No.3 pin or 5 pin : +5V	No Good → OK ↓	BAPRC-1802
3	<b>P2201B</b> (BAPRC-1802) ● No.12 pin : Check signal ● No.14 pin : Check signal ● No.16 pin : Check signal	No Good → OK ↓	BAVD-1798
4		→	BAPRC-1802

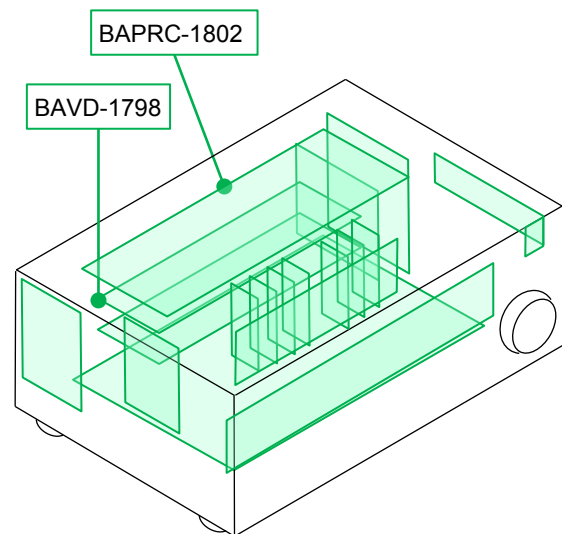

● Each voltage is shown as the reference value.  
● 各電圧は実測した標準値です



# No Picture (Composite in/ HDMI out)

Here the trouble shoot which focuses on the hardware troubles regarding PCB assembly is explained.  
Of course, with actual repair there are also troubles due to damaged Power Transformer, Wiring, soldering etc. in addition to PCB assembly.

このトラブルシューティングは故障している基板を特定するためのものです。  
ここで見つかった故障基板だけが原因ではなく、電源トランス・接続線の結線・はんだ付けなどの不具合も考えられます

## Trouble Shoot

Process	Check Point	Damaged PCB
1	<b>P2200B</b> (BAPRC-1802) ● No.1 pin or 7 pin : +15V	No Good → BAVD-1798 OK ↓
2	<b>P2200B</b> (BAPRC-1802) ● No.3 pin or 5 pin : +5V	No Good → BAPRC-1802 OK ↓
3	<b>P2201B</b> (BAPRC-1802) ● No.16 pin : Check signal	No Good → BAVD-1798 OK ↓
4		→ BAPRC-1802

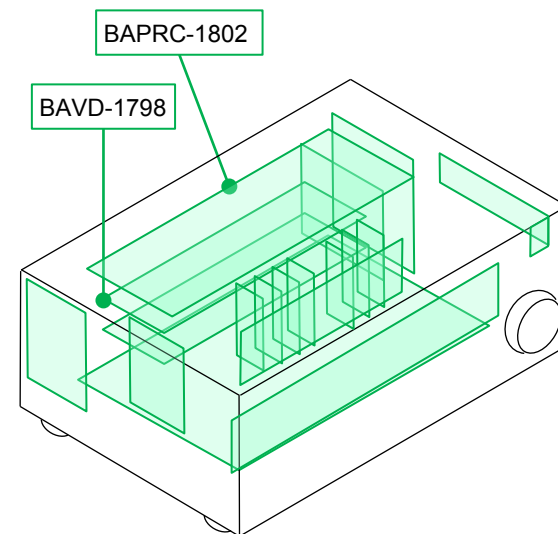

● Each voltage is shown as the reference value.  
 ● 各電圧は実測した標準値です

# No Power

# Trouble Shoot

Here the trouble shoot which focuses on the hardware troubles regarding PCB assembly is explained.  
Of course, with actual repair there are also troubles due to damaged Power Transformer, Wiring, soldering etc. in addition to PCB assembly.

このトラブルシューティングは故障している基板を特定するためのものです。  
ここで見つかった故障基板だけが原因ではなく、電源トランス・接続線の結線・はんだ付けなどの不具合も考えられます

Process	Check Point	Damaged PCB
1	<b>F9001</b> (BAPS-1781(TX/DTR-)/BAPS-1807(DHC-)) ● : AC100V~240V	No Good → BAPS-1781(TX/DTR-) OK → BAPS-1807(DHC-)
2	<b>F9002</b> (BAPS-1781(TX/DTR-)/BAPS-1807(DHC-))	No Good → BAAF-1785(TX/DTR-) OK → BACLA-1746(TX/DTR-) BATRM-1804(DHC-)
3	<b>F6901/6902/6903 *//6904 *</b> (BAPS-1780(TX/DTR-))	No Good → BAAF-1785(TX/DTR-) OK → BACLA-1746(TX/DTR-) BATRM-1804(DHC-)
4	<b>ANY PARTS</b> (BACLA-1787~1793/BAAMP-1779(TX/DTR-))	No Good → BACLA-1787~1793(TX/DTR-) OK → BAAMP-1779(TX/DTR-)
5	<b>P7002(FFC)</b> (BAPRC-1802)	No Good → P7002(FFC) OK →
6	<b>P2200B</b> (BAPRC-1802) ● #1, ● #7(+12VSTB) : +15V	No Good → BAPS-1781(TX/DTR-) OK → BAPS-1807(DHC-)
7	<b>P2201B</b> (BAPRC-1802) ● #20(M_PON) : 0V	No Good → BAPRC-1802 OK →
8	<b>P7000B</b> (BAPRC-1802) ● #3: +5V	No Good → BAPRC-1802 OK →
9	<b>RL9001/9002/9031 *</b> (BAPS-1781(TX/DTR-)/BAPS-1807(DHC-))	No Good → BAPS-1781(TX/DTR-) OK → BAPS-1807(DHC-)
10	<b>P9002 *//P9005</b> (BAPS-1781(TX/DTR-)/BAPS-1807(DHC-)) □ : AC100V~240V	No Good → BAVD-1798 OK →
11	<b>P7002(FFC)</b> (BADIS-2256/1810(TX-)/BADIS-1816(DTR/DHC-))	No Good → P7002(FFC) OK →
12		BADIS-2256/1810(TX-) BADIS-1816(DTR/DHC-)

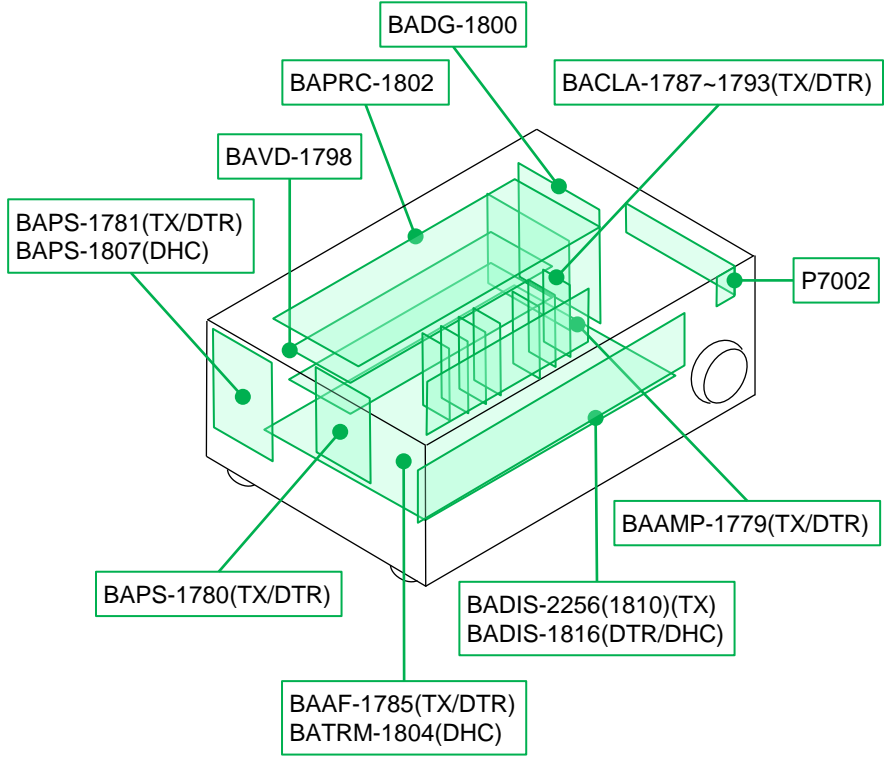

**ANY PARTS on BACLA-1787.../BAAMP-1779**  
Check damage parts  
Normal(OK) or Damage (No good)  
Check the damage in the red framework part as shown with visual inspection.  
e.g. Broken, Burnout, Discoloration, etc.

● Each voltage is shown as the reference value.  
● 各電圧は実測した標準値です

# Check Point (BAPRC-1820)

# Trouble Shoot

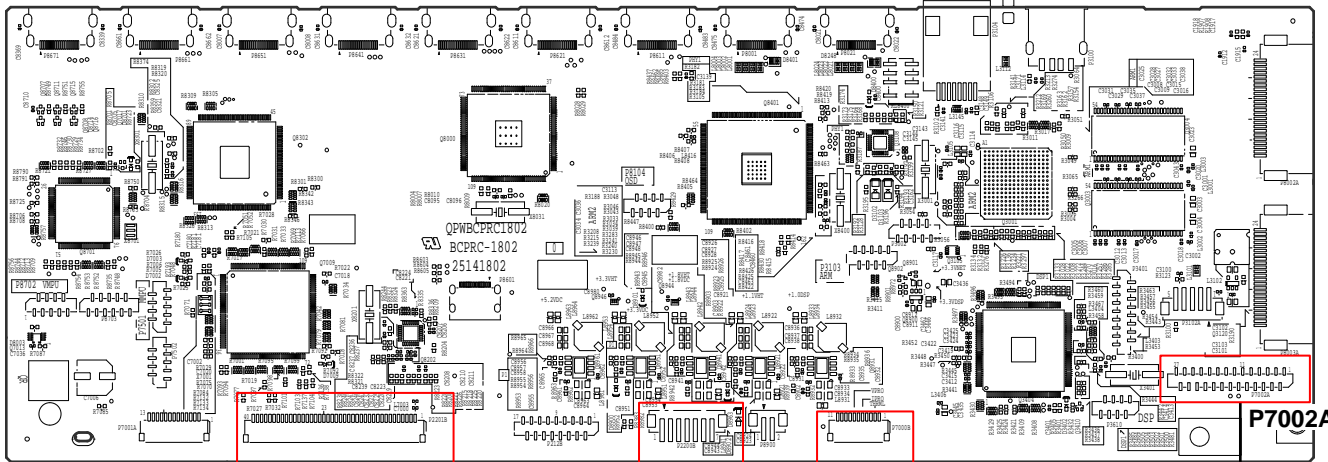

### P2200B

- Check voltage
- No.1 pin or 7 pin : ca. +12V (Stand By), ca. +15V (Power On)
  - No.3 pin or 5 pin : ca. +5V

### P2201B

- Check signal
- No.12 pin : signal
    - Waveform: ca. 1.4V, 64μs
  - No.14 pin : signal
    - Waveform: ca. 1.4V, 64μs

Input signal : Color bar(NTSC)

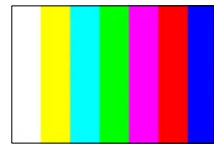

- No.16 pin : signal
  - Waveform: ca. 2.2V, 64μs

- Check voltage
- No.20 pin : ca. 0V

### P7000B

- Check voltage
- No.3 pin : ca. +5V

### P7002(FFC)

- Check damage and connection
- How to check
- 1.Disconnect the FFC from the socket.
  - 2.Check the contacts of the FFC.

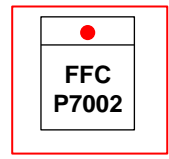
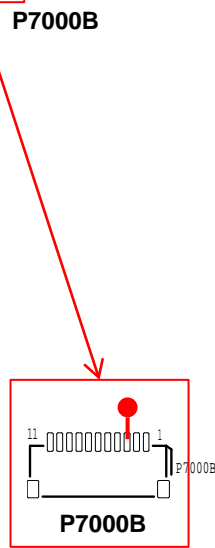
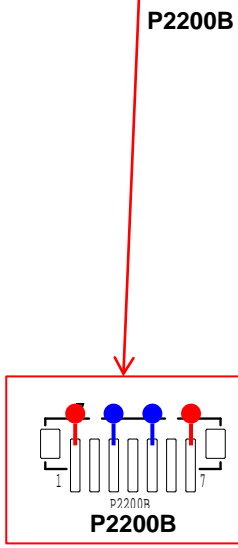
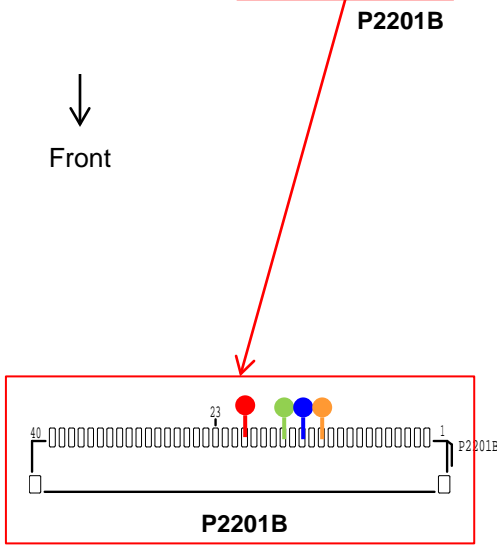

● Each voltage is shown as the reference value.  
● 各電圧は実測した標準値です

Check Point (BAPS-1781(TX/DTR-)/BAPS-1807(DHC-)/BAPS-1780(TX/DTR-))

**Trouble Shoot**

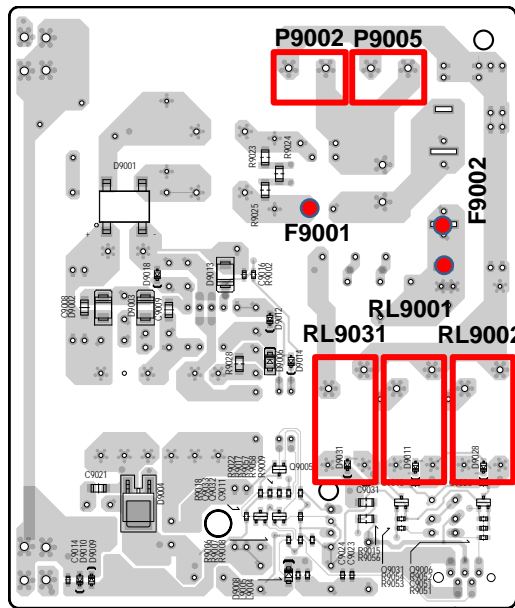

BAPS-1781(TX/DTR-)

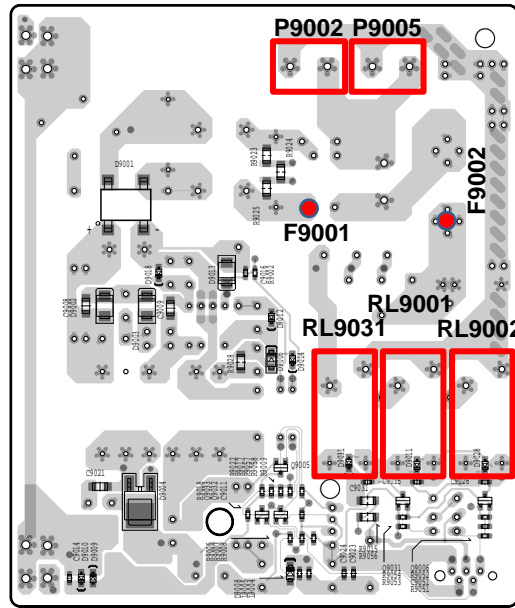

BAPS-1807(DHC-)

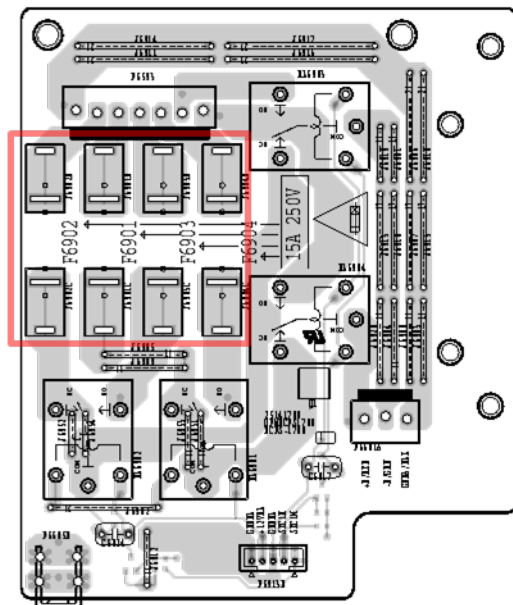

BAPS-1780(TX/DTR-)

- F9001**  
Check voltage  
● : AC100 ~ 240V (Power supply voltage)
- F9002**  
Check voltage  
● : AC100 ~ 240V (Power supply voltage)
- F6901/6902/6903 \* /6904 \***  
Check damage  
● Normal (OK) or blown (No good)
- P9002/9005**  
Check voltage  
□ : AC100 ~ 240V (Power supply voltage)
- RL9001/9002/9031**  
Check operation of a relay by sound.  
□ : No sound at all ----> No good

● Each voltage is shown as the reference value.  
● 各電圧は実測した標準値です

Check Point (BADIS-2256/1810(TX-)/BADIS-1816(DTR/DHC-))

**Trouble Shoot**

- P7002(FFC)**
- Check damage and connection
- How to check
1. Disconnect the FFC from the socket.
  2. Check the contacts of the FFC.

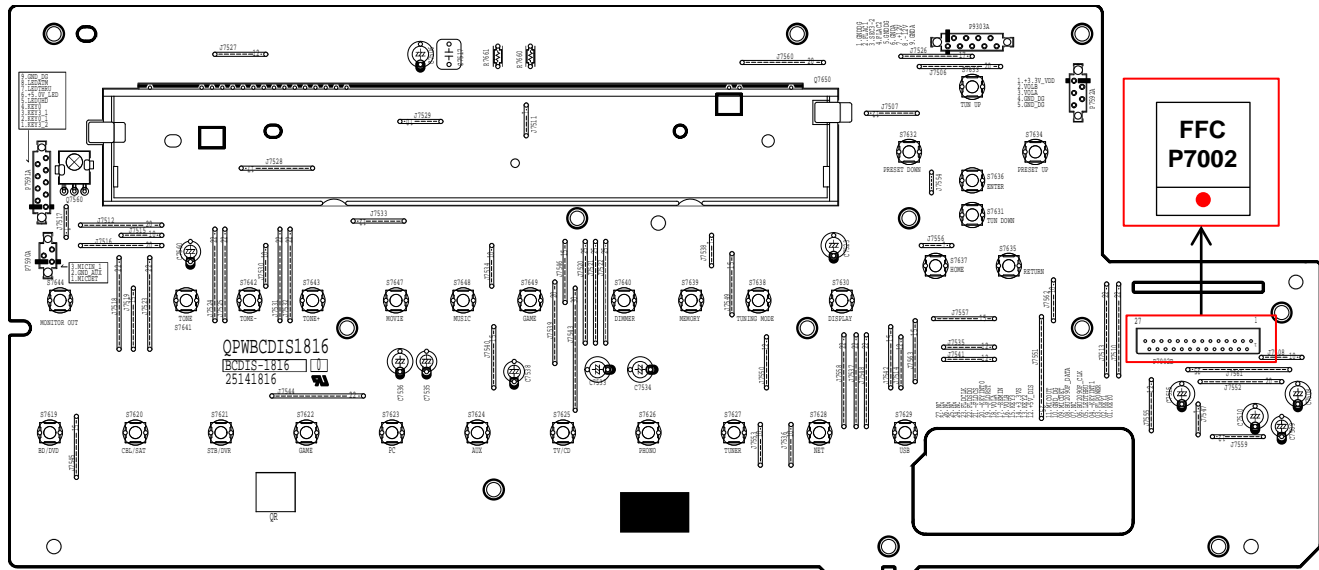

P7002B

BADIS-1816(DTR/DHC-)

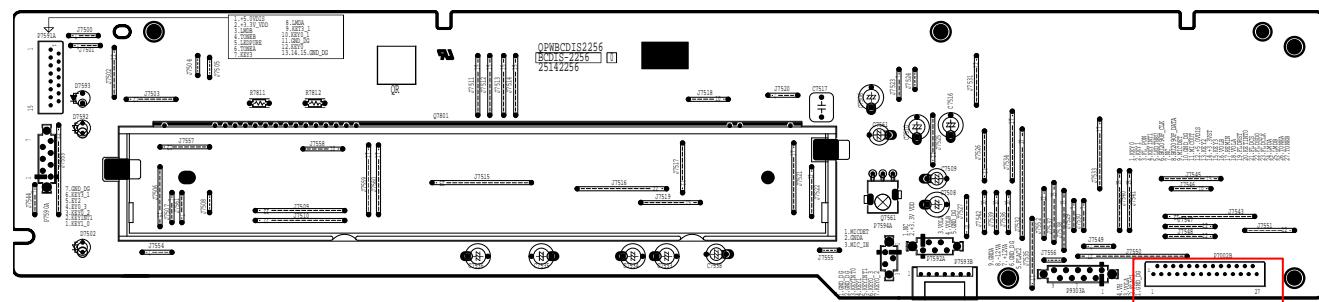

P7002B

BADIS-2256/1810(TX-)

● Each voltage is shown as the reference value.  
● 各電圧は実測した標準値です

# Block Diagram (Audio section)

# Schematic Diagram

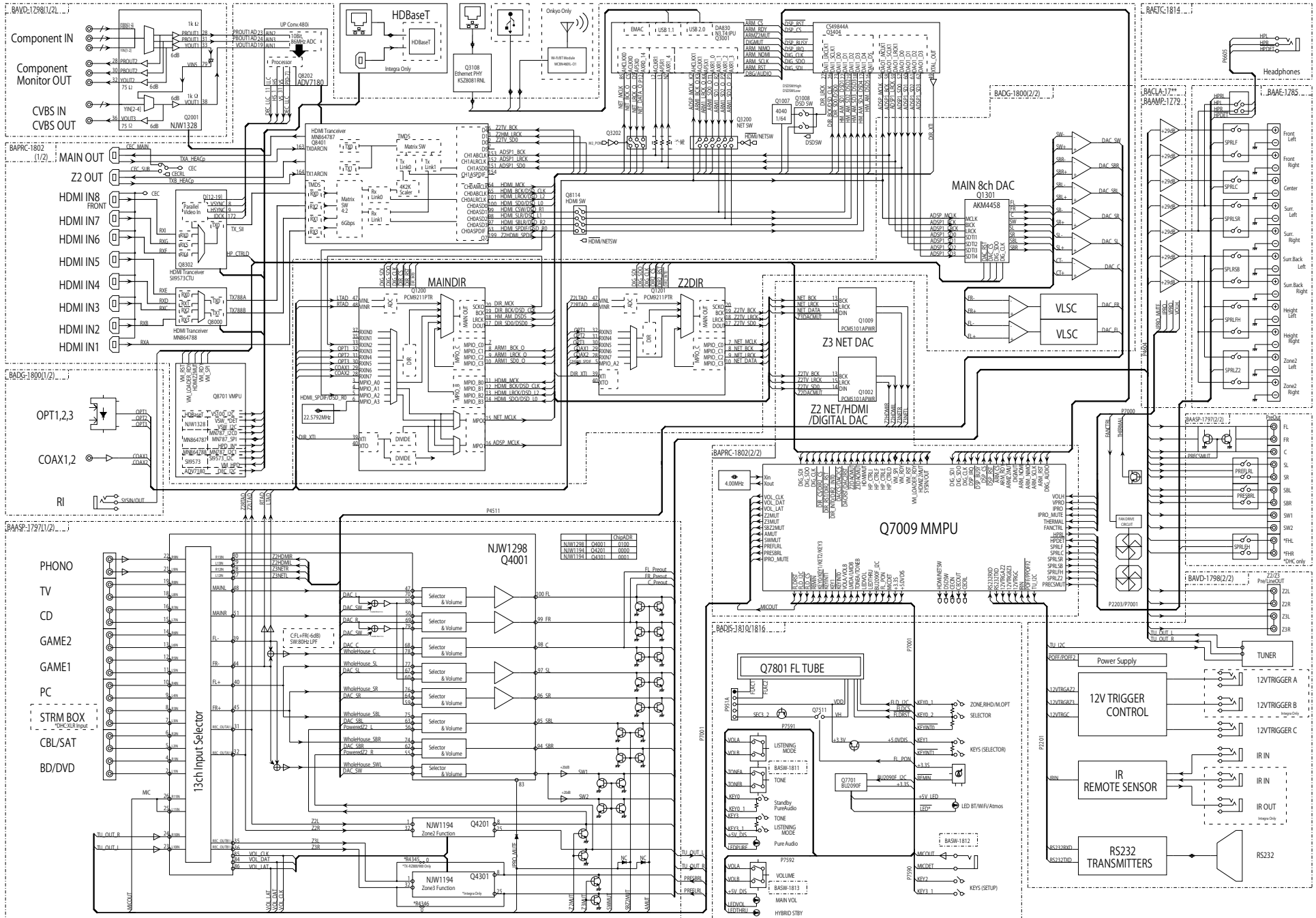

# Block Diagram (Power Section)

# Schematic Diagram

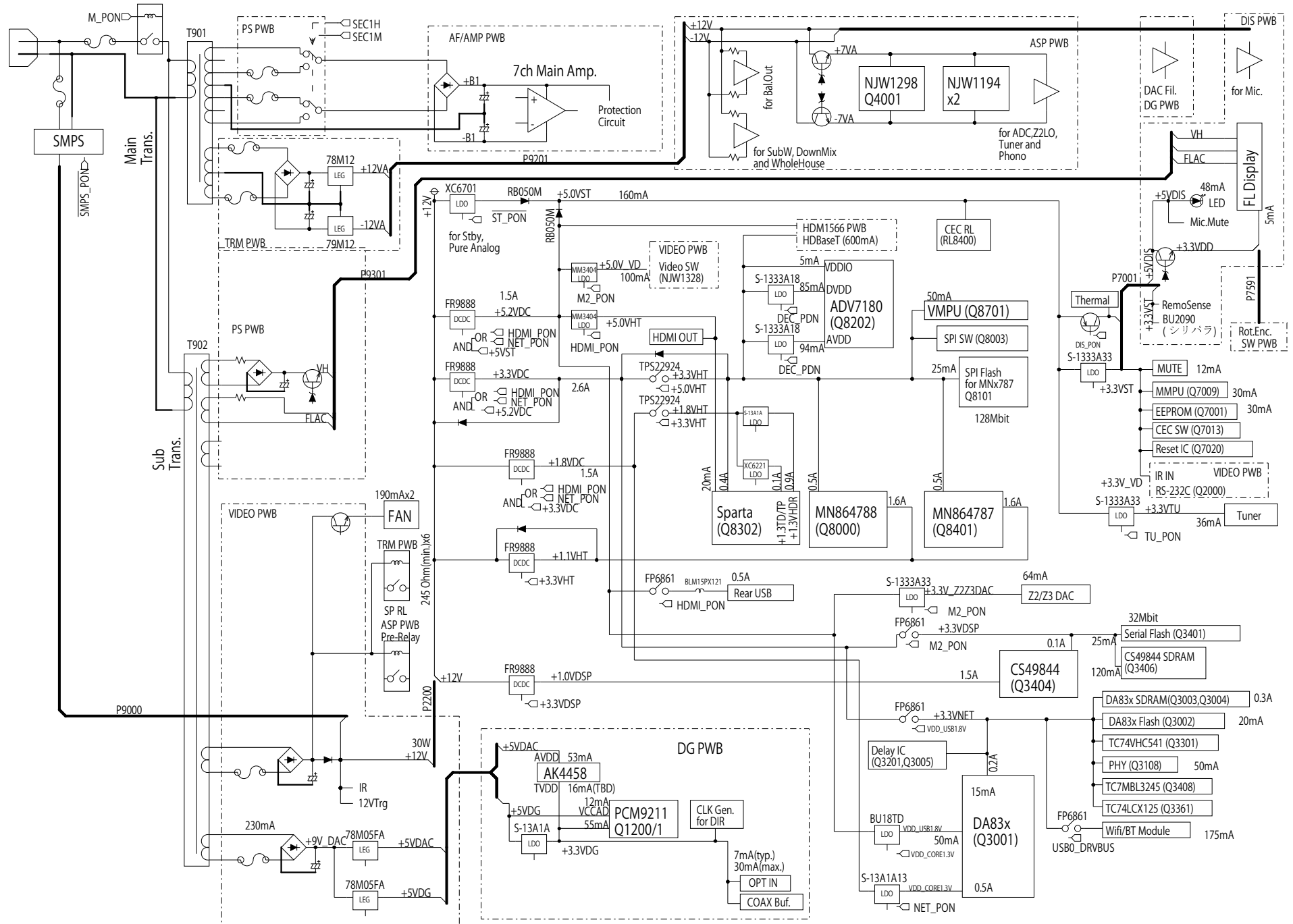

Model No. TX-RZ800/900,DTR-50.7/60.7

SCHEMATIC DIAGRAM (PART-5)

POWER AMP(Final Stage) SECTION

BAAMP-1779

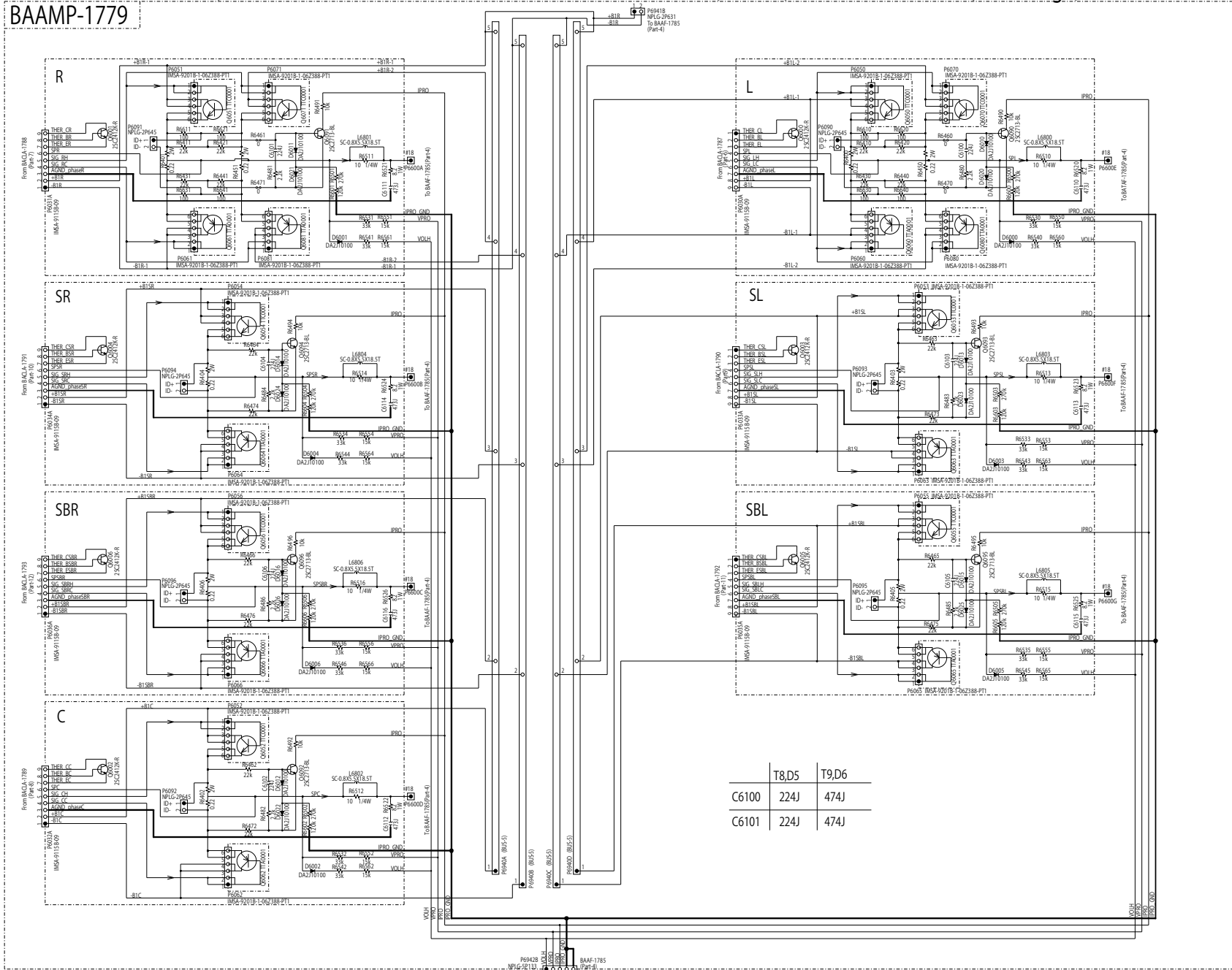

	T8,D5	T9,D6
C610	224J	474J
C6101	224J	474J



MODEL NO. TX-RZ800/900,DTR-50.7/60.7,DHC-60.7

SCHEMATIC DIAGRAM (PART-4) ASP SECTION

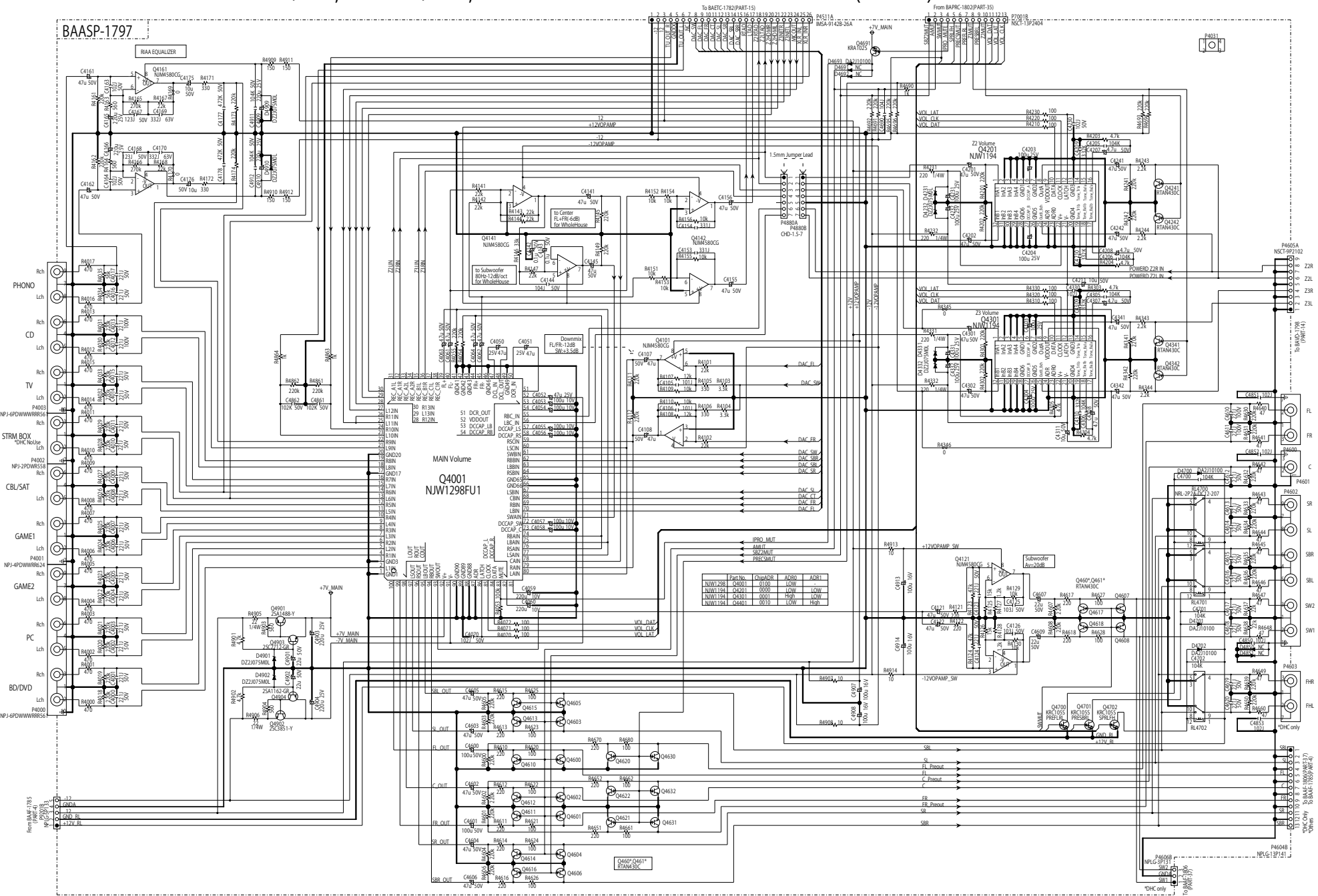





AMP(VoltageAMP) SECTION

Schematic Diagram

Model No. TX-NR800/900,DTR-50.7/60.7 SCHEMATIC DIAGRAM (PART-6)  
AMP(VoltageAMP) SECTION

BACLA-1787

BACLA-1787

All ch are same PCB. It can use anywhere.

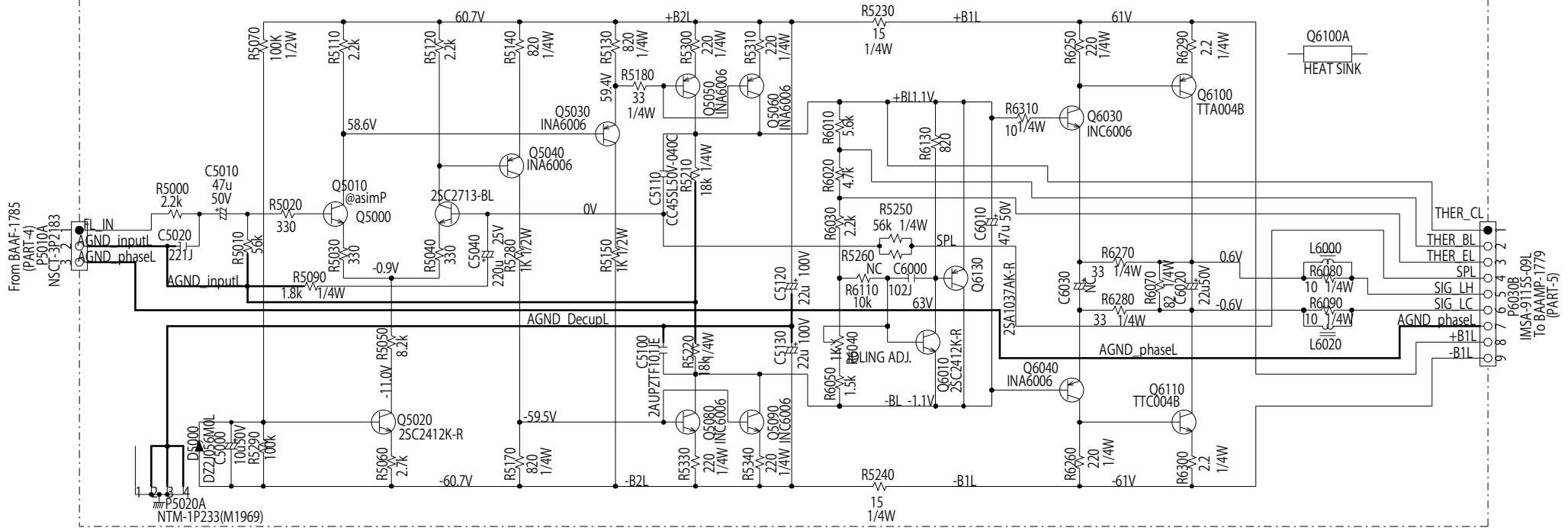

MSA-91155-091  
To BAAAF-1779  
(PART-5)

AMP(VoltageAMP) SECTION

Schematic Diagram

Model No. TX-RZ800/900,DTR-50.7/60.7 SCHEMATIC DIAGRAM (PART-7)

AMP(VoltageAMP) SECTION

BACLA-1788

R

BACLA-1788

All ch are same PCB.It can use anywhere.

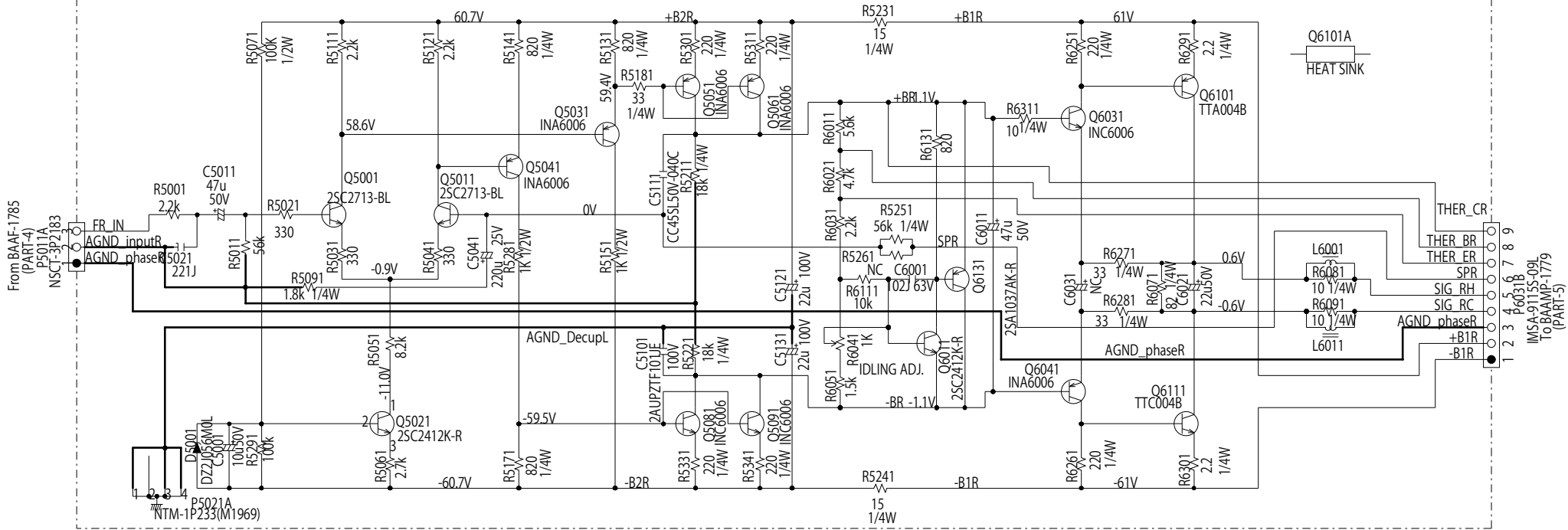

From BAAF-1785 (PART-4) P5011A NSCT-3P2183

AGND inputR AGND\_phaseR

NSCT-3P2183

NSCT-3P2183

NSCT-3P2183

NSCT-3P2183

NSCT-3P2183

NSCT-3P2183

NSCT-3P2183

NSCT-3P2183

NSCT-3P2183

NSCT-3P2183

NSCT-3P2183

NSCT-3P2183

NSCT-3P2183

NSCT-3P2183

NSCT-3P2183

NSCT-3P2183

NSCT-3P2183

NSCT-3P2183

NSCT-3P2183

NSCT-3P2183

NSCT-3P2183

NSCT-3P2183

NSCT-3P2183

NSCT-3P2183

NSCT-3P2183

NSCT-3P2183

NSCT-3P2183

NSCT-3P2183

NSCT-3P2183

NSCT-3P2183

NSCT-3P2183

NSCT-3P2183

NSCT-3P2183

NSCT-3P2183

NSCT-3P2183

NSCT-3P2183

NSCT-3P2183

NSCT-3P2183

NSCT-3P2183

NSCT-3P2183

NSCT-3P2183

NSCT-3P2183

NSCT-3P2183

NSCT-3P2183

NSCT-3P2183

NSCT-3P2183

NSCT-3P2183

NSCT-3P2183

NSCT-3P2183

NSCT-3P2183

NSCT-3P2183

NSCT-3P2183

NSCT-3P2183

NSCT-3P2183

NSCT-3P2183

NSCT-3P2183

NSCT-3P2183

NSCT-3P2183

NSCT-3P2183

NSCT-3P2183

NSCT-3P2183

NSCT-3P2183

NSCT-3P2183

NSCT-3P2183

NSCT-3P2183

NSCT-3P2183

NSCT-3P2183

NSCT-3P2183

NSCT-3P2183

NSCT-3P2183

NSCT-3P2183

NSCT-3P2183

NSCT-3P2183

NSCT-3P2183

NSCT-3P2183

NSCT-3P2183

NSCT-3P2183

NSCT-3P2183

AMP(VoltageAMP) SECTION

Schematic Diagram

Model No. TX-RZ800/900,DTR-50.7/60.7 SCHEMATIC DIAGRAM (PART-8)

AMP(VoltageAMP) SECTION

BACLA-1789

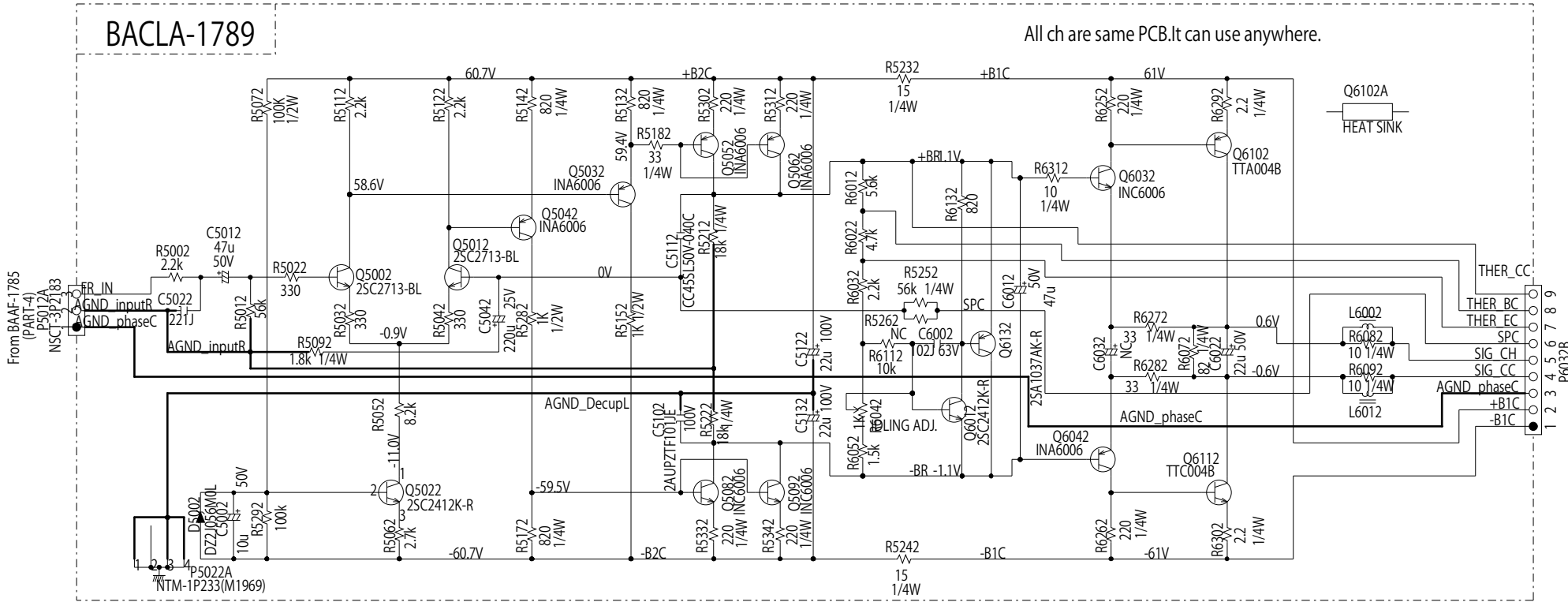

C

BACLA-1789

All ch are same PCB.It can use anywhere.

To BAAMP-1779  
(PART-5)

AMP(VoltageAMP) SECTION

Schematic Diagram

Model No. TX-RZ800/900,DTR-50.7/60.7 SCHEMATIC DIAGRAM (PART-9)

AMP(VoltageAMP) SECTION

BACLA-1790

SL

BACLA-1790

All ch are same PCB.It can use anywhere.

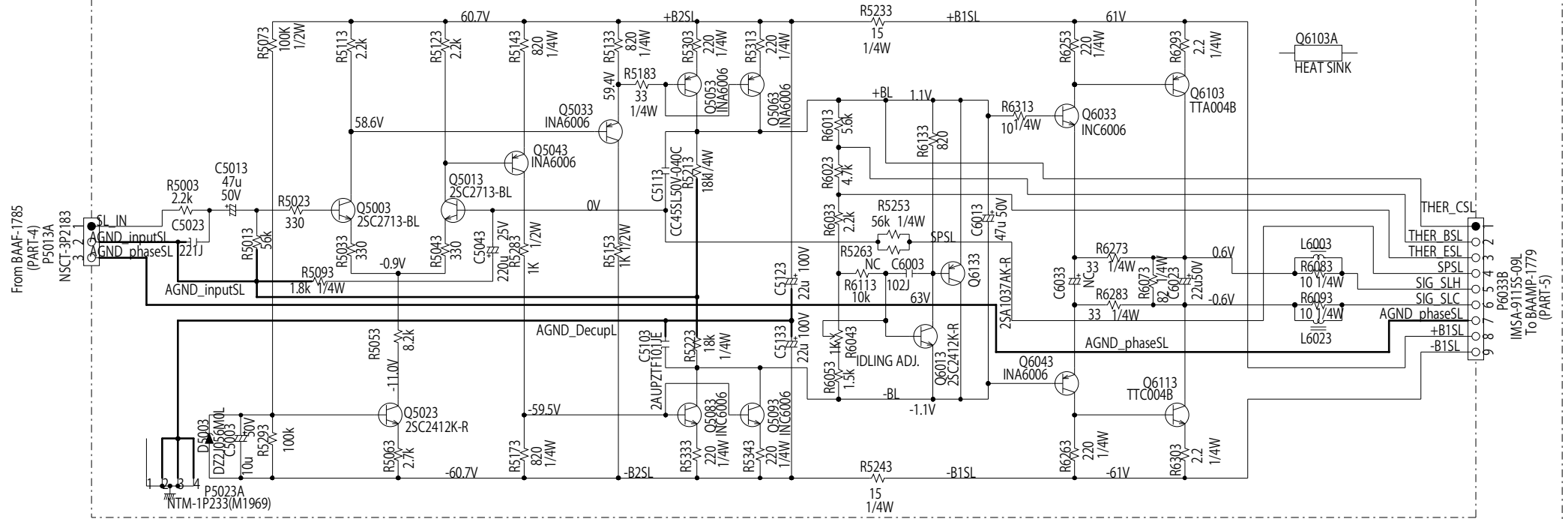

IMS-A-91155-09L  
To BAAAMP-1779  
(PART-5)







Model No. TX-RZ800/900,DTR-50.7/60.7 SCHEMATIC DIAGRAM (PART-12)

AMP(VoltageAMP) SECTION

BACLA-1793

SBR

BACLA-1793

All ch are same PCB.It can use anywhere.

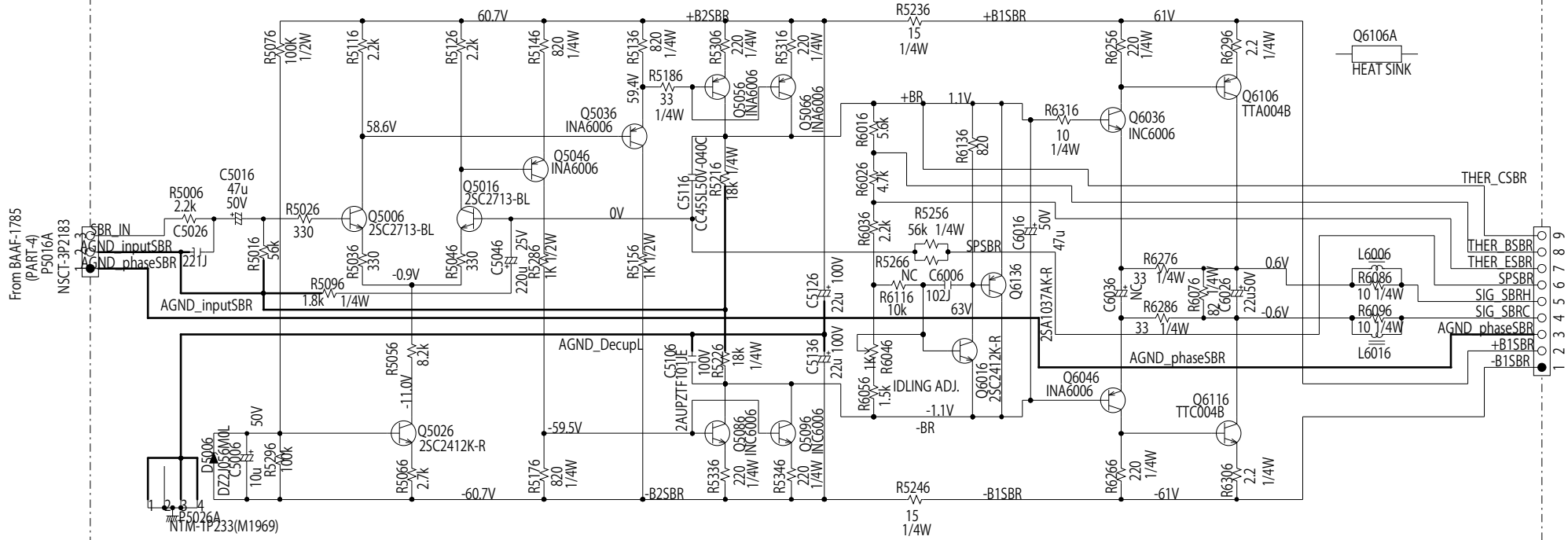

IMS-91155-09L  
To BAAMP-1779  
(PART-5)

# Main 8ch DAC

# Schematic Diagram

MODEL No. TX-RZ-800,900 DTR-50.7,60.7 DHC-60.7 SCHEMATIC DIAGRAM (PART-13)

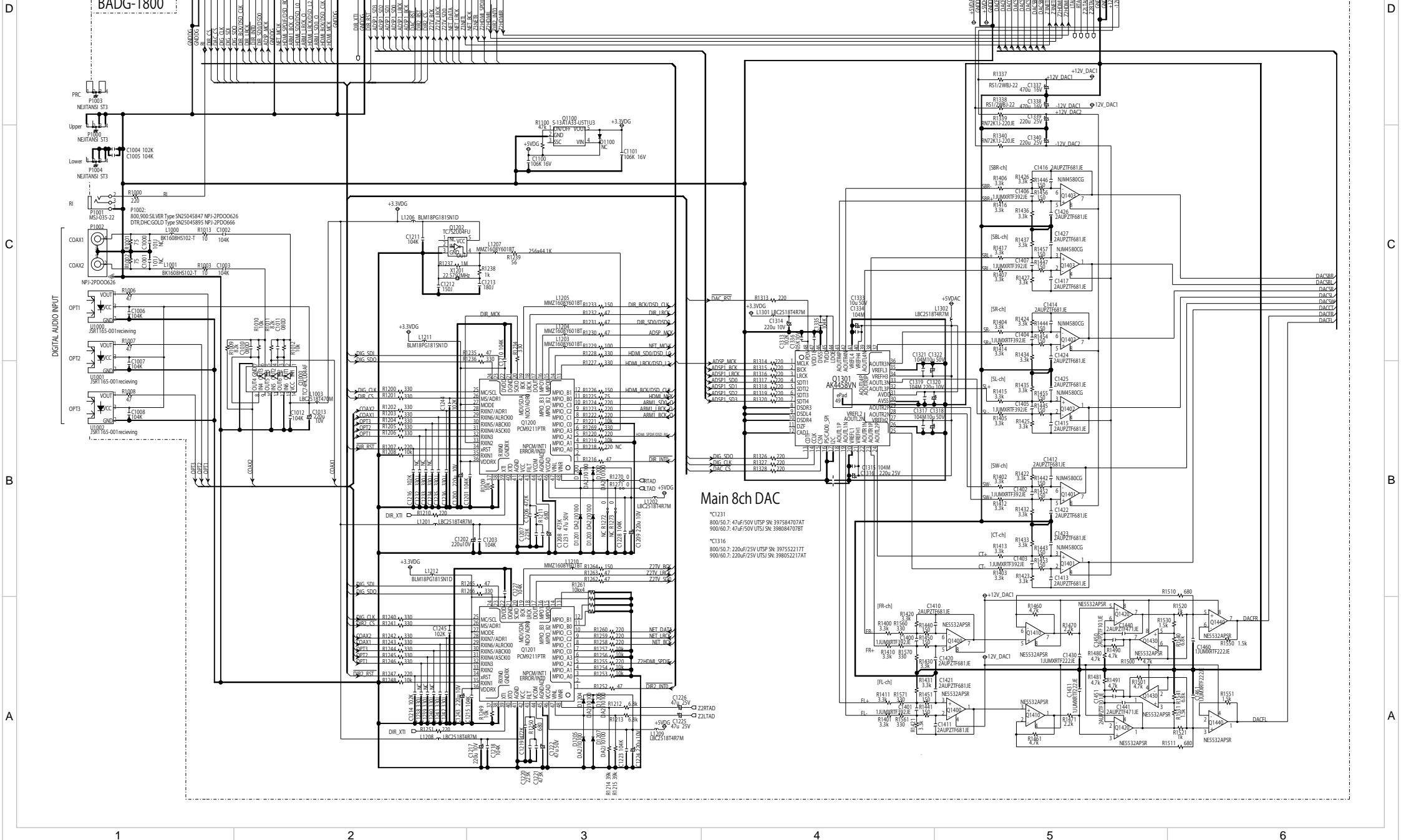

MODEL No.TX-RZ800/900,DTR-50.7/60.7,DHC-60.7 SCHEMATIC DIAGRAM (PART-14)  
ANALOG VIDEO SECTION

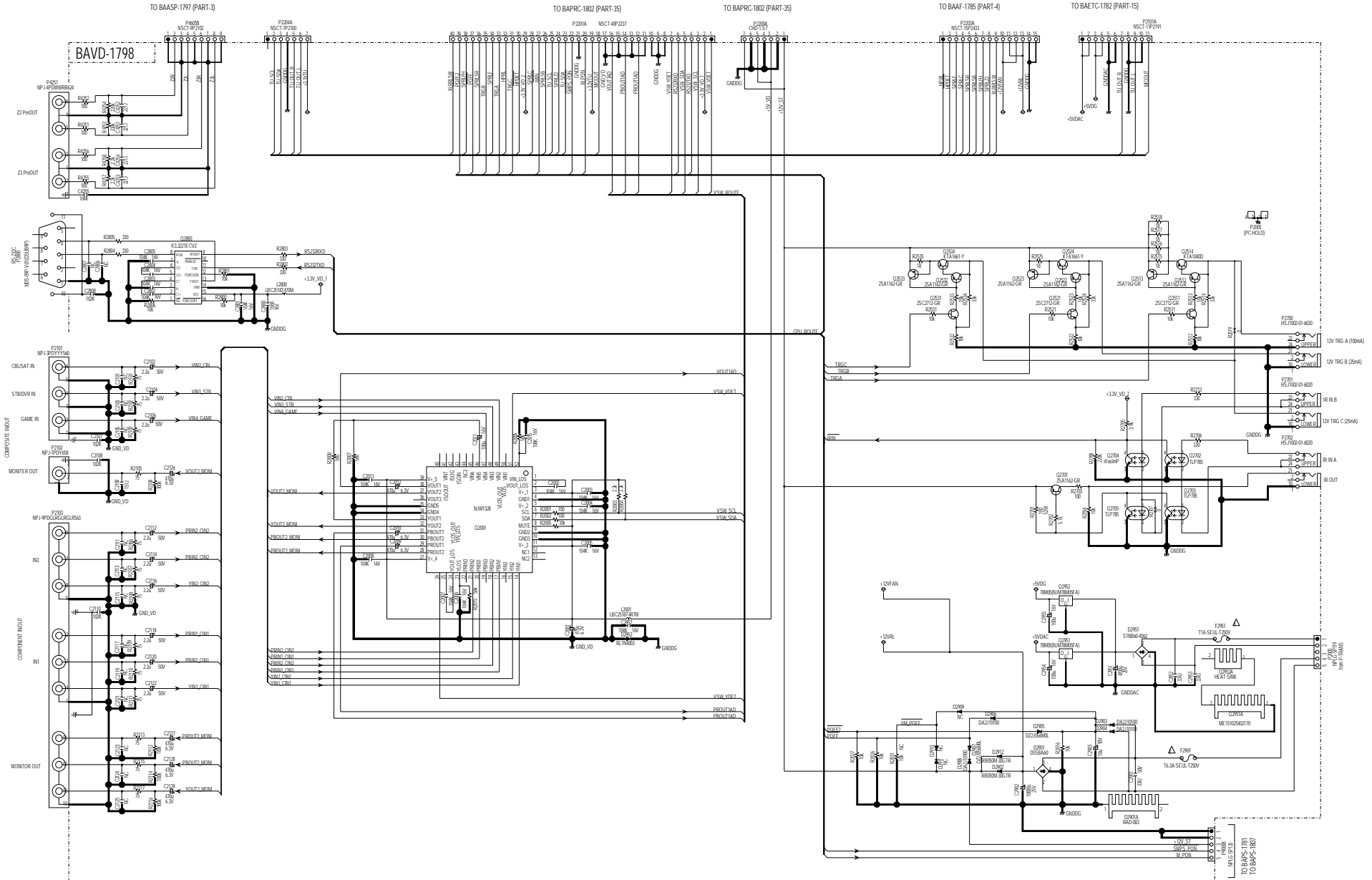



Model No. TX-RZ800, TX-RZ900, DTR-50.7, DTR-60.7 SCHEMATIC DIAGRAM (PART-16)  
AMP(Thermal sensor) SECTION

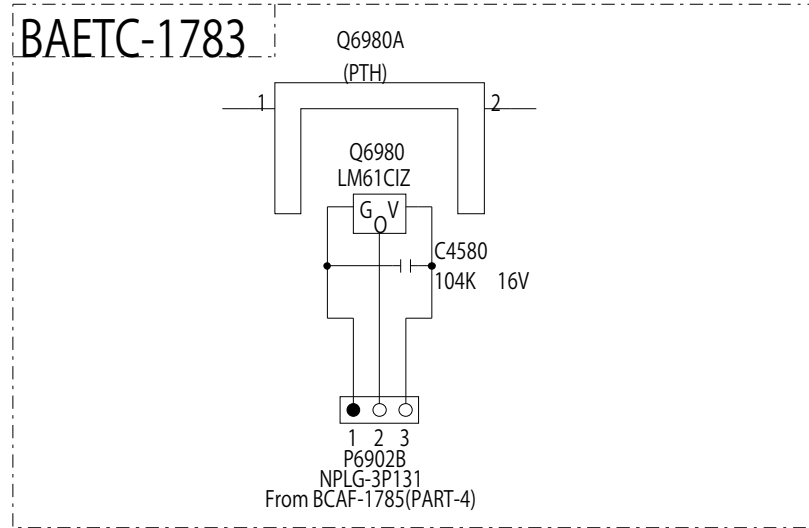

MODEL NO.TX-RZ800/900, DTR-50.7/60.7 SCHEMATIC DIAGRAM(PART-17)

TO BADG-1800 (PART-13)

P1008A

IMSA-9142S-24A

BAETC-1795

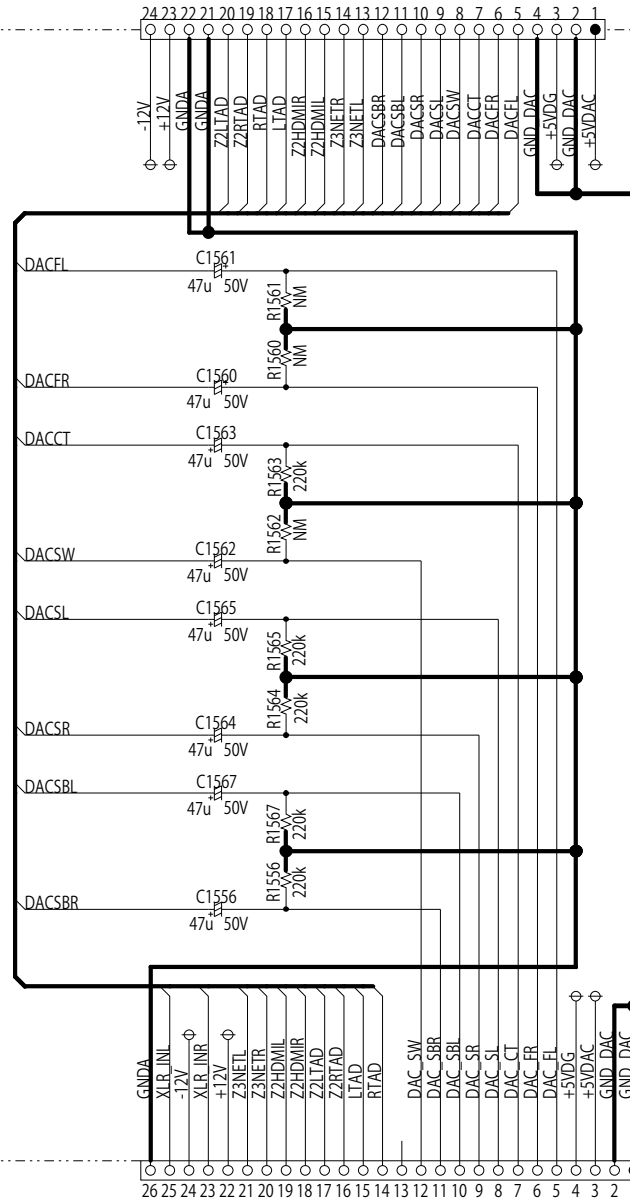

IMSA-9142S-26A

P4591B

TO BAETC-1782 (PART-15)





# MODEL NO. TX-RZ800/900 SCHEMATIC DIAGRAM(PART-19) DISPLAY(KEY)SECTION

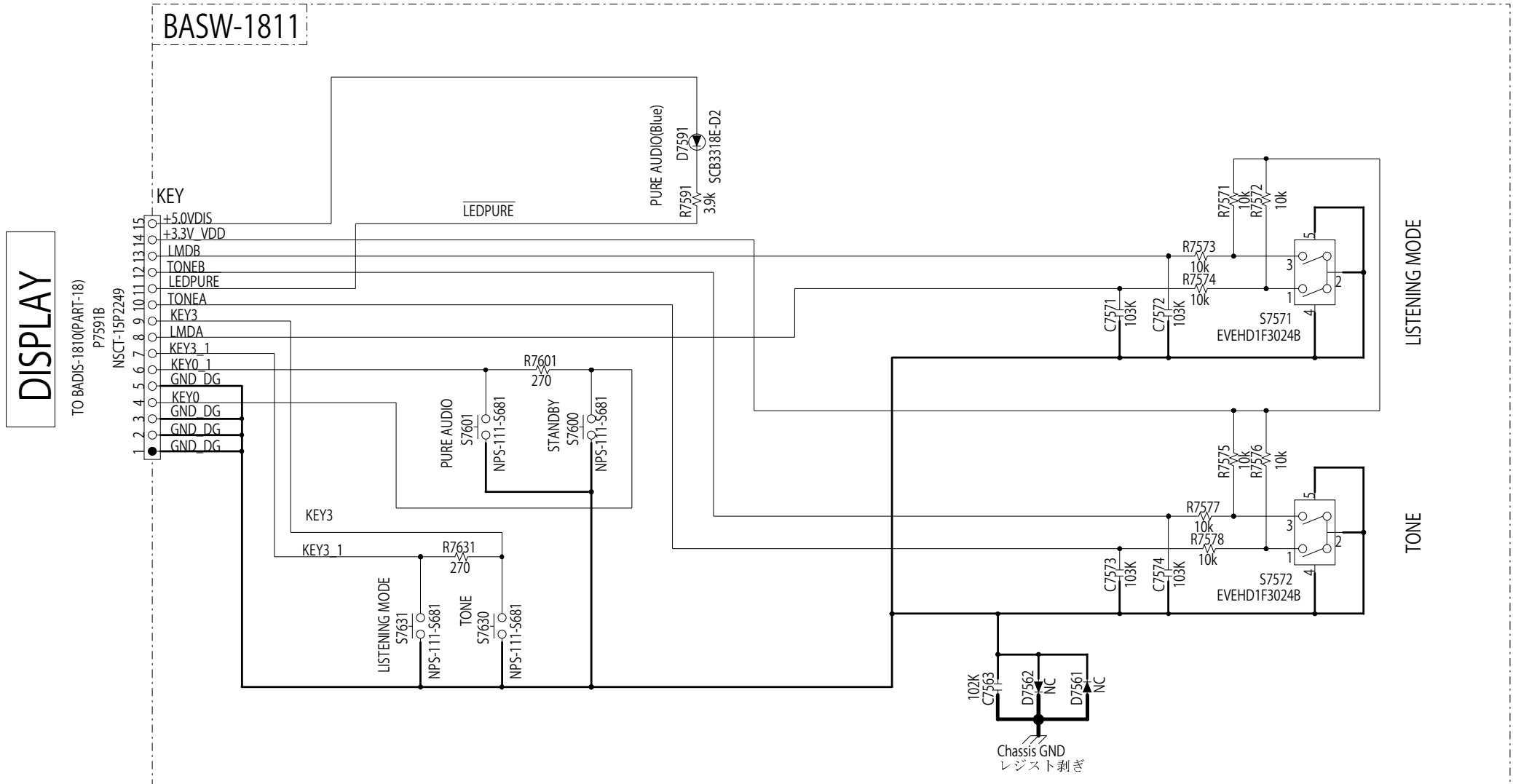

# MODEL NO.TX-RZ800/900 SCHEMATIC DIAGRAM(PART-20) DISPLAY(MIC)SECTION

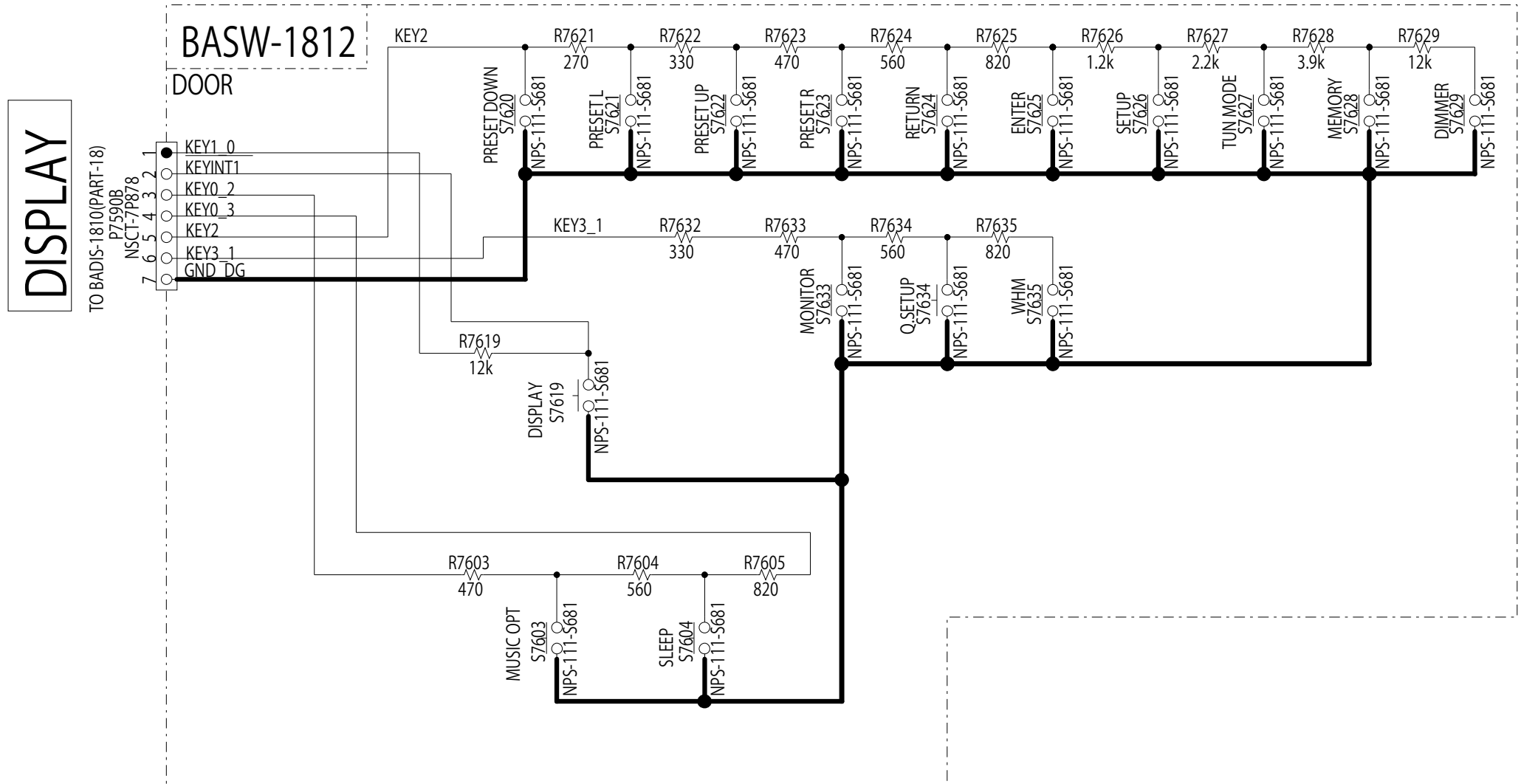



# MODEL NO.TX-RZ800/900 SCHEMATIC DIAGRAM(PART-22) DISPLAY(MIC)SECTION

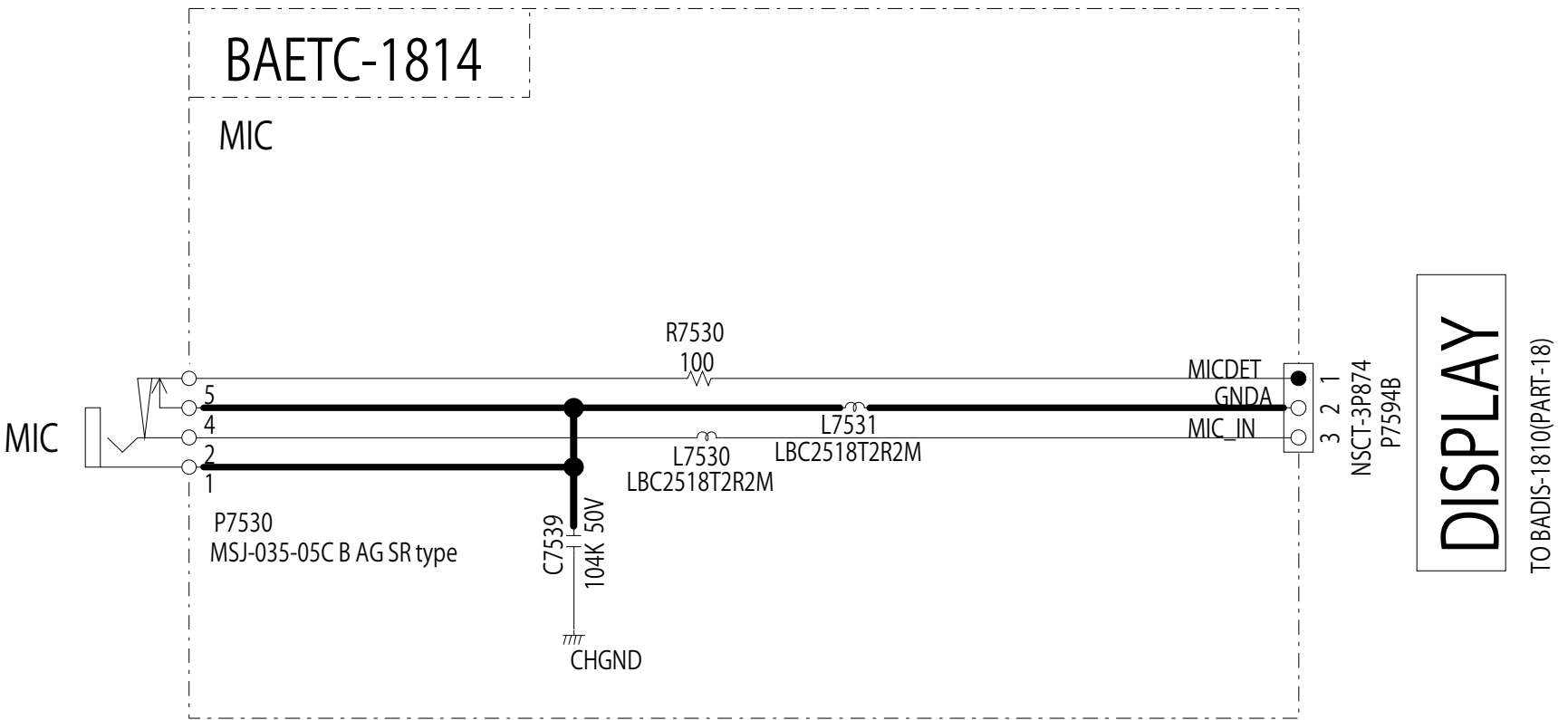

# MODEL NO.TX-RZ800/900 SCHEMATIC DIAGRAM(PART-24) DISPLAY(HEADPHONE)SECTION

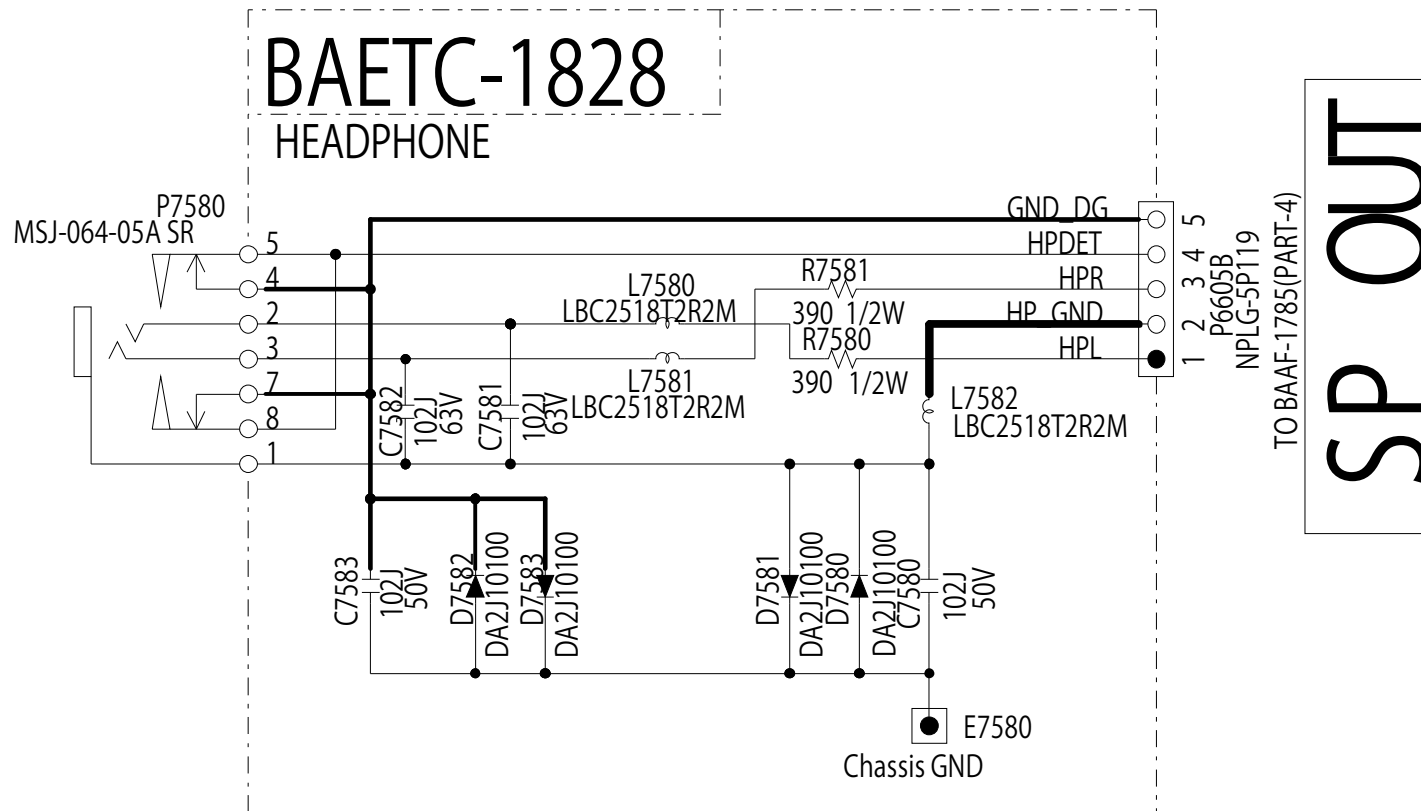

TUNER SECTION

Schematic Diagram

MODEL NO. TX-SR343/444,HT-R394/494/594

SCHEMATIC DIAGRAM (PART-10) TUNER SECTION

MODEL NO. TX-NR545/646/RZ700,DTR-20.7/30.7/40.7

SCHEMATIC DIAGRAM (PART-25) TUNER SECTION

MODEL NO. TX-RZ800/900

SCHEMATIC DIAGRAM (PART-25) TUNER SECTION

BARF-1738:TX-SR343/444,HT-R394/494/594  
 BARF-1731:TX-NR545/646, TX-RZ700  
 BARF-1730:DTR-20.7/30.7/40.7  
 BARF-1829:TX-RZ800/900

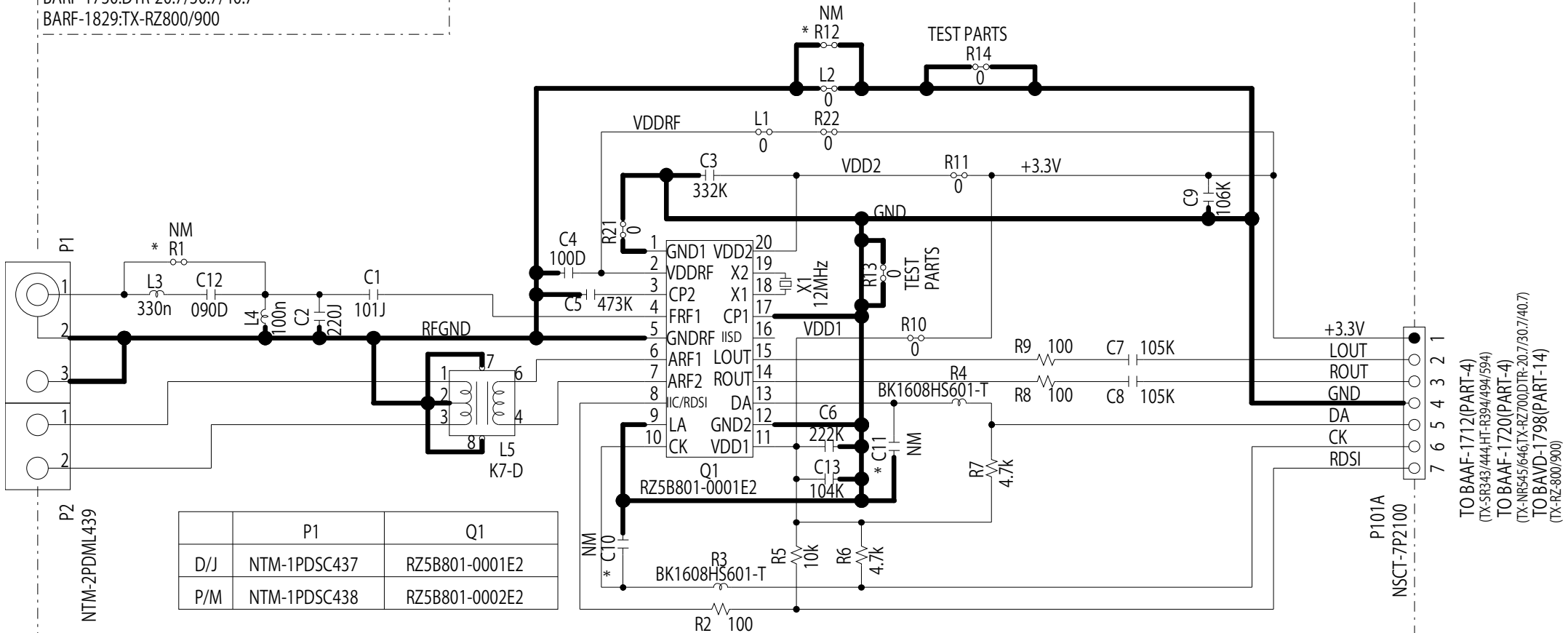

	P1	Q1
D/J	NTM-1PDSC437	RZ5B801-0001E2
P/M	NTM-1PDSC438	RZ5B801-0002E2

TO BAAF-1712(PART-4)  
 (TX-SR343/444,HT-R394/494/594)  
 TO BAAF-1720(PART-4)  
 (TX-NR545/646, TX-RZ700,DTR-20.7/30.7/40.7)  
 TO BAVD-1798(PART-14)  
 (TX-RZ-800/900)



MODEL NO. DTR-50.7/60.7 DHC-60.7 SCHEMATIC DIAGRAM(PART-27)DISPLAY(KEY)SECTION

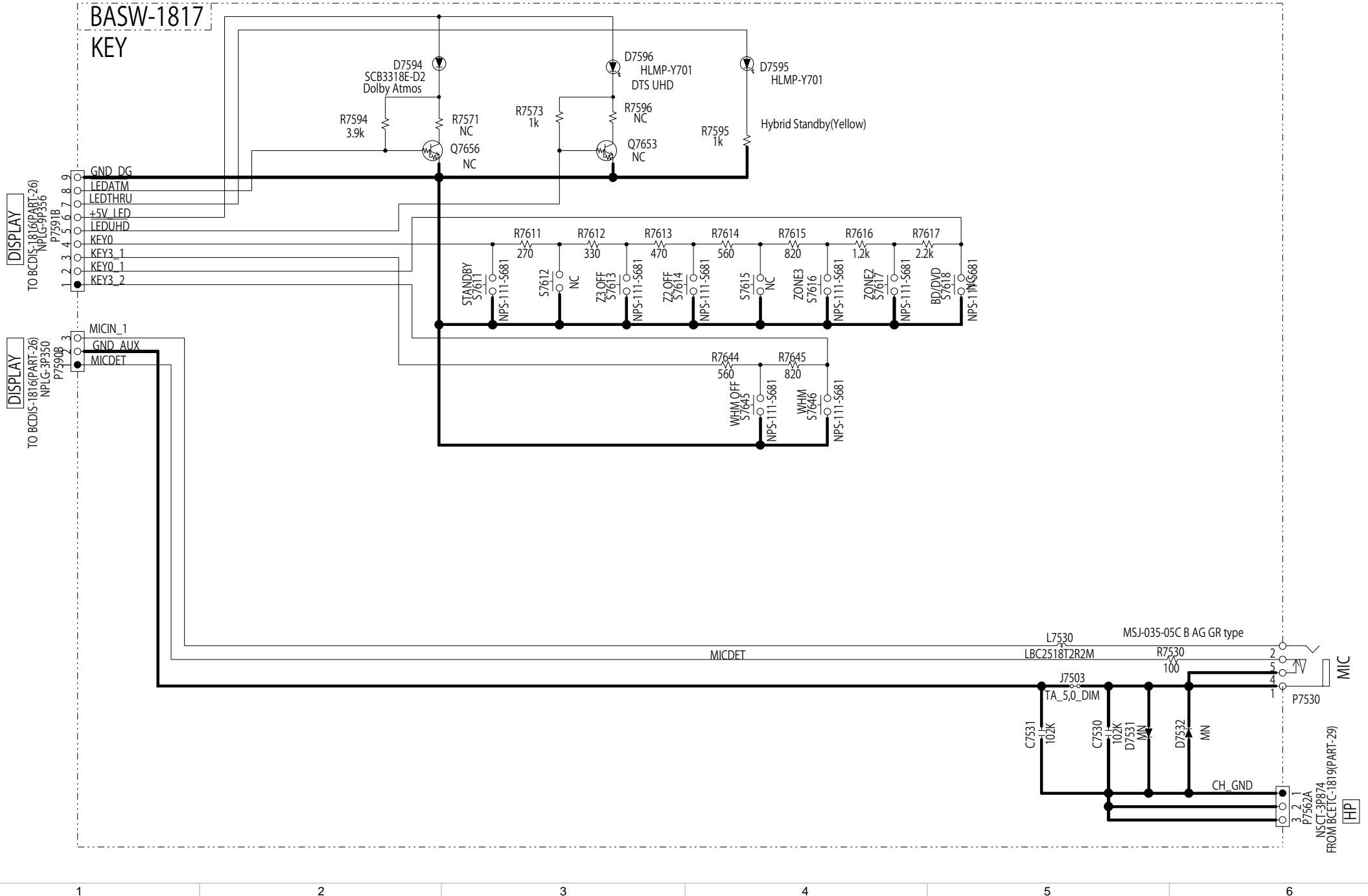



MODEL NO.DTR-50.7/60.7 DHC-60.7 SCHEMATIC DIAGRAM  
DISPLAY(VOLUME)SECTION (PART-28)

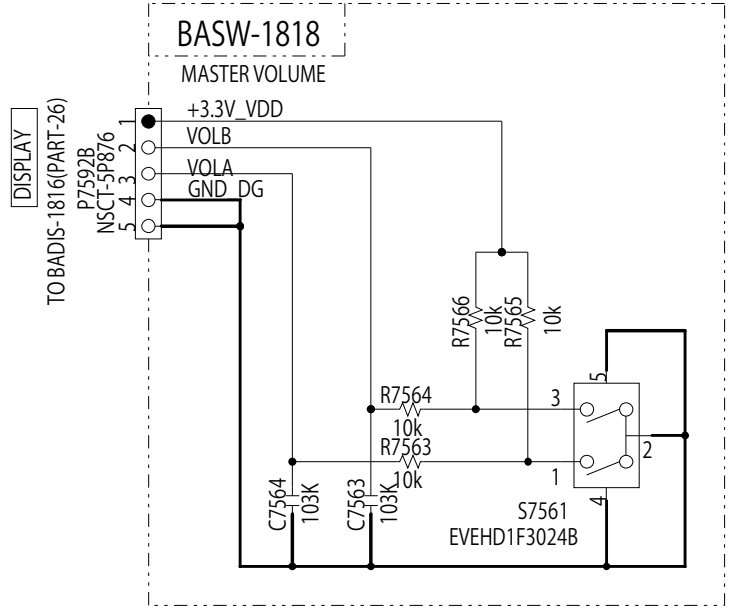



MODEL NO. DTR-50.7/60.7,DHC-60.7

SCHEMATIC DIAGRAM (PART-30) TUNER SECTION

BARF-1821

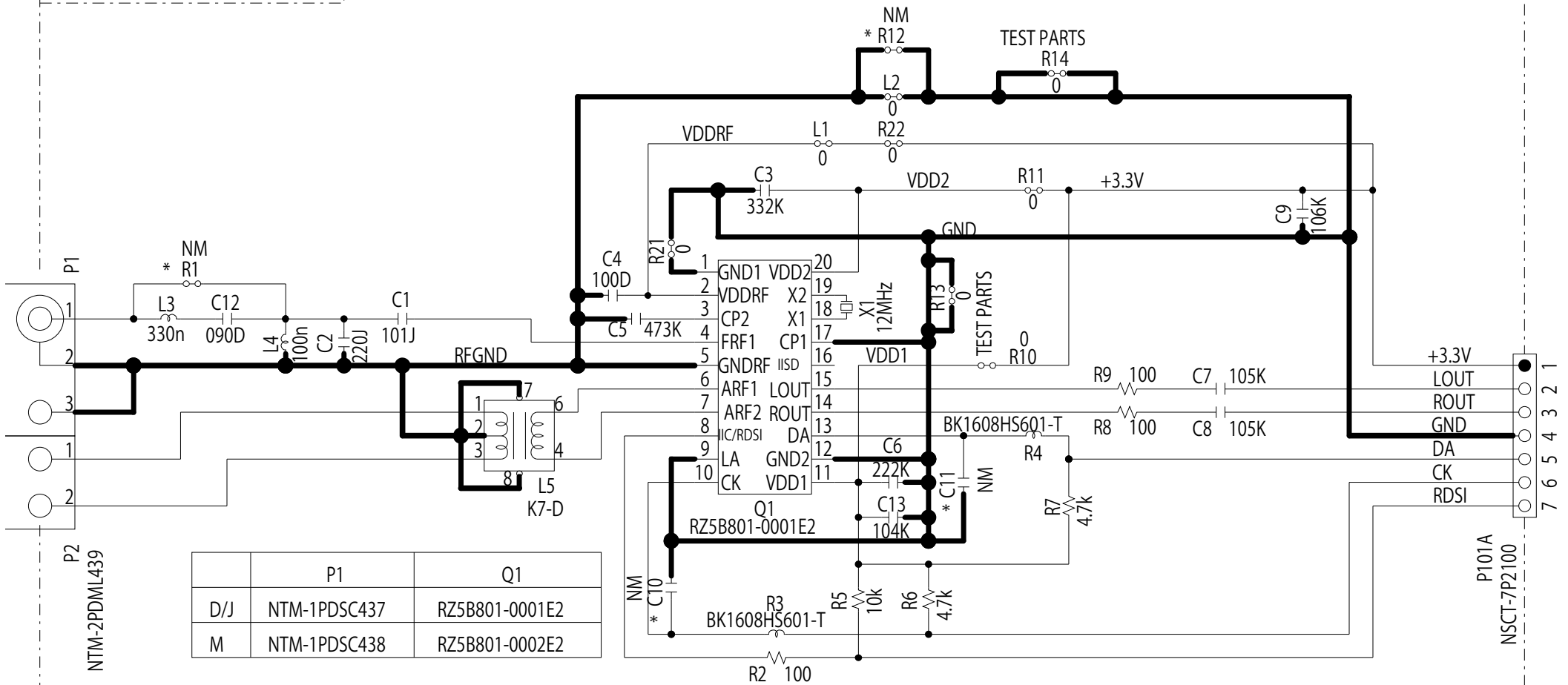

TO BAVD-1798(PART-14)

DISPLAY(Power supply) SECTION

Schematic Diagram

Model No. TX-RZ800/900,DTR-50.7/60.7 SCHEMATIC DIAGRAM (PART-31)  
DISPLAY(Power supply) SECTION

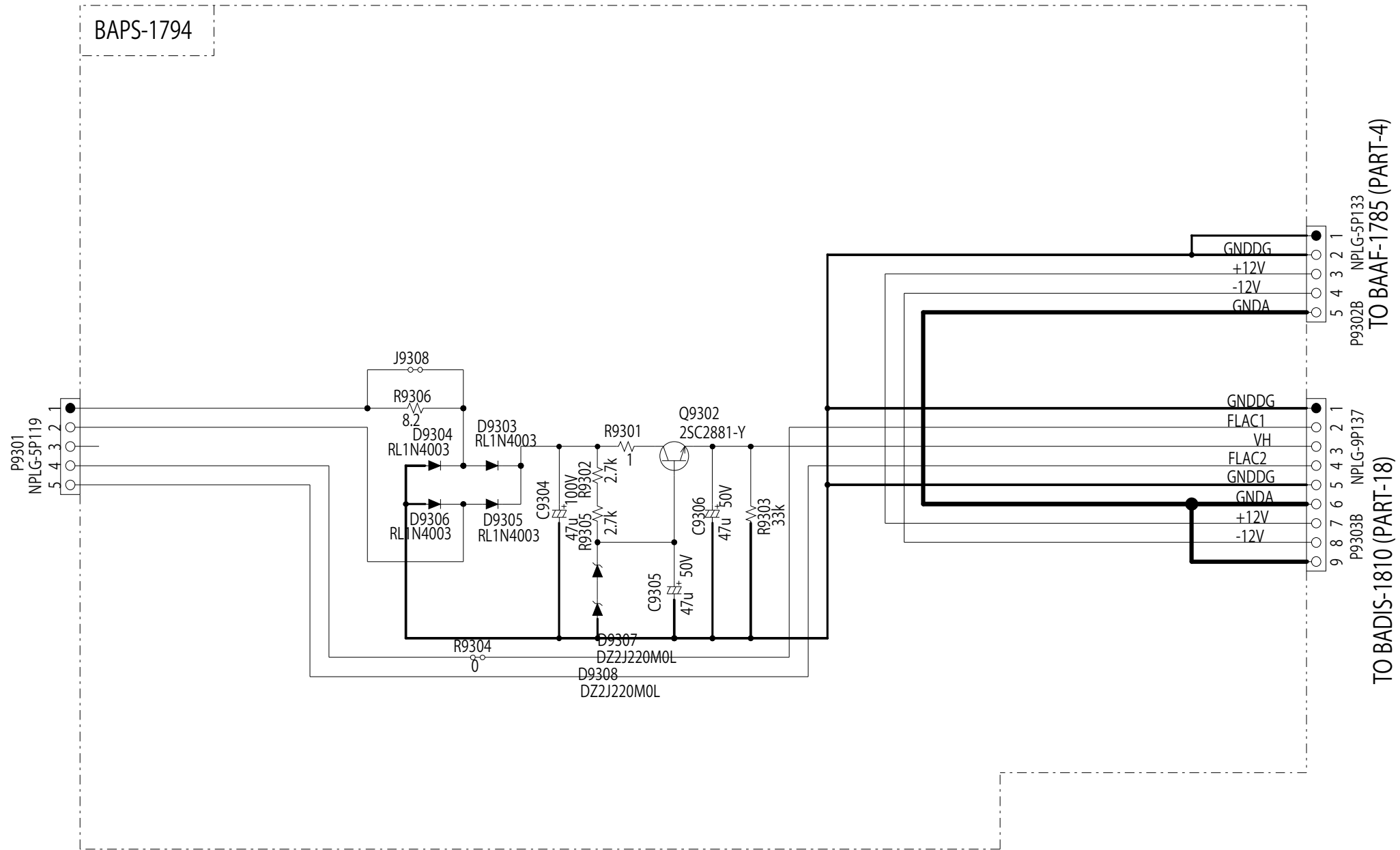

# AMP(Power supply) SECTION

# Schematic Diagram

Model No. TX-RZ800/900,DTR-50.7/60.7 SCHEMATIC DIAGRAM (PART-32)  
AMP(Power supply) SECTION

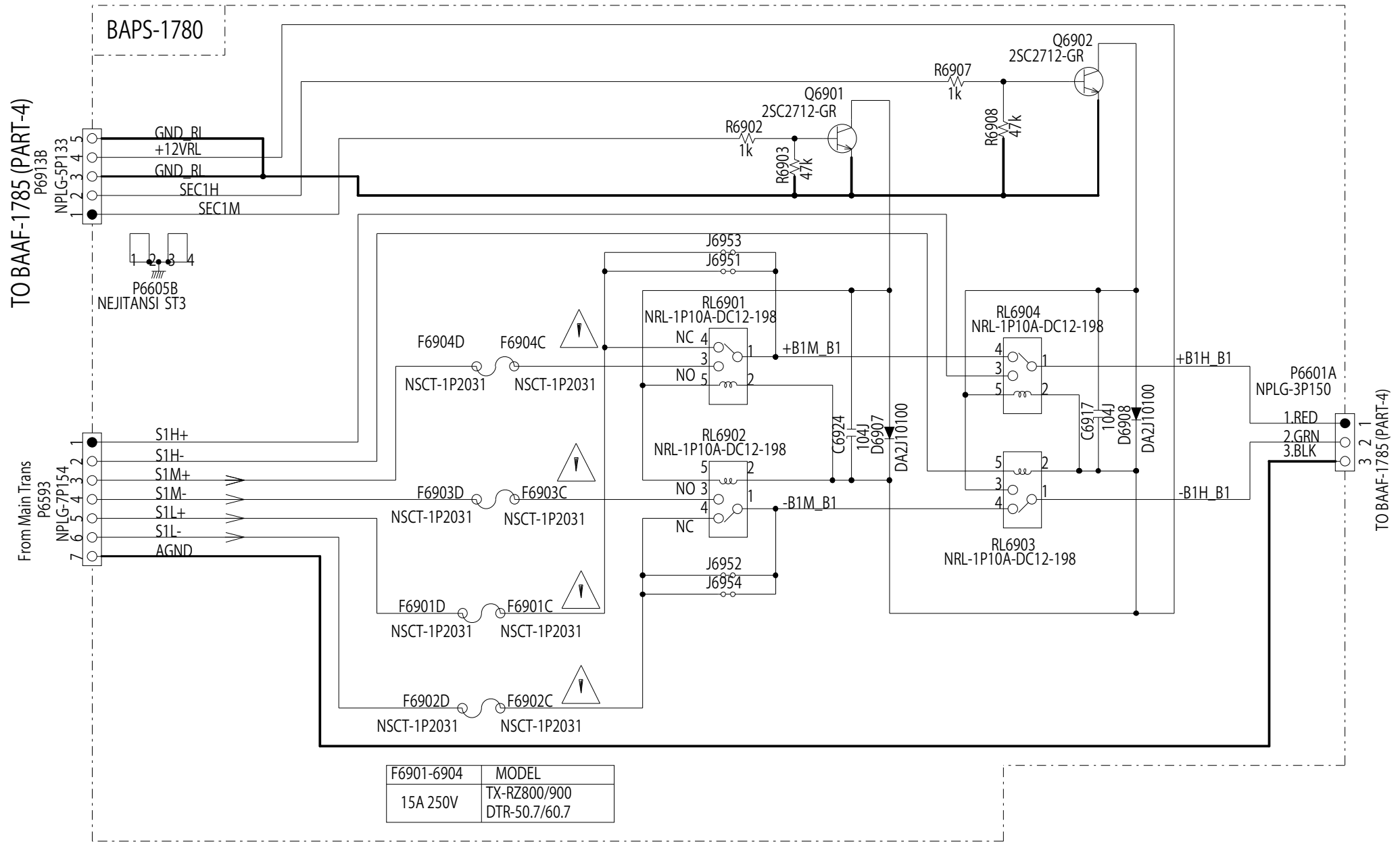

MODEL NO. TX-RZ800/900,DTR-50.7/60.7 SCHEMATIC DIAGRAM (PART-33) PS SECTION

THE COMPONENTS IDENTIFIED MARK  $\Delta$  ARE CRITICAL FOR SAFETY. REPLACE ONLY WITH PART NUMBER SPECIFIED.  
 VOLTAGE (MEASURED WITH VOLTMETER) IS DC VOLTAGE. (NO INPUT SIGNAL).  
 ELECTROLYTIC CAPACITORS (E) ARE IN  $\mu$ F/W.  
 ALL CAPACITORS ARE IN  $\mu$ F/50W UNLESS OTHERWISE NOTED.  
 EX) 100  $\rightarrow$  3 $\mu$ F, 330  $\rightarrow$  33 $\mu$ F, 331  $\rightarrow$  330 $\mu$ F, 333  $\rightarrow$  0.033 $\mu$ F  
 CIRCUIT IS SUBJECT TO CHANGE FOR IMPROVEMENT.

$\Delta$ 印は火災、感電の危険に関与する部品の為、必ず指定部品を使用の事。  
 電圧表示は無信号時に測定した直流電圧を示す。  
 記入なき電解コンデンサの単位は $\mu$ F/W である。  
 記入なきコンデンサの単位は $\mu$ F である。  
 例) 100  $\rightarrow$  3 $\mu$ F, 330  $\rightarrow$  33 $\mu$ F, 331  $\rightarrow$  330 $\mu$ F, 333  $\rightarrow$  0.033 $\mu$ F  
 本配線図は基本配線図につき性能改善等により予告なく変更する事がある。

CAUTION  
 FOR CONTINUED PROTECTION AGAINST FIRE HAZARD,  
 REPLACE ONLY WITH FUSE OF SAME TYPE AND RATING INDICATED.

ATTENTION  
 AFIN D'ASSURER UNE PROTECTION PERMANENTE CONTRE LES RISQUES D'INCENDIE,  
 REMPLACER UNIQUEMENT PAR UN FUSIBLE DE MEME TYPE ET CALIBRATION COMME INDIQUE.

THIS SYMBOL LOCATED NEAR THE FUSE INDICATES THAT THE FUSE USED IS SLOW OPERATING TYPE  
 FOR CONTINUED PROTECTION AGAINST FIRE HAZARD, REPLACE WITH SAME TYPE FUSE.  
 RATING REFER TO THE MAKING ADJACENT TO THE SYMBOL.

CE SYMBOLE INDIQUE QUE LE FUSIBLE UTILISE EST A LENT, E POUR UNE PROTECTION PERMANENT.  
 UTILISER DES FUSIBLES DE MEME TYPE.  
 CE DERNIER EST INDIQUE LA QU'LE PRESENT SYMBOLE EST APOSE.

Main/Sub Trans Table

Model	Voltage	T901	P902
T8/D5	100V	NPT-16531	-
	120V	NPT-1653D	-
	220-240V	NPT-1653M	-
T9/D6	120V	NPT-1654D	NPT-1655D
	220-240V	NPT-1654M	NPT-1655M

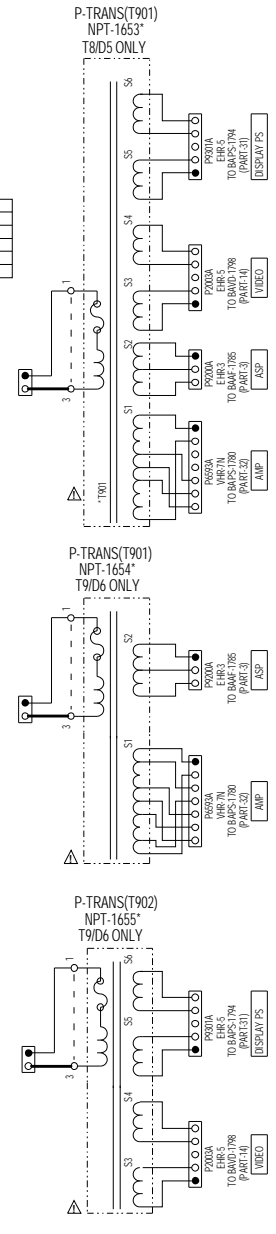
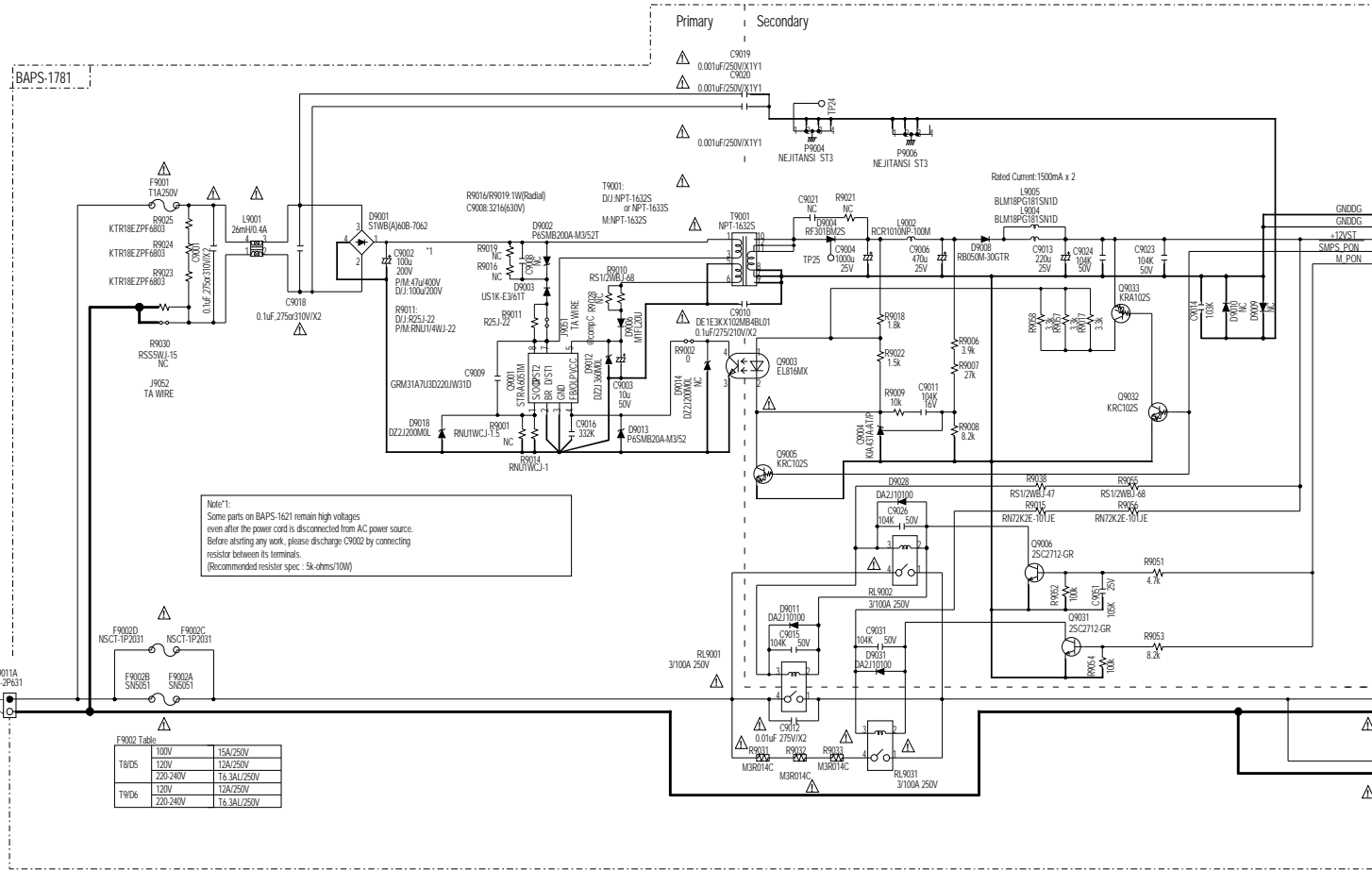

F9002 Table

	100V	15A/250V
T8/D5	120V	12A/250V
	220-240V	T6.3A/250V
T9/D6	120V	12A/250V
	220-240V	T6.3A/250V

MODEL NO. DHC-60.7 SCHEMATIC DIAGRAM (PART-34) PS SECTION

THE COMPONENTS IDENTIFIED MARK  $\Delta$  ARE CRITICAL FOR SAFETY. REPLACE ONLY WITH PART NUMBER SPECIFIED.  
 VOLTAGE (MEASURED WITH VOLTMETER IS DC VOLTAGE. (NO INPUT SIGNAL)  
 ELECTROLYTIC CAPACITORS (  $\text{---}||\text{---}$  ) ARE IN  $\mu\text{F}/\text{VW}$ .  
 ALL CAPACITORS ARE IN  $\mu\text{F}/50\text{V}$  UNLESS OTHERWISE NOTED.  
 EX) 100  $\rightarrow$  3 $\mu\text{F}$ , 330  $\rightarrow$  33 $\mu\text{F}$ , 331  $\rightarrow$  330 $\mu\text{F}$ , 333  $\rightarrow$  0.033 $\mu\text{F}$   
 CIRCUIT IS SUBJECT TO CHANGE FOR IMPROVEMENT.

$\Delta$ 印は火災、感電の危険に関与する部品の為、必ず指定部品を使用の事。  
 電圧表示は無信号時に測定した直流電圧を示す。  
 記入なき電解コンデンサの単位は $\mu\text{F}/\text{VW}$ である。  
 記入なきコンデンサの単位は $\mu\text{F}$ である。  
 例) 100  $\rightarrow$  3 $\mu\text{F}$ , 330  $\rightarrow$  33 $\mu\text{F}$ , 331  $\rightarrow$  330 $\mu\text{F}$ , 333  $\rightarrow$  0.033 $\mu\text{F}$   
 本配線図は基本配線図につき性能改善等により予告なく変更する事がある。

CAUTION  
 FOR CONTINUED PROTECTION AGAINST FIRE HAZARD,  
 REPLACE ONLY WITH FUSE OF SAME TYPE AND RATING INDICATED.

ATTENTION  
 AFIN D'ASSURER UNE PROTECTION PERMANENTE CONTRE LES RISQUES D'INCENDIE,  
 REMPLACER UNIQUEMENT PAR UN FUSIBLE DE MEME TYPE ET CALIBRATION COMME INDIQUE.

THIS SYMBOL LOCATED NEAR THE FUSE INDICATES THAT THE FUSE USED IS SLOW OPERATING TYPE  
 FOR CONTINUED PROTECTION AGAINST FIRE HAZARD, REPLACE WITH SAME TYPE FUSE.  
 RATING REFER TO THE MAKING ADJACENT TO THE SYMBOL.

CE SYMBOLE INDIQUE QUE LE FUSIBLE UTILISE EST A LENT, E POUR UNE PROTECTION PERMANENT.  
 UTILISER QUE DES FUSIBLES DE MEME TYPE.  
 CE DERNIER EST INDIQUE LA COULE PRESENT SYMBOLE EST APOSE.

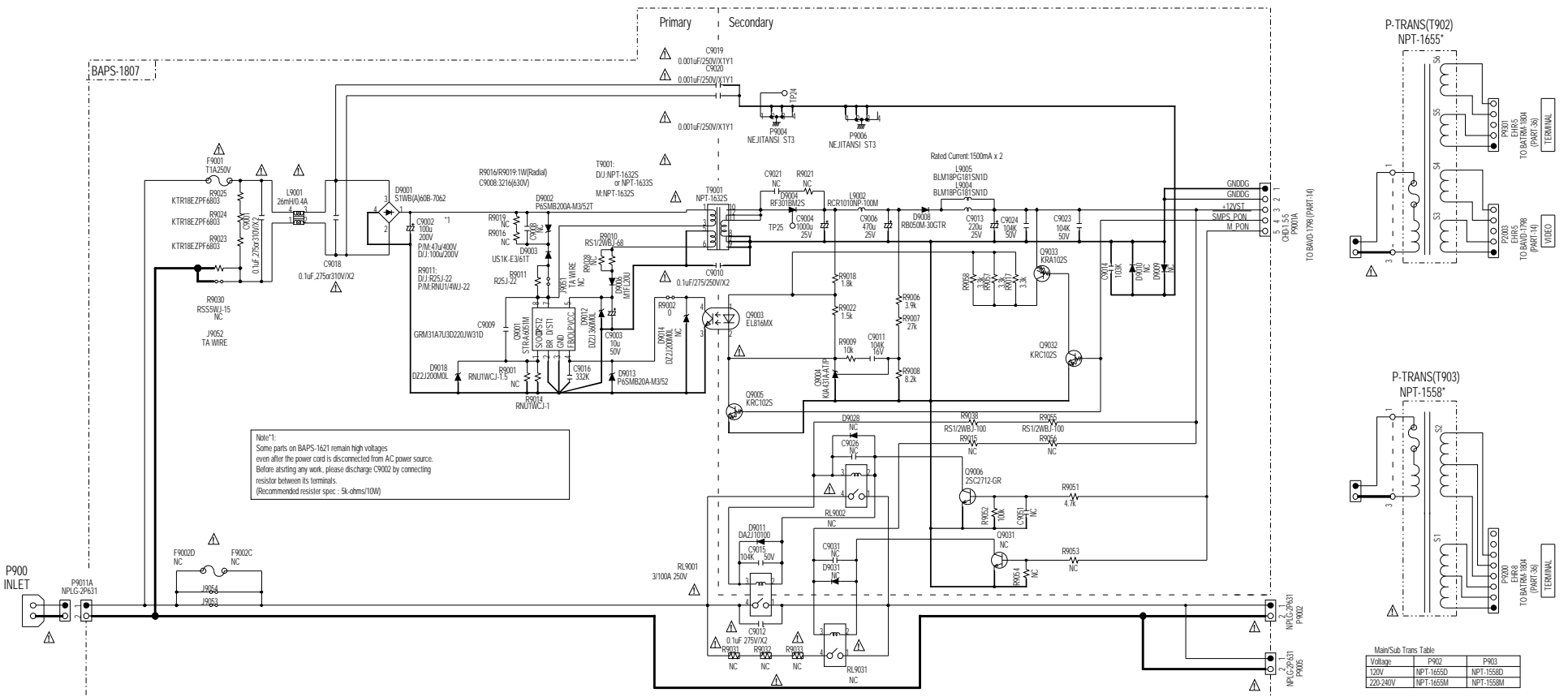

Note\*1:  
 Some parts on BAPS-1621 remain high voltages  
 even after the power cord is disconnected from AC power source.  
 Before starting any work, please discharge C9002 by connecting  
 resistor between its terminals.  
 (Recommended resistor spec: 5k-ohms/10W)

Main/Sub Trans Table

Voltage	P902	P903
120V	NPT-1655D	NPT-1558D
220-240V	NPT-1655M	NPT-1558M

MODEL NO.TX-RZ800/900/DTR-5 0.7/60.7/DHC-6 0.7  
BAPRC-1802 (1/10)

SCHEMATIC DIAGRAM (PART-35) MPU SECTION

H6PR 1:0 D  
1E:1 F  
P7000 B 0 1

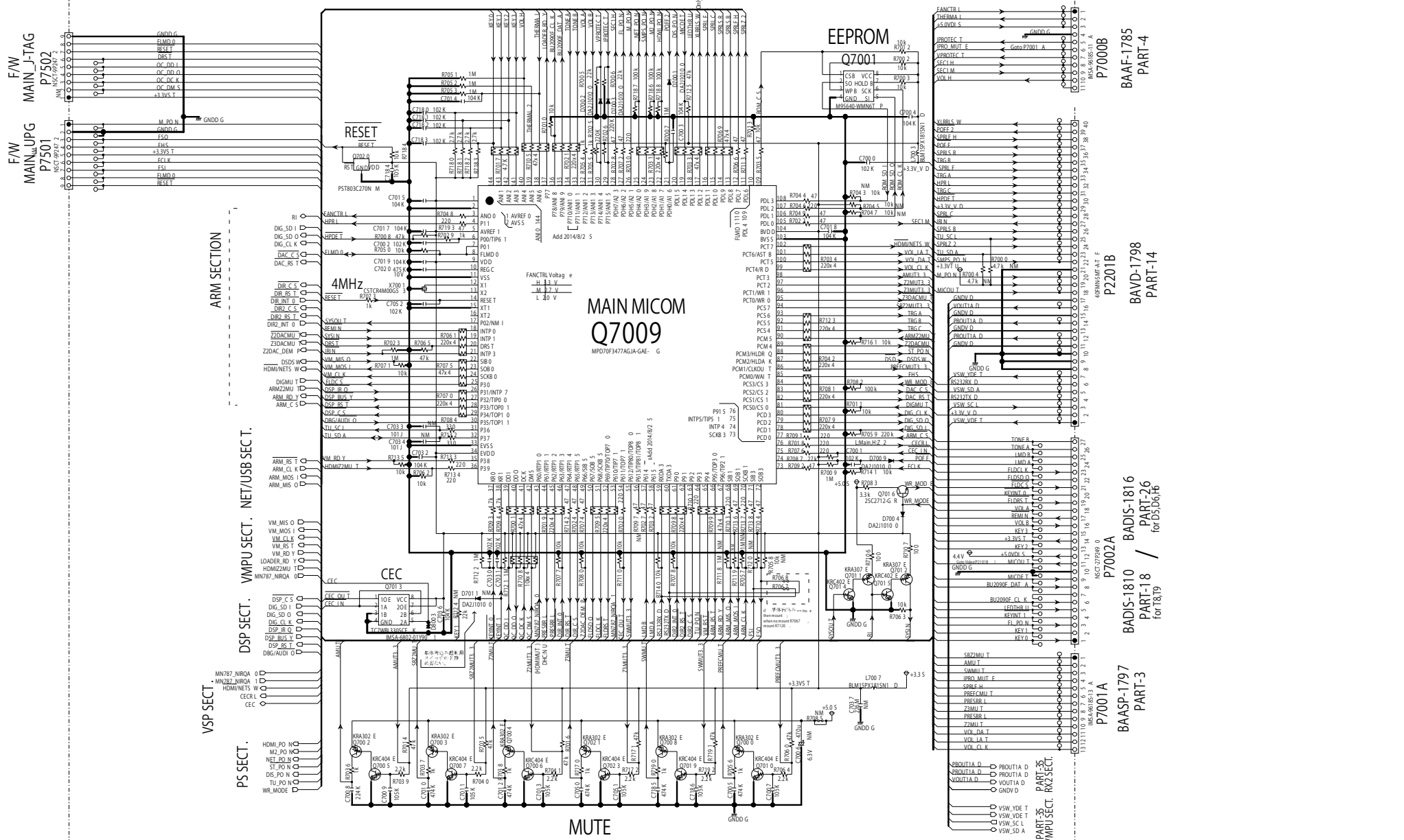

P7000B  
BAAF-1785  
PART-4

P2201B  
BAVD-1798  
PART-14

P7002A  
BADIS-1816  
PART-26  
for DS, D6, H6

P7001A  
BAASP-1797  
PART-3  
PART 25  
VMPU SECT.  
PART 26  
RAZ SECT.

P7001A  
BAASP-1797  
PART-3

P7001A  
BAASP-1797  
PART-3

MUTE

GND0 G

+3.3V T

+5.0V T

GND0 G

GND0 G

GND0 G

GND0 G

GND0 G

GND0 G

GND0 G

GND0 G

GND0 G

GND0 G

GND0 G

GND0 G

GND0 G

GND0 G

GND0 G

GND0 G

GND0 G

GND0 G

GND0 G

GND0 G

GND0 G

GND0 G

GND0 G

GND0 G

GND0 G

GND0 G

GND0 G

GND0 G

GND0 G

GND0 G

GND0 G

GND0 G

GND0 G

GND0 G

GND0 G

GND0 G

GND0 G

GND0 G

GND0 G

GND0 G

GND0 G

GND0 G

GND0 G

GND0 G

GND0 G

GND0 G

GND0 G

GND0 G

GND0 G

GND0 G

GND0 G

GND0 G

GND0 G

GND0 G

GND0 G

GND0 G

GND0 G

GND0 G

GND0 G

GND0 G

GND0 G

GND0 G

GND0 G

GND0 G

GND0 G

GND0 G

GND0 G

GND0 G

GND0 G

GND0 G

GND0 G

GND0 G

GND0 G

GND0 G

GND0 G

GND0 G

GND0 G

GND0 G

GND0 G

GND0 G

GND0 G

GND0 G

GND0 G

GND0 G

GND0 G

GND0 G

GND0 G

GND0 G

GND0 G

GND0 G

GND0 G

GND0 G

GND0 G

GND0 G

GND0 G

GND0 G

GND0 G

GND0 G

GND0 G

GND0 G

GND0 G

GND0 G

GND0 G

GND0 G

GND0 G

GND0 G

GND0 G

GND0 G

GND0 G

GND0 G

GND0 G

GND0 G

GND0 G

GND0 G

GND0 G

GND0 G

GND0 G

GND0 G

GND0 G

GND0 G

GND0 G

GND0 G

GND0 G

GND0 G

GND0 G

GND0 G

GND0 G

GND0 G

GND0 G

GND0 G

GND0 G

GND0 G

GND0 G

GND0 G

GND0 G

GND0 G

GND0 G

GND0 G

GND0 G

GND0 G

GND0 G

GND0 G

GND0 G

GND0 G

GND0 G

GND0 G

GND0 G

GND0 G

GND0 G

GND0 G

GND0 G

GND0 G

GND0 G

GND0 G

GND0 G

GND0 G

GND0 G

GND0 G

GND0 G

GND0 G

GND0 G



MODEL NO.TX-RZ800/900/DTR-50.7/60.7/DHC-60.7

SCHEMATIC DIAGRAM (PART-35) VMPU SECTION

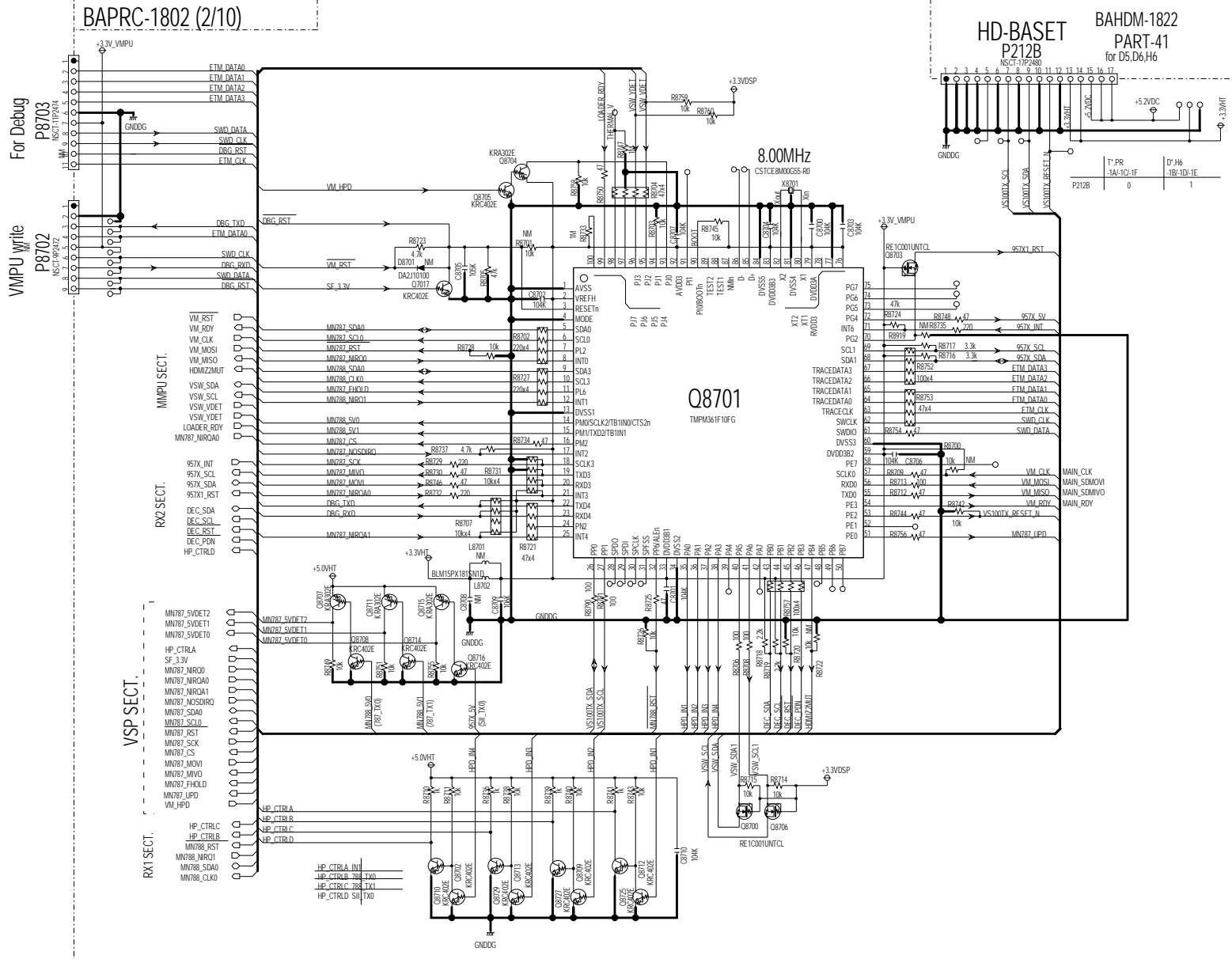





MODEL NO.TX-RZ800/900/DTR-50.7/60.7/DHC-60.7

SCHEMATIC DIAGRAM (PART-35) HDMI RX2 SECTION

BAPRC-1802 (5/10)

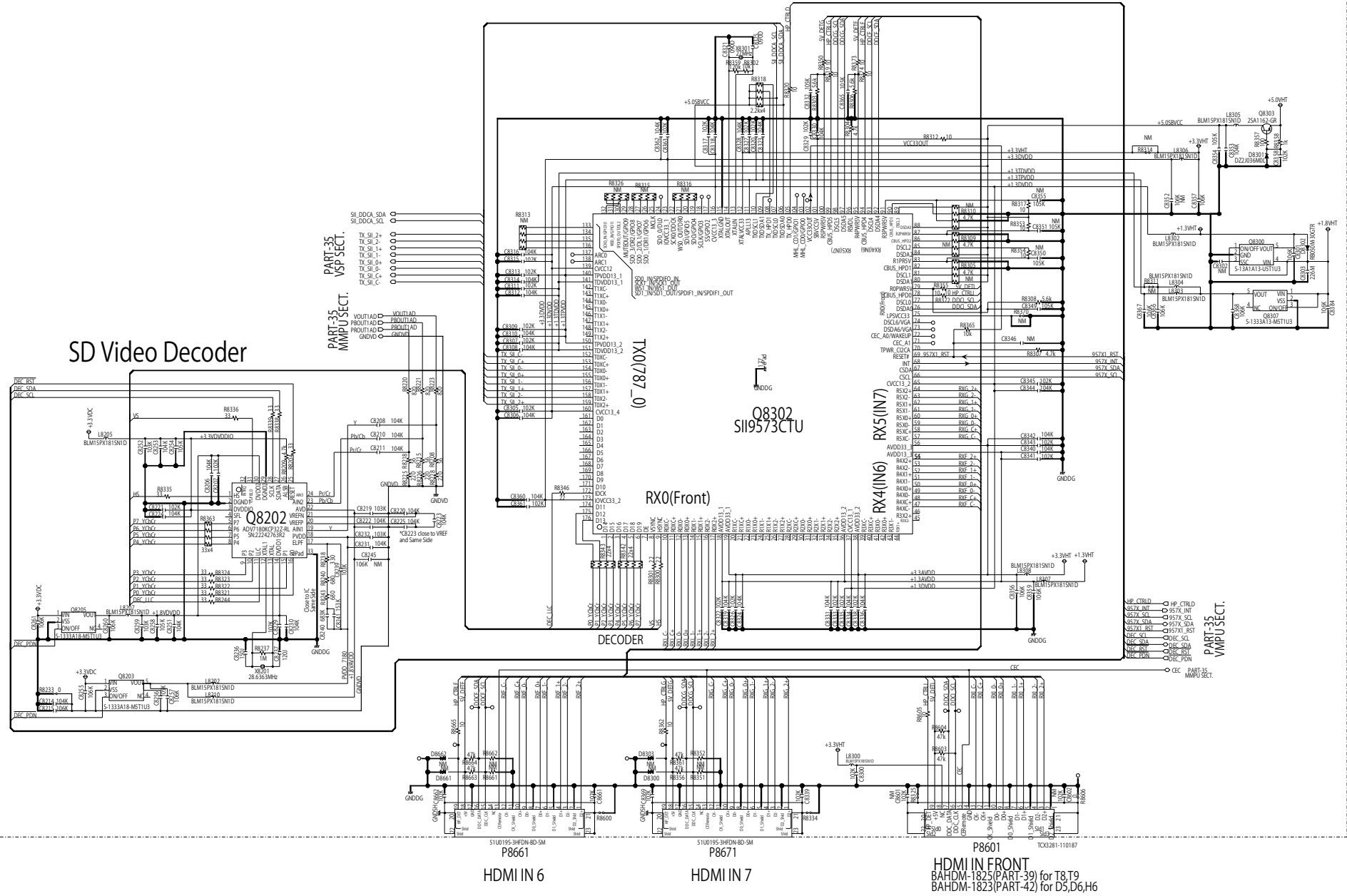

HDMI IN 6

HDMI IN 7

HDMI IN FRONT  
BAHDM-1825(PART-39) for T8,T9  
BAHDM-1823(PART-42) for D5,D6,H6

# NET/USB POWER SECTION

# Schematic Diagram

MODEL NO. TX-RZ800/900/DTR-50.7/60.7/DHC-60.7

SCHEMATIC DIAGRAM (PART-35)

NET/USB POWER SECTION

BAPRC-1802 (6/10)

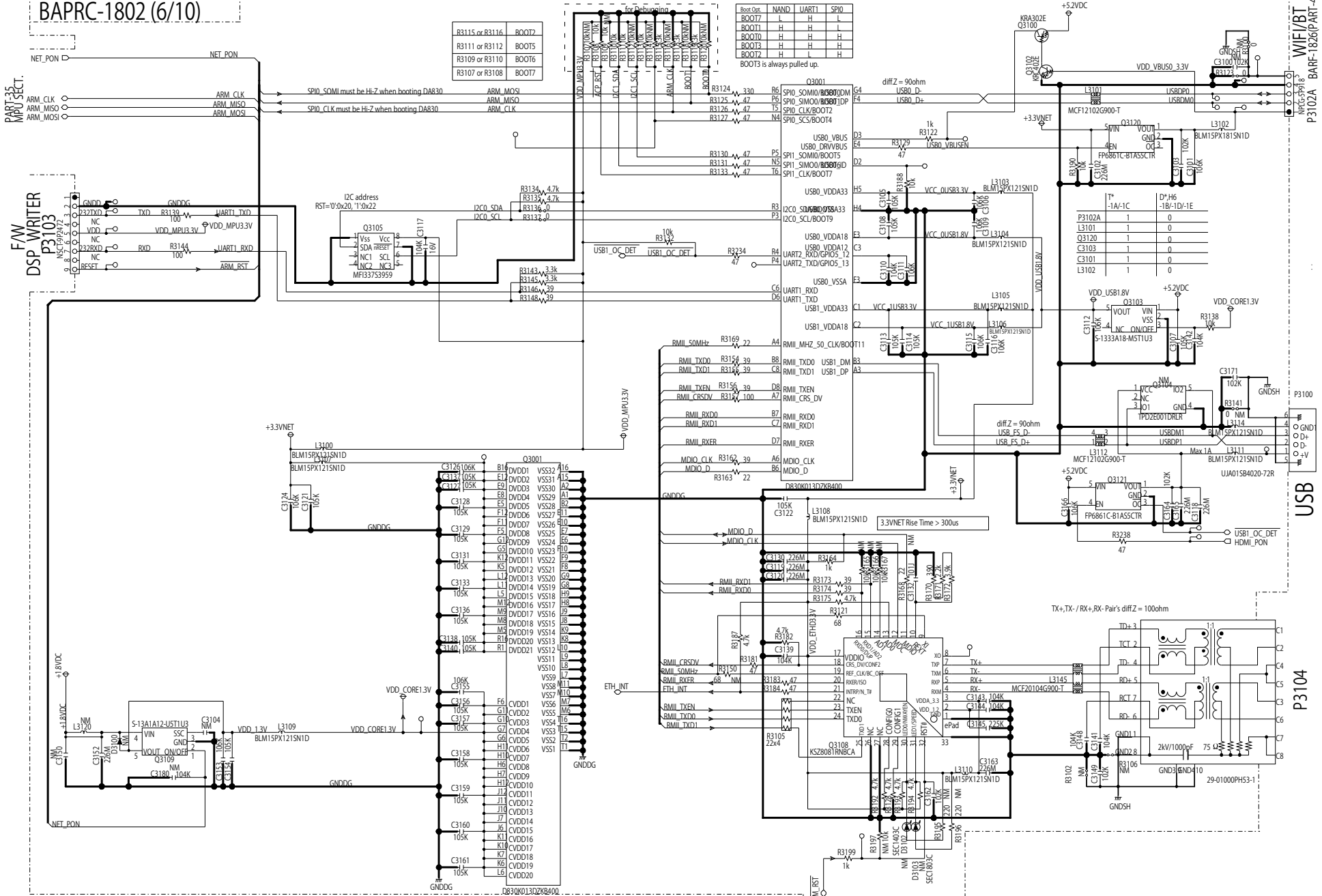

MODEL NO.TX-RZ800/900/DTR-50.7/60.7/DHC-60.7

SCHEMATIC DIAGRAM (PART-35)

ARM/ZoneDAC SECTION

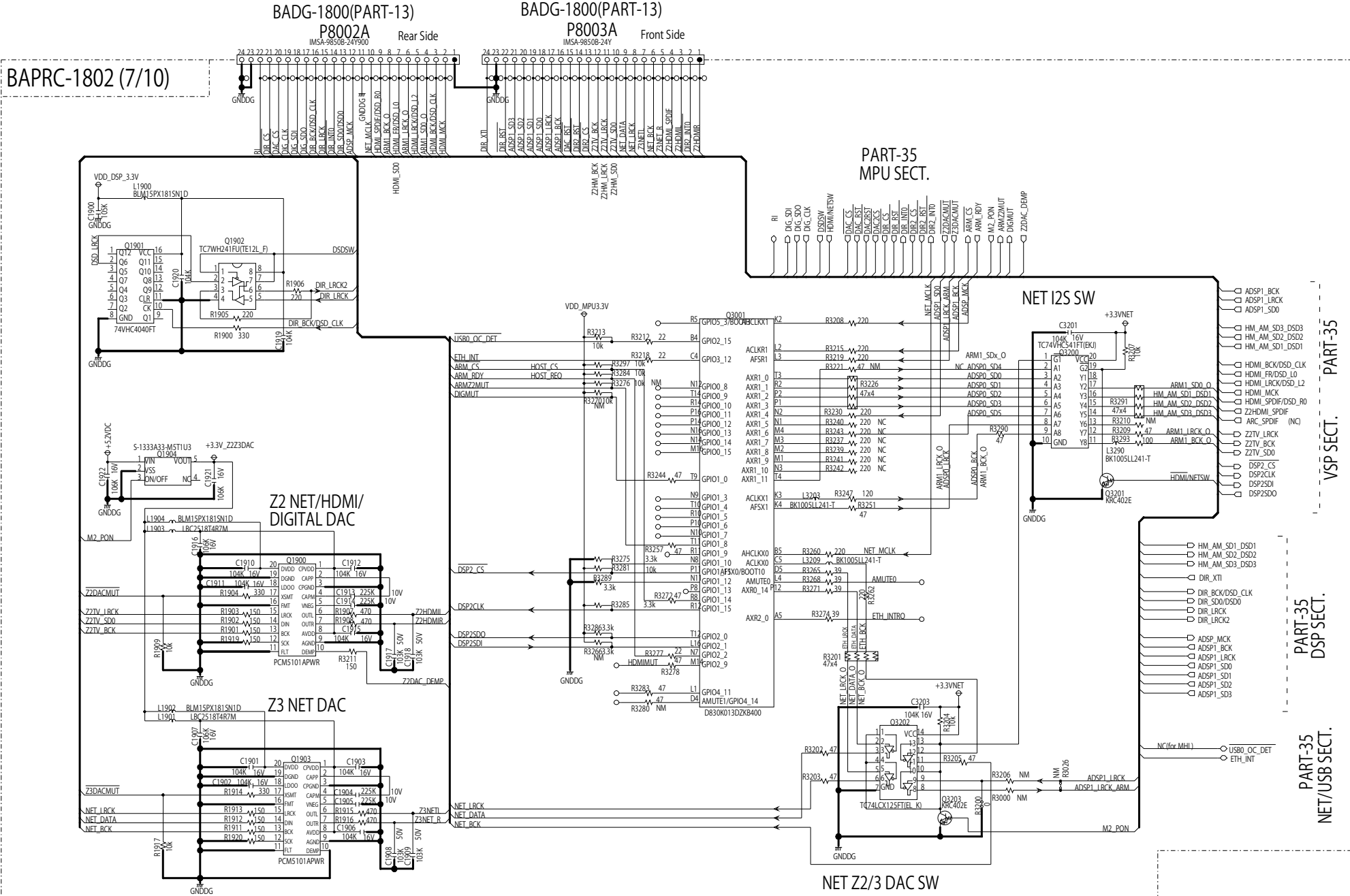

MODEL NO.TX-RZ800/900/DTR-50.7/60.7/DHC-60.7  
BAPRC-1802 (8/10)

SCHEMATIC DIAGRAM (PART-35)

ARM MEMORY SECTION

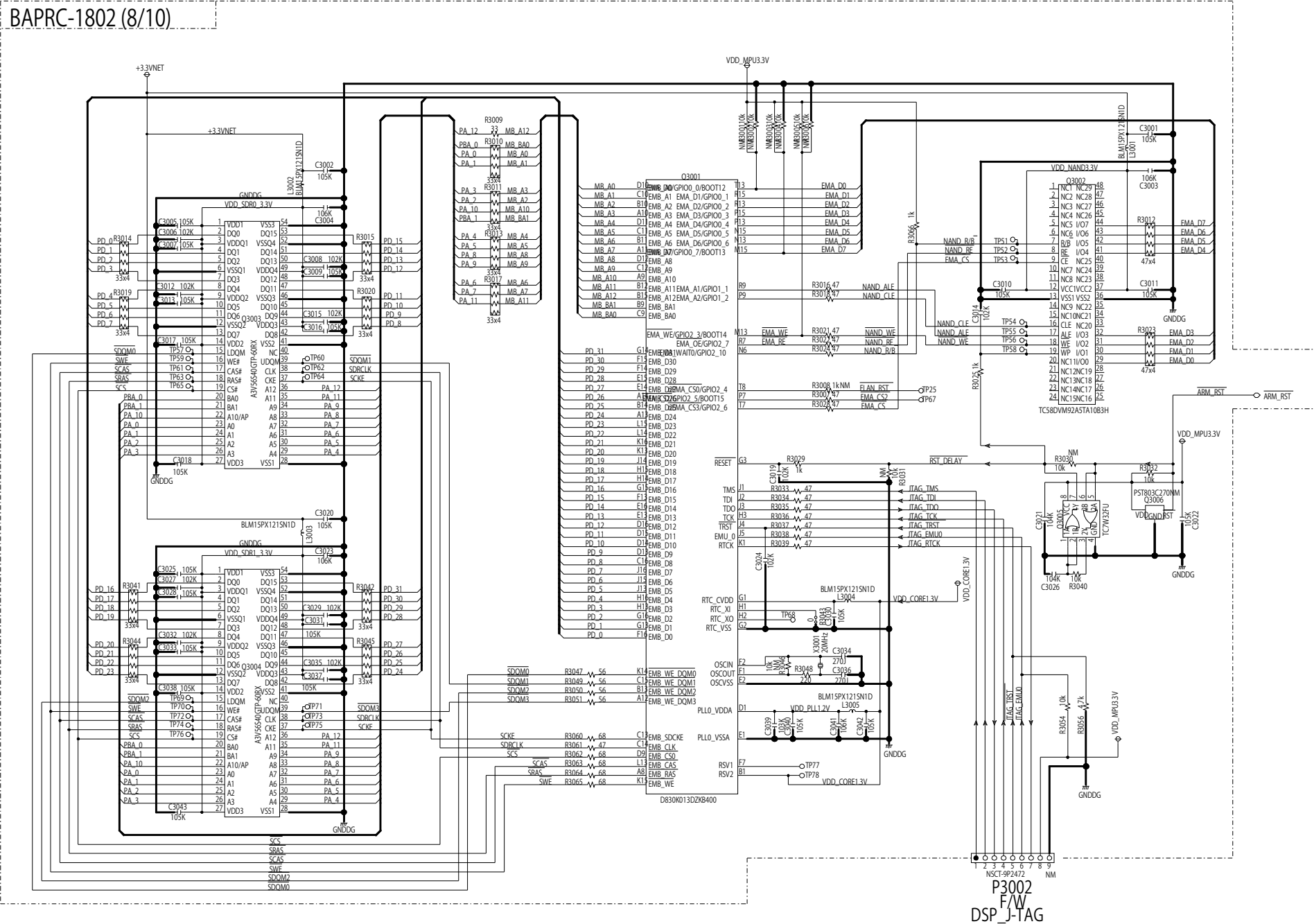

P3002  
F/W  
DSP\_J-TAG

MODEL NO.TX-RZ800/900/DTR-50.7/60.7/DHC-60.7  
BAPRC-1802 (9/10)

SCHEMATIC DIAGRAM (PART-35)

DSP SECTION

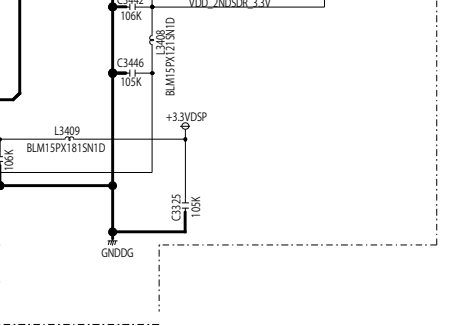
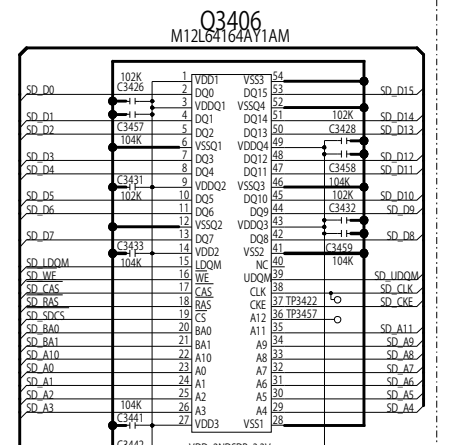
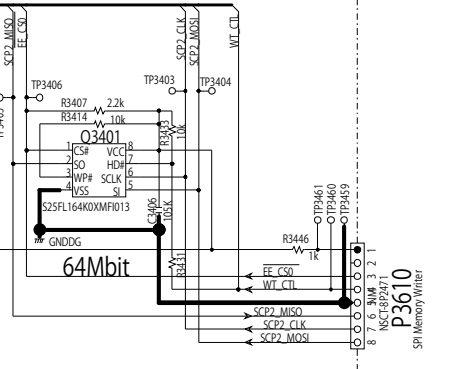
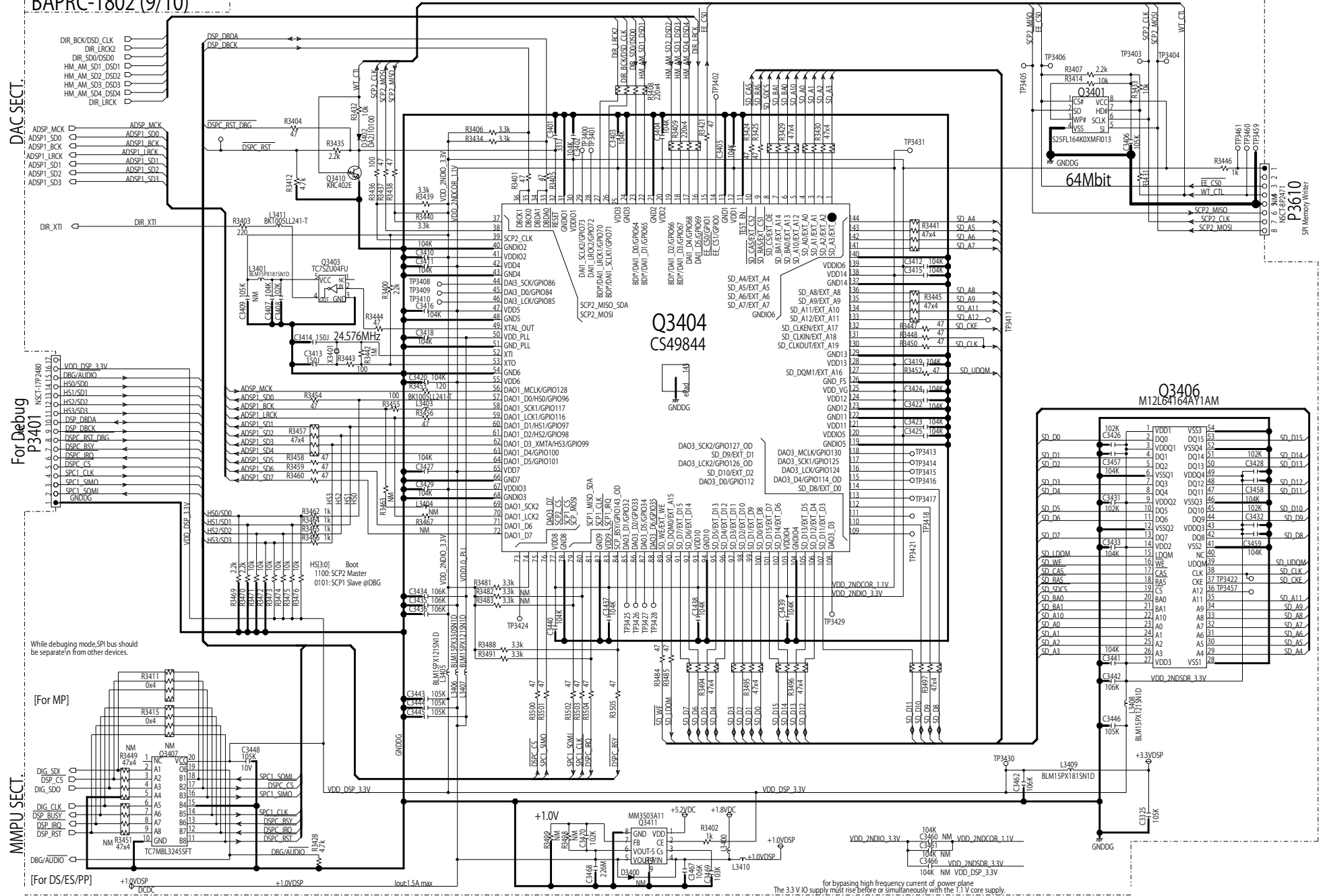

for bypassing high frequency current of power plane  
The 3.3V I/O supply must rise before or simultaneously with the 1.1V core supply.







Model No. DHC-60.7 SCHEMATIC DIAGRAM (PART-36)

Balance In/OUT SECTION

BATRM-1804

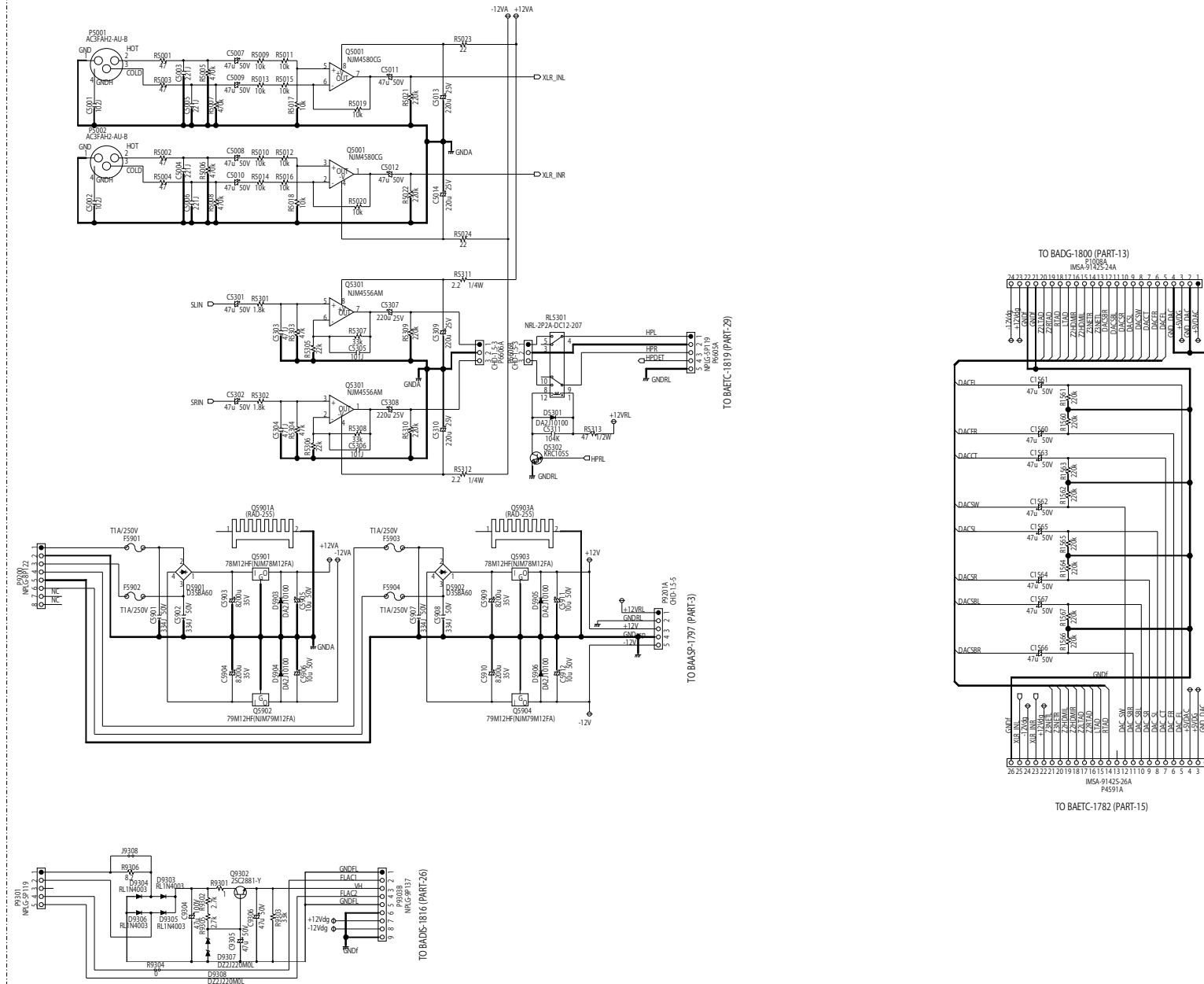

MODEL NO.DHC-60.7 SCHEMATIC DIAGRAM(PART-37) BALANCE OUT SECTION

BAAE-1806

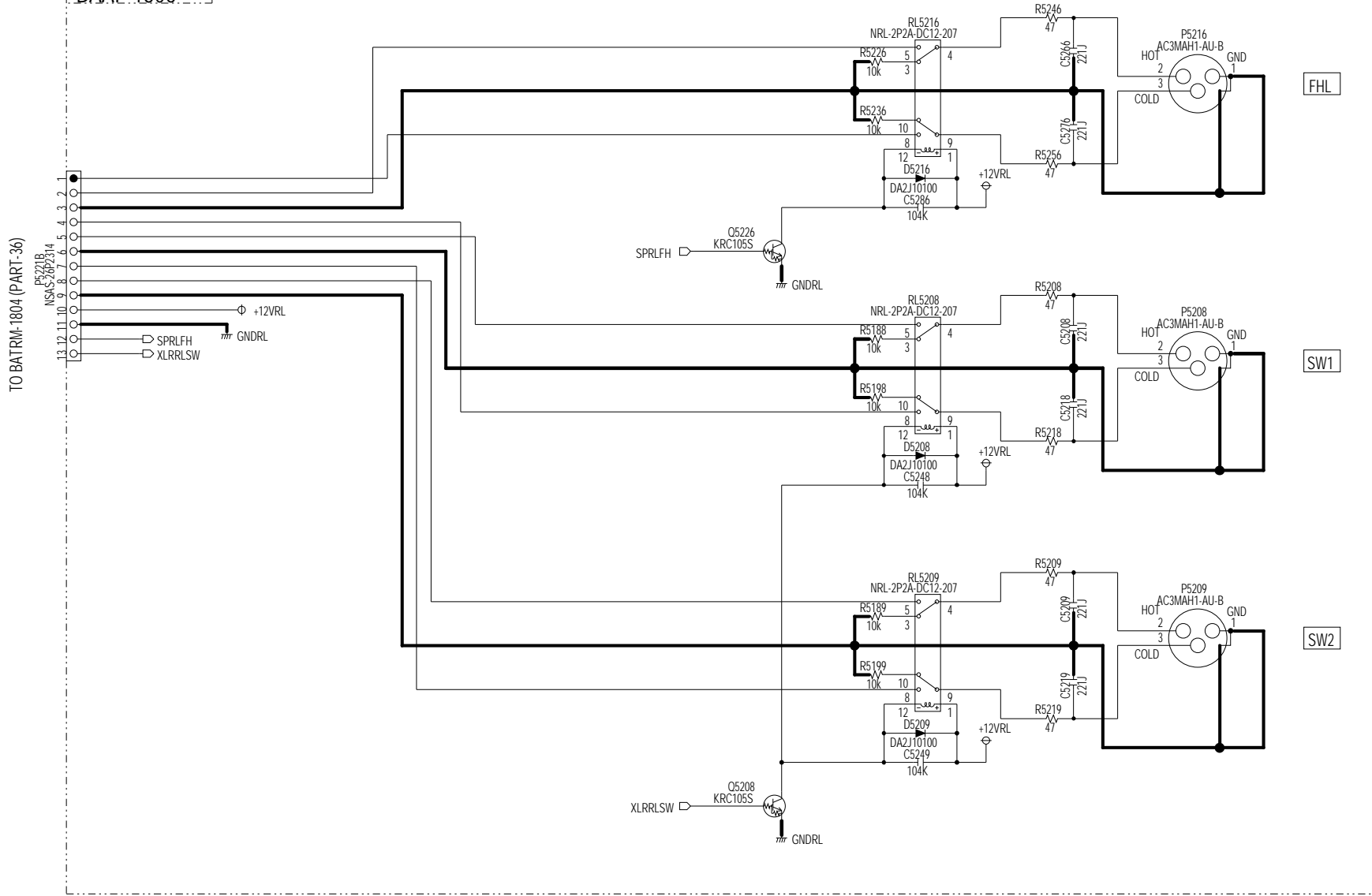

TO BATRM-1804 (PART-36)

P5216  
NSAS:26P2314

- 1
  - 2
  - 3
  - 4
  - 5
  - 6
  - 7
  - 8
  - 9
  - 10
  - 11
  - 12
  - 13
  - 14
- Φ +12VRL  
SPRLFH  
GNDRL  
XLRRLSW

FHL

SW1

SW2



# MODEL NODHC-60.7 SCHEMATIC DIAGRAM(PART-38)

BAETC-1808

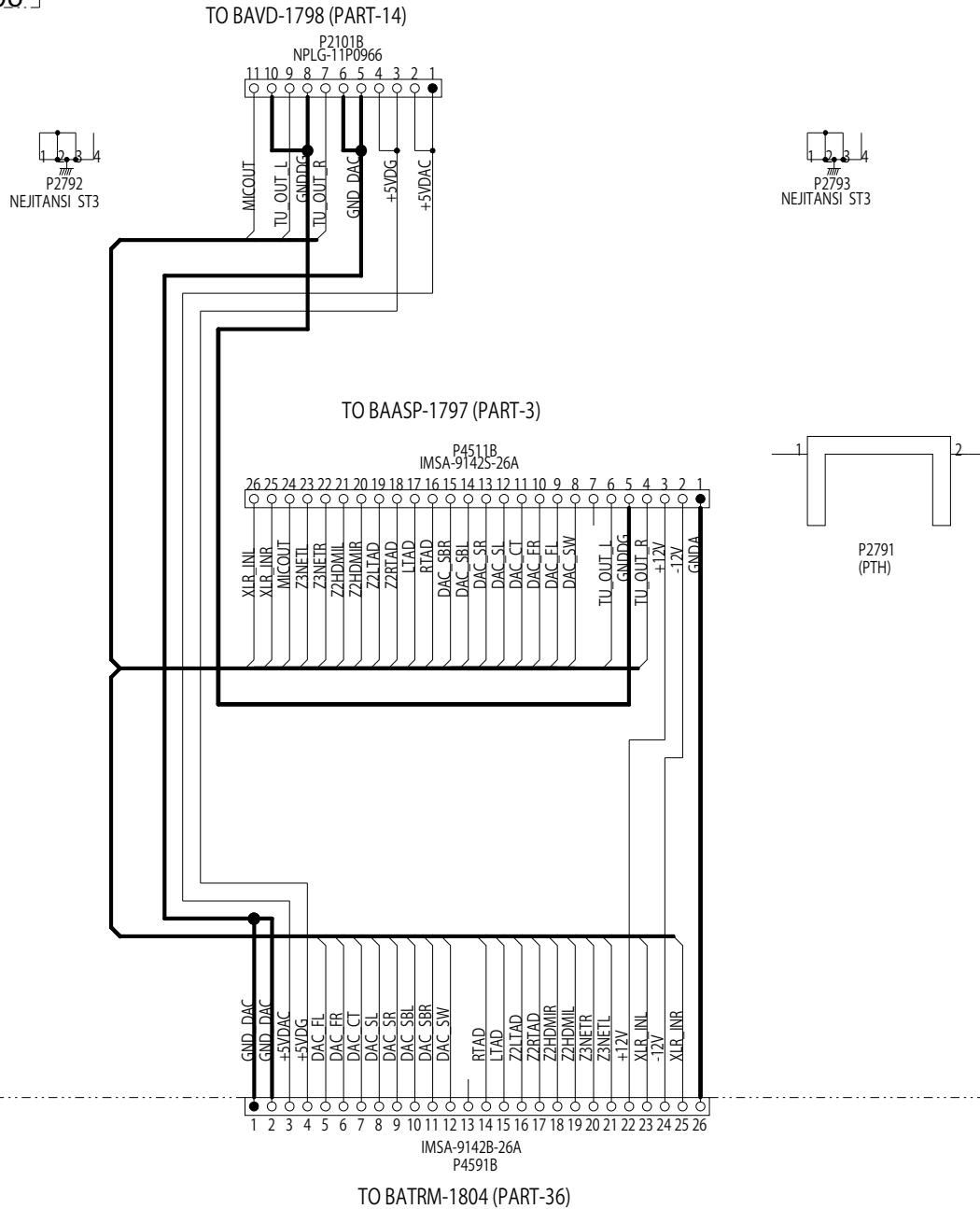

MODEL NO.TX-RZ800/900  
SCHEMATIC DIAGRAM (PART-39) FRONT HDMI SECTION

BAHDM-1825

	1A	1B	1C	1D
P8504	0	0	1	1
P8502	1	1	0	0

FRONT HDMI IN

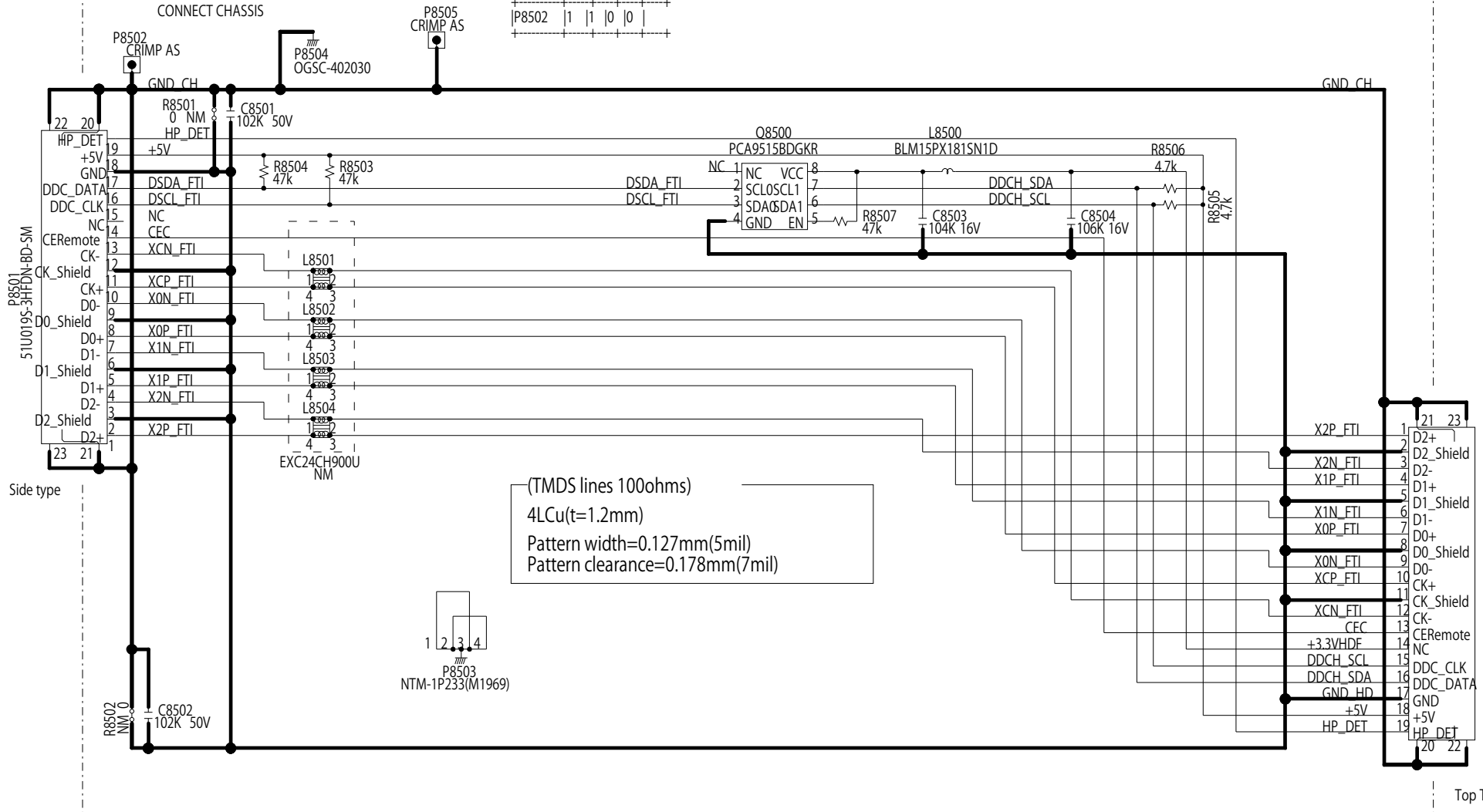

(TMD5 lines 100ohms)  
4LCu(t=1.2mm)  
Pattern width=0.127mm(5mil)  
Pattern clearance=0.178mm(7mil)

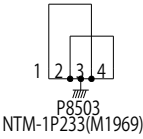

P8500  
TCX3255-011187

BAPRC-1802  
(Part-35)

Top Type







MODEL NO.DTR-50.7/60.7,DHC-60.7(PART-41)

SCHEMATIC DIAGRAM HDBaseT SECTION

BAHDM-1822(2/3)

HDBaseT HDMI IN

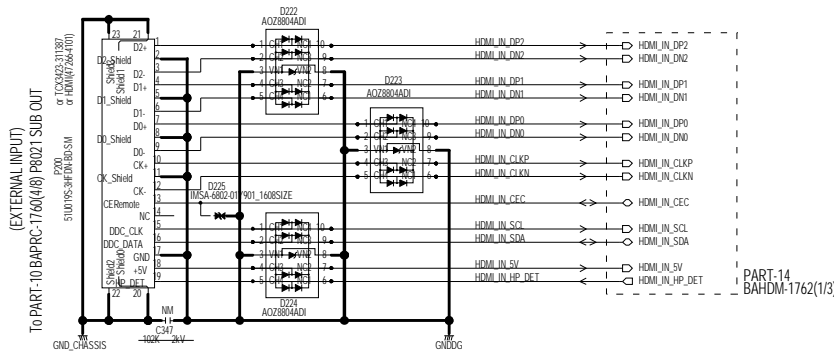

PART-14 BAHDM-1762(1/3)

HDBaseT GPIO

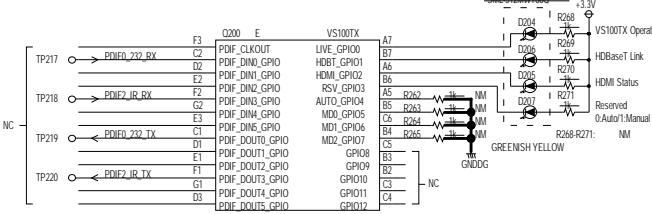

POWER SUPPLY

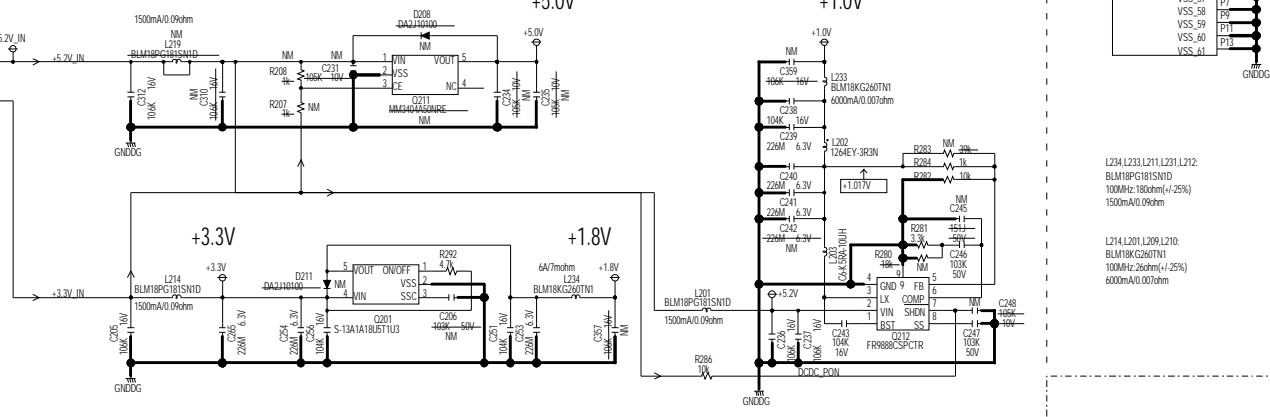

MODEL NO.DTR-50.7/60.7,DHC-60.7(PART-41)

SCHEMATIC DIAGRAM HDBaseT SECTION

BAHDM-1822(3/3)

\*All parts is NM.

HDBaseT POH SECTION

DC + 2.4V 仕様の場合は部品変更箇所有り  
C403/C406:332101045R1 CK725B1H-104K1(0.1uF/50V)

[MEDIA SIDE]

AC ADAPTER:  
選定中  
+50Vdc/600mA  
(+47.5V ~ +52.5V)  
or  
+24Vdc/1000mA  
(+24V ?)

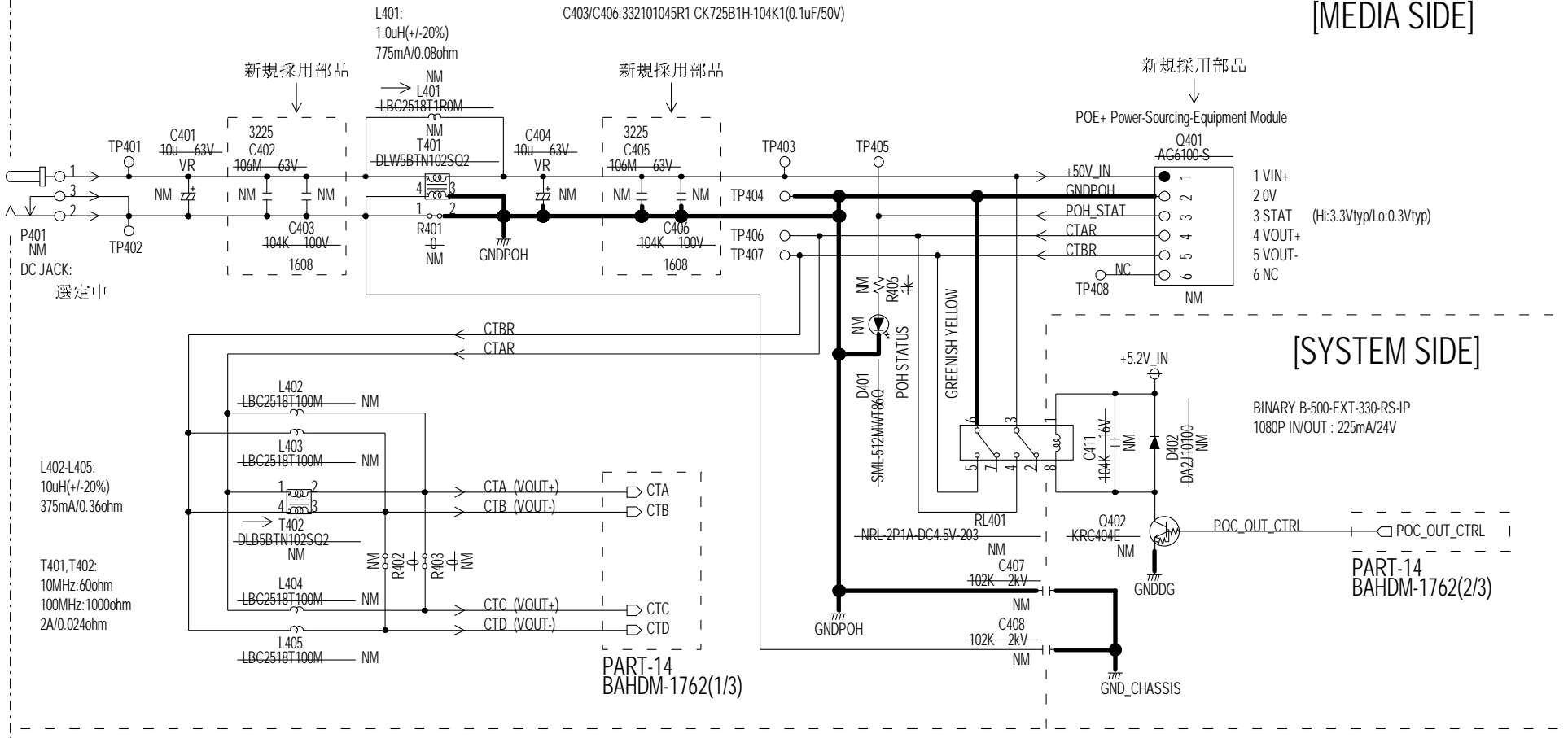

POE+ Power-Sourcing-Equipment Module

Q401  
AG6100-S

1 VIN+  
2 0V  
3 STAT (Hi:3.3Vtyp/L0:0.3Vtyp)  
4 VOUT+  
5 VOUT-  
6 NC

[SYSTEM SIDE]

BINARY B-500-EXT-330-RS-IP  
1080P IN/OUT : 225mA/24V

POC\_OUT\_CTRL

PART-14  
BAHDM-1762(1/3)

PART-14  
BAHDM-1762(2/3)

MODEL NO. DTR-50.7/60.7,DHC-60.7  
SCHEMATIC DIAGRAM (PART-42) FRONT HDMI SECTION

BAHDM-1823

FRONT HDMI IN

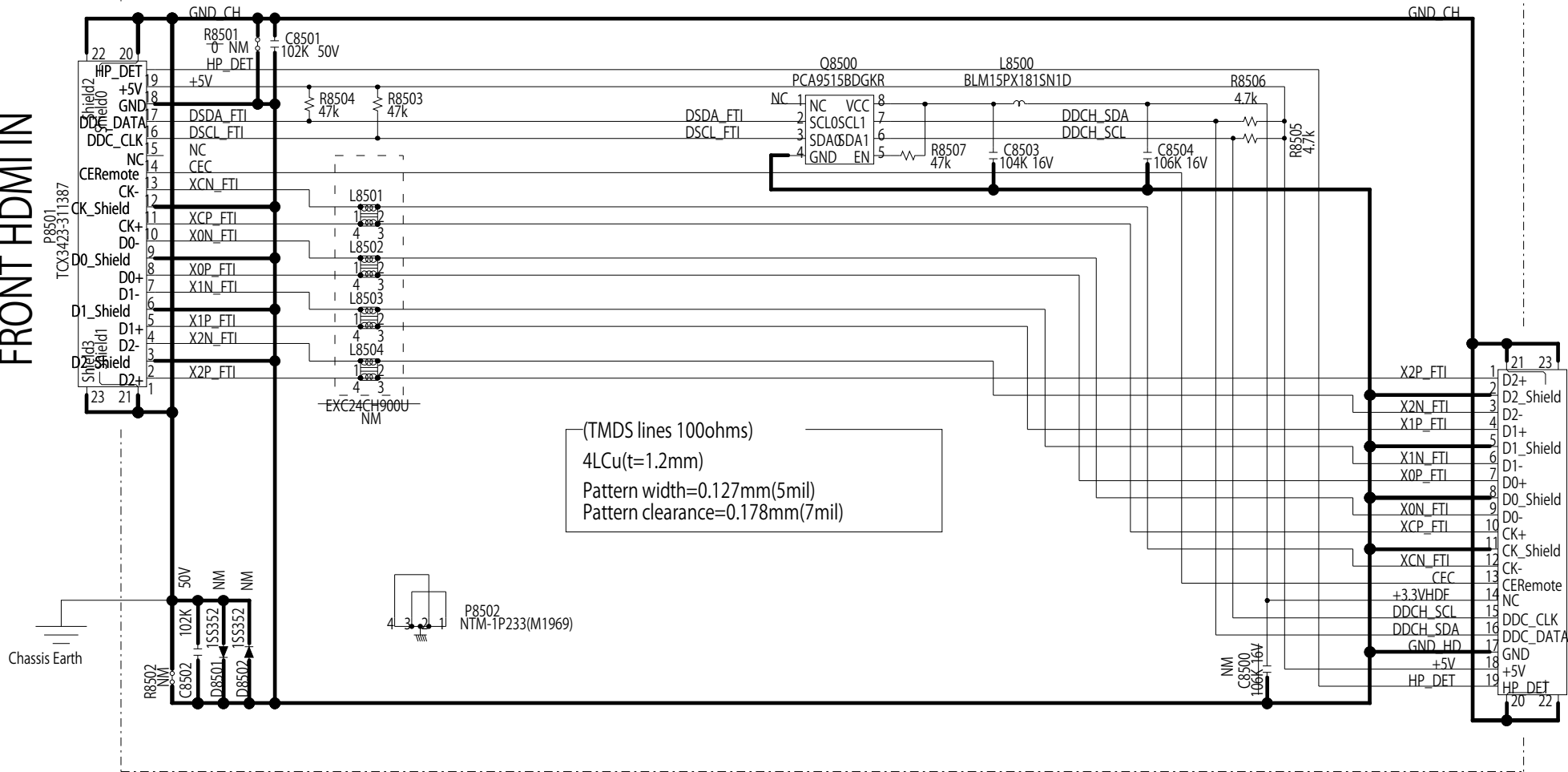

P8500 TCX3255-011187

BAPRC-1802 (Part-35)

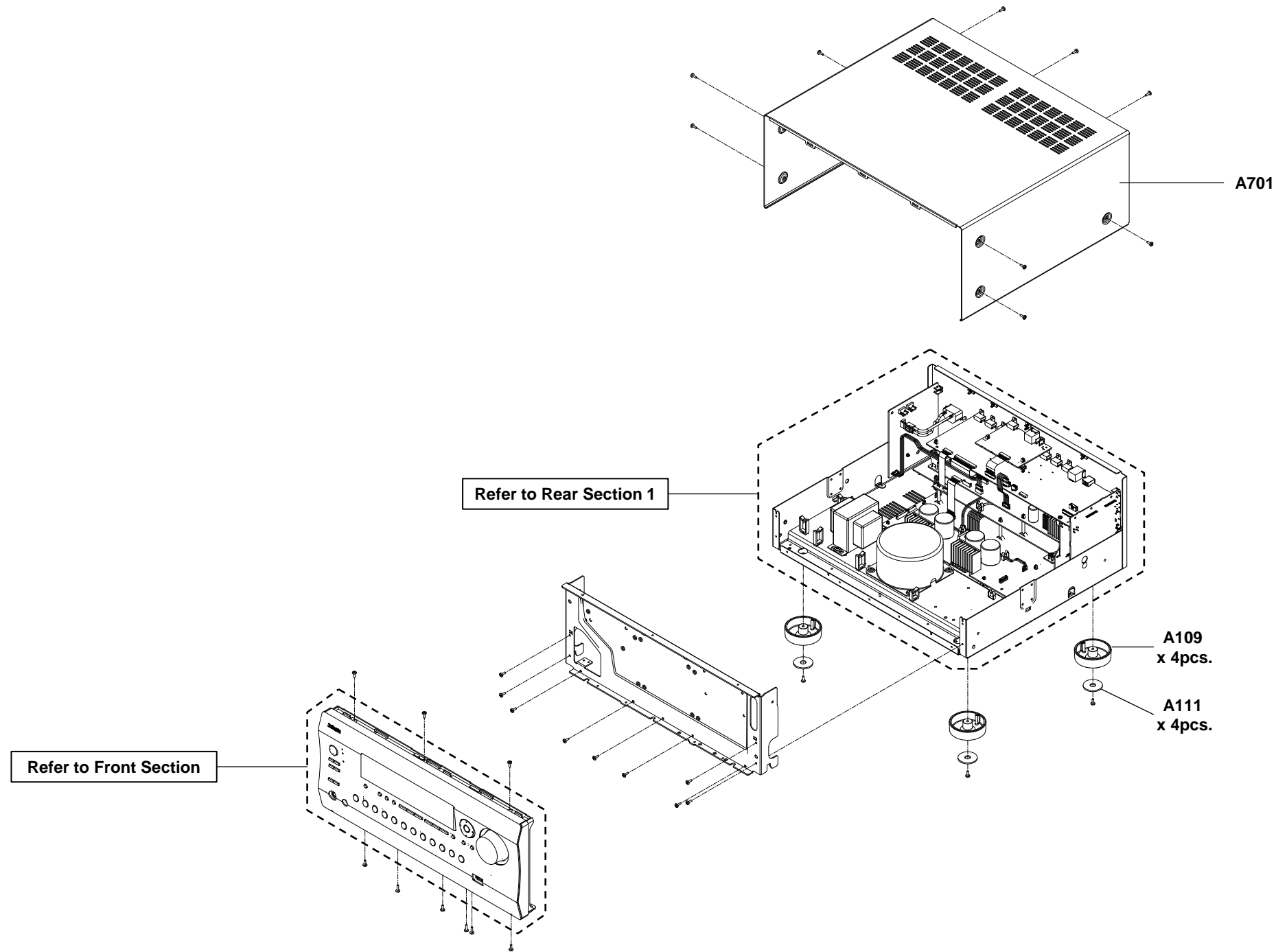

Front Section

Exploded View

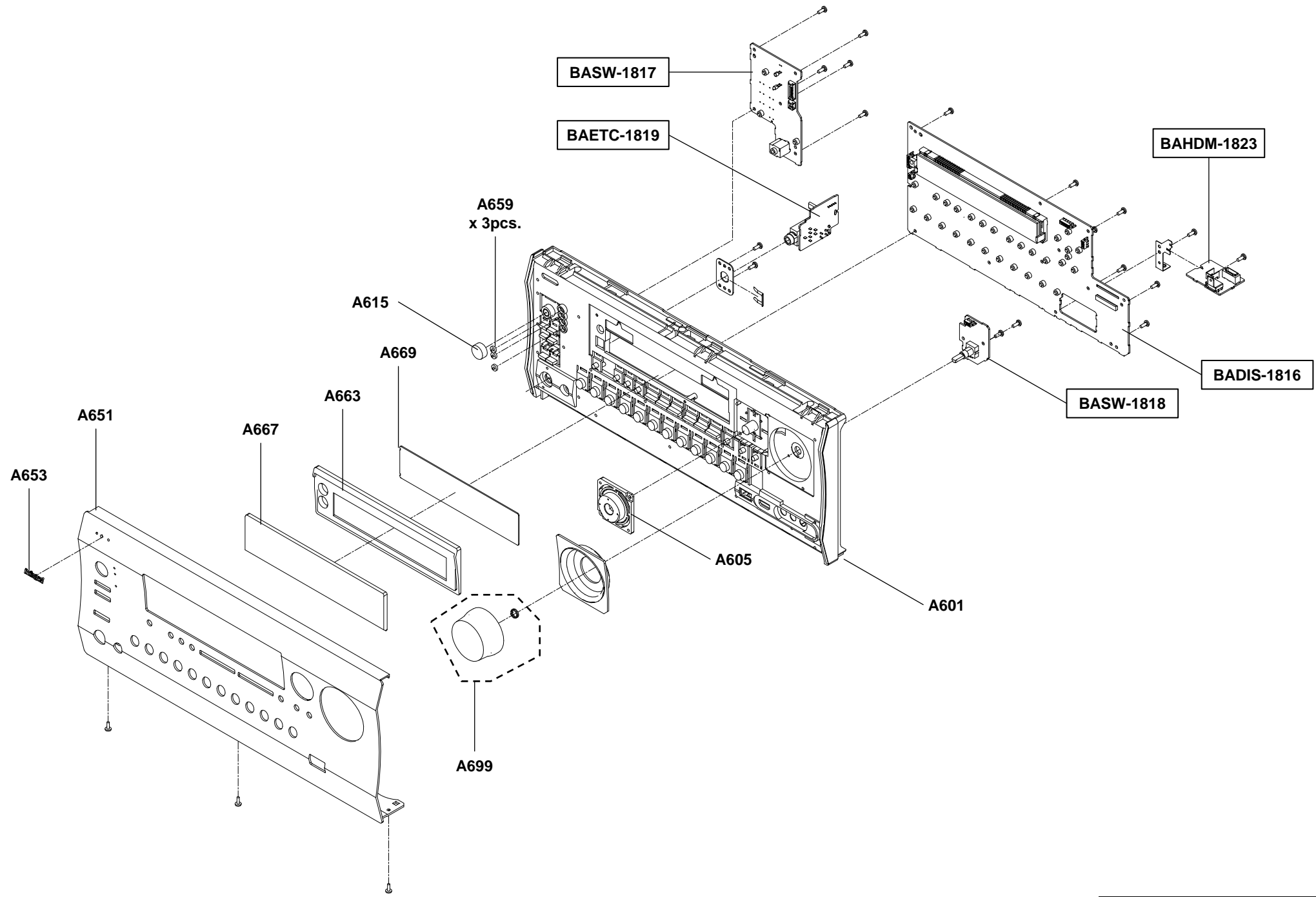

Rear Section 1

Exploded View

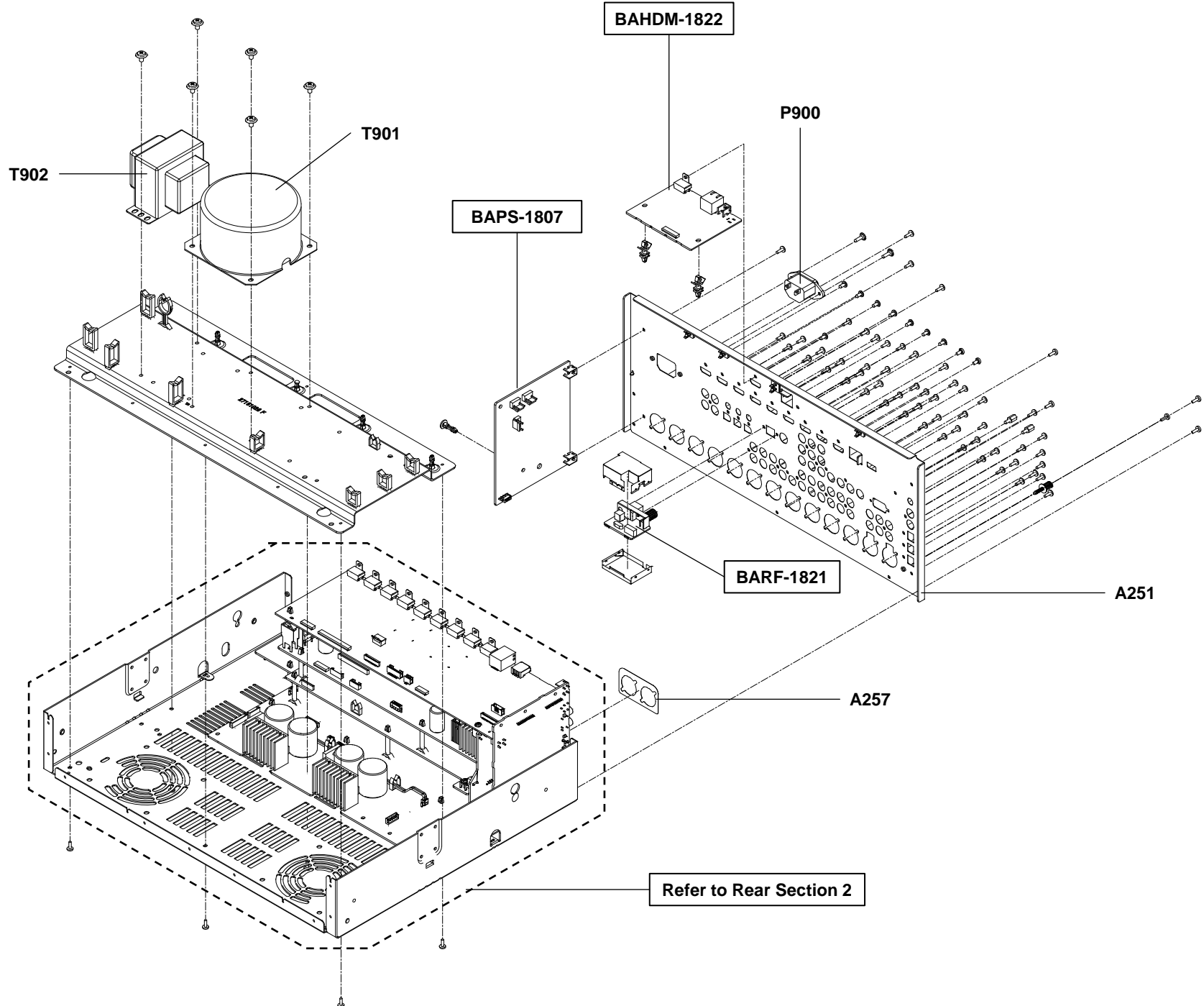

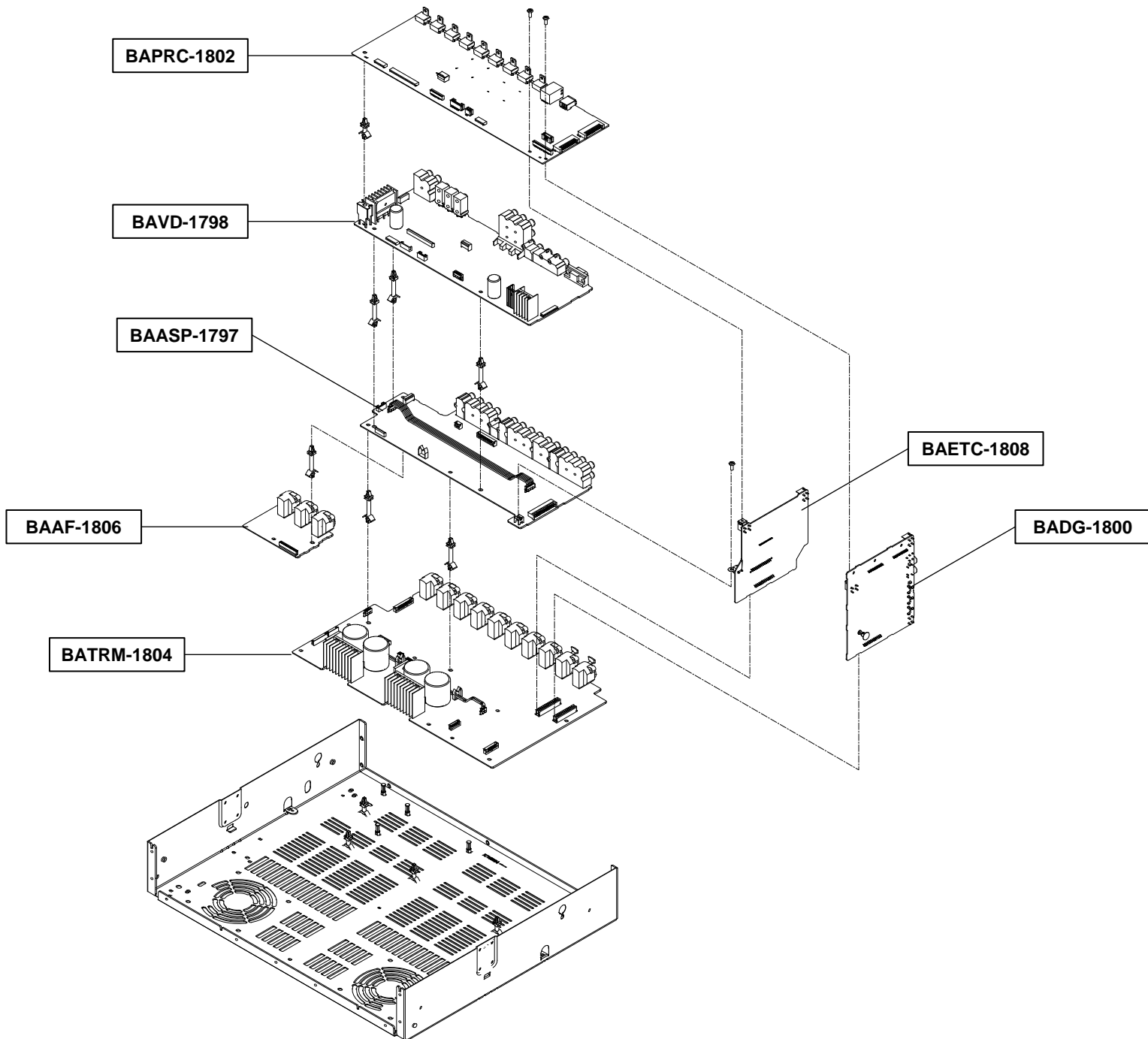

# Operation check

## About Button Action

Use the following expression simplify description button operation.

Example-1 : [TV/CD] + [ON/STANDBY] → [BD/DVD]

Means press and hold [ON/STANDBY] while pressing [TV/CD] button, then press [BD/DVD] button.

Example-2 : [DISPLAY] + [ON/STANDBY] x 2 → [DIMMER] or [RT/PTY/TP]

Means press and hold [ON/STANDBY] button two times while pressing [DISPLAY] button, then press [DIMMER] or [RT/PTY/TP] button.

## How to check MAIN Checksum

### Step1

Set the volume level as 30.

### Step2

[DISPLAY] + [ON/STANDBY] x 2 → [ENTER]

## How to check FL Tube and LED Operation

### Step1

Set the volume level as 30.

### Step2

[TV] + [ON/STANDBY] → [DIMMER] or [RT/PTY/TP]

## How to check Output Sensor & Temperature Sensor

[DISPLAY]+ [ON/STANDBY] x 2 → [TONE] key

[例] 001 042 F:xS:H

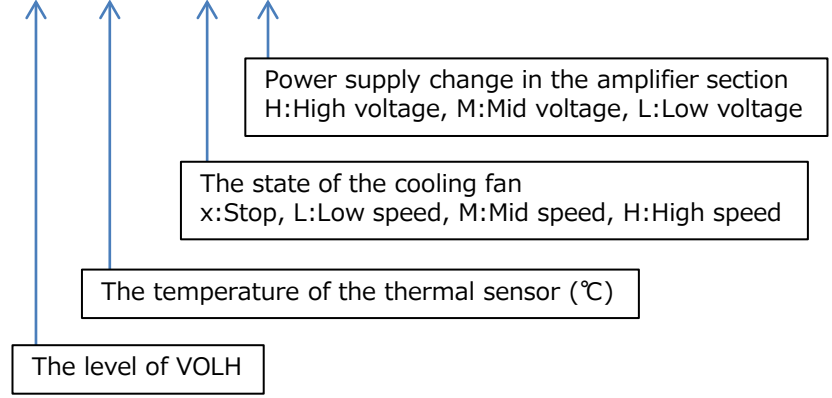

## Initial Setting for Shipping (Service Information is also cleared.)

### Step1

Set the volume level as 30.

### Step2

[TONE] + [ON/STANDBY] → [Return] x 2  
Display "All Clear" of FL tube and AVR goes standby.

### Step3

Unplug the power cord



# Operation check

## How to check Output Sensor

\*When this check is 'NG', retry it after power-off.

### Low Detect check (Power Trams TAP : LOW, Fan speed : LOW )

When set the following test mode , if FL tube display "OK" then this check is passed.

Test mode (TEST 1-07)	Set the volume level as 30. [ TV ] + [ ON/STANDBY ] → [ CBL/SAT ] → [ TONE - ] x 3
Relay	RL6903/6904 RL6901/6902(TX-RZ900/DTR-60.7only)
Fan	Low speed

### High Detect check (Power Trams TAP : HIGH, Fan speed : HIGH)

When set the following test mode , if FL tube display "OK" then this check is passed.

Test mode (TEST 1-08)	Set the volume level as 30. [ TV ] + [ ON/STANDBY ] → [ CBL/SAT ] → [ TONE - ] x 2
Relay	RL6903/6904 RL6901/6902(TX-RZ900/DTR-60.7only)
Fan	High speed

### Mid Detect check (Power Trams TAP : MID, Fan speed : MID )

※) This test is TX-RZ900 and DTR-60.7 only.

When set the following test mode , if FL tube display "OK" then this check is passed.

Test mode (TEST 1-06)	Set the volume level as 30. [ TV ] + [ ON/STANDBY ] → [ CBL/SAT ] → [ TONE - ] x 4
Relay	RL6901/6902/6903/6904(TX-RZ900/DTR-60.7only)
Fan	Mid speed(TX-RZ900/DTR-60.7only)

## How to check buttons and Master Volume Operation

**Step1** : Set the following test mode and confirm each buttons and master volume operation.

Test mode (TEST 1-05)	Set the volume level as 30. [ TV ] + [ ON/STANDBY ] → [ CBL/SAT ] → [ TONE - ] x 5
--------------------------	---

**Step2** : If "ON/STANDBY" button is pressed, AVR escapes from this button test mode.

Therefore, press the "ON/STANDBY" button, after checking other buttons finished.

## How to check FL Display

**Step1** : Set VOL Level = 30

**Step2** : [TV] + [ON/STANDBY] → [DIMMER] or [RT/PTY/TP]

Lit all Segment.

**Step3** : [TONE +]

Lit '23456789ABCDEF'.

**Step4** : [TONE +]

Lit a even number segment.

**Step5** : [TONE +]

Lit an odd number segment.

**Step6** : [TONE +]

The Destination setting is displayed.

# Debug Mode

## Audio debug mode

The operations of DSP and DIR etc. are able to checked by the information displayed on FL in this debug mode. This information will help to analysing digital audio no sound trouble.

### How to enter to a audio debug mode

**Step1** : [DISPLAY] + [ON/STANDBY] x 2

Display "Mx.xx / xxxxxxxx" --- Version number of MPU

**Step2** : [DISPLAY]

Display "Nx.xx / xxxxxxxx" --- Version number of N or DA830/NET

**Step3** : [DISPLAY]

Display Audio debug information

**Step4** : [TONE+] = forward, [TONE-] =reverse

### FL Display

1	1	2	2	3	3	:	A	A	:	B	B		
C	C	C	:	:		E	E	E	:	F	:	G	

[TONE+]↓

↑[TONE-]

1	:	1	1	1	1	2	2	2	k	3	3	3	k
4	4	4	.	5	:	6	6	6	6	:	7	7	7

[TONE+]↓

↑[TONE-]

2	:	8	:	9	9	9	9	:	10	10	10	10	
	11	11	:	12	:	13	:	14	14	14		15	15

# Debug Mode

1	1	2	2	3	3	:	A	A	:	B	B		
C	C	C	:	:		E	E	E	:	F	:	G	

01	C_LM_LAST
02	C_LM_PURE
03	C_LM_DIRECT
04	C_LM_STEREO
05	C_LM_MONO
20	C_LM_SURR
50	C_LM_THX_MUSIC
70	C_LM_THX_GAME
90	C_LM_THX_CINEMA
A0	C_LM_THX_U2GAME
A8	C_LM_THX_U2MUSIC
B0	C_LM_THX_U2CINEMA
D0	C_LM_AUDYSSEY
48	C_LM_DTSSS
06	C_LM_ORCHESTRA
07	C_LM_UNPLUGGED
08	C_LM_STUDIOMIX
09	C_LM_TVLOGIC
0A	C_LM_ALLCHST
0B	C_LM_FULLMONO
0C	C_LM_TD
F1	C_LM_TESTTONE
F2	C_LM_TESTTHR
F3	C_LM_TESTAUTO
F4	C_LM_ASC
F5	C_LM_FLASH
F6	C_LM_DEBUGMODE
F7	C_LM_FLASH2
F8	C_LM_FLASH3
F9	C_LM_FLASH4
FA	C_LM_FLASH_CHECK
0D	C_LM_RPG
0E	C_LM_ACTION
0F	C_LM_ROCKBAND
10	C_LM_SPORTS

00	C_EXTDEC_OFF
01	C_EXTDEC_20_PLII
02	C_EXTDEC_20_PLIIX
03	C_EXTDEC_20_PLIIZ
04	C_EXTDEC_20_NEO6
05	C_EXTDEC_51_MTR
06	C_EXTDEC_51_DSC
07	C_EXTDEC_51_NEO6
08	C_EXTDEC_51_EX
09	C_EXTDEC_51_PLIIX
0A	C_EXTDEC_51_PLIIZ
0B	C_EXTDEC_9624
0C	C_EXTDEC_9624_MTR
0E	C_EXTDEC_71MULTI
0F	C_EXTDEC_20_NEURAL
10	C_EXTDEC_51_NEURAL

00	C_EXTDECMD_OFF
01	C_EXTDECMD_10
02	C_EXTDECMD_20
03	C_EXTDECMD_MOVIE
04	C_EXTDECMD_MUSIC
05	C_EXTDECMD_GAME
06	C_EXTDECMD_HEIGHT
07	C_EXTDECMD_WIDE

<b>A</b>	ミュートポート状態
D	DIGMUTEポート
A	AMUTEポート

<b>B</b>	
bit_1	SELMUTE
bit_2	POWMUTE
bit_3	PROTECTMUTE
bit_4	AUDIOOUTMUTE
bit_5	AUDIOMUTE

<b>C</b>	現在の入力端子
ANA	Analog
COX	Caxal
OPT	Optical
HDM	HDMI
ARC	ARC

<b>E</b>	
STB	SOUND STATE FIX
TRS	SOUND STATE UNFIX
NON	SOUND STATE NONE

<b>F</b>	
S	display_inhibit SET
C	display_inhibit CLR

<b>G</b>	
V	HDMI MUTE

# Appendix

# Debug Mode

# Appendix

1	:	1	1	1	1	2	2	2	k	3	3	3	k
4	4	4	.	5	:	6	6	6	6	:	7	7	7

1	Source format
UNLK	DDR_UNLOCK
ANA	DDR_ANALOG
PCM	DDR_PCM
AC3	DDR_AC3
DTS	DDR_DTS
MPEG	DDR_MPEG
DATA	DDR_DATA
UNKW	DDR_UNKNOWN
NORD	DDR_NOT_READY
NPCM	DDR_NOT_PCM
FS96	DDR_FS96
NODT	DDR_NOT_DETECT
DTSC	DDR_DTSCD
AAC	DDR_AAC
MPCM	DDR_MCHPCM
MCH	DDR_MCH
TRUE	DDR_TRUE
MSTR	DDR_MSTR
DSD	DDR_DSD
PLUS	DDR_DDPLUS
EXPR	DDR_DTSEXP
DTSH	DDR_DTSHD

2	Sampling freq.
3	Sampling freq. for display
???	unknown
008	8kHz
011	11kHz
012	12kHz
016	16kHz
022	22kHz
024	24kHz
032	32kHz
044	44.1kHz
048	48kHz
064	64Hz
088	88.2kHz
096	96kHz
176	176.4kHz
192	192kHz

4	Number of Input channels for Listening mode transition
5	Input channel
0	SW 0ch
1	SW 1ch
2	SW 2ch
6	Number of channels for FL display
4-digit string "10.2" " 5.1" " 1+1"	

7	Number of channels decoded
???	C_FMT_UNKNOWN
10	C_FMT_10
20	C_FMT_20
30	C_FMT_30
21	C_FMT_21
31	C_FMT_31
22	C_FMT_22
32	C_FMT_32
23	C_FMT_23
33	C_FMT_33
24	C_FMT_24
34	C_FMT_34
4H2	C_FMT_42H
5H2	C_FMT_52H
4W2	C_FMT_42W
5W2	C_FMT_52W
4H4	C_FMT_44H
4H3	C_FMT_43H
5H4	C_FMT_54H
5H3	C_FMT_53H
4W4	C_FMT_44W
4W3	C_FMT_43W
5W4	C_FMT_54W
5W3	C_FMT_53W
11	C_FMT_11

# Debug Mode

2	:	8	:	9	9	9	:	10	10	10	10	
		11		11	:	12	:	13	:	14	14	14
												15
												15

- 8 Audio output OK?  
(Decode OK?)
- Decode OK
- Decode NO good

9 Detail of input format

10	Detail of input format for display
ANA	C_SRC_ANA
PCM	C_SRC_PCM
DLB	C_SRC_DD
DEX	C_SRC_DD_EX
DTS	C_SRC_DTS
MTR	C_SRC_DTS_MTR
DSC	C_SRC_DTS_DSC
D96	C_SRC_DTS_96
96M	C_SRC_DTS_96M
AAC	C_SRC_AAC
MCH	C_SRC_MCH
DSP	C_SRC_DSP
MPCM	C_SRC_MCHPCM
DSD	C_SRC_DSD
TRUE	C_SRC_TRUE
TREX	C_SRC_TRUE_EX
MSTR	C_SRC_MSTR
PLUS	C_SRC_DDPLUS
PLEX	C_SRC_DDPLUS_EX
EXP	C_SRC_DTSEXP
DTSH	C_SRC_DTSHD
DSUR	C_SRC_DD_SUR
DPSR	C_SRC_DDPLUS_SUR
TRSR	C_SRC_TRUE_SUR

- 11 Dialog nome
- Value of dialog norm ( 0 ~ 31 )

- 12 DIR condition
- LOCK
- UNLOCK

- 13 DIR busy or free
- F Free
- B Busy

- 14 Emphasis
- ON ON
- OFF OFF

- 15 HDDVD/BLUE(DDPLUS only)
- BD Bluray
- HD HDDVD

# About Cooling Fan

## Cooling Fan

E.g. (TX-RZ800)

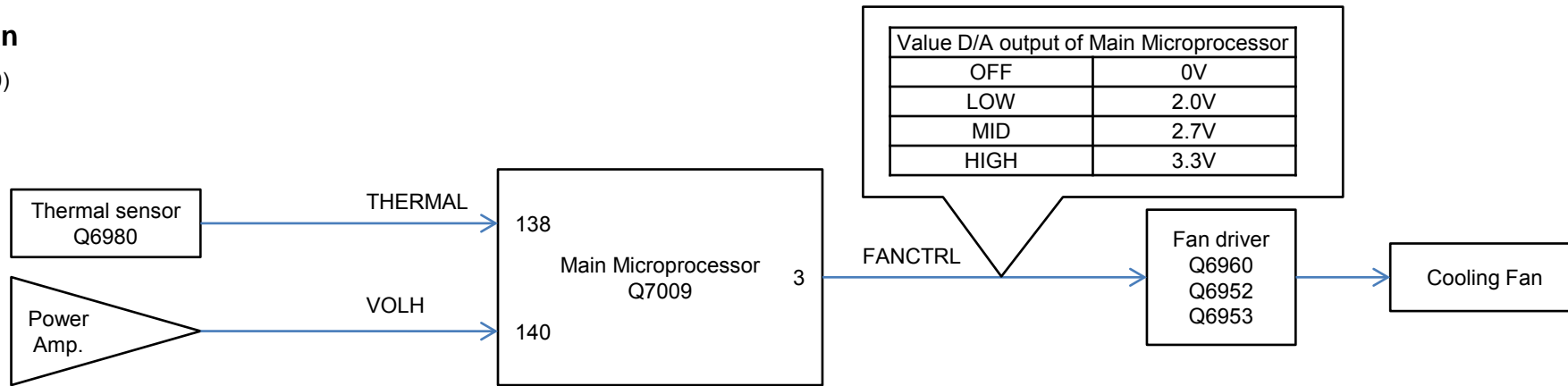

## Condition to operate

		VOLH			
		OFF or Headphone	LOW	MID	HIGH
THERMAL	OFF	STOP	STOP	STOP	STOP
	LOW	LOW	LOW	LOW	LOW
	MID	LOW	MID	MID	MID
	HIGH	HIGH	HIGH	HIGH	HIGH

## THERMAL (Temperature of thermal sensor)

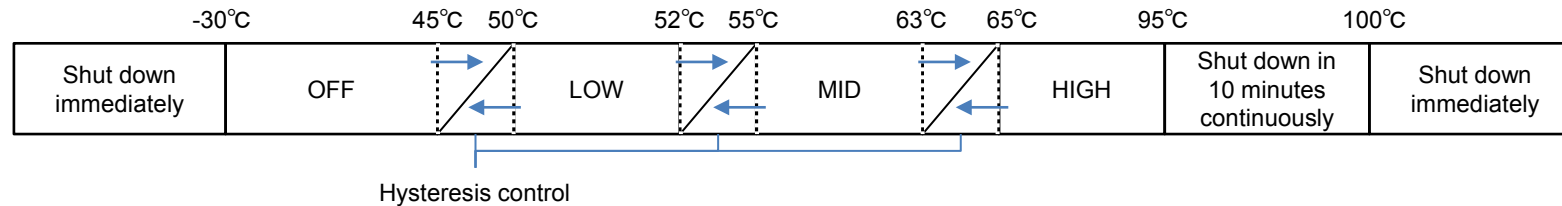

## VOLH (Voltage of VOLH port)

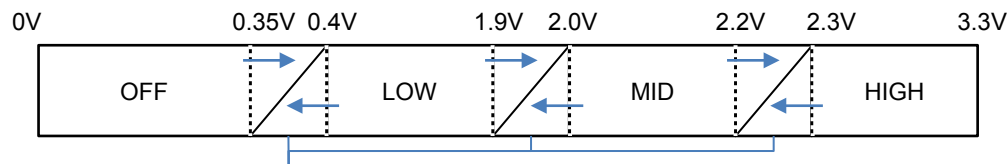

# Service Information Mode

## Displaying Service information

This service information display system is helpful in analyze the status when the unit goes into Protect mode and is powered off. Pay attention that the status will change if a button is pushed.

## How to enter to service information mode.

**Step1** : Set the volume level as 30.

**Step2** : [DISPLAY] + [ON/STANDBY] x 2



**Step3** : [SETUP] or [HOME]

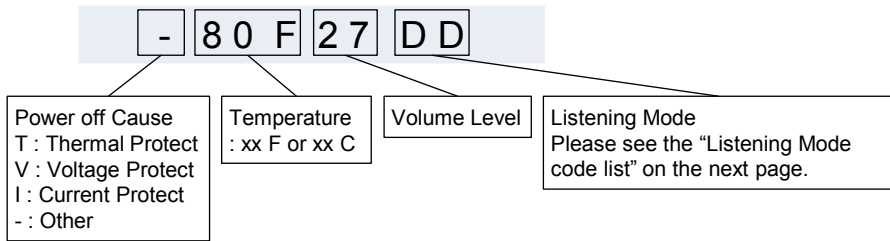

**Step4** : [SETUP] or [HOME]

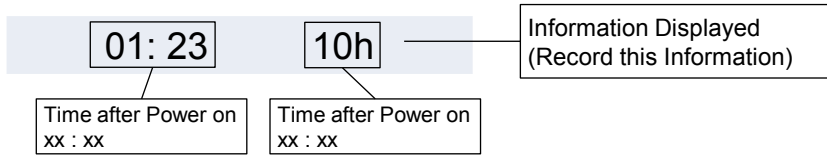

## How to exit the service information mode.

[ON/STANDBY]

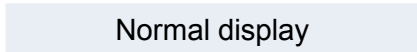

[RETURN] (to initialize the data in the service information.)

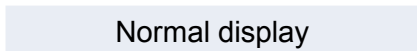
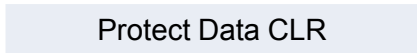

# Service Information Mode

# Appendix

## Listening Mode Code List

00	NORMAL_LMD_BEGIN	20	SURR_LMD_BEGIN	50	THX_MUSIC_LMD_BEGIN	90	THX_CINEMA_LMD_BEGIN	D0	AUDYSSEY_LMD_BEGIN
01	LAST	21	SURR_20_PLII_MOVIE	51	THX_20_PLII_MUSIC	91	THX_20_PLII_MOVIE	D1	AUDYSSEY_20_PLII_MUSIC
02	PURE	22	SURR_20_PLII_MUSIC	52	THX_20_PLIIX_MUSIC	92	THX_20_PLIIX_MOVIE	D2	AUDYSSEY_20_PLIIX_MUSIC
03	DIRECT	23	SURR_20_PLII_GAME	53	THX_20_PLIIZ_MUSIC	93	THX_20_PLIIZ_CINEMA	D3	AUDYSSEY_20_NEO6_MUSIC
04	STEREO	24	SURR_20_PLIIX_MOVIE	54	THX_20_NEO6_MUSIC	94	THX_20_NEO6_MOVIE	D4	AUDYSSEY_20_NEURAL_CINEMA
05	MONO	25	SURR_20_PLIIX_MUSIC	55	THX_20_NEURAL_MUSIC	95	THX_20_NEURAL_CINEMA	D5	AUDYSSEY_20_NEURAL_MUSIC
06	ORCHESTRA	26	SURR_20_PLIIX_GAME	56	THX_51_OFF_MUSIC	96	THX_51_OFF_CINEMA	D6	AUDYSSEY_20_PLII_MOVIE
07	UNPLUGGED	27	SURR_20_PLIIZ	57	THX_51_MTR_MUSIC	97	THX_51_MTR_CINEMA	D7	AUDYSSEY_20_PLIIX_MOVIE
08	STUDIOMIX	28	SURR_20_NEO6_MOVIE	58	THX_51_DSC_MUSIC	98	THX_51_DSC_CINEMA	D8	AUDYSSEY_20_NEO6_MOVIE
09	TVLOGIC	29	SURR_20_NEO6_MUSIC	5A	THX_51_PLIIX_MUSIC	99	THX_51_NEO6_CINEMA	D9	AUDYSSEY_20_PLII_GAME
0A	ALLCHST	2A	SURR_20_NEURAL_MUSIC	5B	THX_51_PLIIZ_MUSIC	9A	THX_51_PLIIX_MOVIE	DA	AUDYSSEY_20_PLIIX_GAME
0B	FULLMONO	2B	SURR_20_NEURAL_CINEMA	5C	THX_51_NEO6_MUSIC	9B	THX_51_PLIIZ_CINEMA	DB	AUDYSSEY_51_OFF
0C	TD	2C	SURR_51_OFF	5D	THX_51_NEURAL_MUSIC	9C	THX_51_NEURAL_CINEMA	DC	AUDYSSEY_51_PLIIX_MUSIC
0D	RPG	2D	SURR_51_MTR	5E	THX_20_NEOX_MUSIC	9D	THX_51_EX	DD	AUDYSSEY_51_PLIIX_MOVIE
0E	ACTION	2E	SURR_51_DSC	5F	THX_51_NEOX_MUSIC	9E	THX_20_NEOX_CINEMA	DE	AUDYSSEY_51_NEO6
0F	ROCKBAND	2F	SURR_51_NEO6	60	THX_20_DOLBY_SURR_MUSIC	9F	THX_51_NEOX_CINEMA	DF	AUDYSSEY_51_NEURAL_CINEMA
10	SPORTS	30	SURR_51_EX	61	THX_51_DOLBY_SURR_MUSIC	A0	THX_20_DOLBY_SURR_CINEMA	E0	// AUDYSSEY_51_NEURAL_MUSIC
11	WHOLEHOUSE	31	SURR_51_PLIIX_MOVIE	62	THX_MUSIC_LMD_END	A1	THX_51_DOLBY_SURR_CINEMA	E1	AUDYSSEY_51_EX
12	RPG_GENRE	32	SURR_51_PLIIX_MUSIC			A2	THX_CINEMA_LMD_END	E2	AUDYSSEY_LMD_END
13	ACTION_GENRE	33	SURR_51_PLIIZ	70	THX_GAME_LMD_BEGIN	B0	THX_U2GAME_LMD_BEGIN	F0	SPECIAL_LMD_BEGIN
14	ROCKBAND_GENRE	34	SURR_51_NEURAL_CINEMA	71	THX_20_PLII_GAME	B1	THX_20_PLII_SLCT2_GAME	F1	TESTTONE
15	SPORTS_GENRE	35	SURR_20_NEOX_CINEMA	72	THX_20_PLIIX_GAME	B2	THX_20_PLIIZ_SLCT2_GAME	F2	TESTTHR
12	NORMAL_LMD_END	36	SURR_20_NEOX_MUSIC	73	THX_20_PLIIZ_GAME	B3	THX_51_SLCT2_GAM	F3	TESTAUTO
		37	SURR_20_NEOX_GAME	74	THX_20_NEURAL_GAMES	B4	THX_51_PLIIZ_SLCT2_GAME	F4	ASC
		38	SURR_51_NEOX_CINEMA	75	THX_51_OFF_GAMES	B5	THX_U2GAME_LMD_END	F5	FLASH
		39	SURR_51_NEOX_MUSIC	76	THX_51_MTR_GAMES	B6	THX_U2MUSIC_LMD_BEGIN	F6	DEBUGMODE
		40	SURR_51_NEOX_GAME	77	THX_51_DSC_GAMES	B7	THX_51_SLCT2_MUS	F7	FLASH2
		41	SURR_20_DOLBY_SURR	78	THX_51_PLIIX_GAME	B8	THX_51_PLIIZ_SLCT2_MUSIC	F8	FLASH3
		42	SURR_51_DOLBY_SURR	79	THX_51_PLIIZ_GAMES	B9	THX_U2MUSIC_LMD_END	F9	FLASH4
		43	SURR_LMD_END	7A	THX_51_NEO6_GAMES	BA	THX_U2CINEMA_LMD_BEGIN	FA	FLASH_CHECK
				7B	THX_51_NEURAL_GAMES	BB	THX_51_SLCT2_CIN	FB	SPECIAL_LMD_END
		48	DTSSS_LMD_BEGIN	7C	THX_20_NEOX_GAMES	BC	THX_51_PLIIZ_SLCT2_CINEMA		
		49	DTSSS_20_NEO6_MUSIC	7D	THX_51_NEOX_GAMES	BD	THX_U2CINEMA_LMD_END		
		4A	DTSSS_20_NEO6_CINEMA	7E	THX_20_DOLBY_SURR_GAME				
		4B	DTSSS_51	7F	THX_51_DOLBY_SURR_GAME				
		4C	DTSSS_LMD_END	80	THX_GAME_LMD_END				



**DHC-60.7(B)MDD****<Note>**

Parts marked by "NSP" are generally unavailable because they are not in our Master Spare Parts List.

**NOTE : THE COMPONENTS IDENTIFIED BY THE MARK ! ARE CRITICAL FOR RISK OF FIRE AND ELECTRIC SHOCK. REPLACE ONLY WITH PART**

**<Notes>****(B) : Black color model****<MDD> : 120V****USA model**

: NSP

**DHC-60.7(B)MDD****EXPLODED VIEW PARTS LIST**

REF. NO.	PART NAME	DESCRIPTION	Q'TY	PART NO. (SN)	REMARKS
<b>[CHASSIS SCREW]</b>					
A109	BOTTOM LEG		4	27175452A	
A111	CUSHION	(LEG)	4	28141735	
A221	LABEL	(PT)INTEGRA	1	29391420	
A251	REAR PANEL	DHC607DD	1	27124687	<b>N</b>
A257	PLATE	(BALANCE)	1	27262915	
A301A	LABEL	(E-CON)	{ 1 }	29364978	
A375	LABEL	(HD-BASET)	1	29392532A	
<b>[CABINET]</b>					
A601	FRONT BRACKET	(B)50.6	1	27111623B	
A605	KNOB	(CUR)B	1	28326682A	
A607	P RIVET	P-3055B-8L	2	880048	
A615	KNOB	(STANDBY)	1	28325756A	
A651	FRONT PANEL	DHC607(B)DD	1	27213795A	<b>N</b>
A653	BADGE		1	28135278	
A659	FACET		3	28198905	
A663	DECORATIVE FRAME		1	28159049B	
A667	CLEAR PLATE		1	28192233	
A669	BACK PLATE		1	28133430	
A699	KNOB	(VOL)AS	1	28326231D	
A701	COVER	(B)40.5 (Bent)	1	28210120	
A701	COVER	(B)40.5 (Not Bent)	1	28210120Z	
A731	LABEL	(CAUTION)	1	29392531	
<b>[TRANS COIL]</b>					
T902	POWER TRANSFORMER	NPT-1655D	1	2302129A	<b>N, !</b>
T903	POWER TRANSFORMER	NPT-1558D	1	2301911B	<b>!</b>
<b>[SW TRM]</b>					
P2101	FLEXIBLE FLAT CABLE	NCFC5-401012	1	2045401012UL	
P212	FLEXIBLE FLAT CABLE	NCFC5-170512	1	2045170512	
P2203	FLEXIBLE FLAT CABLE	NCFC5-151012	1	2045151012	
P2204	FLEXIBLE FLAT CABLE	NCFC7-070512	1	2047070512	<b>N</b>
P4605	FLEXIBLE FLAT CABLE	NCFC7-091012	1	2047091012	
P7001	FLEXIBLE FLAT CABLE	NCFC5-131012	1	2045131012	
P7002	FLEXIBLE FLAT CABLE	NCFC5-274022	1	2045274022	<b>N</b>
P8691	CORD ASSEMBLY	HDMI 0.65M	1	2010502A	
P900	AC INLET	R301X2PSn	1	25053358	<b>!</b>
<b>[MECHANISM]</b>					
A1409	INSTRUCTION SHEET	15AVR_DTSX_U12	1	29355946	
<b>[TUNER UNIT]</b>					
<b>U001</b>	<b>PARENT PC BOARD AS</b>	<b>BAASP-1797-1D * (Parent)</b>	<b>1</b>	<b>1B304597-1D</b>	<b>MDD</b>
	BAASP-1797 AUDIO PC BOARD AS	BAASP-1797-1D (Child)	1	1B3045797-1D-C	
	BAVD-1798 VIDEO PC BOARD AS	BAVD-1798-1D (Child)	1	1B3045798-1D-C	
<b>U002</b>	<b>PARENT PC BOARD AS</b>	<b>BADG-1800-1D * (Parent)</b>	<b>1</b>	<b>1B304500-1D</b>	<b>MDD</b>
	BADG-1800 DIGITAL(DIR/ DAC) PC BOARD AS	BADG-1800-1D (Child)	1	1B3045800-1D-C	
<b>U003</b>	<b>PARENT PC BOARD AS</b>	<b>BADIS-1816-1C * (Parent)</b>	<b>1</b>	<b>1B304516-1C</b>	<b>MDD</b>
	BADIS-1816 DISPLAY PC BOARD AS	BADIS-1816-1C (Child)	1	1B3045816-1C-C	
	BASW-1817 SWITCH/ LED PC BOARD AS	BASW-1817-1C (Child)	1	1B3045817-1C-C	
	BASW-1818 VOLUME PC BOARD AS	BASW-1818-1C (Child)	1	1B3045818-1C-C	
	BAETC-1819 PHONE JACK PC BOARD AS	BAETC-1819-1C (Child)	1	1B3045819-1C-C	

BARF-1821 TUNER PC BOARD AS	BARF-1821-1C (Child)	1	1B3045821-1C-C	
<b>U004 PARENT PC BOARD AS</b>	<b>BAPRC-1802-1E * (Parent)</b>	<b>1</b>	<b>1B304502-1E</b>	<b>MDD</b>
BAPRC-1802 PROCESSOR PC BOARD AS	BAPRC-1802-1E (Child)	1	1B3045802-1E-C	
<b>U005 PARENT PC BOARD AS</b>	<b>BATRM-1804-1A * (Parent)</b>	<b>1</b>	<b>1B304504-1A</b>	<b>MDD</b>
BATRM-1804 TERMINAL(BALANCE) PC BOARD AS	BATRM-1804-1A (Child)	1	1B3045804-1A	
<b>U006 PARENT PC BOARD AS</b>	<b>BAAF-1806-1A * (Parent)</b>	<b>1</b>	<b>1B304506-1A</b>	<b>MDD</b>
BAAF-1806 TERMINAL(BALANCE OUT SW) PC BOARD AS	BAAF-1806-1A (Child)	1	1B3045806-1A-C	
BAPS-1807 POWER SUPPLY(PRI) PC BOARD AS	BAPS-1807-1A (Child)	1	1B3045807-1A-C	
BAETC-1808 CONNENCTOR(VD-ASP) PC BOARD AS	BAETC-1808-1A (Child)	1	1B3045808-1A-C	
<b>U008 PARENT PC BOARD AS</b>	<b>BAHDM-1822-1A * (Parent)</b>	<b>1</b>	<b>1B304522-1A</b>	<b>MDD</b>
BAHDM-182 HD BASE-T PC BOARD AS	BAHDM-1822-1A (Child)	1	1B3045822-1A-C	
BAHDM-182 TERMINAL(FRONT HDMI) PC BOARD AS	BAHDM-1823-1A (Child)	1	1B3045823-1A-C	

**DHC-60.7(B)MDD****PACKING PROCEDURES PARTS LIST**

REF. NO.	PART NAME	DESCRIPTION	Q'TY	PART NO. (SN)	REMARKS
<b>[PACKING]</b>					
A802	PAD	(AS)507	1	29092726A	N
A802A	PAD	(F)507	{ 1}	29092727A	N
A802B	PAD	(R)507	{ 1}	29092728A	N
A803	SHEET	T1.015 x 1300 x 800	1	29096134	
A805	TAPE	(SEROHAN)NITTO NO.29	1	29110149	
A831	CARTON	DHC607	1	29055564	N
A841	SHEET	(ACC)	1	29096104	
A851	POLYPROPYLENE TAPE	W50 SBT-70	1	29110200	
A951A	UPC LABEL	DHC607(B)MDD	{ 1}	29392873	N
<b>[ACCESSARY]</b>					
A1001	POLY BAG	w250xd350	1	29100250A	
A1003	TAPE	(SEROHAN)NITTO NO.29	1	29110149	
A1008	WARRANTY CARD	(INTEGRA)	1	29365157	
A1301	INSTRUCTION MANUAL	SAFETY_INT_En	1	29401786	
A1357	INSTRUCTION MANUAL	BAS_En(DHC607)	1	29402054	N
A1501	BATTERY	R6/AA(UM-3)	2	3010194	
A1501 or	BATTERY	R6/AA(UM-3)	( 2)	3010054	
A1503	MIC	MIC-5011	1	245047	
A1505	ANTENNA COIL	AM LOOP-ANTENNA	1	232207	
A1507	FM ANT AS	Type W	1	292191	
A1511	REMOTE CONTROL TRANSMITTER	RC-901M	1	24140901	
P2001	POWER SUPPLY CORD	AS-UC-2	1	253352ATES	!
P2005	CORD ASSEMBLY	HDMI 0.35M	1	2010512	

DHC-60.7(B)MDD

## PC BOARD PARTS LIST

U001

BAASP-1797-1D

: NSP

CIRCUIT NO	PART NAME	DESCRIPTION	Q'TY	PART NO. (SN)	REMARKS
<b>[SEMI CONDUCTOR]</b>					
D2901	DIODE	D5SBA60	1	22380070	
D2901A	HEAT SINK	RAD-083	1	27160271	
D2901B	SCREW	3P+6FN(3BC)	1	82143006GR	
D2902	DIODE	RB050M-30GTR	1	22380373R2	
D2903	CHIP TYPE DIODE	DA2J10100	1	223303R2	
D2903 or	CHIP TYPE DIODE	1SS352	(1)	223234R2	
D2904	CHIP TYPE DIODE	DA2J10100	1	223303R2	
D2904 or	CHIP TYPE DIODE	1SS352	(1)	223234R2	
D2905	ZENER DIODE	DZ2J056M0L	1	224760560R2	
D2905 or	ZENER DIODE	UDZS5.6B	(1)	224550560R2	
D2906	CHIP TYPE DIODE	DA2J10100	1	223303R2	
D2906 or	CHIP TYPE DIODE	1SS352	(1)	223234R2	
D2907	ZENER DIODE	DZ2J056M0L	1	224760560R2	
D2907 or	ZENER DIODE	UDZS5.6B	(1)	224550560R2	
D2908	CHIP TYPE DIODE	DA2J10100	1	223303R2	
D2908 or	CHIP TYPE DIODE	1SS352	(1)	223234R2	
D2912	DIODE	RB050M-30GTR	1	22380373R2	
D2951	CHIP TYPE DIODE	S1NB60-4062	1	22380318R2	
D2953	DIODE	RL1N4003	1	22380260T	
D4231	ZENER DIODE	DZ2J075M0L	1	224760750R2	
D4231 or	ZENER DIODE	UDZS7.5B	(1)	224550750R2	
D4232	ZENER DIODE	DZ2J075M0L	1	224760750R2	
D4232 or	ZENER DIODE	UDZS7.5B	(1)	224550750R2	
D4331	ZENER DIODE	DZ2J075M0L	1	224760750R2	
D4331 or	ZENER DIODE	UDZS7.5B	(1)	224550750R2	
D4332	ZENER DIODE	DZ2J075M0L	1	224760750R2	
D4332 or	ZENER DIODE	UDZS7.5B	(1)	224550750R2	
D4693	CHIP TYPE DIODE	DA2J10100	1	223303R2	
D4693 or	CHIP TYPE DIODE	1SS352	(1)	223234R2	
D4700	CHIP TYPE DIODE	DA2J10100	1	223303R2	
D4700 or	CHIP TYPE DIODE	1SS352	(1)	223234R2	
D4701	CHIP TYPE DIODE	DA2J10100	1	223303R2	
D4701 or	CHIP TYPE DIODE	1SS352	(1)	223234R2	
D4702	CHIP TYPE DIODE	DA2J10100	1	223303R2	
D4702 or	CHIP TYPE DIODE	1SS352	(1)	223234R2	
D4901	ZENER DIODE	DZ2J075M0L	1	224760750R2	
D4901 or	ZENER DIODE	UDZS7.5B	(1)	224550750R2	
D4902	ZENER DIODE	DZ2J075M0L	1	224760750R2	
D4902 or	ZENER DIODE	UDZS7.5B	(1)	224550750R2	
D4909	ZENER DIODE	DZ2J075M0L	1	224760750R2	
D4909 or	ZENER DIODE	UDZS7.5B	(1)	224550750R2	
D4910	ZENER DIODE	DZ2J075M0L	1	224760750R2	
D4910 or	ZENER DIODE	UDZS7.5B	(1)	224550750R2	
Q2001	HYBRID IC	NJW1328	1	22242691R3	
Q2511	TRANSISTOR	2SC2712-GR	1	2213145R2	
Q2512	TRANSISTOR	2SA1162-GR	1	2214375R2	
Q2513	TRANSISTOR	2SA1162-GR	1	2214375R2	
Q2514	TRANSISTOR	KTA1040D	1	2218210R2	
Q2521	TRANSISTOR	2SC2712-GR	1	2213145R2	
Q2522	TRANSISTOR	2SA1162-GR	1	2214375R2	
Q2523	TRANSISTOR	2SA1162-GR	1	2214375R2	
Q2524	TRANSISTOR	KTA1661-Y	1	2217864R2	
Q2531	TRANSISTOR	2SC2712-GR	1	2213145R2	
Q2532	TRANSISTOR	2SA1162-GR	1	2214375R2	
Q2533	TRANSISTOR	2SA1162-GR	1	2214375R2	

Q2534	TRANSISTOR	KTA1661-Y	1	2217864R2
Q2701	TRANSISTOR	2SA1162-GR	1	2214375R2
Q2702	PHOTO COUPLER	TLP785(BL-TP6_F(C	1	24120173R2
Q2703	PHOTO COUPLER	TLP785(BL-TP6_F(C	1	24120173R2
Q2704	PHOTO COUPLER	TLP785(BL-TP6_F(C	1	24120173R2
Q2705	PHOTO COUPLER	TLP785(BL-TP6_F(C	1	24120173R2
Q2800	HYBRID IC	ICL3221ECVZ	1	22242268R2
Q2800 or	HYBRID IC	TRS3221ECPWR	( 1)	22242805R2
Q2951	HYBRID IC	78M05(NJM78M05FA)	1	222780055JRC
Q2951A	HEAT SINK	ME151025402170	1	27160692
Q2951B	SCREW	3P+6FN(3BC)	1	82143006GR
Q2952	HYBRID IC	78M05(NJM78M05FA)	1	222780055JRC
Q2952A	HEAT-SINK	HEAT-SINK	1	27160179
Q2952B	SCREW	3P+6FN(3BC)	1	82143006GR
Q4001	HYBRID IC	NJW1298FU1	1	22242925R3
Q4101	HYBRID IC	NJM4580CG	1	22242922R2
Q4121	HYBRID IC	NJM4580CG	1	22242922R2
Q4141	HYBRID IC	NJM4580CG	1	22242922R2
Q4142	HYBRID IC	NJM4580CG	1	22242922R2
Q4161	HYBRID IC	NJM4580CG	1	22242922R2
Q4201	HYBRID IC	NJW1194	1	22242893R2
Q4241	TRANSISTOR	RTAN430C-T112-1	1	2217780R2
Q4242	TRANSISTOR	RTAN430C-T112-1	1	2217780R2
Q4301	HYBRID IC	NJW1194	1	22242893R2
Q4341	TRANSISTOR	RTAN430C-T112-1	1	2217780R2
Q4342	TRANSISTOR	RTAN430C-T112-1	1	2217780R2
Q4600	TRANSISTOR	RTAN430C-T112-1	1	2217780R2
Q4601	TRANSISTOR	RTAN430C-T112-1	1	2217780R2
Q4602	TRANSISTOR	RTAN430C-T112-1	1	2217780R2
Q4603	TRANSISTOR	RTAN430C-T112-1	1	2217780R2
Q4604	TRANSISTOR	RTAN430C-T112-1	1	2217780R2
Q4605	TRANSISTOR	RTAN430C-T112-1	1	2217780R2
Q4606	TRANSISTOR	RTAN430C-T112-1	1	2217780R2
Q4607	TRANSISTOR	RTAN430C-T112-1	1	2217780R2
Q4608	TRANSISTOR	RTAN430C-T112-1	1	2217780R2
Q4610	TRANSISTOR	RTAN430C-T112-1	1	2217780R2
Q4611	TRANSISTOR	RTAN430C-T112-1	1	2217780R2
Q4612	TRANSISTOR	RTAN430C-T112-1	1	2217780R2
Q4613	TRANSISTOR	RTAN430C-T112-1	1	2217780R2
Q4614	TRANSISTOR	RTAN430C-T112-1	1	2217780R2
Q4615	TRANSISTOR	RTAN430C-T112-1	1	2217780R2
Q4616	TRANSISTOR	RTAN430C-T112-1	1	2217780R2
Q4617	TRANSISTOR	RTAN430C-T112-1	1	2217780R2
Q4618	TRANSISTOR	RTAN430C-T112-1	1	2217780R2
Q4620	TRANSISTOR	RTAN430C-T112-1	1	2217780R2
Q4621	TRANSISTOR	RTAN430C-T112-1	1	2217780R2
Q4622	TRANSISTOR	RTAN430C-T112-1	1	2217780R2
Q4630	TRANSISTOR	RTAN430C-T112-1	1	2217780R2
Q4631	TRANSISTOR	RTAN430C-T112-1	1	2217780R2
Q4632	TRANSISTOR	RTAN430C-T112-1	1	2217780R2
Q4691	TRANSISTOR	KRA102S	1	2216220R2
Q4691 or	TRANSISTOR	DTA124EKA	( 1)	2216240R2
Q4700	TRANSISTOR	KRC105S	1	2217290R2
Q4700 or	TRANSISTOR	RN1405	( 1)	2214500R2
Q4700 or	TRANSISTOR	DTC123JKA	( 1)	2216690R2
Q4701	TRANSISTOR	KRC105S	1	2217290R2
Q4701 or	TRANSISTOR	RN1405	( 1)	2214500R2
Q4701 or	TRANSISTOR	DTC123JKA	( 1)	2216690R2
Q4702	TRANSISTOR	KRC105S	1	2217290R2
Q4702 or	TRANSISTOR	RN1405	( 1)	2214500R2
Q4702 or	TRANSISTOR	DTC123JKA	( 1)	2216690R2
Q4901	TRANSISTOR	2SA1488-Y	1	2203394

Q4902	TRANSISTOR	2SC3851-Y	1	2203384	
Q4903	TRANSISTOR	2SC2712-GR	1	2213145R2	
Q4904	TRANSISTOR	2SA1162-GR	1	2214375R2	
<b>[TRANS COIL]</b>					
L2001	CHOKE COIL	LBC2518T4R7M	1	231364M047R2	
L2800	CHOKE COIL	LBC2518T470M	1	231364M470R2	
<b>[CAPACITOR]</b>					
C2001	JAMICON TYPE ELECTROLYTIC CAPACITOR	CE04W6.3V-470M	1	398524717T	
C2002	CHIP TYPE CERAMIC CAPACITOR	CK725B1C-104K1	1	332121045R1	
C2003	CHIP TYPE CERAMIC CAPACITOR	CK725B1C-104K1	1	332121045R1	
C2004	CHIP TYPE CERAMIC CAPACITOR	CK725B1C-104K1	1	332121045R1	
C2005	CHIP TYPE CERAMIC CAPACITOR	CK725B1C-104K1	1	332121045R1	
C2006	CHIP TYPE CERAMIC CAPACITOR	CK725B1C-104K1	1	332121045R1	
C2007	CHIP TYPE CERAMIC CAPACITOR	CK725B1C-104K1	1	332121045R1	
C2008	CHIP TYPE CERAMIC CAPACITOR	CK725B1C-104K1	1	332121045R1	
C2009	JAMICON TYPE ELECTROLYTIC CAPACITOR	CE04W6.3V-470M	1	398524717T	
C2010	JAMICON TYPE ELECTROLYTIC CAPACITOR	CE04W6.3V-470M	1	398524717T	
C2011	JAMICON TYPE ELECTROLYTIC CAPACITOR	CE04W16V-100M	1	398541017T	
C2012	JAMICON TYPE ELECTROLYTIC CAPACITOR	CE04W6.3V-470M	1	398524717T	
C2013	CHIP TYPE CERAMIC CAPACITOR	CK725B1C-104K1	1	332121045R1	
C2015	CHIP TYPE CERAMIC CAPACITOR	CK725B1C-104K1	1	332121045R1	
C2102	JAMICON TYPE ELECTROLYTIC CAPACITOR	CE04W50V-2.2M	1	398580227T	
C2104	JAMICON TYPE ELECTROLYTIC CAPACITOR	CE04W50V-2.2M	1	398580227T	
C2106	JAMICON TYPE ELECTROLYTIC CAPACITOR	CE04W50V-2.2M	1	398580227T	
C2107	CHIP TYPE CARBON RESISTOR	RN72K1J-000JE	1	435030004R1	
C2108	CHIP TYPE CARBON RESISTOR	RN72K1J-000JE	1	435030004R1	
C2109	CHIP TYPE CERAMIC CAPACITOR	CC725CH1H-151J1	1	342101514R1	
C2110	CHIP TYPE CARBON RESISTOR	RN72K1J-000JE	1	435030004R1	
C2112	JAMICON TYPE ELECTROLYTIC CAPACITOR	CE04W50V-2.2M	1	398580227T	
C2114	JAMICON TYPE ELECTROLYTIC CAPACITOR	CE04W50V-2.2M	1	398580227T	
C2116	JAMICON TYPE ELECTROLYTIC CAPACITOR	CE04W50V-2.2M	1	398580227T	
C2118	JAMICON TYPE ELECTROLYTIC CAPACITOR	CE04W50V-2.2M	1	398580227T	
C2120	JAMICON TYPE ELECTROLYTIC CAPACITOR	CE04W50V-2.2M	1	398580227T	
C2122	JAMICON TYPE ELECTROLYTIC CAPACITOR	CE04W50V-2.2M	1	398580227T	
C2126	JAMICON TYPE ELECTROLYTIC CAPACITOR	CE04W6.3V-470M	1	398524717T	
C2127	JAMICON TYPE ELECTROLYTIC CAPACITOR	CE04W6.3V-470M	1	398524717T	
C2128	JAMICON TYPE ELECTROLYTIC CAPACITOR	CE04W6.3V-470M	1	398524717T	
C2129	JAMICON TYPE ELECTROLYTIC CAPACITOR	CE04W6.3V-470M	1	398524717T	
C2800	CHIP TYPE CERAMIC CAPACITOR	CK732B16V-106K	1	332071065R2	
C2801	CHIP TYPE CERAMIC CAPACITOR	CK725B1C-104K1	1	332121045R1	
C2802	CHIP TYPE CERAMIC CAPACITOR	CK725B1C-104K1	1	332121045R1	
C2803	CHIP TYPE CERAMIC CAPACITOR	CK725B1C-104K1	1	332121045R1	
C2804	CHIP TYPE CERAMIC CAPACITOR	CK725B1C-104K1	1	332121045R1	
C2805	CHIP TYPE CERAMIC CAPACITOR	CK725B1C-104K1	1	332121045R1	
C2808	CHIP TYPE CERAMIC CAPACITOR	CK725B1H-102K1	1	332101025R1	
C2901	TF TYPE PLASTIC FILM CAPACITOR	ECQ-V50V-334J	1	374723344T	
C2901 or	FILM C	C281H334J20A21A	(1)	376823344T	
C2902	ELECTROLYTIC CAPACITOR	CE04W25V-10000M(TK)	1	3500240	N
C2903	UTSP TYPE ELECTROLYTIC CAPACITOR	CE04W50V-10M(UTSP)	1	397581007AT	
C2951	JAMICON TYPE ELECTROLYTIC CAPACITOR	CE04W25V-4700M	1	398554727S	
C2952	TF TYPE PLASTIC FILM CAPACITOR	ECQ-V50V-334J	1	374723344T	
C2952 or	FILM C	C281H334J20A21A	(1)	376823344T	
C2953	TF TYPE PLASTIC FILM CAPACITOR	ECQ-V50V-334J	1	374723344T	
C2953 or	FILM C	C281H334J20A21A	(1)	376823344T	
C2954	VR TYPE ELECTROLYTIC CAPACITOR	CE04W16V-100M(VR)	1	394641017T	
C2955	VR TYPE ELECTROLYTIC CAPACITOR	CE04W16V-100M(VR)	1	394641017T	
C2957	CHIP TYPE CERAMIC CAPACITOR	CK725B1C-104K1	1	332121045R1	
C4000	CHIP TYPE CERAMIC CAPACITOR	CC725CH1H-221J1	1	342102214R1	
C4001	CHIP TYPE CERAMIC CAPACITOR	CC725CH1H-221J1	1	342102214R1	
C4002	CHIP TYPE CERAMIC CAPACITOR	CC725CH1H-221J1	1	342102214R1	
C4003	CHIP TYPE CERAMIC CAPACITOR	CC725CH1H-221J1	1	342102214R1	
C4004	CHIP TYPE CERAMIC CAPACITOR	CC725CH1H-221J1	1	342102214R1	

C4005	CHIP TYPE CERAMIC CAPACITOR	CC725CH1H-221J1	1	342102214R1	
C4006	CHIP TYPE CERAMIC CAPACITOR	CC725CH1H-221J1	1	342102214R1	
C4007	CHIP TYPE CERAMIC CAPACITOR	CC725CH1H-221J1	1	342102214R1	
C4008	CHIP TYPE CERAMIC CAPACITOR	CC725CH1H-221J1	1	342102214R1	
C4009	CHIP TYPE CERAMIC CAPACITOR	CC725CH1H-221J1	1	342102214R1	
C4012	UPZ TYPE PLASTIC FILM CAPACITOR	2AUPZTF221JE	1	376332214T	
C4013	UPZ TYPE PLASTIC FILM CAPACITOR	2AUPZTF221JE	1	376332214T	
C4014	CHIP TYPE CERAMIC CAPACITOR	CC725CH1H-221J1	1	342102214R1	
C4015	CHIP TYPE CERAMIC CAPACITOR	CC725CH1H-221J1	1	342102214R1	
C4016	CHIP TYPE CERAMIC CAPACITOR	CC725CH1H-221J1	1	342102214R1	
C4017	CHIP TYPE CERAMIC CAPACITOR	CC725CH1H-221J1	1	342102214R1	
C4050	UTSP TYPE ELECTROLYTIC CAPACITOR	CE04W25V-47M(UTSP)	1	397554707AT	
C4051	UTSP TYPE ELECTROLYTIC CAPACITOR	CE04W25V-47M(UTSP)	1	397554707AT	
C4052	UTSP TYPE ELECTROLYTIC CAPACITOR	CE04W25V-47M(UTSP)	1	397554707AT	
C4053	UTSP TYPE ELECTROLYTIC CAPACITOR	CE04W10V-100M(UTSP)	1	397531017AT	
C4054	UTSP TYPE ELECTROLYTIC CAPACITOR	CE04W10V-100M(UTSP)	1	397531017AT	
C4055	UTSP TYPE ELECTROLYTIC CAPACITOR	CE04W10V-100M(UTSP)	1	397531017AT	
C4056	UTSP TYPE ELECTROLYTIC CAPACITOR	CE04W10V-100M(UTSP)	1	397531017AT	
C4057	UTSP TYPE ELECTROLYTIC CAPACITOR	CE04W10V-100M(UTSP)	1	397531017AT	
C4058	UTSP TYPE ELECTROLYTIC CAPACITOR	CE04W10V-100M(UTSP)	1	397531017AT	
C4059	UTSP TYPE ELECTROLYTIC CAPACITOR	CE04W10V-220M(UTSP)	1	397532217AT	
C4060	UTSP TYPE ELECTROLYTIC CAPACITOR	CE04W10V-220M(UTSP)	1	397532217AT	
C4061	UTSP TYPE ELECTROLYTIC CAPACITOR	CE04W50V 47M(UTSP)	1	397584707AT	
C4062	UTSP TYPE ELECTROLYTIC CAPACITOR	CE04W50V 47M(UTSP)	1	397584707AT	
C4063	UTSP TYPE ELECTROLYTIC CAPACITOR	CE04W50V 47M(UTSP)	1	397584707AT	
C4064	UTSP TYPE ELECTROLYTIC CAPACITOR	CE04W50V 47M(UTSP)	1	397584707AT	
C4070	CHIP TYPE CERAMIC CAPACITOR	CC725CH1H-102J1	1	342101024R1	
C4105	CHIP TYPE CERAMIC CAPACITOR	CC725CH1H-101J1	1	342101014R1	
C4106	CHIP TYPE CERAMIC CAPACITOR	CC725CH1H-101J1	1	342101014R1	
C4107	UTSP TYPE ELECTROLYTIC CAPACITOR	CE04W50V 47M(UTSP)	1	397584707AT	
C4108	UTSP TYPE ELECTROLYTIC CAPACITOR	CE04W50V 47M(UTSP)	1	397584707AT	
C4121	UTSP TYPE ELECTROLYTIC CAPACITOR	CE04W50V 47M(UTSP)	1	397584707AT	
C4122	UTSP TYPE ELECTROLYTIC CAPACITOR	CE04W50V 47M(UTSP)	1	397584707AT	
C4123	CHIP TYPE CERAMIC CAPACITOR	CC725CH1H-221J1	1	342102214R1	
C4124	CHIP TYPE CERAMIC CAPACITOR	CC725CH1H-221J1	1	342102214R1	
C4125	TF TYPE PLASTIC FILM CAPACITOR	ECQ-V50V-103J	1	374721034T	
C4126	TF TYPE PLASTIC FILM CAPACITOR	ECQ-V50V-103J	1	374721034T	
C4141	UTSP TYPE ELECTROLYTIC CAPACITOR	CE04W50V 47M(UTSP)	1	397584707AT	
C4142	UTSP TYPE ELECTROLYTIC CAPACITOR	CE04W50V-0.1M(UTSP)	1	397581097AT	N
C4143	UTSP TYPE ELECTROLYTIC CAPACITOR	CE04W50V-0.1M(UTSP)	1	397581097AT	N
C4144	TF TYPE PLASTIC FILM CAPACITOR	ECQ-V50V-104J	1	374721044T	
C4144 or	FILM C	C281H104J20A21A	(1)	376821044T	
C4145	UTSP TYPE ELECTROLYTIC CAPACITOR	CE04W50V 47M(UTSP)	1	397584707AT	
C4153	CHIP TYPE CERAMIC CAPACITOR	CC725CH1H-331J1	1	342103314R1	
C4154	CHIP TYPE CERAMIC CAPACITOR	CC725CH1H-331J1	1	342103314R1	
C4155	UTSP TYPE ELECTROLYTIC CAPACITOR	CE04W50V 47M(UTSP)	1	397584707AT	
C4156	UTSP TYPE ELECTROLYTIC CAPACITOR	CE04W50V 47M(UTSP)	1	397584707AT	
C4161	UTSP TYPE ELECTROLYTIC CAPACITOR	CE04W50V 47M(UTSP)	1	397584707AT	
C4162	UTSP TYPE ELECTROLYTIC CAPACITOR	CE04W50V 47M(UTSP)	1	397584707AT	
C4163	CHIP TYPE CERAMIC CAPACITOR	CC725CH1H-102J1	1	342101024R1	
C4164	CHIP TYPE CERAMIC CAPACITOR	CC725CH1H-102J1	1	342101024R1	
C4165	UTSP TYPE ELECTROLYTIC CAPACITOR	CE04W25V-220M(UTSP)	1	397552217T	
C4166	UTSP TYPE ELECTROLYTIC CAPACITOR	CE04W25V-220M(UTSP)	1	397552217T	
C4167	TF TYPE PLASTIC FILM CAPACITOR	ECQ-V50V-123J	1	374721234T	
C4168	TF TYPE PLASTIC FILM CAPACITOR	ECQ-V50V-123J	1	374721234T	
C4169	UMXR TYPE PLASTIC FILM CAPACITOR	1JUMXRTF332JE	1	376593324T	N
C4170	UMXR TYPE PLASTIC FILM CAPACITOR	1JUMXRTF332JE	1	376593324T	N
C4175	UTSP TYPE ELECTROLYTIC CAPACITOR	CE04W50V-10M(UTSP)	1	397581007AT	
C4176	UTSP TYPE ELECTROLYTIC CAPACITOR	CE04W50V-10M(UTSP)	1	397581007AT	
C4177	CHIP TYPE CERAMIC CAPACITOR	CK725B1H-472K1	1	332104725R1	
C4178	CHIP TYPE CERAMIC CAPACITOR	CK725B1H-472K1	1	332104725R1	
C4201	UTSP TYPE ELECTROLYTIC CAPACITOR	CE04W50V 47M(UTSP)	1	397584707AT	



C4202	UTSP TYPE ELECTROLYTIC CAPACITOR	CE04W50V 47M(UTSP)	1	397584707AT
C4203	UTSP TYPE ELECTROLYTIC CAPACITOR	CE04W25V-100M(UTSP)	1	397551017AT
C4204	UTSP TYPE ELECTROLYTIC CAPACITOR	CE04W25V-100M(UTSP)	1	397551017AT
C4205	CHIP TYPE CERAMIC CAPACITOR	CK725B1H-104K1	1	332101045R1
C4206	CHIP TYPE CERAMIC CAPACITOR	CK725B1H-104K1	1	332101045R1
C4207	VR TYPE ELECTROLYTIC CAPACITOR	CE04W50V-4.7M(VR)	1	394680477T
C4208	VR TYPE ELECTROLYTIC CAPACITOR	CE04W50V-4.7M(VR)	1	394680477T
C4209	CHIP TYPE CERAMIC CAPACITOR	CK725B1H-332K1	1	332103325R1
C4210	CHIP TYPE CERAMIC CAPACITOR	CK725B1H-332K1	1	332103325R1
C4211	VR TYPE ELECTROLYTIC CAPACITOR	CE04W50V-10M(VR)	1	394681007T
C4230	CHIP TYPE CERAMIC CAPACITOR	CC725CH1H-102J1	1	342101024R1
C4231	UTSP TYPE ELECTROLYTIC CAPACITOR	CE04W25V-100M(UTSP)	1	397551017AT
C4232	UTSP TYPE ELECTROLYTIC CAPACITOR	CE04W25V-100M(UTSP)	1	397551017AT
C4241	UTSP TYPE ELECTROLYTIC CAPACITOR	CE04W50V 47M(UTSP)	1	397584707AT
C4242	UTSP TYPE ELECTROLYTIC CAPACITOR	CE04W50V 47M(UTSP)	1	397584707AT
C4251	CHIP TYPE CERAMIC CAPACITOR	CC725CH1H-221J1	1	342102214R1
C4252	CHIP TYPE CERAMIC CAPACITOR	CC725CH1H-221J1	1	342102214R1
C4253	CHIP TYPE CERAMIC CAPACITOR	CC725CH1H-221J1	1	342102214R1
C4254	CHIP TYPE CERAMIC CAPACITOR	CC725CH1H-221J1	1	342102214R1
C4255	CHIP TYPE CERAMIC CAPACITOR	CK725B1C-104K1	1	332121045R1
C4301	UTSP TYPE ELECTROLYTIC CAPACITOR	CE04W50V 47M(UTSP)	1	397584707AT
C4302	UTSP TYPE ELECTROLYTIC CAPACITOR	CE04W50V 47M(UTSP)	1	397584707AT
C4303	UTSP TYPE ELECTROLYTIC CAPACITOR	CE04W25V-100M(UTSP)	1	397551017AT
C4304	UTSP TYPE ELECTROLYTIC CAPACITOR	CE04W25V-100M(UTSP)	1	397551017AT
C4305	CHIP TYPE CERAMIC CAPACITOR	CK725B1H-104K1	1	332101045R1
C4306	CHIP TYPE CERAMIC CAPACITOR	CK725B1H-104K1	1	332101045R1
C4307	VR TYPE ELECTROLYTIC CAPACITOR	CE04W50V-4.7M(VR)	1	394680477T
C4308	VR TYPE ELECTROLYTIC CAPACITOR	CE04W50V-4.7M(VR)	1	394680477T
C4309	CHIP TYPE CERAMIC CAPACITOR	CK725B1H-332K1	1	332103325R1
C4310	CHIP TYPE CERAMIC CAPACITOR	CK725B1H-332K1	1	332103325R1
C4311	VR TYPE ELECTROLYTIC CAPACITOR	CE04W50V-10M(VR)	1	394681007T
C4330	CHIP TYPE CERAMIC CAPACITOR	CC725CH1H-102J1	1	342101024R1
C4331	UTSP TYPE ELECTROLYTIC CAPACITOR	CE04W25V-100M(UTSP)	1	397551017AT
C4332	UTSP TYPE ELECTROLYTIC CAPACITOR	CE04W25V-100M(UTSP)	1	397551017AT
C4341	UTSP TYPE ELECTROLYTIC CAPACITOR	CE04W50V 47M(UTSP)	1	397584707AT
C4342	UTSP TYPE ELECTROLYTIC CAPACITOR	CE04W50V 47M(UTSP)	1	397584707AT
C4600	UTSJ C	CE04W50V-47M(UTSJ)	1	398084707BT
C4601	UTSJ C	CE04W50V-47M(UTSJ)	1	398084707BT
C4602	UTSJ C	CE04W50V-47M(UTSJ)	1	398084707BT
C4603	UTSJ C	CE04W50V-47M(UTSJ)	1	398084707BT
C4604	UTSJ C	CE04W50V-47M(UTSJ)	1	398084707BT
C4605	UTSJ C	CE04W50V-47M(UTSJ)	1	398084707BT
C4606	UTSJ C	CE04W50V-47M(UTSJ)	1	398084707BT
C4607	UTSP TYPE ELECTROLYTIC CAPACITOR	CE04W50V-22M(UTSP)	1	397582207AT
C4609	UTSP TYPE ELECTROLYTIC CAPACITOR	CE04W50V-22M(UTSP)	1	397582207AT
C4610	UPZ TYPE PLASTIC FILM CAPACITOR	2AUPZTF221JE	1	376332214T
C4611	UPZ TYPE PLASTIC FILM CAPACITOR	2AUPZTF221JE	1	376332214T
C4612	CHIP TYPE CERAMIC CAPACITOR	CC725CH1H-221J1	1	342102214R1
C4613	CHIP TYPE CERAMIC CAPACITOR	CC725CH1H-221J1	1	342102214R1
C4614	CHIP TYPE CERAMIC CAPACITOR	CC725CH1H-221J1	1	342102214R1
C4615	CHIP TYPE CERAMIC CAPACITOR	CC725CH1H-221J1	1	342102214R1
C4616	CHIP TYPE CERAMIC CAPACITOR	CC725CH1H-221J1	1	342102214R1
C4617	CHIP TYPE CERAMIC CAPACITOR	CC725CH1H-221J1	1	342102214R1
C4618	CHIP TYPE CERAMIC CAPACITOR	CC725CH1H-221J1	1	342102214R1
C4619	CHIP TYPE CERAMIC CAPACITOR	CC725CH1H-221J1	1	342102214R1
C4620	CHIP TYPE CERAMIC CAPACITOR	CC725CH1H-221J1	1	342102214R1
C4690	TF TYPE PLASTIC FILM CAPACITOR	ECQ-V50V-104J	1	374721044T
C4690 or	FILM C	C281H104J20A21A	( 1 )	376821044T
C4700	CHIP TYPE CERAMIC CAPACITOR	CK725B1H-104K1	1	332101045R1
C4701	CHIP TYPE CERAMIC CAPACITOR	CK725B1H-104K1	1	332101045R1
C4702	CHIP TYPE CERAMIC CAPACITOR	CK725B1H-104K1	1	332101045R1
C4850	UMXR TYPE PLASTIC FILM CAPACITOR	1JUMXRTF102JE	1	376591024T



C4851	UMXR TYPE PLASTIC FILM CAPACITOR	1JUMXRTF102JE	1	376591024T
C4852	UMXR TYPE PLASTIC FILM CAPACITOR	1JUMXRTF102JE	1	376591024T
C4853	UMXR TYPE PLASTIC FILM CAPACITOR	1JUMXRTF102JE	1	376591024T
C4861	CHIP TYPE CERAMIC CAPACITOR	CK725B1H-102K1	1	332101025R1
C4862	CHIP TYPE CERAMIC CAPACITOR	CK725B1H-102K1	1	332101025R1
C4901	UTSP TYPE ELECTROLYTIC CAPACITOR	CE04W50V-22M(UTSP)	1	397582207AT
C4902	UTSP TYPE ELECTROLYTIC CAPACITOR	CE04W50V-22M(UTSP)	1	397582207AT
C4903	UTSP TYPE ELECTROLYTIC CAPACITOR	CE04W25V-220M(UTSP)	1	397552217T
C4904	UTSP TYPE ELECTROLYTIC CAPACITOR	CE04W25V-220M(UTSP)	1	397552217T
C4907	JAMICON TYPE ELECTROLYTIC CAPACITOR	CE04W16V-100M	1	398541017T
C4908	JAMICON TYPE ELECTROLYTIC CAPACITOR	CE04W16V-100M	1	398541017T
C4909	UTSP TYPE ELECTROLYTIC CAPACITOR	CE04W25V-220M(UTSP)	1	397552217T
C4910	UTSP TYPE ELECTROLYTIC CAPACITOR	CE04W25V-220M(UTSP)	1	397552217T
C4911	CHIP TYPE CERAMIC CAPACITOR	CK725B1H-104K1	1	332101045R1
C4912	CHIP TYPE CERAMIC CAPACITOR	CK725B1H-104K1	1	332101045R1
C4913	JAMICON TYPE ELECTROLYTIC CAPACITOR	CE04W16V-100M	1	398541017T
C4914	JAMICON TYPE ELECTROLYTIC CAPACITOR	CE04W16V-100M	1	398541017T
<b>[RESISTOR]</b>				
R2001	CHIP TYPE CARBON RESISTOR	RN72K1J-101JE	1	435031014R1
R2002	CHIP TYPE CARBON RESISTOR	RN72K1J-101JE	1	435031014R1
R2003	CHIP TYPE CARBON RESISTOR	RN72K1J-222JE	1	435032224R1
R2004	CHIP TYPE CARBON RESISTOR	RN72K1J-222JE	1	435032224R1
R2005	CHIP TYPE CARBON RESISTOR	RN72K1J-103JE	1	435031034R1
R2006	CHIP TYPE CARBON RESISTOR	RN72K1J-563JE	1	435035634R1
R2007	CHIP TYPE CARBON RESISTOR	RN72K1J-561JE	1	435035614R1
R2008	CHIP TYPE CARBON RESISTOR	RN72K1J-561JE	1	435035614R1
R2015	CHIP TYPE CARBON RESISTOR	RN72K1J-563JE	1	435035634R1
R2016	CHIP TYPE CARBON RESISTOR	RN72K1J-103JE	1	435031034R1
R2026	CHIP TYPE CARBON RESISTOR	RN72K1J-103JE	1	435031034R1
R2027	CHIP TYPE CARBON RESISTOR	RN72K1J-103JE	1	435031034R1
R2101	CHIP TYPE CARBON RESISTOR	RN72K1J-750JE	1	435037504R1
R2102	CHIP TYPE CARBON RESISTOR	RN72K1J-750JE	1	435037504R1
R2103	CHIP TYPE CARBON RESISTOR	RN72K1J-750JE	1	435037504R1
R2104	CHIP TYPE CARBON RESISTOR	RN72K1J-104JE	1	435031044R1
R2105	CHIP TYPE CARBON RESISTOR	RN72K1J-750JE	1	435037504R1
R2106	CHIP TYPE CARBON RESISTOR	RN72K1J-750JE	1	435037504R1
R2107	CHIP TYPE CARBON RESISTOR	RN72K1J-750JE	1	435037504R1
R2108	CHIP TYPE CARBON RESISTOR	RN72K1J-750JE	1	435037504R1
R2109	CHIP TYPE CARBON RESISTOR	RN72K1J-750JE	1	435037504R1
R2110	CHIP TYPE CARBON RESISTOR	RN72K1J-750JE	1	435037504R1
R2111	CHIP TYPE CARBON RESISTOR	RN72K1J-750JE	1	435037504R1
R2112	CHIP TYPE CARBON RESISTOR	RN72K1J-104JE	1	435031044R1
R2113	CHIP TYPE CARBON RESISTOR	RN72K1J-750JE	1	435037504R1
R2114	CHIP TYPE CARBON RESISTOR	RN72K1J-104JE	1	435031044R1
R2115	CHIP TYPE CARBON RESISTOR	RN72K1J-750JE	1	435037504R1
R2116	CHIP TYPE CARBON RESISTOR	RN72K1J-104JE	1	435031044R1
R2117	CHIP TYPE CARBON RESISTOR	RN72K1J-750JE	1	435037504R1
R2511	CHIP TYPE CARBON RESISTOR	RN72K1J-103JE	1	435031034R1
R2512	CHIP TYPE CARBON RESISTOR	RN72K1J-103JE	1	435031034R1
R2513	CHIP TYPE CARBON RESISTOR	RN72K1J-103JE	1	435031034R1
R2514	CHIP TYPE CARBON RESISTOR	RN72K1J-333JE	1	435033334R1
R2515	CHIP TYPE CARBON RESISTOR	RN72K1J-180JE	1	435031804R1
R2516	CHIP TYPE CARBON RESISTOR	RN72K1J-180JE	1	435031804R1
R2517	CHIP TYPE CARBON RESISTOR	RN72K1J-180JE	1	435031804R1
R2518	CHIP TYPE CARBON RESISTOR	RN72K1J-180JE	1	435031804R1
R2521	CHIP TYPE CARBON RESISTOR	RN72K1J-103JE	1	435031034R1
R2522	CHIP TYPE CARBON RESISTOR	RN72K1J-103JE	1	435031034R1
R2523	CHIP TYPE CARBON RESISTOR	RN72K1J-103JE	1	435031034R1
R2524	CHIP TYPE CARBON RESISTOR	RN72K1J-333JE	1	435033334R1
R2525	CHIP TYPE CARBON RESISTOR	RN72K1J-180JE	1	435031804R1
R2531	CHIP TYPE CARBON RESISTOR	RN72K1J-103JE	1	435031034R1
R2532	CHIP TYPE CARBON RESISTOR	RN72K1J-103JE	1	435031034R1

R2533	CHIP TYPE CARBON RESISTOR	RN72K1J-103JE	1	435031034R1
R2534	CHIP TYPE CARBON RESISTOR	RN72K1J-333JE	1	435033334R1
R2535	CHIP TYPE CARBON RESISTOR	RN72K1J-180JE	1	435031804R1
R2701	METAL OXIDE FILM RESISTOR	RS1/2WBJ-100	1	443521014T
R2702	CHIP TYPE CARBON RESISTOR	RN72K1J-512JE	1	435035124R1
R2703	CHIP TYPE CARBON RESISTOR	RN72K1J-101JE	1	435031014R1
R2704	CHIP TYPE CARBON RESISTOR	RN72K1J-103JE	1	435031034R1
R2705	CHIP TYPE CARBON RESISTOR	RN72K1J-392JE	1	435033924R1
R2706	CHIP TYPE CARBON RESISTOR	RN72K1J-331JE	1	435033314R1
R2708	CHIP TYPE CARBON RESISTOR	RN72K1J-224JE	1	435032244R1
R2713	CHIP TYPE CARBON RESISTOR	RN72K1J-331JE	1	435033314R1
R2800	CHIP TYPE CARBON RESISTOR	RN72K1J-103JE	1	435031034R1
R2801	CHIP TYPE CARBON RESISTOR	RN72K1J-103JE	1	435031034R1
R2802	CHIP TYPE CARBON RESISTOR	RN72K1J-331JE	1	435033314R1
R2803	CHIP TYPE CARBON RESISTOR	RN72K1J-331JE	1	435033314R1
R2804	CHIP TYPE CARBON RESISTOR	RN72K1J-331JE	1	435033314R1
R2805	CHIP TYPE CARBON RESISTOR	RN72K1J-331JE	1	435033314R1
R2806	CHIP TYPE CARBON RESISTOR	RN72K1J-103JE	1	435031034R1
R2901	CHIP TYPE CARBON RESISTOR	RN72K1J-000JE	1	435030004R1
R2902	CHIP TYPE CARBON RESISTOR	RN72K1J-000JE	1	435030004R1
R4000	CHIP TYPE CARBON RESISTOR	RN72K1J-471JE	1	435034714R1
R4001	CHIP TYPE CARBON RESISTOR	RN72K1J-471JE	1	435034714R1
R4002	CHIP TYPE CARBON RESISTOR	RN72K1J-471JE	1	435034714R1
R4003	CHIP TYPE CARBON RESISTOR	RN72K1J-471JE	1	435034714R1
R4004	CHIP TYPE CARBON RESISTOR	RN72K1J-471JE	1	435034714R1
R4005	CHIP TYPE CARBON RESISTOR	RN72K1J-471JE	1	435034714R1
R4006	CHIP TYPE CARBON RESISTOR	RN72K1J-471JE	1	435034714R1
R4007	CHIP TYPE CARBON RESISTOR	RN72K1J-471JE	1	435034714R1
R4008	CHIP TYPE CARBON RESISTOR	RN72K1J-471JE	1	435034714R1
R4009	CHIP TYPE CARBON RESISTOR	RN72K1J-471JE	1	435034714R1
R4012	CHIP TYPE CARBON RESISTOR	RN72K1J-471JE	1	435034714R1
R4013	CHIP TYPE CARBON RESISTOR	RN72K1J-471JE	1	435034714R1
R4014	CHIP TYPE CARBON RESISTOR	RN72K1J-471JE	1	435034714R1
R4015	CHIP TYPE CARBON RESISTOR	RN72K1J-471JE	1	435034714R1
R4016	CHIP TYPE CARBON RESISTOR	RN72K1J-471JE	1	435034714R1
R4017	CHIP TYPE CARBON RESISTOR	RN72K1J-471JE	1	435034714R1
R4018	CHIP TYPE CARBON RESISTOR	RN72K1J-224JE	1	435032244R1
R4019	CHIP TYPE CARBON RESISTOR	RN72K1J-224JE	1	435032244R1
R4020	CHIP TYPE CARBON RESISTOR	RN72K1J-224JE	1	435032244R1
R4021	CHIP TYPE CARBON RESISTOR	RN72K1J-224JE	1	435032244R1
R4022	CHIP TYPE CARBON RESISTOR	RN72K1J-224JE	1	435032244R1
R4023	CHIP TYPE CARBON RESISTOR	RN72K1J-224JE	1	435032244R1
R4024	CHIP TYPE CARBON RESISTOR	RN72K1J-224JE	1	435032244R1
R4025	CHIP TYPE CARBON RESISTOR	RN72K1J-224JE	1	435032244R1
R4026	CHIP TYPE CARBON RESISTOR	RN72K1J-224JE	1	435032244R1
R4027	CHIP TYPE CARBON RESISTOR	RN72K1J-224JE	1	435032244R1
R4030	CHIP TYPE CARBON RESISTOR	RN72K1J-224JE	1	435032244R1
R4031	CHIP TYPE CARBON RESISTOR	RN72K1J-224JE	1	435032244R1
R4032	CHIP TYPE CARBON RESISTOR	RN72K1J-224JE	1	435032244R1
R4033	CHIP TYPE CARBON RESISTOR	RN72K1J-224JE	1	435032244R1
R4034	CHIP TYPE CARBON RESISTOR	RN72K1J-563JE	1	435035634R1
R4035	CHIP TYPE CARBON RESISTOR	RN72K1J-563JE	1	435035634R1
R4053	CHIP TYPE CARBON RESISTOR	RN72K1J-104JE	1	435031044R1
R4054	CHIP TYPE CARBON RESISTOR	RN72K1J-224JE	1	435032244R1
R4055	CHIP TYPE CARBON RESISTOR	RN72K1J-224JE	1	435032244R1
R4070	CHIP TYPE CARBON RESISTOR	RN72K1J-101JE	1	435031014R1
R4071	CHIP TYPE CARBON RESISTOR	RN72K1J-101JE	1	435031014R1
R4072	CHIP TYPE CARBON RESISTOR	RN72K1J-101JE	1	435031014R1
R4101	CHIP TYPE CARBON RESISTOR	RN72K1J-223JE	1	435032234R1
R4102	CHIP TYPE CARBON RESISTOR	RN72K1J-223JE	1	435032234R1
R4103	CHIP TYPE CARBON RESISTOR	RN72K1J-332JE	1	435033324R1
R4104	CHIP TYPE CARBON RESISTOR	RN72K1J-332JE	1	435033324R1





R4645	CHIP TYPE CARBON RESISTOR	RN72K1J-470JE	1	435034704R1
R4646	CHIP TYPE CARBON RESISTOR	RN72K1J-470JE	1	435034704R1
R4647	CHIP TYPE CARBON RESISTOR	RN72K1J-470JE	1	435034704R1
R4648	CHIP TYPE CARBON RESISTOR	RN72K1J-470JE	1	435034704R1
R4649	CHIP TYPE CARBON RESISTOR	RN72K1J-470JE	1	435034704R1
R4650	CHIP TYPE CARBON RESISTOR	RN72K1J-224JE	1	435032244R1
R4651	CHIP TYPE CARBON RESISTOR	RN72K1J-221JE	1	435032214R1
R4652	CHIP TYPE CARBON RESISTOR	RN72K1J-221JE	1	435032214R1
R4660	CHIP TYPE CARBON RESISTOR	RN72K1J-470JE	1	435034704R1
R4661	CHIP TYPE CARBON RESISTOR	RN72K1J-101JE	1	435031014R1
R4662	CHIP TYPE CARBON RESISTOR	RN72K1J-101JE	1	435031014R1
R4670	CHIP TYPE CARBON RESISTOR	RN72K1J-221JE	1	435032214R1
R4680	CHIP TYPE CARBON RESISTOR	RN72K1J-101JE	1	435031014R1
R4690	CHIP TYPE CARBON RESISTOR	RN72K1J-102JE	1	435031024R1
R4691	CHIP TYPE CARBON RESISTOR	RN72K1J-224JE	1	435032244R1
R4692	CHIP TYPE CARBON RESISTOR	RN72K1J-224JE	1	435032244R1
R4693	CHIP TYPE CARBON RESISTOR	RN72K1J-224JE	1	435032244R1
R4694	CHIP TYPE CARBON RESISTOR	RN72K1J-224JE	1	435032244R1
R4695	CHIP TYPE CARBON RESISTOR	RN72K1J-224JE	1	435032244R1
R4696	CHIP TYPE CARBON RESISTOR	RN72K1J-224JE	1	435032244R1
R4701	CHIP TYPE CARBON RESISTOR	RN72K1J-000JE	1	435030004R1
R4702	CHIP TYPE CARBON RESISTOR	RN72K1J-000JE	1	435030004R1
R4703	CHIP TYPE CARBON RESISTOR	RN72K1J-000JE	1	435030004R1
R4704	CHIP TYPE CARBON RESISTOR	RN72K1J-000JE	1	435030004R1
R4705	CHIP TYPE CARBON RESISTOR	RN72K1J-000JE	1	435030004R1
R4706	CHIP TYPE CARBON RESISTOR	RN72K1J-000JE	1	435030004R1
R4707	CHIP TYPE CARBON RESISTOR	RN72K1J-000JE	1	435030004R1
R4708	CHIP TYPE CARBON RESISTOR	RN72K1J-000JE	1	435030004R1
R4709	CHIP TYPE CARBON RESISTOR	RN72K2E-000JE	1	435220004R1
R4710	CHIP TYPE CARBON RESISTOR	RN72K2E-000JE	1	435220004R1
R4711	CHIP TYPE CARBON RESISTOR	RN72K1J-000JE	1	435030004R1
R4712	CHIP TYPE CARBON RESISTOR	RN72K1J-000JE	1	435030004R1
R4713	CHIP TYPE CARBON RESISTOR	RN72K1J-000JE	1	435030004R1
R4715	CHIP TYPE CARBON RESISTOR	RN72K1J-000JE	1	435030004R1
R4716	CHIP TYPE CARBON RESISTOR	RN72K1J-000JE	1	435030004R1
R4717	CHIP TYPE CARBON RESISTOR	RN72K1J-000JE	1	435030004R1
R4861	CHIP TYPE CARBON RESISTOR	RN72K1J-224JE	1	435032244R1
R4862	CHIP TYPE CARBON RESISTOR	RN72K1J-224JE	1	435032244R1
R4863	CHIP TYPE CARBON RESISTOR	RN72K1J-102JE	1	435031024R1
R4864	CHIP TYPE CARBON RESISTOR	RN72K1J-102JE	1	435031024R1
R4901	CHIP TYPE CARBON RESISTOR	RN72K1J-472JE	1	435034724R1
R4902	CHIP TYPE CARBON RESISTOR	RN72K1J-472JE	1	435034724R1
R4903	CHIP TYPE CARBON RESISTOR	RN72K1J-561JE	1	435035614R1
R4904	CHIP TYPE CARBON RESISTOR	RN72K1J-561JE	1	435035614R1
R4905	CHIP TYPE CARBON RESISTOR	RN72K2E-220JE	1	435222204R1
R4906	CHIP TYPE CARBON RESISTOR	RN72K2E-220JE	1	435222204R1
R4907	CHIP TYPE CARBON RESISTOR	RN72K1J-100JE	1	435031004R1
R4908	CHIP TYPE CARBON RESISTOR	RN72K1J-100JE	1	435031004R1
R4909	CHIP TYPE CARBON RESISTOR	RN72K1J-151JE	1	435031514R1
R4910	CHIP TYPE CARBON RESISTOR	RN72K1J-151JE	1	435031514R1
R4911	CHIP TYPE CARBON RESISTOR	RN72K1J-151JE	1	435031514R1
R4912	CHIP TYPE CARBON RESISTOR	RN72K1J-151JE	1	435031514R1
R4913	CHIP TYPE CARBON RESISTOR	RN72K1J-100JE	1	435031004R1
R4914	CHIP TYPE CARBON RESISTOR	RN72K1J-100JE	1	435031004R1
R4915	CHIP TYPE CARBON RESISTOR	RN72K2E-000JE	1	435220004R1
R4916	CHIP TYPE CARBON RESISTOR	RN72K2E-000JE	1	435220004R1
R4917	CHIP TYPE CARBON RESISTOR	RN72K2E-000JE	1	435220004R1
R4918	CHIP TYPE CARBON RESISTOR	RN72K2E-000JE	1	435220004R1
<b>[SW TRM]</b>				
F2901	FUSE	T6.3A-SEUL-T250V	1	252399T !
F2951	FUSE	T1A-SEUL-T250V	1	252397T !
P2003	PLUG	NPLG-5P119	1	25055135

P2005	RETAINER	(PC-HOLD)	1	27142149
P2101	PIN JACK	NPJ-3PDYYY681	1	25045913
P2101A	SOCKET	NSCT-11P2191	1	25052294
P2102	PIN JACK	NPJ-1PDY655	1	25045882
P2103	PIN JACK	NPJ-9PDGLR630	1	25045851
P2200	WIRE HARNESS ASSEMBLY	NSAS-7P2125	1	2009991314UL
P2200A	WIRE HOL	CHD-1.5-7	1	25053537
P2200Aor	WIRE HOL	NSCT-7P878	( 1)	25051091
P2201A	SOCKET	NSCT-40P2237	1	25052340
P2203A	SOCKET	NSCT-15P2433	1	25052536
P2204A	SOCKET	NSCT-7P2100	1	25052203
P2700	ST JACK	HSJ1002-01-6020	1	25045647
P2701	ST JACK	HSJ1002-01-6020	1	25045647
P2702	ST JACK	HSJ1002-01-6020	1	25045647
P2800	SOCKET	MDS-09P-V-01(DSUB9P)	1	25053363
P4000	PIN JACK	NPJ-6PDRW665	1	25045894
P4001	PIN JACK	NPJ-4PDRW592	1	25045812
P4003	PIN JACK	NPJ-6PDRW665	1	25045894
P4031	RETAINER	(TRM)	1	25060507
P4251	PIN JACK	NPJ-4PDRW592	1	25045812
P4511A	PLUG	IMSA-9142B-26A	1	25056603
P4600	PIN JACK	NPJ-2PDWR583	1	25045803
P4601	PIN JACK	NPJ-1PDG742	1	25045992
P4602	PIN JACK	NPJ-6PDLENTP702	1	25045936
P4603	PIN JACK	NPJ-2PDWR583	1	25045803
P4604B	PLUG	NPLG-13P141	1	25055157
P4605A	SOCKET	NSCT-9P2102	1	25052205
P4605B	SOCKET	NSCT-9P2102	1	25052205
P4606B	PLUG	NPLG-3P131	1	25055147
P4880A	WIRE HOL	CHD-1.5-7	1	25053537
P4880Aor	WIRE HOL	NSCT-7P878	( 1)	25051091
P4880B	WIRE HOL	CHD-1.5-7	1	25053537
P4880Bor	WIRE HOL	NSCT-7P878	( 1)	25051091
P7001B	SOCKET	NSCT-13P2404	1	25052507
P9000B	PLUG	NPLG-5P133	1	25055149
P9201B	PLUG	NPLG-5P133	1	25055149
RL4700	RELAY	NRL-2P2A-DC12-207	1	25065726
RL4700 or	RELAY	NRL-2P2A-DC12-178	( 1)	25065664
RL4701	RELAY	NRL-2P2A-DC12-207	1	25065726
RL4701 or	RELAY	NRL-2P2A-DC12-178	( 1)	25065664
RL4702	RELAY	NRL-2P2A-DC12-207	1	25065726
RL4702 or	RELAY	NRL-2P2A-DC12-178	( 1)	25065664

**U002**

BADG-1800-1D

: NSP

CIRCUIT NO	PART NAME	DESCRIPTION	Q'TY	PART NO. (SN)	REMARKS
<b>[SEMI CONDUCTOR]</b>					
D1200	CHIP TYPE DIODE	DA2J10100	1	223303R2	
D1200 or	CHIP TYPE DIODE	1SS352	( 1)	223234R2	
D1201	CHIP TYPE DIODE	DA2J10100	1	223303R2	
D1201 or	CHIP TYPE DIODE	1SS352	( 1)	223234R2	
D1202	CHIP TYPE DIODE	DA2J10100	1	223303R2	
D1202 or	CHIP TYPE DIODE	1SS352	( 1)	223234R2	
D1203	CHIP TYPE DIODE	DA2J10100	1	223303R2	
D1203 or	CHIP TYPE DIODE	1SS352	( 1)	223234R2	
D1204	CHIP TYPE DIODE	DA2J10100	1	223303R2	
D1204 or	CHIP TYPE DIODE	1SS352	( 1)	223234R2	
D1205	CHIP TYPE DIODE	DA2J10100	1	223303R2	
D1205 or	CHIP TYPE DIODE	1SS352	( 1)	223234R2	

D1206	CHIP TYPE DIODE	DA2J10100	1	223303R2
D1206 or	CHIP TYPE DIODE	1SS352	( 1)	223234R2
D1207	CHIP TYPE DIODE	DA2J10100	1	223303R2
D1207 or	CHIP TYPE DIODE	1SS352	( 1)	223234R2
Q1000	HYBRID IC	TC74HCU04AF	1	222740046R2TO
Q1100	HYBRID IC	S-13A1A33-U5T1U3	1	22242844R2
Q1200	HYBRID IC	PCM9211PTR	1	22242703R2
Q1201	HYBRID IC	PCM9211PTR	1	22242703R2
Q1202	HYBRID IC	TC7SZU04FU	1	22242512R2TO
Q1301	HYBRID IC	AK4458VN	1	22242927R2
Q1400	HYBRID IC	NE5532APSR	1	22242283R2
Q1401	HYBRID IC	NJM4580CG	1	22242922R2
Q1402	HYBRID IC	NJM4580CG	1	22242922R2
Q1403	HYBRID IC	NJM4580CG	1	22242922R2
Q1410	HYBRID IC	NE5532APSR	1	22242283R2
Q1420	HYBRID IC	NE5532APSR	1	22242283R2
Q1430	HYBRID IC	NE5532APSR	1	22242283R2
Q1440	HYBRID IC	NE5532APSR	1	22242283R2
<b>[TRANS COIL]</b>				
L1000	EMI SUPPRESSION FILTER	BK1608HS102-T	1	230955R2
L1001	EMI SUPPRESSION FILTER	BK1608HS102-T	1	230955R2
L1003	CHOKE COIL	LBC2518T470M	1	231364M470R2
L1201	CHOKE COIL	LBC2518T4R7M	1	231364M047R2
L1202	CHOKE COIL	LBC2518T4R7M	1	231364M047R2
L1203	CORE	MMZ1608Y601BT	1	2350004R1
L1204	CORE	MMZ1608Y601BT	1	2350004R1
L1205	CORE	MMZ1608Y601BT	1	2350004R1
L1206	CORE	BLM18PG181SN1D	1	2350005R1
L1207	CORE	MMZ1608Y601BT	1	2350004R1
L1208	CHOKE COIL	LBC2518T4R7M	1	231364M047R2
L1209	CHOKE COIL	LBC2518T4R7M	1	231364M047R2
L1210	CORE	MMZ1608Y601BT	1	2350004R1
L1211	CORE	BLM18PG181SN1D	1	2350005R1
L1212	CORE	BLM18PG181SN1D	1	2350005R1
L1301	CHOKE COIL	LBC2518T4R7M	1	231364M047R2
L1302	CHOKE COIL	LBC2518T4R7M	1	231364M047R2
X1201	CRYSTAL	HC-49S 9C22.5792M	1	3010535R2
<b>[CAPACITOR]</b>				
C1002	CHIP TYPE CERAMIC CAPACITOR	CK725B1C-104K0	1	332011045R1
C1003	CHIP TYPE CERAMIC CAPACITOR	CK725B1C-104K0	1	332011045R1
C1006	CHIP TYPE CERAMIC CAPACITOR	CK725B1C-104K0	1	332011045R1
C1007	CHIP TYPE CERAMIC CAPACITOR	CK725B1C-104K0	1	332011045R1
C1008	CHIP TYPE CERAMIC CAPACITOR	CK725B1C-104K0	1	332011045R1
C1010	CHIP TYPE CERAMIC CAPACITOR	CC725CH1H-080D1	1	342100802R1
C1011	CHIP TYPE CERAMIC CAPACITOR	CC725CH1H-080D1	1	342100802R1
C1012	CHIP TYPE CERAMIC CAPACITOR	CK725B1C-104K0	1	332011045R1
C1013	UTSP TYPE ELECTROLYTIC CAPACITOR	CE04W10V-220M(UTSP)	1	397532217AT
C1100	CHIP TYPE CERAMIC CAPACITOR	CK732B16V-106K	1	332071065R2
C1101	CHIP TYPE CERAMIC CAPACITOR	CK732B16V-106K	1	332071065R2
C1200	UTSP TYPE ELECTROLYTIC CAPACITOR	CE04W10V-220M(UTSP)	1	397532217AT
C1201	CHIP TYPE CERAMIC CAPACITOR	CK725B1C-104K0	1	332011045R1
C1202	UTSP TYPE ELECTROLYTIC CAPACITOR	CE04W10V-220M(UTSP)	1	397532217AT
C1203	CHIP TYPE CERAMIC CAPACITOR	CK725B1C-104K0	1	332011045R1
C1206	CHIP TYPE CERAMIC CAPACITOR	CK725B1H-472K0	1	332034725R1
C1207	CHIP TYPE CERAMIC CAPACITOR	CK725B1H-223K0	1	332032235R1
C1208	CHIP TYPE CERAMIC CAPACITOR	CK725B1E-473K0	1	332024735R1
C1209	UTSP TYPE ELECTROLYTIC CAPACITOR	CE04W10V-220M(UTSP)	1	397532217AT
C1210	CHIP TYPE CERAMIC CAPACITOR	CK725B1C-104K0	1	332011045R1
C1211	CHIP TYPE CERAMIC CAPACITOR	CK725B1C-104K0	1	332011045R1
C1212	CHIP TYPE CERAMIC CAPACITOR	CC725CH1H-150J0	1	342031504R1
C1213	CHIP TYPE CERAMIC CAPACITOR	CC725CH1H-180J0	1	342031804R1
C1214	CHIP TYPE CERAMIC CAPACITOR	CK725B1H-102K0	1	332031025R1



C1215	CHIP TYPE CERAMIC CAPACITOR	CK725B1C-104K0	1	332011045R1	
C1216	CHIP TYPE CERAMIC CAPACITOR	CK725B1H-102K0	1	332031025R1	
C1217	UTSP TYPE ELECTROLYTIC CAPACITOR	CE04W10V-220M(UTSP)	1	397532217AT	
C1218	CHIP TYPE CERAMIC CAPACITOR	CK725B1C-104K0	1	332011045R1	
C1219	CHIP TYPE CERAMIC CAPACITOR	CK725B1H-472K0	1	332034725R1	
C1220	CHIP TYPE CERAMIC CAPACITOR	CK725B1H-223K0	1	332032235R1	
C1221	CHIP TYPE CERAMIC CAPACITOR	CK725B1E-473K0	1	332024735R1	
C1222	UTSP TYPE ELECTROLYTIC CAPACITOR	CE04W50V-47M(UTSP)	1	397584707AT	
C1223	CHIP TYPE CERAMIC CAPACITOR	CK725B1C-104K0	1	332011045R1	
C1224	UTSP TYPE ELECTROLYTIC CAPACITOR	CE04W10V-220M(UTSP)	1	397532217AT	
C1225	UTSP TYPE ELECTROLYTIC CAPACITOR	CE04W25V-47M(UTSP)	1	397554707AT	
C1226	UTSP TYPE ELECTROLYTIC CAPACITOR	CE04W25V-47M(UTSP)	1	397554707AT	
C1227	CHIP TYPE CERAMIC CAPACITOR	CK725B1C-104K0	1	332011045R1	
C1228	CHIP TYPE CERAMIC CAPACITOR	CK725B1C-104K0	1	332011045R1	
C1231	UTSJ C	CE04W50V-47M(UTSJ)	1	398084707BT	
C1235	CHIP TYPE CERAMIC CAPACITOR	CC725CH1H-330J0	1	342033304R1	
C1236	CHIP TYPE CERAMIC CAPACITOR	CC725CH1H-330J0	1	342033304R1	
C1241	CHIP TYPE CERAMIC CAPACITOR	CC725CH1H-330J0	1	342033304R1	
C1242	CHIP TYPE CERAMIC CAPACITOR	CC725CH1H-330J0	1	342033304R1	
C1243	UTSP TYPE ELECTROLYTIC CAPACITOR	CE04W10V-220M(UTSP)	1	397532217AT	
C1244	CHIP TYPE CERAMIC CAPACITOR	CK725B1H-102K0	1	332031025R1	
C1245	CHIP TYPE CERAMIC CAPACITOR	CK725B1H-102K0	1	332031025R1	
C1313	CHIP TYPE CERAMIC CAPACITOR	CK725B1H-102K0	1	332031025R1	
C1314	UTSP TYPE ELECTROLYTIC CAPACITOR	CE04W10V-220M(UTSP)	1	397532217AT	
C1315	CHIP TYPE PLASTIC FILM CAPACITOR	50ST104MA13216	1	376721047R2	
C1316	UTSJ C	CE04W25V-220M(UTSJ)	1	398052217AT	
C1317	CHIP TYPE PLASTIC FILM CAPACITOR	50ST104MA13216	1	376721047R2	
C1318	UTSP TYPE ELECTROLYTIC CAPACITOR	CE04W50V-10M(UTSP)	1	397581007AT	
C1319	CHIP TYPE PLASTIC FILM CAPACITOR	50ST104MA13216	1	376721047R2	
C1320	UTSP TYPE ELECTROLYTIC CAPACITOR	CE04W10V-220M(UTSP)	1	397532217AT	
C1321	CHIP TYPE PLASTIC FILM CAPACITOR	50ST104MA13216	1	376721047R2	
C1322	UTSP TYPE ELECTROLYTIC CAPACITOR	CE04W50V-10M(UTSP)	1	397581007AT	
C1333	UTSP TYPE ELECTROLYTIC CAPACITOR	CE04W50V-10M(UTSP)	1	397581007AT	
C1334	CHIP TYPE PLASTIC FILM CAPACITOR	50ST104MA13216	1	376721047R2	
C1335	CHIP TYPE CERAMIC CAPACITOR	CK725B1C-104K0	1	332011045R1	
C1336	CHIP TYPE CERAMIC CAPACITOR	CK725B1A-105K0	1	332001055R1	
C1337	UTSP TYPE ELECTROLYTIC CAPACITOR	CE04W16V-470M(UTSP)	1	397544717T	
C1338	UTSP TYPE ELECTROLYTIC CAPACITOR	CE04W16V-470M(UTSP)	1	397544717T	
C1339	UTSP TYPE ELECTROLYTIC CAPACITOR	CE04W25V-220M(UTSP)	1	397552217T	
C1340	UTSP TYPE ELECTROLYTIC CAPACITOR	CE04W25V-220M(UTSP)	1	397552217T	
C1400	UMXR TYPE PLASTIC FILM CAPACITOR	1JUMXRTF392JE	1	376593924T	N
C1401	UMXR TYPE PLASTIC FILM CAPACITOR	1JUMXRTF392JE	1	376593924T	N
C1402	UMXR TYPE PLASTIC FILM CAPACITOR	1JUMXRTF392JE	1	376593924T	N
C1403	UMXR TYPE PLASTIC FILM CAPACITOR	1JUMXRTF392JE	1	376593924T	N
C1404	UMXR TYPE PLASTIC FILM CAPACITOR	1JUMXRTF392JE	1	376593924T	N
C1405	UMXR TYPE PLASTIC FILM CAPACITOR	1JUMXRTF392JE	1	376593924T	N
C1406	UMXR TYPE PLASTIC FILM CAPACITOR	1JUMXRTF392JE	1	376593924T	N
C1407	UMXR TYPE PLASTIC FILM CAPACITOR	1JUMXRTF392JE	1	376593924T	N
C1410	UPZ TYPE PLASTIC FILM CAPACITOR	2AUPZTF681JE	1	376336814T	
C1411	UPZ TYPE PLASTIC FILM CAPACITOR	2AUPZTF681JE	1	376336814T	
C1412	UPZ TYPE PLASTIC FILM CAPACITOR	2AUPZTF681JE	1	376336814T	
C1413	UPZ TYPE PLASTIC FILM CAPACITOR	2AUPZTF681JE	1	376336814T	
C1414	UPZ TYPE PLASTIC FILM CAPACITOR	2AUPZTF681JE	1	376336814T	
C1415	UPZ TYPE PLASTIC FILM CAPACITOR	2AUPZTF681JE	1	376336814T	
C1416	UPZ TYPE PLASTIC FILM CAPACITOR	2AUPZTF681JE	1	376336814T	
C1417	UPZ TYPE PLASTIC FILM CAPACITOR	2AUPZTF681JE	1	376336814T	
C1420	UPZ TYPE PLASTIC FILM CAPACITOR	2AUPZTF681JE	1	376336814T	
C1421	UPZ TYPE PLASTIC FILM CAPACITOR	2AUPZTF681JE	1	376336814T	
C1422	UPZ TYPE PLASTIC FILM CAPACITOR	2AUPZTF681JE	1	376336814T	
C1423	UPZ TYPE PLASTIC FILM CAPACITOR	2AUPZTF681JE	1	376336814T	
C1424	UPZ TYPE PLASTIC FILM CAPACITOR	2AUPZTF681JE	1	376336814T	
C1425	UPZ TYPE PLASTIC FILM CAPACITOR	2AUPZTF681JE	1	376336814T	



C1426	UPZ TYPE PLASTIC FILM CAPACITOR	2AUPZTF681JE	1	376336814T
C1427	UPZ TYPE PLASTIC FILM CAPACITOR	2AUPZTF681JE	1	376336814T
C1430	UMXR TYPE PLASTIC FILM CAPACITOR	1JUMXRTF222JE	1	376592224T
C1431	UMXR TYPE PLASTIC FILM CAPACITOR	1JUMXRTF222JE	1	376592224T
C1440	UPZ TYPE PLASTIC FILM CAPACITOR	2AUPZTF471JE	1	376334714T
C1441	UPZ TYPE PLASTIC FILM CAPACITOR	2AUPZTF471JE	1	376334714T
C1450	UPZ TYPE PLASTIC FILM CAPACITOR	2AUPZTF101JE	1	376331014T
C1451	UPZ TYPE PLASTIC FILM CAPACITOR	2AUPZTF101JE	1	376331014T
C1460	UMXR TYPE PLASTIC FILM CAPACITOR	1JUMXRTF222JE	1	376592224T
C1461	UMXR TYPE PLASTIC FILM CAPACITOR	1JUMXRTF222JE	1	376592224T
<b>[RESISTOR]</b>				
R1000	CHIP TYPE CARBON RESISTOR	RN72K1J-221JE	1	435032214R1
R1001	CHIP TYPE CARBON RESISTOR	RN72K1J-750JE	1	435037504R1
R1002	CHIP TYPE CARBON RESISTOR	RN72K1J-750JE	1	435037504R1
R1003	CHIP TYPE CARBON RESISTOR	RN72K1J-100JE	1	435031004R1
R1006	CHIP TYPE CARBON RESISTOR	RN72K1J-470JE	1	435034704R1
R1007	CHIP TYPE CARBON RESISTOR	RN72K1J-470JE	1	435034704R1
R1008	CHIP TYPE CARBON RESISTOR	RN72K1J-470JE	1	435034704R1
R1009	CHIP TYPE CARBON RESISTOR	RN72K1J-823JE	1	435038234R1
R1010	CHIP TYPE CARBON RESISTOR	RN72K1J-103JE	1	435031034R1
R1011	CHIP TYPE CARBON RESISTOR	RN72K1J-823JE	1	435038234R1
R1012	CHIP TYPE CARBON RESISTOR	RN72K1J-103JE	1	435031034R1
R1013	CHIP TYPE CARBON RESISTOR	RN72K1J-100JE	1	435031004R1
R1100	CHIP TYPE CARBON RESISTOR	RN72K1J-473JE	1	435034734R1
R1200	CHIP TYPE CARBON RESISTOR	RN72K1J-331JE	1	435033314R1
R1201	CHIP TYPE CARBON RESISTOR	RN72K1J-331JE	1	435033314R1
R1202	CHIP TYPE CARBON RESISTOR	RN72K1J-331JE	1	435033314R1
R1203	CHIP TYPE CARBON RESISTOR	RN72K1J-331JE	1	435033314R1
R1204	CHIP TYPE CARBON RESISTOR	RN72K1J-331JE	1	435033314R1
R1205	CHIP TYPE CARBON RESISTOR	RN72K1J-331JE	1	435033314R1
R1206	CHIP TYPE CARBON RESISTOR	RN72K1J-331JE	1	435033314R1
R1207	CHIP TYPE CARBON RESISTOR	RN72K1J-221JE	1	435032214R1
R1208	CHIP TYPE CARBON RESISTOR	RN72K1J-103JE	1	435031034R1
R1209	CHIP TYPE CARBON RESISTOR	RN72K1J-103JE	1	435031034R1
R1210	CHIP TYPE CARBON RESISTOR	RN72K1J-221JE	1	435032214R1
R1211	CHIP TYPE CARBON RESISTOR	RN72K1J-681JE	1	435036814R1
R1212	CHIP TYPE CARBON RESISTOR	RN72K1J-682JE	1	435036824R1
R1213	CHIP TYPE CARBON RESISTOR	RN72K1J-682JE	1	435036824R1
R1214	CHIP TYPE CARBON RESISTOR	RN72K1J-393JE	1	435033934R1
R1215	CHIP TYPE CARBON RESISTOR	RN72K1J-393JE	1	435033934R1
R1216	CHIP TYPE CARBON RESISTOR	RN72K1J-470JE	1	435034704R1
R1219	CHIP TYPE CARBON RESISTOR	RN72K1J-103JE	1	435031034R1
R1220	CHIP TYPE CARBON RESISTOR	RN72K1J-221JE	1	435032214R1
R1221	CHIP TYPE CARBON RESISTOR	RN72K1J-103JE	1	435031034R1
R1222	CHIP TYPE CARBON RESISTOR	RN72K1J-221JE	1	435032214R1
R1223	CHIP TYPE CARBON RESISTOR	RN72K1J-221JE	1	435032214R1
R1224	CHIP TYPE CARBON RESISTOR	RN72K1J-221JE	1	435032214R1
R1225	CHIP TYPE CARBON RESISTOR	RN72K1J-750JE	1	435037504R1
R1226	CHIP TYPE CARBON RESISTOR	RN72K1J-151JE	1	435031514R1
R1227	CHIP TYPE CARBON RESISTOR	RN72K1J-331JE	1	435033314R1
R1228	CHIP TYPE CARBON RESISTOR	RN72K1J-331JE	1	435033314R1
R1229	CHIP TYPE CARBON RESISTOR	RN72K1J-101JE	1	435031014R1
R1230	CHIP TYPE CARBON RESISTOR	RN72K1J-470JE	1	435034704R1
R1231	CHIP TYPE CARBON RESISTOR	RN72K1J-470JE	1	435034704R1
R1232	CHIP TYPE CARBON RESISTOR	RN72K1J-470JE	1	435034704R1
R1233	CHIP TYPE CARBON RESISTOR	RN72K1J-151JE	1	435031514R1
R1234	CHIP TYPE CARBON RESISTOR	RN72K1J-331JE	1	435033314R1
R1235	CHIP TYPE CARBON RESISTOR	RN72K1J-470JE	1	435034704R1
R1236	CHIP TYPE CARBON RESISTOR	RN72K1J-331JE	1	435033314R1
R1237	CHIP TYPE CARBON RESISTOR	RN72K1J-105JE	1	435031054R1
R1238	CHIP TYPE CARBON RESISTOR	RN72K1J-102JE	1	435031024R1
R1239	CHIP TYPE CARBON RESISTOR	RN72K1J-560JE	1	435035604R1

R1240	CHIP TYPE CARBON RESISTOR	RN72K1J-331JE	1	435033314R1
R1241	CHIP TYPE CARBON RESISTOR	RN72K1J-331JE	1	435033314R1
R1242	CHIP TYPE CARBON RESISTOR	RN72K1J-331JE	1	435033314R1
R1243	CHIP TYPE CARBON RESISTOR	RN72K1J-331JE	1	435033314R1
R1244	CHIP TYPE CARBON RESISTOR	RN72K1J-331JE	1	435033314R1
R1245	CHIP TYPE CARBON RESISTOR	RN72K1J-331JE	1	435033314R1
R1246	CHIP TYPE CARBON RESISTOR	RN72K1J-331JE	1	435033314R1
R1247	CHIP TYPE CARBON RESISTOR	RN72K1J-221JE	1	435032214R1
R1248	CHIP TYPE CARBON RESISTOR	RN72K1J-103JE	1	435031034R1
R1249	CHIP TYPE CARBON RESISTOR	RN72K1J-103JE	1	435031034R1
R1250	CHIP TYPE CARBON RESISTOR	RN72K1J-681JE	1	435036814R1
R1251	CHIP TYPE CARBON RESISTOR	RN72K1J-221JE	1	435032214R1
R1252	CHIP TYPE CARBON RESISTOR	RN72K1J-470JE	1	435034704R1
R1253	CHIP TYPE CARBON RESISTOR	RN72K1J-103JE	1	435031034R1
R1254	CHIP TYPE CARBON RESISTOR	RN72K1J-103JE	1	435031034R1
R1255	CHIP TYPE CARBON RESISTOR	RN72K1J-221JE	1	435032214R1
R1256	CHIP TYPE CARBON RESISTOR	RN72K1J-103JE	1	435031034R1
R1257	CHIP TYPE CARBON RESISTOR	RN72K1J-103JE	1	435031034R1
R1258	CHIP TYPE CARBON RESISTOR	RN72K1J-221JE	1	435032214R1
R1259	CHIP TYPE CARBON RESISTOR	RN72K1J-221JE	1	435032214R1
R1260	CHIP TYPE CARBON RESISTOR	RN72K1J-221JE	1	435032214R1
R1261	CHIP RESISTOR NETWORK	YCN104-103-JK	1	43464C10304R1
R1262	CHIP TYPE CARBON RESISTOR	RN72K1J-470JE	1	435034704R1
R1263	CHIP TYPE CARBON RESISTOR	RN72K1J-470JE	1	435034704R1
R1264	CHIP TYPE CARBON RESISTOR	RN72K1J-151JE	1	435031514R1
R1265	CHIP TYPE CARBON RESISTOR	RN72K1J-470JE	1	435034704R1
R1266	CHIP TYPE CARBON RESISTOR	RN72K1J-331JE	1	435033314R1
R1269	CHIP TYPE CARBON RESISTOR	RN72K1J-331JE	1	435033314R1
R1270	CHIP TYPE CARBON RESISTOR	RN72K1J-000JE	1	435030004R1
R1271	CHIP TYPE CARBON RESISTOR	RN72K1J-000JE	1	435030004R1
R1313	CHIP TYPE CARBON RESISTOR	RN72K1J-221JE	1	435032214R1
R1314	CHIP TYPE CARBON RESISTOR	RN72K1J-221JE	1	435032214R1
R1315	CHIP TYPE CARBON RESISTOR	RN72K1J-221JE	1	435032214R1
R1316	CHIP TYPE CARBON RESISTOR	RN72K1J-221JE	1	435032214R1
R1317	CHIP TYPE CARBON RESISTOR	RN72K1J-221JE	1	435032214R1
R1318	CHIP TYPE CARBON RESISTOR	RN72K1J-221JE	1	435032214R1
R1319	CHIP TYPE CARBON RESISTOR	RN72K1J-221JE	1	435032214R1
R1320	CHIP TYPE CARBON RESISTOR	RN72K1J-221JE	1	435032214R1
R1326	CHIP TYPE CARBON RESISTOR	RN72K1J-221JE	1	435032214R1
R1327	CHIP TYPE CARBON RESISTOR	RN72K1J-221JE	1	435032214R1
R1328	CHIP TYPE CARBON RESISTOR	RN72K1J-221JE	1	435032214R1
R1337	METAL OXIDE FILM RESISTOR	RS1/2WBJ-22	1	443522204T
R1338	METAL OXIDE FILM RESISTOR	RS1/2WBJ-22	1	443522204T
R1339	CHIP TYPE CARBON RESISTOR	RN72K1J-220JE	1	435032204R1
R1340	CHIP TYPE CARBON RESISTOR	RN72K1J-220JE	1	435032204R1
R1400	CHIP TYPE CARBON RESISTOR	RN72K1J-332JE	1	435033324R1
R1401	CHIP TYPE CARBON RESISTOR	RN72K1J-332JE	1	435033324R1
R1402	CHIP TYPE CARBON RESISTOR	RN72K1J-332JE	1	435033324R1
R1403	CHIP TYPE CARBON RESISTOR	RN72K1J-332JE	1	435033324R1
R1404	CHIP TYPE CARBON RESISTOR	RN72K1J-332JE	1	435033324R1
R1405	CHIP TYPE CARBON RESISTOR	RN72K1J-332JE	1	435033324R1
R1406	CHIP TYPE CARBON RESISTOR	RN72K1J-332JE	1	435033324R1
R1407	CHIP TYPE CARBON RESISTOR	RN72K1J-332JE	1	435033324R1
R1410	CHIP TYPE CARBON RESISTOR	RN72K1J-332JE	1	435033324R1
R1411	CHIP TYPE CARBON RESISTOR	RN72K1J-332JE	1	435033324R1
R1412	CHIP TYPE CARBON RESISTOR	RN72K1J-332JE	1	435033324R1
R1413	CHIP TYPE CARBON RESISTOR	RN72K1J-332JE	1	435033324R1
R1414	CHIP TYPE CARBON RESISTOR	RN72K1J-332JE	1	435033324R1
R1415	CHIP TYPE CARBON RESISTOR	RN72K1J-332JE	1	435033324R1
R1416	CHIP TYPE CARBON RESISTOR	RN72K1J-332JE	1	435033324R1
R1417	CHIP TYPE CARBON RESISTOR	RN72K1J-332JE	1	435033324R1
R1420	CHIP TYPE CARBON RESISTOR	RN72K1J-332JE	1	435033324R1

R1421	CHIP TYPE CARBON RESISTOR	RN72K1J-332JE	1	435033324R1
R1422	CHIP TYPE CARBON RESISTOR	RN72K1J-332JE	1	435033324R1
R1423	CHIP TYPE CARBON RESISTOR	RN72K1J-332JE	1	435033324R1
R1424	CHIP TYPE CARBON RESISTOR	RN72K1J-332JE	1	435033324R1
R1425	CHIP TYPE CARBON RESISTOR	RN72K1J-332JE	1	435033324R1
R1426	CHIP TYPE CARBON RESISTOR	RN72K1J-332JE	1	435033324R1
R1427	CHIP TYPE CARBON RESISTOR	RN72K1J-332JE	1	435033324R1
R1430	CHIP TYPE CARBON RESISTOR	RN72K1J-332JE	1	435033324R1
R1431	CHIP TYPE CARBON RESISTOR	RN72K1J-332JE	1	435033324R1
R1432	CHIP TYPE CARBON RESISTOR	RN72K1J-332JE	1	435033324R1
R1433	CHIP TYPE CARBON RESISTOR	RN72K1J-332JE	1	435033324R1
R1434	CHIP TYPE CARBON RESISTOR	RN72K1J-332JE	1	435033324R1
R1435	CHIP TYPE CARBON RESISTOR	RN72K1J-332JE	1	435033324R1
R1436	CHIP TYPE CARBON RESISTOR	RN72K1J-332JE	1	435033324R1
R1437	CHIP TYPE CARBON RESISTOR	RN72K1J-332JE	1	435033324R1
R1440	CHIP TYPE CARBON RESISTOR	RN72K1J-151JE	1	435031514R1
R1441	CHIP TYPE CARBON RESISTOR	RN72K1J-151JE	1	435031514R1
R1442	CHIP TYPE CARBON RESISTOR	RN72K1J-151JE	1	435031514R1
R1443	CHIP TYPE CARBON RESISTOR	RN72K1J-151JE	1	435031514R1
R1444	CHIP TYPE CARBON RESISTOR	RN72K1J-151JE	1	435031514R1
R1445	CHIP TYPE CARBON RESISTOR	RN72K1J-151JE	1	435031514R1
R1446	CHIP TYPE CARBON RESISTOR	RN72K1J-151JE	1	435031514R1
R1447	CHIP TYPE CARBON RESISTOR	RN72K1J-151JE	1	435031514R1
R1450	CHIP TYPE CARBON RESISTOR	RN72K1J-151JE	1	435031514R1
R1451	CHIP TYPE CARBON RESISTOR	RN72K1J-151JE	1	435031514R1
R1452	CHIP TYPE CARBON RESISTOR	RN72K1J-151JE	1	435031514R1
R1453	CHIP TYPE CARBON RESISTOR	RN72K1J-151JE	1	435031514R1
R1454	CHIP TYPE CARBON RESISTOR	RN72K1J-151JE	1	435031514R1
R1455	CHIP TYPE CARBON RESISTOR	RN72K1J-151JE	1	435031514R1
R1456	CHIP TYPE CARBON RESISTOR	RN72K1J-151JE	1	435031514R1
R1457	CHIP TYPE CARBON RESISTOR	RN72K1J-151JE	1	435031514R1
R1460	CHIP TYPE CARBON RESISTOR	RN72K1J-472JE	1	435034724R1
R1461	CHIP TYPE CARBON RESISTOR	RN72K1J-472JE	1	435034724R1
R1470	CHIP TYPE CARBON RESISTOR	RN72K1J-222JE	1	435032224R1
R1471	CHIP TYPE CARBON RESISTOR	RN72K1J-222JE	1	435032224R1
R1480	CHIP TYPE CARBON RESISTOR	RN72K1J-472JE	1	435034724R1
R1481	CHIP TYPE CARBON RESISTOR	RN72K1J-472JE	1	435034724R1
R1490	CHIP TYPE CARBON RESISTOR	RN72K1J-472JE	1	435034724R1
R1491	CHIP TYPE CARBON RESISTOR	RN72K1J-472JE	1	435034724R1
R1500	CHIP TYPE CARBON RESISTOR	RN72K1J-472JE	1	435034724R1
R1501	CHIP TYPE CARBON RESISTOR	RN72K1J-472JE	1	435034724R1
R1510	CHIP TYPE CARBON RESISTOR	RN72K1J-681JE	1	435036814R1
R1511	CHIP TYPE CARBON RESISTOR	RN72K1J-681JE	1	435036814R1
R1520	CHIP TYPE CARBON RESISTOR	RN72K1J-102JE	1	435031024R1
R1521	CHIP TYPE CARBON RESISTOR	RN72K1J-102JE	1	435031024R1
R1530	CHIP TYPE CARBON RESISTOR	RN72K1J-152JE	1	435031524R1
R1531	CHIP TYPE CARBON RESISTOR	RN72K1J-152JE	1	435031524R1
R1540	CHIP TYPE CARBON RESISTOR	RN72K1J-682JE	1	435036824R1
R1541	CHIP TYPE CARBON RESISTOR	RN72K1J-682JE	1	435036824R1
R1550	CHIP TYPE CARBON RESISTOR	RN72K1J-152JE	1	435031524R1
R1551	CHIP TYPE CARBON RESISTOR	RN72K1J-152JE	1	435031524R1
R1560	CHIP TYPE CARBON RESISTOR	RN72K1J-331JE	1	435033314R1
R1561	CHIP TYPE CARBON RESISTOR	RN72K1J-331JE	1	435033314R1
R1570	CHIP TYPE CARBON RESISTOR	RN72K1J-331JE	1	435033314R1
R1571	CHIP TYPE CARBON RESISTOR	RN72K1J-331JE	1	435033314R1

**[SW TRM]**

P1000	TRM-423(SCREW)	NEJITANSI ST3	1	25060495
P1001	ST JACK	MSJ-035-22	1	25045887
P1002	PIN JACK	NPJ-2PDO666	1	25045895
P1003	TRM-423(SCREW)	NEJITANSI ST3	1	25060495
P1004	TRM-423(SCREW)	NEJITANSI ST3	1	25060495
P1008B	PLUG	IMSA-9142B-24A	1	25056602

P8002B	SOCKET(B to B)	IMSA-9850S-24Y	1	25052815R2	
P8003B	SOCKET(B to B)	IMSA-9850S-24Y	1	25052815R2	
<b>[TUNER UNIT]</b>					
U1000	PHOTO COUPLER	JSR1165-001recieving	1	24120143	
U1001	PHOTO COUPLER	JSR1165-001recieving	1	24120143	
U1002	PHOTO COUPLER	JSR1165-001recieving	1	24120143	
<b>U003</b> BADIS-1816-1C : NSP					
<b>CIRCUIT NO</b>	<b>PART NAME</b>	<b>DESCRIPTION</b>	<b>Q'TY</b>	<b>PART NO. (SN)</b>	<b>REMARKS</b>
<b>[SEMI CONDUCTOR]</b>					
D7500	ZENER DIODE	DZ2J082M0L	1	224760820R2	
D7500 or	ZENER DIODE	UDZS8.2B	( 1)	224550820R2	
D7501	ZENER DIODE	DZ2J039M0L	1	224760390R2	
D7501 or	ZENER DIODE	UDZS3.9B	( 1)	224550390R2	
D7530	ZENER DIODE	DZ2J051M0L	1	224760510R2	
D7533	ZENER DIODE	DZ2J068M0L	1	224760680R2	
D7534	ZENER DIODE	DZ2J068M0L	1	224760680R2	
D7594	LED	SCB3318E-D2	1	225487	
D7595	LED	HLMP-Y701	1	225528	
D7596	LED	HLMP-Y701	1	225528	
Q1	HYBRID IC	RZ5B801-0001E2	1	22242835R2	
Q7505	TRANSISTOR	KTC3875-GR	1	2216175R2	
Q7511	TRANSISTOR	KRC107S	1	2216340R2	
Q7512	TRANSISTOR	KTA1661-Y	1	2217864R2	
Q7520	HYBRID IC	BU2090F-E2	1	22242686R2	
Q7530	HYBRID IC	NJM4580CG	1	22242922R2	
Q7532	TRANSISTOR	RTAN430C-T112-1	1	2217780R2	
Q7533	TRANSISTOR	RN2403	1	2214540R2	
Q7533 or	TRANSISTOR	KRA103S	( 1)	2216230R2	
Q7560	REMOTE SENSOR	IRM-3638M3S28	1	24130026	
Q7650	FLUORESCENT TUBE	16-BT-165GINK	1	212276	
Q7650A	HOLDER	(FL)	1	27191370	
Q7650Aor	HOLDER	(FL)	( 1)	27191303	
Q7651	TRANSISTOR	2SC2712-GR	1	2213145R2	
Q7651 or	TRANSISTOR	KTC3875-GR	( 1)	2216175R2	
Q7652	TRANSISTOR	2SC2712-GR	1	2213145R2	
Q7652 or	TRANSISTOR	KTC3875-GR	( 1)	2216175R2	
<b>[TRANS COIL]</b>					
L1	CHIP TYPE CARBON RESISTOR	RN72K1J-000JE	1	435030004R1	
L2	CHIP TYPE CARBON RESISTOR	RN72K1J-000JE	1	435030004R1	
L3	RF COIL	SDCL1608CR33JTDF	1	233557R1	
L3 or	RF COIL	HK1608R33J-T	( 1)	233559R1	
L4	RF COIL	SDCL1608CR10JTDF	1	233556R1	
L4 or	RF COIL	HK1608R10J-T	( 1)	233558R1	
L5	ANTENNA COIL	K7-D	1	232212	
L7505	CHOKE COIL	LBC2518T2R2M	1	231364M022R2	
L7506	CHOKE COIL	LBC2518T2R2M	1	231364M022R2	
L7530	CHOKE COIL	LBC2518T2R2M	1	231364M022R2	
L7580	CHOKE COIL	LBC2518T2R2M	1	231364M022R2	
L7581	CHOKE COIL	LBC2518T2R2M	1	231364M022R2	
L7582	CHOKE COIL	LBC2518T2R2M	1	231364M022R2	
X1	CRYSTAL	HC-49S 9B12.000MHz	1	3010533	
<b>[CAPACITOR]</b>					
C1	CHIP TYPE CERAMIC CAPACITOR	CC725CH1H-101J1	1	342101014R1	
C12	CHIP TYPE CERAMIC CAPACITOR	CC725CH1H-090D1	1	342100902R1	
C13	CHIP TYPE CERAMIC CAPACITOR	CK725B1C-104K1	1	332121045R1	
C2	CHIP TYPE CERAMIC CAPACITOR	CC725CH1H-220J1	1	342102204R1	
C3	CHIP TYPE CERAMIC CAPACITOR	CK725B1H-332K1	1	332103325R1	

C4	CHIP TYPE CERAMIC CAPACITOR	CC725CH1H-100D1	1	342101002R1
C5	CHIP TYPE CERAMIC CAPACITOR	CK725B1H-473K1	1	332104735R1
C6	CHIP TYPE CERAMIC CAPACITOR	CK725B1H-222K1	1	332102225R1
C7	CHIP TYPE CERAMIC CAPACITOR	CK725B1A-105K1	1	332131055R1
C7500	CHIP TYPE CERAMIC CAPACITOR	CK725B1H-223K1	1	332102235R1
C7501	CHIP TYPE CERAMIC CAPACITOR	CK725B1H-223K1	1	332102235R1
C7502	CHIP TYPE CERAMIC CAPACITOR	CK725B1H-223K1	1	332102235R1
C7503	CHIP TYPE CERAMIC CAPACITOR	CK725B1H-223K1	1	332102235R1
C7504	CHIP TYPE CERAMIC CAPACITOR	CK725B1H-223K1	1	332102235R1
C7506	ELECTROLYTIC CAPACITOR	CE04W16V-47M(S)	1	353744709T
C7508	ELECTROLYTIC CAPACITOR	CE04W6.3V-100M(S)	1	353721019T
C7509	ELECTROLYTIC CAPACITOR	CE04W16V-10M(S)	1	353741009T
C7511	CHIP TYPE CERAMIC CAPACITOR	CC725CH1H-101J1	1	342101014R1
C7512	CHIP TYPE CERAMIC CAPACITOR	CC725CH1H-101J1	1	342101014R1
C7513	CHIP TYPE CERAMIC CAPACITOR	CC725CH1H-101J1	1	342101014R1
C7514	CHIP TYPE CERAMIC CAPACITOR	CC725CH1H-101J1	1	342101014R1
C7520	CHIP TYPE CERAMIC CAPACITOR	CK725B1H-102K1	1	332101025R1
C7522	CHIP TYPE CERAMIC CAPACITOR	CK725F1A-105Z1	1	332181050R1
C7525	CHIP TYPE CERAMIC CAPACITOR	CC725CH1H-101J1	1	342101014R1
C7526	CHIP TYPE CERAMIC CAPACITOR	CC725CH1H-101J1	1	342101014R1
C7530	CHIP TYPE CERAMIC CAPACITOR	CK725B1H-102K1	1	332101025R1
C7531	CHIP TYPE CERAMIC CAPACITOR	CK725B1H-102K1	1	332101025R1
C7532	CHIP TYPE CERAMIC CAPACITOR	CC725CH1H-101J1	1	342101014R1
C7533	ELECTROLYTIC CAPACITOR	CE04W16V-47M(S)	1	353744709T
C7534	ELECTROLYTIC CAPACITOR	CE04W16V-47M(S)	1	353744709T
C7535	ELECTROLYTIC CAPACITOR	CE04W35V-10M(S)	1	353761009T
C7536	ELECTROLYTIC CAPACITOR	CE04W16V-47M(S)	1	353744709T
C7537	CHIP TYPE CERAMIC CAPACITOR	CC725CH1H-330J1	1	342103304R1
C7538	ELECTROLYTIC CAPACITOR	CE04W35V-10M(S)	1	353761009T
C7543	CHIP TYPE CERAMIC CAPACITOR	CK725F1E-104Z1	1	332161040R1
C7544	CHIP TYPE CERAMIC CAPACITOR	CK725F1E-104Z1	1	332161040R1
C7560	ELECTROLYTIC CAPACITOR	CE04W16V-10M(S)	1	353741009T
C7562	CHIP TYPE CERAMIC CAPACITOR	CK725B1H-102K1	1	332101025R1
C7563	CHIP TYPE CERAMIC CAPACITOR	CK725B1H-103K1	1	332101035R1
C7564	CHIP TYPE CERAMIC CAPACITOR	CK725B1H-103K1	1	332101035R1
C7580	CHIP TYPE CERAMIC CAPACITOR	CC725CH1H-102J1	1	342101024R1
C7581	UMXR TYPE PLASTIC FILM CAPACITOR	1JUMXRTF102JE	1	376591024T
C7582	UMXR TYPE PLASTIC FILM CAPACITOR	1JUMXRTF102JE	1	376591024T
C7583	CHIP TYPE CERAMIC CAPACITOR	CC725CH1H-102J1	1	342101024R1
C7651	CHIP TYPE CERAMIC CAPACITOR	CK725B1H-473K1	1	332104735R1
C7652	CHIP TYPE CERAMIC CAPACITOR	CK725F1H-104Z1	1	332151040R1
C7653	CHIP TYPE CERAMIC CAPACITOR	CK725F1E-104Z1	1	332161040R1
C8	CHIP TYPE CERAMIC CAPACITOR	CK725B1A-105K1	1	332131055R1
C9	CHIP TYPE CERAMIC CAPACITOR	CK732B16V-106K	1	332071065R2
<b>[RESISTOR]</b>				
R10	CHIP TYPE CARBON RESISTOR	RN72K1J-000JE	1	435030004R1
R11	CHIP TYPE CARBON RESISTOR	RN72K1J-000JE	1	435030004R1
R13	CHIP TYPE CARBON RESISTOR	RN72K1J-000JE	1	435030004R1
R14	CHIP TYPE CARBON RESISTOR	RN72K1J-000JE	1	435030004R1
R2	CHIP TYPE CARBON RESISTOR	RN72K1J-101JE	1	435031014R1
R21	CHIP TYPE CARBON RESISTOR	RN72K2E-000JE	1	435220004R1
R22	CHIP TYPE CARBON RESISTOR	RN72K2E-000JE	1	435220004R1
R3	EMI SUPPRESSION FILTER	BK1608HS601-T	1	230984R1
R4	EMI SUPPRESSION FILTER	BK1608HS601-T	1	230984R1
R5	CHIP TYPE CARBON RESISTOR	RN72K1J-103JE	1	435031034R1
R6	CHIP TYPE CARBON RESISTOR	RN72K1J-472JE	1	435034724R1
R7	CHIP TYPE CARBON RESISTOR	RN72K1J-472JE	1	435034724R1
R7500	CHIP TYPE CARBON RESISTOR	RN72K2E-221JE	1	435222214R1
R7501	CHIP TYPE CARBON RESISTOR	RN72K2E-221JE	1	435222214R1
R7505	CHIP TYPE CARBON RESISTOR	RN72K1J-221JE	1	435032214R1
R7515	CHIP TYPE CARBON RESISTOR	RN72K1J-473JE	1	435034734R1
R7516	CHIP TYPE CARBON RESISTOR	RN72K1J-103JE	1	435031034R1

R7517	CHIP TYPE CARBON RESISTOR	RN72K1J-103JE	1	435031034R1
R7520	CHIP TYPE CARBON RESISTOR	RN72K1J-331JE	1	435033314R1
R7521	CHIP TYPE CARBON RESISTOR	RN72K1J-331JE	1	435033314R1
R7530	CHIP TYPE CARBON RESISTOR	RN72K1J-101JE	1	435031014R1
R7531	CHIP TYPE CARBON RESISTOR	RN72K1J-331JE	1	435033314R1
R7532	CHIP TYPE CARBON RESISTOR	RN72K1J-821JE	1	435038214R1
R7533	CHIP TYPE CARBON RESISTOR	RN72K1J-472JE	1	435034724R1
R7534	CHIP TYPE CARBON RESISTOR	RN72K1J-104JE	1	435031044R1
R7535	CHIP TYPE CARBON RESISTOR	RN72K1J-102JE	1	435031024R1
R7536	CHIP TYPE CARBON RESISTOR	RN72K1J-333JE	1	435033334R1
R7537	CHIP TYPE CARBON RESISTOR	RN72K1J-333JE	1	435033334R1
R7538	CHIP TYPE CARBON RESISTOR	RN72K1J-471JE	1	435034714R1
R7540	CHIP TYPE CARBON RESISTOR	RN72K1J-473JE	1	435034734R1
R7545	CHIP TYPE CARBON RESISTOR	RN72K1J-221JE	1	435032214R1
R7546	CHIP TYPE CARBON RESISTOR	RN72K1J-221JE	1	435032214R1
R7556	CHIP TYPE CARBON RESISTOR	RN72K1J-181JE	1	435031814R1
R7557	CHIP TYPE CARBON RESISTOR	RN72K1J-181JE	1	435031814R1
R7560	CHIP TYPE CARBON RESISTOR	RN72K1J-222JE	1	435032224R1
R7561	CHIP TYPE CARBON RESISTOR	RN72K1J-101JE	1	435031014R1
R7563	CHIP TYPE CARBON RESISTOR	RN72K1J-103JE	1	435031034R1
R7564	CHIP TYPE CARBON RESISTOR	RN72K1J-103JE	1	435031034R1
R7565	CHIP TYPE CARBON RESISTOR	RN72K1J-103JE	1	435031034R1
R7566	CHIP TYPE CARBON RESISTOR	RN72K1J-103JE	1	435031034R1
R7573	CHIP TYPE CARBON RESISTOR	RN72K1J-102JE	1	435031024R1
R7580	METAL OXIDE FILM RESISTOR	RS1/2WBJ-33	1	443523304T
R7581	METAL OXIDE FILM RESISTOR	RS1/2WBJ-33	1	443523304T
R7594	CHIP TYPE CARBON RESISTOR	RN72K1J-392JE	1	435033924R1
R7595	CHIP TYPE CARBON RESISTOR	RN72K1J-102JE	1	435031024R1
R7611	CHIP TYPE CARBON RESISTOR	RN72K1J-271JE	1	435032714R1
R7612	CHIP TYPE CARBON RESISTOR	RN72K1J-331JE	1	435033314R1
R7613	CHIP TYPE CARBON RESISTOR	RN72K1J-471JE	1	435034714R1
R7614	CHIP TYPE CARBON RESISTOR	RN72K1J-561JE	1	435035614R1
R7615	CHIP TYPE CARBON RESISTOR	RN72K1J-821JE	1	435038214R1
R7616	CHIP TYPE CARBON RESISTOR	RN72K1J-122JE	1	435031224R1
R7617	CHIP TYPE CARBON RESISTOR	RN72K1J-222JE	1	435032224R1
R7618	CHIP TYPE CARBON RESISTOR	RN72K1J-392JE	1	435033924R1
R7619	CHIP TYPE CARBON RESISTOR	RN72K1J-123JE	1	435031234R1
R7621	CHIP TYPE CARBON RESISTOR	RN72K1J-271JE	1	435032714R1
R7622	CHIP TYPE CARBON RESISTOR	RN72K1J-331JE	1	435033314R1
R7623	CHIP TYPE CARBON RESISTOR	RN72K1J-471JE	1	435034714R1
R7624	CHIP TYPE CARBON RESISTOR	RN72K1J-561JE	1	435035614R1
R7625	CHIP TYPE CARBON RESISTOR	RN72K1J-821JE	1	435038214R1
R7626	CHIP TYPE CARBON RESISTOR	RN72K1J-122JE	1	435031224R1
R7627	CHIP TYPE CARBON RESISTOR	RN72K1J-222JE	1	435032224R1
R7628	CHIP TYPE CARBON RESISTOR	RN72K1J-392JE	1	435033924R1
R7629	CHIP TYPE CARBON RESISTOR	RN72K1J-123JE	1	435031234R1
R7631	CHIP TYPE CARBON RESISTOR	RN72K1J-271JE	1	435032714R1
R7632	CHIP TYPE CARBON RESISTOR	RN72K1J-331JE	1	435033314R1
R7633	CHIP TYPE CARBON RESISTOR	RN72K1J-471JE	1	435034714R1
R7634	CHIP TYPE CARBON RESISTOR	RN72K1J-561JE	1	435035614R1
R7635	CHIP TYPE CARBON RESISTOR	RN72K1J-821JE	1	435038214R1
R7636	CHIP TYPE CARBON RESISTOR	RN72K1J-122JE	1	435031224R1
R7637	CHIP TYPE CARBON RESISTOR	RN72K1J-222JE	1	435032224R1
R7638	CHIP TYPE CARBON RESISTOR	RN72K1J-392JE	1	435033924R1
R7639	CHIP TYPE CARBON RESISTOR	RN72K1J-123JE	1	435031234R1
R7641	CHIP TYPE CARBON RESISTOR	RN72K1J-271JE	1	435032714R1
R7642	CHIP TYPE CARBON RESISTOR	RN72K1J-331JE	1	435033314R1
R7643	CHIP TYPE CARBON RESISTOR	RN72K1J-471JE	1	435034714R1
R7644	CHIP TYPE CARBON RESISTOR	RN72K1J-561JE	1	435035614R1
R7645	CHIP TYPE CARBON RESISTOR	RN72K1J-821JE	1	435038214R1
R7646	CHIP TYPE CARBON RESISTOR	RN72K1J-122JE	1	435031224R1
R7647	CHIP TYPE CARBON RESISTOR	RN72K1J-222JE	1	435032224R1

R7648	CHIP TYPE CARBON RESISTOR	RN72K1J-392JE	1	435033924R1
R7651	CHIP TYPE CARBON RESISTOR	RN72K1J-224JE	1	435032244R1
R7653	CHIP TYPE CARBON RESISTOR	RN72K1J-101JE	1	435031014R1
R7654	CHIP TYPE CARBON RESISTOR	RN72K1J-101JE	1	435031014R1
R7655	CHIP TYPE CARBON RESISTOR	RN72K1J-333JE	1	435033334R1
R7656	CHIP TYPE CARBON RESISTOR	RN72K1J-333JE	1	435033334R1
R7657	CHIP TYPE CARBON RESISTOR	RN72K1J-104JE	1	435031044R1
R7658	CHIP TYPE CARBON RESISTOR	RN72K1J-104JE	1	435031044R1
R7659	CHIP TYPE CARBON RESISTOR	RN72K1J-333JE	1	435033334R1
R7660	NON-FLAMMABLE CARBON FILM RESISTOR	R25J-10	1	415471004T
R7661	NON-FLAMMABLE CARBON FILM RESISTOR	R25J-10	1	415471004T
R7662	CHIP TYPE CARBON RESISTOR	RN72K1J-221JE	1	435032214R1
R7663	CHIP TYPE CARBON RESISTOR	RN72K1J-221JE	1	435032214R1
R7664	CHIP TYPE CARBON RESISTOR	RN72K1J-332JE	1	435033324R1
R7666	CHIP TYPE CARBON RESISTOR	RN72K1J-332JE	1	435033324R1
R8	CHIP TYPE CARBON RESISTOR	RN72K1J-101JE	1	435031014R1
R9	CHIP TYPE CARBON RESISTOR	RN72K1J-101JE	1	435031014R1
<b>[SW TRM]</b>				
P1	TERMINAL	NTM-1PDSC437	1	25060515
P101A	SOCKET	NSCT-7P2100	1	25052203
P2	TERMINAL	NTM-2PDML439	1	25060517
P6605B	PLUG	NPLG-5P119	1	25055135
P7002B	SOCKET	NSCT-27P2445	1	25052548
P7530	ST JACK	MSJ-035-05C B AG GR type	1	25045880
P7562A	WIRE HOL	NSCT-3P874	1	25051087
P7562Aor	WIRE HOL	CHD-1.5-3	(1)	25053535
P7562B	WIRE HOL	NSCT-3P874	1	25051087
P7562Bor	WIRE HOL	CHD-1.5-3	(1)	25053535
P7580	ST JACK	MSJ-064-05A GR	1	25045782
P7581	TERMINAL	NTM-1P233(M1969)	1	25060302
P7590	WIRE HARNESS ASSEMBLY	NSAS-3P2092	1	2009991281UL
P7590A	WIRE HOL	NSCT-3P874	1	25051087
P7590Aor	WIRE HOL	CHD-1.5-3	(1)	25053535
P7590B	PLUG	NPLG-3P350	1	25055367
P7591	WIRE HARNESS ASSEMBLY	NSAS-9P2140	1	2009991329UL
P7591A	WIRE HOL	NSCT-9P880	1	25051093
P7591Aor	WIRE HOL	CHD-1.5-9	(1)	25053538
P7591B	PLUG	NPLG-9P356	1	25055373
P7592A	WIRE HOL	NSCT-5P876	1	25051089
P7592Aor	WIRE HOL	CHD-1.5-5	(1)	25053536
P7592B	WIRE HOL	NSCT-5P876	1	25051089
P7592Bor	WIRE HOL	CHD-1.5-5	(1)	25053536
P9303	WIRE HARNESS ASSEMBLY	NSAS-9P2147	1	2009991336UL
P9303A	WIRE HOL	NSCT-9P880	1	25051093
P9303Aor	WIRE HOL	CHD-1.5-9	(1)	25053538
S7561	ROTARY ENCODER	EVEHD1F3024B	1	25065695W
S7611	PUSH SWITCH	NPS-111-S681	1	25035718T
S7611 or	PUSH SWITCH	NPS-111-S677	(1)	25035714T
S7613	PUSH SWITCH	NPS-111-S681	1	25035718T
S7613 or	PUSH SWITCH	NPS-111-S677	(1)	25035714T
S7614	PUSH SWITCH	NPS-111-S681	1	25035718T
S7614 or	PUSH SWITCH	NPS-111-S677	(1)	25035714T
S7616	PUSH SWITCH	NPS-111-S681	1	25035718T
S7616 or	PUSH SWITCH	NPS-111-S677	(1)	25035714T
S7617	PUSH SWITCH	NPS-111-S681	1	25035718T
S7617 or	PUSH SWITCH	NPS-111-S677	(1)	25035714T
S7618	PUSH SWITCH	NPS-111-S681	1	25035718T
S7618 or	PUSH SWITCH	NPS-111-S677	(1)	25035714T
S7619	PUSH SWITCH	NPS-111-S681	1	25035718T
S7619 or	PUSH SWITCH	NPS-111-S677	(1)	25035714T
S7620	PUSH SWITCH	NPS-111-S681	1	25035718T
S7620 or	PUSH SWITCH	NPS-111-S677	(1)	25035714T







U004

BAPRC-1802-1E

: NSP

CIRCUIT NO	PART NAME	DESCRIPTION	Q'TY	PART NO. (SN)	REMARKS
<b>[SEMI CONDUCTOR]</b>					
D3402	CHIP TYPE DIODE	DA2J10100	1	223303R2	
D3402 or	CHIP TYPE DIODE	1SS352	(1)	223234R2	
D7001	CHIP TYPE DIODE	DA2J10100	1	223303R2	
D7001 or	CHIP TYPE DIODE	1SS352	(1)	223234R2	
D7002	CHIP TYPE DIODE	DA2J10100	1	223303R2	
D7002 or	CHIP TYPE DIODE	1SS352	(1)	223234R2	
D7003	CHIP TYPE DIODE	DA2J10100	1	223303R2	
D7003 or	CHIP TYPE DIODE	1SS352	(1)	223234R2	
D7004	CHIP TYPE DIODE	DA2J10100	1	223303R2	
D7006	CHIP TYPE DIODE	DA2J10100	1	223303R2	
D7006 or	CHIP TYPE DIODE	1SS352	(1)	223234R2	
D7009	CHIP TYPE DIODE	DA2J10100	1	223303R2	
D7009 or	CHIP TYPE DIODE	1SS352	(1)	223234R2	
D7012	DIODE	RB050M-30GTR	1	22380373R2	
D7013	DIODE	RB050M-30GTR	1	22380373R2	
D8003	ESD	IMSA-6802-01Y901_1608SIZE	1	4000255AR1	
D8301	ZENER DIODE	DZ2J036M0L	1	224760360R2	
D8301 or	ZENER DIODE	UDZS3.6B	(1)	224550360R2	
D8400	CHIP TYPE DIODE	DA2J10100	1	223303R2	
D8400 or	CHIP TYPE DIODE	1SS352	(1)	223234R2	
D8900	DIODE	CUS357	1	223320R2	
D8901	DIODE	CUS357	1	223320R2	
D8902	DIODE	CUS357	1	223320R2	
D8907	CHIP TYPE DIODE	DA2J10100	1	223303R2	
D8907 or	CHIP TYPE DIODE	1SS352	(1)	223234R2	
D8909	CHIP TYPE DIODE	DA2J10100	1	223303R2	
D8909 or	CHIP TYPE DIODE	1SS352	(1)	223234R2	
D8942	CHIP TYPE DIODE	DA2J10100	1	223303R2	
D8942 or	CHIP TYPE DIODE	1SS352	(1)	223234R2	
D8943	CHIP TYPE DIODE	DA2J10100	1	223303R2	
D8943 or	CHIP TYPE DIODE	1SS352	(1)	223234R2	
D8963	DIODE	RB050M-30GTR	1	22380373R2	
Q1900	HYBRID IC	PCM5101APWR	1	22242855R2	
Q1901	HYBRID IC	74VHC4040FT	1	22274040E1R2TO	
Q1902	HYBRID IC	TC7WH241FU(TE12L_F)	1	22242076R2TO	
Q1903	HYBRID IC	PCM5101APWR	1	22242855R2	
Q1904	HYBRID IC	S-1333A33-M5T1U3	1	22242934R2	
Q3001	HYBRID IC	D830K013DZKB400	1	22242851R3	
Q3002	HYBRID IC	TC58DVM92A5TA10B3H	1	222W0125R3	firmware
Q3003	HYBRID IC	A3V56S40GTP-60RX	1	22242891R2	
Q3004	HYBRID IC	A3V56S40GTP-60RX	1	22242891R2	
Q3005	HYBRID IC	TC7W32FU	1	22241162R2	
Q3006	HYBRID IC	PST803C270NM	1	22242894R2	
Q3100	TRANSISTOR	KRA302E	1	2218360R2	N
Q3100 or	TRANSISTOR	RN2102	(1)	2218270R2	
Q3102	TRANSISTOR	KRC402E	1	2218330R2	N
Q3102 or	TRANSISTOR	RN1102	(1)	2218230R2	
Q3103	HYBRID IC	S-1333A18-M5T1U3	1	22242956R2	
Q3105	HYBRID IC	MFI337S3959	1	22242820R2	
Q3108	HYBRID IC	KSZ8081RNBCA	1	22242921R2	
Q3109	HYBRID IC	S-13A1A12-U5T1U3	1	22242841R2	
Q3121	HYBRID IC	FP6861C-B1AS5CT	1	22242840R2	
Q3200	HYBRID IC	74VHC541FT	1	22274541E1R2TO	
Q3201	TRANSISTOR	KRC402E	1	2218330R2	N
Q3201 or	TRANSISTOR	RN1102	(1)	2218230R2	
Q3202	HYBRID IC	74LCX125FT	1	22274125BR2TO	
Q3203	TRANSISTOR	KRC402E	1	2218330R2	N
Q3203 or	TRANSISTOR	RN1102	(1)	2218230R2	

Q3401	HYBRID IC	S25FL164K0XMF1013	1	22242955R2	N
Q3403	HYBRID IC	TC7SZU04FU	1	22242512R2TO	
Q3404	HYBRID IC	CS49844A-CQZ	1	22242926R3	
Q3406	HYBRID IC	M12L64164A-7TG2Y	1	22242951R3	
Q3410	TRANSISTOR	KRC402E	1	2218330R2	N
Q3410 or	TRANSISTOR	RN1102	(1)	2218230R2	
Q7000	TRANSISTOR	KRA302E	1	2218360R2	N
Q7000 or	TRANSISTOR	RN2102	(1)	2218270R2	
Q7001	HYBRID IC	M95640-WMN6TP	1	22242643R2	
Q7001 or	HYBRID IC	BR25S640FJ	(1)	22242761R2	
Q7002	TRANSISTOR	KRA302E	1	2218360R2	N
Q7002 or	TRANSISTOR	RN2102	(1)	2218270R2	
Q7003	TRANSISTOR	KRA302E	1	2218360R2	N
Q7003 or	TRANSISTOR	RN2102	(1)	2218270R2	
Q7004	TRANSISTOR	KRA302E	1	2218360R2	N
Q7004 or	TRANSISTOR	RN2102	(1)	2218270R2	
Q7005	TRANSISTOR	KRC404E	1	2216450R2	
Q7005 or	TRANSISTOR	RN1104	(1)	2218240R2	
Q7006	TRANSISTOR	KRC404E	1	2216450R2	
Q7006 or	TRANSISTOR	RN1104	(1)	2218240R2	
Q7007	TRANSISTOR	KRC404E	1	2216450R2	
Q7007 or	TRANSISTOR	RN1104	(1)	2218240R2	
Q7008	TRANSISTOR	KRA302E	1	2218360R2	N
Q7008 or	TRANSISTOR	RN2102	(1)	2218270R2	
Q7009	HYBRID IC	MPD70F3477AGJA-GAE-G	1	222W0117R3	firmware
Q7010	TRANSISTOR	KRC404E	1	2216450R2	
Q7010 or	TRANSISTOR	RN1104	(1)	2218240R2	
Q7011	TRANSISTOR	KRA307E	1	2218380R2	N
Q7011 or	TRANSISTOR	RN2107	(1)	2218290R2	
Q7012	TRANSISTOR	KRA307E	1	2218380R2	N
Q7012 or	TRANSISTOR	RN2107	(1)	2218290R2	
Q7013	HYBRID IC	TC7WBL3305CFK	1	22242965R2	
Q7014	TRANSISTOR	KRC402E	1	2218330R2	N
Q7014 or	TRANSISTOR	RN1102	(1)	2218230R2	
Q7015	TRANSISTOR	KRC402E	1	2218330R2	N
Q7015 or	TRANSISTOR	RN1102	(1)	2218230R2	
Q7016	TRANSISTOR	2SC2712-GR	1	2213145R2	
Q7017	TRANSISTOR	KRC402E	1	2218330R2	N
Q7017 or	TRANSISTOR	RN1102	(1)	2218230R2	
Q7018	HYBRID IC	S-1333A33-M5T1U3	1	22242934R2	
Q7019	TRANSISTOR	KRC404E	1	2216450R2	
Q7019 or	TRANSISTOR	RN1104	(1)	2218240R2	
Q7020	HYBRID IC	PST803C270NM	1	22242894R2	
Q7021	TRANSISTOR	KRA302E	1	2218360R2	N
Q7021 or	TRANSISTOR	RN2102	(1)	2218270R2	
Q7023	TRANSISTOR	KRC404E	1	2216450R2	
Q7023 or	TRANSISTOR	RN1104	(1)	2218240R2	
Q7024	TRANSISTOR	KRC404E	1	2216450R2	
Q7024 or	TRANSISTOR	RN1104	(1)	2218240R2	
Q7027	HYBRID IC	S-1333A33-M5T1U3	1	22242934R2	
Q8000	HYBRID IC	MN864788	1	22242929R3	
Q8001	TRANSISTOR	KRC402E	1	2218330R2	N
Q8001 or	TRANSISTOR	RN1102	(1)	2218230R2	
Q8002	TRANSISTOR	KRC402E	1	2218330R2	N
Q8002 or	TRANSISTOR	RN1102	(1)	2218230R2	
Q8003	HYBRID IC	74LCX125FT	1	22274125BR2TO	
Q8004	TRANSISTOR	2SA1162-GR	1	2214375R2	
Q8005	TRANSISTOR	KRC404E	1	2216450R2	
Q8005 or	TRANSISTOR	RN1104	(1)	2218240R2	
Q8006	TRANSISTOR	KRC402E	1	2218330R2	N
Q8006 or	TRANSISTOR	RN1102	(1)	2218230R2	
Q8007	TRANSISTOR	KRC402E	1	2218330R2	N

Q8007 or	TRANSISTOR	RN1102	( 1)	2218230R2	
Q8008	TRANSISTOR	KRC402E	1	2218330R2	N
Q8008 or	TRANSISTOR	RN1102	( 1)	2218230R2	
Q8009	TRANSISTOR	KRC402E	1	2218330R2	N
Q8009 or	TRANSISTOR	RN1102	( 1)	2218230R2	
Q8010	TRANSISTOR	KRC402E	1	2218330R2	N
Q8010 or	TRANSISTOR	RN1102	( 1)	2218230R2	
Q8011	TRANSISTOR	KRC402E	1	2218330R2	N
Q8011 or	TRANSISTOR	RN1102	( 1)	2218230R2	
Q8101	HYBRID IC	W25Q128FVFIG	1	222W0136R2	firmware
Q8114	HYBRID IC	74LCX125FT	1	22274125BR2TO	
Q8202	HYBRID IC	ADV7180KCP32Z-RL	1	22242763R2	
Q8202 or	HYBRID IC	ADV7180KCP32Z	( 1)	22242763R3	
Q8203	HYBRID IC	S-1333A18-M5T1U3	1	22242956R2	
Q8205	HYBRID IC	S-1333A18-M5T1U3	1	22242956R2	
Q8300	HYBRID IC	S-13A1A13-U5T1U3	1	22242848R2	
Q8302	HYBRID IC	SI9573CTUC	1	22242762R3	
Q8303	TRANSISTOR	2SA1162-GR	1	2214375R2	
Q8307	HYBRID IC	S-1333A13-M5T1U3	1	22242957R2	
Q8400	TRANSISTOR	KRC405E	1	2218340R2	N
Q8400 or	TRANSISTOR	RN1105	( 1)	2218250R2	
Q8401	HYBRID IC	MN864787	1	22242944R3	N
Q8700	TRANSISTOR	RE1C001UNTCL	1	2218160R2	
Q8701	HYBRID IC	TMPM361F10FG	1	222W0115R3	firmware
Q8702	TRANSISTOR	KRC402E	1	2218330R2	N
Q8702 or	TRANSISTOR	RN1102	( 1)	2218230R2	
Q8703	TRANSISTOR	RE1C001UNTCL	1	2218160R2	
Q8704	TRANSISTOR	KRA302E	1	2218360R2	N
Q8704 or	TRANSISTOR	RN2102	( 1)	2218270R2	
Q8705	TRANSISTOR	KRC402E	1	2218330R2	N
Q8705 or	TRANSISTOR	RN1102	( 1)	2218230R2	
Q8706	TRANSISTOR	RE1C001UNTCL	1	2218160R2	
Q8707	TRANSISTOR	KRA302E	1	2218360R2	N
Q8707 or	TRANSISTOR	RN2102	( 1)	2218270R2	
Q8708	TRANSISTOR	KRC402E	1	2218330R2	N
Q8708 or	TRANSISTOR	RN1102	( 1)	2218230R2	
Q8709	TRANSISTOR	KRC402E	1	2218330R2	N
Q8709 or	TRANSISTOR	RN1102	( 1)	2218230R2	
Q8710	TRANSISTOR	KRC402E	1	2218330R2	N
Q8710 or	TRANSISTOR	RN1102	( 1)	2218230R2	
Q8711	TRANSISTOR	KRA302E	1	2218360R2	N
Q8711 or	TRANSISTOR	RN2102	( 1)	2218270R2	
Q8712	TRANSISTOR	KRC402E	1	2218330R2	N
Q8712 or	TRANSISTOR	RN1102	( 1)	2218230R2	
Q8713	TRANSISTOR	KRC402E	1	2218330R2	N
Q8713 or	TRANSISTOR	RN1102	( 1)	2218230R2	
Q8714	TRANSISTOR	KRC402E	1	2218330R2	N
Q8714 or	TRANSISTOR	RN1102	( 1)	2218230R2	
Q8715	TRANSISTOR	KRA302E	1	2218360R2	N
Q8715 or	TRANSISTOR	RN2102	( 1)	2218270R2	
Q8716	TRANSISTOR	KRC402E	1	2218330R2	N
Q8716 or	TRANSISTOR	RN1102	( 1)	2218230R2	
Q8725	TRANSISTOR	KRC402E	1	2218330R2	N
Q8725 or	TRANSISTOR	RN1102	( 1)	2218230R2	
Q8727	TRANSISTOR	KRC402E	1	2218330R2	N
Q8727 or	TRANSISTOR	RN1102	( 1)	2218230R2	
Q8729	TRANSISTOR	KRC402E	1	2218330R2	N
Q8729 or	TRANSISTOR	RN1102	( 1)	2218230R2	
Q8900	HYBRID IC	FP6861C-B1AS5CT	1	22242840R2	
Q8901	TRANSISTOR	KRC405E	1	2218340R2	N
Q8902	TRANSISTOR	KRA302E	1	2218360R2	N
Q8907	HYBRID IC	MM3404A50NRE	1	22242701R2	

Q8921	HYBRID IC	FR9888CSPCTR	1	22242839R2
Q8931	HYBRID IC	FR9888CSPCTR	1	22242839R2
Q8941	HYBRID IC	FR9888CSPCTR	1	22242839R2
Q8942	TRANSISTOR	2SC2712-GR	1	2213145R2
Q8944	HYBRID IC	TPS22924CZPZR	1	22242807R2
Q8946	HYBRID IC	TPS22924CZPZR	1	22242807R2
Q8951	HYBRID IC	FR9888CSPCTR	1	22242839R2
Q8952	TRANSISTOR	2SC2712-GR	1	2213145R2
Q8961	HYBRID IC	FR9888CSPCTR	1	22242839R2
Q8962	TRANSISTOR	2SC2712-GR	1	2213145R2
Q8965	HYBRID IC	MM3404A50NRE	1	22242701R2
Q8967	HYBRID IC	FP6861C-B1AS5CT	1	22242840R2
Q8975	HYBRID IC	XC6701B502PR	1	22242808R2
<b>[TRANS COIL]</b>				
L1900	CORE	BLM15PX181SN1D	1	2350033R1
L1901	CHOKE COIL	LBC2518T4R7M	1	231364M047R2
L1902	CORE	BLM15PX181SN1D	1	2350033R1
L1903	CHOKE COIL	LBC2518T4R7M	1	231364M047R2
L1904	CORE	BLM15PX181SN1D	1	2350033R1
L3001	CORE	BLM15PX121SN1D	1	2350034R1
L3002	CORE	BLM15PX121SN1D	1	2350034R1
L3003	CORE	BLM15PX121SN1D	1	2350034R1
L3004	CORE	BLM15PX121SN1D	1	2350034R1
L3005	CORE	BLM15PX121SN1D	1	2350034R1
L3100	CORE	BLM15PX121SN1D	1	2350034R1
L3103	CORE	BLM15PX121SN1D	1	2350034R1
L3104	CORE	BLM15PX121SN1D	1	2350034R1
L3105	CORE	BLM15PX121SN1D	1	2350034R1
L3106	CORE	BLM15PX121SN1D	1	2350034R1
L3107	CORE	BLM15PX121SN1D	1	2350034R1
L3108	CORE	BLM15PX121SN1D	1	2350034R1
L3109	CORE	BLM15PX121SN1D	1	2350034R1
L3110	CORE	BLM15PX121SN1D	1	2350034R1
L3111	CORE	BLM15PX121SN1D	1	2350034R1
L3112	CORE	MCF12102G900-T	1	2350041R2
L3114	CORE	BLM15PX121SN1D	1	2350034R1
L3145	CORE	MCF20104G900-T	1	2350040R2
L3203	CORE	BK1005LL241-T	1	2350032R1
L3209	CORE	BK1005LL241-T	1	2350032R1
L3290	CORE	BK1005LL241-T	1	2350032R1
L3401	CORE	BLM15PX181SN1D	1	2350033R1
L3403	CORE	BK1005LL241-T	1	2350032R1
L3405	CORE	BLM15PX121SN1D	1	2350034R1
L3406	CORE	BLM15PX330SN1D	1	2350043R1
L3407	CORE	BLM15PX121SN1D	1	2350034R1
L3408	CORE	BLM15PX121SN1D	1	2350034R1
L3409	CORE	BLM15PX181SN1D	1	2350033R1
L3411	CORE	BK1005LL241-T	1	2350032R1
L7003	CORE	BLM15PX181SN1D	1	2350033R1
L7007	CORE	BLM15PX181SN1D	1	2350033R1
L8000	CORE	BLM15PX121SN1D	1	2350034R1
L8001	CORE	EXC24CH900U	1	2350039R2
L8002	CORE	EXC24CH900U	1	2350039R2
L8003	CORE	EXC24CH900U	1	2350039R2
L8004	CORE	EXC24CH900U	1	2350039R2
L8005	CORE	BLM15PX121SN1D	1	2350034R1
L8006	CORE	BLM15PX121SN1D	1	2350034R1
L8007	CORE	BLM15PX121SN1D	1	2350034R1
L8008	CORE	BLM15PX121SN1D	1	2350034R1
L8009	CORE	BLM15PX121SN1D	1	2350034R1
L8010	CORE	BLM15PX121SN1D	1	2350034R1
L8011	CORE	BLM15PX121SN1D	1	2350034R1

L8012	CORE	BLM15PX121SN1D	1	2350034R1
L8013	CORE	BLM15PX121SN1D	1	2350034R1
L8014	CORE	BLM15PX121SN1D	1	2350034R1
L8015	CORE	BLM15PX121SN1D	1	2350034R1
L8016	CORE	BLM15PX121SN1D	1	2350034R1
L8017	CORE	BLM15PX121SN1D	1	2350034R1
L8018	CORE	BLM15PX121SN1D	1	2350034R1
L8021	CORE	EXC24CH900U	1	2350039R2
L8022	CORE	EXC24CH900U	1	2350039R2
L8023	CORE	EXC24CH900U	1	2350039R2
L8024	CORE	EXC24CH900U	1	2350039R2
L8202	CORE	BLM15PX181SN1D	1	2350033R1
L8205	CORE	BLM15PX181SN1D	1	2350033R1
L8207	CORE	BLM15PX181SN1D	1	2350033R1
L8210	CORE	BLM15PX181SN1D	1	2350033R1
L8300	CORE	BLM15PX181SN1D	1	2350033R1
L8302	CORE	BLM15PX181SN1D	1	2350033R1
L8303	CORE	BLM15PX181SN1D	1	2350033R1
L8304	CORE	BLM15PX181SN1D	1	2350033R1
L8305	CORE	BLM15PX181SN1D	1	2350033R1
L8306	CORE	BLM15PX181SN1D	1	2350033R1
L8307	CORE	BLM15PX181SN1D	1	2350033R1
L8308	CORE	BLM15PX181SN1D	1	2350033R1
L8400	CORE	BLM15PX121SN1D	1	2350034R1
L8401	CORE	BLM15PX121SN1D	1	2350034R1
L8402	CORE	BLM15PX121SN1D	1	2350034R1
L8403	CORE	BLM15PX121SN1D	1	2350034R1
L8404	CORE	BLM15PX121SN1D	1	2350034R1
L8405	CORE	BLM15PX121SN1D	1	2350034R1
L8406	CORE	BLM15PX121SN1D	1	2350034R1
L8407	CORE	BLM15PX121SN1D	1	2350034R1
L8408	CORE	BLM15PX121SN1D	1	2350034R1
L8409	CORE	BLM15PX121SN1D	1	2350034R1
L8410	CORE	BLM15PX121SN1D	1	2350034R1
L8411	CORE	BLM15PX121SN1D	1	2350034R1
L8412	CORE	BLM15PX121SN1D	1	2350034R1
L8413	CORE	BLM15PX121SN1D	1	2350034R1
L8415	CORE	BLM15PX121SN1D	1	2350034R1
L8416	CORE	BK1005LL241-T	1	2350032R1
L8417	CORE	BLM15PX181SN1D	1	2350033R1
L8418	CORE	BLM15PX181SN1D	1	2350033R1
L8702	CORE	BLM15PX181SN1D	1	2350033R1
L8921	CHOKE COIL	BLM21PG221SN1	1	230949R2
L8922	CHOKE COIL	C6-K5RA-10UH	1	231451P100R2
L8931	CHOKE COIL	BLM21PG221SN1	1	230949R2
L8932	CHOKE COIL	C6-K5RA-10UH	1	231451P100R2
L8941	CHOKE COIL	BLM21PG221SN1	1	230949R2
L8942	CHOKE COIL	C6-K5RA-10UH	1	231451P100R2
L8951	CHOKE COIL	BLM21PG221SN1	1	230949R2
L8952	CHOKE COIL	C6-K5RA-10UH	1	231451P100R2
L8961	CHOKE COIL	BLM21PG221SN1	1	230949R2
L8962	CHOKE COIL	C6-K5RA-10UH	1	231451P100R2
L8965	CORE	BLM15PX181SN1D	1	2350033R1
X3001	CRYSTAL	HC-49S 9C20.0000M	1	3010514R2
X3401	CRYSTAL	HC-49S 9C24.5760M	1	3010516R2
X7001	CRYSTAL	CSTCR4M00G53-R0	1	3010536R2
X8031	CRYSTAL	HC-49S 9C27.0000M	1	3010518R2
X8201	CRYSTAL	HC-49S 9C28.6363M	1	3010519R2
X8301	CRYSTAL	HC-49S 9C27.0000M	1	3010518R2
X8400	CRYSTAL	HC-49S 9C27.0000M	1	3010518R2
X8701	CERAMIC RESONATOR	CSTCE8M00G55-R0	1	3010416R2

[CAPACITOR]



















C8982	CHIP TYPE CERAMIC CAPACITOR	CK725B1A-105K0	1	332001055R1
C8983	CHIP TYPE CERAMIC CAPACITOR	CK732B16V-106K	1	332071065R2
<b>[RESISTOR]</b>				
R1900	CHIP TYPE CARBON RESISTOR	RN72K1J-331JE	1	435033314R1
R1901	CHIP TYPE CARBON RESISTOR	RN72K1J-151JE	1	435031514R1
R1902	CHIP TYPE CARBON RESISTOR	RN72K1J-151JE	1	435031514R1
R1903	CHIP TYPE CARBON RESISTOR	RN72K1J-151JE	1	435031514R1
R1904	CHIP TYPE CARBON RESISTOR	RN72K1J-331JE	1	435033314R1
R1905	CHIP TYPE CARBON RESISTOR	RN72K1J-221JE	1	435032214R1
R1906	CHIP TYPE CARBON RESISTOR	RN72K1J-221JE	1	435032214R1
R1907	CHIP TYPE CARBON RESISTOR	RN72K1J-471JE	1	435034714R1
R1908	CHIP TYPE CARBON RESISTOR	RN72K1J-471JE	1	435034714R1
R1909	CHIP TYPE CARBON RESISTOR	RN72K1J-103JE	1	435031034R1
R1911	CHIP TYPE CARBON RESISTOR	RN72K1J-151JE	1	435031514R1
R1912	CHIP TYPE CARBON RESISTOR	RN72K1J-151JE	1	435031514R1
R1913	CHIP TYPE CARBON RESISTOR	RN72K1J-151JE	1	435031514R1
R1914	CHIP TYPE CARBON RESISTOR	RN72K1J-331JE	1	435033314R1
R1915	CHIP TYPE CARBON RESISTOR	RN72K1J-471JE	1	435034714R1
R1916	CHIP TYPE CARBON RESISTOR	RN72K1J-471JE	1	435034714R1
R1917	CHIP TYPE CARBON RESISTOR	RN72K1J-103JE	1	435031034R1
R1919	CHIP TYPE CARBON RESISTOR	RN72K1J-151JE	1	435031514R1
R1920	CHIP TYPE CARBON RESISTOR	RN72K1J-151JE	1	435031514R1
R3007	CHIP TYPE CARBON RESISTOR	RN72K1J-470JE	1	435034704R1
R3009	CHIP TYPE CARBON RESISTOR	RN72K1J-330JE	1	435033304R1
R3010	CHIP RESISTOR NETWORK	MNR04MRAPJ330	1	43464733004R2
R3010 or	CHIP RESISTOR NETWORK	YCN104-330-JK	(1)	43464C33004R1
R3011	CHIP RESISTOR NETWORK	MNR04MRAPJ330	1	43464733004R2
R3011 or	CHIP RESISTOR NETWORK	YCN104-330-JK	(1)	43464C33004R1
R3012	CHIP RESISTOR NETWORK	MNR04MRAPJ470	1	43464747004R2
R3012 or	CHIP RESISTOR NETWORK	YCN104-470-JK	(1)	43464C47004R1
R3013	CHIP RESISTOR NETWORK	MNR04MRAPJ330	1	43464733004R2
R3013 or	CHIP RESISTOR NETWORK	YCN104-330-JK	(1)	43464C33004R1
R3014	CHIP RESISTOR NETWORK	MNR04MRAPJ330	1	43464733004R2
R3014 or	CHIP RESISTOR NETWORK	YCN104-330-JK	(1)	43464C33004R1
R3015	CHIP RESISTOR NETWORK	MNR04MRAPJ330	1	43464733004R2
R3015 or	CHIP RESISTOR NETWORK	YCN104-330-JK	(1)	43464C33004R1
R3016	CHIP TYPE CARBON RESISTOR	RN72K1J-470JE	1	435034704R1
R3017	CHIP RESISTOR NETWORK	MNR04MRAPJ330	1	43464733004R2
R3017 or	CHIP RESISTOR NETWORK	YCN104-330-JK	(1)	43464C33004R1
R3018	CHIP TYPE CARBON RESISTOR	RN72K1J-470JE	1	435034704R1
R3019	CHIP RESISTOR NETWORK	MNR04MRAPJ330	1	43464733004R2
R3019 or	CHIP RESISTOR NETWORK	YCN104-330-JK	(1)	43464C33004R1
R3020	CHIP RESISTOR NETWORK	MNR04MRAPJ330	1	43464733004R2
R3020 or	CHIP RESISTOR NETWORK	YCN104-330-JK	(1)	43464C33004R1
R3021	CHIP TYPE CARBON RESISTOR	RN72K1J-470JE	1	435034704R1
R3022	CHIP TYPE CARBON RESISTOR	RN72K1J-470JE	1	435034704R1
R3023	CHIP RESISTOR NETWORK	MNR04MRAPJ470	1	43464747004R2
R3023 or	CHIP RESISTOR NETWORK	YCN104-470-JK	(1)	43464C47004R1
R3024	CHIP TYPE CARBON RESISTOR	RN72K1J-470JE	1	435034704R1
R3025	CHIP TYPE CARBON RESISTOR	RN72K1J-102JE	1	435031024R1
R3028	CHIP TYPE CARBON RESISTOR	RN72K1J-470JE	1	435034704R1
R3029	CHIP TYPE CARBON RESISTOR	RN72K1J-102JE	1	435031024R1
R3032	CHIP TYPE CARBON RESISTOR	RN72K1J-103JE	1	435031034R1
R3033	CHIP TYPE CARBON RESISTOR	RN72K1J-470JE	1	435034704R1
R3034	CHIP TYPE CARBON RESISTOR	RN72K1J-470JE	1	435034704R1
R3035	CHIP TYPE CARBON RESISTOR	RN72K1J-470JE	1	435034704R1
R3036	CHIP TYPE CARBON RESISTOR	RN72K1J-470JE	1	435034704R1
R3037	CHIP TYPE CARBON RESISTOR	RN72K1J-470JE	1	435034704R1
R3038	CHIP TYPE CARBON RESISTOR	RN72K1J-470JE	1	435034704R1
R3039	CHIP TYPE CARBON RESISTOR	RN72K1J-470JE	1	435034704R1
R3040	CHIP TYPE CARBON RESISTOR	RN72K1J-103JE	1	435031034R1
R3041	CHIP RESISTOR NETWORK	MNR04MRAPJ330	1	43464733004R2

R3041 or	CHIP RESISTOR NETWORK	YCN104-330-JK	( 1)	43464C33004R1
R3042	CHIP RESISTOR NETWORK	MNR04MRAPJ330	1	43464733004R2
R3042 or	CHIP RESISTOR NETWORK	YCN104-330-JK	( 1)	43464C33004R1
R3043	CHIP TYPE CARBON RESISTOR	RN72K1J-000JE	1	435030004R1
R3044	CHIP RESISTOR NETWORK	MNR04MRAPJ330	1	43464733004R2
R3044 or	CHIP RESISTOR NETWORK	YCN104-330-JK	( 1)	43464C33004R1
R3045	CHIP RESISTOR NETWORK	MNR04MRAPJ330	1	43464733004R2
R3045 or	CHIP RESISTOR NETWORK	YCN104-330-JK	( 1)	43464C33004R1
R3047	CHIP TYPE CARBON RESISTOR	RN72K1J-560JE	1	435035604R1
R3048	CHIP TYPE CARBON RESISTOR	RN72K1J-221JE	1	435032214R1
R3049	CHIP TYPE CARBON RESISTOR	RN72K1J-560JE	1	435035604R1
R3050	CHIP TYPE CARBON RESISTOR	RN72K1J-560JE	1	435035604R1
R3051	CHIP TYPE CARBON RESISTOR	RN72K1J-560JE	1	435035604R1
R3054	CHIP TYPE CARBON RESISTOR	RN72K1J-103JE	1	435031034R1
R3056	CHIP TYPE CARBON RESISTOR	RN72K1J-472JE	1	435034724R1
R3060	CHIP TYPE CARBON RESISTOR	RN72K1J-680JE	1	435036804R1
R3061	CHIP TYPE CARBON RESISTOR	RN72K1J-470JE	1	435034704R1
R3062	CHIP TYPE CARBON RESISTOR	RN72K1J-680JE	1	435036804R1
R3063	CHIP TYPE CARBON RESISTOR	RN72K1J-680JE	1	435036804R1
R3064	CHIP TYPE CARBON RESISTOR	RN72K1J-680JE	1	435036804R1
R3065	CHIP TYPE CARBON RESISTOR	RN72K1J-680JE	1	435036804R1
R3066	CHIP TYPE CARBON RESISTOR	RN72K1J-102JE	1	435031024R1
R3105	CHIP RESISTOR NETWORK	MNR04MRAPJ220	1	43464722004R2
R3105 or	CHIP RESISTOR NETWORK	YCN104-220-JK	( 1)	43464C22004R1
R3108	CHIP TYPE CARBON RESISTOR	RN72K1J-103JE	1	435031034R1
R3110	CHIP TYPE CARBON RESISTOR	RN72K1J-103JE	1	435031034R1
R3111	CHIP TYPE CARBON RESISTOR	RN72K1J-103JE	1	435031034R1
R3113	CHIP TYPE CARBON RESISTOR	RN72K1J-103JE	1	435031034R1
R3115	CHIP TYPE CARBON RESISTOR	RN72K1J-332JE	1	435033324R1
R3117	CHIP TYPE CARBON RESISTOR	RN72K1J-332JE	1	435033324R1
R3119	CHIP TYPE CARBON RESISTOR	RN72K1J-332JE	1	435033324R1
R3121	CHIP TYPE CARBON RESISTOR	RN72K1J-680JE	1	435036804R1
R3122	CHIP TYPE CARBON RESISTOR	RN72K1J-102JE	1	435031024R1
R3123	CHIP TYPE CARBON RESISTOR	RN72K1J-000JE	1	435030004R1
R3124	CHIP TYPE CARBON RESISTOR	RN72K1J-331JE	1	435033314R1
R3125	CHIP TYPE CARBON RESISTOR	RN72K1J-470JE	1	435034704R1
R3126	CHIP TYPE CARBON RESISTOR	RN72K1J-470JE	1	435034704R1
R3127	CHIP TYPE CARBON RESISTOR	RN72K1J-470JE	1	435034704R1
R3128	CHIP TYPE CARBON RESISTOR	RN72K1J-472JE	1	435034724R1
R3129	CHIP TYPE CARBON RESISTOR	RN72K1J-470JE	1	435034704R1
R3130	CHIP TYPE CARBON RESISTOR	RN72K1J-470JE	1	435034704R1
R3131	CHIP TYPE CARBON RESISTOR	RN72K1J-470JE	1	435034704R1
R3132	CHIP TYPE CARBON RESISTOR	RN72K1J-103JE	1	435031034R1
R3133	CHIP TYPE CARBON RESISTOR	RN72K1J-470JE	1	435034704R1
R3134	CHIP TYPE CARBON RESISTOR	RN72K1J-472JE	1	435034724R1
R3135	CHIP TYPE CARBON RESISTOR	RN72K1J-472JE	1	435034724R1
R3136	CHIP TYPE CARBON RESISTOR	RN72K1J-000JE	1	435030004R1
R3137	CHIP TYPE CARBON RESISTOR	RN72K1J-000JE	1	435030004R1
R3138	CHIP TYPE CARBON RESISTOR	RN72K1J-103JE	1	435031034R1
R3139	CHIP TYPE CARBON RESISTOR	RN72K1J-101JE	1	435031014R1
R3143	CHIP TYPE CARBON RESISTOR	RN72K1J-332JE	1	435033324R1
R3144	CHIP TYPE CARBON RESISTOR	RN72K1J-101JE	1	435031014R1
R3145	CHIP TYPE CARBON RESISTOR	RN72K1J-332JE	1	435033324R1
R3146	CHIP TYPE CARBON RESISTOR	RN72K1J-390JE	1	435033904R1
R3148	CHIP TYPE CARBON RESISTOR	RN72K1J-390JE	1	435033904R1
R3154	CHIP TYPE CARBON RESISTOR	RN72K1J-390JE	1	435033904R1
R3155	CHIP TYPE CARBON RESISTOR	RN72K1J-390JE	1	435033904R1
R3156	CHIP TYPE CARBON RESISTOR	RN72K1J-390JE	1	435033904R1
R3157	CHIP TYPE CARBON RESISTOR	RN72K1J-101JE	1	435031014R1
R3162	CHIP TYPE CARBON RESISTOR	RN72K1J-390JE	1	435033904R1
R3163	CHIP TYPE CARBON RESISTOR	RN72K1J-220JE	1	435032204R1
R3164	CHIP TYPE CARBON RESISTOR	RN72K1J-102JE	1	435031024R1

R3168	CHIP TYPE CARBON RESISTOR	RN72K1J-220JE	1	435032204R1
R3169	CHIP TYPE CARBON RESISTOR	RN72K1J-220JE	1	435032204R1
R3170	CHIP TYPE CARBON RESISTOR	RN72K1J-391FE	1	435033912R1
R3171	CHIP TYPE CARBON RESISTOR	RN72K1J-222FE	1	435032222R1
R3172	CHIP TYPE CARBON RESISTOR	RN72K1J-392FE	1	435033922R1
R3173	CHIP TYPE CARBON RESISTOR	RN72K1J-390JE	1	435033904R1
R3174	CHIP TYPE CARBON RESISTOR	RN72K1J-390JE	1	435033904R1
R3175	CHIP TYPE CARBON RESISTOR	RN72K1J-472JE	1	435034724R1
R3181	CHIP TYPE CARBON RESISTOR	RN72K1J-470JE	1	435034704R1
R3182	CHIP TYPE CARBON RESISTOR	RN72K1J-472JE	1	435034724R1
R3183	CHIP TYPE CARBON RESISTOR	RN72K1J-470JE	1	435034704R1
R3184	CHIP TYPE CARBON RESISTOR	RN72K1J-470JE	1	435034704R1
R3187	CHIP TYPE CARBON RESISTOR	RN72K1J-472JE	1	435034724R1
R3188	CHIP TYPE CARBON RESISTOR	RN72K1J-103JE	1	435031034R1
R3190	CHIP TYPE CARBON RESISTOR	RN72K1J-103JE	1	435031034R1
R3192	CHIP TYPE CARBON RESISTOR	RN72K1J-472JE	1	435034724R1
R3193	CHIP TYPE CARBON RESISTOR	RN72K1J-472JE	1	435034724R1
R3194	CHIP TYPE CARBON RESISTOR	RN72K1J-472JE	1	435034724R1
R3199	CHIP TYPE CARBON RESISTOR	RN72K1J-102JE	1	435031024R1
R3200	CHIP TYPE CARBON RESISTOR	RN72K1J-000JE	1	435030004R1
R3201	CHIP RESISTOR NETWORK	MNR04MRAPJ470	1	43464747004R2
R3201 or	CHIP RESISTOR NETWORK	YCN104-470-JK	( 1 )	43464C47004R1
R3202	CHIP TYPE CARBON RESISTOR	RN72K1J-470JE	1	435034704R1
R3203	CHIP TYPE CARBON RESISTOR	RN72K1J-470JE	1	435034704R1
R3204	CHIP TYPE CARBON RESISTOR	RN72K1J-103JE	1	435031034R1
R3205	CHIP TYPE CARBON RESISTOR	RN72K1J-470JE	1	435034704R1
R3207	CHIP TYPE CARBON RESISTOR	RN72K1J-103JE	1	435031034R1
R3208	CHIP TYPE CARBON RESISTOR	RN72K1J-221JE	1	435032214R1
R3209	CHIP TYPE CARBON RESISTOR	RN72K1J-470JE	1	435034704R1
R3211	CHIP TYPE CARBON RESISTOR	RN72K1J-151JE	1	435031514R1
R3212	CHIP TYPE CARBON RESISTOR	RN72K1J-220JE	1	435032204R1
R3213	CHIP TYPE CARBON RESISTOR	RN72K1J-103JE	1	435031034R1
R3218	CHIP TYPE CARBON RESISTOR	RN72K1J-220JE	1	435032204R1
R3226	CHIP RESISTOR NETWORK	MNR04MRAPJ470	1	43464747004R2
R3226 or	CHIP RESISTOR NETWORK	YCN104-470-JK	( 1 )	43464C47004R1
R3234	CHIP TYPE CARBON RESISTOR	RN72K1J-470JE	1	435034704R1
R3238	CHIP TYPE CARBON RESISTOR	RN72K1J-470JE	1	435034704R1
R3244	CHIP TYPE CARBON RESISTOR	RN72K1J-470JE	1	435034704R1
R3247	CHIP TYPE CARBON RESISTOR	RN72K1J-121JE	1	435031214R1
R3251	CHIP TYPE CARBON RESISTOR	RN72K1J-470JE	1	435034704R1
R3257	CHIP TYPE CARBON RESISTOR	RN72K1J-470JE	1	435034704R1
R3260	CHIP TYPE CARBON RESISTOR	RN72K1J-221JE	1	435032214R1
R3262	CHIP TYPE CARBON RESISTOR	RN72K1J-221JE	1	435032214R1
R3265	CHIP TYPE CARBON RESISTOR	RN72K1J-390JE	1	435033904R1
R3268	CHIP TYPE CARBON RESISTOR	RN72K1J-390JE	1	435033904R1
R3271	CHIP TYPE CARBON RESISTOR	RN72K1J-390JE	1	435033904R1
R3272	CHIP TYPE CARBON RESISTOR	RN72K1J-470JE	1	435034704R1
R3274	CHIP TYPE CARBON RESISTOR	RN72K1J-390JE	1	435033904R1
R3275	CHIP TYPE CARBON RESISTOR	RN72K1J-332JE	1	435033324R1
R3277	CHIP TYPE CARBON RESISTOR	RN72K1J-220JE	1	435032204R1
R3278	CHIP TYPE CARBON RESISTOR	RN72K1J-470JE	1	435034704R1
R3281	CHIP TYPE CARBON RESISTOR	RN72K1J-103JE	1	435031034R1
R3283	CHIP TYPE CARBON RESISTOR	RN72K1J-470JE	1	435034704R1
R3284	CHIP TYPE CARBON RESISTOR	RN72K1J-103JE	1	435031034R1
R3285	CHIP TYPE CARBON RESISTOR	RN72K1J-332JE	1	435033324R1
R3286	CHIP TYPE CARBON RESISTOR	RN72K1J-332JE	1	435033324R1
R3289	CHIP TYPE CARBON RESISTOR	RN72K1J-332JE	1	435033324R1
R3290	CHIP TYPE CARBON RESISTOR	RN72K1J-470JE	1	435034704R1
R3291	CHIP RESISTOR NETWORK	MNR04MRAPJ470	1	43464747004R2
R3291 or	CHIP RESISTOR NETWORK	YCN104-470-JK	( 1 )	43464C47004R1
R3293	CHIP TYPE CARBON RESISTOR	RN72K1J-101JE	1	435031014R1
R3297	CHIP TYPE CARBON RESISTOR	RN72K1J-103JE	1	435031034R1



R3400	CHIP TYPE CARBON RESISTOR	RN72K1J-223JE	1	435032234R1
R3401	CHIP TYPE CARBON RESISTOR	RN72K1J-470JE	1	435034704R1
R3403	CHIP TYPE CARBON RESISTOR	RN72K1J-221JE	1	435032214R1
R3404	CHIP TYPE CARBON RESISTOR	RN72K1J-470JE	1	435034704R1
R3405	CHIP TYPE CARBON RESISTOR	RN72K1J-470JE	1	435034704R1
R3406	CHIP TYPE CARBON RESISTOR	RN72K1J-332JE	1	435033324R1
R3407	CHIP TYPE CARBON RESISTOR	RN72K1J-222JE	1	435032224R1
R3408	CHIP RESISTOR NETWORK	MNR04MRAPJ221	1	43464722104R2
R3408 or	CHIP RESISTOR NETWORK	YCN104-221-JK	(1)	43464C22104R1
R3409	CHIP RESISTOR NETWORK	MNR04MRAPJ221	1	43464722104R2
R3409 or	CHIP RESISTOR NETWORK	YCN104-221-JK	(1)	43464C22104R1
R3411	CHIP RESISTOR NETWORK	MNR04MRAPJ000	1	43464700004R2
R3411 or	CHIP RESISTOR NETWORK	YCN104-000-ZK	(1)	43484C00004R1
R3412	CHIP TYPE CARBON RESISTOR	RN72K1J-472JE	1	435034724R1
R3414	CHIP TYPE CARBON RESISTOR	RN72K1J-103JE	1	435031034R1
R3415	CHIP RESISTOR NETWORK	MNR04MRAPJ000	1	43464700004R2
R3415 or	CHIP RESISTOR NETWORK	YCN104-000-ZK	(1)	43484C00004R1
R3421	CHIP TYPE CARBON RESISTOR	RN72K1J-470JE	1	435034704R1
R3424	CHIP TYPE CARBON RESISTOR	RN72K1J-470JE	1	435034704R1
R3425	CHIP TYPE CARBON RESISTOR	RN72K1J-470JE	1	435034704R1
R3428	CHIP TYPE CARBON RESISTOR	RN72K1J-472JE	1	435034724R1
R3429	CHIP RESISTOR NETWORK	MNR04MRAPJ470	1	43464747004R2
R3429 or	CHIP RESISTOR NETWORK	YCN104-470-JK	(1)	43464C47004R1
R3430	CHIP RESISTOR NETWORK	MNR04MRAPJ470	1	43464747004R2
R3430 or	CHIP RESISTOR NETWORK	YCN104-470-JK	(1)	43464C47004R1
R3432	CHIP TYPE CARBON RESISTOR	RN72K1J-103JE	1	435031034R1
R3433	CHIP TYPE CARBON RESISTOR	RN72K1J-103JE	1	435031034R1
R3434	CHIP TYPE CARBON RESISTOR	RN72K1J-332JE	1	435033324R1
R3435	CHIP TYPE CARBON RESISTOR	RN72K1J-222JE	1	435032224R1
R3436	CHIP TYPE CARBON RESISTOR	RN72K1J-101JE	1	435031014R1
R3437	CHIP TYPE CARBON RESISTOR	RN72K1J-470JE	1	435034704R1
R3438	CHIP TYPE CARBON RESISTOR	RN72K1J-470JE	1	435034704R1
R3439	CHIP TYPE CARBON RESISTOR	RN72K1J-332JE	1	435033324R1
R3440	CHIP TYPE CARBON RESISTOR	RN72K1J-332JE	1	435033324R1
R3441	CHIP RESISTOR NETWORK	MNR04MRAPJ470	1	43464747004R2
R3441 or	CHIP RESISTOR NETWORK	YCN104-470-JK	(1)	43464C47004R1
R3442	CHIP TYPE CARBON RESISTOR	RN72K1J-105JE	1	435031054R1
R3443	CHIP TYPE CARBON RESISTOR	RN72K1J-101JE	1	435031014R1
R3444	CHIP TYPE CARBON RESISTOR	RN72K1J-470JE	1	435034704R1
R3445	CHIP RESISTOR NETWORK	MNR04MRAPJ470	1	43464747004R2
R3445 or	CHIP RESISTOR NETWORK	YCN104-470-JK	(1)	43464C47004R1
R3446	CHIP TYPE CARBON RESISTOR	RN72K1J-102JE	1	435031024R1
R3447	CHIP TYPE CARBON RESISTOR	RN72K1J-470JE	1	435034704R1
R3448	CHIP TYPE CARBON RESISTOR	RN72K1J-470JE	1	435034704R1
R3450	CHIP TYPE CARBON RESISTOR	RN72K1J-470JE	1	435034704R1
R3452	CHIP TYPE CARBON RESISTOR	RN72K1J-470JE	1	435034704R1
R3453	CHIP TYPE CARBON RESISTOR	RN72K1J-121JE	1	435031214R1
R3454	CHIP TYPE CARBON RESISTOR	RN72K1J-470JE	1	435034704R1
R3455	CHIP TYPE CARBON RESISTOR	RN72K1J-101JE	1	435031014R1
R3456	CHIP TYPE CARBON RESISTOR	RN72K1J-470JE	1	435034704R1
R3457	CHIP RESISTOR NETWORK	MNR04MRAPJ470	1	43464747004R2
R3457 or	CHIP RESISTOR NETWORK	YCN104-470-JK	(1)	43464C47004R1
R3462	CHIP TYPE CARBON RESISTOR	RN72K1J-102JE	1	435031024R1
R3464	CHIP TYPE CARBON RESISTOR	RN72K1J-102JE	1	435031024R1
R3465	CHIP TYPE CARBON RESISTOR	RN72K1J-102JE	1	435031024R1
R3466	CHIP TYPE CARBON RESISTOR	RN72K1J-102JE	1	435031024R1
R3469	CHIP TYPE CARBON RESISTOR	RN72K1J-222JE	1	435032224R1
R3470	CHIP TYPE CARBON RESISTOR	RN72K1J-222JE	1	435032224R1
R3473	CHIP TYPE CARBON RESISTOR	RN72K1J-103JE	1	435031034R1
R3474	CHIP TYPE CARBON RESISTOR	RN72K1J-103JE	1	435031034R1
R3481	CHIP TYPE CARBON RESISTOR	RN72K1J-332JE	1	435033324R1
R3484	CHIP TYPE CARBON RESISTOR	RN72K1J-470JE	1	435034704R1

R3485	CHIP TYPE CARBON RESISTOR	RN72K1J-470JE	1	435034704R1
R3488	CHIP TYPE CARBON RESISTOR	RN72K1J-332JE	1	435033324R1
R3491	CHIP TYPE CARBON RESISTOR	RN72K1J-332JE	1	435033324R1
R3494	CHIP RESISTOR NETWORK	MNR04MRAPJ470	1	43464747004R2
R3494 or	CHIP RESISTOR NETWORK	YCN104-470-JK	(1)	43464C47004R1
R3495	CHIP RESISTOR NETWORK	MNR04MRAPJ470	1	43464747004R2
R3495 or	CHIP RESISTOR NETWORK	YCN104-470-JK	(1)	43464C47004R1
R3496	CHIP RESISTOR NETWORK	MNR04MRAPJ470	1	43464747004R2
R3496 or	CHIP RESISTOR NETWORK	YCN104-470-JK	(1)	43464C47004R1
R3497	CHIP RESISTOR NETWORK	MNR04MRAPJ470	1	43464747004R2
R3497 or	CHIP RESISTOR NETWORK	YCN104-470-JK	(1)	43464C47004R1
R3500	CHIP TYPE CARBON RESISTOR	RN72K1J-470JE	1	435034704R1
R3501	CHIP TYPE CARBON RESISTOR	RN72K1J-470JE	1	435034704R1
R3502	CHIP TYPE CARBON RESISTOR	RN72K1J-470JE	1	435034704R1
R3503	CHIP TYPE CARBON RESISTOR	RN72K1J-470JE	1	435034704R1
R3504	CHIP TYPE CARBON RESISTOR	RN72K1J-470JE	1	435034704R1
R3505	CHIP TYPE CARBON RESISTOR	RN72K1J-470JE	1	435034704R1
R7001	CHIP RESISTOR NETWORK	MNR04MRAPJ470	1	43464747004R2
R7001 or	CHIP RESISTOR NETWORK	YCN104-470-JK	(1)	43464C47004R1
R7002	CHIP TYPE CARBON RESISTOR	RN72K1J-103JE	1	435031034R1
R7003	CHIP TYPE CARBON RESISTOR	RN72K1J-103JE	1	435031034R1
R7005	CHIP TYPE CARBON RESISTOR	RN72K1J-223JE	1	435032234R1
R7006	CHIP TYPE CARBON RESISTOR	RN72K1J-223JE	1	435032234R1
R7007	CHIP TYPE CARBON RESISTOR	RN72K1J-105JE	1	435031054R1
R7008	CHIP TYPE CARBON RESISTOR	RN72K1J-473JE	1	435034734R1
R7009	CHIP TYPE CARBON RESISTOR	RN72K1J-105JE	1	435031054R1
R7010	CHIP TYPE CARBON RESISTOR	RN72K1J-103JE	1	435031034R1
R7011	CHIP TYPE CARBON RESISTOR	RN72K1J-103JE	1	435031034R1
R7012	CHIP TYPE CARBON RESISTOR	RN72K1J-103JE	1	435031034R1
R7013	CHIP TYPE CARBON RESISTOR	RN72K1J-103JE	1	435031034R1
R7014	CHIP TYPE CARBON RESISTOR	RN72K1J-473JE	1	435034734R1
R7015	CHIP TYPE CARBON RESISTOR	RN72K1J-473JE	1	435034734R1
R7016	CHIP TYPE CARBON RESISTOR	RN72K1J-473JE	1	435034734R1
R7017	CHIP RESISTOR NETWORK	MNR04MRAPJ472	1	43464747204R2
R7017 or	CHIP RESISTOR NETWORK	YCN104-472-JK	(1)	43464C47204R1
R7018	CHIP TYPE CARBON RESISTOR	RN72K1J-221JE	1	435032214R1
R7019	CHIP RESISTOR NETWORK	MNR04MRAPJ221	1	43464722104R2
R7019 or	CHIP RESISTOR NETWORK	YCN104-221-JK	(1)	43464C22104R1
R7020	CHIP TYPE CARBON RESISTOR	RN72K1J-221JE	1	435032214R1
R7021	CHIP RESISTOR NETWORK	MNR04MRAPJ221	1	43464722104R2
R7021 or	CHIP RESISTOR NETWORK	YCN104-221-JK	(1)	43464C22104R1
R7022	CHIP TYPE CARBON RESISTOR	RN72K1J-470JE	1	435034704R1
R7023	CHIP TYPE CARBON RESISTOR	RN72K1J-105JE	1	435031054R1
R7024	CHIP TYPE CARBON RESISTOR	RN72K1J-470JE	1	435034704R1
R7025	CHIP TYPE CARBON RESISTOR	RN72K1J-224JE	1	435032244R1
R7026	CHIP TYPE CARBON RESISTOR	RN72K1J-224JE	1	435032244R1
R7027	CHIP TYPE CARBON RESISTOR	RN72K1J-470JE	1	435034704R1
R7028	CHIP TYPE CARBON RESISTOR	RN72K1J-470JE	1	435034704R1
R7029	CHIP TYPE CARBON RESISTOR	RN72K1J-102JE	1	435031024R1
R7030	CHIP TYPE CARBON RESISTOR	RN72K1J-221JE	1	435032214R1
R7031	CHIP RESISTOR NETWORK	MNR04MRAPJ221	1	43464722104R2
R7031 or	CHIP RESISTOR NETWORK	YCN104-221-JK	(1)	43464C22104R1
R7032	CHIP TYPE CARBON RESISTOR	RN72K1J-470JE	1	435034704R1
R7033	CHIP RESISTOR NETWORK	MNR04MRAPJ470	1	43464747004R2
R7033 or	CHIP RESISTOR NETWORK	YCN104-470-JK	(1)	43464C47004R1
R7034	CHIP RESISTOR NETWORK	MNR04MRAPJ221	1	43464722104R2
R7034 or	CHIP RESISTOR NETWORK	YCN104-221-JK	(1)	43464C22104R1
R7035	CHIP TYPE CARBON RESISTOR	RN72K1J-470JE	1	435034704R1
R7036	CHIP TYPE CARBON RESISTOR	RN72K1J-102JE	1	435031024R1
R7037	CHIP TYPE CARBON RESISTOR	RN72K1J-102JE	1	435031024R1
R7038	CHIP TYPE CARBON RESISTOR	RN72K1J-102JE	1	435031024R1
R7039	CHIP TYPE CARBON RESISTOR	RN72K1J-222JE	1	435032224R1

R7040	CHIP TYPE CARBON RESISTOR	RN72K1J-222JE	1	435032224R1
R7041	CHIP TYPE CARBON RESISTOR	RN72K1J-222JE	1	435032224R1
R7042	CHIP RESISTOR NETWORK	MNR04MRAPJ221	1	43464722104R2
R7042 or	CHIP RESISTOR NETWORK	YCN104-221-JK	( 1)	43464C22104R1
R7044	CHIP TYPE CARBON RESISTOR	RN72K1J-470JE	1	435034704R1
R7046	CHIP TYPE CARBON RESISTOR	RN72K1J-221JE	1	435032214R1
R7048	CHIP TYPE CARBON RESISTOR	RN72K1J-221JE	1	435032214R1
R7049	CHIP TYPE CARBON RESISTOR	RN72K1J-470JE	1	435034704R1
R7050	CHIP TYPE CARBON RESISTOR	RN72K1J-103JE	1	435031034R1
R7051	CHIP TYPE CARBON RESISTOR	RN72K1J-105JE	1	435031054R1
R7052	CHIP TYPE CARBON RESISTOR	RN72K1J-105JE	1	435031054R1
R7053	CHIP TYPE CARBON RESISTOR	RN72K1J-105JE	1	435031054R1
R7054	CHIP TYPE CARBON RESISTOR	RN72K1J-102JE	1	435031024R1
R7055	CHIP TYPE CARBON RESISTOR	RN72K1J-102JE	1	435031024R1
R7056	CHIP TYPE CARBON RESISTOR	RN72K1J-102JE	1	435031024R1
R7059	CHIP TYPE CARBON RESISTOR	RN72K1J-224JE	1	435032244R1
R7060	CHIP TYPE CARBON RESISTOR	RN72K1J-473JE	1	435034734R1
R7061	CHIP RESISTOR NETWORK	MNR04MRAPJ221	1	43464722104R2
R7061 or	CHIP RESISTOR NETWORK	YCN104-221-JK	( 1)	43464C22104R1
R7062	CHIP TYPE CARBON RESISTOR	RN72K1J-103JE	1	435031034R1
R7063	CHIP TYPE CARBON RESISTOR	RN72K1J-103JE	1	435031034R1
R7064	CHIP TYPE CARBON RESISTOR	RN72K1J-222JE	1	435032224R1
R7065	CHIP TYPE CARBON RESISTOR	RN72K1J-473JE	1	435034734R1
R7066	CHIP TYPE CARBON RESISTOR	RN72K1J-470JE	1	435034704R1
R7067	CHIP TYPE CARBON RESISTOR	RN72K1J-000JE	1	435030004R1
R7068	CHIP TYPE CARBON RESISTOR	RN72K1J-000JE	1	435030004R1
R7069	CHIP RESISTOR NETWORK	MNR04MRAPJ470	1	43464747004R2
R7069 or	CHIP RESISTOR NETWORK	YCN104-470-JK	( 1)	43464C47004R1
R7070	CHIP RESISTOR NETWORK	MNR04MRAPJ221	1	43464722104R2
R7070 or	CHIP RESISTOR NETWORK	YCN104-221-JK	( 1)	43464C22104R1
R7071	CHIP TYPE CARBON RESISTOR	RN72K1J-103JE	1	435031034R1
R7072	CHIP TYPE CARBON RESISTOR	RN72K1J-470JE	1	435034704R1
R7073	CHIP TYPE CARBON RESISTOR	RN72K1J-102JE	1	435031024R1
R7074	CHIP TYPE CARBON RESISTOR	RN72K1J-470JE	1	435034704R1
R7075	CHIP RESISTOR NETWORK	MNR04MRAPJ470	1	43464747004R2
R7075 or	CHIP RESISTOR NETWORK	YCN104-470-JK	( 1)	43464C47004R1
R7076	CHIP TYPE CARBON RESISTOR	RN72K1J-221JE	1	435032214R1
R7077	CHIP TYPE CARBON RESISTOR	RN72K1J-103JE	1	435031034R1
R7078	CHIP TYPE CARBON RESISTOR	RN72K1J-103JE	1	435031034R1
R7079	CHIP RESISTOR NETWORK	MNR04MRAPJ221	1	43464722104R2
R7079 or	CHIP RESISTOR NETWORK	YCN104-221-JK	( 1)	43464C22104R1
R7080	CHIP TYPE CARBON RESISTOR	RN72K1J-103JE	1	435031034R1
R7081	CHIP RESISTOR NETWORK	MNR04MRAPJ221	1	43464722104R2
R7081 or	CHIP RESISTOR NETWORK	YCN104-221-JK	( 1)	43464C22104R1
R7082	CHIP TYPE CARBON RESISTOR	RN72K1J-104JE	1	435031044R1
R7083	CHIP TYPE CARBON RESISTOR	RN72K1J-332JE	1	435033324R1
R7084	CHIP TYPE CARBON RESISTOR	RN72K1J-331JE	1	435033314R1
R7087	CHIP TYPE CARBON RESISTOR	RN72K1J-273JE	1	435032734R1
R7091	CHIP TYPE CARBON RESISTOR	RN72K1J-221JE	1	435032214R1
R7092	CHIP TYPE CARBON RESISTOR	RN72K1J-470JE	1	435034704R1
R7093	CHIP TYPE CARBON RESISTOR	RN72K1J-472JE	1	435034724R1
R7094	CHIP TYPE CARBON RESISTOR	RN72K1J-472JE	1	435034724R1
R7095	CHIP RESISTOR NETWORK	MNR04MRAPJ221	1	43464722104R2
R7095 or	CHIP RESISTOR NETWORK	YCN104-221-JK	( 1)	43464C22104R1
R7098	CHIP RESISTOR NETWORK	MNR04MRAPJ221	1	43464722104R2
R7098 or	CHIP RESISTOR NETWORK	YCN104-221-JK	( 1)	43464C22104R1
R7099	CHIP RESISTOR NETWORK	MNR04MRAPJ470	1	43464747004R2
R7099 or	CHIP RESISTOR NETWORK	YCN104-470-JK	( 1)	43464C47004R1
R7101	CHIP TYPE CARBON RESISTOR	RN72K1J-221JE	1	435032214R1
R7103	CHIP TYPE CARBON RESISTOR	RN72K1J-221JE	1	435032214R1
R7104	CHIP TYPE CARBON RESISTOR	RN72K1J-470JE	1	435034704R1
R7105	CHIP RESISTOR NETWORK	MNR04MRAPJ470	1	43464747004R2

R7105 or	CHIP RESISTOR NETWORK	YCN104-470-JK	( 1)	43464C47004R1	
R7106	CHIP TYPE CARBON RESISTOR	RN72K1J-101JE	1	435031014R1	
R7107	CHIP TYPE CARBON RESISTOR	RN72K1J-101JE	1	435031014R1	
R7108	CHIP RESISTOR NETWORK	MNR04MRAPJ103	1	43464710304R2	
R7108 or	CHIP RESISTOR NETWORK	YCN104-103-JK	( 1)	43464C10304R1	
R7110	CHIP TYPE CARBON RESISTOR	RN72K1J-103JE	1	435031034R1	
R7113	CHIP TYPE CARBON RESISTOR	RN72K1J-470JE	1	435034704R1	
R7121	CHIP TYPE CARBON RESISTOR	RN72K1J-105JE	1	435031054R1	
R7122	CHIP TYPE CARBON RESISTOR	RN72K1J-105JE	1	435031054R1	
R7123	CHIP RESISTOR NETWORK	MNR04MRAPJ221	1	43464722104R2	
R7123 or	CHIP RESISTOR NETWORK	YCN104-221-JK	( 1)	43464C22104R1	
R7125	CHIP TYPE CARBON RESISTOR	RN72K1J-473JE	1	435034734R1	
R7132	CHIP TYPE CARBON RESISTOR	RN72K1J-331JE	1	435033314R1	
R7133	CHIP TYPE CARBON RESISTOR	RN72K1J-221JE	1	435032214R1	
R7134	CHIP TYPE CARBON RESISTOR	RN72K1J-221JE	1	435032214R1	
R7135	CHIP TYPE CARBON RESISTOR	RN72K1J-103JE	1	435031034R1	
R7136	CHIP TYPE CARBON RESISTOR	RN72K1J-470JE	1	435034704R1	
R7137	CHIP TYPE CARBON RESISTOR	RN72K1J-221JE	1	435032214R1	
R7138	CHIP TYPE CARBON RESISTOR	RN72K1J-470JE	1	435034704R1	
R7140	CHIP TYPE CARBON RESISTOR	RN72K1J-103JE	1	435031034R1	
R7141	CHIP TYPE CARBON RESISTOR	RN72K1J-103JE	1	435031034R1	
R7142	CHIP TYPE CARBON RESISTOR	RN72K1J-470JE	1	435034704R1	
R7161	CHIP TYPE CARBON RESISTOR	RN72K1J-103JE	1	435031034R1	
R7170	CHIP TYPE CARBON RESISTOR	RN72K1J-102JE	1	435031024R1	
R7171	CHIP TYPE CARBON RESISTOR	RN72K1J-473JE	1	435034734R1	
R7172	CHIP TYPE CARBON RESISTOR	RN72K1J-222JE	1	435032224R1	
R7180	CHIP TYPE CARBON RESISTOR	RN72K1J-272JE	1	435032724R1	
R7181	CHIP TYPE CARBON RESISTOR	RN72K1J-272JE	1	435032724R1	
R7182	CHIP TYPE CARBON RESISTOR	RN72K1J-272JE	1	435032724R1	
R7183	CHIP TYPE CARBON RESISTOR	RN72K1J-272JE	1	435032724R1	
R7184	CHIP TYPE CARBON RESISTOR	RN72K1J-103JE	1	435031034R1	
R7186	CHIP TYPE CARBON RESISTOR	RN72K1J-104JE	1	435031044R1	
R7187	CHIP TYPE CARBON RESISTOR	RN72K1J-104JE	1	435031044R1	
R7188	CHIP TYPE CARBON RESISTOR	RN72K1J-104JE	1	435031044R1	
R7190	CHIP TYPE CARBON RESISTOR	RN72K1J-102JE	1	435031024R1	
R7191	CHIP TYPE CARBON RESISTOR	RN72K1J-473JE	1	435034734R1	
R7192	CHIP TYPE CARBON RESISTOR	RN72K1J-222JE	1	435032224R1	
R7193	CHIP TYPE CARBON RESISTOR	RN72K1J-470JE	1	435034704R1	
R8000	CHIP TYPE CARBON RESISTOR	RN72K1J-473JE	1	435034734R1	
R8001	CHIP TYPE CARBON RESISTOR	RN72K1J-102JE	1	435031024R1	
R8002	CHIP TYPE CARBON RESISTOR	RN72K1J-470JE	1	435034704R1	
R8003	CHIP TYPE CARBON RESISTOR	RN72K1J-103JE	1	435031034R1	
R8004	CHIP TYPE CARBON RESISTOR	RN72K1J-470JE	1	435034704R1	
R8005	CHIP TYPE CARBON RESISTOR	RN72K1J-472JE	1	435034724R1	
R8006	CHIP TYPE CARBON RESISTOR	RN72K1J-101JE	1	435031014R1	
R8007	CHIP TYPE CARBON RESISTOR	RN72K1J-470JE	1	435034704R1	
R8008	CHIP TYPE CARBON RESISTOR	RN72K1J-472JE	1	435034724R1	
R8009	CHIP TYPE CARBON RESISTOR	RN72K1J-101JE	1	435031014R1	
R8010	CHIP TYPE CARBON RESISTOR	RN72K1J-105JE	1	435031054R1	
R8011	CHIP TYPE CARBON RESISTOR	RN72K1J-473JE	1	435034734R1	
R8012	CHIP TYPE CARBON RESISTOR	RN72K1J-473JE	1	435034734R1	
R8013	CHIP TYPE CARBON RESISTOR	RN72K1J-473JE	1	435034734R1	
R8014	CHIP TYPE CARBON RESISTOR	RN72K1J-102JE	1	435031024R1	
R8015	CHIP TYPE CARBON RESISTOR	RN72K1J-103JE	1	435031034R1	
R8016	CHIP TYPE CARBON RESISTOR	RN72K1J-102JE	1	435031024R1	
R8017	CHIP TYPE CARBON RESISTOR	RN72K1J-103JE	1	435031034R1	
R8018	CHIP TYPE CARBON RESISTOR	RN72K1J-102JE	1	435031024R1	
R8019	CHIP TYPE CARBON RESISTOR	RN72K1J-103JE	1	435031034R1	
R8020	CHIP RESISTOR NETWORK	MNR04MRAPJ222	1	43464722204R2	<b>N</b>
R8020 or	CHIP RESISTOR NETWORK	YCN104-222-JK	( 1)	43464C22204R1	
R8021	CHIP TYPE CARBON RESISTOR	RN72K1J-182JE	1	435031824R1	
R8022	CHIP TYPE CARBON RESISTOR	RN72K1J-182JE	1	435031824R1	

R8023	CHIP TYPE CARBON RESISTOR	RN72K1J-100JE	1	435031004R1	
R8024	CHIP TYPE CARBON RESISTOR	RN72K1J-473JE	1	435034734R1	
R8025	CHIP TYPE CARBON RESISTOR	RN72K1J-560JE	1	435035604R1	
R8026	CHIP TYPE CARBON RESISTOR	RN72K1J-560JE	1	435035604R1	
R8027	CHIP TYPE CARBON RESISTOR	RN72K1J-472JE	1	435034724R1	
R8028	CHIP TYPE CARBON RESISTOR	RN72K1J-103JE	1	435031034R1	
R8029	CHIP TYPE CARBON RESISTOR	RN72K1J-103JE	1	435031034R1	
R8030	CHIP TYPE CARBON RESISTOR	RN72K1J-473JE	1	435034734R1	
R8031	CHIP TYPE CARBON RESISTOR	RN72K1J-103JE	1	435031034R1	
R8032	CHIP TYPE CARBON RESISTOR	RN72K1J-103JE	1	435031034R1	
R8033	CHIP TYPE CARBON RESISTOR	RN72K1J-000JE	1	435030004R1	
R8034	CHIP TYPE CARBON RESISTOR	RN72K1J-103JE	1	435031034R1	
R8035	CHIP TYPE CARBON RESISTOR	RN72K1J-000JE	1	435030004R1	
R8037	CHIP TYPE CARBON RESISTOR	RN72K1J-102JE	1	435031024R1	
R8038	CHIP TYPE CARBON RESISTOR	RN72K1J-102JE	1	435031024R1	
R8075	CHIP TYPE CARBON RESISTOR	RN72K1J-473JE	1	435034734R1	
R8204	CHIP TYPE CARBON RESISTOR	RN72K1J-330JE	1	435033304R1	
R8208	CHIP TYPE CARBON RESISTOR	RN72K1J-560JE	1	435035604R1	
R8209	CHIP TYPE CARBON RESISTOR	RN72K1J-472JE	1	435034724R1	
R8215	CHIP TYPE CARBON RESISTOR	RN72K1J-560JE	1	435035604R1	
R8218	CHIP TYPE CARBON RESISTOR	RN72K1J-560JE	1	435035604R1	
R8220	CHIP TYPE CARBON RESISTOR	RN72K1J-821JE	1	435038214R1	
R8221	CHIP TYPE CARBON RESISTOR	RN72K1J-821JE	1	435038214R1	
R8223	CHIP TYPE CARBON RESISTOR	RN72K1J-821JE	1	435038214R1	
R8225	CHIP TYPE CARBON RESISTOR	RN72K1J-221JE	1	435032214R1	
R8226	CHIP TYPE CARBON RESISTOR	RN72K1J-221JE	1	435032214R1	
R8228	CHIP TYPE CARBON RESISTOR	RN72K1J-221JE	1	435032214R1	
R8233	CHIP TYPE CARBON RESISTOR	RN72K1J-000JE	1	435030004R1	
R8237	CHIP TYPE CARBON RESISTOR	RN72K1J-105JE	1	435031054R1	
R8238	CHIP TYPE CARBON RESISTOR	RN72K1J-331JE	1	435033314R1	
R8240	CHIP TYPE CARBON RESISTOR	RN72K1J-681JE	1	435036814R1	
R8243	CHIP TYPE CARBON RESISTOR	RN72K1J-681JE	1	435036814R1	
R8244	CHIP TYPE CARBON RESISTOR	RN72K1J-330JE	1	435033304R1	
R8300	CHIP TYPE CARBON RESISTOR	RN72K1J-220JE	1	435032204R1	
R8301	CHIP TYPE CARBON RESISTOR	RN72K1J-220JE	1	435032204R1	
R8302	CHIP TYPE CARBON RESISTOR	RN72K1J-103JE	1	435031034R1	
R8303	CHIP TYPE CARBON RESISTOR	RN72K1J-562JE	1	435035624R1	
R8304	CHIP TYPE CARBON RESISTOR	RN72K1J-472JE	1	435034724R1	
R8306	CHIP TYPE CARBON RESISTOR	RN72K1J-562JE	1	435035624R1	
R8307	CHIP TYPE CARBON RESISTOR	RN72K1J-472JE	1	435034724R1	
R8308	CHIP TYPE CARBON RESISTOR	RN72K1J-562JE	1	435035624R1	
R8312	CHIP TYPE CARBON RESISTOR	RN72K1J-100JE	1	435031004R1	
R8317	CHIP TYPE CARBON RESISTOR	RN72K1J-100JE	1	435031004R1	
R8318	CHIP RESISTOR NETWORK	MNR04MRAPJ222	1	43464722204R2	N
R8318 or	CHIP RESISTOR NETWORK	YCN104-222-JK	( 1 )	43464C22204R1	
R8319	CHIP TYPE CARBON RESISTOR	RN72K1J-100JE	1	435031004R1	
R8320	CHIP TYPE CARBON RESISTOR	RN72K1J-100JE	1	435031004R1	
R8321	CHIP TYPE CARBON RESISTOR	RN72K1J-330JE	1	435033304R1	
R8322	CHIP TYPE CARBON RESISTOR	RN72K1J-330JE	1	435033304R1	
R8323	CHIP TYPE CARBON RESISTOR	RN72K1J-330JE	1	435033304R1	
R8324	CHIP TYPE CARBON RESISTOR	RN72K1J-330JE	1	435033304R1	
R8325	CHIP TYPE CARBON RESISTOR	RN72K1J-000JE	1	435030004R1	
R8334	CHIP TYPE CARBON RESISTOR	RN72K1J-000JE	1	435030004R1	
R8335	CHIP TYPE CARBON RESISTOR	RN72K1J-330JE	1	435033304R1	
R8336	CHIP TYPE CARBON RESISTOR	RN72K1J-330JE	1	435033304R1	
R8338	CHIP TYPE CARBON RESISTOR	RN72K1J-330JE	1	435033304R1	
R8339	CHIP TYPE CARBON RESISTOR	RN72K1J-330JE	1	435033304R1	
R8342	CHIP RESISTOR NETWORK	MNR04MRAPJ220	1	43464722004R2	
R8342 or	CHIP RESISTOR NETWORK	YCN104-220-JK	( 1 )	43464C22004R1	
R8343	CHIP RESISTOR NETWORK	MNR04MRAPJ220	1	43464722004R2	
R8343 or	CHIP RESISTOR NETWORK	YCN104-220-JK	( 1 )	43464C22004R1	
R8346	CHIP TYPE CARBON RESISTOR	RN72K1J-220JE	1	435032204R1	

R8350	CHIP TYPE CARBON RESISTOR	RN72K1J-100JE	1	435031004R1
R8353	CHIP TYPE CARBON RESISTOR	RN72K1J-100JE	1	435031004R1
R8354	CHIP TYPE CARBON RESISTOR	RN72K1J-100JE	1	435031004R1
R8355	CHIP TYPE CARBON RESISTOR	RN72K1J-100JE	1	435031004R1
R8356	CHIP TYPE CARBON RESISTOR	RN72K1J-473JE	1	435034734R1
R8357	CHIP TYPE CARBON RESISTOR	RN72K1J-101JE	1	435031014R1
R8358	CHIP TYPE CARBON RESISTOR	RN72K1J-102JE	1	435031024R1
R8359	CHIP TYPE CARBON RESISTOR	RN72K1J-124JE	1	435031244R1
R8361	CHIP TYPE CARBON RESISTOR	RN72K1J-473JE	1	435034734R1
R8362	CHIP TYPE CARBON RESISTOR	RN72K1J-100JE	1	435031004R1
R8363	CHIP RESISTOR NETWORK	MNR04MRAPJ330	1	43464733004R2
R8363 or	CHIP RESISTOR NETWORK	YCN104-330-JK	( 1 )	43464C33004R1
R8365	CHIP TYPE CARBON RESISTOR	RN72K1J-103JE	1	435031034R1
R8372	CHIP TYPE CARBON RESISTOR	RN72K1J-100JE	1	435031004R1
R8373	CHIP TYPE CARBON RESISTOR	RN72K1J-100JE	1	435031004R1
R8374	CHIP TYPE CARBON RESISTOR	RN72K1J-100JE	1	435031004R1
R8400	CHIP RESISTOR NETWORK	MNR04MRAPJ103	1	43464710304R2
R8400 or	CHIP RESISTOR NETWORK	YCN104-103-JK	( 1 )	43464C10304R1
R8401	CHIP TYPE CARBON RESISTOR	RN72K1J-103JE	1	435031034R1
R8402	CHIP RESISTOR NETWORK	MNR04MRAPJ470	1	43464747004R2
R8402 or	CHIP RESISTOR NETWORK	YCN104-470-JK	( 1 )	43464C47004R1
R8403	CHIP TYPE CARBON RESISTOR	RN72K1J-473JE	1	435034734R1
R8405	CHIP TYPE CARBON RESISTOR	RN72K1J-470JE	1	435034704R1
R8406	CHIP TYPE CARBON RESISTOR	RN72K1J-101JE	1	435031014R1
R8407	CHIP TYPE CARBON RESISTOR	RN72K1J-470JE	1	435034704R1
R8408	CHIP TYPE CARBON RESISTOR	RN72K1J-470JE	1	435034704R1
R8413	CHIP TYPE CARBON RESISTOR	RN72K1J-470JE	1	435034704R1
R8414	CHIP TYPE CARBON RESISTOR	RN72K1J-470JE	1	435034704R1
R8415	CHIP TYPE CARBON RESISTOR	RN72K1J-470JE	1	435034704R1
R8416	CHIP TYPE CARBON RESISTOR	RN72K1J-101JE	1	435031014R1
R8417	CHIP TYPE CARBON RESISTOR	RN72K1J-105JE	1	435031054R1
R8418	CHIP TYPE CARBON RESISTOR	RN72K1J-470JE	1	435034704R1
R8419	CHIP TYPE CARBON RESISTOR	RN72K1J-470JE	1	435034704R1
R8420	CHIP TYPE CARBON RESISTOR	RN72K1J-470JE	1	435034704R1
R8421	CHIP TYPE CARBON RESISTOR	RN72K1J-103JE	1	435031034R1
R8422	CHIP TYPE CARBON RESISTOR	RN72K1J-101JE	1	435031014R1
R8423	CHIP TYPE CARBON RESISTOR	RN72K1J-332JE	1	435033324R1
R8424	CHIP TYPE CARBON RESISTOR	RN72K1J-332JE	1	435033324R1
R8425	CHIP TYPE CARBON RESISTOR	RN72K1J-470JE	1	435034704R1
R8426	CHIP TYPE CARBON RESISTOR	RN72K1J-470JE	1	435034704R1
R8427	CHIP TYPE CARBON RESISTOR	RN72K1J-100JE	1	435031004R1
R8429	CHIP TYPE CARBON RESISTOR	RN72K1J-470JE	1	435034704R1
R8430	CHIP TYPE CARBON RESISTOR	RN72K1J-470JE	1	435034704R1
R8431	CHIP TYPE CARBON RESISTOR	RN72K1J-470JE	1	435034704R1
R8432	CHIP TYPE CARBON RESISTOR	RN72K1J-470JE	1	435034704R1
R8437	CHIP TYPE CARBON RESISTOR	RN72K1J-473JE	1	435034734R1
R8438	CHIP TYPE CARBON RESISTOR	RN72K1J-220JE	1	435032204R1
R8439	CHIP TYPE CARBON RESISTOR	RN72K1J-220JE	1	435032204R1
R8440	CHIP TYPE CARBON RESISTOR	RN72K1J-220JE	1	435032204R1
R8441	CHIP TYPE CARBON RESISTOR	RN72K1J-220JE	1	435032204R1
R8442	CHIP TYPE CARBON RESISTOR	RN72K1J-220JE	1	435032204R1
R8443	CHIP TYPE CARBON RESISTOR	RN72K1J-220JE	1	435032204R1
R8444	CHIP TYPE CARBON RESISTOR	RN72K1J-221JE	1	435032214R1
R8445	CHIP TYPE CARBON RESISTOR	RN72K1J-220JE	1	435032204R1
R8446	CHIP TYPE CARBON RESISTOR	RN72K1J-472JE	1	435034724R1
R8447	CHIP TYPE CARBON RESISTOR	RN72K1J-102JE	1	435031024R1
R8448	CHIP TYPE CARBON RESISTOR	RN72K1J-103JE	1	435031034R1
R8449	CHIP TYPE CARBON RESISTOR	RN72K1J-182JE	1	435031824R1
R8450	CHIP TYPE CARBON RESISTOR	RN72K1J-182JE	1	435031824R1
R8451	CHIP TYPE CARBON RESISTOR	RN72K1J-000JE	1	435030004R1
R8452	CHIP TYPE CARBON RESISTOR	RN72K1J-103FE	1	435031032R1
R8453	CHIP TYPE CARBON RESISTOR	RN72K1J-223FE	1	435032232R1

R8458	CHIP TYPE CARBON RESISTOR	RN72K1J-100JE	1	435031004R1
R8459	CHIP TYPE CARBON RESISTOR	RN72K1J-560JE	1	435035604R1
R8461	CHIP TYPE CARBON RESISTOR	RN72K1J-560JE	1	435035604R1
R8462	CHIP TYPE CARBON RESISTOR	RN72K1J-473JE	1	435034734R1
R8463	CHIP TYPE CARBON RESISTOR	RN72K1J-470JE	1	435034704R1
R8464	CHIP RESISTOR NETWORK	MNR04MRAPJ470	1	43464747004R2
R8464 or	CHIP RESISTOR NETWORK	YCN104-470-JK	(1)	43464C47004R1
R8465	CHIP RESISTOR NETWORK	MNR04MRAPJ101	1	43464710104R2
R8465 or	CHIP RESISTOR NETWORK	YCN104-101-JK	(1)	43464C10104R1
R8600	CHIP TYPE CARBON RESISTOR	RN72K1J-000JE	1	435030004R1
R8603	CHIP TYPE CARBON RESISTOR	RN72K1J-473JE	1	435034734R1
R8604	CHIP TYPE CARBON RESISTOR	RN72K1J-473JE	1	435034734R1
R8605	CHIP TYPE CARBON RESISTOR	RN72K1J-100JE	1	435031004R1
R8606	CHIP TYPE CARBON RESISTOR	RN72K1J-000JE	1	435030004R1
R8613	CHIP TYPE CARBON RESISTOR	RN72K1J-473JE	1	435034734R1
R8614	CHIP TYPE CARBON RESISTOR	RN72K1J-473JE	1	435034734R1
R8615	CHIP TYPE CARBON RESISTOR	RN72K1J-100JE	1	435031004R1
R8623	CHIP TYPE CARBON RESISTOR	RN72K1J-473JE	1	435034734R1
R8624	CHIP TYPE CARBON RESISTOR	RN72K1J-473JE	1	435034734R1
R8625	CHIP TYPE CARBON RESISTOR	RN72K1J-100JE	1	435031004R1
R8633	CHIP TYPE CARBON RESISTOR	RN72K1J-473JE	1	435034734R1
R8634	CHIP TYPE CARBON RESISTOR	RN72K1J-473JE	1	435034734R1
R8635	CHIP TYPE CARBON RESISTOR	RN72K1J-100JE	1	435031004R1
R8645	CHIP TYPE CARBON RESISTOR	RN72K1J-100JE	1	435031004R1
R8663	CHIP TYPE CARBON RESISTOR	RN72K1J-473JE	1	435034734R1
R8664	CHIP TYPE CARBON RESISTOR	RN72K1J-473JE	1	435034734R1
R8665	CHIP TYPE CARBON RESISTOR	RN72K1J-100JE	1	435031004R1
R8702	CHIP RESISTOR NETWORK	MNR04MRAPJ221	1	43464722104R2
R8702 or	CHIP RESISTOR NETWORK	YCN104-221-JK	(1)	43464C22104R1
R8703	CHIP TYPE CARBON RESISTOR	RN72K1J-103JE	1	435031034R1
R8704	CHIP RESISTOR NETWORK	MNR04MRAPJ470	1	43464747004R2
R8704 or	CHIP RESISTOR NETWORK	YCN104-470-JK	(1)	43464C47004R1
R8705	CHIP TYPE CARBON RESISTOR	RN72K1J-473JE	1	435034734R1
R8706	CHIP TYPE CARBON RESISTOR	RN72K1J-101JE	1	435031014R1
R8707	CHIP RESISTOR NETWORK	MNR04MRAPJ103	1	43464710304R2
R8707 or	CHIP RESISTOR NETWORK	YCN104-103-JK	(1)	43464C10304R1
R8708	CHIP TYPE CARBON RESISTOR	RN72K1J-101JE	1	435031014R1
R8709	CHIP TYPE CARBON RESISTOR	RN72K1J-470JE	1	435034704R1
R8710	CHIP TYPE CARBON RESISTOR	RN72K1J-102JE	1	435031024R1
R8711	CHIP TYPE CARBON RESISTOR	RN72K1J-103JE	1	435031034R1
R8712	CHIP TYPE CARBON RESISTOR	RN72K1J-470JE	1	435034704R1
R8713	CHIP TYPE CARBON RESISTOR	RN72K1J-101JE	1	435031014R1
R8714	CHIP TYPE CARBON RESISTOR	RN72K1J-103JE	1	435031034R1
R8715	CHIP TYPE CARBON RESISTOR	RN72K1J-103JE	1	435031034R1
R8716	CHIP TYPE CARBON RESISTOR	RN72K1J-332JE	1	435033324R1
R8717	CHIP TYPE CARBON RESISTOR	RN72K1J-332JE	1	435033324R1
R8718	CHIP TYPE CARBON RESISTOR	RN72K1J-222JE	1	435032224R1
R8719	CHIP TYPE CARBON RESISTOR	RN72K1J-222JE	1	435032224R1
R8720	CHIP TYPE CARBON RESISTOR	RN72K1J-103JE	1	435031034R1
R8721	CHIP RESISTOR NETWORK	MNR04MRAPJ470	1	43464747004R2
R8721 or	CHIP RESISTOR NETWORK	YCN104-470-JK	(1)	43464C47004R1
R8723	CHIP TYPE CARBON RESISTOR	RN72K1J-472JE	1	435034724R1
R8724	CHIP TYPE CARBON RESISTOR	RN72K1J-473JE	1	435034734R1
R8725	CHIP TYPE CARBON RESISTOR	RN72K1J-470JE	1	435034704R1
R8726	CHIP TYPE CARBON RESISTOR	RN72K1J-103JE	1	435031034R1
R8727	CHIP RESISTOR NETWORK	MNR04MRAPJ221	1	43464722104R2
R8727 or	CHIP RESISTOR NETWORK	YCN104-221-JK	(1)	43464C22104R1
R8728	CHIP TYPE CARBON RESISTOR	RN72K1J-103JE	1	435031034R1
R8729	CHIP TYPE CARBON RESISTOR	RN72K1J-221JE	1	435032214R1
R8730	CHIP TYPE CARBON RESISTOR	RN72K1J-470JE	1	435034704R1
R8731	CHIP RESISTOR NETWORK	MNR04MRAPJ103	1	43464710304R2
R8731 or	CHIP RESISTOR NETWORK	YCN104-103-JK	(1)	43464C10304R1

R8732	CHIP TYPE CARBON RESISTOR	RN72K1J-221JE	1	435032214R1
R8733	CHIP TYPE CARBON RESISTOR	RN72K1J-105JE	1	435031054R1
R8734	CHIP TYPE CARBON RESISTOR	RN72K1J-470JE	1	435034704R1
R8735	CHIP TYPE CARBON RESISTOR	RN72K1J-221JE	1	435032214R1
R8736	CHIP TYPE CARBON RESISTOR	RN72K1J-102JE	1	435031024R1
R8737	CHIP TYPE CARBON RESISTOR	RN72K1J-472JE	1	435034724R1
R8738	CHIP TYPE CARBON RESISTOR	RN72K1J-103JE	1	435031034R1
R8739	CHIP TYPE CARBON RESISTOR	RN72K1J-102JE	1	435031024R1
R8740	CHIP TYPE CARBON RESISTOR	RN72K1J-103JE	1	435031034R1
R8741	CHIP TYPE CARBON RESISTOR	RN72K1J-102JE	1	435031024R1
R8742	CHIP TYPE CARBON RESISTOR	RN72K1J-103JE	1	435031034R1
R8743	CHIP TYPE CARBON RESISTOR	RN72K1J-103JE	1	435031034R1
R8744	CHIP TYPE CARBON RESISTOR	RN72K1J-470JE	1	435034704R1
R8745	CHIP TYPE CARBON RESISTOR	RN72K1J-103JE	1	435031034R1
R8746	CHIP TYPE CARBON RESISTOR	RN72K1J-470JE	1	435034704R1
R8747	CHIP TYPE CARBON RESISTOR	RN72K1J-105JE	1	435031054R1
R8748	CHIP TYPE CARBON RESISTOR	RN72K1J-470JE	1	435034704R1
R8749	CHIP TYPE CARBON RESISTOR	RN72K1J-103JE	1	435031034R1
R8750	CHIP TYPE CARBON RESISTOR	RN72K1J-470JE	1	435034704R1
R8751	CHIP TYPE CARBON RESISTOR	RN72K1J-103JE	1	435031034R1
R8752	CHIP RESISTOR NETWORK	MNR04MRAPJ101	1	43464710104R2
R8752 or	CHIP RESISTOR NETWORK	YCN104-101-JK	(1)	43464C10104R1
R8753	CHIP RESISTOR NETWORK	MNR04MRAPJ470	1	43464747004R2
R8753 or	CHIP RESISTOR NETWORK	YCN104-470-JK	(1)	43464C47004R1
R8754	CHIP TYPE CARBON RESISTOR	RN72K1J-470JE	1	435034704R1
R8755	CHIP TYPE CARBON RESISTOR	RN72K1J-103JE	1	435031034R1
R8756	CHIP TYPE CARBON RESISTOR	RN72K1J-470JE	1	435034704R1
R8757	CHIP RESISTOR NETWORK	MNR04MRAPJ101	1	43464710104R2
R8757 or	CHIP RESISTOR NETWORK	YCN104-101-JK	(1)	43464C10104R1
R8758	CHIP TYPE CARBON RESISTOR	RN72K1J-103JE	1	435031034R1
R8759	CHIP TYPE CARBON RESISTOR	RN72K1J-103JE	1	435031034R1
R8760	CHIP TYPE CARBON RESISTOR	RN72K1J-103JE	1	435031034R1
R8790	CHIP TYPE CARBON RESISTOR	RN72K1J-101JE	1	435031014R1
R8791	CHIP TYPE CARBON RESISTOR	RN72K1J-101JE	1	435031014R1
R8900	CHIP TYPE CARBON RESISTOR	RN72K1J-472JE	1	435034724R1
R8901	CHIP TYPE CARBON RESISTOR	RN72K1J-103JE	1	435031034R1
R8902	CHIP TYPE CARBON RESISTOR	RN72K1J-102JE	1	435031024R1
R8903	CHIP TYPE CARBON RESISTOR	RN72K1J-102JE	1	435031024R1
R8922	CHIP TYPE CARBON RESISTOR	RN72K1J-473JE	1	435034734R1
R8923	CHIP TYPE CARBON RESISTOR	RN72K1J-332JE	1	435033324R1
R8924	CHIP TYPE CARBON RESISTOR	RN72K1J-682FE	1	435036822R1
R8925	CHIP TYPE CARBON RESISTOR	RN72K1J-332FE	1	435033322R1
R8926	CHIP TYPE CARBON RESISTOR	RN72K1J-103FE	1	435031032R1
R8932	CHIP TYPE CARBON RESISTOR	RN72K1J-473JE	1	435034734R1
R8933	CHIP TYPE CARBON RESISTOR	RN72K1J-332JE	1	435033324R1
R8934	CHIP TYPE CARBON RESISTOR	RN72K1J-272FE	1	435032722R1
R8935	CHIP TYPE CARBON RESISTOR	RN72K1J-222FE	1	435032222R1
R8936	CHIP TYPE CARBON RESISTOR	RN72K1J-103FE	1	435031032R1
R8939	CHIP TYPE CARBON RESISTOR	RN72K1J-102JE	1	435031024R1
R8942	CHIP TYPE CARBON RESISTOR	RN72K1J-473JE	1	435034734R1
R8943	CHIP TYPE CARBON RESISTOR	RN72K1J-472JE	1	435034724R1
R8944	CHIP TYPE CARBON RESISTOR	RN72K1J-103FE	1	435031032R1
R8946	CHIP TYPE CARBON RESISTOR	RN72K1J-103FE	1	435031032R1
R8949	CHIP TYPE CARBON RESISTOR	RN72K1J-104JE	1	435031044R1
R8952	CHIP TYPE CARBON RESISTOR	RN72K1J-473JE	1	435034734R1
R8953	CHIP TYPE CARBON RESISTOR	RN72K1J-682JE	1	435036824R1
R8954	CHIP TYPE CARBON RESISTOR	RN72K1J-333FE	1	435033332R1
R8955	CHIP TYPE CARBON RESISTOR	RN72K1J-124FE	1	435031242R1
R8956	CHIP TYPE CARBON RESISTOR	RN72K1J-103FE	1	435031032R1
R8958	CHIP TYPE CARBON RESISTOR	RN72K1J-473JE	1	435034734R1
R8959	CHIP TYPE CARBON RESISTOR	RN72K1J-473JE	1	435034734R1
R8962	CHIP TYPE CARBON RESISTOR	RN72K1J-473JE	1	435034734R1



R8963	CHIP TYPE CARBON RESISTOR	RN72K1J-103JE	1	435031034R1
R8964	CHIP TYPE CARBON RESISTOR	RN72K1J-563FE	1	435035632R1
R8965	CHIP TYPE CARBON RESISTOR	RN72K1J-274JE	1	435032744R1
R8966	CHIP TYPE CARBON RESISTOR	RN72K1J-103FE	1	435031032R1
R8968	CHIP TYPE CARBON RESISTOR	RN72K1J-473JE	1	435034734R1
R8969	CHIP TYPE CARBON RESISTOR	RN72K1J-473JE	1	435034734R1
R8970	CHIP TYPE CARBON RESISTOR	RN72K1J-472JE	1	435034724R1
R8971	CHIP TYPE CARBON RESISTOR	RN72K1J-472JE	1	435034724R1
R8972	CHIP TYPE CARBON RESISTOR	RN72K1J-473JE	1	435034734R1
R8976	CHIP TYPE CARBON RESISTOR	RN72K1J-105JE	1	435031054R1
R8982	CHIP TYPE CARBON RESISTOR	RN72K1J-104JE	1	435031044R1
R8983	CHIP TYPE CARBON RESISTOR	RN72K1J-473JE	1	435034734R1
<b>[SW TRM]</b>				
P212B	SOCKET	NSCT-17P2480	1	25052583R2
P2200B	PLUG	NPLG-7P920	1	25055967R2
P2201B	SOCKET	40FMN-SMT-A-TF	1	25052857R2
P3100	SOCKET	UJA01SB4090-72R	1	25053533R2
P3103	SOCKET	NSCT-9P2472	1	25052575R2
P3104	SOCKET	29-01000PH53-1	1	25053526R3
P7001A	SOCKET	IMSA-9618S-13A	1	25053338R2
P7002A	SOCKET	NSCT-27P2490	1	25052593R2
P8001	SOCKET	51U019S-3HFDN-BD-SM	1	25053549R3
P8001 or	SOCKET	HDMI(47266-4101)	(1)	25053389R3
P8001 or	SOCKET	TCX3423-311387	(1)	25060513R3
P8002A	PLUG(B to B)	IMSA-9850B-24Y	1	25056207R2
P8003A	PLUG(B to B)	IMSA-9850B-24Y	1	25056207R2
P8021	SOCKET	51U019S-3HFDN-BD-SM	1	25053549R3
P8021 or	SOCKET	HDMI(47266-4101)	(1)	25053389R3
P8021 or	SOCKET	TCX3423-311387	(1)	25060513R3
P8601	SOCKET	TCX3281-110187	1	25053520R3
P8611	SOCKET	51U019S-3HFDN-BD-SM	1	25053549R3
P8611 or	SOCKET	HDMI(47266-4101)	(1)	25053389R3
P8611 or	SOCKET	TCX3423-311387	(1)	25060513R3
P8621	SOCKET	51U019S-3HFDN-BD-SM	1	25053549R3
P8621 or	SOCKET	HDMI(47266-4101)	(1)	25053389R3
P8621 or	SOCKET	TCX3423-311387	(1)	25060513R3
P8631	SOCKET	51U019S-3HFDN-BD-SM	1	25053549R3
P8631 or	SOCKET	HDMI(47266-4101)	(1)	25053389R3
P8631 or	SOCKET	TCX3423-311387	(1)	25060513R3
P8641	SOCKET	51U019S-3HFDN-BD-SM	1	25053549R3
P8641 or	SOCKET	HDMI(47266-4101)	(1)	25053389R3
P8641 or	SOCKET	TCX3423-311387	(1)	25060513R3
P8651	SOCKET	51U019S-3HFDN-BD-SM	1	25053549R3
P8651 or	SOCKET	HDMI(47266-4101)	(1)	25053389R3
P8651 or	SOCKET	TCX3423-311387	(1)	25060513R3
P8661	SOCKET	51U019S-3HFDN-BD-SM	1	25053549R3
P8661 or	SOCKET	HDMI(47266-4101)	(1)	25053389R3
P8661 or	SOCKET	TCX3423-311387	(1)	25060513R3
P8671	SOCKET	51U019S-3HFDN-BD-SM	1	25053549R3
P8671 or	SOCKET	HDMI(47266-4101)	(1)	25053389R3
P8671 or	SOCKET	TCX3423-311387	(1)	25060513R3
RL8400	RELAY	NRL-2P1A-DC4.5V-203	1	25065721R2

U005

BATRM-1804-1A

: NSP

CIRCUIT NO	PART NAME	DESCRIPTION	Q'TY	PART NO. (SN)	REMARKS
<b>[SEMI CONDUCTOR]</b>					
D5201	CHIP TYPE DIODE	DA2J10100	1	223303R2	
D5201 or	CHIP TYPE DIODE	1SS352	(1)	223234R2	

D5202	CHIP TYPE DIODE	DA2J10100	1	223303R2
D5202 or	CHIP TYPE DIODE	1SS352	(1)	223234R2
D5203	CHIP TYPE DIODE	DA2J10100	1	223303R2
D5203 or	CHIP TYPE DIODE	1SS352	(1)	223234R2
D5204	CHIP TYPE DIODE	DA2J10100	1	223303R2
D5204 or	CHIP TYPE DIODE	1SS352	(1)	223234R2
D5205	CHIP TYPE DIODE	DA2J10100	1	223303R2
D5205 or	CHIP TYPE DIODE	1SS352	(1)	223234R2
D5206	CHIP TYPE DIODE	DA2J10100	1	223303R2
D5206 or	CHIP TYPE DIODE	1SS352	(1)	223234R2
D5207	CHIP TYPE DIODE	DA2J10100	1	223303R2
D5207 or	CHIP TYPE DIODE	1SS352	(1)	223234R2
D5209	CHIP TYPE DIODE	DA2J10100	1	223303R2
D5209 or	CHIP TYPE DIODE	1SS352	(1)	223234R2
D5210	CHIP TYPE DIODE	DA2J10100	1	223303R2
D5210 or	CHIP TYPE DIODE	1SS352	(1)	223234R2
D5217	CHIP TYPE DIODE	DA2J10100	1	223303R2
D5217 or	CHIP TYPE DIODE	1SS352	(1)	223234R2
D5301	CHIP TYPE DIODE	DA2J10100	1	223303R2
D5301 or	CHIP TYPE DIODE	1SS352	(1)	223234R2
D5901	DIODE	D3SBA60	1	22380272F
D5902	DIODE	D3SBA60	1	22380272F
D9303	DIODE	RL1N4003	1	22380260T
D9304	DIODE	RL1N4003	1	22380260T
D9305	DIODE	RL1N4003	1	22380260T
D9306	DIODE	RL1N4003	1	22380260T
D9307	ZENER DIODE	DZ2J220M0L	1	224762200R2
D9307 or	ZENER DIODE	UDZS22B	(1)	224552200R2
D9308	ZENER DIODE	DZ2J220M0L	1	224762200R2
D9308 or	ZENER DIODE	UDZS22B	(1)	224552200R2
Q5001	HYBRID IC	NJM4580CG	1	22242922R2
Q5101	HYBRID IC	NJM4580CG	1	22242922R2
Q5102	HYBRID IC	NJM4580CG	1	22242922R2
Q5103	HYBRID IC	NJM4580CG	1	22242922R2
Q5104	HYBRID IC	NJM4580CG	1	22242922R2
Q5105	HYBRID IC	NJM4580CG	1	22242922R2
Q5106	HYBRID IC	NJM4580CG	1	22242922R2
Q5107	HYBRID IC	NJM4580CG	1	22242922R2
Q5108	HYBRID IC	NJM4580CG	1	22242922R2
Q5109	HYBRID IC	NJM4580CG	1	22242922R2
Q5201	TRANSISTOR	KRC105S	1	2217290R2
Q5201 or	TRANSISTOR	RN1405	(1)	2214500R2
Q5201 or	TRANSISTOR	DTC123JKA	(1)	2216690R2
Q5203	TRANSISTOR	KRC105S	1	2217290R2
Q5203 or	TRANSISTOR	RN1405	(1)	2214500R2
Q5203 or	TRANSISTOR	DTC123JKA	(1)	2216690R2
Q5204	TRANSISTOR	KRC105S	1	2217290R2
Q5204 or	TRANSISTOR	RN1405	(1)	2214500R2
Q5204 or	TRANSISTOR	DTC123JKA	(1)	2216690R2
Q5206	TRANSISTOR	KRC105S	1	2217290R2
Q5206 or	TRANSISTOR	RN1405	(1)	2214500R2
Q5206 or	TRANSISTOR	DTC123JKA	(1)	2216690R2
Q5209	TRANSISTOR	KRC105S	1	2217290R2
Q5209 or	TRANSISTOR	RN1405	(1)	2214500R2
Q5209 or	TRANSISTOR	DTC123JKA	(1)	2216690R2
Q5210	TRANSISTOR	KRC105S	1	2217290R2
Q5210 or	TRANSISTOR	RN1405	(1)	2214500R2
Q5210 or	TRANSISTOR	DTC123JKA	(1)	2216690R2
Q5216	TRANSISTOR	KRC105S	1	2217290R2
Q5216 or	TRANSISTOR	RN1405	(1)	2214500R2
Q5216 or	TRANSISTOR	DTC123JKA	(1)	2216690R2
Q5301	HYBRID IC	NJM4556AM	1	22241414R2

Q5302	TRANSISTOR	KRC105S	1	2217290R2
Q5302 or	TRANSISTOR	RN1405	( 1)	2214500R2
Q5302 or	TRANSISTOR	DTC123JKA	( 1)	2216690R2
Q5901	HYBRID IC	78M12HF(NJM78M12FA)	1	222780125JRC
Q5902	HYBRID IC	79M12HF(NJM79M12FA)	1	222790125JRC
Q5903	HYBRID IC	78M12HF(NJM78M12FA)	1	222780125JRC
Q5904	HYBRID IC	79M12HF(NJM79M12FA)	1	222790125JRC
Q9302	TRANSISTOR	2SC2881-Y	1	2217564AR2
<b>[CAPACITOR]</b>				
C1560	UTSP TYPE ELECTROLYTIC CAPACITOR	CE04W50V 47M(UTSP)	1	397584707AT
C1561	UTSP TYPE ELECTROLYTIC CAPACITOR	CE04W50V 47M(UTSP)	1	397584707AT
C1562	UTSP TYPE ELECTROLYTIC CAPACITOR	CE04W50V 47M(UTSP)	1	397584707AT
C1563	UTSP TYPE ELECTROLYTIC CAPACITOR	CE04W50V 47M(UTSP)	1	397584707AT
C1564	UTSP TYPE ELECTROLYTIC CAPACITOR	CE04W50V 47M(UTSP)	1	397584707AT
C1565	UTSP TYPE ELECTROLYTIC CAPACITOR	CE04W50V 47M(UTSP)	1	397584707AT
C1566	UTSP TYPE ELECTROLYTIC CAPACITOR	CE04W50V 47M(UTSP)	1	397584707AT
C1567	UTSP TYPE ELECTROLYTIC CAPACITOR	CE04W50V 47M(UTSP)	1	397584707AT
C5001	CHIP TYPE CERAMIC CAPACITOR	CC725CH1H-102J1	1	342101024R1
C5002	CHIP TYPE CERAMIC CAPACITOR	CC725CH1H-102J1	1	342101024R1
C5003	CHIP TYPE CERAMIC CAPACITOR	CC725CH1H-221J1	1	342102214R1
C5004	CHIP TYPE CERAMIC CAPACITOR	CC725CH1H-221J1	1	342102214R1
C5005	CHIP TYPE CERAMIC CAPACITOR	CC725CH1H-221J1	1	342102214R1
C5006	CHIP TYPE CERAMIC CAPACITOR	CC725CH1H-221J1	1	342102214R1
C5007	UTSP TYPE ELECTROLYTIC CAPACITOR	CE04W50V 47M(UTSP)	1	397584707AT
C5008	UTSP TYPE ELECTROLYTIC CAPACITOR	CE04W50V 47M(UTSP)	1	397584707AT
C5009	UTSP TYPE ELECTROLYTIC CAPACITOR	CE04W50V 47M(UTSP)	1	397584707AT
C5010	UTSP TYPE ELECTROLYTIC CAPACITOR	CE04W50V 47M(UTSP)	1	397584707AT
C5011	UTSP TYPE ELECTROLYTIC CAPACITOR	CE04W50V 47M(UTSP)	1	397584707AT
C5012	UTSP TYPE ELECTROLYTIC CAPACITOR	CE04W50V 47M(UTSP)	1	397584707AT
C5013	UTSP TYPE ELECTROLYTIC CAPACITOR	CE04W25V-220M(UTSP)	1	397552217T
C5014	UTSP TYPE ELECTROLYTIC CAPACITOR	CE04W25V-220M(UTSP)	1	397552217T
C5101	CHIP TYPE CERAMIC CAPACITOR	CC725CH1H-101J1	1	342101014R1
C5102	CHIP TYPE CERAMIC CAPACITOR	CC725CH1H-101J1	1	342101014R1
C5103	CHIP TYPE CERAMIC CAPACITOR	CC725CH1H-101J1	1	342101014R1
C5104	CHIP TYPE CERAMIC CAPACITOR	CC725CH1H-101J1	1	342101014R1
C5105	CHIP TYPE CERAMIC CAPACITOR	CC725CH1H-101J1	1	342101014R1
C5106	CHIP TYPE CERAMIC CAPACITOR	CC725CH1H-101J1	1	342101014R1
C5107	CHIP TYPE CERAMIC CAPACITOR	CC725CH1H-101J1	1	342101014R1
C5108	CHIP TYPE CERAMIC CAPACITOR	CC725CH1H-101J1	1	342101014R1
C5109	CHIP TYPE CERAMIC CAPACITOR	CC725CH1H-101J1	1	342101014R1
C5111	UTSP TYPE ELECTROLYTIC CAPACITOR	CE04W50V 47M(UTSP)	1	397584707AT
C5112	UTSP TYPE ELECTROLYTIC CAPACITOR	CE04W50V 47M(UTSP)	1	397584707AT
C5113	UTSP TYPE ELECTROLYTIC CAPACITOR	CE04W50V 47M(UTSP)	1	397584707AT
C5114	UTSP TYPE ELECTROLYTIC CAPACITOR	CE04W50V 47M(UTSP)	1	397584707AT
C5115	UTSP TYPE ELECTROLYTIC CAPACITOR	CE04W50V 47M(UTSP)	1	397584707AT
C5116	UTSP TYPE ELECTROLYTIC CAPACITOR	CE04W50V 47M(UTSP)	1	397584707AT
C5117	UTSP TYPE ELECTROLYTIC CAPACITOR	CE04W50V 47M(UTSP)	1	397584707AT
C5118	UTSP TYPE ELECTROLYTIC CAPACITOR	CE04W50V 47M(UTSP)	1	397584707AT
C5119	UTSP TYPE ELECTROLYTIC CAPACITOR	CE04W50V 47M(UTSP)	1	397584707AT
C5121	UTSP TYPE ELECTROLYTIC CAPACITOR	CE04W50V-22M(UTSP)	1	397582207AT
C5122	UTSP TYPE ELECTROLYTIC CAPACITOR	CE04W50V-22M(UTSP)	1	397582207AT
C5123	UTSP TYPE ELECTROLYTIC CAPACITOR	CE04W50V-22M(UTSP)	1	397582207AT
C5124	UTSP TYPE ELECTROLYTIC CAPACITOR	CE04W50V-22M(UTSP)	1	397582207AT
C5125	UTSP TYPE ELECTROLYTIC CAPACITOR	CE04W50V-22M(UTSP)	1	397582207AT
C5126	UTSP TYPE ELECTROLYTIC CAPACITOR	CE04W50V-22M(UTSP)	1	397582207AT
C5127	UTSP TYPE ELECTROLYTIC CAPACITOR	CE04W50V-22M(UTSP)	1	397582207AT
C5128	UTSP TYPE ELECTROLYTIC CAPACITOR	CE04W50V-22M(UTSP)	1	397582207AT
C5129	UTSP TYPE ELECTROLYTIC CAPACITOR	CE04W50V-22M(UTSP)	1	397582207AT
C5131	UTSP TYPE ELECTROLYTIC CAPACITOR	CE04W50V-22M(UTSP)	1	397582207AT
C5132	UTSP TYPE ELECTROLYTIC CAPACITOR	CE04W50V-22M(UTSP)	1	397582207AT
C5133	UTSP TYPE ELECTROLYTIC CAPACITOR	CE04W50V-22M(UTSP)	1	397582207AT
C5134	UTSP TYPE ELECTROLYTIC CAPACITOR	CE04W50V-22M(UTSP)	1	397582207AT

C5135	UTSP TYPE ELECTROLYTIC CAPACITOR	CE04W50V-22M(UTSP)	1	397582207AT
C5136	UTSP TYPE ELECTROLYTIC CAPACITOR	CE04W50V-22M(UTSP)	1	397582207AT
C5137	UTSP TYPE ELECTROLYTIC CAPACITOR	CE04W50V-22M(UTSP)	1	397582207AT
C5138	UTSP TYPE ELECTROLYTIC CAPACITOR	CE04W50V-22M(UTSP)	1	397582207AT
C5139	UTSP TYPE ELECTROLYTIC CAPACITOR	CE04W50V-22M(UTSP)	1	397582207AT
C5201	CHIP TYPE CERAMIC CAPACITOR	CC725CH1H-221J1	1	342102214R1
C5202	CHIP TYPE CERAMIC CAPACITOR	CC725CH1H-221J1	1	342102214R1
C5203	CHIP TYPE CERAMIC CAPACITOR	CC725CH1H-221J1	1	342102214R1
C5204	CHIP TYPE CERAMIC CAPACITOR	CC725CH1H-221J1	1	342102214R1
C5205	CHIP TYPE CERAMIC CAPACITOR	CC725CH1H-221J1	1	342102214R1
C5206	CHIP TYPE CERAMIC CAPACITOR	CC725CH1H-221J1	1	342102214R1
C5207	CHIP TYPE CERAMIC CAPACITOR	CC725CH1H-221J1	1	342102214R1
C5209	CHIP TYPE CERAMIC CAPACITOR	CK725B1H-104K1	1	332101045R1
C5210	CHIP TYPE CERAMIC CAPACITOR	CK725B1H-104K1	1	332101045R1
C5211	CHIP TYPE CERAMIC CAPACITOR	CC725CH1H-221J1	1	342102214R1
C5212	CHIP TYPE CERAMIC CAPACITOR	CC725CH1H-221J1	1	342102214R1
C5213	CHIP TYPE CERAMIC CAPACITOR	CC725CH1H-221J1	1	342102214R1
C5214	CHIP TYPE CERAMIC CAPACITOR	CC725CH1H-221J1	1	342102214R1
C5215	CHIP TYPE CERAMIC CAPACITOR	CC725CH1H-221J1	1	342102214R1
C5216	CHIP TYPE CERAMIC CAPACITOR	CC725CH1H-221J1	1	342102214R1
C5217	CHIP TYPE CERAMIC CAPACITOR	CC725CH1H-221J1	1	342102214R1
C5221	UTSP TYPE ELECTROLYTIC CAPACITOR	CE04W25V-220M(UTSP)	1	397552217T
C5222	UTSP TYPE ELECTROLYTIC CAPACITOR	CE04W25V-220M(UTSP)	1	397552217T
C5223	UTSP TYPE ELECTROLYTIC CAPACITOR	CE04W25V-220M(UTSP)	1	397552217T
C5224	UTSP TYPE ELECTROLYTIC CAPACITOR	CE04W25V-220M(UTSP)	1	397552217T
C5225	UTSP TYPE ELECTROLYTIC CAPACITOR	CE04W25V-220M(UTSP)	1	397552217T
C5226	UTSP TYPE ELECTROLYTIC CAPACITOR	CE04W25V-220M(UTSP)	1	397552217T
C5227	UTSP TYPE ELECTROLYTIC CAPACITOR	CE04W25V-220M(UTSP)	1	397552217T
C5228	UTSP TYPE ELECTROLYTIC CAPACITOR	CE04W25V-220M(UTSP)	1	397552217T
C5229	UTSP TYPE ELECTROLYTIC CAPACITOR	CE04W25V-220M(UTSP)	1	397552217T
C5231	UTSP TYPE ELECTROLYTIC CAPACITOR	CE04W25V-220M(UTSP)	1	397552217T
C5232	UTSP TYPE ELECTROLYTIC CAPACITOR	CE04W25V-220M(UTSP)	1	397552217T
C5233	UTSP TYPE ELECTROLYTIC CAPACITOR	CE04W25V-220M(UTSP)	1	397552217T
C5234	UTSP TYPE ELECTROLYTIC CAPACITOR	CE04W25V-220M(UTSP)	1	397552217T
C5235	UTSP TYPE ELECTROLYTIC CAPACITOR	CE04W25V-220M(UTSP)	1	397552217T
C5236	UTSP TYPE ELECTROLYTIC CAPACITOR	CE04W25V-220M(UTSP)	1	397552217T
C5237	UTSP TYPE ELECTROLYTIC CAPACITOR	CE04W25V-220M(UTSP)	1	397552217T
C5238	UTSP TYPE ELECTROLYTIC CAPACITOR	CE04W25V-220M(UTSP)	1	397552217T
C5239	UTSP TYPE ELECTROLYTIC CAPACITOR	CE04W25V-220M(UTSP)	1	397552217T
C5241	CHIP TYPE CERAMIC CAPACITOR	CK725B1H-104K1	1	332101045R1
C5242	CHIP TYPE CERAMIC CAPACITOR	CK725B1H-104K1	1	332101045R1
C5243	CHIP TYPE CERAMIC CAPACITOR	CK725B1H-104K1	1	332101045R1
C5244	CHIP TYPE CERAMIC CAPACITOR	CK725B1H-104K1	1	332101045R1
C5245	CHIP TYPE CERAMIC CAPACITOR	CK725B1H-104K1	1	332101045R1
C5246	CHIP TYPE CERAMIC CAPACITOR	CK725B1H-104K1	1	332101045R1
C5247	CHIP TYPE CERAMIC CAPACITOR	CK725B1H-104K1	1	332101045R1
C5267	CHIP TYPE CERAMIC CAPACITOR	CC725CH1H-221J1	1	342102214R1
C5277	CHIP TYPE CERAMIC CAPACITOR	CC725CH1H-221J1	1	342102214R1
C5287	CHIP TYPE CERAMIC CAPACITOR	CK725B1H-104K1	1	332101045R1
C5301	UTSP TYPE ELECTROLYTIC CAPACITOR	CE04W50V 47M(UTSP)	1	397584707AT
C5302	UTSP TYPE ELECTROLYTIC CAPACITOR	CE04W50V 47M(UTSP)	1	397584707AT
C5303	CHIP TYPE CERAMIC CAPACITOR	CC725CH1H-471J1	1	342104714R1
C5304	CHIP TYPE CERAMIC CAPACITOR	CC725CH1H-471J1	1	342104714R1
C5305	CHIP TYPE CERAMIC CAPACITOR	CC725CH1H-101J1	1	342101014R1
C5306	CHIP TYPE CERAMIC CAPACITOR	CC725CH1H-101J1	1	342101014R1
C5307	UTSP TYPE ELECTROLYTIC CAPACITOR	CE04W25V-220M(UTSP)	1	397552217T
C5308	UTSP TYPE ELECTROLYTIC CAPACITOR	CE04W25V-220M(UTSP)	1	397552217T
C5309	UTSP TYPE ELECTROLYTIC CAPACITOR	CE04W25V-220M(UTSP)	1	397552217T
C5310	UTSP TYPE ELECTROLYTIC CAPACITOR	CE04W25V-220M(UTSP)	1	397552217T
C5311	CHIP TYPE CERAMIC CAPACITOR	CK725B1H-104K1	1	332101045R1
C5901	TF TYPE PLASTIC FILM CAPACITOR	EQQ-V50V-334J	1	374723344T
C5901 or	FILM C	C281H334J20A21A	(1)	376823344T

C5902	TF TYPE PLASTIC FILM CAPACITOR	ECQ-V50V-334J	1	374723344T
C5902 or	FILM C	C281H334J20A21A	( 1)	376823344T
C5903	ELECTROLYTIC CAPACITOR	CE69W35V-8200M(ESMH)	1	3500229A
C5904	ELECTROLYTIC CAPACITOR	CE69W35V-8200M(ESMH)	1	3500229A
C5905	UTSP TYPE ELECTROLYTIC CAPACITOR	CE04W50V-10M(UTSP)	1	397581007AT
C5906	UTSP TYPE ELECTROLYTIC CAPACITOR	CE04W50V-10M(UTSP)	1	397581007AT
C5907	TF TYPE PLASTIC FILM CAPACITOR	ECQ-V50V-334J	1	374723344T
C5907 or	FILM C	C281H334J20A21A	( 1)	376823344T
C5908	TF TYPE PLASTIC FILM CAPACITOR	ECQ-V50V-334J	1	374723344T
C5908 or	FILM C	C281H334J20A21A	( 1)	376823344T
C5909	ELECTROLYTIC CAPACITOR	CE69W35V-8200M(ESMH)	1	3500229A
C5910	ELECTROLYTIC CAPACITOR	CE69W35V-8200M(ESMH)	1	3500229A
C5911	UTSP TYPE ELECTROLYTIC CAPACITOR	CE04W50V-10M(UTSP)	1	397581007AT
C5912	UTSP TYPE ELECTROLYTIC CAPACITOR	CE04W50V-10M(UTSP)	1	397581007AT
C9304	VR TYPE ELECTROLYTIC CAPACITOR	CE04W100V-47M(VR)	1	394694707T
C9305	UTSP TYPE ELECTROLYTIC CAPACITOR	CE04W50V 47M(UTSP)	1	397584707AT
C9306	UTSP TYPE ELECTROLYTIC CAPACITOR	CE04W50V 47M(UTSP)	1	397584707AT
<b>[RESISTOR]</b>				
R1563	CHIP TYPE CARBON RESISTOR	RN72K1J-224JE	1	435032244R1
R1564	CHIP TYPE CARBON RESISTOR	RN72K1J-224JE	1	435032244R1
R1565	CHIP TYPE CARBON RESISTOR	RN72K1J-224JE	1	435032244R1
R1566	CHIP TYPE CARBON RESISTOR	RN72K1J-224JE	1	435032244R1
R1567	CHIP TYPE CARBON RESISTOR	RN72K1J-224JE	1	435032244R1
R5001	CHIP TYPE CARBON RESISTOR	RN72K1J-470JE	1	435034704R1
R5002	CHIP TYPE CARBON RESISTOR	RN72K1J-470JE	1	435034704R1
R5003	CHIP TYPE CARBON RESISTOR	RN72K1J-470JE	1	435034704R1
R5004	CHIP TYPE CARBON RESISTOR	RN72K1J-470JE	1	435034704R1
R5005	CHIP TYPE CARBON RESISTOR	RN72K1J-474JE	1	435034744R1
R5006	CHIP TYPE CARBON RESISTOR	RN72K1J-474JE	1	435034744R1
R5007	CHIP TYPE CARBON RESISTOR	RN72K1J-474JE	1	435034744R1
R5008	CHIP TYPE CARBON RESISTOR	RN72K1J-474JE	1	435034744R1
R5009	CHIP TYPE CARBON RESISTOR	RN72K1J-103JE	1	435031034R1
R5010	CHIP TYPE CARBON RESISTOR	RN72K1J-103JE	1	435031034R1
R5011	CHIP TYPE CARBON RESISTOR	RN72K1J-103JE	1	435031034R1
R5012	CHIP TYPE CARBON RESISTOR	RN72K1J-103JE	1	435031034R1
R5013	CHIP TYPE CARBON RESISTOR	RN72K1J-103JE	1	435031034R1
R5014	CHIP TYPE CARBON RESISTOR	RN72K1J-103JE	1	435031034R1
R5015	CHIP TYPE CARBON RESISTOR	RN72K1J-103JE	1	435031034R1
R5016	CHIP TYPE CARBON RESISTOR	RN72K1J-103JE	1	435031034R1
R5017	CHIP TYPE CARBON RESISTOR	RN72K1J-103JE	1	435031034R1
R5018	CHIP TYPE CARBON RESISTOR	RN72K1J-103JE	1	435031034R1
R5019	CHIP TYPE CARBON RESISTOR	RN72K1J-103JE	1	435031034R1
R5020	CHIP TYPE CARBON RESISTOR	RN72K1J-103JE	1	435031034R1
R5021	CHIP TYPE CARBON RESISTOR	RN72K1J-224JE	1	435032244R1
R5022	CHIP TYPE CARBON RESISTOR	RN72K1J-224JE	1	435032244R1
R5023	CHIP TYPE CARBON RESISTOR	RN72K1J-220JE	1	435032204R1
R5024	CHIP TYPE CARBON RESISTOR	RN72K1J-220JE	1	435032204R1
R5101	CHIP TYPE CARBON RESISTOR	RN72K1J-271JE	1	435032714R1
R5102	CHIP TYPE CARBON RESISTOR	RN72K1J-271JE	1	435032714R1
R5103	CHIP TYPE CARBON RESISTOR	RN72K1J-271JE	1	435032714R1
R5104	CHIP TYPE CARBON RESISTOR	RN72K1J-271JE	1	435032714R1
R5105	CHIP TYPE CARBON RESISTOR	RN72K1J-271JE	1	435032714R1
R5106	CHIP TYPE CARBON RESISTOR	RN72K1J-271JE	1	435032714R1
R5107	CHIP TYPE CARBON RESISTOR	RN72K1J-271JE	1	435032714R1
R5108	CHIP TYPE CARBON RESISTOR	RN72K1J-271JE	1	435032714R1
R5109	CHIP TYPE CARBON RESISTOR	RN72K1J-271JE	1	435032714R1
R5111	CHIP TYPE CARBON RESISTOR	RN72K1J-104JE	1	435031044R1
R5112	CHIP TYPE CARBON RESISTOR	RN72K1J-104JE	1	435031044R1
R5113	CHIP TYPE CARBON RESISTOR	RN72K1J-104JE	1	435031044R1
R5114	CHIP TYPE CARBON RESISTOR	RN72K1J-104JE	1	435031044R1
R5115	CHIP TYPE CARBON RESISTOR	RN72K1J-104JE	1	435031044R1
R5116	CHIP TYPE CARBON RESISTOR	RN72K1J-104JE	1	435031044R1







R5401	CHIP TYPE CARBON RESISTOR	RN72K1J-000JE	1	435030004R1	
R5402	CHIP TYPE CARBON RESISTOR	RN72K1J-000JE	1	435030004R1	
R9301	CHIP TYPE CARBON RESISTOR	RN72K1J-010JE	1	435030104R1	
R9302	CHIP TYPE CARBON RESISTOR	RN72K1J-272JE	1	435032724R1	
R9303	CHIP TYPE CARBON RESISTOR	RN72K1J-333JE	1	435033334R1	
R9304	CHIP TYPE CARBON RESISTOR	RN72K1J-000JE	1	435030004R1	
R9305	CHIP TYPE CARBON RESISTOR	RN72K1J-272JE	1	435032724R1	
<b>[SW TRM]</b>					
F5901	FUSE	T1A-SEUL-T250V	1	252397T	!
F5901A	FUSE LABEL	T1A 250V	1	29392374	!
F5902	FUSE	T1A-SEUL-T250V	1	252397T	!
F5903	FUSE	T1A-SEUL-T250V	1	252397T	!
F5903A	FUSE LABEL	T1A 250V	1	29392374	!
F5904	FUSE	T1A-SEUL-T250V	1	252397T	!
P1008A	SOCKET	IMSA-9142S-24A	1	25053234	
P2203B	SOCKET	NSCT-15P2406	1	25052509	
P4591A	SOCKET	IMSA-9142S-26A	1	25053235	
P4604A	WIRE HARNESS ASSEMBLY	NSAS-26P2327	1	2009991498AUL	N
P4606	WIRE HARNESS ASSEMBLY	NSAS-3P2095	1	2009991284UL	
P4606A	WIRE HOL	CHD-1.5-3	1	25053535	
P4606Aor	WIRE HOL	NSCT-3P874	(1)	25051087	
P5001	SOCKET	AC3FAH2-AU-B	1	25053400	
P5002	SOCKET	AC3FAH2-AU-B	1	25053400	
P5201	SOCKET	AC3MAH1-AU-B	1	25053530	
P5202	SOCKET	AC3MAH1-AU-B	1	25053530	
P5203	SOCKET	AC3MAH1-AU-B	1	25053530	
P5204	SOCKET	AC3MAH1-AU-B	1	25053530	
P5205	SOCKET	AC3MAH1-AU-B	1	25053530	
P5206	SOCKET	AC3MAH1-AU-B	1	25053530	
P5207	SOCKET	AC3MAH1-AU-B	1	25053530	
P5217	SOCKET	AC3MAH1-AU-B	1	25053530	
P5221A	PLUG	NPLG-13P141	1	25055157	
P6605A	PLUG	NPLG-5P119	1	25055135	
P6606A	WIRE HOL	CHD-1.5-3	1	25053535	
P6606Aor	WIRE HOL	NSCT-3P874	(1)	25051087	
P6606B	WIRE HOL	CHD-1.5-3	1	25053535	
P6606Bor	WIRE HOL	NSCT-3P874	(1)	25051087	
P9200	PLUG	NPLG-8P122	1	25055138	
P9201	WIRE HARNESS ASSEMBLY	NSAS-5P2109	1	2009991298UL	
P9201A	WIRE HOL	CHD-1.5-5	1	25053536	
P9201Aor	WIRE HOL	NSCT-5P876	(1)	25051089	
P9301	PLUG	NPLG-5P119	1	25055135	
P9303B	PLUG	NPLG-9P137	1	25055153	
Q5901A	HEAT SINK	(RAD-255)	1	27160647	
Q5901B	SCREW	3P+6FN(3BC)	2	82143006GR	
Q5903A	HEAT SINK	(RAD-255)	1	27160647	
Q5903B	SCREW	3P+6FN(3BC)	2	82143006GR	
RL5201	RELAY	NRL-2P2A-DC12-207	1	25065726	
RL5201 or	RELAY	NRL-2P2A-DC12-178	(1)	25065664	
RL5202	RELAY	NRL-2P2A-DC12-207	1	25065726	
RL5202 or	RELAY	NRL-2P2A-DC12-178	(1)	25065664	
RL5203	RELAY	NRL-2P2A-DC12-207	1	25065726	
RL5203 or	RELAY	NRL-2P2A-DC12-178	(1)	25065664	
RL5204	RELAY	NRL-2P2A-DC12-207	1	25065726	
RL5204 or	RELAY	NRL-2P2A-DC12-178	(1)	25065664	
RL5205	RELAY	NRL-2P2A-DC12-207	1	25065726	
RL5205 or	RELAY	NRL-2P2A-DC12-178	(1)	25065664	
RL5206	RELAY	NRL-2P2A-DC12-207	1	25065726	
RL5206 or	RELAY	NRL-2P2A-DC12-178	(1)	25065664	
RL5207	RELAY	NRL-2P2A-DC12-207	1	25065726	
RL5207 or	RELAY	NRL-2P2A-DC12-178	(1)	25065664	
RL5211	RELAY	NRL-2P2A-DC12-207	1	25065726	



RL5211 or	RELAY	NRL-2P2A-DC12-178	(1)	25065664	
RL5212	RELAY	NRL-2P2A-DC12-207	1	25065726	
RL5212 or	RELAY	NRL-2P2A-DC12-178	(1)	25065664	
RL5217	RELAY	NRL-2P2A-DC12-207	1	25065726	
RL5217 or	RELAY	NRL-2P2A-DC12-178	(1)	25065664	
RL5301	RELAY	NRL-2P2A-DC12-207	1	25065726	
RL5301 or	RELAY	NRL-2P2A-DC12-178	(1)	25065664	

U006

BAAF-1806-1A

: NSP

CIRCUIT NO	PART NAME	DESCRIPTION	Q'TY	PART NO. (SN)	REMARKS
<b>[SEMI CONDUCTOR]</b>					
D5208	CHIP TYPE DIODE	DA2J10100	1	223303R2	
D5208 or	CHIP TYPE DIODE	1SS352	(1)	223234R2	
D5209	CHIP TYPE DIODE	DA2J10100	1	223303R2	
D5209 or	CHIP TYPE DIODE	1SS352	(1)	223234R2	
D5216	CHIP TYPE DIODE	DA2J10100	1	223303R2	
D5216 or	CHIP TYPE DIODE	1SS352	(1)	223234R2	
D9001	DIODE	S1WB(A)60B-7062	1	22380377R2	
D9002	SPECIFIED DIODE	P6SMB200A-M3/52T	1	225505R2	
D9003	DIODE	US1K-E3/61T	1	22380376R2	
D9004	DIODE	RF301BM2STL	1	22380388R2	
D9006	DIODE	M1FL20U	1	223276R2	
D9008	DIODE	RB050M-30GTR	1	22380373R2	
D9011	CHIP TYPE DIODE	DA2J10100	1	223303R2	
D9011 or	CHIP TYPE DIODE	1SS352	(1)	223234R2	
D9012	ZENER DIODE	DZ2J360M0L	1	224763600R2	
D9012 or	ZENER DIODE	UDZS36B	(1)	224553600R2	
D9013	SPECIFIED DIODE	P6SMB20A-M3/52	1	225515R2	
D9018	ZENER DIODE	DZ2J200M0L	1	224762000R2	
D9018 or	ZENER DIODE	UDZS20B	(1)	224552000R2	
Q5208	TRANSISTOR	KRC105S	1	2217290R2	
Q5208 or	TRANSISTOR	RN1405	(1)	2214500R2	
Q5208 or	TRANSISTOR	DTC123JKA	(1)	2216690R2	
Q5226	TRANSISTOR	KRC105S	1	2217290R2	
Q5226 or	TRANSISTOR	RN1405	(1)	2214500R2	
Q5226 or	TRANSISTOR	DTC123JKA	(1)	2216690R2	
Q9001	HYBRID IC	STR-A6051M	1	222154	
Q9003	HYBRID IC	EL816MX	1	22242845	
Q9003 or	HYBRID IC	PC123X8YFZ0F	(1)	22242771	
Q9004	HYBRID IC	KIA431A-AT/P	1	22242770T	
Q9005	TRANSISTOR	KRC102S	1	2216190R2	
Q9005 or	TRANSISTOR	RN1402	(1)	2214470R2	
Q9006	TRANSISTOR	2SC2712-GR	1	2213145R2	
Q9032	TRANSISTOR	KRC102S	1	2216190R2	
Q9032 or	TRANSISTOR	RN1402	(1)	2214470R2	
Q9033	TRANSISTOR	KRA102S	1	2216220R2	
Q9033 or	TRANSISTOR	RN2402	(1)	2214530R2	
<b>[TRANS COIL]</b>					
L9001	CHOKE COIL	EM-UT2014-0033	1	231474	
L9002	CHOKE COIL	RCR1010NP-100M	1	231449M100	
L9004	CORE	BLM18PG181SN1D	1	2350005R1	
L9005	CORE	BLM18PG181SN1D	1	2350005R1	
T9001	POWER TRANSFORMER	NPT-1632S	1	2302076	!
T9001 or	POWER TRANSFORMER	NPT-1633S	(1)	2302077	!
<b>[CAPACITOR]</b>					
C5208	CHIP TYPE CERAMIC CAPACITOR	CC725CH1H-221J1	1	342102214R1	
C5209	CHIP TYPE CERAMIC CAPACITOR	CC725CH1H-221J1	1	342102214R1	
C5218	CHIP TYPE CERAMIC CAPACITOR	CC725CH1H-221J1	1	342102214R1	

C5219	CHIP TYPE CERAMIC CAPACITOR	CC725CH1H-221J1	1	342102214R1	
C5248	CHIP TYPE CERAMIC CAPACITOR	CK725B1H-104K1	1	332101045R1	
C5249	CHIP TYPE CERAMIC CAPACITOR	CK725B1H-104K1	1	332101045R1	
C5266	CHIP TYPE CERAMIC CAPACITOR	CC725CH1H-221J1	1	342102214R1	
C5276	CHIP TYPE CERAMIC CAPACITOR	CC725CH1H-221J1	1	342102214R1	
C5286	CHIP TYPE CERAMIC CAPACITOR	CK725B1H-104K1	1	332101045R1	
C9001	IS TYPE CAPACITOR	LE104-MX-C3.5	1	3800049S	!
C9002	ELECTROLYTIC CAPACITOR	CE04W200V-100M(KXJ)	1	3500233S	
C9003	PW TYPE ELECTROLYTIC CAPACITOR	CE04W50V-10M(PW)	1	393781007T	
C9004	PW TYPE ELECTROLYTIC CAPACITOR	CE04W25V-1000M(PW)	1	393751027S	
C9006	PW TYPE ELECTROLYTIC CAPACITOR	CE04W25V-470M(PW)	1	393754717T	
C9009	CHIP TYPE CERAMIC CAPACITOR	GRM31A7U3D220JW31D	1	3300071R1	
C9010	IS TYPE CAPACITOR	DE1E3KX102MB4BL01	1	3300066S	!
C9011	CHIP TYPE CERAMIC CAPACITOR	CK725B1C-104K1	1	332121045R1	
C9012	IS TYPE CAPACITOR	LE103-C3.5	1	3800042S	!
C9013	UTSP TYPE ELECTROLYTIC CAPACITOR	CE04W25V-220M(UTSP)	1	397552217T	
C9014	CHIP TYPE CERAMIC CAPACITOR	CK725B1H-103K1	1	332101035R1	
C9015	CHIP TYPE CERAMIC CAPACITOR	CK725B1H-104K1	1	332101045R1	
C9016	CHIP TYPE CERAMIC CAPACITOR	CK725B1H-332K1	1	332103325R1	
C9018	IS TYPE CAPACITOR	LE104-MX-C3.5	1	3800049S	!
C9019	IS TYPE CAPACITOR	DE1E3KX102MB4BL01	1	3300066S	!
C9020	IS TYPE CAPACITOR	DE1E3KX102MB4BL01	1	3300066S	!
C9023	CHIP TYPE CERAMIC CAPACITOR	CK725B1H-104K1	1	332101045R1	
C9024	CHIP TYPE CERAMIC CAPACITOR	CK725B1H-104K1	1	332101045R1	
<b>[RESISTOR]</b>					
R5188	CHIP TYPE CARBON RESISTOR	RN72K1J-103JE	1	435031034R1	
R5189	CHIP TYPE CARBON RESISTOR	RN72K1J-103JE	1	435031034R1	
R5198	CHIP TYPE CARBON RESISTOR	RN72K1J-103JE	1	435031034R1	
R5199	CHIP TYPE CARBON RESISTOR	RN72K1J-103JE	1	435031034R1	
R5208	CHIP TYPE CARBON RESISTOR	RN72K1J-470JE	1	435034704R1	
R5209	CHIP TYPE CARBON RESISTOR	RN72K1J-470JE	1	435034704R1	
R5218	CHIP TYPE CARBON RESISTOR	RN72K1J-470JE	1	435034704R1	
R5219	CHIP TYPE CARBON RESISTOR	RN72K1J-470JE	1	435034704R1	
R5226	CHIP TYPE CARBON RESISTOR	RN72K1J-103JE	1	435031034R1	
R5236	CHIP TYPE CARBON RESISTOR	RN72K1J-103JE	1	435031034R1	
R5246	CHIP TYPE CARBON RESISTOR	RN72K1J-470JE	1	435034704R1	
R5251	CHIP TYPE CARBON RESISTOR	RN72K1J-000JE	1	435030004R1	
R5256	CHIP TYPE CARBON RESISTOR	RN72K1J-470JE	1	435034704R1	
R7290	CHIP TYPE CARBON RESISTOR	RN72K1J-000JE	1	435030004R1	
R7291	CHIP TYPE CARBON RESISTOR	RN72K1J-000JE	1	435030004R1	
R9002	CHIP TYPE CARBON RESISTOR	RN72K1J-000JE	1	435030004R1	
R9006	CHIP TYPE CARBON RESISTOR	RN72K1J-392JE	1	435033924R1	
R9007	CHIP TYPE CARBON RESISTOR	RN72K1J-273FE	1	435032732R1	
R9008	CHIP TYPE CARBON RESISTOR	RN72K1J-822JE	1	435038224R1	
R9009	CHIP TYPE CARBON RESISTOR	RN72K1J-103JE	1	435031034R1	
R9010	METAL OXIDE FILM RESISTOR	RS1/2WBJ-68	1	443526804T	
R9011	NON-FLAMMABLE CARBON FILM RESISTOR	R25J-22	1	415472204T	
R9014	METAL RESISTOR	RNU1WCJ-1	1	453630104T	
R9017	CHIP TYPE CARBON RESISTOR	RN72K1J-332JE	1	435033324R1	
R9018	CHIP TYPE CARBON RESISTOR	RN72K1J-182JE	1	435031824R1	
R9022	CHIP TYPE CARBON RESISTOR	RN72K1J-152JE	1	435031524R1	
R9023	CHIP TYPE CARBON RESISTOR	KTR18EZPF6803	1	435236842R1	
R9024	CHIP TYPE CARBON RESISTOR	KTR18EZPF6803	1	435236842R1	
R9025	CHIP TYPE CARBON RESISTOR	KTR18EZPF6803	1	435236842R1	
R9038	METAL OXIDE FILM RESISTOR	RS1/2WBJ-100	1	443521014T	
R9051	CHIP TYPE CARBON RESISTOR	RN72K1J-472JE	1	435034724R1	
R9052	CHIP TYPE CARBON RESISTOR	RN72K1J-104JE	1	435031044R1	
R9055	METAL OXIDE FILM RESISTOR	RS1/2WBJ-100	1	443521014T	
R9057	CHIP TYPE CARBON RESISTOR	RN72K1J-332JE	1	435033324R1	
R9058	CHIP TYPE CARBON RESISTOR	RN72K1J-332JE	1	435033324R1	
<b>[SW TRM]</b>					
F9001	FUSE	T1A-SEUL-T250V	1	252397T	!

P9001A	FUSE LABEL	T1A 250V	1	29392374	!
P2101B	PLUG	NPLG-11P0966	1	25056016	
P2791	RETAINER	(PTH)	1	27141884-1	
P2792	TRM-423(SCREW)	NEJITANSI ST3	1	25060495	
P2793	TRM-423(SCREW)	NEJITANSI ST3	1	25060495	
P4511B	SOCKET	IMSA-9142S-26A	1	25053235	
P4591B	PLUG	IMSA-9142B-26A	1	25056603	
P5208	SOCKET	AC3MAH1-AU-B	1	25053530	
P5209	SOCKET	AC3MAH1-AU-B	1	25053530	
P5216	SOCKET	AC3MAH1-AU-B	1	25053530	
P5221B	WIRE HARNESS ASSEMBLY	NSAS-26P2314	1	200C4292615UL	
P9001	WIRE HARNESS ASSEMBLY	NSAS-5P2113	1	2009991302UL	
P9001A	WIRE HOL	CHD-1.5-5	1	25053536	
P9001Aor	WIRE HOL	NSCT-5P876	(1)	25051089	
P9002	PLUG	NPLG-2P631	1	25055675	
P9004	TRM(SCREW)	NEJITANSI M3	1	25065425	
P9005	PLUG	NPLG-2P631	1	25055675	
P9006	TRM(SCREW)	NEJITANSI M3	1	25065425	
P9011A	PLUG	NPLG-2P631	1	25055675	
RL5208	RELAY	NRL-2P2A-DC12-207	1	25065726	
RL5208 or	RELAY	NRL-2P2A-DC12-178	(1)	25065664	
RL5209	RELAY	NRL-2P2A-DC12-207	1	25065726	
RL5209 or	RELAY	NRL-2P2A-DC12-178	(1)	25065664	
RL5216	RELAY	NRL-2P2A-DC12-207	1	25065726	
RL5216 or	RELAY	NRL-2P2A-DC12-178	(1)	25065664	
RL9001	RELAY	NRL-1P10A-DC9-188	1	25065693	!

**U008**

BAHDM-1822-1A

: NSP

CIRCUIT NO	PART NAME	DESCRIPTION	Q'TY	PART NO. (SN)	REMARKS
<b>[SEMI CONDUCTOR]</b>					
D200	CHIP TYPE DIODE	CRS09(TE85L_Q)	1	223274R2	
D222	ESD D	AOZ8804ADI	1	225502R2	
D223	ESD D	AOZ8804ADI	1	225502R2	
D224	ESD D	AOZ8804ADI	1	225502R2	
D225	ESD	IMSA-6802-01Y901_1608SIZE	1	4000255AR1	
D226	ESD D	AOZ8804ADI	1	225502R2	
D227	ESD D	AOZ8804ADI	1	225502R2	
Q200	HYBRID IC	VS100TX	1	22242850R3	
Q201	HYBRID IC	S-13A1A18-U5T1U3	1	22242943R2	
Q205	HYBRID IC	W25Q80DVSNI	1	222W0142R2	firmware
Q212	HYBRID IC	FR9888CSPCTR	1	22242839R2	
Q218	HYBRID IC	74LCX125FT	1	22274125BR2TO	
Q8500	HYBRID IC	PCA9515BDGKR	1	22242895R2	
<b>[TRANS COIL]</b>					
L200	CHOKE COIL	LBC2518T100M	1	231364M100R2	
L201	CORE	BLM18PG181SN1D	1	2350005R1	
L202	CHOKE COIL	1264EY-3R3N	1	231461N033R2	
L203	CHOKE COIL	C6-K5RA-10UH	1	231451P100R2	
L209	CORE	BLM18PG181SN1D	1	2350005R1	
L210	CORE	BLM18PG181SN1D	1	2350005R1	
L211	CORE	BLM18KG260TN1	1	2350020R1	
L212	CORE	BLM18KG260TN1	1	2350020R1	
L214	CORE	BLM18PG181SN1D	1	2350005R1	
L230	IF TRANSFORMER	H7019FNLT	1	231476R2	
L231	CORE	BLM18KG260TN1	1	2350020R1	
L232	CORE	BLM18PG181SN1D	1	2350005R1	
L233	CORE	BLM18KG260TN1	1	2350020R1	
L234	CORE	BLM18KG260TN1	1	2350020R1	

L8500	CORE	BLM15PX181SN1D	1	2350033R1
X203	CRYSTAL	DSO321SR-AA-125MHz	1	3010530R2
<b>[CAPACITOR]</b>				
C200	CHIP TANTAL	F93-6.3V-100M	1	395521017R2
C201	CHIP TYPE CERAMIC CAPACITOR	CK725B1C-104K0	1	332011045R1
C202	CHIP TYPE CERAMIC CAPACITOR	CK725B1C-104K0	1	332011045R1
C203	CHIP TYPE CERAMIC CAPACITOR	CK725B1C-104K0	1	332011045R1
C204	CHIP TYPE CERAMIC CAPACITOR	CK725B1C-104K0	1	332011045R1
C205	CHIP TYPE CERAMIC CAPACITOR	CK732B16V-106K	1	332071065R2
C208	CHIP TYPE CERAMIC CAPACITOR	CK725B1C-104K0	1	332011045R1
C209	CHIP TYPE CERAMIC CAPACITOR	CK725B1C-104K0	1	332011045R1
C210	CHIP TYPE CERAMIC CAPACITOR	CK725B1C-104K0	1	332011045R1
C211	CHIP TYPE CERAMIC CAPACITOR	CK725B1C-104K0	1	332011045R1
C214	CHIP TYPE CERAMIC CAPACITOR	CK725B1C-104K0	1	332011045R1
C216	CHIP TANTAL	F93-10V-100M	1	395531017R2
C217	CERAMIC CAPACITOR	GRM21BR72E103KW03L	1	3300073R2
C218	CERAMIC CAPACITOR	GR442QR73D102KW01L	1	3300072R2
C219	CHIP TYPE CERAMIC CAPACITOR	CK725B1H-103K0	1	332031035R1
C220	CHIP TYPE CERAMIC CAPACITOR	CK725B1H-103K0	1	332031035R1
C221	CERAMIC CAPACITOR	GRM21BR72E103KW03L	1	3300073R2
C222	CERAMIC CAPACITOR	GRM21BR72E103KW03L	1	3300073R2
C223	CERAMIC CAPACITOR	GRM21BR72E103KW03L	1	3300073R2
C224	CHIP TYPE CERAMIC CAPACITOR	CK725B1C-104K0	1	332011045R1
C226	CERAMIC CAPACITOR	GR442QR73D102KW01L	1	3300072R2
C228	CHIP TYPE CERAMIC CAPACITOR	CK725B0J-226M	1	332092267R2
C236	CHIP TYPE CERAMIC CAPACITOR	CK732B16V-106K	1	332071065R2
C237	CHIP TYPE CERAMIC CAPACITOR	CK732B16V-106K	1	332071065R2
C238	CHIP TYPE CERAMIC CAPACITOR	CK725B1C-104K0	1	332011045R1
C239	CHIP TYPE CERAMIC CAPACITOR	CK725B0J-226M	1	332092267R2
C240	CHIP TYPE CERAMIC CAPACITOR	CK725B0J-226M	1	332092267R2
C241	CHIP TYPE CERAMIC CAPACITOR	CK725B0J-226M	1	332092267R2
C243	CHIP TYPE CERAMIC CAPACITOR	CK725B1C-104K0	1	332011045R1
C246	CHIP TYPE CERAMIC CAPACITOR	CK725B1H-103K0	1	332031035R1
C247	CHIP TYPE CERAMIC CAPACITOR	CK725B1H-103K0	1	332031035R1
C251	CHIP TYPE CERAMIC CAPACITOR	CK725B1C-104K0	1	332011045R1
C253	CHIP TYPE CERAMIC CAPACITOR	CK725B0J-226M	1	332092267R2
C254	CHIP TYPE CERAMIC CAPACITOR	CK725B0J-226M	1	332092267R2
C256	CHIP TYPE CERAMIC CAPACITOR	CK725B1C-104K0	1	332011045R1
C265	CHIP TYPE CERAMIC CAPACITOR	CK725B0J-226M	1	332092267R2
C269	CHIP TANTAL	F93-6.3V-100M	1	395521017R2
C270	CHIP TANTAL	F93-10V-100M	1	395531017R2
C271	CHIP TANTAL	F93-6.3V-100M	1	395521017R2
C272	CHIP TANTAL	F93-6.3V-100M	1	395521017R2
C273	CHIP TANTAL	F93-10V-100M	1	395531017R2
C276	CHIP TYPE CERAMIC CAPACITOR	CK725B1C-104K0	1	332011045R1
C277	CHIP TYPE CERAMIC CAPACITOR	CK725B1C-104K0	1	332011045R1
C278	CHIP TYPE CERAMIC CAPACITOR	CK725B1C-104K0	1	332011045R1
C279	CHIP TYPE CERAMIC CAPACITOR	CK725B1C-104K0	1	332011045R1
C280	CHIP TYPE CERAMIC CAPACITOR	CK725B1C-104K0	1	332011045R1
C281	CHIP TYPE CERAMIC CAPACITOR	CK725B1C-104K0	1	332011045R1
C282	CHIP TYPE CERAMIC CAPACITOR	CK725B1C-104K0	1	332011045R1
C283	CHIP TYPE CERAMIC CAPACITOR	CK725B1C-104K0	1	332011045R1
C284	CHIP TYPE CERAMIC CAPACITOR	CK725B1C-104K0	1	332011045R1
C285	CHIP TYPE CERAMIC CAPACITOR	CK725B1C-104K0	1	332011045R1
C286	CHIP TYPE CERAMIC CAPACITOR	CK725B1C-104K0	1	332011045R1
C289	CHIP TYPE CERAMIC CAPACITOR	CK725B1C-104K0	1	332011045R1
C290	CHIP TYPE CERAMIC CAPACITOR	CK725B1C-104K0	1	332011045R1
C291	CHIP TYPE CERAMIC CAPACITOR	CK725B1C-104K0	1	332011045R1
C292	CHIP TYPE CERAMIC CAPACITOR	CK725B1C-104K0	1	332011045R1
C293	CHIP TYPE CERAMIC CAPACITOR	CK725B1C-104K0	1	332011045R1
C295	CHIP TYPE CERAMIC CAPACITOR	CK725B1C-104K0	1	332011045R1
C296	CHIP TYPE CERAMIC CAPACITOR	CK725B1C-104K0	1	332011045R1

C297	CHIP TYPE CERAMIC CAPACITOR	CK725B1C-104K0	1	332011045R1
C298	CHIP TYPE CERAMIC CAPACITOR	CK725B1C-104K0	1	332011045R1
C299	CHIP TYPE CERAMIC CAPACITOR	CK725B1C-104K0	1	332011045R1
C300	CHIP TYPE CERAMIC CAPACITOR	CK725B1C-104K0	1	332011045R1
C301	CHIP TYPE CERAMIC CAPACITOR	CK725B1C-104K0	1	332011045R1
C302	CHIP TYPE CERAMIC CAPACITOR	CK725B1C-104K0	1	332011045R1
C303	CHIP TYPE CERAMIC CAPACITOR	CK725B1C-104K0	1	332011045R1
C304	CHIP TYPE CERAMIC CAPACITOR	CK725B1C-104K0	1	332011045R1
C306	CHIP TYPE CERAMIC CAPACITOR	CK725B1C-104K0	1	332011045R1
C307	CHIP TYPE CERAMIC CAPACITOR	CK725B1C-104K0	1	332011045R1
C308	CHIP TYPE CERAMIC CAPACITOR	CK725B1C-104K0	1	332011045R1
C309	CHIP TYPE CERAMIC CAPACITOR	CK725B1C-104K0	1	332011045R1
C312	CHIP TYPE CERAMIC CAPACITOR	CK732B16V-106K	1	332071065R2
C349	CHIP TYPE CERAMIC CAPACITOR	CK725B1C-104K0	1	332011045R1
C8501	CHIP TYPE CERAMIC CAPACITOR	CK725B1H-102K0	1	332031025R1
C8502	CHIP TYPE CERAMIC CAPACITOR	CK725B1H-102K0	1	332031025R1
C8503	CHIP TYPE CERAMIC CAPACITOR	CK725B1C-104K0	1	332011045R1
C8504	CHIP TYPE CERAMIC CAPACITOR	CK732B16V-106K	1	332071065R2
<b>[RESISTOR]</b>				
R200	CHIP TYPE CARBON RESISTOR	RN72K1J-273JE	1	435032734R1
R201	CHIP TYPE CARBON RESISTOR	RN72K1J-123JE	1	435031234R1
R202	CHIP TYPE CARBON RESISTOR	RN72K1J-102JE	1	435031024R1
R203	CHIP TYPE CARBON RESISTOR	RN72K1J-472FE	1	435034722R1
R204	CHIP TYPE CARBON RESISTOR	RN72K1J-124FE	1	435031242R1
R205	CHIP TYPE CARBON RESISTOR	RN72K1J-223JE	1	435032234R1
R206	CHIP TYPE CARBON RESISTOR	RN72K1J-104JE	1	435031044R1
R209	CHIP TYPE CARBON RESISTOR	MCR03EZPF49R9(49.9_1%)	1	4100037R2
R210	CHIP TYPE CARBON RESISTOR	RN72K1J-473JE	1	435034734R1
R211	CHIP TYPE CARBON RESISTOR	MCR03EZPF49R9(49.9_1%)	1	4100037R2
R213	CHIP TYPE CARBON RESISTOR	MCR03EZPF49R9(49.9_1%)	1	4100037R2
R214	CHIP TYPE CARBON RESISTOR	MCR03EZPF49R9(49.9_1%)	1	4100037R2
R215	CHIP TYPE CARBON RESISTOR	MCR03EZPF49R9(49.9_1%)	1	4100037R2
R216	CHIP TYPE CARBON RESISTOR	MCR03EZPF49R9(49.9_1%)	1	4100037R2
R217	CHIP TYPE CARBON RESISTOR	MCR03EZPF49R9(49.9_1%)	1	4100037R2
R218	CHIP TYPE CARBON RESISTOR	RN72K1J-123FE	1	435031232R1
R219	CHIP TYPE CARBON RESISTOR	MCR03EZPF49R9(49.9_1%)	1	4100037R2
R221	CHIP TYPE CARBON RESISTOR	RN72K1J-471JE	1	435034714R1
R222	CHIP TYPE CARBON RESISTOR	RN72K1J-221JE	1	435032214R1
R223	CHIP TYPE CARBON RESISTOR	RN72K1J-750JE	1	435037504R1
R224	CHIP TYPE CARBON RESISTOR	RN72K1J-750JE	1	435037504R1
R225	CHIP TYPE CARBON RESISTOR	RN72K1J-182JE	1	435031824R1
R226	CHIP TYPE CARBON RESISTOR	RN72K1J-102JE	1	435031024R1
R227	CHIP TYPE CARBON RESISTOR	RN72K1J-750JE	1	435037504R1
R230	CHIP TYPE CARBON RESISTOR	RN72K1J-182JE	1	435031824R1
R231	CHIP TYPE CARBON RESISTOR	RN72K1J-102JE	1	435031024R1
R232	CHIP TYPE CARBON RESISTOR	RN72K1J-392FE	1	435033922R1
R233	CHIP TYPE CARBON RESISTOR	RN72K1J-121FE	1	435031212R1
R234	CHIP TYPE CARBON RESISTOR	RN72K1J-750JE	1	435037504R1
R235	CHIP TYPE CARBON RESISTOR	RN72K1J-000JE	1	435030004R1
R236	CHIP TYPE CARBON RESISTOR	RN72K1J-000JE	1	435030004R1
R237	CHIP TYPE CARBON RESISTOR	RN72K1J-101JE	1	435031014R1
R238	CHIP TYPE CARBON RESISTOR	RN72K1J-104JE	1	435031044R1
R242	CHIP TYPE CARBON RESISTOR	RN72K1J-473JE	1	435034734R1
R243	CHIP TYPE CARBON RESISTOR	RN72K1J-102JE	1	435031024R1
R244	CHIP TYPE CARBON RESISTOR	RN72K1J-102JE	1	435031024R1
R245	CHIP TYPE CARBON RESISTOR	RN72K1J-102JE	1	435031024R1
R246	CHIP TYPE CARBON RESISTOR	RN72K1J-473JE	1	435034734R1
R249	CHIP TYPE CARBON RESISTOR	RN72K1J-102JE	1	435031024R1
R253	CHIP TYPE CARBON RESISTOR	RN72K1J-102JE	1	435031024R1
R255	CHIP TYPE CARBON RESISTOR	RN72K1J-102JE	1	435031024R1
R258	CHIP TYPE CARBON RESISTOR	RN72K1J-102JE	1	435031024R1
R261	CHIP TYPE CARBON RESISTOR	RN72K1J-102JE	1	435031024R1

R266	CHIP TYPE CARBON RESISTOR	RN72K1J-102JE	1	435031024R1
R267	CHIP TYPE CARBON RESISTOR	RN72K1J-000JE	1	435030004R1
R272	CHIP TYPE CARBON RESISTOR	RN72K1J-102JE	1	435031024R1
R275	CHIP TYPE CARBON RESISTOR	RN72K1J-000JE	1	435030004R1
R277	CHIP TYPE CARBON RESISTOR	RN72K1J-102JE	1	435031024R1
R281	CHIP TYPE CARBON RESISTOR	RN72K1J-332JE	1	435033324R1
R282	CHIP TYPE CARBON RESISTOR	RN72K1J-103FE	1	435031032R1
R284	CHIP TYPE CARBON RESISTOR	RN72K1J-102FE	1	435031022R1
R286	CHIP TYPE CARBON RESISTOR	RN72K1J-103JE	1	435031034R1
R292	CHIP TYPE CARBON RESISTOR	RN72K1J-472JE	1	435034724R1
R293	CHIP TYPE CARBON RESISTOR	RN72K1J-101JE	1	435031014R1
R294	CHIP TYPE CARBON RESISTOR	RN72K1J-101JE	1	435031014R1
R295	CHIP TYPE CARBON RESISTOR	RN72K1J-101JE	1	435031014R1
R296	CHIP TYPE CARBON RESISTOR	RN72K1J-101JE	1	435031014R1
R297	CHIP TYPE CARBON RESISTOR	RN72K1J-101JE	1	435031014R1
R298	CHIP TYPE CARBON RESISTOR	RN72K1J-101JE	1	435031014R1
R299	CHIP TYPE CARBON RESISTOR	RN72K1J-101JE	1	435031014R1
R300	CHIP TYPE CARBON RESISTOR	RN72K1J-101JE	1	435031014R1
R372	CHIP TYPE CARBON RESISTOR	RN72K1J-220JE	1	435032204R1
R373	CHIP TYPE CARBON RESISTOR	RN72K1J-220JE	1	435032204R1
R378	CHIP TYPE CARBON RESISTOR	RN72K1J-000JE	1	435030004R1
R381	CHIP TYPE CARBON RESISTOR	RN72K1J-220JE	1	435032204R1
R382	CHIP TYPE CARBON RESISTOR	RN72K1J-220JE	1	435032204R1
R385	CHIP TYPE CARBON RESISTOR	RN72K1J-102JE	1	435031024R1
R391	CHIP TYPE CARBON RESISTOR	RN72K1J-102JE	1	435031024R1
R392	CHIP TYPE CARBON RESISTOR	RN72K1J-102JE	1	435031024R1
R393	CHIP TYPE CARBON RESISTOR	RN72K1J-102JE	1	435031024R1
R394	CHIP TYPE CARBON RESISTOR	RN72K1J-102JE	1	435031024R1
R395	CHIP TYPE CARBON RESISTOR	RN72K1J-104JE	1	435031044R1
R8503	CHIP TYPE CARBON RESISTOR	RN72K1J-473JE	1	435034734R1
R8504	CHIP TYPE CARBON RESISTOR	RN72K1J-473JE	1	435034734R1
R8505	CHIP TYPE CARBON RESISTOR	RN72K1J-472JE	1	435034724R1
R8506	CHIP TYPE CARBON RESISTOR	RN72K1J-472JE	1	435034724R1
R8507	CHIP TYPE CARBON RESISTOR	RN72K1J-473JE	1	435034734R1
<b>[SW TRM]</b>				
P200	SOCKET	51U019S-3HFDN-BD-SM	1	25053549R3
P200 or	SOCKET	HDMI(47266-4101)	( 1)	25053389R3
P200 or	SOCKET	TCX3423-311387	( 1)	25060513R3
P202	TRM-423(SCREW)	NEJITANSI ST3	1	25060495
P212A	SOCKET	IMSA-9618S-17A	1	25053342R2
P213	SOCKET	NSCT-8P2471	1	25052574R2
P215	SOCKET	RC1-1000000D	1	25053518
P8500	SOCKET	TCX3255-611187	1	25053413R3
P8501	SOCKET	TCX3423-311387	1	25060513R3
P8501 or	SOCKET	HDMI(47266-4101)	( 1)	25053389R3
P8502	TERMINAL	NTM-1P233(M1969)	1	25060302