

Service Manual

SERIAL NO.3650
052000

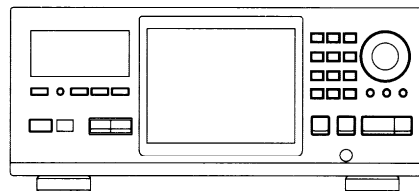

DVD CHANGER PLAYER

DPT-1

Black model

BUDD1N	120V AC	Region:1
--------	---------	----------

CONTENTS

1. SAFETY INFORMATION	2	7.1.7 ABOUT SERVICE IN THE MECHANISM FAILURE	79
2. EXPLODED VIEWS AND PARTS LIST	3	7.2 PARTS	80
3. BLOCK DIAGRAM AND SCHEMATIC DIAGRAM ..	12	7.2.1 IC	80
4. PCB CONNECTION DIAGRAM	39	7.2.2 DISPLAY	95
5. PCB PARTS LIST	55	8. PANEL FACILITIES AND SPECIFICATIONS	96
6. ADJUSTMENT	62		
7. GENERAL INFORMATION	66		
7.1 DIAGNOSIS	66		
7.1.1 TEST MODE SCREEN DISPLAY	66		
7.1.2 TROUBLE SHOOTING	68		
7.1.3 OPERATION FLOW CHART	69		
7.1.4 ERROR CODE	70		
7.1.5 INTERFACE CONNECTOR	74		
7.1.6 DISASSEMBLY	77		

Resetting the Changer to System Settings

To reset the changer, press and hold ■ (stop) on the front panel when pressing ⏻ STANDBY/ ON on the front panel to turn the unit from standby to on.

All input text data, program memory, saved settings from functions such as Function Memory and Condition Memory are cleared, and all Setup screen menus are returned to factory settings.

Integra Division of
ONKYO U.S.A. CORPORATION
200 Williams Drive, Ramsey, N.J. 07446, U.S.A.
Tel: 201-825-7950 Fax: 201-825-8150 E-mail: integra@onkyousa.com

Integra Division of
ONKYO CORPORATION
Sales & Product Planning Div.:2-1, Nisshin-cho, Neyagawa-shi,
OSAKA 572-8540, JAPAN
Tel: 072-831-8111 Fax: 072-833-5222

<http://www.onkyo.co.jp/>

1. SAFETY INFORMATION

This service manual is intended for qualified service technicians ; it is not meant for the casual do-it-yourselfer. Qualified technicians have the necessary test equipment and tools, and have been trained to properly and safely repair complex products such as those covered by this manual.

Improperly performed repairs can adversely affect the safety and reliability of the product and may void the warranty. If you are not qualified to perform the repair of this product properly and safely, you should not risk trying to do so and refer the repair to a qualified service technician.



WARNING

This product contains lead in solder and certain electrical parts contain chemicals which are known to the state of California to cause cancer, birth defects or other reproductive harm.

Health & Safety Code Section 25249.6 – Proposition 65



NOTICE

(FOR CANADIAN MODEL ONLY)

Fuse symbols  (fast operating fuse) and/or  (slow operating fuse) on PCB indicate that replacement parts must be of identical designation.

REMARQUE

(POUR MODÈLE CANADIEN SEULEMENT)

Les symboles de fusible  (fusible de type rapide) et/ou  (fusible de type lent) sur CCI indiquent que les pièces de remplacement doivent avoir la même désignation.

(FOR USA MODEL ONLY)

1. SAFETY PRECAUTIONS

The following check should be performed for the continued protection of the customer and service technician.

LEAKAGE CURRENT CHECK

Measure leakage current to a known earth ground (water pipe, conduit, etc.) by connecting a leakage current tester such as Simpson Model 229-2 or equivalent between the earth ground and all exposed metal parts of the appliance (input/output terminals, screwheads, metal overlays, control shaft, etc.). Plug the AC line cord of the appliance directly into a 120V AC 60Hz outlet and turn the AC power switch on. Any current measured must not exceed 0.5mA.

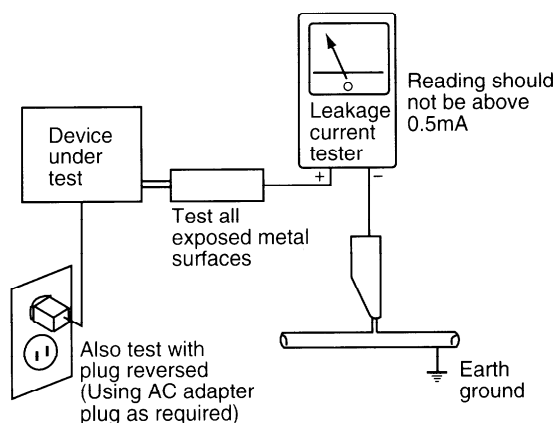

AC Leakage Test

ANY MEASUREMENTS NOT WITHIN THE LIMITS OUTLINED ABOVE ARE INDICATIVE OF A POTENTIAL SHOCK HAZARD AND MUST BE CORRECTED BEFORE RETURNING THE APPLIANCE TO THE CUSTOMER.

2. PRODUCT SAFETY NOTICE

Many electrical and mechanical parts in the appliance have special safety related characteristics. These are often not evident from visual inspection nor the protection afforded by them necessarily can be obtained by using replacement components rated for voltage, wattage, etc. Replacement parts which have these special safety characteristics are identified in this Service Manual.

Electrical components having such features are identified by marking with a Δ on the schematics and on the parts list in this Service Manual.

The use of a substitute replacement component which does not have the same safety characteristics as the ONKYO recommended replacement one, shown in the parts list in this Service Manual, may create shock, fire, or other hazards.

Product Safety is continuously under review and new instructions are issued from time to time. For the latest information, always consult the current ONKYO Service Manual. A subscription to, or additional copies of, ONKYO Service Manual may be obtained at a nominal charge from ONKYO.

2. EXPLODED VIEWS AND PARTS LIST

- NOTES:**
- Parts marked by "NSP" are generally unavailable because they are not in our Master Spare Parts List.
 - The Δ mark found on some component parts indicates the importance of the safety factor of the part. Therefore, when replacing, be sure to use parts of identical designation.
 - Screws adjacent to \blacktriangledown mark on the product are used for disassembly.

2.1 PACKING

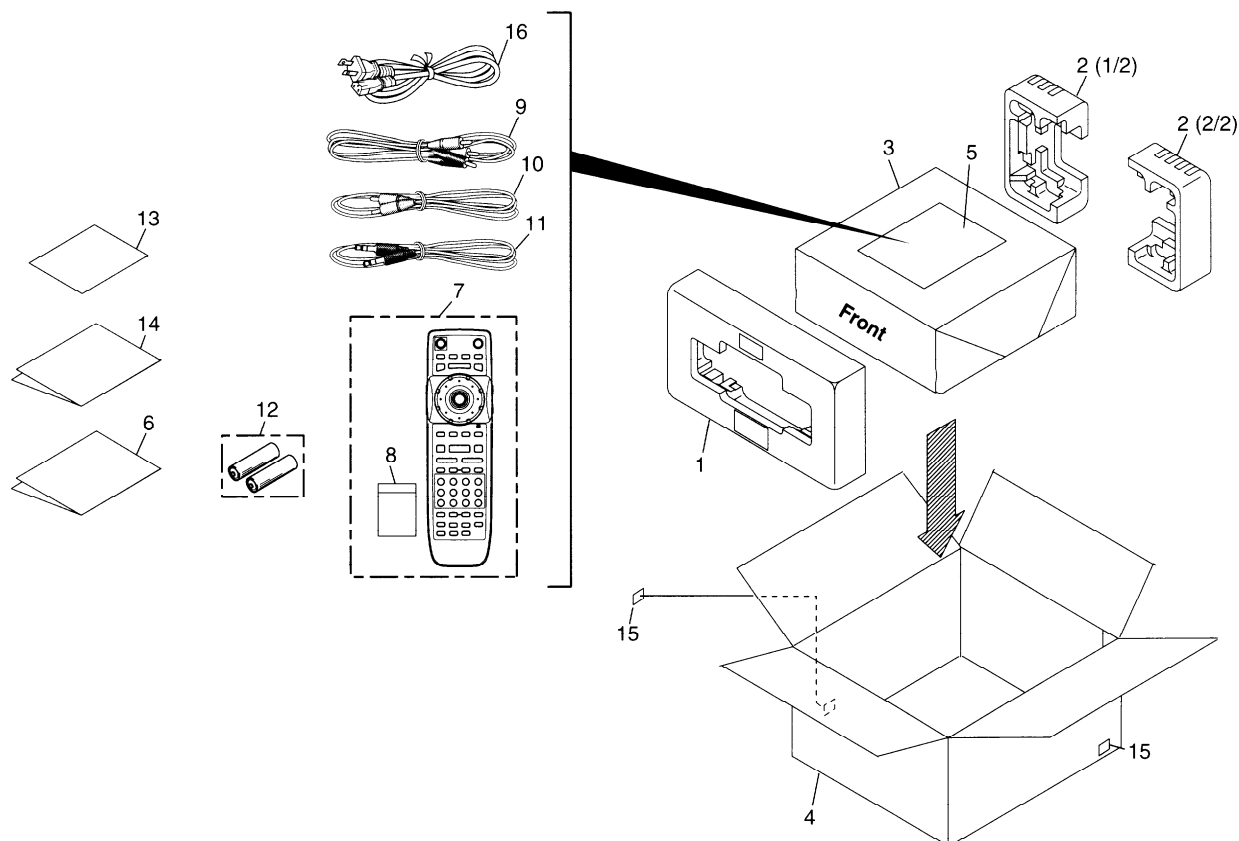

(1) PACKING PARTS LIST

Mark No.	Description	Part No.	Mark No.	Description	Part No.
1	Protector F	VHA1252	10	Video Cord (L = 1.5m)	VDE1034
2	Protector R	VHA1253	11	Master-Slave Control Cord (L = 0.75m)	RDE1023
3	Packing Sheet	RHC1023	12	Dry Cell Battery (R6P, AA)	3010054
4	Packing Case	VHG1913	13	SHEET	29095865
5	Polyethylene Bag B5	29100097-1A	14	Warranty Card	29365080B
6	Operating Instructions (English)	VRB1249	15	LABEL (UPC) AS	29362602
7	Remote Control Unit	VXX2708	16	AC CORD	253297KAW
8	Battery Cover	VNK4423			
9	Audio Cord (L = 1.5m)	VDE1033			

2.2 EXTERIOR SECTION (1/2)

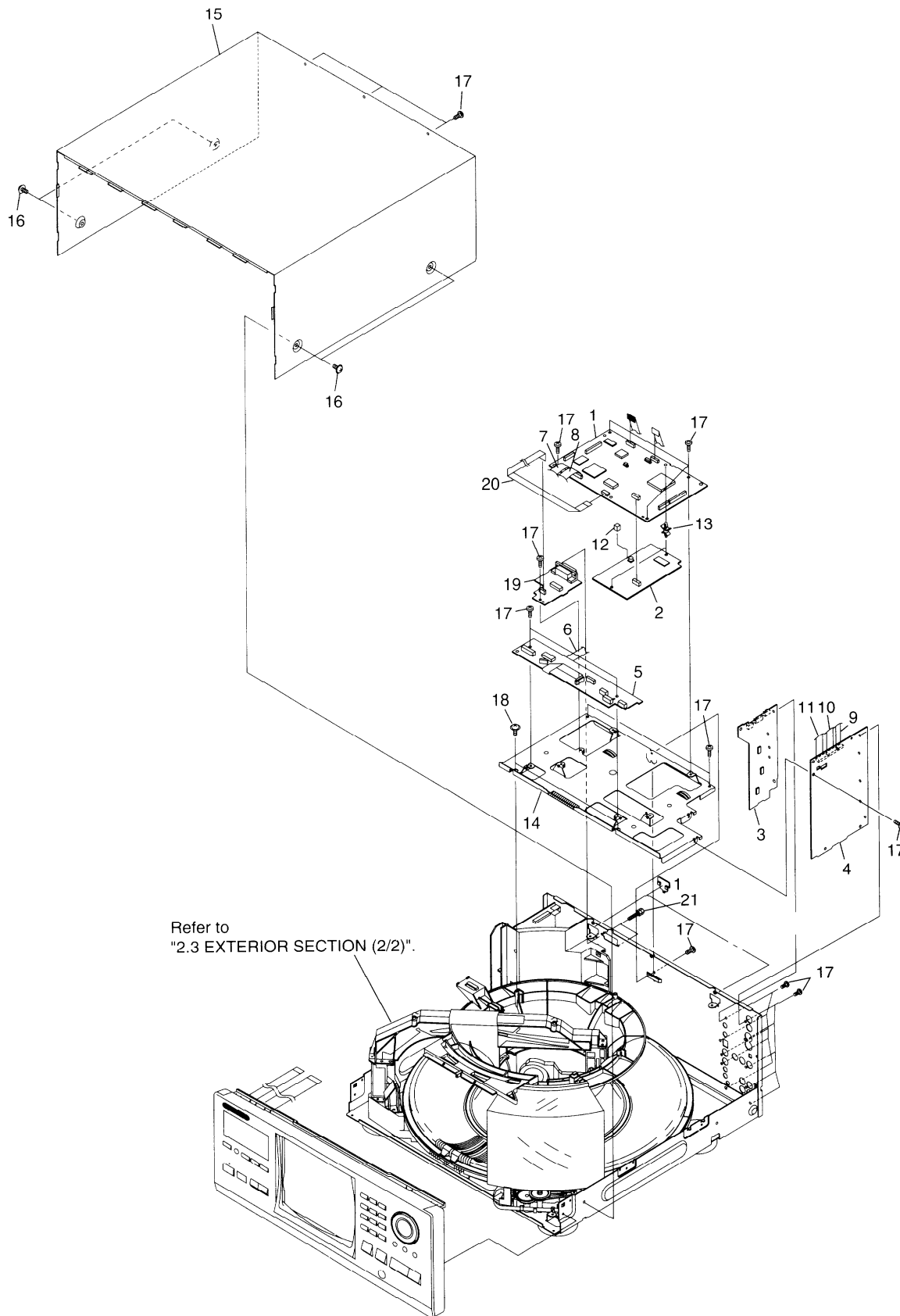

(1) EXTERIOR SECTION (1/2) PARTS LIST

Mark	No.	Description	Part No.	Mark	No.	Description	Part No.
	1	DVDM Assy	VWS1396		11	Flexible Cable (15P)	VDA1784
	2	VQEB Assy	VWV1669		12	PCB Support Cushion	VEC2079
	3	MSJB Assy	VWG2178		13	PCB Spacer	VEC2077
	4	AVJB Assy	VWV1720	NSP	14	Main Holder	VNE2215
	5	MDRB Assy	VWG2127		15	Bonnet Case S	VXX2692
	6	Flexible Cable (12P)	VDA1779		16	Screw	FBT40P080FZK
	7	Flexible Cable (11P)	VDA1781		17	Screw	BBZ30P080FZK
	8	Flexible Cable (12P)	VDA1778		18	Screw	IPZ30P080FMC
	9	Flexible Cable (7P)	VDA1782		19	232B Assy	VWG2129
	10	Flexible Cable (14P)	VDA1707		20	Flexible Cable (7P)	VDA1777
					21	Screw	DBA1078

2.3 EXTERIOR SECTION (2/2)

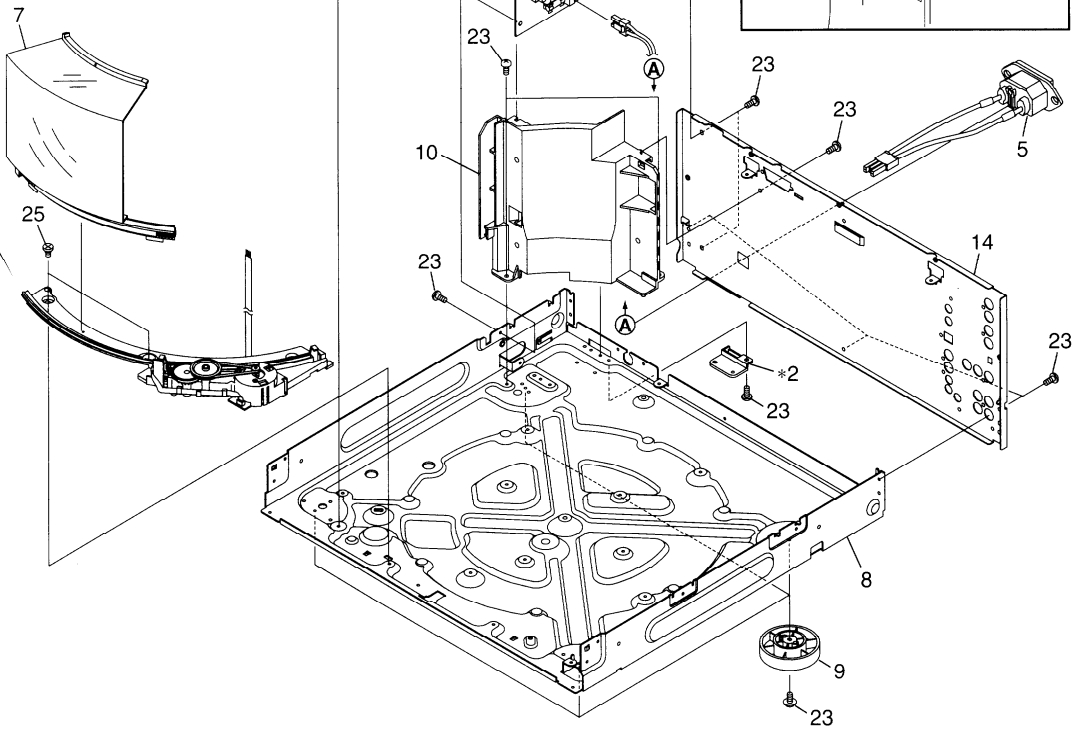
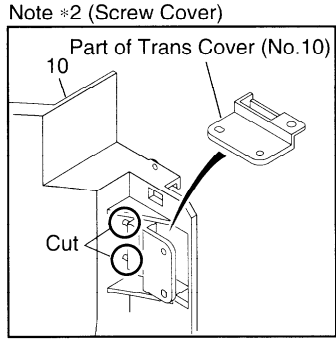
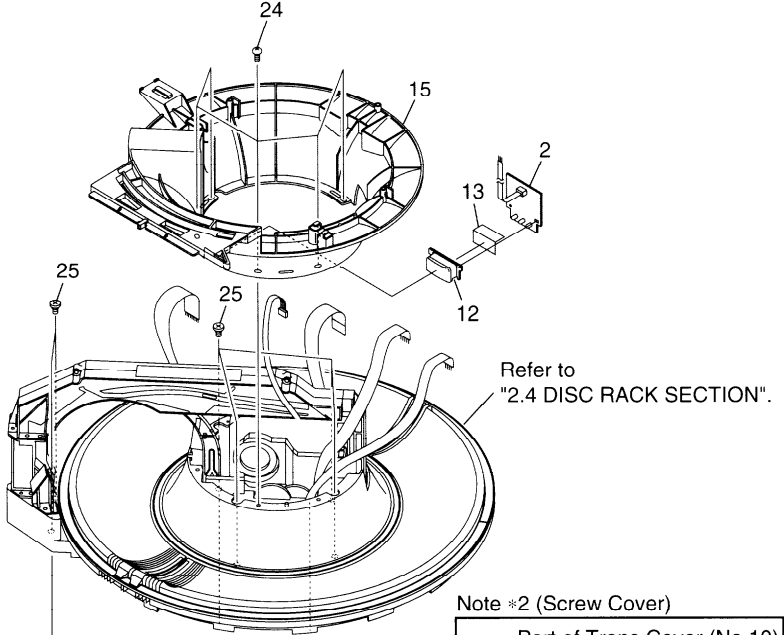
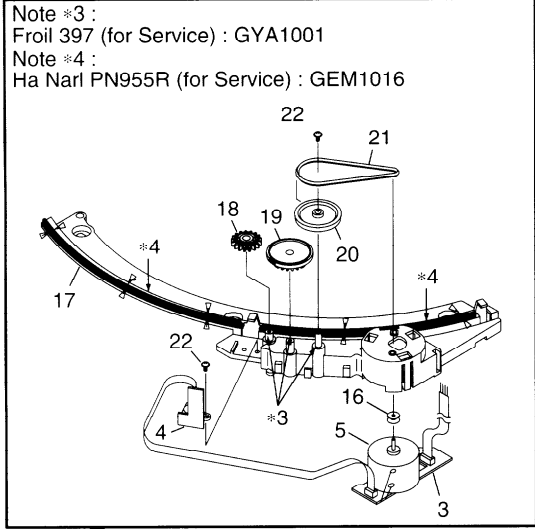

(1) EXTERIOR SECTION (2/2) PARTS LIST

Mark	No.	Description	Part No.	Mark	No.	Description	Part No.
△	1	POWER SUPPLY Assy	VWR1317	16	Motor Pulley	PNW1634	
NSP	2	LEDB Assy	VWG2124	17	Hood Base 301	PNW2791	
NSP	3	DOMB Assy	VWG2121	18	Gear M1	PNW2800	
NSP	4	DOSB Assy	VWG2122	19	Gear AW	PNW2906	
△	5	AC INLET Assy	V KP2251	20	Gear Pulley	VNL1662	
	6	Carriage Motor (DOOR)	VXM1033	21	Belt	PEB1300	
	7	Hood	VNK4629	22	Screw	IPZ20P080FMC	
NSP	8	Under Base DVD	VNA2125	23	Screw	BBZ30P080FZK	
	9	Insulator	AMR7198	24	Screw	IPZ30P080FMC	
	10	Trans Cover	VNK4542	25	Screw C	PBA1106	
	11	Flexible Cable (26P)	VDA1776				
	12	CR Lens	PNW2816				
	13	Dispersion Sheet	VEC2113				
	14	Rear Base	VNA2177				
	15	Center Pole 301	PNW2792				

2.4 DISC RACK SECTION

Note *3 :
 Froil 397 (for Service) : GYA1001
 Note *4 :
 Ha Narl PN955R (for Service) : GEM1016

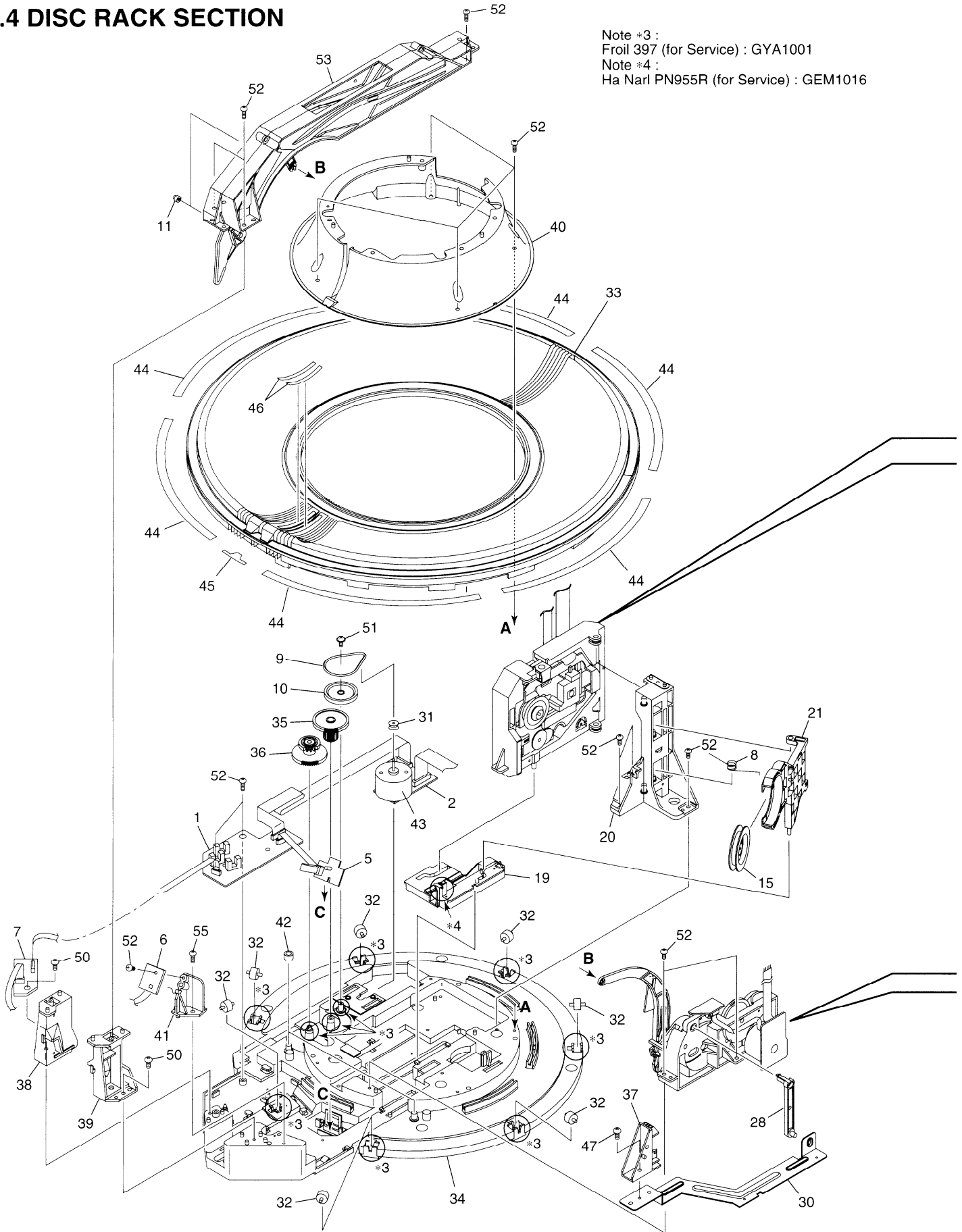

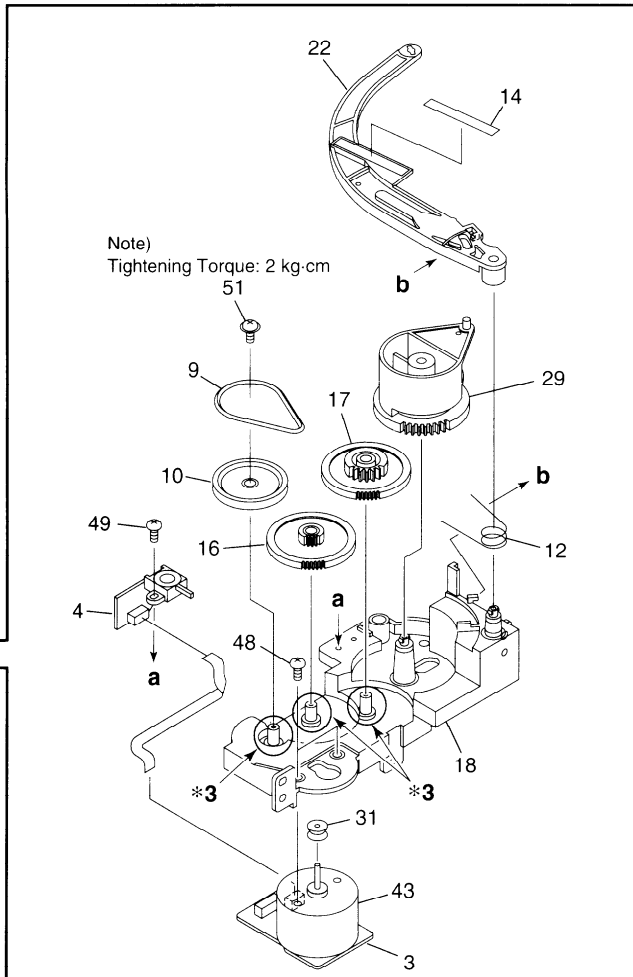
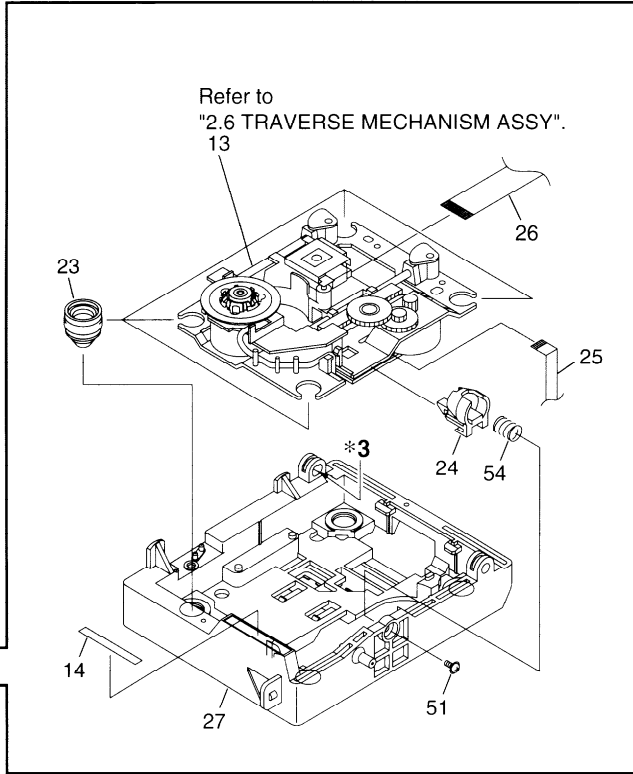

● DISC RACK SECTION PARTS LIST

Mark	No.	Description	Part No.
NSP	1	SSRB Assy	VWG2113
NSP	2	SEMB Assy	VWG2114
NSP	3	LOMB Assy	VWG2115
NSP	4	LOSB Assy	VWG2116
NSP	5	RADB Assy	VWG2117
NSP	6	PHOB Assy	VWG2118
NSP	7	VOLB Assy	VWG2123
	8	Clamp Spring	VBH1318
	9	Loading Belt	AEB7029
	10	Gear Pulley (B)	ANW7062
	11	Roller B	ANW7075
	12	Drive Arm Spring	PBH1226
	13	Traverse Mechanism Assy	VWT1161
	14	Sheet 301	PED1028
	15	Clamper Assy 301	VXA2382
	16	Gear 1	PNW2819
	17	Gear 2	PNW2820
	18	Gear Holder	PNW2822
	19	Slider Cam	PNW2823
	20	Clamp Pole	PNW2826
	21	Clamper Holder	PNW2827
	22	Drive Arm	PNW2829
	23	Float Rubber A	AEB7063
	24	Balancer	VNL1842
	25	Flexible Cable (8P)	VDA1785
	26	Flexible Cable (24P)	VDA1780
	27	Float Base	VNL1841
	28	Link L	PNW2844
	29	Drive Cam	PNW2873
	30	Lock Plate	PNA2438
	31	Motor Pulley	PNW1634
	32	Roller	PNW2647
	33	Disc Rack	PNW2790
	34	Rack Base	PNW2835
	35	ST Gear 0.6	PNW2836
	36	ST Gear 1.0	PNW2837
	37	Disc Divider	PNW2838
	38	Guide Support L	PNW2839
	39	Guide Support R	PNW2840
	40	Disc Guard	PNW2841
	41	Sensor Stay	PNW2842
	42	Guide Roller	PNW2843
	43	Carriage Motor (SELECT, LOADING)	VXM1033
	44	Rack Label	PAM1770
	45	S Label	PAM1771
	46	+1 Label	PRW1507
	47	Screw	BBZ30P080FZK
	48	Screw	BMZ26P040FZK
	49	Screw	BPZ26P060FMC
	50	Screw	BPZ30P100FCU
	51	Screw	IPZ20P080FMC
	52	Screw	PPZ30P080FMC
	53	Arm Assy	PXA1615
	54	Float Spring	VBH1319
	55	Screw	IPZ30P080FMC

2.5 FRONT PANEL SECTION

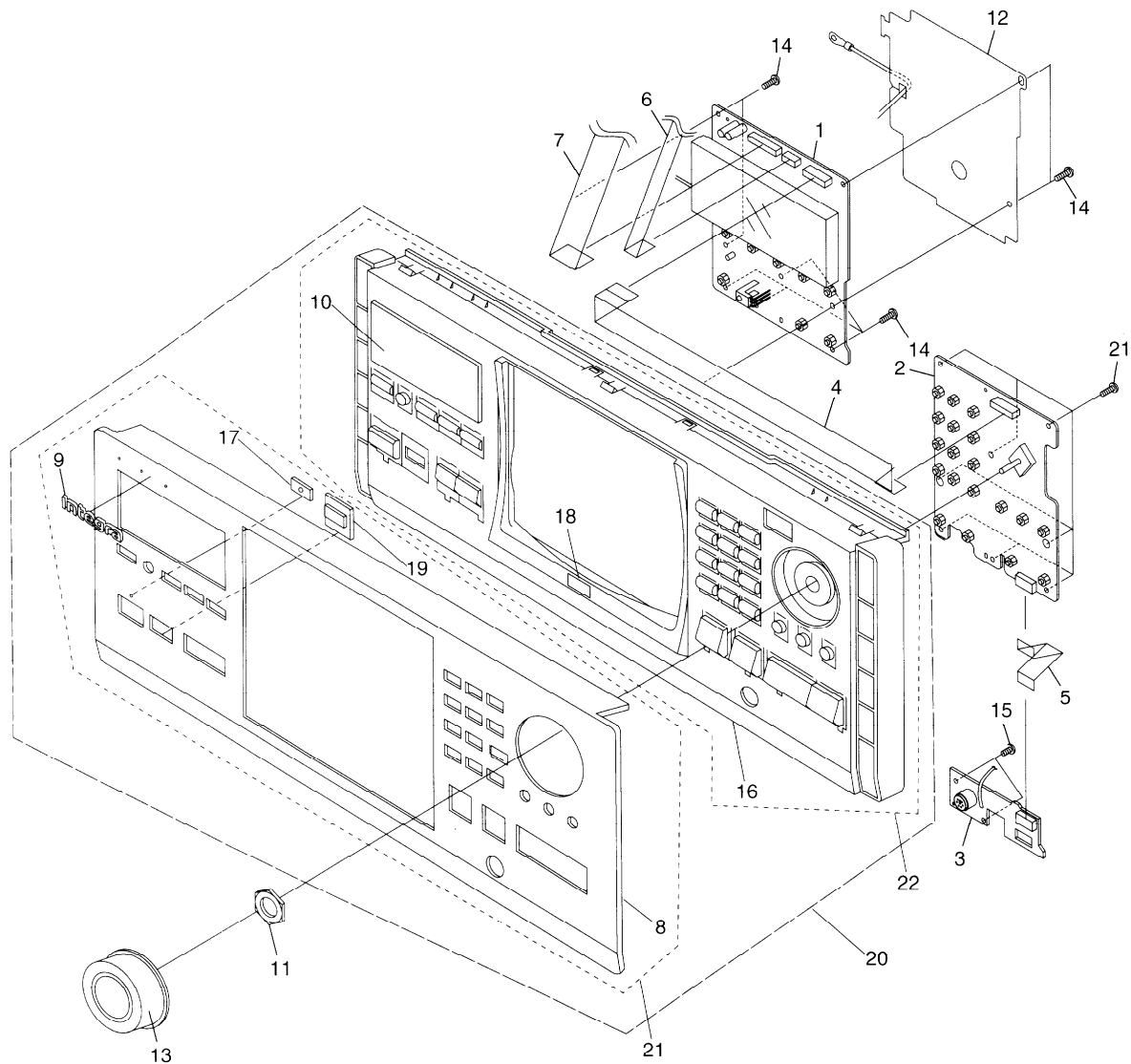

(1) FRONT PANEL SECTION PARTS LIST

Mark	No.	Description	Part No.	Mark	No.	Description	Part No.
NSP	1	FLKY Assy	VWG2126	11	Nut	NK70FMC	
	2	KEYB Assy	VWG2147	12	ISO PLT	28175260A	
	3	PS2B Assy	VWG2125	13	KNOB	28325743A	
	4	Flexible Cable (11P)	VDA1839	14	Screw	PPZ30P100FMC	
	5	Flexible Cable (7P)	VDA1792	15	Screw	PPZ30P050FMC	
	6	Flexible Cable (7P)	VDA1786	16	F Bracket	27111157B	
	7	Flexible Cable (15P)	VDA1775	17	FACET	28198846	
	8	F Panel	27212220	18	PLATE (DVD)	27262640A	
	9	Badge	28135278	19	CLEAR PLT (RE)	28191879	
	10	CLEAR PLT	28191878	20	FRONT AS	27212225A	
			21	F Panel AS	27212190		
			22	F Bracket AS	27111159B		

2.6 TRAVERSE MECHANISM ASSY

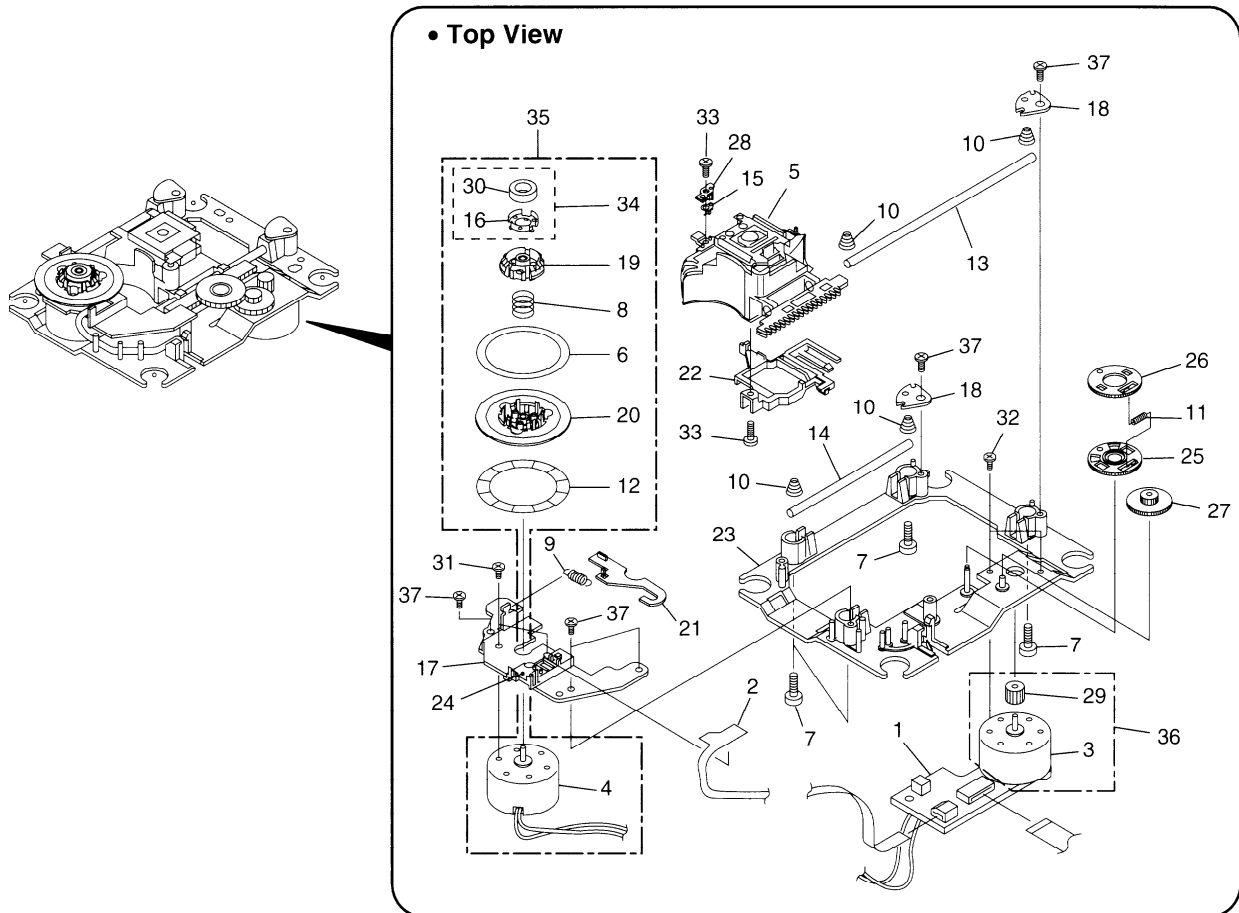

● TRAVERSE MECHANISM ASSY PARTS LIST

Mark	No.	Description	Part No.	Mark	No.	Description	Part No.
NSP	1	SMEB Assy	VWG2048	21	Hook	VNL1770	
NSP	2	FGSB Assy	VWG2009	22	FFC Holder	VNL1802	
	3	Motor	VXM1079	23	Mechanism Base	VNL1806	
	4	Motor	VXM1078	24	FG Holder	VNL1807	
△ NSP	5	Pickup Assy	VWY1055 VXX2653	25	Gear A	VNL1808	
	6	Table Sheet	DEC2040	26	Gear B	VNL1809	
	7	Screw	VBA1058	27	Gear C	VNL1810	
	8	Centering Spring	VBH1278	28	Slider	VNL1811	
	9	Hook Spring	VBH1317	29	Gear D	VNL1814	
	10	Skew Spring	VBH1303	NSP	30	Magnet	VYM1024
	11	Gear Spring	VBH1308	31	Screw	JFZ17P025FZK	
NSP	12	Reflected Sheet	VEC1959	32	Screw	JGZ17P028FMC	
	13	Guide Bar	VLL1504	33	Screw	VBA1051	
	14	Sub-guide Bar	VLL1505	34	Magnet Holder Assy	VXX2507	
	15	Hold Spring	VNC1017	35	Spindle Motor Assy	VXX2649	
NSP	16	Magnet Holder	VNE2070	36	Carriage Motor Assy	VXX2650	
NSP	17	Motor Base	VNE2154	37	Screw	PBA1069	
NSP	18	Cover	VNE2155				
	19	Centering Ring	VNL1746				
NSP	20	Disc Table	VNL1747				

3. BLOCK DIAGRAM AND SCHEMATIC DIAGRAM

3.1 BLOCK DIAGRAM

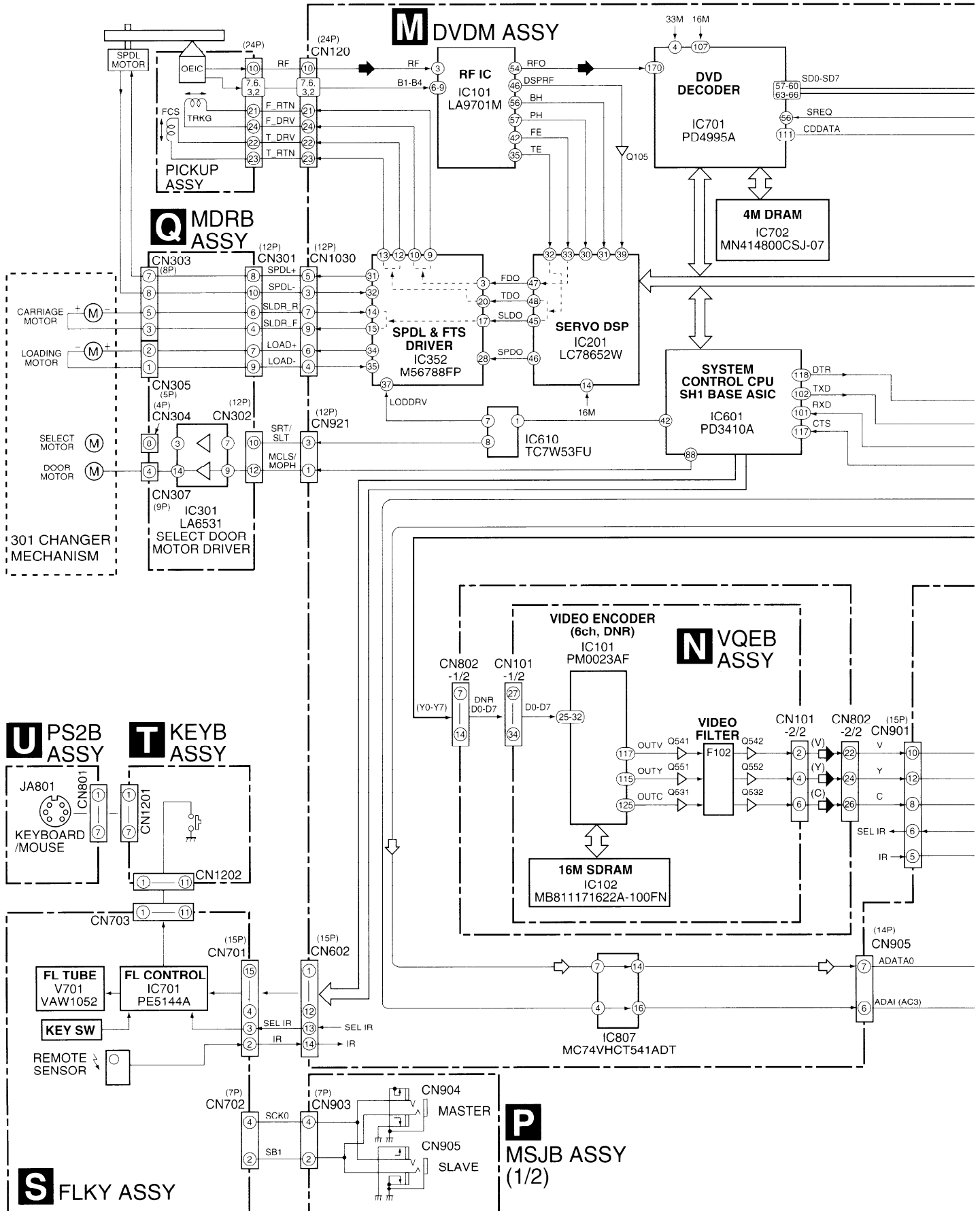

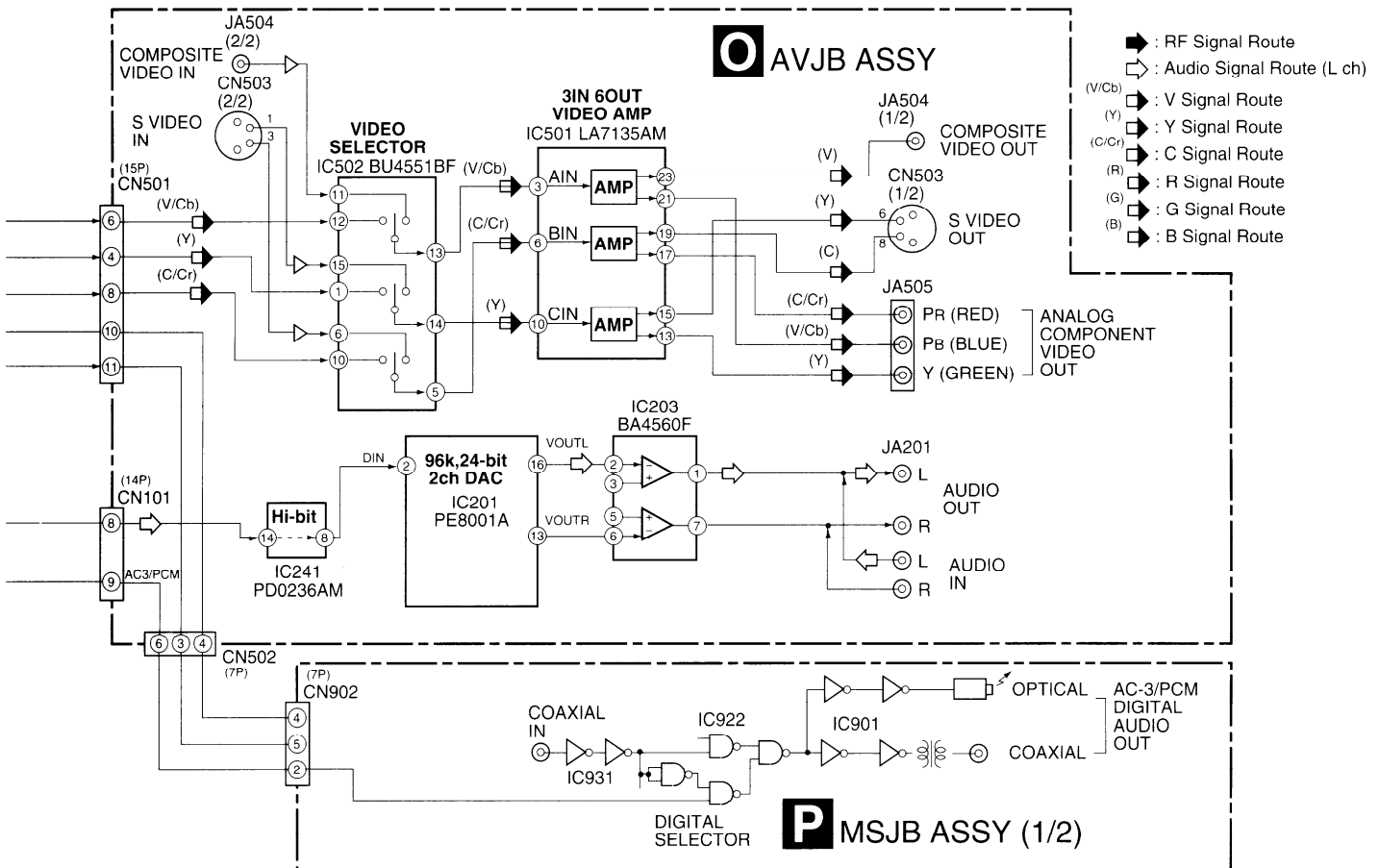
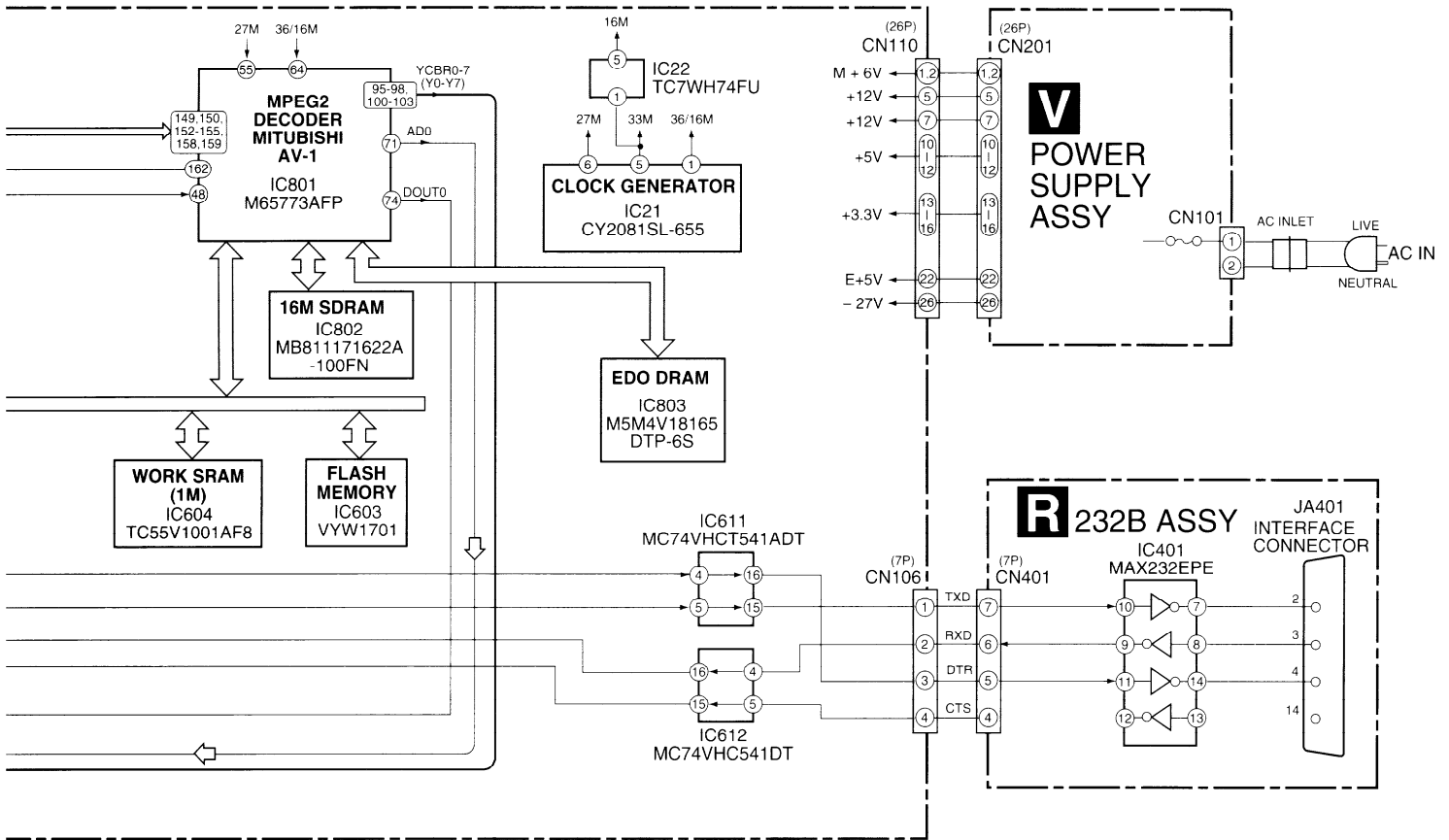

3.2 FGSB, SMEB, SSRB, SEMB, LOMB, LOSB, RADB, PHOB, DOMB, DOSB, VOLB, LEDB, PICKUP ASSYS and OVERALL WIRING DIAGRAM

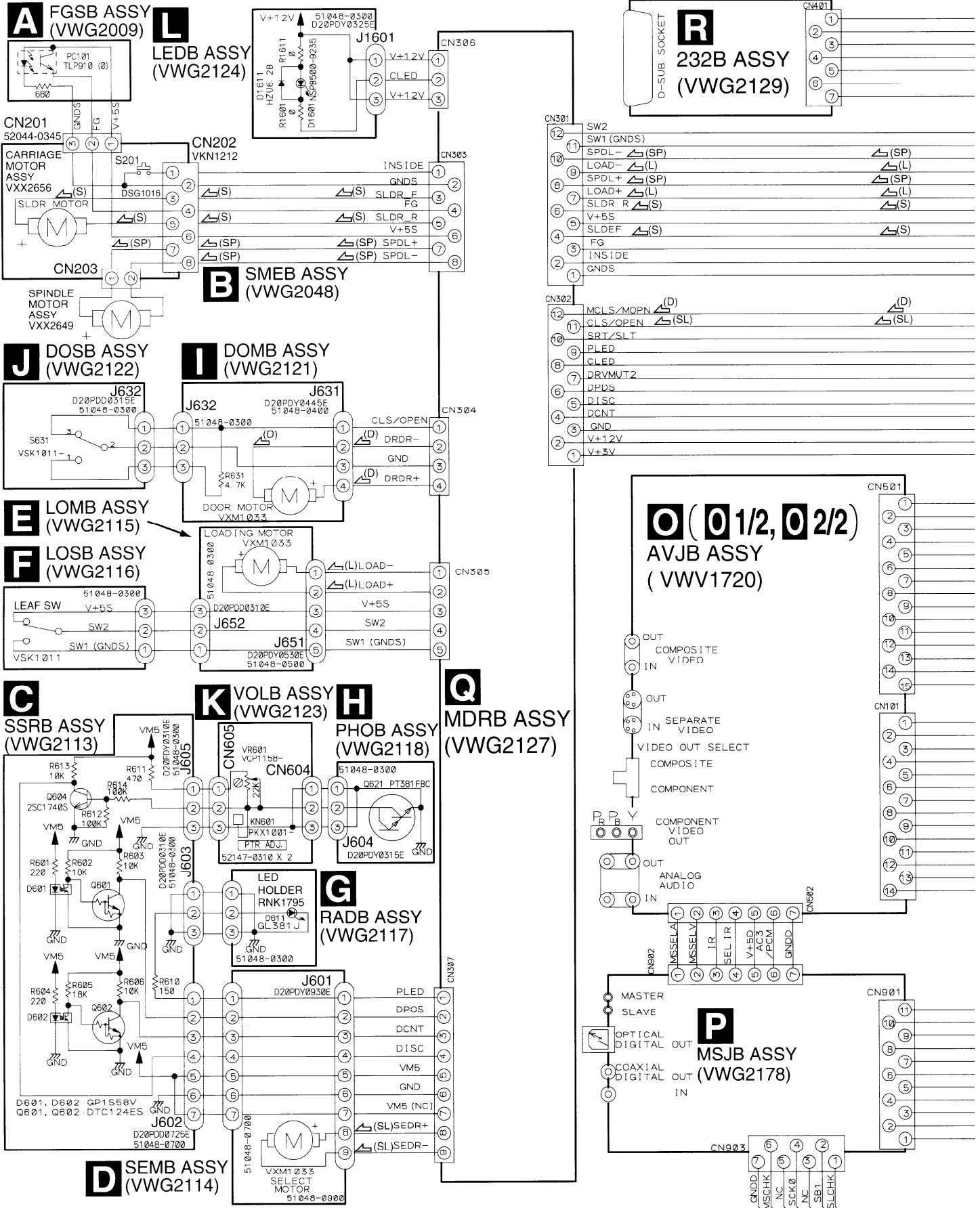

Note : When ordering service parts, be sure to refer to "EXPLODED VIEWS and PARTS LIST" or "PCB PARTS LIST".

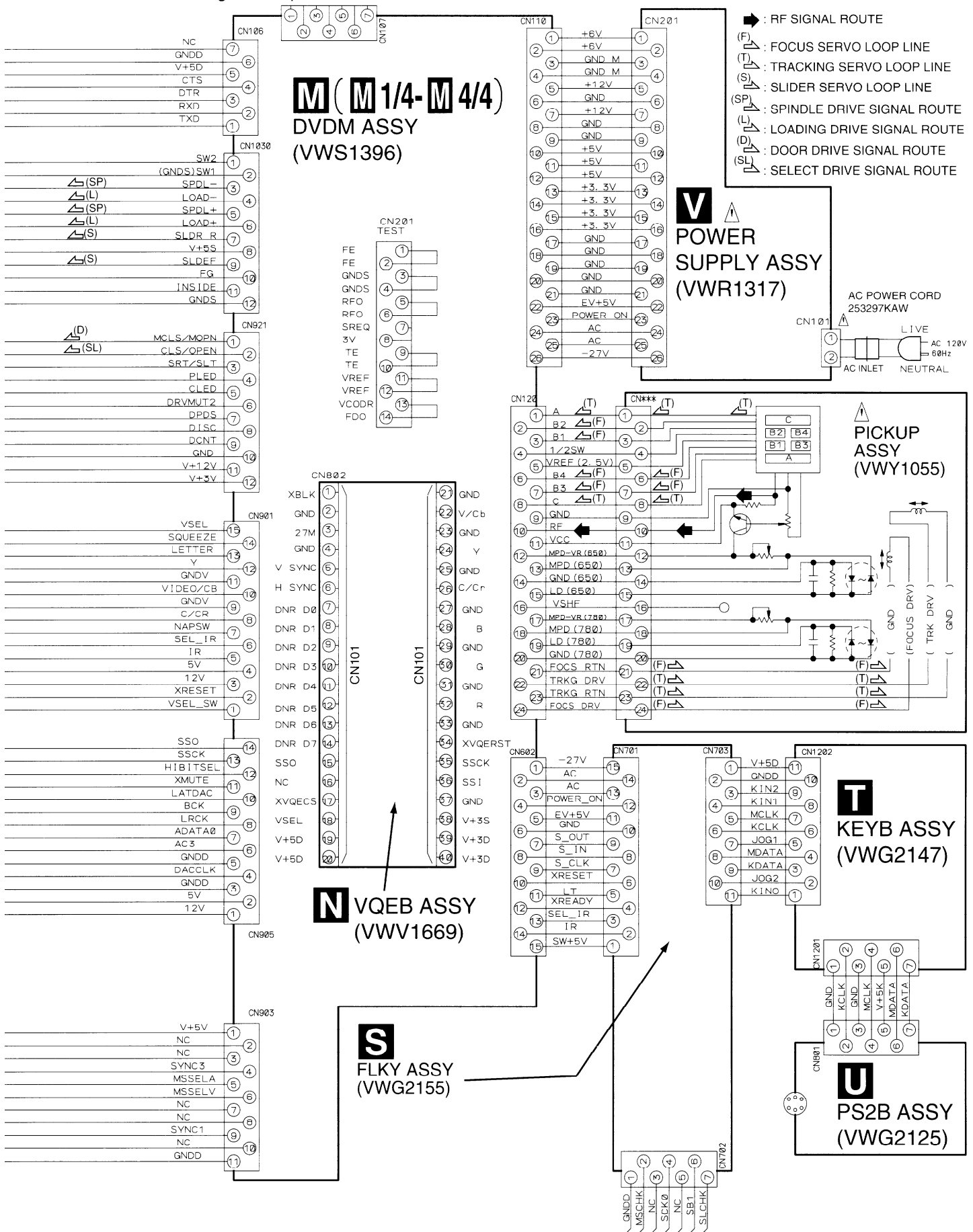

3.3 DVDM ASSY (1/4)

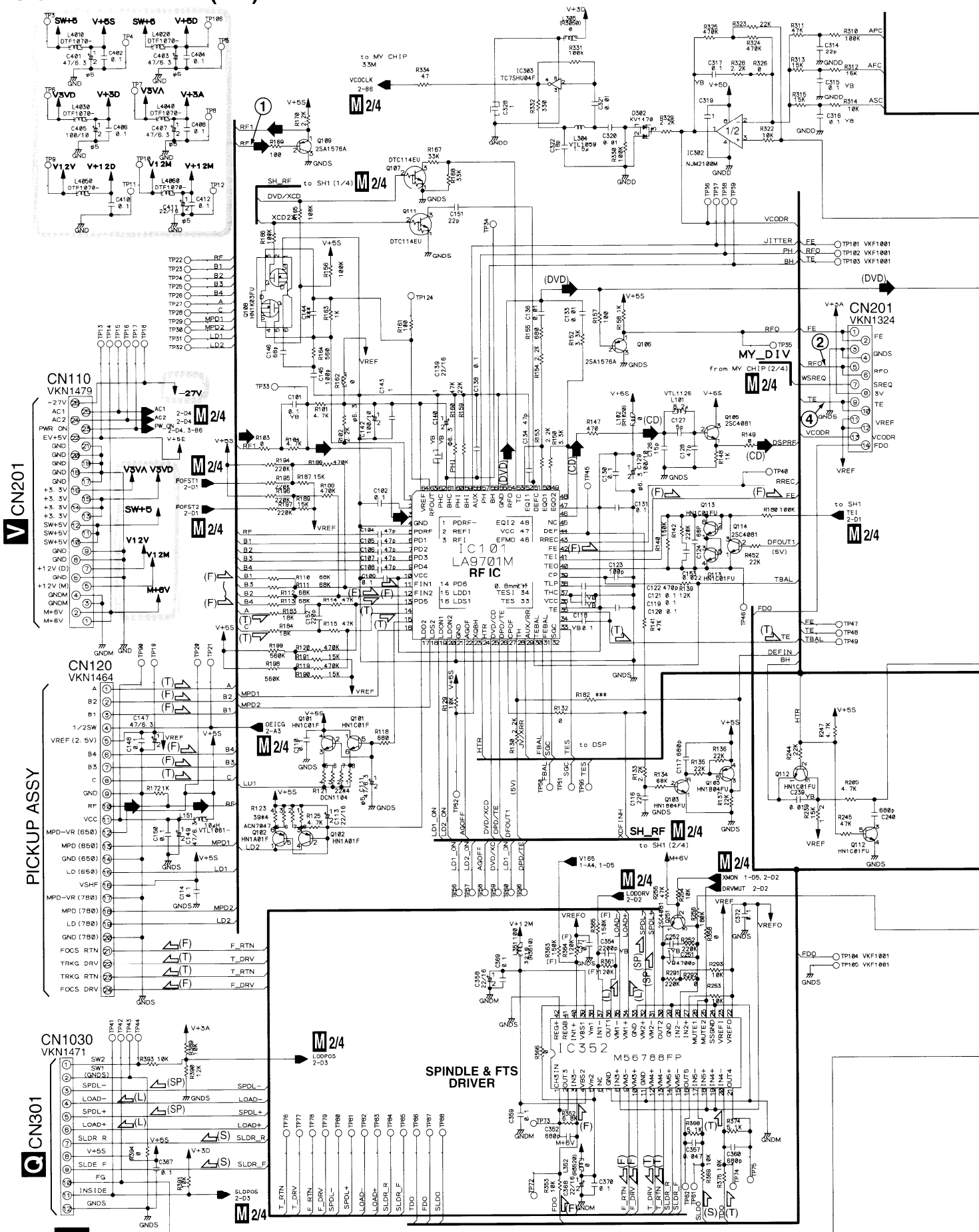

M 1/4 DVDM ASSY (VWS1396)

0 : The power supply is shown with the marked box.

- : RF SIGNAL ROUTE
- : ROM DATA SIGNAL ROUTE
- (F) : FOCUS SERVO LOOP LINE
- (T) : TRACKING SERVO LOOP LINE
- (S) : SLIDER SERVO LOOP LINE
- (SP) : SPINDLE DRIVE SIGNAL ROUTE
- (L) : LOADING DRIVE SIGNAL ROUTE

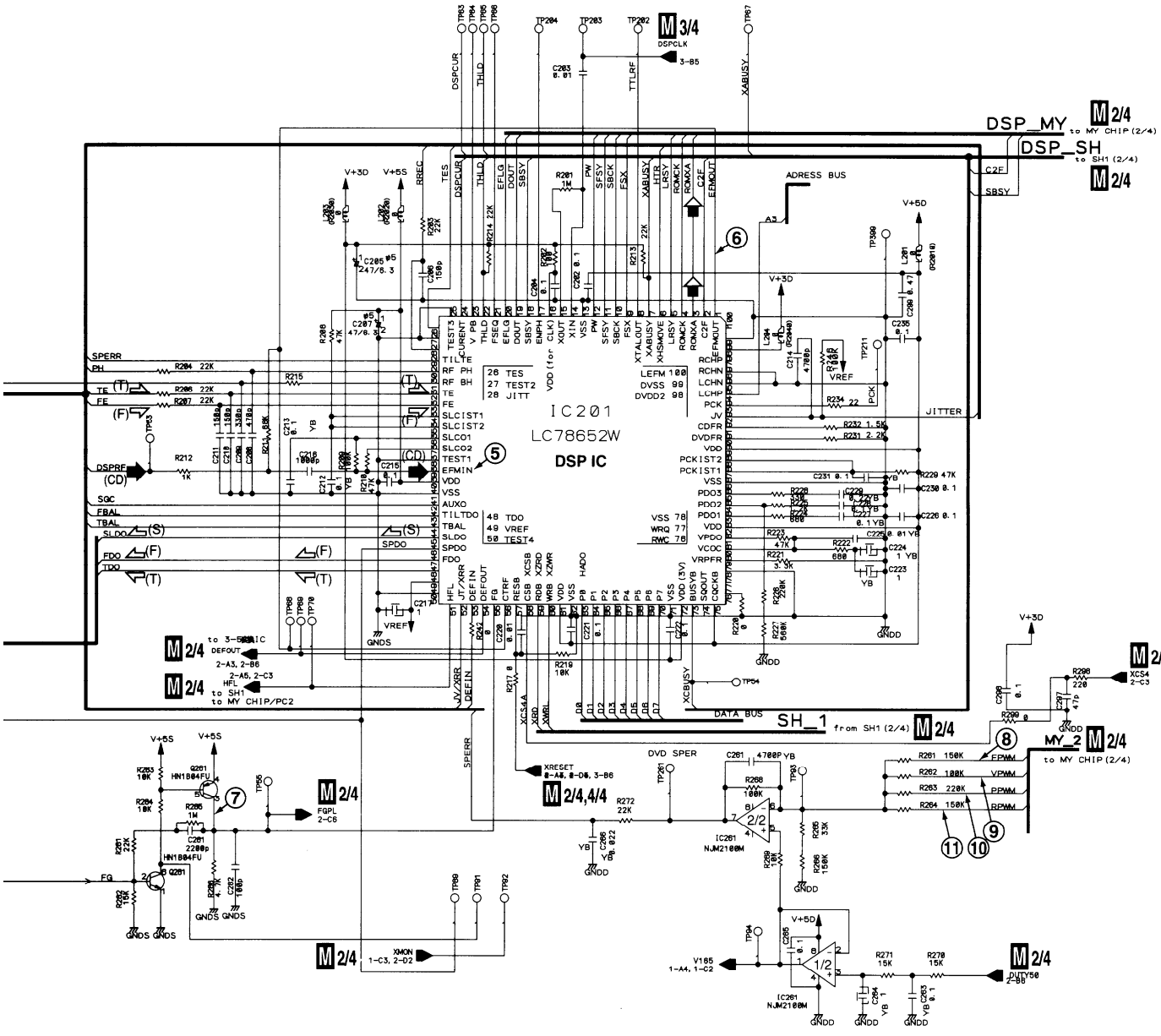
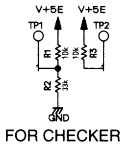
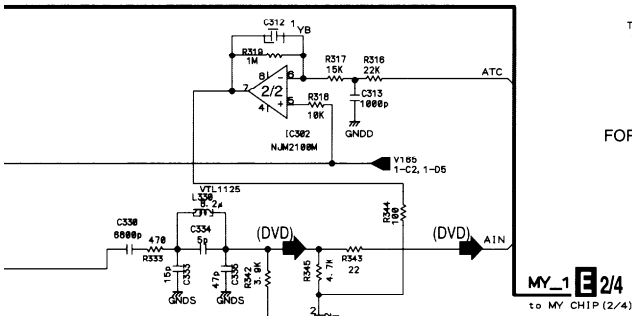

3.4 DVDM ASSY (2/4)

M 2/4 DVDM ASSY (VWS1396)

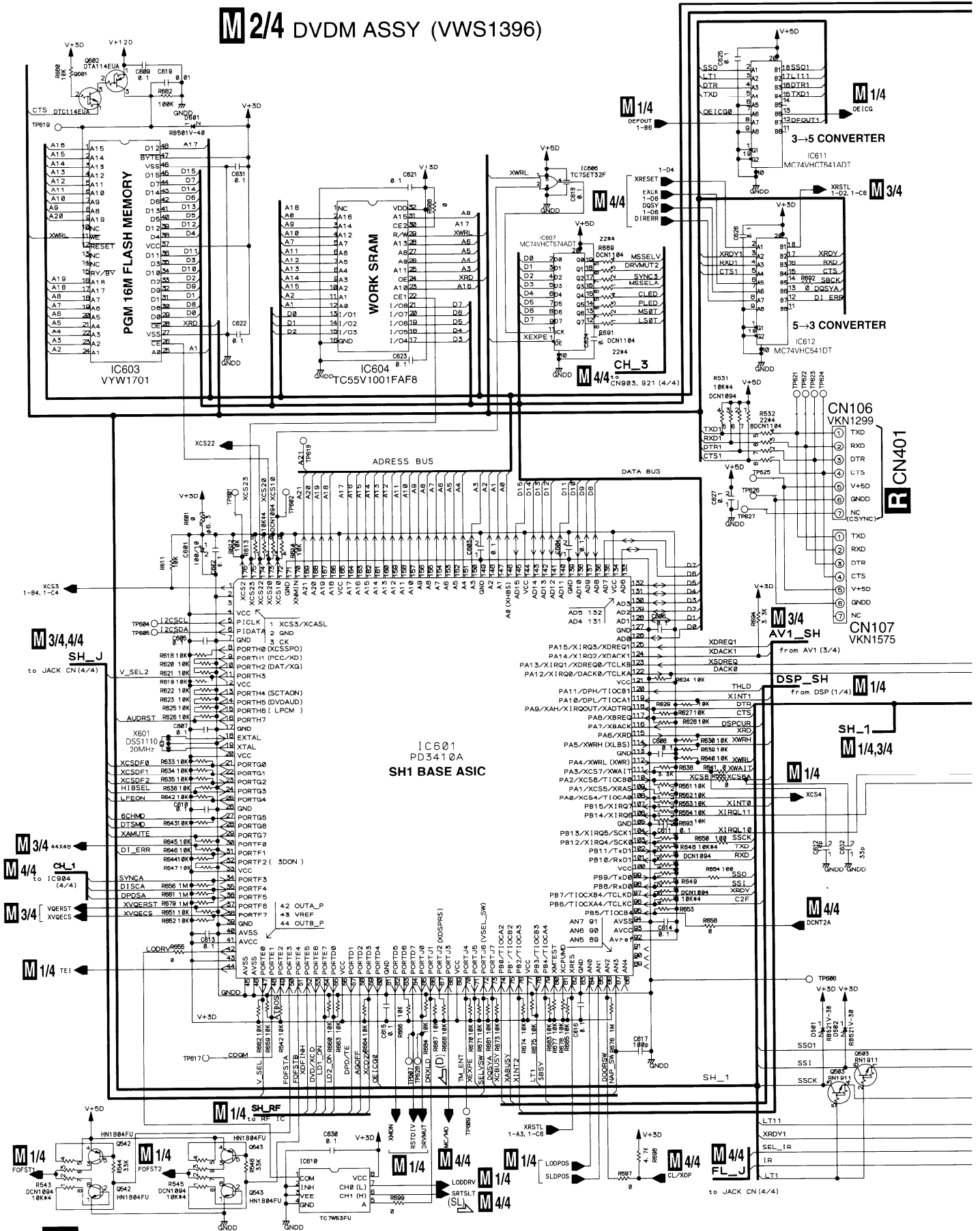

○ : The power supply is shown with the marked box.

- ↪ : AUDIO SIGNAL ROUTE
- ▣ : ROM DATA SIGNAL ROUTE
- (D) : DOOR DRIVE SIGNAL ROUTE
- (SL) : SELECT DRIVE SIGNAL ROUTE

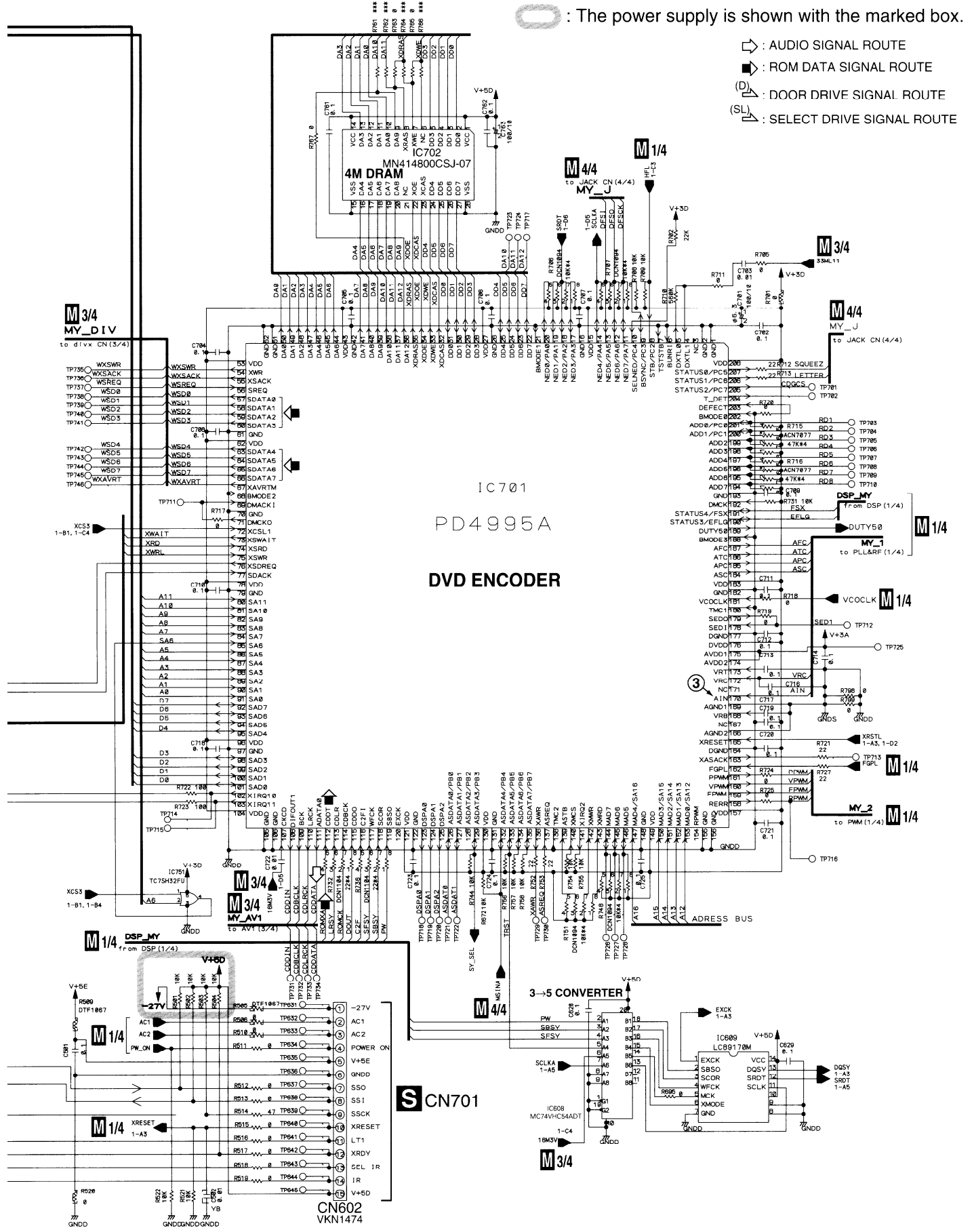

IC701
PD4995A
DVD ENCODER

CN602
VK1474

CN701

3.5 DVDM ASSY (3/4)

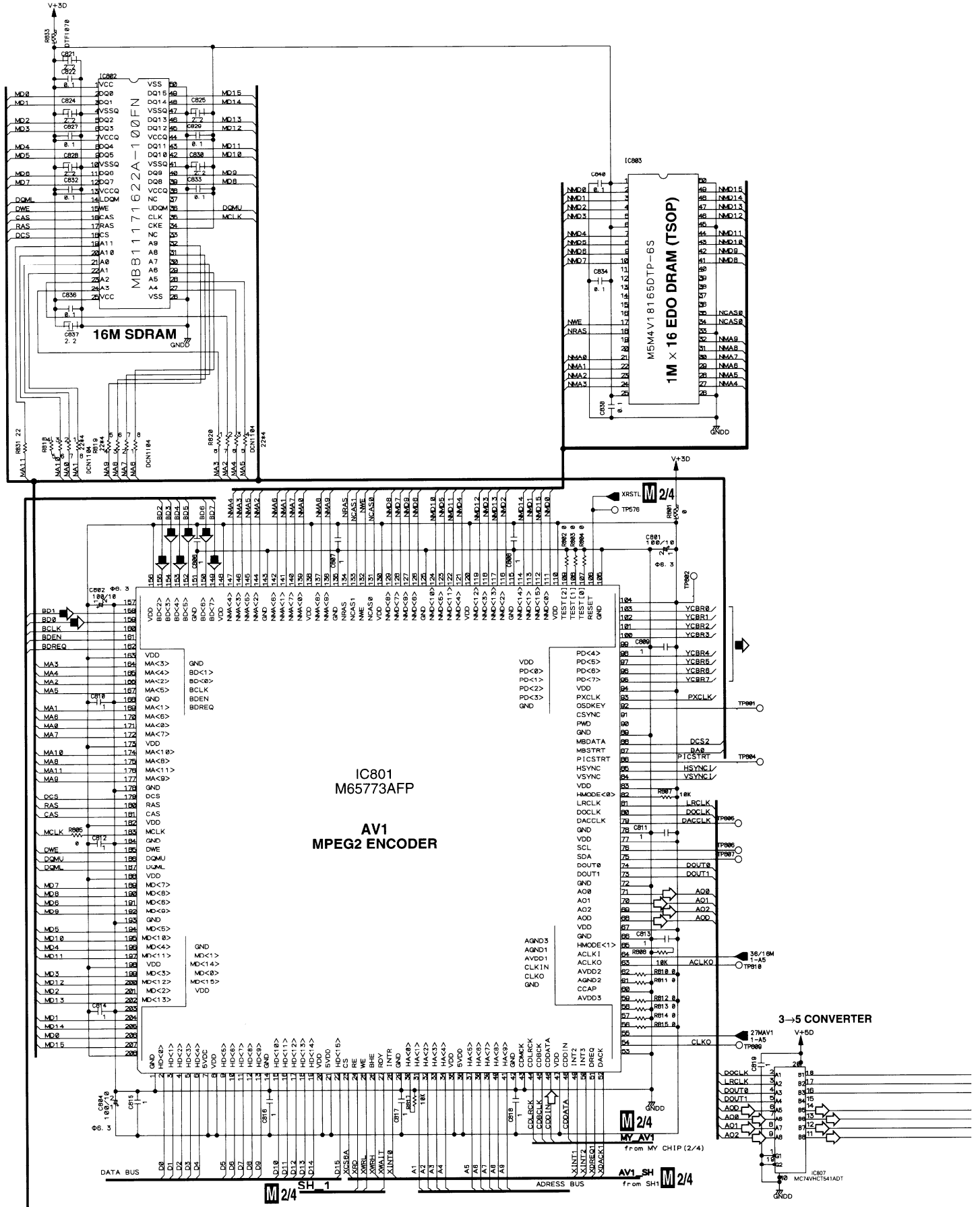

M 3/4 DVDM ASSY (VWS1396)

- ◁ : AUDIO SIGNAL ROUTE
- ▷ : ROM DATA SIGNAL ROUTE
- (V) : VIDEO SIGNAL ROUTE
- (Y) : Y SIGNAL ROUTE
- (C) : C SIGNAL ROUTE

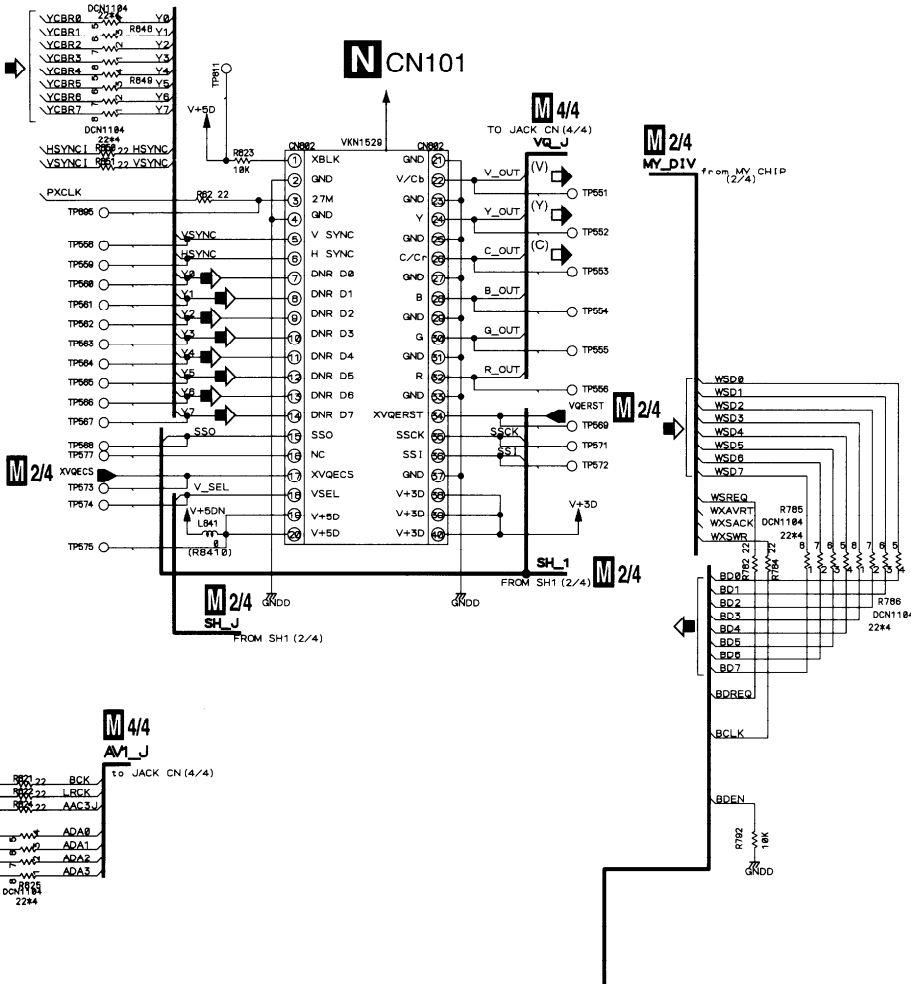
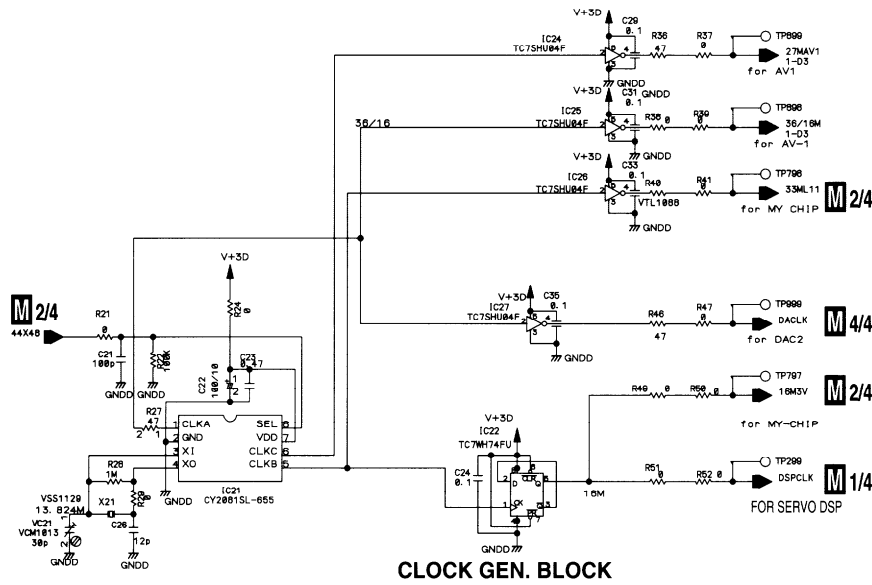

3.6 DVDM ASSY (4/4)

M 4/4 DVDM ASSY (VWS1396)

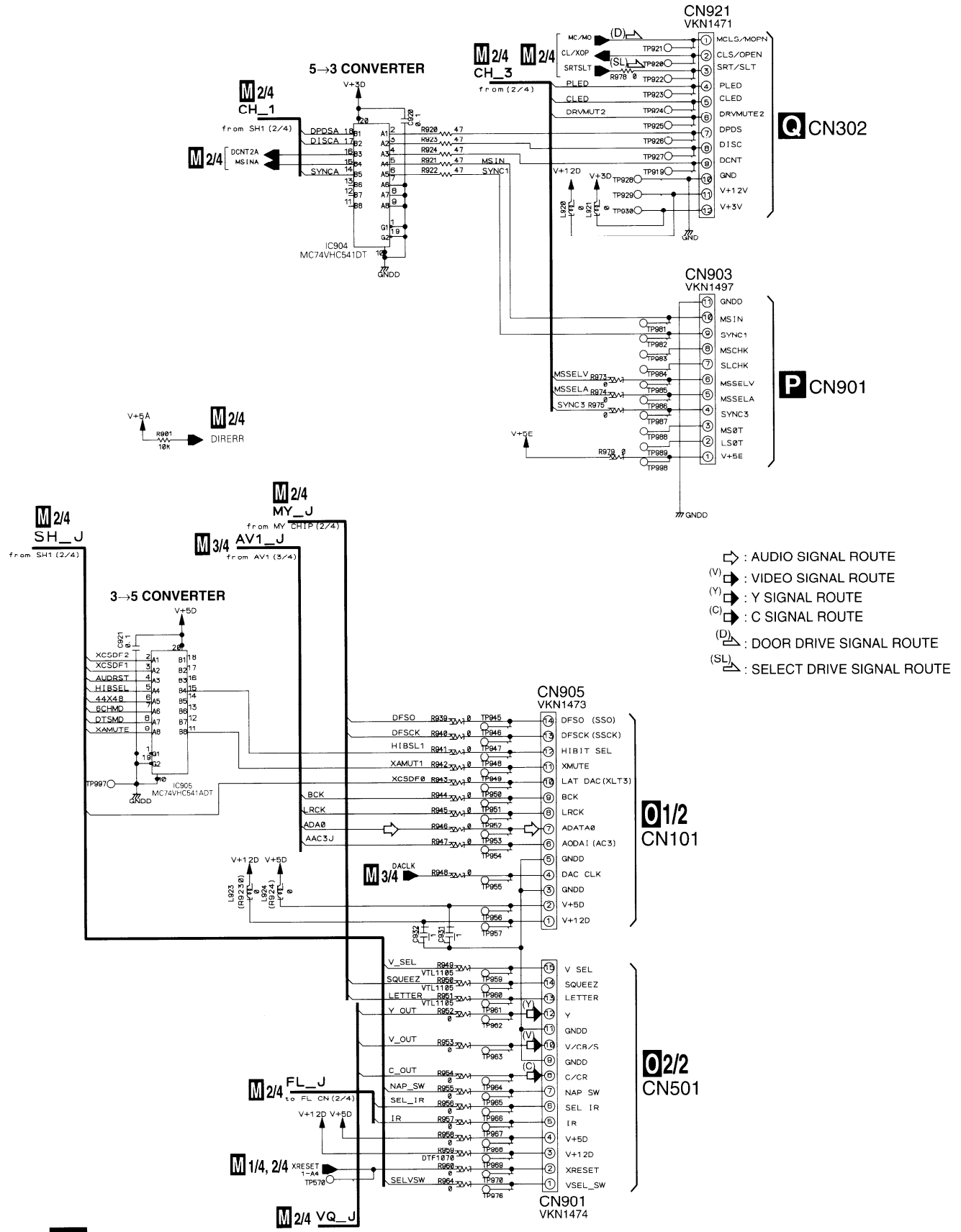

3.7 VQEB ASSY

N VQEB ASSY (VWV1669)

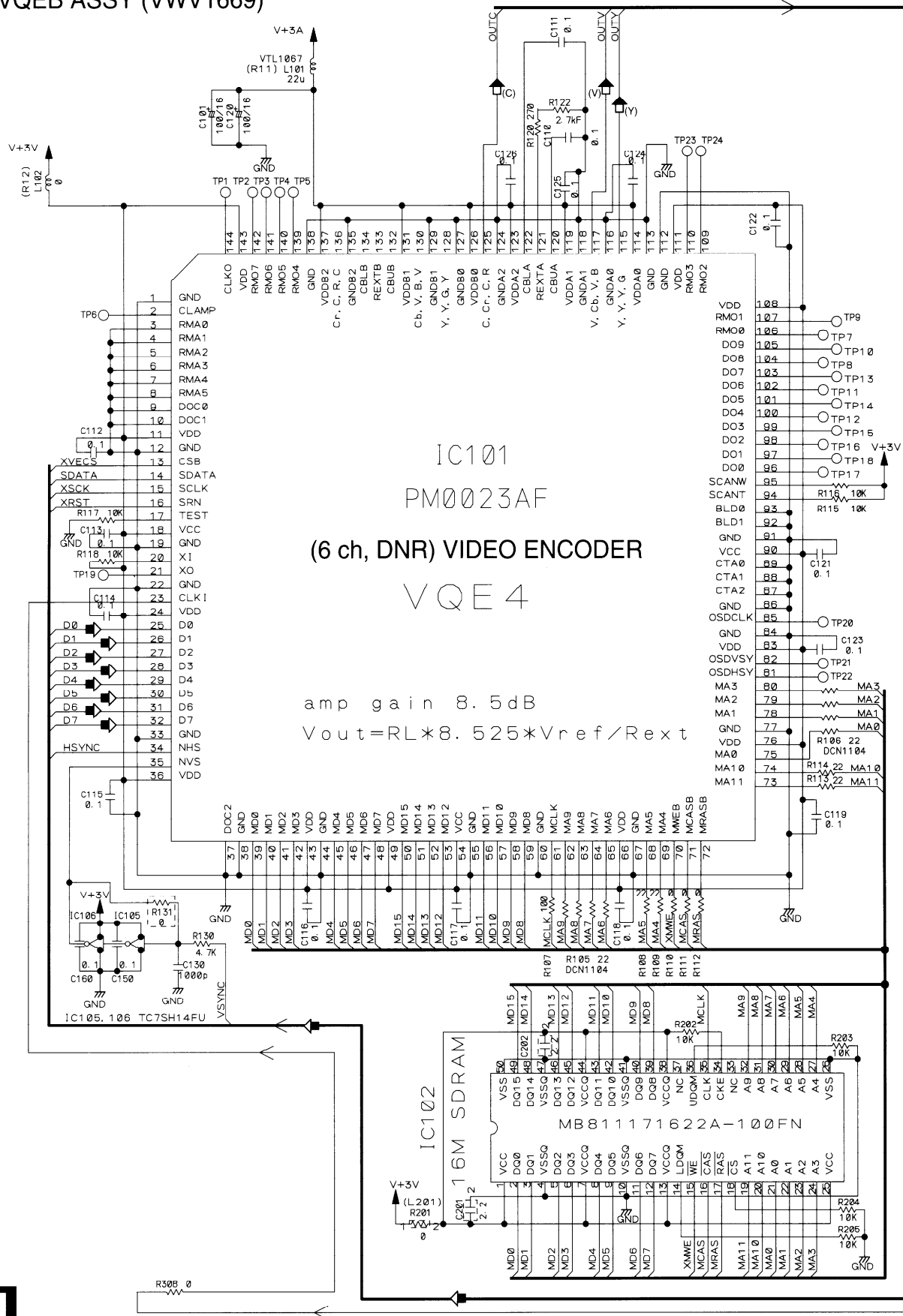

 : The power supply is shown with the marked box.

- ▣ : ROM DATA SIGNAL ROUTE
- (V) : VIDEO SIGNAL ROUTE
- (Y) : Y SIGNAL ROUTE
- (C) : C SIGNAL ROUTE

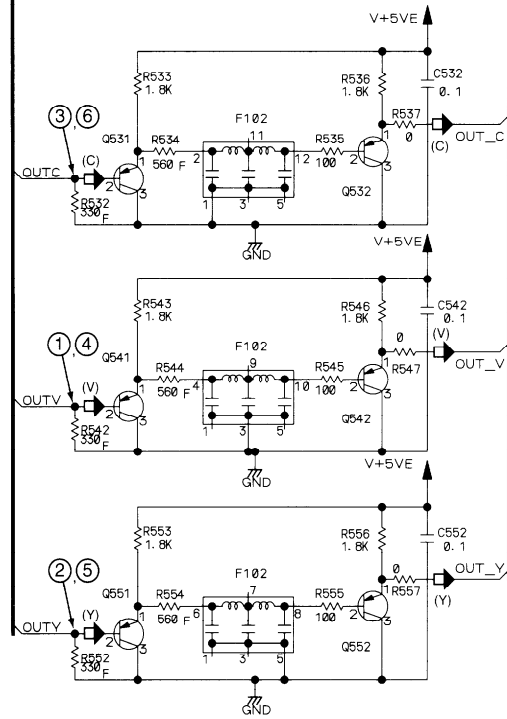

Q531, Q532, Q541, Q542, Q551, Q552 : 2PB709A (QR)
F102 : VTF1155

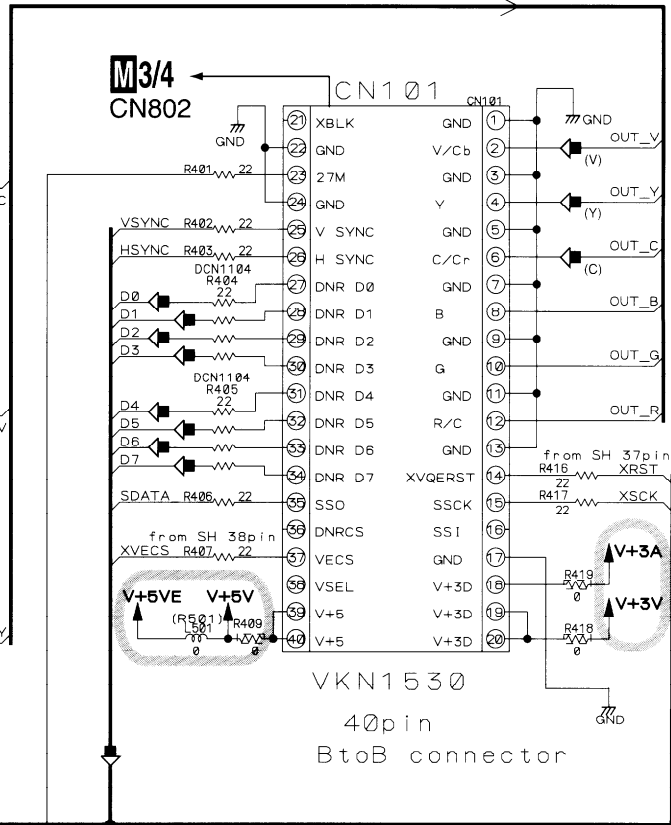



VKN1530
40pin
BtoB connector

3.8 AVJB ASSY (1/2)

0 1/2 AVJB ASSY (VWV1720)

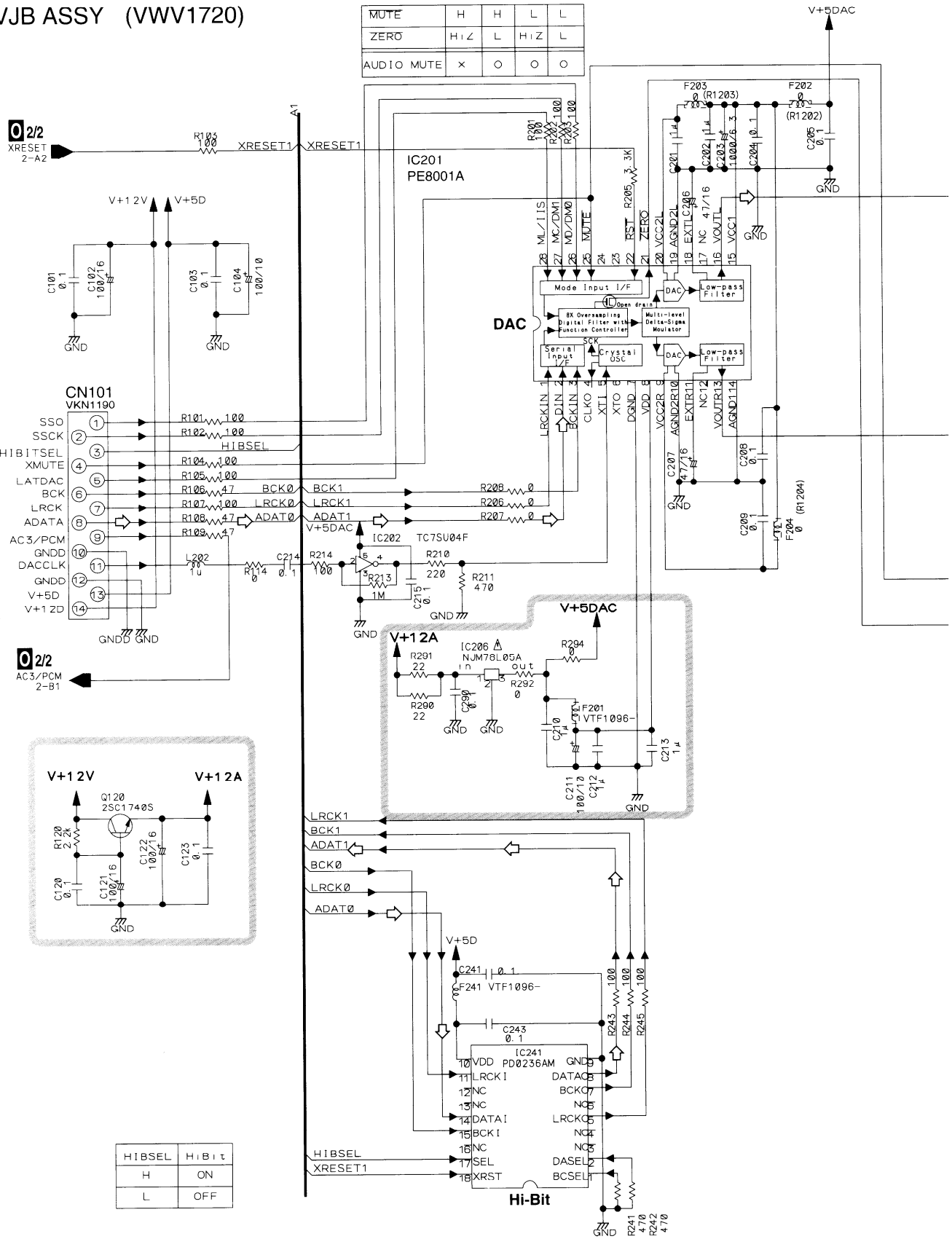
M4/4
CN905



 : The power supply is shown with the marked box.

 : AUDIO SIGNAL ROUTE

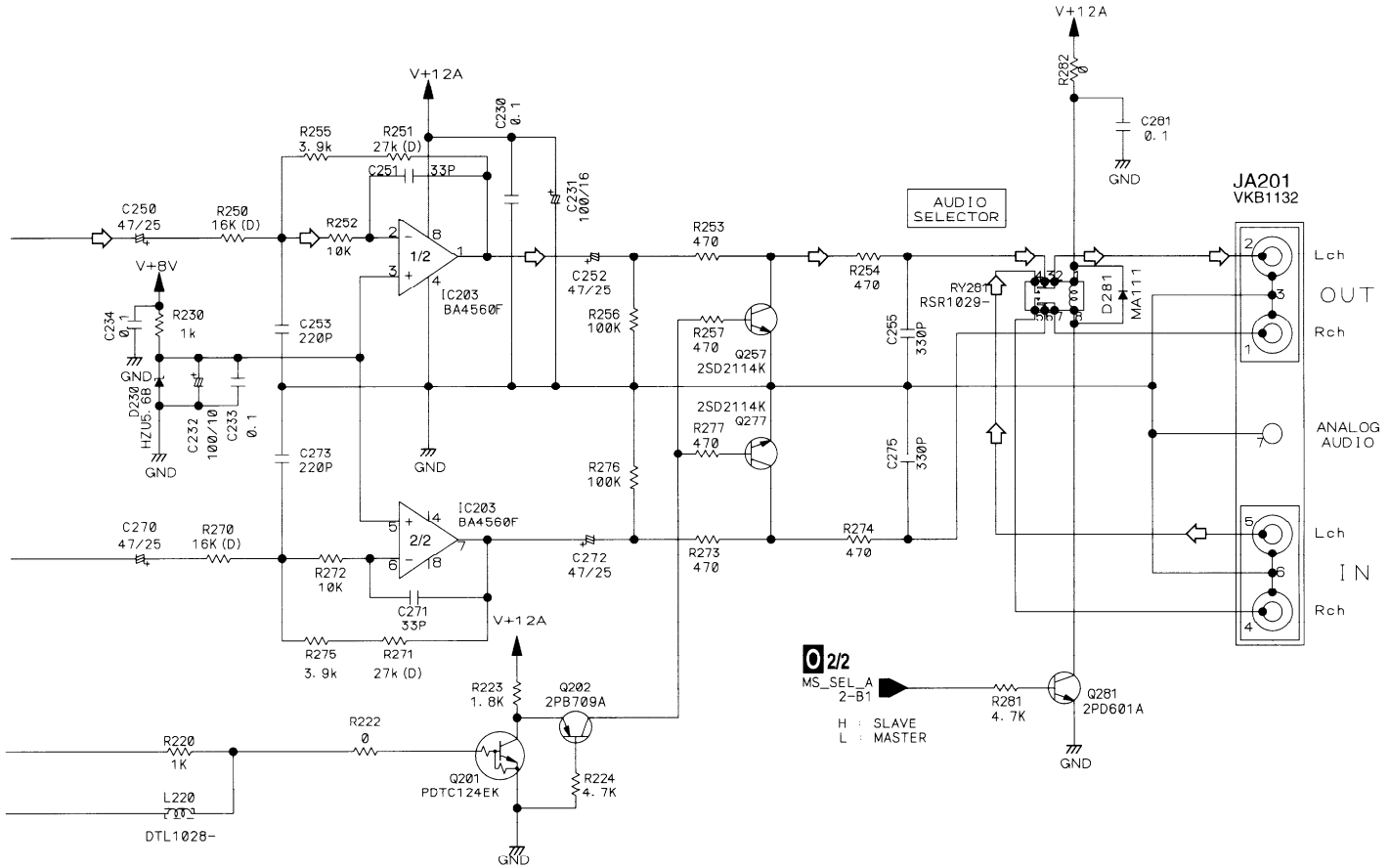

0/2
MS_SEL_A
2-B1
H : SLAVE
L : MASTER

02/2 AVJB ASSY (VWV1719)

(VPb) : VIDEO/PB SIGNAL ROUTE
 (Y) : Y SIGNAL ROUTE
 (C/Pb) : C/PR SIGNAL ROUTE

 : The power supply is shown with the marked box.

	LOW	OPEN	HIGH
AMP SEL	through	6dB	8.5dB 
VSEL1	13, 17, 21 MUTE	NO MUTE	15, 19, 23 MUTE
	Y, C, COMPOSITE OUT	—	COMPONENT OUT

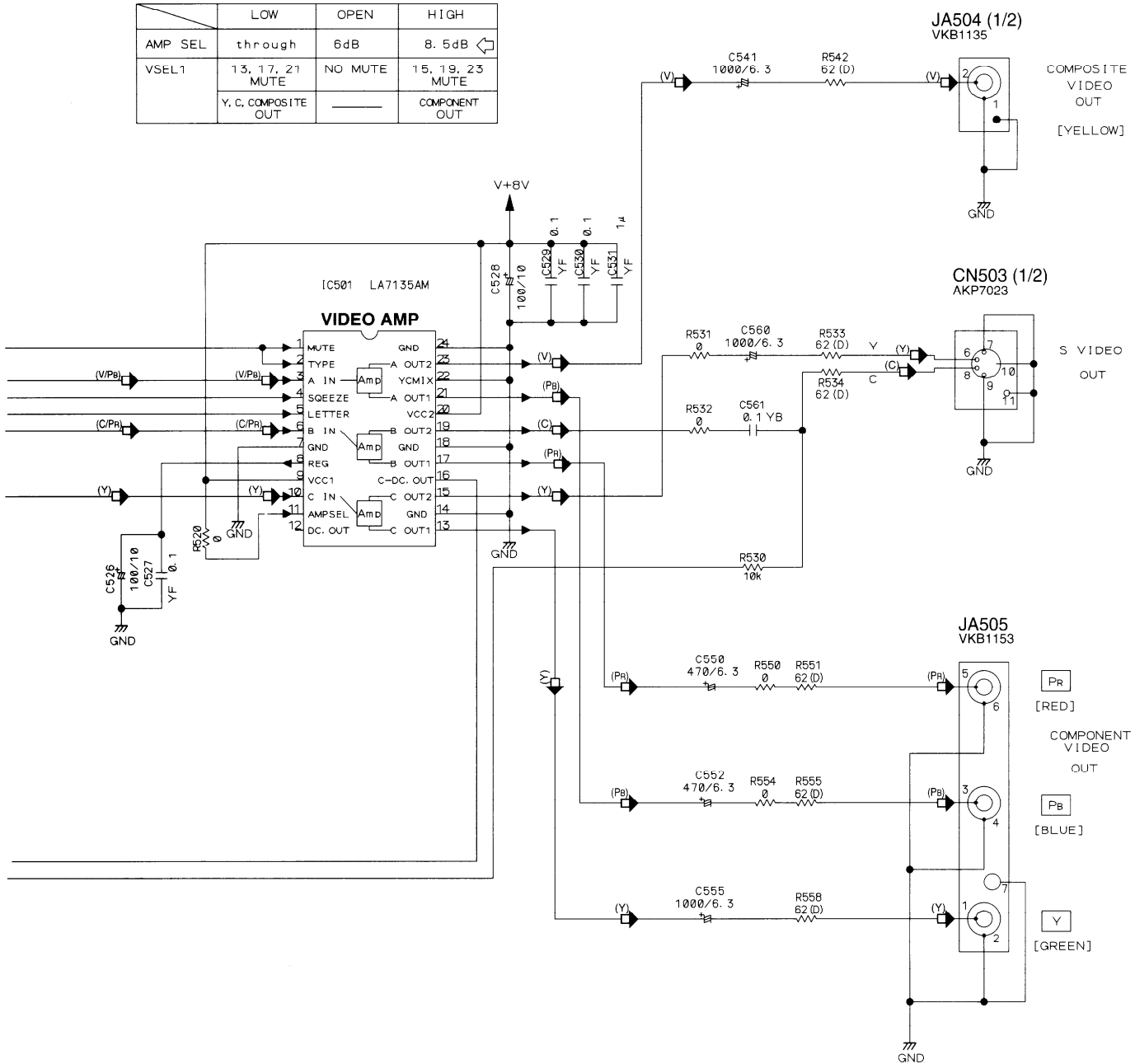

3.10 MSJB ASSY

P MSJB ASSY (VWG2178)

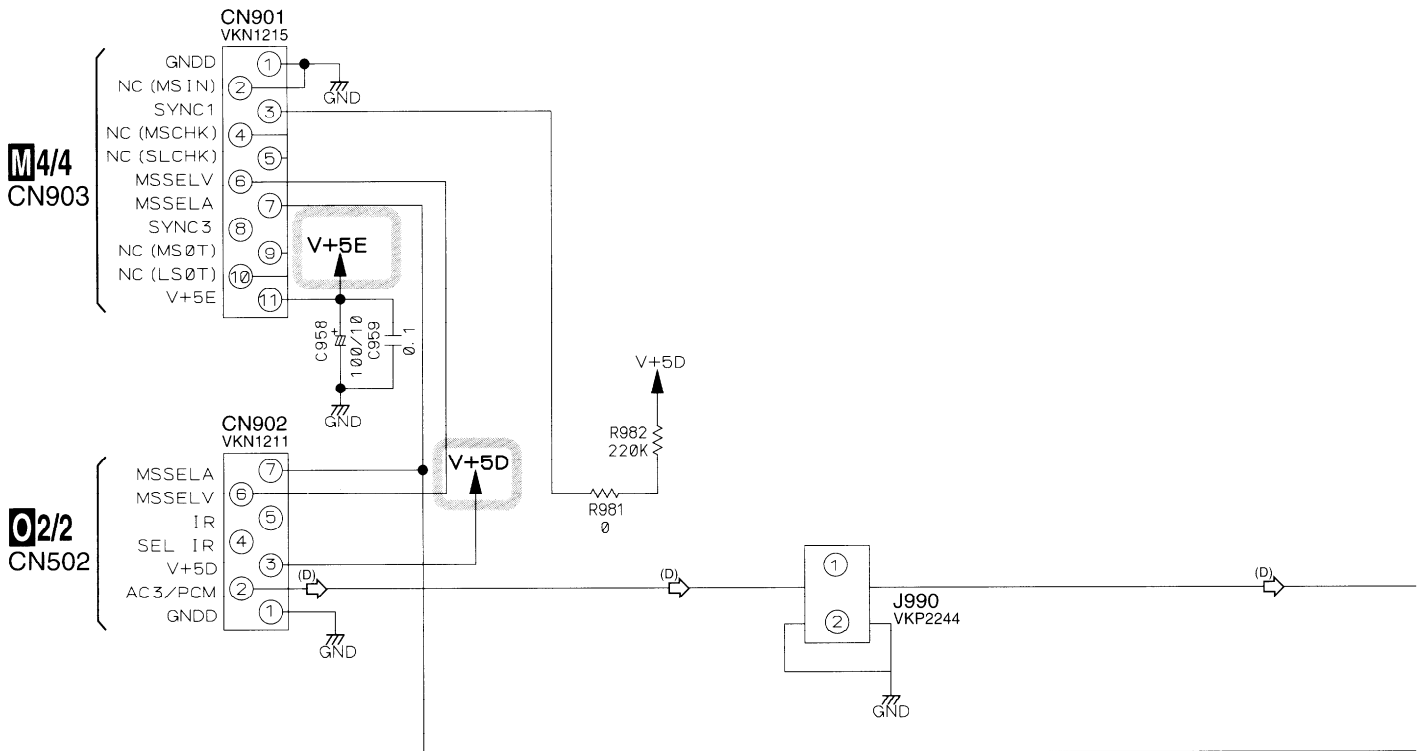
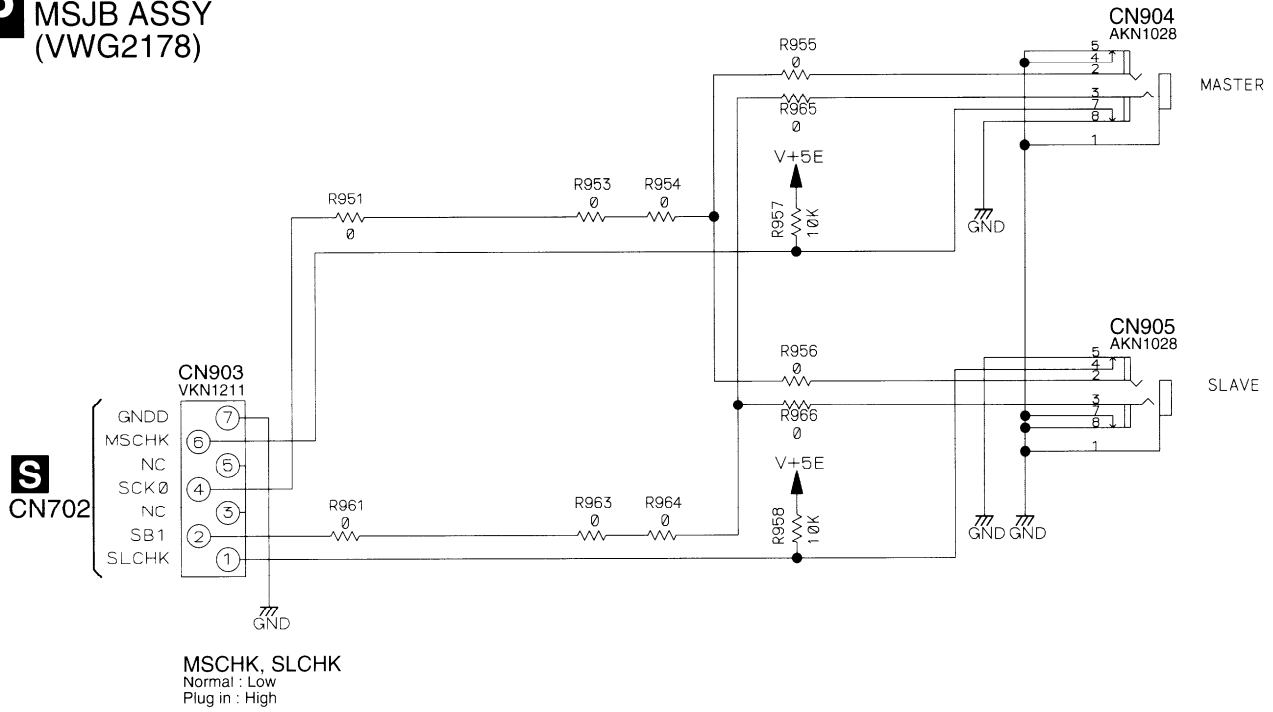

 : The power supply is shown with the marked box.

 : DIGITAL AUDIO SIGNAL ROUTE

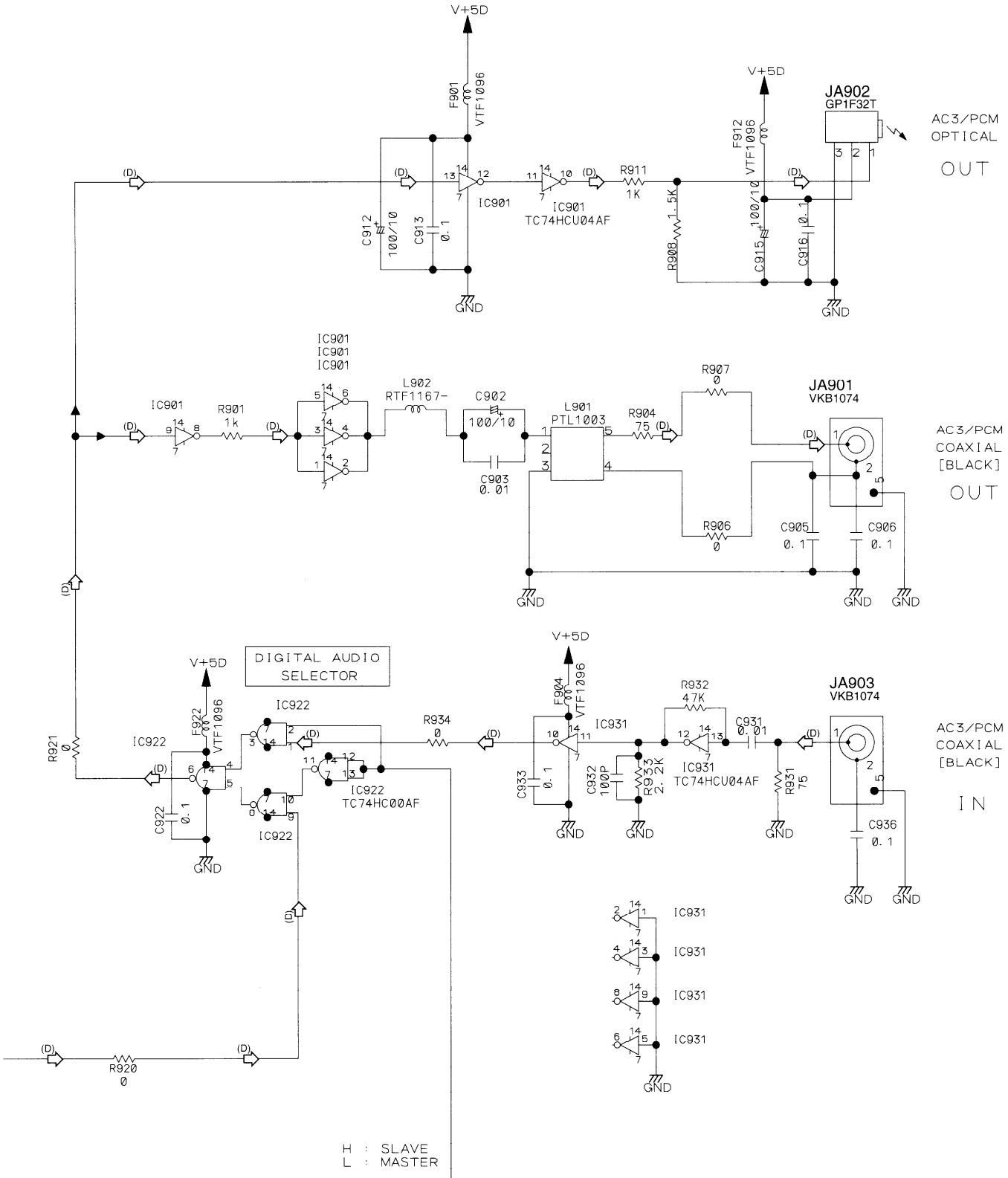

3.11 MDRB ASSY

Q MDRB ASSY (VWG2127)

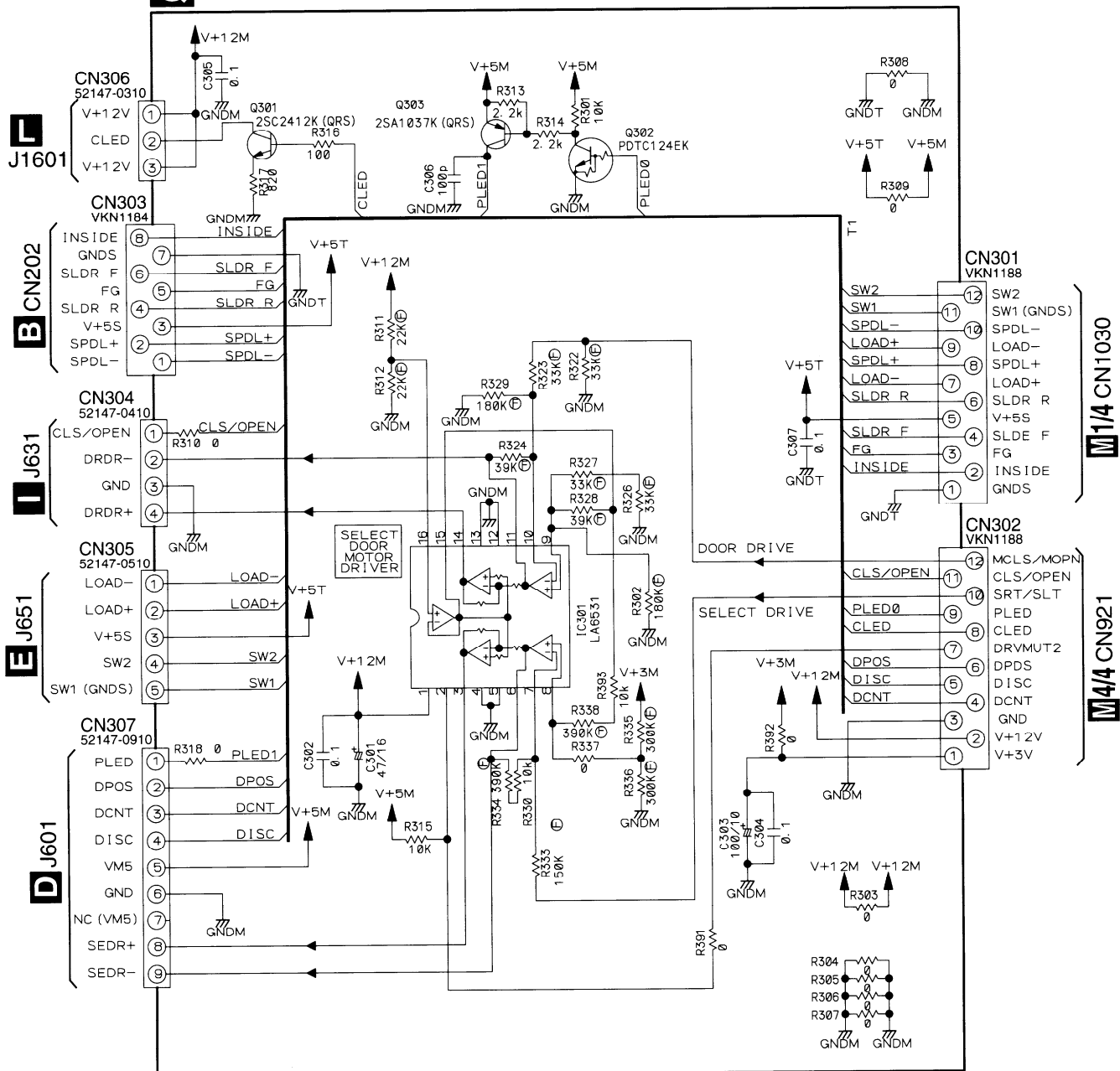

3.12 232B ASSY

R 232B ASSY (VWG2129)

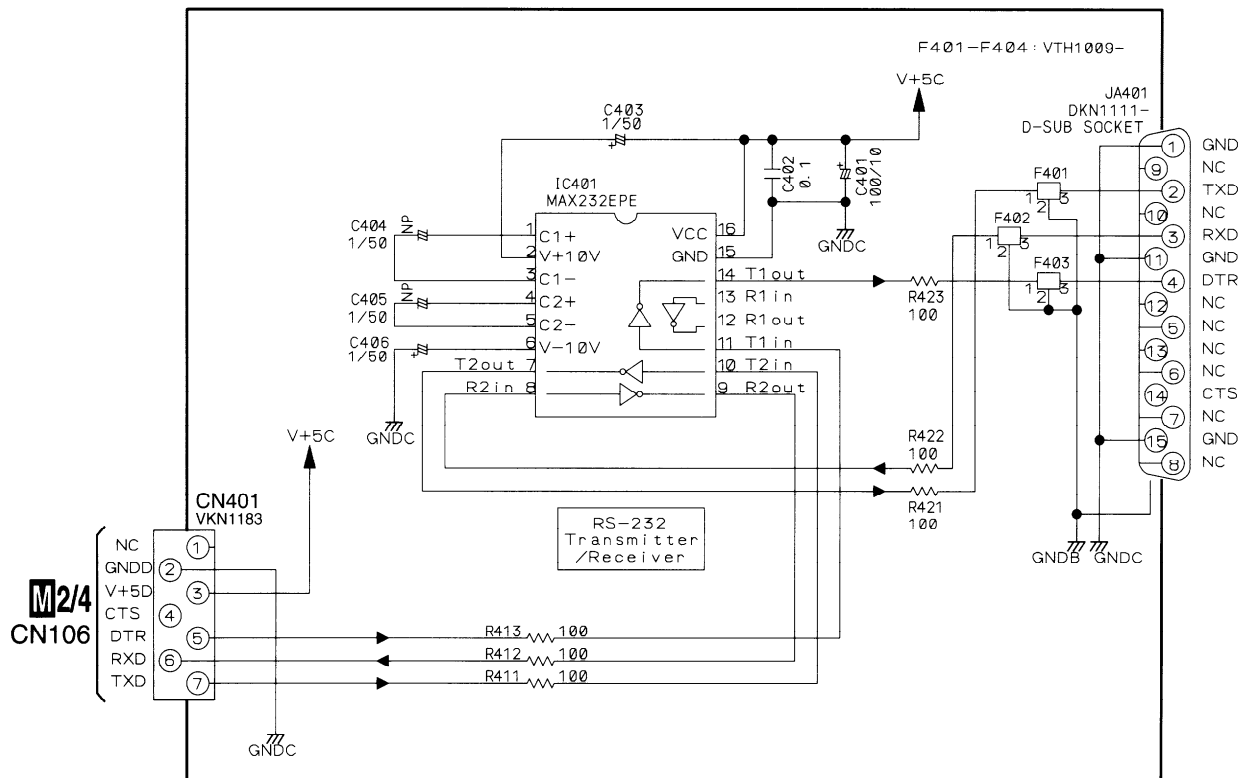

3.13 FLKY, KEYB and PS2B ASSYS

S FLKY ASSY (VWG2155)

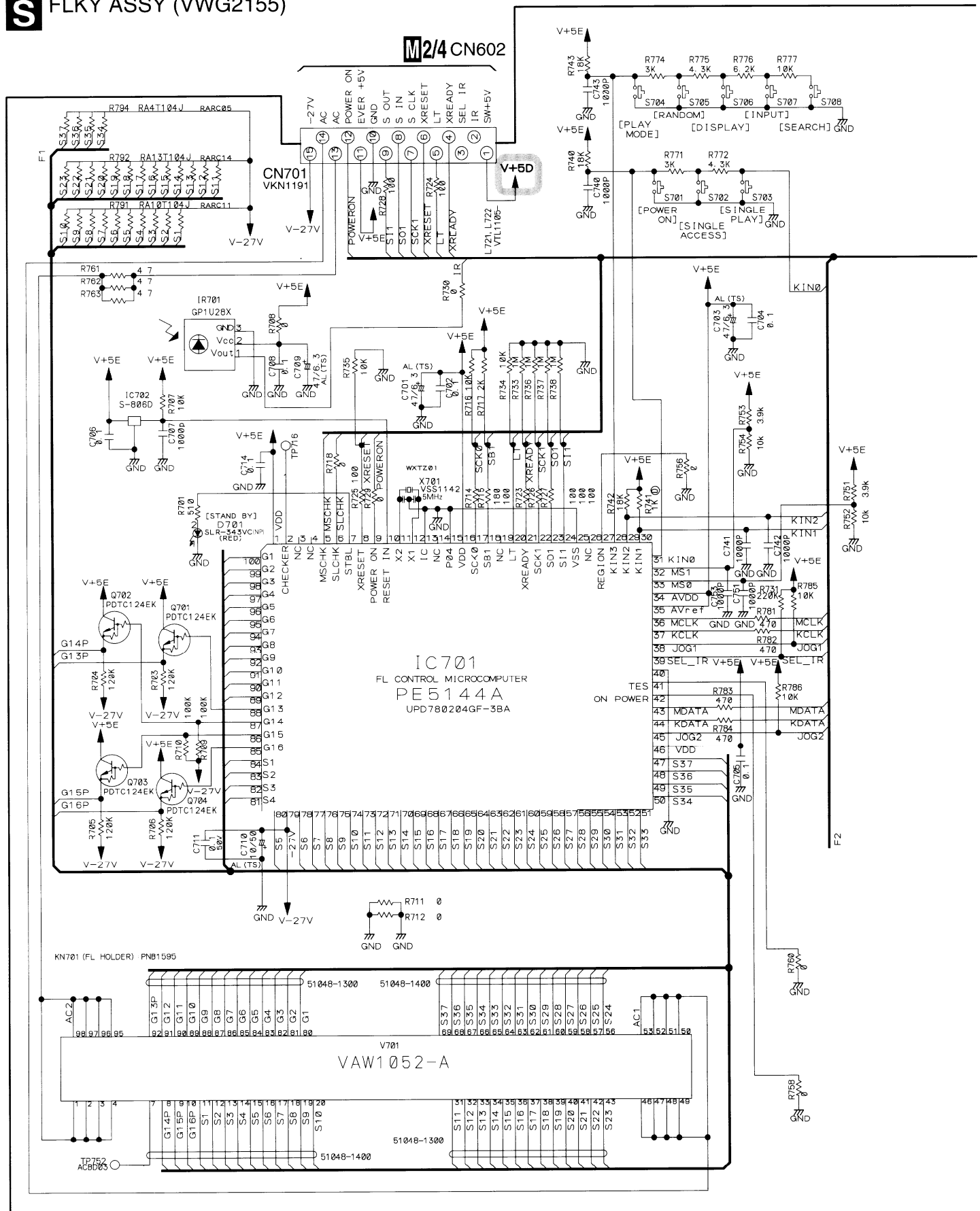

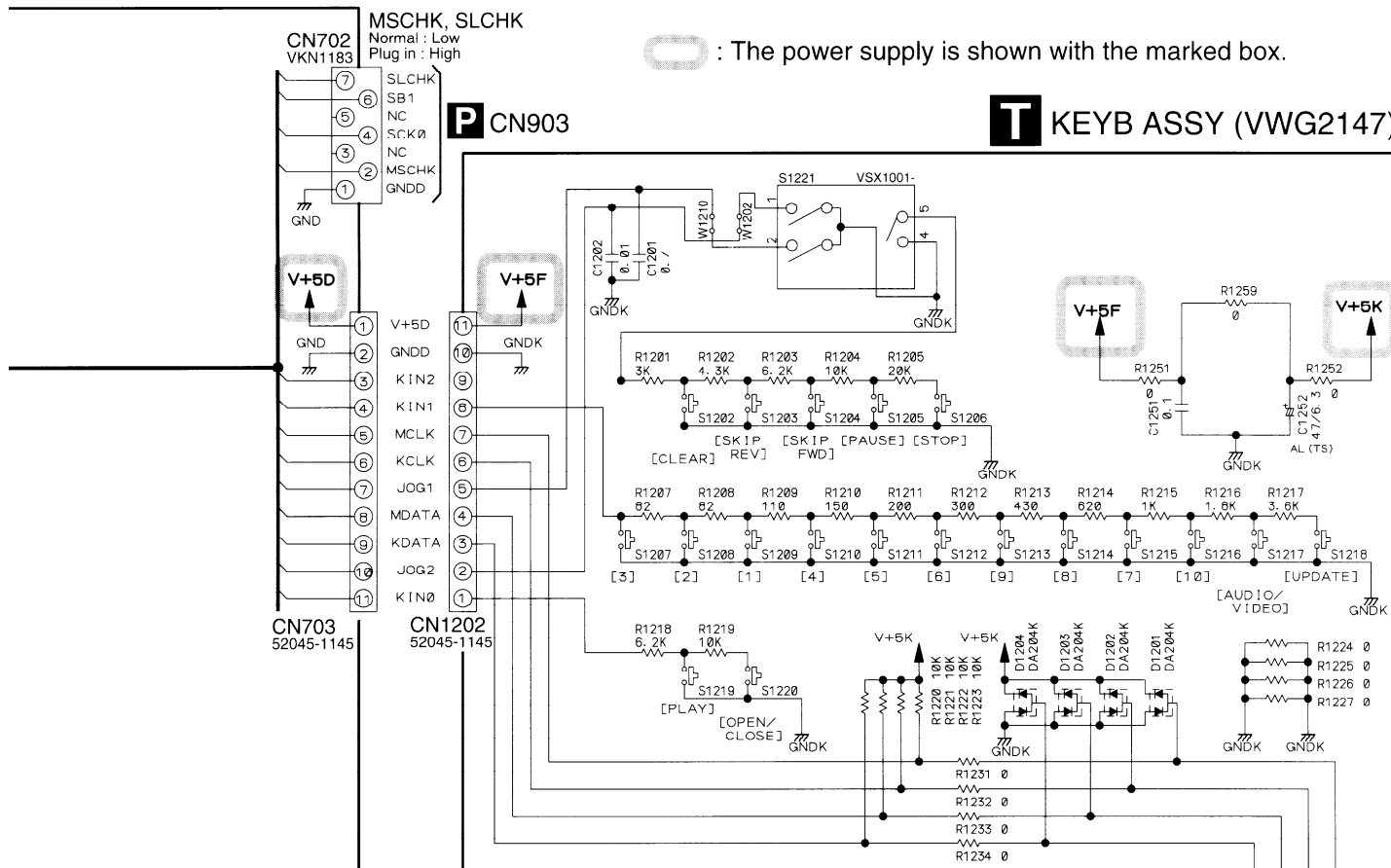

- FLKY ASSY**
 S701 : STYANDBY/ON
 S702 : ACCESS] SINGLE LOADER
 S703 : PLAY
 S704 : PLAYMODE
 S705 : RANDOM
 S706 : DISPLAY
 S707 : INPUT] TEXT
 S708 : SEARCH]

- KEYB ASSY**
 S1200 : DISC CHARA (MULTI JOG)
 S1201 : PUSH ENTER
 S1202 : CLEAR
 S1203 : ◀◀◀◀
 S1204 : ▶▶▶▶
 S1205 : || (PAUSE)
 S1206 : ■ (STOP)
 S1207 : 3
 S1208 : 2
 S1209 : 1
 S1210 : 4
 S1211 : 5
 S1212 : 6
 S1213 : 9
 S1214 : 8
 S1215 : 7
 S1216 : 10
 S1217 : AUDIO/VIDEO
 S1218 : UPDATE
 S1219 : ▶(PLAY)
 S1220 : ▲(OPEN/CLOSE)
- DIRECT CUSTOM

U PS2B ASSY (VWG2125)

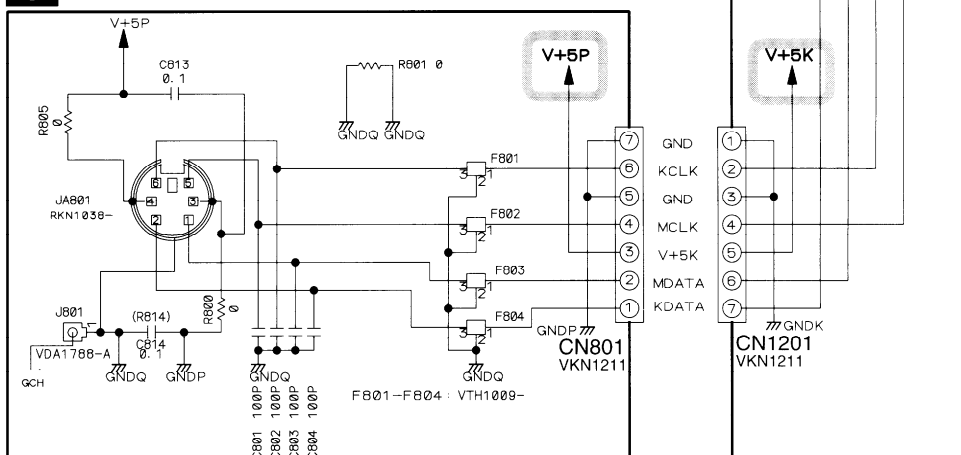

3.14 POWER SUPPLY ASSY

V POWER SUPPLY ASSY (VWR1317)

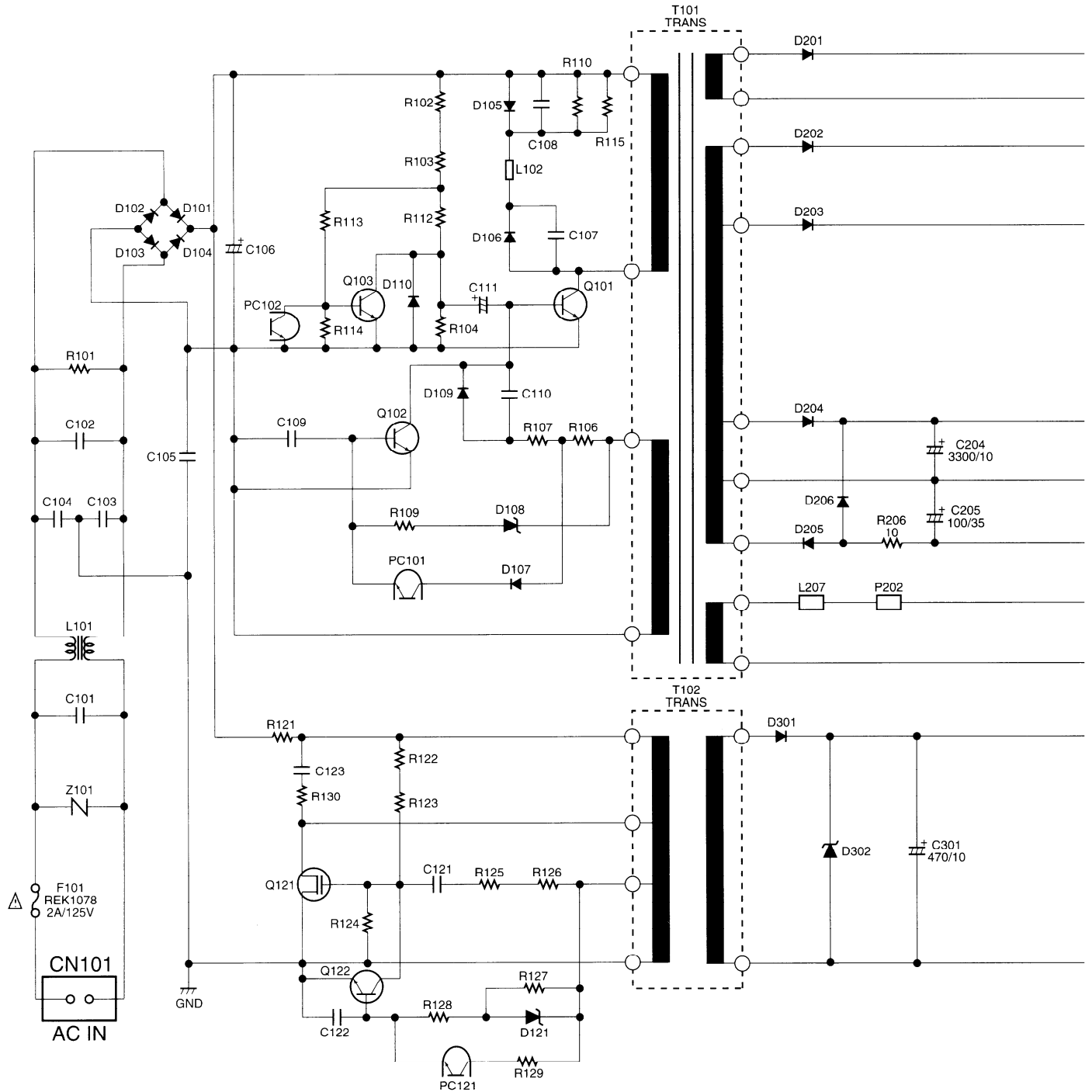

« NOTE OF SPARE PARTS IN POWER SUPPLY (SYPS) ASSY »

- In case of repairing, use the described parts only to prevent an accident.
- Please write the red ✓ mark on the board when the primary section of POWER SUPPLY (SYPS) Assy is repaired.
- Please take care to keep the space, not touching other parts when replacing the parts.

• NOTE FOR FUSE REPLACEMENT

CAUTION - FOR CONTINUED PROTECTION AGAINST RISK OF FIRE.
REPLACE WITH SAME TYPE AND RATINGS ONLY.

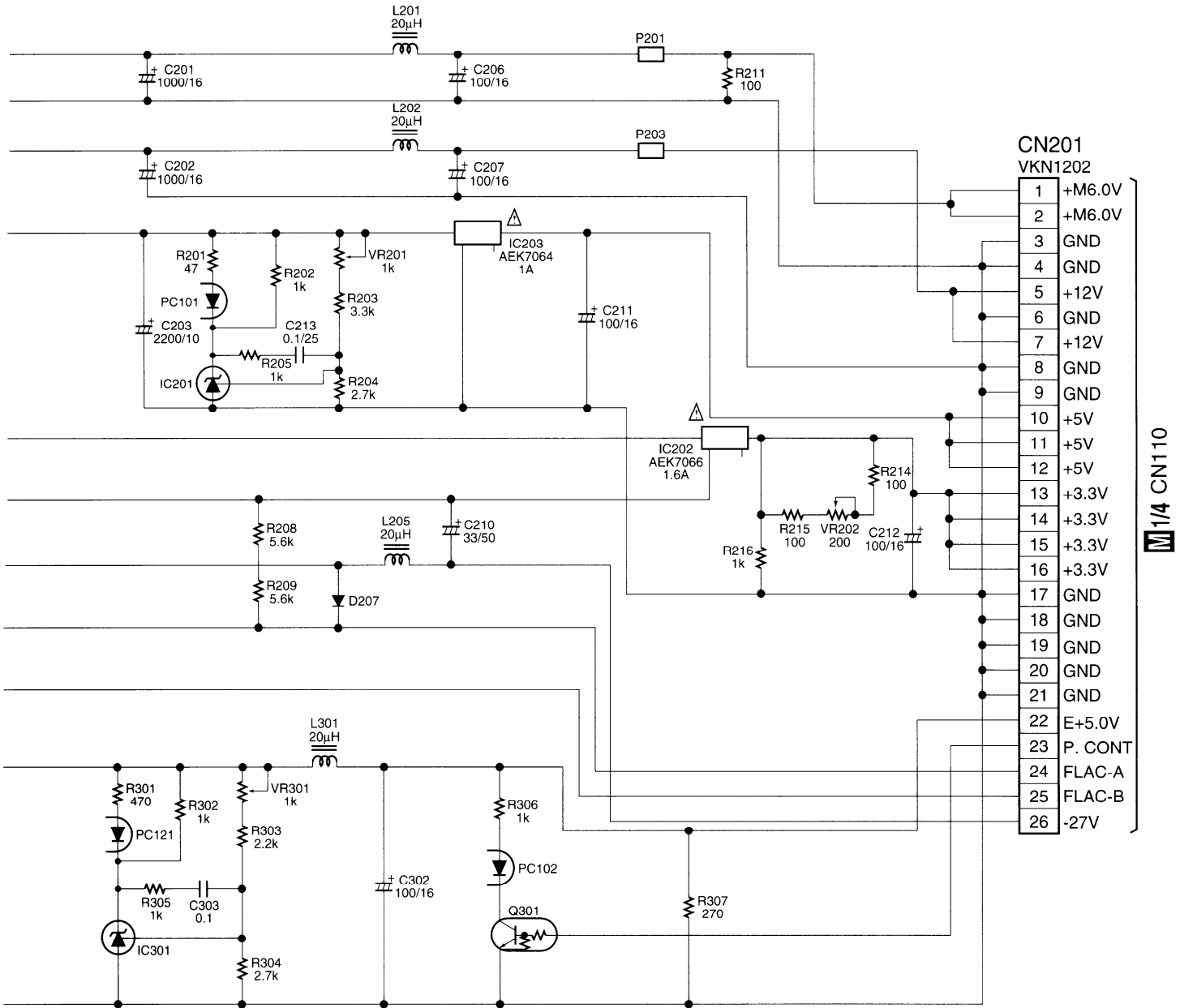

M 1/4 CN110

WAVEFORMS

Note : The encircled numbers denote measuring point in the schematic diagram.

Measurement condition : No. 1 to 4 and 6 to 11 : Disc MA1, Title 1-chp 1
 No. 5 : CD, ABEX-784 Track 1
 No. 12 to 14 : MJK1, Title 1-chp 4 or T2-1
 No. 15 to 17 : MJK1, Title 1-chp 5 or T2-19
 No. 18 to 20 : T2-19, Color-bar (WY and WV Types only)

● DVDM ASSY

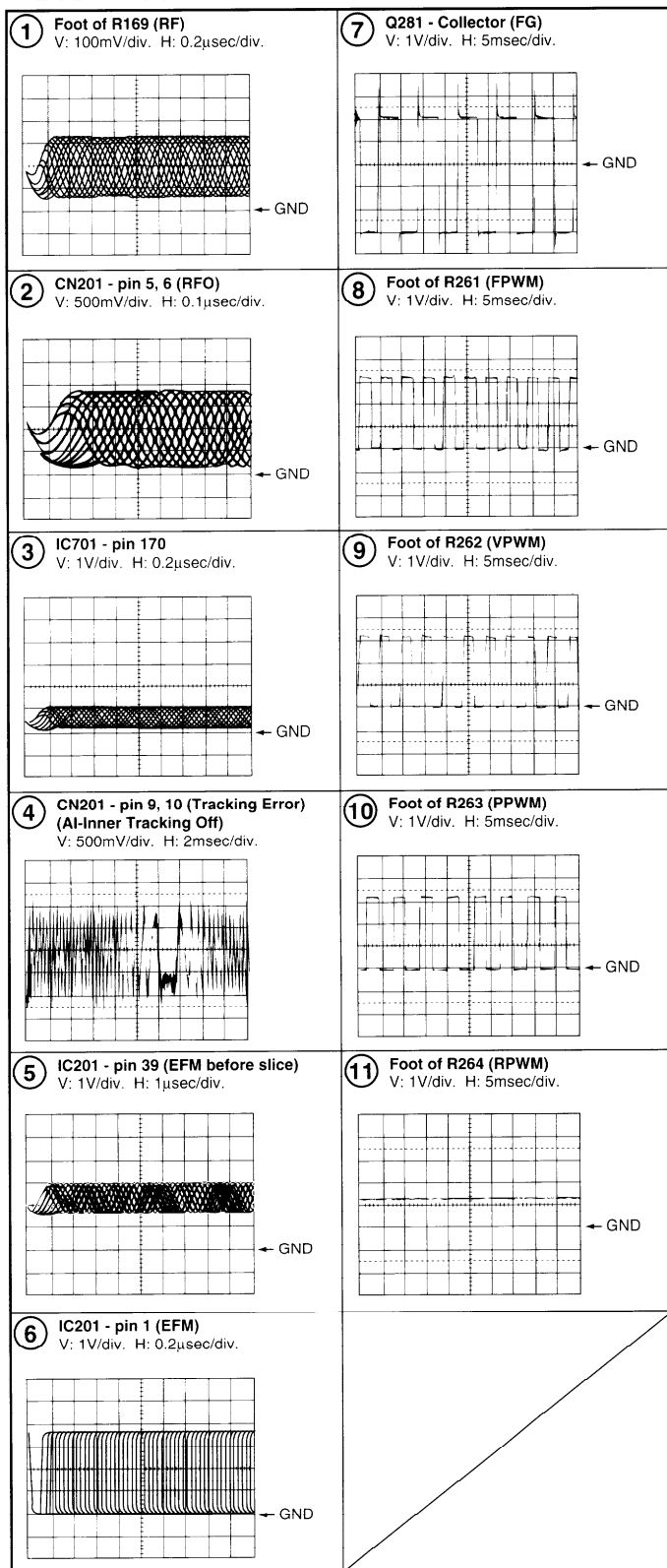



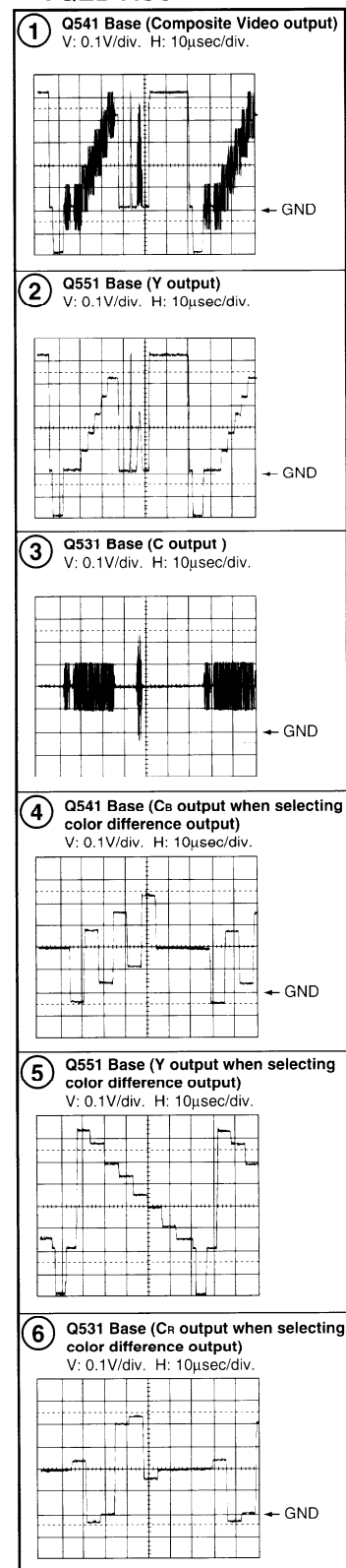



● VQEB ASSY

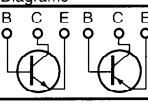

4. PCB CONNECTION DIAGRAM

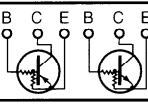
NOTE FOR PCB DIAGRAMS :

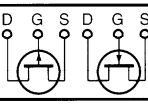
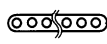
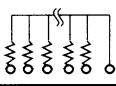
1. Part numbers in PCB diagrams match those in the schematic diagrams.
2. A comparison between the main parts of PCB and schematic diagrams is shown below.

Symbol In PCB Diagrams	Symbol In Schematic Diagrams	Part Name
		Transistor
		Transistor with resistor
		Field effect transistor
		Resistor array
		3-terminal regulator

3. The parts mounted on this PCB include all necessary parts for several destinations.
For further information for respective destinations, be sure to check with the schematic diagram.
4. View point of PCB diagrams.

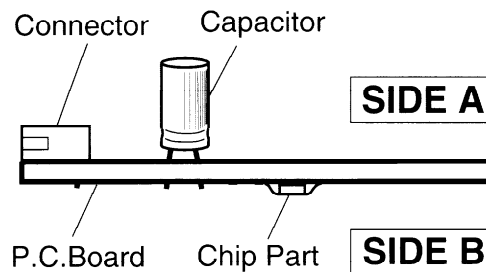

4.1 FGSB, SMEB, SSRB, SEMB, LOMB, LOSB, RADB, PHOB, DOMB, DOSB, VOLB and LEDB ASSYS

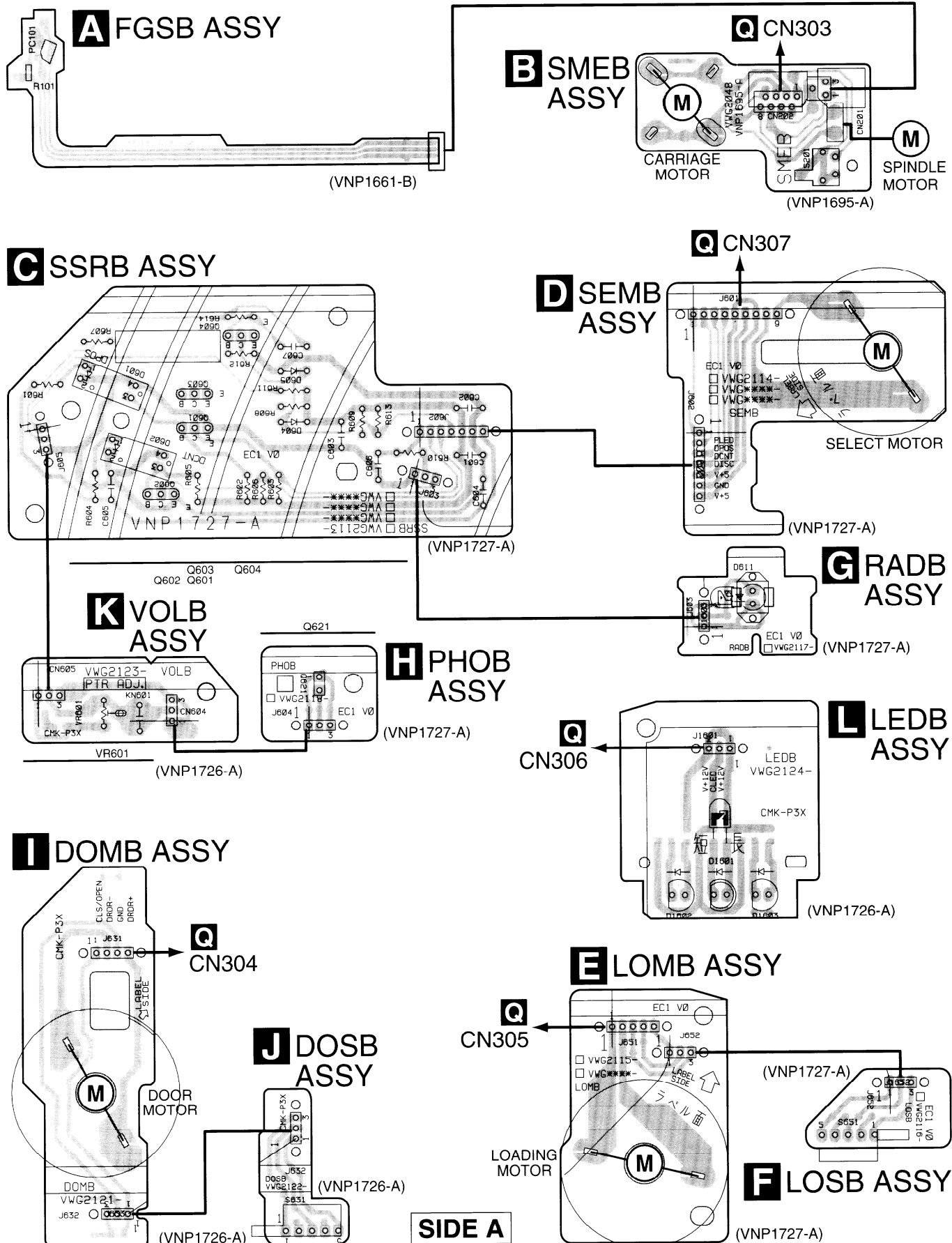

A B C D E F G H I J K L

5. PCB PARTS LIST

NOTES: ● Parts marked by "NSP" are generally unavailable because they are not in our Master Spare Parts List.

● The Δ mark found on some component parts indicates the importance of the safety factor of the part. Therefore, when replacing, be sure to use parts of identical designation.

● When ordering resistors, first convert resistance values into code form as shown in the following examples.

Ex.1 When there are 2 effective digits (any digit apart from 0), such as 560 ohm and 47k ohm (tolerance is shown by J=5%, and K=10%).

560 Ω → 56 × 10¹ → 561..... RD1/4PU 5 6 1 J

47k Ω → 47 × 10³ → 473..... RD1/4PU 4 7 3 J

0.5 Ω → R50 RN2H 5 0 K

1 Ω → IR0 RS1P 1 R 0 K

Ex.2 When there are 3 effective digits (such as in high precision metal film resistors).

5.62k Ω → 562 × 10¹ → 5621..... RN1/4PC 5 6 2 1 F

■ LIST OF WHOLE PCB ASSEMBLIES

Mark	Symbol and Description	Part No.
NSP	TRAVERSE MECHANISM ASSY	VWT1161
NSP	├ FGSB ASSY	VWG2009
NSP	├ SMEB ASSY	VWG2048
NSP	└ PICKUP ASSY	VWY1055
NSP	MECB ASSY	VWM1957
NSP	├ SSRB ASSY	VWG2113
NSP	├ SEMB ASSY	VWG2114
NSP	├ LOMB ASSY	VWG2115
NSP	├ LOSB ASSY	VWG2116
NSP	├ RADB ASSY	VWG2117
NSP	└ PHOB ASSY	VWG2118
NSP	SUBB ASSY	VWM1980
NSP	├ KEYB ASSY	VWG2147
NSP	├ DOMB ASSY	VWG2121
NSP	├ DOSB ASSY	VWG2122
NSP	├ VOLB ASSY	VWG2123
NSP	├ LEDB ASSY	VWG2124
	├ PS2B ASSY	VWG2125
	├ FLKY ASSY	VWG2155
	├ MDRB ASSY	VWG2127
	├ MSJB ASSY	VWG2178
	└ 232B ASSY	VWG2129
	DVDM ASSY	VWS1396
	VQEB ASSY	VWV1669
	AVJB ASSY	VWV1720
Δ	POWER SUPPLY ASSY	VWR1317

O AVJB ASSY

VWV1720 is constructed the same except for the following :

Mark	Symbol and Description	Part No.	Remarks
		VWV1720	
	IC201 IC241 F241 CHIP SOLID INDUCTOR C241, C243 R241, R242 R243-R245 R247-R249 CN503 DUAL 4P MINI DIN SOCKET JA201 4P PIN JACK JA504 2P PIN JACK JA505 3P PIN JACK	PE8001A PD0236AM VTF1096 CKSQYF104Z25 RS1/10S471J RS1/10S101J Not used AKP7023 VKB1133 VKB1135 VKB1152	

P MSJB ASSY

VWG2178 is constructed the same except for the following :

Mark	Symbol and Description	Part No.	Remarks
		VWG2149	
	JA901, JA903 1P PIN JACK	VKB1074	

S FLKY ASSY

VWG2155 is constructed the same except for the following :

Mark	Symbol and Description	Part No.	Remarks
		VWG2154	
	R753 R754	RS1/10S392J RS1/10S103J	

PCB PARTS LIST FOR DV-M301 UNLESS OTHERWISE NOTED

Mark	No.	Description	Part No.	Mark	No.	Description	Part No.
------	-----	-------------	----------	------	-----	-------------	----------

A FGSB ASSY

SEMICONDUCTOR

PC101 TLP910(O)

RESISTORS

All Resistors RS1/10S□□□J

B SMEB ASSY

SWITCH

S201 DSG1016

OTHERS

CN201 3P FFC CONNECTOR 52044-0345
CN202 8P FFC CONNECTOR VKN1212
PC BOARD SMEB VNP1695

C SSRB ASSY

SEMICONDUCTORS

Q604 2SC1740S
Q601,Q602 DTC124ES
D601,D602 GP1S58V

RESISTORS

All Resistors RD1/4PU□□□J

OTHERS

3P CABLE HOLDER 51048-0300
7P CABLE HOLDER 51048-0700
J603 JUMPER WIRE 3P D20PDD0310E
J602 JUMPER WIRE 7P D20PDD0725E
J605 JUMPER WIRE 3P D20PDY0310E

D SEMB ASSY

OTHERS

J601 7P CABLE HOLDER 51048-0700
9P CABLE HOLDER 51048-0900
JUMPER WIRE 9P D20PDY0930E

E LOMB ASSY

OTHERS

J652 3P CABLE HOLDER 51048-0300
5P CABLE HOLDER 51048-0500
J651 JUMPER WIRE 3P D20PDD0310E
JUMPER WIRE 5P D20PDY0530E

Mark	No.	Description	Part No.
F		LOS B ASSY	
		SWITCH	
		LEAF SWITCH	VSK1011
		OTHERS	
		3P CABLE HOLDER	51048-0300
G		RADB ASSY	
		SEMICONDUCTOR	
		D611	GL381J
		OTHERS	
		3P CABLE HOLDER LED HOLDER	51048-0300 RNK1795
H		PHOB ASSY	
		SEMICONDUCTOR	
		Q621	PT381FBC
		OTHERS	
		3P CABLE HOLDER JUMPER WIRE 3P	51048-0300 D20PDY0315E
I		DOMB ASSY	
		RESISTORS	
		All Resistors	RS1/10S□□□□
		OTHERS	
		3P CABLE HOLDER 4P CABLE HOLDER JUMPER WIRE 4P	51048-0300 51048-0400 D20PDY0445E
J		DOSB ASSY	
		SWITCH	
		S631 LEAF SWITCH	VSK1011
		OTHERS	
		3P CABLE HOLDER JUMPER WIRE 3P	51048-0300 D20PDD0315E
K		VOLB ASSY	
		RESISTOR	
		VR601 (22kΩ)	VCP1158
		OTHERS	
		CN604,CN605 3P JUMPER CONNECTOR	52147-0310
		KN601 JUMPER TERMINAL	PKX1001

Mark	No.	Description	Part No.
L		LEDB ASSY	
		SEMICONDUCTORS	
		D1611	HZU6.2B
		D1601	NSPB500-9235
		RESISTORS	
		All Resistors	RS1/10S□□□□
		OTHERS	
		J1601 3P CABLE HOLDER JUMPER WIRE 3P	51048-0300 D20PDY0325E
M		DVDM ASSY	
		SEMICONDUCTORS	
		IC21	CY2081SL-655
		IC101	LA9701M
		IC201	LC78652W
		IC609	LC89170M
		IC352	M56788FP
		IC801	M65773AFP
		IC802	MB811171622A
		IC612,IC904	MC74VHC541DT
		IC608,IC611,IC807,IC905	MC74VHCT541AD
		IC607	MC74VHCT574AD
		IC702	MN414800CSJ07
		IC261,IC302	NJM2100M
		IC601	PD3410A
		IC701	PD4995A
		IC604	TC55V1001AF8
		IC606	TC7SET32F
		IC751	TC7SH32FU
		IC24-IC27,IC303	TC7SHU04F
		IC610	TC7W53FU
		IC22	TC7WH74FU
		IC603	VYW1701
		Q106,Q109	2SA1576A
		Q105,Q114,Q251	2SC4081
		Q602	DTA114EUA
		Q107,Q111,Q601	DTC114EUA
		Q102	HN1A01F
		Q103,Q281,Q542,Q543	HN1B04FU
		Q101	HN1C01F
		Q112,Q113	HN1C01FU
		Q108	HN1K03FU
		Q503	RN1911
		D302	KV1470
		D601	RB501V-40
		D501,D502	RB521S-30
		COILS AND FILTERS	
		F5050,F5090 CHIP BEAD	DTF1067
		F4010,F4020,F4030,F4040,F4050	DTF1070
		CHIP BEAD	
		F4060,F8330,F9590 CHIP BEAD	DTF1070
		L304 CHIP COIL (1.5μH)	VTL1059
		L151 CHIP COIL (10μH)	VTL1061
		L47 CHIP BEAD	VTL1084
		L1400 CHIP BEAD	VTL1088
		L9490,L9500,L9510 CHIP BEAD	VTL1105
		L101,L330 CHIP COIL (8.2μH)	VTL1125

Mark No.	Description	Part No.
CAPACITORS		
C612		CCSRCH100D50
C123,C145,C21,C282,C617		CCSRCH101J50
C26		CCSRCH120J50
C126,C333		CCSRCH150J50
C206,C210,C211		CCSRCH151J50
C322		CCSRCH180J50
C116,C151,C314		CCSRCH220J50
C152		CCSRCH221J50
C632		CCSRCH330J50
C209		CCSRCH331J50
C104-C108,C128,C134,C297		CCSRCH470J50
C335		CCSRCH470J50
C122,C208		CCSRCH471J50
C127,C334		CCSRCH5R0C50
C124,C146		CCSRCH680J50
C117,C240,C352,C360		CCSRCH681J25
C129,C142,C22,C405,C601		CEV101M10
C701,C763,C801,C802,C804		CEV101M10
C113,C139,C358,C368,C411		CEV220M16
C111,C147,C149,C205,C207		CEV470M6R3
C401,C403,C407		CEV470M6R3
C502		CKSQYB103K50
C140,C223,C224,C252,C264		CKSQYB105K10
C312		CKSQYB105K10
C229		CKSQYB224K16
C217		CKSQYF105Z16
C216,C313		CKSRYB102K50
C133,C136,C203,C220,C225		CKSRYB103K50
C239,C320,C321,C619,C703		CKSRYB103K50
C722		CKSRYB103K50
C101,C102,C114,C118,C119		CKSRYB104K16
C121,C130,C138,C204		CKSRYB104K16
C212,C213,C227,C228,C231		CKSRYB104K16
C24,C263,C315-C317,C332		CKSRYB104K16
C281,C354		CKSRYB222K50
C153,C266		CKSRYB223K25
C214,C251,C261		CKSRYB472K50
C357		CKSRYB473K16
C330		CKSRYB682K50
C109,C110,C120,C131,C148		CKSRYF104Z16
C150,C202,C215,C221,C222		CKSRYF104Z16
C226,C230,C235,C265,C29		CKSRYF104Z16
C31,C33,C35,C359,C367		CKSRYF104Z16
C369-C372,C402,C404,C406		CKSRYF104Z16
C408,C410,C412,C501		CKSRYF104Z16
C602-C611,C613-C616,C618		CKSRYF104Z16
C621-C631,C702,C704-C714		CKSRYF104Z16
C716-C721,C723-C725		CKSRYF104Z16
C761,C762,C822,C827,C829		CKSRYF104Z16
C832,C833,C836,C920,C921		CKSRYF104Z16
C143,C319,C806-C819		CKSRYF105Z10
C328,C821,C824,C825,C828		VCG1030
(2.2μF)		
C830,C837 (2.2μF)		VCG1030
C23,C299 (0.47μF)		VCG1032
VC21 (30pF)		VCM1013

Mark No.	Description	Part No.
RESISTORS		
R123 (39Ω×4)		ACN7047
R715,R716 (47Ω×4)		ACN7077
R531,R543,R545,R613 (10kΩ×4)		DCN1094
R648,R649,R706,R707,R748		DCN1094
(10kΩ×4)		
R751 (10kΩ×4)		DCN1094
R121,R532,R689,R691,R732		DCN1104
(22Ω×4)		
R736,R785,R786,R818-R820		DCN1104
(22Ω×4)		
R825,R848,R849 (22Ω×4)		DCN1104
R1020,R162,R2010,R2020,R2030		RS1/10S0R0J
R2040,R3050,R3520,R506,R510		RS1/10S0R0J
R520,R601,R701,R801,R8410		RS1/10S0R0J
R9200,R9210,R9230,R9240		RS1/10S0R0J
R939-R948,R952-R958,R960		RS1/10S0R0J
R964,R973-R975,R979		RS1/10S0R0J
R361,R364		RS1/16S1203F
R363,R365		RS1/16S1503F
R164		RS1/16S5600F
R3510 (100Ω)		VCN1120
Other Resistors		RS1/16S□□□□

OTHERS

X601	CHIP CERAMIC	DSS1110
	(20MHz)	
	FLEXIBLE CABLE 7P	VDA1681
CN201	B TO B CONNECTOR 14P	VKN1324
CN120	24P FFC CONNECTOR	VKN1464
CN1030,CN921	12P FFC CONNECTOR	VKN1471
CN905	14P FFC CONNECTOR	VKN1473
CN602,CN901	15P FFC CONNECTOR	VKN1474
CN110	26P FFC CONNECTOR	VKN1479
CN903	11P FFC CONNECTOR	VKN1497
CN802		VKN1529
CN107	B TO B CONNECTOR 40P	VKN1575
	7P FFC CONNECTOR	
X21	BARCODE LABEL	VRW1773
	CRYSTAL RESONATOR	VSS1129
	(13.824MHz)	

N VQEB ASSY

SEMICONDUCTORS

IC102		MB811171622A
IC101		PM0023AF
IC105,IC106		TC7SH14FU
Q531,Q532,Q541,Q542		2PB709A
Q551,Q552		2PB709A

COIL AND FILTER

F102	VIDEO FILTER	VTF1155
L101	CHIP COIL	VTL1067

Mark	No.	Description	Part No.
CAPACITORS			
	C130		CCSRCH102J50
	C101,C120		CEV101M16
	C110-C119,C121-C126,C150		CKSRYB104K16
	C160,C532,C542,C552		CKSRYB104K16
	C201,C202 (2.2μF)		VCG1031
RESISTORS			
	R105,R106,R404,R405 (22Ω×4)		DCN1104
	R12,R201,R409,R418,R419		RS1/10S0R0J
	R501		RS1/10S0R0J
	R122		RS1/10S2701F
	R532,R542,R552		RS1/16S3300F
	R534,R544,R554		RS1/16S4700F
	Other Resistors		RS1/16S□□□J
OTHERS			
	CN101	B TO B CONNECTOR 40P	VKN1530

AVJB ASSY

SEMICONDUCTORS

	IC203		BA4560F
	IC502		BU4551BF
	IC501		LA7135AM
△	IC206		NJM78L05A
△	IC150		NJM78M08FA
	IC201		PCM1716E
	IC202		TC7SU04F
	Q202,Q581-Q584		2PB709A
	Q151,Q281,Q585		2PD601A
	Q150		2SB1260
	Q120		2SC1740S
	Q257,Q277		2SD2114K
	Q201,Q561,Q586-Q589		PDTC124EK
	D230		HZU5.6B
	D281		MA111

COILS AND FILTER

L220	CHIP INPEDER	DTL1028
L202		LAU1ROJ-TA
F201	CHIP SOLID INDUCTOR	VTF1096

SWITCH AND RELAY

S501		VSH1009
RY281		RSR1029

CAPACITORS

C253,C273		CCSQCH221J50
C251,C271		CCSQCH330J50
C523-C525		CCSQCH470J50
C255,C275		CCSQSL331J50
C104,C154,C211,C232,C501		CEAT101M10
C526,C528,C581,C582		CEAT101M10
C102,C121,C122,C152,C231		CEAT101M16
C203,C541,C555,C560		CEAT102M6R3
C206,C207		CEAT470M16
C250,C252,C270,C272		CEAT470M25

Mark	No.	Description	Part No.
	C550,C552		CEAT471M6R3
	C150		CKSQYB103K50
	C520-C522,C561,C585		CKSQYB104K25
	C587		CKSQYB222K50
	C583		CKSQYB473K50
	C101,C103,C120,C123,C151		CKSQYF104Z25
	C153,C204,C205,C208,C209		CKSQYF104Z25
	C214,C215,C230,C233,C234		CKSQYF104Z25
	C281,C290,C502,C527		CKSQYF104Z25
	C529,C530,C590		CKSQYF104Z25
	C201,C202,C210,C212,C213		CKSQYF105Z16
	C531		CKSQYF105Z16

RESISTORS

R597-R599		RN1/10SC18R0D
R533,R534,R542,R551,R555		RN1/10SC62R0D
R558,R581,R585,R589		RN1/10SC62R0D
R250,R270		RN1/10SE1602D
R251,R271		RN1/10SE2702D

Other Resistors RS1/10S□□□J

OTHERS

CN503	DUAL 4P MINI DIN SOCKET	AKP7020
JA505	3P PIN JACK	VKB1131
JA201	4P PIN JACK	VKB1132
JA504	2P PIN JACK	VKB1134
CN502	7P FFC CONNECTOR	VKN1183
CN101	14P FFC CONNECTOR	VKN1190
CN501	15P FFC CONNECTOR	VKN1191
	SCREW TERMINAL	VNE1948

MSJB ASSY

SEMICONDUCTORS

IC922		TC74HC00AF
IC901,IC931		TC74HCU04AF

COILS AND FILTERS

L901	PULSE TRANS.	PTL1003
L902	NOISE FILTER	RTF1167
F901,F904,F912,F922		VTF1096
	CHIP SOLID INDUCTOR	

CAPACITORS

C932		CCSQCH101J50
C902,C912,C915,C958		CEAT101M10
C903,C931		CKSQYF103Z50
C905,C906,C913,C916,C922		CKSQYF104Z25
C933,C936,C959		CKSQYF104Z25

RESISTORS

All Resistors RS1/10S□□□J

OTHERS

CN904,CN905	MINI JACK	AKN1028
JA902	OPTICAL LINK OUT	GP1F32T
J990	HOUSING ASSY	VKP2244

Mark	No.	Description	Part No.
	JA901,JA903	1P PIN JACK	VKB1074
	CN902,CN903		VKN1211
	CN901	7P FFC CONNECTOR	VKN1215
		11P FFC CONNECTOR	VNE1948
		SCREW TERMINAL	

Q MDRB ASSY

SEMICONDUCTORS

IC301	LA6531
Q303	2SA1037K
Q301	2SC2412K
Q302	PDTC124EK

CAPACITORS

C306	CCSQCH101J50
C303	CEAT101M10
C301	CEAT470M16
C302,C304,C305,C307	CKSQYF104Z25

RESISTORS

R333	RS1/10S1503F
R302,R329	RS1/10S1803F
R311,R312	RS1/10S2202F
R335,R336	RS1/10S3003F
R322,R323,R326,R327	RS1/10S3302F

R324,R328	RS1/10S3902F
R334,R338	RS1/10S3903F
Other Resistors	RS1/10S□□□□

OTHERS

CN306	3P JUMPER CONNECTOR	52147-0310
CN304	4P JUMPER CONNECTOR	52147-0410
CN305	5P JUMPER CONNECTOR	52147-0510
CN307	9P JUMPER CONNECTOR	52147-0910
CN303	8P FFC CONNECTOR	VKN1184

CN301,CN302	12P FFC CONNECTOR	VKN1188
-------------	-------------------	---------

R 232B ASSY

SEMICONDUCTOR

IC401	MAX232EPE
-------	-----------

FILTERS

F401-F403	EMI FILTER	VTH1009
-----------	------------	---------

CAPACITORS

C404,C405	CEANP1R0M50
C401	CEAT101M10
C403	CEAT1R0M50
C402	CKSQYF104Z25
C406	CEAL1R0M50

RESISTORS

All Resistors	RS1/10S□□□□
---------------	-------------

OTHERS

JA401	15P D-SUB SOCKET	DKN1111
CN401	7P FFC CONNECTOR	VKN1183

Mark	No.	Description	Part No.
S		FLKY ASSY	
		SEMICONDUCTORS	
	IC701		PE5144A
	IC702		S-806D
	Q701-Q704		PDTC124EK
	D701		SLR-343VC(NP)

SWITCHES

S701-S708	ASG7013
-----------	---------

CAPACITORS

C710	CEAL100M50
C701,C703,C709	CEAL470M6R3
C740-C743,C751,C753	CKSQYB102K50
C707	CKSQYF102Z50
C702,C704-C706,C708,C714	CKSQYF104Z25
C711	CKSQYF104Z50

RESISTORS

R791	RA10T104J
R792	RA13T104J
R794	RA4T104J
R741	RN1/10SE1001D
Other Resistors	RS1/10S□□□□

OTHERS

	13P CABLE HOLDER	51048-1300
CN703	11P FFC CONNECTOR	52045-1145
IR701	REMOTE RECEIVER UNIT	GP1U28X
V701	FL TUBE	VAW1052
CN702	7P FFC CONNECTOR	VKN1183

CN701	15P FFC CONNECTOR	VKN1191
X701	CERAMIC RESONATOR (5MHz)	VSS1142

T KEYB ASSY

SEMICONDUCTORS

D1201-D1204	DA204K
-------------	--------

SWITCHES

S1202-S1220	ASG7013
S1221	VSX1001

CAPACITORS

C1252	CEAL470M6R3
C1201,C1202	CKSQYF103Z50
C1203,C1251	CKSQYF104Z25

RESISTORS

All Resistors	RS1/10S□□□□
---------------	-------------

OTHERS

CN1202	11P FFC CONNECTOR	52045-1145
CN1201	7P FFC CONNECTOR	VKN1211

Mark	No.	Description	Part No.
------	-----	-------------	----------

U PS2B ASSY

FILTERS

F801-F804	EMI FILTER	VTH1009
-----------	------------	---------

CAPACITORS

C801-C804		CCSQCH101J50
C813,C814		CKSQYF104Z25

RESISTORS

All Resistors		RS1/10S□□□□
---------------	--	-------------

OTHERS

JA801	MINI DIN 6P SOCKET	RKN1038
CN801	7P FFC CONNECTOR	VKN1211

V POWER SUPPLY ASSY

SEMICONDUCTORS

△	IC203 (1A)	AEK7064
△	IC201,IC202 (1.6A)	AEK7066
	VARISTOR	VZF1092

OTHERS

△	FU101	FUSE (2A)	REK1078
	CN201	26P FFC CONNECTOR	VKN1202

6. ADJUSTMENT

6.1 ADJUSTMENT ITEMS AND LOCATION

Note : When the Traverse mechanism adjustment is not properly adjusted, jitter, error rate and play ability are defective.
The noise may come out by the case.

■ Adjustment Points (PCB Part)

DVDM ASSY

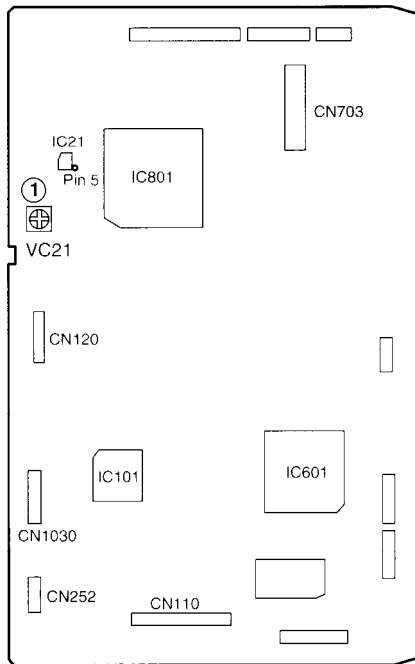

SIDE A

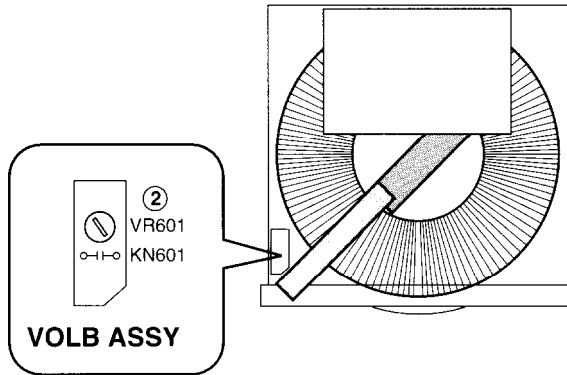

■ Adjustment Items

[Electrical Part]

- ① Master Clock Adjustment
- ② Disc-select Rotation Adjustment

6.2 JIGS AND MEASURING INSTRUMENTS

<p>CD TEST DISC (YEDS-18)</p>	<p>Digital multi meter</p>	<p>Frequency counter Display digit ≥ 8-digit</p>	<p>DC power supply</p>	<p>Oscilloscope</p>
<p>⊖ Screwdriver (small)</p>	<p>⊖ Precise screwdriver</p>	<p>Test mode remote control unit (GGF1067)</p>	<p>Jig (Peak hold circuit)</p>	

6.3 NECESSARY ADJUSTMENT POINTS

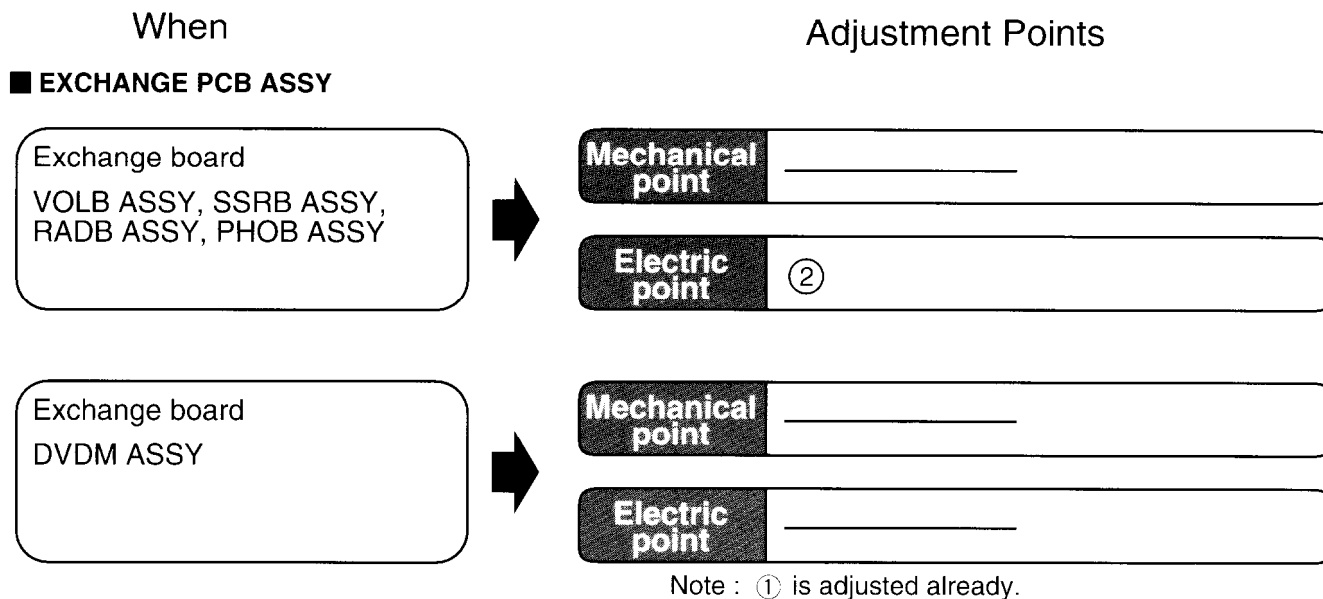

6.4 ELECTRICAL ADJUSTMENT

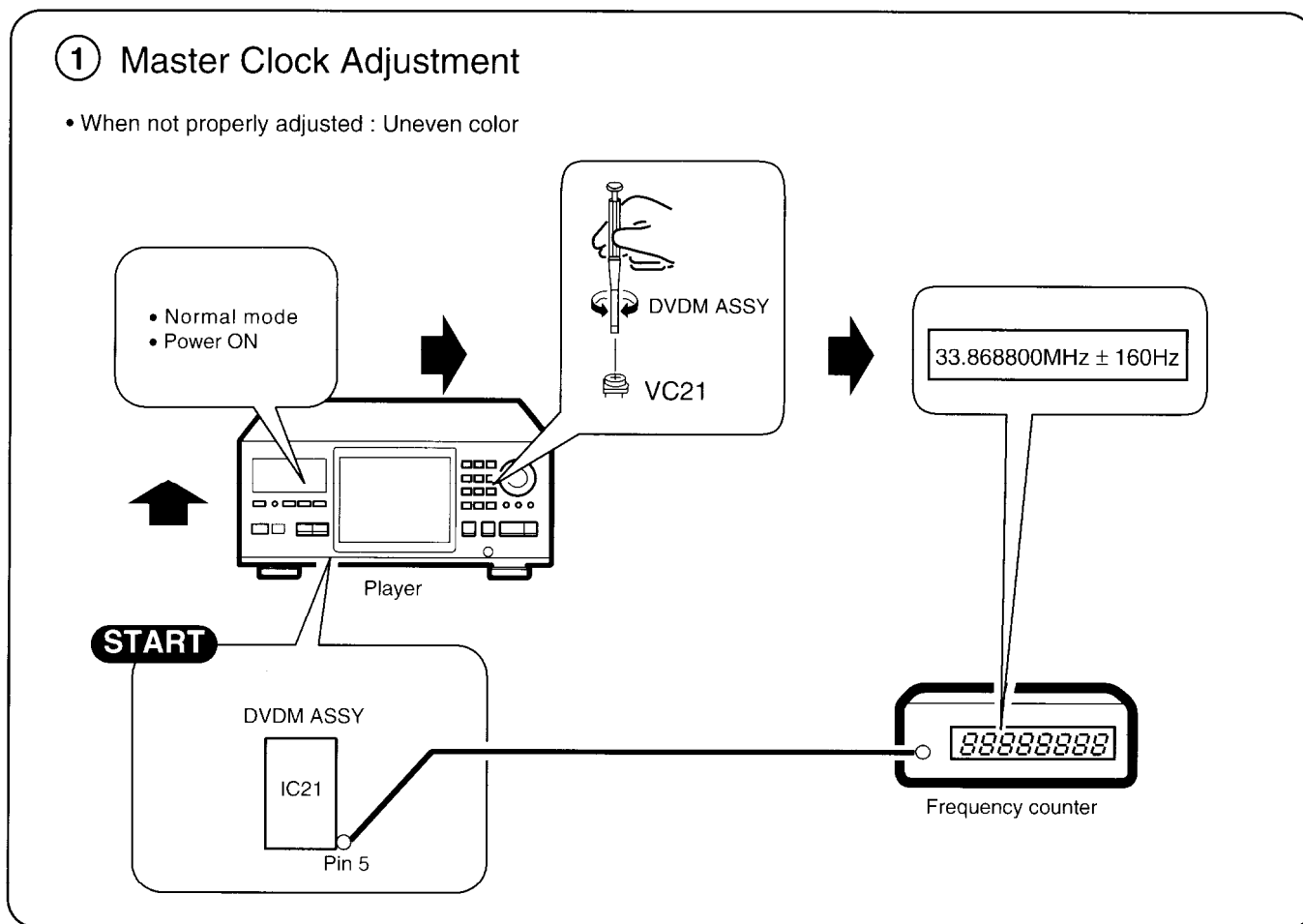

② Disc-select Rotation Adjustment

● Connection Diagram for Adjustment

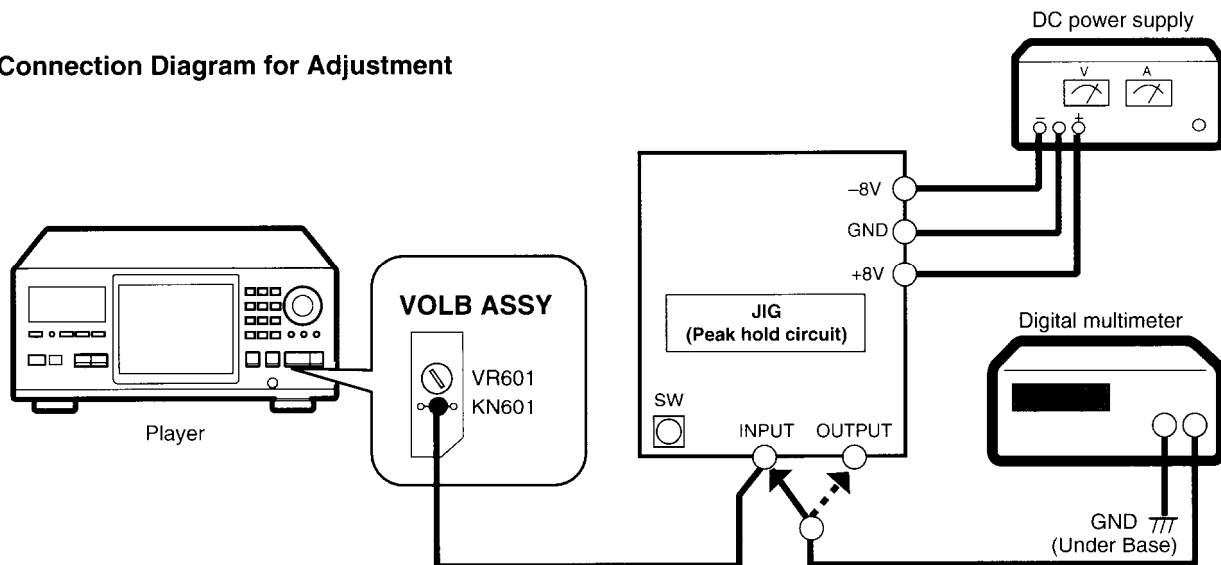

● Adjustment Procedure

1. Connect all equipment as shown in the diagram.
2. Turn on the power (Normal mode) and put the test disc in the No. 1 disc slot.
3. Enter the Test mode by pressing the "ESC" → "TEST" button of the test mode remote control unit.
4. Press the "DIG/ANA" button of the test mode remote control unit. (Disc 1 is clamped.)
5. Adjust VR601 on the VOLB Assy so that the voltage becomes $830 \pm 5\text{mV}$.
6. Switch the connection of Digital multimeter from INPUT to OUTPUT of the Jig.
7. Press the "DIG/ANA" button of the test mode remote control unit. (Starts the disc detection and peak hold .)
8. Confirm the voltage during the disc detection.
If voltage is between 920 to 1170mV, go to step 13. If not, go to step 9.
9. Switch the connection of Digital multimeter form OUTPUT to INPUT of the Jig.
10. Press the "DIG/ANA" button of the test mode remote control unit. (Disc 1 is clamped.)
11. Adjust VR601 to become the value for addition (or subtraction) that to have an adjustment voltage.
(Refer to the following table.)
12. Perform steps 6 to 8 again and confirm the voltage during the disc detection.
If voltage is between 920 to 1170mV, go to step 13. If not, repeat steps 9 to 12.
13. Confirm that Disc No. display doesn't become "1" others when you turn the Jog dial.
14. Release the Test mode by pressing the "ESC" button or turn off the power.

Adjustment voltage value

Peak hold voltage (mV)	Adjustment voltage (mV)
to 859	+20
859 to 879	+10
879 to 920	+ 5
920 to 1170	OK
1170 to 1309	- 5
1309 to 1520	-10
1520 to 1840	-20
1840 to 2220	-30
2220 to	-40

● Simple Adjustment of Disc Detection

● Connection Diagram for Adjustment

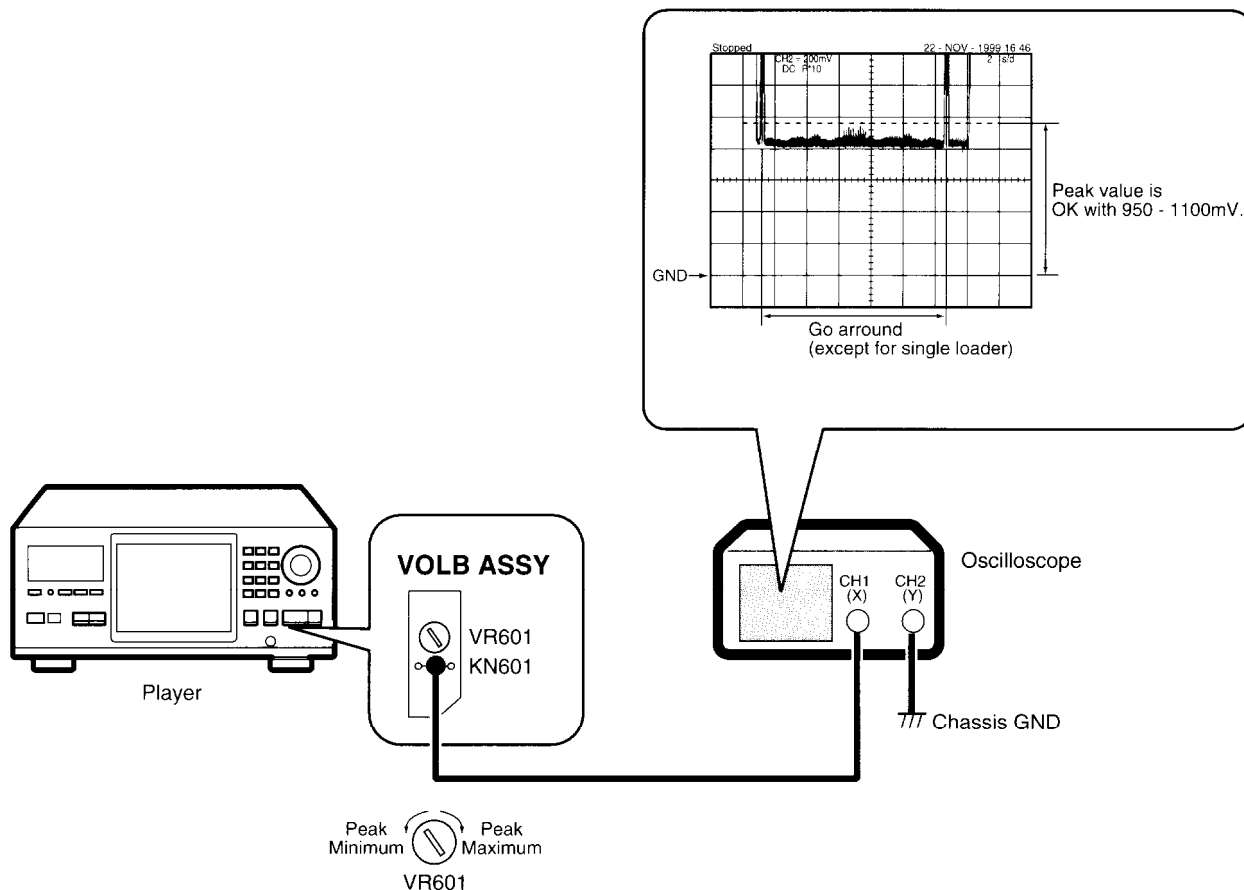

● Adjustment Procedure

1. Connect an oscilloscope.
2. Turn the POWER SW to ON.
3. Open the Food.
4. Press the "SINGLE LOADER PLAY" button of the player without putting a disc.
Start the disc detection if loading is come and there is no disc.
5. If the peak value is 950 - 1100mV while a disc detection goes around the disc, is OK.
6. When peak value is except for OK range, adjust VR601 and repeat steps 3 - 5.

7. GENERAL INFORMATION

7.1 DIAGNOSIS

7.1.1 TEST MODE SCREEN DISPLAY

Consecutive double-OSD display is supported during test mode. The screen is composed 10 lines with a maximum of 32 characters per line. It can't be used with the debugging display mode together.

• Screen Composition

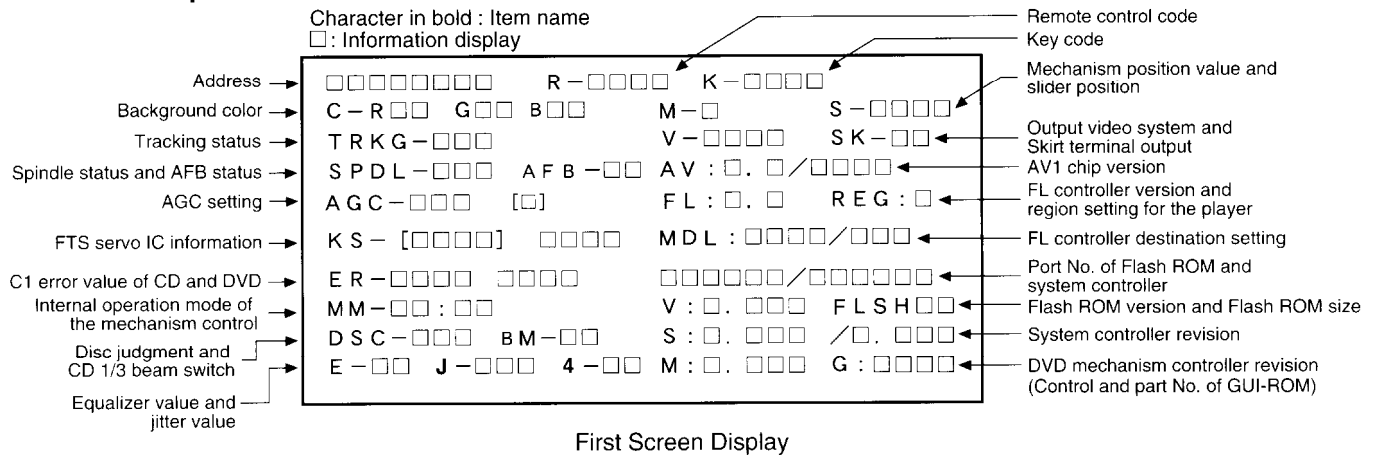

Caution :

The first screen and second screen switch by pressing [DISPLAY] key of the remote control unit.
It is only a version display part on the lower right of the screen those contents of display change.
ATB : ON/OFF information display and AGC manual setting display deleted with the second generation.
The displays of Tilt error value, Tilt servo status and pickup DVD/CLD display deleted with the third generation becomes LD part is deleted.

• Description of Each Item on the Display

(1) Address indication

The address being traced is displayed in number.
DVD : ID indication (hexadecimal number, 8 digits)
[* * * * * * * *]
CD : A-TIME (min. sec.) [0 0 0 0 * * * *]
(Note : For DVDs, decimal-number indication is possible.)

(2) Code indication of the remote control unit

[R - * * * *]
The code for the key pressed on the remote control unit, which is received by the FL controller, is displayed while the key is pressed. In the case of the double code, the second code will be displayed.

(3) Key code indication for the main unit [K - * * *]

The code for the key pressed on the main unit, which is received by the system controller, is displayed while the key is pressed.
At keyboard code input
K-KBD * * * * :
At mouse code input
K-MS * * * *

(4) Background color indication [C - R * * G * * B * *]

(5) Tracking status [TRKG - * * *]

Tracking on [ON]
Tracking off [OFF]

(6) ① Spindle status [SPDL - * * *]

Spindle accelerator and brake, free-running [A/B]
FG servo [FG]
Rough, velocity phase servo [SRV]
Offset addition, rough, velocity phase servo [O_S]

② AFB status [AFB - * *]

ON [ON]
OFF [OFF]

(7) Mechanism position value [M - *]

Position code [1] to [3]

(8) Slider position [S - * * * *]

CD TOC area [IN]
CD active area [CD]

(9) AGC setting [AGC - * *]

AGC on [AGC-ON]
AGC off [AGC-OFF]

(10) Output video system [V - * * * *]

NTSC system	[NTSC]
PAL system	[PAL]
Auto-setting	[AUTO]

Skirt terminal output [SK - * *]

VIDEO	[00]
S-VIDEO	[01]
RGB	[02]

* : Display only the model which can do the output setting of skirt terminal.

(11) FTS servo IC information

DSP coefficient indication [KS - [* * * *] * * * *]

Displays the address (four digits) of the specified coefficient and the setting value (four digits) with [TEST] and [9] keys.

(12) Error rate indication

- ① C1 error value of CD [ER - C1 * * * *]
 ② C1 error value of DVD [ER - * * * * * * * *]

(13) Internal operation mode of mechanism controller

[MM - * * : * *]

Internal mechanism mode (2 digits) and internal mechanism step (2 digits) of the mechanism controller

(14) ① Disk sensing [DSC - * * *]

The type of discs loaded is displayed.
 [DVD], [CD], [VCD], []

② CD 1/3 beam switch [BM - * *]**(15) ① Equalizer value [E - * *]****② Jitter value [J - * *]**

nake the jitter four times, and renew it in every one second.
 [4 - * *]
 CD is effective only in the jitter value.

(16) Version of the AV-1 chip [AV : * . * / * * * *]**(17) ① Version of the FL controller**

[FL : * * * *]

② Region setting of the player [REG : *]

Setting value [1] to [6]

(18) Destination setting of the FL controller

[MDL : * * * * / * * * *]

For characters in front represent the type of model :

There characters that follow represent the destination code.

J : /J, K : /KU, /KC, /KU/KC, R : /RAM, /RL, /RD, /LB,

WY : /WY

(19) The part number of the flash ROM and system controller [* * * * * / * * * * * * * *]

- ① Part number of the flash ROM <Front>
 (Example) VYW1536-A → W1536A
 (Example) PD6256A9 → 6256A9
 ② Part number of the system controller <Rear>
 (Example) PD3381T1 → 3381T1

(20) ① Version of the flash ROM [V : * . * * *]**② Flash ROM size [FLSH **]****(21) Revision of the system controller**

[S : * . * * * / * . * * *]

- ① Revision number of the external ROM part (flash ROM) of the system controller <Front>
 ② Revision of the internal ROM part of the system controller <Rear>

(22) Revision of the DVD mechanism controller

[M : * . * * *]

Revision number of the external ROM part (flash ROM) of the DVD mechanism controller

(23) Control and part numbers of the GUI-ROM

[G : * * * *]

No GUI model displays as "— / —".

OEM model displays the part number of GUI-ROM [G : * * * *]

7.1.2 TROUBLE SHOOTING

- No Power ON
- FL is not turned ON
- FL indication is unusual

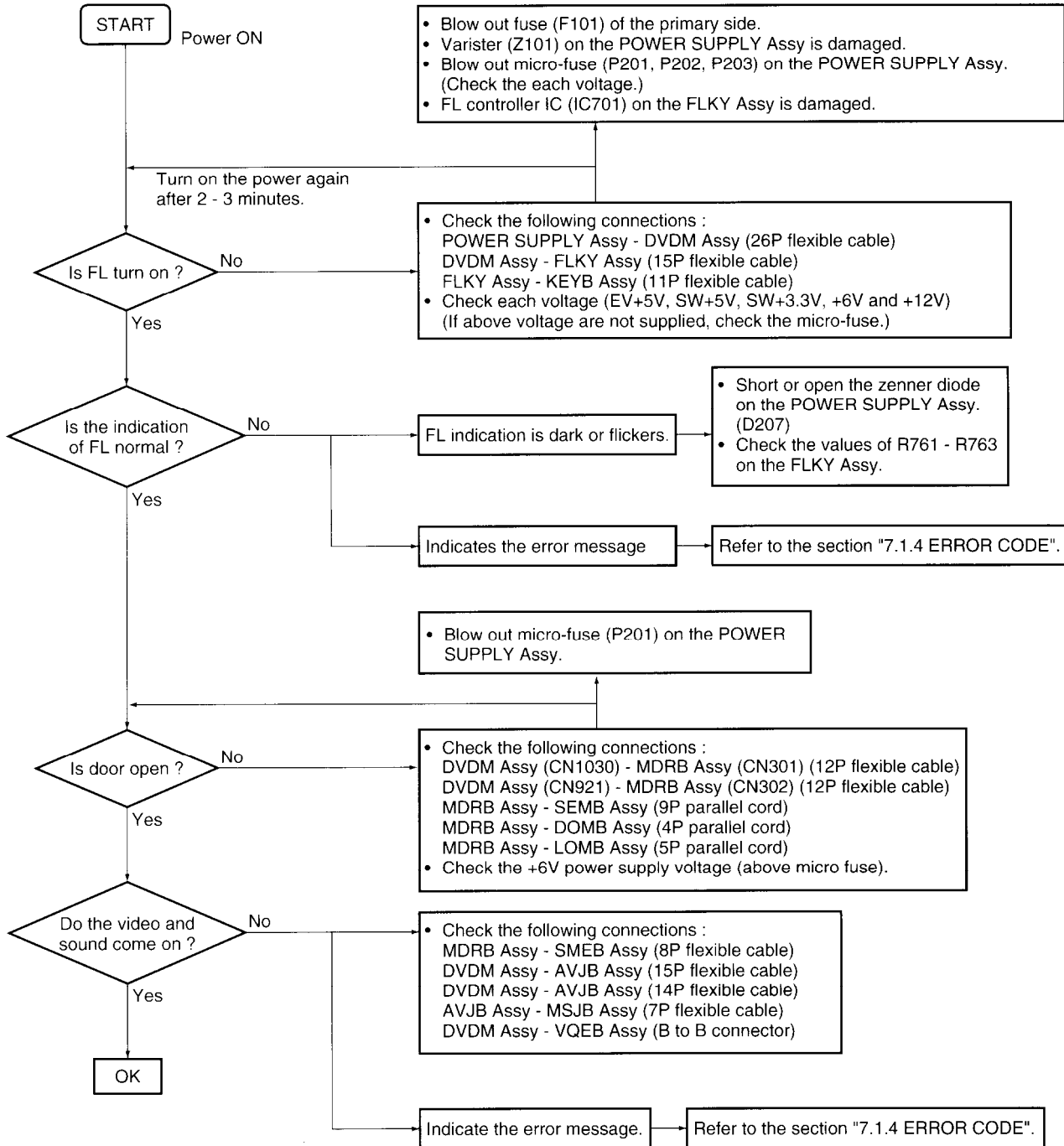

7.1.3 OPERATION FLOWCHART

• From power-on till the end of initialization

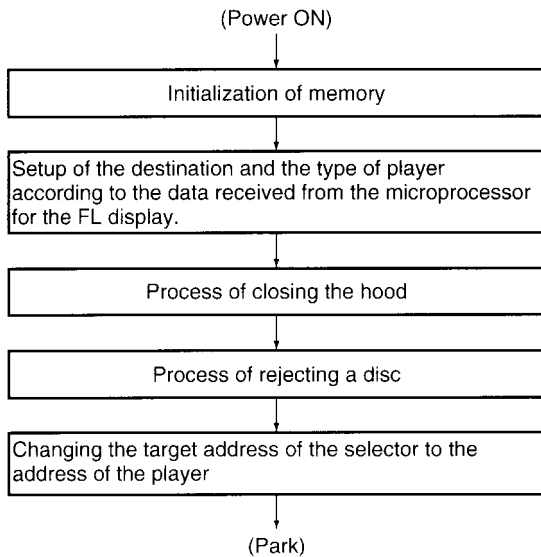

• Until start of playback of the specified disc

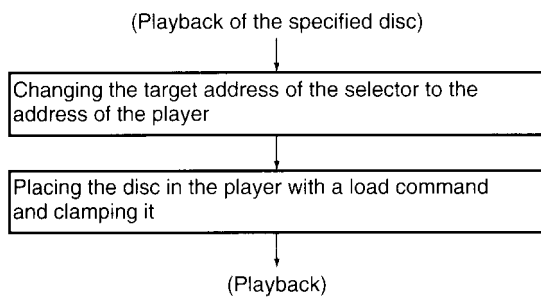

• Closing the hood

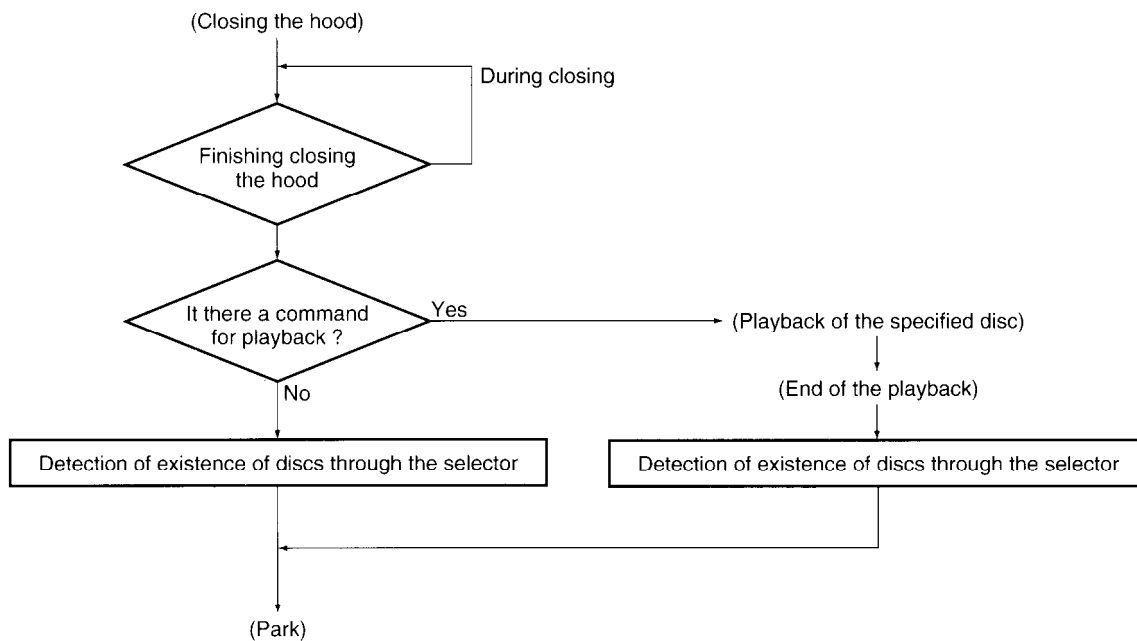

7.1.4 ERROR CODE

Error codes that are displayed on the FL display without using the remote control unit

FL Display	Possible causes	Operation of the unit
AV1 VER	AV-1 chip is not a match with the program of system controller	The sound may not out with the specific audio.
CPU AERR	CPU address error (Hardware is unusual.)	No operation
DMA AERR	DMA address error (Hardware is unusual.)	No operation
FLASH ID	Difference in versions of the internal ROM of the system controller and of the flash ROM, or bus line failure or reverse installation	No operation
FLASH WRP	Write protect error of the flash ROM	No operation
FLASH SIG	Difference in part number of the flash ROM (When the ROM which couldn't be used was used.)	No operation
FLASH SUM	Check sum error of the flash ROM (It exceeds the regular size.) or reverse installation (Hardware is unusual.)	No operation
FLASH SIZE	Size error of the flash ROM (Use 4 or 8 M-bit.)	No operation
ILLGAL	The system controller fetched a code other than an operation code (Hardware is unusual.)	No operation
RESERVE	Undefined interrupt (Hardware is unusual.)	No operation
SLOT	Inappropriate slot command issued (Hardware is unusual.)	No operation

Error codes that are displayed on the FL display by using the remote control unit (Mechanism controller error)

To display: ESC + DISPLAY + DISPLAY; Location of the display: At the two digits of center of the FL display

To display the error history: ESC + DISPLAY + One shot; Location of the display: TV screen

FL	Description of Error	Causes if with a DVD	Causes if with a CD	Operation of the Unit
11	Search timeout	Search could not be complete within 7 seconds.	Search could not be complete within 7 seconds, and it could not enter the target area within 7 seconds by VCD scan.	CD : Stops, DVD: Continues operation
12	Search retry error	A search could not be completed after 3 retries, search backup was executed 4 times, or in a case of timeout (6 seconds) while the unit was tracing 11 tracks or more beyond the target while the search operation was converging.	Backup against slider skip was executed 4 times during a search, or slider skip twice resulted in starting from the read-in point.	CD: Stops, DVD: Continues operation
19	Tracing timeout while converging	Timeout (10.5 seconds) while tracing at the stage of convergence of a search.		Stop
1B	Index 0 search error		During Track (Index) Search, the search for the beginning of a program could not be completed within 3 seconds (20 seconds in the case of Index Search) after positioning based on the TOC data was completed.	Stop
22	Timeout of slider inner circumference	Inside switch could not ON within 3 seconds.		Stop
23	Timeout of slider outer circumference	Inside switch could not OFF within 2 seconds.		Stop
33	No FOK pulse during playback CLVA	When the focus was deviated continuously 20 times.		Adjusts focus at the innermost circumference and tries to return to its position where the error was generated (for 3 times), then opens. If the same error persists after one retry, the tray opens. (No FOK pulse)
38	Disc-type-sensing error	If normal starting was impossible in the following three cases, disc-type sensing will be retried if other errors occur excepting C5 error. However, when the focus error "33" was occurred continuously 3 times, it is finished as "38 error" at the moment: (1) startup with the first disc-type-sensing result, (2) forced startup with another disc by designating the disc type, (3) forced startup with the original disc by designating the disc type.		Open

FL	Description of Error	Causes if with a DVD	Causes if with a CD	Operation of the Unit
39	SGC converge timeout	SGC could not converge during detects the peak		Open
41	Spindle timeout	The unit did not enter Stop mode within 10 seconds of issuance of a Stop command.		Stop
48	Spindle FG transition timeout	<p>The spindle could not converge into within $\pm 12\%$ of the target FG rotation speed within 10 seconds after spindle kick.</p> <p>The first time after startup (the first time after disc distinction), it doesn't become the number of the target rotation within five seconds.</p> <p>The first time after startup, detects the abnormal rotation number of high-speed continuously 3 loops. DVD: 5 to 9 mS , CD: 40 to 60 mS</p>		Stops. (FG timeout)
49	Spindle PLL transition timeout	<p>After the second times after startup, it doesn't become the number of the target rotation within five seconds.</p> <p>Detects the abnormal high-speed or low-speed rotations. DVD: 5 to 9 mS , CD: 40 to 60 mS</p>		Stops. ("73" is displayed during starting process.)
4A	Spindle lock timeout	Spindle could not lock more than 1.5 seconds before start the AFB.		Stops. ("73" is displayed during starting process.)
51	Auto sequence timeout of peak detection	ABUSY did not return within 1 second after the DDTCT (peak detection) command was sent.		Stop
52	Auto sequence timeout of focus jump down	ABUSY did not return within 30 mS after the FJMPD (Focus jump 1 to 0) command was sent.		Stop
53	Auto sequence timeout of focus jump up	ABUSY did not return within 30 mS after the FJMPU (Focus jump 0 to 1) command was sent.		Stop
54	Auto sequence timeout of play AGC	ABUSY did not return within 50 mS after the GSUMON (play-AGC-measuring) command was sent.		Stop
55	Auto sequence timeout of disc-type-sensing	ABUSY did not return within 2 seconds after the DJSRT (disc-sensing) command was sent.		Stop
56	Auto sequence timeout of ATB2	ABUSY did not return within 1 second after the TBLOFS (Internal ATB after the completion of external ATB) command was sent.		Stop
57	Auto sequence timeout of tracking servo ON	ABUSY did not return within 500 mS after the TSON (tracking servo ON) command was sent.		Stop
58	Auto sequence timeout of ATB1	ABUSY did not return within 200 mS after the TBL (external ATB) command was sent.		Stop
59	Auto sequence timeout of focus gain adjustment	ABUSY did not return within 2 seconds after the FGN (focus gain adjustment) command was sent.		Stop
5A	Auto sequence timeout of tracking gain adjustment	ABUSY did not return within 2 seconds after TGN (tracking gain adjustment) command was sent.		Stop
5B	Auto sequence timeout of offset adjustment	ABUSY did not return within 1 second after the CMDAVE (offset adjustment) command was sent.		Stop
5C	Auto sequence timeout of modulation factor measurement	ABUSY did not return within 200 mS after the ADJMIR (modulation factor measurement) command was sent.		Stop
5D	Auto sequence timeout of auto focus bias	ABUSY did not return within 2 seconds after the AFB (auto focus bias) command was sent.		Stop
5F	Auto sequence already busy	A command could not be sent because ABUSY was low. ABUSY did not return within 200 mS after TLV command was sent.		Stop
62	Pause retry error	Pause mode could not be restored within three retries after it had been released.		Continues operation

FL	Description of Error	Causes if with a DVD	Causes if with a CD	Operation of the Unit
71	ID can not read during tracing	An ID could not be read for 1 second or more.		Stop
72	Subcode check failure during playback		No frame could be read for 3 seconds or more.	Stop
73	ID can not read at the startup	An ID could not be read within 1 second after the AFB adjustment had been finished.		Opens (ID readout failure)
74	Subcode check failure during startup		No subcode could be read within 3 seconds after AFB adjustment had been finished.	Opens (Subcode readout failure).
81	Timeout for reading TOC of the mechanism controller		TOC readout took 30 seconds or more.	Stop
82	Timeout for reading TOC of the system controller		Reading TOC of the system controller took 30 seconds or more.	Stop
A1	Communication timeout of DSP command	A command could not be issued to DSP because Command Busy (XCBUSY) was in force (XCBUSY = L) for a specified time (about 200 μ S).		No operation
A2	Communication timeout for reading DSP coefficient	Command Busy (XCBUSY) was in force for a specified time (about 200 μ S) before and after a coefficient read command was issued to DSP, or the address echo-back after command issuance did not match the setup address.		No operation
A3	Communication timeout for writing DSP coefficient	Command Busy (XCBUSY) was in force for a specified time (about 1024 mS) before and after the coefficient write command was issued to DSP.		No operation
A4	Communication timeout for continuously writing DSP coefficient	Command Busy (XCBUSY) was in force for 200 μ S during continuous coefficient writing, or before and after a continuous write command was issued to DSP.		No operation
B1	Timeout error for backup	In the tracing state during the backup sequence, codes could not be read for 1 second or more. In the backup sequence, tracking ON sequence of the servo DSP could not be completed even if more than 500 mS after the tracking ON command was issued.		Stops
B2	Retry error for backup	Tracing impossible after retrying the tracking ON for 3 times in the backup sequence.		Stops
B3	Retry error for trace	During tracing, runaway was detected after three iterations of backup operations for detecting runaway.		Stops
C3	Detection of tracking overcurrent	During playback, the overcurrent detection port was at L for 300 ms or more continuously.		Stops (the mechanical controller operates independently).
(C5)	Short-circuit test corresponding error	While the power was on, the overcurrent detection port was at L for 40 ms or more continuously.		Turns off the power instantly (No indication on the FL display and no writing to flash memory)
E3	Violation against digital copy guard			Stops
F5	Tray being pushed	The tray switch that had been Open mode was forcibly changed to a mode other than Open by an external force.		Closes
F8	Loading timeout	Loading, unloading or clamping could not be completed within a specified time (about 5 seconds).		Reverses the loading direction. It timeout is repeated upon retry, the unit stops.
FC	Focus	The following error occurred eight times. (1) Focus ON sequence could not be completed even if more than two seconds after the focus ON command (to the servo DSP) was sent. (2) Focus IN sequence was finished, actually focus IN was not completed.		Stops wherever possible then opens (stops in the case of side B).

E00, E04-E06, E11, E16, E17, E90-E92, E99

: Refer to page 76.

**Error codes that are displayed on the FL display by using the remote control unit
(Device error)**

To display: ESC + DISPLAY + DISPLAY; Location of the display: At the two digits of left of the FL display

FL	Description of Error	Causes if with a DVD	Causes if with a CD	Operation of the Unit
bit3=1 08 etc.	AV1 access error (read, write NG)			No operation or it becomes debugging indication if the power is able to ON.
bit2=1 04 etc.	MY CHIP access error			
bit1=1 01 etc.	SRAM access error			

7.1.5 INTERFACE CONNECTOR

• Communication control

The protocol system is based on a system in which the computer gives commands and the player returns statuses. The communication protocol used conforms to that used by industrial and educational equipment (changers, drives, LD players for educational use, etc.) of our company, and supports Communication Mode 7 (CM 7).

CM 7 uses a method of proceeding a program by issuing each execution command and confirming the execution status with a request command.

First, the controller sends an execution command, and the player returns the status of having received the command. Then, the controller sends a request command, and the player returns the corresponding status data. The controller repeats this operation until it receives the status data required.

In CM 7, neither Completion of Execution Status nor error messages are returned. Statuses returned in response to execution commands are the End of Receive message <R> and Communication Errors <E 00>. To confirm Completion of Execution or occurrence of errors, use the request command "?J." However, note that some commands have restrictions or conditions, and that some commands cannot be executed or may not be executed as they should be.

• Format

Serial control interface in conformance with the RS-232C Standards

• Connector

15-pin, D-sub connector

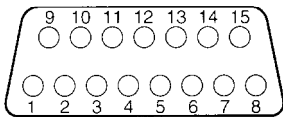

• Signal Line

No.	Name	I/O	Function
1	GND	-	Ground
2	TxD	O	Transmission output
3	RxD	I	Receiving input
4	DTR	O	Transmission permission
5	Reserved	-	_____
6	Reserved	-	_____
7	Reserved	-	_____
8	Reserved	-	_____
9	Reserved	-	_____
10	Reserved	-	_____
11	GND		Ground
12	Reserved	-	_____
13	Reserved	-	_____
14	Reserved	-	_____
15	GND	-	Ground

• Specifications of Interface

Signal level : RS-232C level

Data format

Data length : 8 bits

Stop bit : 1 bit

Parity : none

Transmission speed (baud rate):

Selectable between 9600 and 19200 bps, by exclusive command of the player. Every time the power is turned on, the baud rate is reset to 9600 bps.

Connection:

The computer and this unit are connected through three lines, as shown below:

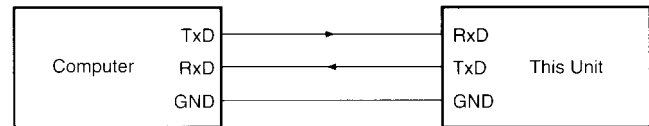

The player can receive commands any time as long as the power is on. So, even when the RS-232C port of the computer is used, connection of any control lines other than TxD and RxD is NOT necessary.

However, some computers need physical CTS input for operation. In this case, the DTR output, which always outputs positive electric potential as long as transmission is possible, can be used. Connect the DTR output to the CTS input of the computer as shown below:

Example of connection (connection with a DOS/V computer)

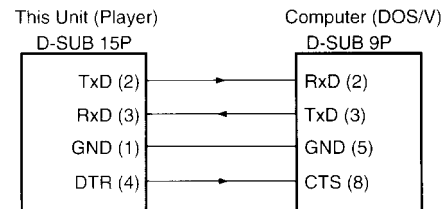

• Error List

Error Code	Error Name	Meaning	Circumstance when an error occurs
E00	Communication Error	A communication error was generated between the player and the host computer.	A string of commands exceeded the defined buffer size.
E04	Command Error	An inappropriate command string was detected.	An undefined command was issued or a command was issued at inappropriate timing.
E05	Request Error	A request command was detected at inappropriate timing.	A request command was issued in circumstances where a status signal could not be returned.
E06	Argument Error	Inappropriate argument, or argument missing	The argument was out of range or missing
E11	No Disc Error	No disc	No disc in the specified location, or a command was issued without a disc present.
E16	Key Input Error	There was key input at inappropriate timing.	Because of a key input through the remote control unit, for example, during execution of a command, the execution of the command was interrupted.
E17	GUI Menu Error	The GUI menu is displayed, or the unit entered GUI Menu mode during execution of a command.	The normal command was issued while the GUI Menu was already on-screen, or the GUI Menu was being output to the screen during execution of a command.
E90	Connect Error	Connection error of the master and slave players	Connections are not correct.
E91	Slave Player Error	A direct command from the host computer to a slave player was detected.	The host computer is connected to the slave player.
E92	Master-Slave Error	Communication error between the master player and the slave player(s)	Whether a command to the slave player(s) was issued correctly or not could not be confirmed.
E99	Panic Error	An error was generated, and playback could not be continued.	An error in the mechanical control system or the servo system was generated, and continuation of playback became impossible.

• Notes

Normal operation

- Some operations in Search mode are prohibited for some discs. In such a case, an error is not generated when the mode is specified, but an error is generated when execution of the SE command is attempted.
- Always use the ZS command at the beginning of a command string.
- To use the ZS command during setup (PLAYER ACTIVE STATUS = P03,) always use the ZR command before the ZS command.
- If a disc does not exist at the location specified by the ZS command, playback of the disc in the next location in numerical sequence is executed if it is before the location of no-disc detection. If it is after the location of no-disc detection, a "No Disc Error" (E11) is generated.
- If an RJ command is issued during startup of the disc, the disc is returned to the rack, as with the ZR command.
- During GUI Menu mode (during Setup or Sub-Set-up mode,) normal commands, the NI command, or AI command cannot be accepted. If GUI Menu mode is entered during execution of a command, only normal commands are canceled. Other commands can be accepted during GUI Menu mode.
- Repeat mode is canceled if the SE command is executed.
- If the KO command is issued before location of no-disc detection, an error is generated, and the error code is displayed.
- The setting of Repeat mode is disabled in playback mode (Status is PIX with ?P).
- If an impossible OSD display item is specified (for example, if time display is specified for a DVD for which time data are not available) with the DS command, an error is generated, and the error code is displayed.
- The NI and AI commands are effective only when the disc type has been detected (except for NO DISC and UNKNOWN). disc type can be checked using the KO command.

Operation with master-slave communication

- If the disc is being returned to the rack with the ZS command, etc., while a slave player is operating, the master player will assume success of the operation.
- The "End of Receive" Status (R) is generated by the master player. If a communication error is generated between the master and a slave player, only the error data item "E92" is stored, and the error code "E00" will not be returned to the host computer.
- The OP, UL, and CO commands apply to only the master player even during Slave Player Operation mode. That is, opening/closing of the hood of a slave player cannot be controlled with RS-232C commands.
- Any part of a command string after the ZR and RJ commands sent to a slave player is ignored.
- A request command to the slave player(s) takes 0.5 seconds at maximum. The ?T and ?A commands are exceptions, and return status data immediately.
- The ?T and ?A commands during Stop mode, etc., will generate errors if issued to the master player. But this is not the case for the slave player(s), and time data are always transmitted.
- If any connection error is detected between the master and slave players, the player returns a "E92" code once in response to any command. Afterwards, the players will not accept any commands.
- If the host computer is connected to the slave player, the player returns a "E92" code once in response to any command. Afterwards, the players will not accept any commands.
- Allow at least 0.5 second (1 second recommended) between commands to the slave player(s), except for the ?A, ?T, NI, AI, NO, AO, KO, and ID commands.
- No command can be accepted during the first approximately 3 seconds after the power is turned on.

7.1.6 DISASSEMBLY

■ Bonnet

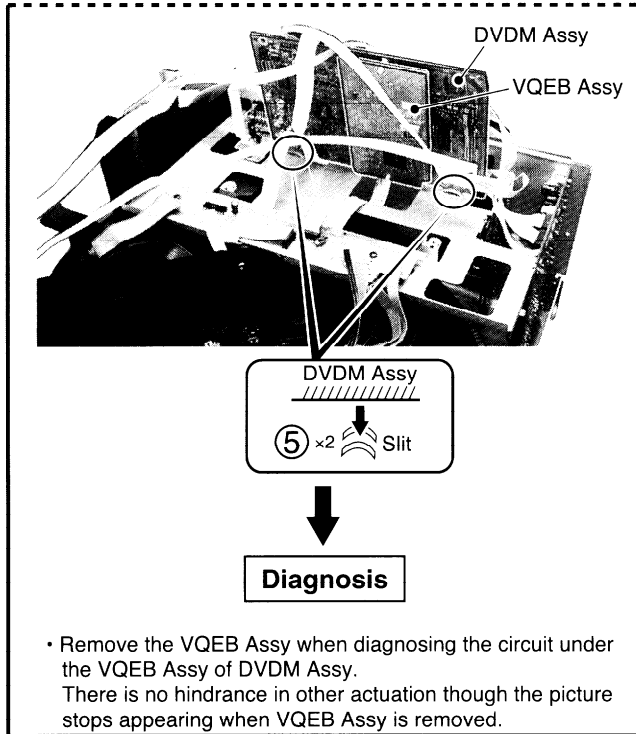
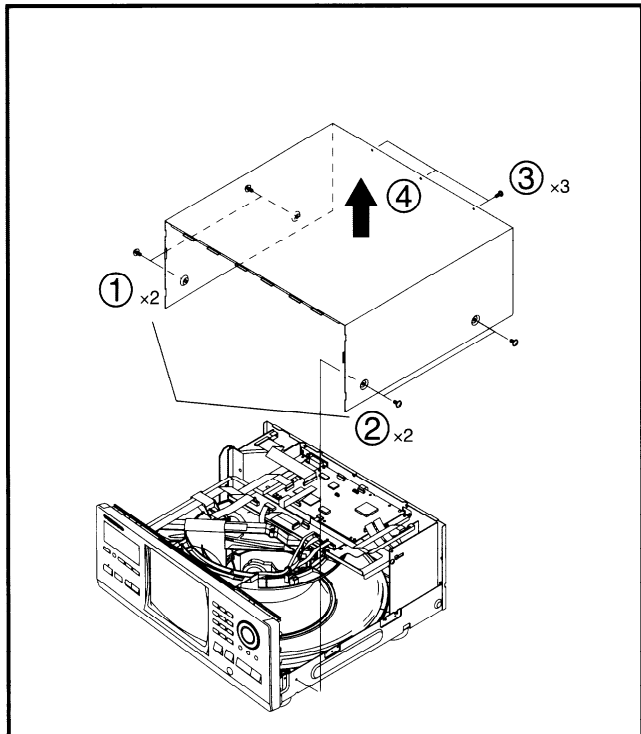

■ DVDM Assy

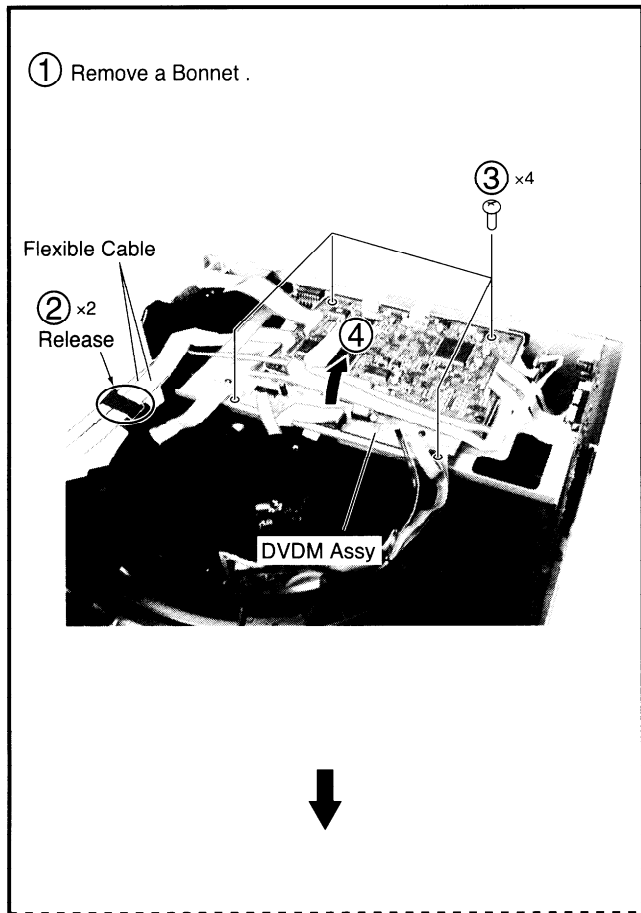

■ Traverse Mechanism Assy

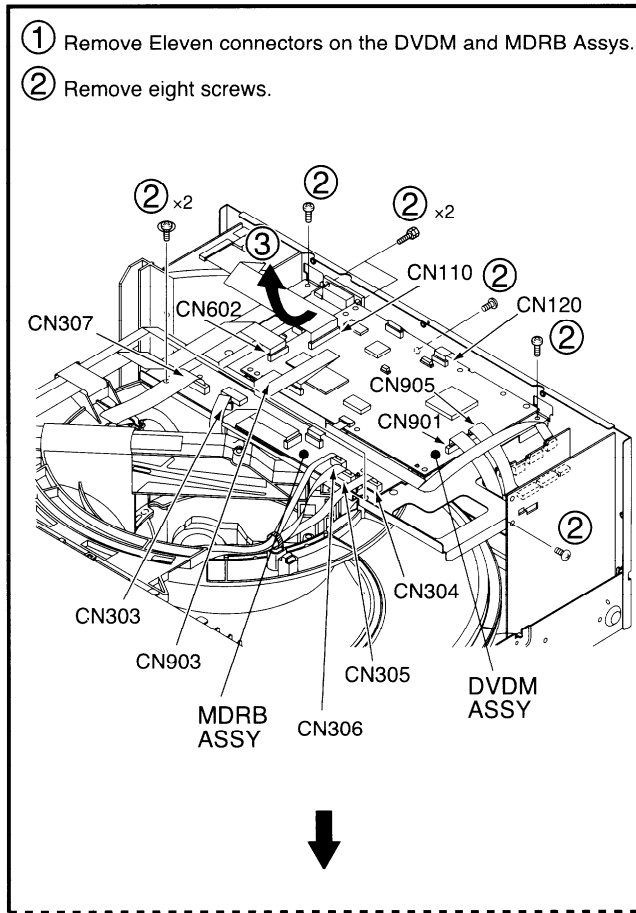

• List of Commands

Mnemonic	Command Name	Argument	Job
OP	OPEN	-	Opens the hood.
UL	UNLOAD	0 - 300	Moves the specified disc to the front and opens the hood.
CO	CLOSE	-	Closes the hood and detects the existence of discs.
ZS	DISC SELECT	0 - 300 (600)	Executes playback of the specified disc.
RJ	REJECT	-	1st time: Stops playback. 2nd time: Returns the disc to the rack.
ZR	DISC RETURN	-	Returns disc being played to the rack.
PL	PLAY	-	Executes playback.
KP	1 TRACK PLAY	-	During one-track playback, the status becomes busy.
PA	PAUSE	-	Pauses playback temporarily and displays a still picture.
ST	STILL	-	Pauses the playback temporarily.
SF	STEP FORWARD	-	Plays back picture forward frame by frame.
SR	STEP REVERSE	-	Plays back picture in reverse frame by frame.
NF	SCAN FORWARD	-	Scans picture forward (scanning mode is locked).
NR	SCAN REVERSE	-	Scans picture in reverse (scanning mode is locked).
NS	SCAN STOP	-	Stops scanning and returns to the normal playback mode.
SE	SEARCH	See below.	Executes search. (Arguments differ from mode to mode.)
TM	TIME MODE SET	MMMSS	Sets search by time (M: minute, S: second).
CH	CHAPTER MODE SET	1 - 99	Sets search by chapter.
TI	TITLE MODE SET	1 - 99	Sets search by title.
TR	TRACK MODE SET	1 - 99	Sets search by track.
SU	SELECT SUBTITLE	0 - 32, None	Switches to the specified subtitle. (0 or none: OFF)
AU	SELECT AUDIO	1 - 8	Switches to the specified audio.
AG	SELECT ANGLE	0 - 9	Switches to the specified angle.
AP	SELECT ASPECT	1 - 3	Switches aspects either to 1 (Pan & Scan), 2 (Letter Box), or 3 (wide).
RP	REPEAT MODE SET	0 - 3	Execute Repeat mode of the following: 0 (OFF), 1 (TRACK), 2 (DISC), or 3 (FUNCTION).
DS	DISPLAY CONTROL	0 -5, None	Displays the specified OSD. (0: OSD OFF, none: equivalent to key input from the remote control unit)
CL	CLEAR	-	Cancels the function input, Repeat mode, and Function mode in this order.
PM	PLAY MODE SET	0 - 1	Sets the playback mode to 0 (All Discs) or 1 (Single Disc).
CP	CUSTOM PLAY SET	1 - 20	1-10: Audio 1-10 mode, 11-20: Video 1-10 mode
UD	AUTO UPDATE	1 - 2	Executes the following: 0 (Additional Update) or 1 (All Update)
BC	BAUD RATE CHANGE	0 -1	Switches the transmission speed to 0 (9600 bps) or 1 (19200 bps).
ID	DISC-ID OUTPUT	1 - 300 (600)	Outputs distinction data for the specified disc.
KO	DISC TYPE OUTPUT	1 - 300 (600)	Outputs disc type data for the specified disc.
NI	DISC TEXT INPUT	1 - 300 (600)	Inputs title data for the specified disc.
AI	ARTIST TEXT INPUT	1 - 300 (600)	Inputs artist's name data for the specified disc.
NO	DISC TEXT OUTPUT	1 - 300 (600)	Outputs title data for the specified disc.
AO	ARTIST TEXT OUTPUT	1 - 300 (600)	Outputs artist's name data for the specified disc.
?J	JOB STATUS REQUEST		Returns the operational status of the execution command (R: finished, B: busy, EXX: error).
?P	PLAYER AVTIVE STATUS REQUEST		Returns the operational status of the player (PXX: XX = operational status).
?Z	DISC NUMBER REQUEST		Returns the number of the disc being played back.
?E	ERROR REQUEST		Returns the latest error code (EXX: XX = Error code).
?T	TIME CODE REQUEST		Returns the time from the beginning of the TITLE/DISC to the current point (MMMSS: M = minute, S = second).
?R	TITLE/TRACK NUMBER REQUEST		Returns the TITLE/TRACK No. being played back.
?C	CHAPTER REQUEST		Returns the chapter No. being played back.
?A	PLAY TIME REQUEST		Returns the current playback time (TTCCMMSSS: T = title, C = chapter).
?K	DISC TYPE REQUEST		Returns the disc type (00: unknown, 01: none, 02: CD, 10: DVD, 40: VCD)
?H	PLAYER MODE REQUEST		Returns the player mode (XX: second digit = Play mode, first digit = Repeat mode).
?M	COMMUNICATION MODE REQUEST		Returns the communication mode (CM 7 : always Mode 7).
?X	PLAYER MODEL NAME REQUEST		Returns the player model distinction number (P1560XX: XX = version)

Argument: Argument of a command. The values in parentheses are those when the slave player(s) is(are) connected, and "0" stands for a single loader.

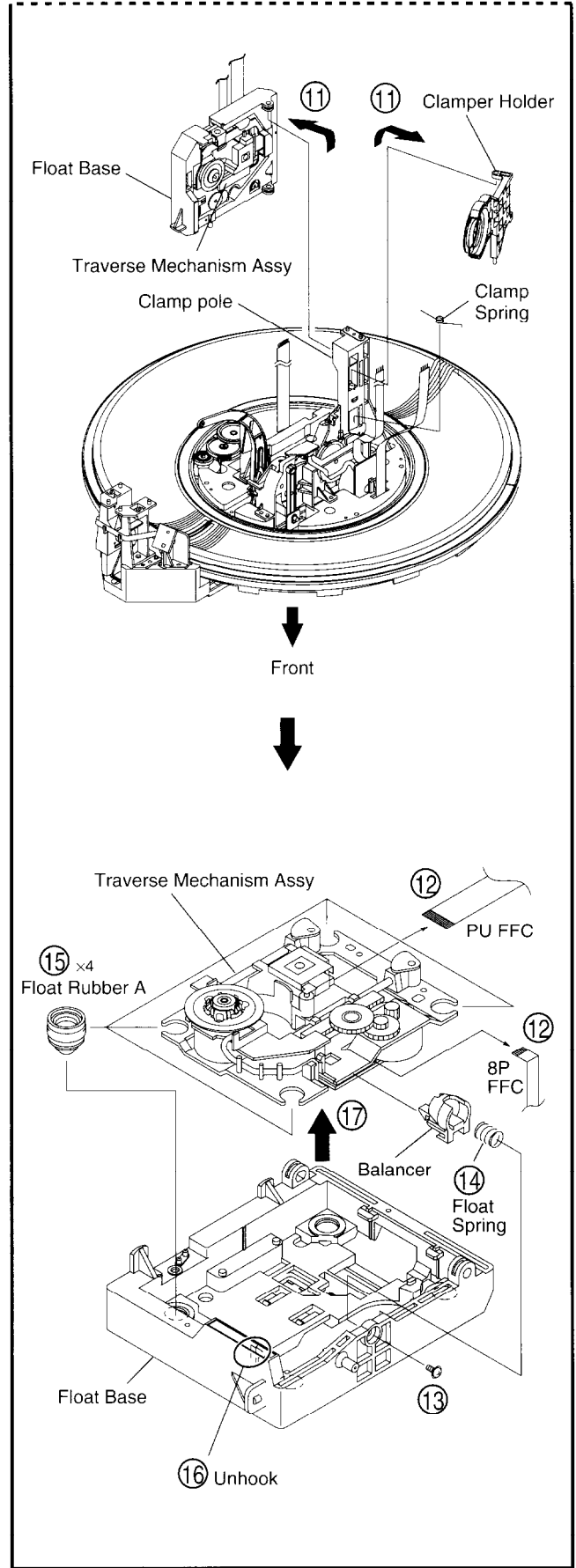
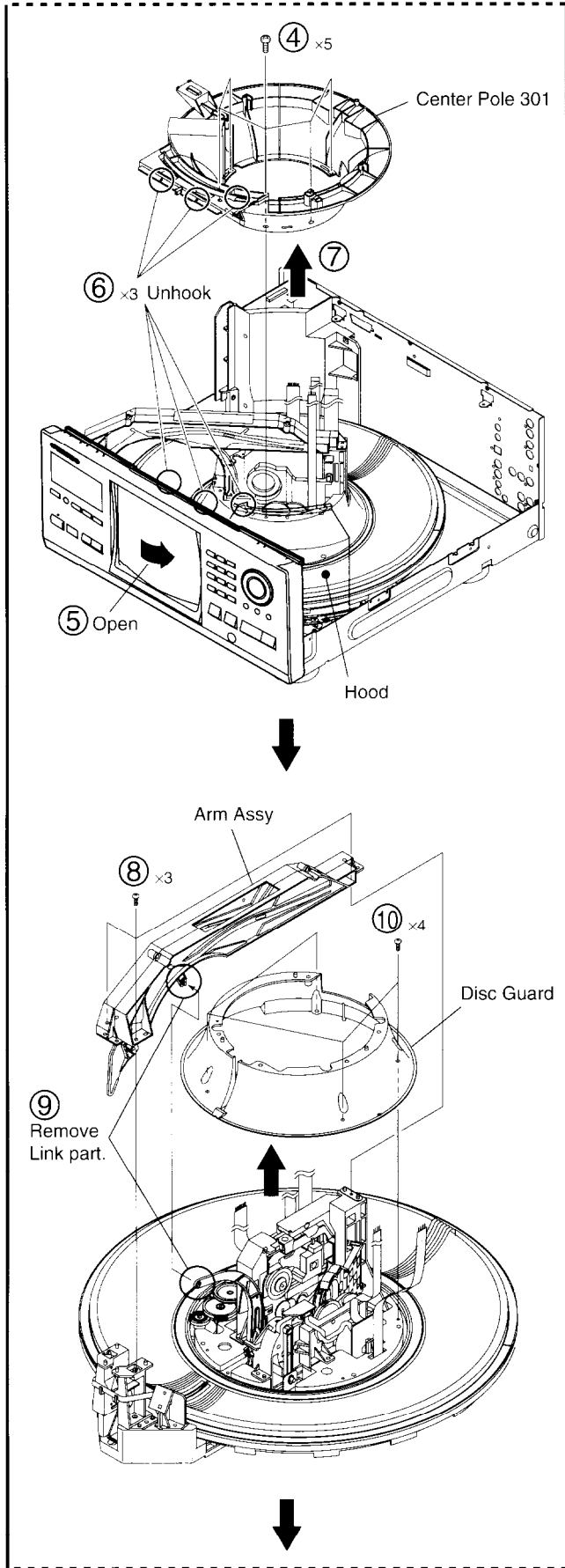

■ Gear Holder Assy and Disc Rack

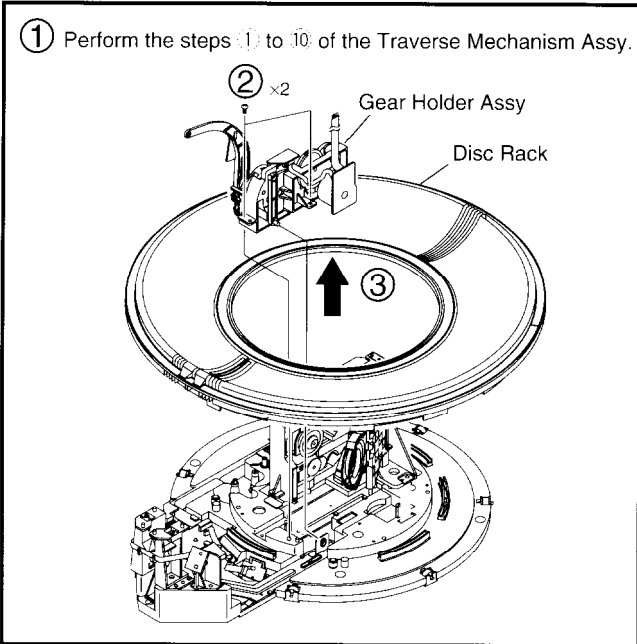

■ Hood and Hood Base Assy

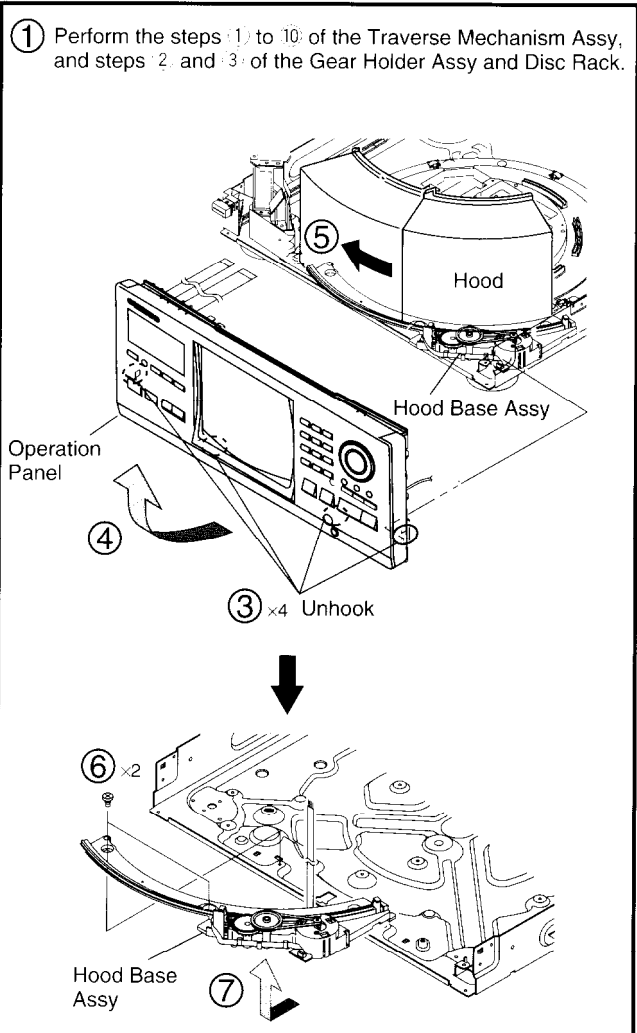

7.1.7 ABOUT SERVICE IN THE MECHANISM FAILURE

- Draw two discs of CD
- Pin of (A) portion in the figure deviates from the groove of cam
- Arm comes off

When a symptom of the above (mechanism failure, etc.) was occurred, perform the check of following items in the Check Table with repair of failure section simultaneously.

Check Table

	Item	Check
1	Does Roller B installs it justly?	
2	Does Disc Divider installs it justly?	
3	Does Clamp Spring installs it justly or hang it?	
4	Does Drive Arm Spring installs it justly or hang it?	
5	Does hook of Link L installs to the Gear Holder justly?	

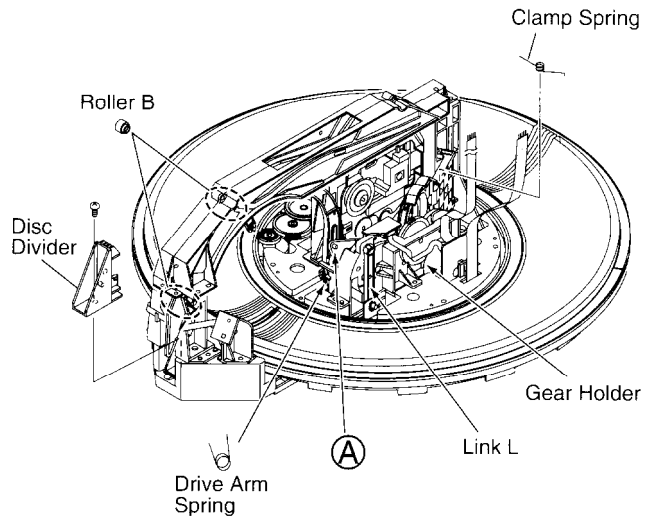

7.2 PARTS

7.2.1 IC

• The information shown in the list is basic information and may not correspond exactly to that shown in the schematic diagrams.

• **List of IC**

LC78652W, PD3410A, VYW1668, M65773AFP, PM0023AF, CY2081SL-655

■ **LC78652W (DVDM ASSY : IC201)**

• **DSP IC**

• **Block Diagram**

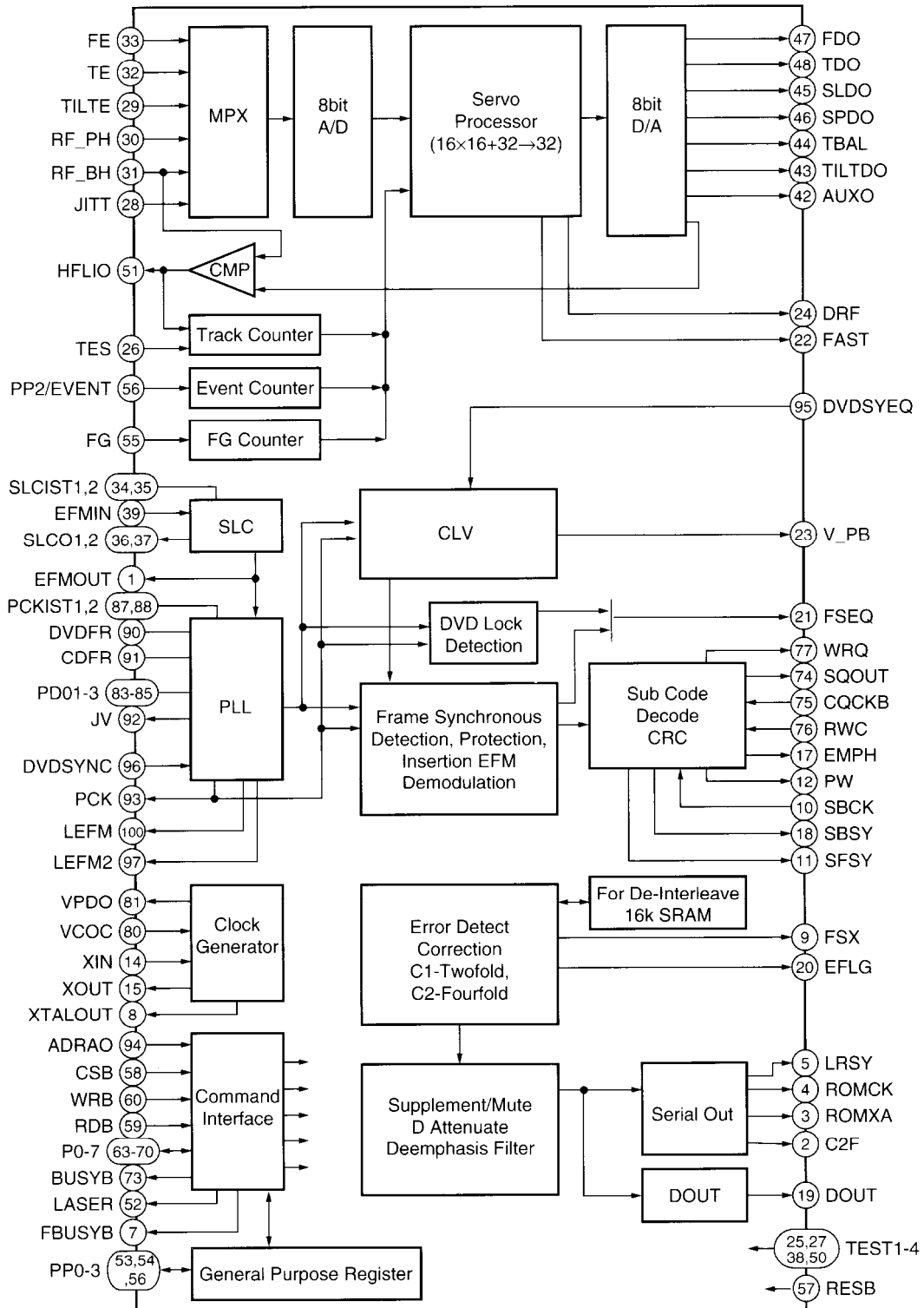

• Pin Function

No.	Pin Name	I/O	Function
1	EFMOUT	O	Output the state that was binary-stated value EFM
2	C2F	O	C2 flag output
3	ROMXA	O	CD-ROM data output
4	ROMCK	O	Shift clock output for CD-ROM data output
5	LRSY	O	L/R clock output for CD-ROM data output
6	PP3	I/O	General-purpose port input/output / DVD sync. signal input N ch-OD output
7	FBUSYB	O	Busy signal output of DSP process operation N ch-OD output
8	XTALOUT	O	External system clock output
9	FSX	O	CD 1 frame sync. signal output
10	SBCK	I	Subcode reading out clock input
11	SFSY	O	Frame sync. signal output of subcode
12	PW	O	Subcode P, Q, R, S, T, U, V and W output
13	VSS	-	GND pin
14	XIN	I	Connect a crystal resonator (16.9344MHz)
15	XOUT	O	Connect a crystal resonator
16	DVDD1	-	3.3V power supply of the oscillation circuit
17	EMPH	O	Monitor pin of the deemphasis
18	SBSY	O	Sync. signal output of the subcode block
19	DOUT	O	Audio EIAJ data output
20	EFLG	O	Error correction state monitor of the error correction C1 and C2
21	FSEQ	O	Detection monitor of the CD/DVD frame sync. signal
22	FAST	O	Playback speed monitor N ch-OD output
23	V_PB	O	Monitor output of the rough servo/CLV control
24	DRF	O	In focus monitor
25	TEST3	I	Test input 3
26	TES	I	Tracking error signal input
27	TEST2	I	Test input 2
28	JITT	I	Jitter quantity detecting signal input of EFM PLL
29	TILTE	I	Tilt error signal input
30	RF_PH	I	RF peak hold signal input
31	RF_BH	I	RF bottom hold signal input
32	TE	I	Tracking error signal input
33	FE	I	Focus error signal input
34	SLCIST1	-	Current setting pin 1 of the constant current charge pump for SLC
35	SLCIST2	-	Current setting pin 2 of the constant current charge pump for SLC
36	SLCO1	O	Control output 1 for SLC
37	SLCO2	O	Control output 2 for SLC
38	TEST1	I	Test input 1
39	EFMIN	I	EFM/EFM + input
40	AVDD	-	5V power supply of A/D and D/A for servo
41	AVSS	-	GND of A/D and D/A for servo
42	AUXO	O	DA auxiliary output
43	TILTDO	O	Tilt control signal output
44	TBAL	O	Tracking balance control signal output
45	SLDO	O	Sled control signal output
46	SPDO	O	Spindle control signal output
47	FDO	O	Focus control signal output
48	TDO	O	Tracking control signal output
49	VREF	-	Reference level of D/A for servo
50	TEST4	I	Test input 4

■ PD3410A (DVDM ASSY : IC601)

• System Control IC

● Pin Function

No.	Mark	Pin Name	I/O	Function
1	XCS3/XCASL	XCS3	O	PD4995A (MY CHIP) chip select signal output
2	GND	GND	-	GND
3	CK	HCPUCK	O	
4	VCC	V+3D	-	V+3D
5	PICLK	-	I/O	N.C.
6	PIDATA	-	I/O	N.C.
7	GND	GND	-	GND
8	PORTH0	XCSSP0	O	
9	PORTH1	33MVH	O	
10	PORTH2	36MVH	O	
11	PORTH3	V_SEL2	O	Composite/S switching signal output of the skirt terminal
12	VCC	V+3D	-	V+3D
13	PORTH4	SCTAON	O	
14	PORTH5	27MVH	O	
15	PORTH6	XCSSPD	O	
16	PORTH7	XAUDRST/ VPOFF/ ECHO	O	YSS922 (Dolby AC-3/Pro logic, audio DSP built-in DTS decoder) Video system
17	GND	GND	-	GND
18	EXTAL	EXTAL	I	Connect a ceramic resonator
19	XTAL	XTAL	O	
20	VCC	V+3D	-	V+3D
21	PORTG0	XCSDFO	O	DAC chip select signal output
22	PORTG1	XCSDF1/ XCSDASP	O	YSS912 (Dolby AC-3/Pro logic, audio DSP built-in DTS decoder) AD1853 (3D audio processor) TC74VHC595FT (Serial/parallel) → SM5847AF (DAC for Mch) YSS922 (DASP)
23	PORTG2	XCSDF2/ DFRST1/ XMIC_ON	O	YSS912 (Dolby AC-3/Pro logic, audio DSP built-in DTS decoder) SM5847AF (DAC for Mch)
24	PORTG3	HIBSEL	O	PD0236AM
25	PORTG4	LFEON/ DFRST0	O	Buffer → Audio amp SM5847AF (DAC for Mch)
26	GND	GND	-	GND
27	PORTG5	6CHMD/ XMAOFF	O	Buffer → Front DAC selector
28	PORTG6	DTSMO/ XMRST/ XDASP	O	SW (Switch circuit)
29	PORTG7	XAMUTE/ XMUTM	O	Last stage mute signal output of the audio
30	PORTF0	44X48	O	DAC 44/48 FS switching signal output
31	PORTF1	DI_ERR/ XDIGIO	I	DIR1700 (Digital audio interface receiver)
32	PORTF2	3DON/ XMMUTE/ 48X44	O	
33	VCC	V+3D	-	V+3D
34	PORTF3	XCSADSP0/ SYNC1	I	CD deck synchronous input
35	PORTF4	XCSADSP1/ XAVS_RT/ DISC	I	Disc detection input
36	PORTF5	XCSADSP2/ DPOS/ODD	I	Disc position detection input

No.	Mark	Pin Name	I/O	Function
37	PORTF6	XVQERST/ XANR	O	VQE4 reset output
38	PORTF7	XCSVE/ XCSVQE	O	Serial communication enable signal output of the video encoder
39	GND	GND	-	GND
40	AVSS	GND	-	GND
41	AVCC	V+3D	-	V+3D
42	OUTA_P	LODRV	O	Loading drive output
43	VREF	V+3D	-	V+3D
44	OUTB_P	TEI	O	Tracking offset signal output
45	AVSS	GND	-	GND
46	AVSS	GND	-	GND
47	PORTE0	V_SEL	O	Component/composite switching signal output
48	PORTE1	CDGM	I	PDC016A (Graphic IC)
49	PORTE2	OEM???	I	
50	PORTE3	FOFST1	I/O	Focus offset adjustment output 1
51	PORTE4	FOFST2	I/O	Focus offset adjustment output 2
52	PORTE5	XDFINH	I/O	Defect shunt signal output
53	PORTE6	DVD/XCD	O	DVD/CD switching signal output
54	PORTE7	LD1_ON	O	650 nm laser diode ON signal output
55	PORTD0	LD2_ON	O	780 nm laser diode ON signal output
56	VCC	V+3D	-	V+3D
57	PORTD1	DPD/TE	O	1 beam/3 beams switching signal output
58	PORTD2	AGOFF	O	AGC ON/OFF switching signal output of RF IC
59	PORTD3	XCD2X	O	Signal output for switching the double speed playback
60	PORTD4	OEICG	O	OEIC gain switching signal output
61	GND	GND	-	GND
62	PORTD5	XMON	O	Control output ON/OFF switching output of the spindle motor
63	PORTD6	XBCA	O	
64	PORTD7	OPEN_SW/ X??RST	I	Mechanism connector
65	PORTJ0	XDRVMUT	O	Driver mute output
66	PORTJ1	DR/XLD	O	TC7W53F (Analog SW)
67	PORTJ2	XDSPRST	O	LC78652W (Servo DSP)
68	PORTJ3	MNJACK/ MC_MO	I/O	LA6531
69	VCC	V+3D	-	V+3D
70	PORTJ4	TM_ENT	I	Test mode input
71	PORTJ5	XEXPE	O	TC74VHCT574F/FS (3-state buffer)
72	PORTJ6	VSEL_SW	I	Component/composite SW input
73	PORTJ7	DQSY	I	Timing input of CD TEXT DAT
74	PB0/TIOCA2	XCBUSY	I	Command busy input
75	PB1/TIOCB2	XABUSY	I	Auto-sequence busy input
76	PB2/TIOCA3	XINT2/ XAVIRQ2	I	Interrupt input 2 (AV-1)
77	VCC	V+3D	-	V+3D
78	PB3/TIOCB3	LT1	O	Communication response signal output to the FL controller
79	PB4/TIOCA4	SBSY	I	Subcode block sync. input
80	XMTEST	-	I	V+3D
81	XCPUMD	-	I	V+3D
82	XRES	XRESET	I	Reset input

No.	Pin Name	I/O	Pin Function
51	HFLIO	I/O	Mirror detection signal input/output
52	LASER	O	Output pin for laser ON/OFF control
53	PP0/DVD_CDB	I/O	General-purpose port input/output / Disc discrimination signal output
54	PP1/CRCERRB	I/O	General-purpose port input/output / Subcode CRC result signal output
55	FG	I	FG counter input
56	PP2/EVENT	I/O	General-purpose port input/output / Event counter input
57	RESB	I	Reset input
58	CSB	I	Chip select input
59	RDB	I	Internal state reading signal input
60	WRB	I	Command / data writing signal input
61	DVDD2	-	5V power supply
62	VSS	-	GND
63	P0	I/O	Command / data input/output
64	P1		
65	P2		
66	P3		
67	P4		
68	P5		
69	P6		
70	P7		
71	VSS	-	GND
72	DVDD1	-	3.3V power supply for internal
73	BUSYB	O	Busy signal output of command process
74	SQOUT	O	Serial output of subcode Q
75	CQCKB	I	Shift clock input for subcode Q data output
76	RWC	I	Update permission input of subcode Q
77	WRQ	O	Read out ready monitor of subcode Q
78	AVSS	-	PLL GND for internal system clock
79	VRPFR	-	VCO oscillation range setting of PLL for system clock
80	VCOC	I	Connect a PLL filter for system clock
81	VPDO	O	
82	AVDD	-	PLL 5V power supply for system clock
83	PDO1	I/O	PLL filter connection pin 1 for EFM playback
84	PDO2	I/O	PLL filter connection pin 2 for EFM playback
85	PDO3	I/O	PLL filter connection pin 3 for EFM playback
86	AVSS	-	PLL GND for EFM playback
87	PCKIST1	-	Current setting 1 of PLL constant current charge pump for EFM playback
88	PCKIST2	-	Current setting 2 of PLL constant current charge pump for EFM playback
89	AVDD	-	PLL 5V power supply for EFM playback
90	DVDFR	-	VCO oscillation range setting of PLL for EFM playback 1
91	CDFR	-	VCO oscillation range setting of PLL for EFM playback 2
92	JV	O	Jitter output of PLL clock for EFM playback
93	PCK	O	Bit clock output for EFM playback
94	ADRAO	I	Address input
95	DVDSYEQ	I	DVD synchronize pulse input
96	DVDSYNC	I	DVD synchronous signal input
97	LEFM2	O	Output the state that cut and out a signal which was binary-stated value EFM with PCK 2
98	DVDD1	-	3.3V power supply for I/O
99	VSS	-	GND
100	LEFM	O	Output the state that cut and out a signal which was binary-stated value EFM with PCK 1

No.	Mark	Pin Name	I/O	Function
83	GND	GND	-	GND
84	AN0	LODPOS	I	Loading position input
85	AN1	SLDPOS	I	Slider position input
86	AN2	DOORSW	I	Mecha. connector
87	AN3	NAP_SW	I	NTSC/AUTO/PAL SW input
88	AN4		I	
89	AN5		I	
90	AN6		I	
91	AN7	525IP_SW	I	
92	Avref	V+3D	-	V+3D
93	AVCC	V+3D	-	V+3D
94	AVSS	GND	-	GND
95	PB5/TIOCB4	DIBLK/HFL/ DCNT2	I	Disc count input
96	PB6/TIOCXA4/TCLKC	C2F	I	C2 error input
97	PB7/TIOCB4/TCLKD	XRDY	I	Communication request input from the FL controller
98	PB8/RxD0	SSI	I	Serial data input (FL controller)
99	PB9/TxD0	SSO	O	Serial data output (FL controller, DAC)
100	VCC	V+3D	-	V+3D
101	PB10/RxD1	RXD	I	Data input of the RS-232C
102	PB11/TxD1	TXD	O	Data output of the RS-232C
103	PB12/XIRQ4/SCK0	SSCK	I/O	Serial clock output (FL controller, DAC)
104	PB13/XIRQ5/SCK1	XIRQL10	I	Interrupt input 1 (MY CHIP)
105	GND	GND	-	GND
106	PB14/XIRQ6	XIRQL11	I	Interrupt input 2 (MY CHIP)
107	PB15/XIRQ7	XINT0/ XAVIRQ0	I	Interrupt input 0 (AV-1)
108	PA0/XCS4/TIOCA0	XCS4	O	Servo DSP chip select signal output
109	PA1/XCS5/XRAS	N.C.	O	Non connection
110	PA2/XCS6/TIOCB0	XCS6	O	AV-1 chip select signal output
111	XWAIT	XWAIT	I	Wait signal input
112	XWRL	XWRL	O	Write pulse output L
113	GND	GND	-	GND
114	XWRH	XWRH	O	Write pulse output H
115	XRD	XRD	O	Read pulse output
116	PA7/XBACK	XCURDET	I	Over-current detection signal input
117	PA8/XBREQ	CTS	I	RS-232C transfer permit input
118	PA9/XAH/XIRQOUT/ XADTRG	DTR	O	RS-232C transfer permit output
119	PA10/DPL/TIOCA1	XAVIRQ1/ XINT1	I	Interrupt input 1 (AV-1)
120	PA11/DPH/TIOCB1	THLD	I	Tracking hold signal input
121	VCC	V+3D	-	V+3D
122	PA12/XIRQ0/DACK0/ TCLKA	DACK0	O	DMA response output (MY CHIP)
123	PA13/XIRQ1/ XDREQ0/TCLKB	XDREQ0	I	DMA request input (MY CHIP)
124	PA14/XIRQ2/XDACK1	XDACK1	O	DMA response output (AV-1)
125	PA15/XIRQ3/XDREQ1	XDREQ1	I	DMA request input (AV-1)
126	AD0	D0	I/O	Data bus 0

No.	Mark	Pin Name	I/O	Function
127	GND	GND	-	GND
128	AD1	D1	I/O	Data bus 1
129	AD2	D2	I/O	Data bus 2
130	AD3	D3	I/O	Data bus 3
131	AD4	D4	I/O	Data bus 4
132	AD5	D5	I/O	Data bus 5
133	AD6	D6	I/O	Data bus 6
134	VCC	V+3D	-	V+3D
135	AD7	D7	I/O	Data bus 7
136	AD8	D8	I/O	Data bus 8
137	AD9	D9	I/O	Data bus 9
138	AD10	D10	I/O	Data bus 10
139	GND	GND	-	GND
140	AD11	D11	I/O	Data bus 11
141	AD12	D12	I/O	Data bus 12
142	AD13	D13	I/O	Data bus 13
143	AD14	D14	I/O	Data bus 14
144	VCC	V+3D	-	V+3D
145	AD15	D15	I/O	Data bus 15
146	A0 (XHBS)	A0	O	Address bus 0
147	A1	A1	O	Address bus 1
148	A2	A2	O	Address bus 2
149	GND	GND	-	GND
150	A3	A3	O	Address bus 3
151	A4	A4	O	Address bus 4
152	A5	A5	O	Address bus 5
153	A6	A6	O	Address bus 6
154	A7	A7	O	Address bus 7
155	A8	A8	O	Address bus 8
156	A9	A9	O	Address bus 9
157	A10	A10	O	Address bus 10
158	A11	A11	O	Address bus 11
159	A12	A12	O	Address bus 12
160	A13	A13	O	Address bus 13
161	A14	A14	O	Address bus 14
162	A15	A15	O	Address bus 15
163	A16	A16	O	Address bus 16
164	A17	A17	O	Address bus 17
165	VCC	V+3D	-	V+3D
166	A18	A18	O	Address bus 18
167	A19	A19	O	Address bus 19
168	A20	A20	O	Address bus 20
169	A21	A21	O	N.C.
170	XNMI	XNMI	I	V+3D
171	GND	GND	-	GND
172	XCS10	XCS10	O	VHCT574F/FS (3-state buffer)
173	XCS20	XCS20	O	Chip select signal output of the flash ROM
174	XCS22	XCS22	O	(GUI ROM)
175	XCS23	XCS23	O	Chip select signal output of the SRAM
176	XCS2		O	N.C.

■ VYW1701 (DVDM ASSY : IC603)

• 16M bit Flash Memory IC

● Block Diagram

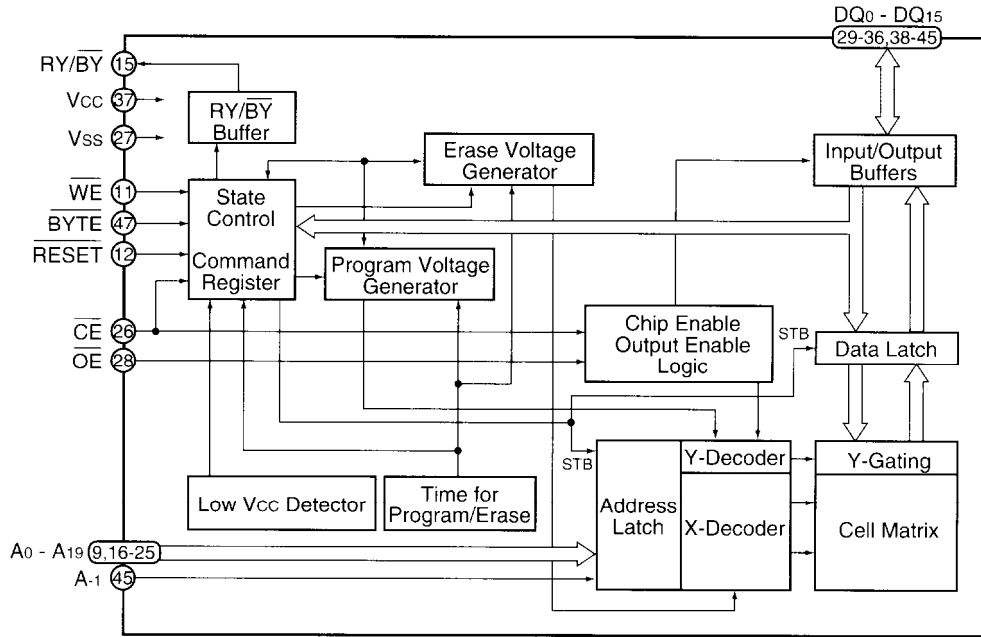

● Pin Function

No.	Pin Name	I/O	Pin Function	No.	Pin Name	I/O	Pin Function
1	A15	I	Address inputs	25	A0	I	Address input
2	A14			26	CE	I	Chip enable
3	A13			27	VSS	-	Ground
4	A12			28	OE	I	Output enable
5	A11			29	DQ0	I/O	Data inputs/outputs
6	A10			30	DQ8		
7	A9			31	DQ1		
8	A8			32	DQ9		
9	A19			33	DQ2		
10	N.C.	-	Non connection	34	DQ10		
11	WE	I	Write enable	35	DQ3		
12	RESET	I	Hardware reset pin/Temporary sector unprotection	36	DQ11		
13	N.C.	-	Non connection	37	VCC	-	Power supply
14	N.C.	-	Non connection	38	DQ4	I/O	Data inputs/outputs
15	RY/BY	O	Ready/Busy output	39	DQ12		
16	A18	I	Address inputs	40	DQ5		
17	A17			41	DQ13		
18	A7			42	DQ6		
19	A6			43	DQ14		
20	A5			44	DQ7		
21	A4			45	DQ15/A-1	I/O	Data inputs/outputs / Address input
22	A3			46	VSS	-	Ground
23	A2			47	BYTE	I	Selects 8-bit or 16-bit mode
24	A1			48	A16	I	Address input

■ M65773AFP (DVDM ASSY : IC801)

• MPEG2 Decoder IC

● Block Diagram

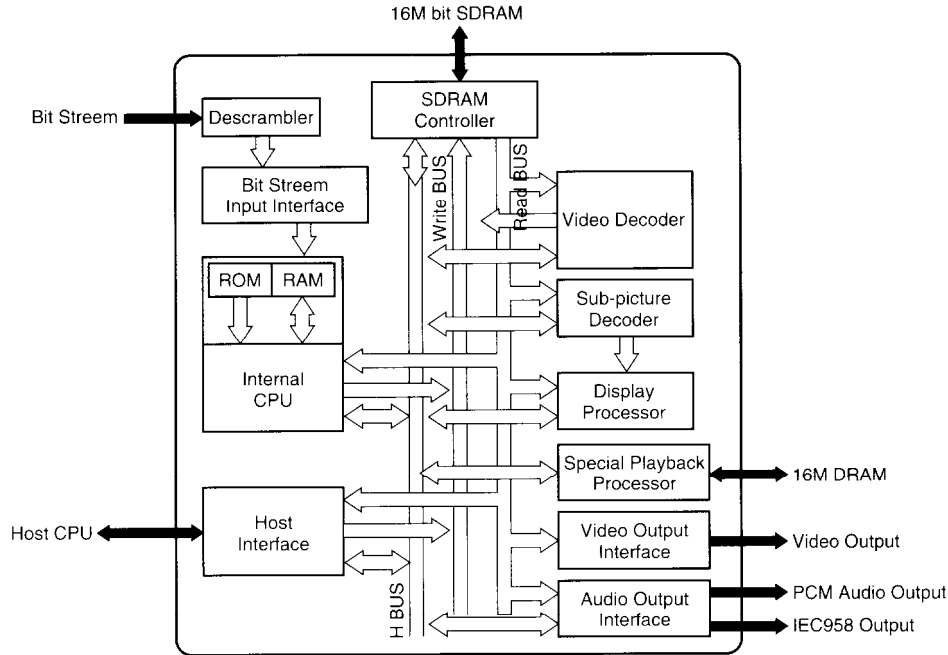

● Pin Function

No.	Pin Name	I/O	Pin Function	No.	Pin Name	I/O	Pin Function		
1	GND	I	Ground	21	5VDD	I	5V power supply		
2	HD0	I/O	Data input and output port	22	HD15	I/O	Data input and output port		
3	HD1			23	CS	I	Chip select signal input		
4	HD2			24	RE	I	Read Enable signal input		
5	HD3			25	WE	I	Write Enable signal input		
6	HD4			26	BHE	I	Byte High Enable signal input		
7	5VDD	I	5V power supply	27	RDY	O	Acknowledge signal which is indicated the finish of data reading or writing via the host bus		
8	VDD	I	Power supply	28	INTR	O	Interrupt request signal against to the external CPU from M65773FP		
9	HD5	I/O	Data input and output port	29	GND	I	Ground		
10	HD6			I	Address input port	30	HA0	I	
11	HD7					31	HA1		
12	HD8					32	HA2		
13	HD9					33	HA3		
14	GND	I	Ground	34	HA4	I	Address input port		
15	HD10	I/O	Data input and output port	35	VDD			I	Power supply
16	HD11			36	5VDD			I	5V power supply
17	HD12			37	HA5			I	
18	HD13			38	HA6				
19	HD14			39	HA7				
20	VDD	I	Power supply	40	HA8				

No.	Pin Name	I/O	Pin Function	No.	Pin Name	I/O	Pin Function
41	HA9	I	Address input port	83	VDD	I	Power supply
42	GND	I	Ground	84	VSYNC	O	Vertical sync. signal output
43	CDMCK	I	Connect to ground	85	HSYNC	O	Horizontal sync. signal output
44	CDLRCK	I	L/R clock input from CDDSP	86	PICSTRT		
45	CDBCK	I	PCM bit clock input from CDDSP	87	MBSTRT		
46	CDDATA	I	Digital audio interface input	88	MBDATA		
47	VDD	I	Power supply	89	GND	I	Ground
48	CDDIN	I	PCM audio data input from CDDSP	90	PWD	O	Phase comparator output for external sync. operation
49	INT2	O	Interrupt request signal against to the external CPU from M65773FP	91	CSYNC	I	Composite SYNC signal input
50	INT3			92	OSDKEY	O	OSD key flag output
51	DREQ	O	DMA request signal for OSD bitmap transfer	93	PXCLK	O	Pixel clock (27MHz free-running clock)
52	DACK	I	DMA acknowledge signal for OSD bitmap transfer	94	VDD	I	Power supply
53	GND	I	Ground	95	PD7	O	Digital pixel data
54	CLKO	O	27MHz clock output	96	PD6		
55	CLKIN	I	System clock input	97	PD5		
56	AVDD1	I	Analog power supply	98	PD4		
57	AGND1	I	Analog ground	99	GND	I	Ground
58	AGND3			100	PD3	O	Digital pixel data
59	AVDD3	I	Analog power supply	101	PD2		
60	CCAP	I	Connect to ground	102	PD1		
61	AGND2	I	Analog ground	103	PD0		
62	AVDD2	I	Analog power supply	104	VDD	I	Power supply
63	ACLKO	-	Open	105	GND	I	Ground
64	ACLKI	I	Audio clock input	106	RESET	I	Hardware reset input
65	HMODE1	I	Setting pin of host interface operating mode	107	TEST0	I	Connect to ground normally
66	GND	I	Ground	108	TEST1		
67	VDD	I	Power supply	109	TEST2		
68	AOD	O	PCM output of audio data	110	VDD	I	Power supply
69	AO2			111	NMD0	I/O	Data transfer line with DRAM
70	AO1			112	NMD15		
71	AO0			113	NMD1		
72	GND	I	Ground	114	NMD14		
73	DOUT1	O	Digital audio interface output	115	GND	I	Ground
74	DOUT0			116	NMD2	I/O	Data transfer line with DRAM
75	SDA	-	Open	117	NMD13		
76	SCL	-	Open	118	NMD3		
77	VDD	I	Power supply	119	NMD12		
78	GND	I	Ground	120	VDD	I	Power supply
79	DACCLK	O	Over-sampling operating clock output	121	NMD4	I/O	Data transfer line with DRAM
80	DOCLK	O	PCM bit clock output	122	NMD11		
81	LRCLK	O	Clock output for discriminating the channel (L/R) of PCM audio data	123	NMD5		
82	HMODE0	I	Setting pin of host interface operating mode	124	NMD10		

No.	Pin Name	I/O	Pin Function	No.	Pin Name	I/O	Pin Function		
125	GND	I	Ground	167	MA5	O	Address line with SDRAM		
126	NMD6	I/O	Data transfer line with DRAM	168	GND	I	Ground		
127	NMD9			O	Address line with SDRAM				
128	NMD7								
129	NMD8								
130	VDD	I	Power supply	172	MA7				
131	NCAS0	O	CAS (Column Address Strobe) control line of DRAM	173	VDD	I	Power supply		
132	NWE	O	WE control line of DRAM	174	MA10	O	Address line with SDRAM		
133	NCAS1	O	CAS (Column Address Strobe) control line of DRAM	175	MA8				
134	NRAS	O	RAS (Row Address Strobe) control line of DRAM	176	MA11				
135	GND	I	Ground	177	MA9				
136	NMA9	O	Address line with DRAM	178	GND	I	Ground		
137	NMA8			179	DCS	O	Chip select of SDRAM		
138	VDD	I	Power supply	180	RAS	O	RAS (Row Address Strobe) control line of SDRAM		
139	NMA0	O	Address line with DRAM	181	CAS	O	CAS (Column Address Strobe) control line of SDRAM		
140	NMA7			182	VDD	I	Power supply		
141	NMA1			183	MCLK	O	Operation clock of SDRAM		
142	NMA6			184	GND	I	Ground		
143	GND	I	Ground	185	DWE	O	WE control line of SDRAM		
144	NMA2	O	Address line with DRAM	186	DQMU	O	DQM control line of SDRAM Use for mask of upper byte output.		
145	NMA5			187	DQML	O	DQM control line of SDRAM Use for mask of lower byte output.		
146	NMA3			188	VDD	I	Power supply		
147	NMA4			I/O	Data transfer line with SDRAM				
148	VDD	189	MD7						
149	BD7	I	Bit stream input port	190	MD8				
150	BD6	I		191	MD6				
151	GND	I	Ground	192	MD9				
152	BD5	I	Bit stream input port	193	GND	I	Ground		
153	BD4			I/O	Data transfer line with SDRAM				
154	BD3					194	MD5		
155	BD2					195	MD10		
156	VDD	I	Power supply	196	MD4				
157	GND	I	Ground	197	MD11				
158	BD1	I	Bit stream input port	198	VDD	I	Power supply		
159	BD0			199	MD3	I/O	Data transfer line with SDRAM		
160	BCLK	I	Strobe signal (clock) of BD port	200	MD12				
161	BDEN	I	Indicates the effective or invalid data which is sampled from BD port	201	MD2				
162	BDREQ	O	Output permission signal against to the device (channel decoder) which connecting to BD port	202	MD13				
163	VDD	I	Power supply	203	GND	I	Ground		
164	MA3	O	Address line with SDRAM	204	MD1	I/O	Data transfer line with SDRAM		
165	MA4			205	MD14				
166	MA2			206	MD0				
				207	MD15				
				208	VDD	I	Power supply		

■ PM0023AF (VQEB ASSY : IC101)

• VQE4 IC

• Block Diagram

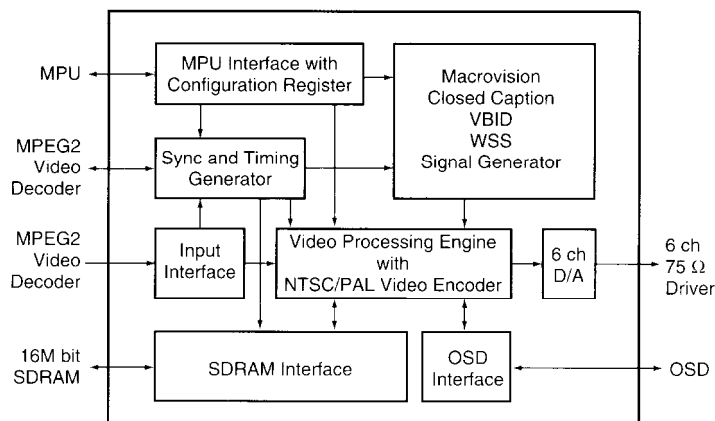

• Pin Function

No.	Pin Name	I/O	Pin Function
1	GND_00	-	Ground Connect to reference voltage (0V).
2	CLAMP	O	Clamp pulse output
3	RMA0	I	Register monitor address input
4	RMA1		
5	RMA2		
6	RMA3		
7	RMA4		
8	RMA5		
9	DOC0	I	Output data control input
10	DOC1		
11	VDD_00	-	Power supply Connect to 3.3V.
12	GND_01	-	Ground Connect to reference voltage (0V).
13	CSB	I	Chip select input for microcomputer interface L: select Schmitt input
14	SDATA	I	Serial data input for microcomputer interface Schmitt input
15	SCLK	I	Serial clock input for microcomputer interface Lead in SDATA at rising edge. Schmitt input
16	SRN	I	System reset input L: reset Schmitt input
17	TEST	I	Test mode control input Connect to GND.
18	VCC_S0	-	Power supply Connect to 3.3V.
19	GND_S0	-	Ground Connect to reference voltage (0V).
20	XI	I	Connect a crystal resonator (27MHz) Connect to VCC (+3.3V) when using CLK (pin 23).
21	XO	O	Connect a crystal resonator (27MHz) Set to open when using CLK (pin 23).
22	GND_02	-	Ground Connect to reference voltage (0V).
23	CLKI	I	External clock (27MHz) input
24	VDD_01	-	Power supply Connect to 3.3V.

No.	Pin Name	I/O	Pin Function
25	VI0	I	(LSB) Video data input Input 8-bit parallel signal of CCIR-601 or CCIR-656 systems.
26	VI1		
27	VI2		
28	VI3		
29	VI4		
30	VI5		
31	VI6		
32	VI7		
33	GND_03	-	Ground Connect to reference voltage (0V).
34	NHS	I/O	Horizontal sync. signal input Outputs at Master mode and inputs at Slave mode (set with the register). Negative polarity
35	NVS	I/O	Vertical sync. signal input Outputs at Master mode and inputs at Slave mode (set with the register). Negative polarity
36	VDD_02	-	Power supply Connect to 3.3V.
37	DOC2	I	Output data control input
38	GND_04	-	Ground Connect to reference voltage (0V).
39	MD00	I/O	(LSB) Data input and output for external memory with pull-up
40	MD01		
41	MD02		
42	MD03		
43	VDD_03	-	Power supply Connect to 3.3V.
44	GND_05	-	Ground Connect to reference voltage (0V).
45	MD04	I/O	Data input and output for external memory with pull-up
46	MD05		
47	MD06		
48	MD07		
49	VDD_04	-	Power supply Connect to 3.3V.
50	MD15	I/O	Data input and output for external memory with pull-up (MSB)
51	MD14	I/O	Data input and output for external memory with pull-up
52	MD13		
53	MD12		
54	VCC_S1	-	Power supply Connect to 3.3V.
55	GND_S1	-	Ground Connect to reference voltage (0V).
56	MD11	I/O	Data input and output for external memory with pull-up
57	MD10		
58	MD09		
59	MD08		
60	GND_06	-	Ground Connect to reference voltage (0V).
61	MCLK	O	Clock output for external memory
62	MA09	O	Address output for external memory
63	MA08		
64	MA07		
65	MA06		
66	VDD_05	-	Power supply Connect to 3.3V.
67	GND_07	-	Ground Connect to reference voltage (0V).
68	MA05	O	Address output for external memory
69	MA04		
70	MWEB	O	Writing control output for external memory
71	MCASB	O	CAS output for external memory
72	MRASB	O	RAS output for external memory
73	MA11	O	Address output for external memory (MSB)
74	MA10	O	Address output for external memory
75	MA00	O	Address output for external memory (LSB)

No.	Pin Name	I/O	Pin Function
76	VDD_06	-	Power supply Connect to 3.3V.
77	GND_08	-	Ground Connect to reference voltage (0V).
78	MA01	O	Address output for external memory
79	MA02		
80	MA03		
81	OSDHSY	O	Horizontal sync. signal output for external OSD Negative polarity
82	OSVSY	O	Vertical sync. signal output for external OSD Negative polarity
83	VDD_07	-	Power supply Connect to 3.3V.
84	GND_09	-	Ground Connect to reference voltage (0V).
85	OSDCLK	O	Clock output for external OSD
86	GND_10	-	Ground Connect to reference voltage (0V).
87	CTA2	I	OSD data input
88	CTA1		
89	CTA0		
90	VCC_S2	-	Power supply Connect to 3.3V.
91	GND_S2	-	Ground Connect to reference voltage (0V).
92	BLD1	I	OSD blend control input
93	BLD0		
94	SCAN_T	I	Control input for scan test Connect to 3.3V.
95	SCAN_W		
96	DO0	O	Data output
97	DO1		
98	DO2		
99	DO3		
100	DO4		
101	DO5		
102	DO6		
103	DO7		
104	DO8		
105	DO9		
106	RMO0	O	Register monitor output
107	RMO1		
108	VDD_08	-	Power supply Connect to 3.3V.
109	RMO2	O	Register monitor output
110	RMO3		
111	VDD_09	-	Power supply Connect to 3.3V.
112	GND_11	-	Ground Connect to reference voltage (0V).
113	GND_AGB0	A	Ground for Guard band Connect to reference voltage (0V).
114	VDDDA_A0	A	Power supply for A0 channel DAC Connect to 3.3V.
115	DAO_A0	A	DAC output of A0 channel Current output Connect a 330Ω resistor to GND.
116	GNDDA_A0	A	DAC ground of A0 channel Connect to reference voltage (0V).
117	DAO_A1	A	DAC output of A1 channel Current output Connect a 330Ω resistor to GND.
118	GNDDA_A1	A	DAC ground of A1 channel Connect to reference voltage (0V).
119	VDDDA_A1	A	Power supply for A1 channel DAC Connect to 3.3V.
120	CBU_A	A	Connect a phase compensation capacitor for Group_A_DAC Connect a 0.1μF capacitor to GND.

No.	Pin Name	I/O	Pin Function
121	REXT_A	A	Connect a reference resistor for Group_A_DAC Connect a 3.1 (3.0) kΩ resistor to GND>
122	CBL_A	A	Connect a by-pass capacitor for Group_A_DAC Connect a 0.1μF capacitor to GND.
123	VDDDA_A2	A	Power supply for A2 channel DAC Connect to 3.3V.
124	GNDDA_A2	A	DAC ground of A2 channel Connect to reference voltage (0V).
125	DAO_A2	A	DAC output of A2 channel Current output Connect a 330Ω resistor to GND.
126	VDDDA_B0	A	Power supply for B0 channel DAC Connect to 3.3V.
127	GNDDA_B0	A	DAC ground of B0 channel Connect to reference voltage (0V).
128	DAO_B0	A	DAC output of B0 channel Current output Connect a 330Ω resistor to GND.
129	GNDDA_B1	A	DAC ground of B1 channel Connect to reference voltage (0V).
130	DAO_B1	A	DAC output of B1 channel Current output Connect a 330Ω resistor to GND.
131	VDDDA_B1	A	Power supply for B1 channel DAC Connect to 3.3V.
132	CMU_B	A	Connect a phase compensation capacitor for Group_B_DAC Connect a 0.1μF capacitor to GND.
133	REXT_B	A	Connect a reference resistor for Group_B_DAC Connect a 3.1 (3.0) kΩ resistor to GND>
134	CBL_B	A	Connect a by-pass capacitor for Group_B_DAC Connect a 0.1μF capacitor to GND.
135	GNDDA_B2	A	DAC ground of B2 channel Connect to reference voltage (0V).
136	DAO_B2	A	DAC output of B2 channel Current output Connect a 330Ω resistor to GND.
137	VDDDA_B2	A	Power supply for B2 channel DAC Connect to 3.3V.
138	GND_AGB1	A	Ground for Guard band Connect to reference voltage (0V).
139	RMO4	O	Register monitor output
140	RMO5		
141	RMO6		
142	RMO7		
143	VDD_10	-	Power supply Connect to 3.3V.
144	CLKO	O	Clock (27MHz) output

■ CY2081SL-655 (DVDM ASSY : IC21)

• Clock Generate IC

• Block Diagram

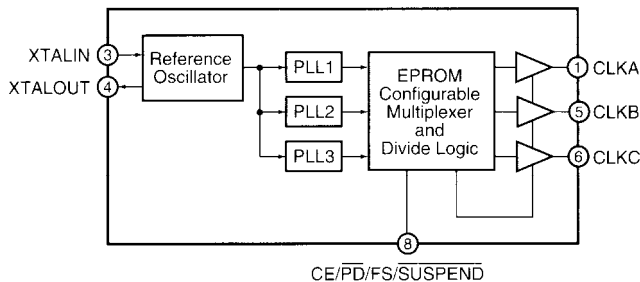

• Pin Function

No.	Pin Name	Pin Function
1	CLKA	Configurable clock output
2	GND	Ground
3	XTALIN	Reference crystal input of external reference clock input
4	XTALOUT	Reference crystal feedback
5	CLKB	Configurable clock output
6	CLKC	Configurable clock output
7	VDD	Voltage supply
8	OE/PD/FS/SUSPEND	Output control pin; either active-HIGH output enable, active-LOW power down, CLKA frequency select, or active-LOW suspend input

7.2.2 DISPLAY

■ VAW1052 (FLKY ASSY : V701)

• FL Display

• Pin Assignment

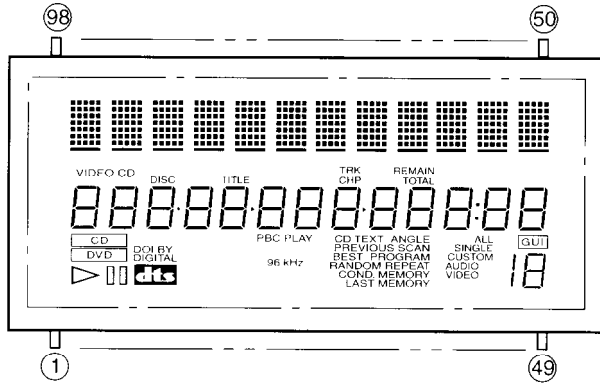

• Pin Connection

Pin No.	98	97	96	95	94	93	92	91	90	89	88	87	86
Connection	F1	F1	F1	F1	NP	NP	13G	12G	11G	10G	9G	8G	7G
Pin No.	85	84	83	82	81	80	79	78	77	76	75	74	73
Connection	6G	5G	4G	3G	2G	1G	NX	NX	NX	NX	NX	NX	NX
Pin No.	72	71	70	69	68	67	66	65	64	63	62	61	60
Connection	NX	NX	NX	P37	P36	P35	P34	P33	P32	P31	P30	P29	P28
Pin No.	59	58	57	56	55	54	53	52	51	50	49	48	47
Connection	P27	P26	P25	P24	NP	NP	F2	F2	F2	F2	F2	F2	F2
Pin No.	46	45	44	43	42	41	40	39	38	37	36	35	34
Connection	F2	NP	NP	P23	P22	P21	P20	P19	P18	P17	P16	P15	P14
Pin No.	33	32	31	30	29	28	27	26	25	24	23	22	21
Connection	P13	P12	P11	NX	NX	NX	NX	NX	NX	NX	NX	NX	NX
Pin No.	20	19	18	17	16	15	14	13	12	11	10	9	8
Connection	P10	P9	P8	P7	P6	P5	P4	P3	P2	P1	16G	15G	14G
Pin No.	7	6	5	4	3	2	1						
Connection	IC	NP	NP	F1	F1	F1	F1						

Note (1) F1, F2 : Filament (4) DL : Datum Line
 (2) NP : No pin (5) 1G to 16G : Grid
 (3) NX : No extend pin (6) IC : Internal connection

• Grid Assignment

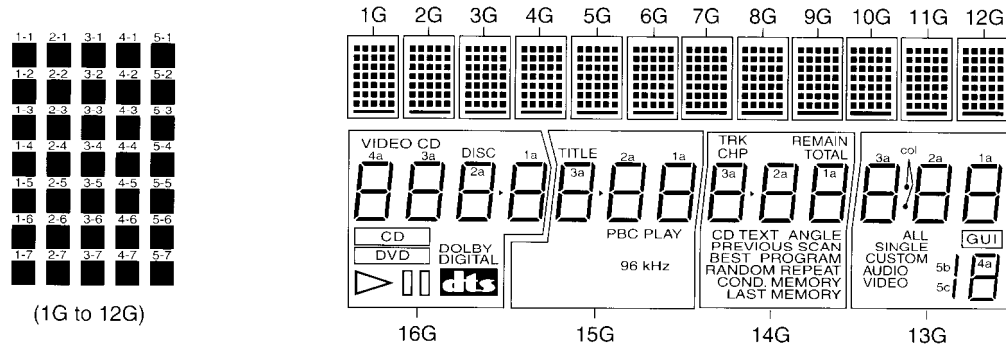

• Anode Connection

	1G to 12G	13G	14G	15G	16G
P1	1-1	VIDEO	LAST MEMORY	DOWN MIX	
P2	2-1	AUDIO	COND. MEMORY	LFE	
P3	3-1	CUSTOM	REPEAT		
P4	4-1	SINGLE	RANDOM	V-PART	DVD
P5	5-1	5d	PROGRAM	RS	CD
P6	1-2	3d	BEST	S	4d
P7	2-2	3e	SCAN	LS	4e
P8	3-2	3c	PREVIOUS	R	4c
P9	4-2	3g	ANGLE	C	4g
P10	5-2	3f	TEXT	L	4f
P11	1-3	3b	CD	96kHz	4b
P12	2-3	3a	REMAIN	192kHz	4a
P13	3-3	col	TOTAL	PBC PLAY	DOLBY DIGITAL
P14	4-3	2d	3d	3d	3d
P15	5-3	2e	3e	3e	3e
P16	1-4	2c	3c	3c	3c
P17	2-4	2g	3g	3g	3g
P18	3-4	2f	3f	3f	3f

	1G to 12G	13G	14G	15G	16G
P19	4-4	2b	3b	3b	3b
P20	5-4	2a	3a	3a	3a
P21	1-5	5b, 5c			VIDEO CD
P22	2-5	1d	2d	2d	2d
P23	3-5	1e	2e	2e	2e
P24	4-5	1c	2c	2c	2c
P25	5-5	1g	2g	2g	2g
P26	1-6	1f	2f	2f	2f
P27	2-6	1b	2b	2b	2b
P28	3-6	1a	2a	2a	2a
P29	4-6	GUI	CHP	TITLE	
P30	5-6	4d	1d	1d	1d
P31	1-7	4e	1e	1e	1e
P32	2-7	4c	1c	1c	1c
P33	3-7	4g	1g	1g	1g
P34	4-7	4f	1f	1f	1f
P35	5-7	4b	1b	1b	1b
P36	—	4a	1a	1a	1a
P37	—	ALL	TRK	GRP	DISC

8.2 SPECIFICATIONS

General

System	File-type DVD system and Compact Disc digital audio system
Power requirements	AC 120 V, 60 Hz
Power consumption	21 W
Power consumption in standby mode	less than 0.9 W
Weight	7.9 kg (17.4 lbs.)
Dimensions	435 (W) x 441 (D) x 193 (H) mm (17 ³ / ₁₆ (W) x 17 ³ / ₈ (D) x 7 ⁵ / ₈ (H) in.) (Not including protruding cables, etc.)
Operating temperature	+5°C to +35°C (+36°F to +96°F)
Operating humidity	5% to 85% (no condensation)

S-Video input/output

Y (luminance) - Output level	1 Vp-p (75 Ω)
C (color) - Output level	286 mVp-p (75 Ω)
Jacks	S-VIDEO jack

Video input/output

Output level	1 Vp-p (75 Ω)
Jacks	RCA jack

Component video output

(Y, P _B , P _R)	
Output level	Y: 1.0 Vp-p (75 Ω) P _B , P _R : 0.7 Vp-p (75 Ω)
Jacks	RCA jack

Audio input/output

Output level	
During audio output	200 mVrms (1 kHz, -20 dB)
Number of channels	2
Jacks	RCA jack

Digital audio characteristics

Frequency response	4 Hz to 44 kHz (DVD fs: 96 kHz)
S/N ratio	more than 115 dB
Dynamic range	more than 102 dB
Total harmonic distortion	0.002%
Wow and flutter	Limit of measurement (±0.001% W. PEAK) or lower

Digital output

Optical digital output	Optical digital jack
Coaxial digital input/output	RCA jack

Control jacks

MASTER-SLAVE	Stereo minijack (3.5 φ)
--------------------	-------------------------

Other jacks

KEYBOARD/MOUSE jack	6-pin DIN connection jack
---------------------------	---------------------------

Accessories

Remote control unit	1
AA (R6P) dry cell batteries	2
Audio cord	1
Video cord	1
Master-Slave control cord	1
AC cord	1
Operating Instructions	1
Warranty Card	1

Note

The specifications and design of this product are subject to change without notice, due to improvement.

- Manufactured under license from Dolby Laboratories. "Dolby" and the double-D symbol are trademarks of Dolby Laboratories. Confidential unpublished works. © 1992-1997 Dolby Laboratories. All rights reserved.
- "DTS" is a trademark of Digital Theater Systems, Inc. Manufactured under license from Digital Theater Systems, Inc.

● Accessories

Audio Cord (L = 1.5m) : VDE1033

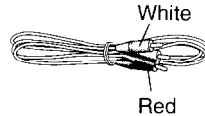

Video Cord (L = 1.5m) : VDE1034

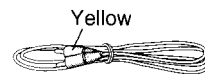

Master-Slave Control Cord (L = 0.75m) : RDE i023

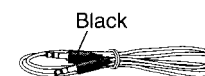

AC Cord : 253297KAW

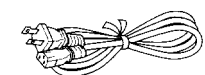

Remote Control Unit : VXX2708

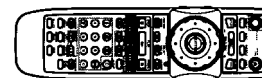

Dry Cell Battery (R6P, AA)

