

SPECIFICATIONS

AMPLIFIER SECTION

Power Output (FTC)

All channels 40 watts per channel min.
RMS. into 6 ohms two channel driven,
1,000 Hz with no more than 5 % total
harmonic distortion.

Continuous power output (DIN)

All channels 30 watts per channel min.
RMS. into 6 ohms two channel driven, 1,000 Hz

Continuous Power output (EIAJ)

All channel 45 watts per channel min.
RMS. into 6 ohms two channel driven, 1,000 Hz

Dynamic Power 6 ohms: 42 W (L/R)

8 ohms: 35 W (L/R)

Total Harmonic Distortion 5 % at rated power

0.2 % at 1 watt output

IM Distortion 5 % at rated power

0.2 % at 1 watt output

Damping Factor 40 at 8 ohms

Input Sensitivity and Impedance

VIDEO 1 DIGITAL INPUT (OPT) -21 to -15 dBm
VIDEO 2 DIGITAL INPUT (COAX) 0.5 Vp-p, 75 ohms
LINE (VIDEO 1, VIDEO 2/CDR/PC, TV/LINE, TAPE/MD/HD)
200 mV/50 kohms

Composite (VIDEO 1, VIDEO 2/CDR/PC) 1 Vp-p, 75 ohms
S-VIDEO (VIDEO 1, VIDEO 2/CDR/PC) Y: 1 Vp-p, 75 ohms
C: 0.28 Vp-p, 75 ohms

Output Level and Impedance

DIGITAL OUTPUT (OPT) -21 to -15 dBm

REC OUT (TAPE/MD/HD, VIDEO 2/CDR/PC) 200 mV, 2.2 kohms

PRE OUT (SUBWOOFER) 1 V, 470 ohms

Composite (MON OUT, VIDEO 1) 1 Vp-p, 75 ohms

S-VIDEO (MON OUT, VIDEO 1) Y: 1 Vp-p, 75 ohms

C: 0.28 Vp-p, 75 ohms

COMPONENT VIDEO OUTPUT Y: 1.0 Vp-p, 75 ohms

PB/PR: 0.7 Vp-p, 75 ohms

Frequency Response

20 to 30,000 Hz : +/- 0.8 dB

Acoustic Control

1: +9 dB at 120 Hz

2: +9 dB at 120 Hz

+6 dB at 10,000 Hz

Signal-to-noise Ratio

100 dB (0.5 V INPUT LINE)

Muting

-50 dB

DVD SECTION

Signal readout system

Optical non-contact

Linear velocity

3.49 m/s (Single Layer)

3.84 m/s (Dual Layer)

Error correction system

Reed Solomon Product Code

Signal system NTSC

Regional restriction code

1

Laser

Semiconductor laser, wavelength 650 nm

Frequency response

10 Hz to 44 kHz (96 kHz)

Signal-to-noise ratio (digital audio)

More than 100 dB

Audio dynamic range (digital audio)

More than 93 dB

Harmonic distortion (digital audio)

Less than 0.025%

Wow and flutter

Below threshold of measurability

Operating conditions

Temperature: 5°C to 35°C (41°F to 95°F),

Operation status: Horizontal

TUNER SECTION

Tuning Range

FM: 87.50 to 108.00 MHz (50 kHz steps)

AM: 530 to 1710 kHz (10 kHz steps)

Usable Sensitivity

FM: Mono 11.2 dBf, 1.0 μ V (75 ohms IHF)
0.9 μ V (75 ohms DIN)

Stereo 17.2 dBf, 2.0 μ V (75 ohms IHF)
23 μ V (75 ohms DIN)

AM: 30 μ V

50 dB Quieting Sensitivity

FM: Mono 17.2 dBf, 2.0 μ V (75 ohms)

Stereo 37.2 dBf, 20.0 μ V (75 ohms)

Capture Ratio

FM: 2.0 dB

Image Rejection Ratio

FM: 40 dB AM: 40 dB

IF Rejection Ratio

FM: 90 dB AM: 40 dB

Signal-to-noise Ratio

FM: Mono 73 dB, IHF

Stereo 67 dB, IHF

AM: 40 dB

Alternate Channel Att. (+/- 400 kHz)

FM: Mono 55 dB, IHF

Selectivity FM: 50 dB, DIN 55dB, IHF

AM Suppression Ratio

FM: 50 dB

Harmonic Distortion

FM: Mono 0.2 %

Stereo 0.3 %

AM: 0.7 %

Frequency response

FM: 30 to 15,000 Hz (+/- 1.0 dB)

Stereo Separation

FM: 45 dB at 1,000 Hz

30 dB at 100 to 10,000 Hz

Stereo Threshold

FM: 17.2 dBf, 20 μ V (75 ohms)

GENERAL

Power Supply Rating and Power Consumption

AC 120 V, 60Hz 2.0 A

Dimensions (W x H x D)

435 x 101 x 428 mm (171/8 x 4 x 1613/16 ins.)

Weight

8.8 kg (19.4 lb.)

Specifications and features are subject to change without notice.

PANEL VIEWS-1

FRONT PANEL

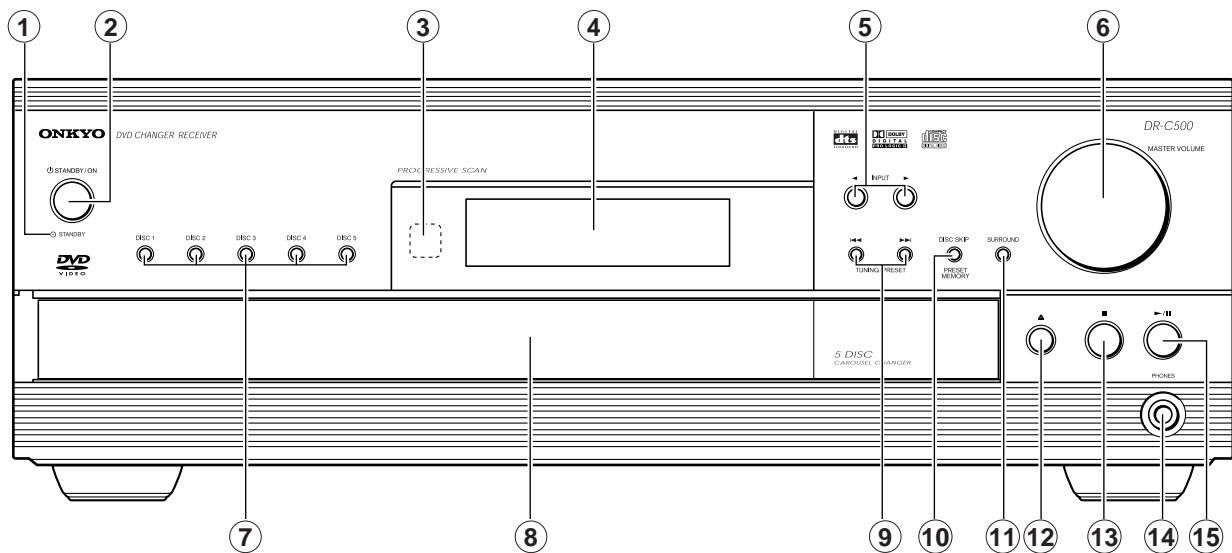

- ① **STANDBY indicator**
- ② **STANDBY/ON button**
When STANDBY/ON button is pressed to ON, the DVD Changer Receiver turns on. The STANDBY indicator turns off and the display lights up. Pressing the button again returns the DVD Changer Receiver to the standby state. This state turns off the display and disables control functions.
- ③ **Remote control sensor**
Point the remote controller toward the remote control sensor to operate the DVD Changer Receiver.
- ④ **Display**
- ⑤ **INPUT ◀▶ buttons**
Press to select the input source.
- ⑥ **MASTER VOLUME dial**
The MASTER VOLUME dial is used to control the volume level.
- ⑦ **DISC 1, DISC 2, DISC 3, DISC 4, DISC 5 buttons**
Press to select a disc in the changer.
- ⑧ **Disc tray**
When loading a disc, place it on the disc tray with its label facing up.
- ⑨ **TUNING/PRESET ◀◀/▶▶ buttons**
When playing discs, press to skip back or forward to consecutive chapters/tracks. When listening to the radio, press to change the tuner frequency or select preset stations.
- ⑩ **PRESET MEMORY/DISC SKIP button**
When listening to the radio, press to assign the radio station that is currently tuned in to a preset channel or delete a previously preset station. When playing discs, press to select a disc. When the DISC SKIP button is pressed while the Disc tray is open, the tray simply rotates.
- ⑪ **SURROUND button**
Press to select a surround mode.
- ⑫ **▲ button**
Press to open and close the disc tray.
- ⑬ **■ button**
Press to stop playback. Pressing once enables playback to resume from a point shortly before the location where it was stopped. Pressing twice causes the disc to return to the beginning of the disc when playback starts again.
- ⑭ **PHONES jack**
This is a standard stereo jack for connecting stereo headphones.
- ⑮ **▶ / || button**
Press to start or pause playback.

PANEL VIEWS-2

DISPLAY

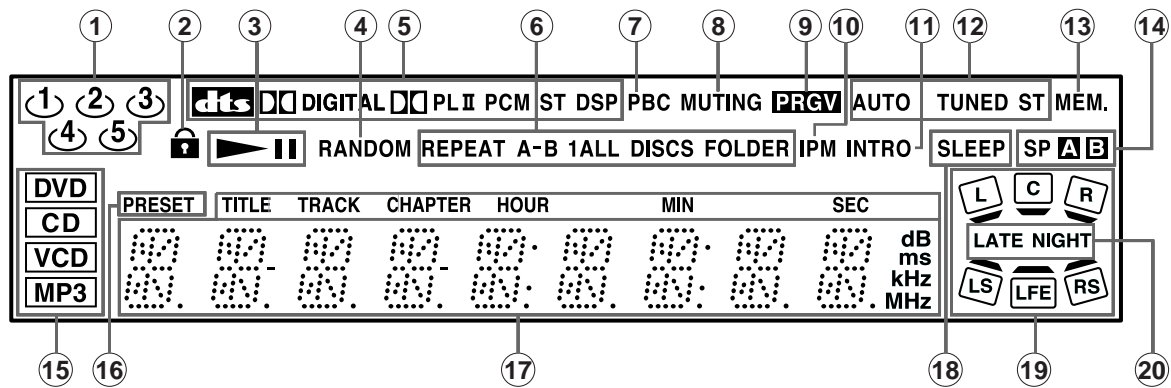

- ① **Disc number indicators**
Indicate the presence of a disc.
- ② **Parental Lock indicator**
Illuminates in parental lock mode.
- ③ **▶, || indicators**
Illuminate in play or pause mode.
- ④ **RANDOM indicator**
Illuminates during random playback.
- ⑤ **Source/Listening mode indicators**
One of the source indicators lights to show the format of the current source. In addition, one of the listening mode indicators lights according to the current listening mode.
- ⑥ **REPEAT indicators**
Illuminate during repeat playback. REPEAT indicator also illuminates during A-B repeat playback.
- ⑦ **PBC indicator**
Illuminates when PBC is on for Video CD.
- ⑧ **MUTING indicator**
Flashes when the mute function is active.
- ⑨ **PRGV indicator**
Illuminates when the DVD Changer Receiver is set to progressivescan video.
- ⑩ **IPM (Intelligent Power Management) indicator**
Lights up when the IPM function is active.
- ⑪ **INTRO indicator**
Lights up during intro-scan playback.
- ⑫ **AUTO, TUNED, ST indicators**
Illuminate to indicate the reception mode.
- ⑬ **MEM. indicator**
Illuminates when the MEM button is pressed in the radio station preset operation and during DVD memory play.
- ⑭ **Speaker indicators**
Illuminate to indicate the selected speakers.
- ⑮ **Inserted disc indicators**
Illuminate to indicate the type of disc that is playing currently.
- ⑯ **PRESET indicator**
Illuminates when tuned to a preset station.
- ⑰ **Multipurpose display**
Indicates operating status, messages, etc.
- ⑱ **SLEEP indicator**
Lights up when the sleep timer is active.
- ⑲ **Speaker setup indicators**
Indicate the speaker configuration. Light to show speaker positions, input and output signals for each channel.
- ⑳ **LATE NIGHT indicator**
Illuminates when the unit is in Late Night mode.

PANEL VIEWS-3

REAR PANEL

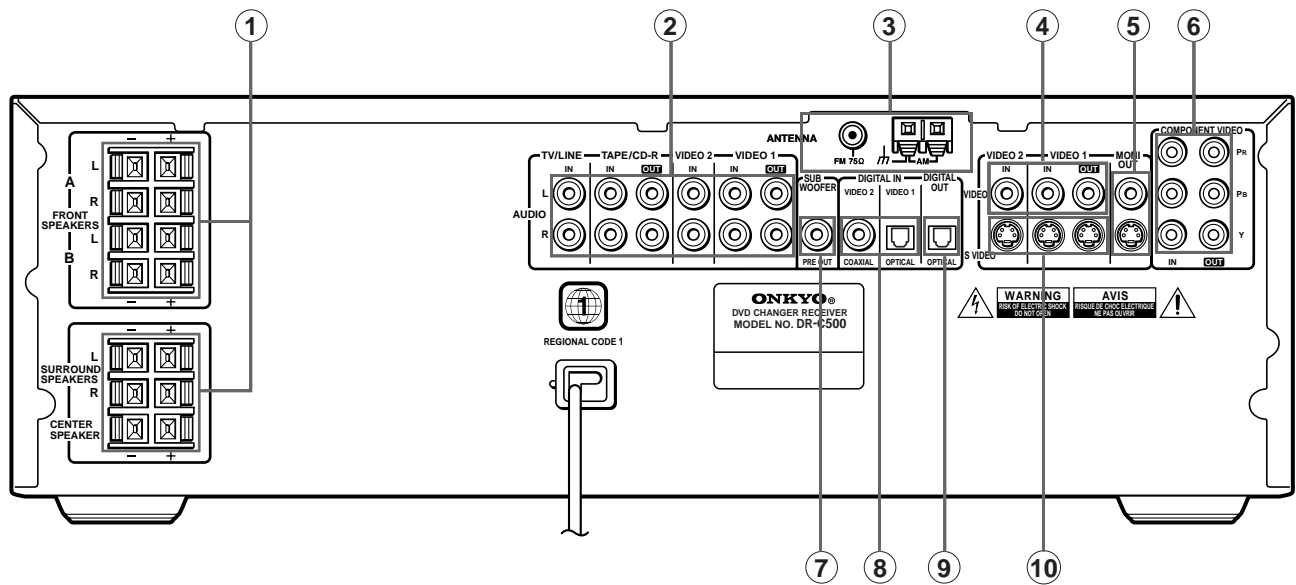

① FRONT SPEAKERS A/B, SURROUND SPEAKERS and CENTER SPEAKER terminals

FRONT SPEAKERS: system: To enjoy home theater sound. Speaker terminals are provided for the front left, front right, center, surround left and surround right speakers.

FRONT SPEAKERS: system: To enjoy stereo sound. Speaker terminals are provided for the front left and front right.

② AUDIO (TV/LINE IN / TAPE/CD-R IN/OUT / VIDEO 1 IN/OUT / VIDEO 2 IN) jacks

These are the analog audio inputs and outputs. There are 4 audio inputs and 2 audio outputs. The audio inputs and outputs require RCA type connectors.

When connecting a VCR or other video component, make sure you connect the audio and video leads to the same set of jacks (i.e., both to VIDEO 1).

③ ANTENNA terminals

These terminals are for connecting the FM antenna and AM antenna.

④ VIDEO (VIDEO 1 IN/OUT / VIDEO 2 IN) jacks

There are 2 video inputs and 1 output. Connect LD players, VCRs or other video components to the video inputs. The video output channel can be used to be connected to a video tape recorder for making recordings.

⑤ MONI OUT jacks

The monitor output includes both RCA type and S video configurations. This output is for connecting a television monitor or projector.

⑥ COMPONENT VIDEO IN/OUT jacks

If your TV has component inputs, you can connect a component video cable to the component input of your TV and to the COMPONENT VIDEO OUT jack of your DVD Changer Receiver for ideal video quality.

If a DVD player or other device has component video out jacks, you can directly input a component signal to the COMPONENT VIDEO IN jack.

The component video cable only carries the video signal; remember to connect the left and right audio cables.

If you connect a TV that is compatible with a Progressive scan signal, you can enjoy both Interlaced and Progressive scan.

⑦ SUB WOOFER PRE OUT jack [16]

This terminal is for connecting an active subwoofer.

⑧ DIGITAL IN (VIDEO 1 OPTICAL, VIDEO 2 COAXIAL) jacks

These are the digital audio inputs. There is 1 digital input with an optical jack and 1 with a coaxial jack. The inputs accept digital audio signals from MD players, hard disk recorders, CD players, or other digital source component.

⑨ DIGITAL OUT (OPTICAL) jack

This jack is for connecting an MD recorder, CD recorder, hard disk recorder or other component with optical fiber cable.

⑩ S VIDEO (VIDEO 1 IN/OUT / VIDEO 2 IN) jacks

There are 2 S Video inputs and 1 output. Connect LD players, VCRs or other video components to the video inputs. The S Video output channel can be used to be connected to video tape recorder for making recordings. The S-Video cable only carries the video signal. Remember to connect the left and right audio cables.

EXPLODED VIEWS-1 FRONT PART

[NOTES]

Refer to PC CONNECTION DIAGRAM
about REF.NO. of the wires and the flat cables.

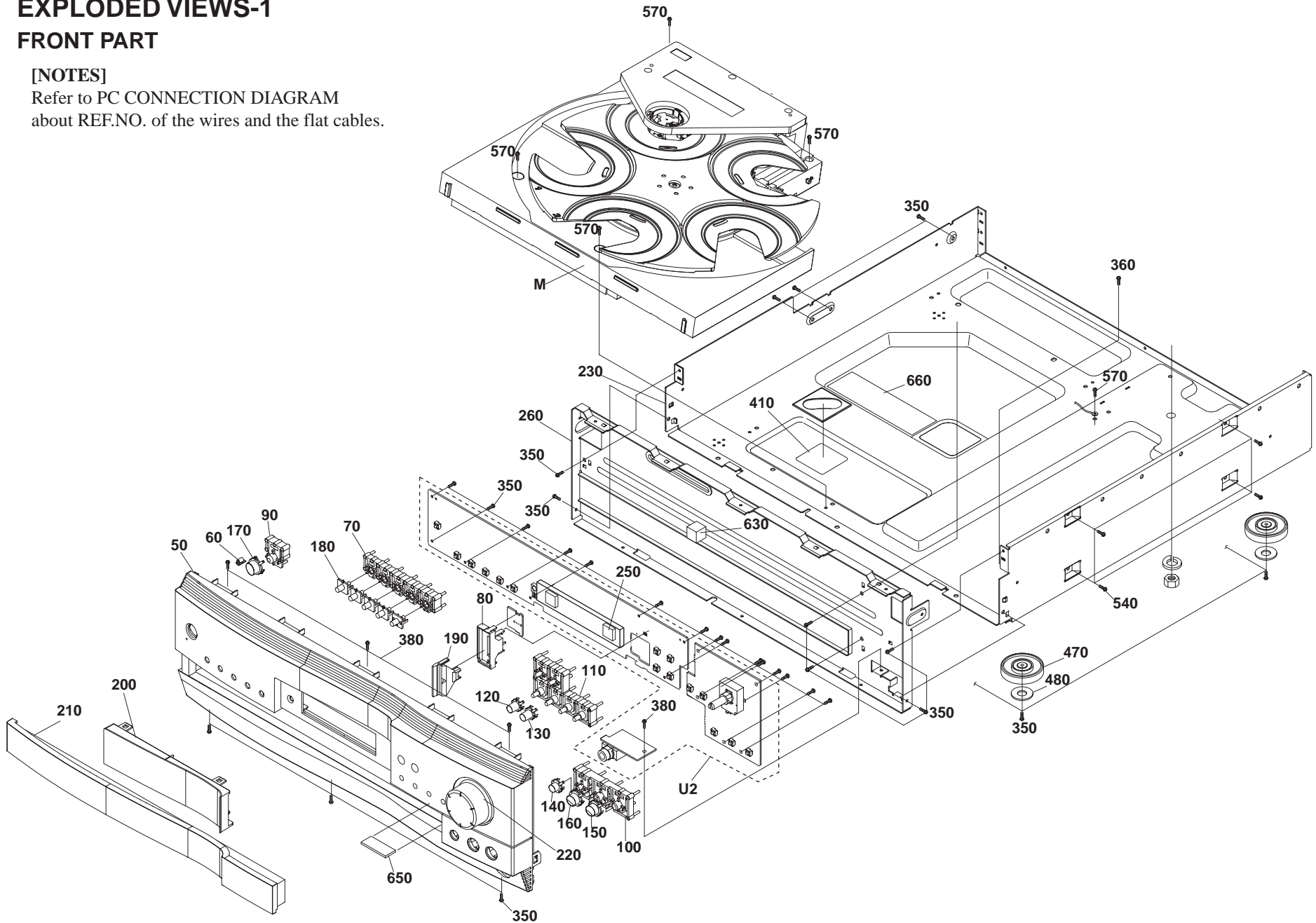

EXPLODED VIEWS-2

REAR PART

[NOTES]

Refer to PC CONNECTION DIAGRAM
about REF.NO. of the wires and the flat cables.

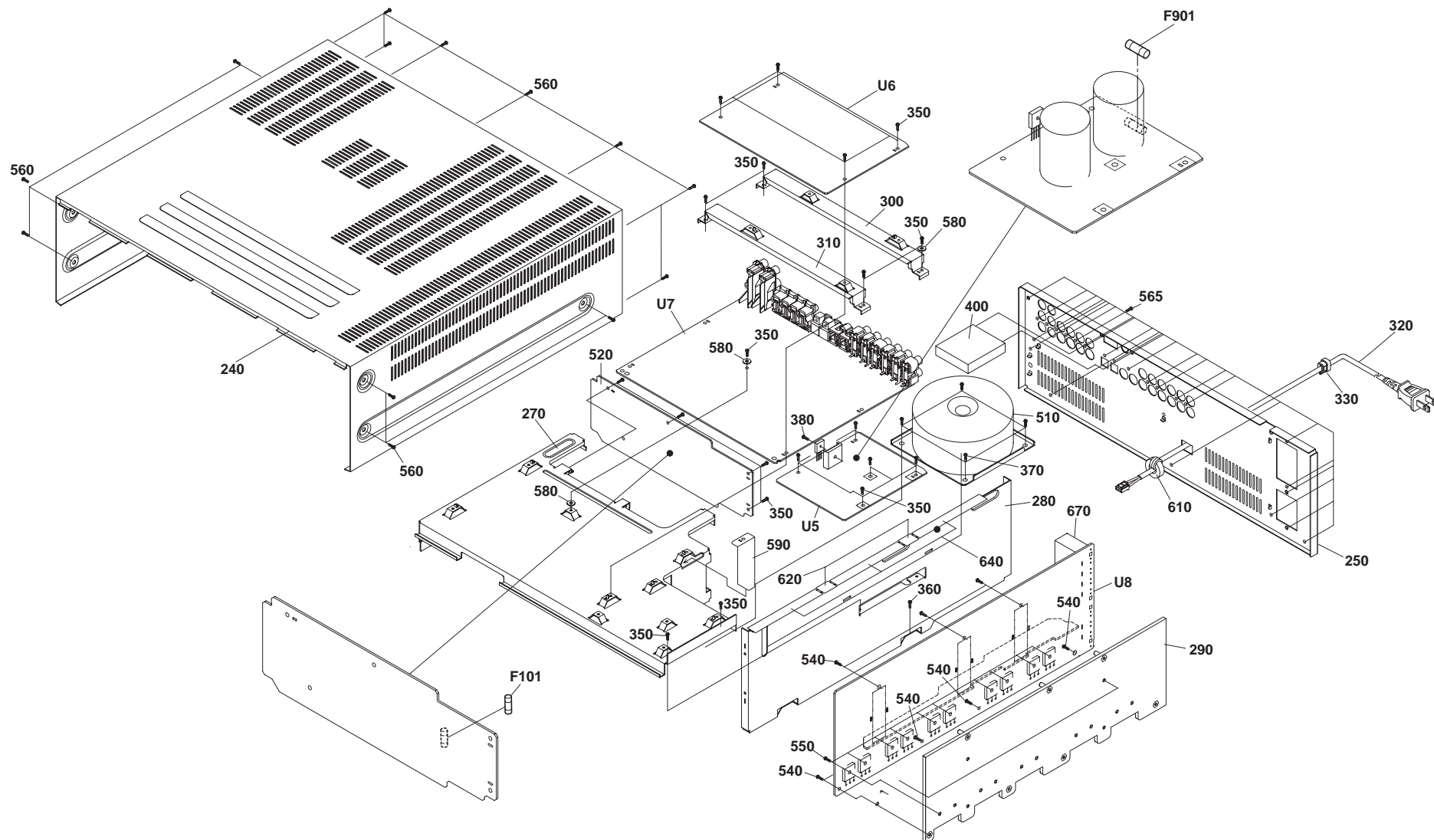

EXPLODED VIEWS OF DVD MECHANISM-1 DWG ASY CAROUSEL TC5E

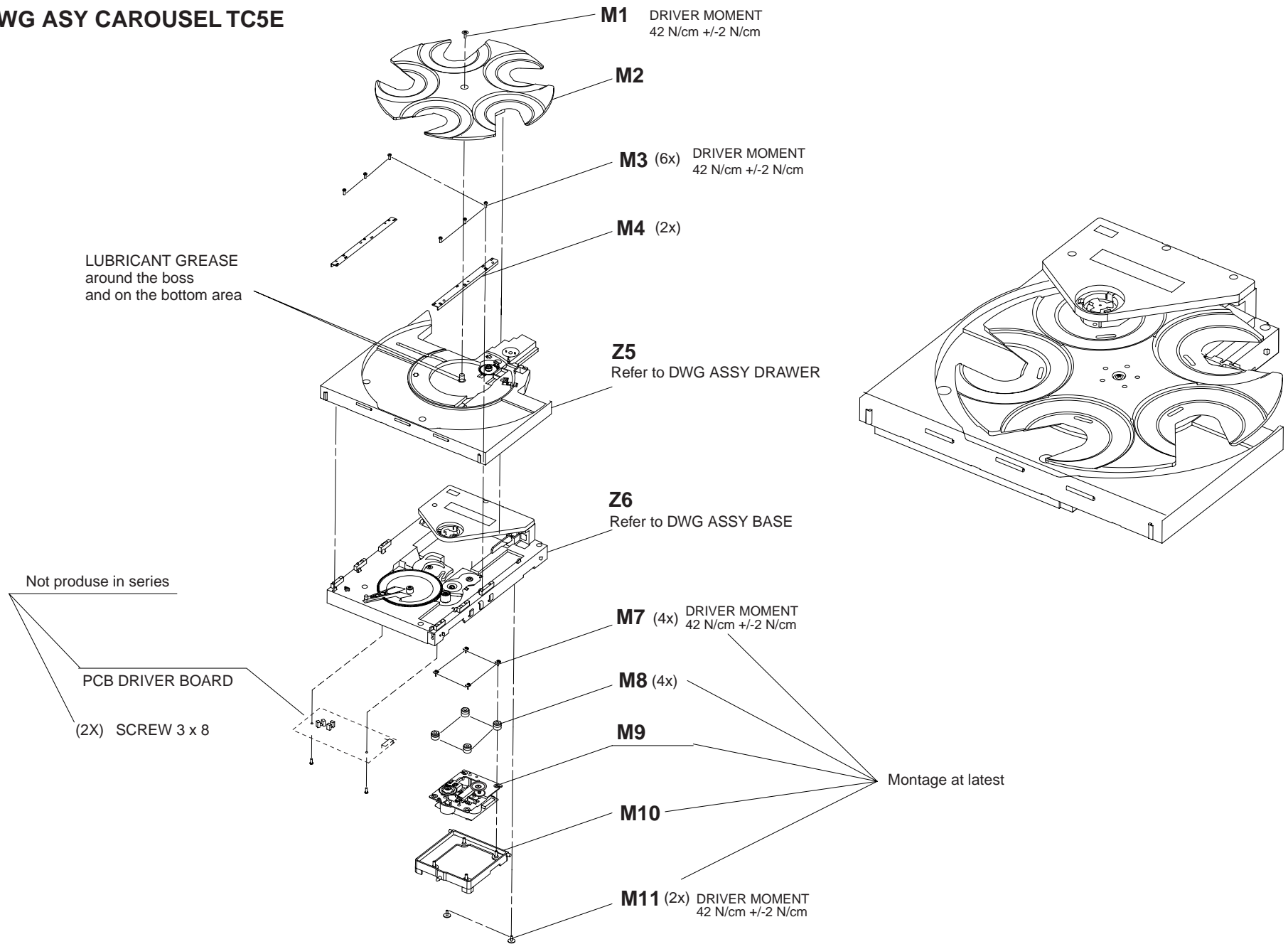

EXPLODED VIEWS OF DVD MECHANISM-2 DWG ASY BASE

CAM LIFTER
LUBRICANT GRASE
inside the curve

LUBRICANT GRASE
inside the curve

LUBRICANT GRASE
around the teeth

LUBRICANT GRASE
around the boss
and on the top area

LUBRICANT GRASE
around the boss
and on the bottom area

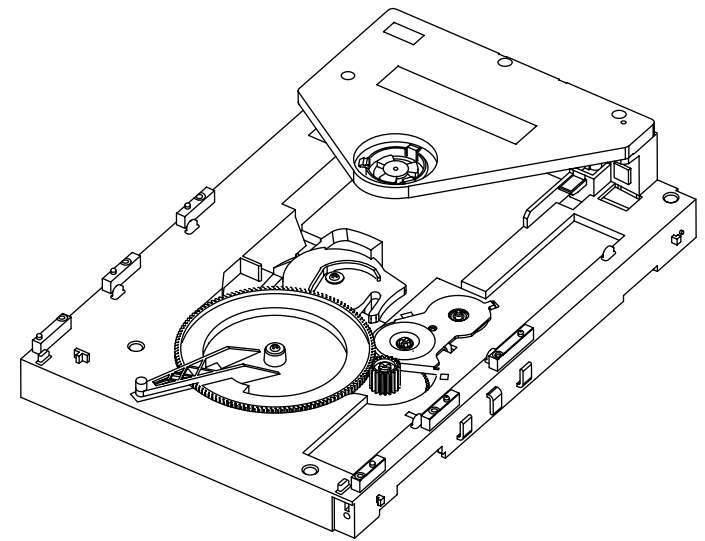
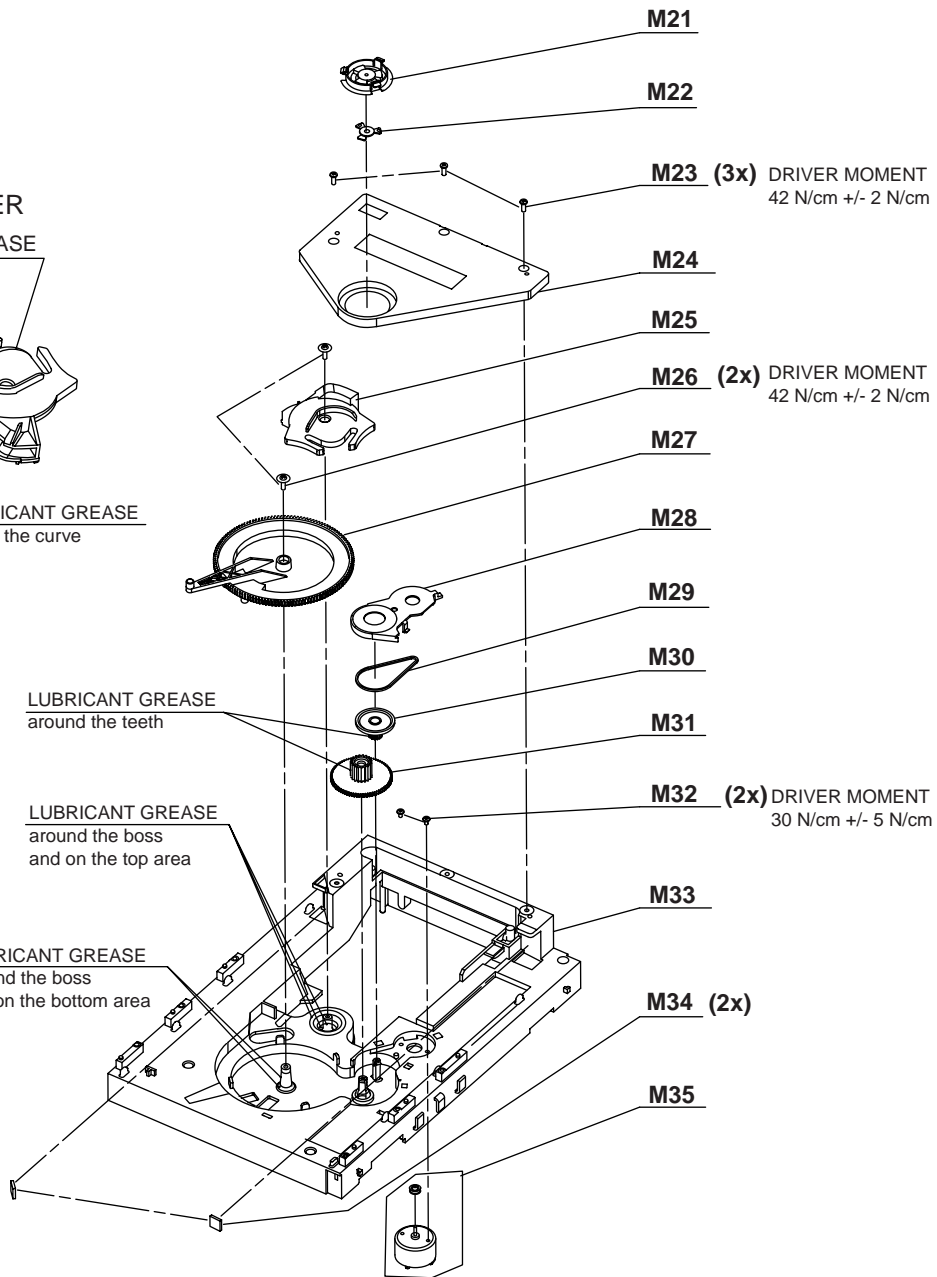

EXPLODED VIEWS OF DVD MECHANISM-3 DWS ASY DRAWER

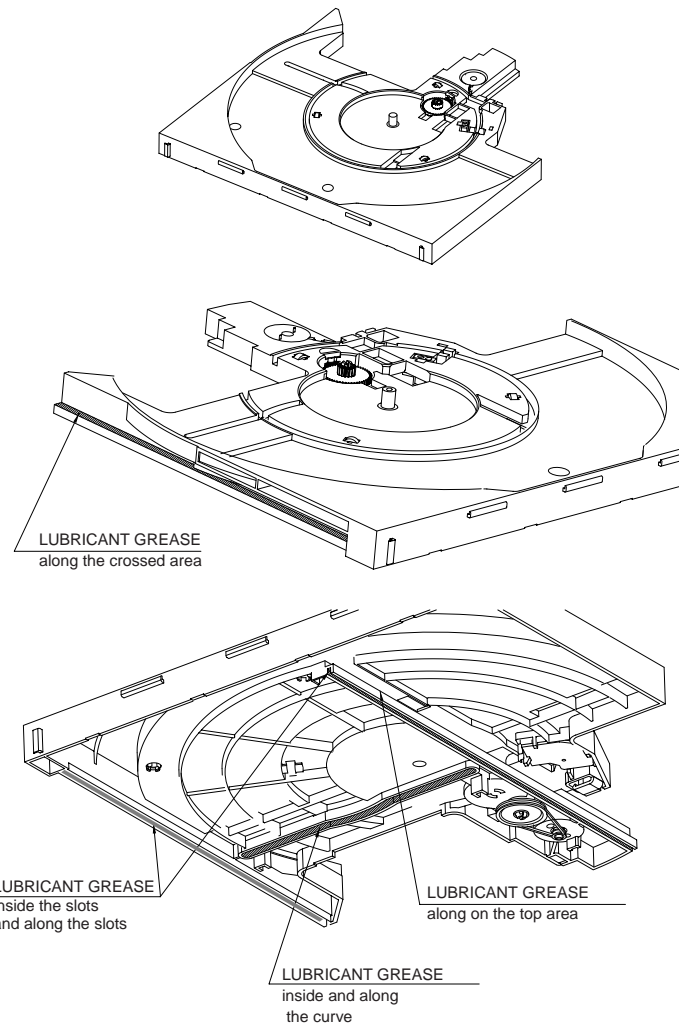
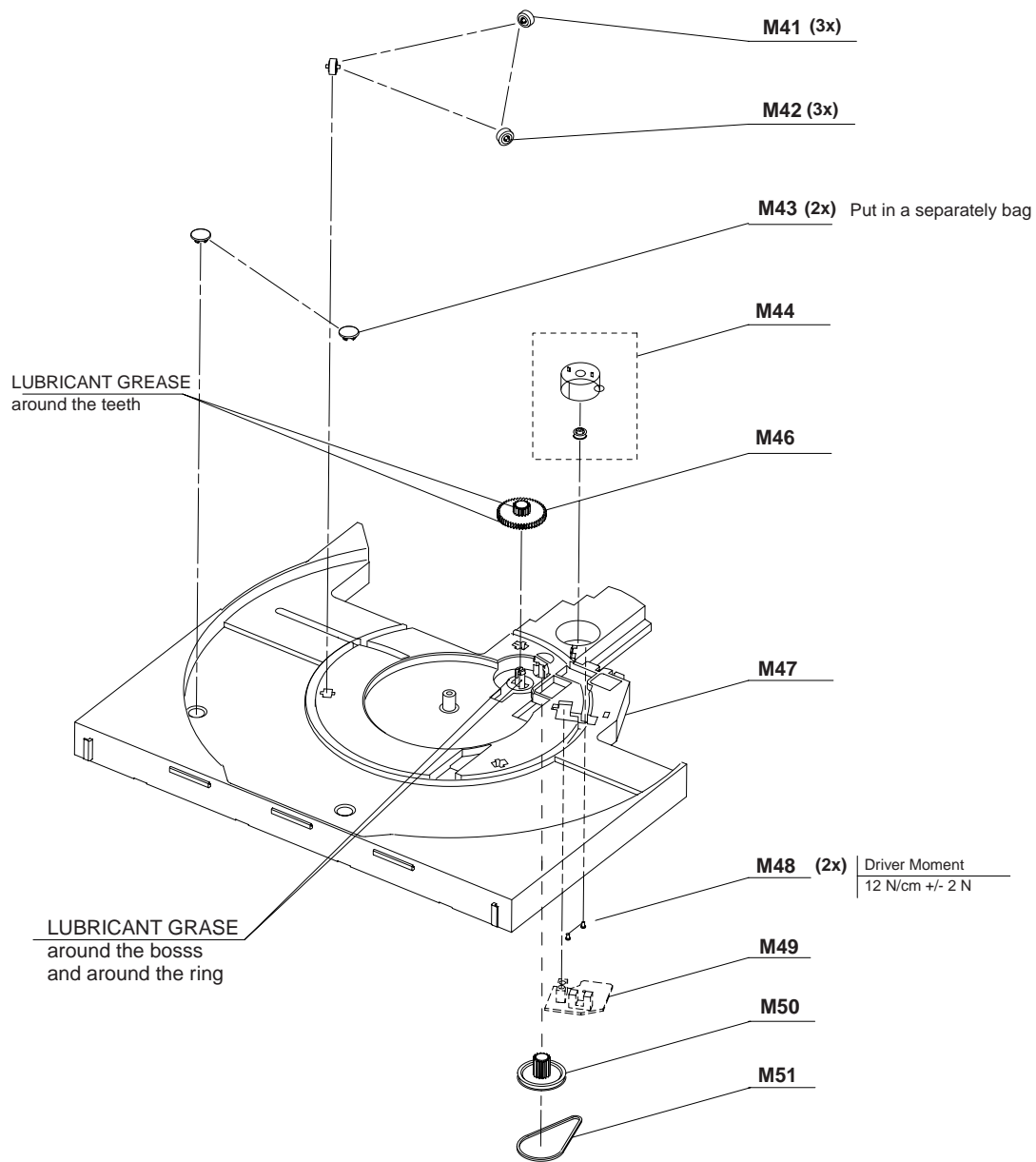

A

B

C

D

BLOCK DIAGRAM

1

2

3

4

5

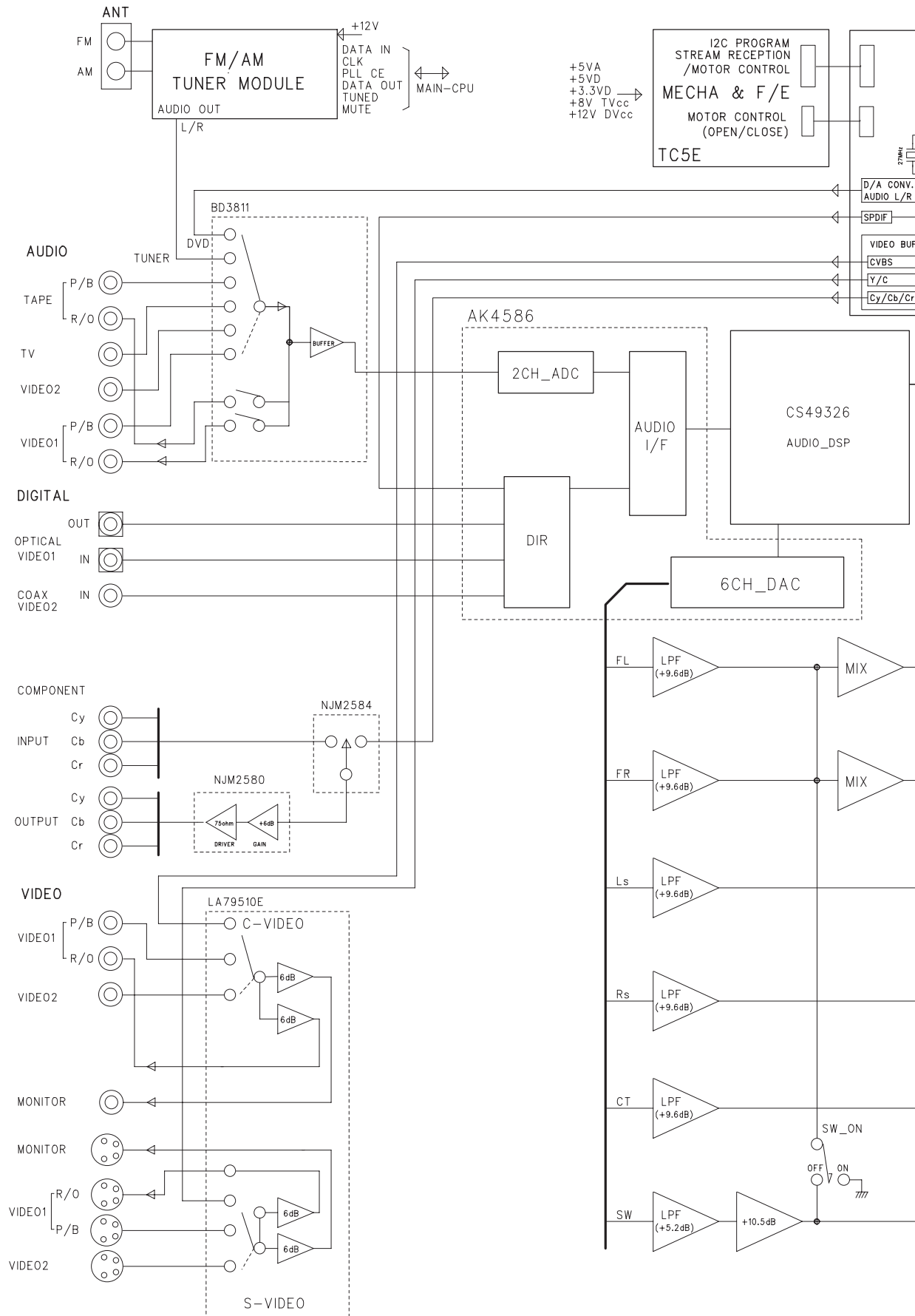

E

F

G

H

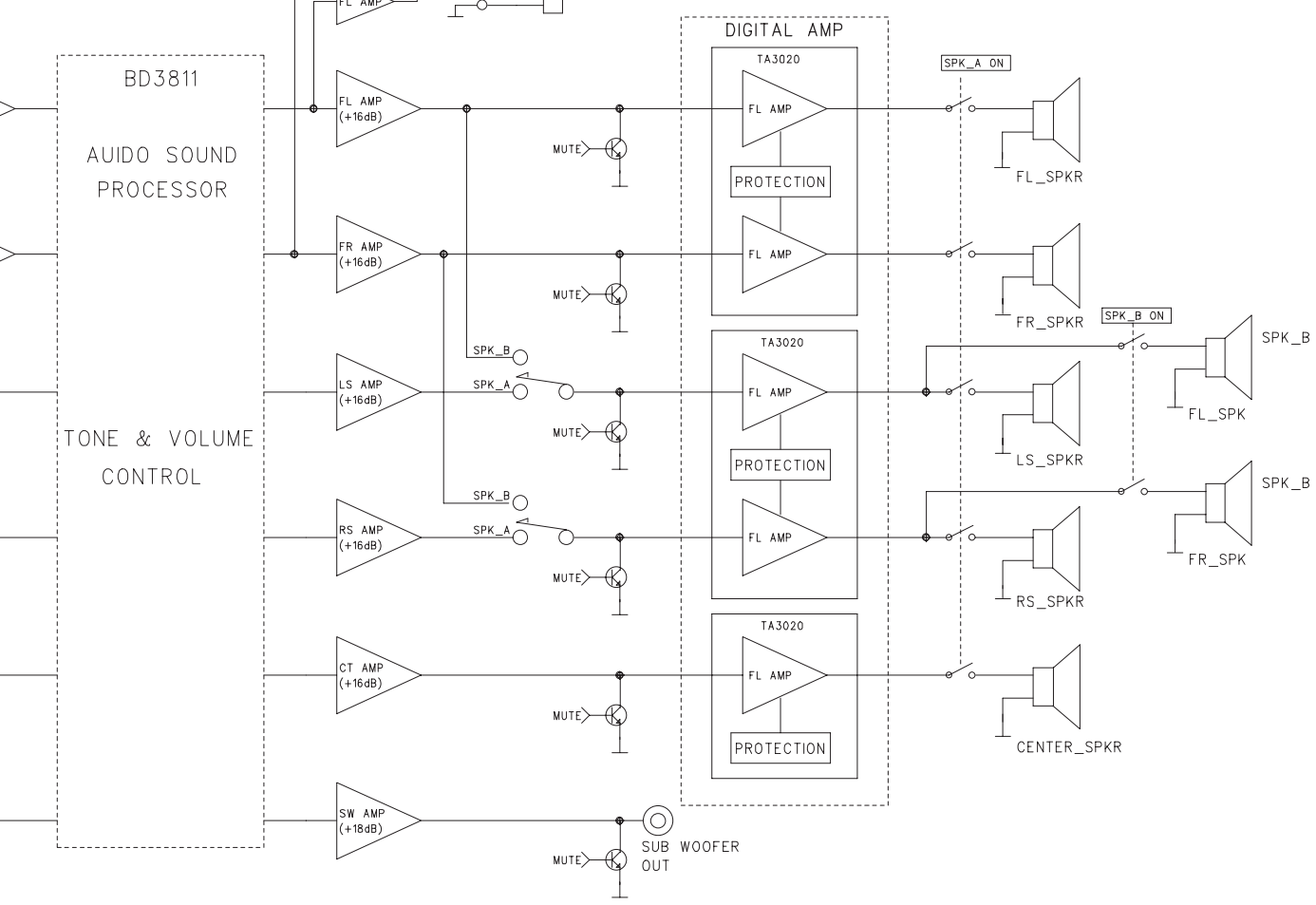
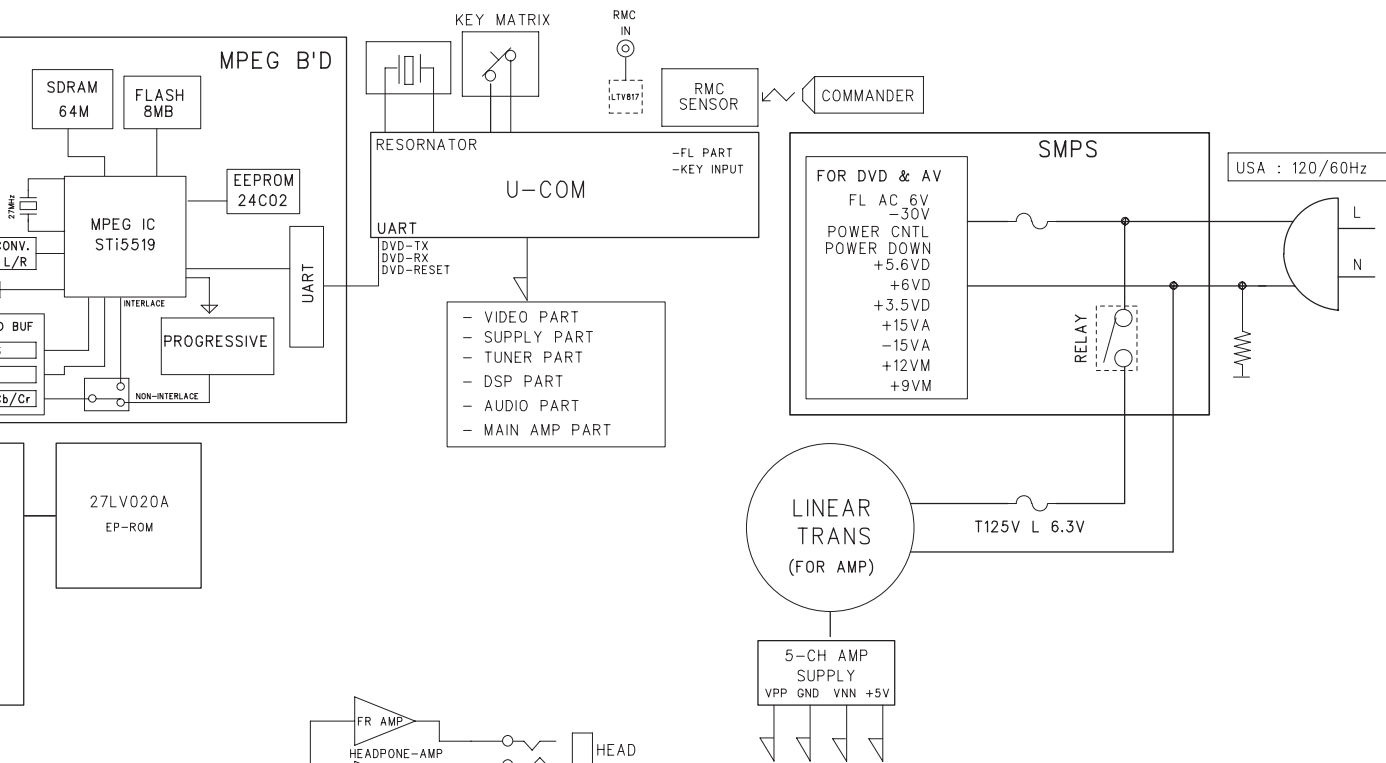

A B C D

SCHEMATIC DIAGRAMS-1

FRONT SECTION

1

2

3

4

5

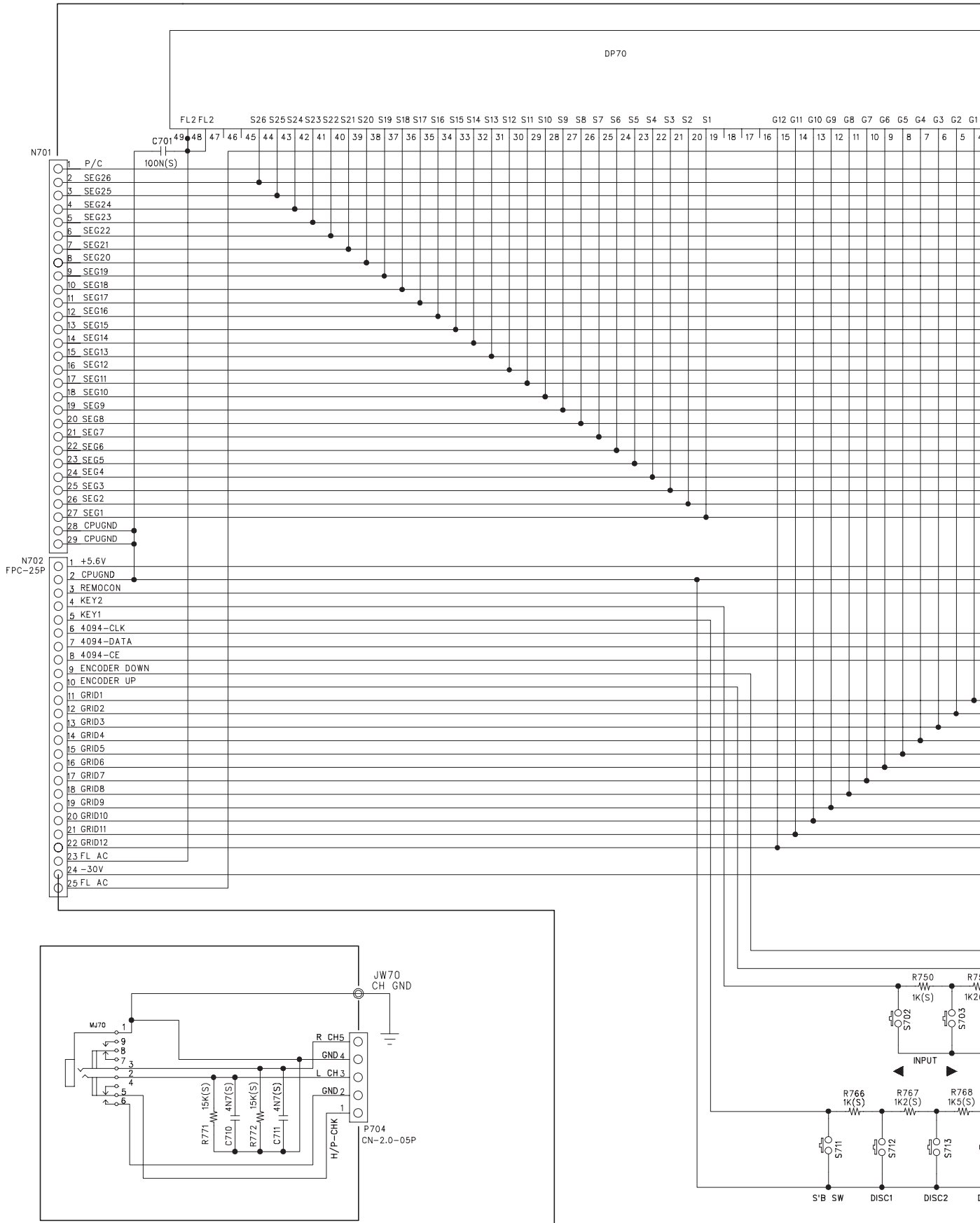

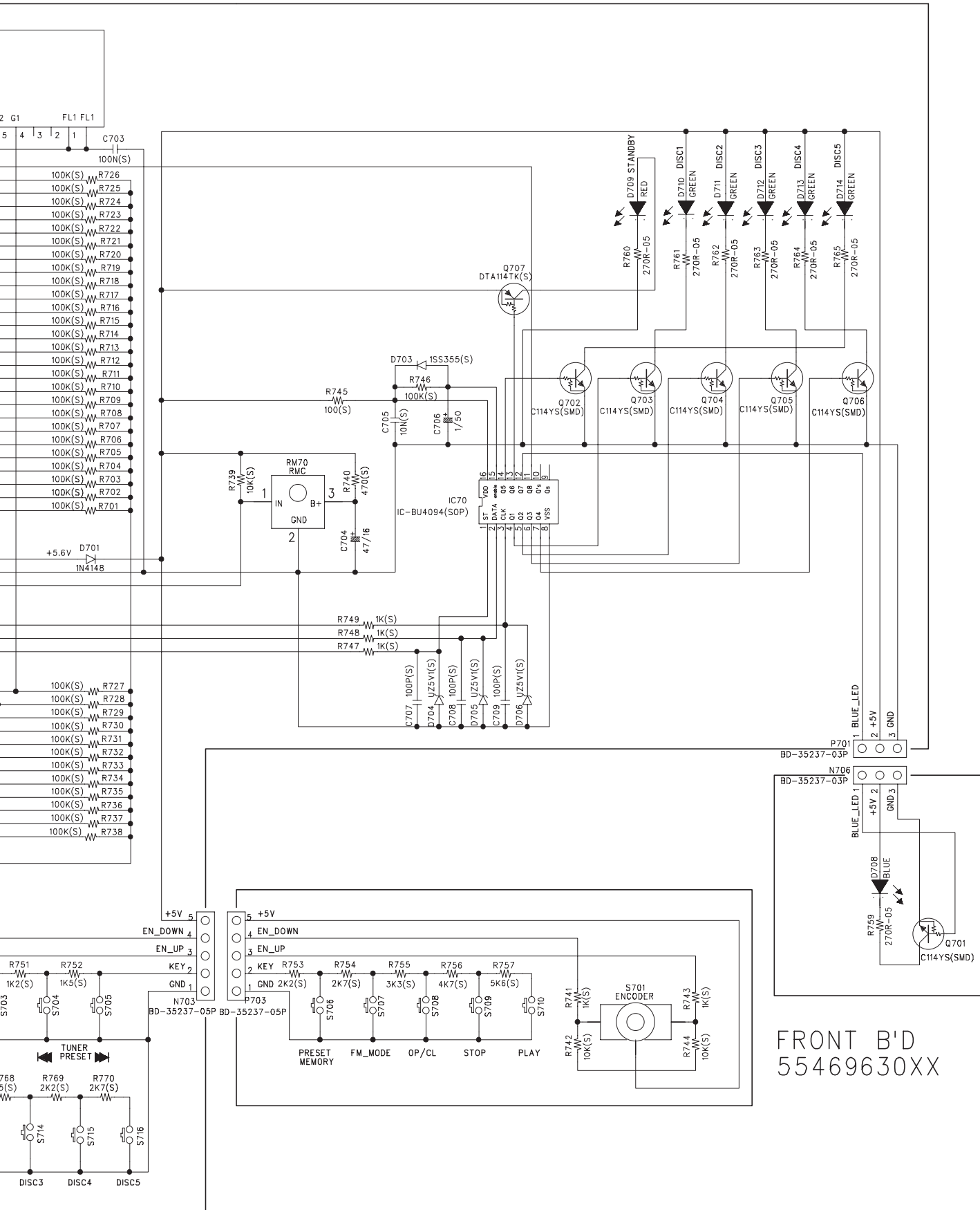

FRONT B'D
55469630XX

A

B

C

D

SCHEMATIC DIAGRAMS-2

1

2

3

4

5

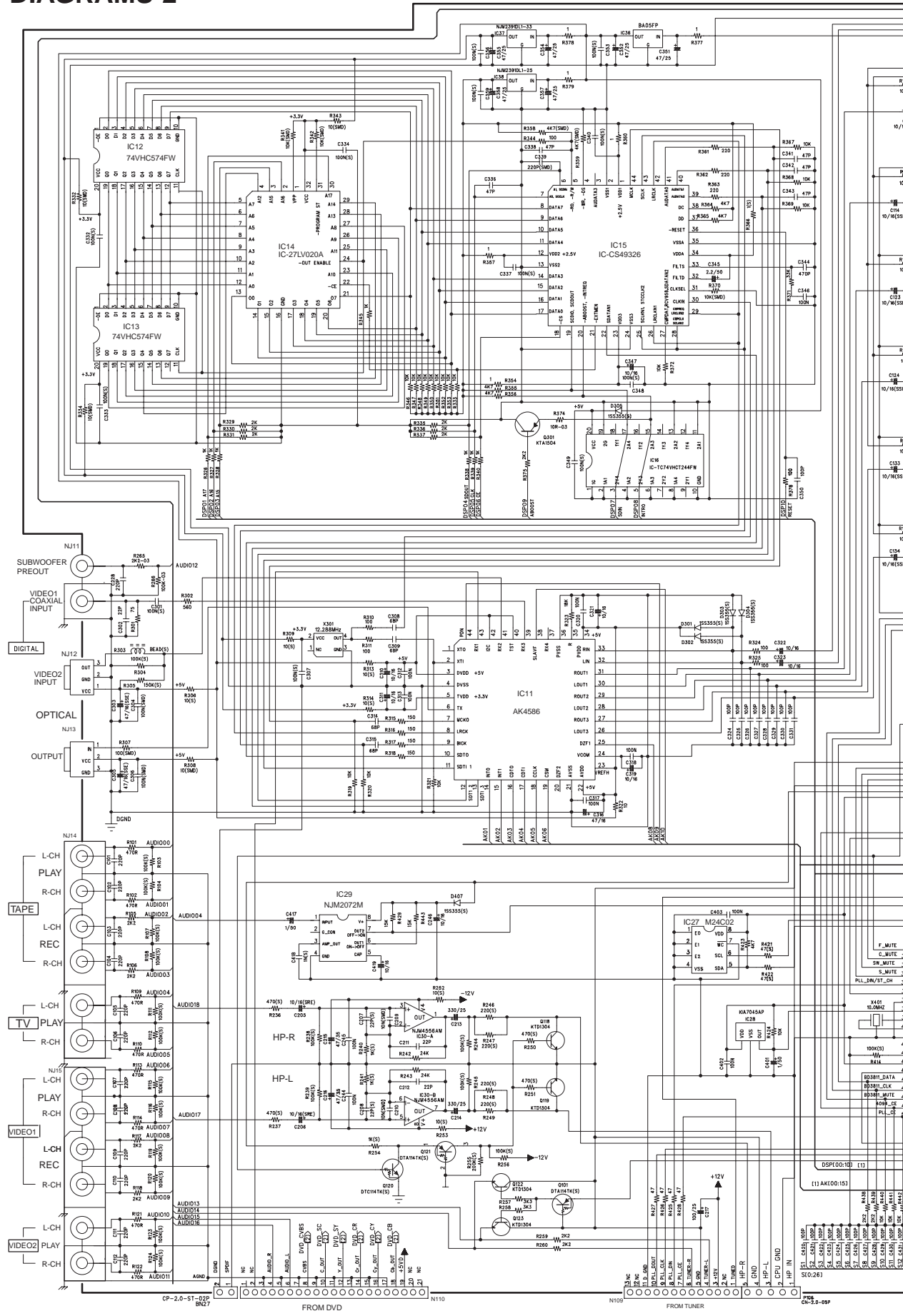

CP-2.0-ST-17-017

FROM DVD

N109

FROM TUNER

CH-2.0-SP

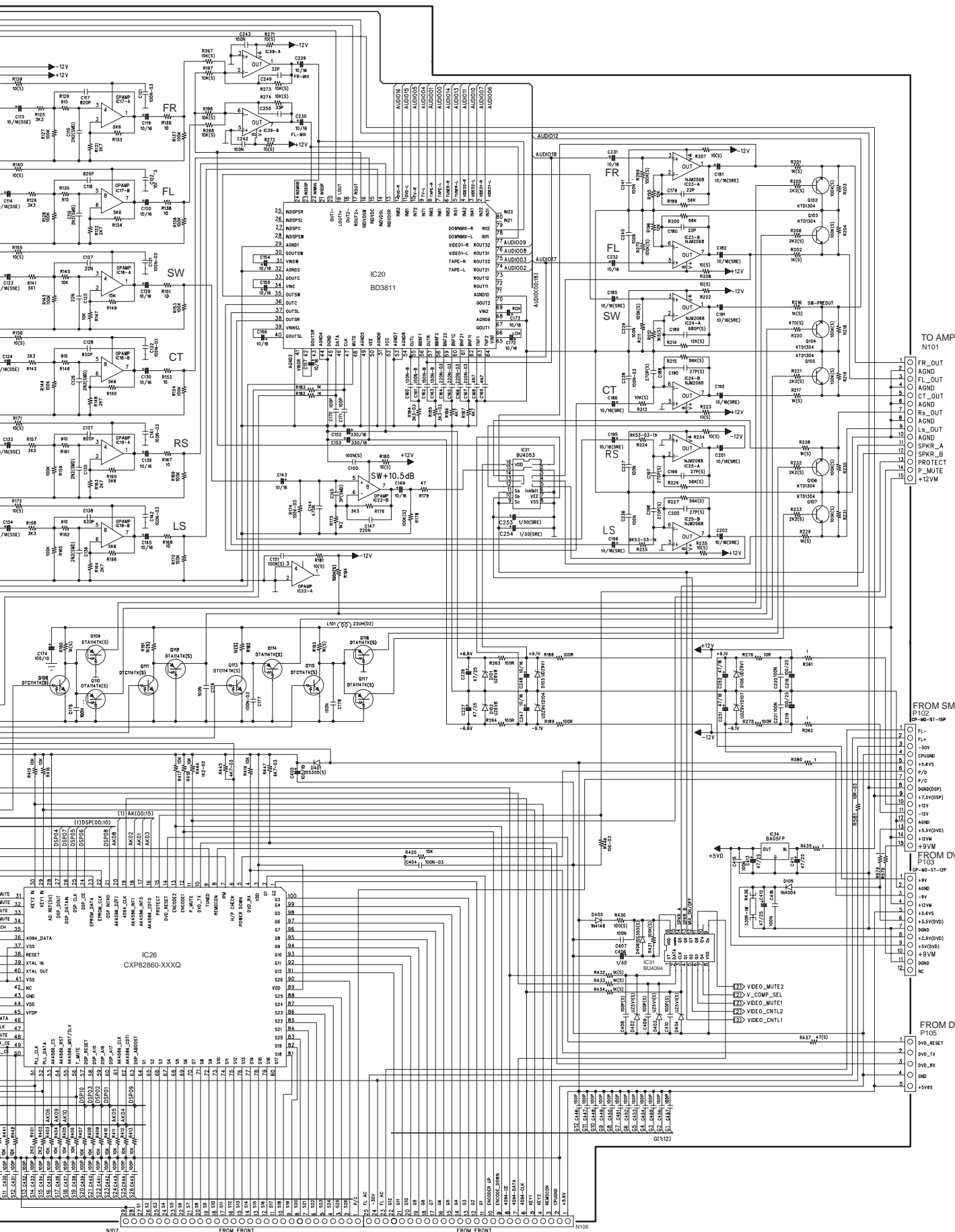

- TO AMP
N101
- 1 FR_OUT
 - 2 AGND
 - 3 FL_OUT
 - 4 AGND
 - 5 CT_OUT
 - 6 AGND
 - 7 Re_OUT
 - 8 AGND
 - 9 Ls_OUT
 - 10 AGND
 - 11 SPKR_A
 - 12 SPKR_B
 - 13 PROTECT
 - 14 P_MUTE
 - 15 +12V

- FROM SMPS
P102
SP-MS-ST-15P
- 1 FL-
 - 2 FL+
 - 3 -30V
 - 4 EPUGND
 - 5 +5.8V
 - 6 P/P
 - 7 P/C
 - 8 DNR(DSP)
 - 9 +7.5V(DSP)
 - 10 +12V
 - 11 +5.0V
 - 12 AGND
 - 13 +3.3V(DV0)
 - 14 +12V
 - 15 +5.0V

- FROM DVD
P103
SP-MS-ST-12P
- 1 AGND
 - 2 +5V
 - 3 +12V
 - 4 +5.8V
 - 5 +3.3V(DV0)
 - 6 DNR0
 - 7 DNR1
 - 8 DNR2
 - 9 +5.0V(DV0)
 - 10 +5.0V(DV0)
 - 11 +5.0V
 - 12 NC

- FROM DVD
P105
- 1 DVD_RESET
 - 2 DVD_TX
 - 3 DVD_RX
 - 4 DNR
 - 5 +5V

N107

FROM FRONT

FROM FRONT

N106

A B C D
SCHEMATIC DIAGRAMS-3
MAIN VIDEO SECTION

1

2

3

4

5

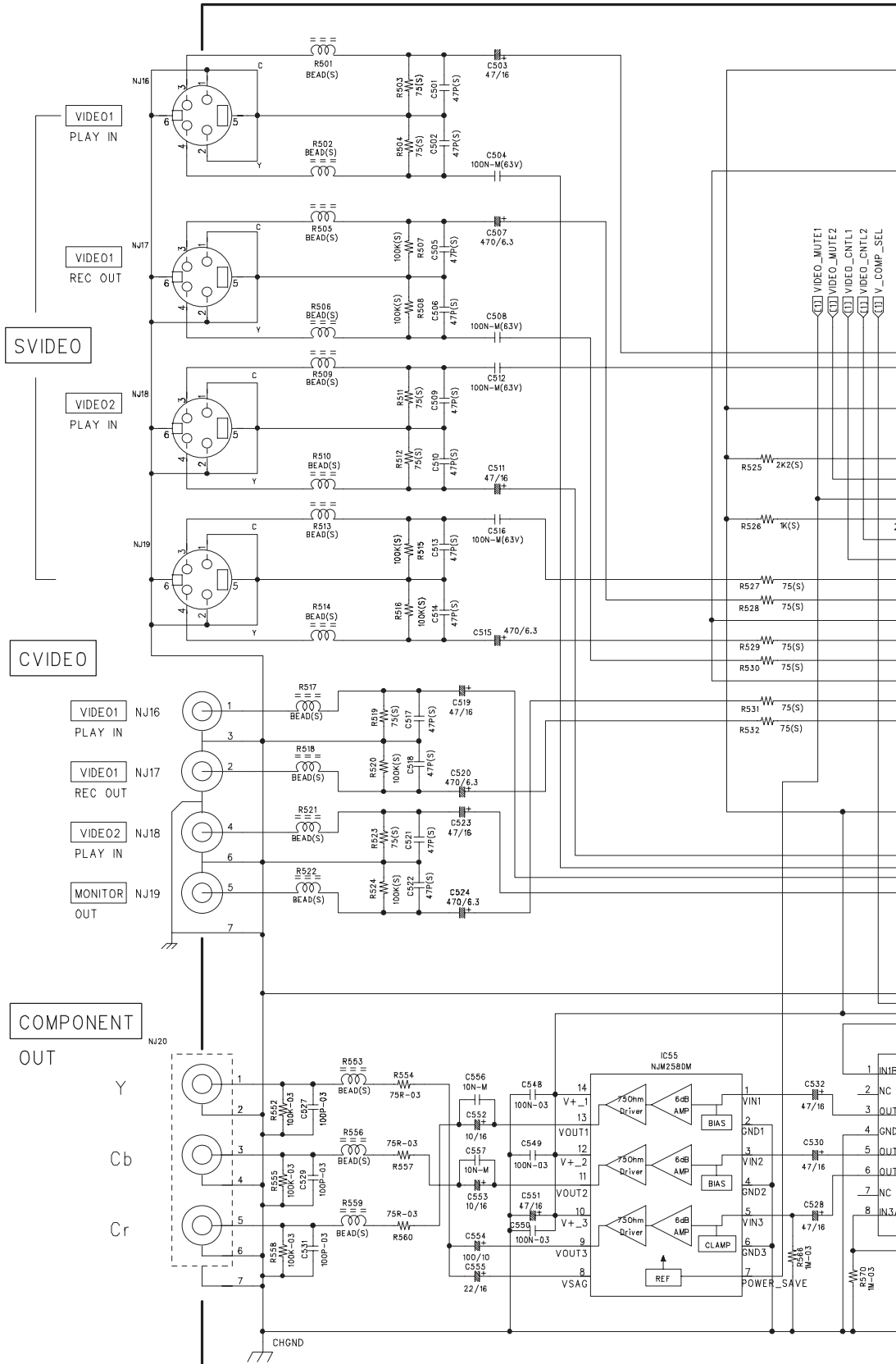

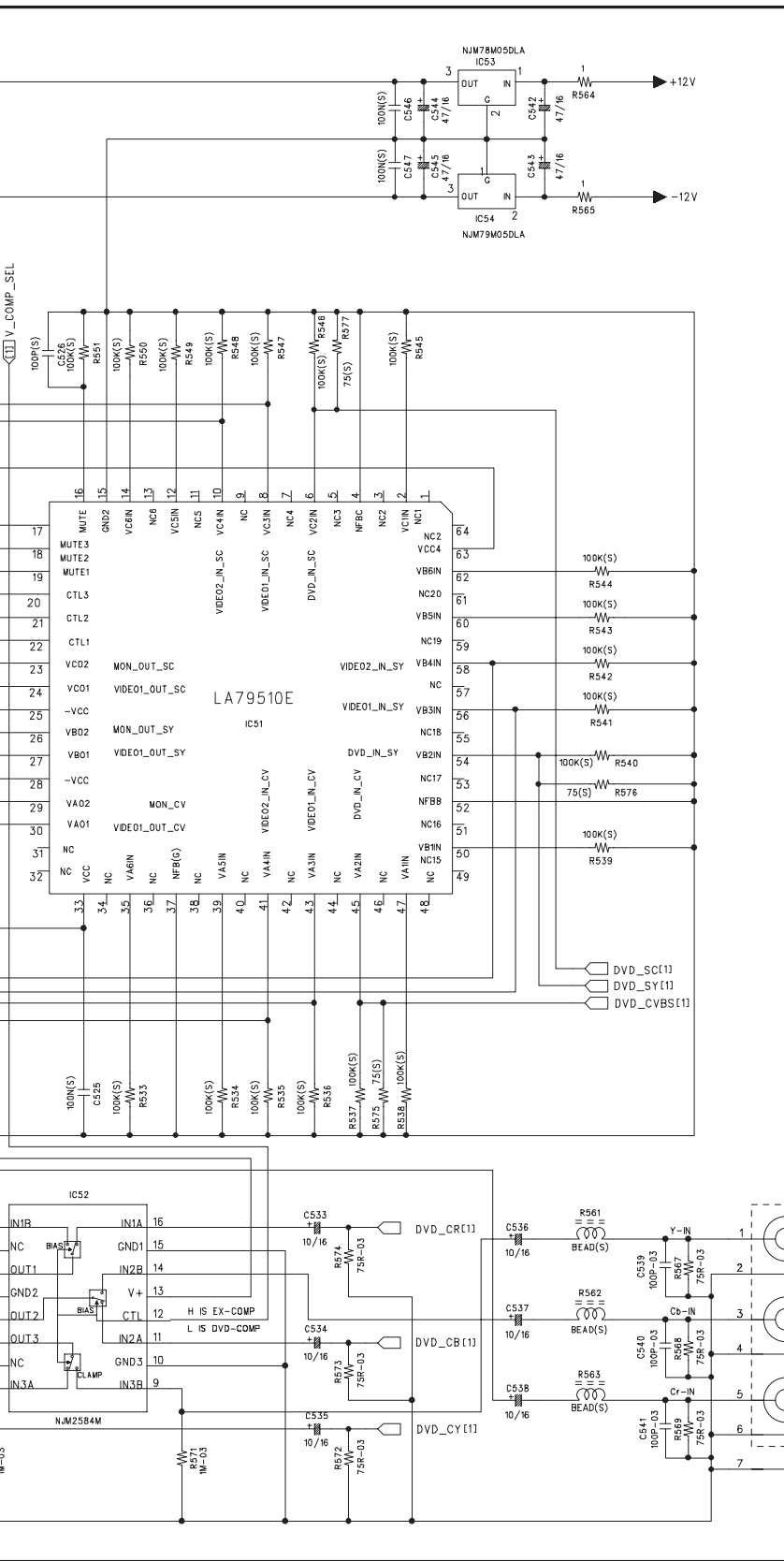

COMPONENT

- IN
- Y
- Cb
- Cr

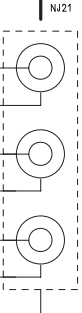

A

B

C

D

SCHEMATIC DIAGRAMS-4 DVD SECTION

1

2

3

4

5

- IC11 IC-VIDEOPROC PM0028A LOFP80 PIONEER VIDEO PROCESSOR
- IC12 IC-VIDEOPROC M1568A/B/C SSOP34A MITSUMI AMPLIFIER&DRIVER
- IC13 IC-REGSPECKT TL431
- IC14 IC-LOGIC 74HC74 FLIP/FLOP CMOS
- IC15 IC-LOGIC 74HC86 GATE HCMOS
- IC21 IC-VIDEOPROC ST15519 MPEG VIDEO DECODER
- IC22 IC-EEPROM M24C02WMN6
- IC31 IC-DRAM HY57V651620BTC-8 125M 64M(M+16+4)
- IC41 IC-MEMFLASH M29W800AT90N1
- IC51 IC-LOGIC M74HC04MR INVERTER HCT
- IC61 IC-CONV WM8728 D/A
- IC62 IC-OPAMP BA4560F DUAL OP
- ICP1 IC-REGPO5FXD KIA7805PI NORMAL

From PICK UP TO MAIN BD

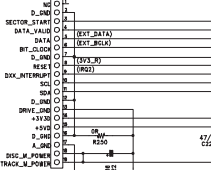

From MAIN BD to FRONT BD

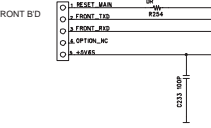

DVD_BD

5CHANGER ONLY

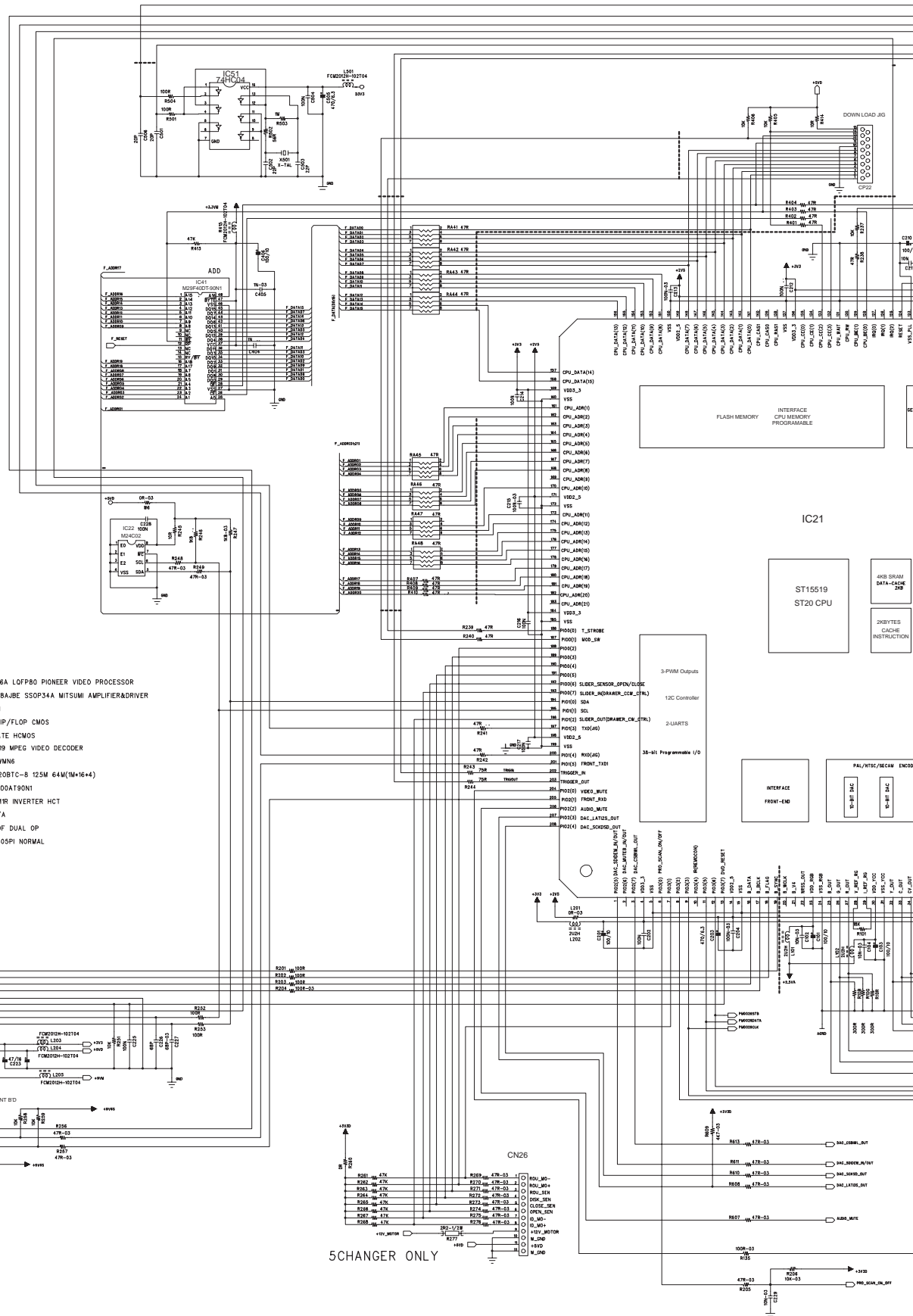

E

F

G

H

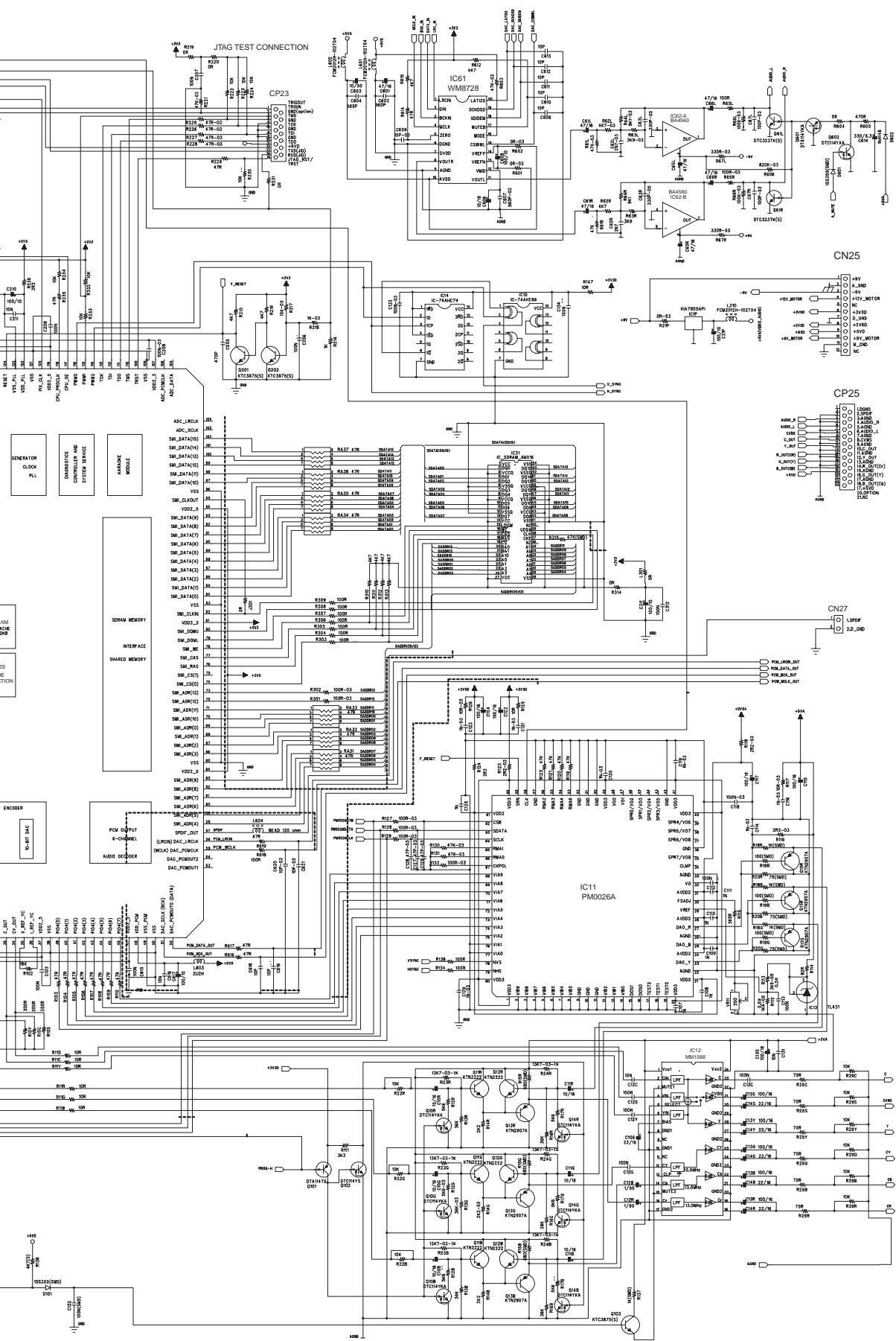

A

B

C

D

SCHEMATIC DIAGRAMS-5 MECHANISM CONTROL SECTION

1

2

3

4

5

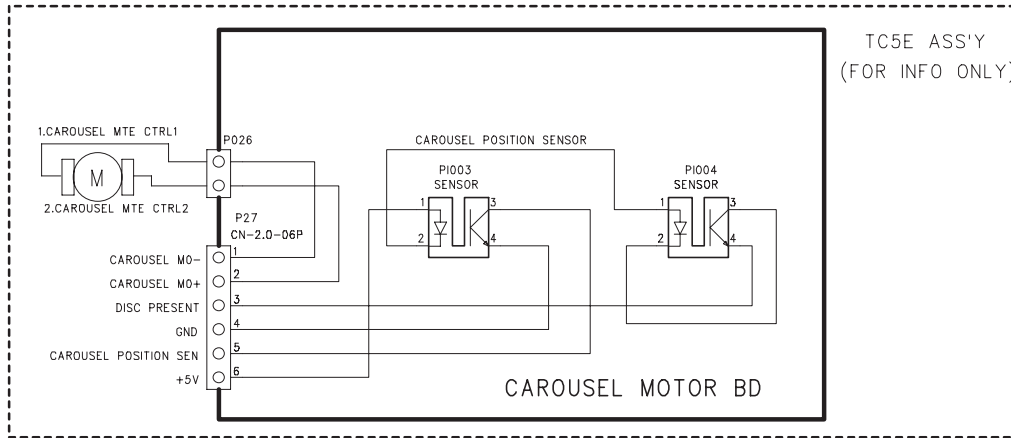
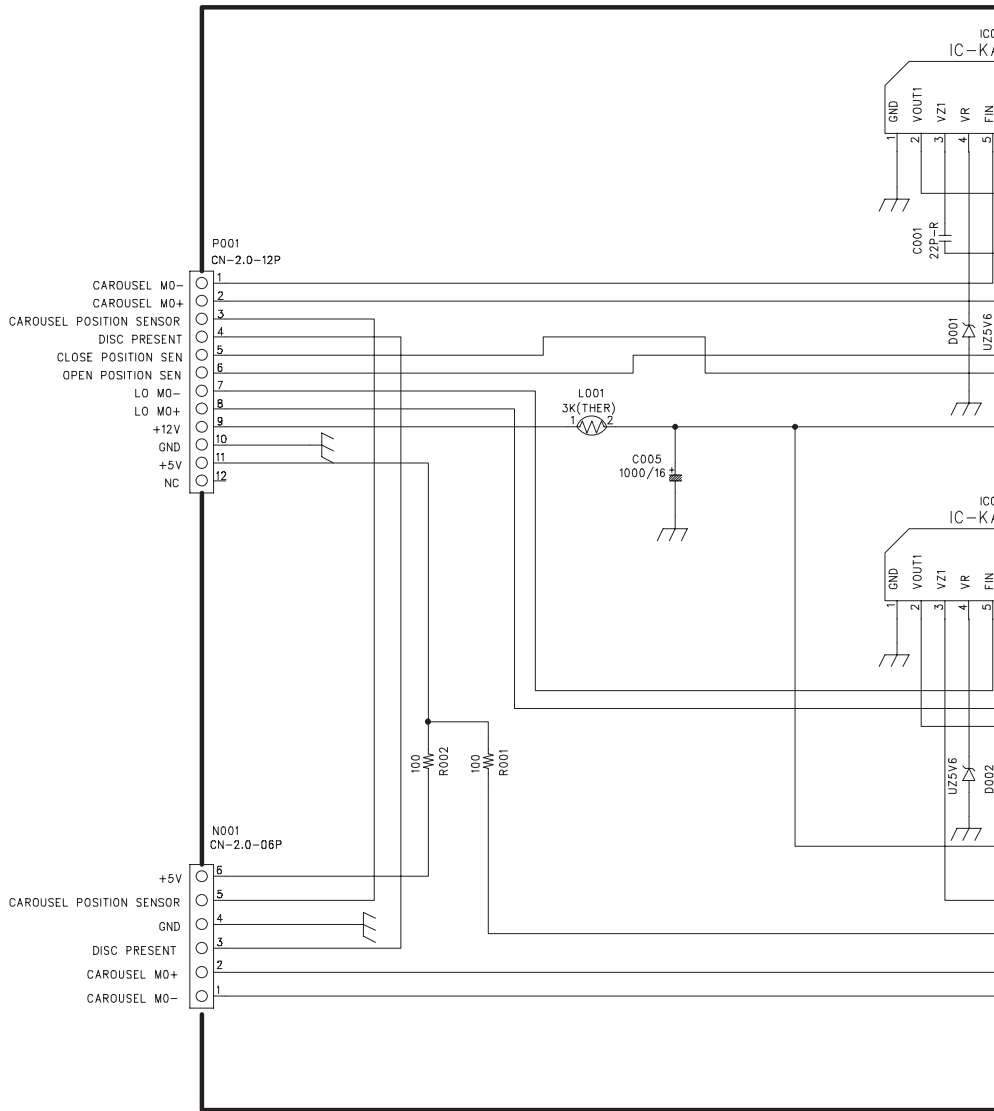

A

B

C

D

SCHEMATIC DIAGRAMS-6 POWER SUPPLY SECTION

1

2

3

4

5

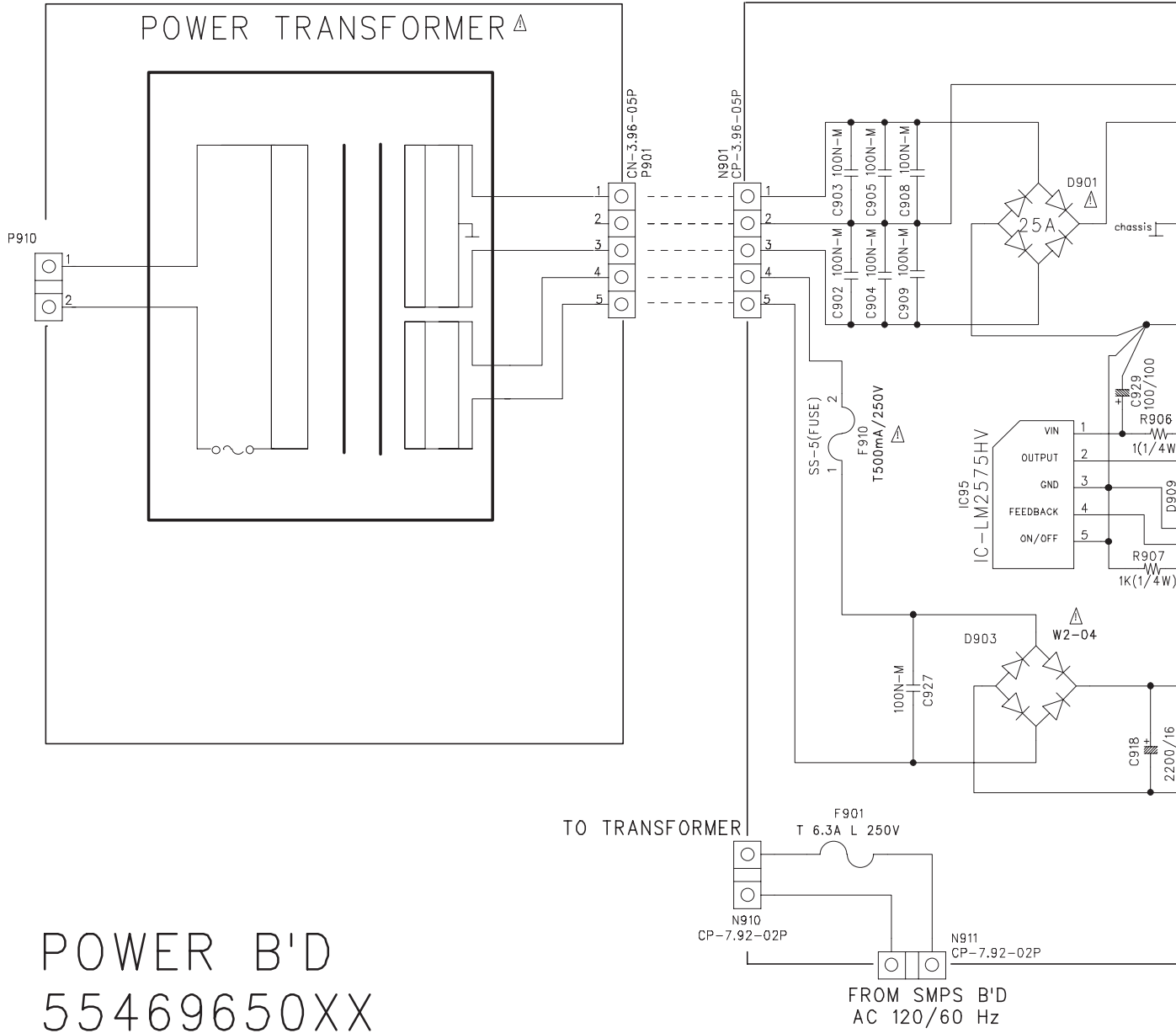

POWER B'D
55469650XX

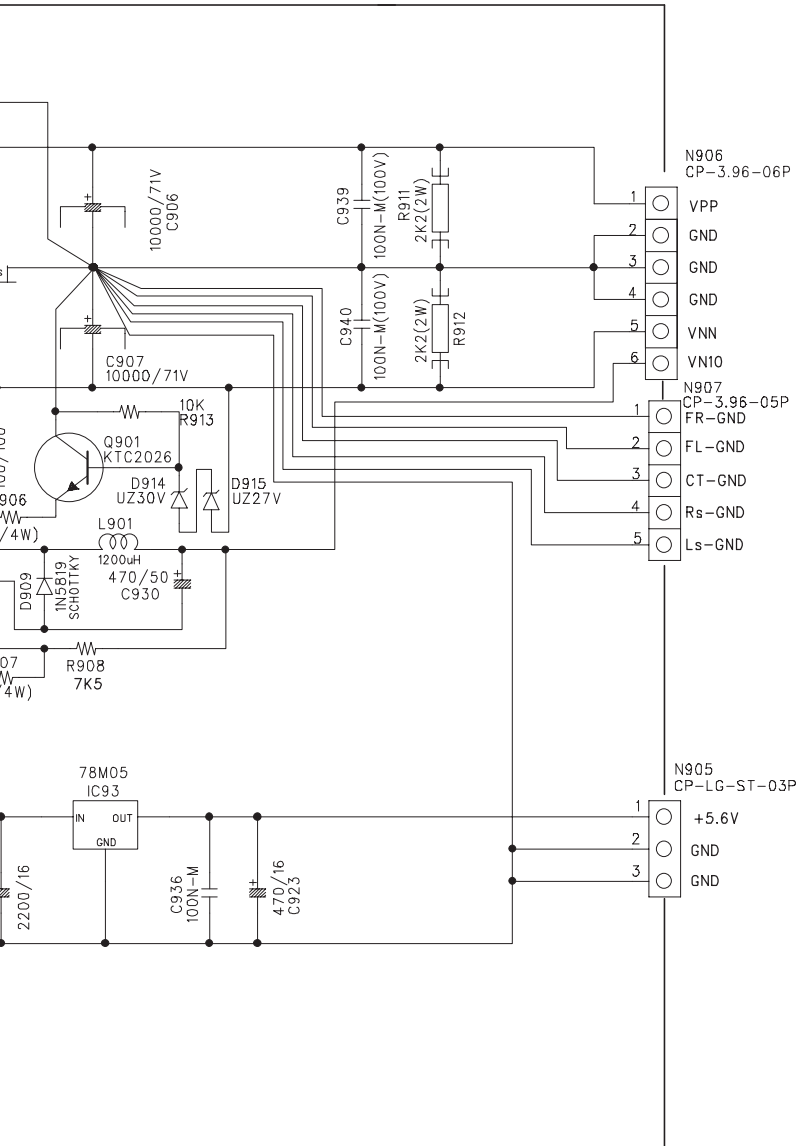

TO D-AMP B'd

TO D-AMP B'd

TO D-AMP B'd

CAUTION: 

COMPONENTS DESIGNED BY THE SAFETY SYMBOL SHOULD. WHEN NECESSARY FOR REPAIR BE REPLACED BY ORIGINAL PARTS. APPROVED BY THE MANUFACTURER. ONLY THEN CAN THE OPERATIONAL SAFETY BE GUARANTEED.

NOTES:

1. Resistor values are indicated in ohms unless otherwise specified (k=1,000 M=1,000,000)
2. Capacitor values are indicated in microfarads unless otherwise specified. (p=micro-microfarades)
3.  indicates critical safety components. Replace only with those specified from replacement parts list to maintain proper performances and safety of this unit

SCHEMATIC DIAGRAMS-7

POWER AMPLIFIER SECTION(FL/FR)

1
2
3
4
5

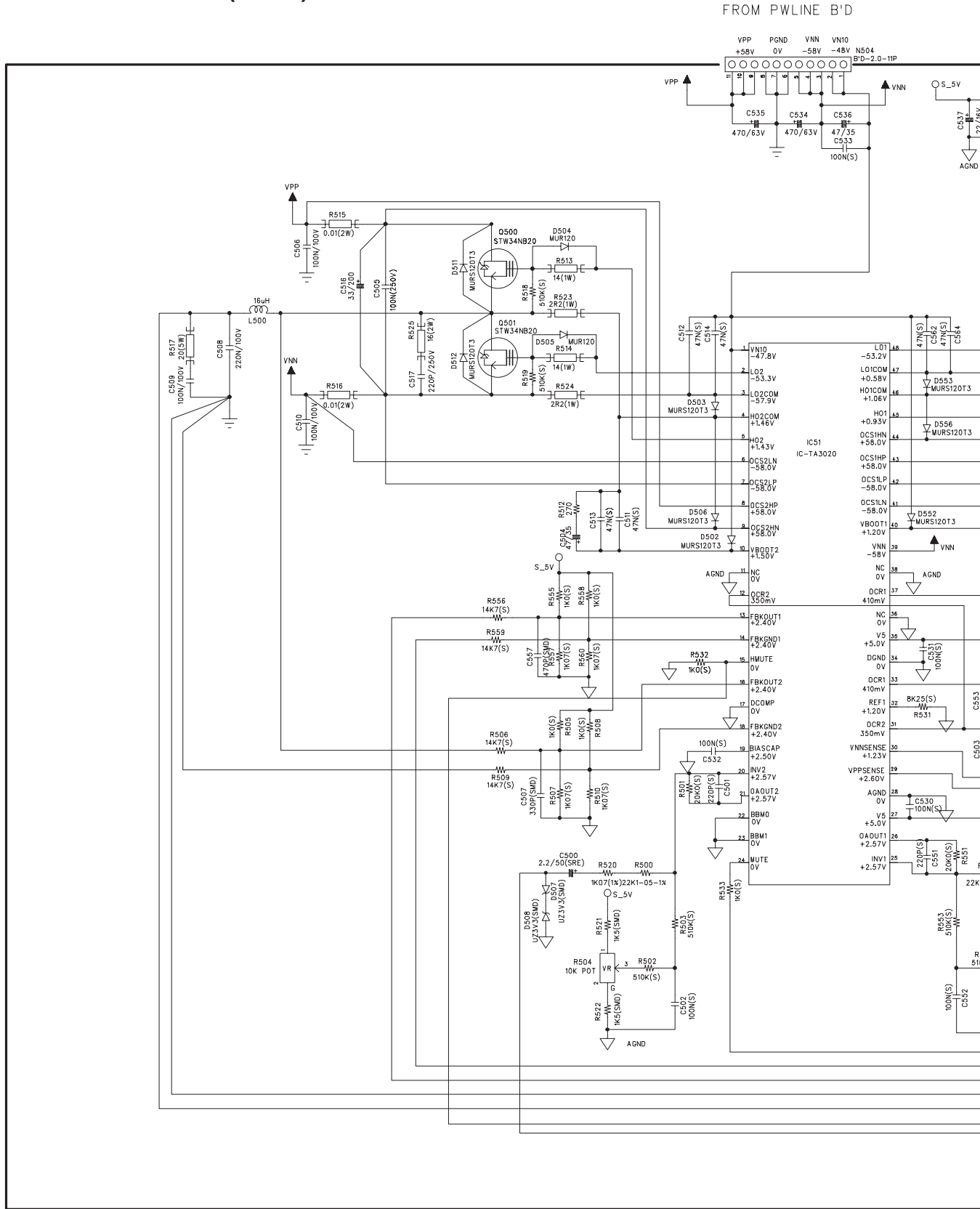

FROM POWER B'D

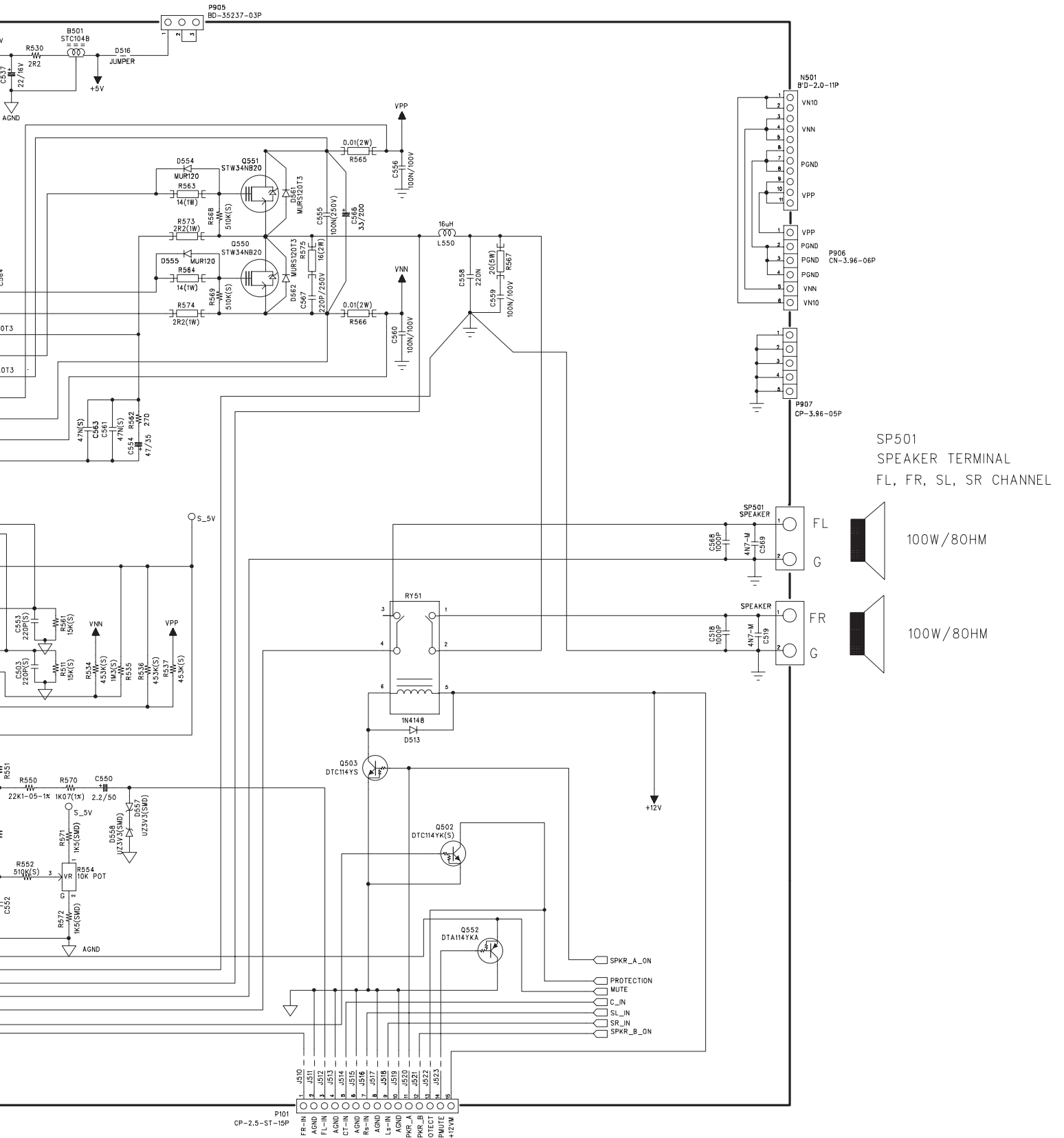

FROM MAIN B'D

SP501
SPEAKER TERMINAL
FL, FR, SL, SR CHANNEL

100W/80HM

100W/80HM

- 1 J510
- 2 J511
- 3 J512
- 4 J513
- 5 J514
- 6 J515
- 7 J516
- 8 J517
- 9 J518
- 10 J519
- 11 J520
- 12 J521
- 13 J522
- 14 J523
- 15
- 16

P101
CP-2.5-ST-15P

- PROTECTION
- MUTE
- C_IN
- SL_IN
- SR_IN
- SPKR_B_ON
- SPKR_A_ON

SCHEMATIC DIAGRAMS-7

POWER AMPLIFIER SECTION(FL/FR)

1

2

3

4

5

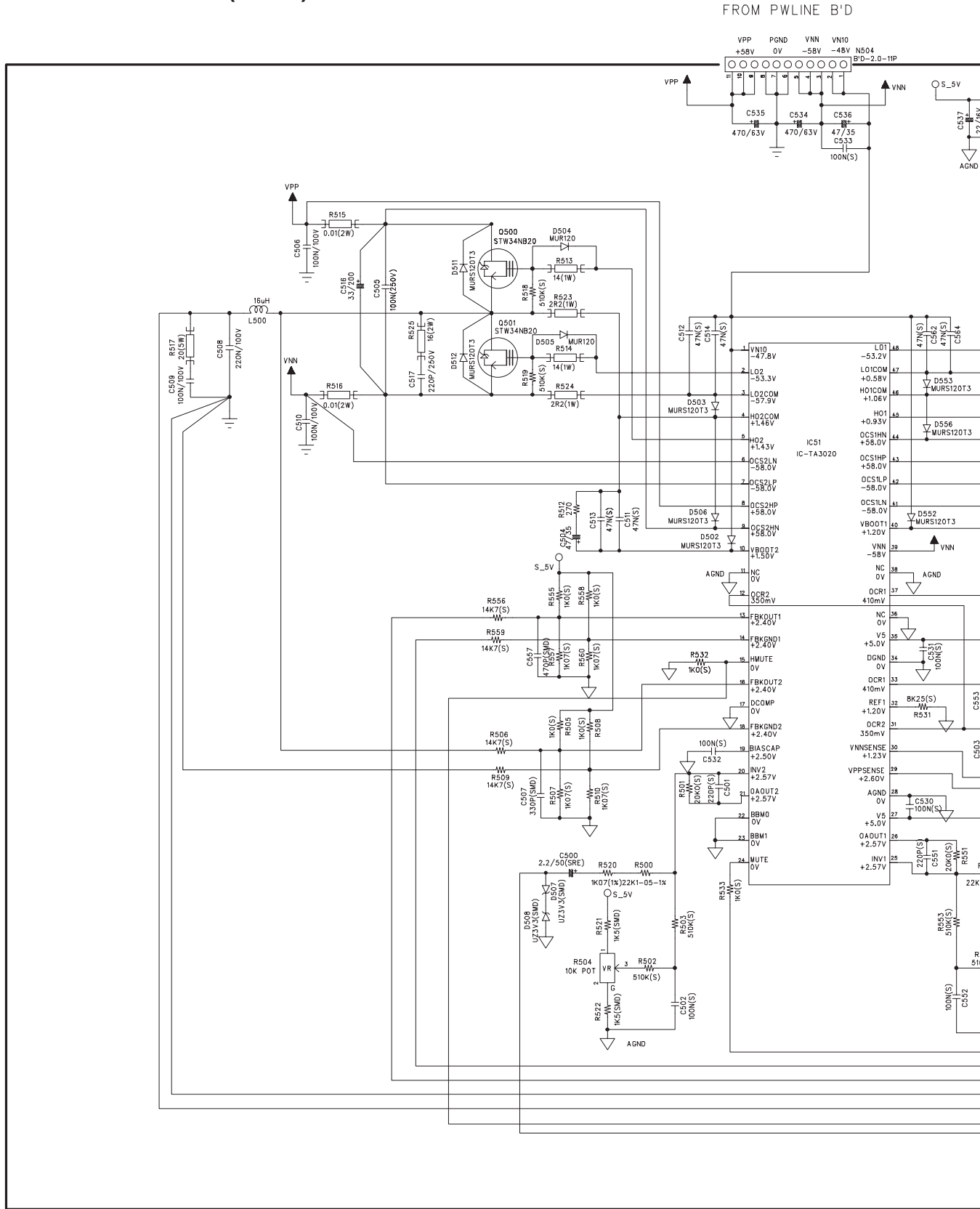

FROM POWER B'D

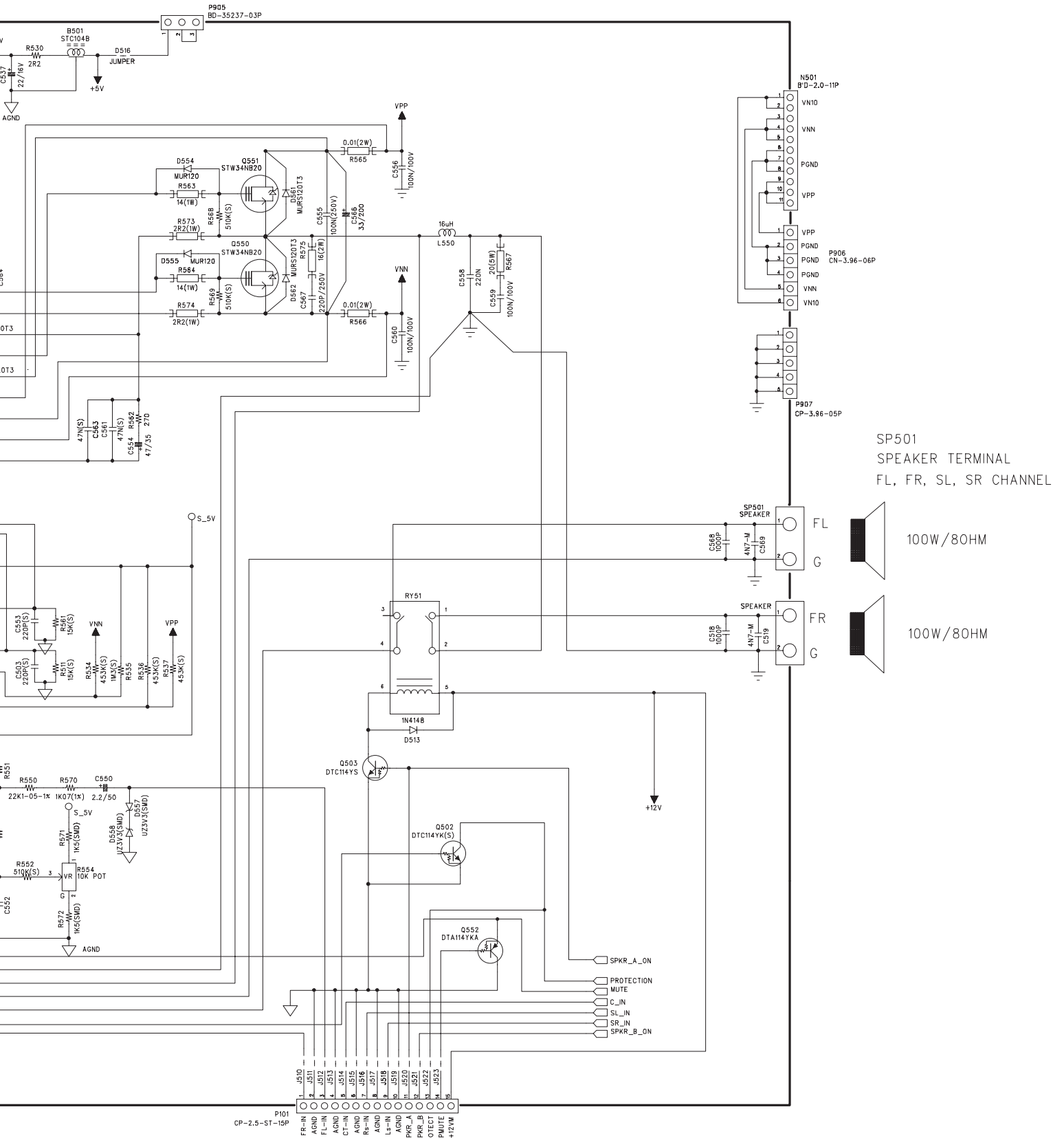

FROM MAIN B'D

SP501
SPEAKER TERMINAL
FL, FR, SL, SR CHANNEL

100W/80HM

100W/80HM

A B C D

SCHEMATIC DIAGRAMS-7

POWER AMPLIFIER SECTION(FL/FR)

1
2
3
4
5

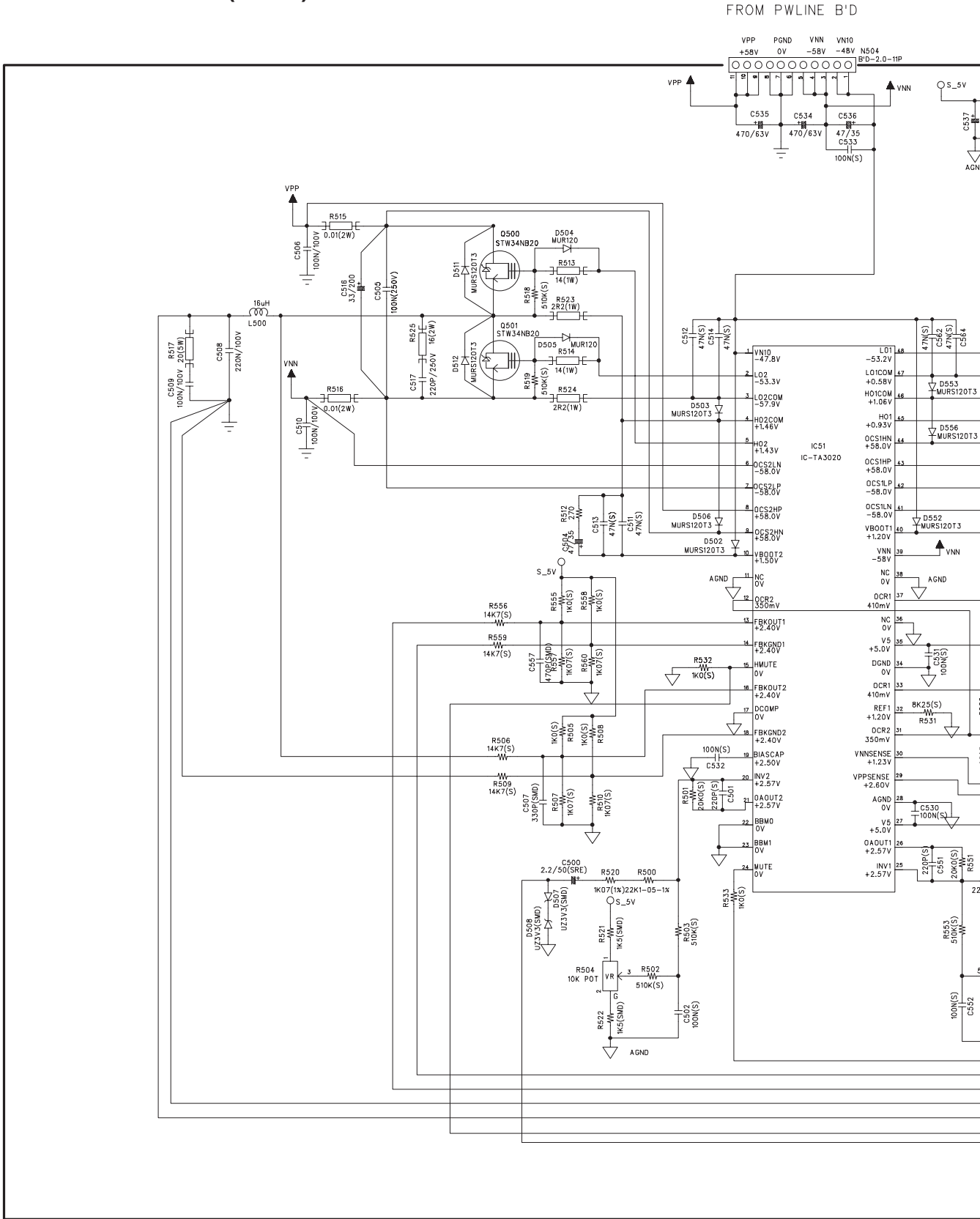

FROM POWER B'D

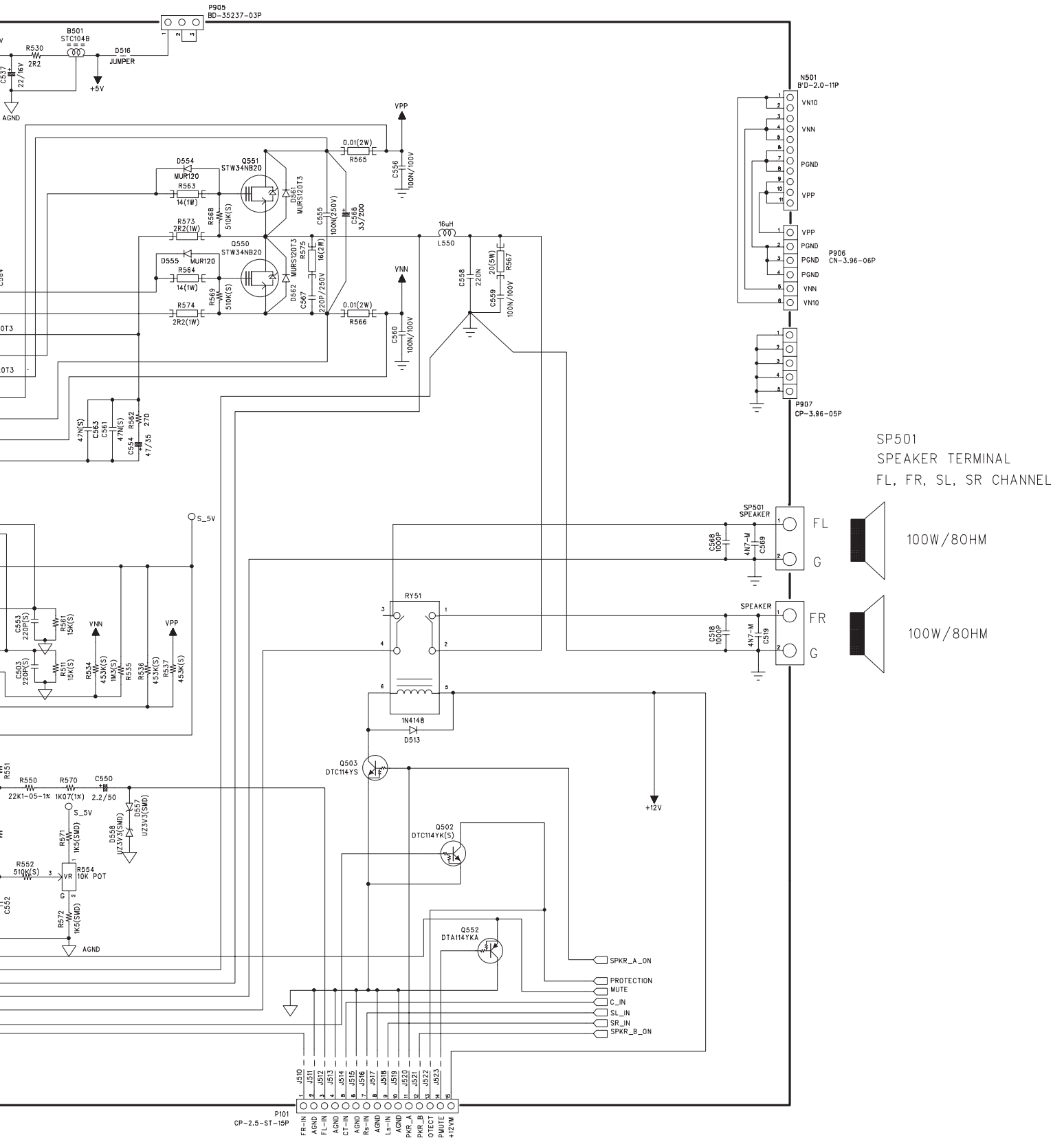

FROM MAIN B'D

A

B

C

D

SCHEMATIC DIAGRAMS-8

POWER AMPLIFIER SECTION(CENTER)

FROM P/WLINE B'D

1

2

3

4

5

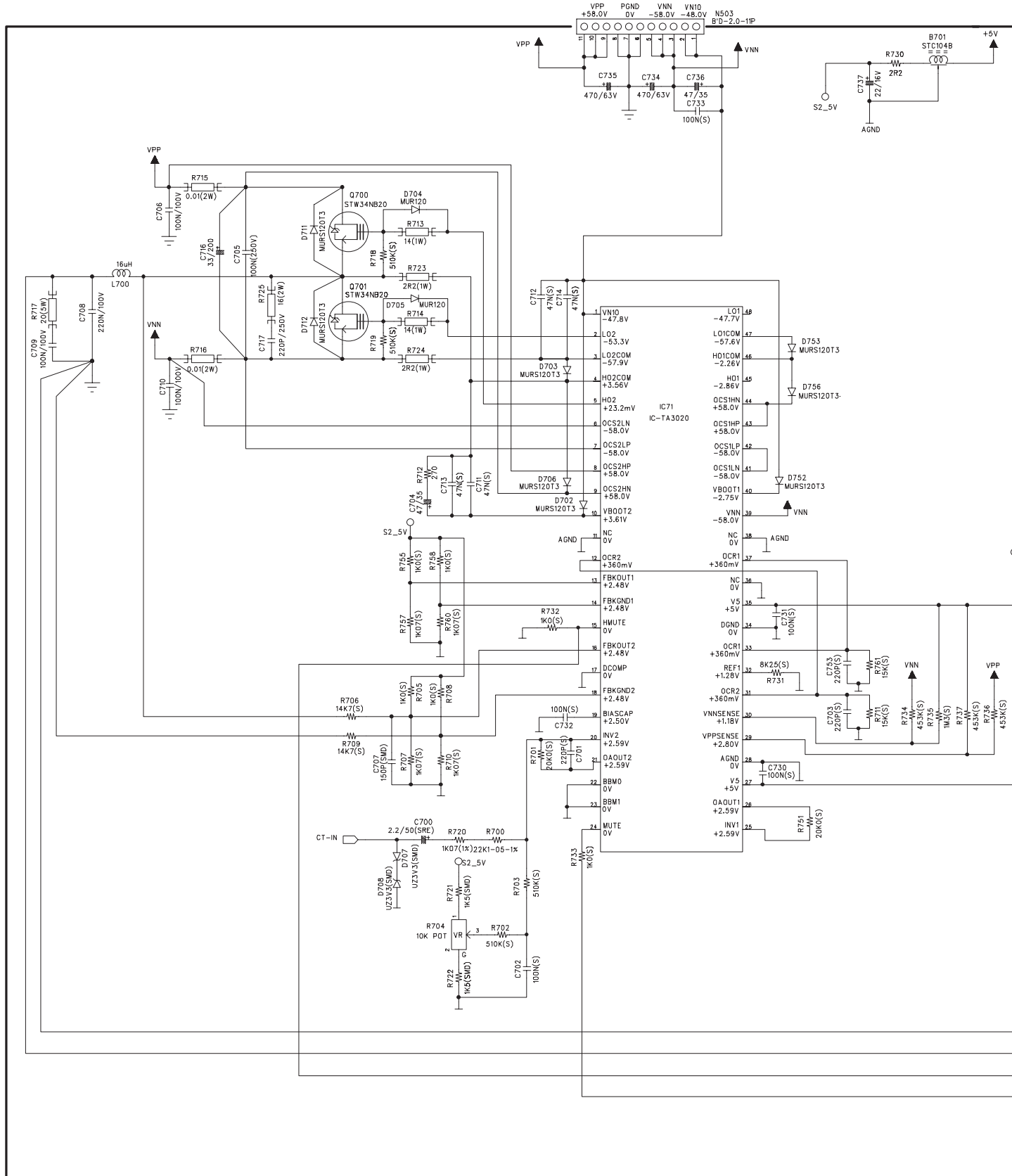

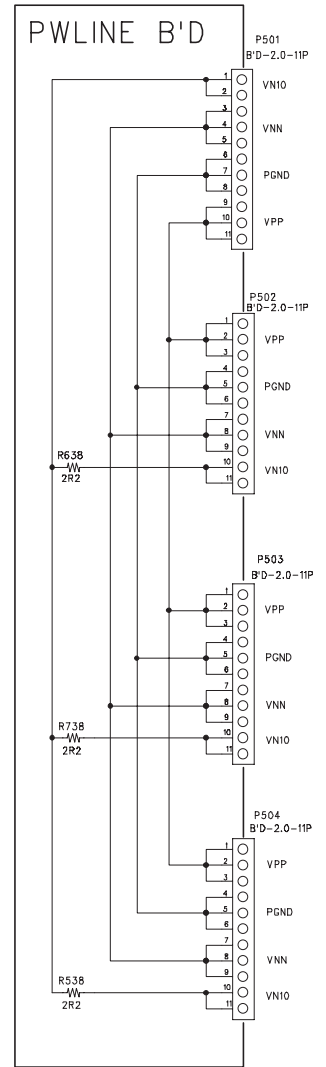
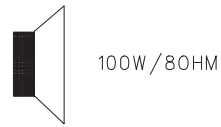
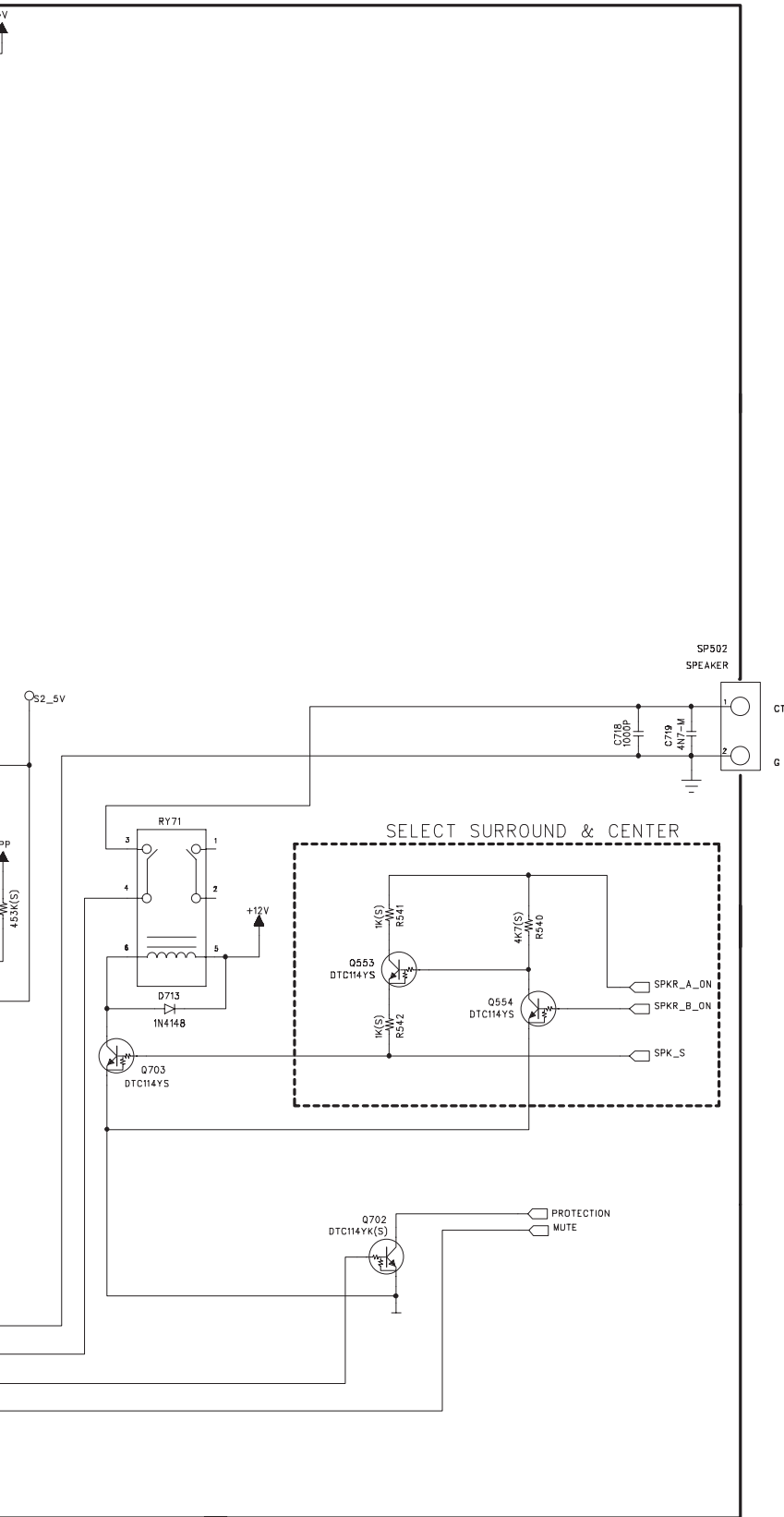

A

B

C

D

SCHEMATIC DIAGRAMS-9

POWER AMPLIFIER SECTION(SL/SR)

1

2

3

4

5

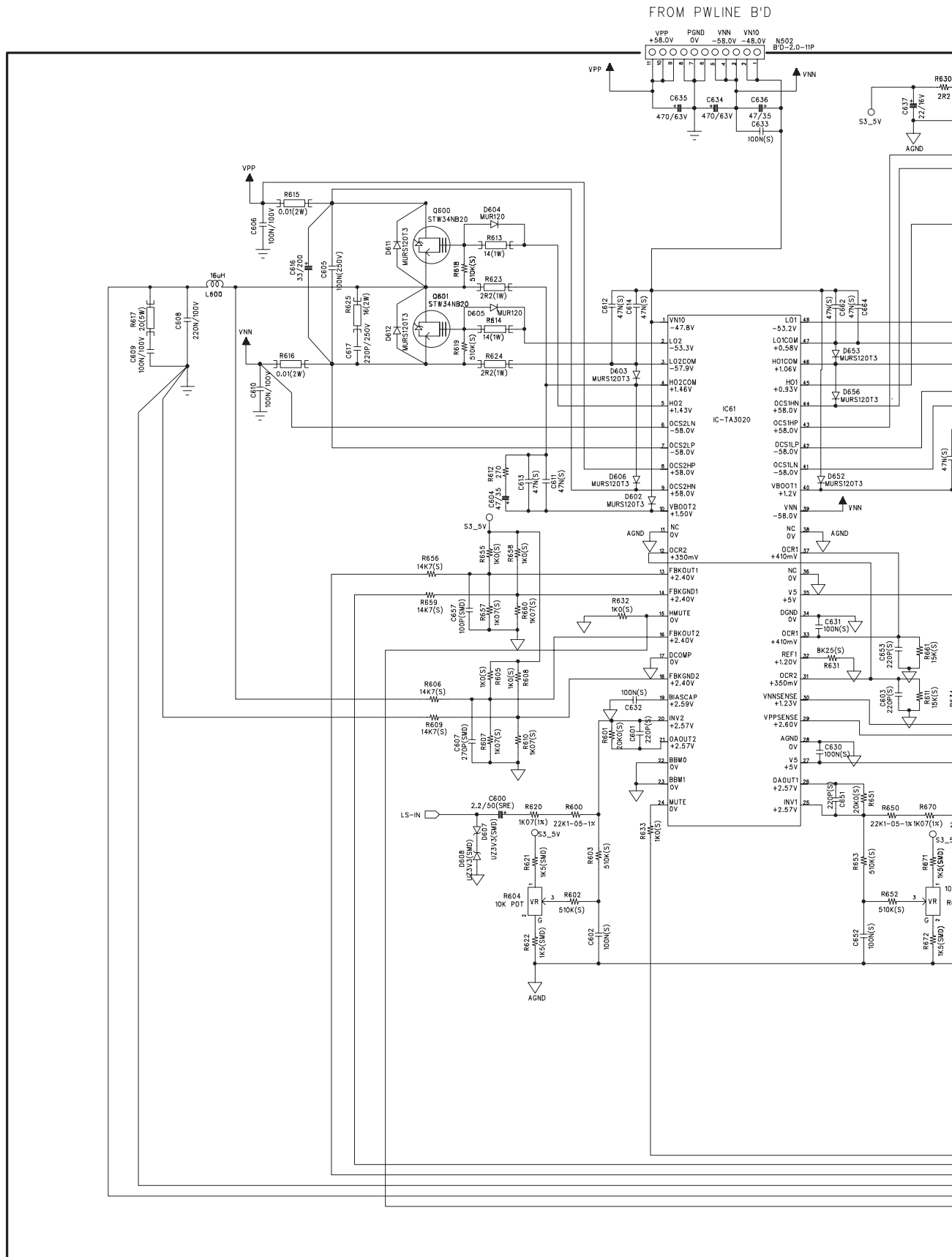

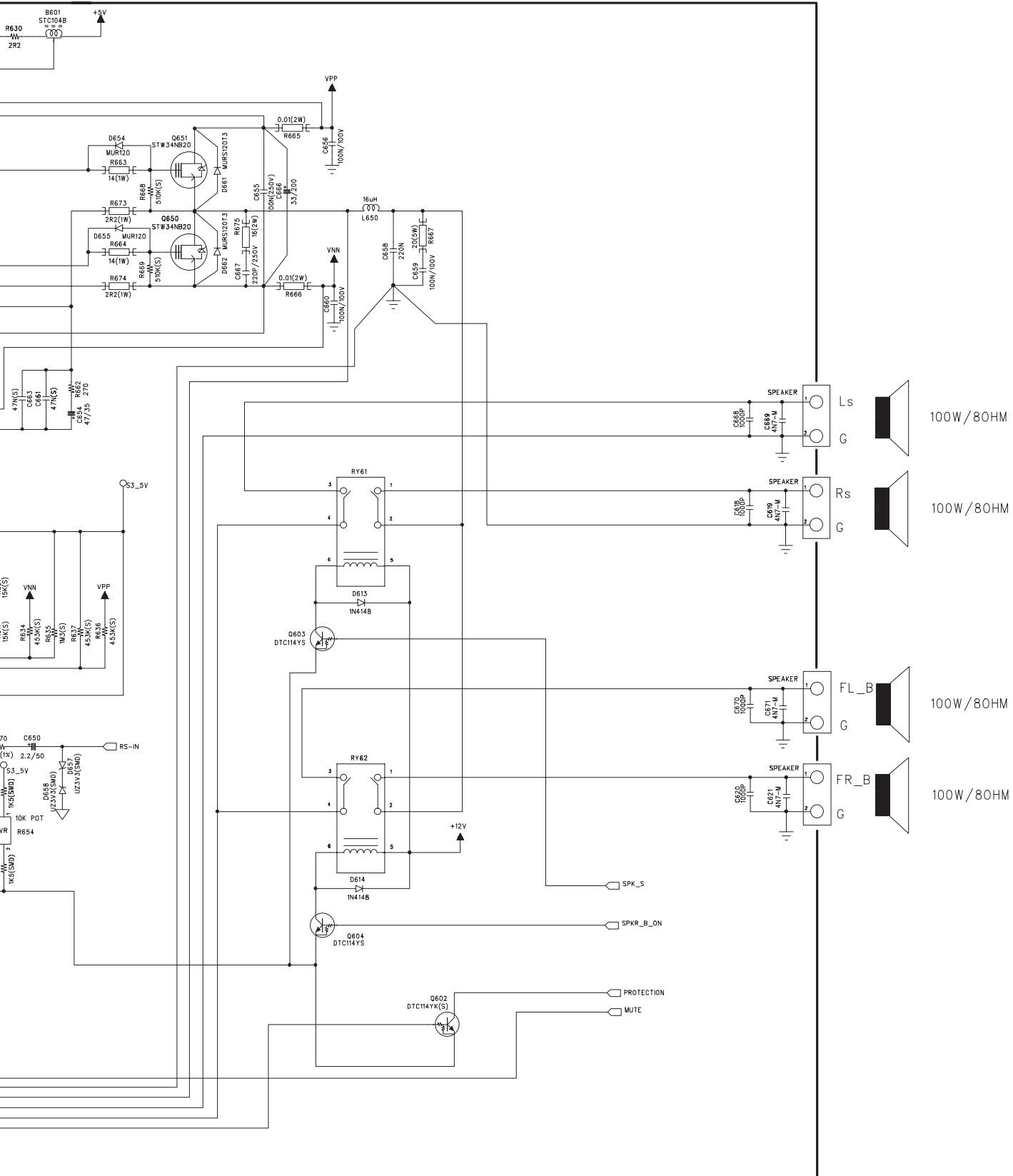

A B C D E

SCHEMATIC DIAGRAMS-10

SMPS(Switching power supply)

1

2

3

4

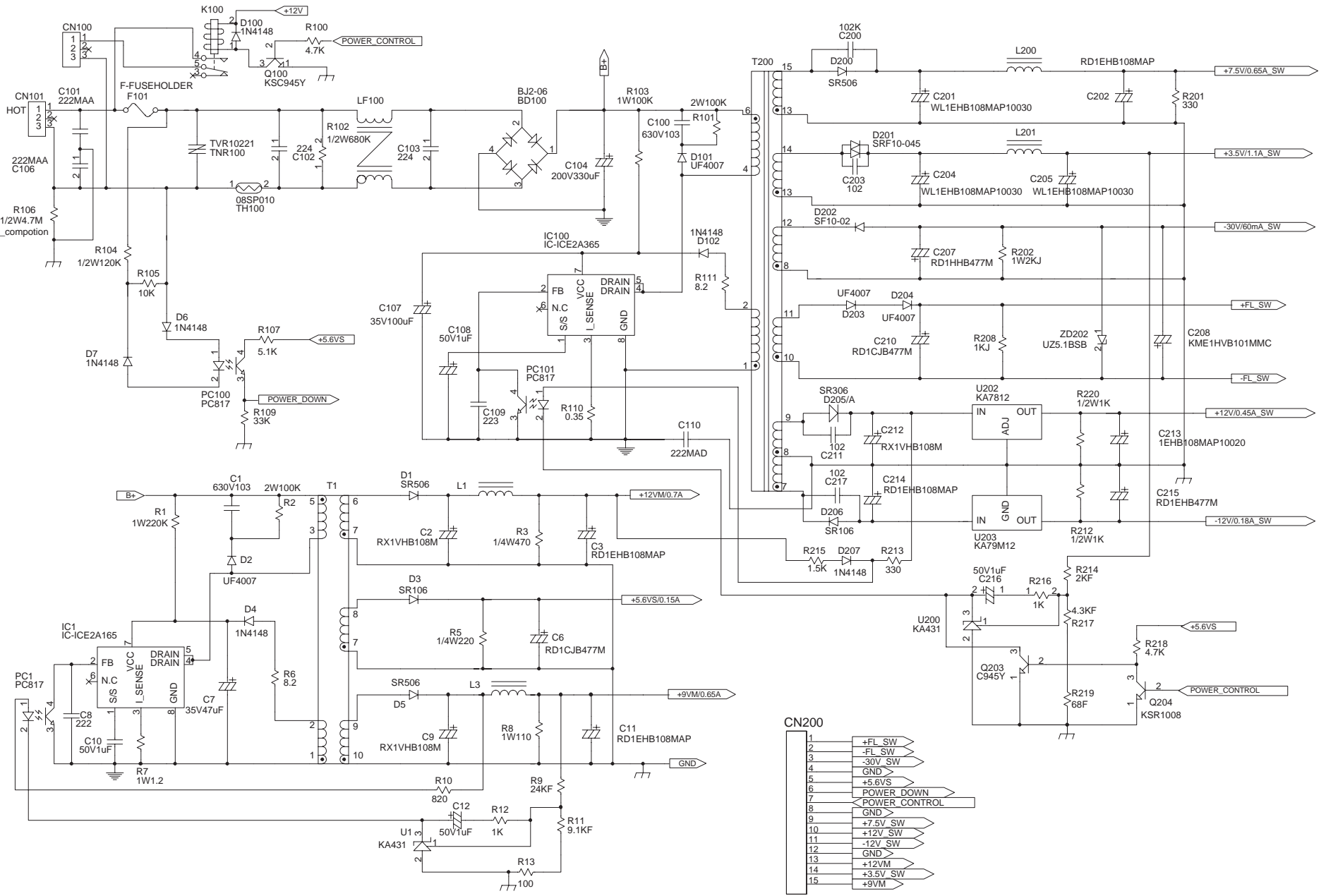

PC BOARD CONNECTION DIAGRAM

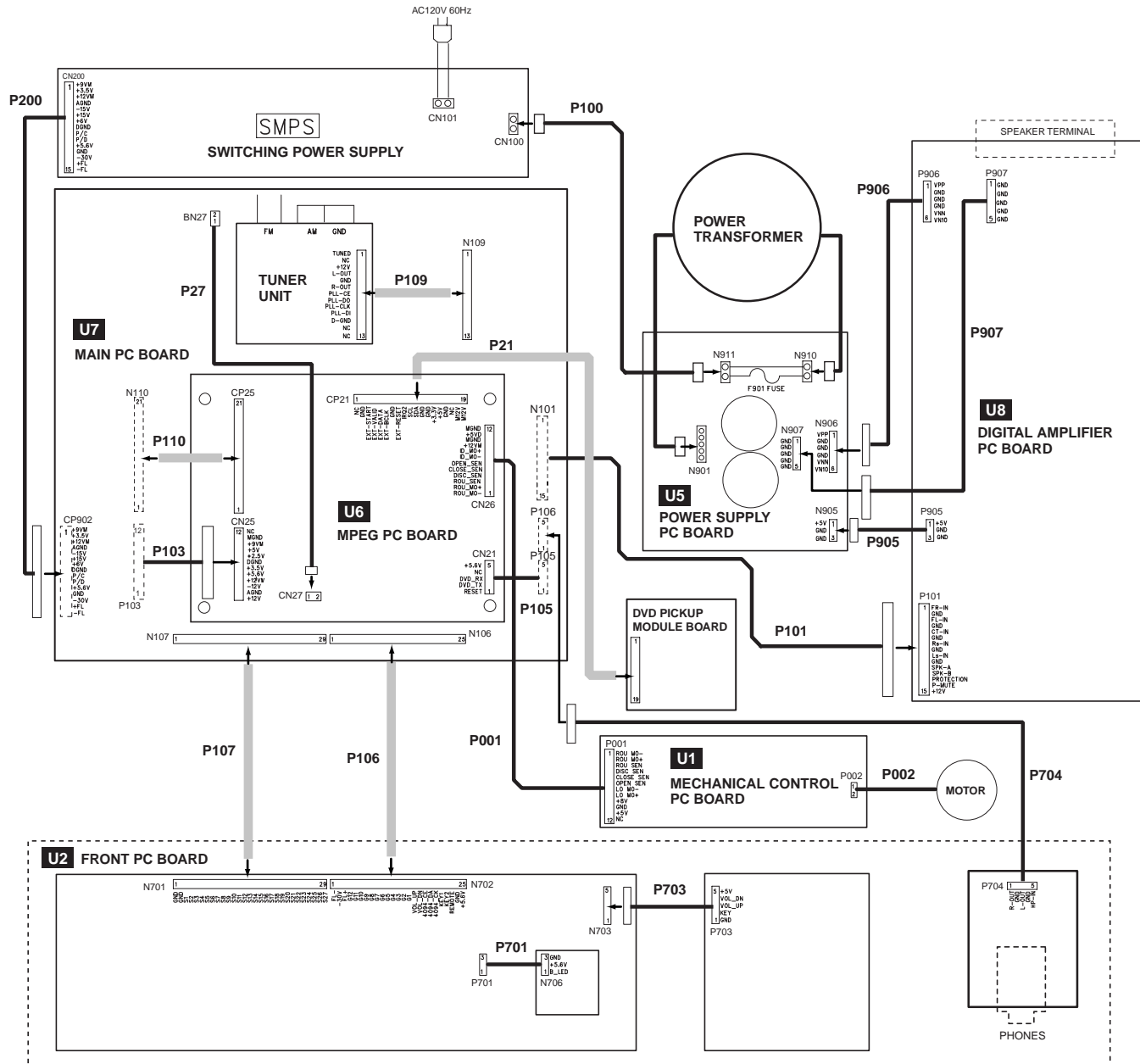

FFC SPECIFICATION LIST

REF NO.	PART NO.
P109	13PIN/P1.25MM/110MM/SHIELD
P110	21PIN/P1.25MM/50MM
P21	19PIN/P1.25MM/350MM/SHIELD
P106	25PIN/P1.25MM/250MM
P107	29PIN/P1.25MM/250MM/SHIELD

Refer to the Exploded view parts list.

WIRE SPECIFICATION LIST

REF NO.	PART NO.
P200	7.92MM/2PIN/200MM
P100	7.92MM/2PIN/200MM
P906	3.96MM/6PIN/300MM
P907	3.96MM/5PIN/300MM
P905	2.0MM/3PIN/210MM
P101	2.0MM/15PIN/450MM/SHIELD
P704	2.0MM/5PIN/400MM/SHIELD
P001	2.0MM/12PIN/550MM
P703	2.0MM/5PIN/60MM
P701	2.0MM/3PIN/80MM
P105	2.0MM/5PIN/60MM
P103	2.5MM/12PIN/60MM
P002	2.0MM/2PIN/150MM
P27	2.0MM/2PIN/200MM/SHIELD

Refer to the PC board parts list.

MICROPROCESSOR CONNECTION DIAGRAM

IC26: CXP82860-XXXQ

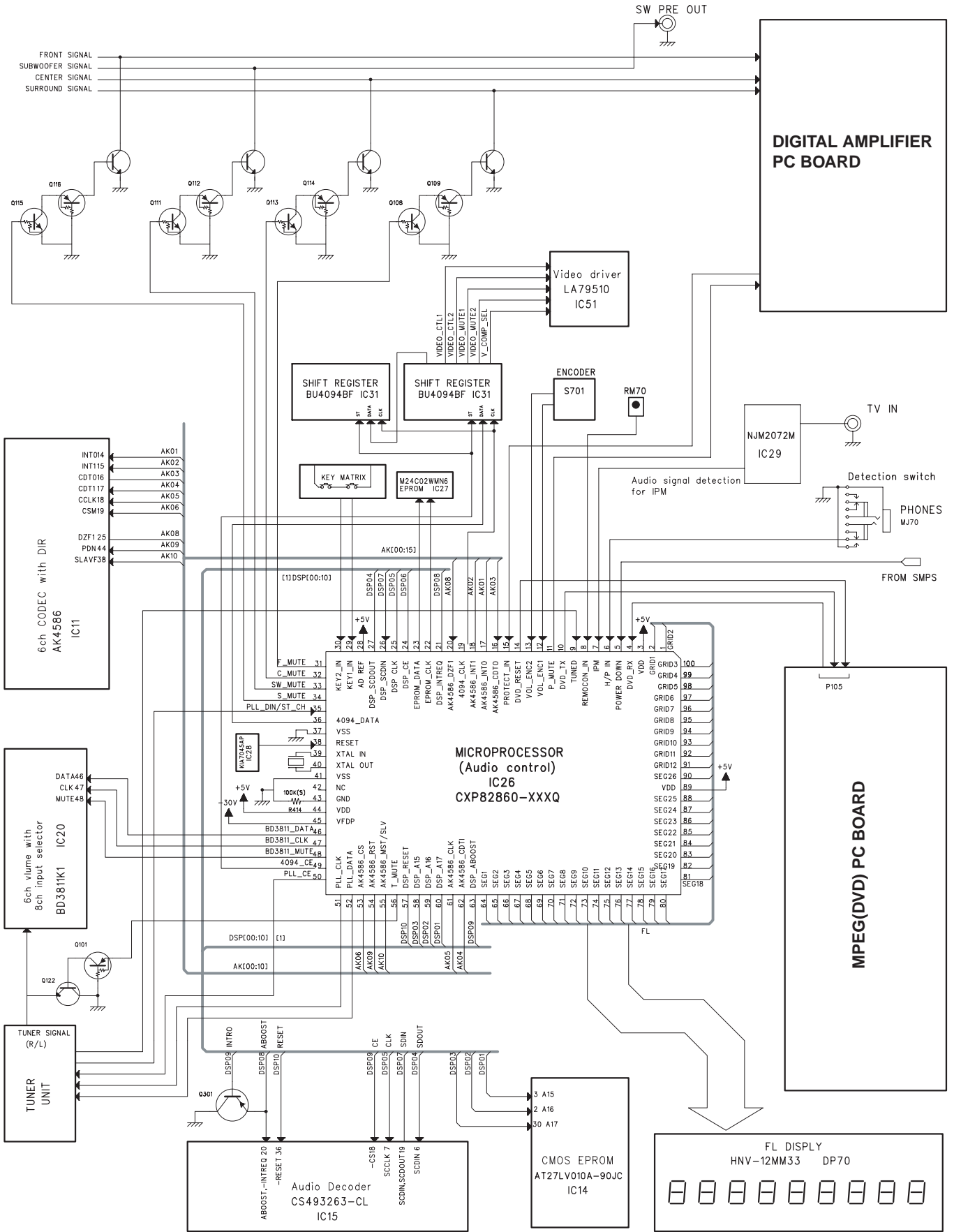

MICROPROCESSOR TERMINAL DESCRIPTION-1

IC26 : CXP82860-XXXQ

PIN NO.	PIN NAME	I/O	LOGIC	FUNCTION
1	GRID02	O	H	Output pin of grid2 for VFD unit
2	GRID01	O	H	Output pin of grid1 for VFD unit
3	VDD	-	-	Power supply pin
4	DVD_RX	I	L	Input pin of detection signal from AC power for system on/off
5	POWER_DOWN	I	L	Input pin of detection signal from insert state of headphone plug
6	H/P_IN	I	H	Input pin for IPM(intelligent power management) fuction
7	IPM	I	H	Input pin of RI(system control signal)
8	REMOCON_IN	I	L	Input pin of tuned signal from tuner unit.
9	TUNED	I	L	Output pin of serial data signal to mpeg IC in dvd b'd
10	DVD_TX	O	L	Output pin of muting signal for d-amp supply.
11	P_MUTE	O	L	Input pin of control signal for volume.
12	VOL_ENC1	I	L	Input pin of control signal for volume.
13	VOL_ENC2	I	L	Output pin of reset signal for dvd b'd.
14	DVD_RESET	O	L	Input pin of detection signal from d-amp part.
15	PROTECT_IN	I	H	Input pin of serial control data signal from AK4586
16	AK4586_CDTO	I	H	Output pin of interruption signal to AK4586
17	AK4586_INT0	O	H	Output pin of interruption signal to AK4586
18	AK4586_INT1	O	CLK	Output pin of serial clock for 4094
19	4094_CLK	O	H	Input pin of zero input detection signal to AK4586
20	AK4586_DZF1	I	H	Output pin of interrupt request signal to CS49326
21	DSP_INTREQ	O	CLK	Output pin of serial clock to EPROM
22	EPROM_CLK	O	L	Output pin of serial data to EPROM
23	EPROM_DATA	O	H	Output pin of serial latch for CS49326
24	DSP_CE	O	CLK	Output pin of serial clock to CS49326
25	DSP_CLK	O	H	Input pin of serial control data signal from CS49326
26	DSP_SCDIN	I	H	Output pin of serial control data signal to CS49326
27	DSP_SCDOUT	O	-	Power supply pin for A/D converter
28	AD_REF	-	A/D	Input pin of A/D key signal
29	KEY1_IN	I	A/D	Input pin of A/D key signal
30	KEY2_IN	I	L	Output pin of muting signal for Front R & Front L ch
31	F_MUTE	O	L	Output pin of muting signal for Center ch
32	C_MUTE	O	L	Output pin of muting signal for subwoofer ch
33	SW_MUTE	O	L	Output pin of muting signal for Rear R & Rear L ch
34	S_MUTE	O	H	Input pin of serial data for PLL IC of tuner
35	PLL_DIN/ST_CH	I/O	H	Output pin of serial data for 4094
36	4094_DATA	O	-	Ground pin
37	VSS	-	L	Input pin for system reset
38	RESET	I	-	Connect to ceramic oscillator
39	XTAL_IN	-	-	Connect to ceramic oscillator
40	XTAL_OUT	-	-	Ground pin
41	VSS	-	-	No used
42	NU	-	-	Ground pin
43	GND	-	-	Power supply pin
44	VDD	-	-	Power supply pin for VFD
45	VFDP	-	H	Output pin of serial data for BD3811(audio input IC)
46	BD3811_DATA	O	CLK	Output pin of serial clock for BD3811(audio input IC)
47	BD3811_CLK	O	H	Output pin of muting signal for BD3811(audio input IC)
48	BD3811_MUTE	O	H	Output pin of serial latch for BU4094
49	4094_CE	O	H	Output pin of serial latch for PLL IC of tuner unit
50	PLL_CE	O	L	Input pin of serial data signal to mpeg IC in dvd b'd

MICROPROCESSOR TERMINAL DESCRIPTION-2

IC26 : CXP82860-XXXQ

PIN NO.	PIN NAME	I/O	LOGIC	FUNCTION
51	PLL_CLK	O	H	Output pin of serial clock for PLL IC of tuner unit
52	PLL_DATA	O	H	Output pin of serial data for PLL IC of tuner unit
53	AK4586_CS	O	H	Output pin of chip select signal to AK4586.
54	AK4586_RST	O	H	Output pin of reset signal to AK4586.
55	AK4586_MST/SLV	O	H	Output pin of master & slave select signal to AK4586
56	T_MUTE	O	H	Output pin for mute to tuner unit
57	DSP_RESET	O	L	Output pin of reset signal to CS49326
58	DSP_A15	O	H	Output pin signal for select of DSP boot ROM address 15
59	DSP_A16	O	H	Output pin signal for select of DSP boot ROM address 16
60	DSP_A17	O	H	Output pin signal for select of DSP boot ROM address 17
61	AK4586_CLK	O	CLK	Output pin of serial clock to AK4586
62	AK4586_CDTI	O	H	Output pin of serial control data to AK4586.
63	DSP_ABOOST	O	H	Output pin of automatic boot signal to CS49326
64	SEG1	O	H	Output pin of segment01 for VFD unit
65	SEG2	O	H	Output pin of segment02 for VFD unit
66	SEG3	O	H	Output pin of segment03 for VFD unit
67	SEG4	O	H	Output pin of segment04 for VFD unit
68	SEG5	O	H	Output pin of segment05 for VFD unit
69	SEG6	O	H	Output pin of segment06 for VFD unit
70	SEG7	O	H	Output pin of segment07 for VFD unit
71	SEG8	O	H	Output pin of segment08 for VFD unit
72	SEG9	O	H	Output pin of segment09 for VFD unit
73	SEG10	O	H	Output pin of segment10 for VFD unit
74	SEG11	O	H	Output pin of segment11 for VFD unit
75	SEG12	O	H	Output pin of segment12 for VFD unit
76	SEG13	O	H	Output pin of segment13 for VFD unit
77	SEG14	O	H	Output pin of segment14 for VFD unit
78	SEG15	O	H	Output pin of segment15 for VFD unit
79	SEG16	O	H	Output pin of segment16 for VFD unit
80	SEG17	O	H	Output pin of segment17 for VFD unit
81	SEG18	O	H	Output pin of segment18 for VFD unit
82	SEG19	O	H	Output pin of segment19 for VFD unit
83	SEG20	O	H	Output pin of segment20 for VFD unit
84	SEG21	O	H	Output pin of segment21 for VFD unit
85	SEG22	O	H	Output pin of segment22 for VFD unit
86	SEG23	O	H	Output pin of segment23 for VFD unit
87	SEG24	O	H	Output pin of segment24 for VFD unit
88	SEG25	O	H	Output pin of segment25 for VFD unit
89	VDD	-	-	Power supply pin
90	SEG26	O	H	Output pin of segment26 for VFD unit
91	GRID12	O	H	Output pin of grid12 for VFD unit
92	GRID11	O	H	Output pin of grid11 for VFD unit
93	GRID10	O	H	Output pin of grid10 for VFD unit
94	GRID9	O	H	Output pin of grid09 for VFD unit
95	GRID8	O	H	Output pin of grid08 for VFD unit
96	GRID7	O	H	Output pin of grid07 for VFD unit
97	GRID6	O	H	Output pin of grid06 for VFD unit
98	GRID5	O	H	Output pin of grid05 for VFD unit
99	GRID4	O	H	Output pin of grid04 for VFD unit
100	GRID3	O	H	Output pin of grid03 for VFD unit

DISASSEMBLING PROCEDURES (DVD MECHANISM) -1

NOTES IN RE-ASSEMBLING PROCEDURES OF DWG ASY CAROUSEL

VIEW "Z" Montage of the ASY DRAWER to ASSY BASE

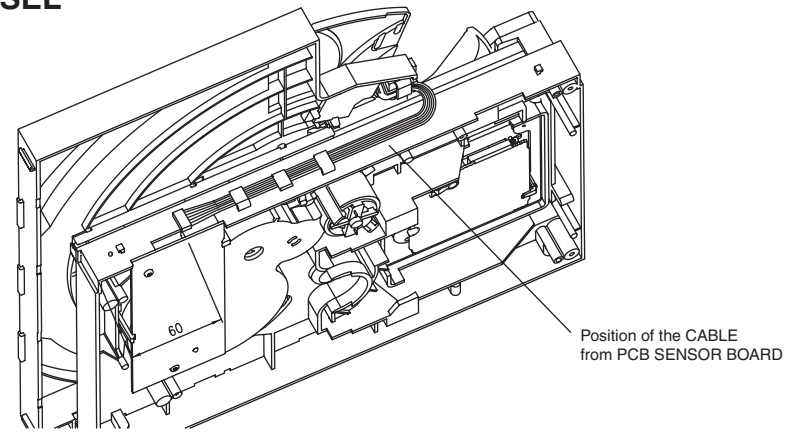
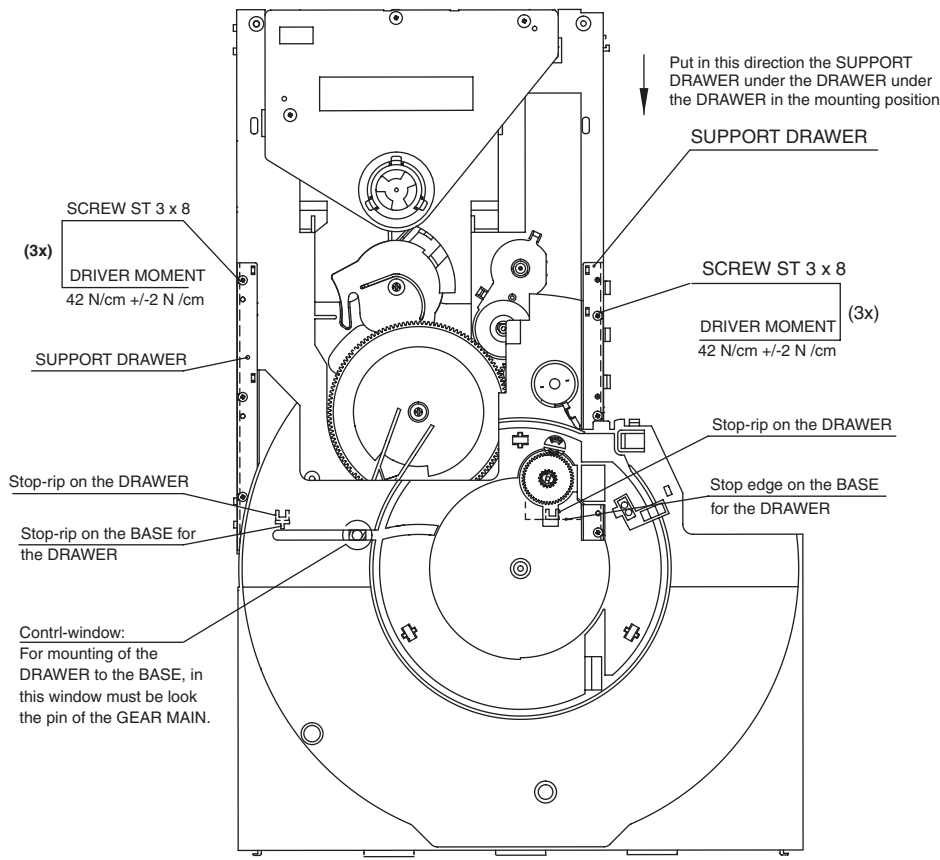

Montage of the PLATTER

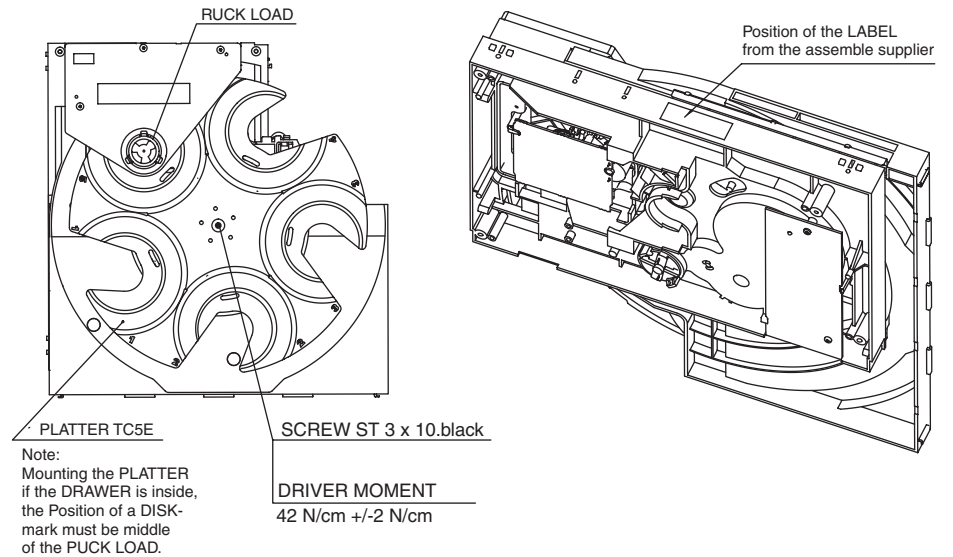

VIEW "Z"

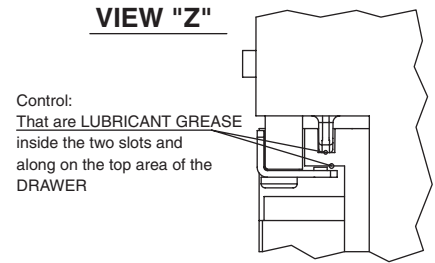

DISASSEMBLING PROCEDURES (DVD MECHANISM)-2
NOTE IN RE-ASSEMBLING PROCEDURES OF DWG ASY BASE

Montage of CAM LIFTER

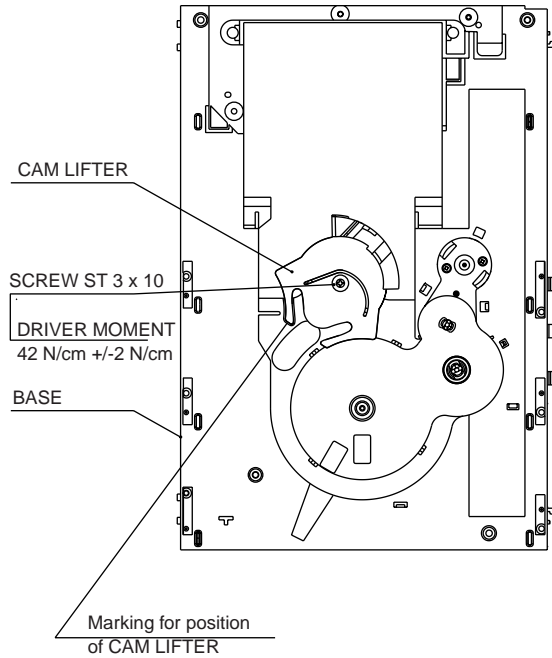

Montage of GEAR MAIN

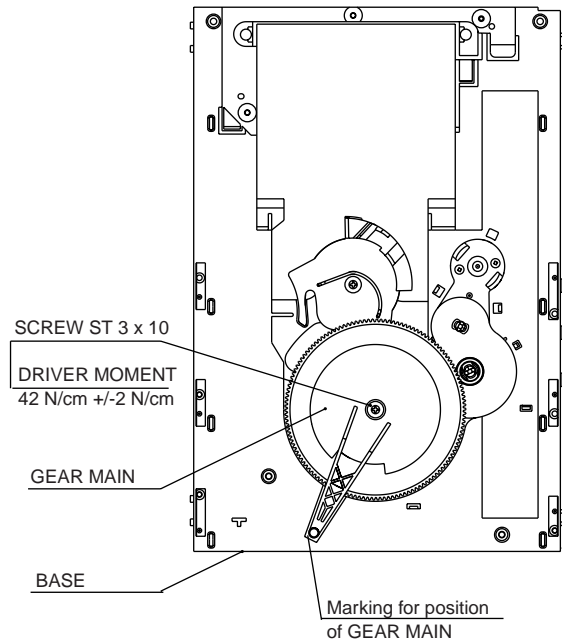

Montage of RUBBER BELT DRIVE

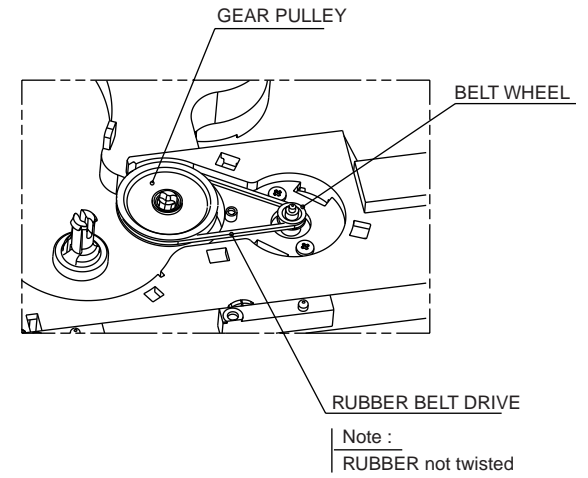

Montage of BELT WHEEL 2

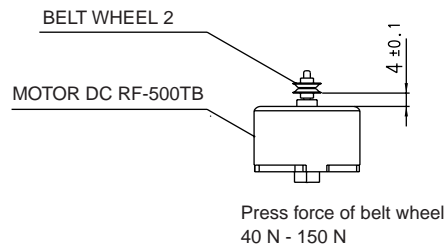

Montage of MOTOR

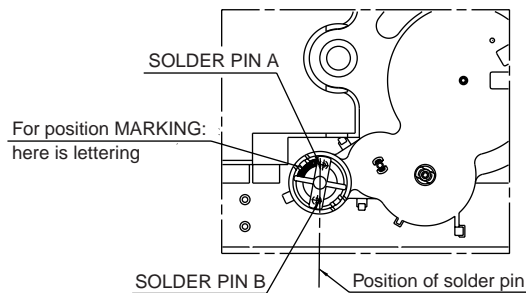

Montage of PUCK LOAD

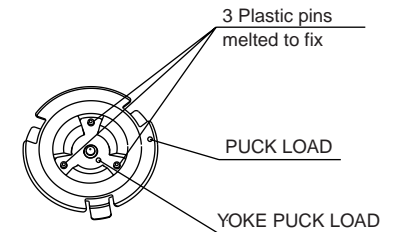

DISASSEMBLING PROCEDURES (DVD MECHANISM)-3

NOTES IN RE-ASSEMBLING PROCEDURES OF DWG ASY DRAWER

Montage of MOTOR

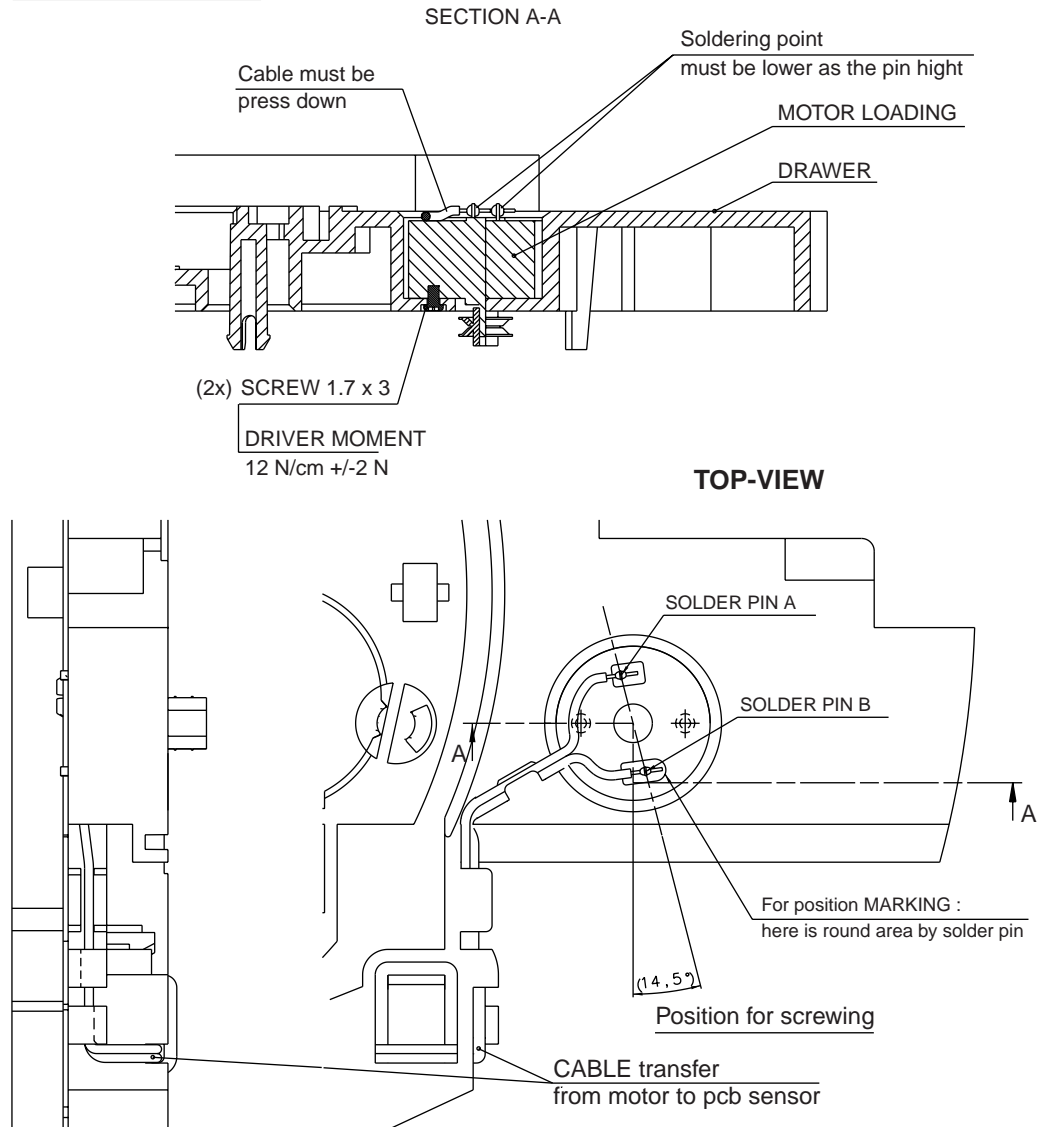

Montage of BELT WHEEL 2

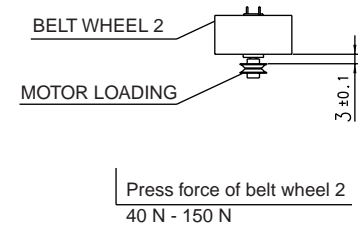

Montage of RUBBER BELT DRIVE

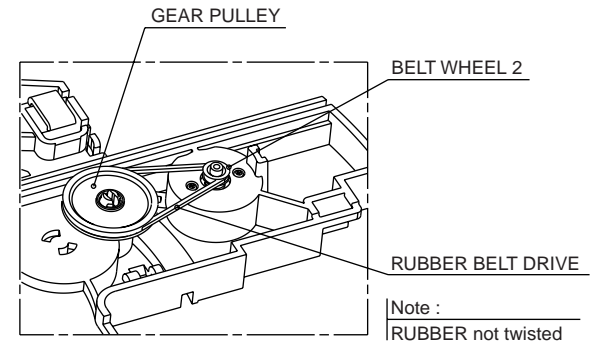

ADJUSTMENT PROCEDURES-1

DC OFFSET ADJUSTMENT

1. ADJUSTMENT POINT

R654
(SURROUND R)

R604
(SURROUND L)

R704
(CENTER)

R554
(FRONT R)

R504
(FRONT L)

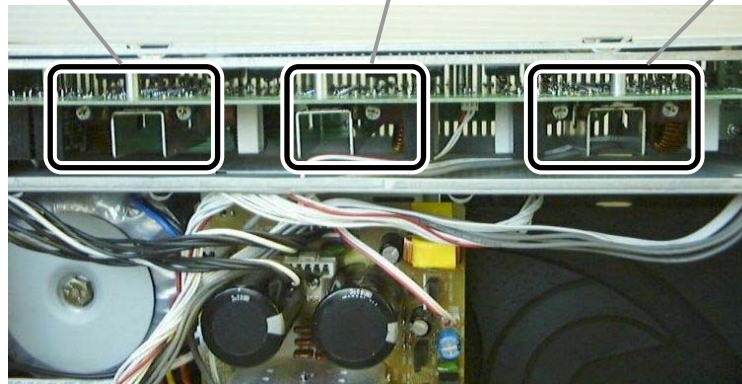
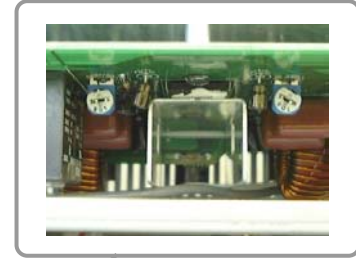
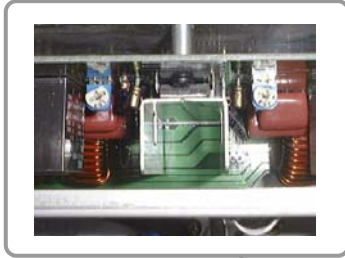

2. CHECK POINT

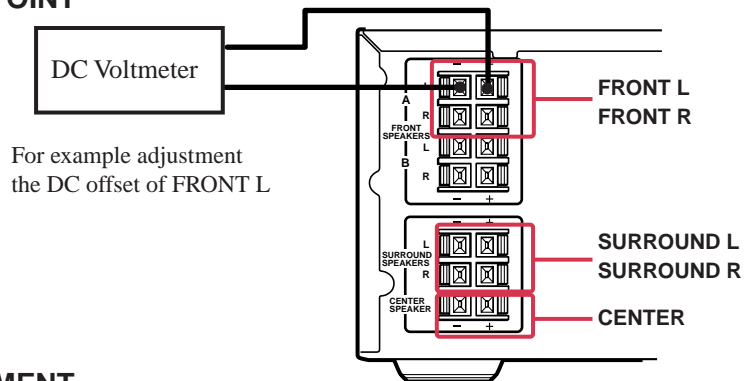

3. ADJUSTMENT

[Note]

No load and No signal

1. Remove the top cover.
2. Power on the unit.
3. Connect the DC voltmeter to FRONT L SPEAKER terminals.
4. Adjustment trimming resistor R504 so that reading of DC voltmeter becomes -15 to +15mV.
5. Connect the DC voltmeter to FRONT R SPEAKER terminals.
6. Adjustment trimming resistor R554 so that reading of DC voltmeter becomes -15 to +15mV.
7. Connect the DC voltmeter to CENTER SPEAKER terminals.
8. Adjustment trimming resistor R704 so that reading of DC voltmeter becomes -15 to +15mV.
9. Connect the DC voltmeter to SURROUND SPEAKER L terminals.
10. Adjustment trimming resistor R604 so that reading of DC voltmeter becomes -15 to +15mV.
11. Connect the DC voltmeter to SURROUND SPEAKER R terminals.
12. Adjustment trimming resistor R654 so that reading of DC voltmeter becomes -15 to +15mV.
13. Disconnect the DC voltmeter from SURROUND SPEAKER R terminals.
14. Attached the top cover.

PACKING PROCEDURES

1. SET PACKING

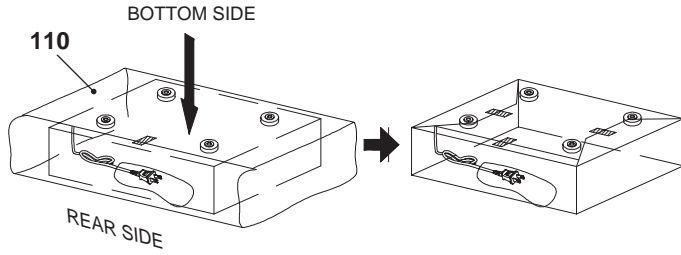

2. SET IN CUSHION AND AC COARD

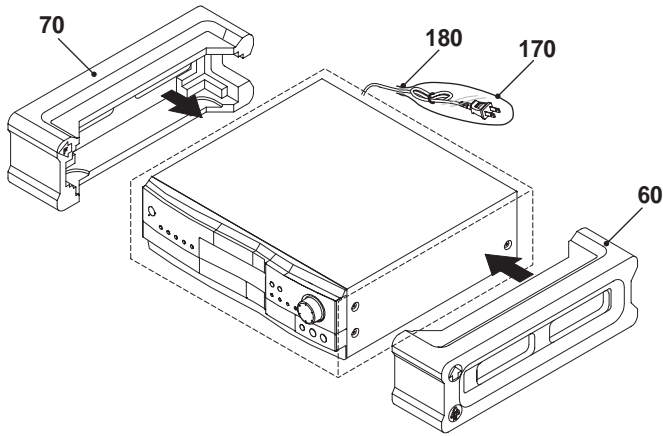
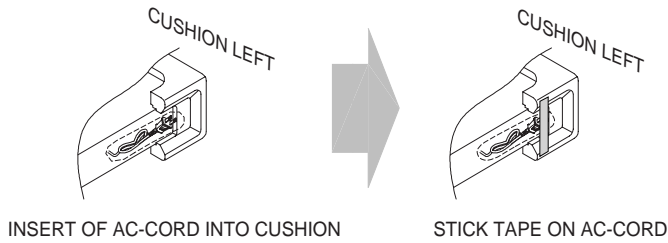

3. SET IN CARTON

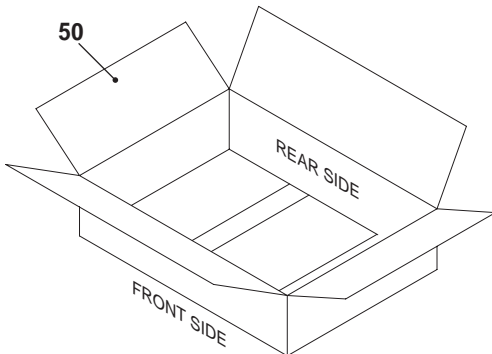

4. PACK ACCESSORIES into the POLY BAG and POSITION THIS on the UNIT

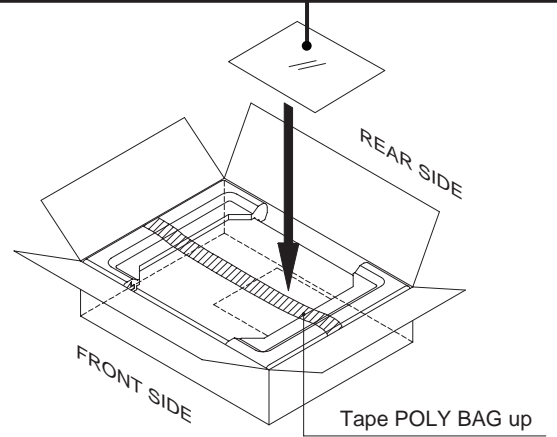
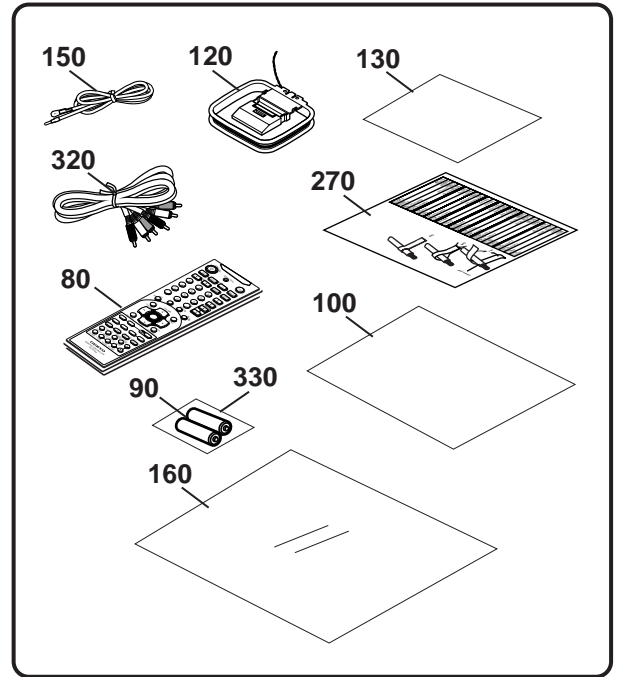

5. LABEL FOR CARTON

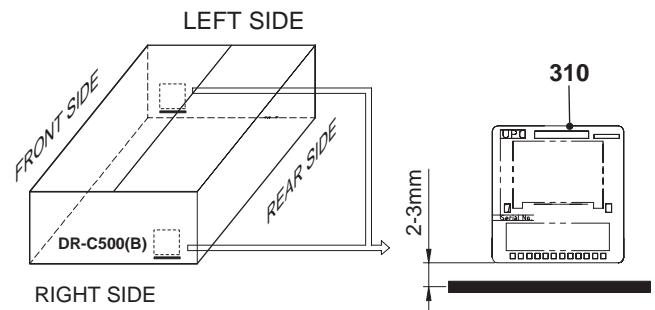

EXPLODED VIEW PARTS LIST

[NOTE]

B: BLACK MODEL ONLY

S: SILVER MODEL ONLY

REF NO.	PART NAME	DESCRIPTION	PARTS NO.
50	FRONT PANEL, BLACK	BLACK	55465620
50	FRONT PANEL, SILVER	SILVER	55466820
60	FACET, STANDBY	STANDBY	55186710
70	KNOB BASE, DISC NUMBER	5KEY	55464220
80	HOLDER, ILLUMINATION		55464520
90	KNOB BASE, STANDBY/ON	1KEY	55464420
100	KNOB BASE, PLAY	3KEY	55464120
110	KNOB BASE, INPUT BLACK	6KEY	55464320
110	KNOB BASE, INPUT SILVER		55466920
120	KNOB CAP, INPUT-A		55464720
130	KNOB CAP, INPUT-B		55464820
140	KNOB CAP, OPEN		55464920
150	KNOB CAP, PLAY		55465020
160	KNOB CAP, STOP		55465220
170	KNOB CAP, STANDBY		55465120
180	KNOB CAP, DISC NUMBER		55483350
190	FACET ILLUMINATION		55465420
200	CLEAR PLATE		55465720
210	DOOR TRAY, BLACK		55465320
210	DOOR TRAY, SILVER		55467720
220	KNOB, MASTER VOLUME, BLACK		55465520
220	KNOB, MASTER VOLUME, SILVER		55467020
230	CHASSIS		55466120
240	TOP COVER, BLACK		5546672A
240	TOP COVER, SILVER		5546752A
250	REAR PANEL		5546652A
260	BRACKET, FRONT		55466020
270	BRACKET, MAIN		55466320
280	BRACKET, AMP		55466220
290	HEATSINK		55466420
300	BRACKET, MPEG PCBA		55465820
310	BRACKET, MPEG PCBB		55465920
320	POWER SUPPLY CORD	0.75mm2 2200mm BK US LMPS0242-0	55190780
330	BUSHING	#2271	27300750
350	TAPPING SCREW	3TTB+8B	838130088
360	TAPPING SCREW	3TTB+6B	838130068
370	SPECIAL SCREW 4 x 8	4mm x 8mm ROUND END TYPE	55215980
380	TAPPING SCREW	3TTW+8B	55127120
400	TUNER UNIT	KST-MB011MA0-70 OEM US/	55451470
410	PLATE, BOTTOM		55477040
470	LEG	ROUND 12.5mm 50mm	55125120
480	LEG RUBBER	3.0mm 25.0mm JIS 60 Y DIA	55141370
510	POWER TRANSFORMER, 120V	120V	55506070
520	POWER SUPPLY UNIT		55506080
540	SCREW 3MM 6MM MACHINE	3mm x 6mm	55164810
550	MACHINE SCREW 3 x 14	3mm x 14mm	20349160
560	TAPPING SCREW, 3 x 6 BLACK		55546030
560	TAPPING SCREW, 3 x 6 SILVER	3mm x 6mm SILVER	55546020
565	TAPPING SCREW, 3 x 10 BLACK	3mm x 10mm BLACK	55135460
570	TAPPING SCREW 3 x 6	3mm x 6mm ROUND END TYPE	55552700
580	WASHER 3 - 8 -0.5	3.0mm - 8.0mm -0.5mm N/A 00 0 0	20523540
590	GUIDE, CNT		55552680
610	CORE	34.5 x 21 x 12 K-150	55148840
620	SHIELD PLATE	71TSFK-13-0.6-20-13	55588060
630	CUSHION	AC 15 x 15 x 15	55598150
640	CUSHION	99 x 10 x 0.5	55584250
650	PLATE	30 x 8 x 1.0 (PC-1.0T)	55602400
660	PLATE	38 x 120 x 0.3T BK NON-METAL	55190770
250	CUSHION FL	20mm x 12mm x 5mm	55468440
670	SHIELD PLATE, SPEAKER		55466620
M	DVD MECHANISM KIT	5E/TVM503R6	10784020
U1	MECHA CONTROL PC BOARD ASSY		55463320
U2	FRONT PC BOARD ASSY		55461520
U5	POWER SUPPLY PC BOARD ASSY		55461620
U6	MPEG PC BOARD ASSY		55469560
U7	MAIN PC BOARD ASSY		55461720
U8	DIGITAL AMPLIFIER ASSY		55461820
P109	FLAT CABLE 13P110	13pin 1.25mm Pitch 110mm Shield type	55550820NR
P110	FLAT CABLE 21P50	21pin 1.25mm Pitch 50mm	55489290NR
P21	FLAT CABLE 19P350	19pin 1.25mm Pitch 350mm Shield type	55550810NR
P106	FLAT CABLE 25P250	25pin 1.25mm Pitch 250mm	55489250NR
P107	FLAT CABLE 29P250	29pin 1.25mm Pitch 250mm Shield type	55590850NR
P100	WIER SOCKET ASSY	2P 200mm	55553910NR
F901	FUSE 6.3A/250V	DETIMELG	55126930
F101	FUSE 3A/125V	SLWBL	55639760

EXPLODED VIEW PARTS LIST OF DVD MECHANISM

DR-C500

[NOTE]

REF NO.	PART NAME	DESCRIPTION	PARTS NO.	REMARK
Z1: DWG ASSY CAROUSEL				
M1	SCREW-ST 3 x 10 BLACK		20692310	
M2	PLATTER TC5E		10746630	
M3	SCREW-ST 3 x 8		20349380	
M4	SUPPORT DRAWER		10746590	
Z5	DWG ASY DRAWER TC5E		10767370	
Z6	DWG ASY BASE TC5E		10767360	
M7	SCREW WASHER		10520320	
M8	CUSHON 8		10741230	
M9	DVD MODULE TVM503R6		10779450	
M10	BRACKET TC5E		10746530	
M11	SCREW SPEC 3 x 10		10752960	
Z5: DWG ASSY DRAWER				
The parts which constitute DWG ASSY DRAWER.				
M21	PUCK LOAD		10745820	
M22	YOKE PUCK LOAD		10698670	
M23	SCREW ST 3 x 8		20349380	
M24	HOLDER PUCK DVD TC5E		10746580	
M25	CAM LIFTER TC5E		10746550	
M26	SCREW ST 3 x 10		20692300	
M27	GEAR MAIN TC5E		10746540	
M28	COVER GEAR TC5E		10746560	
M29	RUBBER BELT DRIVE		55073350	
M30	GEAR PULLEY		10707950	
M31	GEAR DRIVE		10707940	
M32	SCREW 2.6 x 4		20349530	
M33	BASE TC5E		10746520	
M34	RUBBER SPACER		20689440	
M35	MOTOR ASSY DC		---	
Z6: DWG ASSY BASE				
The parts which constitute DWG ASSY BASE				
M41	RUBBER ROLLER		20712120	
M42	ROLLER HUB		10707920	
M43	COVER DRAWER		10746650	
M44	MOTOR ASSY LOADING		---	
M46	GEAR PLATTER		10746640	
M47	DRAWER		10746620	
M48	SCREW 1.7 x 3		10703470	
M49	ASY PCB SENSOR		10658770	
M50	GEAR PULLEY		10707950	
M51	RUBBER BELT DRIVE		55073350	

PC BOARD PARTS LIST

DR-C500

[NOTES]

U1	U1	MECHANISM CONTROL PC BOARD			
U1	REF NO.	NAME	DESCRIPTION	PART NO.	NOTES
U1	C001	CERA C	22P0F+5%-5%50V	80434590	
U1	C002	CERA C	100N0F+80%-20%25V	20246470	
U1	C003	CERA C	100N0F+80%-20%25V	20246470	
U1	C004	CERA C	100N0F+80%-20%25V	20246470	
U1	C005	ELECT C	1MIOF+20%16V	55475030	
U1	P001	CONNECTOR AS	12P550MMUL1007	55553930	
U1	P002	CONNECTOR AS	2P150MMUL1007	55183500	
U1	P026	PLUG WAFER	2MM6MARNAT	55123400	
U1	D001	ZENER D	1N5232B5.6V	20414280	
U1	D002	ZENER D	1N5232B5.6V	20414280	
U1	PI01	OPT PARTS	D-PHOTOITR9606	20586840	SENSOR
U1	PI02	OPT PARTS	D-PHOTOITR9606	20586840	SENSOR
U1	IC01	IC	BA6209N	20458950	
U1	IC02	IC	BA6209N	20458950	
U1	L001	COIL	LF39U0H+10%	20265120	
U1	P001	SOCKET AS	12PIN 550M	55553930NR	
U2	U2	FRONT PC BORAD			
U2	REF NO.	NAME	DESCRIPTION	PART NO.	NOTES
U2	C704	ELECT C	CE47U0F+20%16V	20342060	
U2	C706	ELECT C	CE1U0F+20%50V	20251830	
U2	D701	CHIP D	1SS355	20496510	
U2	D703	CHIP D	1SS355	20496510	
U2	D704	ZENER D	UDZS5.1B	55177710	
U2	D705	ZENER D	UDZS5.1B	55177710	
U2	D706	ZENER D	UDZS5.1B	55177710	
U2	D708	LED	LTL-42CB6NBU	55136330	BLUE
U2	D709	LED	LTL-1CHPEB-RD	55129160	RED
U2	D710	LED	LTL-1CHGECF-GN	55179290	GREEN
U2	D711	LED	LTL-1CHGECF-GN	55179290	GREEN
U2	D712	LED	LTL-1CHGECF-GN	55179290	GREEN
U2	D713	LED	LTL-1CHGECF-GN	55179290	GREEN
U2	D714	LED	LTL-1CHGECF-GN	55179290	GREEN
U2	DP70	FL TUBE	DISPLAYHNV-12MM33	55469610	
U2	IC70	IC	BU4094BF	20718660	
U2	S701	ENCODER	SWIROTEC16B24204A55V	55134900	MASTER VOLUME
U2	Q701	C-TR	DTC114YKA	55133180	
U2	Q702	C-TR	DTC114YKA	55133180	
U2	Q703	C-TR	DTC114YKA	55133180	
U2	Q704	C-TR	DTC114YKA	55133180	
U2	Q705	C-TR	DTC114YKA	55133180	
U2	Q706	C-TR	DTC114YKA	55133180	
U2	Q707	C-TR	DTA114YKA	55133190	
U2	RM70	RMOTE SENSOR	NJL63H380A	55156010	
U2	MJ70	PHONES JACK	CKX3-6.35-04BK00	55050690	PHONES
U2	P704	SOCKET AS	5PIN400MM	55553940NR	
U2	P703	SOCKET AS	5PIN60MM	55315990NR	
U2	P701	SOCKET AS	3PIN80MM	55552310NR	
U5	U5	POWER SUPPLY PC BOARD			
U5	REF NO.	NAME	DESCRIPTION	PART NO.	NOTES
U5	C902	CPM C	100N0F+10%250V	55095430	
U5	C903	CPM C	100N0F+10%250V	55095430	
U5	C904	CPM C	100N0F+10%250V	55095430	
U5	C905	CPM C	100N0F+10%250V	55095430	
U5	C906	ELECT C	10MIOF+20%71V	55477130	
U5	C907	ELECT C	10MIOF+20%71V	55477130	
U5	C908	CPM C	100N0F+10%250V	55095430	
U5	C909	CPM C	100N0F+10%250V	55095430	
U5	C918	ELECT C	2MI2F+20%16V	13039870	
U5	C923	ELECT C	470U0F+20%16V	20269140	
U5	C927	CPF C	100N0F+10%50V	20266460	
U5	C929	ELECT C	100U0F+20%100V	10250330	
U5	C930	ELECT C	470U0F+20%25V	20269190	
U5	C936	CPF C	100N0F+10%50V	20266460	
U5	C939	CPF C	100N0F+10%100V	55126120	
U5	C940	CPF C	100N0F+10%100V	55126120	
U5	D901	DIODE	RBV-2506	55470130	
U5	D904	DIODE	W2-04F	55179300	
U5	D909	DIODE	1N5819	15042270	
U5	D914	ZENER D	BZX55B30	20475340	
U5	D915	ZENER D	BZX55B27	20475330	
U5	F910	FUSE	FUSTIM500MI0A250V	55263020	
U5	IC93	IC	KIA7805API	55123960	
U5	IC95	IC	LM2575HVT-ADJ	55470500	
U5	L901	COIL	1M2H+20%	55510490	
U5	Q901	TR	KTC2026Y	21141190	
U5	R911	RESISTOR	RMOF2K2OHM+5%2W	90576610	
U5	R912	RESISTOR	RMOF2K2OHM+5%2W	90576610	

U6	U6	MPEG PC BOARD			
U6	REF NO.	NAME	DESCRIPTION	PART NO.	NOTES
U6	C101	ELECT C	CE100U0F+20%10V	20268940	
U6	C103	ELECT C	CE100U0F+20%10V	20268940	
U6	C106	ELECT C	CE22U0F+20%16V	20251930	
U6	C10B	ELECT C	CE10U0F+20%16V	15002130	
U6	C10G	ELECT C	CE10U0F+20%16V	15002130	
U6	C10R	ELECT C	CE10U0F+20%16V	15002130	
U6	C115	ELECT C	CE100U0F+20%16V	20269020	
U6	C117	ELECT C	CE100U0F+20%16V	20269020	
U6	C11B	ELECT C	CE10U0F+20%16V	15002130	
U6	C11G	ELECT C	CE10U0F+20%16V	15002130	
U6	C11R	ELECT C	CE10U0F+20%16V	15002130	
U6	C122	ELECT C	CE100U0F+20%16V	20269020	
U6	C124	ELECT C	CE100U0F+20%16V	20269020	
U6	C12B	ELECT C	CE1U0F+20%50V	20268840	
U6	C12R	ELECT C	CE1U0F+20%50V	20268840	
U6	C130	ELECT C	CE100U0F+20%16V	20269020	
U6	C13B	ELECT C	CE100U0F+20%16V	20269020	
U6	C13G	ELECT C	CE100U0F+20%16V	20269020	
U6	C13R	ELECT C	CE100U0F+20%16V	20269020	
U6	C13S	ELECT C	CE100U0F+20%16V	20269020	
U6	C13Y	ELECT C	CE100U0F+20%16V	20269020	
U6	C14B	ELECT C	CE22U0F+20%16V	20251930	
U6	C14G	ELECT C	CE22U0F+20%16V	20251930	
U6	C14R	ELECT C	CE22U0F+20%16V	20251930	
U6	C14S	ELECT C	CE22U0F+20%16V	20251930	
U6	C14Y	ELECT C	CE22U0F+20%16V	20251930	
U6	C201	ELECT C	CE100U0F+20%10V	20268940	
U6	C203	ELECT C	CE470U0F+20%6.3V	20268620	
U6	C210	ELECT C	CE100U0F+20%10V	20268940	
U6	C21P	ELECT C	CE100U0F+20%10V	20268940	
U6	C222	ELECT C	CE47U0F+20%16V	20267830	
U6	C223	ELECT C	CE47U0F+20%16V	20267830	
U6	C224	ELECT C	CE47U0F+20%16V	20267830	
U6	C311	ELECT C	CE100U0F+20%10V	20268940	
U6	C406	ELECT C	CE100U0F+20%10V	20268940	
U6	C505	ELECT C	CE470U0F+20%6.3V	20268620	
U6	C601	ELECT C	CE47U0F+20%16V	20267830	
U6	C603	ELECT C	CE10U0F+20%50V	20268880	
U6	C606	ELECT C	CE10U0F+20%16V	15002130	
U6	C608	ELECT C	CE100U0F+20%10V	20268940	
U6	C614	ELECT C	CE330U0F+20%6.3V	20269110	
U6	C617	ELECT C	CE100U0F+20%10V	20268940	
U6	C61L	ELECT C	CE47U0F+20%16V	20267830	
U6	C61R	ELECT C	CE47U0F+20%16V	20267830	
U6	C65L	ELECT C	CE47U0F+20%16V	20267830	
U6	C65R	ELECT C	CE47U0F+20%16V	20267830	
U6	C66L	ELECT C	CE47U0F+20%16V	20267830	
U6	C66R	ELECT C	CE47U0F+20%16V	20267830	
U6	D101	CHIP D	1SS355	20496510	
U6	D601	CHIP D	1SS355	20496510	
U6	D602	DIODE	1N4148	70436540	
U6	D604	CHIP D	1SS355	20496510	
U6	IC11	IC	PM0026A	55388940	
U6	IC12	IC	MM1568AJBE	55389040	
U6	IC13	IC	TL431	15069010	
U6	IC14	IC	MC74HC74AD	20997870	
U6	IC15	IC	74HC86	15178670	
U6	IC1P	IC	KIA7805AP	55491690	
U6	IC21	IC	ST15519	55130350	
U6	IC22	IC	M24C02WMM6	20940740	
U6	IC31	IC	HY57V651620BTC-8125M	55156290	
U6	IC41	IC	M29W800AT90N1	55136720	
U6	IC51	IC	M74HCU04M1R	55133310	
U6	IC61	IC	WM8728	55291470	
U6	IC62	IC	BA4560F	55128990	
U6	L101	CHIP COIL	LF-SMD2U2H+10%	55188040	
U6	L102	CHIP COIL	LF-SMD2U2H+10%	55188040	
U6	L202	CHIP COIL	LF-SMD2U2H+10%	55188040	
U6	L203	CHIP BEAD	FCM2012H-102T04	55126670	
U6	L204	CHIP BEAD	FCM2012H-102T04	55126670	
U6	L205	CHIP BEAD	FCM2012H-102T04	55126670	
U6	L210	CHIP BEAD	FCM2012H-102T04	55126670	
U6	L501	CHIP BEAD	FCM2012H-102T04	55126670	
U6	L601	CHIP BEAD	FCM2012H-102T04	55126670	
U6	L602	CHIP BEAD	FCM2012H-102T04	55126670	
U6	L603	CHIP COIL	LF-SMD2U2H+10%	55188040	
U6	L604	CHIP BEAD	FCM2012C-121T06	55126710	
U6	R415	CHIP BEAD	FCM2012H-102T04	55126670	
U6	Q101	CHIP TR	DTA114YKA	55133190	
U6	Q102	CHIP TR	DTC114YKA	55133180	
U6	Q103	CHIP TR	KTC3875Y	20970460	
U6	Q10B	CHIP TR	DTC114YKA	55133180	

U6	Q10G	CHIP TR	DTC114YKA	55133180	
U6	Q10R	CHIP TR	DTC114YKA	55133180	
U6	Q11B	CHIP TR	KTN2222AS	55388740	
U6	Q11G	CHIP TR	KTN2222AS	55388740	
U6	Q11R	CHIP TR	KTN2222AS	55388740	
U6	Q12B	CHIP TR	KTN2222AS	55388740	
U6	Q12G	CHIP TR	KTN2222AS	55388740	
U6	Q12R	CHIP TR	KTN2222AS	55388740	
U6	Q13B	CHIP TR	KTN2907AS	55137830	
U6	Q13G	CHIP TR	KTN2907AS	55137830	
U6	Q13R	CHIP TR	KTN2907AS	55137830	
U6	Q14B	CHIP TR	DTC114YKA	55133180	
U6	Q14G	CHIP TR	DTC114YKA	55133180	
U6	Q14R	CHIP TR	DTC114YKA	55133180	
U6	Q15B	CHIP TR	KTN2907AS	55137830	
U6	Q15G	CHIP TR	KTN2907AS	55137830	
U6	Q15R	CHIP TR	KTN2907AS	55137830	
U6	Q201	CHIP TR	KTC3875Y	20970460	
U6	Q202	CHIP TR	KTC3875Y	20970460	
U6	Q601	CHIP TR	DTA114YKA	55133190	
U6	Q602	CHIP TR	DTC114YKA	55133180	
U6	Q61L	CHIP TR	DTC323TK	55039430	
U6	Q61R	CHIP TR	DTC323TK	55039430	
U6	VR11	TRIM R	PR200R0OHM+30%	55307870	???
U6	X501	CRYSTAL	FILQZ27M0HZ	55128980	

U7 **U7 MAIN PC BOARD**

U7	REF NO.	NAME	DESCRIPTION	PART NO.	NOTES
U7	C119	ELECT C	CE10U0F+20%16V	15002130	
U7	C120	ELECT C	CE10U0F+20%16V	15002130	
U7	C130	ELECT C	CE10U0F+20%16V	15002130	
U7	C139	ELECT C	CE10U0F+20%16V	15002130	
U7	C140	ELECT C	CE10U0F+20%16V	15002130	
U7	C143	ELECT C	CE10U0F+20%16V	15002130	
U7	C149	ELECT C	CE10U0F+20%16V	15002130	
U7	C152	ELECT C	CE330U0F+20%16V	55230030	
U7	C153	ELECT C	CE330U0F+20%16V	55230030	
U7	C154	ELECT C	CE10U0F+20%16V	15002130	
U7	C155	ELECT C	CE10U0F+20%16V	15002130	
U7	C156	ELECT C	CE10U0F+20%16V	15002130	
U7	C157	ELECT C	CE10U0F+20%16V	15002130	
U7	C172	ELECT C	CE10U0F+20%16V	15002130	
U7	C173	ELECT C	CE10U0F+20%16V	15002130	
U7	C174	ELECT C	CE100U0F+20%10V	20268940	
U7	C181	ELECT C	CE10U0F+20%16V	15002130	
U7	C182	ELECT C	CE10U0F+20%16V	15002130	
U7	C185	ELECT C	CE10U0F+20%16V	15002130	
U7	C186	ELECT C	CE10U0F+20%16V	15002130	
U7	C191	ELECT C	CE10U0F+20%16V	15002130	
U7	C192	ELECT C	CE10U0F+20%16V	15002130	
U7	C195	ELECT C	CE10U0F+20%16V	15002130	
U7	C196	ELECT C	CE10U0F+20%16V	15002130	
U7	C201	ELECT C	CE10U0F+20%16V	15002130	
U7	C202	ELECT C	CE10U0F+20%16V	15002130	
U7	C205	ELECT C	CE1U0F+20%50V	20268840	
U7	C206	ELECT C	CE1U0F+20%50V	20268840	
U7	C213	ELECT C	CE22U0F+20%25V	20268890	
U7	C214	ELECT C	CE22U0F+20%25V	20268890	
U7	C215	ELECT C	CE47U0F+20%16V	20267830	
U7	C216	ELECT C	CE47U0F+20%16V	20267830	
U7	C218	ELECT C	CE100U0F+20%25V	20269070	
U7	C219	ELECT C	CE100U0F+20%25V	20269070	
U7	C226	ELECT C	CE47U0F+20%25V	20268910	
U7	C227	ELECT C	CE47U0F+20%25V	20268910	
U7	C229	ELECT C	CE10U0F+20%16V	15002130	
U7	C230	ELECT C	CE10U0F+20%16V	15002130	
U7	C231	ELECT C	CE10U0F+20%16V	15002130	
U7	C232	ELECT C	CE10U0F+20%16V	15002130	
U7	C247	ELECT C	CE10U0F+20%16V	15002130	
U7	C248	ELECT C	CE10U0F+20%16V	15002130	
U7	C260	ELECT C	CE100U0F+20%25V	20269070	
U7	C322	ELECT C	CE10U0F+20%16V	15002130	
U7	C323	ELECT C	CE10U0F+20%16V	15002130	
U7	C351	ELECT C	CE47U0F+20%25V	20268910	
U7	C352	ELECT C	CE47U0F+20%25V	20268910	
U7	C354	ELECT C	CE47U0F+20%25V	20268910	
U7	C355	ELECT C	CE47U0F+20%25V	20268910	
U7	C357	ELECT C	CE47U0F+20%25V	20268910	
U7	C358	ELECT C	CE47U0F+20%25V	20268910	
U7	C405	ELECT C	CE100U0F+20%10V	20268940	
U7	C411	ELECT C	CE47U0F+20%25V	20268910	
U7	C412	ELECT C	CE47U0F+20%25V	20268910	
U7	C413	ELECT C	CE47U0F+20%25V	20268910	
U7	C503	ELECT C	CE47U0F+20%16V	20267830	
U7	C507	ELECT C	CE470U0F+20%6.3V	20268620	

U7	C511	ELECT C	CE47U0F+20%16V	20267830	
U7	C515	ELECT C	CE47U0F+20%6.3V	20268620	
U7	C519	ELECT C	CE47U0F+20%16V	20267830	
U7	C520	ELECT C	CE47U0F+20%6.3V	20268620	
U7	C523	ELECT C	CE47U0F+20%16V	20267830	
U7	C524	ELECT C	CE47U0F+20%6.3V	20268620	
U7	C528	ELECT C	CE47U0F+20%16V	20267830	
U7	C530	ELECT C	CE47U0F+20%16V	20267830	
U7	C532	ELECT C	CE47U0F+20%16V	20267830	
U7	C533	ELECT C	CE47U0F+20%16V	20267830	
U7	C534	ELECT C	CE47U0F+20%16V	20267830	
U7	C535	ELECT C	CE47U0F+20%16V	20267830	
U7	C536	ELECT C	CE47U0F+20%16V	20267830	
U7	C537	ELECT C	CE47U0F+20%16V	20267830	
U7	C538	ELECT C	CE47U0F+20%16V	20267830	
U7	C542	ELECT C	CE47U0F+20%16V	20267830	
U7	C543	ELECT C	CE47U0F+20%16V	20267830	
U7	C544	ELECT C	CE47U0F+20%16V	20267830	
U7	C545	ELECT C	CE47U0F+20%16V	20267830	
U7	C551	ELECT C	CE47U0F+20%16V	20267830	
U7	C552	ELECT C	CE10U0F+20%16V	15002130	
U7	C553	ELECT C	CE10U0F+20%16V	15002130	
U7	C554	ELECT C	CE100U0F+20%16V	20269020	
U7	C555	ELECT C	CE22U0F+20%16V	20251930	
U7	C113	ELECT C	CE10U0F+20%16V	55246790	
U7	C114	ELECT C	CE10U0F+20%16V	55246790	
U7	C123	ELECT C	CE10U0F+20%16V	55246790	
U7	C124	ELECT C	CE10U0F+20%16V	55246790	
U7	C133	ELECT C	CE10U0F+20%16V	55246790	
U7	C134	ELECT C	CE10U0F+20%16V	55246790	
U7	C217	ELECT C	CE100U0F+20%16V	10244270	
U7	C246	ELECT C	CE10U0F+20%16V	55246790	
U7	C251	ELECT C	CE47U0F+20%16V	20342060	
U7	C252	ELECT C	CE47U0F+20%16V	20342060	
U7	C253	ELECT C	CE1U0F+20%50V	20251830	
U7	C254	ELECT C	CE1U0F+20%50V	20251830	
U7	C303	ELECT C	CE47U0F+20%16V	20342060	
U7	C305	ELECT C	CE47U0F+20%16V	20342060	
U7	C310	ELECT C	CE10U0F+20%16V	55246790	
U7	C311	ELECT C	CE10U0F+20%16V	55246790	
U7	C316	ELECT C	CE47U0F+20%16V	20342060	
U7	C319	ELECT C	CE10U0F+20%16V	55246790	
U7	C321	ELECT C	CE47U0F+20%16V	20342060	
U7	C345	ELECT C	CE2U2F+20%50V	20268850	
U7	C347	ELECT C	CE10U0F+20%16V	55246790	
U7	C401	ELECT C	CE1U0F+20%50V	20251830	
U7	C406	ELECT C	CE1U0F+20%50V	20251830	
U7	C417	ELECT C	CE1U0F+20%50V	20251830	
U7	C419	ELECT C	CE10U0F+20%16V	55246790	
U7	C504	FILM C	CPM100N0F+10%63V	55179360	
U7	C508	FILM C	CPM100N0F+10%63V	55179360	
U7	C512	FILM C	CPM100N0F+10%63V	55179360	
U7	C516	FILM C	CPM100N0F+10%63V	55179360	
U7	C556	FILM C	CPF10N0F+10%50V	20266310	
U7	C557	FILM C	CPF10N0F+10%50V	20266310	
U7	D101	ZENER D	1N5235B6.8V	20526990	
U7	D102	ZENER D	1N5235B6.8V	20526990	
U7	D103	ZENER D	MTZJ9.1V	55169720	
U7	D104	ZENER D	MTZJ9.1V	55169720	
U7	D105	DIODE	1N4004	20415060	
U7	D301	C-DIODE	1SS355	20496510	
U7	D302	C-DIODE	1SS355	20496510	
U7	D303	C-DIODE	1SS355	20496510	
U7	D304	C-DIODE	1SS355	20496510	
U7	D305	C-DIODE	1SS355	20496510	
U7	D401	DIODE	RB501V-40	55177870	SCHOTTKY DIODE
U7	D402	ZENER D	UDZS5.1B	55177710	
U7	D403	ZENER D	UDZS5.1B	55177710	
U7	D404	ZENER D	UDZS5.1B	55177710	
U7	D405	C-DIODE	1SS355	20496510	
U7	D406	C-DIODE	1SS355	20496510	
U7	D407	C-DIODE	1SS355	20496510	
U7	L101	DIODE	D-SR1N4004400V1A	20415060	
U7	R435	DIODE	D-SR1N4004400V1A	20415060	
U7	R377	DIODE	D-SR1N4004400V1A	20415060	
U7	IC11	IC	AK4586VQ	55348310	
U7	IC12	IC	74VHC574MX	55170220	
U7	IC13	IC	74VHC574MX	55170220	
U7	IC14	IC	AT27LV010A-90JC	55170270	
U7	IC15	IC	CS493263-CL	55125380	
U7	IC16	IC	74VHCT244AMX	55410610	
U7	IC17	IC	NJM2068M	55142610	
U7	IC18	IC	NJM2068M	55142610	
U7	IC19	IC	NJM2068M	55142610	
U7	IC20	IC	BD3811K1	55348300	

U7	IC21	IC	BU4053BF	20718770	
U7	IC22	IC	NJM2068M	55142610	
U7	IC23	IC	NJM2068M	55142610	
U7	IC24	IC	NJM2068M	55142610	
U7	IC25	IC	NJM2069M	55142610	
U7	IC26	IC	CXP82860-373Q	55506580	
U7	IC27	IC	M24C02WWMN6	20940740	
U7	IC28	IC	KIA7045AF	55471530	
U7	IC29	IC	NJM2072M	55472230	
U7	IC30	IC	NJM4556AM	55164460	
U7	IC31	IC	BU4094BF	20718660	
U7	IC34	IC	BA05FP	55352920	
U7	IC36	IC	BA05FP	55352920	
U7	IC37	IC	NJM2391DL1-33	55471830	
U7	IC38	IC	NJM2391DL1-25	55471630	
U7	IC39	IC	NJM2068M	55142610	
U7	IC51	IC	LA79510E	55348320	
U7	IC52	IC	NJM2584M	55471430	
U7	IC53	IC	NJM78M05DL	55472430	
U7	IC54	IC	NJM79M05DL	55472330	
U7	IC55	IC	NJM2580M	55472550	
U7	NJ11	PIN JACK	RCA2PJW-1502NSPO	55467670	SW PREOUT/COAX IN
U7	NJ12	PHT PARTS	TORX179	55311530	OPT IN
U7	NJ13	PHT PARTS	TOTX179	55311430	OPT OUT
U7	NJ14	PIN JACK	RCA6PJW-4105RSS	55176350	
U7	NJ15	PIN JACK	RCA6PJW-4105RSS	55176350	
U7	NJ16	PIN JACK	MIXSOCKET	55191220	
U7	NJ17	PIN JACK	MIXSOCKET	55191220	
U7	NJ18	PIN JACK	MIXSOCKET	55191220	
U7	NJ19	PIN JACK	MIXSOCKET	55191220	
U7	NJ20	PIN JACK	RCA-314PRBG	55149420	
U7	NJ21	PIN JACK	SCKTRCA-314P	55149420	
U7	R303	BEAD	FCM2012H-102T04	55126670	
U7	R501	BEAD	FCM2012H-102T04	55126670	
U7	R502	BEAD	FCM2012H-102T04	55126670	
U7	R505	BEAD	FCM2012H-102T04	55126670	
U7	R506	BEAD	FCM2012H-102T04	55126670	
U7	R509	BEAD	FCM2012H-102T04	55126670	
U7	R510	BEAD	FCM2012H-102T04	55126670	
U7	R513	BEAD	FCM2012H-102T04	55126670	
U7	R514	BEAD	FCM2012H-102T04	55126670	
U7	R517	BEAD	FCM2012H-102T04	55126670	
U7	R518	BEAD	FCM2012H-102T04	55126670	
U7	R521	BEAD	FCM2012H-102T04	55126670	
U7	R522	BEAD	FCM2012H-102T04	55126670	
U7	R553	BEAD	FCM2012H-102T04	55126670	
U7	R556	BEAD	FCM2012H-102T04	55126670	
U7	R559	BEAD	FCM2012H-102T04	55126670	
U7	R561	BEAD	FCM2012H-102T04	55126670	
U7	R562	BEAD	FCM2012H-102T04	55126670	
U7	R563	BEAD	FCM2012H-102T04	55126670	
U7	Q101	TR	DTA114YKA	55133190	
U7	Q102	TR	KTD1304	55138710	
U7	Q103	TR	KTD1304	55138710	
U7	Q104	TR	KTD1304	55138710	
U7	Q105	TR	KTD1304	55138710	
U7	Q106	TR	KTD1304	55138710	
U7	Q107	TR	KTD1304	55138710	
U7	Q108	TR	DTC114YKA	55133180	
U7	Q109	TR	DTA114YKA	55133190	
U7	Q110	TR	DTA114YKA	55133190	
U7	Q111	TR	DTC114YKA	55133180	
U7	Q112	TR	DTA114YKA	55133190	
U7	Q113	TR	DTC114YKA	55133180	
U7	Q114	TR	DTA114YKA	55133190	
U7	Q115	TR	DTC114YKA	55133180	
U7	Q116	TR	DTA114YKA	55133190	
U7	Q117	TR	DTA114YKA	55133190	
U7	Q118	TR	KTD1304	55138710	
U7	Q119	TR	KTD1304	55138710	
U7	Q120	TR	DTC114YKA	55133180	
U7	Q121	TR	DTA114YKA	55133190	
U7	Q122	TR	KTD1304	55138710	
U7	Q123	TR	KTD1304	55138710	
U7	Q301	TR	KTA1268	55133230	
U7	R582	RESISTOR	22R00HM+5%2W	13001570	
U7	R436	RESISTOR	330R00HM+5%2W	40440590	
U7	X301	CRYSTAL	12M288HZ+/-50PPM	55348350	
U7	X401	CRYSTAL	10M0HZ250HM0F	55126140	
U7	P101	SOCKET AS	15PIN450MM SHIELD	55506780NR	
U7	P105	SOCKET AS	5PIN60MM	55315990NR	
U7	P103	SOCKET AS	12P60MM	55317960NR	
U7	P27	SOCKET AS	2PIN200MM SHIELD	55190850NR	
U8	U8	DIGITAL AMPLIFIER PC BOARD			

	REF NO.	NAME	DESCRIPTION	PART NO.	NOTES
U8					
U8	C505	FILM C	CPM100N0F+5%250V	55470830	
U8	C506	FILM C	CPM100N0F+5%250V	55470830	
U8	C508	FILM C	CPM220N0F+5%100V	55470330	
U8	C509	FILM C	CPM100N0F+5%100V	55470250	
U8	C510	FILM C	CPM100N0F+5%250V	55470830	
U8	C555	FILM C	CPM100N0F+5%250V	55470830	
U8	C556	FILM C	CPM100N0F+5%250V	55470830	
U8	C558	FILM C	CPM220N0F+5%100V	55470330	
U8	C559	FILM C	CPM100N0F+5%100V	55470250	
U8	C560	FILM C	CPM100N0F+5%250V	55470830	
U8	C605	FILM C	CPM100N0F+5%250V	55470830	
U8	C606	FILM C	CPM100N0F+5%250V	55470830	
U8	C608	FILM C	CPM220N0F+5%100V	55470330	
U8	C609	FILM C	CPM100N0F+5%100V	55470250	
U8	C610	FILM C	CPM100N0F+5%250V	55470830	
U8	C655	FILM C	CPM100N0F+5%250V	55470830	
U8	C656	FILM C	CPM100N0F+5%250V	55470830	
U8	C658	FILM C	CPM220N0F+5%100V	55470330	
U8	C659	FILM C	CPM100N0F+5%100V	55470250	
U8	C660	FILM C	CPM100N0F+5%250V	55470830	
U8	C705	FILM C	CPM100N0F+5%250V	55470830	
U8	C706	FILM C	CPM100N0F+5%250V	55470830	
U8	C708	FILM C	CPM220N0F+5%100V	55470330	
U8	C709	FILM C	CPM100N0F+5%100V	55470250	
U8	C710	FILM C	CPM100N0F+5%250V	55470830	
U8	C500	ELECT C	CE2U2F+20%50V	20268850	
U8	C537	ELECT C	CE2U0F+20%16V	20251930	
U8	C550	ELECT C	CE2U2F+20%50V	20268850	
U8	C600	ELECT C	CE2U2F+20%50V	20268850	
U8	C637	ELECT C	CE2U0F+20%16V	20251930	
U8	C650	ELECT C	CE2U2F+20%50V	20268850	
U8	C700	ELECT C	CE2U2F+20%50V	20268850	
U8	C737	ELECT C	CE2U0F+20%16V	20251930	
U8	C517	CERA C	CC220POF+/-10%250V	40434250	
U8	C518	FILM C	CPF1N0F+10%50V	20266120	
U8	C519	FILM C	CPF4N7F+10%50V	20266240	
U8	C567	CERA C	CC220POF+/-10%250V	40434250	
U8	C568	FILM C	CPF1N0F+10%50V	20266120	
U8	C569	FILM C	CPF4N7F+10%50V	20266240	
U8	C617	CERA C	CC220POF+/-10%250V	40434250	
U8	C618	FILM C	CPF1N0F+10%50V	20266120	
U8	C619	FILM C	CPF4N7F+10%50V	20266240	
U8	C620	CERA C	CC1N0F+/-10%50V	80434800	
U8	C621	FILM C	CPF4N7F+10%50V	20266240	
U8	C667	CERA C	CC220POF+/-10%250V	40434250	
U8	C668	FILM C	CPF1N0F+10%50V	20266120	
U8	C669	FILM C	CPF4N7F+10%50V	20266240	
U8	C670	CERA C	CC1N0F+/-10%50V	80434800	
U8	C671	FILM C	CPF4N7F+10%50V	20266240	
U8	C717	CERA C	CC220POF+/-10%250V	40434250	
U8	C718	FILM C	CPF1N0F+10%50V	20266120	
U8	C719	FILM C	CPF4N7F+10%50V	20266240	
U8	C504	ELECT C	CE47U0F+20%35V	55199500	
U8	C534	ELECT C	CE47U0F+20%63V	13076940	
U8	C535	ELECT C	CE47U0F+20%63V	13076940	
U8	C536	ELECT C	CE47U0F+20%35V	55199500	
U8	C554	ELECT C	CE47U0F+20%35V	55199500	
U8	C604	ELECT C	CE47U0F+20%35V	55199500	
U8	C634	ELECT C	CE47U0F+20%63V	13076940	
U8	C635	ELECT C	CE47U0F+20%63V	13076940	
U8	C636	ELECT C	CE47U0F+20%35V	55199500	
U8	C654	ELECT C	CE47U0F+20%35V	55199500	
U8	C704	ELECT C	CE47U0F+20%35V	55199500	
U8	C734	ELECT C	CE47U0F+20%63V	13076940	
U8	C735	ELECT C	CE47U0F+20%63V	13076940	
U8	C736	ELECT C	CE47U0F+20%35V	55199500	
U8	C516	ELECT C	CE33U0F+20%200V	55471330	
U8	C566	ELECT C	CE33U0F+20%200V	55471330	
U8	C616	ELECT C	CE33U0F+20%200V	55471330	
U8	C666	ELECT C	CE33U0F+20%200V	55471330	
U8	C716	ELECT C	CE33U0F+20%200V	55471330	
U8	D502	DIODE	MURS120T3	15767310	
U8	D503	DIODE	MURS120T3	15767310	
U8	D504	DIODE	MUR120	25474830	
U8	D505	DIODE	MUR120	25474830	
U8	D506	DIODE	MURS120T3	15767310	
U8	D507	ZENER D	UDZS3.3B	55394360	
U8	D508	ZENER D	UDZS3.3B	55394360	
U8	D511	DIODE	MURS120T3	55578040	
U8	D512	DIODE	MURS120T3	55578040	
U8	D552	DIODE	MURS120T3	15767310	
U8	D553	DIODE	MURS120T3	15767310	
U8	D554	DIODE	MUR120	25474830	
U8	D555	DIODE	MUR120	25474830	

U8	D556	DIODE	MURS120T3	15767310	
U8	D557	ZENER D	UDZS3.3B	55394360	
U8	D558	ZENER D	UDZS3.3B	55394360	
U8	D561	DIODE	MURS120T3	15767310	
U8	D562	DIODE	MURS120T3	15767310	
U8	D602	DIODE	MURS120T3	15767310	
U8	D603	DIODE	MURS120T3	15767310	
U8	D604	DIODE	MUR120	25474830	
U8	D605	DIODE	MUR120	25474830	
U8	D606	DIODE	MURS120T3	15767310	
U8	D607	ZENER D	UDZS3.3B	55394360	
U8	D608	ZENER D	UDZS3.3B	55394360	
U8	D611	DIODE	MURS120T3	15767310	
U8	D612	DIODE	MURS120T3	15767310	
U8	D613	DIODE	1SS355	20496510	
U8	D614	DIODE	1SS355	20496510	
U8	D652	DIODE	MURS120T3	15767310	
U8	D653	DIODE	MURS120T3	15767310	
U8	D654	DIODE	MUR120	25474830	
U8	D655	DIODE	MUR120	25474830	
U8	D656	DIODE	MURS120T3	15767310	
U8	D657	ZENER D	UDZS3.3B	55394360	
U8	D658	ZENER D	UDZS3.3B	55394360	
U8	D661	DIODE	MURS120T3	15767310	
U8	D662	DIODE	MURS120T3	15767310	
U8	D702	DIODE	MURS120T3	15767310	
U8	D703	DIODE	MURS120T3	15767310	
U8	D704	DIODE	MUR120	25474830	
U8	D705	DIODE	MUR120	25474830	
U8	D706	DIODE	MURS120T3	15767310	
U8	D707	ZENER D	UDZS3.3B	55394360	
U8	D708	ZENER D	UDZS3.3B	55394360	
U8	D711	DIODE	MURS120T3	15767310	
U8	D712	DIODE	MURS120T3	15767310	
U8	D713	DIODE	1SS355	20496510	
U8	D752	DIODE	MURS120T3	15767310	
U8	D753	DIODE	MURS120T3	15767310	
U8	D756	DIODE	MURS120T3	15767310	
U8	SP51	TRM	JW-5508AD	55467650	FRONT SPEAKERS
U8	SP52	TRM	JW-5506AD	55467660	CENTER/SR SPEAKERS
U8	B501	BEAD	FILLCEMI100N0	55146640	
U8	B601	BEAD	FILLCEMI100N0	55146640	
U8	B701	BEAD	FILLCEMI100N0	55146640	
U8	L500	COIL	LF16U0H+10%	55472130	
U8	L550	COIL	LF16U0H+10%	55472130	
U8	L600	COIL	LF16U0H+10%	55472130	
U8	L650	COIL	LF16U0H+10%	55472130	
U8	L700	COIL	LF16U0H+10%	55472130	
U8	IC50	IC	TA3020	55470230	
U8	IC60	IC	TA3020	55470230	
U8	IC70	IC	TA3020	55470230	
U8	Q500	FET	STW34NB20	55471230	
U8	Q501	FET	STW34NB20	55471230	
U8	Q502	TR	DTC114YKA	55133180	
U8	Q503	TR	DTC114YKA	55133180	
U8	Q550	FET	STW34NB20	55471230	
U8	Q551	FET	STW34NB20	55471230	
U8	Q552	TR	DTA114YKA	55133190	
U8	Q553	TR	DTC114YKA	55133180	
U8	Q554	TR	DTC114YKA	55133180	
U8	Q600	FET	STW34NB20	55471230	
U8	Q601	FET	STW34NB20	55471230	
U8	Q602	TR	DTC114YKA	55133180	
U8	Q603	TR	DTC114YKA	55133180	
U8	Q604	TR	DTC114YKA	55133180	
U8	Q650	FET	STW34NB20	55471230	
U8	Q651	FET	STW34NB20	55471230	
U8	Q700	FET	STW34NB20	55471230	
U8	Q701	FET	STW34NB20	55471230	
U8	Q702	TR	DTC114YKA	55133180	
U8	Q703	TR	DTC114YKA	55133180	
U8	R504	TRIM R	PR10K0OHM+30%	20661430	DCOFFSET FL
U8	R513	RESISTOR	14R0OHM+5%1W	55469680	
U8	R514	RESISTOR	14R0OHM+5%1W	55469680	
U8	R515	RESISTOR	RW10MI0OHM+5%2W	55469730	
U8	R516	RESISTOR	10MI0OHM+5%2W	55469730	
U8	R517	RESISTOR	20R0OHM+5%5W	55470030	
U8	R523	RESISTOR	2R2OHM+5%1W	55469830	
U8	R524	RESISTOR	2R2OHM+5%1W	55469830	
U8	R525	RESISTOR	16R0OHM+5%2W	55469930	
U8	R554	TRIM R	PR10K0OHM+30%	20661430	DCOFFSET FR
U8	R563	RESISTOR	14R0OHM+5%1W	55469680	
U8	R564	RESISTOR	14R0OHM+5%1W	55469680	
U8	R565	RESISTOR	10MI0OHM+5%2W	55469730	
U8	R566	RESISTOR	10MI0OHM+5%2W	55469730	

U8	R567	RESISTOR	20R0OHM+5%5W	55470030	
U8	R573	RESISTOR	2R2OHM+5%1W	55469830	
U8	R574	RESISTOR	2R2OHM+5%1W	55469830	
U8	R575	RESISTOR	16R0OHM+5%2W	55469930	
U8	R604	TRIM R	PR10K0OHM+30%	20661430	DCOFFSET CT
U8	R613	RESISTOR	14R0OHM+5%1W	55469680	
U8	R614	RESISTOR	14R0OHM+5%1W	55469680	
U8	R615	RESISTOR	10MI0OHM+5%2W	55469730	
U8	R616	RESISTOR	10MI0OHM+5%2W	55469730	
U8	R617	RESISTOR	20R0OHM+5%5W	55470030	
U8	R623	RESISTOR	2R2OHM+5%1W	55469830	
U8	R624	RESISTOR	2R2OHM+5%1W	55469830	
U8	R625	RESISTOR	RW16R0OHM+5%2W	55469930	
U8	R654	TRIM R	PR10K0OHM+30%	20661430	DCOFFSET SR
U8	R663	RESISTOR	14R0OHM+5%1W	55469680	
U8	R664	RESISTOR	14R0OHM+5%1W	55469680	
U8	R665	RESISTOR	10MI0OHM+5%2W	55469730	
U8	R666	RESISTOR	10MI0OHM+5%2W	55469730	
U8	R667	RESISTOR	20R0OHM+5%5W	55470030	
U8	R673	RESISTOR	2R2OHM+5%1W	55469830	
U8	R674	RESISTOR	2R2OHM+5%1W	55469830	
U8	R675	RESISTOR	RW16R0OHM+5%2W	55469930	
U8	R704	TRIM R	PR10K0OHM+30%	20661430	DCOFFSET SL
U8	R713	RESISTOR	14R0OHM+5%1W	55469680	
U8	R714	RESISTOR	14R0OHM+5%1W	55469680	
U8	R715	RESISTOR	10MI0OHM+5%2W	55469730	
U8	R716	RESISTOR	10MI0OHM+5%2W	55469730	
U8	R717	RESISTOR	20R0OHM+5%5W	55470030	
U8	R723	RESISTOR	2R2OHM+5%1W	55469830	
U8	R724	RESISTOR	2R2OHM+5%1W	55469830	
U8	R725	RESISTOR	RW16R0OHM+5%2W	55469930	
U8	RY50	RELAY	12V270OHM5A	55471130	SP-A FL/FR
U8	RY60	RELAY	12V270OHM5A	55471130	LS/RS
U8	RY61	RELAY	12V270OHM5A	55471130	SP-B FL/FR
U8	RY70	RELAY	12V270OHM5A	55471130	CENTER
U8	P906	SOCKET AS	6PIN300MM	55507290NR	
U8	P907	SOCKET AS	5PIN300MM	55507080NR	
U8	P905	SOCKET AS	3PIN210MM	55432960NR	

PACKING VIEW PARTS LIST

DR-C500

REF NO.	PART NEME	DESCRIPTION	PART NO.	REMARK
050	CATON BOX		55467120	
060	PAD	RIGHT	55467220	
070	PAD	LEFT	55467320	
080	REMOTE CONTROLLER	RC-508M	55467420	
090	BATTERY	R03 AAA	3010124	T
100	INSTRUCTION MANUAL	E	55463220	
110	SHEET	920mm x 1000mm	55170660	
120	AM ANTENNA	ANTENNA LOOP AM S0146BL-101 0 0	55208620	
130	WARRANTY CARD		29365090A	ML
150	FM ANTENNA	FIA-101-FM 0 0	55127470	
160	POLY BAG	260mm x 410mm	55170650	
170	POLY BAG	70mm x 250mm	20715540	
210	TAPE	3M #373 0.06MM 76MM TRA	20357620	
220	TAPE	3M#610 0.11MM 12.7MM --	20194840	
260	LABEL	HOOKUP ONKYO	55513580	
270	LABEL	SPEAKER	29363059A	ML
310	POS LABEL	DR-C500	55468430	
320	AUDIO CABLE	1500mm BK 0 A0	55176530	
330	POLY BAG	45mm x 80mm	55030950	

PACKING VIEW PARTS LIST

LS-V500C

REF NO.	PART NEME	DESCRIPTION	PART NO.	REMARK
060	PAD	RIGHT	55467220	
070	PAD	LEFT	55467320	
080	REMOTE CONTOLLER	RC-508M	55467420	
090	BATTERY	R03 AAA	3010124	
100	INSTRUCTION MANUAL	E	55463220	
110	SHEET	920mm x 1000mm	55170660	
120	AM ANTENNA	ANTENNA LOOP AM S0146BL-101 0 0	55208620	
130	WARRANTY CARD		29365090A	ML
150	FM ANTENNA	FIA-101-FM 0 0	55127470	
160	POLY BAG	260mm x 410mm	55170650	
170	POLY BAG	70mm x 250mm	20715540	
210	TAPE	3M #373 0.06MM 76MM TRA	20357620	
220	TAPE	3M#610 0.11MM 12.7MM --	20194840	
230	CARTON BOX	LS-V500C (HTP-102S)	55477940	
240	CARTON BOX	(OUTER) LS-V500C	55477930	
270	LABEL	SPEAKER	29363059A	ML
280	PAD	BOTTOM LS-V500C	55553810	
290	PAD	TOP LS-V500C	55553710	
300	INSTRUCTION SHEET	AC PRI LEAFLET QUICK SETUP SHEET	55558370	
310	POS LABEL	LS-V500C	55573140	
320	AUDIO CABLE	1500mm BK 0 A0	55176530	
330	CARTON BOX	AC CARTON INNER LS-V500C	55603260	