

ONKYO SERVICE MANUAL

DVD RECEIVER MODEL DR-L50

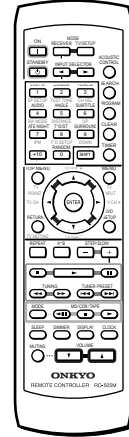
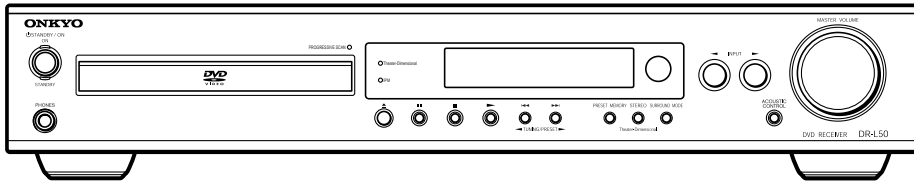

RC-505M

Titanium color models

UDS4P, UDT3P	120V AC, 60Hz
UGT3P, UGR6P	220-230V AC, 50/60Hz
UPP2P, UPA4P	230-240V AC, 50Hz

SAFETY-RELATED COMPONENT WARNING!!

COMPONENTS IDENTIFIED BY MARK  ON THE SCHEMATIC DIAGRAM AND IN THE PARTS LIST ARE CRITICAL FOR RISK OF FIRE AND ELECTRIC SHOCK. REPLACE THESE COMPONENTS WITH ONKYO PARTS WHOSE PART NUMBERS APPEAR AS SHOWN IN THIS MANUAL.

MAKE LEAKAGE-CURRENT OR RESISTANCE MEASUREMENTS TO DETERMINE THAT EXPOSED PARTS ARE ACCEPTABLY INSULATED FROM THE SUPPLY CIRCUIT BEFORE RETURNING THE APPLIANCE TO THE CUSTOMER.

SPECIFICATIONS

AMPLIFIER SECTION

Power Output (FTC)	All channels 25 watts per channel min. RMS. into 6 ohms two channel driven, 1,000 Hz with no more than 10% total harmonic distortion.	Damping Factor	40 at 8 ohms
Continuous power output (DIN)	All channels 21 watts per channel min. RMS. into 6 ohms two channel driven, 1,000 Hz	Input Sensitivity and Impedance	DIGITAL OPTICAL IN -21 to -15 dBm LINE (TV/LINE, MD/CDR/TAPE) 200 mV/50 kohms
Continuous Power output (EIAJ)	All channel 26 watts per channel min. RMS. into 6 ohms two channel driven, 1,000 Hz	Output Level and Impedance	DIGITAL OPTICAL OUT -21 to -15 dBm REC OUT (MD/CDR/TAPE) 200 mV, 2.2 kohms PRE OUT(SUBWOOFER) 1 V, 470 ohms
Total Harmonic Distortion	10 % at rated power 0.2 % at 1 watt output	Frequency Response	20 to 30,000 Hz : +/- 0.8 dB
IM Distortion	10 % at rated power 0.2 % at 1 watt output	Acoustic Control	1: +9 dB at 82 Hz 2: +9 dB at 82 Hz +6 dB at 10,000 Hz
		Signal-to-noise Ratio	100 dB (0.5 V INPUT LINE)
		Muting	-50 dB

DVD SECTION

Signal readout system	Optical non-contact	Laser	Semiconductor laser, wavelength 650 nm
Linear velocity	3.49 m/s (Single Layer) 3.84 m/s (Dual Layer)	Frequency response	10 Hz to 44 kHz (96 kHz)
Error correction system	Reed Solomon Product Code	Signal-to-noise ratio (digital audio)	More than 100 dB
Signal system	PAL/Auto Mode	Audio dynamic range (digital audio)	More than 93 dB
Regional restriction code	European area: 2 South-east Asian area: 3 Australian and South American area: 4 PRC: 6	Harmonic distortion (digital audio)	Less than 0.025%
Output Level and Impedance		Wow and flutter	Below threshold of measurability
Composite	1.0Vp-p, 75 ohms	Operating conditions	Temperature: 5°C to 35°C (41°F to 95°F), Operation status: Horizontal
S-Video	Y:1.0 Vp-p, 75 ohms C: 0.286 Vp-p, 75 ohms		
Component (Except European models)	Y:1.0 Vp-p, 75 ohms Pb, Pr: 0.7 Vp-p, 75 ohms		
RGB(European models)	0.7 Vp-p, 75 ohms		

TUNER SECTION

Tuning Range	FM: 87.50 to 108.00 MHz (50 kHz steps) AM: (South American models) 530 to 1710 kHz (10 kHz steps)	(Other models) 522 to 1611 kHz (9 kHz steps)
Usable Sensitivity	FM: Mono 11.2 dBf, 1.0 µV (75 ohms IHF) 0.9 µV (75 ohms DIN) Stereo 17.2 dBf, 2.0 µV (75 ohms IHF) 23 µV (75 ohms DIN)	
50 dB Quieting Sensitivity	AM: 30 µV FM: Mono 17.2 dBf, 2.0 µV (75 ohms) Stereo 37.2 dBf, 20.0 µV (75 ohms)	
Capture Ratio	FM: 2.0 dB	
Image Rejection Ratio	FM: 40 dB (South American models) AM: 40 dB	85 dB (Other models)
IF Rejection Ratio	FM: 90 dB AM: 40 dB	
Signal-to-noise Ratio	FM: Mono 73 dB, IHF Stereo 67 dB, IHF AM: 40 dB	
Alternate Channel Att. (+/- 400 kHz) Selectivity	FM: Mono 55 dB, IHF FM: 50 dB, DIN 55dB, IHF	
AM Suppression Ratio	FM: 50 dB	
	Harmonic Distortion	FM: Mono 0.2 % Stereo 0.3 % AM: 0.7 %
	Frequency response	FM: 30 to 15,000 Hz (+/- 1.0 dB)
	Stereo Separation	FM: 45 dB at 1,000 Hz 30 dB at 100 to 10,000 Hz
	Stereo Threshold	FM: 17.2 dBf, 20 µV (75 ohms)
	Output	FM: 750 mV AM: 150 mV

GENERAL

Power Supply	AC 120 volts, 60 Hz	Power Supply	AC 220-230 volts, 50/60 Hz
Power Consumption	: 130 W	Power Consumption	: 120 W
Power Consumption (standby mode)	: 2.0 W	Power Consumption (standby mode)	: 2.6 W
	29 W (*)		29 W (*)
Power Supply	AC 230-240 volts, 50 Hz	Dimensions (W x H x D)	435×81×366 mm (17 ¹ / ₈ ×3 ³ / ₁₆ ×14 ⁷ / ₁₆ ins.)
Power Consumption	: 120 W	Weight	7.0 kg (15.4 lb.)
Power Consumption (standby mode)	: 2.6 W		
	29 W (*)		

(*) When clock display is on.

Specifications and features are subject to change without notice.

EXPLODED VIEW

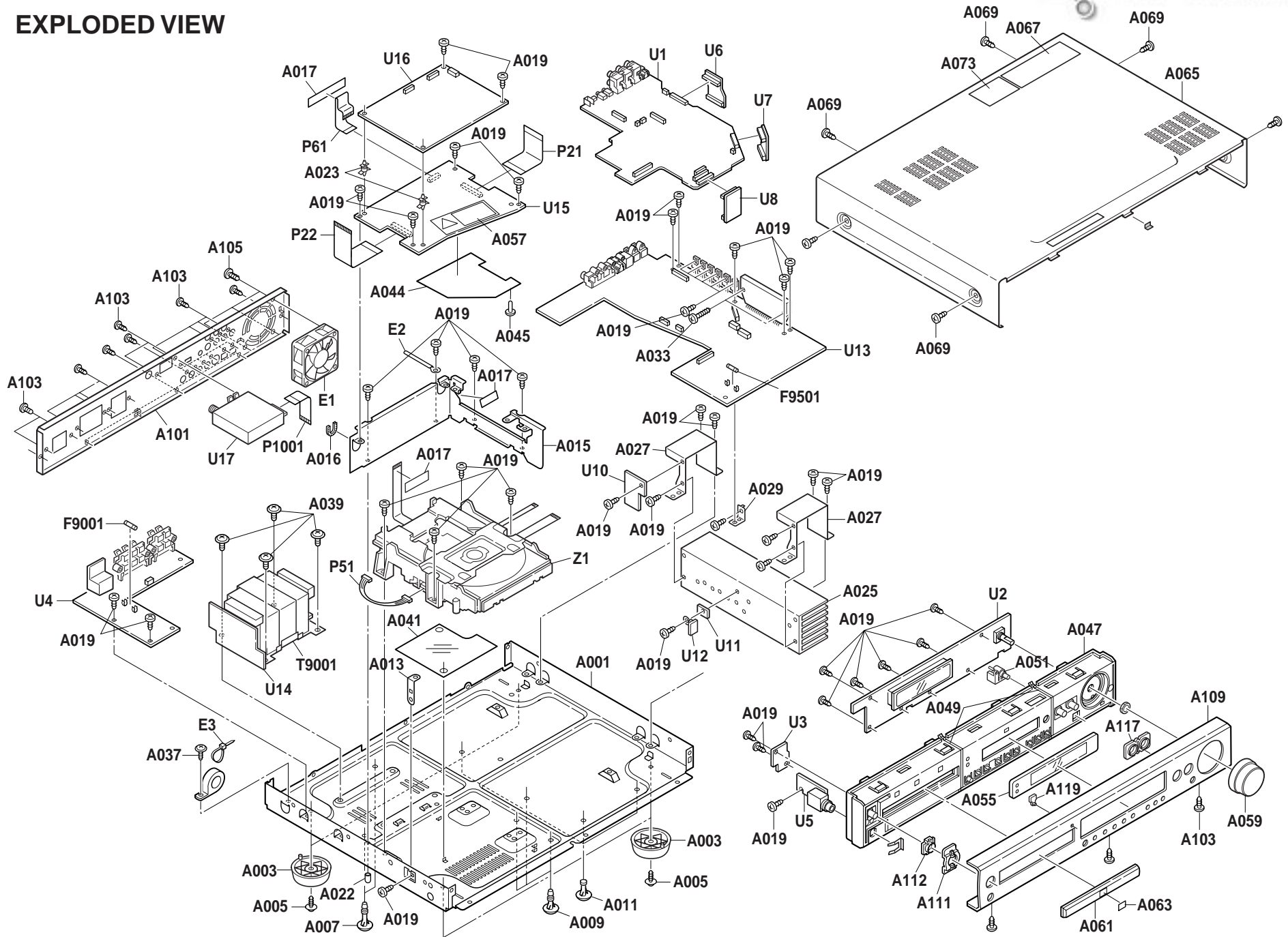

EXPLODED VIEWS OF MECHANISM-1

DVD MECHANISM:DB-VLD304

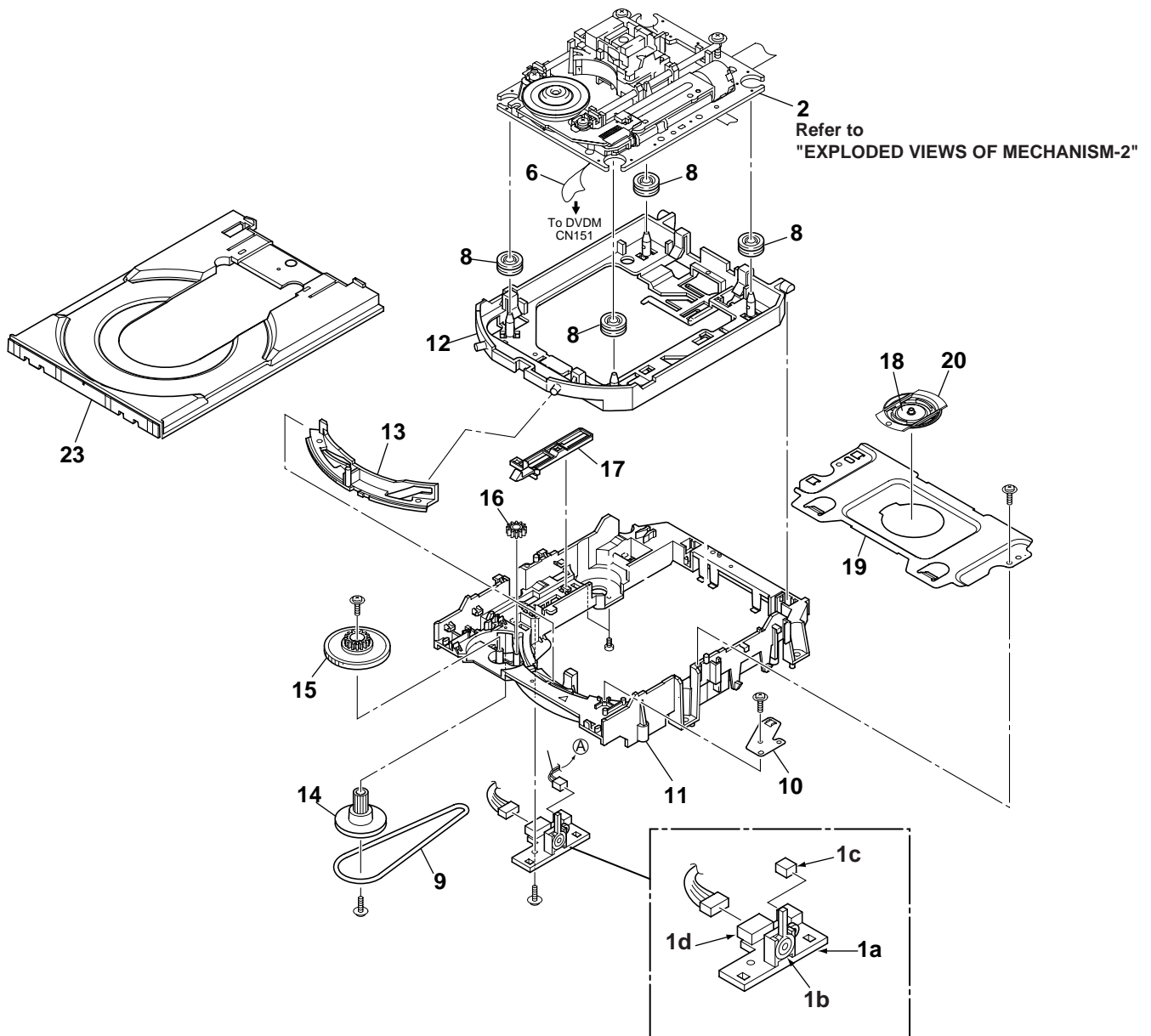

PARTS LIST

No.	Description	Part No.	No.	Description	Part No.
1a	Loading switch PC board	VNP1836	12	Float Base DVD	VNL1918
1b	Switch	VSK1011	13	Drive Cam	VNL1919
1c	Connector KR(2P)	S2B-PH-K	14	Gear Pulley	VNL1921
1d	Connector KR(5P)	S5B-PH-K	15	Loading Gear	VNL1922
2	Traverse mechanism assy	VXX2782	16	Drive Gear	VNL1923
6	Flexible Cable (26P)	VDA1864	17	SW Lever	VNL1925
8	Floating Rubber	VEB1327	18	Clamper Plate	VNE2251
9	Belt	VEB1328	19	Bridge	VNE2252
10	Stabilizer	VNE2253	20	Clamper	VNL1924
11	Loading Base	VNL1917	23	Tray ABS	VNL1920

EXPLODED VIEWS OF MECHANISM-2

DVD MECHANISM:DB-VLD304 (TRAVERSE UNIT)

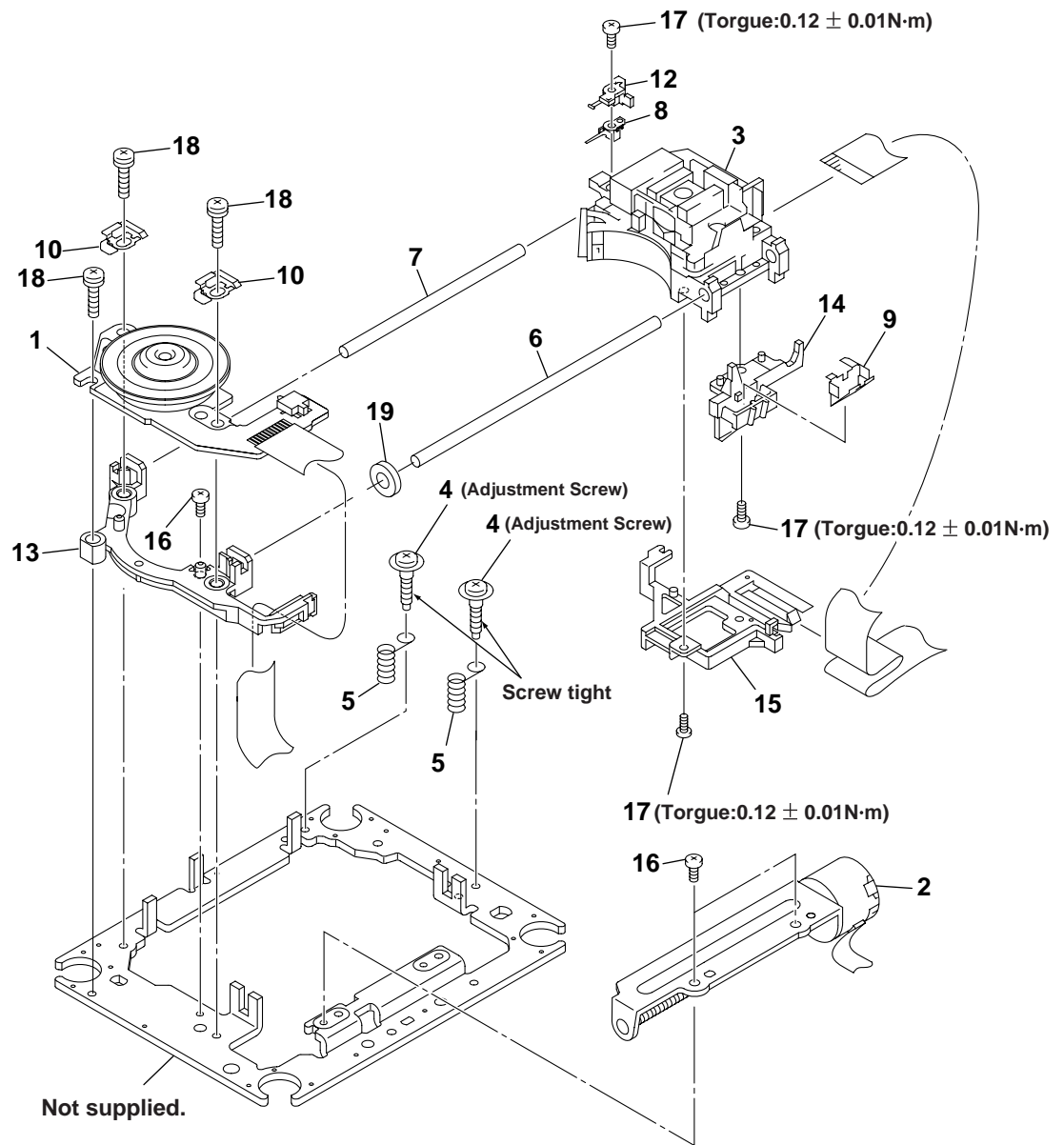

PARTS LIST

No.	Description	Part No.	No.	Description	Part No.
1	Spindle Motor	VXM1088	9	Joint Spring	VNC1019
2	Stepping Motor	VXM1090	10	Support Spring	VNC1020
3	Pickup Assy-S	OXX8003	11	Mechanism Chassis	---
4	Skew Screw	VBA1080	12	Slider	VNL1811
5	Skew Spring	VBH1335	13	Spacer	VNL1913
6	Guide Bar	VLL1514	14	Joint	VNL1914
7	Sub Guide Bar	VLL1515	15	FFC Holder	VNL1915
8	Hold Spring	VNC1017	16	Screw	BBZ20P050FZK
			17	Screw	OBA8009
			18	Screw	PMA26P100FMC
			19	Damper Sheet	VEB1335

BLOCK DIAGRAM

1
2
3
4
5

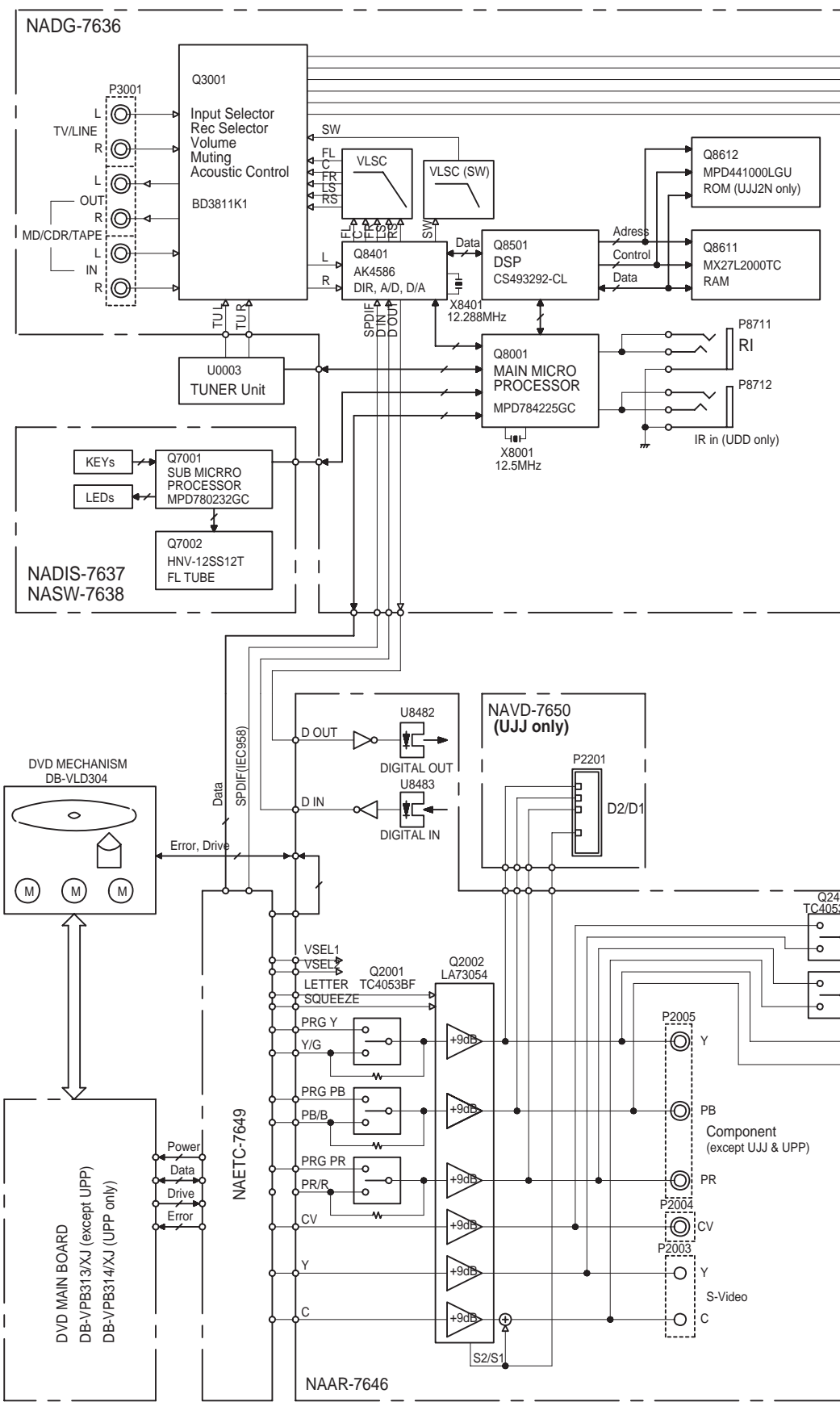

E

F

G

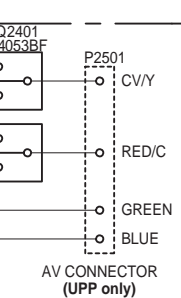
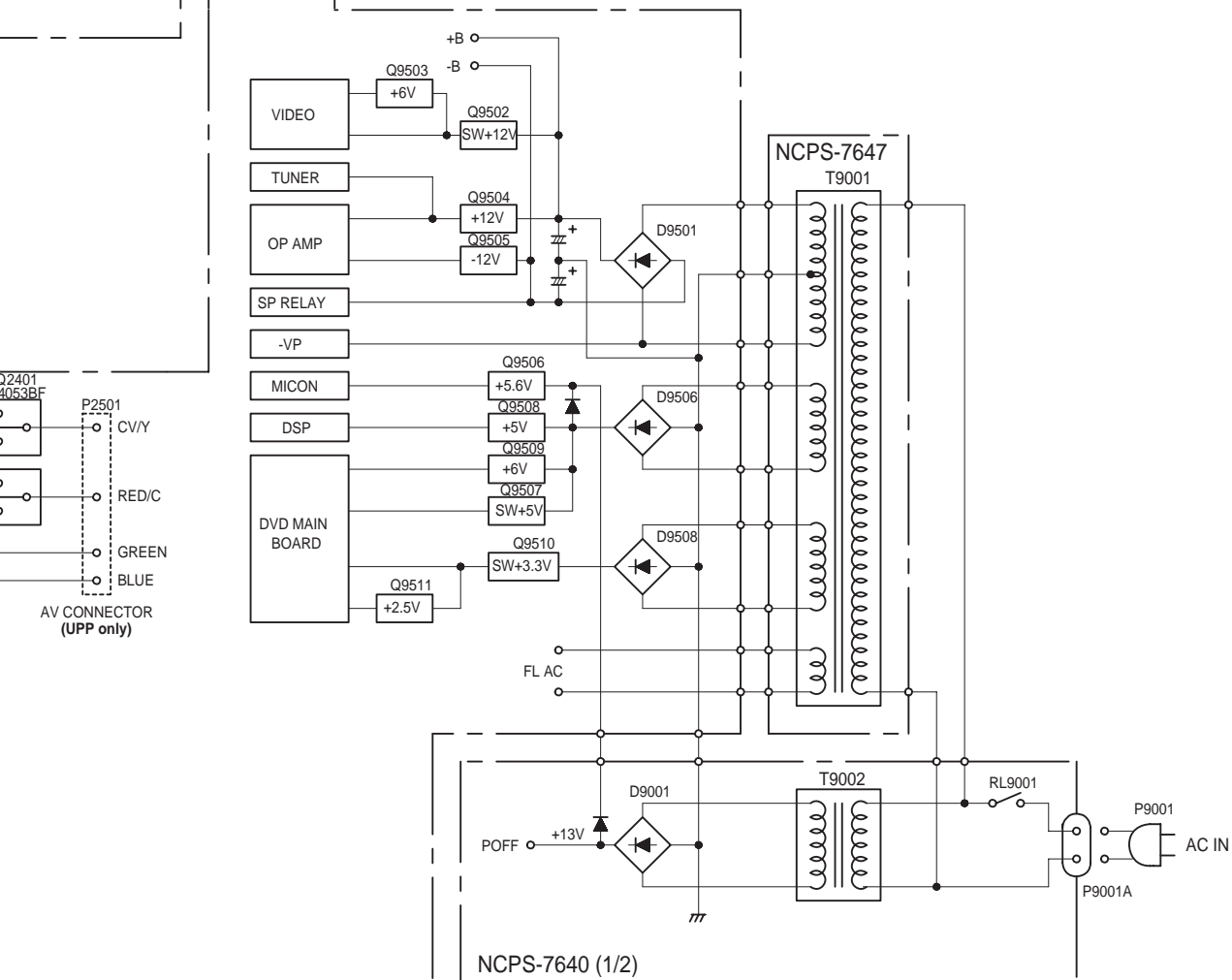
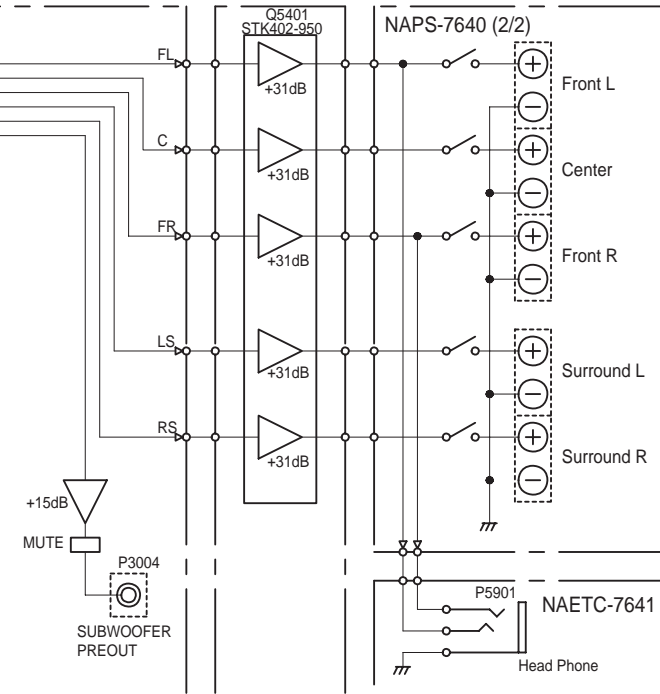

EXPLODED VIEW PARTS LIST

DR-L50

[NOTES]

UDT3P: Some Asian area (AC 230V, Regional code-3)

UDS4P: South America area (Regional code-4)

UPP2P: European area (Regional code-2)

UPA4P: Australian area (Regional code-4)

UGR6P: Chinese area (Regional code-6)

UGT3P: Korean area (Regional code-3)

REF NO.	NAME	DESCRIPTION	PART NO.
A001	CHASSIS		27100426
A003	BOTTOM LEG	(AS)	27175392
A005	SCREW	3TTW+8B(BC)	831430088
A007	HOLDER	KGLS-18RF	27190657
A009	HOLDER	KGLS-10RF	27190428A
A011	HOLDER	KGPS-10RF	27190813
A013	RETAINER	(MB)	27141821
A015	BRACKET	(SHLD)	27130888A
A016	BUSHING	KG-016L	28170031
A017	TAPE	TAPE(CROSS-16U)	29110083
A019	SCREW	3TTB+8B	838130088
A022	CAP	(SCREW)	28330135A
A023	HOLDER	MSPLS-3	27191177
A025	HEAT SINK	175 RG-418378	27160515
A027	BRACKET	(H)	27130889
A029	BRACKET	BRACKET	27130745
A033	SCREW	3TTB+16S(BC)	838430167
A037	SCREW	3TTW+8B(BC)	831430088
A039	SCREW	4TTC+6C(BC)	830440069
A041	ISO PLT	(B)	28175288
A044	ISO PLT	(T)	28175292
A045	RIVET	P-RIVET NRP-345	880009
A047	F BRACKET	AS	27111297
A049	TAPE	.	29110161
A051	KNOB	(ACC)AS	28325947A
A055	CLEAR PLT	.	28191973
A057	LABEL(DVD2)	..	29362648
A059	KNOB	(VOL)AS	28326033
A061	DOOR	.	28148484A
A063	PLATE	(DVD)	27262651
A065	COVER	.	28184848
A067	LABEL	(PATENT)	29362760A
A069	SCREW	3TTB+8B(UN)	838930088
A073	LABEL	(COVER)	29362772
A101	REAR PANEL	UPP2P	27123021
A101	REAR PANEL	UPA4P	27123026
A101	REAR PANEL	UGR6P	27123024
A101	REAR PANEL	UDT3P	27123022
A101	REAR PANEL	UGT3P	27123025
A101	REAR PANEL	UDS4P	27123023
A103	SCREW	3TTB+8B(BC)	838430088
A105	SCREW	5STP+10BQ(BC)	833450102
A109	F PANEL	.	27212437
A109	F PANEL	.	27212449
A111	FACET	(STBY)	28198930
A112	GUIDE	(STBY)	27268048
A119	FACET	(REC)	28198840
A117	GUIDE	(INPUT)	27268062
E1	FAN	D06T-24TH	24502313
E2	CLIP	CS-1U	27255004
E3	WIRE TIE	BINDER(CLAMPER)UL	260208
F9001	FUSE	1.25A-SE-EAWK FUSE	252071
F9001	FUSE	2.5A-UL/T-237	252160
F9501	FUSE	4A-SE-EAK FUSE	252077
P1001	FFC	NCFC7-150512	2047150512
P21	FFC	NCFC4-30029	204430029
P22	FFC	NCFC4-30029	204430029
P51	SOCKET AS	NSAS-10P0997	20022391010
P61	FFC	NCFC4-171012	2044171012
T9001	P TRANS	NPT-1455P	2301658
T9001	P TRANS	NPT-1455G	2301659
T9001	P TRANS	NPT-1455D	2301657
U17	TUNER UNIT	TFCE1E512A	240135
U17	TUNER UNIT	TFCE1E512A	240135

U17	TUNER UNIT	TFCE1E512A	240135
U17	TUNER UNIT	TFCE1E512A	240135
U17	TUNER UNIT	TFCE1E512A	240135
U17	TUNER UNIT	TFCE1U114B	240134A
U16	PWB AS	DB-VPB314/XJ	24150034
U16	PWB AS	DB-VPB313/XJ	24150033
Z1	DVD M	DB-VLD304	24801015
U1	DSP AND MICROPROCESSOR PC board	NADG-7636-1	1A952536-1B
	DSP AND MICROPROCESSOR PC board	NADG-7636-1	1A952536-1C
	DSP AND MICROPROCESSOR PC board	NADG-7636-1	1A952536-1D
	DSP AND MICROPROCESSOR PC board	NADG-7636-1	1A952536-1E
	DSP AND MICROPROCESSOR PC board	NADG-7636-1	1A952536-1F
U2	DISPLAY PC board	NADIS-7637	1A952537-1B
	DISPLAY PC board	NADIS-7637	1A952537-1C
	DISPLAY PC board	NADIS-7637	1A952537-1D
	DISPLAY PC board	NADIS-7637	1A952537-1E
	DISPLAY PC board	NADIS-7637	1A952537-1F
U3	STANDBY SWITCH PC board	NASW-7638	1A952538-1B
	STANDBY SWITCH PC board	NASW-7638	1A952538-1C
	STANDBY SWITCH PC board	NASW-7638	1A952538-1D
	STANDBY SWITCH PC board	NASW-7638	1A952538-1E
	STANDBY SWITCH PC board	NASW-7638	1A952538-1F
U4	POWER SUPPLY PC board	NAPS-7640	1A952540-1B
	POWER SUPPLY PC board	NAPS-7640	1A952540-1C
	POWER SUPPLY PC board	NAPS-7640	1A952540-1D
	POWER SUPPLY PC board	NAPS-7640	1A952540-1E
	POWER SUPPLY PC board	NAPS-7640	1A952540-1F
U5	PHONES JACK PC board	NAETC-7641	1A952541-1B
	PHONES JACK PC board	NAETC-7641	1A952541-1C
	PHONES JACK PC board	NAETC-7641	1A952541-1D
	PHONES JACK PC board	NAETC-7641	1A952541-1E
	PHONES JACK PC board	NAETC-7641	1A952541-1F
U6	CONNECTOR PC board	NAETC-7642	1A952542-1B
U7	CONNECTOR PC board	NAETC-7643	1A952543-1B
U8	CONNECTOR PC board	NAETC-7644	1A952544-1B
U10	ISOLATION PC board	NAETC-7760	1A952560-1B
U11	HOLDER PC board	NAETC-7639	1A952539-1B
U12	THERMISTOR PC board	NAETC-7645	1A952545-1B
U13	MAIN PC board	NAAR-7646	1A952546-1B
	MAIN PC board	NAAR-7646	1A952546-1C
U14	TRANSFORMER TERMINAL PC board	NAPS-7647	1A952547-1B
	TRANSFORMER TERMINAL PC board	NAPS-7647	1A952547-1C
U15	DVD CONNECTOR PC board	NAETC-7649	1A952549-1B
	DVD CONNECTOR PC board	NAETC-7649	1A952549-1C

PACKING PARTS LIST

REF NO.	NAME	DESCRIPTION	PART NO.
A401	PAD	.	29092068
A405	SHEET	.	29095847
A407	TAPE	(SEROHAN)NITTO NO.29	29110149
A409	PP TAPE	W48 OPP TAPE	29110148
A411	POLY BAG	350*250	29100097-1A
A417	LABEL	(SP CABLE)	29363059A
A419	SHEET	(CORNER)	29095935
A501	CARTON	UPP	29053955
A501	CARTON	UGR	29053956
A5031	EAN LABEL	.	29363228
A505	LABEL	UPA4P	29363233
A505	LABEL	UDT3P	29363230
A505	LABEL	UGT3P	29363232
A505	LABEL	UDS4P	29363231
A511	LABEL	(PE-LD)	29361573
A901	BATTERY	UM-3	3010054
A902	ANT COIL	NMA-3057	232140
A910	RGB CORD	YAF11-0697	2010368
A911	CORD AS	(S CORD) or	2010380 or
	CORD AS	TPX3000	2010360
A912	PIN CORD AS	RCA-3P(YWR) or	2010359 or
	PIN CORD AS	RCA-3P(YWR)	2010359TAIDA
A913	FM-ANT-AS	P	292116
A913	FM ANT AS	Type D	292160
A914	FM ADPTER	YAE21-0237	25065462
A921	REMO CON	RC-505M	24140505
A931	INS MANUAL	E(DR-L50)	29343399

A932	INS MANUAL	F(DR-L50)	29343400
A933	INS MANUAL	G(DR-L50)	29343401
A938	INS MANUAL	Cs(DR-L50)	29343407
A939	INS MANUAL	Cs(DR-L50)	29343406
A934	INS MANUAL	I(DR-L50)	29343402
A935	INS MANUAL	S(DR-L50)	29343403
A936	INS MANUAL	D(DR-L50)	29343404
A937	INS MANUAL	Sw(DR-L50)	29343405
A940	INST SHEET	.	29355410
P9001	AC CORD	AS-CEE	253299HIT
P9001	AC CORD	AS-SAA or	253350KAW or
	AC CORD	AS-SAA	253351HIT
P9001	AC CORD	AS-CCEE	253309HIT
P9001	AC CORD	AC-UC-2	253296HIT

PC BOARD PARTS LIST

REF NO.	NAME	DESCRIPTION	PART NO.
U1	DSP AND MICROPROCESSOR PC BOARD (NADG-7636-1B-/B/1C/1D/1E/1F)		
REF NO.	NAME	DESCRIPTION	PART NO.
Q3001	IC	BD3811K1	22241761R3
Q3101	IC	NJM4565V	22241554R2
Q3113	IC	NJM4565V	22241554R2
Q3201	IC	NJM4565V	22241554R2
Q8001	IC	MPD784225GC-182-8BT	22241875R3
Q8301	IC	NJM4565V	22241554R2
Q8302	IC	NJM4565V	22241554R2
Q8303	IC	NJM4565V	22241554R2
Q8304	IC	NJM4565V	22241554R2
Q8305	IC	NJM4565V	22241554R2
Q8306	IC	NJM4565V	22241554R2
Q8307	IC	NJM4565V	22241554R2
Q8308	IC	NJM4565V	22241554R2
Q8309	IC	NJM4565V	22241554R2
Q8401	IC	AK4586	22241620R3
Q8451	IC	TC7WU04FU	22240935R2
Q8501	IC	CS493292-CL	22241455R2
Q8601	IC	TC74VHC574FT	22274574ER2TO
Q8602	IC	TC74VHC574FT	22274574ER2TO
Q8603	IC	TC74VHC74FT	22274074ER2TO
Q8611	IC	MX27L2000TC-12	18093002618AD
(Q8611)	IC	MX27L2000TC-12	(22241809R3)
Q8651	IC	TC74VHC541FT	22274541ER2TO
Q8671	IC	TC74HCT7007AF	222740077R2TO
Q8691	IC	BA33C25FP	22241778R2
Q8801	IC	BU1923F	22241297R2
Q1101	TR	2SC4617	2216540R2
Q3111	TR	RN1441	2215410R2
Q3112	TR	RN1441	2215410R2
Q3114	TR	RN1441	2215410R2
Q3115	TR	RN1441	2215410R2
Q3116	TR	DTA114EE	2216710R2
Q3202	TR	DTA114EE	2216710R2
Q3203	TR	RN1441	2215410R2
Q8023	TR	DTA124EE	2216490R2
Q8060	TR	DTC144EE	2216390R2
Q8081	TR	2SA1774	2216410R2
Q8082	TR	DTC114EE	2216730R2
Q8851	TR	2SC4617	2216540R2
D3001	ZENER D	UDZ6.8B or	224490680R2 or
	ZENER D	UDZS6.8B	224550680R2
D3002	ZENER D	UDZ6.8B or	224490680R2 or
	ZENER D	UDZS6.8B	224550680R2
D3111	C-DIODE	1SS355	223269R2
D3201	C-DIODE	1SS355	223269R2
D3202	C-DIODE	1SS355	223269R2
D8001	C-DIODE	1SS355	223269R2
D8002	C-DIODE	1SS355	223269R2
D8023	C-DIODE	1SS355	223269R2
D8024	ZENER D	UDZ5.1B	224490510R2
D8060	C-DIODE	1SS355	223269R2
D8061	C-DIODE	1SS355	223269R2
D8062	ZENER D	UDZ7.5B	224490750R2
D8401	C-DIODE	1SS355	223269R2
D8402	C-DIODE	1SS355	223269R2

D8851	C-DIODE	ISS355	223269R2
D8852	C-DIODE	ISS355	223269R2
L8001	CHOKE COIL	NCH-1479	231237K470R2
L8401	CHOKE COIL	NCH-1471	231237M022R2
L8402	CHOKE COIL	NCH-1471	231237M022R2
L8403	CHOKE COIL	NCH-1471	231237M022R2
L8404	CHOKE COIL	NCH-1471	231237M022R2
L8451	CHOKE COIL	NCH-1479	231237K470R2
L8501	CHOKE COIL	NCH-1471	231237M022R2
L8502	CHOKE COIL	NCH-1471	231237M022R2
L8601	CHOKE COIL	NCH-1479	231237K470R2
L8691	CHOKE COIL	NCH-1479	231237K470R2
L8801	CHOKE COIL	NCH-1477	231237K220R2
X8001	CRYSTAL	HC-49/U03C12.500MHz	3010362R2
X8451	CERA LOCK	CSTCV12.2MTJ0C4	3010324R2
X8801	CRYSTAL	HC-49/U03C4.332MHz	3010332R2
C1002	VR C	CE04W50V-3.3M(VR)	394680337
C1003	VR C	CE04W50V-2.2M(VR)	394680227
C3013	VX C	CE04W16V-10M(VX)	393341007
C3014	VX C	CE04W16V-10M(VX)	393341007
C3015	VX C	CE04W16V-10M(VX)	393341007
C3016	VX C	CE04W16V-10M(VX)	393341007
C3017	VX C	CE04W16V-10M(VX)	393341007
C3018	VX C	CE04W16V-10M(VX)	393341007
C3021	VR C	CE04W16V-10M(VR)	394641007
C3022	VR C	CE04W16V-10M(VR)	394641007
C3023	MY C	MY92-50V-472J	371124724
C3024	MY C	MY92-50V-472J	371124724
C3025	MMT C	MMT50V-224J	375522244
C3026	MMT C	MMT50V-224J	375522244
C3027	MMT C	MMT50V-224J	375522244
C3028	MMT C	MMT50V-224J	375522244
C3029	MMT C	MMT50V-154J	375521544
C3030	MMT C	MMT50V-154J	375521544
C3031	MMT C	MMT50V-154J	375521544
C3032	MMT C	MMT50V-154J	375521544
C3111	VX C	CE04W16V-10M(VX)	393341007
C3112	VX C	CE04W16V-10M(VX)	393341007
C3113	VX C	CE04W16V-10M(VX)	393341007
C3115	TF C	ECQ-B50V-103J	374721034
C3116	VX C	CE04W16V-47M(VX)	393344707
C3118	VR C	CE04W50V-2.2M(VR)	394680227
C3121	CERA C	CK45F50V-223Z	335622230
C3122	CERA C	CK45F50V-223Z	335622230
C3201	VR C	CE04W16V-10M(VR)	394641007
C3202	VR C	CE04W16V-10M(VR)	394641007
C3203	VR C	CE04W16V-10M(VR)	394641007
C3206	VR C	CE04W16V-10M(VR)	394641007
C3207	VR C	CE04W16V-10M(VR)	394641007
C8001	VR C	CE04W6.3V-100M(VR)	394621017
C8003	EDL C	FMC0H104Z	3000120
C8004	VR C	CE04W6.3V-100M(VR)	394621017
C8059	VR C	CE04W50V-1.0M(VR)	394680107
C8070	TRIMMER	NTC-45P10	3060011
C8404	VR C	CE04W6.3V-47M(VR)	394624707
C8406	VR C	CE04W6.3V-220M(VR)	394622217
C8410	VR C	CE04W16V-22M(VR)	394642207
C8411	VX C	CE04W16V-10M(VX)	393341007
C8412	VX C	CE04W16V-10M(VX)	393341007
C8414	VR C	CE04W6.3V-47M(VR)	394624707
C8421	VX C	CE04W16V-47M(VX)	393344707
C8422	VX C	CE04W16V-47M(VX)	393344707
C8423	VX C	CE04W16V-10M(VX)	393341007
C8424	VX C	CE04W16V-10M(VX)	393341007
C8425	VX C	CE04W16V-47M(VX)	393344707
C8426	VX C	CE04W16V-47M(VX)	393344707
C8503	VR C	CE04W6.3V-47M(VR)	394624707
C8507	VR C	CE04W6.3V-47M(VR)	394624707
C8604	VR C	CE04W6.3V-47M(VR)	394624707
C8692	VR C	CE04W6.3V-47M(VR)	394624707
C8693	VR C	CE04W6.3V-47M(VR)	394624707
C8801	VR C	CE04W6.3V-100M(VR)	394621017
C8806	VR C	CE04W6.3V-100M(VR)	394621017
P1001A	SOCKET	NSCT-15P1609	25051822
P3001	JACK	NPJ-6PDBL159	25045300

P3004	PIN JACK	NPJ-1PDBL382	25045567
P3111	SOCKET	NSCT-12P1027	25051237
P3112	SOCKET	NSCT-14P1029	25051239
P3113	SOCKET	NSCT-12P1027	25051237
P5008	PLUG	NPLG-2P83	25055099
P7001A	PLUG	NPLG-11P139	25055155
P8006	PLUG	NPLG-2P29	25055038
P8151A	PLUG	NPLG-14P142	25055158
P8153	SOCKET	NSCT-7P2241	25052344
P8403A	PLUG	NPLG-2P130	25055146
P8404A	PLUG	NPLG-3P131	25055147
P8711	ST JACK	LGY2502-0200C	25045696
P8852A	PLUG	NPLG-2P130	25055146
P8853	PLUG	NPLG-2P29	25055038
U2	DISPLAY PC BOARD (NADIS-7637-1B/1C/1D/1E/1F)		
REF NO.	NAME	DESCRIPTION	PART NO.
Q7001	FL TUBE	HNV-12SS12T	212228A
Q7001A	HOLDER	(FL)	27191169
Q7002	IC	MPD780232GC-070-8BT	22241814R3
Q7003	REMO SENS	PIC-37043TE2	241337
Q7003A	SPACER		27270431
Q7004	TR	DTC114EE	2216730R2
Q7005	TR	DTC114EE	2216730R2
Q7006	TR	DTC114EE	2216730R2
Q7007	TR	DTC114EE	2216730R2
Q7008	TR	DTC114EE	2216730R2
Q7009	TR	DTC114EE	2216730R2
Q7010	TR	DTC144EE	2216390R2
D7001	ZENER D	UDZ4.7B	224490470R2
D7002	DIODE	GP104003E	22380035
D7005	LED	SEL2410G-C or	225318C or
	LED	SEL2410G-D	225318D
D7006	LED	SEL2410G-C or	225318C or
	LED	SEL2410G-D	225318D
D7007	LED	SEL2410G-C	225318C
D7007	LED	SEL2410G-D or	225318D or
D7008	LED	SEL2910A-TP6	225390
X7001	CERA LOCK	CST5.00MGW	3010242
C7005	ELECT C	CE04W6.3V-100M(S)	353721019
C7012	ELECT C	CE04W6.3V-100M(S)	353721019
C7015	ELECT C	CE04W50V-22M	355782209
S7001	R ENCODE	EC16B2420	25065606
S7003	PUSH SW	NPS-111-S662	25035699
S7004	PUSH SW	NPS-111-S662	25035699
S7005	PUSH SW	NPS-111-S662	25035699
S7006	PUSH SW	NPS-111-S662	25035699
S7007	PUSH SW	NPS-111-S662	25035699
S7008	PUSH SW	NPS-111-S662	25035699
S7009	PUSH SW	NPS-111-S662	25035699
S7010	PUSH SW	NPS-111-S662	25035699
S7011	PUSH SW	NPS-111-S662	25035699
S7012	PUSH SW	NPS-111-S662	25035699
S7013	PUSH SW	NPS-111-S662	25035699
S7014	PUSH SW	NPS-111-S676	25035713R2
P7001	SOCKET AS	NSAS-22P1050	2002E392220
P7002	SOCKET AS	NSAS-10P1078	200EE391013
U3	STANDBY SWITCH PC BOARD (NASW-7638-1B/1C/1D/1E/1F)		
REF NO.	NAME	DESCRIPTION	PART NO.
D7003	LED	SEL2110R-TP6	225389
D7004	LED	SEL2910A-TP6	225390
S7002	PUSH SW	NPS-111-S662	25035699
U4	POWER SUPPLY PC BOARD (NAPS-7640-1B/1C/1D/1E/1F)		
REF NO.	NAME	DESCRIPTION	PART NO.
Q5801	TR	DTA114EE	2216710R2
Q5802	TR	DTA114EE	2216710R2
Q5803	TR	DTC123JE	2216740R2
Q5804	TR	DTC123JE	2216740R2
Q5805	TR	DTC123JE	2216740R2
Q9001	TR	DTC123JE	2216740R2
D5801	C-DIODE	1SS355	223269R2
D5802	C-DIODE	1SS355	223269R2
D5803	C-DIODE	1SS355	223269R2
D9001	DIODE	S1NB60-4062	22380318R2
D9002	C-DIODE	1SS355	223269R2
L5701	S COIL	S-1.3C	231176S

L5702	S COIL	S-1.3C	231176S
L5703	S COIL	S-1.3C	231176S
L5704	S COIL	S-1.3C	231176S
L5705	S COIL	S-1.3C	231176S
T9002	P TRANS	NPT-1358D	2301381
T9002	P TRANS	NPT-1358P	2301382
T9002	P TRANS	NPT-1358DG	2301383
C5701	MMT C	MMT50V-104J	375521044
C5702	MMT C	MMT50V-104J	375521044
C5703	MMT C	MMT50V-104J	375521044
C5704	MMT C	MMT50V-104J	375521044
C5705	MMT C	MMT50V-104J	375521044
C9001	IS C	RE275V-103M	3500196S
C9003	VR C	CE04W25V-470M(VR)	394654717
R5701	METAL O R	RS1/2WBJ-10	443521004
R5702	METAL O R	RS1/2WBJ-10	443521004
R5703	METAL O R	RS1/2WBJ-10	443521004
R5703	METAL O R	RS1/2WBJ-10	443521004
R5704	METAL O R	RS1/2WBJ-10	443521004
R5705	METAL O R	RS1/2WBJ-10	443521004
R5711	METAL R	RNU1WCJ-4.7	453630474
R5712	METAL R	RNU1WCJ-4.7	453630474
R5713	METAL R	RNU1WCJ-4.7	453630474
R5714	METAL R	RNU1WCJ-4.7	453630474
R5715	METAL R	RNU1WCJ-4.7	453630474
R5901	METAL O R	RS1/2WBJ-390	443523914
R5902	METAL O R	RS1/2WBJ-390	443523914
R9001	SOLID R	RC1/2GFKUL-3.3M	431533355
R9002	METAL O R	RS1/2WBJ-22	443522204
R9003	METAL R	RNU1/2WCJ-8.2	453530824
RL5801	RELAY	NRL-2P5A-DC24-164 or	25065636 or
	RELAY	NRL-2P5A-DC24-098 or	25065517 or
	RELAY	NRL-2P5A-DC24-129 or	25065563 or
	RELAY	NRL-2P5A-DC24-142 or	25065586 or
RL5802	RELAY	NRL-1P3A-DC24-165	25065637
RL5803	RELAY	NRL-2P5A-DC24-164 or	25065636 or
	RELAY	NRL-2P5A-DC24-098 or	25065517 or
	RELAY	NRL-2P5A-DC24-129 or	25065563 or
	RELAY	NRL-2P5A-DC24-142 or	25065586 or
RL9001	RELAY	NRL-1P5A-DC12-161 or	25065633 or
	RELAY	NRL-1P5A-DC12-139	25065583
JL5001A	WIRE HOL	NSCT-6P877	25051090
JL5002A	WIRE HOL	NSCT-4P895	25051108
JL5003A	WIRE HOL	NSCT-6P897	25051110
JL5801B	WIRE TRAP	NPLG-5P588	25055626
JL9001A	WIRE HOL	NSCT-3P874	25051087
P5701	TRM	NTM-6PDML256	25060325
P5702	TRM	NTM-4PDML252	25060321
P9001A	AC INLET	NPLG-2P956	25056006
P9001A	AC INLET	NPLG-2P977	25056027
P9001A	AC INLET	NPLG-2P977	25056027
P9001C	CORE	NFY-25 BLACK	230945
P9002C	PLUG	NPLG-2P631	25055675
F9001A	FUSE HOL	NSCT-1P2031	25052133
F9001B	FUSE HOL	NSCT-1P2031	25052133
F9001C	LABEL	2.5A/125V	29360470
U5	PHONES JACK PC BOARD (NAETC-7641-1B/1C/1D/1E/1F)		
REF NO.	NAME	DESCRIPTION	PART NO.
L5901	CHOKO COIL	BLM21B222SPT	230921R2
L5902	CHOKO COIL	BLM21B222SPT	230921R2
JL5801A	WIRE HOL	NSCT-5P876	25051089
P5901	JACK	YKB26-5005	25045514
U6	CONNECTOR PC BOARD (NAETC-7642-1B)		
REF NO.	NAME	DESCRIPTION	PART NO.
P3112A	PLUG	NPLG-14P666	25055710
P5001	SOCKET	NSCT-14P1029	25051239
U7	CONNECTOR PC BOARD (NAETC-7643-1B)		
REF NO.	NAME	DESCRIPTION	PART NO.
P3111A	PLUG	NPLG-12P664	25055708
P5007	SOCKET	NSCT-12P1027	25051237
U8	CONNECTOR PC BOARD (NAETC-7644-1B)		
REF NO.	NAME	DESCRIPTION	PART NO.
P3113A	PLUG	NPLG-12P664	25055708
P5002	SOCKET	NSCT-12P1027	25051237
U12	THERMISTOR PC BOARD (NAETC-7645-1B)		

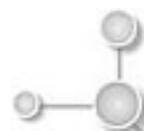

REF NO.	NAME	DESCRIPTION	PART NO.
R8851	THERMISTOR	PTH9M04BB222TS2F333	4000149
P8851	SOCKET AS	NSAS-4P0894	2002A390410
U13 MAIN PC BOARD (NAAR-7646-1B/1C)			
REF NO.	NAME	DESCRIPTION	PART NO.
Q2001	IC(REGULATOR)	TC4053BF	222840531R2TO
Q2002	IC	LA73054	22241767R2
Q2401	IC(REGULATOR)	TC4053BF	222840531R2TO
Q5401	IC	STK402-950	222123
Q8481	IC	TC7WU04FU	22240935R2
Q9502	IC	PQ12RF1	22241770
Q9503	IC(REGULATOR)	NJM78M06FA or	222780065JRC or
	IC(REGULATOR)	AN78M06F	222780065MAT
Q9504	IC(REGULATOR)	1	222780125NEC
Q9505	IC(REGULATOR)	79M12HF(NJM79M12FA)	222790125JRC
Q9506	IC(REGULATOR)	78M56	222780565
Q9507	IC	PQ05RD11	22241495
Q9508	IC(REGULATOR)	NJM78M05FA	222780055JRC
Q9509	IC(REGULATOR)	NJM7806FA	222780064JRC
Q9510	IC	PQ3RD23	22241771
Q9511	IC(REGULATOR)	MPC2925T	22278025DR2NE
U8482	PHT CP	TOTX179	24120094
Q2007	TR	DTC114EE	2216730R2
Q2402	TR	DTC114EE	2216730R2
Q2403	TR	DTC114EE	2216730R2
Q2404	TR	DTC114EE	2216730R2
Q2501	TR	HN1A01F-GR	2215915R2
Q2502	TR	HN1A01F-GR	2215915R2
Q2503	TR	2SC4617	2216540R2
Q2504	TR	2SA1774	2216410R2
Q5001	TR	2SC1622A(D18) or	2216154R2 or
	TR	2SC1622A(D17)	2216153R2
Q5002	TR	2SC1622A(D18) or	2216154R2 or
	TR	2SC1622A(D17)	2216153R2
Q5003	TR	2SC1622A(D18) or	2216154R2 or
	TR	2SC1622A(D17)	2216153R2
Q5004	TR	2SC1622A(D18) or	2216154R2 or
	TR	2SC1622A(D17)	2216153R2
Q5005	TR	2SC1622A(D18) or	2216154R2 or
	TR	2SC1622A(D17)	2216153R2
Q5501	TR	2SC4617	2216540R2
Q5502	TR	2SC4617	2216540R2
Q5503	TR	2SA1774	2216410R2
Q5504	TR	2SK365-GR	2212445
Q5505	TR	2SC4617	2216540R2
Q5507	TR	2SA950-Y	2211504
Q9501	TR	2SA950-Y	2211504
D2501	DIODE	1SS226	223266R2
D2502	DIODE	1SS226	223266R2
D2503	DIODE	1SS226	223266R2
D2504	DIODE	1SS226	223266R2
D2505	DIODE	1SS226	223266R2
D2506	DIODE	1SS226	223266R2
D5001	C-DIODE	1SS355	223269R2
D5002	C-DIODE	1SS355	223269R2
D5003	C-DIODE	1SS355	223269R2
D5004	C-DIODE	1SS355	223269R2
D5005	C-DIODE	1SS355	223269R2
D5501	ZENER D	UDZS5.1B	224550510R2
D5501	ZENER D	RD5.1SB2 or	224370512R2 or
	C-DIODE	1SS355	223269R2
D9501	DIODE	RBV602	22380038
D9501A	HEAT SINK	RAD-083	27160271
D9501B	SCREW	3P+10FN(BC)	82143010
D9502	DIODE	RL1N4003 or	22380260 or
	DIODE	GP104003E	22380035
D9503	DIODE	RL1N4003 or	22380260 or
	DIODE	GP104003E	22380035
D9504	ZENER D	UDZS27B or	224552700R2 or
	ZENER D	RD27SB	224372700R2
D9505	DIODE	RL1N4003 or	22380260 or
	DIODE	GP104003E	22380035
D9506	DIODE	RBV402 or	22380022F or
	DIODE	D3SBA20 or	22380271F
D9507	DIODE	RL1N4003 or	22380260 or

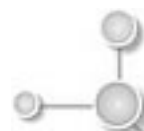

	DIODE	GP104003E	22380035
D9508	DIODE	RBV402 or	22380022F or
	DIODE	D3SBA20	22380271F
L8481	EMIFIL	BK1608LM182-T	230958R1
L8482	EMIFIL	BK1608LM182-T	230958R1
U8483	PHT CP	TORX179	24120095
C2011	VR C	CE04W6.3V-100M(VR)	394621017
C2014	VR C	CE04W6.3V-100M(VR)	394621017
C2016	VR C	CE04W6.3V-100M(VR)	394621017
C2018	VR C	CE04W6.3V-100M(VR)	394621017
C2020	VR C	CE04W6.3V-100M(VR)	394621017
C2022	VR C	CE04W6.3V-100M(VR)	394621017
C2023	VR C	CE04W6.3V-220M(VR)	394622217
C2027	VR C	CE04W6.3V-1000M(VR)	394621027
C2029	VR C	CE04W6.3V-1000M(VR)	394621027
C2030	VR C	CE04W6.3V-1000M(VR)	394621027
C2031	VR C	CE04W6.3V-1000M(VR)	394621027
C2032	VR C	CE04W6.3V-1000M(VR)	394621027
C2401	VR C	CE04W16V-100M(VR)	394641017
C2501	VR C	CE04W6.3V-1000M(VR)	394621027
C2502	VR C	CE04W6.3V-1000M(VR)	394621027
C2503	VR C	CE04W6.3V-1000M(VR)	394621027
C2504	VR C	CE04W6.3V-1000M(VR)	394621027
C2505	VR C	CE04W16V-100M(VR)	394641017
C5011	VX C	CE04W16V-22M(VX)	393342207
C5012	VX C	CE04W16V-22M(VX)	393342207
C5013	VX C	CE04W16V-22M(VX)	393342207
C5014	VX C	CE04W16V-22M(VX)	393342207
C5015	VX C	CE04W16V-22M(VX)	393342207
C5021	VX C	CE04W6.3V-100M(VX)	393321017
C5022	VX C	CE04W6.3V-100M(VX)	393321017
C5023	VX C	CE04W6.3V-100M(VX)	393321017
C5024	VX C	CE04W6.3V-100M(VX)	393321017
C5025	VX C	CE04W6.3V-100M(VX)	393321017
C5405	VR C	CE04W35V-330M(VR)	394663317
C5406	VR C	CE04W35V-330M(VR)	394663317
C5501	VR C	CE04W6.3V-100M(VR)	394621017
C5502	MMT C	MMT50V-104J	375521044
C5504	VR C	CE04W16V-10M(VR)	394641007
C5506	VR C	CE04W35V-47M(VR)	394664707
C8481	VR C	CE04W6.3V-100M(VR)	394621017
C8486	VR C	CE04W6.3V-100M(VR)	394621017
C9501	MMT C	MMT50V-334J	375523344
C9502	MMT C	MMT50V-334J	375523344
C9503	ELECT C	CE69W35V-5600M	3504370
C9504	ELECT C	CE69W35V-5600M	3504370
C9505	VR C	CE04W35V-100M(VR)	394661017
C9506	VR C	CE04W50V-47M(VR)	394684707
C9511	VR C	CE04W50V-10M(VR)	394681007
C9512	VR C	CE04W50V-10M(VR)	394681007
C9514	VR C	CE04W50V-10M(VR)	394681007
C9516	VR C	CE04W50V-10M(VR)	394681007
C9517	MMT C	MMT50V-334J	375523344
C9518	MMT C	MMT50V-334J	375523344
C9519	VR C	CE04W16V-4700M(VR)	394644727S
C9521	VR C	CE04W16V-1000M(VR)	394641027S
C9522	VR C	CE04W50V-10M(VR)	394681007
C9524	VR C	CE04W50V-10M(VR)	394681007
C9526	VR C	CE04W50V-10M(VR)	394681007
C9528	VR C	CE04W50V-10M(VR)	394681007
C9529	MMT C	MMT50V-334J	375523344
C9530	MMT C	MMT50V-334J	375523344
C9531	VR C	CE04W10V-10000M(VR)	394631037S
C9533	VR C	CE04W6.3V-470M(VR)	394624717
C9535	VR C	CE04W50V-10M(VR)	394681007
R2502	METAL O R	RS1/2WBJ-330	443523314
R2504	METAL O R	RS1/2WBJ-330	443523314
R5041	METAL R	RNU2WCJ-0.22	452732294F
R5042	METAL R	RNU2WCJ-0.22	452732294F
R5043	METAL R	RNU2WCJ-0.22	452732294F
R5044	METAL R	RNU2WCJ-0.22	452732294F
R5045	METAL R	RNU2WCJ-0.22	452732294F
R5401	METAL O R	RS1/2WBJ-47	443524704
R5402	METAL O R	RS1/2WBJ-33	443523304
R5403	METAL O R	RS1WBJ-2.2K	443622224

R5515	METAL O R	RS1WBJ-33	443623304
R5516	METAL O R	RS1WBJ-33	443623304
R9501	METAL R	RNU1WCJ-6.8	453630684
R9502	METAL R	RNU1/2WCJ-6.8	453530684
R9503	METAL R	RNU1/2WCJ-6.8	453530684
R9504	METAL O R	RS1/2WBJ-22	443522204
R9505	METAL O R	RS1/2WBJ-2.2K	443522224
R9507	METAL O R	RS1/2WBJ-56	443525604
R9508	METAL R	RNU1/2WCJ-2.2	453530224
R9509	METAL R	RNU1/2WCJ-2.2	453530224
R9510	METAL R	RNU1/2WCJ-2.2	453530224
R9511	METAL R	RNU1/2WCJ-1	453530104
R9512	METAL R	RNU1WCJ-0.22	453632294
R9513	METAL O R	RS1WBJ-10	443621004
R9514	METAL O R	RS1/2WBJ-22	443522204
J5301B	HOLDER	HOLDER(CLAMP)	27190540-1
J5301C	HOLDER	HOLDER(CLAMP)	27190540-1
JL5001B	WIRE TRAP	NPLG-6P589	25055627
JL5002B	SOCKET	NSCT-4P96	25050268
JL5003B	SOCKET	NSCT-6P98	25050270
JL9001B	WIRE TRAP	NPLG-3P586	25055624
JL9002B	WIRE HOL	NSCT-7P898	25051111
JL9003B	WIRE HOL	NSCT-6P897	25051110
P2001	SOCKET AS	NSAS-20P1053	2009990750UL
P2001A	PLUG	NPLG-10P357	25055374
P2001B	SOCKET AS	NSAS-8P1048	2002E390830
P2001C	PLUG	NPLG-4P132	25055148
P2002	SOCKET AS	NSAS-24P1052	2009990749UL
P2003	SOCKET	NSCT-4P1537	25051750
P2004	PIN JACK	NPJ-1PDYE368	25045547
P2005	PIN JACK	NPJ-3PDB401	25045590
P2501	SOCKET	NSCT-21P2557	25052660
P5001A	PLUG	NPLG-14P666	25055710
P5002A	PLUG	NPLG-12P664	25055708
P5005A	SOCKET	NSCT-12P2209 or	25052312 or
	SOCKET	NSCT-12P2403	25052506
P5006A	SOCKET	NSCT-4P2201 or	25052304 or
	SOCKET	NSCT-4P2395	25052498
P5007A	PLUG	NPLG-12P664	25055708
P5010	RETAINER	(BUS)	27141818
P8404	SOCKET AS	NSAS-6P1026	2009990732UL
F9501A	FUSE HOL	NSCT-1P2031	25052133
F9501B	FUSE HOL	NSCT-1P2031	25052133
U14	TRANSFORMER TERMINAL PC BOARD (NAPS-7647-1B)		
REF NO.	NAME	DESCRIPTION	PART NO.
JL9002A	WIRE HOL	NSCT-7P898	25051111
JL9003A	WIRE HOL	NSCT-6P897	25051110
P9002	SOCKET AS	NSAS-4P0994	2009990712AUL
U15	DVD CONNECTOR PC BOARD (NAETC-7649-1B/1C)		
REF NO.	NAME	DESCRIPTION	PART NO.
CN21	SOCKET	NSCT-30P2264	25052367
CN22	SOCKET	NSCT-30P2264	25052367
CN51	SOCKET-AS	NSAS-10P0181	2006341015UL
CN61	SOCKET	NSCT-17P2251	25052354
P2002A	PLUG	NPLG-12P359	25055376
P5003	SOCKET AS	NSAS-20P1046	200AE392020
P5004	SOCKET AS	NSAS-30P1047	200AE393020
P51A	PLUG	NPLG-5P352	25055369
P8151	SOCKET AS	NSAS-28P1000	2002E392825

EXPLODED VIEW PARTS LIST OF MECHANISM

DVD MECHANISM: DB-VLD304

The mechanical parts with no part number in the exploded views are not supplied.

REF. NO.	DESCRIPTION	PART NO.
1a	Loading switch PC board	VNP1836
1b	Push Switch	VSK1011
1c	Connector KR (2P)	S2B-PH-K
1d	Connector KR (5P)	S5B-PH-K
2	Traverse mechanism assy	VXX2782
6	Flexible Flat Cable (26P)	VDA1864
8	Froating Rubber	VEB1327
9	Belt	VEB1328
		VNE2253

10	Stabilizer	VNL1917
11	Loading base	VNL1918
12	Floating base DVD	VNL1919
13	Drive Cam	VNL1921
14	Gear Pulley	VNL1922
15	Loading gear	VNL1923
16	Drive gear	VNL1925
17	Lever Switch	VNE2251
18	Clamper Plate	VNE2252
19	Bridge	VNL1924
20	Clamper	VNL1920
23	Tray ABS	

TRAVERSE UNIT

REF. NO.	DESCRIPTION	PART NO.
1	Spindle Motor	VXM1088
2	Stepping Motor	VXM1090
3	Pick-up ass'y-S	0XX8003
4	Skew Screw	VBA1080
5	Skew Spring	VBH1335
6	Guide ber	VLL1514
7	Sub Guide Bar	VLL1515
8	Hold spring	VNC1017
9	Joint Spring	VNC1019
10	Support Spring	VNC1020
12	Slider	VNL1811
13	Spacer	VNL1913
14	Joint	VNL1914
15	FFC holder	VNL1915
16	Screw	BBZ20P050FZK
17	Screw	OBA8009
18	Screw	PMA26P100FMC
19	Damper sheet	VEB1335

SCHEMATIC DIAGRAMS-1 DISPLAY SECTION

1
2
3
4
5

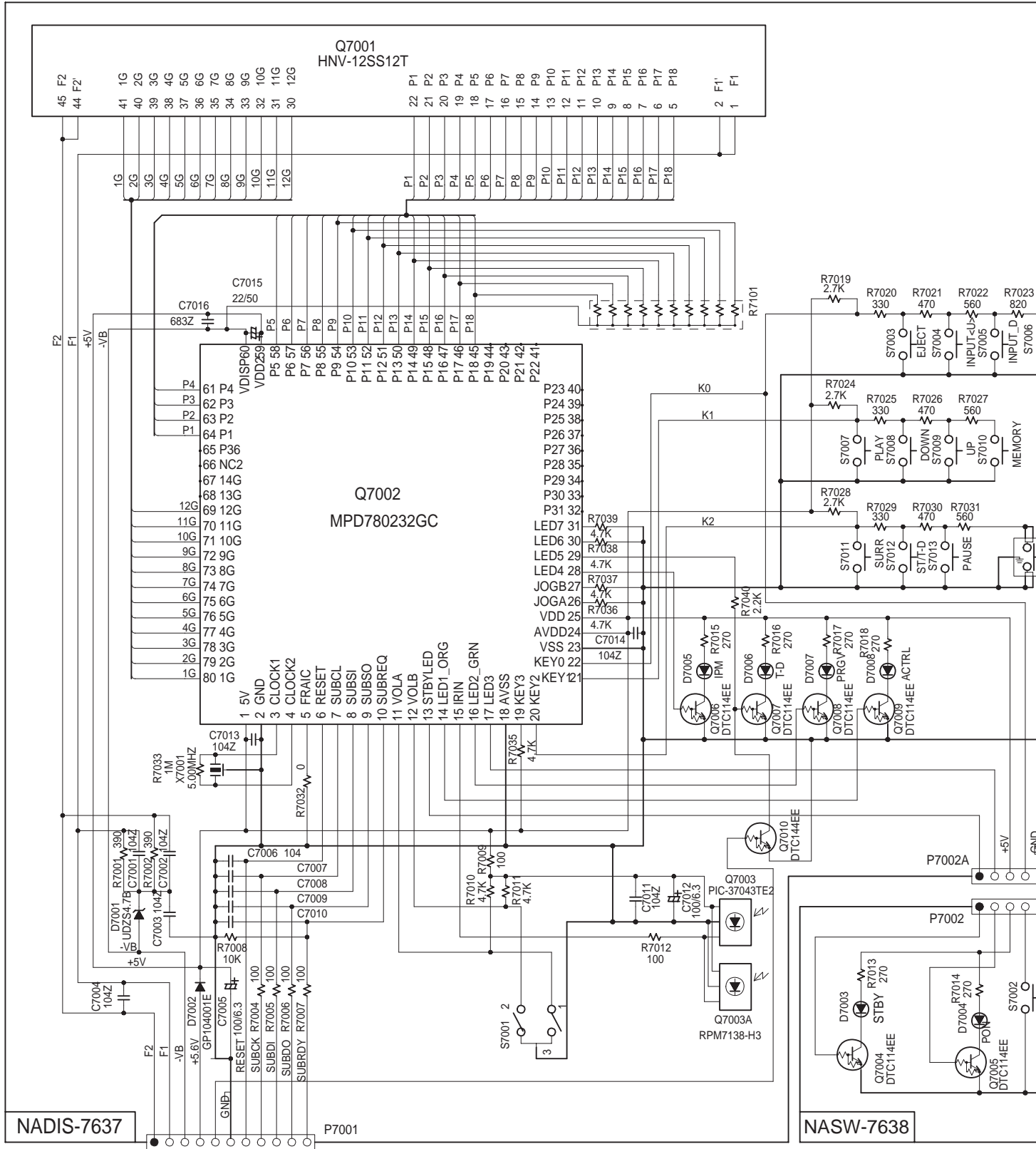

E

F

G

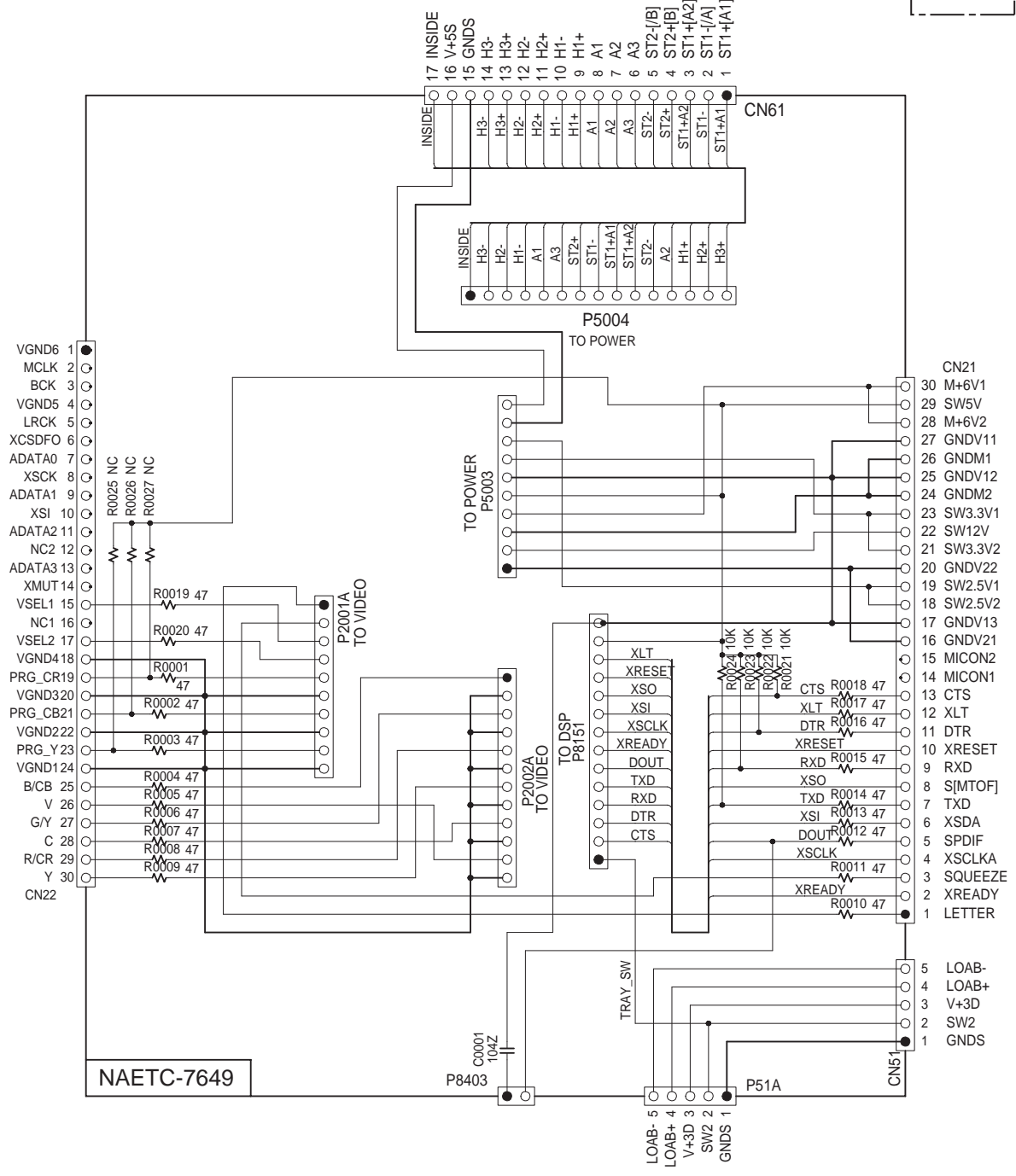
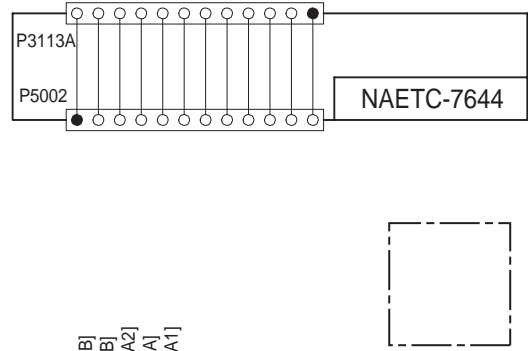
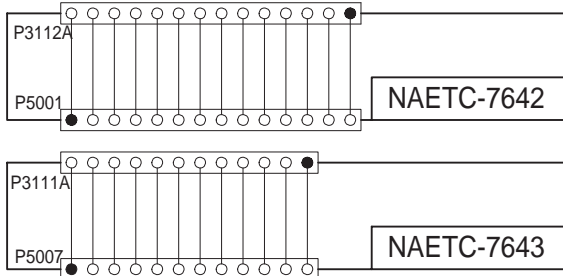

SCHEMATIC DIAGRAMS-2 DSP SECTION

NADG-7636

1

2

3

4

5

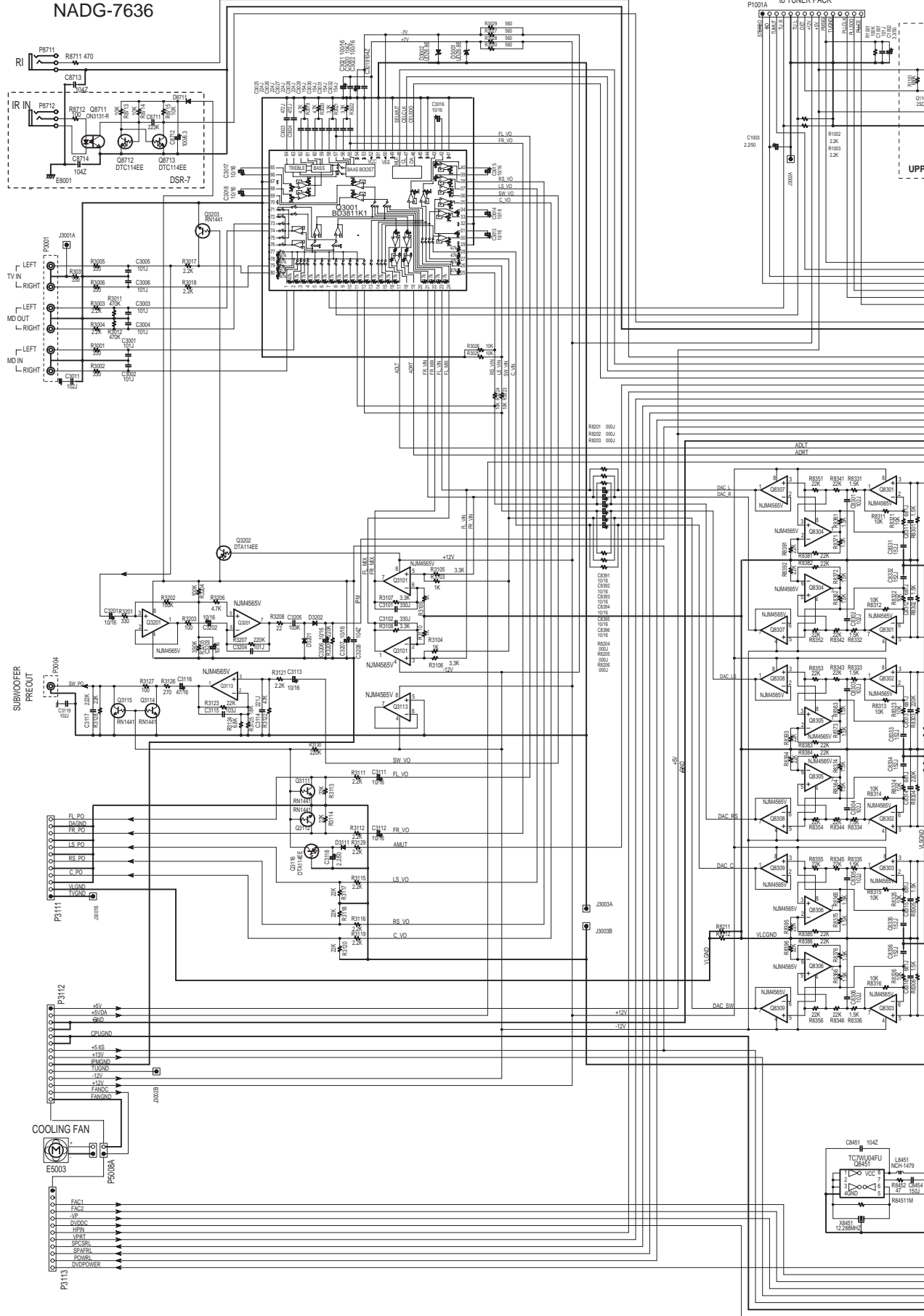

E

F

G

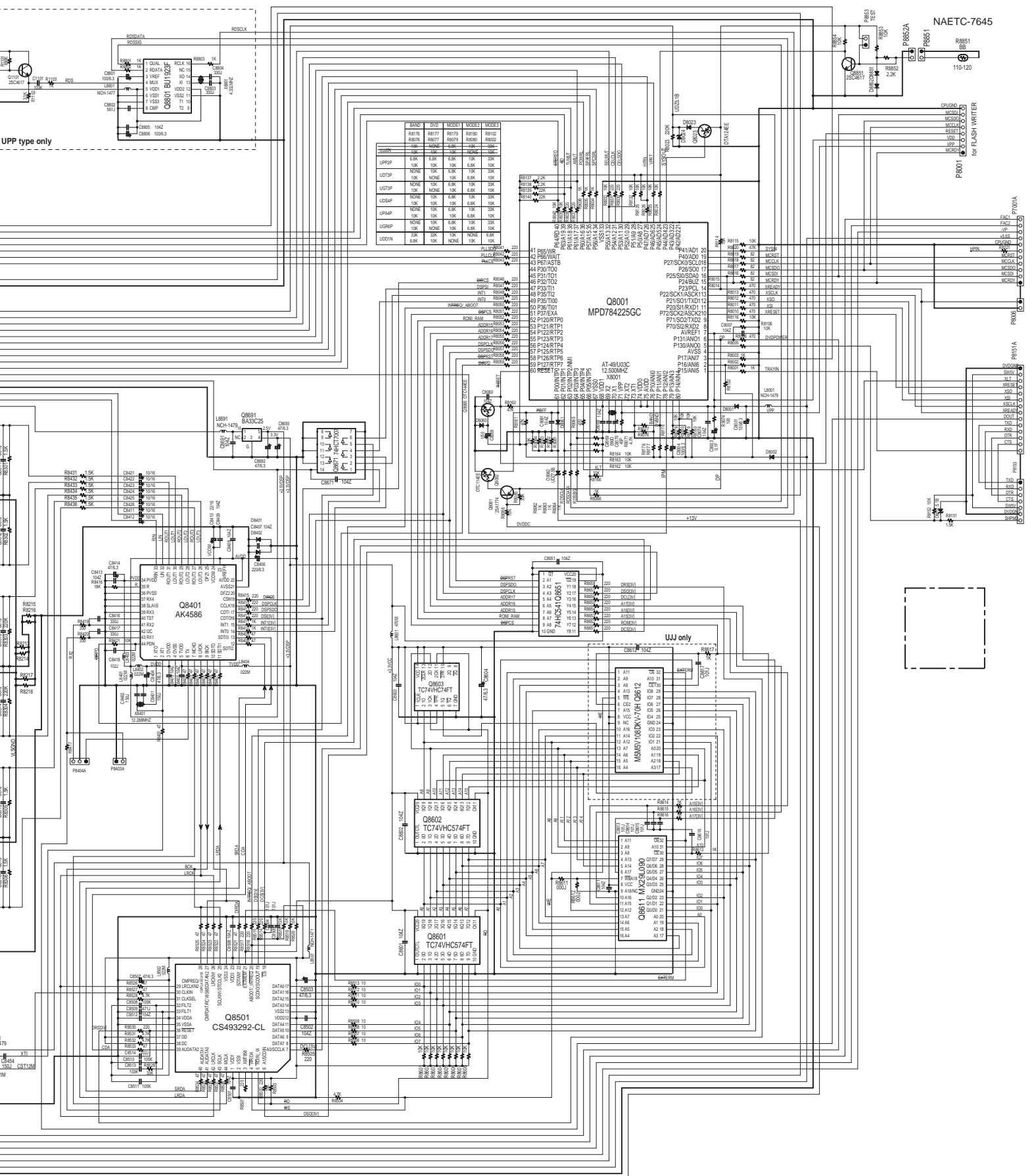

A B C
SCHEMATIC DIAGRAMS-3
AUDIO SECTION

1

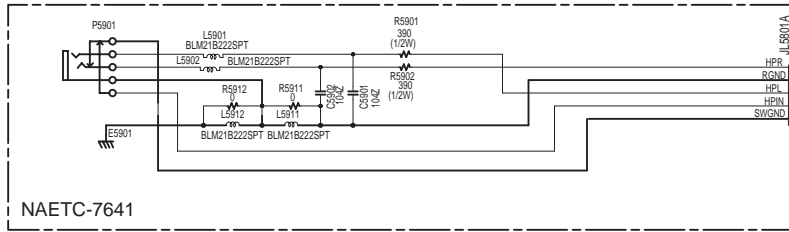

NAPS-7640

2

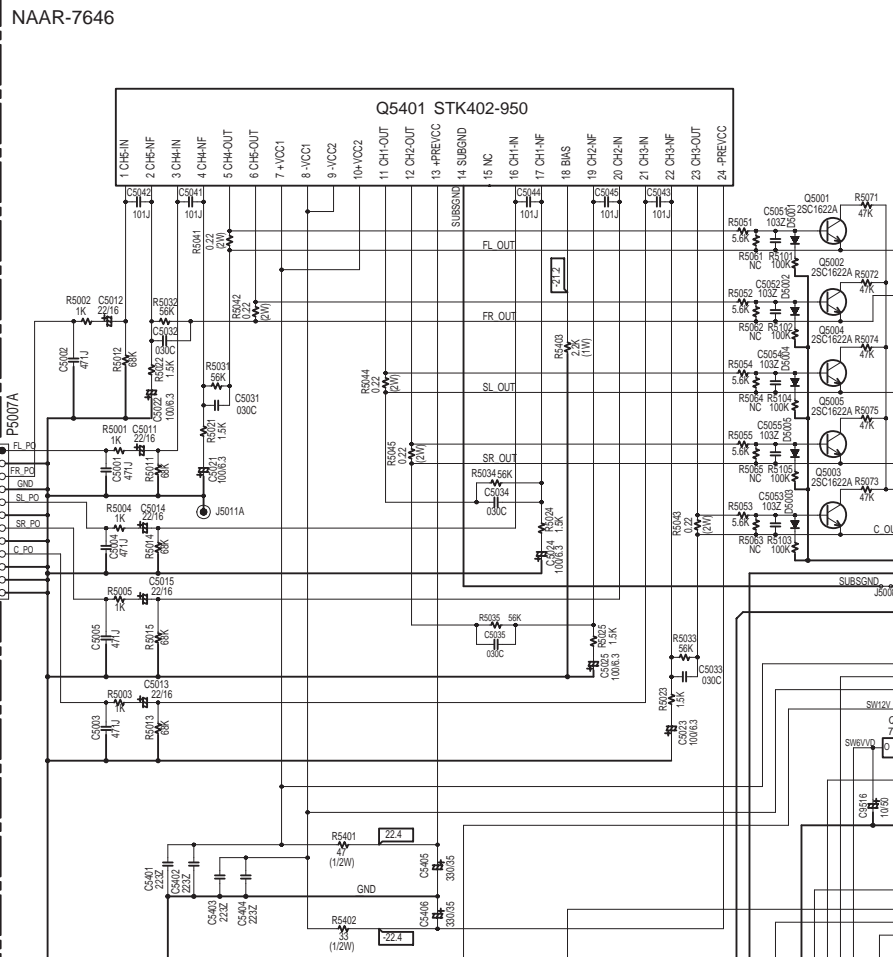

3

TO NADG-7636

4

TO DVD MECHA

TO DVD MECHA

5

TO NAETC-7649

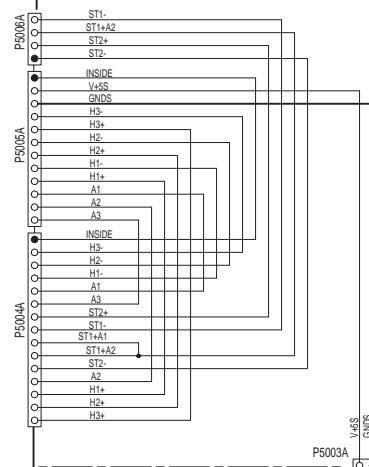

TO NAETC-7649

TO NADG-7636

TO NADG-7636

E

F

G

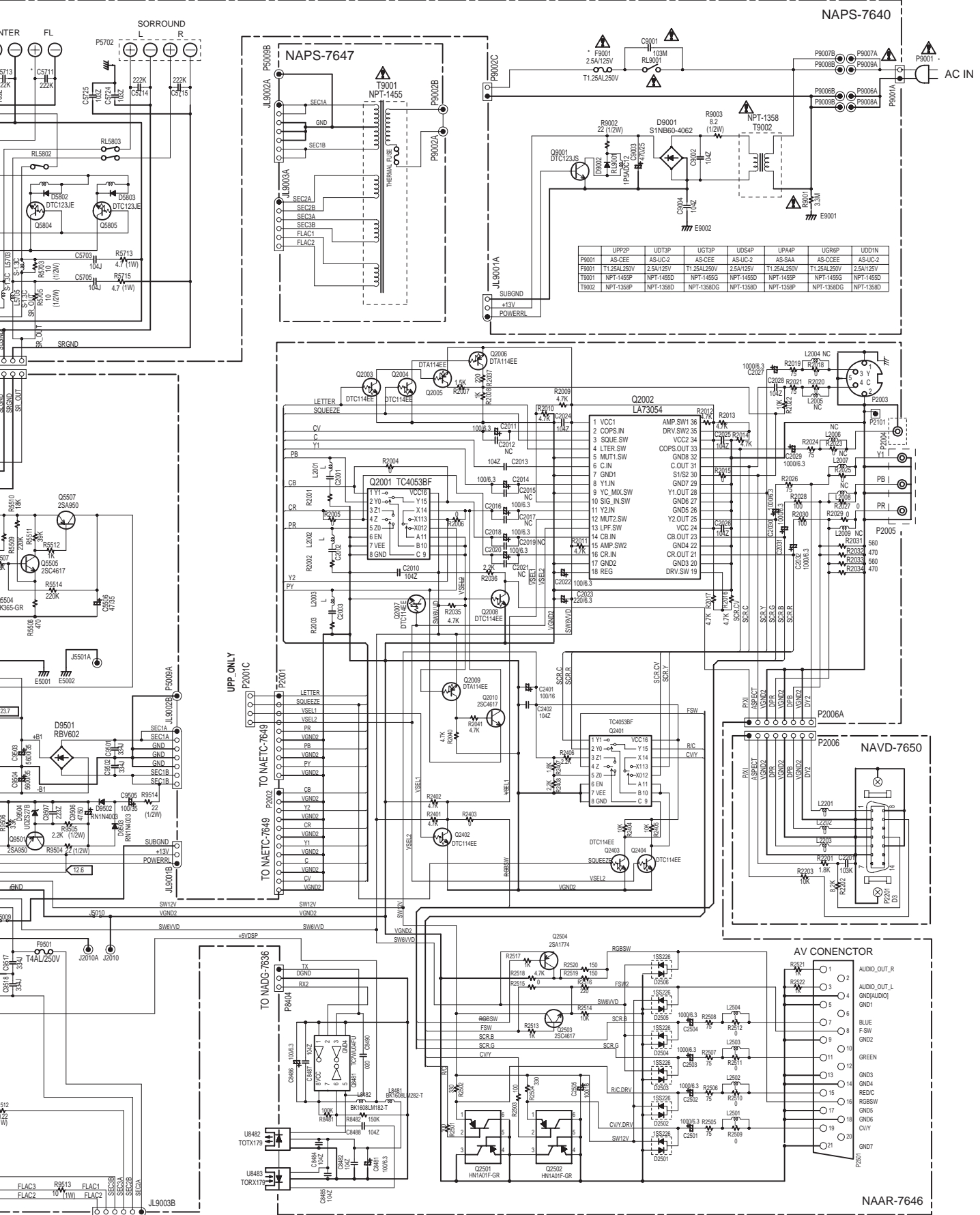

SCHEMATIC DIAGRAMS-4 DVD MAIN BOARD: DB-VPB314/XJ / DB-VPB313/XJ (1/4)

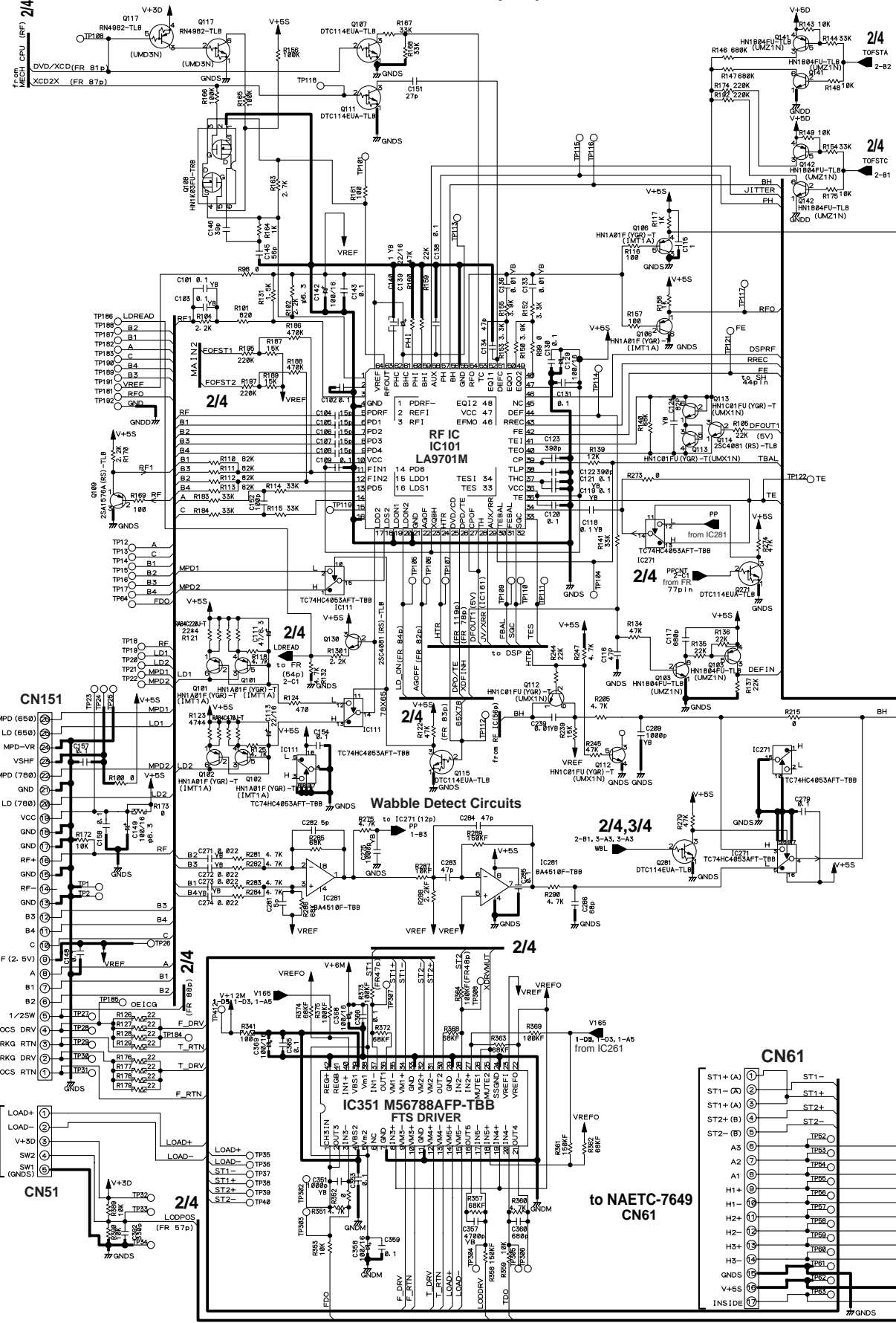

A

B

C

D

to NAETC-7649
CN51

to NAETC-7649
CN61

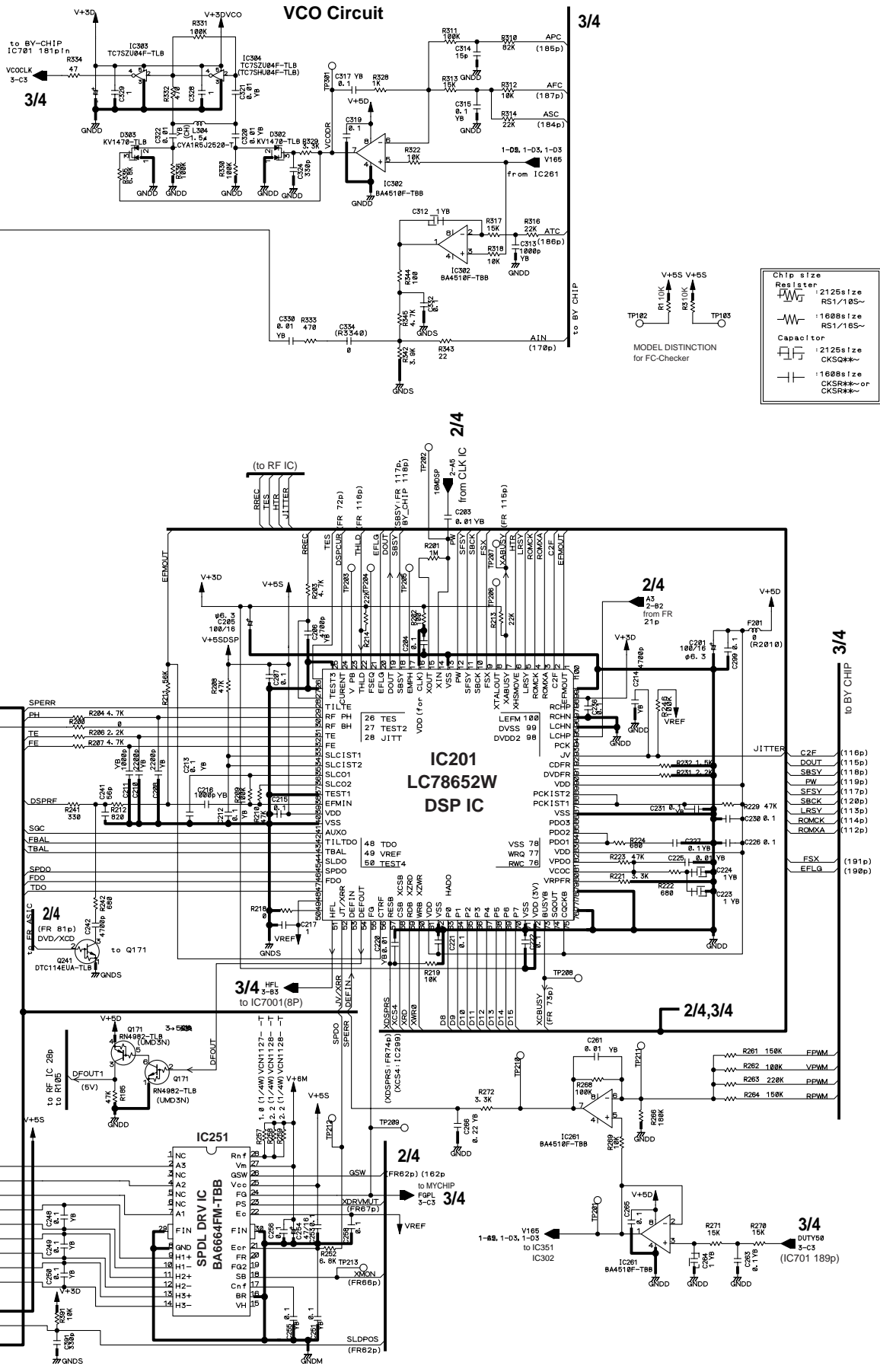

SCHEMATIC DIAGRAMS-5 DVD MAIN BOARD : DB-VPB314/XJ / DB-VPB313/XJ (2/4)

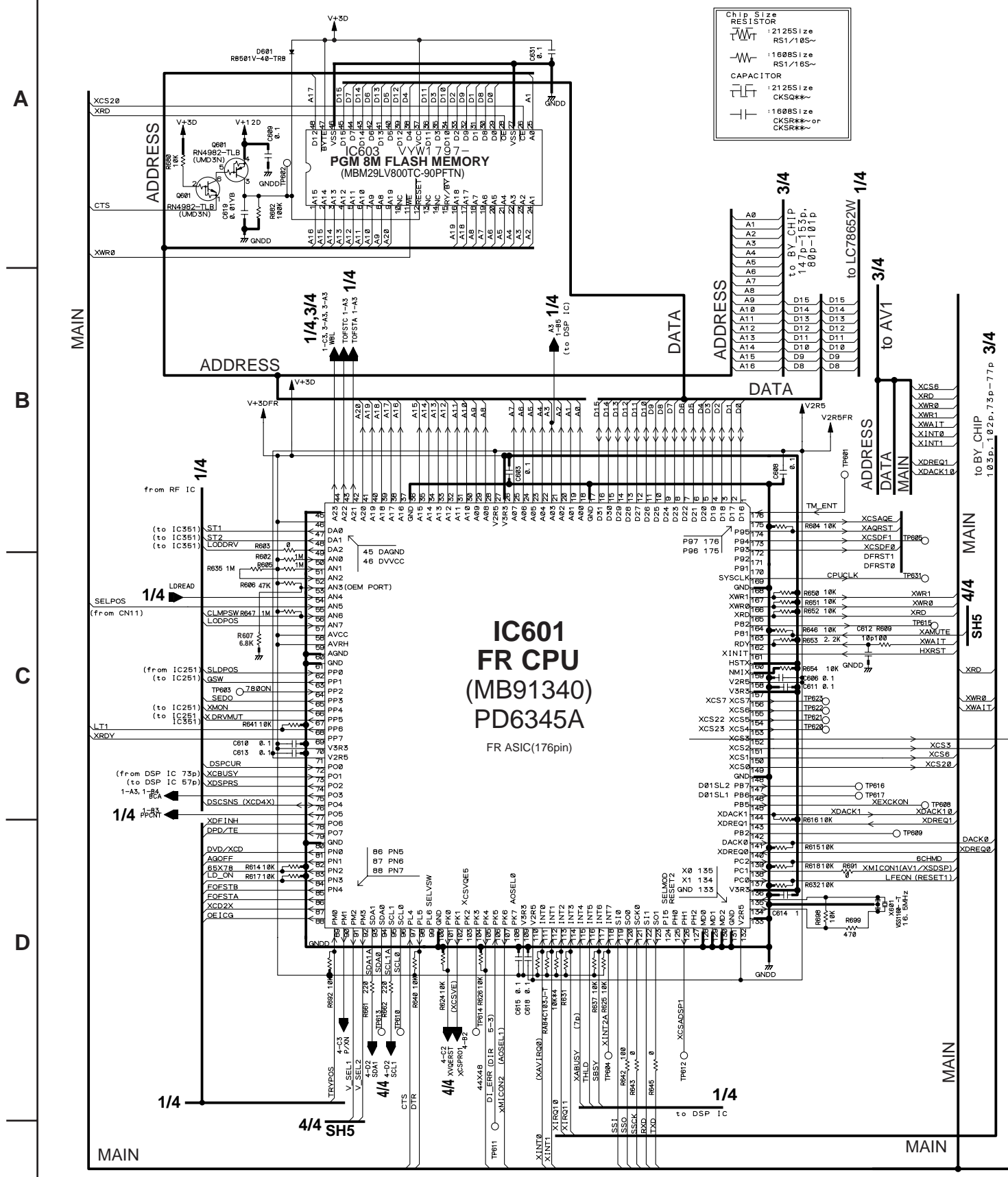

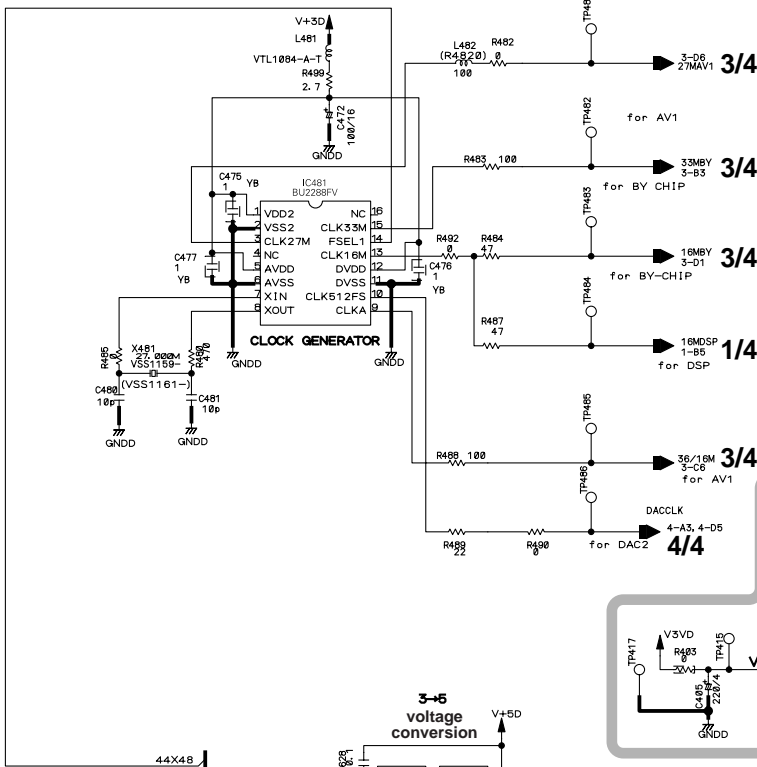

Focus offset SW

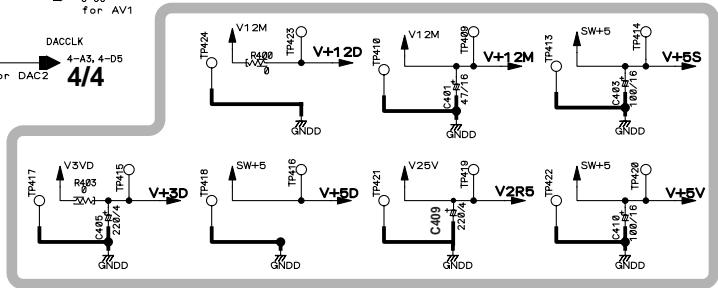
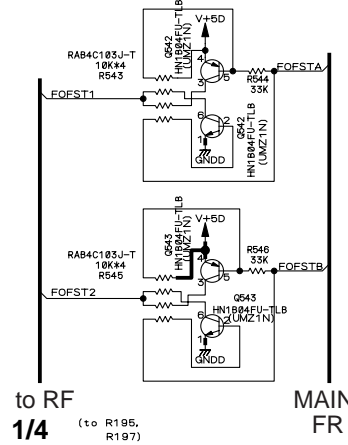

(D) : AUDIO (DIGITAL) SIGNAL ROUTE

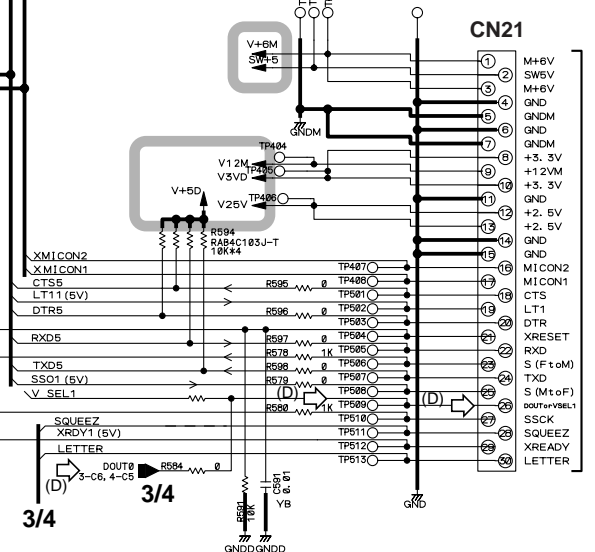
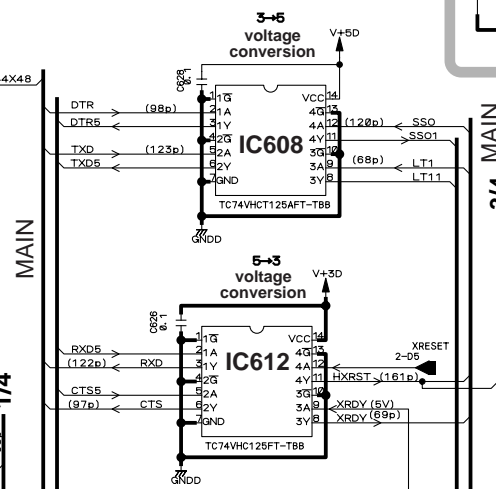

To NAETC-7649 CN21

○ : Power supply

SCHEMATIC DIAGRAMS-6

DVD MAIN BOARD: DB-VPB314/XJ / DB-VPB313/XJ (3/4)

A

B

C

D

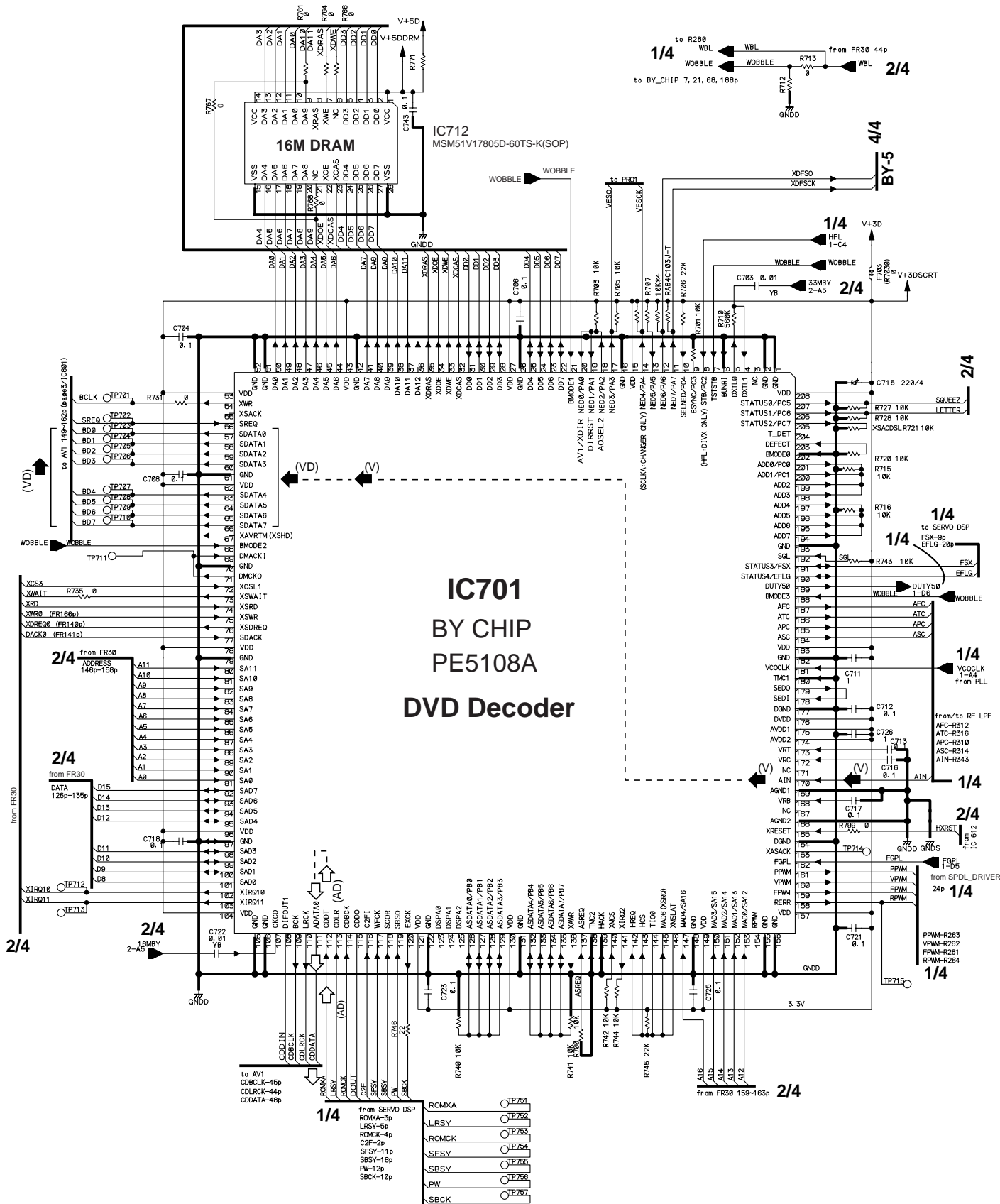

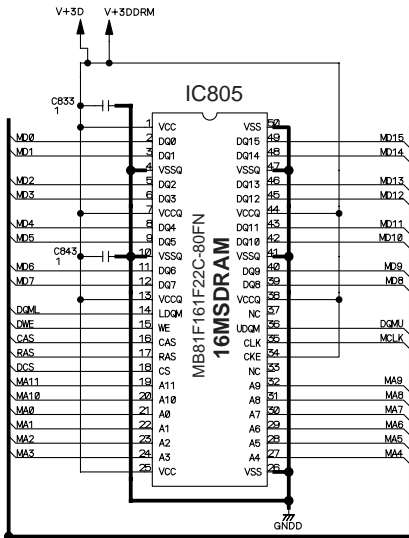

- (V) : RF (VIDEO) SIGNAL ROUTE
- (VD) : VIDEO DATA SIGNAL ROUTE
- (AD) : AUDIO DATASIGNAL ROUTE
- ⏏ : AUDIO SIGNAL ROUTE
- (D) : AUDIO (DIGITAL) SIGNAL ROUTE

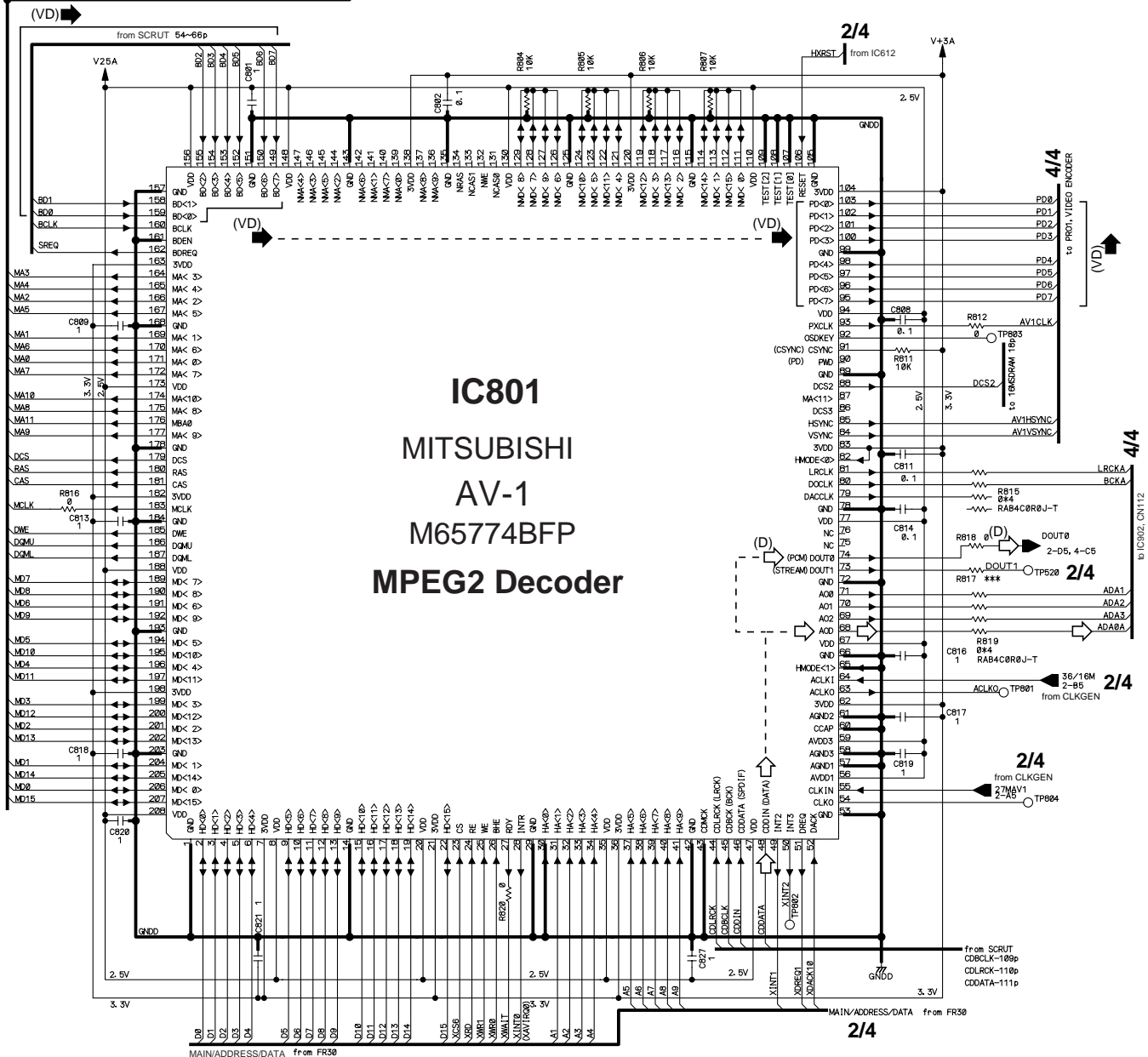
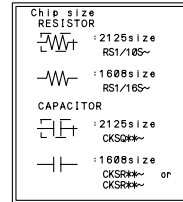

IC801
MITSUBISHI
AV-1
M65774BFP
MPEG2 Decoder

SCHEMATIC DIAGRAMS-7 DVD MAIN BOARD: DB-VPB314/XJ / DB-VPB313/XJ (4/4)

A

B

C

D

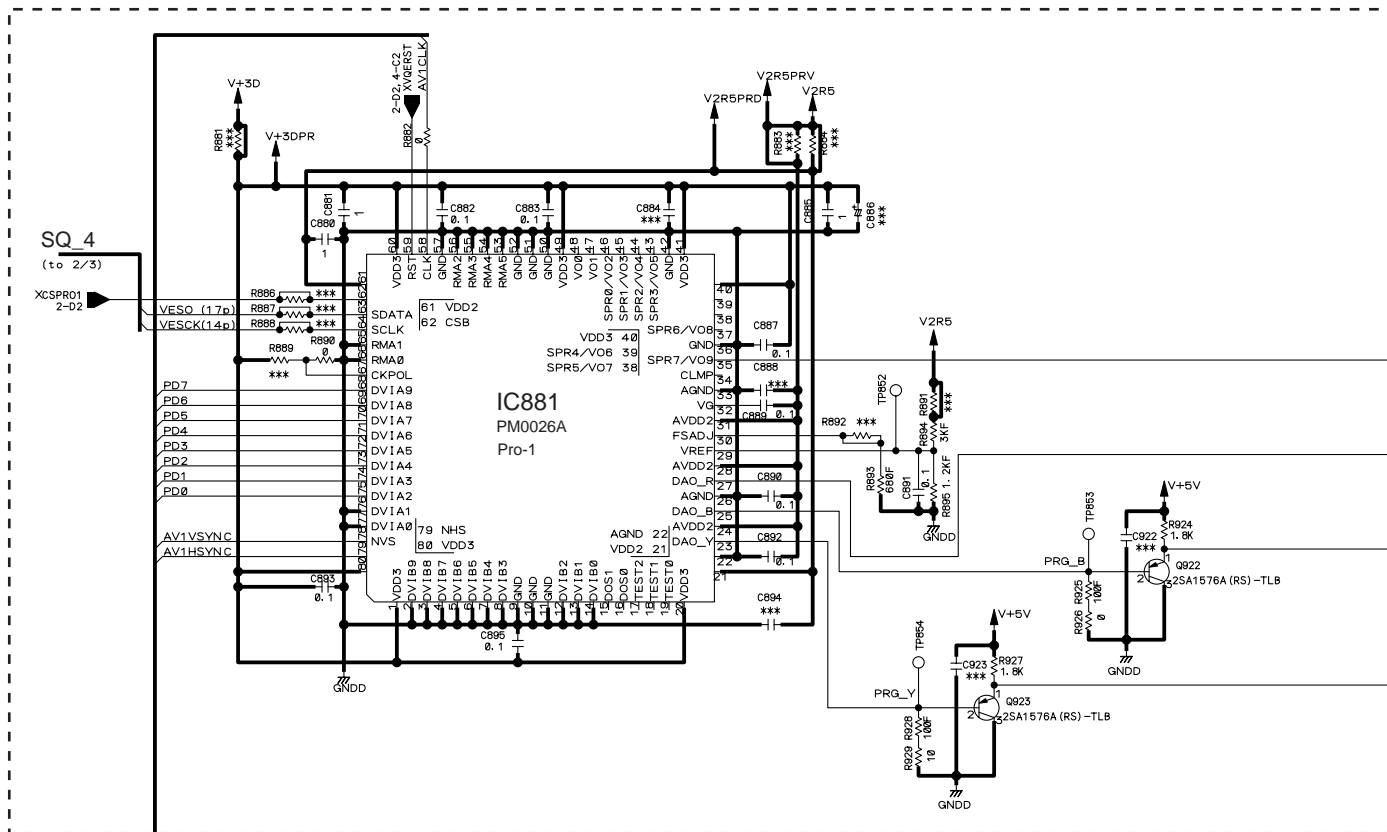

3/4

2/4

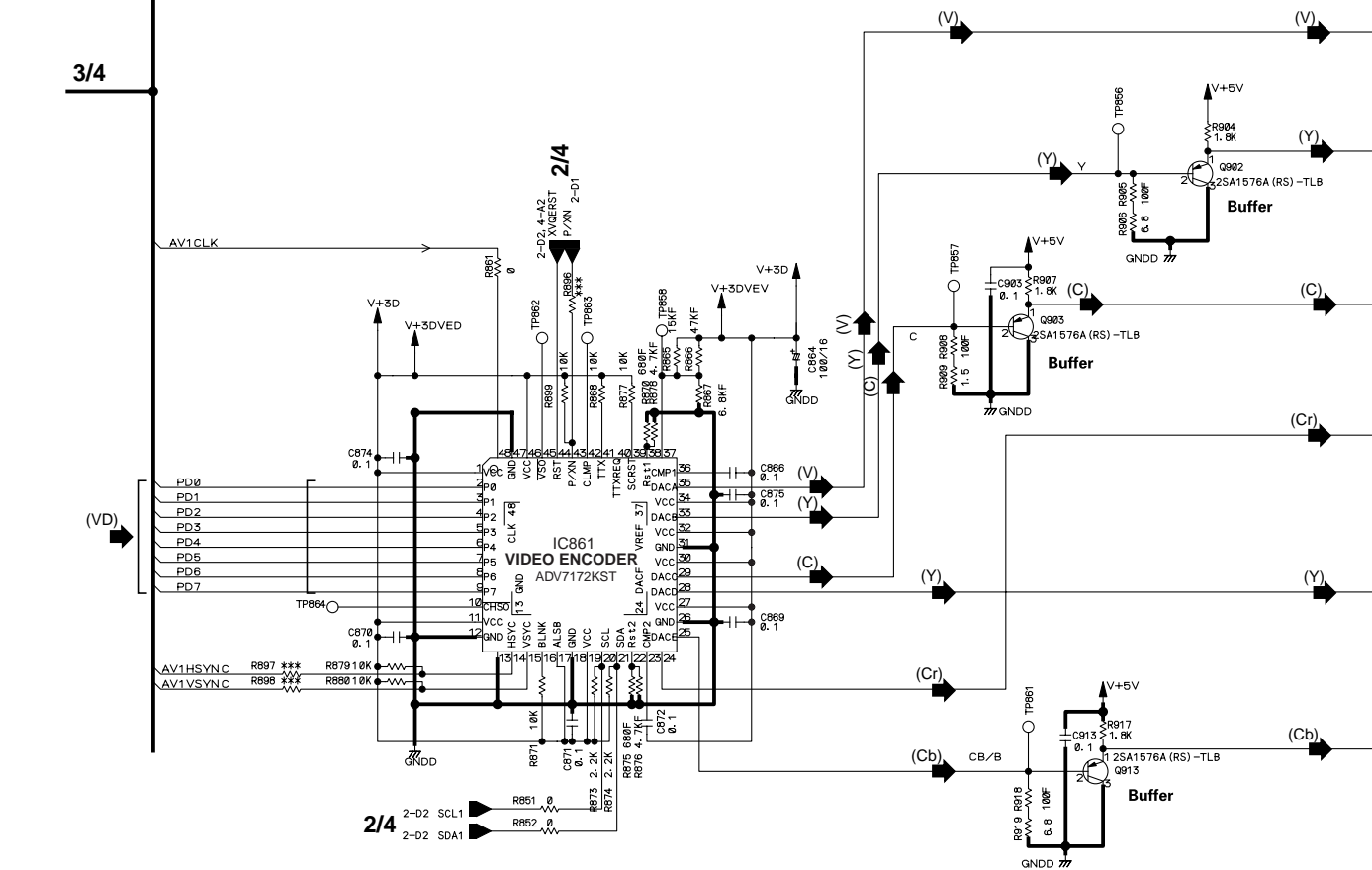

VDB-VPB313/XJ Only

- (VD) : VIDEO DATASIGNAL ROUTE
- (V) : V SIGNAL ROUTE
- (Y) : Y SIGNAL ROUTE
- (C) : C SIGNAL ROUTE
- (Cr) : Cr SIGNAL ROUTE
- (Y) : Y SIGNAL ROUTE
- (Cb) : Cb SIGNAL ROUTE
- ⇨ : AUDIO SIGNAL ROUTE

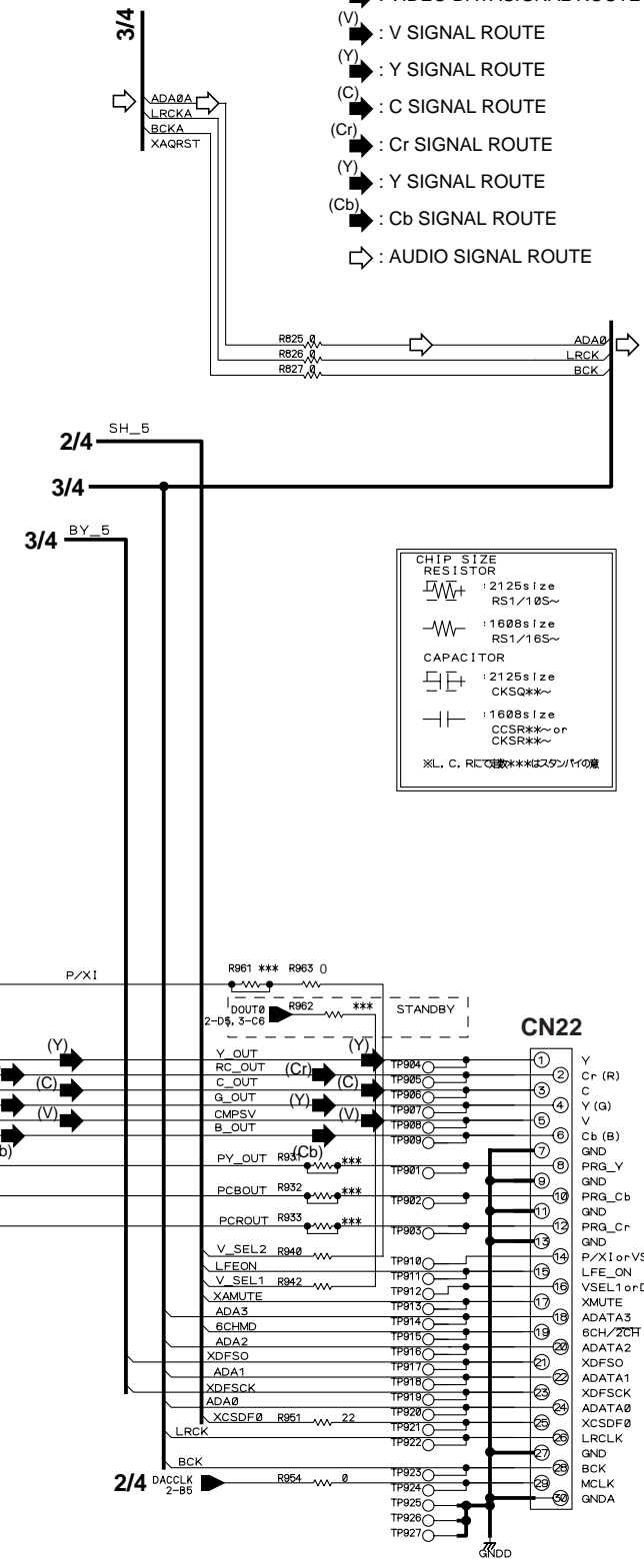
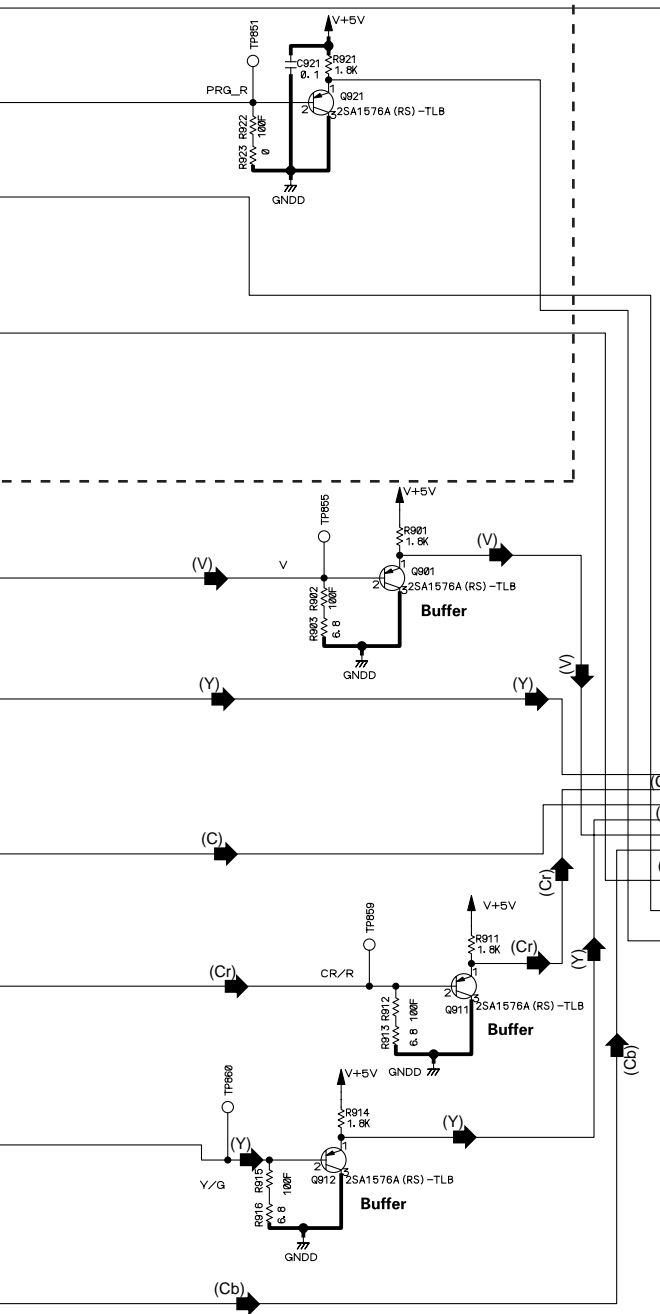

CHIP SIZE RESISTOR

- : 2125 size RS1/10S~
- : 1608 size RS1/16S~

CAPACITOR

- : 2125 size CKSQ**~
- : 1608 size CCSR**~ or CKSR**~

※L, C, R, Cで接合はスタンバイの意

To NAETC-7649 CN22

PC BOARD CONNECTION DIAGRAM

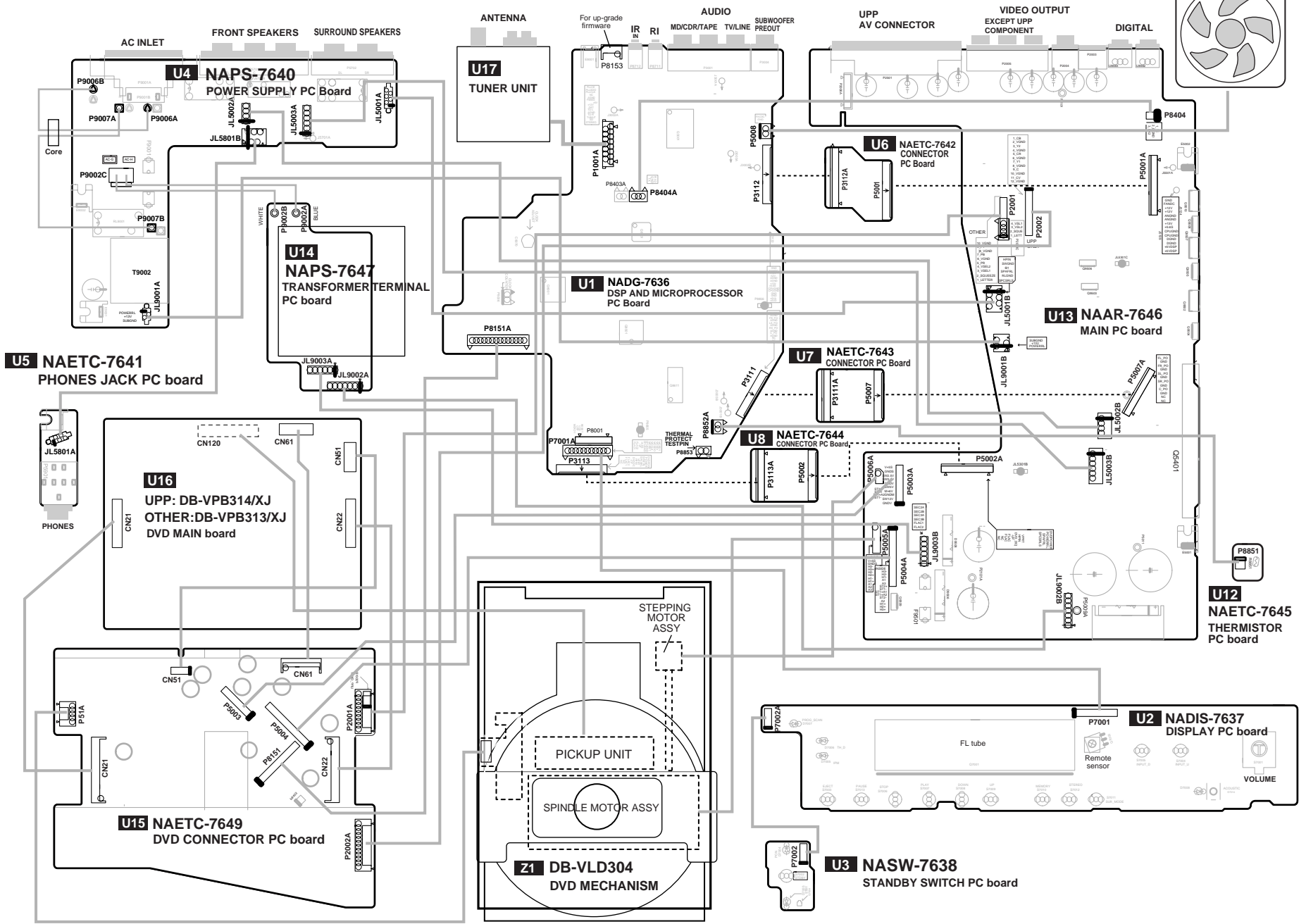



UPGRADE FIRMWARE-1

Prepares for upgrade firmware

REMOTE CONTROLLER
RC-484M
Part No. 24140484

Required to carry out check firmware
version and region cord.

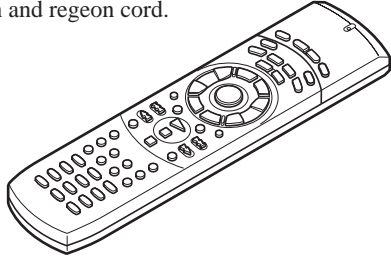

Monitor TV

Required to carry out check firmware
version and region cord.

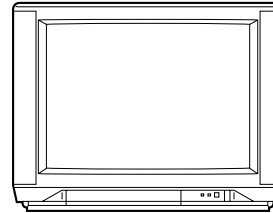

INTERFACE JIG
Part No. GGF1348

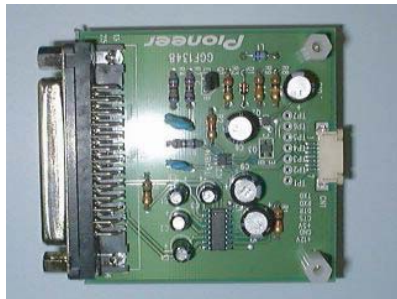

INTERFACE JIG (KIT)
Part No. 0J13

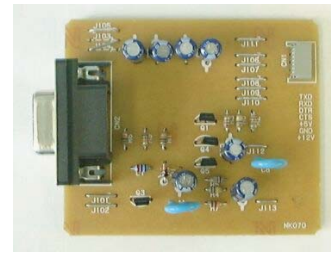

OR

RS-232C Cable (Straight type Cable)

When using GGF1348

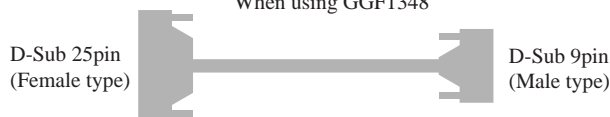

When using 0J13

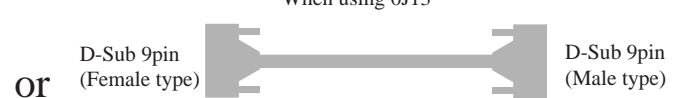

OR



Flexible flat cable
Part No.:GGD1231 or 0F001

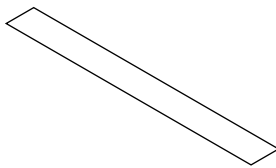

Video cable



PC (Personal computer)

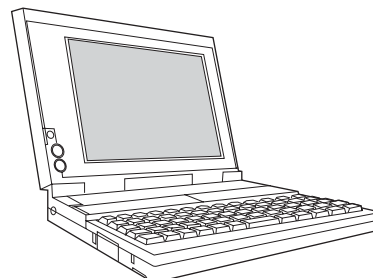

UPGRADE FIRMWARE-2 Connections

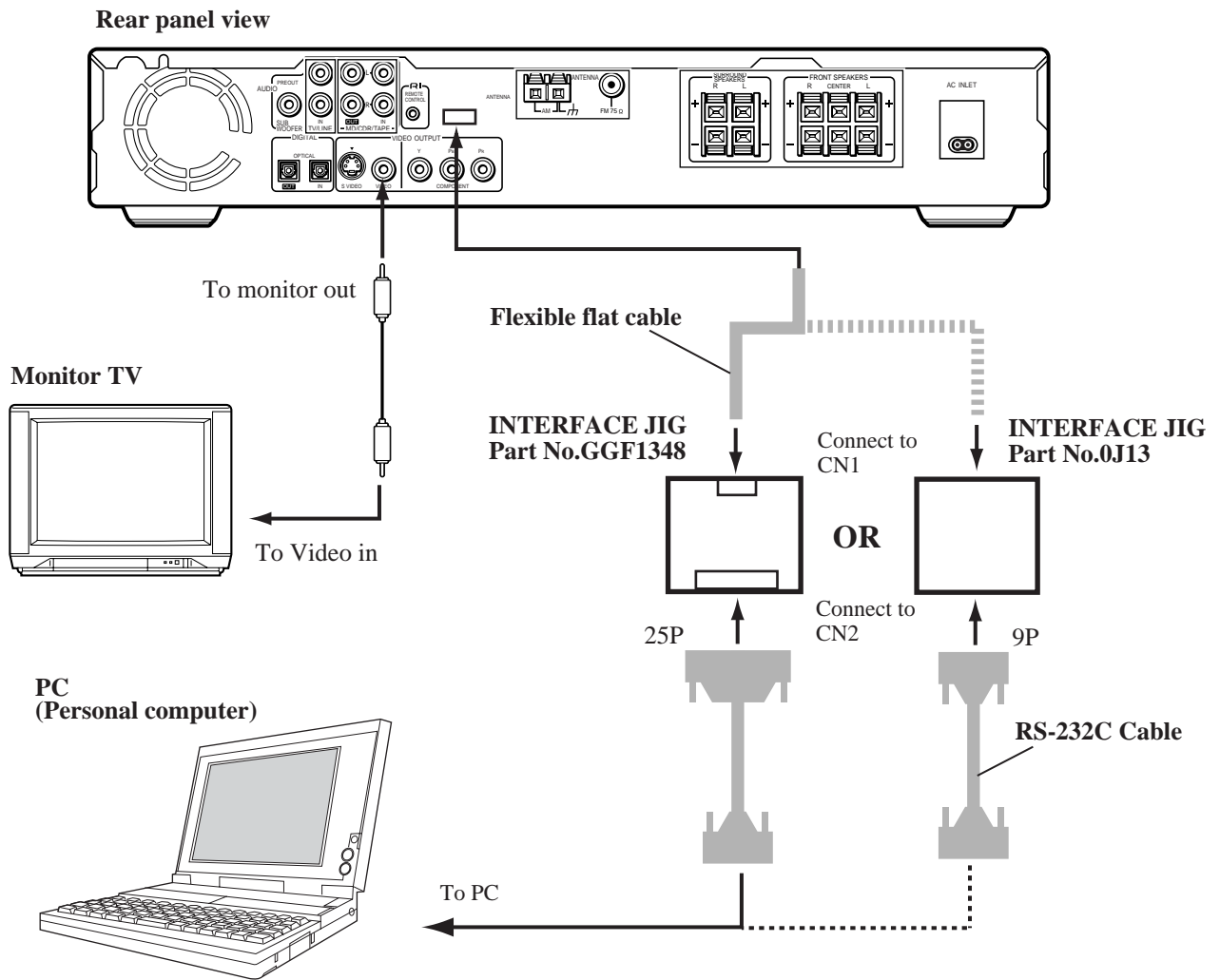

Prepare the file required for rewriting of the firmware.

Build the folder to C drive of the hard disk of PC,
and put in the file required for the folder.

The required file

NOTE: This is one example.

1. **ok_down.exe**
Rewriting tools
2. **down.bat**
Rewriting tools
3. **b1bk1128.sz0**
Firmware program
The file name changes with versions of the firmware.

Explorer view of PC

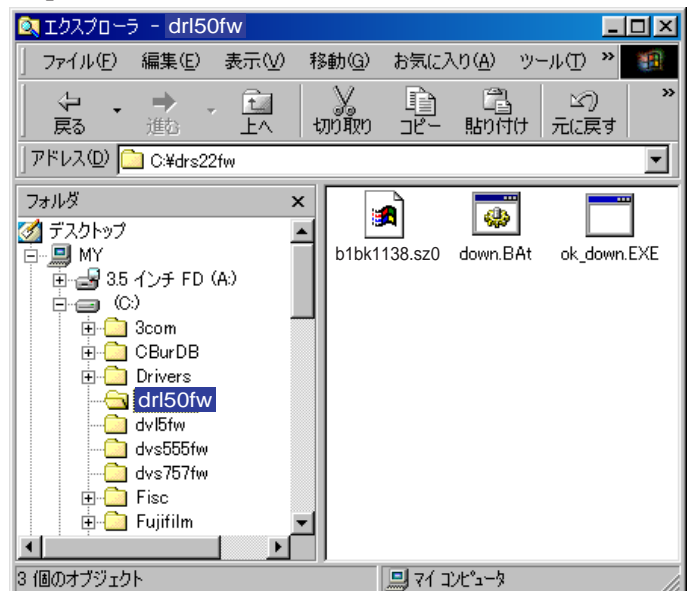

UPGRADE FIRMWARE-3

Flow chart

In the case of upgrade firmware

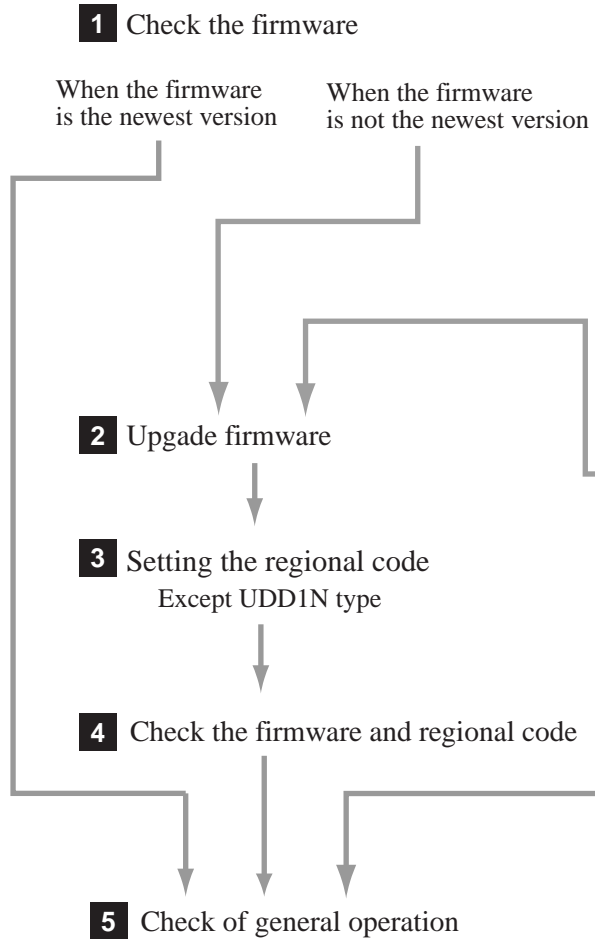

In the case of replace of the DVD main board

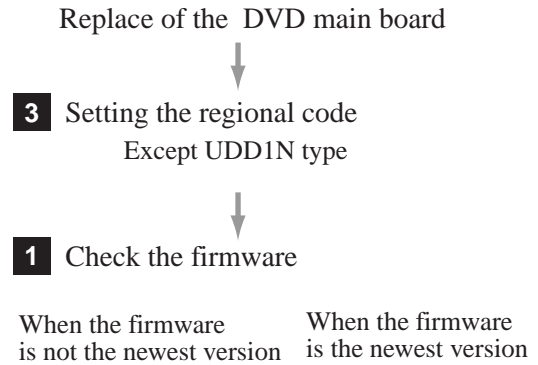

UPGRADE FIRMWARE-4

1 Check the firmware

Please operate it by remote controller (RC-484M).

1. Press the **DVD**.
2. Power ON the unit by press **ON**.
3. Press the **PLAY**.
4. Press **SETUP**.
5. Operate cursor button and select **General** menu.
Refer to (A)
6. Operate cursor button and select **Setup Menu mode**.
Refer to (B)
7. Operate cursor button and set as the state of **Basic**.
Refer to (C)
8. Press **DISPLAY**.
9. Check the Region cord and the firmware version.
Refer to (D) (E)
10. Press the **DISPLAY**.

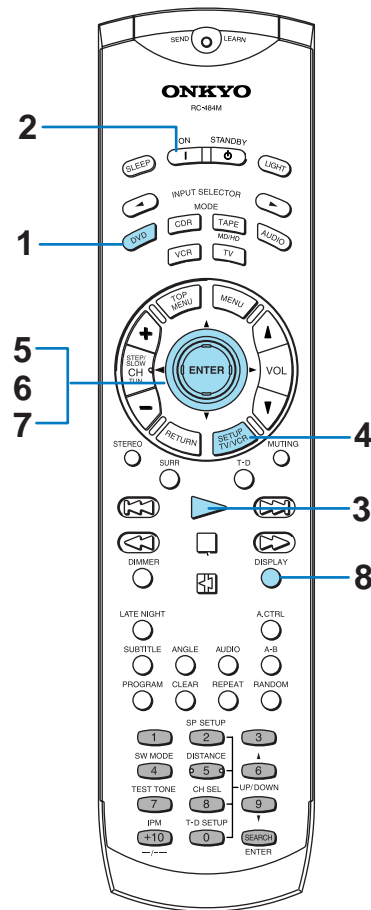

TV monitor

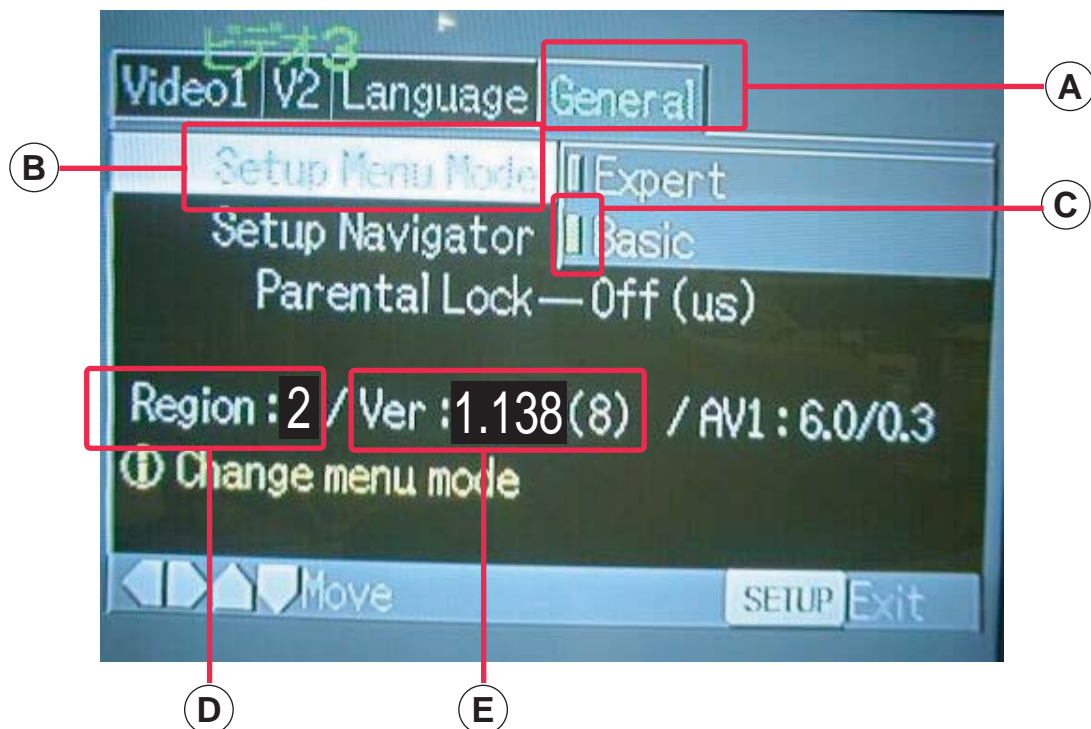

UPGRADE FIRMWARE-6

Download procedures

5. Check that the connection of PC with Unit.
7. Turn ON the power supply switch of the unit.
6. Check that unit is in the state of NO DISC.
8. Press the **Enter** key of PC.
9. Press the **Enter** button, after inputting **MO** by the keyboard of PC.

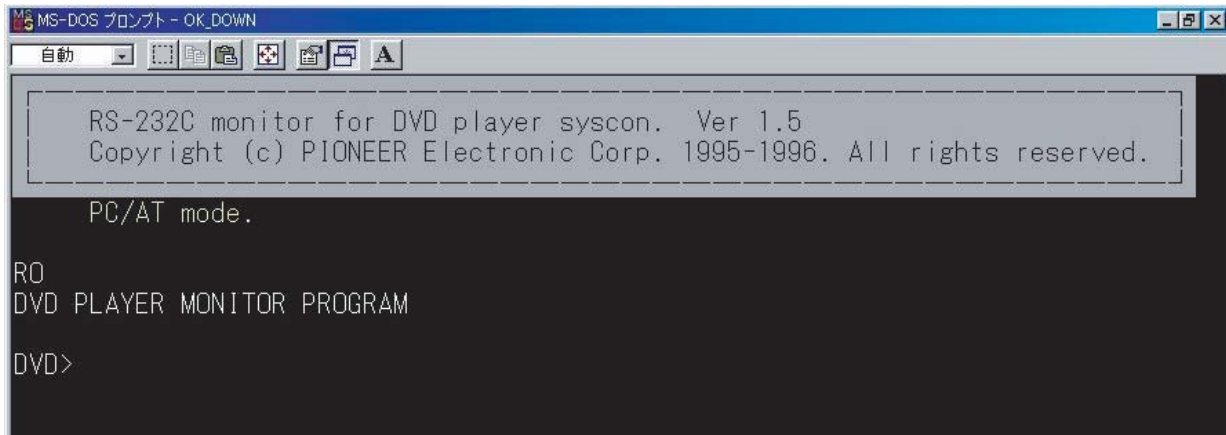

```

MS-DOS プロンプト - OK_DOWN
自動
-----
RS-232C monitor for DVD player syscon. Ver 1.5
Copyright (c) PIONEER Electronic Corp. 1995-1996. All rights reserved.
-----
PC/AT mode.

RO
DVD PLAYER MONITOR PROGRAM

DVD>
  
```

10. Press **ENTER** button, after inputting **SZL** by the keyboard of PC.

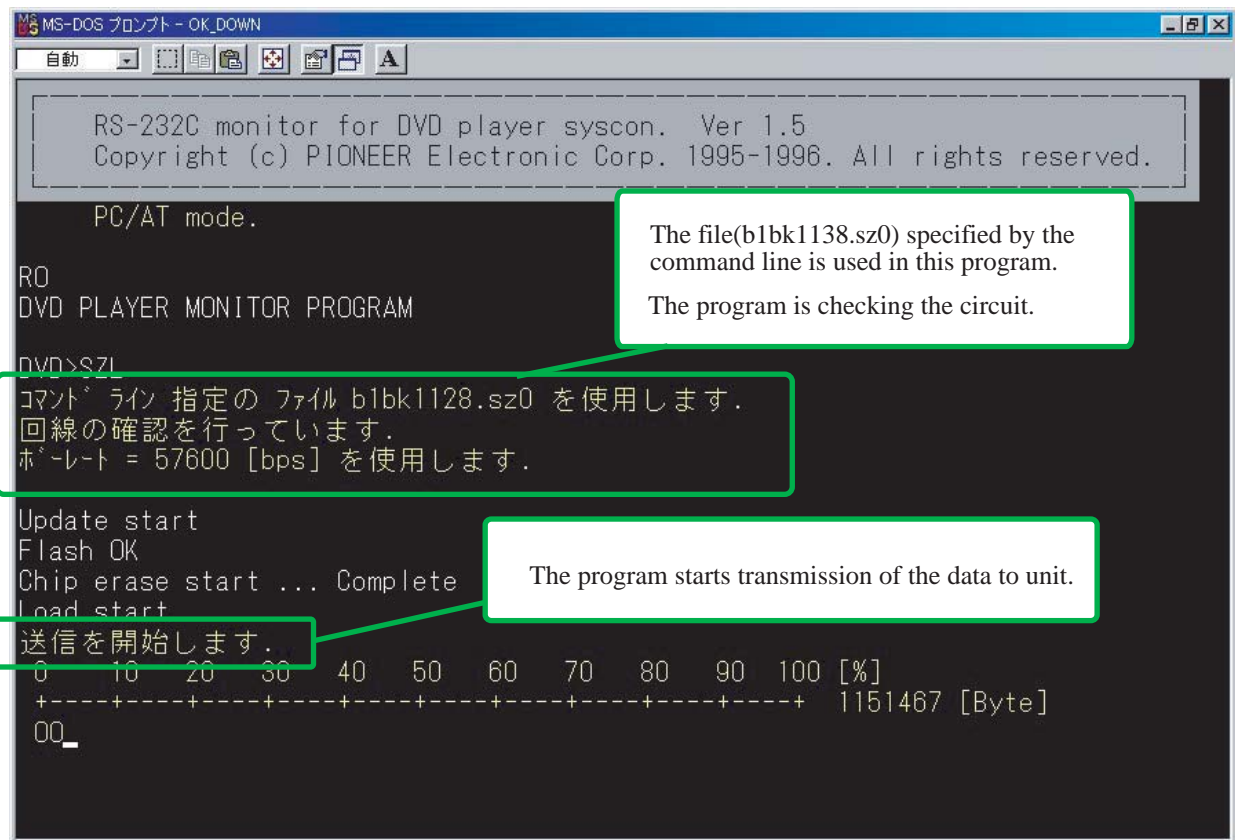

```

MS-DOS プロンプト - OK_DOWN
自動
-----
RS-232C monitor for DVD player syscon. Ver 1.5
Copyright (c) PIONEER Electronic Corp. 1995-1996. All rights reserved.
-----
PC/AT mode.

RO
DVD PLAYER MONITOR PROGRAM

DVD>SZL
コマンドライン指定のファイル b1bk1128.sz0 を使用します。
回線の確認を行っています。
ポート = 57600 [bps] を使用します。

Update start
Flash OK
Chip erase start ... Complete
Load start
送信を開始します。
0 10 20 30 40 50 60 70 80 90 100 [%]
+-----+ 1151467 [Byte]
00_
  
```

The file(b1bk1138.sz0) specified by the command line is used in this program.
The program is checking the circuit.

The program starts transmission of the data to unit.

FL Display

ROM ERASE



LOADING

UPGRADE FIRMWARE-8

3 Setting the regional code

Except UDD1N type.

FL display

REGION INI

TV Monitor

[player's Region setting]
 <1> : Region 1
 <2> : Region 2
 <3> : Region 3
 <4> : Region 4
 <5> : Region 5
 <6> : Region 6

Pick out any one of these!

Operate it using remote controller (RC-484M).

1. Press hold down the **DVD**, then press **2(SP SETUP)**.
2. Press the **number** button which suits each destination.

Correspondence table

Destination	Operation button name	Region code
MDD1N	Region cord is set automatically.	1
MPP2P	2	2
UPT3P	3	3
UDT3P	3	3
UGK3P	3	3
UPA4P	4	4
UDS4P	4	4
UGR6P	6	6

FL display

NO DISC

3. Turn OFF the unit by **STANDBY**.
4. Disconnect the unit and the PC.

4 Check firmware and regional cord

You check whether it is set up firmware and regional cord correctly.

Refer to **1** about check procedure.

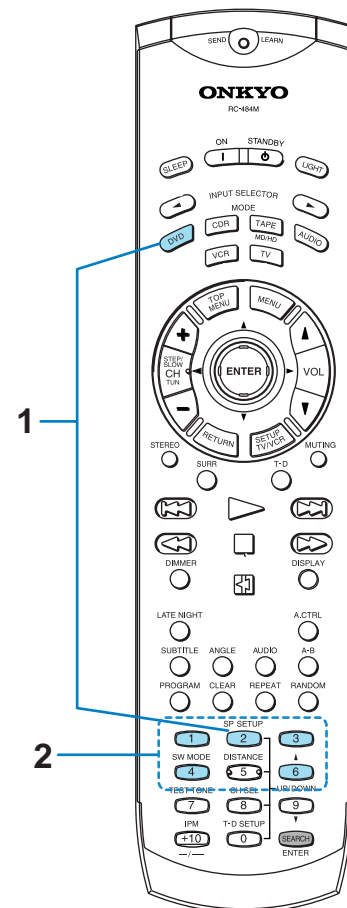

PACKING VIEW

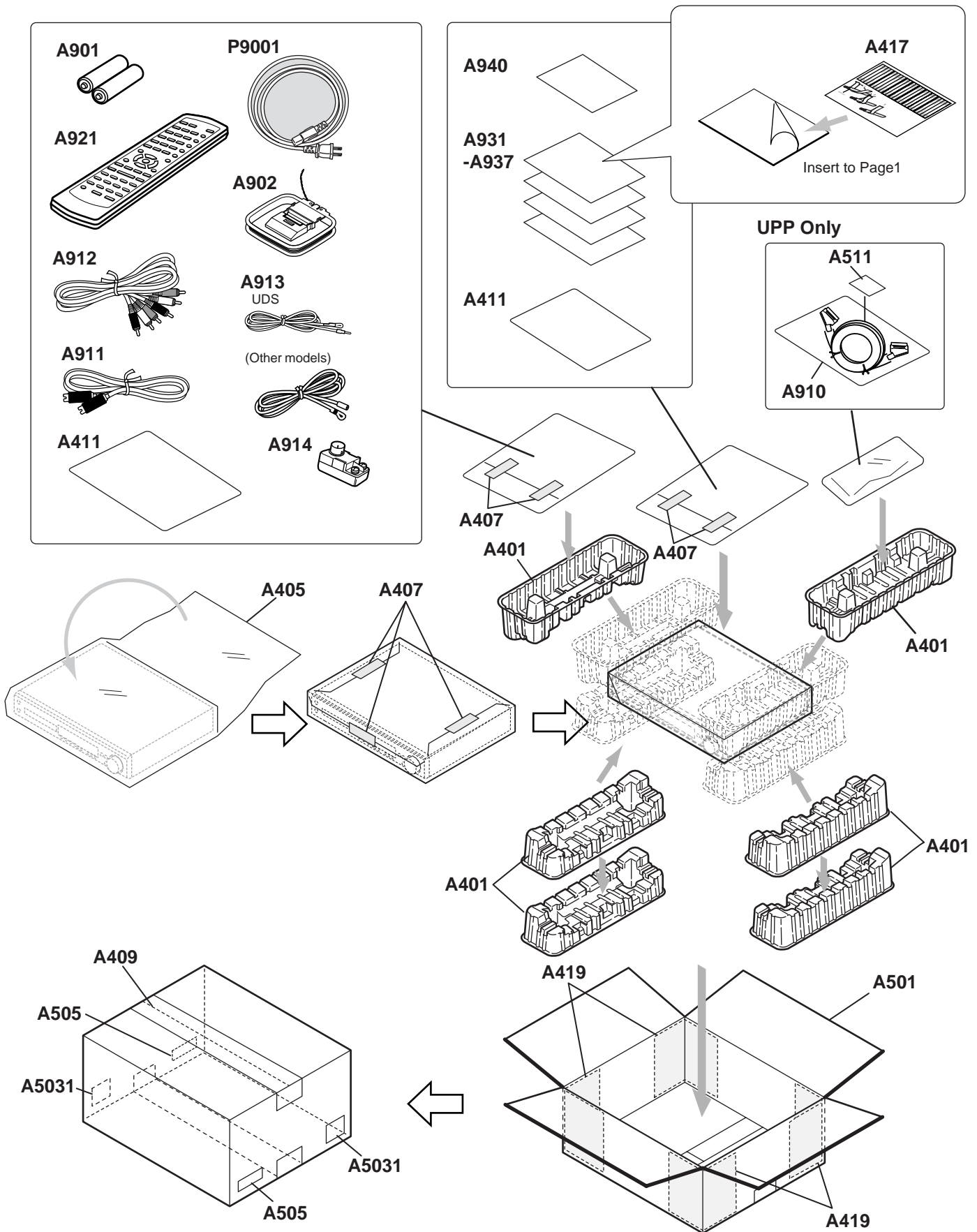

ONKYO CORPORATION

Sales & Product Planning Div. : 2-1, Nisshin-cho, Neyagawa-shi, OSAKA 572-8540, JAPAN
Tel: 072-831-8111 Fax: 072-833-5222

ONKYO U.S.A. CORPORATION

18 Park Way, Upper Saddle River, N.J. 07458, U.S.A.
Tel: 201-785-2600 Fax: 201-785-2650 E-mail: onkyo@onkyousa.com

ONKYO EUROPE ELECTRONICS GmbH

Industriestrasse 20, 82110 Germering, GERMANY
Tel: 089-849-320 Fax: 089-849-3265 E-mail: info@onkyo.de

ONKYO CHINA LIMITED

Units 2102-2107, Metroplaza Tower I, 223 Hing Fong Road, Kwai Chung,
N.T., HONG KONG Tel: 852-2429-3118 Fax: 852-2428-9039