

# ONKYO SERVICE MANUAL

## DIGITAL AUDIO TAPE DECK

### MODEL DT-9000

#### SPECIFICATIONS

##### Signal Format

Tape Recording System:	Rotating head system DAT
Sampling Frequencies:	Recording: 48kHz, 44.1kHz, 32kHz (automatic digital input switching) Playback: 48kHz, 44.1kHz, 32kHz (automatic switching)
Number of Quantization Bits:	16-bit linear
Number of channels:	2-channel (stereo)

##### Audio (Analog recording and playback)

Frequency Response:	2Hz – 22,000Hz
Dynamic Range:	90dB or more
S/N Ratio:	90dB or more
Total Harmonic Distortion:	0.008% or lower
Wow & Flutter:	Unmeasurable

##### Input/Output jacks

Analog Input jacks	
Lowest Input Level:	140mV
Input Impedance:	47k ohms
Analog Output jacks	
Full-Scale Output Level:	2V
Output Impedance:	600 ohms
Headphone Output:	Max. 25mW + 25mW/32 ohms (most suitable impedance is 8 to 600 ohms)
Digital Input Jacks:	Coaxial/75 ohms, Optical (switch equipped)
Digital Output:	Coaxial/75 ohms, Optical (parallel output)

##### Mechanism

Head:	Amorphous/ferrite composite
Cylinder Diameter:	30mm, 1-3/16"
Cylinder Rotational Speed:	2000 r.p.m. (during recording and playback)
Tape Speed:	8.15mm (5/16") /sec., 12.225mm (1/2") /sec. (automatic switching)
Search Speed:	Max. 400 times normal
High-Speed Rewind Time:	About 27 seconds (120 minute tape)

##### General

Power:	AC 120V, 60Hz
Power Consumption:	27W
External Dimensions:	435 (W) x 122 (H) x 339 (D)mm 17-1/8" x 4-13/16" x 13-3/8"
Weight:	5.7kg, 12.6 lbs.

Specifications and external appearance are subject to change without notice because of product improvements.

1 2 3 4 5 6 7 8 9

**EXPLODED VIEWS**

• Cabinet and chassis parts

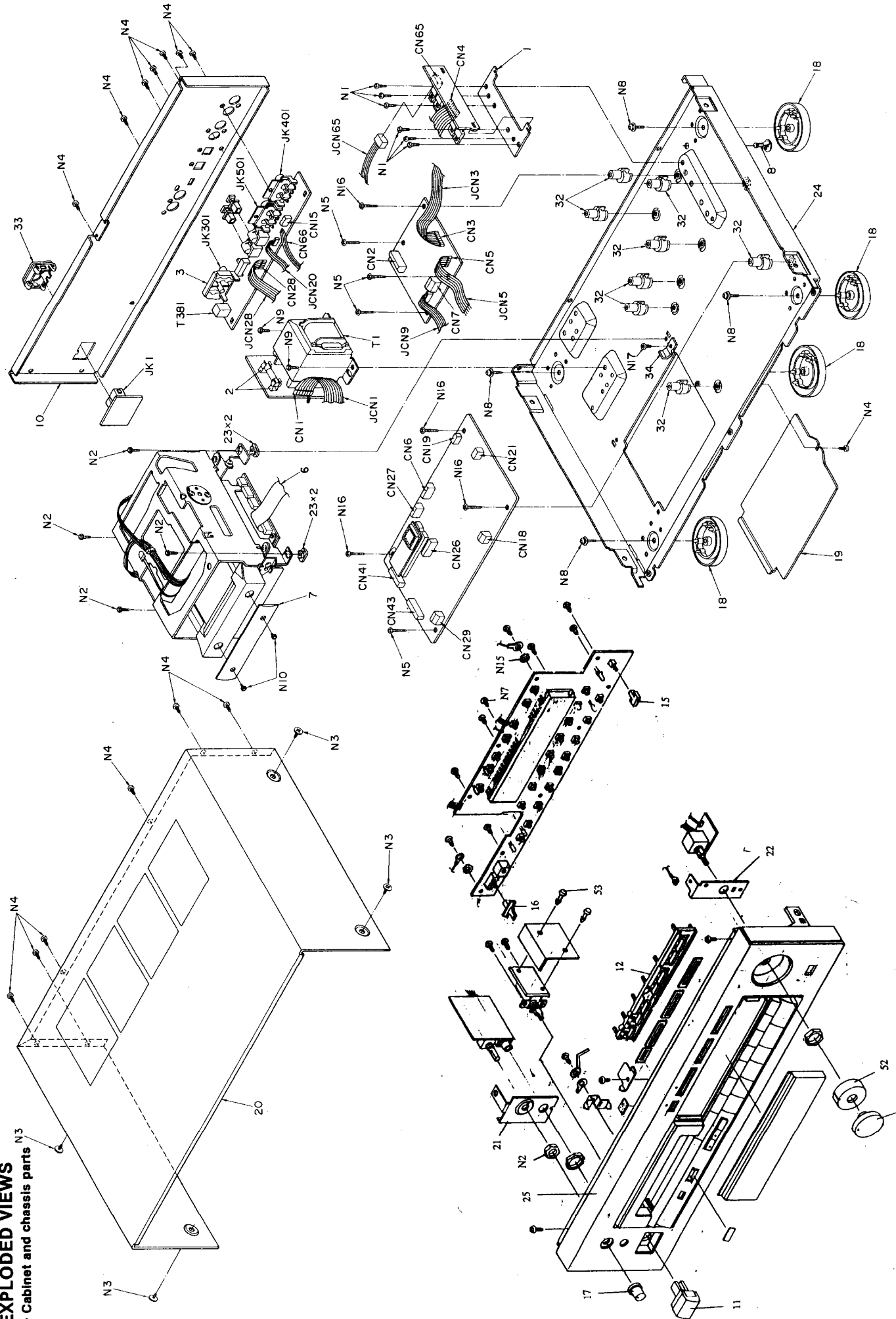

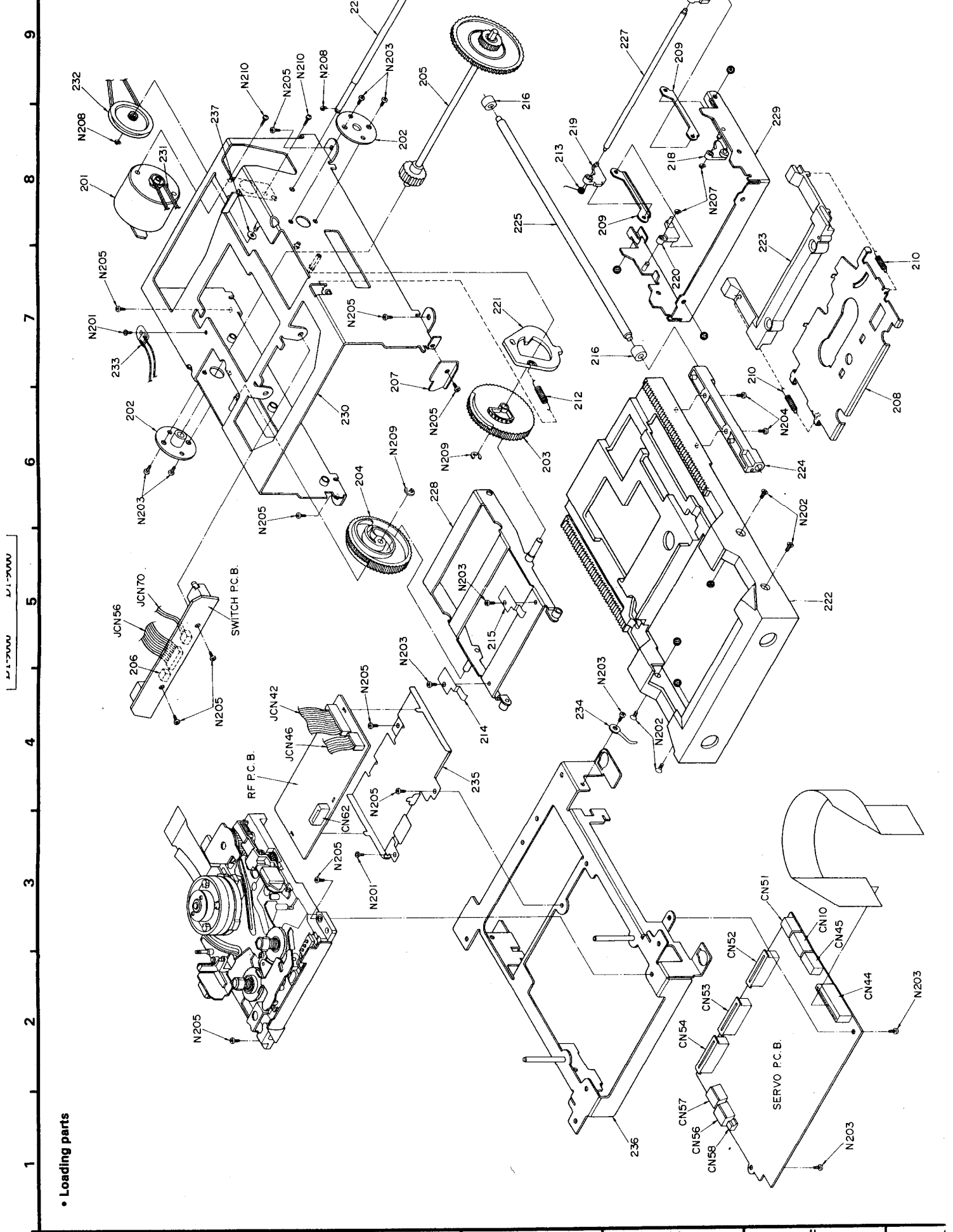

• Loading parts

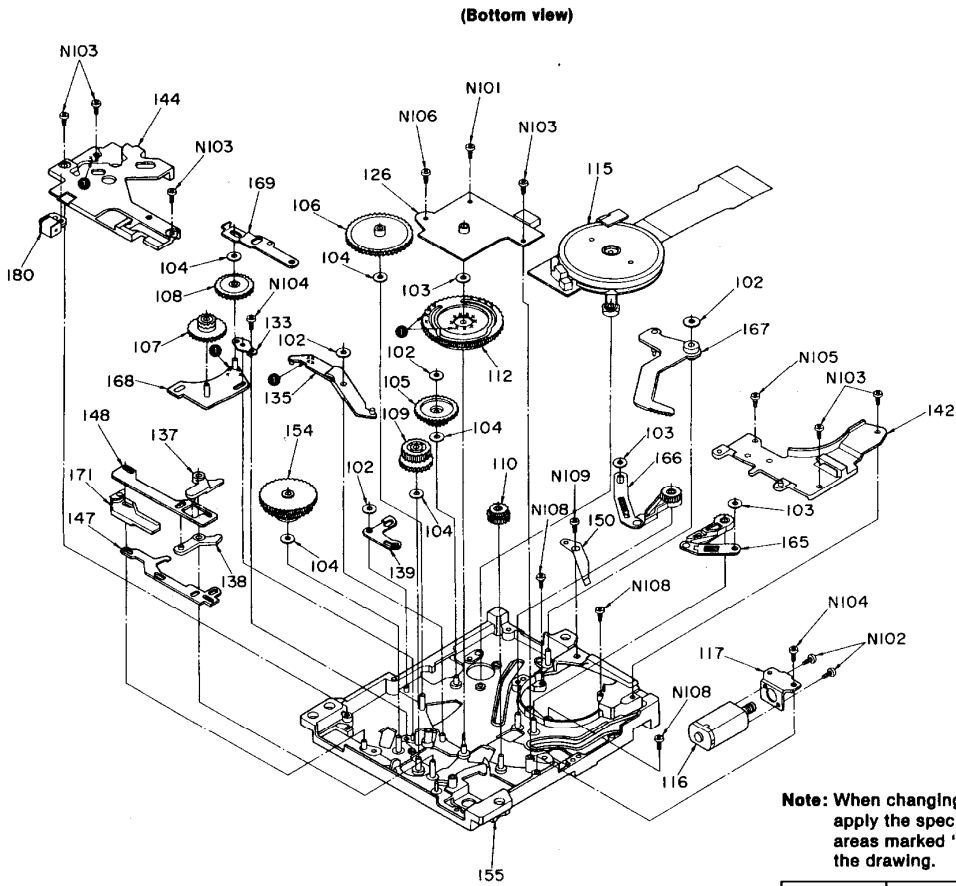
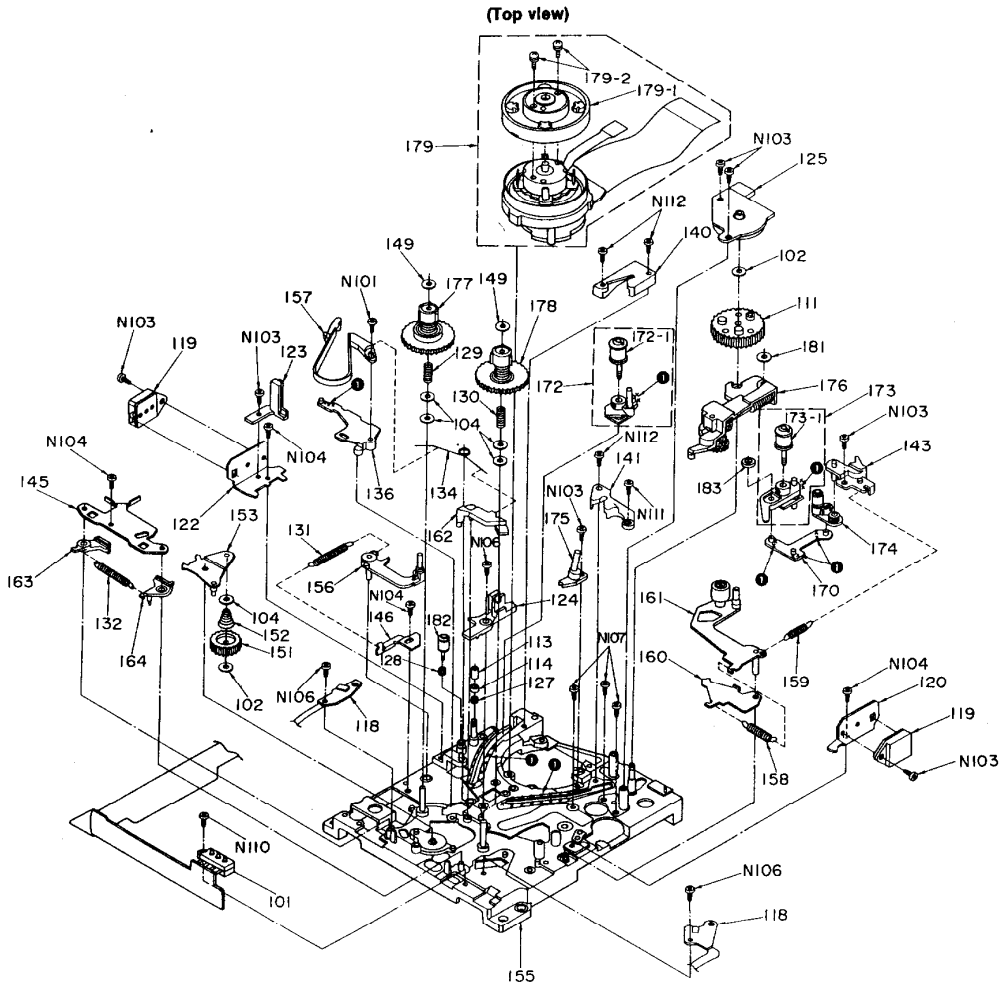

**Note:** When changing mechanism parts, apply the specified grease to the areas marked "x x" as shown in the drawing.

Ref. No.	Part No.
●	RZZ0L05

REF.NO.	PART NO.	DESCRIPTION	REF.NO.	PART NO.	DESCRIPTION
101	24714009	Cassette switch	157	24715036	Tension band ass'y
102	24715013	Washer	158	24710035	Pin pressure spring
103	24175014	Washer	159	24710036	Pinch roller spring
104	24175015	Washer	160	24704011	Pin pressure spring
105	24708008	Main gear A	161	24715037	Pinch arm ass'y
106	24708009	Main gear B	162	24715038	BT lever ass'y
107	24708010	Idler gear P	163	24715039	Supply brake ass'y
108	24708011	Idler gear F	164	24715040	Takeup brake ass'y
109	24708012	Counter gear	165	24715041	Supply load arm
110	24708013	Mode repeating gear	166	24715042	Takeup load arm
111	24708014	Load cam	167	24715043	Load lever
112	24708015	Mode cam	168	24715044	P.F.idler ass'y
113	24706010	Fixed post	169	24715045	Lever,P.F. selection
114	24706011	Fixed post flange	170	24715046	Guide link ass'y
115	24702011	Capstan unit	171	24715047	Plunger link ass'y
116	24702012	Mode motor ass'y(M701)	172	24715048	Supply post roller ass'y
117	24715016	Holder,mode motor	173	24715049	Takeup post roller ass'y
118	24714010	Interface p.c.b.	174	24715050	Takeup guide roller
119	24714011	Begin/End detector sensor ass'y	175	24715051	Takeup inclind base ass'y
120	24715017	Begin detector bracket	176	24715052	Load holder ass'y
122	24715018	End detector bracket	177	24715053	Supply reel ass'y
123	24715019	Lead opener	178	24715054	Takeup reel ass'y
124	24714012	Begin/End detector LED ass'y	179	24701006	Cylinder unit
125	24714013	Load switch ass'y	180	24714015	Plunger
126	24714014	Mode switch ass'y	N101	24710037	Screw
127	24710027	Spring, fixed post	N102	24710038	Screw
128	24710028	Spring, guide roller	N103	24710039	Screw
129	24710029	Spring, supply reel	N104	24710040	Screw
130	24710030	Spring, take-up reel	N105	24710041	Screw
131	24710031	Spring, tension	N106	24710042	Screw
132	24710032	Spring, brake	N107	24710043	Screw
133	24715020	Bracket	N108	24710044	Screw
134	24710033	Spring BT	N109	24710045	Screw
135	24704006	Lever, pinch			<Loading parts>
136	24704007	Lever, tension	201	24702013	Tray motor ass'y
137	24704008	Lever, supply brake	202	27301404	Holder, gear shaft
138	24704009	Lever, takeup brake	203	27301405	Main gear
139	24704010	Lever, load selector	204	27301406	Main gear
140	24715021	Supply stopper	205	27301407	Gear shaft ass'y
141	24715022	Takeup stopper	206	2009990167	Connector(CN72)
142	24715023	Load guide holder	207	27141460	Shaft frame
143	24715024	Guide arm stopper	208	27141461	Bracket, cassette holder
144	24715025	Mode guide plate	209	27141462	Holder arm
145	24715026	Idler guide	210	27180468	Spring
146	24715027	Tension spring hook	211	27180469	Spring
147	24715028	Supply brake drive plate	212	27180470	Spring
148	24175029	Tension brake drive plate	213	27180471	Spring
149	24175030	Washer	214	27180472	Bracket
150	24705031	Ground bracket	215	27180473	Bracket
151	24708016	Idler gear	216	28141085	Rubber
152	24710034	Idler spring	217	27301408	Holder, shaft
153	24715032	Idler arm ass'y	218	27301409	Holder
154	24715033	Drive gear	219	27301410	Holder, shaft
155	24715034	Chassis unit	220	27301411	Holder
156	24715035	Tension arm ass'y	221	27301412	Holder, main gear

REF.NO.	PART NO.	DESCRIPTION
222	27301413	Tray
223	27301414	Cassette holder
224	27301415	Shaft bracket
225	27260303	Shaft
226	27260304	Shaft
227	27260305	Shaft
228	27141463	Sub frame
229	27141464	Cassette holder
230	27141465	Frame
231	27301417	Belt
232	27301416	Pulley gear
233	4000125	DEW sensor
234	27255008	Ground terminal
235	27141466	Shield plate
236	27141467	Mechanism frame
S751,S752	25065433	Open/Close switch
N201	82142003	2P+3F(BC),Pan head screw
N202	801462	Screw
N203	838430088	3TTB+8B(BC),Screw
N204	801463	Screw
N205	8213010	3P+10FN(BC),Screw
N206	838430068	3TTB+6B(BC),Screw
N207	8930151S	ES-1.5S,Washer
N208	8930201S	ES-2S,Washer
N209	8930301S	ES-3S,Washer
N210	801464	Screw

REF.NO.	PART NO.	DESCRIPTION	PART NAME	REF.NO.	PART NO.	DESCRIPTION	PART NAME
U1	24505286	DG-AS-1	Main pc board ass'y	21	27141458	(HP)	Bracket
U2	24505287	DG-AS-2	Input/output terminal pc board ass'y	22	27141457	(REC)	Bracket
U3	24505288	SS-AS-1	Servo pc board ass'y	23	24506972		Floating rubber
U4	24505291	RF-AS-1	RF pc board ass'y	24	27171439		Bottom panel
U5	24505294	DIS-AS-1	Operation pc board ass'y	25	27211294		Front panel ass'y
U6	24505292	AF-AS-1	Headphne terminal pc board ass'y	32	27190823	(PCB)	Holder
U7	24505293	AF-AS-2	Rec. level pc board ass'y	33	27190824	(Socket)	Holder
U8	24505295	PS-AS-1	Power supply (1) pc board ass'y	51	28324265		Rec.level knob L
U9	24505296	PS-AS-2	Power supply (2) pc board ass'y	52	28324266		Rec. level knob R
U10	24505301	PS-AS-3	Power transformer pc board ass'y	N1	838430088	3TTB+8B(BC)	Self-tapping screw
U11	24505298	PS-AS-4	Power switch pc board ass'y	N2	801454		Special screw
U12	24505299	PS-AS-5	AC-IN terminal pc board ass'y	N3	801455		Special screw
U13	24505300	ETC-AS-1	RI terminal pc board ass'y	N4	801230	3STS+8BQ(BC)	Self-tapping screw
1	27160275		Radiator	N5	838130168	3TTB+16B	Self-tapping screw
3	27301401		Ground plate	N6	831430100	3TTB+10P(BC)	Self-tapping screw
	27141454	(FL)	bracket	N7	838130080	3TTB+8P	Self-tapping screw
7	27211293		Door	N8	834430068	3TTS+6B(BC)	Self-tapping screw
10	27121415		Back panel	N9	831430088	3TTW+8B(BC)	Self-tapping screw
11	28323987-1		Power knob	N10	801456		Special screw
12	28324261		Slide knob	N11	801459		Special nut
15	28324262		Input knob	N12	801460		Special nut
16	28324263		Timer knob	N14	801461		Special nut
17	28324264		Headphone knob	N15	87313006	M-3B	Washer
18	27175259		Leg	N16	801458		Special screw
19	27141456	(Bottom panel)	Bracket	N17	801457		Special screw
20	28184477		Top cover				

#### PACKING MATERIALS AND ACCESSARY

PART NO.	DESCRIPTION
29052186	Master carton box
29091450	Pad F
29091451	Pad B
29100118	Protection sheet
29341530	Instruction manual
29365019	Warranty card
29358002G	Service station list
2010231	Power supply cord
3010180	Two batteries
2010200	RC cord
2010166	Connection cord

# PRINTED CIRCUIT BOARD-PARTS LIST

CIRCUIT NO.	PART NO.	DESCRIPTION	CIRCUIT NO.	PART NO.	DESCRIPTION
	ICs			Transistors	
IC11	222780120	7812	Q272	2214090R1	DTA123JK
IC12	222780050	7805	Q274	2214044R0	2SB709-R
IC13	222790205	79M20	Q275	2214070R1	DTC124EK
IC14	222790203	79L20	Q301,Q351	2213940R0	XN1212
IC15	222780125MIT	78M12L	Q311-Q313	2213973	2SC3315-C
IC16	222790125MIT	79M12L	Q314,Q315	2213950R0	XN1112
IC101	22240451R0	AN7030S	Q352	2213981	2SA1309-S
IC102	22240452R0	AN7035SC	Q353	2213994	2SC1047-D
IC201	22240441R0	MN6742SDR	Q401	2213960	UN4124
IC202	22240442R0	MN53020SDQ	Q402	2213940R0	XN1212
IC203	22240443R0	AN8320NFA	Q501	226036	UN4112
IC204,IC205	22240444	AN3841SR	Q502,Q508	2213950R0	XN1112
IC206	22240450	M5228FP	Q503,Q504	2213973	2SC3315-C
IC207,IC360	222740045R0MA	74HC04	Q505,Q506	2201893,	2SC3311-Q,
IC208	22240445R0MA	MN74HC4066	Q511	2201894 or	2SC3311-R or
IC209	222780053R0MA	78L05		22018935	2SC3311-S
IC271	22240446R0	MN17541SDN	Q507	2213960	UN4124
IC272	22240447R0	AN6607NS	Q509,Q510	2213973	2SC3315-C
IC273	22240448R0	AN1339S	Q512	2201903,	2SA1309-Q,
IC274	22240239	TA7291S		2213982 or	2SA1309-R or
IC275	22240449R0	TC4S81FTX		2213983	2SA1309-S
IC301	22240432	MN188161SDS4	Q551-Q554	2213814,5,6	2SD1450-R,S,T
IC302	22240433	MN1281R-TA	Q601-Q605	2213510	DTA114ES
IC351	22240423R3	MN6624		Diodes	
IC352	22240437R0	SRM20256LM10	D11-D15	223192	! 1SR35200TB
IC354	222755	74HCU04	D16,D18	22380002	! GP20DLR
IC355	24120027	TORX174	D17,D19	223192	! 1SR35200TB
IC356	24120035	TOTX174	D21	224450511	MTZ5.1A
IC357	222966	M5238L	D201	223199R0	MA701
IC358,IC359	222740005R0MA	74HC00	D203	223200	1N4606
IC361	222740006R0MA	74HC04	D271	223124	1S2473
IC362	222740005R0MA	74HC00	D351	223198	SVC321SPA-A5
IC363	222742535R0MA	74HC253	D381-D384	223163	1SS133
IC401,IC402	222836	M5219L	D401,D507	224990032	MA4033M
IC403	222973	M5220L	D501	223163	1SS133
IC405,IC406	22240438R0	MN6460	D503-D506	223163	1SS133
IC407	22240440	AN78N05	D509,D510	223163	1SS133
IC411	222836	M5219L	D611-D628	223163	1SS133
IC501	22240439R0	MN6470	D630-D637	223163	1SS133
IC511-IC514	222836	M5219L	D642,D643	223163	1SS133
IC515,IC516	222966	M5238L	D702	224990042	MA4056M
IC551,IC552	222652	M5218L	D721,D722	223163	1SS133
IC601	22240422R3	M50754-164FP		L.E.Ds	
IC602	22240455R0	AN6873S	D601-D603	225263	LN28RCPP-JF
IC603	222740045R0MA	74HC04	D605	225264	LN31GPH-JF2
	FL tube		D607,D608	225265	LN29RRH-JF1
FL601	212094	BG849GK		Coils	
	Transistors		L1,L2	231200	! SLQX400-D
Q102-Q105	2214000R0	UN5216	L101	231194R1	ELJFA470KF
Q106,Q107	2214010R0	2SC3937	L104	231193R1	ELJFA180KF
Q109	2214000R0	UN5216	L106	231195R1	ELJFA101KF
Q201	2214024R0	2SB956-R	L108	231197	RLQZB471KTD
Q271	22140350R0	2SD1280-S	L109,L110	231193R1	ELJFA180KF



CIRCUIT NO.	PART NO.	DESCRIPTION	CIRCUIT NO.	PART NO.	DESCRIPTION
	Coils			Elect. capacitors	
L120,L203	231196	RLQZB101KT-D	C419,C420	3500136	ECEA1CPZ101B
L202	231199	RLM9R001-Z	C423,C424	3500136	ECEA1CPZ101B
L351	233400M022	NCH-2225	C431,C432	3500137	ECEA0JPZ221B
L352	231190	NSO-4054	C437,C438	354780479	4.7MF,50V
L381	231198	RLQZB470KT-D	C439-C441	354742209	22MF,16V
	Ferrite beads		C443,C444	354742209	22MF,16V
L382-L384	230909	EXCELDR35V	C451-C454	354722219	220MF,6.3V
L481,L482	230909	EXCELDR35V	C455,C456	3500137	ECEA0JPZ221B
L550-L552	230909	EXCELDR35V	C483,C484	3500135	ECEA1CBZ330B
L571,L572	230909	EXCELDR35V	C485,C486	3500136	ECEA1CPZ101B
	Transformers		C491,C492	3500135	ECEA1CBZ330B
T1	2300653	! NPT-1108D,Power	C501,C503	354724719	470MF,6.3V
T381	232154	NSRF-1055,Pulse	C507,C508	354741019	100MF,16V
	Crystals		C511,C512	3500138	ECEA0JPZ331B
X201	3010178	C8M00J01	C515-C518	3500136	ECEA1CPZ101B
X351	3010174	AF5115CF	C527,C528	350135	ECEA1CBZ330B
X352	3010175	AF6630CE	C537,C538	350135	ECEA1CBZ330B
X353	3010176	AF3817CF	C561,C562	354742209	22MF,16V
X354	3010177	AF3781CH	C563,C564	354741009	10MF,16V
	Ceramic oscillators		C603,C657	355724709	47MF,6.3V
X202,X301	3010154	CST8.00MT	C655,C659	355761009	10MF,35V
X601	3010149	CST6.00MGW		IS capacitor	
	Ceramic capacitors		C1	3500065A	! DE7150FZ103PAC400V/125V
C19	330236829	6800pF,100V		Mylar capacitors	
C604,C605	3300009	ECBT1E103ZF5	C413,C414	3700019	ECHR1H681JZ3
C652,C654	3300010	ECBT1H102KB5	C415,C416	3700020	ECHR1H182JZ3
C656,C702	3300010	ECBT1H102KB5	C417,C418	3700014	ECHR1H101JZ3
C658,C660	3300009	ECBT1E103ZF5	C421,C422	3700014	ECHR1H101JZ3
C694,C703	3300009	ECBT1E103ZF5	C481,C482	3700017	ECHR1H102JZ3
C721,C751	3300009	ECBT1E103ZF5	C521,C522	3700016	ECHR1H331JZ3
C701	3300011	ECBT1H471KB5	C525,C526	3700016	ECHR1H331JZ3
	Elect. capacitors		C529,C530	3700018	ECHR1H392JZ3
C110	355722219	220MF,6.3V	C531,C532	3700021	ECHR1H151JZ3
C129,C130	355722209	22MF,6.3V	C533,C534	3700018	ECHR1H392JZ3
C20,C22	3500141	ECEA1EPZ332E	C535,C536	37000136	ECEA1CPZ101B
C201,C230	355724709	47MF,6.3V	C571,C572	3700017	ECHR1H102JZ3
C21,C23	354741009	10MF,16V		Plastic capacitors	
C212,C213	355742209	22MF,16V	C224	375526834	0.068MF,5%,50V
C229	355722219	220MF,6.3V	C381,C388	375521044	0.1MF,5%,50V
C232	355742209	22MF,16V	C384	375521034	0.01MF,5%,50V
C234	355744709	47MF,16V	C445,C446	375521044	0.1MF,5%,50V
C24	354756829	6800MF,25V	C539,C540	375521034	0.01MF,5%,50V
C25,C27	354741009	10MF,16V	C571,C572	3700017	ECHR1H102JZ3
C26	354744729	4700MF,16V		Metal oxide film resistors	
C270,C602	355724709	47MF,6.3V	R13,R14	441625604	560hm,1W
C28	354782219	220MF,50V	R237,R245	441520334	3.30hm,1/2W
C29	354763309	33MF,35V	R274	441528294	0.820hm,1/2W
C32	354784709	47MF,50V		Semi-fixed resistors	
C357	354723309	33MF,6.3V	VR104,VR105	5225118	EVNDXAA00B53
C367,C368	354723309	33MF,6.3V	VR106	5225117	EVNDXAA00B14
C369	354722219	220MF,6.3V	VR107,VR108	5225116	EVNDXAA00B13
C372,C374	354723309	33MF,6.3V	VR201	5225119	EVNDXAA00B54
C382	354721019	100MF,6.3V	VR271	5221026	EVNDCAA03B54
C411,C412	3500135	ECEA1CBZ330B	VR451,VR452	5225116	EVNDXAA00B13

CIRCUIT NO.	PART NO.	DESCRIPTION	CIRCUIT NO.	PART NO.	DESCRIPTION
	Variable resistors			Sockets	
VR401	5104287	RRV18B01A14A	JCN65	2009990156	REZ0142A
VR551	5104286	EVV57A022A14	JCN8	2009990155	REZ0133A
	Relay		JCN9	2009990162	REZ0121A
RLY501	25065431	AG80239		Stereo headphone jack	
	Push switches		JK550	25045331	SJJD19
S1	25035624	! ESB8249V		Terminals	
S602	25035630	ESB64801	JK301	25045327	SJF3057-7A-1
S611-S621	25035629	EVQQTG05R	JK401,JK501	25045328	SJFD4-1
S622-S628	25035629	EVQQTG05R		AC inlet	
S630-S635	25035629	EVQQTG05R	JK1	25050542	SJS9234B
	Slide switches			Fuseholder	
S381	25065430	ESD1521201	2	250113	SN5051
S601	25065432	ESD1511301		Fuse	
	Plugs		F1	252023	! 0.5A-T
CN10	25055525	NPLG-6P500			
CN15,CN19	25055523	NPLG-4P498			
CN26	25055530	NPLG-8P353			
CN41	25055532	NPLG-10P355			
CN45	25055524	NPLG-5P499			
CN51	25055522	NPLG-3P497			
CN56	25055575	RJP4G28ZA			
CN57	25055576	RJP6G28ZA			
CN58	25055577	RJT036W002			
	Remote control sensor				
RM601	24130003	GP1U50XS			
	RI terminals				
JK701,JK702	25045332	RJJ33T01			
	Sockets				
CN1,CN4	25050547	RHR197ZA			
CN17	25050541	RHR191ZA			
CN18	25050526	NSCT-4P349			
CN2	25050532	NSCT-10P355			
CN21,CN22	25050349	NSCT-6P176			
CN27,CN29	25050527	NSCT-5P350			
CN28	25050545	RHR192ZA			
CN3	25050547	RHR197ZA			
CN43,CN44	25050500	NSCT-17P323			
CN5	25050546	RHR193ZA			
CN52-CN54	25050358	NSCT-15P185			
CN6,CN7	25050528	NSCT-6P351			
CN62	25050354	NSCT-11P181			
CN65	25050543	RHR190ZA			
CN66	25050525	NSCT-3P348			
CN82	25050524	NSCT-2P347			
JCN1	2009990159	REZ0140A			
JCN16	2009990158	REZ0134A			
JCN17	2009990157	REZ0131A			
JCN20	2009990151	REZ0119A			
JCN28	2009990153	REZ0118A			
JCN3	2009990160	REZ0120A			
JCN30	2009990154	REZ0132A			
JCN42	2009990152	REZ0125A			
JCN45	2009990164	REZ0126A			
JCN5	2009990161	REZ0122A			

NOTE: THE COMPONENTS IDENTIFIED BY MARK ! ARE CRITICAL FOR RISK OF FIRE AND ELECTRIC SHOCK. REPLACE ONLY WITH PART NUMBER SPECIFIED.

## ■ MEASUREMENTS AND ADJUSTMENTS

### • PREPARATION

- (1) Remove the cabinet

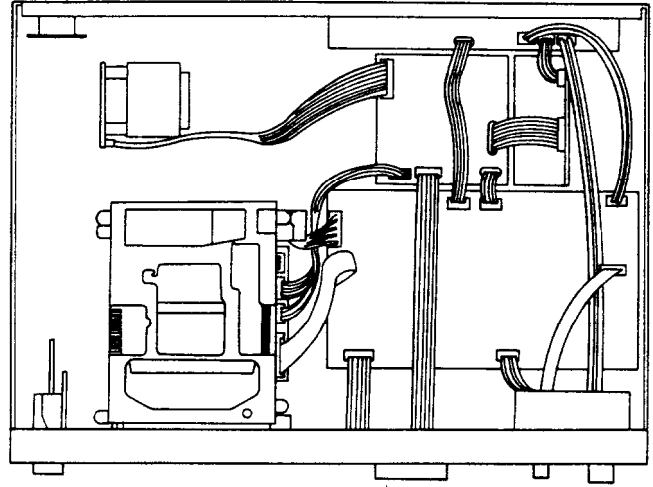

### • ELECTRICAL ADJUSTMENT

#### • Adjustment points

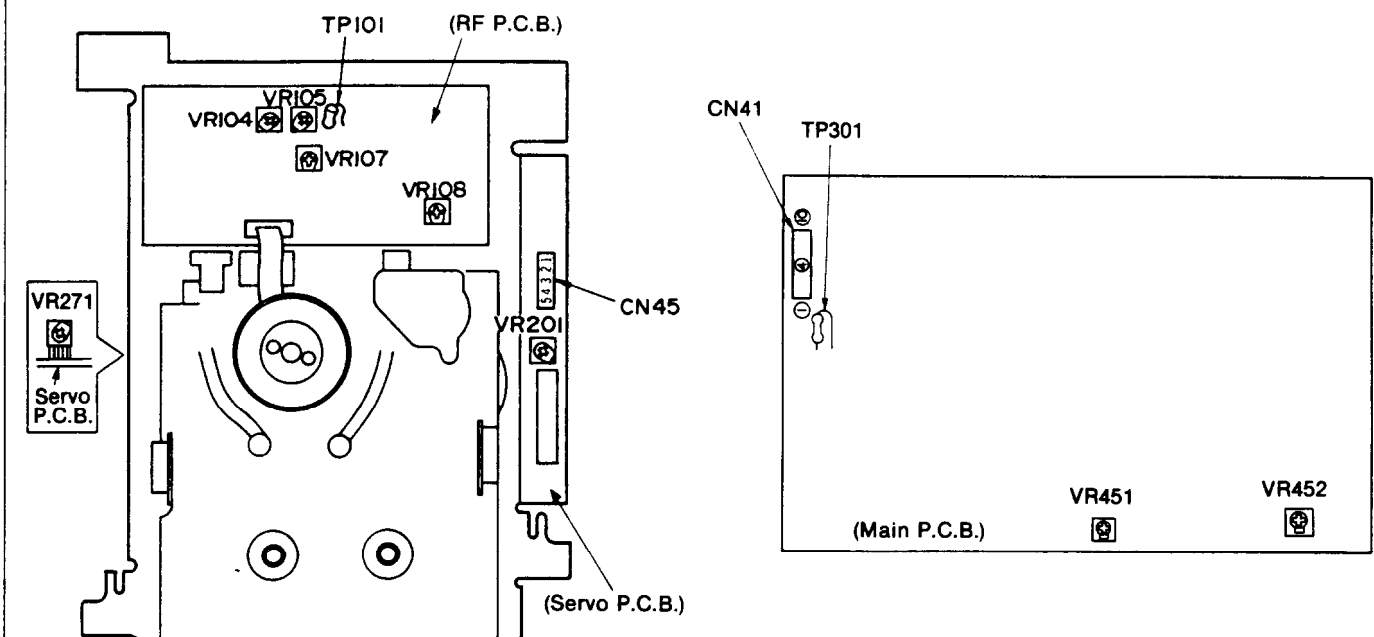

#### Equipment and Tools

- 2-channel 30 MHz oscilloscope (with external trigger and delay sweep) (with a 10 : 1 probe)
- Standard electrical tools and equipment
- Standard test tapes – RD-PG01 (PG reference), RD-ER01 (error rate)
- Blank tape for recording and playback (commercially available blank tape)
- Linearity adjusting tape: RD-LR02
- Post roller adjusting screwdriver: SZZV1102C
- Frequency counter

### 1. PLL Free Run Adjustment

1. Test equipment connection is shown in figure.
2. Power switch in "on" position.
3. Set the unit to cassette holder in "open" position.
4. Adjust **VR108** for  $9.2 \pm 0.2$  MHz on frequency counter reading.

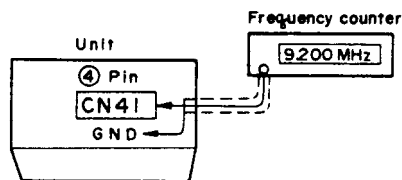

### 2. PG Phase Adjustment

1. Play the PG reference portion of the standard test tape (RD-PG01).
2. Set up the oscilloscope and connect as shown below.

	CH-1	CH-2
Test point	TP101 (RPRF)	TP301 (R3CP)
Volts/Div.	50mV	0.5V
Time/Div.	5msec.	
Delay	50μsec.	
Trig.	CH-2	
Mode	CHOP	
AC-GND-DC	AC	DC
Adjustment point	VR201	

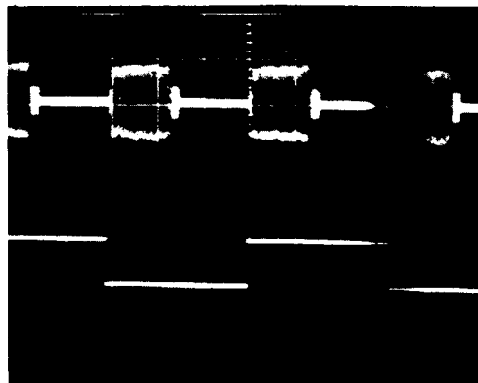

**Note:** GND is the shield plate of the RF circuit.

3. After set up, the waveform shown on the right appears.
4. The waveform in the figure on the right is enlarged using the delayed sweep. The point where the delayed sweep is used to enlarge the waveform is the leading edge of the CH-2 (R3CP) waveform.

Delayed sweep – 50μsec.

5. Adjust **VR201** (located on the servo P.C.B.) so that the time "t" (in the figure below) from the leading edge of the waveform of CH-2 to the leading edge of the 522kHz waveform of CH-1 it is within  $\pm 40\mu\text{sec}$  of the time indicated on the label of the standard tape (e.g.  $170\mu\text{sec}$ ).

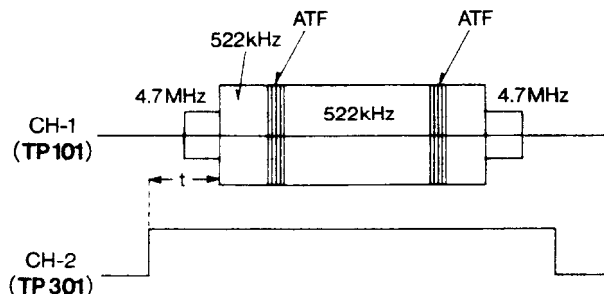
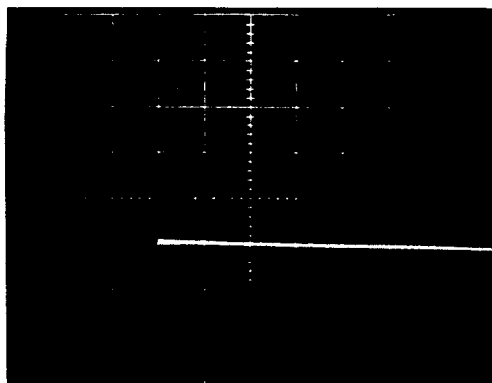
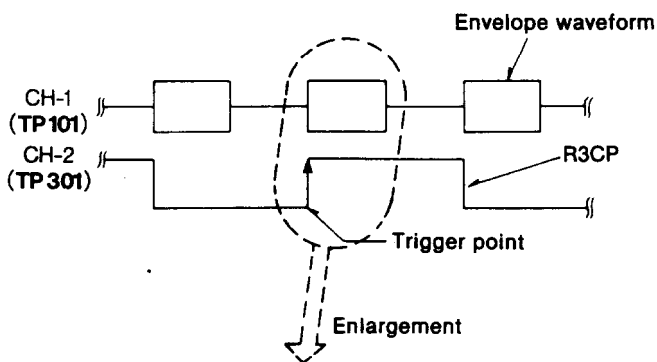

t: Value (μsec) indicated on the standard tape  $\pm 40\mu\text{sec}$ .

### 3. ATF Gain Adjustment

1. Play the **error rate measurement** standard test tape (RD-ER01).
2. Set up the oscilloscope and connect as shown below.

	CH-1	CH-2
Test point	CN45 ③ (PILOT)	TP301 (R3CP)
Volts/Div.	50mV	0.5V
Time/Div.	5msec.	
Delay	0.1msec.	
Trig.	CH-2	
AC-GND-DC	AC	DC
Adjustment point	VR107	

3. Monitor about 8 lines of the ATF waveform. Select the line with the largest amplitude and enlarge it using the 50 $\mu$ sec. delayed sweep.
4. Adjust VR107 so that the amplitude of the waveform is **1.4Vp-p** check that the other smaller amplitudes are **1.2Vp-p** or higher.

Standard value:  $1.4 \pm 0.2Vp-p$

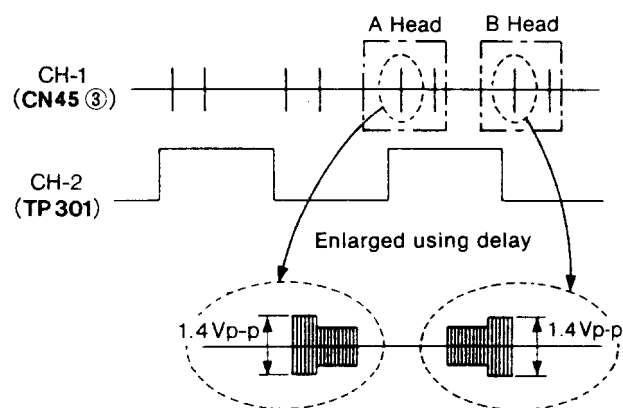
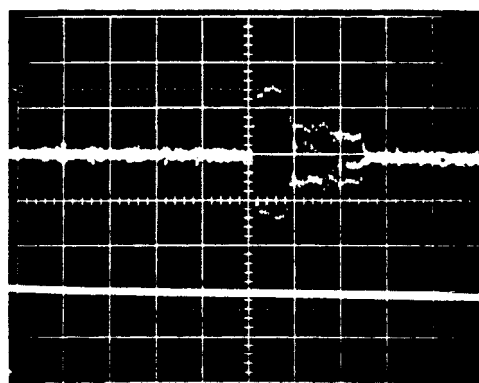

### 4. RF Recording Level Adjustment

1. Load a blank tape into the unit, place the unit in the REC-play mode, and make a blank signal recording for 10 to 15 sec. Rewind the tape and play back the recorded portion.
2. Connect and set up the oscilloscope as follows:

	CH-1	CH-2
Test point	CN45 ③ (PILOT)	TP301 (R3CP)
Volts/Div.	50mV	0.5V
Time/Div.	2msec.	
Delay	0.2msec.	
Trig.	CH-2	
AC-GND-DC	AC	DC
Adjustment point	VR104: Head A, VR105: Head B	

3. While playing back the erased portion of the tape, verify that the signal amplitude falls in the range of  $1.4 \pm 0.2Vp-p$ .

Standard value:  $1.4 \pm 0.2Vp-p$

4. If the signal amplitude is less than **1.2V**, turn VR104 (head A) or VR105 (head B) counter-clockwise until the amplitude falls into the specification. If it exceeds **1.4V**, turn the same variable resistors clockwise until the specification is met.
5. Repeat step 2 above again, then verify that the playback signal amplitude falls in the range specified in step 3.  
(Repeat step 2, 3 and 4 above until the specification is met.)

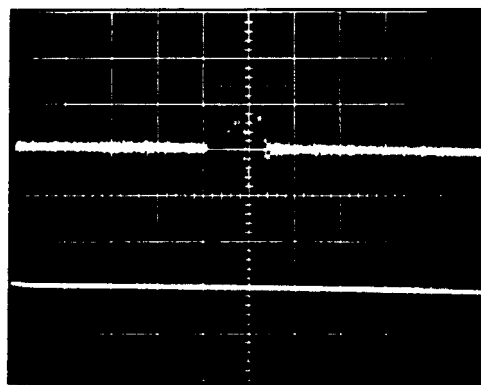

## 5. ADC Offset Adjustment

This adjustment is necessary when the indication of the level meter is abnormal.

1. Load a blank tape into the deck and place the deck in REC-PAUSE mode.
2. Adjust **VR451** (Lch) and **VR452** (Rch) so that the indication of the level meter is not illuminated.

## 6. BOT/EOT Detection Sensitivity Verification and Adjustment

1. Make sure that the tape stops with the leader portion (the beginning and ending portion).

※ If the tape does not stop at the leader, make adjustment by following procedure outlined below.

- ① Insert a blank tape into the tape compartment of the set and press the playback button at the end of the tape.
- ② Set up the oscilloscope and connect as shown below.

	CH-1	CH-2
Test point	<b>CN54</b> ⑥ (BOT/EOT) ⑨ (magnetic substance)	<b>CN58</b> ①
Volts/Div.	0.2V	0.2V
Time/Div.	2msec.	
Delay	—	
Trig.	CH-2	
AC-GND-DC	AC	DC
Adjustment point	<b>VR271</b>	

- ③ Adjust the amplitude of waveform to less than 1V at the magnetic substance and more than 4V at the leader on **VR271**.

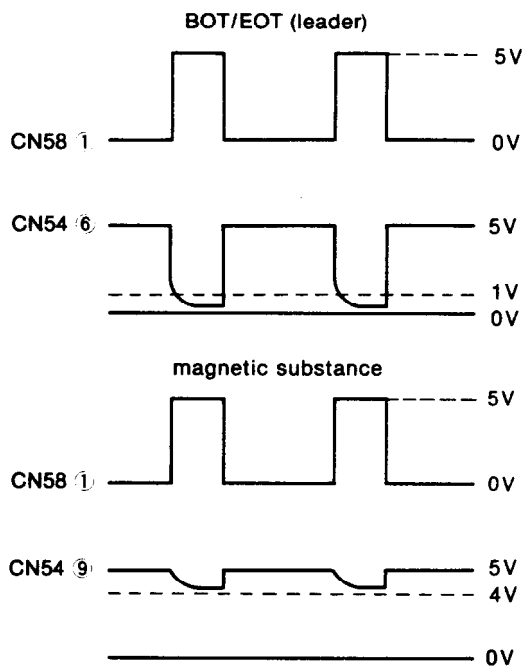

## 7. Linearity Adjustment

**Caution:** The post rollers are used for linearity adjustment. Gradually change the post roller heights until the RF signal envelope becomes rectangular.

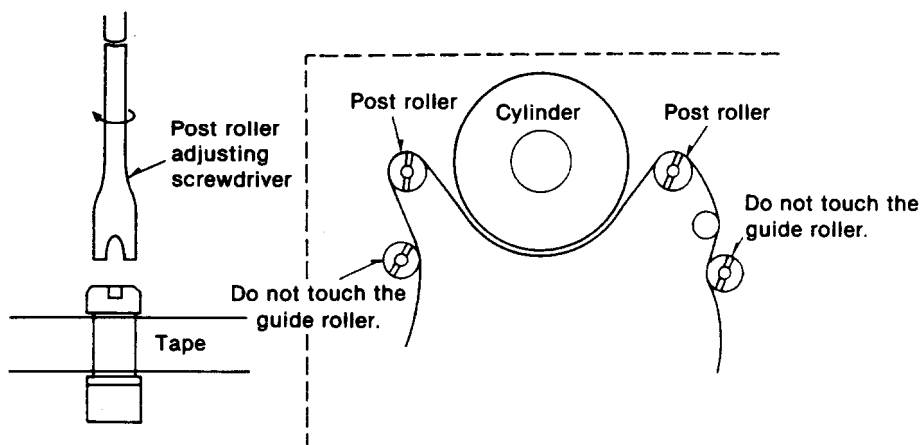

• DAT Linearity Adjustment

1. Load the linearity adjusting tape (RD-LR02) into the deck.
2. Connect and set up the oscilloscope as follows:

	CH-1	CH-2
Test point	CN45 ③ (PILOT)	TP301 (R3CP)
Volts/Div.	0.2V	2.0V
Time/Div.	Ⓐ 5msec. Ⓑ 1msec. Ⓒ 0.2msec.	
Delay	—	
Trig.	CH-2	
AC-GND-DC	AC	DC
Adjustment point	Post rollers	

3. Monitor the head "A" side of RF envelope waveform.

**Note:** When the waveform of TP301 (R3CP) is high, the envelope is output from the head "A".

4. While playing back the linearity adjusting tape, gradually adjust the **post roller** heights until the RF signal envelope ③ becomes rectangular.

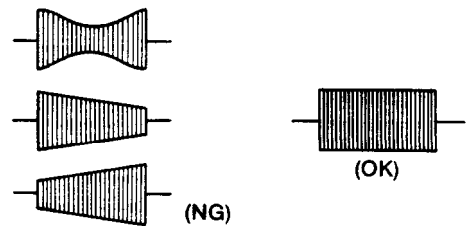
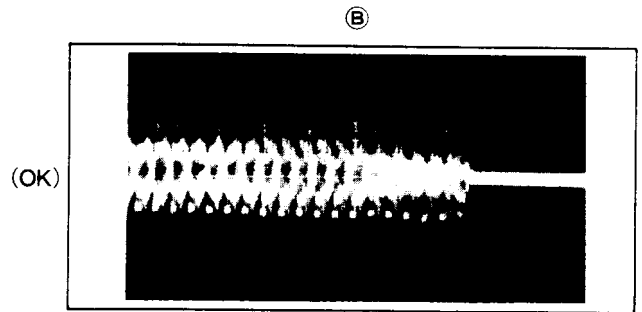
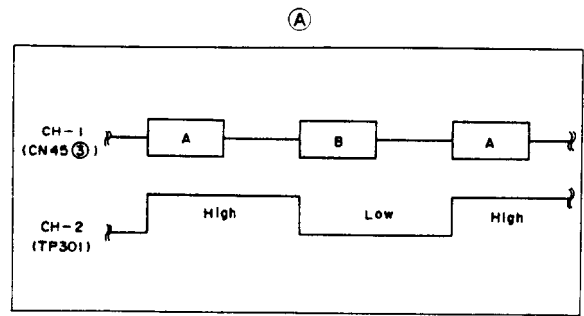

■ If the loading unit is to be removed for adjustment, note the following.

(PREPARATIONS)

- (1) Remove the loading unit. (With the underside facing up.)  
(Refer to Procedure 5 under "Disassembly Instructions." However, leave the flat cable and the connector as they are.)
- (2) Open the cassette holder.
- (3) Move the slider opening/closing plate of the removed loading unit in the direction indicated by the arrow in Fig. 1, and hook it above the prong of the reinforcement plate.

**Caution:** The slider opening/closing plate will be deformed if it is left as is.

- (4) Place a tape with the slider lock released in the mechanism.
- (5) Switch on the power and check the loading operation.

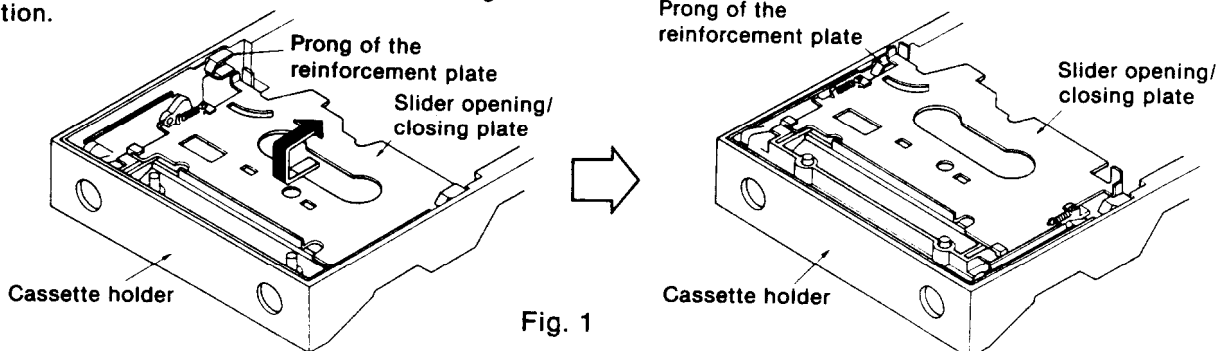
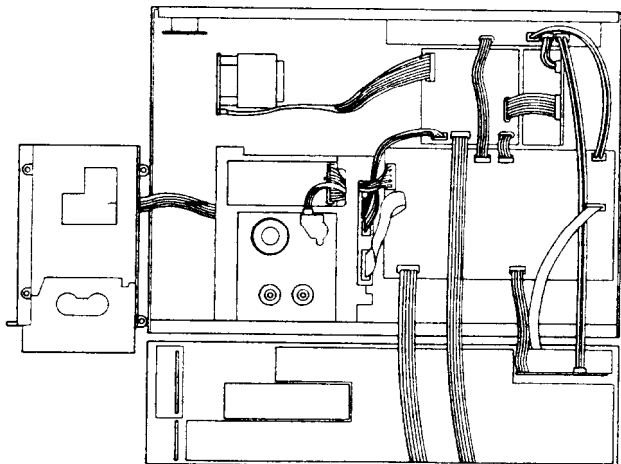

Fig. 1

## ■ TERMINAL FUNCTION OF IC'S

### • IC101 (AN7030SE2): RF AMP.

Pin No.	Mark	I/O Division	Function	Pin No.	Mark	I/O Division	Function
1	V <sub>CC</sub> 1	I	Power supply terminal	24	HSW	I	Head switching signal
2	ACH FB	O	Playback feed back signal (Ach)	25	AR/RSEL	I	Not used, connected to power supply
3	ACH IN	I	Playback amp. signal (Ach)	26	R/PSEL	I	Recording/playback select signal (REC: "H", PLAY: "L")
4	GND 1	—	GND terminal	27	EQ OUT	O	Equalization signal
5	BCH IN	I	Playback amp. signal (Bch)	28	EQ IN 3	I	Equalization amp. signal
6	BCH FB	O	Playback feed back signal (Bch)	29	EQ IN 2		
7	AREC PCM	I	RF recording level adj. terminal	30	EQ IN 1		
8	AREC PLT						
9	AREC ATF						
10	BREC ATF						
11	BREC PLT						
12	BREC PCM						
13	REC CNT 1	I	Track pitch signal	31	BF REQ	I	Equalization amplitude drive terminal (Bch)
14	REC CNT 2	I	ATF area det. signal	32	B PHASE	I	Equalization phase drive terminal (Bch)
15	SRRF IN	I	Recording signal	33	B GAIN	I	Equalization gain drive terminal (Bch)
16	GND 2	—	GND terminal	34	AF REQ	I	Equalization amplitude drive terminal (Ach)
17	VREF	O	Reference voltage terminal (Not used, open)	35	A PHASE	I	Equalization phase drive terminal (Ach)
18	AREC OUT	O	Recording signal (Ach)	36	A GAIN	I	Equalization gain drive terminal (Ach)
19	BREC OUT	O	Recording signal (Bch)	37	SV RF	O	Playback signal
20	BTL REC	O	Recording control signal	38	GND 3	—	GND terminal
21	V <sub>CC</sub> 2	I	Power supply terminal	39	A INT	I	Playback amp. signal (Ach)
22	REC ON	O	Recording drive terminal (REC: "H")	40	B INT	I	Playback amp. signal (Bch)
	PLAY ON	O	Playback drive terminal (PLAY: "H")	41	B INT IN	O	Playback amp. signal (Bch)
				42	A INT IN	O	Playback amp. signal (Ach)



• IC102 (AN7035SCE2): Playback PLL

Pin No.	Mark	I/O Division	Function
1	LPF	O	Buffer amp. 1 reference terminal
2	GND 1	—	GND terminal
3	ENVC	O	ENV time constant setting terminal
4	ENVR	I	ENV threshold voltage adj. terminal
5	RSENV	O	RF envelope signal
6	RSENV	O	RSENV time constant setting terminal
7	RSRF	I	RF signal
8	DELOUT	O	RF signal
9	DELIN 1	I	Delay (45°) signal
10	DELIN 2	I	Delay (90°) signal
11	PDOUT	O	Phase comparator signal
12	VREF 1	I	V/I converter reference voltage terminal
13	VCOV	I	OSC frequency control terminal
14	R/P	I	Recording/playback select terminal (Not used, connected to GND)
15	VCOR	I	OSC frequency adj. terminal

Pin No.	Mark	I/O Division	Function
16	V <sub>CC</sub> 1	I	Power supply terminal
17	VCOC 1	O	VCO terminal
18	VCOC 2	O	VCO terminal
19	V <sub>CC</sub> 2	I	Power supply terminal
20	PLL CP 1	O	Clock (2CK) signal (Not used, open)
21	PLL CP 2	O	Clock (CK) signal
22	DEMCOD	O	NRZI demodulated signal for playback signal with PLL
23	SVSYNC	O	ATF sync. signal
24	GND 2	—	GND terminal
25	OP OUT 3	O	ATF 3 signal
26	OP IN 3	I	ATF 3 signal
27	OP OUT 2	O	ATF 2 signal
28	OP IN 2	I	ATF 2 signal
29	OP OUT 1	O	ATF 1 signal
30	OP IN 1	I	ATF 1 signal
31	VREF 2	I	Reference voltage terminal
32	COMP 1	I	Output amp. 1 (+) signal

## • IC201 (MN6742SDR): Servo processor

Pin No.	Mark	I/O Division	Function
1	OP10A	O	Cylinder rotative stop signal
2	SCK	I	Serial clock signal
3	SDA	I/O	Serial data signal
4	OSC 1	I	System clock (8MHz) signal
5	OSC 2	O	
6	NRST	I	Reset signal
7	NC	—	Not connection
8	OP20A	O	SSP ready signal
9	NC	—	Not connection
10	V <sub>SS</sub>	—	GND terminal
11	VHS	—	Not used, open
12	OP 101	O	CAPFG/RLFGT select signal
13	TP 2	O	R3CP/RLFGT select signal
14	TP 3	I	PLL off-set/parallel data signal
15	TP 4		
16	TP 5		
17	TP 6		
18	TP 7	I	PLL off-set/data effective flag terminal
19	TP 8	I	Not used, connected to power supply
20	MOS	I	Serial port/strobe signal
21	TST	I	Test mode terminal (Normal, connected to GND)
22	ENC	—	Connected to GND terminal
23	NC	—	Not connection
24	NC		
25	V <sub>DD</sub>	I	Power supply terminal
26	NC	—	Not connection
27	RSW	—	Not used, open
28	HAS	O	A/D input select signal
29	AVM	—	Not used, connected to GND
30	VLP	—	Not used, open
31	STM	I	R3TU or RLFGT (64 P/R) signal
32	STR	I	Comparator reference signal of STM input

Pin No.	Mark	I/O Division	Function
33	CAE	O	Capstan velocity control signal
34	CYE	O	Cylinder velocity control signal
35	END	I	VREF or ATFTER voltage signal
36	VSY	I	CYLPG signal
37	ASH 1	I	Capstan FG or RLFGT signal after EXOR
38	NC	—	Not connection
39	AFB 1	O	Inverter amp. signal of ATFTER input (Not used, open)
40	NC	—	Not connection
41	AFG 1	I	ATF tracking error voltage terminal
42	ASH 2	O	Not used, connected to GND
43	AFB 2	O	Not used, open
44	NC	—	Not connection
45	AFG 2	I	Reference voltage terminal
46	VDA	I	Power supply terminal
47	VSA	—	GND terminal
48	ORE	O	Reference voltage terminal
49	IRE	I	
50	GND	—	GND terminal
51	IPL	O	Not used, open
52	NC	—	Not connection
53	CLP	I	Not used, connected to GND
54	CP 1	O	Not used, open
55	CP 2	I	Supply reel FG signal
56	NC	—	Not connection
57	NC		
58	CN 1	O	Not used, open
59	CN 2	I	Not used, connected to GND
60	CTL	O	Not used, open
61	PFG	I	Cylinder FG signal
62	PGM	I	Not used, connected to GND
63	CUL	O	Capstan rotative direction signal
64	NC	—	Not connection

## • IC202 (MN53020SDQ): ATF

Pin No.	Mark	I/O Division	Function	Pin No.	Mark	I/O Division	Function
1	NSNCOK	O	SYNC det. monitor terminal	22	TEST 6	—	Not used, connected to GND
2	SVAL	I	ATF select terminal	23	P MODE	I	Pulse width select terminal
3	PCMOK	I	PCM playback monitor terminal	24 28	TEST 1 TEST 5	I	Test terminal (Not used, connected to GND)
4	SPE	O	Starting pulse of counter track lock	29	SPHT	—	Not used, open
5	SP 2	O	Sampling pulse signal for pilot signal of adjacent track	30	HSWS	O	Head switching signal (33.33Hz)
6	SP 1			31	HSWR		
7	DCYLPG	I	Cylinder PG signal	32	SEL A	I	CAPFGTU signal select terminal
8	DCAPFG 1	I	Capstan FG signal	33	SEL B	I	R3TU signal select terminal
9	DCAPFG 2						
10	DRLFGT	I	Take-up reel FG signal	34	PLL 0	O	Output signal after decoded 4 bit parallel data of PLL0FS
11	DCYLFG	I	Cylinder FG signal	35	PLL 1		
12	SYNC	I	ATF sync. det. terminal	36	PLL 2		
13	NRST	I	Reset signal	37	PLL 3		
14	R3CP	I	Timing signal for RF envelope signal control	38	MODE 2	—	Not used, open
15	ENVT						
16	FCH	I	System clock signal (9.408 MHz)	39	V <sub>SS</sub> 2	—	GND terminal
17	V <sub>DD</sub>	I	Power supply terminal	40	V <sub>DD</sub> 2	I	Power supply terminal
18	V <sub>SS</sub>	—	GND terminal	41	R3TU	O	Building-up edge signal of R3CP/DRLFGT
19	MODE 1	I	SYNC det. select terminal (Not used, connected to GND)	42	CAPFGTU	O	Capstan FG signal/Take-up reel FG signal
20	HFCH	I	Clock signal for PLL off-set data	43	CAPER	O	Capstan rotative direction control signal
21	PLLOFS	I	PLL off-set data signal	44	NLNROK	O	Track linearity monitor terminal

## • IC203 (AN8320NFA): Linear servo

Pin No.	Mark	I/O Division	Function	Pin No.	Mark	I/O Division	Function
1	FG1 AO	O	Capstan FG signal	26	LEDH 2	—	Constant current terminal (Not used, open)
2	FG1 AI	I	Capstan FG (-) signal	27	CYL FG	O	Cylinder FG signal
3	FG1 FI	—	Frequency characteristic setting terminal	28	CYF GSI	I	Cylinder schmidt comparator terminal
4	CYL PG	O	Cylinder PG signal	29	CYF GAO	O	Cylinder op. amp. terminal
5	PGVR	—	PG delay time adj. terminal	30	CYF GAI	I	Cylinder op. amp. (-) terminal
6	CYPGI	I	PG schmidt comparator terminal	31	NST BY	I	STAND BY signal (Not used, connected to power supply)
7	GND	—	GND terminal	32	TF GAI	I	Take-up reel op. amp. (-) terminal
8	SVRF	I	ATF terminal	33	TF GAO	I	Take-up reel op. amp. terminal
9	CPD	—	Det. capacity connection terminal	34	TF GSI	I	Take-up reel schmidt comparator terminal
10	CCI	O	Full-wave rectification buffer terminal	35	RLFGT	O	Take-up reel FG signal
11	CCO	I	Clamp circuit terminal	36	RLFGS	O	Supply reel FG signal
12	SP 1	I	SP 1 terminal	37	SF GSI	I	Supply reel schmidt comparator terminal
13	SP 2	I	SP 2 terminal	38	SF GAO	O	Supply reel op. amp. terminal
14	VSPE	—	SPE setting terminal	39	SF GAI	I	Supply reel op. amp. terminal
15	SPE	I	SPE terminal	40	V <sub>cc</sub>	I	Power supply terminal
16	CSH	I	Hold capacity connection terminal	41	FG 2FI	—	Frequency characteristic setting terminal
17	ATFTER	O	ATF control command signal	42	FG 2AI	I	Capstan FG (-) signal
18	CFB	—	Phase compensation terminal	43	FG 2AO	O	Capstan FG signal
19	V <sub>cc</sub>	I	Power supply terminal	44	FG 2SI	I	Capstan FG schmidt comparator terminal
20	ATFON	I	ATF ON terminal (Not used, connected to power supply)	45	CPFG 2	O	Capstan FG signal
21	PTBIA	—	Photo-transistor bias terminal (Not used, open)	46	FILSLD	I	Frequency characteristic DOWN terminal
22	VREF	O	Reference voltage terminal	47	CPFG 1	O	Capstan FG signal
23	LEDR 1	I	Bias voltage terminal	48	FG 1SI	I	Capstan FG schmidt comparator terminal
24	LEDH 1	—	Constant current terminal (Not used, open)				
25	LEDR 2	I	Bias voltage terminal				

• IC271 (MN17541SDN2): Mechanism control

Pin No.	Mark	I/O Division	Function
1	NSBOA	O	Serial data signal
2	NRST	I	Reset signal
3	NSYNC	—	Not used, open
4	X 2		
5	X 1		
6	V <sub>SS</sub>	—	GND terminal
7	OSC 2	—	Not used, open
8	OSC 1	I	Clock signal
9	V <sub>DD</sub>	I	Power supply terminal
10	NTC1B	I	Supply reel FG signal
11	NIRQ 0	I	Take-up reel FG signal
12	NIRQ 1	I	Transfer strobe signal of system control
13	P00 (MSTB)		
14	P 01 (MRDY)	O	Transfer ready signal of system control
15	P 02 (NSSTB)	O	Transfer strobe signal
16	P 03 (NSRDY)	I	Transfer ready signal
17	P 10 (ATFGT)	O	ATF gain (× 1/2) select terminal
18	P 11 (REWGT)	O	REW FG · PG gain select terminal
19	P 12 (LPMOD)	—	Not used, open
20	P 13 (MODMT0)	O	Mode motor control signal
21	P 20 (MODMT1)		
22	P 21 (MODMT2)		
23	P 22	—	Not used, open
24	P23 (PLG)	O	Plunger control signal
25	P 30	—	Not used, open
26	P 31		
27	P 32 (LOAD 1)	O	Tray motor control (+) terminal
28	P 33 (LOAD 2)	O	Tray motor control (−) terminal
29	P 40	—	Not used, open
30	P 41 (DEW)	I	Dew sensor det. signal
31	P 42 (EOT)	I	Tape end det. signal
32	P 43 (BOT)	I	Tape begin det. signal
33	P 50 (OPEN)	I	Cassette open det. signal

Pin No.	Mark	I/O Division	Function
34	P 51 (CLOSE)	I	Cassette close det. signal
35	P 52 (LOAD S)	I	Loading start det. signal
36	P 53 (LOAD E)	I	Loading stop det. signal
37	P 60 (SW 2)	O	Test terminal
38 }	P 61 (MMOD 0)	I	Tape mode det. signal
40	P 63 (MMOD 2)		
41 }	P 70 (MBUS 0)	I/O	Transfer bus terminal of system control
44	P 73 (MBUS 3)		
45	P 80 (RCC)	—	Not used, open
46	P 81 (FIL)	O	FILTER select signal
47	P 82 (ATFON)	—	Not used, open
48	P 83 (NSTBY)	—	Not used, open
49	P 90 (NSRST)	O	Reset signal
50	P 91 (LEDDRV)	O	Tape begin/end LED control signal
51	P 92 (PCMOK)	I	PCM playback det. signal
52	P 93 (SVAL 0)	I	ATF effective position setting terminal
53	NEXPS	I	Not used, connected to power supply
54	PA 0 (NSNCOK)	I	ATF sync. det. terminal
55	PA 1 (NLNOK)	I	Track linearity det. terminal
56	PA 2 (CAPER)	I	Capstan rotative direction command signal
57	PA 3	—	Not used, open
58	PB 0 (TH 1)	I	Tape hall det. signal
59	PB 1 (TH 2)		
60	NSBTB	I	Muting det. signal
61	NSBIB	I	Test terminal
62	NSBOB		
63	NSBTA (SCLK)	I	Serial transfer clock signal
64	NSBIA (SDAT)	I/O	Serial transfer data signal

## • IC301 (MN188161SDS4): System control

Pin No.	Mark	I/O Division	Function
1	V <sub>DD</sub>	I	Power supply terminal
2 3 9	P 67 (SPDT 7) P 60 (SPDT 0)	I/O	Signal processor transfer address and data bus terminal
10	P 57 (SPRDY)	I	Signal processor data transfer command signal
11	P 56 (PBLANK)	I	Blank skip select ("H": no skip, "L": skip)
12	P 55 (R3CP)	I	Frame sync. signal
13	P 54 (PMID6B)	—	Main ID6 select terminal
14	P 53 (PMID6A)		
15	P 52	I	Not used, connected to resistor
16	P 51	I	Not used, connected to resistor
17	P 50 (PDIOSEL)	I	D I/O select ("H": AES/EBV, "L": IEC)
18	EXI	—	Not used, connected to GND
19	EXO	—	Not used, open
20	NRST 1	I	Reset signal ("L": RESET)
21	P 47 (NSERVST)	O	Reset signal to servo block
22	P 46	—	Not used, open
23	P 45	—	
24	P 44	—	
25	P 43 (SLAD)	O	DIGITAL IN PLL/crystal select terminal ("L": PLL, "H": crystal)
26	P 42 (XCK32)	O	32kHz OSC control ("H": OSC, "L": STOP)
27	P 41 (XCK44)	O	44.1kHz OSC control ("H": OSC, "L": STOP)
28	P 40 (XCK48)	O	48kHz OSC control ("H": OSC, "L": STOP)
29	P 27 (NPRDY)	I	Transfer ready signal from panel control
30	OSC 1	I	Crystal OSC terminal
31	OSC 2	O	
32	V <sub>SS</sub>	—	GND terminal
33	XI	—	Not used, open
34	XO	—	
35	P 26	—	Not used, connected to power supply
36	P 25 (RF ENV)	I	RF envelope signal

Pin No.	Mark	I/O Division	Function
37	P 37 (FLGCLK)	O	Clock signal of flag counter
38	P 36 (FLGDT)	O	Data signal of flag counter
39	P 35 (TP)	O	Track pitch signal ("L": normal)
40	P 34 (UNLOCK)	O	DIGITAL-IN PLL unlock signal ("L": det.)
41	P 33	—	Not used, open
42	P 32 (DISCHG)	O	DIGITAL-IN PLL discharge signal
43	P 31 (DINPLINH)	O	DIGITAL-IN PLL prohibition signal ("H": prohibition)
44	P 30 (ANRST)	O	Reset signal ("H": RESET) to DAC
45	P 21 (HSW)	I	Head switching pulse signal
46	P 20 (NMRDY)	I	Transfer command signal from mechanism control
47	P 01	—	Not used, open
48	P 00	—	
49	P 17 (PTXD)	O	Serial data transmission terminal
50	P 16 (PRXD)	I	Serial data reception terminal
51	P 15 (PCLK)	O	Serial data transmission/reception clock signal
52	P 14	—	Not used, open
53 56	P 13 (MDT 3) P 10 (MDT 0)	I/O	Transfer data bus of mechanism control
57	P 77	—	Not used, open
58	P 76 (NDEMP)	O	de-emphasis signal
59	P 75 (SGMTG)	O	Muting signal
60	P 74 (DOUTTH)	O	Digital out through select ("H": through)
61	P 73 (NRST 2)	O	Reset signal
62	P 72 (MSTB)	O	Transfer command terminal of mechanism control
63	P 71 (SPSTB)	O	Signal processor strobe signal
64	P 70 (SPAW)	O	Signal processor address setting signal

Pin No.	Mark	I/O Division	Function
29 }	IC	—	Not used, open
35			
36	NC	—	Not connection
37	NSUB	—	Not used, connected to power supply terminal
38	TV <sub>DD</sub>	I	Power supply terminal

Pin No.	Mark	I/O Division	Function
39	DOUT	O	Digital data signal
40	TV <sub>SS</sub>	—	GND terminal
41	TEST	I	Test terminal (Connected to power supply)
42	DV <sub>SS</sub>	—	GND terminal

• IC501 (MN6470): Digital filter & D/A converter

Pin No.	Mark	I/O Division	Function
1	MLD	I	Microcomputer command load signal (Not used, connected to power supply)
2	RSB	I	Reset terminal ("L": reset)
3	IE	I	Not used, connected to GND
4	TP1	O	Test terminal
5	TP2		
6	TEST 1	I	Test terminal (Connected to GND)
7	TEST 2		
8, 9	NC	—	Not connection
10	V <sub>DD</sub> 4	I	Power supply terminal
11	OUT L-	O	Lch (-) data signal
12	A V <sub>SS</sub> 4	—	GND terminal
13	A V <sub>SS</sub> 3		
14	OUT L+	O	Lch (+) data signal
15	A V <sub>DD</sub> 3	I	Power supply terminal
16	NC	—	Not connection
17	A V <sub>DD</sub>	I	Power supply terminal
18	OUT R+	O	Rch (+) data signal
19	A V <sub>SS</sub>	—	GND terminal
20	A V <sub>SS</sub>		
21	OUT R-	O	Rch (-) data signal
22	A V <sub>DD</sub>	I	Power supply terminal
23	D V <sub>DD</sub>	I	Power supply terminal
24	D V <sub>SS</sub>	—	GND terminal

Pin No.	Mark	I/O Division	Function
25	X2	I	Crystal OSC terminal
26	X1		
27	NC	—	Not connection
28	D V <sub>DD</sub>	I	Power supply terminal
29	D V <sub>SS</sub>	—	GND terminal
30	NSUB	I	Sub straight terminal (Not used, connected to power supply)
31	ZFLGB	O	Zero det. terminal
32	128FS	—	Not used, open
33	LRPOL	I	LR clock polarity select terminal (Not used, connected to GND)
34	LRCLK	I	LR discrimination signal
35	BCLK	I	Serial bit clock signal
36	SRDATA	I	Serial data signal
37	D V <sub>SS</sub>	—	GND terminal
38	D V <sub>DD</sub>	I	Power supply terminal
39	256FS	O	256fs signal
40	PD	I	Power down terminal (Not used, connected to GND)
41	MDATA	I	Microcomputer command data signal (Not used, open)
42	MCLK	I	Microcomputer command clock signal (Not used, connected to power supply)

• IC601(M50754-164EP): Panel control & FL drive

Pin No.	Mark	I/O Division	Function	
1	V <sub>SS</sub>	—	GND terminal	
2	P 27	O	Input select signal (DIGITAL↔ANALOG)	
3	P 26	O	LED display drive terminal (PAUSE)	
4	P 25	O	LED display drive terminal (REC)	
5	P 24	O	LED display drive terminal (PLAY)	
6 7 8	P 23 P 22 P 21	I	Key return signal	
9	P 20	O		Buffer control signal
10	NC	—		Not connection
11	NPRDY	O	Ready signal	
12	NTRCLK	I/O	Serial data transmission/reception clock signal	
13	RXD	O	Serial data transmission signal	
14	TXD	I	Serial data reception signal	
15 16	P 33 P 32	—	Not connection	
17	P 31	O		LED display drive terminal (S. PLAY)
18	P 30	O	LED display drive terminal (A. PNO)	
19	INT 1	I	RI input/output	
20	INT 2	I	Remote control signal	
21	CNV <sub>SS</sub>	—	GND terminal	
22	RST	I	Reset signal ("L": RESET)	
23	NC	—	Not connection	
24	X IN	I	Master clock terminal (6MHz)	
25	X OUT	O		
26	NC	—	Not connection	
27	X CIN	—	Not used, connected to GND	
28	X COUT	—	Not used, open	
29	V <sub>SS</sub>	—	GND terminal	
30	NC	—	Not connection	
31 32	P 57 P 56	I	Key return signal	

Pin No.	Mark	I/O Division	Function				
33	P 55	I	Key return signal				
34	P 54						
35	VP	I	Power supply terminal for FL drive				
36 37	P 51 P 50	O	Segment signal for FL drive				
38 39 40 41 42 43 44 45	P 17 P 16 P 15 P 14 P 13 P 12 P 11 P 10						
46	NC			—	Not connection		
47 48 49 50 51 52 53 54 55 56 57 58 59 60 61 62	P 07 P 06 P 05 P 04 P 03 P 02 P 01 P 00 P 47 P 46 P 45 P 44 P 43 P 42 P 41 P 40	O	Segment signal for FL drive				
63	V <sub>CC</sub>			I	Power supply terminal		
64	V <sub>CC</sub>						
65	V <sub>SS</sub>			—	GND terminal		
66 67 68 69 70 71	P 65 P 64 P 63 P 62 P 61 P 60			O	Digit signal for FL drive and key scan signal		
72	NC					—	Not connection



# ■ TROUBLESHOOTING

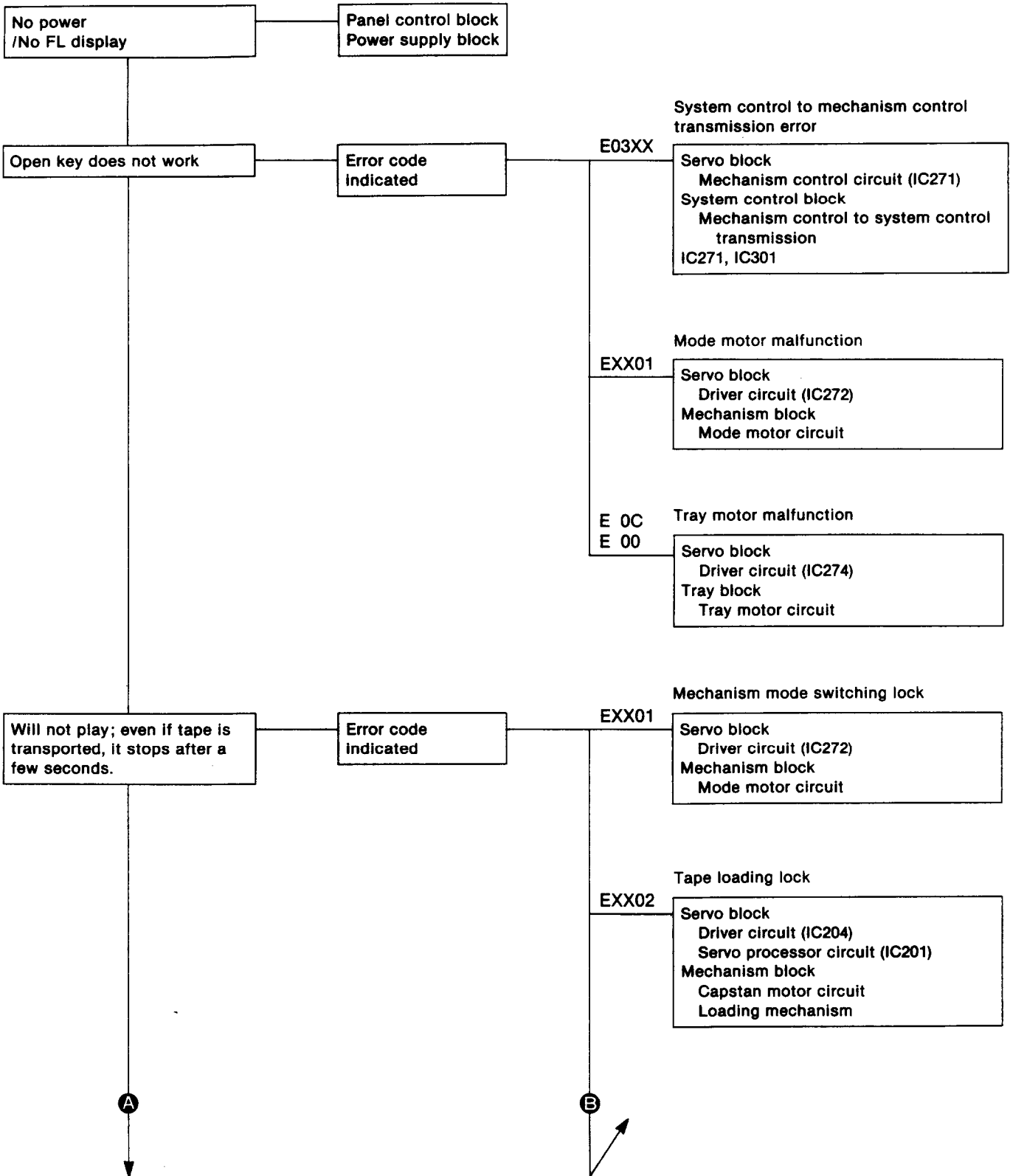

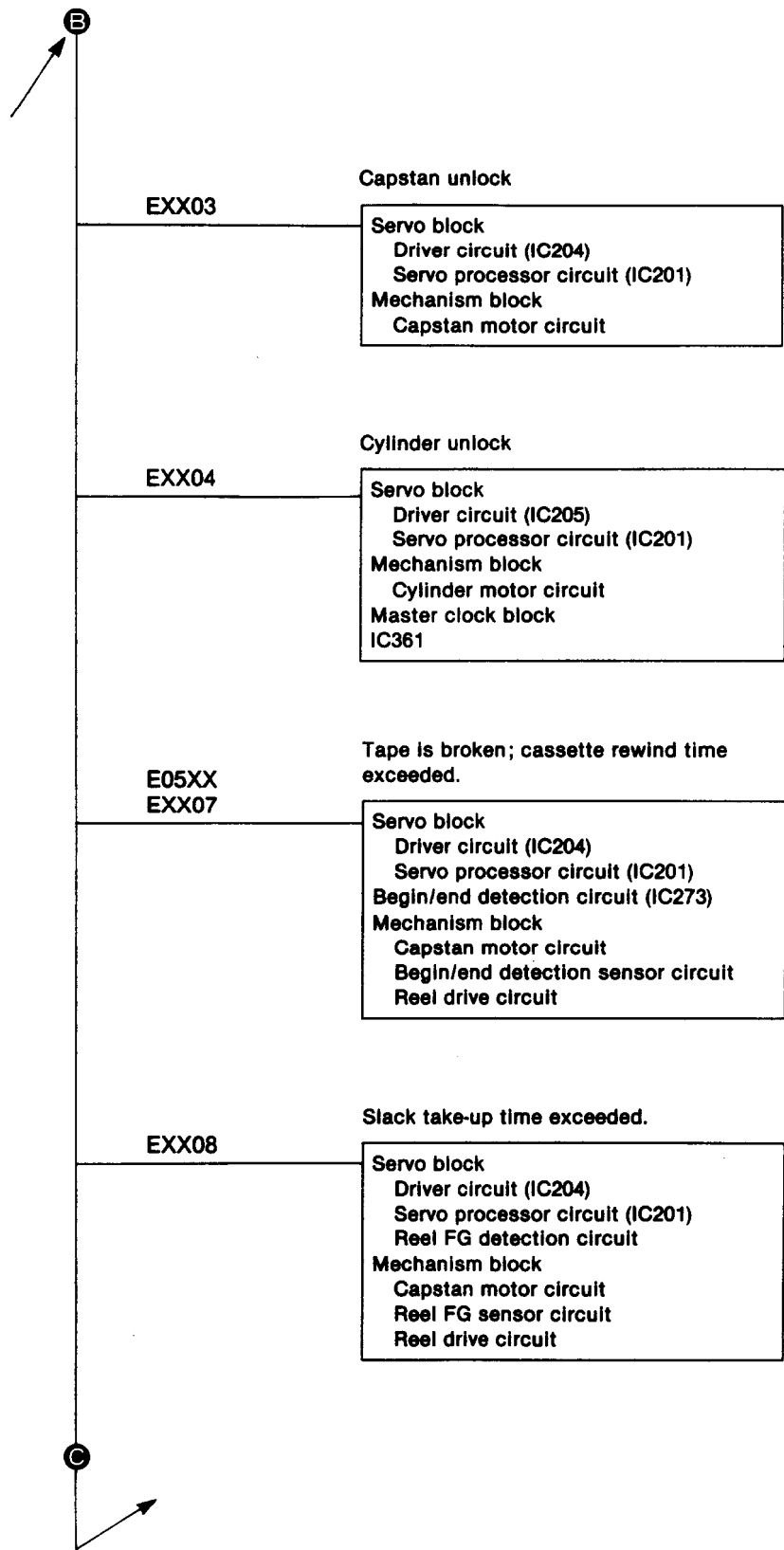

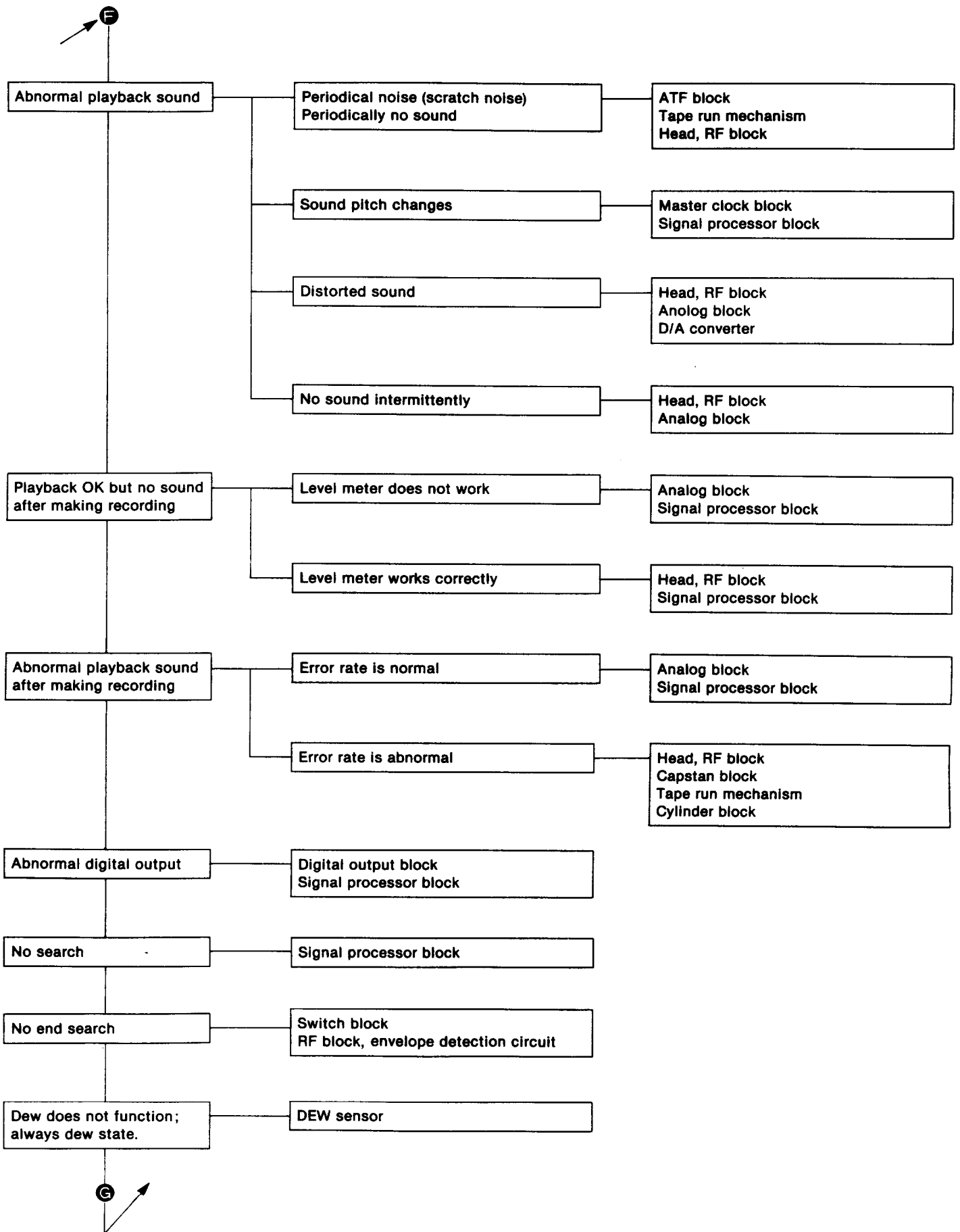

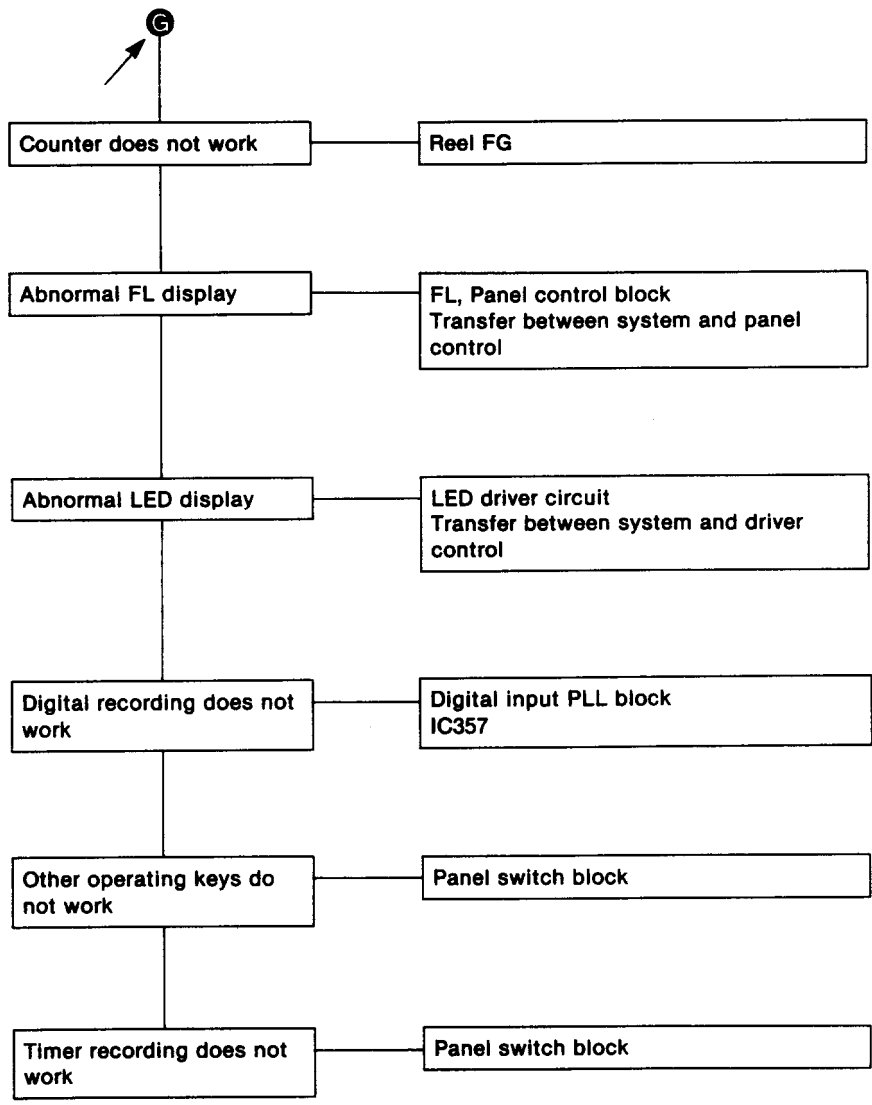

## ■ KEY POINTS FOR TROUBLESHOOTING

### Mechanism block

Loading mechanism  
   Post roller  
   Tension regulator  
   Pinch roller  
   Brake lever  
 Brake mechanism  
   Brake lever  
   Solenoid  
   Solenoid driver  
 Mechanism switch block  
   Tape hole detection switch  
   Cassette detection switch  
   Holder switch  
 Reel FG block  
   Detection photo transistor  
   Detection LED  
   Reel FG amp (servo P.C.B.)  
 FPC & FPC connector

### Mode motor block

Mode motor  
 Mode switch  
 Mode motor driver circuit

### Master clock block

28MHz oscillator  
 16MHz, 22MHz, 24MHz oscillate and select circuit

### Panel switch block

Switch  
 Panel control IC

### Head, RF block

Head FPC & FPC connector  
 Head dirty  
 Head cracked or damaged  
 RF recording current  
 Playback eye pattern

### Tape begin/end detection block

Begin/end detection photo transistor  
 Begin/end detection LED  
 Comparator circuit  
 FPC & FPC connector

### Power supply block

Power supply regulator output  
 Fuse

### Capstan block

Capstan FG  
 FG amp  
 Motor driver output  
 Motor current

### Cylinder block

Cylinder FG  
 Cylinder PG  
 FG amp  
 PG amp  
 Motor driver output  
 Motor current

### ATF block

RF ATF output  
   ATF SYNC output  
 ATF select circuit  
 ATF gate allay

### Signal processor block

Data & clock to D/A  
 Data & clock to A/D  
 All clocks

### Digital output block

Digital output PB

### Panel control block

Panel control block  
 Transfer between panel and system control  
 Panel control reset

### Analog block

Input amplifier  
 Output amplifier  
 Muting circuit  
 A/D converter  
 D/A converter

## ■ ABOUT THE ERROR RATE

If the error rate is normal, it can be judged that everything up to signal processing, meaning the operation of the RF head mechanism, is normal.

Thus, when there is a problem with playback, if the error is normal, it can be assumed that the origin of the problem is in the analog system.

## ■ ABOUT THE LEVEL METER

Just as for the error rate, if the level meter is operating normally, it indicates that the signal is reaching signal processing.

In other words, if there is no problem with the level meter during playback, it indicates that the head and the RF are outputting the signal.

In addition, if there is no problem with the level meter during recording, it indicates that the analog system (input amplifier and AD) is functioning normally.

## ■ ERROR DISPLAY AND PROBLEM LOCATION

### Display procedure

Simultaneously press the counter mode key, the counter reset key, and the pause key. The various internal data will be indicated in the counter section of the fluorescent lamp display.

There are four types of data as shown below; the data indicated will change each time the counter mode key is pressed.

① Total error rate for head A and head B.	"A" and "B" will light up in the repeat indication of the fluorescent lamp display.
② Error rate for head A	"A" will light up in the repeat indication of the fluorescent lamp display.
③ Internal code for microcomputer processing	
④ Error codes for system control (left) and mechanism control (right) (Refer to the next page.)	"E" will light up in the farthest left digit of the counter.

To return to the normal display mode, press the counter reset key.  
Note that the error codes will be cleared when the tray is opened.

## ■ ERROR CODE TABLE

Error code (Note. 1)	System control error code		Mechanism control error code	
	Processing (Note 2)	Contents	Processing (Note 2)	Contents
1	Test operation	R3CP clock malfunction	Unload	Mechanism mode switching lock
2	Test operation	HSW clock malfunction	Unload	Tape loading lock
3	Transmission omitted	Faulty transmission of the mechanism control	Unload	Capstan unlock
4	Unload	Still protection during operation	Unload	Cylinder unlock
5	Unload	Broken tape	Unload	Reel unlock
6	Unload	Faulty transmission of SP1	Unload	Sum of reel cycles cannot be measured.
7			Unload	In-cassette rewind time exceeded.
8			Unload	Slack tape-up time exceeded.
9			Unload	Tape jamming (Supply side)
A			Unload	Tape jamming (Take-up side)
B (-)			Unload	Gear does not engage.
C			Tray stop	Initial tray setting not possible.
O		—		No error
FF (blank)		No error		—

### Note 1: Display mode

E	X1	X2
---	----	----

E: Indicates that mode is the error rate display mode.

X1: System control error code

X2: Mechanism control error code

### Note 2: Processing when an error occurs

Test operation:

Internal clock of the system control temporarily connects for operation.

Transmission omitted:

Transmission processing stopped.

Unload:

Tape is unloaded.

## ■ DAT MAINTENANCE CHART

### • DAT Head and Tape Transport Cleaning

Through normal usage of any tape machine, dirt and debris from the tape accumulates on the heads, which eventually causes performance problems. By using a cleaning cassette regularly, dirt buildup can be minimized, prolonging the life of the tape heads, and also keeping tape posts, tape guides, and the pinch roller clean.

### • CLEANING

1. Play the cleaning cassette (Panasonic Part No. RT-RCLP) for 15-20 seconds.
2. Do not use the same part of the cleaning tape more than once.
3. Clean all tape contact surfaces, including the upper and lower drum, thoroughly with a soft cloth soaked in alcohol.
4. Clean both heads by gently rubbing in a horizontal direction, as depicted, using a head cleaning stick (VFK27) or a lint free cloth moistened with alcohol.
5. Wipe all tape contact surfaces, including upper and lower drum, with a dry soft cloth to ensure that all residual moisture is removed from the tape contact surfaces.

### Note:

1. When cleaning the upper drum, hold it secure by the top edges with your finger tips.
2. Occasionally, dirt or debris may become lodged in the air bearing channels that are cut in the upper drum's surface. This can be removed by gently dislodging it with a sharpened toothpick.
3. The amount of solvent applied to the head drum should be used in moderation. Excess alcohol will dilute and remove the bearing lubricant in the capstan motor and rotary guides.

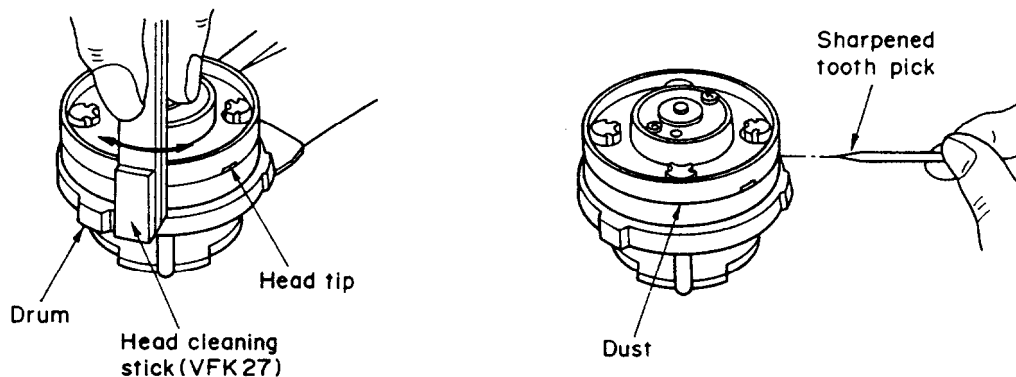



## • MECHANISM CONTROLS AND FUNCTIONS

① LIGHT HOUSE TYPE RADIATION LED	Lighthouse-shaped, LEDs blink at start and end of tape.	⑮ IDLER GEAR	Transmits movement to S and T reels in accordance with mode.
② CYLINDER	30mm in diameter, 40 FG pulses, maintains specified speed of 1000 to 3000rpm.	⑯ BT LEVER	Applies back tension to T reel during review.
③ T. POST ROLLER	Regulates tape travel position (upper edge).	⑰ BT SPRING	Provides pressure for back tension lever.
④ T. INCLINED BASE (FIXED)	Regulates angle (90°) at which tape is wound around cylinder (stationary).	⑱ S. BRAKE	Presses brake shoe against S reel base gear to perform braking.
⑤ T. STOPPER	Determines position of T post roller base during loading.	⑳ S. REEL (SUPPLY SIDE)	Supply reel base, 64 FG pulses.
⑥ LOAD SW	Two-bit rotary switch, detects loading position.	㉑ MODE MOTOR	6.5V DC motor, switches mode by forward and reverse revolution.
⑦ PINCH ROLLER	Presses against tape during play and review.	㉒ TENSION SPRING	Provides back tension force of tension regulator.
⑧ T. FIXED POST	Regulates tape travel position.	㉓ TENSION BAND	Mounted to tension regulator, applies back tension to S reel base.
⑨ CAPSTAN MOTOR	1.5mm in diameter, 290 FG pulses.	㉔ TENSION ARM	Detects tape condition and applies back tension during play and review.
⑩ LOAD HOLDER	Contains loading drive gear and worm gear, engages and disengages M gear A.	㉕ END DET. SENSOR	Light-receiving element for LED (detection at end of tape).
⑪ T. GUIDE ROLLER	Regulates tape travel position (top edge).	㉖ DATUM PIN	Regulates width and height (left side) during loading of cassette tape.
⑫ DATUM PIN	Regulates width and height (right side) during loading of cassette tape.	㉗ LID OPENER	Opens cassette lid during loading of tape.
⑬ GUIDE ARM STOPPER	Determines position of T guide roller base K during loading.	㉘ S. GUIDE ROLLER	Regulates tape travel position (bottom edge).
⑭ LOAD SELECT LEVER	Switches engagement and disengagement of loading gear in accordance with loading conditions.	㉙ S. FIXED POST	Regulates tape travel (bottom edge).
⑮ BEGIN DET. SENSOR	Light-receiving element for LED (detection at start of tape).	㉚ S. POST ROLLER	Regulates tape travel position (top edge).
⑯ PINCH LEVER	Presses pinch roller against tape during play and review.	㉛ S. STOPPER	Determines position of S post roller base during loading.
⑰ GUIDE LINK	Links T post roller base and guide roller base.	㉜ LOADING CAM	Uses movement transmitted from loading worm to move loading lever.
⑱ PINCH ARM	Comprised of pinch roller and T holding post, presses against the capstan.	㉝ LOADING WORM	Transmits movement of loading drive gear and loading cam.
⑲ PIN-PRESSURE LINK	Connected by the pin pressure spring and the pinch arm.	㉞ LOAD DRIVE GEAR	Transmits movement of M gear A and loading worm, engages and disengages in accordance with mode.
㉑ T. REEL (TAKE UP SIDE)	Take-up reel base, 64 FG pulses.	㉟ MR DET. ELEMENT	Detects magnetic changes (290 pulses) of flywheel.
㉒ CASSETTE SW	Detects cassette information (mistaken erasure, cassette detection).	㊱ PINCH ROLLER SPRING	Mounted to the pinch arm, returns the pinch roller.
㉓ T. BRAKE	Presses brake gear against reel base gear to perform braking.	㊲ LOAD GUIDE HOLDER	Holding cover of the loading arm and loading lever.
㉔ IDLER GUIDE	Holding cover for idler arm and S and T brakes.	㊳ MODE GUIDE PLATE	Holding cover of the various gears, holds the plunger in position.
㉕ IDLER ARM	Moves left or right in accordance with mode condition, transmits movement of counter gear to S and T reels.	㊴ BRAKE PLUNGER	5V, 200mA, switches brakes on and off in accordance with the mode.

## • REMOVAL OF THE UPPER CYLINDER

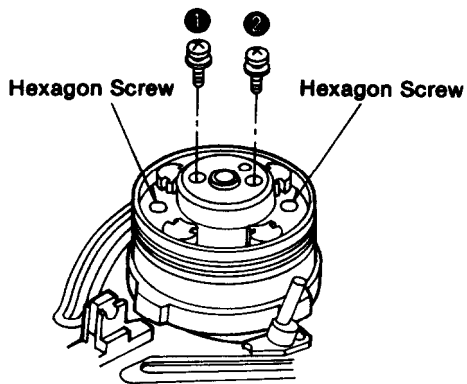

1. Remove the 2 screws (❶, ❷).

**Caution:** Please do not touch Hexagon screws.

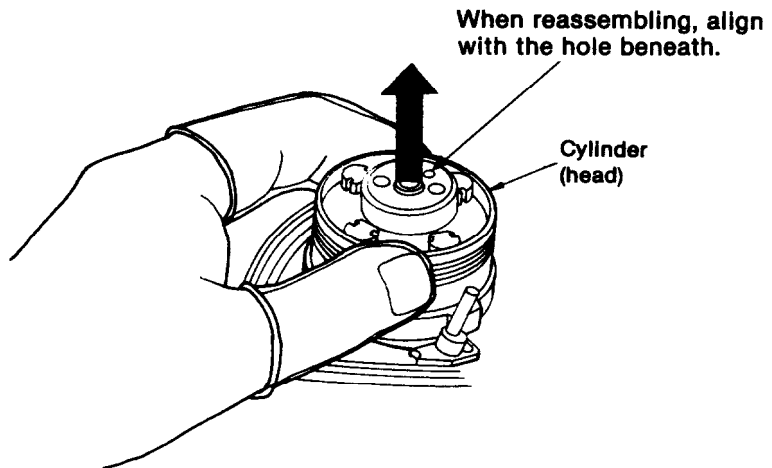

2. Remove the cylinder (head) in the direction of the arrow.

**Note:** Do not touch the cylinder (head) with your bare hand; always be sure to wear a glove or other protection.

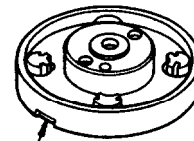

Be sure not to touch the head part.

\* When reassembling the cylinder (head), be sure that the direction is correct. (If it is assembled in the wrong direction, the left and right channels will be reversed during recording and playback.)

• MECHANISM COMPONENT LAYOUT

• Top view

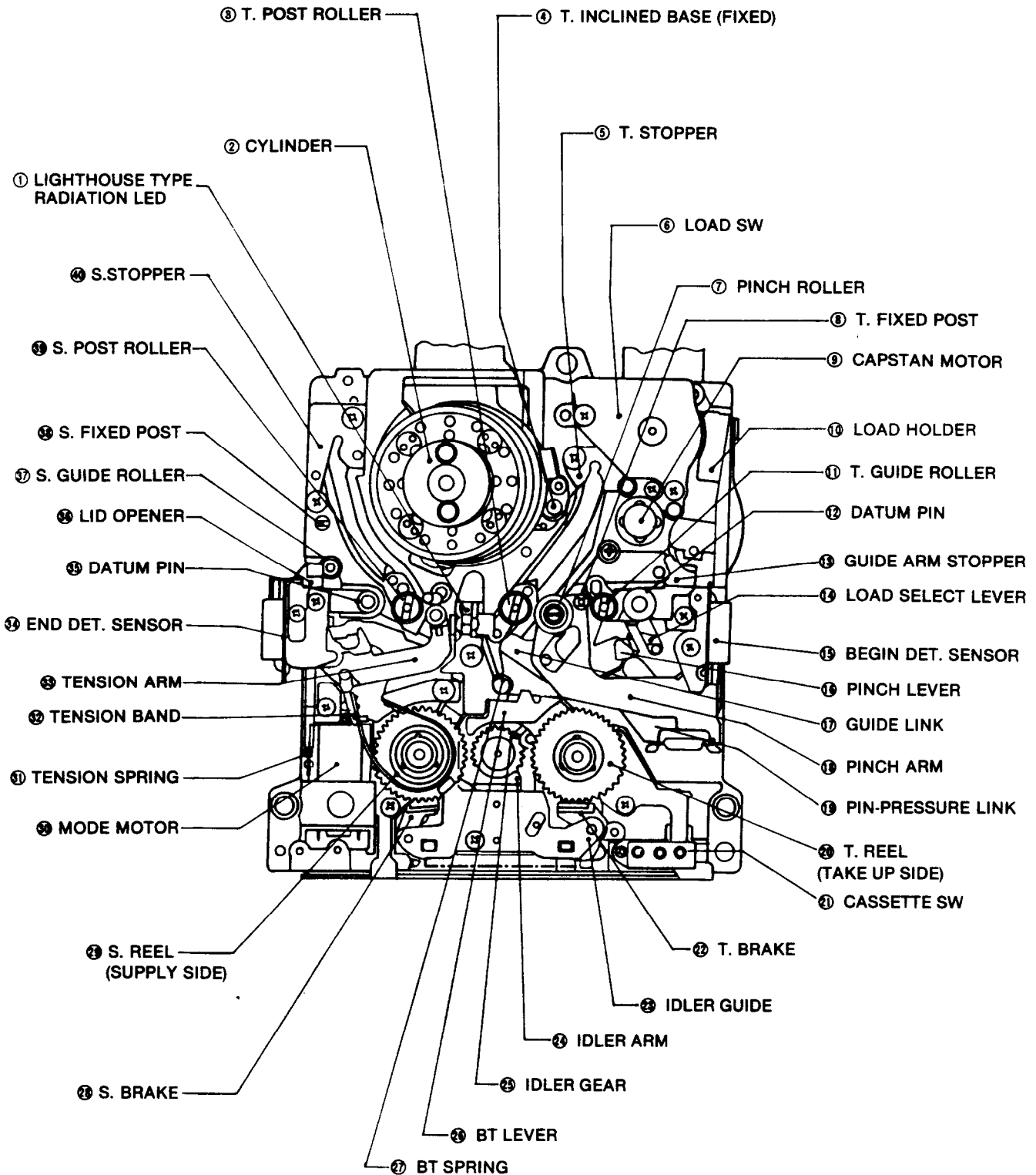

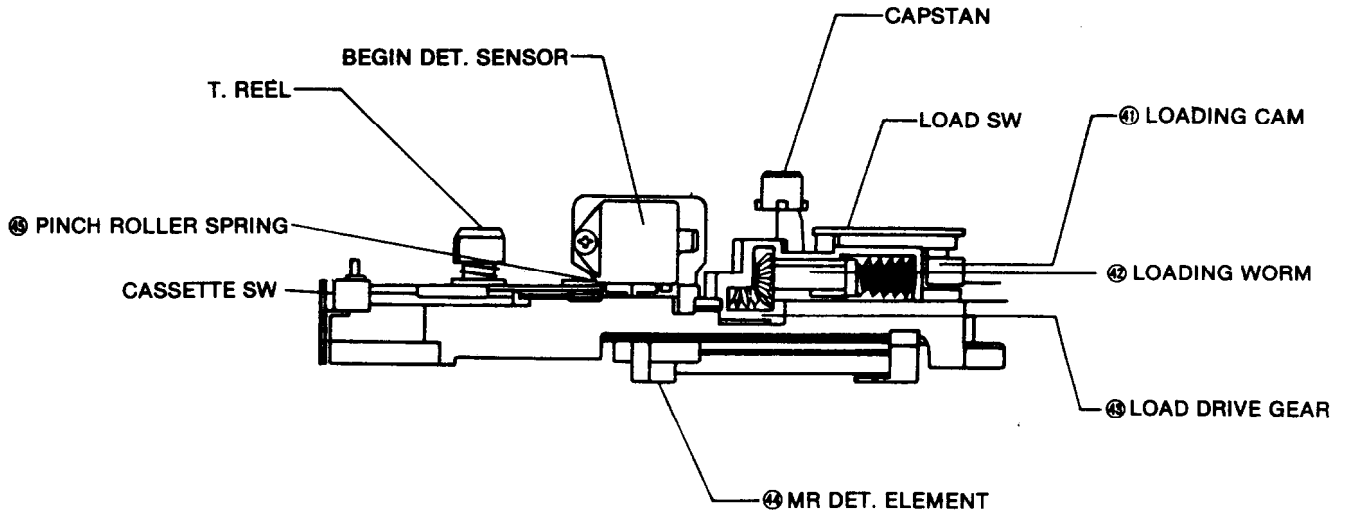

• Side view



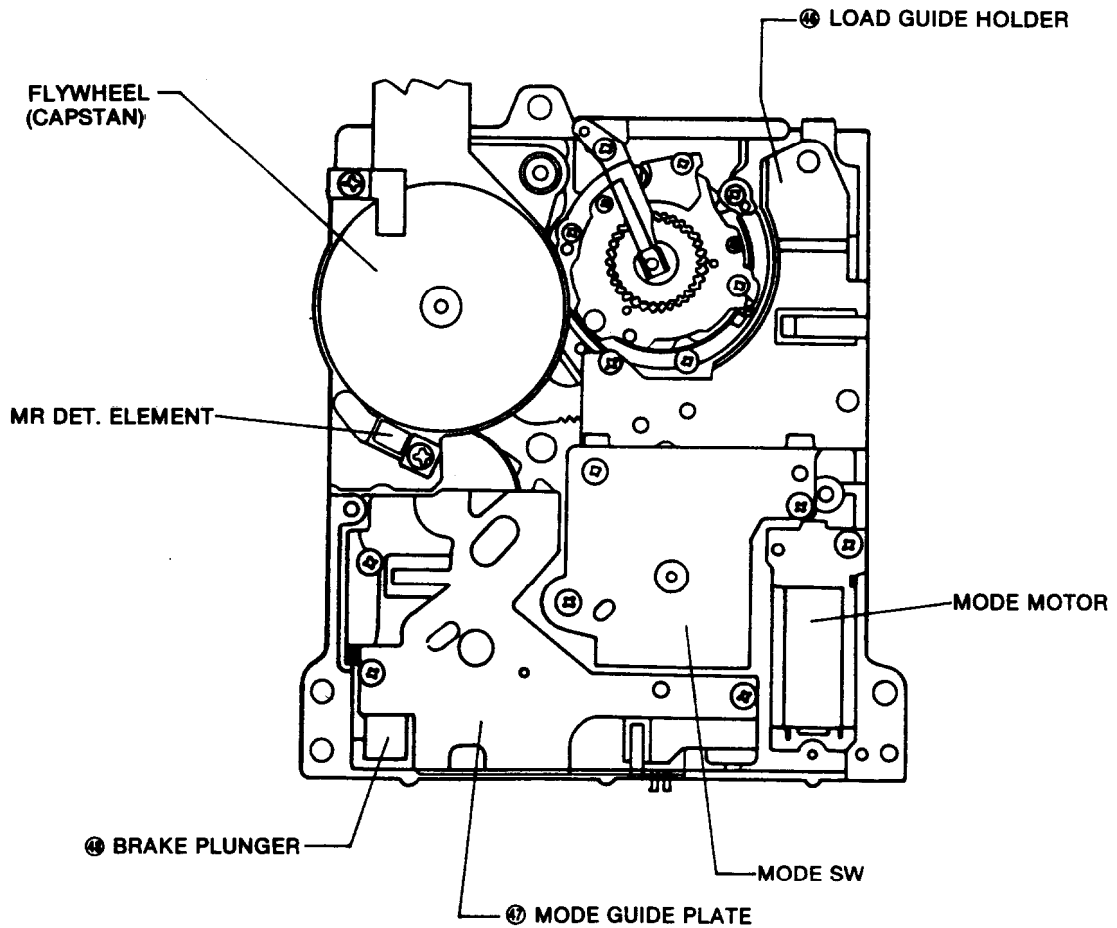

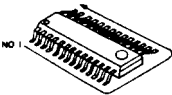
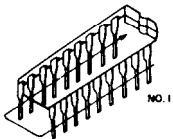
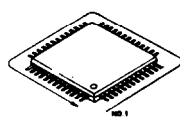
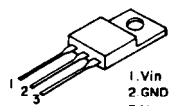
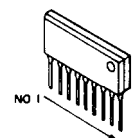
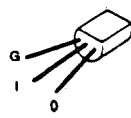
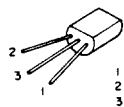
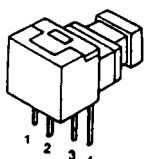
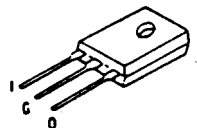
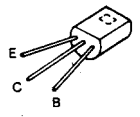
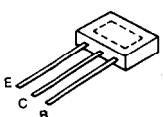
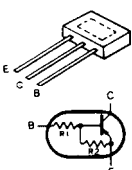
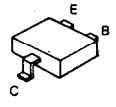
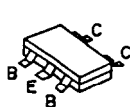
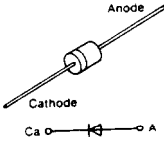
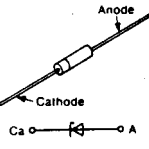
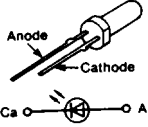

• Bottom view

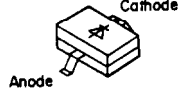
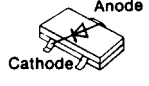
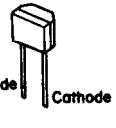

# TERMINAL GUIDE OF IC'S, TRANSISTORS AND DIODES

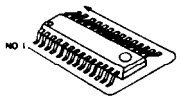
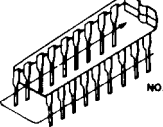
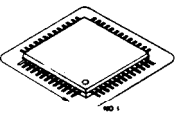
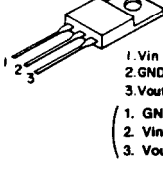
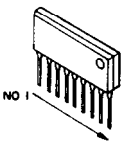
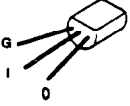
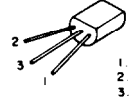
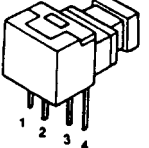
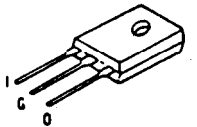
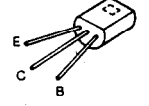
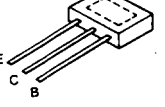
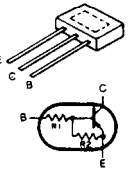
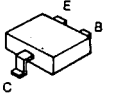
		<table border="1"> <tr> <td>TC4S81FTX</td> <td>5 pin</td> <td>AN6607NSE2</td> <td>16 pin</td> </tr> <tr> <td>AN1339SE2</td> <td rowspan="6">14 pin</td> <td>MN74HC253S</td> <td>18 pin</td> </tr> <tr> <td>MN74HC04S</td> <td>AN6873S</td> <td>28 pin</td> </tr> <tr> <td>MN74HC04SE2</td> <td>SRM20256LM10</td> <td>32 pin</td> </tr> <tr> <td>M5228FPE2</td> <td>AN7035SCE2</td> <td>42 pin</td> </tr> <tr> <td>MN74HCU04S</td> <td>MN6460</td> <td></td> </tr> <tr> <td>MN4066BS-T2</td> <td>AN7030SE2</td> <td></td> </tr> <tr> <td>MN74HC00S</td> <td></td> <td></td> <td></td> </tr> <tr> <td>AN3841SR</td> <td>24 pin</td> <td></td> <td></td> </tr> </table>	TC4S81FTX	5 pin	AN6607NSE2	16 pin	AN1339SE2	14 pin	MN74HC253S	18 pin	MN74HC04S	AN6873S	28 pin	MN74HC04SE2	SRM20256LM10	32 pin	M5228FPE2	AN7035SCE2	42 pin	MN74HCU04S	MN6460		MN4066BS-T2	AN7030SE2		MN74HC00S				AN3841SR	24 pin		
TC4S81FTX	5 pin	AN6607NSE2	16 pin																														
AN1339SE2	14 pin	MN74HC253S	18 pin																														
MN74HC04S		AN6873S	28 pin																														
MN74HC04SE2		SRM20256LM10	32 pin																														
M5228FPE2		AN7035SCE2	42 pin																														
MN74HCU04S		MN6460																															
MN4066BS-T2		AN7030SE2																															
MN74HC00S																																	
AN3841SR	24 pin																																
	<table border="1"> <tr> <td>TC74HCU04AP</td> <td>14 pin</td> </tr> <tr> <td>MN188161SDS4</td> <td>64 pin</td> </tr> </table>	TC74HCU04AP	14 pin	MN188161SDS4	64 pin		<table border="1"> <tr> <td>MN6470</td> <td>42 pin</td> </tr> <tr> <td>AN8320NFA</td> <td>48 pin</td> </tr> <tr> <td>MN6742SDR</td> <td>64 pin</td> </tr> <tr> <td>MN17541SDN2</td> <td>72 pin</td> </tr> <tr> <td>M50754-165FP</td> <td>44 pin</td> </tr> <tr> <td>MN53020SDQ</td> <td>124 pin</td> </tr> <tr> <td>MN6624</td> <td></td> </tr> </table>	MN6470	42 pin	AN8320NFA	48 pin	MN6742SDR	64 pin	MN17541SDN2	72 pin	M50754-165FP	44 pin	MN53020SDQ	124 pin	MN6624													
TC74HCU04AP	14 pin																																
MN188161SDS4	64 pin																																
MN6470	42 pin																																
AN8320NFA	48 pin																																
MN6742SDR	64 pin																																
MN17541SDN2	72 pin																																
M50754-165FP	44 pin																																
MN53020SDQ	124 pin																																
MN6624																																	
 <p>1. Vin 2. GND 3. Vout</p> <p>(1. GND 2. Vin 3. Vout)</p>	<table border="1"> <tr> <td>AN7812F</td> <td rowspan="5">3 pin</td> </tr> <tr> <td>AN7805F</td> </tr> <tr> <td>(AN79M20F)</td> </tr> <tr> <td>M5F78M12L723</td> </tr> <tr> <td>(M5F79M12L723)</td> </tr> </table>	AN7812F	3 pin	AN7805F	(AN79M20F)	M5F78M12L723	(M5F79M12L723)		<table border="1"> <tr> <td>M5218AL</td> <td rowspan="4">8 pin</td> </tr> <tr> <td>M5219L</td> </tr> <tr> <td>M5220L</td> </tr> <tr> <td>M5238L</td> </tr> <tr> <td>TA7291S</td> <td>9 pin</td> </tr> </table>	M5218AL	8 pin	M5219L	M5220L	M5238L	TA7291S	9 pin																	
AN7812F	3 pin																																
AN7805F																																	
(AN79M20F)																																	
M5F78M12L723																																	
(M5F79M12L723)																																	
M5218AL	8 pin																																
M5219L																																	
M5220L																																	
M5238L																																	
TA7291S	9 pin																																
<p>AN79L20</p> 	<p>MN1281R-TA</p>  <p>1. Input 2. Output 3. Common</p>	<p>TORX174-A TOTX174-A</p> 	<p>AN78N05</p> 	<p>2SC1047DTA</p> 																													
	<p>2SA1309STA 2SA1309QRSTA 2SC3311QRSTA 2SC3315CTA 2SD1450RSTTA</p>		<p>UN4124TA UN4112TA UN4111TA</p>		<p>DTB113ZKTW DTA114EKTW 2SB709RTW 2SC3937TW UN5216TW DTA123JKTW DTC124EKTW</p>																												
<p>XN1112TW XN1212TW</p> 	<p>Anode</p>  <p>Cathode</p> <p>Ca — &gt;— A</p>	<p>1SR35200TB MA165TA SVDS2V20 1N4606TR 1S2473TR</p>	<p>MA4051TA MA4033MTA</p>  <p>Anode</p> <p>Cathode</p> <p>Ca — &gt;— A</p>	 <p>Anode</p> <p>Cathode</p> <p>Ca — &gt;— A</p>	<p>LN28RCPJ-JF LN31GPH-JF2 LN49YPH-JF1 LN29RPH-JF1</p>																												
<p>AN78L05ME2</p> 	<p>2SB956RTW 2SD1280STW</p> 	<p>MA701TW</p>  <p>Cathode</p> <p>Anode</p> <p>A — &gt;— Ca</p>	<p>MA151ATW</p>  <p>Anode</p> <p>Cathode</p>	<p>RVDSVC321</p>  <p>Anode</p> <p>Cathode</p> <p>A — &gt;— Ca</p>																													

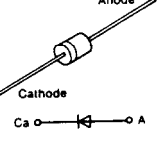
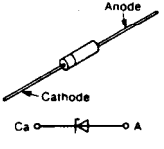
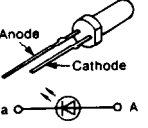
# ■ TERMINAL GUIDE OF IC'S, TRANSISTORS AND DIODES

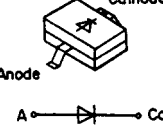
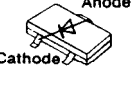
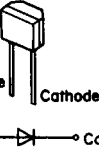
		<table border="1"> <tr> <td>TC4S81FTX</td> <td>5 pin</td> <td>AN6607NSE2 MN74HC253S</td> <td>16 pin</td> </tr> <tr> <td>AN1339SE2 MN74HC04S MN74HC04SE2 M5228FPE2 MN74HCU04S MN4066BS-T2 MN74HC00S</td> <td>14 pin</td> <td>AN6873S</td> <td>18 pin</td> </tr> <tr> <td></td> <td></td> <td>SRM20256LM10</td> <td>28 pin</td> </tr> <tr> <td></td> <td></td> <td>AN7035SCE2</td> <td>32 pin</td> </tr> <tr> <td></td> <td></td> <td>MN6460 AN7030SE2</td> <td>42 pin</td> </tr> <tr> <td>AN3841SR</td> <td>24 pin</td> <td></td> <td></td> </tr> </table>	TC4S81FTX	5 pin	AN6607NSE2 MN74HC253S	16 pin	AN1339SE2 MN74HC04S MN74HC04SE2 M5228FPE2 MN74HCU04S MN4066BS-T2 MN74HC00S	14 pin	AN6873S	18 pin			SRM20256LM10	28 pin			AN7035SCE2	32 pin			MN6460 AN7030SE2	42 pin	AN3841SR	24 pin		
TC4S81FTX	5 pin	AN6607NSE2 MN74HC253S	16 pin																							
AN1339SE2 MN74HC04S MN74HC04SE2 M5228FPE2 MN74HCU04S MN4066BS-T2 MN74HC00S	14 pin	AN6873S	18 pin																							
		SRM20256LM10	28 pin																							
		AN7035SCE2	32 pin																							
		MN6460 AN7030SE2	42 pin																							
AN3841SR	24 pin																									
	<table border="1"> <tr> <td>TC74HCU04AP</td> <td>14 pin</td> </tr> <tr> <td>MN188161SDS4</td> <td>64 pin</td> </tr> </table>	TC74HCU04AP	14 pin	MN188161SDS4	64 pin		<table border="1"> <tr> <td>MN6470</td> <td>42 pin</td> </tr> <tr> <td>AN8320NFA</td> <td>48 pin</td> </tr> <tr> <td>MN6742SDR MN17541SDN2</td> <td>64 pin</td> </tr> <tr> <td>M50754-165FP</td> <td>72 pin</td> </tr> <tr> <td>MN53020SDQ</td> <td>44 pin</td> </tr> <tr> <td>MN6624</td> <td>124 pin</td> </tr> </table>	MN6470	42 pin	AN8320NFA	48 pin	MN6742SDR MN17541SDN2	64 pin	M50754-165FP	72 pin	MN53020SDQ	44 pin	MN6624	124 pin							
TC74HCU04AP	14 pin																									
MN188161SDS4	64 pin																									
MN6470	42 pin																									
AN8320NFA	48 pin																									
MN6742SDR MN17541SDN2	64 pin																									
M50754-165FP	72 pin																									
MN53020SDQ	44 pin																									
MN6624	124 pin																									
 <p>1. Vin 2. GND 3. Vout  1. GND 2. Vin 3. Vout</p>	<table border="1"> <tr> <td>AN7812F AN7805F (AN79M20F) M5F78M12L723 (M5F79M12L723)</td> <td>3 pin</td> </tr> </table>	AN7812F AN7805F (AN79M20F) M5F78M12L723 (M5F79M12L723)	3 pin		<table border="1"> <tr> <td>M5218AL M5219L M5220L M5238L</td> <td>8 pin</td> </tr> <tr> <td>TA7291S</td> <td>9 pin</td> </tr> </table>	M5218AL M5219L M5220L M5238L	8 pin	TA7291S	9 pin																	
AN7812F AN7805F (AN79M20F) M5F78M12L723 (M5F79M12L723)	3 pin																									
M5218AL M5219L M5220L M5238L	8 pin																									
TA7291S	9 pin																									
<p>AN79L20</p>  <p>G I O</p>	<p>MN1281R-TA</p>  <p>1 Input 2 Output 3 Common</p>	<p>TORX174-A TOTX174-A</p>  <p>1 2 3 4</p>	<p>AN78N05</p>  <p>I G O</p>	<p>2SC1047DTA</p>  <p>E C B</p>																						
	<p>2SA1309STA 2SA1309QRSTA 2SC3311QRSTA 2SC3315CTA 2SD1450RSTTA</p>		<p>UN4124TA UN4112TA UN4111TA</p>		<p>DTB113ZKTW DTA114EKTW 2SB709RTW 2SC3937TW UN5216TW DTA123JKTW DTC124EKTW</p>																					
<p>XN1112TW XN1212TW</p> 	 <p>Anode Cathode Ca → A</p>	<p>1SR35200TB MA165TA SVDS2V20 1N4606TR 1S2473TR</p>	 <p>Anode Cathode Ca → A</p>	 <p>Anode Cathode Ca → A</p>	<p>LN28RCPJ-JF LN31GPH-JF2 LN49YPH-JF1 LN29RPH-JF1</p>																					
<p>AN78L05ME2</p> 	<p>2SB956RTW 2SD1280STW</p> 	<p>MA701TW</p>  <p>Cathode Anode A → Ca</p>	<p>MA151ATW</p>  <p>Anode Cathode</p>	<p>RVDSVC321</p>  <p>Anode Cathode A → Ca</p>																						

# SCHEMATIC DIAGRAM

(This schematic diagram may be modified at any time with development of new technology.)

### Note 1:

- S701 : Tape hole detection switch.
- Resistance are in ohms ( $\Omega$ ), 1/4 watt unless specified otherwise.
- $1K=1,000 (\Omega)$ ,  $1M=1,000k (\Omega)$
- Capacity are in micro-farads ( $\mu F$ ) unless specified otherwise.
- All voltage values shown in circuitry are under no signal condition and playback mode with volume control at minimum position otherwise specified.
- ( ) ..... Voltage values at recording mode.
- For measurement us EVM.
- Important safety notice  
Components identified by  $\Delta$  mark have special characteristics important for safety. When replacing any of these components, use only manufacturer's specified parts.

Part No.	Original Part No.	Supply Part No.
IC551, 552	M5218AL	M5218L

- ( ) indicates + B (bias).
- ( ) indicates - B (bias).
- ( ) indicates the flow of the playback signal.
- ( ) indicates the flow of the recording signal.

### \* Caution !

- IC and LSI are sensitive to static electricity. Secondary trouble can be prevented by taking care during repair.
- \* Cover the parts boxes made of plastics with aluminum foil.
- \* Ground the soldering iron.
- \* Put a conductive mat on the work table.
- \* Do not touch the legs of IC or LSI with the fingers directly.

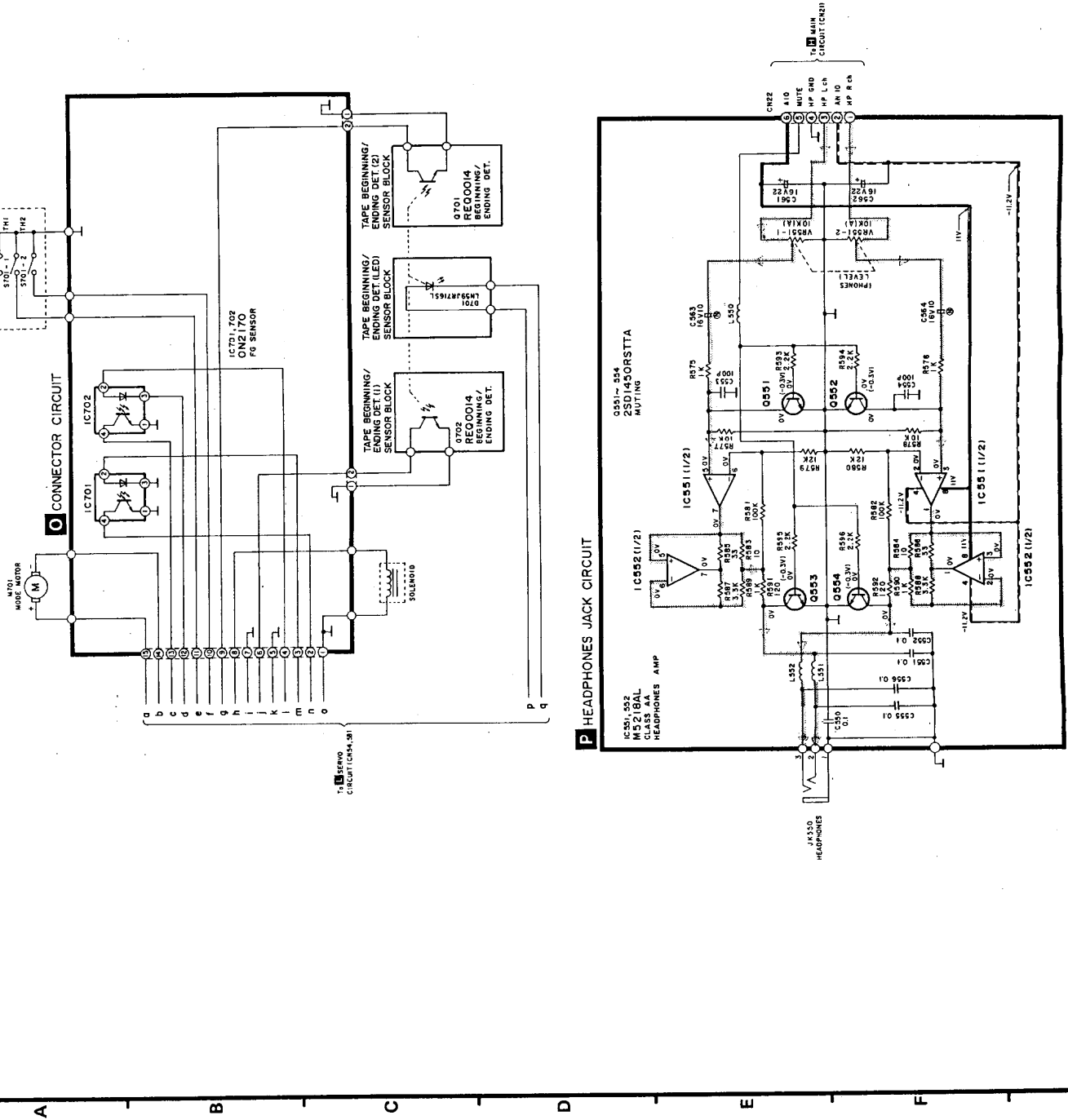

P HEADPHONES JACK CIRCUIT

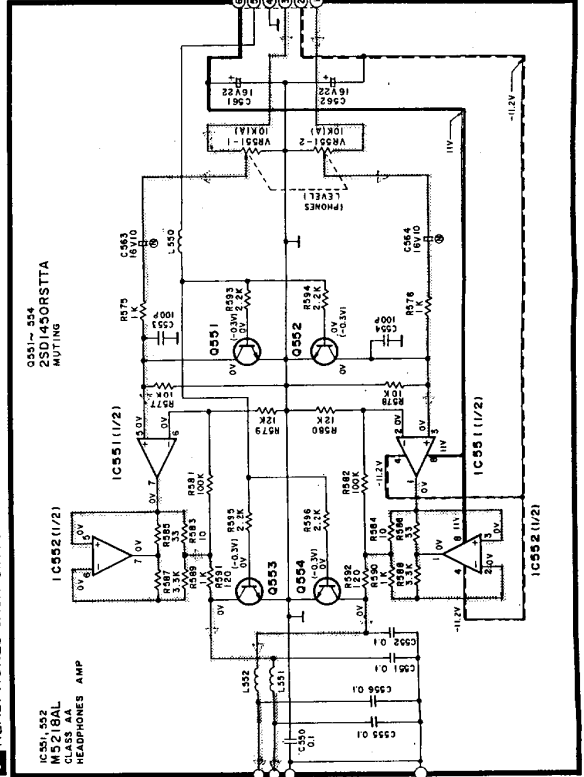

**K RF CIRCUIT**

**Note 3:**

- All voltage values shown in circuitry are under no signal condition and playback mode with volume control at minimum position otherwise specified.
- ( ) ..... Voltage values at recording mode.
- For measurement us EVM.
- Important safety notice
- Components identified by  $\Delta$  mark have special characteristics important for safety. When replacing any of these components, use only manufacturer's specified parts.
- ( ) indicates + B (bias).
- ( ) indicates - B (bias).
- ( ) indicates the flow of the playback signal.
- ( ) indicates the flow of the recording signal.

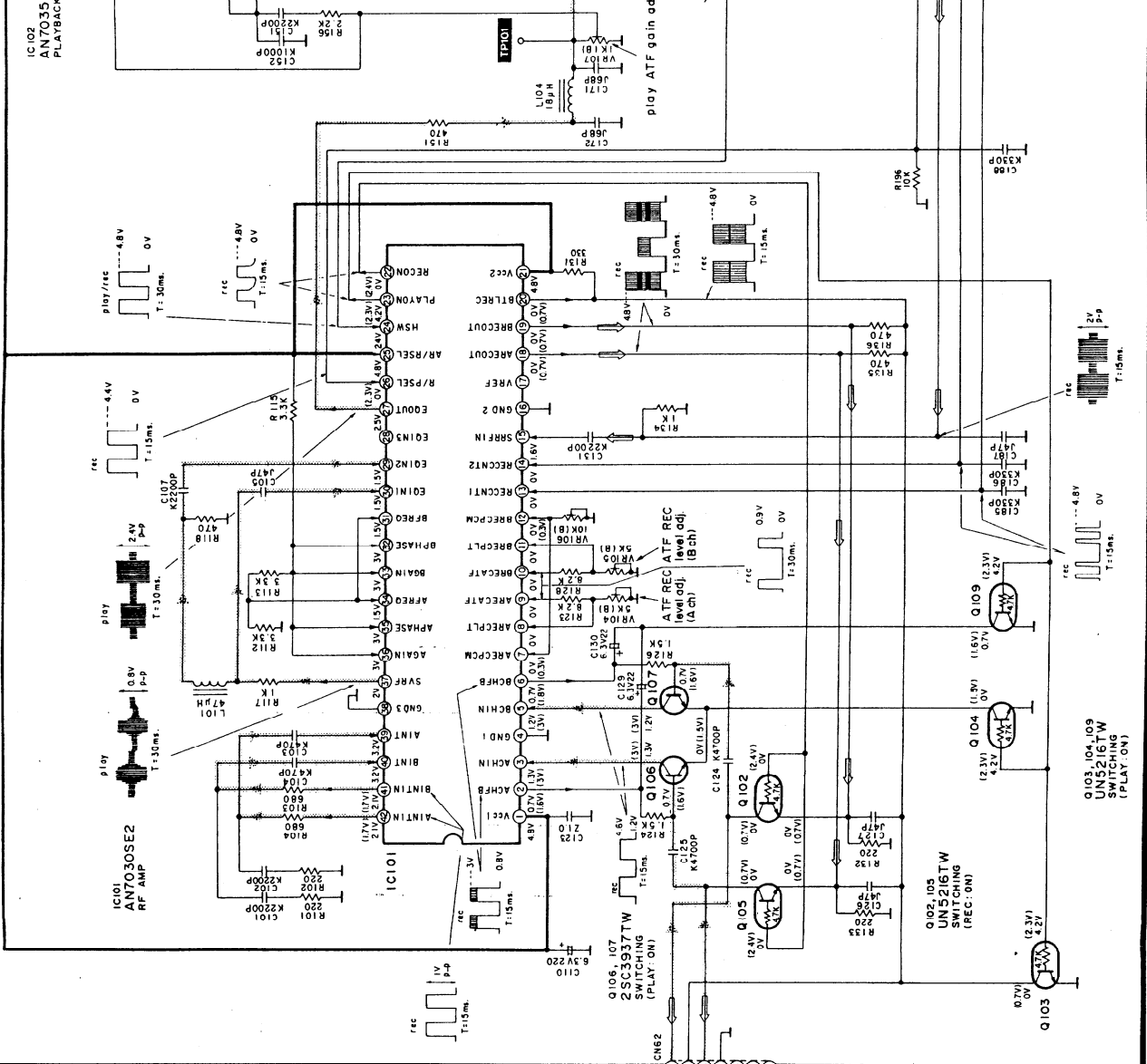

Q103, Q104, Q109  
UN5216TW  
SWITCHING  
(PLAY: ON)

Q102, Q105  
UN5216TW  
SWITCHING  
(REC: ON)

Q106, Q107  
2SC3037TW  
SWITCHING  
(PLAY: ON)

Q108, Q109  
ATF REC ATF REC  
level adj.  
(A ch)

Q110  
play ATF gain ad

IC102  
AN7035  
PLAYBACK

IC101  
AN7030SE2  
RF AMP

B. HEAD  
A. HEAD



K RF CIRCUIT

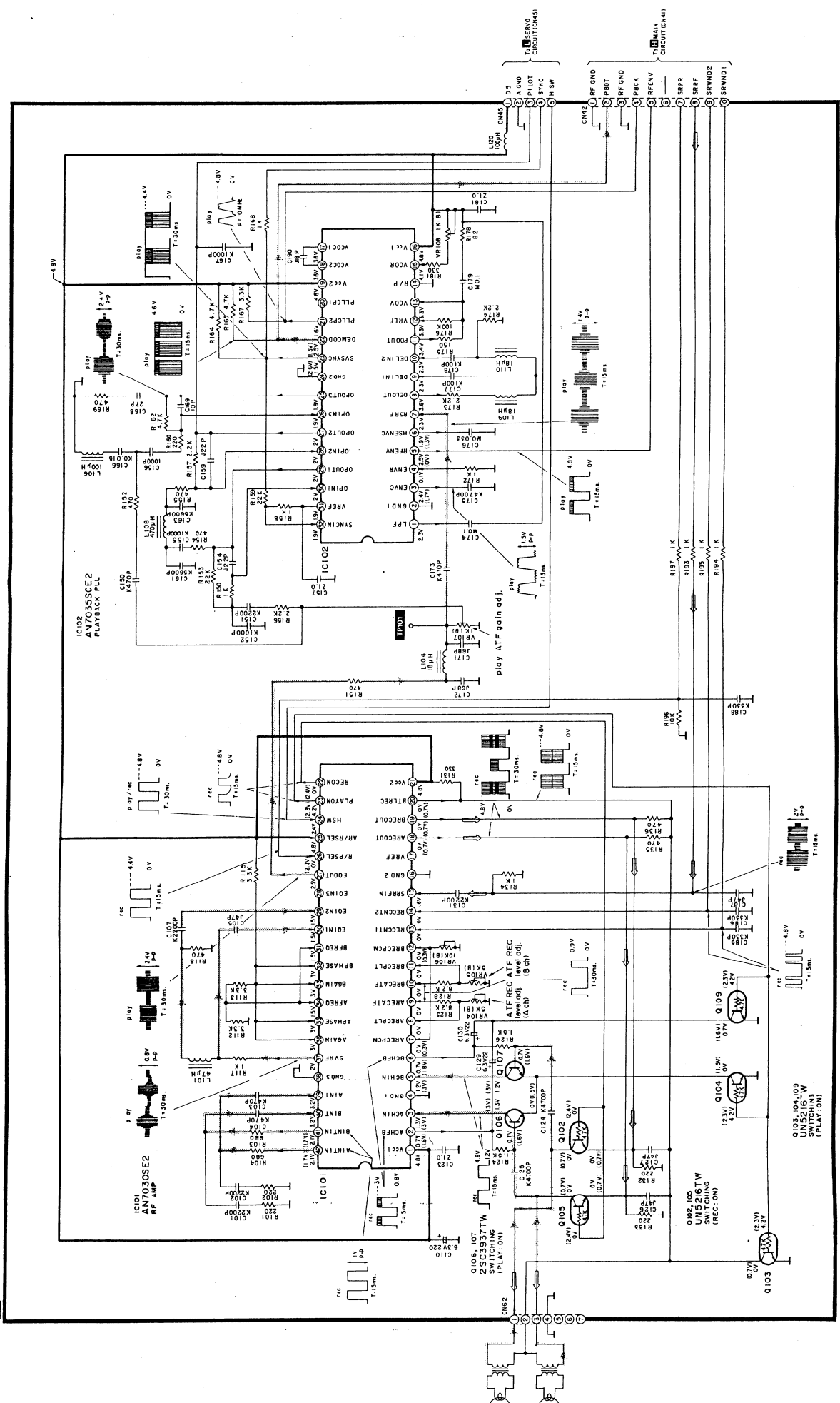

**SERVO CIRCUIT**

**Note 2:**

- S702 : Loading detection switch.
- S703 : Mode detection switch.
- S751 : Cassette tray open detection switch.
- S752 : Cassette tray close detection switch.
- All voltage values shown in circuitry are under no signal condition and playback mode with volume control at minimum position otherwise specified.
- ( ) ..... Voltage values at recording mode.
- For measurement us EVM.
- Important safety notice

Components identified by  $\Delta$  mark have special characteristics important for safety. When replacing any of these components, use only manufacturer's specified parts.

- ( ) indicates +B (bias).
- ( ) indicates -B (bias).
- ( ) indicates the flow of the playback signal.
- ( ) indicates the flow of the recording signal.

• The "IC701, IC702, Q701, Q702, D701, MR701, L701~708, CAPH701~703, CYLH701~703" parts are not supplied separately and are thus not found on the replacement parts list.

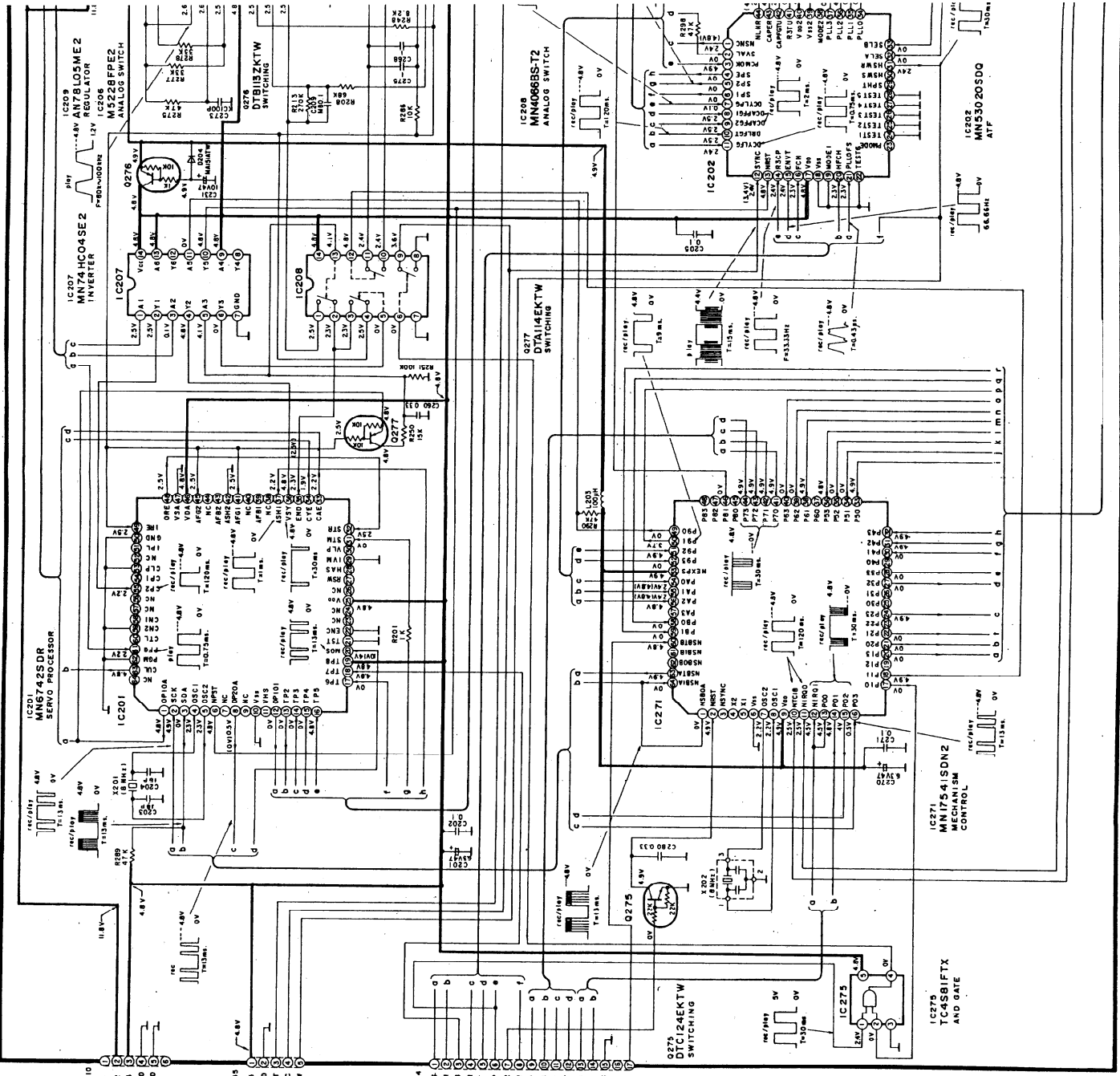



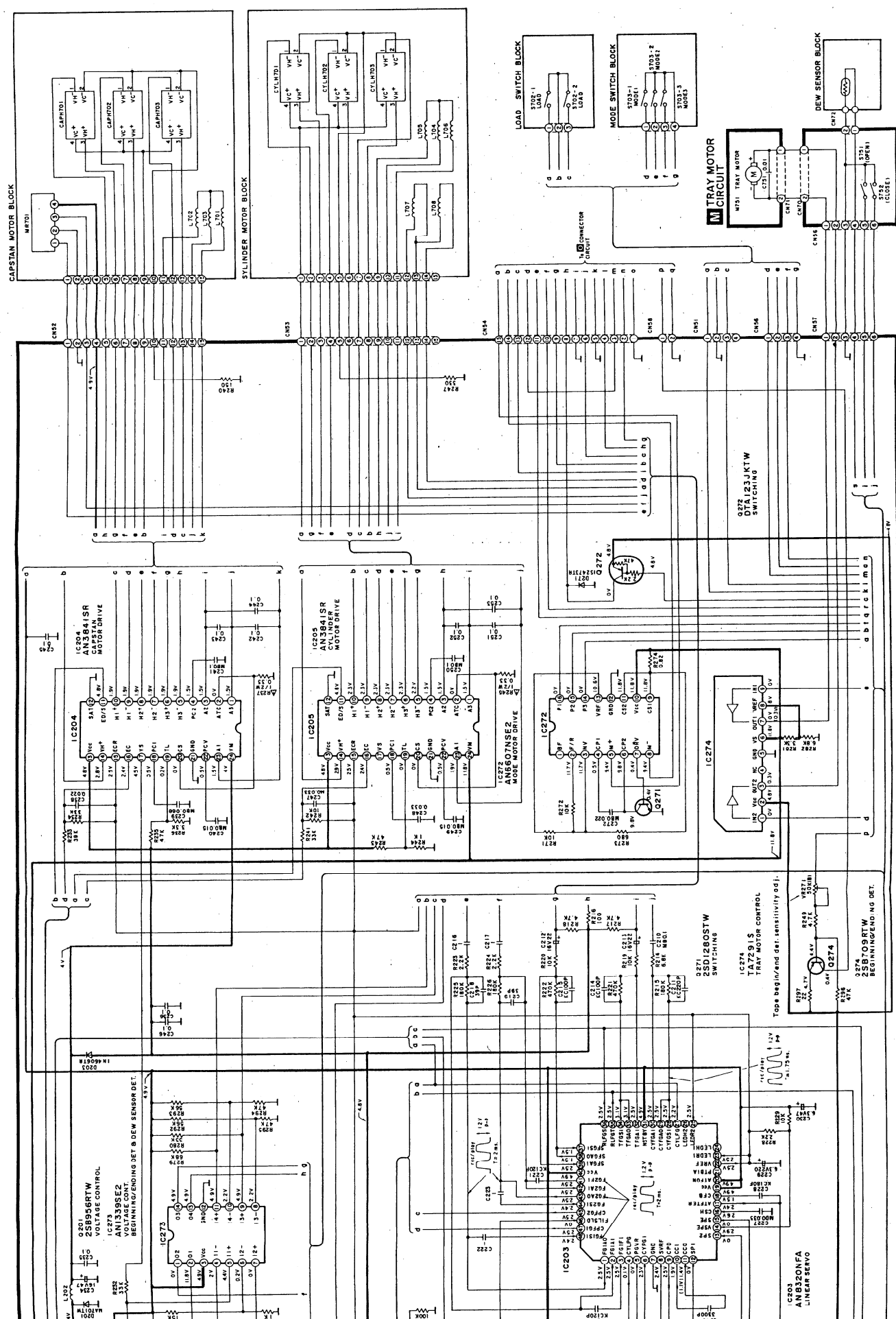



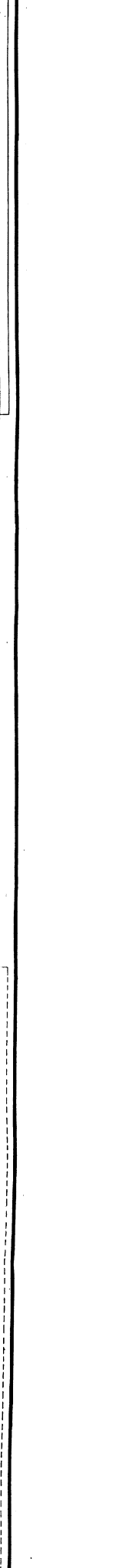
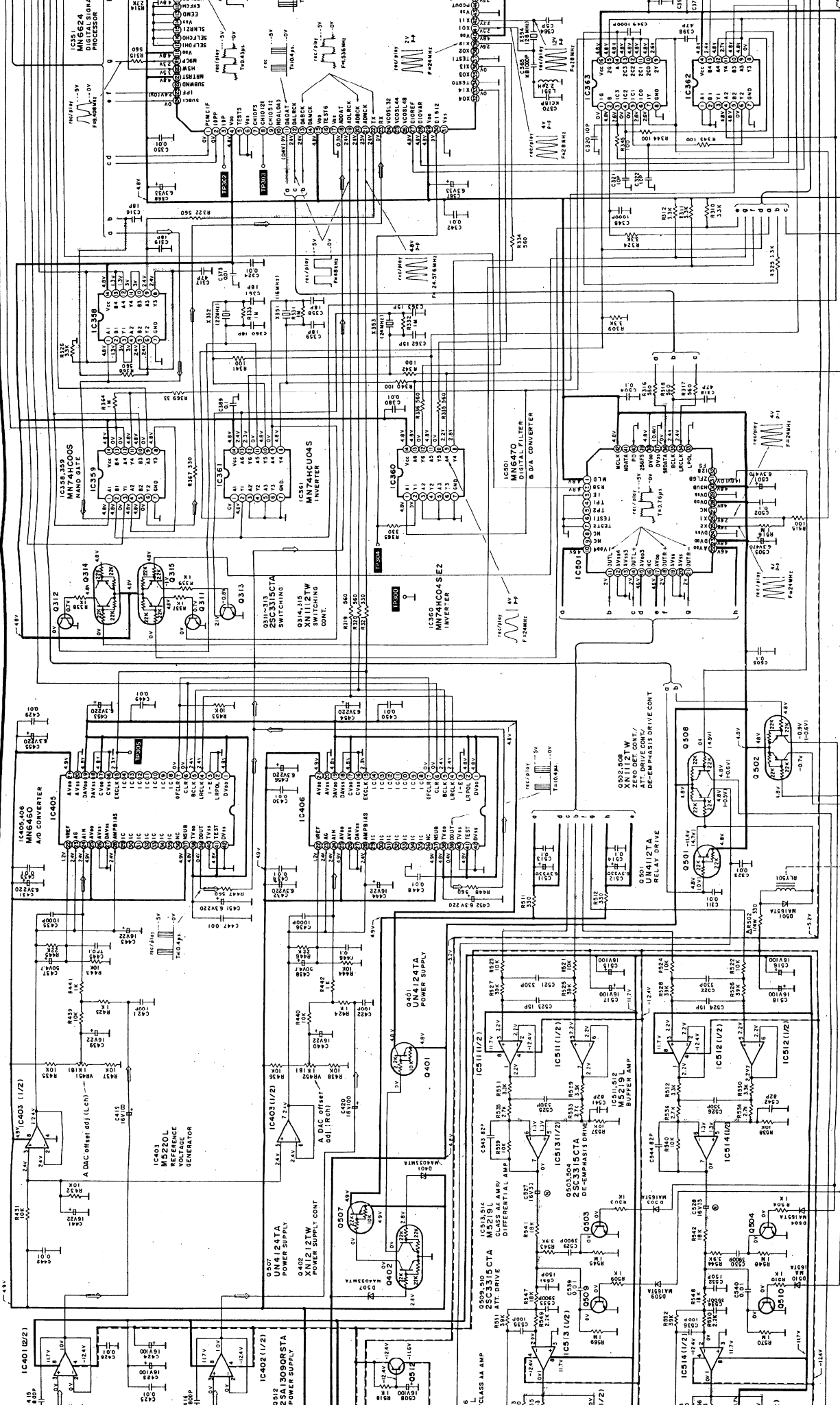

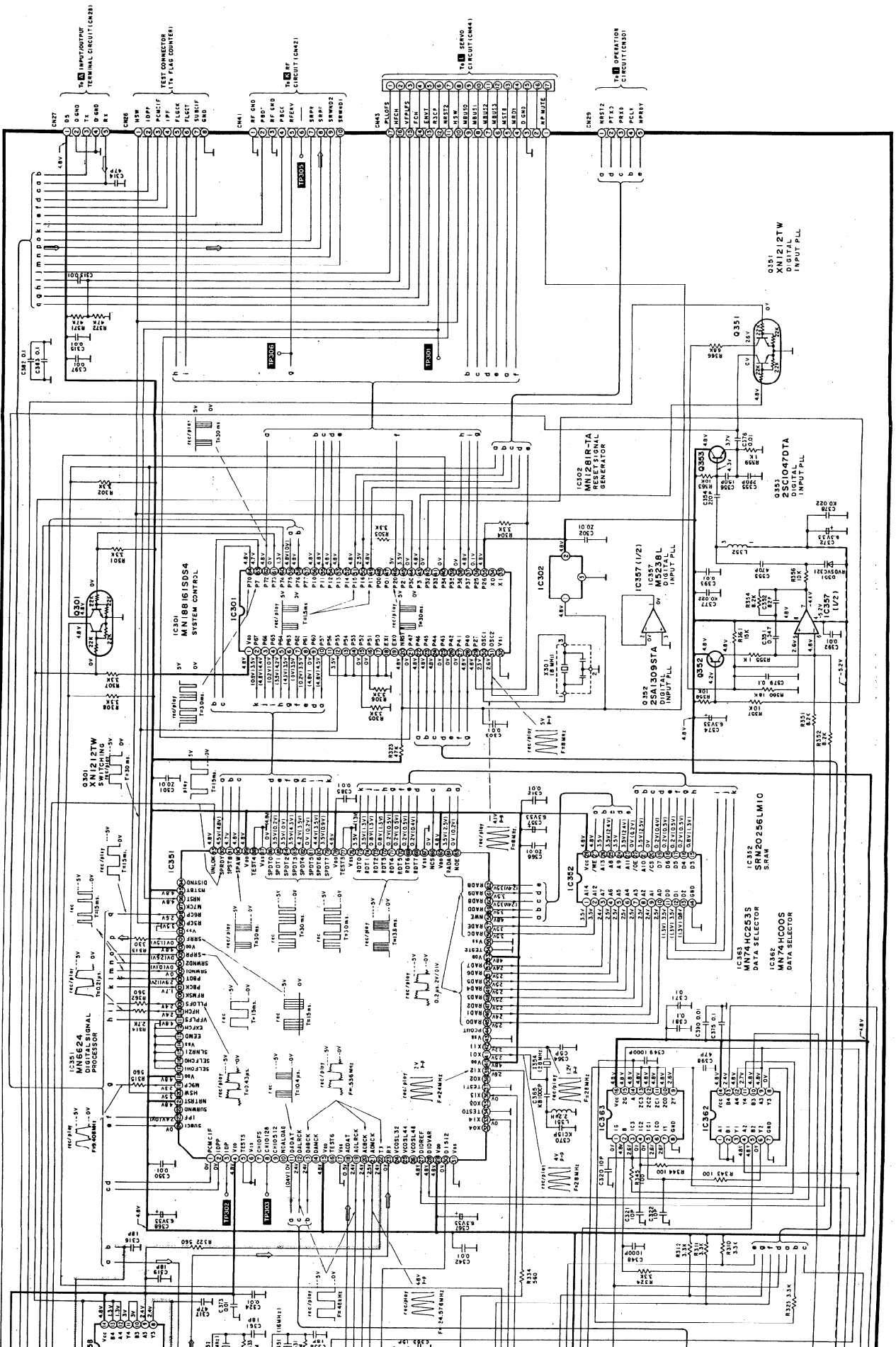

OPERATION CIRCUIT

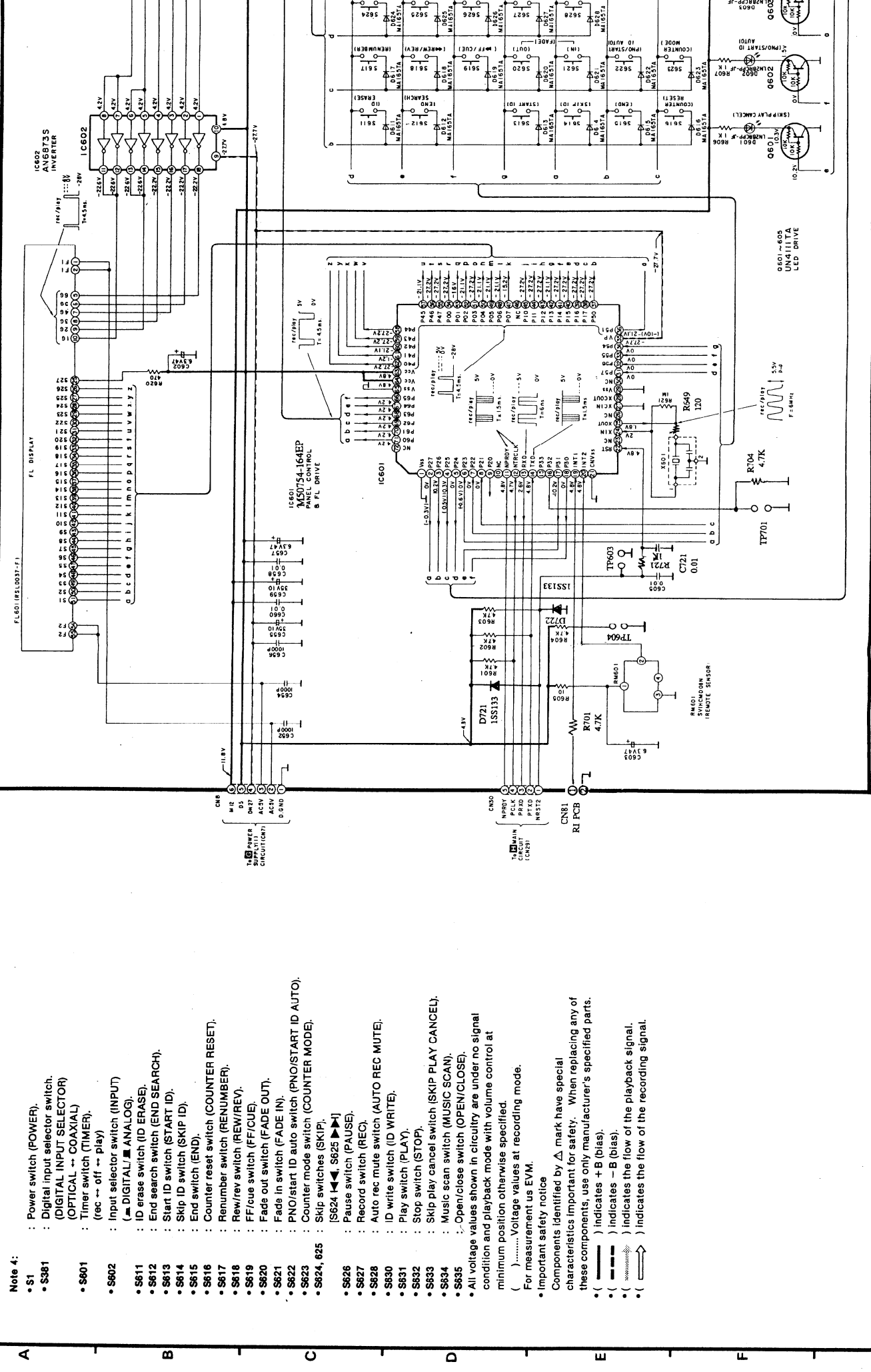

- Note 4:
- S1 : Power switch (POWER).
  - S381 : Digital input selector switch. (DIGITAL INPUT SELECTOR) (OPTICAL ↔ COAXIAL)
  - S601 : Timer switch (TIMER). (rec ↔ off ↔ play)
  - S602 : Input selector switch (INPUT) (DIGITAL/ANALOG).
  - S611 : ID erase switch (ID ERASE).
  - S612 : End search switch (END SEARCH).
  - S613 : Start ID switch (START ID).
  - S614 : Skip ID switch (SKIP ID).
  - S615 : End switch (END).
  - S616 : Counter reset switch (COUNTER RESET).
  - S617 : Renumber switch (RENUMBER).
  - S618 : Rew/rev switch (REW/REV).
  - S619 : FF/cue switch (FF/CUE).
  - S620 : Fade out switch (FADE OUT).
  - S621 : Fade in switch (FADE IN).
  - S622 : PNO/start ID auto switch (PNO/START ID AUTO).
  - S623 : Counter mode switch (COUNTER MODE).
  - S624, 625 : Skip switches (SKIP).
  - S626 : Pause switch (PAUSE).
  - S627 : Record switch (REC).
  - S628 : Auto rec mute switch (AUTO REC MUTE).
  - S630 : ID write switch (ID WRITE).
  - S631 : Play switch (PLAY).
  - S632 : Stop switch (STOP).
  - S633 : Skip play cancel switch (SKIP PLAY CANCEL).
  - S634 : Music scan switch (MUSIC SCAN).
  - S635 : Open/close switch (OPEN/CLOSE).
- All voltage values shown in circuitry are under no signal condition and playback mode with volume control at minimum position otherwise specified.
- ( ) ..... Voltage values at recording mode.  
 For measurement us EVM.  
 • Important safety notice  
 Components identified by Δ mark have special characteristics important for safety. When replacing any of these components, use only manufacturer's specified parts.  
 • ( ) Indicates + B (bias).  
 • ( ) Indicates - B (bias).  
 • ( ) Indicates the flow of the playback signal.  
 • ( ) Indicates the flow of the recording signal.



**I** OPERATION CIRCUIT

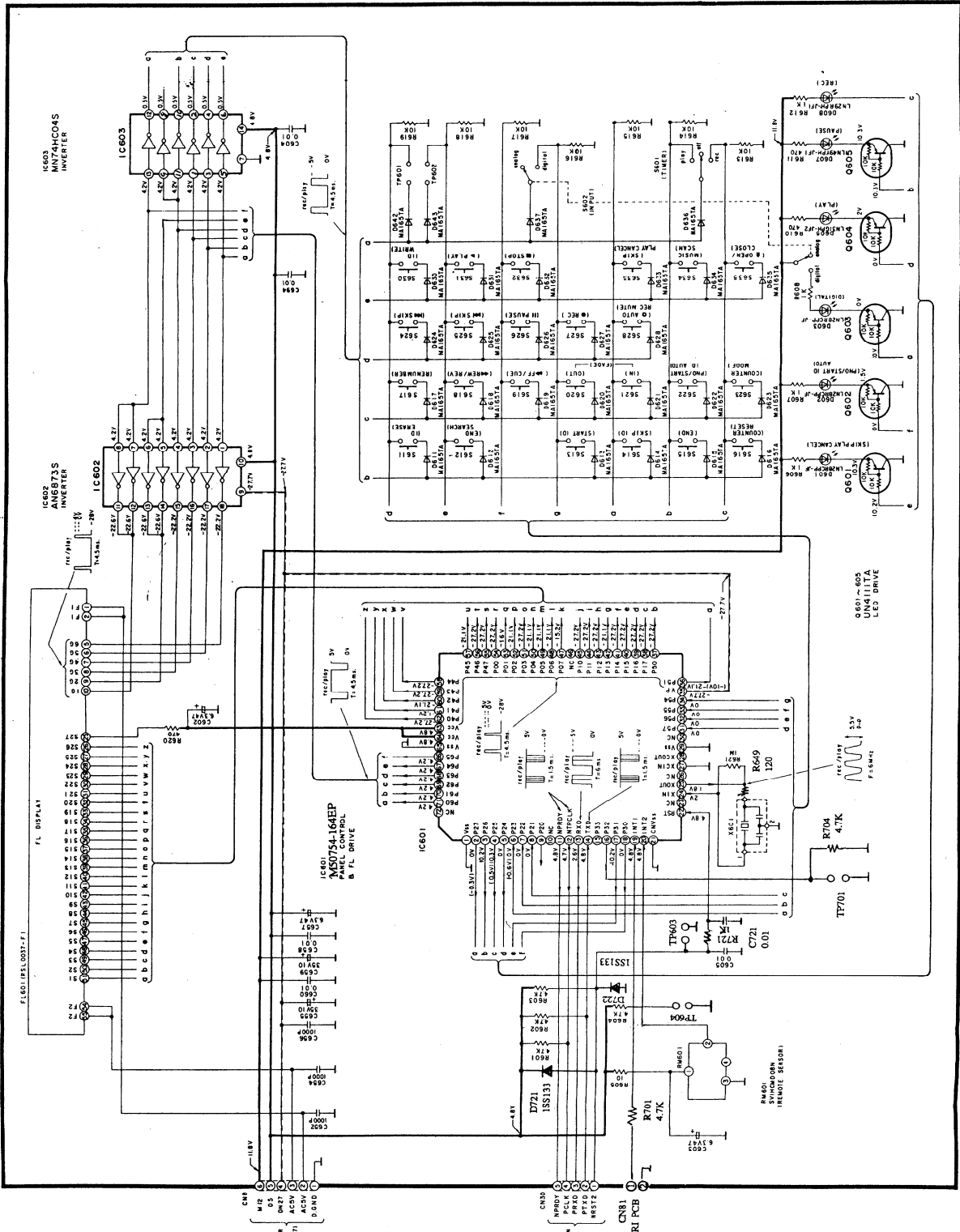

**CAUTION:** FOR CONTINUED PROTECTION AGAINST FIRE HAZARD, REPLACE ONLY WITH SAME TYPE 500mA 125V FUSE.

**RISK OF FIRE-REPLACE FUSE AS MARKED.**



**FUSE CAUTION**

This symbol located near the fuse indicates that the fuse used is fast operating type. For continued protection against fire hazard, replace with same type fuse. For fuse rating, refer to the marking adjacent to the symbol.

Ce symbole indique que le fusible utilisé est à rapide. Pour une protection permanente, n' utiliser que des fusibles de même type. Ce dernier est indiqué là où le présent symbole est apposé.

**J** RI CIRCUIT

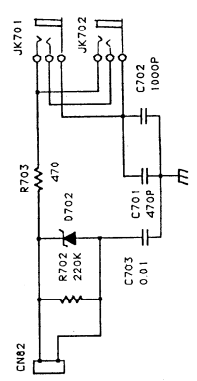

**A INPUT/OUTPUT TERMINAL CIRCUIT**

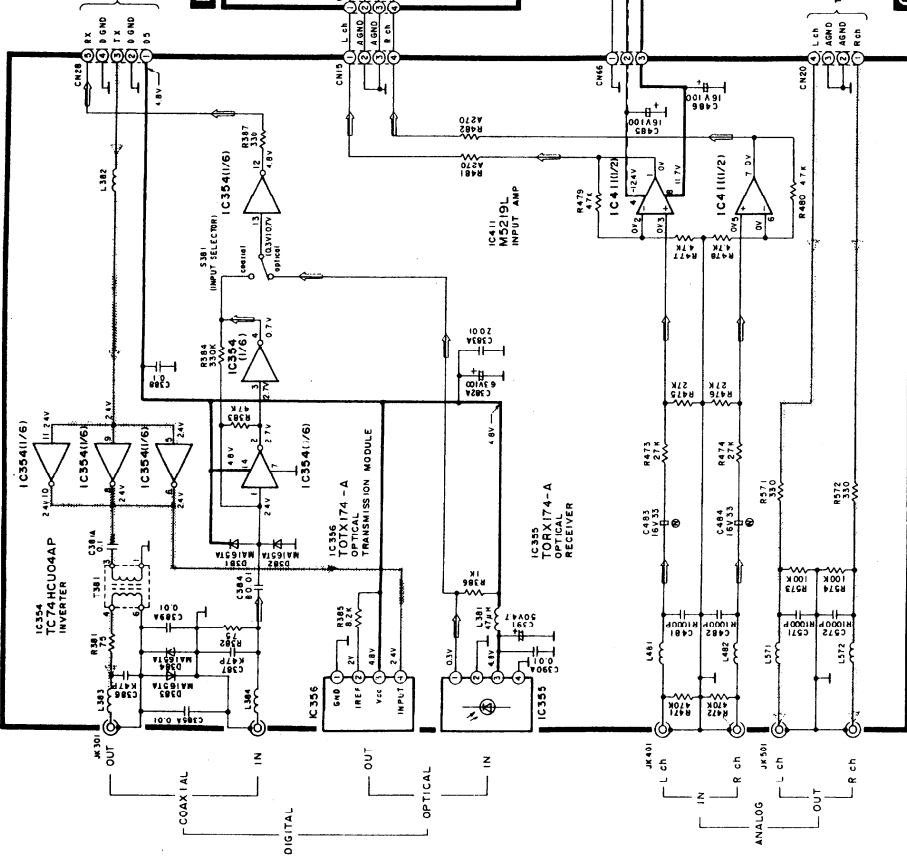

**B BALANCE/REC LEVEL CIRCUIT**

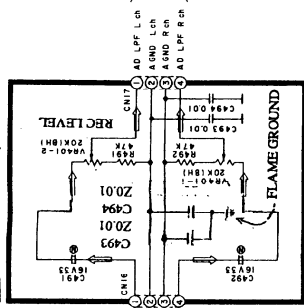

**C POWER SUPPLY (2) CIRCUIT**

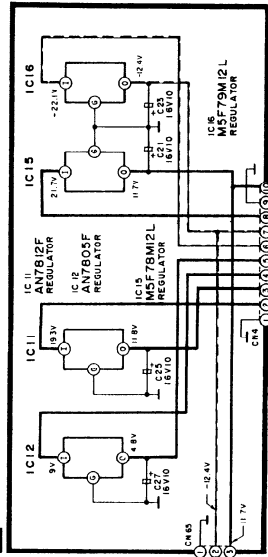

**E POWER TRANSFORMER CIRCUIT**

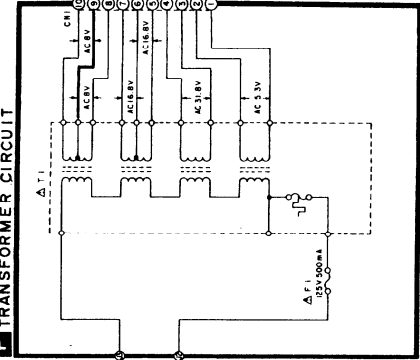

**D AC IN TERMINAL CIRCUIT**

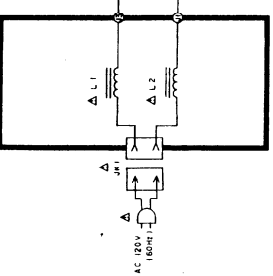

**F POWER SWITCH CIRCUIT**

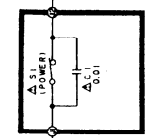

**G POWER SUPPLY (1) CIRCUIT**

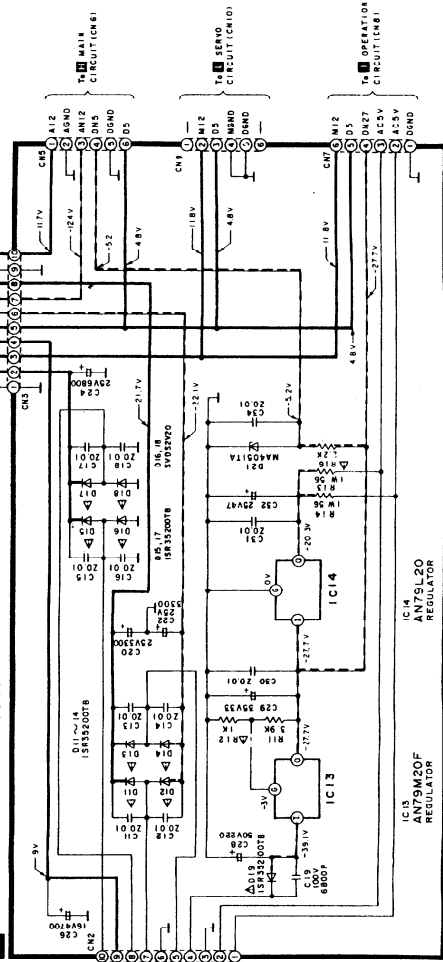

# WIRING CONNECTION DIAGRAM

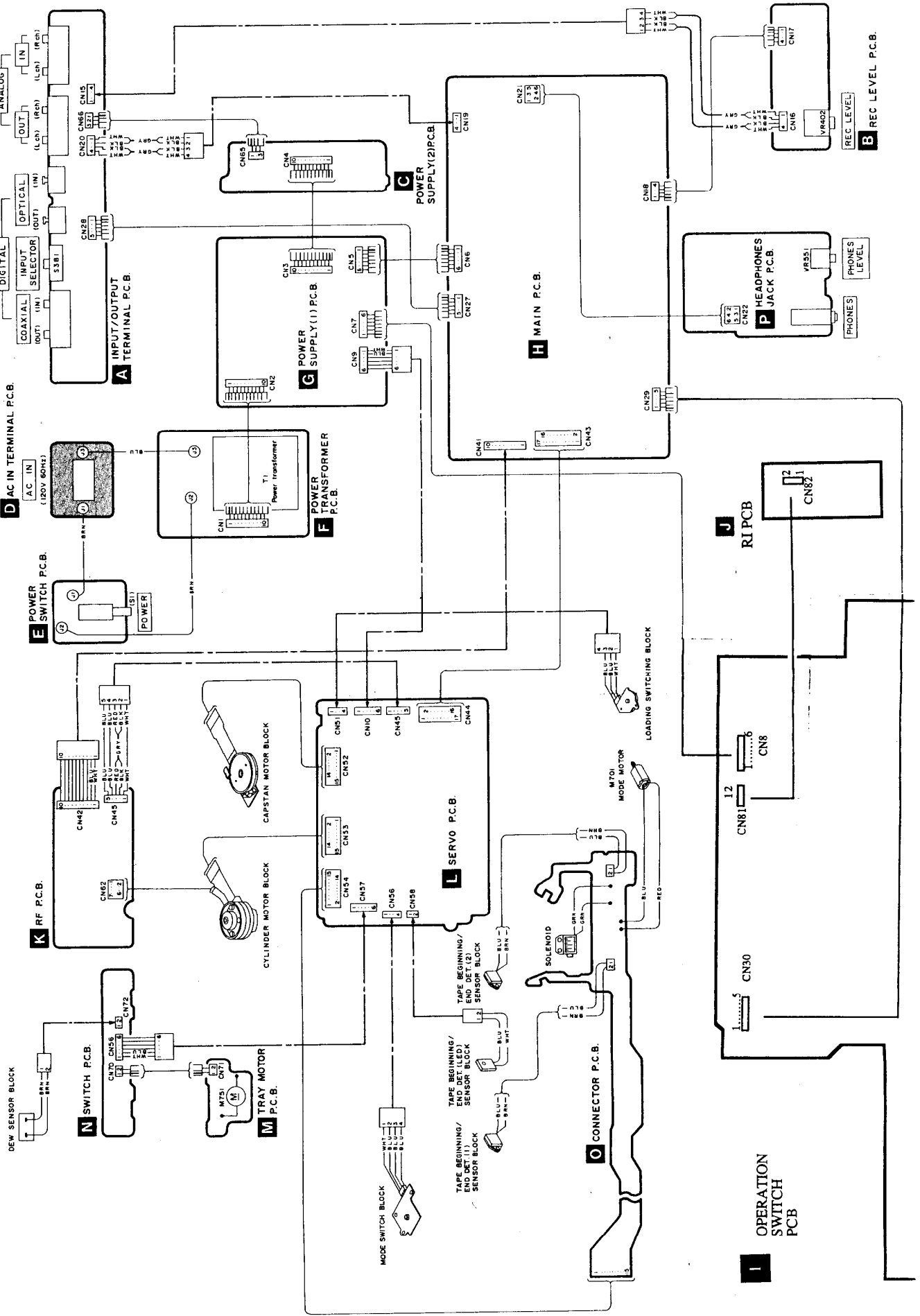

**BLOCK DIAGRAM**

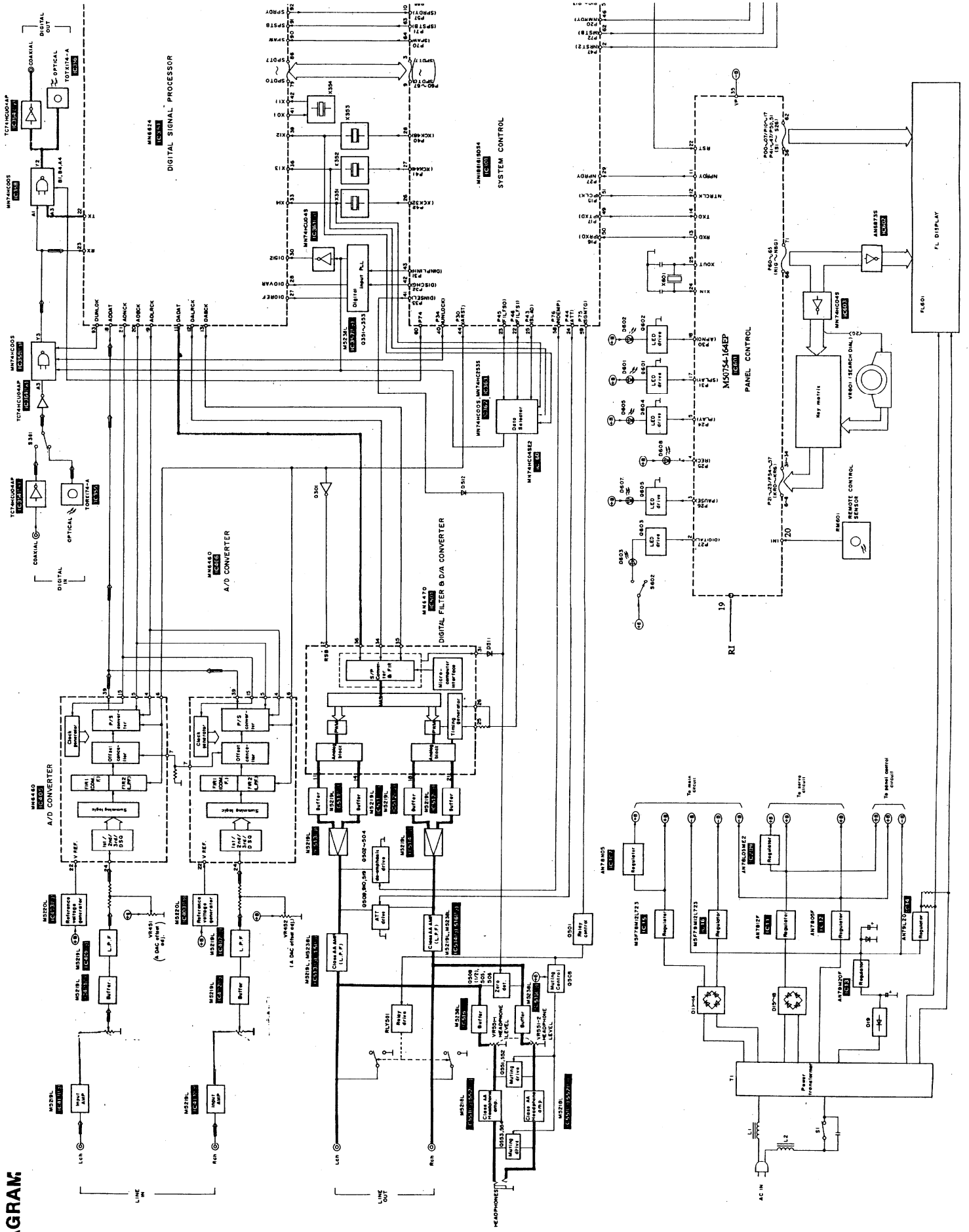

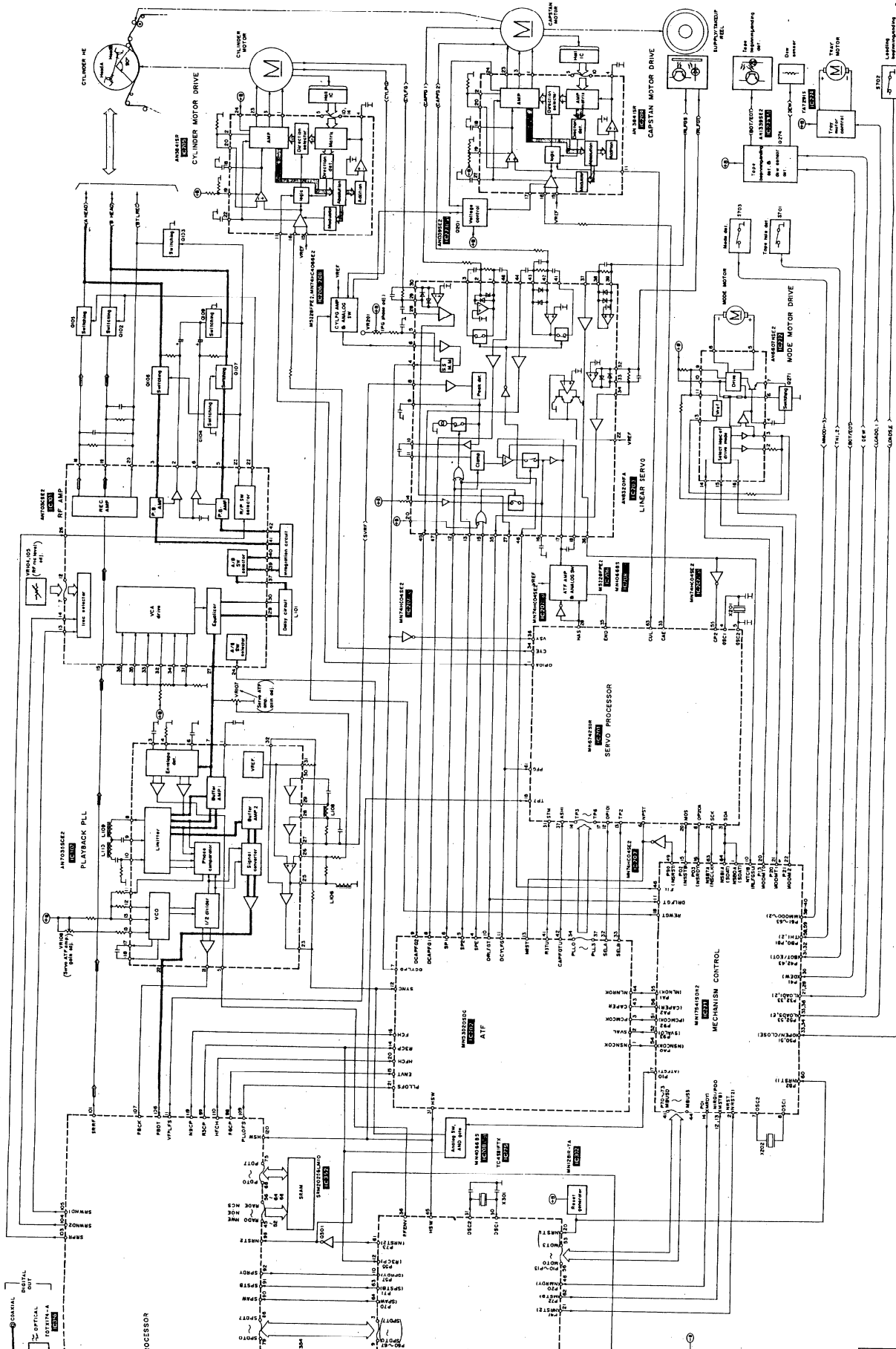

Note

- Playback signal
- Recording signal