

Specifications

REMOTE CONTROLLER

Model:	USR-5RF
Hardware:	High-resolution (320 × 240) liquid crystal display (LCD) with contrast control Large touchscreen Seven programmable direct-access buttons Backlighting for LCD and direct-access buttons Infrared sending and learning eyes 3-wire (RS232) serial port connector
Software:	Dynamic, animated interface Editable macros (up to 255 commands per macro) Total number of devices and macros limited only by memory Database with RC codes to operate different brands
Infrared (IR):	Operating distance of 33 feet (10 meters) Learning frequency up to 56 kHz Learning distance 2 inch (5 cm) up to 1 foot (30 cm)
Memory:	2 MB non-volatile flash memory (retains commands when batteries are not present) 512 K SRAM
Batteries:	4 AA 1.5 V batteries, or one 4.8V rechargeable battery pack
Battery life:	Approximately 6 months with typical use
Power management:	Power on by tapping the touchscreen, power off automatically management
Dimensions:	6.0 inch × 3.7 inch × 1.7 inch (153.6 × 94.1 × 43.7 mm)
Operating temperature:	32 °F to 122 °F (0 °C to 50 °C)
Radio frequency (RF):	Operating distance of approximately 66 feet (20 meters) depending on the surrounding conditions Band: 418 MHz Bandwidth: +/-100 kHz 16 Extender ID's and 4 Channels
Accessories (Not included):	Remote controller recharge package BCC-5 RF Receiver RFR-5

Database information:
Designed by UEI Technology
Licensed under U.S. Patent 5,689,353
Portions © UEI 1999

The specifications and design of this product are subject to change without notice.

A **B** **C** **D**

BLOCK DIAGRAM - 1

1

2

3

4

5

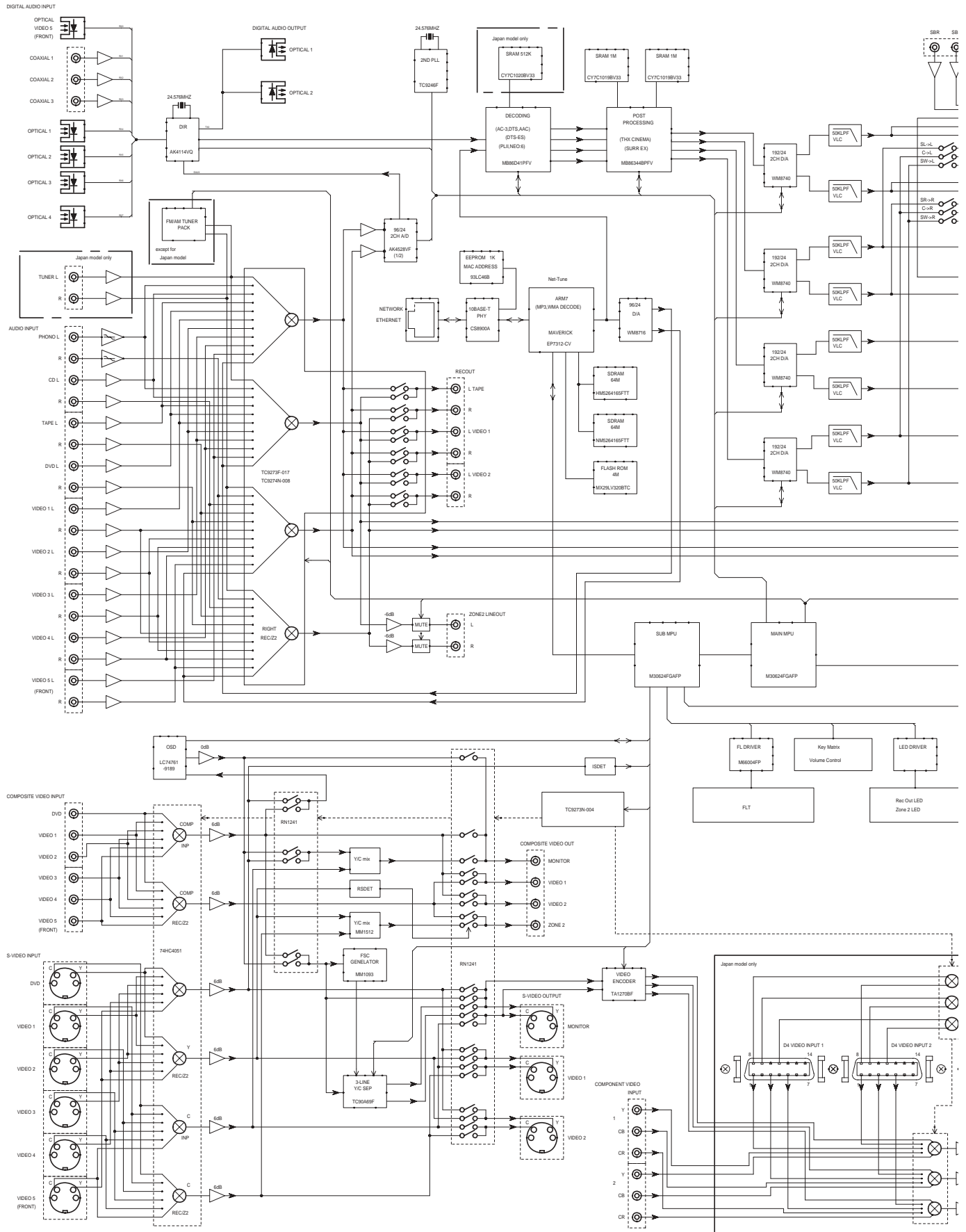

SCHEMATIC DIAGRAM (DISPLAY, SUB-MICON)-1

1

2

3

4

5

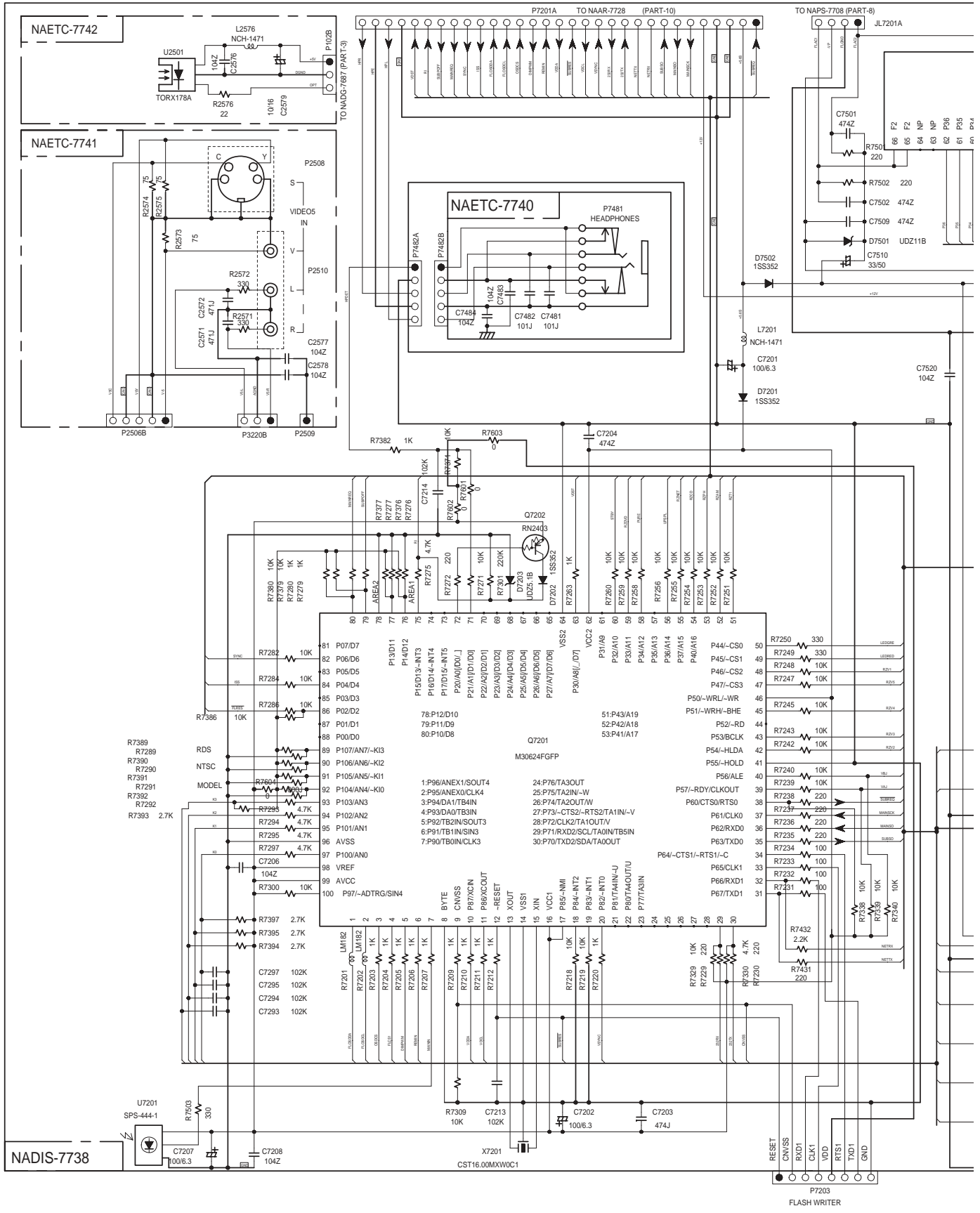

A B C D

SCHEMATIC DIAGRAM (DISPLAY, SUB-MICON)-2

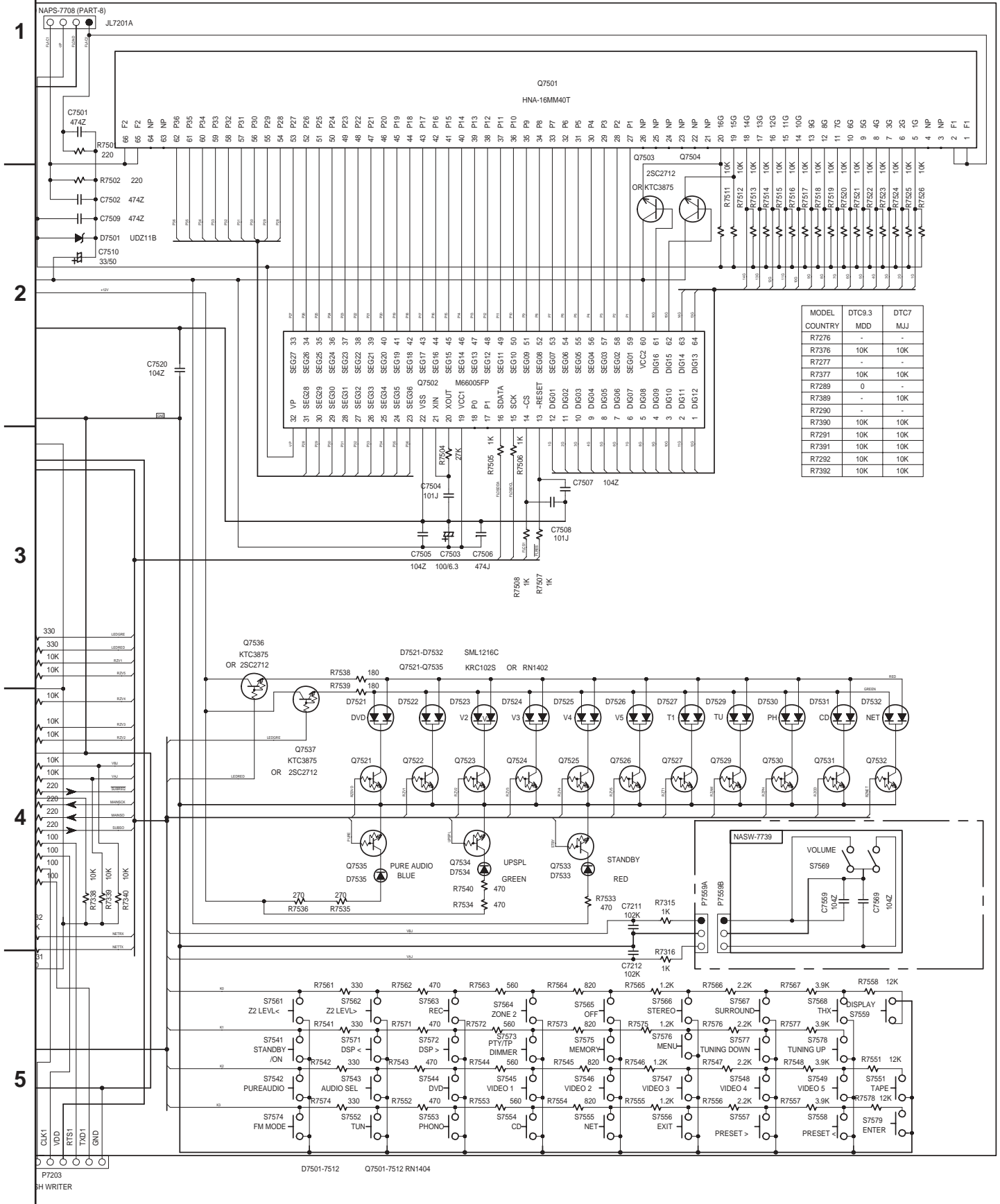

P7203
SH WRITER

D7501-7512 Q7501-7512 RN1404

SCHEMATIC DIAGRAM (DSP MAIN MPU)-1

1

2

3

4

5

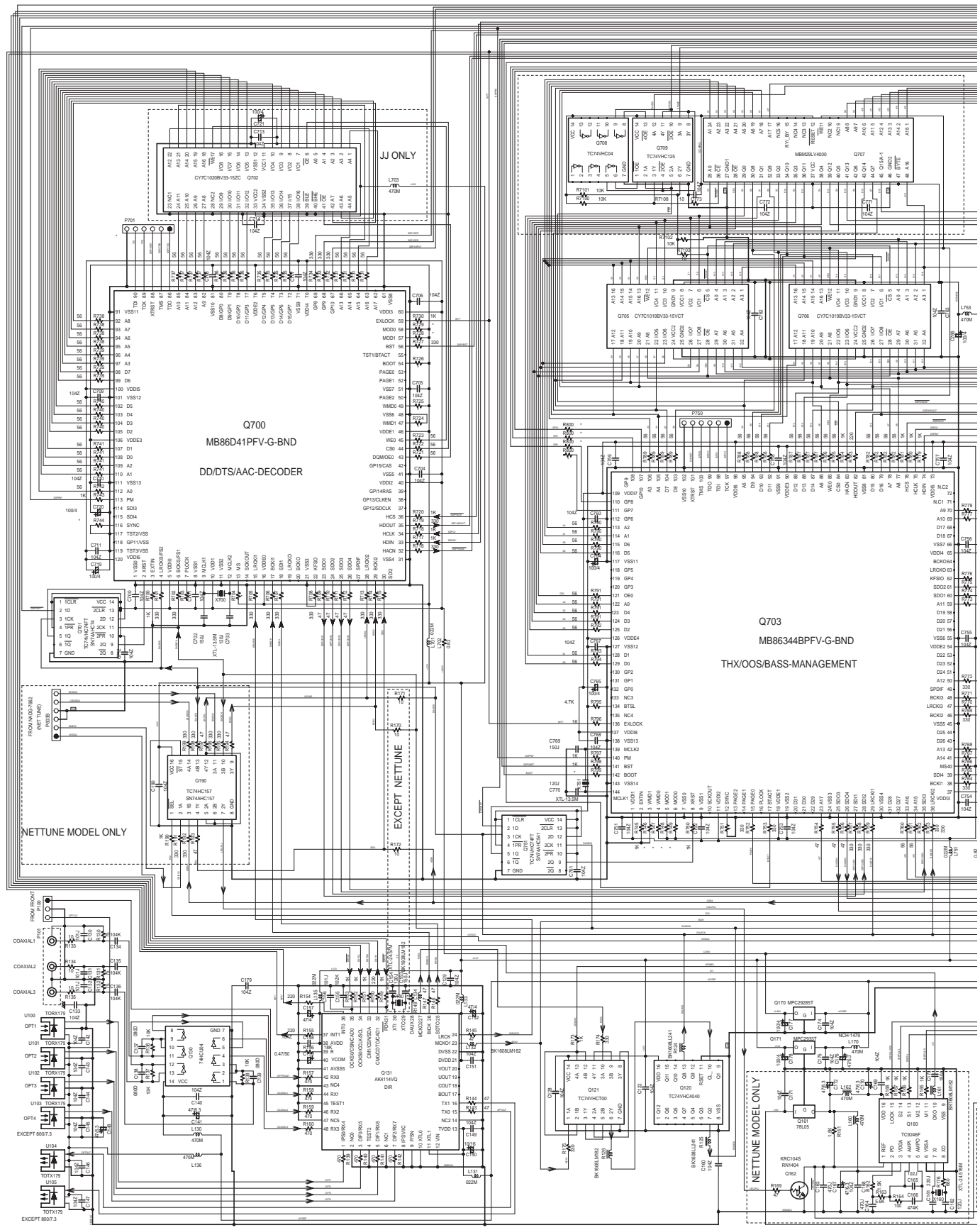

A B C D

SCHEMATIC DIAGRAM (DSP MAIN MPU)-2

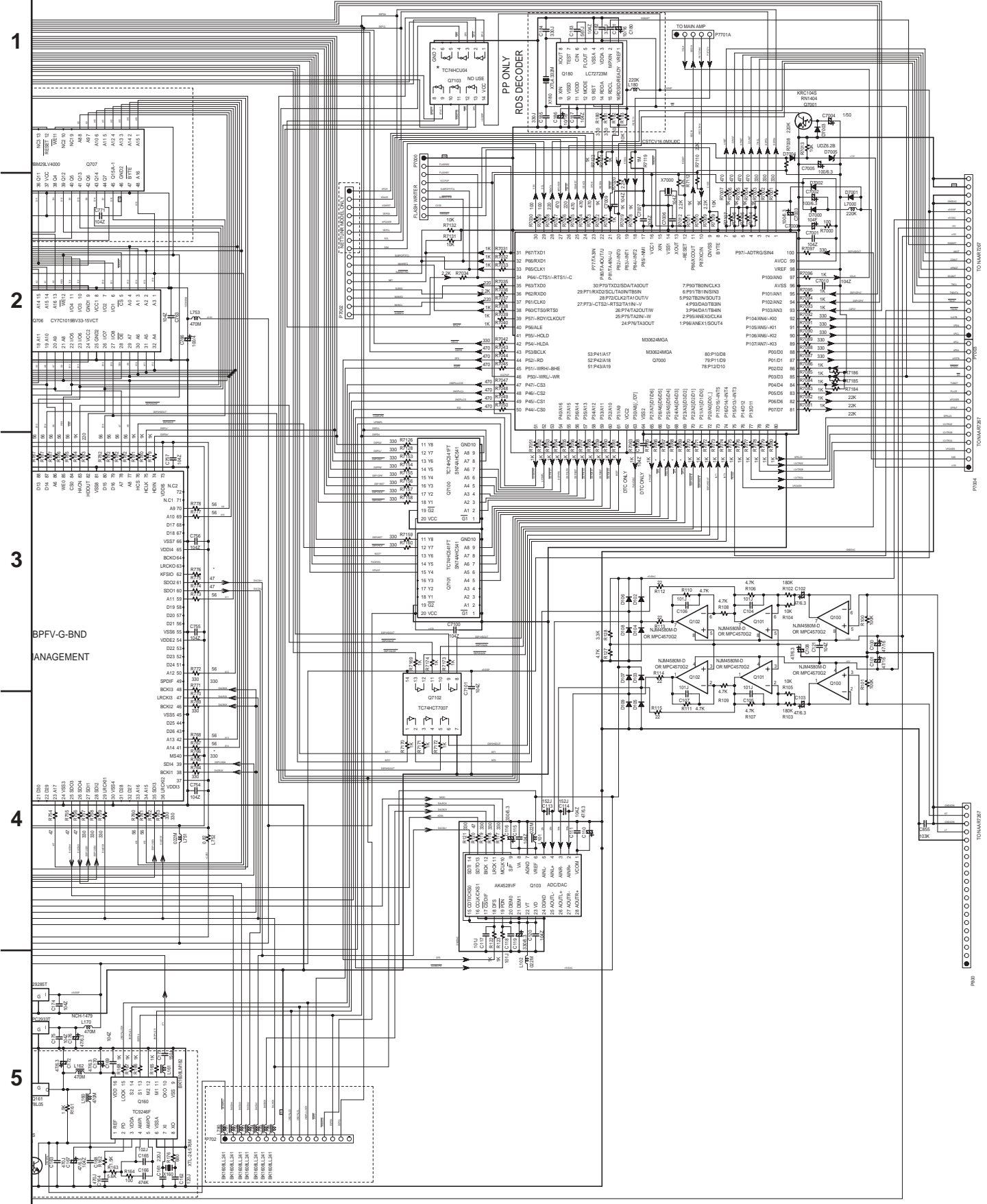

A B C D

SCHEMATIC DIAGRAM (AUDIO INPUT OUTPUT)-1

1
2
3
4
5

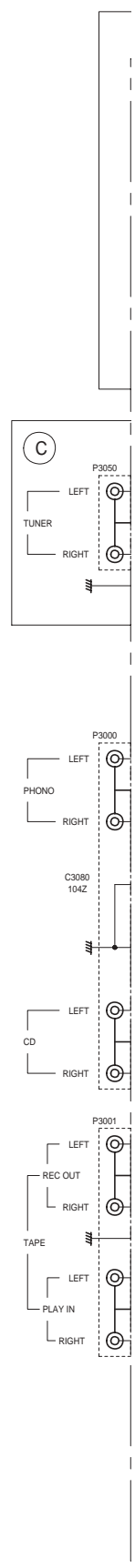
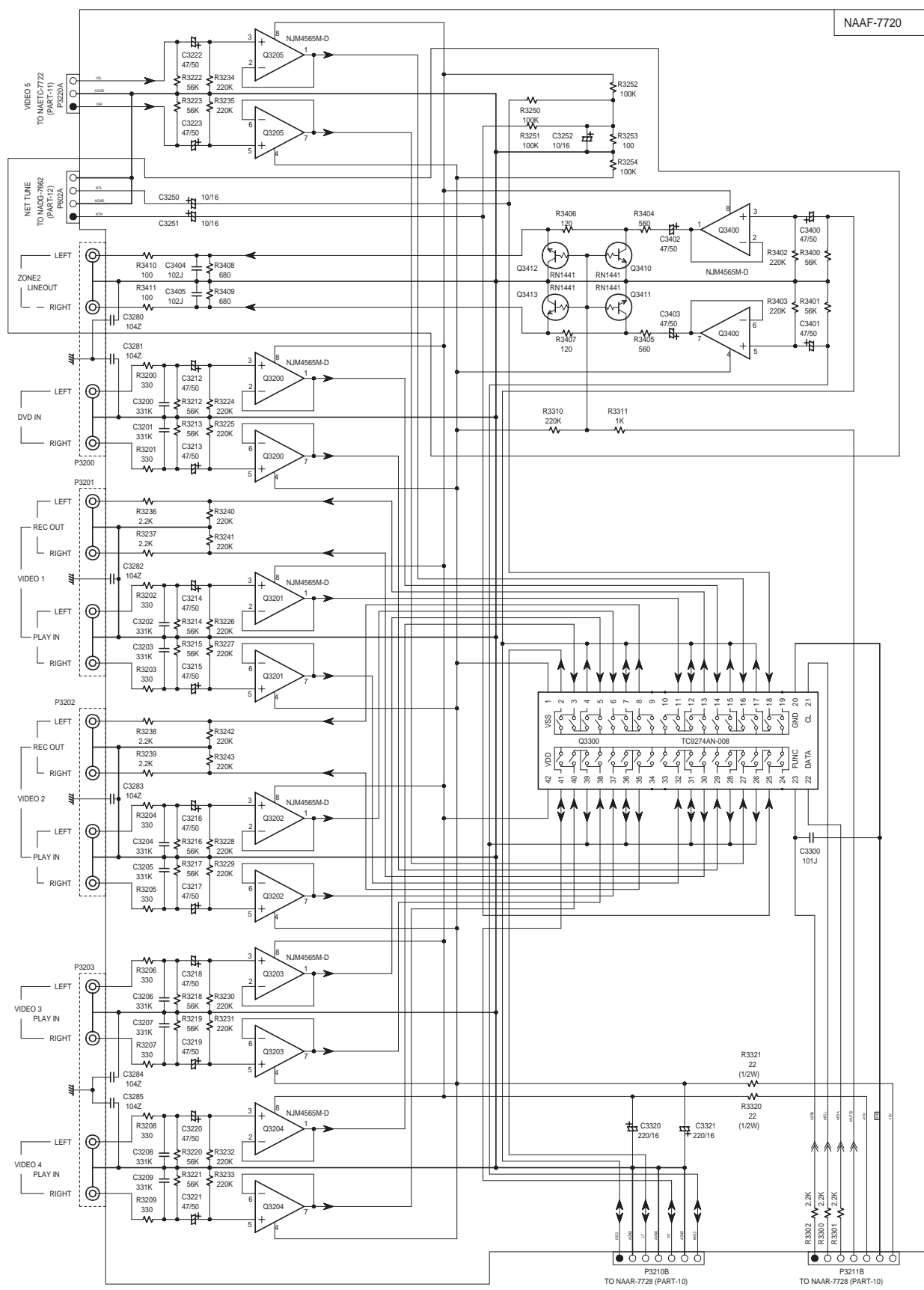

NAAF-7720

P3210B TO NAAR-7728 (PART-10)
P3211B TO NAAR-7728 (PART-10)

A B C D

SCHEMATIC DIAGRAM (CONFIG VOLUME TONE PREOUT)-1

1

2

3

4

5

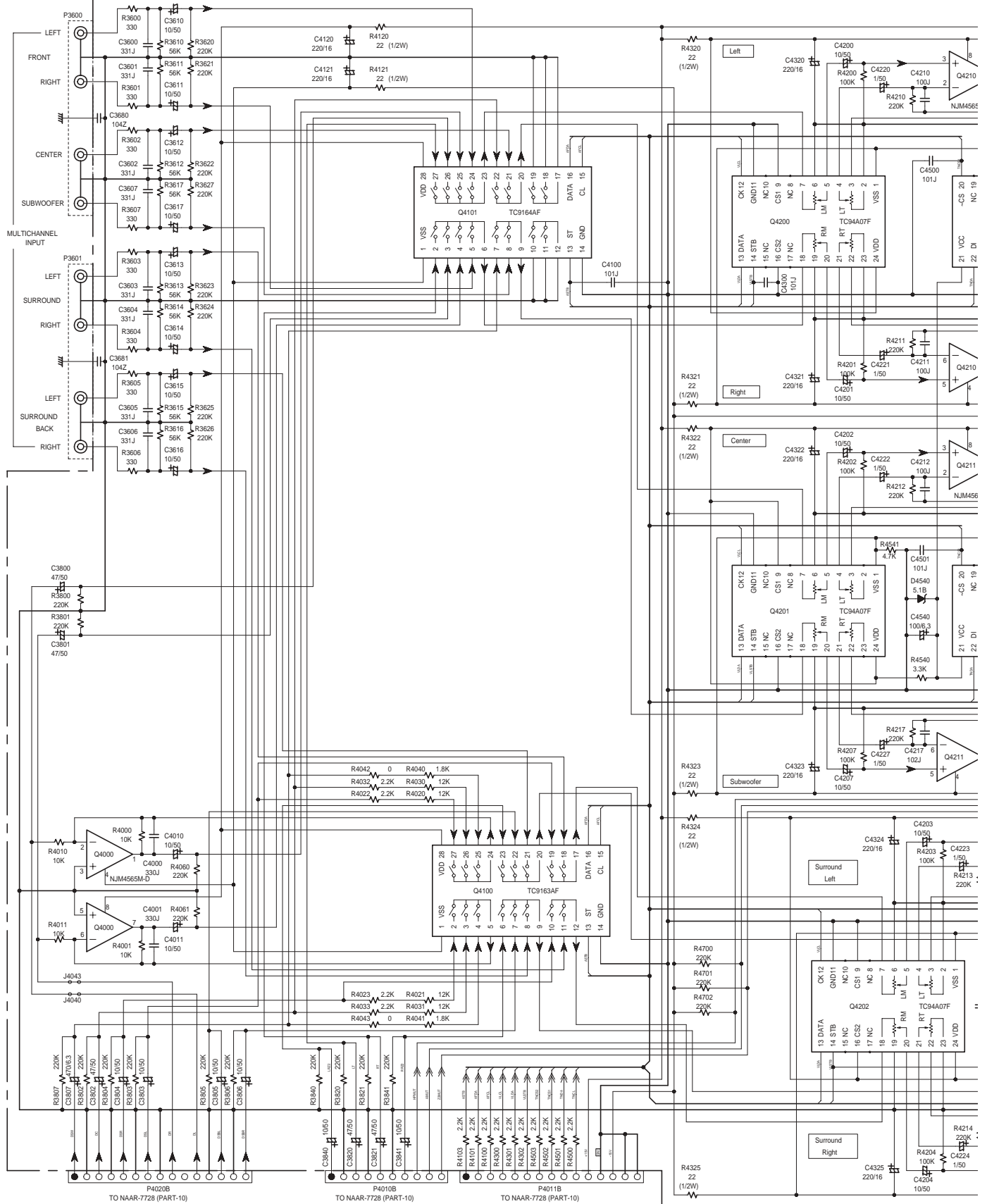

TO NAAR-7728 (PART-10)

TO NAAR-7728 (PART-10)

TO NAAR-7728 (PART-10)

TO NAAR-7728 (PART-10)

A B C D

SCHEMATIC DIAGRAM (BALANCED PREOUT)-1

1

2

3

4

5

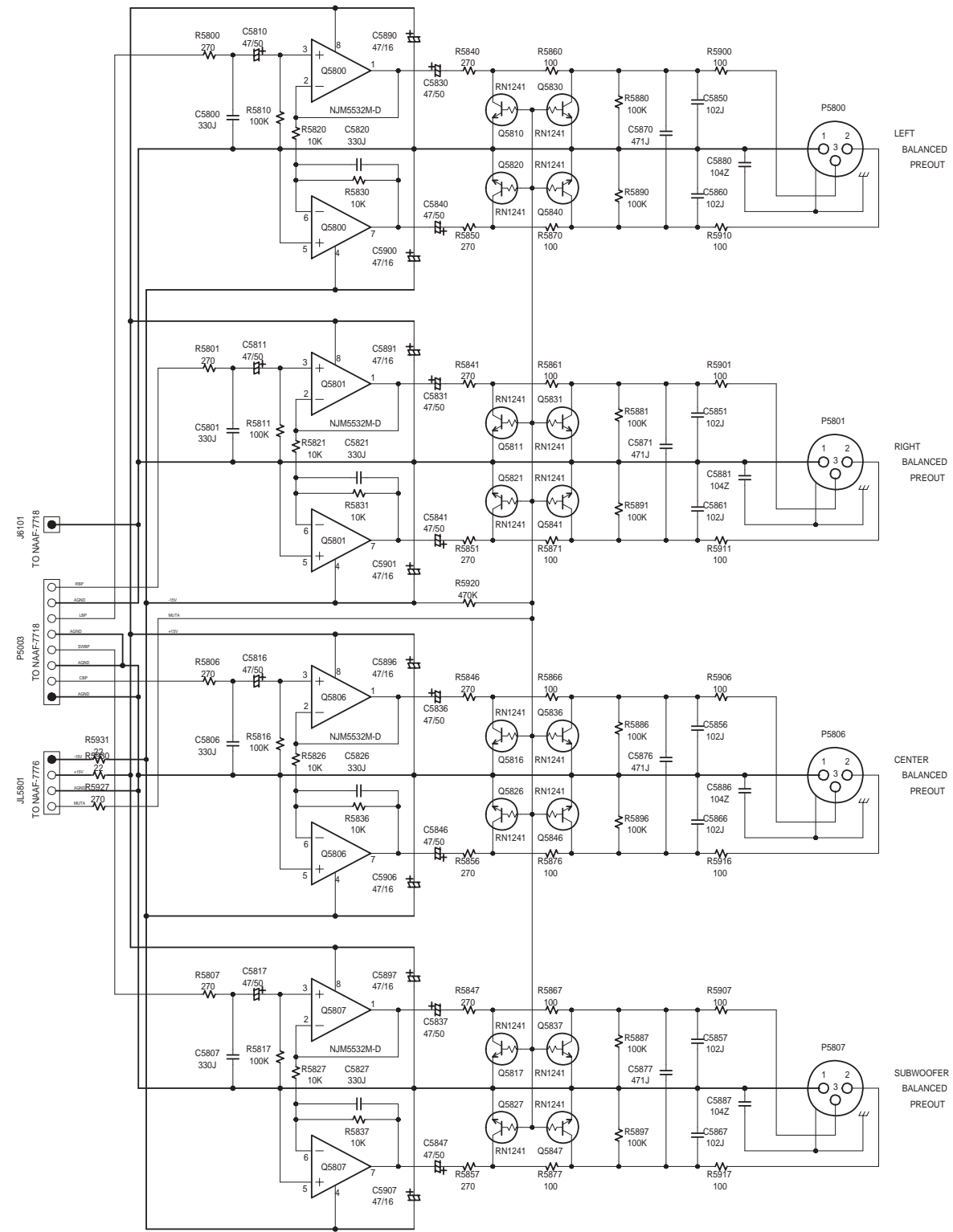

LEFT
BALANCED
PREOUT

RIGHT
BALANCED
PREOUT

CENTER
BALANCED
PREOUT

SUBWOOFER
BALANCED
PREOUT

A

B

C

D

SCHEMATIC DIAGRAM (BALANCED PREOUT)-2

1

2

3

4

5

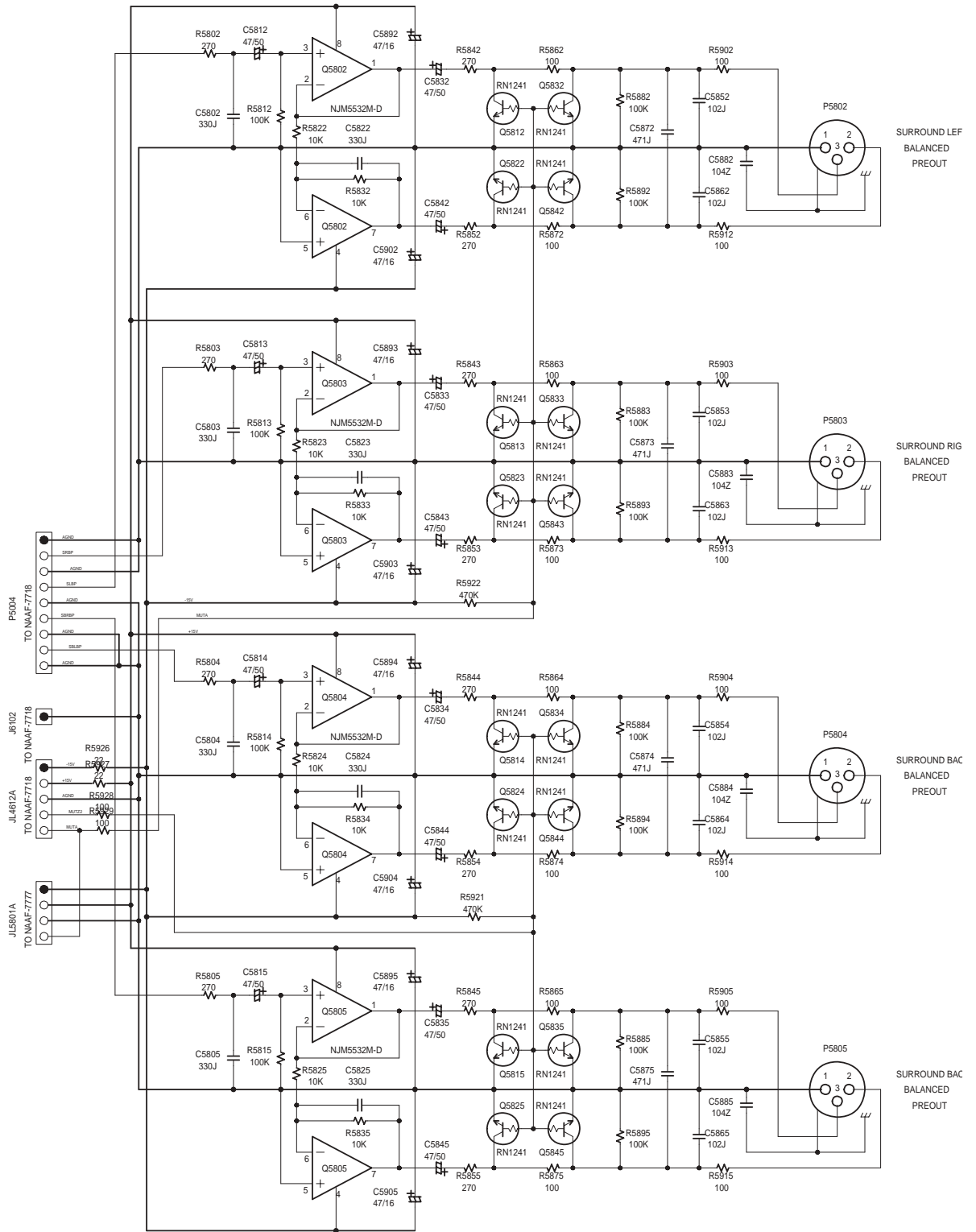

A B C D
SCHEMATIC DIAGRAM (DAC, VLSC, POWER)-1

1

2

3

4

5

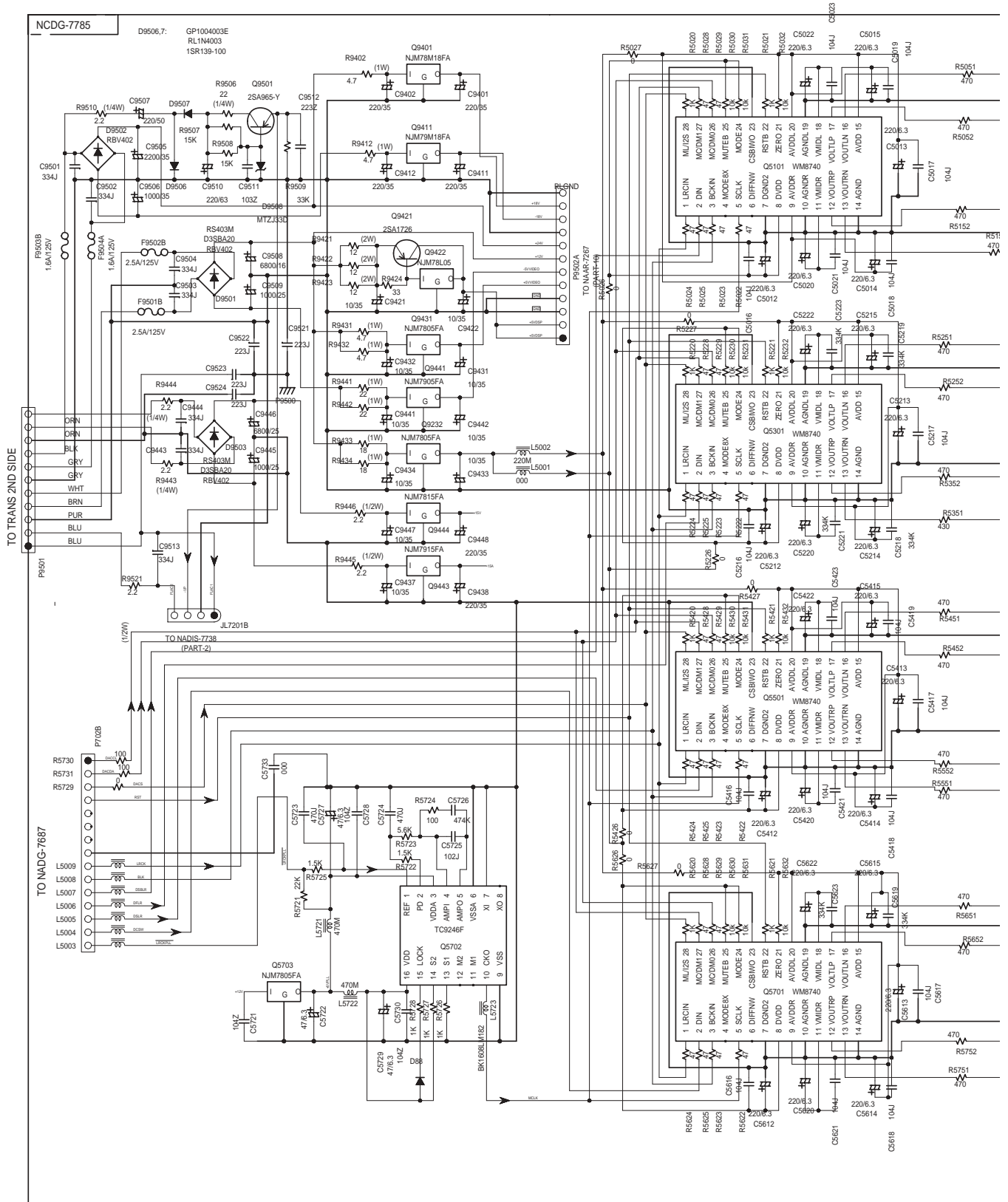

A B C D
SCHEMATIC DIAGRAM (POWER SUPPLY, COMPONENT VIDEO)-1

1

2

3

4

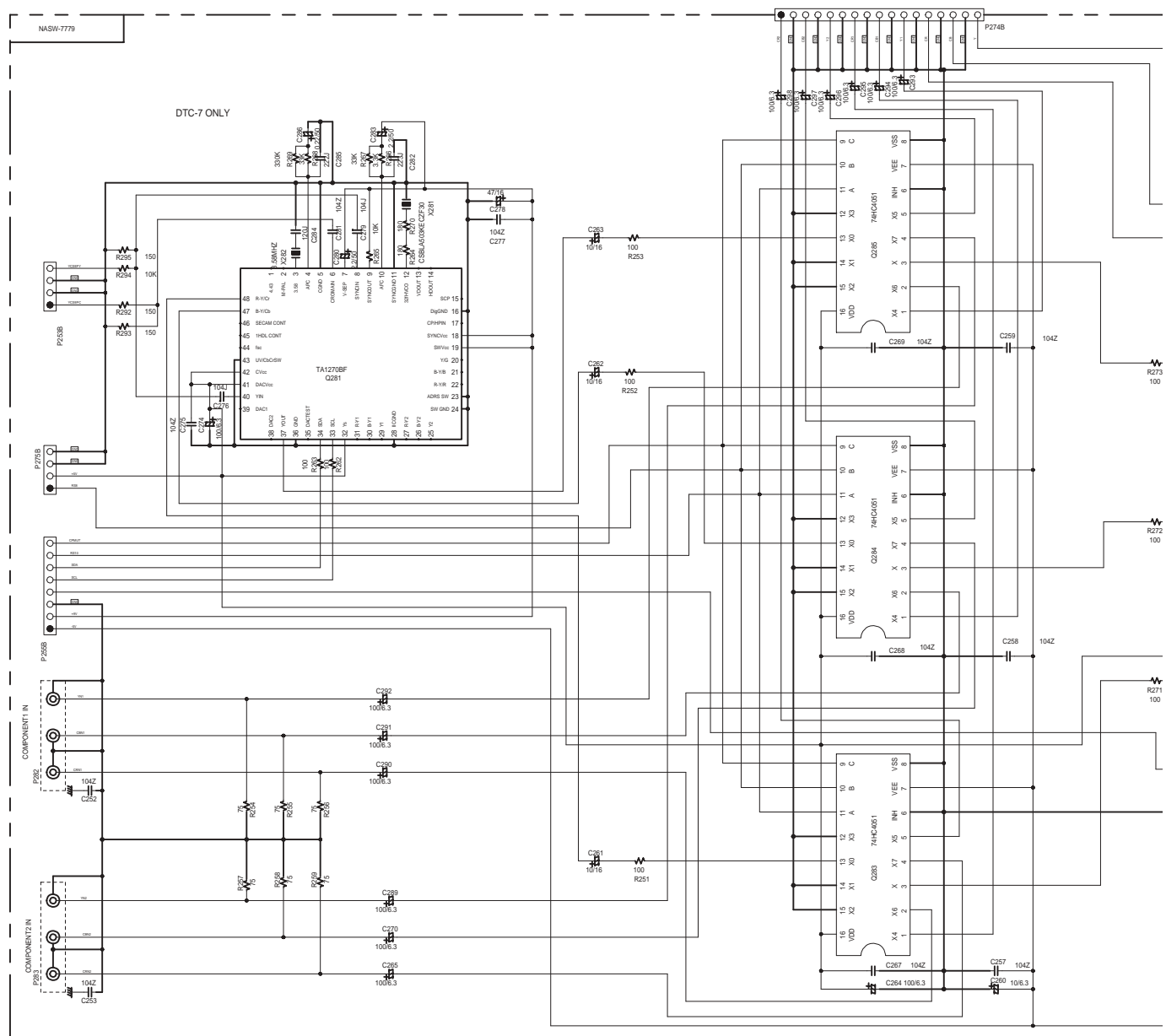

5

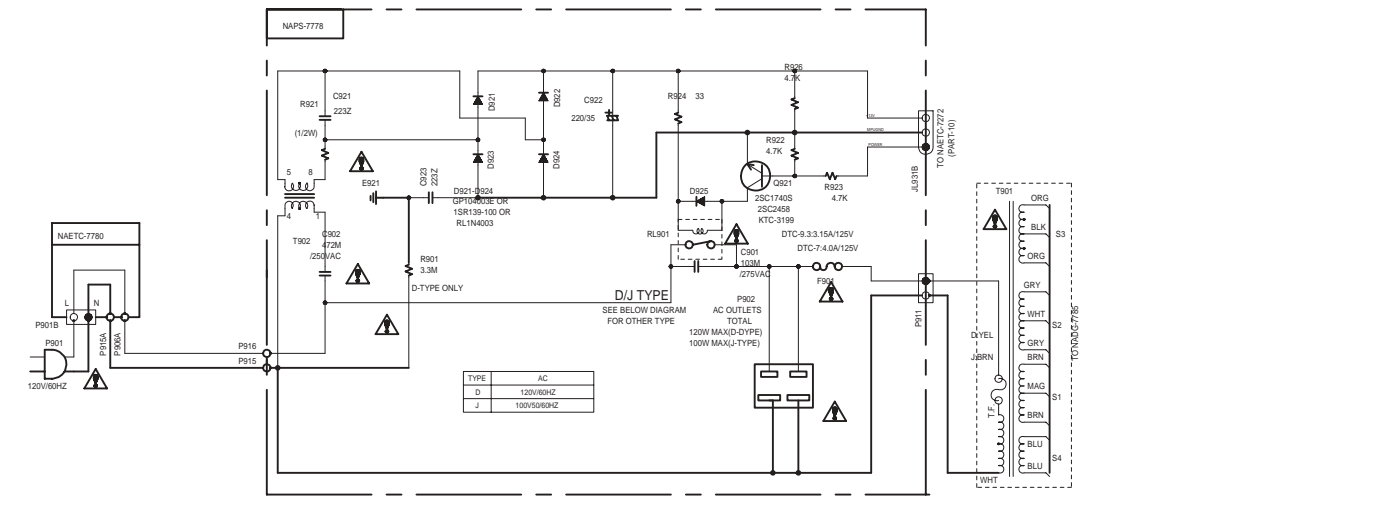

A B C D
SCHEMATIC DIAGRAM (POWER SUPPLY, COMPONENT VIDEO)-2

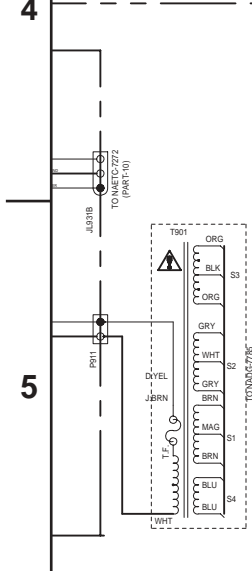
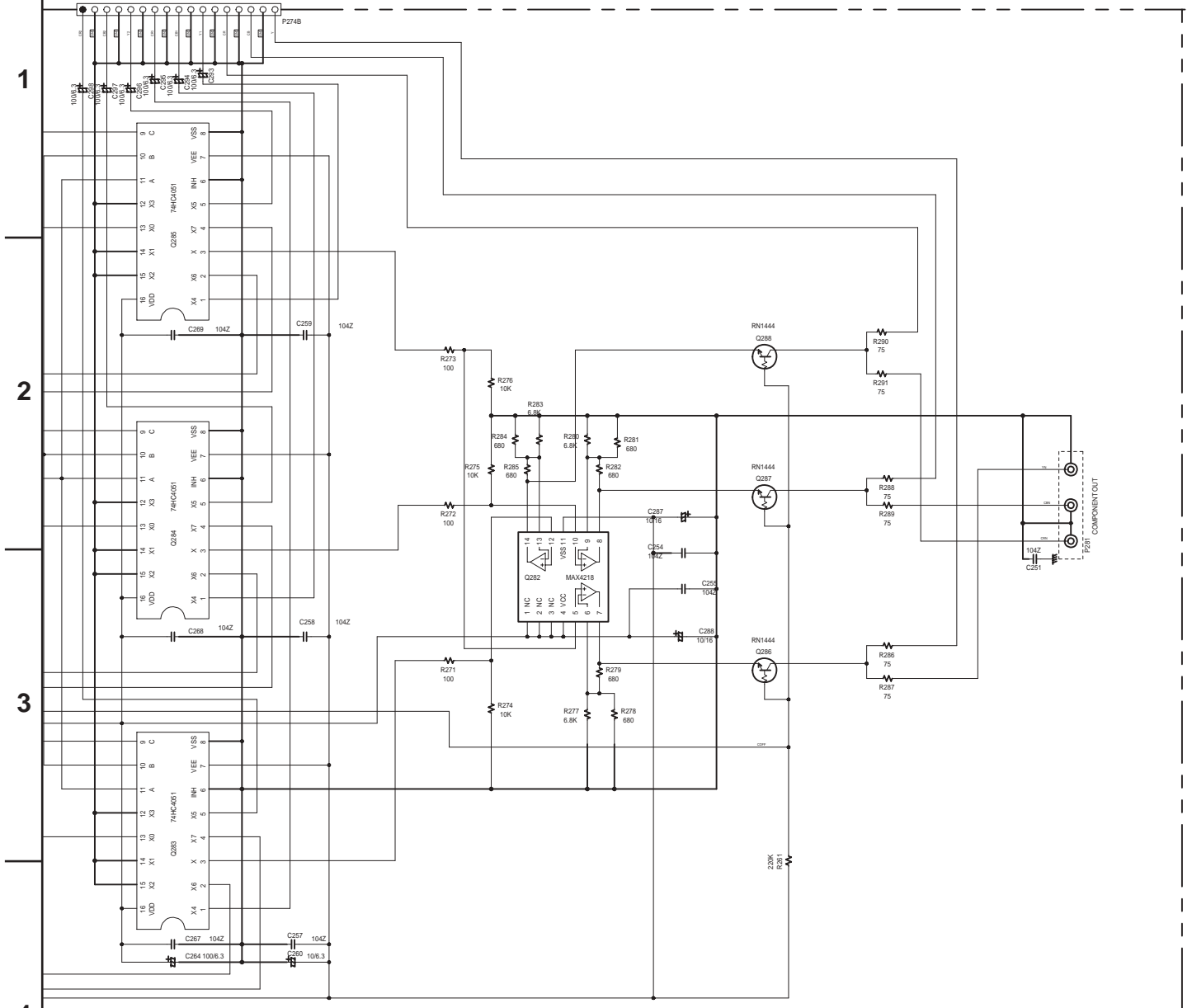

 THIS SYMBOL LOCATED NEAR THE FUSE INDICATES THAT THE FUSE USED IS SLOW OPERATING TYPE FOR CONTINUED PROTECTION AGAINST FIRE HAZARD. REPLACE WITH SAME TYPE FUSE. FOR FUSE RATING REFER TO THE MARKING ADJACENT TO THE SYMBOL.

CAUTION
 FOR CONTINUED PROTECTION AGAINST FIRE HAZARD, REPLACE ONLY WITH FUSE OF SAME TYPE AND RATING INDICATED.

 CE SYMBOLE INDIQUE QUE LE FUSIBLE UTILISE EST LENT. POUR UNE PROTECTION PERMANENTE CONTRE LES RISQUES D'INCENDIE, REMPLACER UNIQUEMENT QUE DES FUSIBLES DE MEME TYPE. CE DERNIER EST INDIQUE LA OU LE PRESENT SYMBOLE EST APPOSE.

ATTENTION
 AFIN D'ASSURER UNE PROTECTION PERMANENTE CONTRE LES RISQUES D'INCENDIE, REMPLACER UNIQUEMENT PAR UN FUSIBLE DE MEME TYPE ET CALIBRATION COMME INDIQUE.

A B C D
SCHEMATIC DIAGRAM (POWER SUPPLY, COMPONENT VIDEO)-1

1

2

3

4

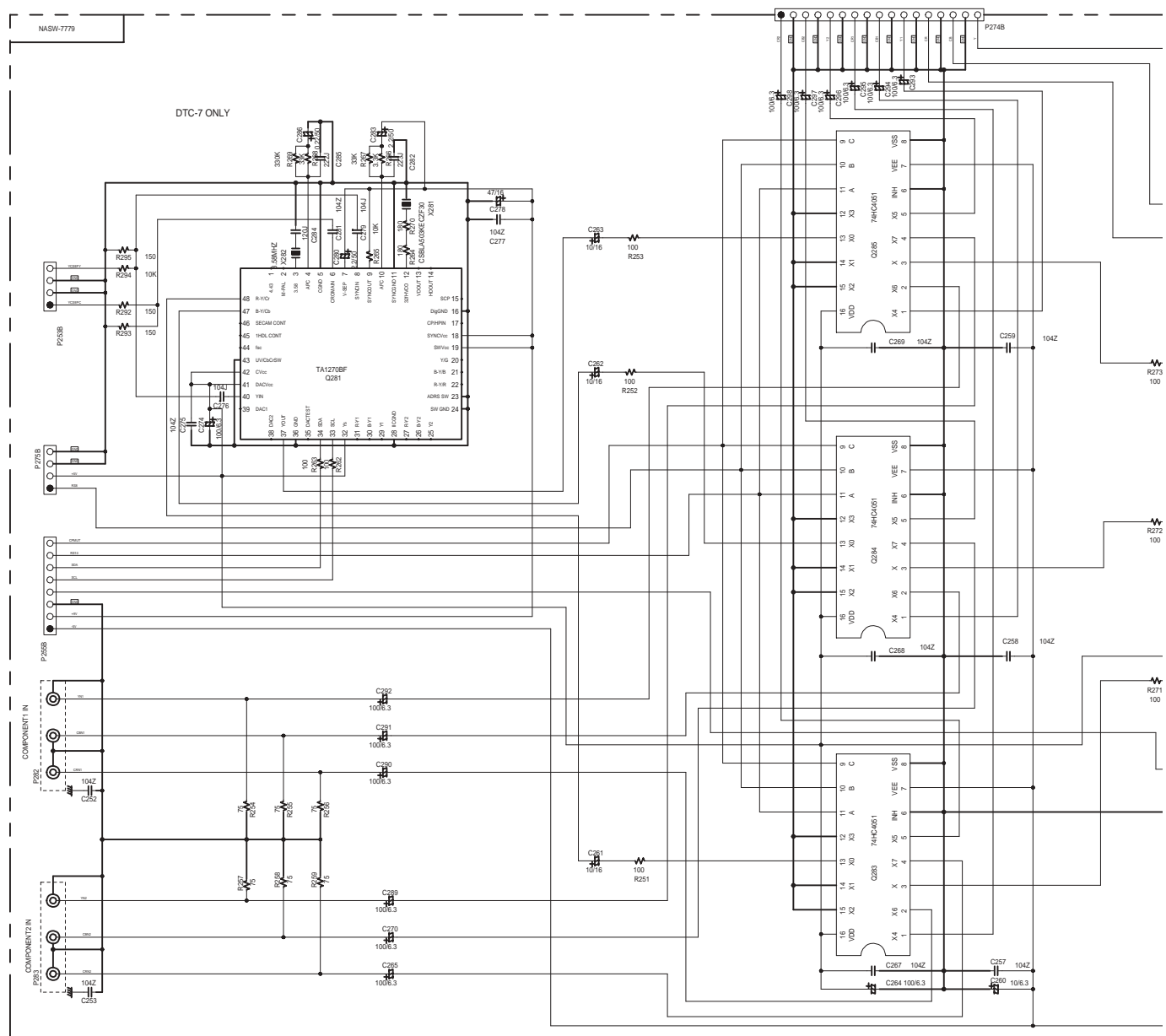

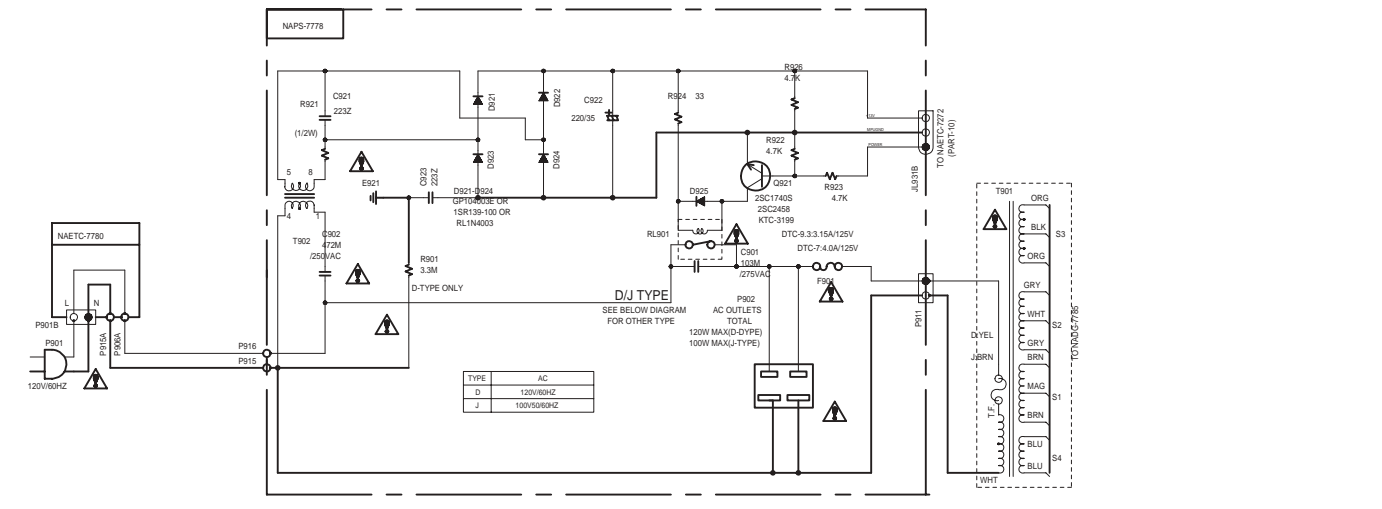

5

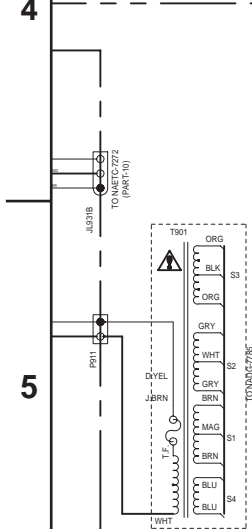
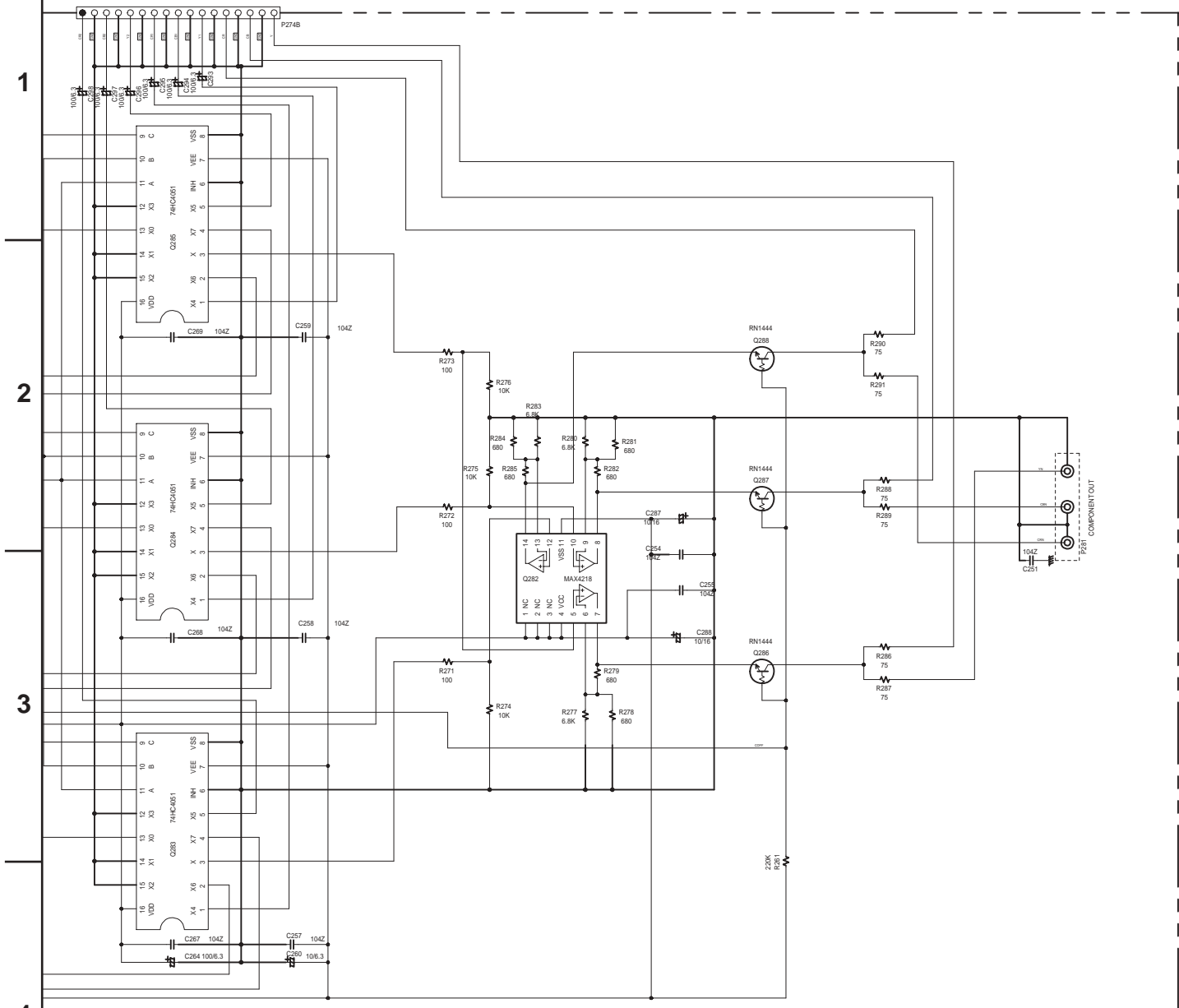

A B C D

SCHEMATIC DIAGRAM (POWER SUPPLY, COMPONENT VIDEO)-2



 THIS SYMBOL LOCATED NEAR THE FUSE INDICATES THAT THE FUSE USED IS SLOW OPERATING TYPE FOR CONTINUED PROTECTION AGAINST FIRE HAZARD. REPLACE WITH SAME TYPE FUSE. FOR FUSE RATING REFER TO THE MARKING ADJACENT TO THE SYMBOL.

CAUTION
FOR CONTINUED PROTECTION AGAINST FIRE HAZARD, REPLACE ONLY WITH FUSE OF SAME TYPE AND RATING INDICATED.

 CE SYMBOLE INDIQUE QUE LE FUSIBLE UTILISE EST LENT. POUR UNE PROTECTION PERMANENTE CONTRE LES RISQUES D'INCENDIE, REMPLACER UNIQUEMENT QUE DES FUSIBLES DE MEME TYPE. CE DERNIER EST INDIQUE LA OU LE PRESENT SYMBOLE EST APPOSE.

ATTENTION
AFIN D'ASSURER UNE PROTECTION PERMANENTE CONTRE LES RISQUES D'INCENDIE, REMPLACER UNIQUEMENT PAR UN FUSIBLE DE MEME TYPE ET CALIBRATION COMME INDIQUE.

A B C D
SCHEMATIC DIAGRAM (MOTHER BOARD)-1

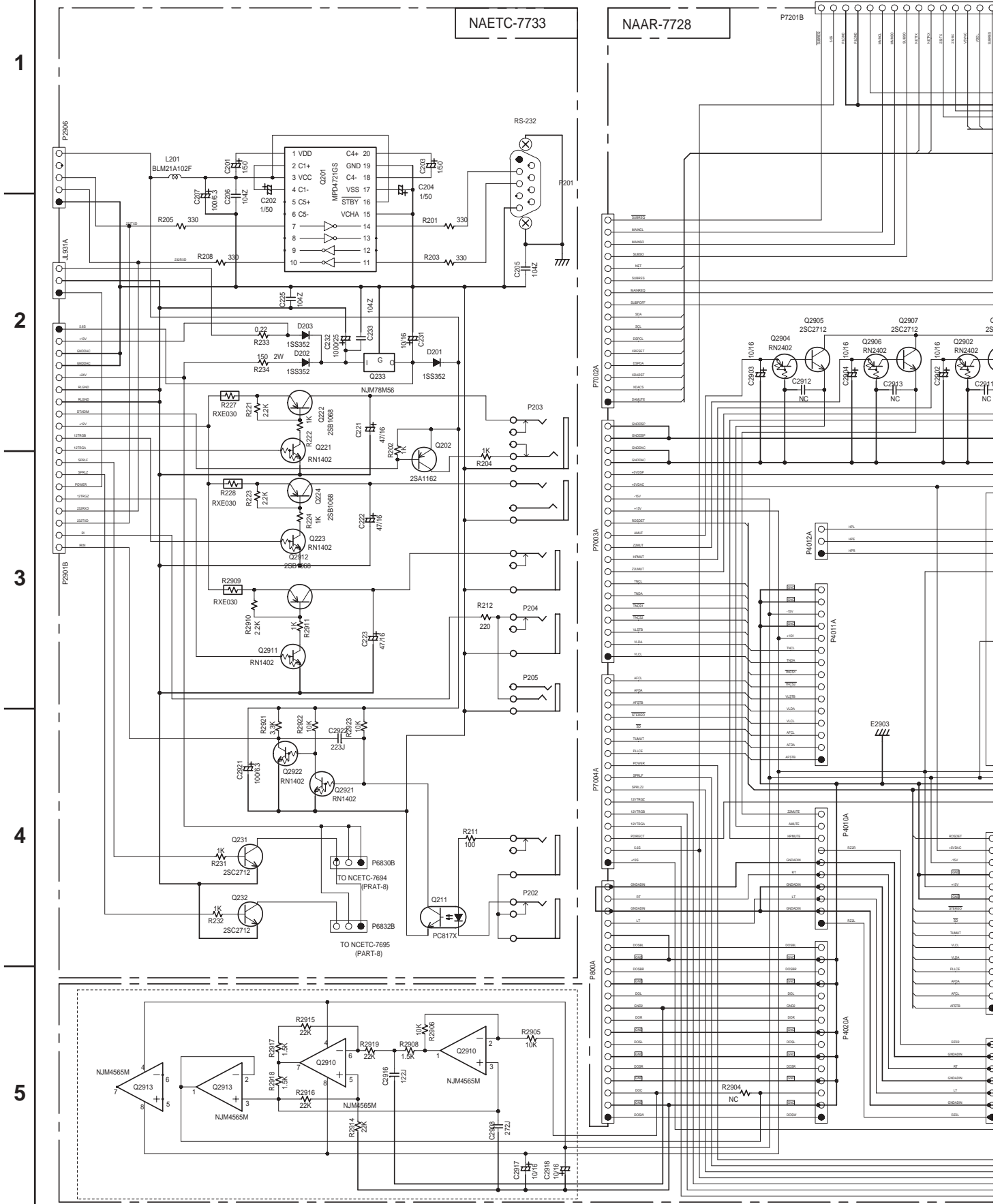

A B C D

SCHEMATIC DIAGRAM (MOTHER BOARD)-2

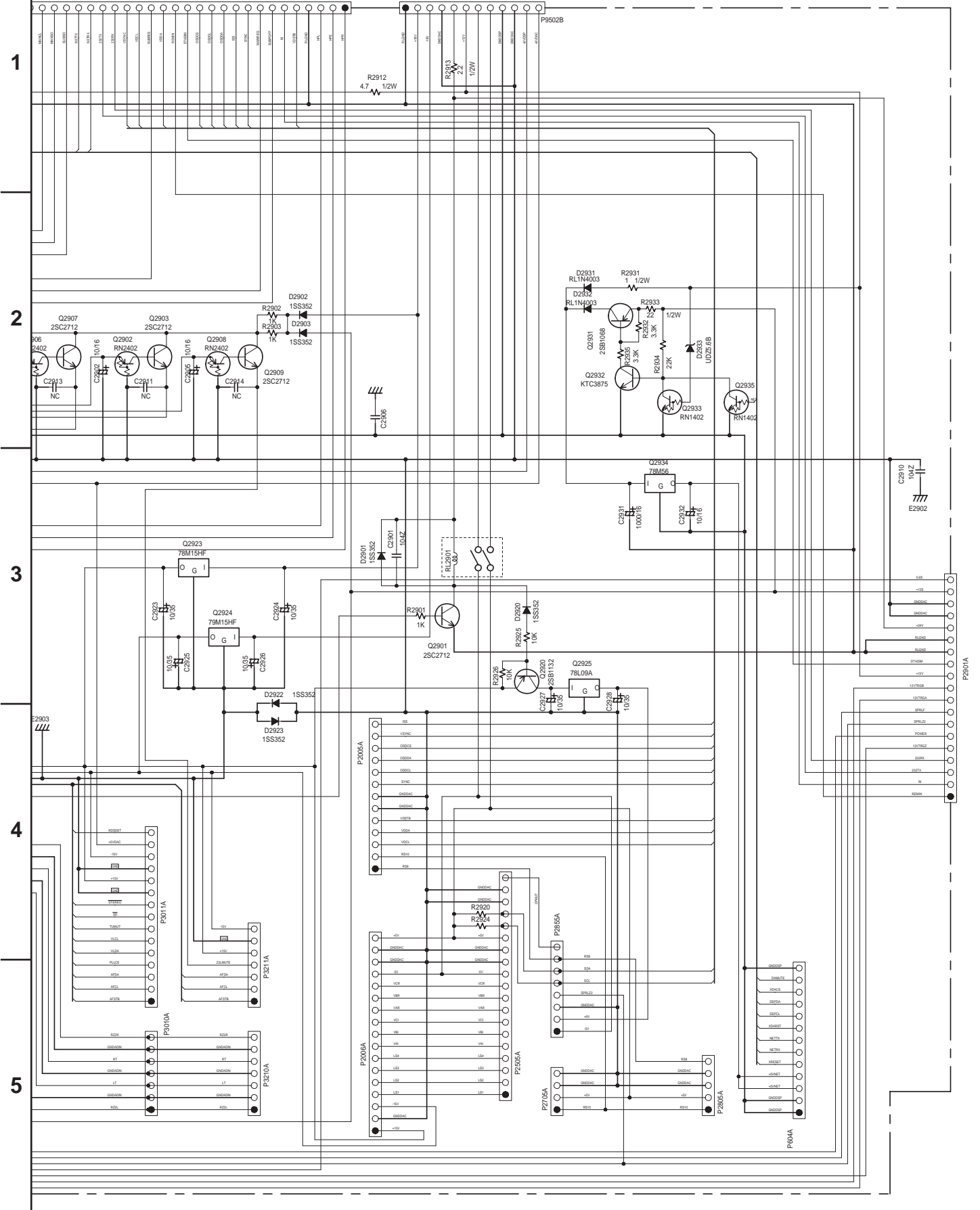

A **B** **C** **D**

BLOCK DIAGRAM - 1

1

2

3

4

5

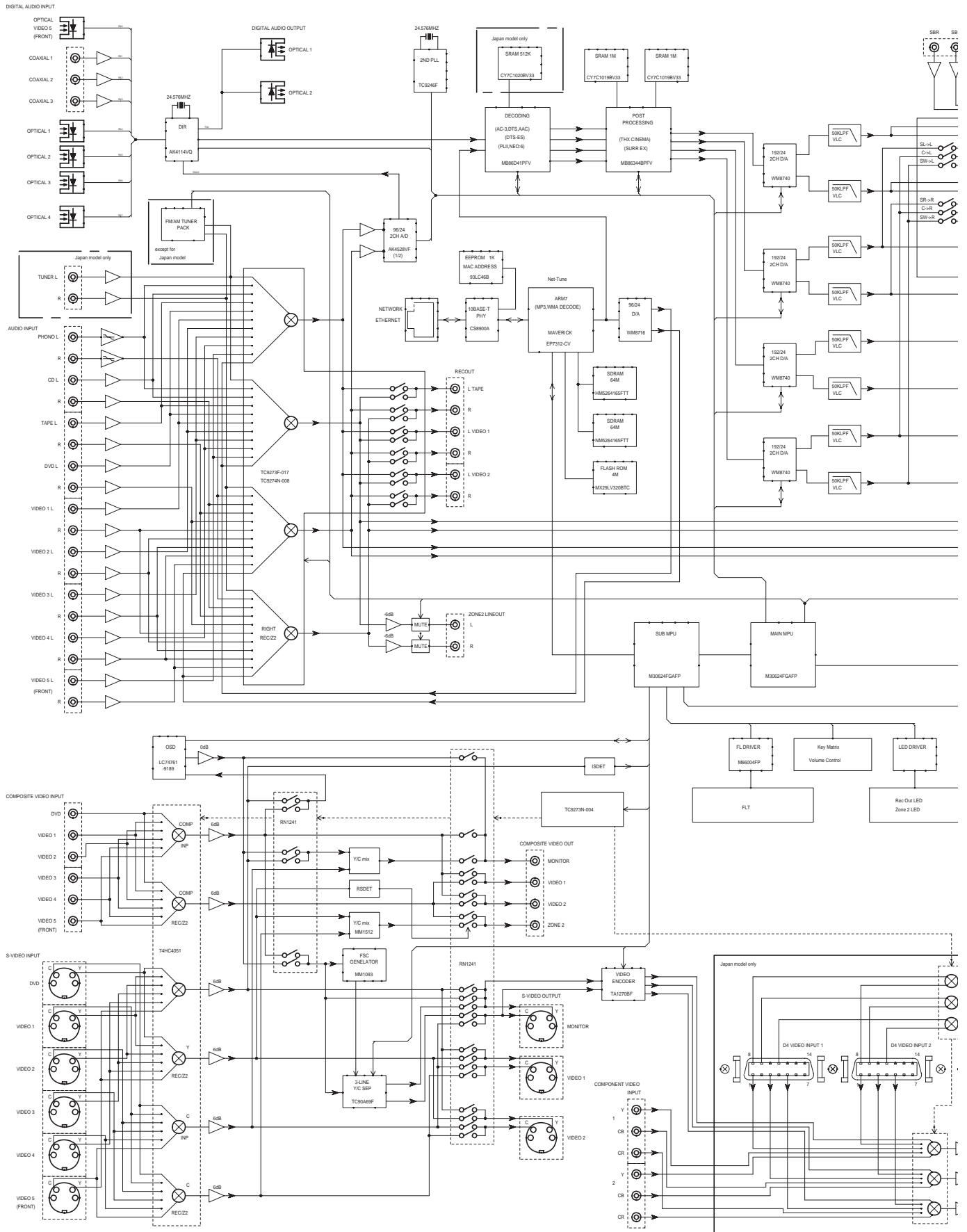

SCHEMATIC DIAGRAM (VIDEO)-1

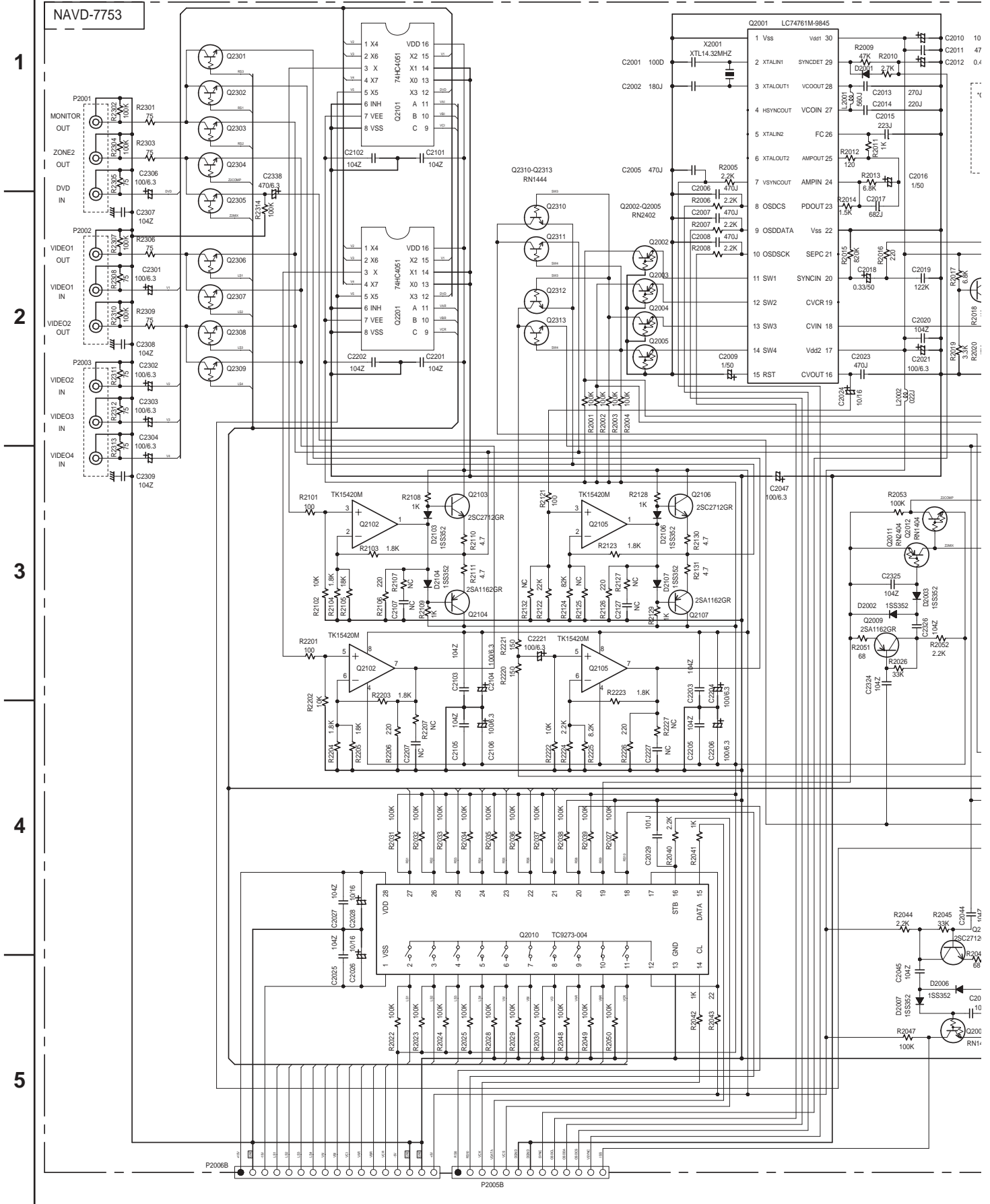

A B C D
SCHEMATIC DIAGRAM (VIDEO)-2

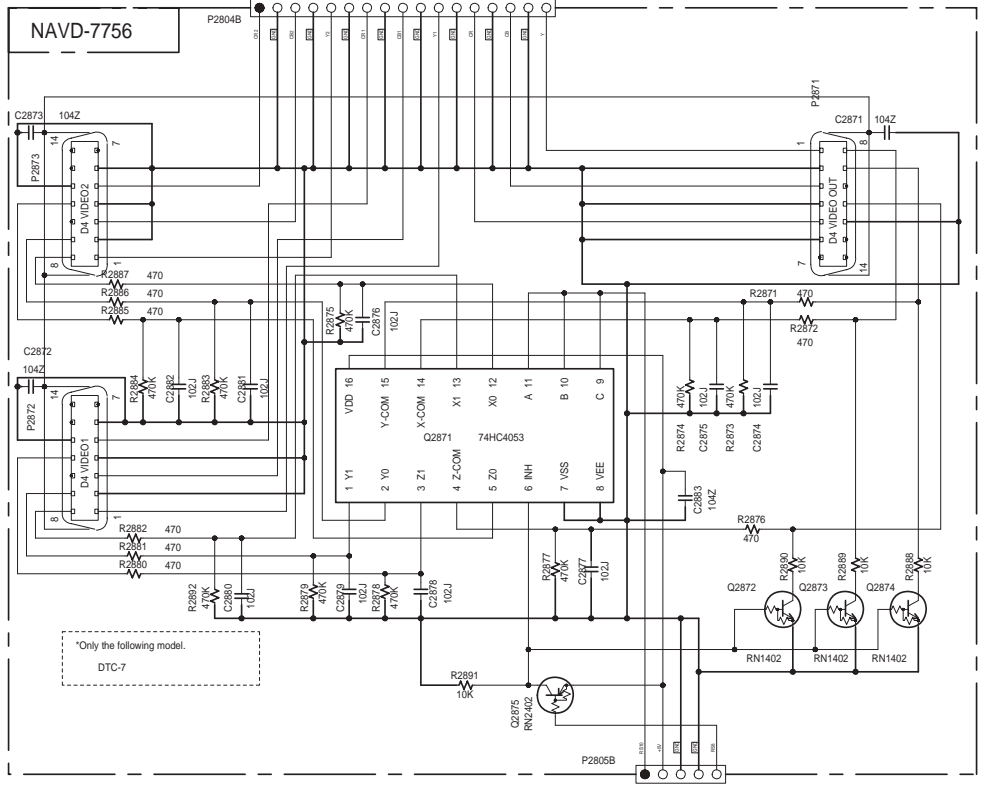
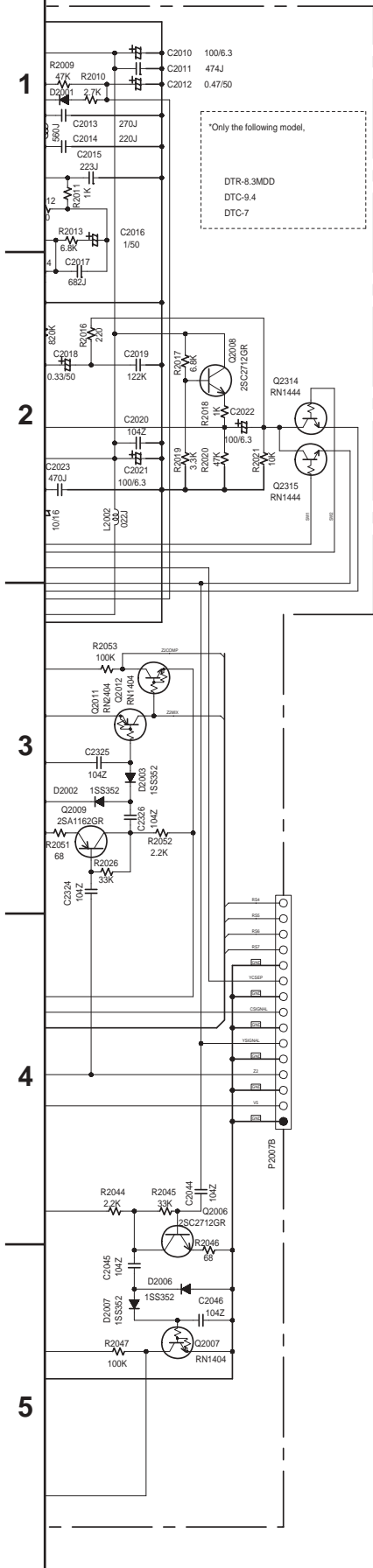

A B C D

SCHEMATIC DIAGRAM (VIDEO)-3

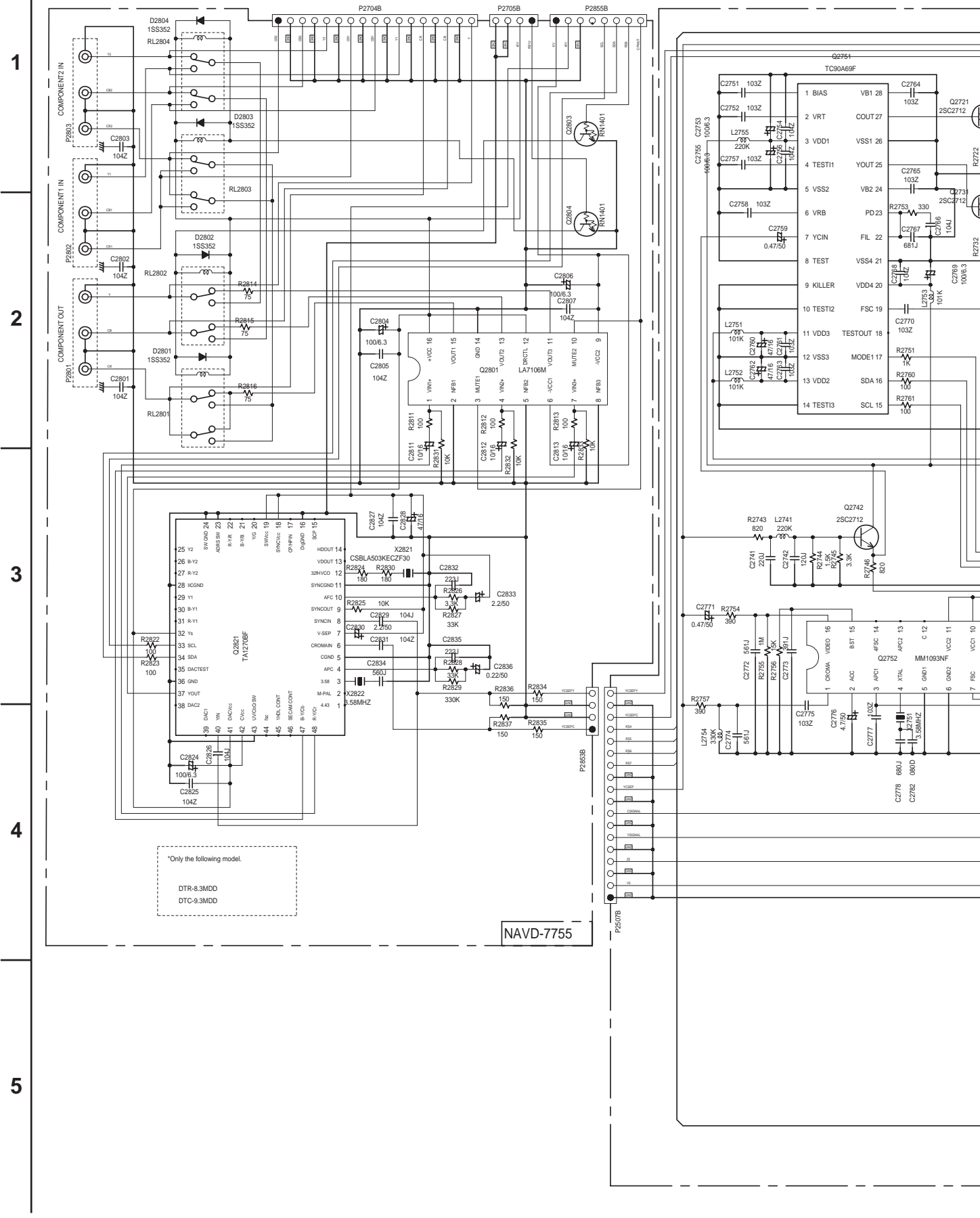

*Only the following model.
DTR-8.3MDD
DTC-9.3MDD

NAVD-7755

A **B** **C** **D**

SCHEMATIC DIAGRAM (VIDEO)-4

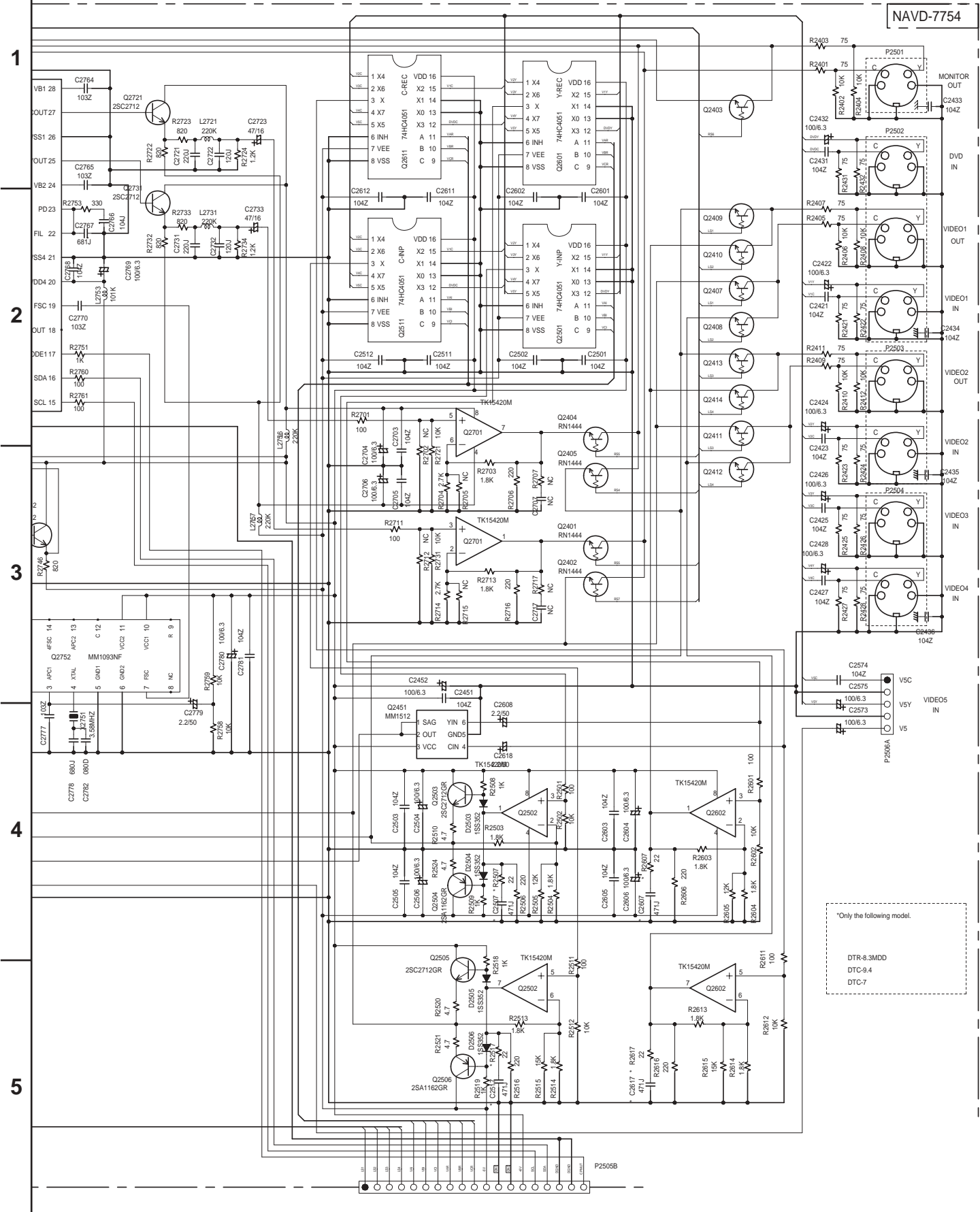

SCHEMATIC DIAGRAM (VIDEO)-3

1
2
3
4
5

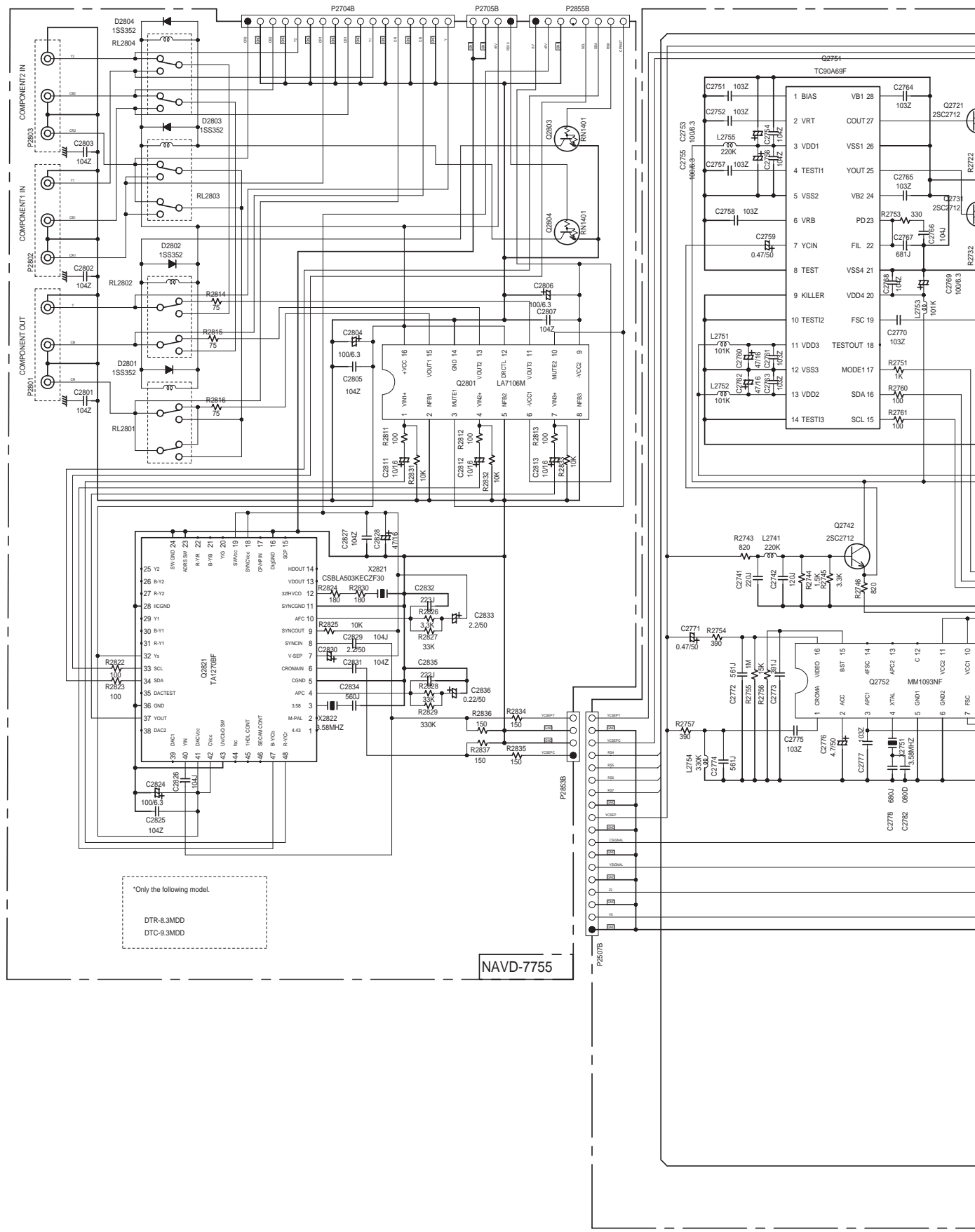

Only the following model.

DTR-8.3MDD
DTC-9.3MDD

NAVD-7755

A B C D
SCHEMATIC DIAGRAM (VIDEO)-4

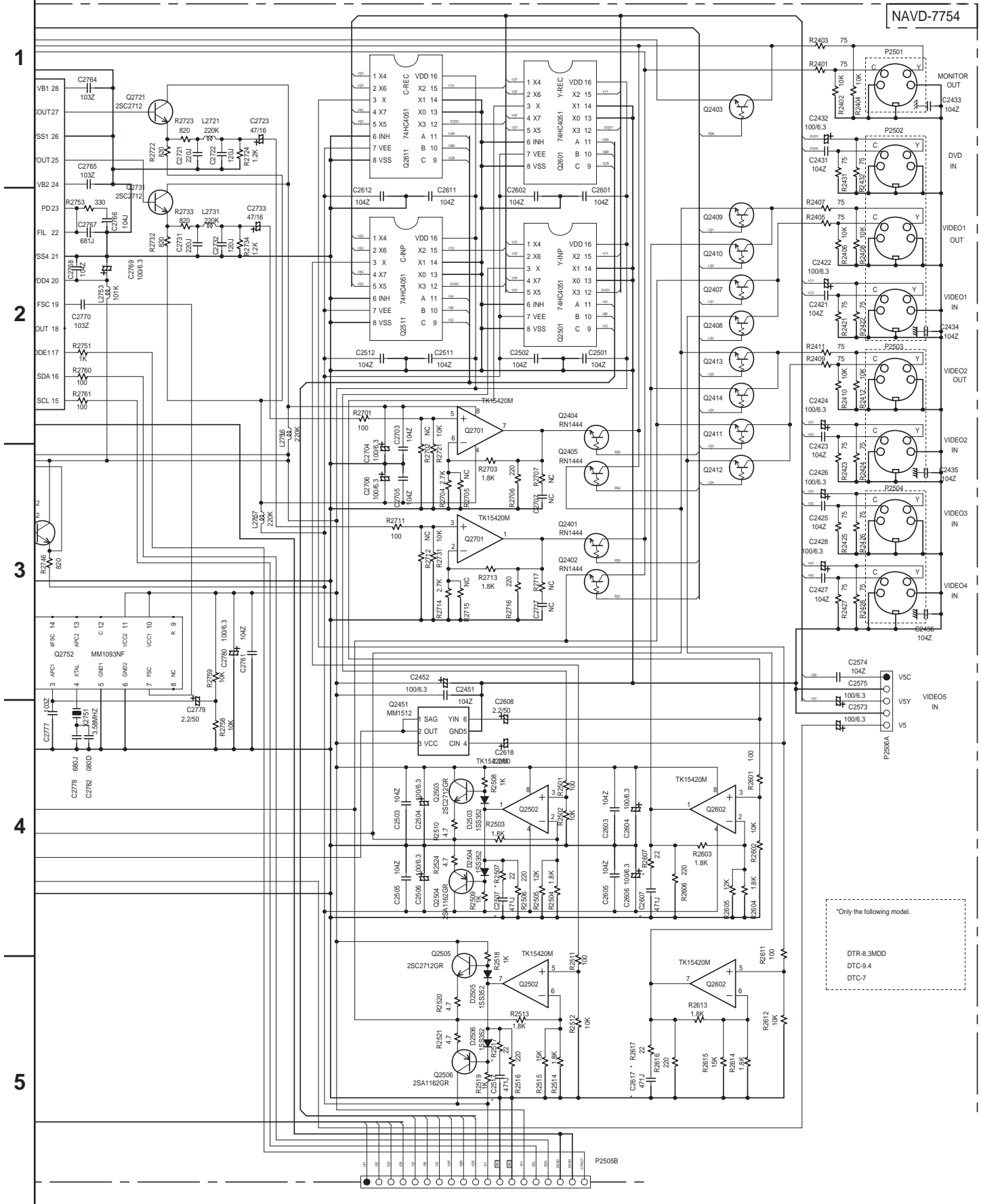

Only the following model.
DTR-8:3MDD
DTC-9.4
DTC-7

**EXPLODED
VIEW PARTS
LIST**

DTA-9.4

REF NO.	PART NAME	DESCRIPTION	PART NO.	NOTE
A001	F BRACKET	.	27111311	
A002	SCREW	3TTB+8B(BC)	838430088	
A003	HOLDER	(BUSHING) TB-1116	27190635	
A005	NUT	.	---	NOT SUPPLY
A006	CHASSIS	.	27100429A	
A007	SCREW	3TTB+8B(BC)	838430088	
A008	CLAMP	WS-2NS	27300833	
A009	HOLDER	KGLS-22RT	27190772	
A010	HOLDER	(BASE-AMP)	27191187A	
A011	HEAT SINK	(AMP)	27160523A	
A012	SCREW	3TTB+8B(BC)	838430088	
A013	SCREW	3TTB+8B(BC)	838430088	
A014	SCREW	3TTB+8B(BC)	838430088	
A016	CAP	(SCREW)	28330135A	
A017	SHLD PLT	.	27150486	
A018	SCREW	3TTW+8B(BC)	831430088	COREx2
A019	SCREW	3P+10FN(BC)	82143010	MAIN PSW
A020	SCREW	3TTB+8B(BC)	838430088	
A021	RETAINER	(TR)	27141868A	
A022	BUSHING	.	28170077	
A023	HEAT SINK	(POW-1)	27160521A	
A024	RETAINER	(HT)	27141832	
A025	SCREW	3TTB+8B(BC)	838430088	A024x6,PCBx6
A026	SCREW	3TTS+16B(BC)	834430168	
A027	SCREW	3SMS8W.SW+14B(BC)	801433	
A030	HEAT SINK	(POW-2)	27160522A	
A031	RETAINER	(HT)	27141832	
A032	SCREW	3TTB+8B(BC)	838430088	A031x6,PCBx6
A035	SCREW	3TTS+16B(BC)	834430168	
A037	SCREW	3SMS8W.SW+14B(BC)	801433	
A038	SCREW	3TTB+8B(BC)	838430088	
A039	SCREW	3TTB+8B(BC)	838430088	3307-12
A041	RETAINER	(BUS-18)	27141852	
A041a	RETAINER	(BUS-18)	27141852-1	
A042	RETAINER	(BUS-19)	27141853	
A043	RETAINER	(BUS-20)	27141854	
A044	SCREW	3TTC+8B(Cu)	---	NOT SUPPLY
A045	SCREW	3TTB+8B	838130088	
A047	HOLDER	(BASE-POW)	27191186	
A049	SCREW	3TTB+10B(BC)	838430108	

A050	SCREW	3TTB+8B(BC)	838430088
A060	RETAINER	(PC)	27141831
A061	SCREW	3TTB+8B(BC)	838430088
A070	HOLDER	(CASE)	27191188
A071	SCREW	3TTB+10B(BC)	838430108
A075	COVER	.	28184852
A076	LABEL	(COVER)	29362772
A077	LABEL	(UD)	29362572A
A078	SCREW	4TTB+8C(BC)	838440089
A080	SCREW	3TTB+8B(BC)	838430088
A081	SCREW	(COVER)	801605
A082	BRACKET	(COVER)	27130907
A083	ADHESIVE	SUPER X	260580
A085	LEG	LEG	27175319B
A086	CUSHION	.	28141494
A087	SCREW	4TTB+8C(BC)	838440089
A401	REAR PANEL	UDD	27123062B
A402	SCREW	3TTB+8B(BC)	838430088
A403	SCREW	4TTB+8C(BC)	838440089
A410	LABEL	HOOKUP-INTEGRA	29363195
A420	F PANEL	UDD	27212464B
A421	SCREW	3TTB+8B(BC)	838430088
A422	END CAP	(L)	28125396
A423	END CAP	(R)	28125397
A424	FACET	(POW)	28198955A
A425	FACET	(STA)	28198956
A426	GUIDE	(POW)	27268064B
A427	BADGE	.	28135278
A430	KNOB	(POW)AS	28326045A
A431	SCREW	3TTB+8B(BC)	838430088
A435	CUSHION	150x100xt10	28141536
A901	WIRE TIE	BINDER(CLAMPER)UL	260208
D101	DIODE	FMG-33S	22380335
D102	DIODE	FMG-33R	22380336
D103	DIODE	FMG-33S	22380335
D104	DIODE	FMG-33R	22380336
D901	DIODE	RBV-2506	22380303
D901 or	DIODE	D25XB60	22380304
D902	TRIAC	SM25GZ51	225415
E112	TRM(SCREW)	NEGITANSI M4	25065640
E113	TRM(SCREW)	NEGITANSI M4	25065640
E114	TRM(SCREW)	NEGITANSI M4	25065640
E173	RETAINER	(BUS-21)	27141855
E173A	SCREW	3TTB+6B	838130068
E174	RETAINER	(BUS-22)	27141856
E174A	SCREW	3TTB+6B	838130068
E175	RETAINER	(BUS-23)	27141857
E175A	SCREW	3TTB+6B	838130068
E806	TRM(SCREW)	NEGITANSI M4	25065640

F901	FUSE	12A-UL/T-314	252196
F9801	FUSE	1A-UL/T-233	252280
F9801 or	FUSE	1A-UL/T-237	252156
L651	CORE	HF70T18X10X10	230970
P001	WIRE TIE	BINDER(CLAMPER)UL	260208
P193A	BUSHING	70	28170071
P193B	BUSHING	70	28170071
P194A	BUSHING	70	28170071
P194B	BUSHING	70	28170071
P195A	BUSHING	70	28170071
P195B	BUSHING	70	28170071
P196A	BUSHING	70	28170071
P651	TRM	NTM-2PMN272	25060341
P891A	BUSHING	70	28170071
P892A	BUSHING	70	28170071
P893A	BUSHING	70	28170071
P894A	BUSHING	70	28170071
P895A	BUSHING	70	28170071
P901	AC CORD	AS-UC-2	253301HIT
P981A	BUSHING	CE-012S L45	28170073
P982A	BUSHING	CE-012S L45	28170073
P983A	BUSHING	70	28170071
P985A	BUSHING	70	28170071
P986A	BUSHING	70	28170071
P987A	BUSHING	70	28170071
P988A	BUSHING	70	28170071
P9904	SOCKET AS	NSAS-2P0903	2009990649
P9908C	CORE	HF70T18X10X10	230970
P990A	BUSHING	70	28170071
Q505	TR	FQP22P10	2203770
Q505B	ISO SHEET	M80 D-2	223037
Q506	TR	FQP33N10	2203780
Q506B	ISO SHEET	M80 D-2	223037
Q511	TR	FQP22P10	2203770
Q511B	ISO SHEET	M80 D-2	223037
Q512	TR	FQP33N10	2203780
Q512B	ISO SHEET	M80 D-2	223037
Q842	TR	2SA1488-G	2203395
Q881	TR	STW26NM50	2203720
Q881A	ISO SHEET	AC238	223024
Q882	TR	STW26NM50	2203720
Q882A	ISO SHEET	AC238	223024
Q883	TR	STW26NM50	2203720
Q883A	ISO SHEET	AC238	223024
Q884	TR	STW26NM50	2203720
Q884A	ISO SHEET	AC238	223024
A620	Cu TAPE	831S W19	29110175
U1	PRIMARY POWER SUPPLY PC BOARD ASSY	NAPS-7788	1A953588-1A

U2	SECONDARY POWER SUPPLY PC BOARD ASSY	NAPS-7789	1A953589-1A
U3	INLET PC BOARD ASSY	NAETC-7801	1A953501-1A
U4	TEMPERATURE SENSOR PC BOARD ASSY	NAETC-7803	1A953503-1A
U5	SWITCHING CONTROL PC BOARD ASSY	NAPS-7790	1A953590-1A
U6	12V TRIGGER TERMINAL PC BOARD ASSY	NAPS-7792	1A953592-1A
U7	CONTROL PC BOARD ASSY	NAPS-7793	1A953593-1A
U8	DISPLAY LED PC BOARD ASSY	NAETC-7794	1A953594-1A
U9	POWER SWITCH PC BOARD ASSY	NASW-7795	1A953595-1A
U10	POWER SWITCH HOLDER PC BOARD ASSY	NAETC-7796	1A953596-1A
U11	TEMPERATURE SENSOR PC BOARD ASSY BOARD	NAETC-7802	1A953502-1A
U12	HOLDER PC BOARD ASSY BOARD	NAETC-7804	1A953504-1A
U14	TERMINAL PC BOARD ASSY	NAPS-7791	1A953591-1A
U15	POWER AMPLIFIER PC BOARD ASSY	NAAF-7797	1A953597-1A
U16	TEMPERATURE SENSOR PC BOARD ASSY BOARD	NAAF-7798	1A953598-1A

PC BOARD PARTS LIST

DTA-9.4

U1 **PRIMARY POWER
SUPPLY PC BOARD** **NAPS-7788-1A**

REF NO.	PART NAME	DESCRIPTION	PART NO.	NOTE
D903	DIODE	D1NL40	22380323	
D904	DIODE	D1NL40	22380323	
D905	DIODE	D1NL40	22380323	
D906	DIODE	D1NL40	22380323	
D907	LED	SEL4110R	225290	
D931	DIODE	1SS133	223163	
D941	DIODE	EK16	22380329F	
D942	DIODE	EK16	22380329F	
D943	DIODE	EK16	22380329F	
D944	DIODE	EK16	22380329F	
L901	CHOKO COIL	NCH-3596	231319	!
L904	CHOKO COIL	NCH-1594	231317180	
L906	CHOKO COIL	NCH-3597	231320	
L912	FR CORE	BL02RN2-R62	230906	
L913	FR CORE	BL02RN2-R62	230906	
L941	CHOKO COIL	NCH-1602	231326A	
P101	CRIMP AS	CRIMP AS	206CC56080UL	
T901	SW TRANS	NSWT-3025	231312	
T902	SW TRANS	NSWT-3025	231312	
C901	IS C	DE1607F103M-KH	3300031S	!
C902	IS C	QETJ5105KRP2CS	3800037S	!
C903	IS C	DE1E3KX152MB5BA	3300062S	!

C904	IS C	DE1E3KX152MB5BA	3300062S	!
C905	IS C	QEX2E104KTP2CS	3800033S	!
C906	CERA C	DE0910-1E102MKX	3300053S	!
C907	CERA C	DE0910-1E102MKX	3300053S	!
C909	ELECT C	CE69W200V1500M(KMQ)	3504385	
C910	ELECT C	CE69W200V1500M(KMQ)	3504385	
C911	ELECT C	CE69W200V1500M(KMQ)	3504385	
C912	ELECT C	CE69W200V1500M(KMQ)	3504385	
C916	FILM C	DADC400V-105J	3800030S	
C917	FILM C	DADC400V-105J	3800030S	
C918	TF C	ECQ-V50V-104J	374721044	!
C922	IS C	DE1B3KX471KB5B	3300061S	
C923	IS C	DE1B3KX471KB5B	3300061S	
C926	TF C	ECQ-B50V-472J	374724724	
R901	RESISTOR	RD1/2SPH-3.3M	4000206S	
R903	CEMENT R	BWR5WJ-4.7	4800076	
R904	METAL O R	RS1/2WBJ-1K	443521024	!
R905	METAL O R	RS1WBJ-270	441622714F	
R909	METAL R	RNU1/2WCJ-0.22	453532294	
R910	METAL R	RNU1/4WJ-2.2	4500171	
R911	NF CARBON R	R25J-100K	415471044	
R912	NF CARBON R	R25J-100K	415471044	
R913	METAL O R	RS1WBJ-100	441621014F	
R914	METAL O R	RS1WBJ-100	441621014F	
R915	METAL O R	RS1WBJ-100	441621014F	
R916	METAL O R	RS1WBJ-100	441621014F	
R917	METAL O R	RS1WBJ-100	441621014F	
R918	METAL O R	RS1WBJ-100	441621014F	
R919	METAL O R	RS1/2WBJ-47	443524704	!
R920	RESISTOR	RD1/2SPH-1M	4000205S	!
R923	METAL O R	RS1/2WBJ-33K	442523334F	
R924	METAL O R	RS1/2WBJ-33K	442523334F	
RL901	RELAY	NRL-1P10A-DC12-140	25065584	PRIMARY !
RL902	RELAY	NRL-1P10A-DC12-140	25065584	PRIMARY !
P801	SOCKET AS	NSAS-4P1085	2009990767UL	!
P902A	PLUG	NPLG-3P84	25055100	
P903A	PLUG	NPLG-3P84	25055100	
P904	PLUG	NPLG-2P83	25055099	VOLTAGE CHECK
P996	CRIMP AS	CRIMP AS	206CC26500UL	
P997	CRIMP AS	CRIMP ZS	206CC26509UL	
E981	RETAINER	(BUS-13)	27141845	
E982	RETAINER	(BUS-11)	27141843	
E983	RETAINER	(BUS-7)	27141839	
E984	RETAINER	(BUS-12)	27141844	
E985A	RETAINER	(BUS-6)	27141838	
E986	RETAINER	(BUS-9)	27141841	
E987	RETAINER	(BUS-6)	27141838	
E988	RETAINER	(BUS-7)	27141839	
E989	RETAINER	(BUS-7)	27141839	
E990	RETAINER	(BUS-7)	27141839	
E991	RETAINER	(BUS-7)	27141839	

U2 SECONDARY PC BOARD

NAPS-7789

REF NO.	PART NAME	DESCRIPTION	PART NO.	NOTE
Q101	TR	2SA992-E	2211793	
Q102	TR	2SC1845-E	2211733	
Q103	PHT CP	TLP421	24120103	

Q134	TR	2SC1815-GR	2211255	
Q135	TR	2SC1845-E	2211733	
Q135 or	TR	2SC1845-F	2211732	
Q136	TR	2SC1815-GR	2211255	
Q137	TR	2SC1845-E	2211733	
Q137 or	TR	2SC1845-F	2211732	
Q138	TR	2SC1845-E	2211733	
Q138 or	TR	2SC1845-F	2211732	
Q161	TR	2SC2458-GR	2212115	
Q162	TR	2SC2458-GR	2212115	
Q163	TR	2SC2458-GR	2212115	
D105	ZENER D	MTZJ5.6B	224470562	
D106	ZENER D	MTZJ5.6B	224470562	
D107	DIODE	1SS133	223163	
D108	DIODE	1SS133	223163	
D133	LED	SEL4110R	225290	REGURATED
D134	ZENER D	MTZJ5.6B	224470562	
D135	ZENER D	MTZJ5.6B	224470562	
D136	LED	SEL4110R	225290	LOW CURRENT PROT
D161	LED	SEL4110R	225290	
D162	DIODE	1SS133	223163	
E101	RETAINER	KANAGU(7-λ)	27141059	
L101	CHOKO COIL	NCH-1605	231330	
L102	CHOKO COIL	NCH-1605	231330	
P108	PLUG	NPLG-3P84	25055100	VOLTAGE CHECK
P131A	SOCKET	NSCT-8P283	25050459	
C103	ELECT C	CE04W35V3900M(LXZ)	3500214	
C104	ELECT C	CE04W35V3900M(LXZ)	3500214	
C105	ELECT C	CE04W35V3900M(LXZ)	3500214	
C106	ELECT C	CE04W35V3900M(LXZ)	3500214	
C132	TF C	ECQ-B50V-47J	374724724	
C133	ELECT C	CE04W16V-47M	354744709	
C134	ELECT C	CE04W100V-100M	352791019S	
C161	TF C	ECQ-B50V-103J	374721034	
C162	TF C	ECQ-B50V-102J	374721024	
C163	ELECT C	CE04W16V-47M	354744709	
R106	METAL R	RNU1/2WCJ-0.22	453532294	
R107	METAL R	RNU1/2WCJ-0.22	453532294	
R108	CARBON R	R16J-4.7K	417344724	
R109	CARBON R	R16J-4.7K	417344724	
R110	CARBON R	R16J-6.8K	417346824	
R111	CARBON R	R16J-6.8K	417346824	
R112	CARBON R	R16J-33K	417343334	
R113	CARBON R	R16J-33K	417343334	
R137	METAL O R	RS1/2WBJ-5.6K	443525624	
R138	CARBON R	R16J-1.2K	417341224	
R139	TRIM R	N06HR1KBE	5210286	VOLTAGE ADJUSTMENT
R140	CARBON R	R16J-470	417344714	
R141	CARBON R	R16J-1K	417341024	
R142	CARBON R	R16J-47K	417344734	
R144	CARBON R	R16J-150	417341514	
R145	CARBON R	R16J-150	417341514	
R146	CARBON R	R16J-110	417341114	
R147	CARBON R	R16J-2.2K	417342224	
R148	METAL O R	RS1/2WBJ-5.6K	443525624	
R149	CARBON R	R16J-4.7K	417344724	
R150	CARBON R	R16J-220	417342214	
R151	METAL O R	RS1/2WBJ-15	443521504	

R152	METAL O R	RS1/2WBJ-15	443521504	
R161	CARBON R	R16J-1.8K	417341824	
R162	CARBON R	R16J-6.8K	417346824	
R164	CARBON R	R16J-1.8K	417341824	
R165	CARBON R	R16J-1.5K	417341524	
R166	CARBON R	R16J-470	417344714	
R169	CARBON R	R16J-1.2K	417341224	
R170	CARBON R	R16J-47K	417344734	
R171	CARBON R	R16J-10K	417341034	
R172	CARBON R	R16J-47K	417344734	
P161	PLUG	NPLG-2P83	25055099	PROT. TEST
P903B	SOCKET	NSCT-3P278	25050454	
E121	TRM(SCREW)	NEGITANSI M3	25065425	
E122	TRM(SCREW)	NEGITANSI M3	25065425	
E123	TRM(SCREW)	NEGITANSI M3	25065425	
E124	TRM(SCREW)	NEGITANSI M3	25065425	
E125	TRM	NTM-1P233(M1969)	25060302	
E126	TRM	NTM-1P233(M1969)	25060302	
E191	RETAINER	(BUS-24)	27141858-1	
E192	RETAINER	(BUS-24)	27141858	
JL132B	WIRE TRAP	NPLG-3P586	25055624	
JL9906B	SOCKET	NSCT-6P98	25050270	

U3	INLET PC BOARD	NAETC-7801		
REF NO.	PART NAME	DESCRIPTION	PART NO.	NOTE
P9911	SOCKET AS	NSAS-4P1084	2009990766UL	
P995	AC INLET	NPLG-2P913	25055960	AC INLET
F901A	FUSE HOLDER	SN5051	250113	
F901B	FUSE HOLDER	SN5051	250113	

U4	TEMPERATURE SENSOR PC BOARD	NAETC-7803		
REF NO.	PART NAME	DESCRIPTION	PART NO.	NOTE
R163	CARBON R	R16J-5.6K	417345624	
JL132A	WIRE HOL	NSCT-3P874	25051087	
R184	THERMISTOR	PTH9M04BD222TS2F333	4000151	

U5	SWITCHING CONTROL PC BOARD	NAPS-7790		
REF NO.	PART NAME	DESCRIPTION	PART NO.	NOTE
Q801	PHT CP	TLP421	24120103	
Q802	TR	2SC3324-GR	2216825R2	
Q803	TR	2SC3324-GR	2216825R2	
Q804	TR	2SA1312-GR	2216835R2	
Q805	TR	2SA1312-GR	2216835R2	
Q806	TR	2SA1312-GR	2216835R2	
Q807	TR	2SC3324-GR	2216825R2	
Q808	TR	2SC3324-GR	2216825R2	
Q809	TR	2SA1312-GR	2216835R2	
Q810	TR	2SA1312-GR	2216835R2	
Q811	TR	2SC3324-GR	2216825R2	
Q812	IC	74HC112(TC74HC112AF)	222741125R20	
Q813	IC	TC74HCU04F	222740046R20	
Q814	IC	TC74HC08AF	222740085R20	
Q815	TR	RN1402	2214470R2	
Q816	TR	RN2402	2214530R2	
Q817	PHT CP	TLP421	24120103	

Q841	TR	2SC2458-GR	2212115
Q843	TR	2SK2599	2203730
Q844	TR	2SC2458-GR	2212115
Q845	TR	2SA992-E	2211793
Q848	IC(REGULATOR)	78M05HF	222780055
Q851	PHT CP	TLP421	24120103
Q852	TR	2SC2120-Y	2211164
Q853	TR	2SC2120-Y	2211164
Q861	TR	2SA950-Y	2211504
Q862	TR	2SC2120-Y	2211164
Q863	TR	2SC2120-Y	2211164
Q864	TR	2SA950-Y	2211504
Q865	TR	2SA950-Y	2211504
Q866	TR	2SC2120-Y	2211164
Q867	TR	2SC2120-Y	2211164
Q868	TR	2SA950-Y	2211504
Q869	TR	2SA950-Y	2211504
Q870	TR	2SC2120-Y	2211164
Q871	TR	2SC2120-Y	2211164
Q872	TR	2SA950-Y	2211504
Q873	TR	2SA950-Y	2211504
Q874	TR	2SC2120-Y	2211164
Q875	TR	2SC2120-Y	2211164
Q876	TR	2SA950-Y	2211504
D801	C-DIODE	1SS355	223269R2
D802	C-DIODE	1SS355	223269R2
D803	C-DIODE	1SS355	223269R2
D804	C-DIODE	1SS355	223269R2
D805	C-DIODE	1SS355	223269R2
D841	ZENER D	MTZJ5.6B	224470562
D842	ZENER D	MTZJ12C	224471203
D843	C-DIODE	SPX-G32S	22380330R2
D844	DIODE	1SS133	223163
D845	ZENER D	MTZJ24D	224472404
D847	DIODE	1SS133	223163
D848	ZENER D	MTZJ24D	224472404
D851	LED	SEL4110R	225290
D861	DIODE	AK04	22380325
D862	DIODE	AK04	22380325
D863	DIODE	AK04	22380325
D864	DIODE	AK04	22380325
D865	DIODE	AK04	22380325
D866	DIODE	AK04	22380325
D867	DIODE	AK04	22380325
D868	DIODE	AK04	22380325
D881	ZENER D	MTZJ10C	224471003
D882	ZENER D	MTZJ10C	224471003
D883	ZENER D	MTZJ10C	224471003
D884	ZENER D	MTZJ10C	224471003
D885	ZENER D	MTZJ10C	224471003
D886	ZENER D	MTZJ10C	224471003
D887	ZENER D	MTZJ10C	224471003
D888	ZENER D	MTZJ10C	224471003
D889	DIODE	RL2	22380324F
D890	DIODE	RL2	22380324F
D891	DIODE	RL2	22380324F
D892	DIODE	RL2	22380324F
D893	C-DIODE	SFPB-76	22380328R2
D894	C-DIODE	SFPB-76	22380328R2

THI PROT.

D895	C-DIODE	SFPB-76	22380328R2
D896	C-DIODE	SFPB-76	22380328R2
L881	CHOKE COIL	NCH-0604	231329R2
L902	CHOKE COIL	NCH-1600	231323
L903	CHOKE COIL	NCH-1600	231323
T851	SW TRANS	NSWT-3026	231324A
T852	SW TRANS	NSWT-3026	231324A
T853	SW TRANS	NSWT-3026	231324A
T854	SW TRANS	NSWT-3026	231324A
C801	C-CERA C	CK725F1E-104Z1	332161040R1
C802	TF C	ECQ-B50V-471J	374724714
C803	C-CERA C	CC725CH1H-330J1	342103304R1
C804	C-CERA C	CC725CH1H-330J1	342103304R1
C805	C-CERA C	CC725CH1H-100D1	342101002R1
C806	TF C	ECQ-B50V-121K	374721215
C807	C-CERA C	CC725CH1H-101J1	342101014R1
C808	C-CERA C	CC725CH1H-150J1	342101504R1
C809	C-CERA C	CK725F1E-104Z1	332161040R1
C811	ELECT C	CE04W16V-47M	354744709
C812	ELECT C	CE04W16V-220M	354742219
C813	TF C	ECQ-B50V-271K	374722715
C814	ELECT C	CE04W50V-1M	354780109
C841	ELECT C	CE04W35V-470M	354764719S
C842	ELECT C	CE04W16V-47M	354744709
C843	ELECT C	CE04W35V-22M	354762209
C845	ELECT C	CE04W50V-47M	354784709
C846	ELECT C	CE04W50V-1M	354780109
C847	ELECT C	CE04W50V-1M	354780109
C851	ELECT C	CE04W16V-10M	354741009
C852	TF C	ECQ-B50V-103J	374721034
C853	ELECT C	CE04W50V-1M	354780109
C861	ELECT C	CE04W35V-330M	354763319S
C862	TF C	ECQ-V50V-104J	374721044
C863	ELECT C	CE04W16V-22M	354742209
C864	TF C	ECQ-V50V-104J	374721044
C865	ELECT C	CE04W16V-22M	354742209
C866	ELECT C	CE04W35V-330M	354763319S
C867	TF C	ECQ-V50V-104J	374721044
C868	ELECT C	CE04W16V-22M	354742209
C869	ELECT C	CE04W16V-22M	354742209
C870	TF C	ECQ-V50V-104J	374721044
C881	FILM C	DADC250V-225J	3800031S
C882	FILM C	DADC250V-225J	3800031S
C891	IS C	DE1B3KX471KB5B	3300061S
C892	FILM C	DLDA1250V-222H	3800032S
C920	IS C	QETJ5104KRP2CS	3800036S
R801	C-CARBON R	RN72K1J-103JE	435031034R1
R802	C-CARBON R	RN72K1J-681JE	435036814R1
R803	C-CARBON R	RN72K1J-562JE	435035624R1
R804	C-CARBON R	RN72K1J-152JE	435031524R1
R805	C-CARBON R	RN72K1J-152JE	435031524R1
R806	C-CARBON R	RN72K1J-181JE	435031814R1
R807	C-CARBON R	RN72K1J-123JE	435031234R1
R808	C-CARBON R	RN72K1J-153JE	435031534R1
R809	C-CARBON R	RN72K1J-153JE	435031534R1
R810	C-CARBON R	RN72K1J-123JE	435031234R1
R811	C-CARBON R	RN72K1J-472JE	435034724R1
R812	C-CARBON R	RN72K1J-183JE	435031834R1
R813	C-CARBON R	RN72K1J-680JE	435036804R1

!
!

!

R814	C-CARBON R	RN72K1J-000JE	435030004R1	
R815	C-CARBON R	RN72K1J-000JE	435030004R1	
R816	C-CARBON R	RN72K1J-103JE	435031034R1	
R817	C-CARBON R	RN72K1J-472JE	435034724R1	
R818	C-CARBON R	RN72K1J-472JE	435034724R1	
R819	C-CARBON R	RN72K1J-103JE	435031034R1	
R820	C-CARBON R	RN72K1J-682JE	435036824R1	
R821	C-CARBON R	RN72K1J-273JE	435032734R1	
R822	C-CARBON R	RN72K1J-100JE	435031004R1	
R823	C-CARBON R	RN72K1J-100JE	435031004R1	
R824	C-CARBON R	RN72K1J-100JE	435031004R1	
R825	C-CARBON R	RN72K1J-100JE	435031004R1	
R827	C-CARBON R	RN72K1J-152JE	435031524R1	
R841	CARBON R	R16J-2.2K	417342224	
R842	METAL O R	RS1WBJ-470	441624714F	
R843	CARBON R	R16J-82K	417348234	
R844	CARBON R	R16J-47K	417344734	
R845	CARBON R	R16J-1K	417341024	
R846	CARBON R	R16J-47K	417344734	
R847	CARBON R	R16J-4.7K	417344724	
R848	THERMISTOR	PTGL05AR151H8P52B0	4000214	!
R849	METAL O R	RS1/2WBJ-56K	442525634F	
R851	CARBON R	R16J-8.2K	417348224	
R852	CARBON R	R16J-6.8K	417346824	
R853	CARBON R	R16J-470	417344714	
R855	CARBON R	R16J-1K	417341024	
R859	METAL O R	RS1/2WBJ-33	443523304	
R861	THERMISTOR	PTGL05AR151H8P52B0	4000214	!
R862	METAL O R	RS1WBJ-470	441624714F	
R871	C-CARBON R	RN72K1J-100JE	435031004R1	
R872	C-CARBON R	RN72K1J-100JE	435031004R1	
R873	C-CARBON R	RN72K1J-100JE	435031004R1	
R874	C-CARBON R	RN72K1J-100JE	435031004R1	
R875	METAL R	RNU1/2WCJ-0.47	453534794	
R876	METAL R	RNU1/2WCJ-0.47	453534794	
R881	METAL O R	RS1/2WBJ-10	442521004F	
R882	METAL O R	RS1/2WBJ-10	442521004F	
R883	METAL O R	RS1/2WBJ-10	442521004F	
R884	METAL O R	RS1/2WBJ-10	442521004F	
R891	METAL O R	RS1/2WBJ-68	442526804F	
R892	METAL O R	RS1/2WBJ-68	442526804F	
R893	METAL O R	RS1/2WBJ-68	442526804F	
R894	METAL O R	RS1/2WBJ-68	442526804F	
R895	METAL R	RNU1/2WCJ-0.47	452534794F	
P803A	SOCKET	NSCT-8P283	25050459	
P902B	SOCKET	NSCT-3P278	25050454	
E881	RETAINER	KANAGU(7-λ)	27141059	
E891	RETAINER	(BUS-10)	27141842	
E892	RETAINER	(BUS-16)	27141848	
E893	RETAINER	(BUS-14)	27141846	
E894	RETAINER	(BUS-15)	27141847	
E895	RETAINER	(BUS-17)	27141849	
JL805B	WIRE TRAP	NPLG-3P586	25055624	
R181	THERMISTOR	PTH9M04BE222TS2F333	4000152	

U6 12V TRIGGER NAPS-7792
TERMINAL PC BOARD

REF NO.	PART NAME	DESCRIPTION	PART NO.	NOTE
P9908A	SOCKET AS	NSAS-10P0236	2002391030	
P9910	ST JACK	LGS6506-0200C	25045667	12V TRIGGER
E9902	TRM(SCREW)	NEGITANSI M3	25065425	
E9903	TRM(SCREW)	NEGITANSI M3	25065425	

U7 CONTROL PC BOARD NAPS-7793

REF NO.	PART NAME	DESCRIPTION	PART NO.	NOTE
FT9801	PHT CP	TLP521-2GB	24120002	
Q9801	TR	2SA965-Y	2211644	
Q9802	TR	RN1401	2214460R2	
Q9803	IC	TC74HC00AF	222740005R2O	
Q9804	IC(REGULATOR)	78M05HF	222780055	
Q9805	PHT CP	TLP421	24120103	
Q9806	IC	TC74HC123AF	222741235R2O	
Q9807	TR	RN1402	2214470R2	
Q9808	IC	M51957BFP	22241239R2	
Q9809	TR	RN1404	2214490R2	
Q9810	TR	RN1404	2214490R2	
Q9811	TR	2SA950-Y	2211504	
Q9813	TR	RN2402	2214530R2	
Q9814	TR	RN1403	2214480R2	
Q9815	TR	RN1402	2214470R2	
Q9816	TR	RN2404	2214550R2	
Q9817	IC	TC7W74FU	22241408R2	
Q9818	TR	RN2404	2214550R2	
Q9819	TR	RN1402	2214470R2	
Q9820	TR	2SA950-Y	2211504	
Q9821	TR	RN1402	2214470R2	
Q9822	IC	TC7W14FU	22241161R2	
Q9823	TR	RN2404	2214550R2	
Q9824	TR	RN1402	2214470R2	
Q9825	IC	TC7S08FU	22241172R2	
Q9826	TR	RN1402	2214470R2	
Q9827	IC	TC74HC123AF	222741235R2O	
Q9828	TR	2SK3018	2216010R2	
Q9829	IC	TC7S08FU	22241172R2	
Q9830	TR	2SK3018	2216010R2	
Q9831	TR	RN1402	2214470R2	
Q9832	TR	RN1402	2214470R2	
Q9833	TR	RN2404	2214550R2	
D9801	DIODE	AM01Z	22380046	
D9802	DIODE	AM01Z	22380046	
D9803	DIODE	AM01Z	22380046	
D9804	DIODE	AM01Z	22380046	
D9805	LED	SEL4110R	225290	POWER SUPPLY WARNING
D9806	C-DIODE	1SS355	223269R2	
D9807	C-DIODE	1SS355	223269R2	
D9808	C-DIODE	1SS355	223269R2	
D9809	C-DIODE	1SS355	223269R2	
D9810	C-DIODE	1SS355	223269R2	
D9811	C-DIODE	1SS355	223269R2	

D9814	C-DIODE	1SS355	223269R2
D9815	C-DIODE	1SS355	223269R2
D9816	DIODE	1SS133	223163
D9817	C-DIODE	1SS355	223269R2
D9818	C-DIODE	1SS355	223269R2
D9819	DIODE	AM01Z	22380046
D9820	DIODE	AM01Z	22380046
D9821	C-DIODE	1SS355	223269R2
D9822	C-DIODE	1SS355	223269R2
T9801	P TRANS	NPT-1461D	2301672
L942	CORE	NFY-25 BLACK	230945
L998	CORE	NFY-25 BLACK	230945
C9801	IS C	DE1310E472M-KH	3300054
C9802	TF C	ECQ-B50V-103J	374721034
C9803	TF C	ECQ-B50V-103J	374721034
C9804	TF C	ECQ-B50V-103J	374721034
C9805	ELECT C	CE04W25V-2200M(VZ)	394552227S
C9806	ELECT C	CE04W16V-47M	354744709
C9807	TF C	ECQ-V50V-104J	374721044
C9808	ELECT C	CE04W50V-1M	354780109
C9809	ELECT C	CE04W50V-1M	354780109
C9810	TF C	ECQ-V50V-104J	374721044
C9811	ELECT C	CE04W35V-22M	354762209
C9812	TF C	ECQ-V50V-104J	374721044
C9813	VX C	CE04W16V-47M(VX)	393344707
C9814	TF C	ECQ-B50V-102J	374721024
C9815	ELECT C	CE04W50V-4.7M	354780479
C9816	ELECT C	CE04W16V-10M	354741009
C9817	ELECT C	CE04W6.3V-220M	354722219
C9818	TF C	ECQ-B50V-102J	374721024
C9820	TF C	ECQ-V50V-104J	374721044
C9821	TF C	ECQ-V50V-104J	374721044
R9801	METAL O R	RS1/2WBJ-0.47	443534794
R9803	C-CARBON R	RN72K1J-222JE	435032224R1
R9804	C-CARBON R	RN72K1J-222JE	435032224R1
R9805	CARBON R	R16J-470	417344714
R9806	C-CARBON R	RN72K1J-104JE	435031044R1
R9807	C-CARBON R	RN72K1J-104JE	435031044R1
R9808	C-CARBON R	RN72K1J-105JE	435031054R1
R9809	C-CARBON R	RN72K1J-105JE	435031054R1
R9810	C-CARBON R	RN72K1J-103JE	435031034R1
R9811	C-CARBON R	RN72K1J-272JE	435032724R1
R9812	C-CARBON R	RN72K1J-221JE	435032214R1
R9813	METAL O R	RS2WBJ-150	441721514F
R9814	C-CARBON R	RN72K1J-102JE	435031024R1
R9815	C-CARBON R	RN72K1J-102JE	435031024R1
R9816	C-CARBON R	RN72K1J-103JE	435031034R1
R9817	CARBON R	R16J-180	417341814
R9818	CARBON R	R16J-180	417341814
R9819	C-CARBON R	RN72K1J-103JE	435031034R1
R9820	C-CARBON R	RN72K1J-152JE	435031524R1
R9821	C-CARBON R	RN72K1J-103JE	435031034R1
R9822	C-CARBON R	RN72K1J-103JE	435031034R1
R9823	C-CARBON R	RN72K1J-152JE	435031524R1
R9824	METAL O R	RS2WBJ-150	441721514F
R9825	C-CARBON R	RN72K1J-221JE	435032214R1
R9826	C-CARBON R	RN72K1J-152JE	435031524R1
R9827	C-CARBON R	RN72K1J-563JE	435035634R1
R9828	C-CARBON R	RN72K1J-103JE	435031034R1

!

!

R9829	C-CARBON R	RN72K1J-394JE	435033944R1
R9830	C-CARBON R	RN72K1J-105JE	435031054R1
R9831	C-CARBON R	RN72K1J-473JE	435034734R1
R9832	C-CARBON R	RN72K1J-103JE	435031034R1
R9833	C-CARBON R	RN72K1J-103JE	435031034R1
R9835	C-CARBON R	RN72K1J-105JE	435031054R1
R9836	C-CARBON R	RN72K1J-472JE	435034724R1
R9837	C-CARBON R	RN72K1J-103JE	435031034R1
R9839	C-CARBON R	RN72K1J-473JE	435034734R1
R9840	C-CARBON R	RN72K1J-103JE	435031034R1
R9841	C-CARBON R	RN72K1J-103JE	435031034R1
R9842	C-CARBON R	RN72K1J-103JE	435031034R1
P801C	PLUG	NPLG-3P1113	25056174
P9904A	PLUG	NPLG-2P631	25055675
P9907B	PLUG	NPLG-3P131	25055147
P9908B	PLUG	NPLG-5P133	25055149
P9909	PLUG	NPLG-7P135	25055151
P9911C	PLUG	NPLG-2P631	25055675
P9912	HOLDER	(CRAMP) UA-0 V0	27190608-1
P998	HOLDER	(CRAMP) UA-0 V0	27190608-1
E9901	TRM	NTM-1P233(M1969)	25060302
F9801A	FUSE HOL	NSCT-1P2031	25052133
F9801B	FUSE HOL	NSCT-1P2031	25052133
JL9906A	WIRE HOL	NSCT-6P897	25051110

U8 DISPLAY LED PC NAETC-7794
BOARD

REF NO.	PART NAME	DESCRIPTION	PART NO.	NOTE
D9812	LED	SDLB30D0	225417	POWER
D9812A	HOLDER	(LED)	27191018A	LED HOLDER
D9813	LED	SLR-332VR(h1=8mm)	225338	STANDBY/ WARNING
P9907A	SOCKET AS	NSAS-6P1082	2002A390625	

U9 POWER SWITCH PC NAPS-7796
BOARD

REF NO.	PART NAME	DESCRIPTION	PART NO.	NOTE
C9850	IS C	DE1610F103M-KH	3300055	!
S9801	P SW	NPS-111-L512P	25035550	POWER
P9904	SOCKET AS	NSAS-2P0903	2009990649	

U11 TEMPERATURE NAETC-7802
SENSOR PC BOARD

REF NO.	PART NAME	DESCRIPTION	PART NO.	NOTE
R854	THERMISTOR	PTH9M04BD222TS2F333	4000151	
JL805A	WIRE HOL	NSCT-3P874	25051087	

U14 TERMINAL PC BOARD NAPS-7791

REF NO.	PART NAME	DESCRIPTION	PART NO.	NOTE
P131B	PLUG	NPLG-8P89	25055105	
P803B	PLUG	NPLG-8P89	25055105	

U15 POWER AMPLIFIER NAAF-7797
PC BOARD

REF NO.	PART NAME	DESCRIPTION	PART NO.	NOTE
Q301	IC	NJM4565M-D	22241383R2	
Q302	IC	NJM5532M-D	22241449R2	

Q303	IC	NJM4565M-D	22241383R2
Q401	TR	2SA1162-GR	2214375R2
Q402	TR	RN2402	2214530R2
Q403	TR	2SA1162-GR	2214375R2
Q404	TR	2SA1162-GR	2214375R2
Q405	TR	2SA1462-Y34	2216792R2
Q406	TR	2SA1462-Y34	2216792R2
Q407	TR	2SC3735-Y34	2216802R2
Q408	TR	2SC3735-Y34	2216802R2
Q501	TR	2SA1462-Y34	2216792R2
Q502	TR	2SC3735-Y34	2216802R2
Q503	TR	2SC3733-L	2216772
Q504	TR	2SA1460-L	2216782
Q507	TR	2SA1462-Y34	2216792R2
Q508	TR	2SC3735-Y34	2216802R2
Q509	TR	2SC3733-L	2216772
Q510	TR	2SA1460-L	2216782
Q513	TR	2SC1622A(D18)	2216154R2
Q514	TR	2SC1622A(D18)	2216154R2
Q515	TR	2SA1162-GR	2214375R2
Q517	TR	2SC1622A(D18)	2216154R2
Q518	TR	2SC1622A(D18)	2216154R2
Q580	IC	NJM4565M-D	22241383R2
Q581	IC	NJM4565M-D	22241383R2
Q601	IC(REGULATOR)	NJM78M15FA	222780155JRC
Q602	IC(REGULATOR)	NJM79M15FA	222790155JRC
Q603	IC(REGULATOR)	78M07HF	222780075
Q603A	HEAT SINK	RAD-184	27160528
Q603B	SCREW	3P+10FN(BC)	82143010
Q604	IC(REGULATOR)	79M07HF	222790075
Q604B	SCREW	3P+10FN(BC)	82143010
Q605	TR	2SA1930	2203000
Q606	TR	2SC5171	2203010
Q607	TR	2SC2712-GR	2213145R2
Q608	TR	2SA1162-GR	2214375R2
Q610	IC(REGULATOR)	78L05	222780053
Q701	IC	TC74HC14AF	222740145R2O
Q702	TR	RN1402	2214470R2
Q704	IC	TC7W74FU	22241408R2
Q705	TR	RN2402	2214530R2
Q706	TR	RN1404	2214490R2
Q707	TR	RN2402	2214530R2
Q708	TR	2SA965-Y	2211644
Q709	TR	2SC2712-GR	2213145R2
Q711	PHT CP	TLP521-2GB	24120002
Q713	TR	RN1402	2214470R2
Q714	TR	RN1402	2214470R2
Q715	TR	2SA1162-GR	2214375R2
Q716	TR	2SC1622A(D18)	2216154R2
Q717	PHT CP	TLP521-2GB	24120002
Q718	TR	RN1402	2214470R2
Q719	TR	RN1404	2214490R2
Q751	IC	TC7S14F	22241175R2
Q752	IC	TC7W74FU	22241408R2
Q753	TR	RN1402	2214470R2
Q754	TR	RN1402	2214470R2
D401	ZENER D	UDZS5.6B	224550560R2
D501	ZENER D	UDZS15B	224551500R2
D502	ZENER D	UDZS15B	224551500R2

D503	ZENER D	UDZS15B	224551500R2	
D504	ZENER D	UDZS15B	224551500R2	
D505	C-DIODE	EC21QS10	22380334R2	
D506	C-DIODE	EC21QS10	22380334R2	
D507	ZENER D	UDZS15B	224551500R2	
D508	ZENER D	UDZS15B	224551500R2	
D509	ZENER D	UDZS15B	224551500R2	
D510	ZENER D	UDZS15B	224551500R2	
D511	C-DIODE	EC21QS10	22380334R2	
D512	C-DIODE	EC21QS10	22380334R2	
D513	C-DIODE	1SS355	223269R2	
D514	C-DIODE	1SS355	223269R2	
D515	ZENER D	UDZS30B	224553000R2	
D516	ZENER D	UDZS30B	224553000R2	
D517	C-DIODE	1SS355	223269R2	
D518	C-DIODE	1SS355	223269R2	
D580	C-DIODE	1SS355	223269R2	
D581	C-DIODE	1SS355	223269R2	
D601	ZENER D	UDZS3.6B	224550360R2	
D602	ZENER D	UDZS3.6B	224550360R2	
D703	C-DIODE	1SS355	223269R2	
D704	C-DIODE	1SS355	223269R2	
D705	LED	SEL2110R-TP6	225389	DC OUTPUT WARNING
D706	C-DIODE	1SS355	223269R2	
D707	ZENER D	UDZS5.1B	224550510R2	
D708	C-DIODE	1SS355	223269R2	
D709	C-DIODE	1SS355	223269R2	
D710	LED	SEL2910A-TP6	225390	MODULATOR OPERATION OVER TEMP/ CURRENT WARNING
D751	LED	SEL2110R-TP6	225389	
L501	CHOKE COIL	NCH-1470	231237M015R2	
L502	CHOKE COIL	NCH-1470	231237M015R2	
L503	CHOKE COIL	NCH-1470	231237M015R2	
L504	CHOKE COIL	NCH-1470	231237M015R2	
L505	CHOKE COIL	NCH-1590	231313120	
L506	CHOKE COIL	NCH-1590	231313120	
L507	CHOKE COIL	NCH-1607	231332	
L601	CHOKE COIL	NCH-1591	231314330	
L602	CHOKE COIL	NCH-1591	231314330	
C301	TF C	ECQ-B50V-681J	374726814	
C302	TF C	ECQ-B50V-681J	374726814	
C303	VX C	CE04W50V-47M(VX)	393384707	
C304	VX C	CE04W50V-47M(VX)	393384707	
C305	VX C	CE04W50V-47M(VX)	393384707	
C306	TF C	ECQ-B50V-331K	374723315	
C307	TF C	ECQ-B50V-331K	374723315	
C308	VX C	CE04W16V-220M(VX)	393342217	
C309	VX C	CE04W16V-220M(VX)	393342217	
C310	VX C	CE04W16V-220M(VX)	393342217	
C311	VX C	CE04W16V-220M(VX)	393342217	
C312	TF C	ECQ-B50V-681J	374726814	
C313	VX C	CE04W50V-100M(VX)	393381017	
C314	VX C	CE04W50V-100M(VX)	393381017	
C315	VX C	CE04W50V-47M(VX)	393384707	
C316	VX C	CE04W50V-47M(VX)	393384707	
C401	VX C	CE04W16V-22M(VX)	393342207	

C402	TF C	ECQ-B50V-102J	374721024
C403	TF C	ECQ-B50V-102J	374721024
C404	TF C	ECQ-B50V-102J	374721024
C405	TF C	ECQ-B50V-102J	374721024
C408	TF C	ECQ-V50V-104J	374721044
C409	TF C	ECQ-V50V-104J	374721044
C410	ELECT C	CE04W6.3V-220M(PW)	393722217
C411	ELECT C	CE04W6.3V-220M(PW)	393722217
C412	TF C	ECQ-B50V-101K	374721015
C413	TF C	ECQ-B50V-101K	374721015
C501	VX C	CE04W16V-470M(VX)	393344717
C502	VX C	CE04W16V-470M(VX)	393344717
C503	TF C	ECQ-B50V-121K	374721215
C504	TF C	ECQ-B50V-121K	374721215
C505	VX C	CE04W63V-22M(VX)	393372207
C506	VX C	CE04W63V-22M(VX)	393372207
C507	VX C	CE04W16V-100M(VX)	393341017
C508	VX C	CE04W16V-100M(VX)	393341017
C509	TF C	ECQ-V50V-273J	374722734
C510	VX C	CE04W16V-470M(VX)	393344717
C511	VX C	CE04W16V-470M(VX)	393344717
C512	TF C	ECQ-B50V-121K	374721215
C513	TF C	ECQ-B50V-121K	374721215
C514	VX C	CE04W63V-22M(VX)	393372207
C515	VX C	CE04W63V-22M(VX)	393372207
C516	VX C	CE04W16V-100M(VX)	393341017
C517	VX C	CE04W16V-100M(VX)	393341017
C518	TF C	ECQ-V50V-273J	374722734
C519	PLA C	ECQE250V-824J	3700078S
C520	PLA C	ECQE250V-824J	3700078S
C521	PLA C	ECQE250V-153J	3700077S
C522	TF C	ECQ-B50V-123J	374721234
C523	TF-C	ECQ-B100-101K	374731015
C524	TF-C	ECQ-B100-101K	374731015
C525	TF-C	ECQ-B100-101K	374731015
C526	TF-C	ECQ-B100-101K	374731015
C529	TF C	ECQ-B100V-681J	374736814
C530	TF C	ECQ-B100V-681J	374736814
C531	TF C	ECQ-B100V-681J	374736814
C532	TF C	ECQ-B100V-681J	374736814
C534	TF C	ECQ-V50V-334J	374723344
C535	TF C	ECQ-V50V-334J	374723344
C580	TF C	ECQ-V50V-474J	374724744
C581	TF C	ECQ-V50V-105J	374721054
C582	TF C	ECQ-V50V-474J	374724744
C583	VX C	CE04W16V-47M(VX)	393344707
C584	VX C	CE04W16V-47M(VX)	393344707
C586	PLA C	ECQE250V-104K	3700081
C587	JMP WIRE	TA050	78002
C601	ELECT C	CE69W35V-10000M	3504387
C602	ELECT C	CE69W35V-10000M	3504387
C603	TF C	ECQ-V50V-105J	374721054
C604	TF C	ECQ-V50V-105J	374721054
C605	ELECT C	CE04W50V-0.47M	354784799
C606	ELECT C	CE04W50V-0.47M	354784799
C607	PW C	CE04W16V-10M(PW)	393741007
C608	PW C	CE04W16V-10M(PW)	393741007
C609	PW C	CE04W6.3V-100M(PW)	393721017
C610	PW C	CE04W6.3V-100M(PW)	393721017

C611	TF C	ECQ-V50V-105J	374721054
C612	TF C	ECQ-V50V-105J	374721054
C613	VX C	CE04W16V-10M(VX)	393341007
C614	VX C	CE04W16V-10M(VX)	393341007
C616	VX C	CE04W50V-10M(VX)	393381007
C617	VX C	CE04W50V-10M(VX)	393381007
C618	VX C	CE04W50V-10M(VX)	393381007
C701	VX C	CE04W16V-47M(VX)	393344707
C703	VX C	CE04W50V-1M(VX)	393380107
C705	TF C	ECQ-V50V-104J	374721044
C706	C-CERA C	CK725B1H-103K1	332101035R1
C707	C-CERA C	CK725F1E-104Z1	332161040R1
C708	C-CERA C	CK725F1E-104Z1	332161040R1
C751	VX C	CE04W16V-10M(VX)	393341007
C752	C-CERA C	CK725F1E-104Z1	332161040R1
R301	CARBON R	R16J-120	417341214
R302	CARBON R	R16J-120	417341214
R303	CARBON R	R16J-100	417341014
R304	CARBON R	R16J-100	417341014
R305	CARBON R	R16J-10K	417341034
R306	CARBON R	R16J-10K	417341034
R307	CARBON R	R16J-10K	417341034
R308	CARBON R	R16J-10K	417341034
R309	CARBON R	R16J-33K	417343334
R310	CARBON R	R16J-33K	417343334
R311	CARBON R	R16J-4.7K	417344724
R312	CARBON R	R16J-10K	417341034
R314	CARBON R	R16J-10K	417341034
R315	CARBON R	R16J-3.9K	417343924
R316	CARBON R	R16J-10K	417341034
R317	CARBON R	R16J-10K	417341034
R318	CARBON R	R16J-10K	417341034
R319	CARBON R	R16J-10K	417341034
R320	CARBON R	R16J-33K	417343334
R321	CARBON R	R16J-33K	417343334
R322	CARBON R	R16J-100K	417341044
R323	CARBON R	R16J-10K	417341034
R325	CARBON R	R16J-10K	417341034
R326	CARBON R	R16J-3.9K	417343924
R327	METAL O R	RS1/2WBJ-22	443522204
R328	METAL O R	RS1/2WBJ-22	443522204
R329	METAL O R	RS1/2WBJ-22	443522204
R330	METAL O R	RS1/2WBJ-22	443522204
R331	FR CORE	BL02RN1-R62	230905
R334	CARBON R	R16J-120	417341214
R335	CARBON R	R16J-100	417341014
R336	CARBON R	R16J-10K	417341034
R337	CARBON R	R16J-10K	417341034
R338	CARBON R	R16J-10K	417341034
R339	CARBON R	R16J-33K	417343334
R340	CARBON R	R16J-33K	417343334
R341	CARBON R	R16J-100K	417341044
R342	CARBON R	R16J-100	417341014
R343	JMP WIRE	TA050	78002
R344	JMP WIRE	TA050	78002
R401	CARBON R	R16J-4.7K	417344724
R402	CARBON R	R16J-4.7K	417344724
R403	CARBON R	R16J-47K	417344734
R404	CARBON R	R16J-47K	417344734

TA5

R405	CARBON R	R16J-33	417343304	
R406	CARBON R	R16J-33	417343304	
R407	CARBON R	R16J-560	417345614	
R408	C-CARBON R	RN72K1J-104JE	435031044R1	
R409	CARBON R	R16J-5.6K	417345624	
R410	CARBON R	R16J-200	417342014	
R411	CARBON R	R16J-200	417342014	
R412	C-CARBON R	RN72K1J-100JE	435031004R1	
R413	C-CARBON R	RN72K1J-100JE	435031004R1	
R414	C-CARBON R	RN72K1J-223JE	435032234R1	
R415	C-CARBON R	RN72K1J-223JE	435032234R1	
R416	C-CARBON R	RN72K1J-332JE	435033324R1	
R417	C-CARBON R	RN72K1J-332JE	435033324R1	
R418	C-CARBON R	RN72K1J-100JE	435031004R1	
R419	C-CARBON R	RN72K1J-100JE	435031004R1	
R430	TRIM R	N06HR100BE	5210280	DC OFFSET ADJ.
R501	CARBON R	R16J-390	417343914	
R502	CARBON R	R16J-390	417343914	
R503	CARBON R	R16J-560	417345614	
R504	CARBON R	R16J-560	417345614	
R505	CARBON R	R16J-56	417345604	
R506	CARBON R	R16J-56	417345604	
R510	CARBON R	R16J-2.2	417340224	
R511	CARBON R	R16J-2.2	417340224	
R512	CARBON R	R16J-1K	417341024	
R513	CARBON R	R16J-1K	417341024	
R514	CARBON R	R16J-2.2	417340224	
R515	CARBON R	R16J-10	417341004	
R516	METAL PR	BPR55FJ0.047	4500315	
R517	METAL PR	BPR55FJ0.047	4500315	
R518	CARBON R	R16J-8.2K	417348224	
R519	CARBON R	R16J-12K	417341234	
R520	CARBON R	R16J-390	417343914	
R521	CARBON R	R16J-390	417343914	
R522	CARBON R	R16J-560	417345614	
R523	CARBON R	R16J-560	417345614	
R524	CARBON R	R16J-56	417345604	
R525	CARBON R	R16J-56	417345604	
R529	CARBON R	R16J-2.2	417340224	
R530	CARBON R	R16J-2.2	417340224	
R531	CARBON R	R16J-1K	417341024	
R532	CARBON R	R16J-1K	417341024	
R533	CARBON R	R16J-2.2	417340224	
R534	CARBON R	R16J-10	417341004	
R537	CARBON R	R16J-8.2K	417348224	
R538	CARBON R	R16J-12K	417341234	
R539	METAL O R	RS2WBJ-27	441722704F	
R540	C-CARBON R	RN72K1J-274JE	435032744R1	
R541	C-CARBON R	RN72K1J-123JE	435031234R1	
R542	CARBON R	R16J-22K	417342234	
R543	CARBON R	R16J-22K	417342234	
R544	CARBON R	R16J-22K	417342234	
R545	CARBON R	R16J-22K	417342234	
R546	CARBON R	R16J-33K	417343334	
R547	CARBON R	R16J-33K	417343334	
R548	CARBON R	R16J-100K	417341044	
R549	CARBON R	R16J-100K	417341044	
R550	CARBON R	R16J-100K	417341044	
R551	CARBON R	R16J-100K	417341044	

R554	METAL O R	RS1WBJ-15	443621504
R555	METAL O R	RS1WBJ-15	443621504
R556	METAL O R	RS1WBJ-15	443621504
R557	METAL O R	RS1WBJ-15	443621504
R558	CARBON R	R16J-6.8K	417346824
R559	CARBON R	R16J-22K	417342234
R560	CARBON R	R16J-6.8K	417346824
R561	CARBON R	R16J-22K	417342234
R580	CARBON R	R16J-100K	417341044
R581	CARBON R	R16J-100K	417341044
R582	CARBON R	R16J-47K	417344734
R583	CARBON R	R16J-47K	417344734
R584	CARBON R	R16J-220K	417342244
R585	CARBON R	R16J-220K	417342244
R586	CARBON R	R16J-1M	417341054
R587	C-CARBON R	RN72K1J-104JE	435031044R1
R588	C-CARBON R	RN72K1J-103JE	435031034R1
R589	C-CARBON R	RN72K1J-103JE	435031034R1
R590	C-CARBON R	RN72K1J-472JE	435034724R1
R591	C-CARBON R	RN72K1J-472JE	435034724R1
R592	C-CARBON R	RN72K1J-103JE	435031034R1
R593	C-CARBON R	RN72K1J-103JE	435031034R1
R594	C-CARBON R	RN72K1J-272JE	435032724R1
R595	METAL O R	RS1/2WBJ-22	443522204
R596	METAL O R	RS1/2WBJ-22	443522204
R601	METAL O R	RS1WBJ-47	443624704
R602	METAL O R	RS1WBJ-47	443624704
R603	CARBON R	R16J-5.6K	417345624
R604	CARBON R	R16J-5.6K	417345624
R605	CARBON R	R16J-120	417341214
R606	CARBON R	R16J-120	417341214
R607	JMP WIRE	TA050	78002
R608	METAL O R	RS2WBJ-220	441722214F
R609	METAL O R	RS2WBJ-220	441722214F
R610	METAL O R	RS2WBJ-100	441721014F
R611	METAL O R	RS2WBJ-100	441721014F
R612	METAL O R	RS1/2WBJ-100	443521014
R701	C-CARBON R	RN72K1J-153JE	435031534R1
R702	C-CARBON R	RN72K1J-223JE	435032234R1
R703	C-CARBON R	RN72K1J-103JE	435031034R1
R705	C-CARBON R	RN72K1J-121JE	435031214R1
R706	C-CARBON R	RN72K1J-222JE	435032224R1
R707	C-CARBON R	RN72K1J-563JE	435035634R1
R707A	C-CARBON R	RN72K1J-563JE	435035634R1
R708	C-CARBON R	RN72K1J-683JE	435036834R1
R711	C-CARBON R	RN72K1J-103JE	435031034R1
R712	C-CARBON R	RN72K1J-121JE	435031214R1
R713	C-CARBON R	RN72K1J-101JE	435031014R1
R717	C-CARBON R	RN72K1J-103JE	435031034R1
R718	C-CARBON R	RN72K1J-101JE	435031014R1
R719	C-CARBON R	RN72K1J-682JE	435036824R1
R720	C-CARBON R	RN72K1J-223JE	435032234R1
R721	CARBON R	R16J-680	417346814
R722	METAL O R	RS1WBJ-390	441623914F
R723	METAL O R	RS1WBJ-390	441623914F
R724	METAL O R	RS1WBJ-390	441623914F
R725	C-CARBON R	RN72K1J-331JE	435033314R1
R726	C-CARBON R	RN72K1J-101JE	435031014R1
R727	C-CARBON R	RN72K1J-271JE	435032714R1

TA5

R728	C-CARBON R	RN72K1J-104JE	435031044R1	
R729	C-CARBON R	RN72K1J-102JE	435031024R1	
R730	C-CARBON R	RN72K1J-104JE	435031044R1	
R731	C-CARBON R	RN72K1J-103JE	435031034R1	
R732	C-CARBON R	RN72K1J-101JE	435031014R1	
R733	C-CARBON R	RN72K1J-101JE	435031014R1	
R734	C-CARBON R	RN72K1J-331JE	435033314R1	
R735	C-CARBON R	RN72K1J-472JE	435034724R1	
R736	C-CARBON R	RN72K1J-104JE	435031044R1	
R751	C-CARBON R	RN72K1J-473JE	435034734R1	
R752	C-CARBON R	RN72K1J-103JE	435031034R1	
R753	C-CARBON R	RN72K1J-103JE	435031034R1	
R754	C-CARBON R	RN72K1J-331JE	435033314R1	
R755	C-CARBON R	RN72K1J-103JE	435031034R1	
RL501	RELAY	NRL-2P2A-DC24-166	25065638	
RL502	RELAY	NRL-2P2A-DC24-166	25065638	
RL701	RELAY	NRL-2P5A-DC24-142	25065586	SPEAKER
S301	LEVER SW	NLS-122-1026-L071	25040098	INPUT SELECT
P301	PIN JACK	NPJ-1PDB509	25045718	INPUT (RCA)
P302	SOCKET	NSCT-3P2649	25052753	INPUT (XLR)
P501	CRIMP AS	CRIMP AS	20799140A	WHITE SP+
P501A	CORE	HF70T18X10X10	230970	
P502	CRIMP AS	CRIMP AS	20799139A	BLACK SP-
P503	RETAINER	(BUS-1)	27141833	
P504	RETAINER	(BUS-1)	27141833	
P507	HOLDER	(CRAMP) UA-0 V0	27190608-1	
P601	SOCKET AS	NSAS-6P1080	2009990764	
P604	RETAINER	(BUS-2)	27141834A	
P605	RETAINER	(BUS-3)	27141874	
P606	RETAINER	(BUS-4)	27141875	
P608	CRIMP AS	CRIMP AS	2069925140UL	
P701	SOCKET AS	NSAS-14P0221	2002391410	
P702	PLUG	NPLG-7P135	25055151	
P703	PLUG	NPLG-2P29	25055038	
P704	PLUG	NPLG-2P29	25055038	
A902	TAPE	TAPE(CROSS-16U)	29110083	RL501,502,701,Q603A
E601	RETAINER	KANAGU	27141059	
JL701A	WIRE HOL	NSCT-3P874	25051087	

U16 TEMPERATURE PC BOARD NAAF-7798

REF NO.	PART NAME	DESCRIPTION	PART NO.	NOTE
R710	THERMISTOR	PTH9M04BD222TS2F333	4000151	
JL701B	WIRE HOL	NSCT-3P874	25051087	

PACKING PARTS LIST

DTA--9.4

REF NO.	PART NAME	DESCRIPTION	PART NO.	NOTE
A601	PAD	AS	29092063-1	
A602	PAD	(TOP)	29092097A	
A603	PAD	(BOT)	29092098	
A605	POLY BAG	POLY BAG(720*1020)	29100035-1	
A608	TAPE	(SEROHAN)NITTO NO.29	29110149	:0.8:MT::

A610	PP TAPE	W48 OPP TAPE	29110148	1.6::MT::
A630	POLY BAG	350*250	29100097-1A	
A650	CARTON	(UDD)	29053995A	
A652	UPC LABEL	.	29363388	
A670	WRNTY CARD	(INTEGRA)	29365089	
A801	CORD AS	3.5 ST PLUG	2010415	
A802	INS MANUAL	E(DTA-9.4)	29343446A	