

**AV RECEIVER****Service Manual****DTM-7**

- ✓ Pre Issue (2017-Apr)
- ✓ Final Issue (2017-Apr)

**CONTENTS**

- ✓ [Title Page \(This page\)](#)
- ✓ [Note for Parts List](#)
- ✓ [Panel](#)
- ✓ [Reset](#)
- ✓ [Amp Diag Mode after Abnormal Conditions](#)
- ✓ [WiFi 5GHz Setting](#)
- ✓ [Model and Destination](#)
- ✓ [Firmware](#)
- ✓ [Check Idling Current](#)
- ✓ [Hookup and Setting](#)
- Trouble Shoot
- Disassembly
- ✓ [Schematic Diagram](#)
- ✓ [Exploded View](#)
- ✓ [Appendix](#)

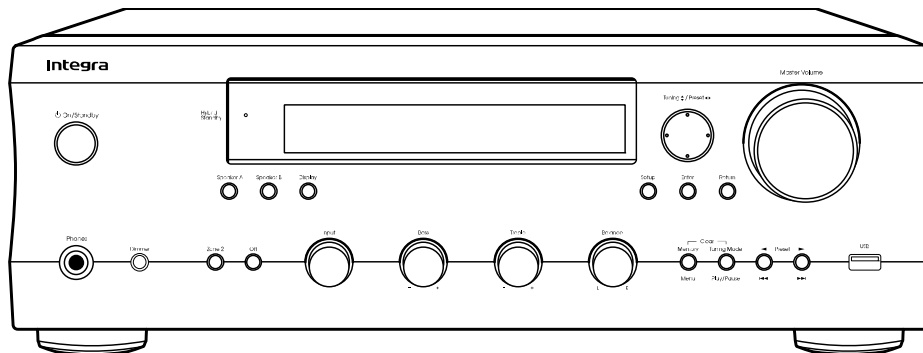

**SAFETY-RELATED COMPONENT WARNING!** : COMPONENTS IDENTIFIED BY MARK  $\Delta$  ON THE SCHEMATIC DIAGRAM AND IN THE PARTS LIST ARE CRITICAL FOR RISK OF FIRE AND ELECTRIC SHOCK. REPLACE THESE COMPONENTS WITH ONKYO PARTS WHOSE PART NUMBERS APPEAR AS SHOWN IN THIS MANUAL. MAKE LEAKAGE-CURRENT OR RESISTANCE MEASUREMENTS TO DETERMINE THAT EXPOSED PARTS ARE ACCEPTABLY INSULATED FROM THE SUPPLY CIRCUIT BEFORE RETURNING THE APPLIANCE TO THE CUSTOMER.



This service manual is intended for qualified service technicians; it is not meant for the casual do-it-yourselfer. Qualified technicians have the necessary test equipment and tools, and have been trained to properly and safely repair complex products such as those covered by this manual.

Improperly performed repairs can adversely affect the safety and reliability of the product and may void the warranty. If you are not qualified to perform the repair of this product properly and safely, you should not risk trying to do so and refer the repair to a qualified service technician.

# Integra®

Published by Onkyo & Pioneer Corporation Global CS Department

# File Name of Parts List File (EXCEL File)

## Note for Parts List

When parts list is EXCEL file, please refer to the following explanation about file name.

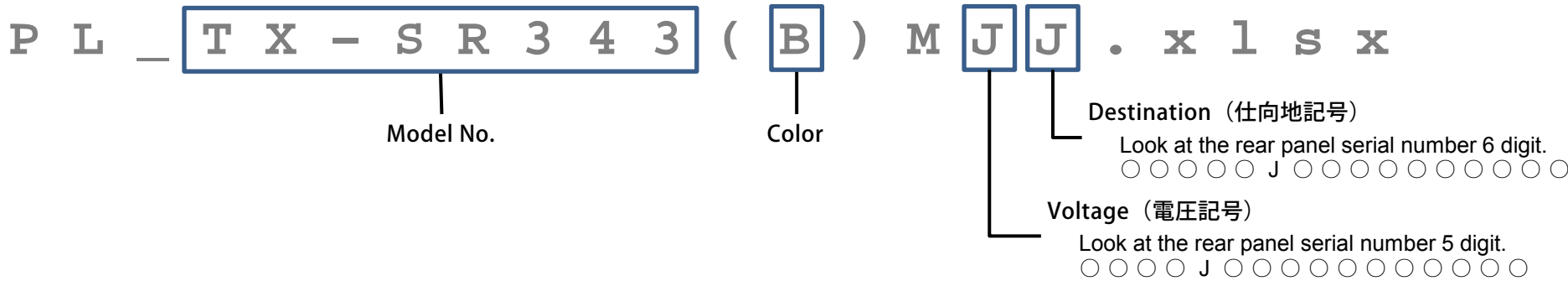

Color (色記号)			
(X)	Not related to color		
(B)	Black	(M)	Wood
(BR)	Brown	(O)	Orange
(C)	Cherry	(P)	Pink
(G)	Gold	(R)	Red
(GR)	Green	(S)	Silver
(H)	Gray	(V)	Violet
(K)	Black	(W)	White
(L)	Blue	(Y)	Yellow
(LB)	Light Blue		

Voltage (電圧記号)	
D	120V AC
G	220~230V
H	220~230/240V
J	100V AC
M	220~240V AC
P	230V AC
U	100~240V AC
V	110~240V
W	120V/220~240V
Z	※1
Speaker System (without AMP.) :	
0	Passive Subwoofer
F	Front Speaker
C	Center Speaker
R	Rear Speaker
B	Back Speaker

Destination (仕向地記号)			
A	Australia		
B	United Kingdom	Speaker System (without AMP.) :	
C	North American	L	Left channel
D	USA	R	Right channel
F	Taiwan	0	Center channel
J	Japan		
K	Korea		
L	Russia		
P	Europe		
Q	Hong Kong		
R	China		
S	Brazil		
T	Thai		
U	Worldwide		

※1 There is a charge function and a power supply (adapter) is needed, but an adapter isn't bundled.  
 (充電機能があり、電源 (アダプタ) を要するが、アダプタを付属しないもの)

Front Panel

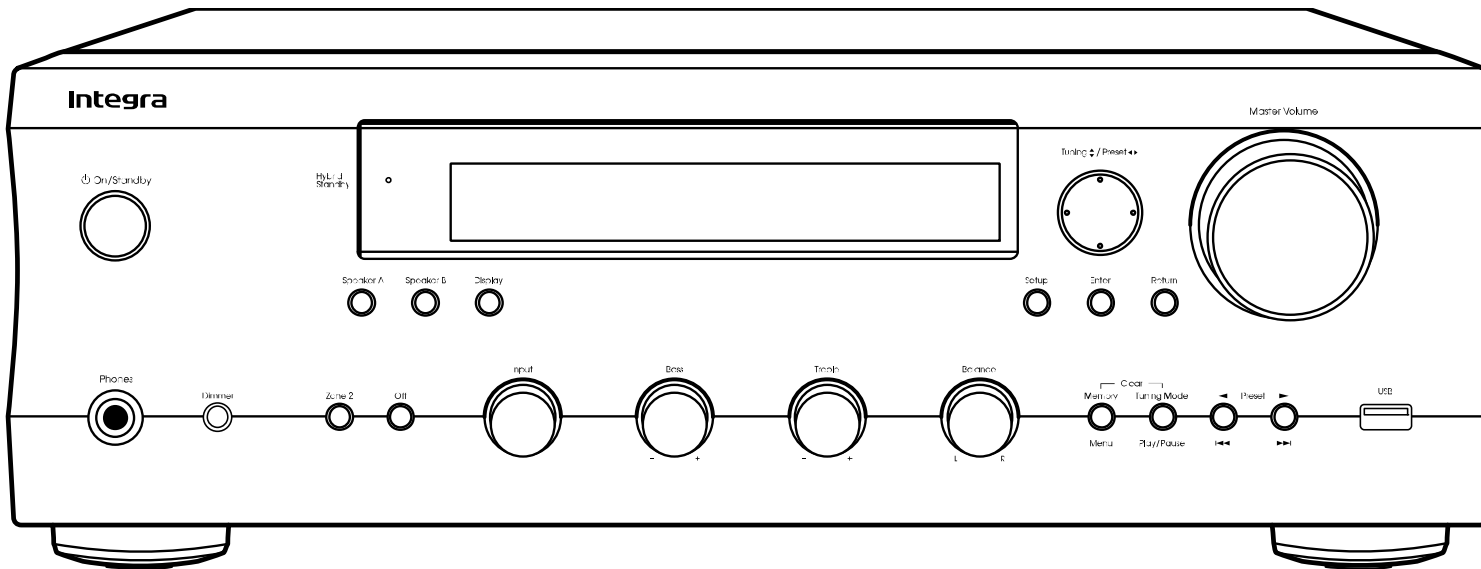

Remote Control Unit

RC-906S

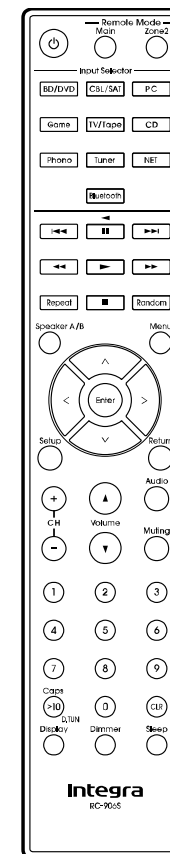

Rear Panel

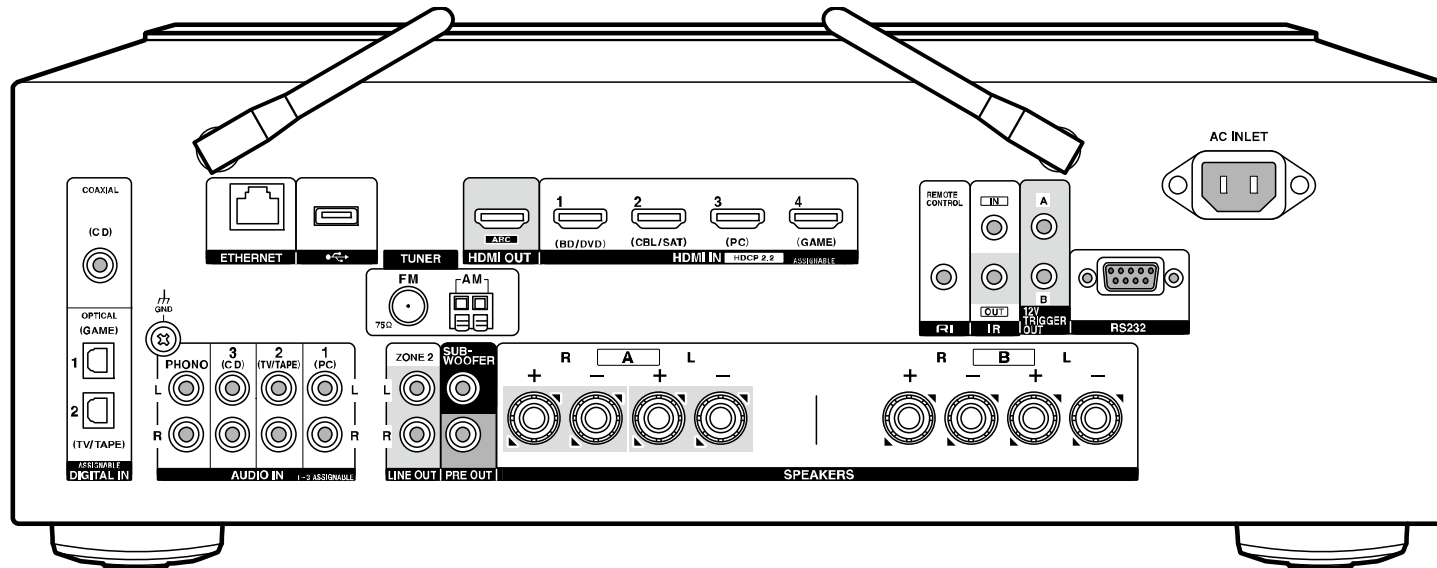

Accessory

1. Remote controller (RC-906S) (1)
2. Batteries (AAA/R03) (2)
3. Power cord (1)
4. FM indoor antenna (1)
5. AM indoor antenna (1)

Dimensions (W x H x D) : 17-1/8" x 5-7/8" x 12-15/16" (435 mm x 149.5 mm x 328.5 mm)

Weight : 18.7 lbs/8.5 kg

**【STORE】**

[ SETUP ] + [ ENTER ] x 2

**【RESET】**

1. Volume 40
2. [ MEMORY ] + [ ON/STANDBY ] → [ RETURN ] x 2
3. Unplug the power cord from AVR after the disappeared "All Clear" of FL tube and AVR goes standby.

**【RECALL】**

[ SETUP ] + [ RETURN ] x 2

The unit goes into standby automatically when detect the abnormal condition of thermal detection, dc voltage detection or current detection. (e.g. TX-NR555 block diagram below)

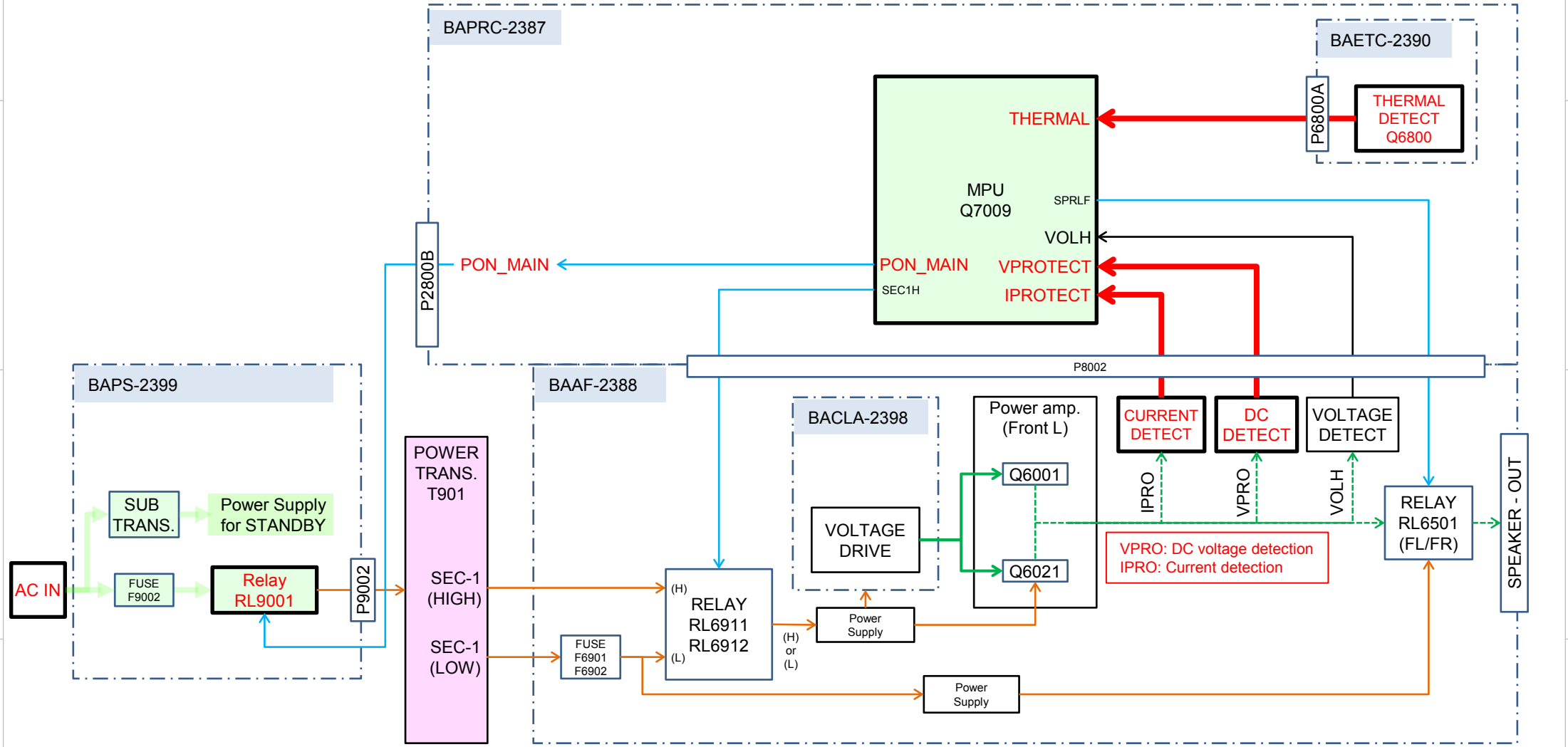

# Self-diagnostics

This function is for avoiding the rupture of electrolytic capacitors with amplifier circuit failure during power-ON.

## Operation of Self-diagnostic

Self-diagnostic will start at the timing of next power on, after goes to the protect mode by Current detection or DC voltage detection.

Only On/Standby key could work in this mode. Also remote control does not work. However, the CLEAR operation is enabled.

During Self-diagnostic, the power supply for amplifier circuit become low voltage state(SEC1-LOW), and the speaker relay will be turned off. Then, MPU will check each amplifier circuits Internally by entering the test signal (20 kHz,-20 dBFS sine wave) to each channel from DSP.

MPU will judge the amplifier circuit is good or not from VOLH value.

The normal range of VOLH value is  $0.04\text{ V} < \text{VOLH} < 0.20\text{ V}$ .

If VOLH value is in the out of this range, it will be judged as NG (No good).

## No problem found

When protected by current detection, and no problem found, "CHECK SP WIRE" will be displayed. In this State, Only the On/Standby key is effective. And if do not anything for 3 minutes, unit goes into standby automatically.

When protected by a DC voltage detection, and no problem found, unit goes into normal operation.

## Problem found

When judged as there is a problem on any channel, the information of channel that has a problem will be displayed as in the right figure.

In this State, Only the On/Standby key is effective. Also remote control does not work. If do not anything for 3 minutes, unit goes into standby automatically. This state will keep also after unit turn on/off, or AC unplugged.

the power supply for amplifier circuit become low voltage state(SEC1-LOW), and the speaker relay will be turned off.

# Amp Diag Mode after Abnormal Conditions

Display of during Self-diagnostics

2 Line FL tube type

A M P      D i a g      M o d e

1 Line FL tube type

A M P      D i a g      M o d e

"Mode" This part display the channel which is currently checked. (E.g. "[FL]", etc.)

Display of when problem found

2 Line FL tube type

N G      C H :      L C R S L S R B L B R

1 Line FL tube type

N G : L C R S L S R B L B R

- L → Front L channel      S L → Surround L channel
- C → Center channel      S R → Surround R channel
- R → Front R channel      B L → Surround back L channel
- B R → Surround back R channel

# Repair Process and How to Confirm

## Confirmation of the protect cause

While NG channel is displayed, You can confirm the protect cause by following the step below.

1. Press the Enter button
2. The protect cause are displayed for 5 seconds.

Please check the around of those amplifier circuit and repair it.

## Clear of NG CH information

After repair, you can clear NG CH information by following the steps below.

1. Press the On/Standby key while pressing the Enter key.
2. Display as in the right figure appears.
3. Unit goes into Standby automatically after 5 seconds.

Self-diagnostic will start again at the timing of next power on.

By this, You can verify whether repair was properly or not.

If problem found after repair, please re-check the around of its circuit.

## Cancel of Self-diagnostic

You can cancel this mode by clear operation (press Standby key while pressing CBL/SAT key).

After cancel this mode, receiver will be started as normal operation.

## Manual Execution of Self-diagnostic

1. [DIMMER] + [ON/STANDBY] x 2

Main Firmware Version will appear on the main unit's display.

2. [SETUP] or [HOME]

[Service information](#) will appear on the main unit's display

3. [ENTER]

Display as in the right figure appears.

4. [STANDBY/ON]

Unit will go into standby.

5. [STANDBY/ON]

Unit will turn on. Then self-diagnostic will start automatically.

# Amp Diag Mode after Abnormal Conditions

## Protected by current detection

D E T . P R O T E C T : I

## Protected by DC Voltage detection

D E T . P R O T E C T : V

## Clear of NG CH information

N G C H C L E A R

## Manual Execution of Self-diagnostic

A M P D I A G T E S T O N

**IMPORTANT!!**

**Back Ground:**

It is totally different from Radio Law at the each country on 5GHz band.  
It means it is totally different from enabled Channel of 5GHz band at the each country.  
We define the “[Country Code](#)” for 5GHz band.

**You must set up the appropriate country code to the product.**

**Example;**

**Case1:**

When you use the “P” destination products and bring move to Russia or Israel,  
If you did not setup change country code and use in Russia and Israel,  
You will be on the illegal Radio Law in Russia and Israel.

**Case2;**

When you use “C” or “D” destination product bring move to Japan or Taiwan,  
If you did not setup change country code and use in Japan and Taiwan,  
You will be on the illegal Radio Law in Japan and Taiwan.

**Service Parts information:**

The default country code is set on “Processing Circuit Board(PRC board)”.  
You must make sure and set up the “[Country Code](#)” when you replace the processing circuit pc board.  
Otherwise You and your customer should be on the illegal Radio Law and

**IT HAS POSSIBILITY TO HAVE A RISK OF PUNISHMENT FROM EACH COUNTRY GOVERNMENT.**

If you did not make sure country code and no setup code and face any trouble,  
We does not have any responsibility.

For setting up the [Country Code](#),

**Please ask the procedure of changing country code to your distributor or our sales.**

It is no described the procedure of changing [Country Code](#) on this Service Manual

If you have any trouble of unclear procedure for update country code,  
Please contact our sales department.

**PRC Board Default Value of Country Code**

The PRC board is already set default Country Code by the representative destination.  
To confirm the default country code, Please refer to the "[How to read PRC Board part number and Default value of Country Code](#)" section.



**IMPOTANT!!**

**Make sure and Setup Country Code**

You have to make sure country code for using or replacing "Processing Circuit PC Board".

It means that you have to make sure [country code](#) between using Processing Circuit PC board( PRC Board) and your customer's country code.

When it is not match PRC board default country code and customer's country, you have to setup [Country Code](#).

**Case3;**

When you repair the "P" destination products and replace "P" destination PRC Board and the customer live in UK, It is no necessary to setup Country Code

Because "P" destination PRC board already setup "EU" country code.



Match Country code  
**NO NECESSARY TO SETUP COUNTRY CODE**

**Case4;**

When you repair the "P" destination products and replace "P" destination PRC board and the customer live in Russia, It is necessary to setup Country Code

Because "P" destination PRC Board already setup "EU" country code.

However, the customer's country code is "RU". It means no match PRC Board code and Customer's code.



No Match Country code  
**NECESSARY TO SETUP COUNTRY CODE**

**Case5;**

When you repair the "C" destination products and replace "C" destination PRC board and the customer live in US, it is no necessary to setup Country Code

Because "C" destination PRC board already setup "US" country code.



Match Country code  
**NO NECESSARY TO SETUP COUNTRY CODE**

**Case6;**

When you repair the "C" destination product and replace "C" destination PRC board and the customer live in Taiwan, It is necessary to setup Country Code.

Because "C" destination PRC Board already setup "US" country code as default.

However, the customer's country code is "TW". It means no match PRC Board code and the customer's country code



No Match Country code  
**NECESSARY TO SETUP COUNTRY CODE**

Region	Country	Code
America	USA	US
	Canada	US
	Mexico	US
	Brazil	US
	Chile	CL
	Guatemala	US
	Puerto Rico	US
	Trinidad	TT
	Dominican Rep	US
	Argentina	AR
	Ecuador	US
	Paraguay	PY
	Colombia	US
	Guam	US
	Panama	US
	Costa Rica	US
	Uruguay	UY
Peru	PE	

Region	Country	Code
Asia / Oceania	Japan	JP
	China	CN
	Hong Kong	EU
	Korea	KR
	Taiwan	TW
	Singapore	SG
	Malaysia	MY
	Philippines	EU
	Vietnam	EU
	Indonesia	ID
	Sri Lanka	EU
	Australia	AU
	New Zealand	AU
	Thailand	EU
	India	IN
	Pakistan	PK

Region	Country	Code
Middle East	UAE	EU
	Bahrain	BH
	Kuwait	KW
	Oman	EU
	Qatar	QA
	Lebanon	EU
	Jordan	JO
	Saudi Arabia	EU

Region	Country	Code
Europe / Africa	Germany	EU
	UK	EU
	France	EU
	Netherlands	EU
	Italy	EU
	Switzerland	EU
	Denmark	EU
	Sweden	EU
	Austria	EU
	Belgium	EU
	Spain	EU
	Norway	EU
	Finland	EU
	Czech	EU
	Israel	IL
	Ukraine	EU
	Hungary	EU
	Slovakia	EU
	Luxembourg	EU
	Turkey	EU
	Portugal	EU
Malta	EU	
Latvia	EU	
Poland	EU	

Region	Country	Code
Europe / Africa	Cyprus	EU
	Estonia	EU
	Slovenia	EU
	Bulgaria	EU
	Greece	EU
	Romania	EU
	Lithuania	EU
	Serbia	EU
	Croatia	EU
	Ireland	EU
	Macedonia	EU
	Moldova	EU
	Russia	RU
	Andorra	EU
	Armenia	EU
	Azerbaijan	EU
	Belarus	EU
	Bosnia and Herzegovina	EU
	Northern Cyprus(Turkey)	EU
	Georgia	EU
	Iceland	EU
	Kazakhstan	EU

Region	Country	Code
Europe / Africa	Liechtenstein	EU
	Monaco	EU
	Montenegro	EU
	San Marino	EU
	Vatican City	EU
	Kosovo	EU
	Kaliningrad(Russia)	RU
	Gibraltar(UK)	EU
	Canary Islands(Spain)	EU
	Ceuta	EU
	Melilla	EU
	Morocco	MA
	Algeria	EU
	Tunisia	TN
	Egypt	EG
	Mauritius	US
South Africa	EU	

# How to read PRC Board part number and Default value of Country Code

1B5142387-1J270MDC

Board No.

Suffix No.

**Model Number Last 3 Digit**

270 : TX-8270  
TM7 : DTM-7

**Destination**

**PRC Board Default setting Country Code**

Dst	Code	Main Country
C	US	North America
D	US	United State
S	US	Brazil
P	EU	Europe
B	EU	United Kingdom
Q	EU	Hong Kong
T	EU	Thai
L	RU	Russia
A	AU	Australia / New Zealand
R	CN	China
F	TW	Taiwan
K	KR	Korea
J	JP	Japan

# How to check Firmware Version & Preparation of Update

### Step1 : [DIMMER] + [ON/STANDBY] x 2

Main Firmware Version will appear on the main unit's display.

### Step2 : [BASS +1]

DSP Firmware Version will appear on the main unit's display.

### Step3 : [BASS +2]

Main Firmware Version will appear on the main unit's display again.

### Step4 : [TONE +3 over]

Main/DSP Firmware Version will appear momentally on the main unit's display.

### [Preparation of Update]

1. Connect the USB storage device to your PC. If there is any data in the USB storage device, remove it.
2. Download the firmware file (package file) from the Onkyo FTP-server. However European service partners should download the firmware file (package file) from the ExtraNet.

Onkyo FTP-server: <ftp://manex.onkyo.co.jp/>

ID and Password are those we informed when changed.

Filename is as follows: ONKRCV0003\*\*\*\*\*.zip

Unzip the downloaded file. A following file is created.

ONKRCV0003\*\*\*\*\*.of0

ONKRCV0003\*\*\*\*\*.of1

ONKRCV0003\*\*\*\*\*.of2

ONKRCV0003\*\*\*\*\*.of3

3. Copy it to the USB storage device. Be careful not to copy the zip file.
4. Remove the USB storage device from your PC.

# How to Update (service mode) 1/2

Overwriting is also possible.

1. Connect the USB storage to the USB port on the unit.



2. Turn on the unit. It takes some time to start after you switch on the unit.  
Press: [DIMMER] + [ON/STANDBY] x 2
3. Press [RETURN] button, Then it is displayed as below



If you need each module of the firmware update, you can select the module by pressing PRESET < and > button.

If you need change source NET or USB, you can select the source by pressing TUNING UP and Down key

It should be updated firmware by selecting USB -> ALL normally.

- USB -> ALL: ALL firmware update
- USB -> DA830: DA830 firmware update
- USB -> MMPU: MainMCU firmware update
- USB -> WORK: Compare between Receiver and USB, Only update new version firmware

- NET -> ALL: ALL firmware update by network (default).
- NET -> DA830: DA830 firmware update by network.
- NET -> MMPU: Main MCU firmware update by network
- NET -> WORK: Compare between AVR and MMC,  
Only update new version firmware by network



The default setting is " ALL"

**CAUTION: When you will update each module firmware, you have to keep combination of firmware.**

## How to Update (service mode) 2/2

## Firmware

4. Press [ENTER] button. Start update firmware.



5. Wait until update is completed. When the update ends, "Completed!" is displayed. When "Completed!" message appeared, you can power off by pressing "ON/STANDBY" button. (If you leave it, it automatically turns standby mode. )



6. Press [ON/STANDBY] button, and the unit turns on.
7. Check the new FW version number.

<Note>

If the procedure might not be successful, please select "USB -> ALL".

# Model and Destination

- 1. [ TUNING UP ] + [ ON/STANDBY ]
- 2. [ DIMMER ]
- 3. Rotate [ BASS ] x5

Model Name	Destination	FL Display											
DTM-7	DD	D	T	M	7			D	D	1	0	0	0



# How to Check Idling current

## a. Idling Pre-check

Channel FL,FR  
Terminals P6021,P6022

- \*Connect 1/4W 100 ohms resisters in each probe of multi meter .
- \*Make sure from 1mV to 21mV, When it is not this range, you have to make sure again repair.

## b. Aging

The AVR is turned on about 6 minutes for aging.

## c. Idling After-check

- \*Connect 1/4W 100 ohms resisters in each probe of multi meter .
- \*Make sure from 1mV to 21mV, When it is not this range, you have to make sure again repair.

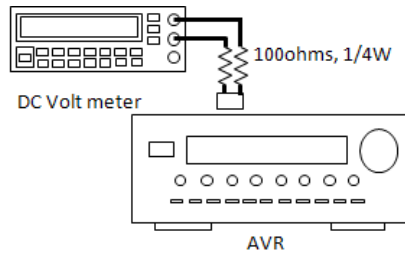

# No Sound

## Hookup and Setting

### ■ No sound from connected player

- Chose input selector which is assigned to connected input terminal ?
- Isn't muting on ?

### ■ No sound from connected TV

- Chose wrong input selector ?
- Connect to this model's HDMI OUT terminal from TV by HDMI cable ?
- When TV supports ARC function, connect to his model's HDMI OUT terminal from TV's HDMI input terminal for ARC function ?
- When TV doesn't support ARC function, connect TV to this model with optical cable etc. ?
- Isn't muting on ?

### ■ No sound from some connected loudspeaker(s)

- No sound loudspeaker(s) config is enabled ?

### ■ No sound from all connected TV or Blu-ray player etc.

- After chose loudspeaker volume level setting, test tone is OK ?

### ■ No problem about above items

- Unplug power cord  
After 10 seconds, connect power cord again
- Reset this model

# No Picture

## Hookup and Setting

### ■ In general

- Connection cable is bent , twisted or damaged ?
- Input is switched on TV ?

### ■ No picture from connected player by HDMI input terminal

- Chose input selector which is connected to player ?
- Listening mode is not Pure Audio ?
- Don't use HDMI-DVI adaptor. From personal computer ?

### ■ No picture from connected player by component video terminal

- Output to TV connected to component video out terminal from player's picture connected to the composite video input terminals ?

### ■ No problem about above items

- Unplug power cord  
After 10 seconds, connect power cord again
- Reset this model

# No Power

## Hookup and Setting

### ■ In general

Doesn't be connection cable bent, be it twisted and be it damaged?

### ■ There is time when indication on the front panel doesn't just light up.

Please check the connecting cord of a DISPLAY PCB.

### ■ No problem about above items

Unplug power cord

After 10 seconds, connect power cord again

Reset this model

COMMON

# PART-1 AUDIO BLOCK

# Schematic Diagram

(Analog Audio)

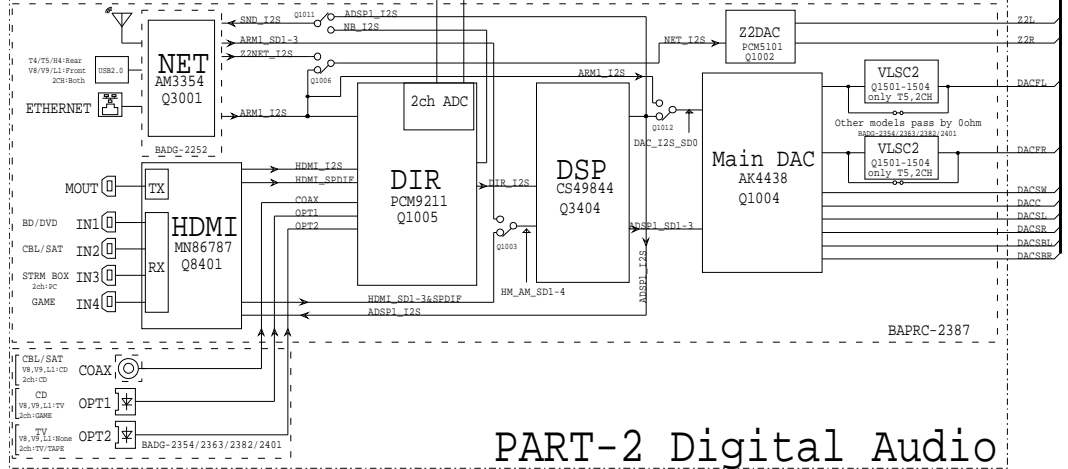
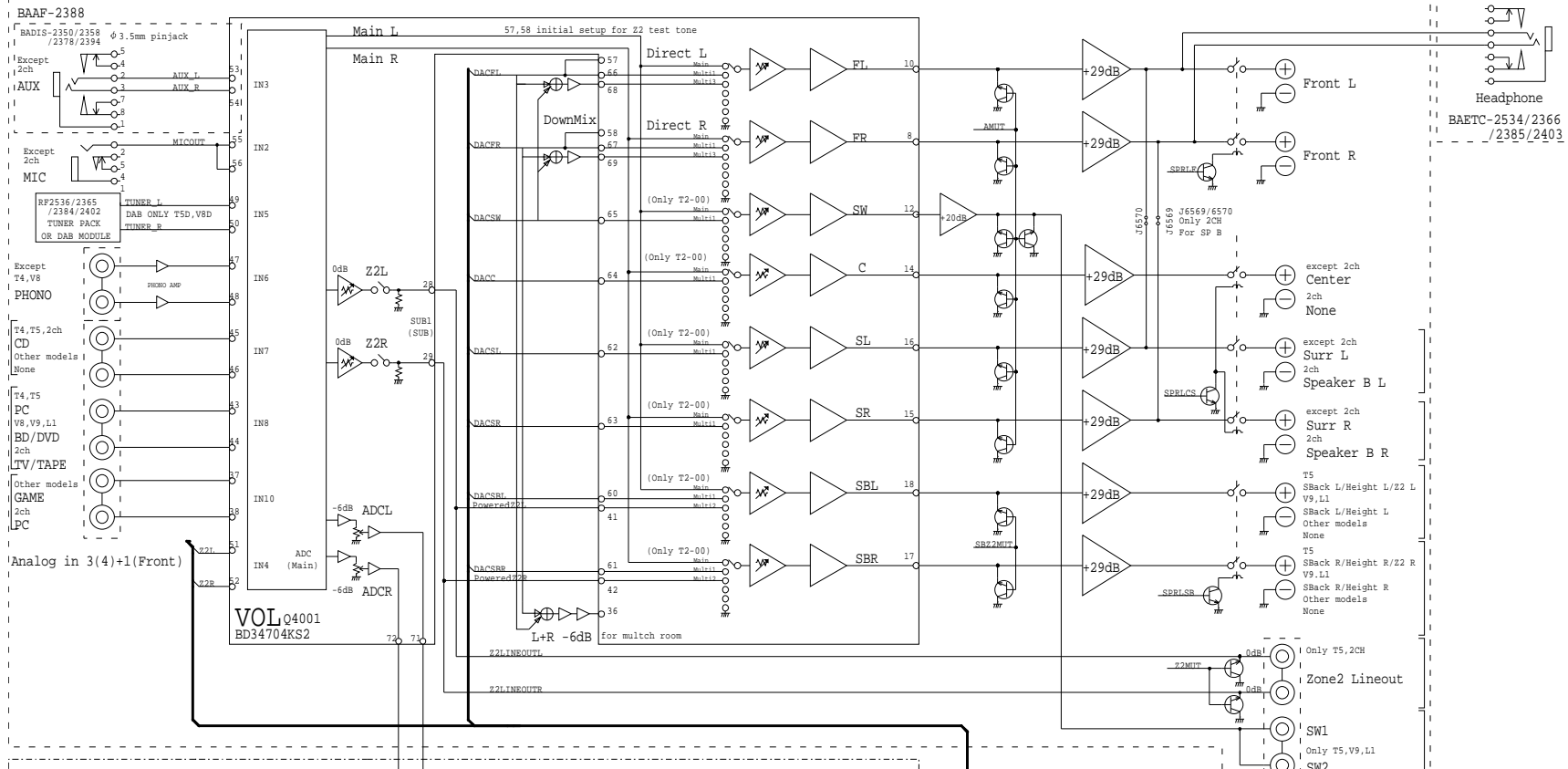

# PART-2 Digital Audio

# PART-2 DIGITAL AUDIO

# Schematic Diagram

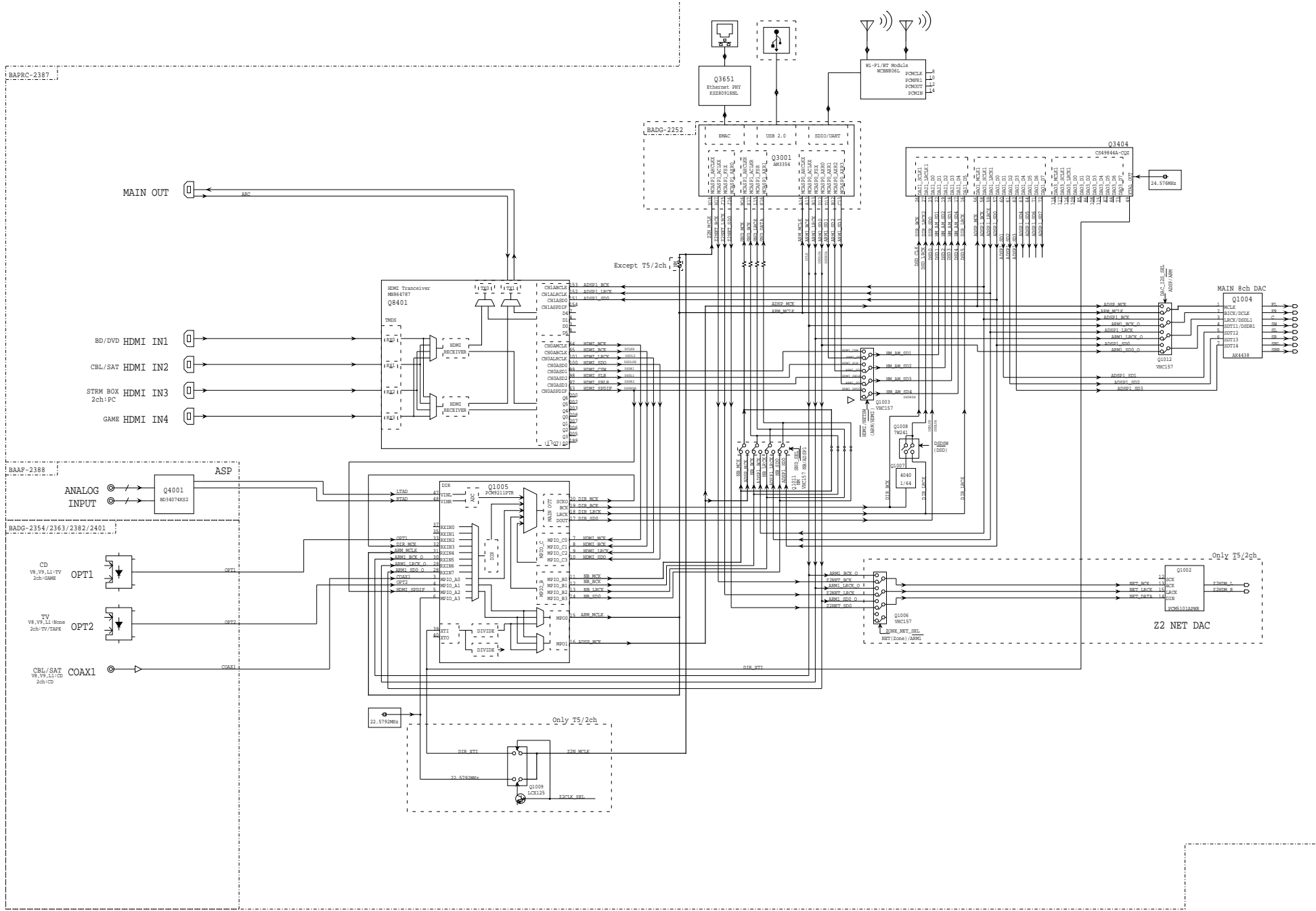

# PART-3 VIDEO BLOCK

# Schematic Diagram

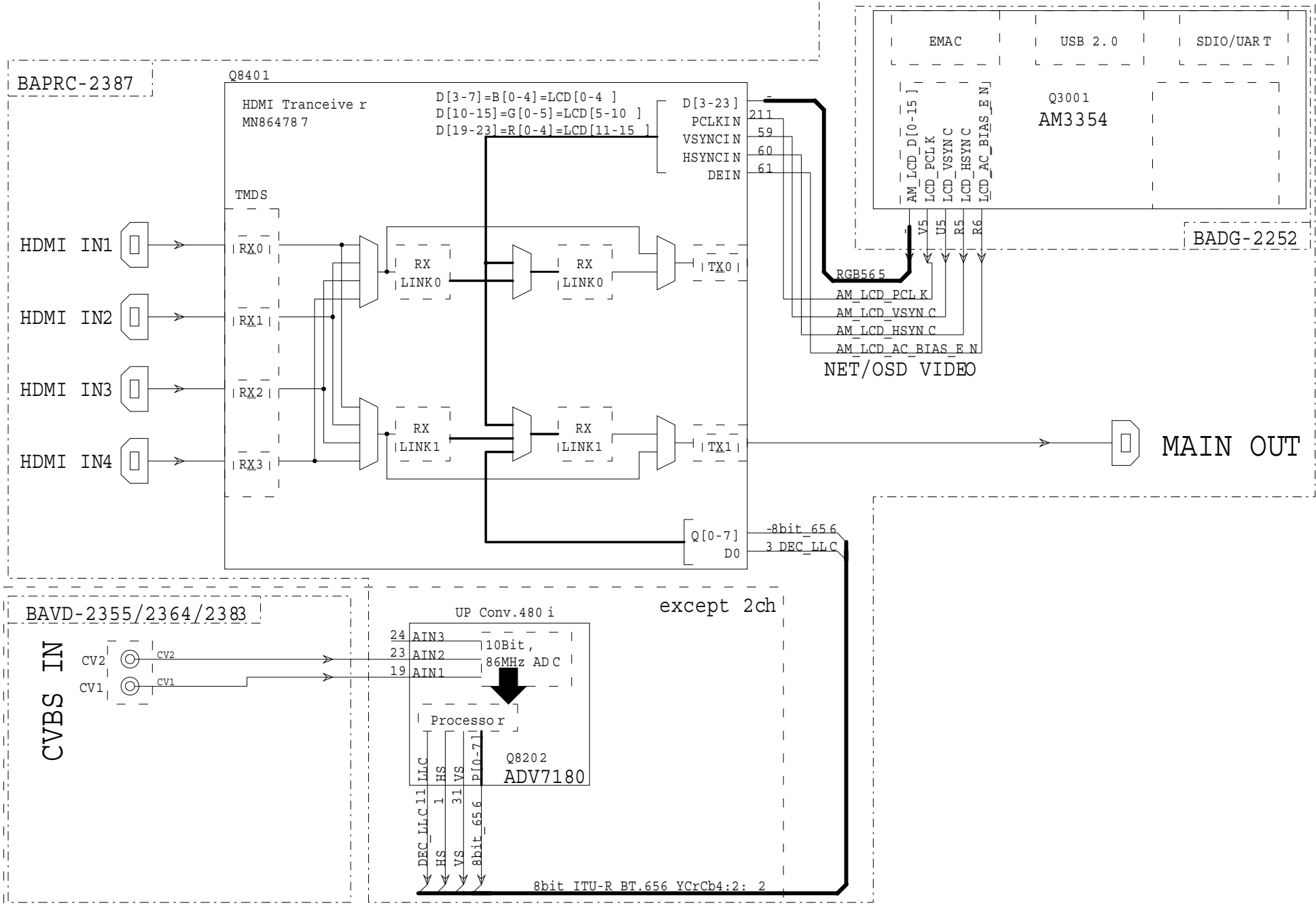

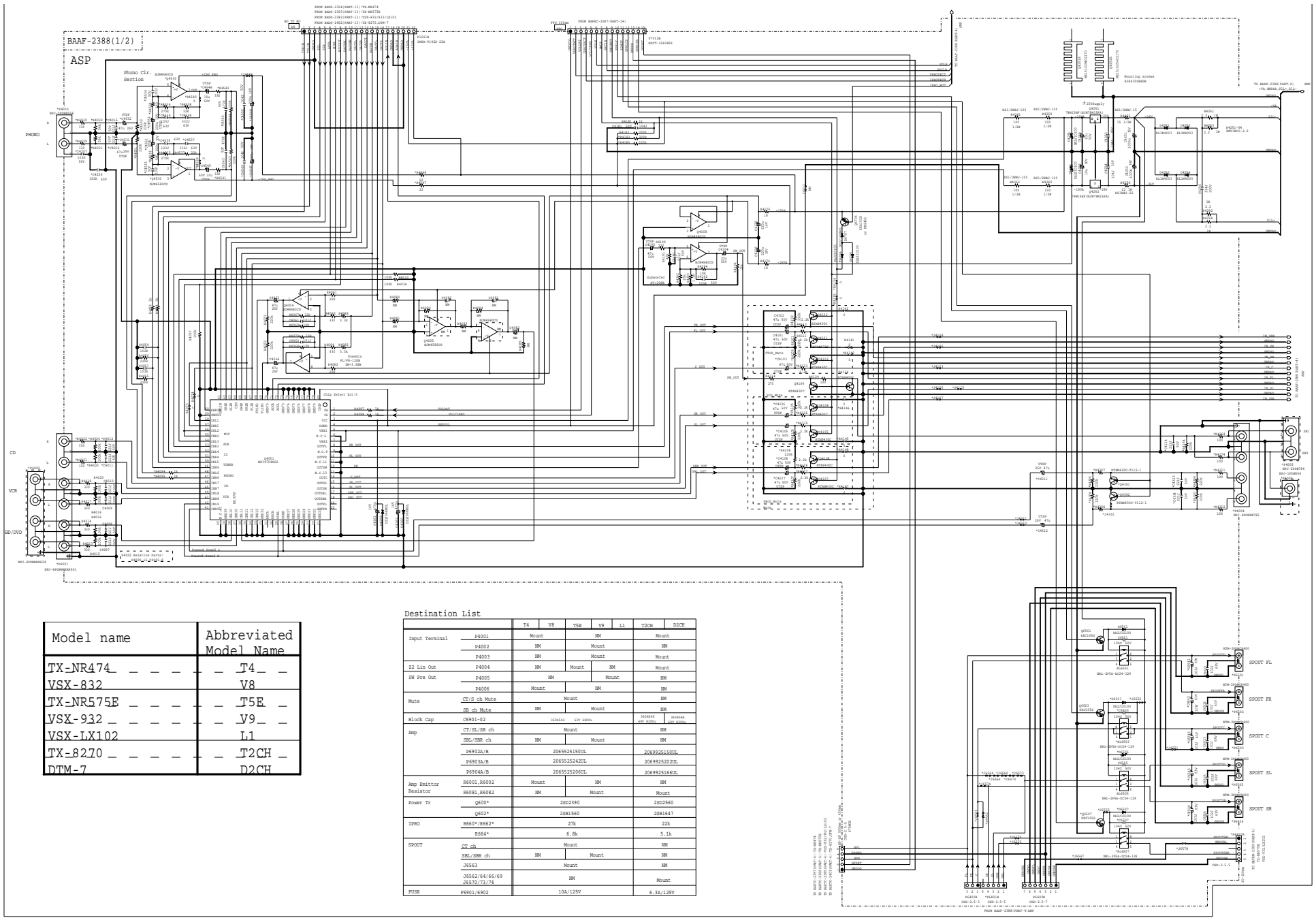

Model name	Abbreviated Model Name
TX-NR474	T4
VSX-832	V8
TX-NR575E	T5E
VSX-932	V9
VSX-LX102	L1
TX-8270	T2CH
DTM-7	D2CH

Destination List

	T4	V8	V9	L1	T2CH	D2CH
Input Terminal	P4001	Mount	Mount	Mount	Mount	Mount
	P4002	Mount	Mount	Mount	Mount	Mount
	P4003	Mount	Mount	Mount	Mount	Mount
22 Lin Out	P4004	Mount	Mount	Mount	Mount	Mount
RF Pre Out	P4005	Mount	Mount	Mount	Mount	Mount
	P4006	Mount	Mount	Mount	Mount	Mount
Mute	CT/B ch Mute	Mount	Mount	Mount	Mount	Mount
	SB ch Mute	Mount	Mount	Mount	Mount	Mount
Block Cap	C5901-02	100044	100044	100044	100044	100044
Amp	CT/SL/SR ch	Mount	Mount	Mount	Mount	Mount
	SSL/SBR ch	Mount	Mount	Mount	Mount	Mount
	P6902A/B	20655251500L	20699251500L	20699251500L	20699251500L	20699251500L
	P6903A/B	20655252420L	20699252020L	20699252020L	20699252020L	20699252020L
	P6904A/B	20655252090L	20699251600L	20699251600L	20699251600L	20699251600L
Amp Emitter Resistor	R6001, R6002	Mount	Mount	Mount	Mount	Mount
	R6081, R6082	Mount	Mount	Mount	Mount	Mount
Power Tr	Q600*	20D2390	20D2390	20D2390	20D2390	20D2390
	Q602*	20B1560	20B1560	20B1560	20B1560	20B1560
IPRO	R660*/R662*	27K	27K	27K	27K	27K
	R664*	6.8K	6.8K	6.8K	6.8K	6.8K
SPOOT	CT ch	Mount	Mount	Mount	Mount	Mount
	SSL/SBR ch	Mount	Mount	Mount	Mount	Mount
	T5E43	Mount	Mount	Mount	Mount	Mount
	T5E42/44/46/49	Mount	Mount	Mount	Mount	Mount
	T5E70/73/74	Mount	Mount	Mount	Mount	Mount
FUSE	F6901/6902	10A/125V	10A/125V	10A/125V	10A/125V	10A/125V



PART-4 AMP POWER

Schematic Diagram

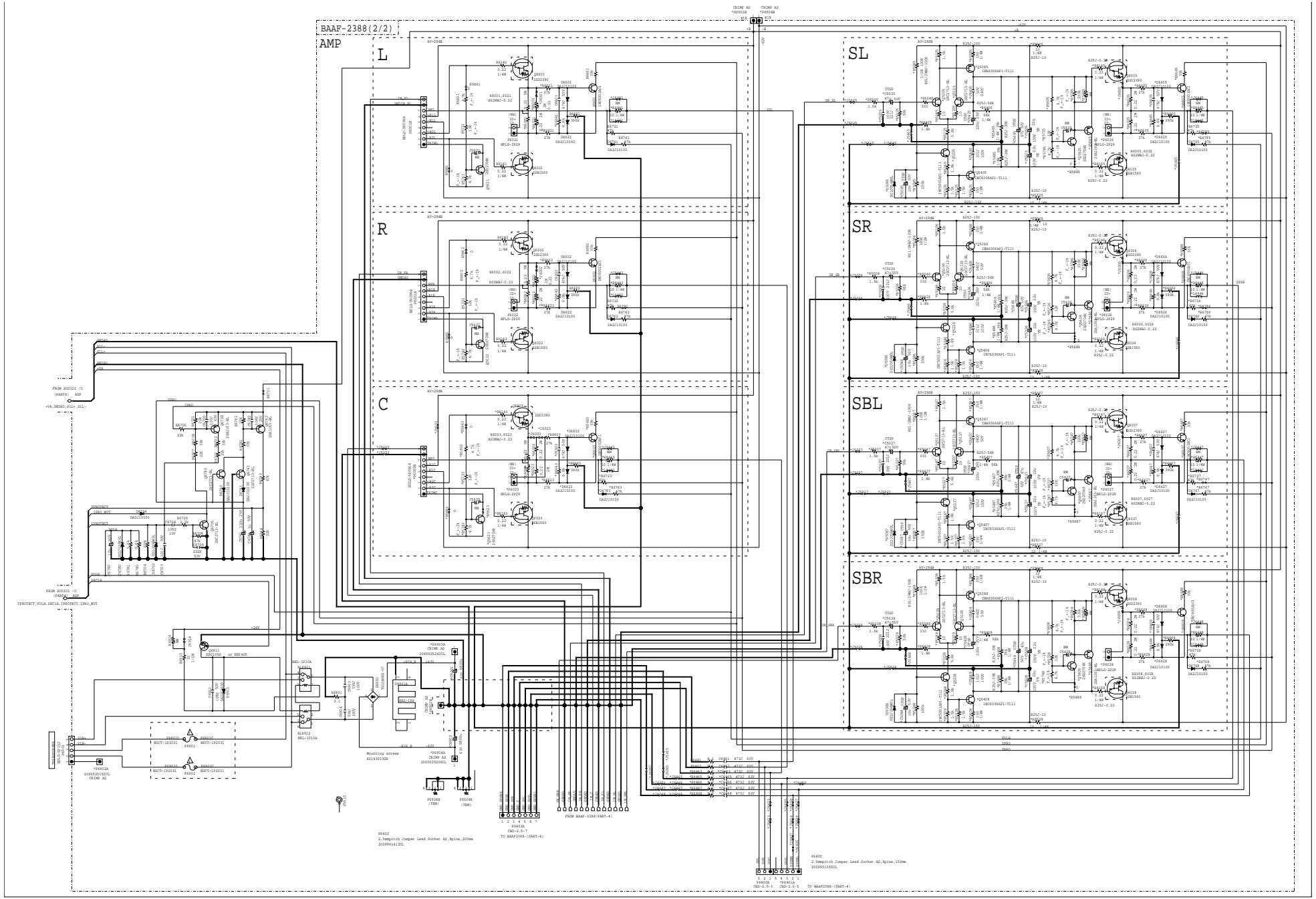

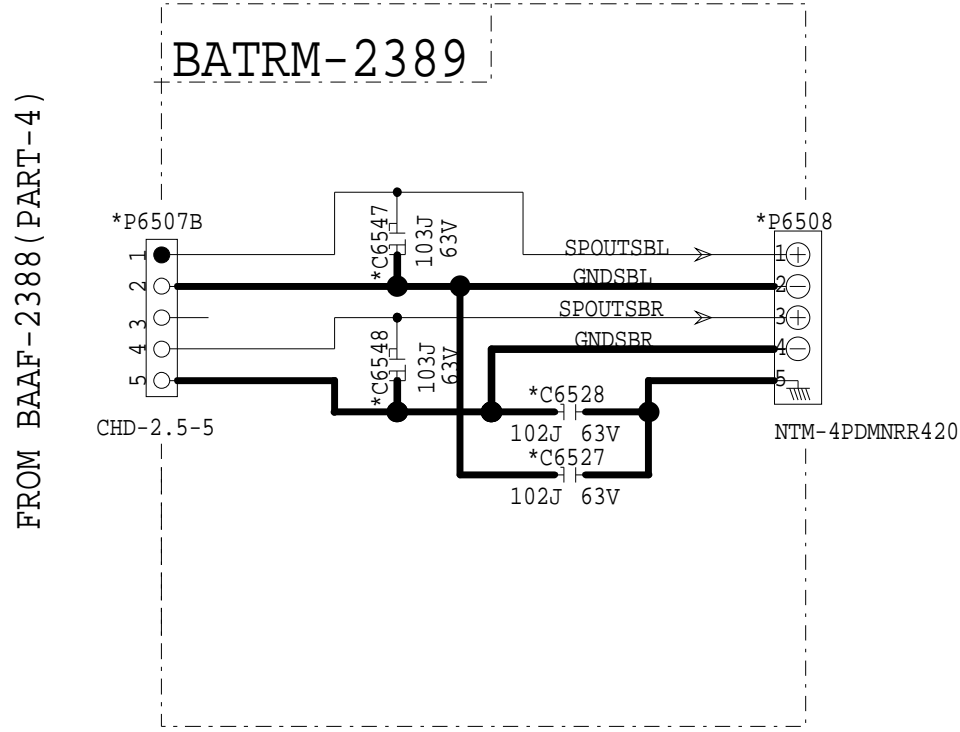

BAETC-2390

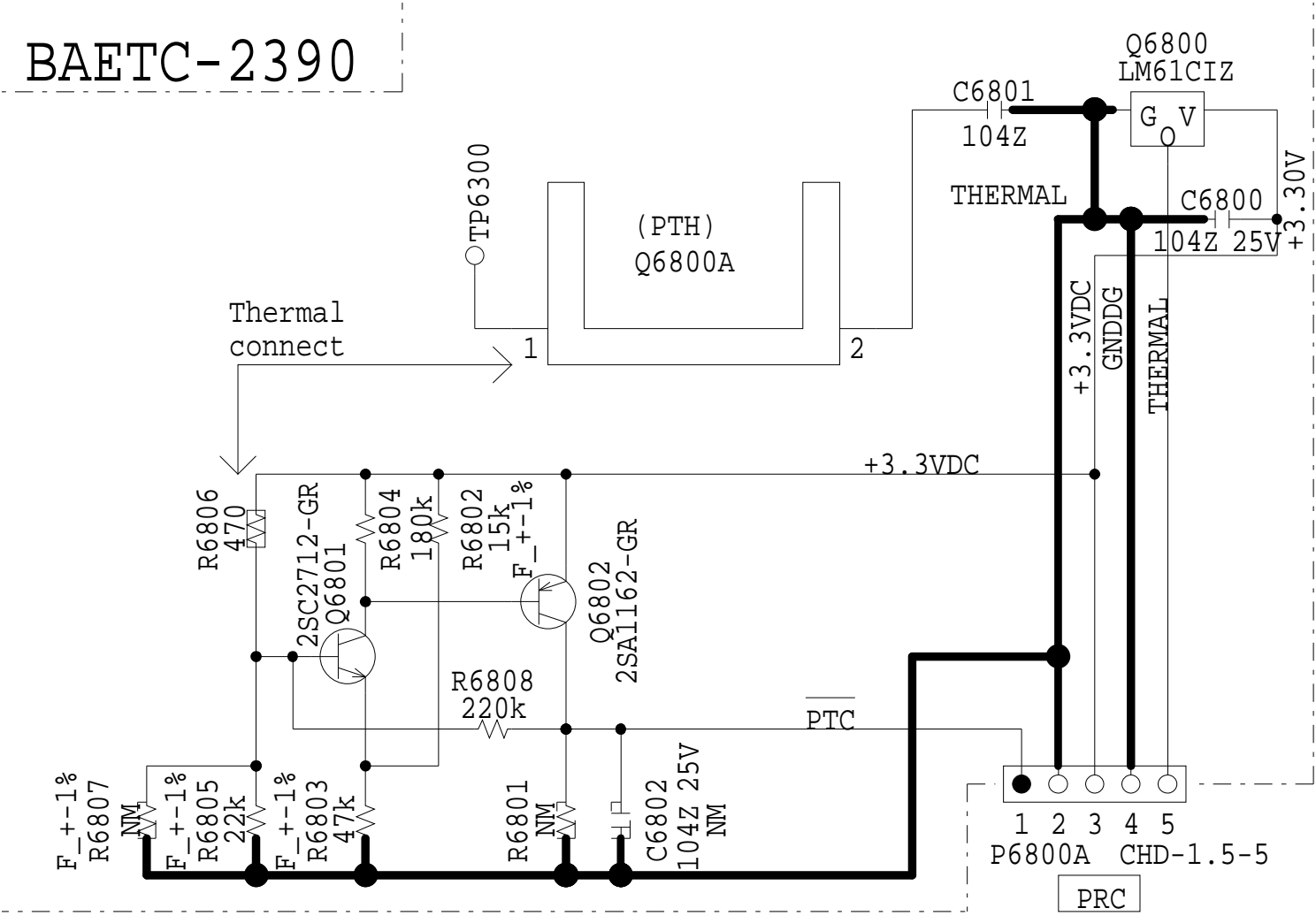

FROM BAPRC-2387(PART-14)

# PART-5 AMP CLASS-A

# Schematic Diagram

- ~~BACLA-2351~~
- ~~BACLA-2360~~
- ~~BACLA-2379~~
- BACLA-2398

## CLASS A

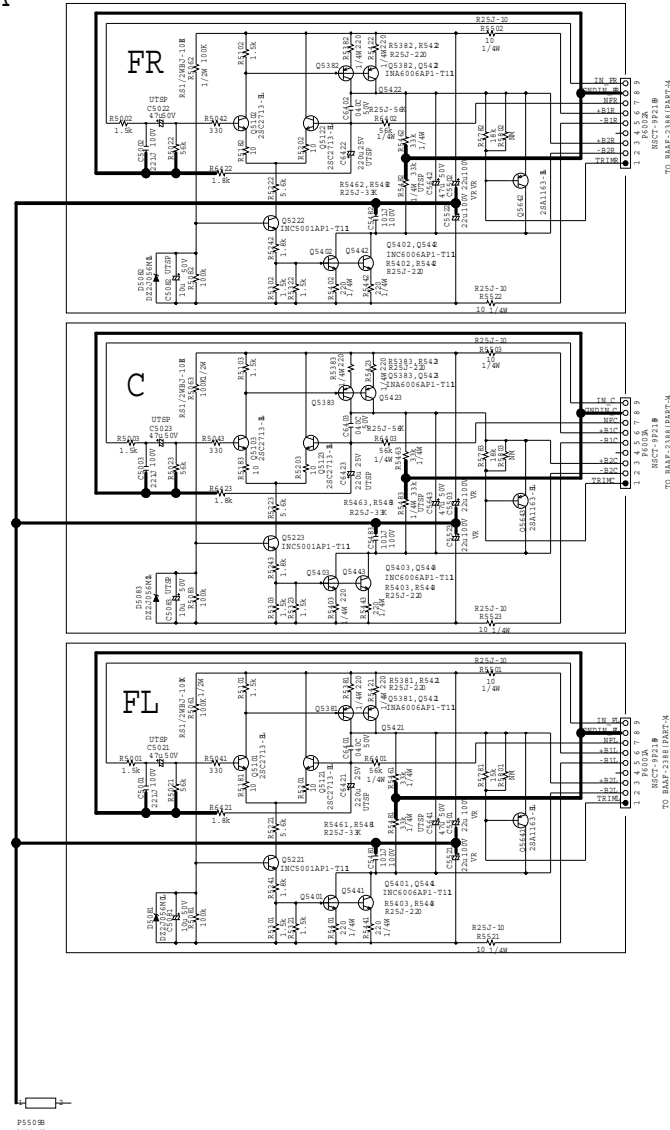

		Model				
		T4	T5	V8	V9	L1
AMP	FL	Mount				
	FR	Mount				
	C	Mount				
Q542*/Q544 *		Mount	No Mount		No Mount	
R546*/R548 *		33k	39k		33k	
R5791		15k	12k	15k	12k	22k
R5792		18k	12k	15k	12k	22k
R5793		18k	15k	12k	15k	NM
R538*/R540 *		220		150		220
R500 *		221J		471J		221J

Model name	Abbreviated Model Name	
TX-NR474	-	- T4 -
VSX-832	-	- V8 -
TX-NR575E	-	- T5E -
VSX-932	-	- V9 -
VSX-LX102	-	- L1 -
TX-8270	-	- T2CH -
DTM-7	-	- D2CH -

# PART-6 SWITCHING PS

# Schematic Diagram

THE COMPONENTS IDENTIFIED MARK  $\Delta$  ARE CRITICAL FOR SAFETY, REPLACE ONLY WITH PART NUMBER SPECIFIED.  
 VOLTAGE (MEASURED WITH VOLTMETER) IS DC VOLTAGE. (NO INPUT SIGNAL)  
 ELECTROLYTIC CAPACITORS (  $\Delta$  ) ARE IN  $\mu$ F/WV.  
 ALL CAPACITORS ARE IN pF/50WV UNLESS OTHERWISE NOTED.  
 EX) 030 -> 3pF, 330 -> 33pF, 331 -> 330pF, 333 -> 0.033 $\mu$ F  
 CIRCUIT IS SUBJECT TO CHANGE FOR IMPROVEMENT.

$\Delta$ 印は火災、感電の危険に關する部品の為、必ず指定部品を使用の事。  
 電圧表示は無信号時に測定した直流電圧を示す。  
 記入なき電解コンデンサの単位は $\mu$ F/WVである。  
 記入なきコンデンサの単位はpF/50WVである。  
 例) 030 -> 3pF, 330 -> 33pF, 331 -> 330pF, 333 -> 0.033 $\mu$ F  
 本配線図は基本配線図につき性能改善等により予告なく変更する事がある。

CAUTION  
 FOR CONTINUED PROTECTION AGAINST FIRE HAZARD,  
 REPLACE ONLY WITH FUSE OF SAME TYPE AND RATING INDICATED.

ATTENTION  
 AFIN D'ASSURER UNE PROTECTION PERMANENTE CONTRE LES RISQUES D'INCENDIE,  
 REMPLACER UNIQUEMENT PAR UN FUSIBLE DE MEME TYPE ET CALIBRATION COMME INDIQUE.

THIS SYMBOL LOCATED NEAR THE FUSE INDICATES THAT THE FUSE USED IS SLOW OPERATING TYPE  
 FOR CONTINUED PROTECTION AGAINST FIRE HAZARD, REPLACE WITH SAME TYPE FUSE.  
 RATING REFER TO THE MAKING ADJACENT TO THE SYMBOL.

CE SYMBOLE INDIQUE QUE LE FUSIBLE UTILISE EST A LENT, E POUR UNE PROTECTION PERMANENT,  
 N'UTILISER QUE DES FUSIBLES DE MEME TYPE.  
 CE DERNIER EST INDIQUE LA QU LE PRESENT SYMBOLE EST APPOSE.

MODEL	
T4	TX-NR474
T5F	TX-NR575F
V8	VSX-832
V9	VSX-932
L1	VSX-LX102
T2ch	TX-E270
D2ch	DTM-7

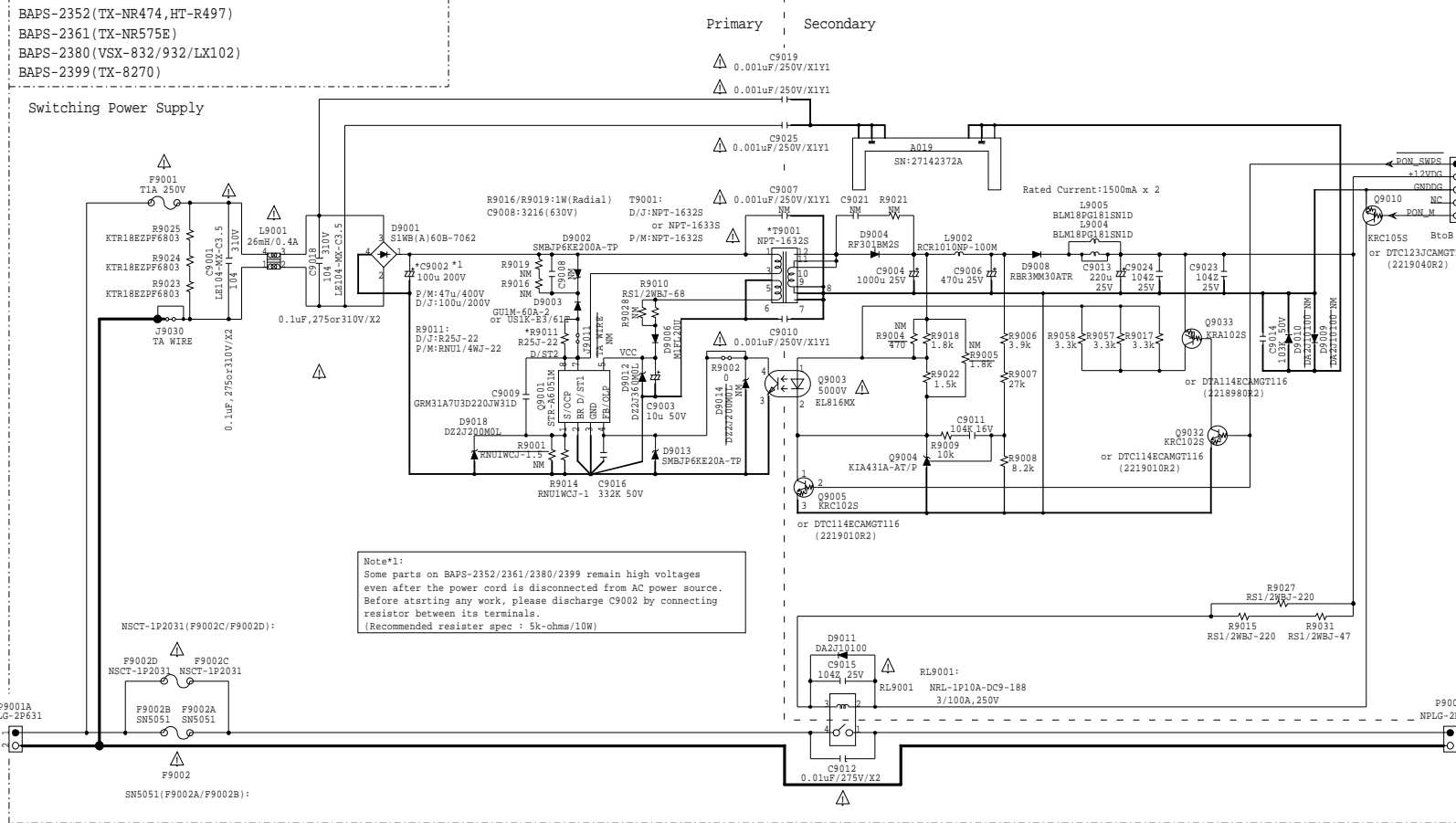

To BAPS-2353/2362/2381/2400  
 (PART-7 Sheet-10/38)

MODEL	Destination	AC POWER IN
T4	ALL	( )
T5F	ALL	( )
V8	ALL	( )
V9	ALL	( )
L1	ALL	( )
T2ch	ALL	( )
D2ch	ALL	( )

Note\*1:  
 Some parts on BAPS-2352/2361/2380/2399 remain high voltages  
 even after the power cord is disconnected from AC power source.  
 Before starting any work, please discharge C9002 by connecting  
 resistor between its terminals.  
 (Recommended resistor spec : 5k-ohms/10W)

TYPE	AC POWER
D	120Vac, 60Hz
M	220-240Vac, 50/60Hz
J	100Vac, 50/60Hz
P	230Vac, 50Hz

TYPE	F9002:Rating of Fuse				
	PS-2352	PS-2361	PS-2380	PS-2399	
D	---	---	1A	6.3A/125V 29361930	1A
M	2.5AL250V 1B	2.5AL250V 1B	2.5AL250V 1B	---	1D
J	---	---	6.3A/125V 29361930	1A	---
P	---	---	---	---	T3.15AL250V 29361747

TYPE	T901 Rating					
	T4	T5	V8	V9	L1	2ch
D	NPT-1664D	NPT-1664D	NPT-1664D	---	NPT-1664D	NPT-1687D
M	NPT-1664M	NPT-1664M	NPT-1664M	---	---	---
J	---	---	NPT-1664J	---	---	---
P	---	---	---	---	---	NPT-1687P

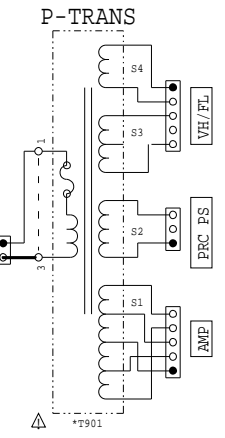

BAPS-2353/2362/2381/2400

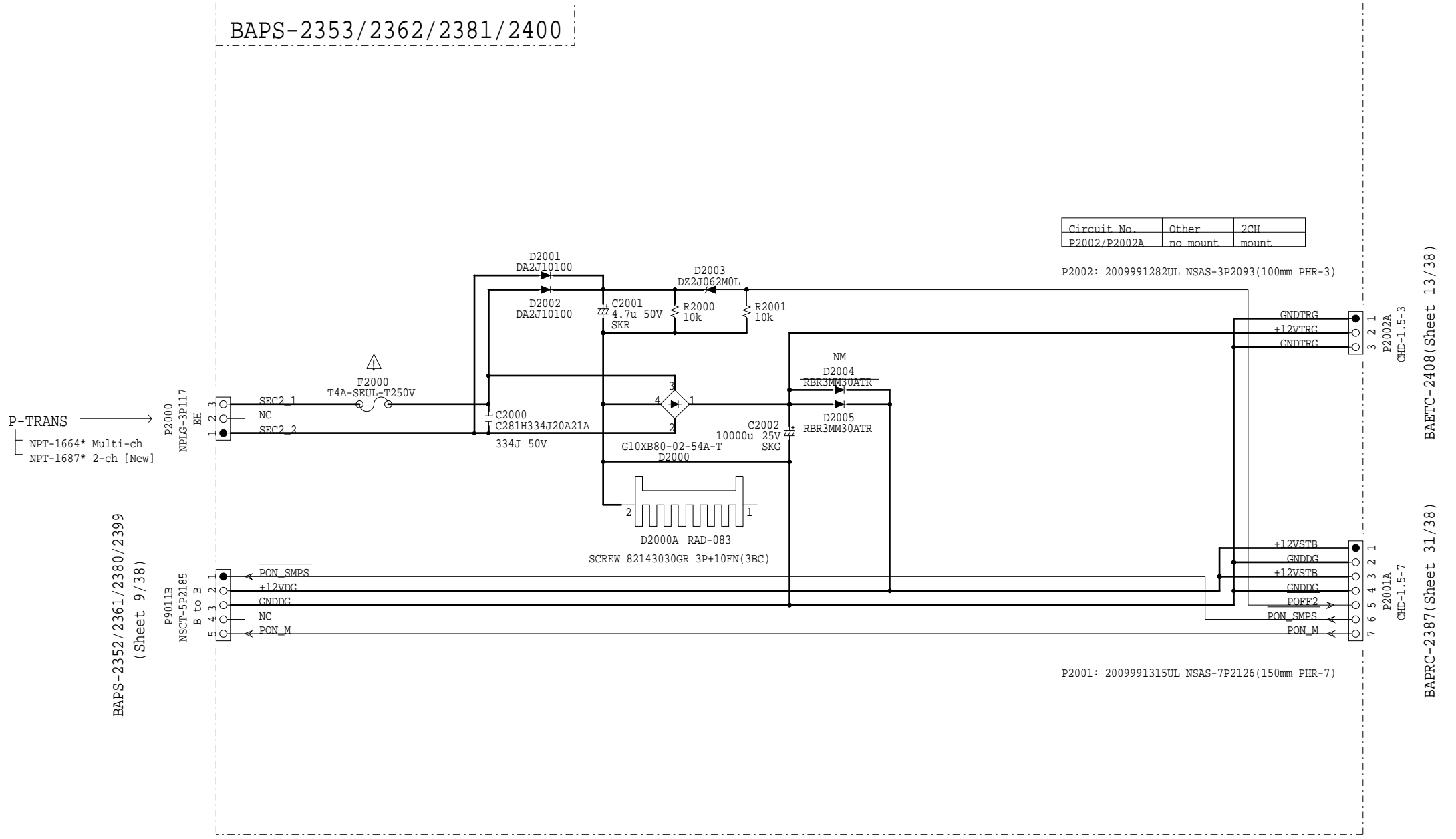

Circuit No.	Other	2CH
P2002/P2002A	no mount	mount

P2002: 2009991282UL NSAS-3P2093(100mm PHR-3)

P2001: 2009991315UL NSAS-7P2126(150mm PHR-7)

P-TRANS  
 NPT-1664\* Multi-ch  
 NPT-1687\* 2-ch [New]

BAPS-2352/2361/2380/2399  
 (Sheet 9/38)

BAETC-2408 (Sheet 13/38)

BAPRC-2387 (Sheet 31/38)

# PART-9 RS-232C, IRIN, 12VTRG

# Schematic Diagram

BAETC-2408

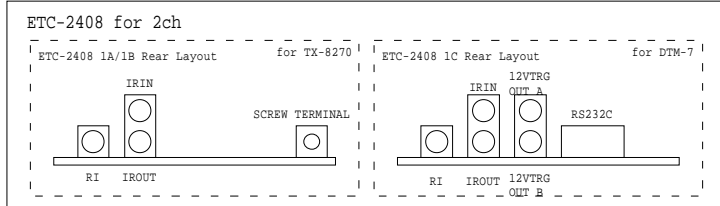

	TX-8270 -1A, -1B	DTM-7 -1C
RI	○	○
IRIN/OUT	○	○
SCREW TERMINAL (P2502)	○	×
12VTRG OUT A/B	×	○
RS232C	×	○

P2500:  
FFC:L=100mm/1.0mm pitch  
NCF5-091012 (2045091012)

Circuit No.	Destination	1A/1B	1C
*P2601, R2601, R2602, C2602		no mount	mount
P2502		mount	no mount

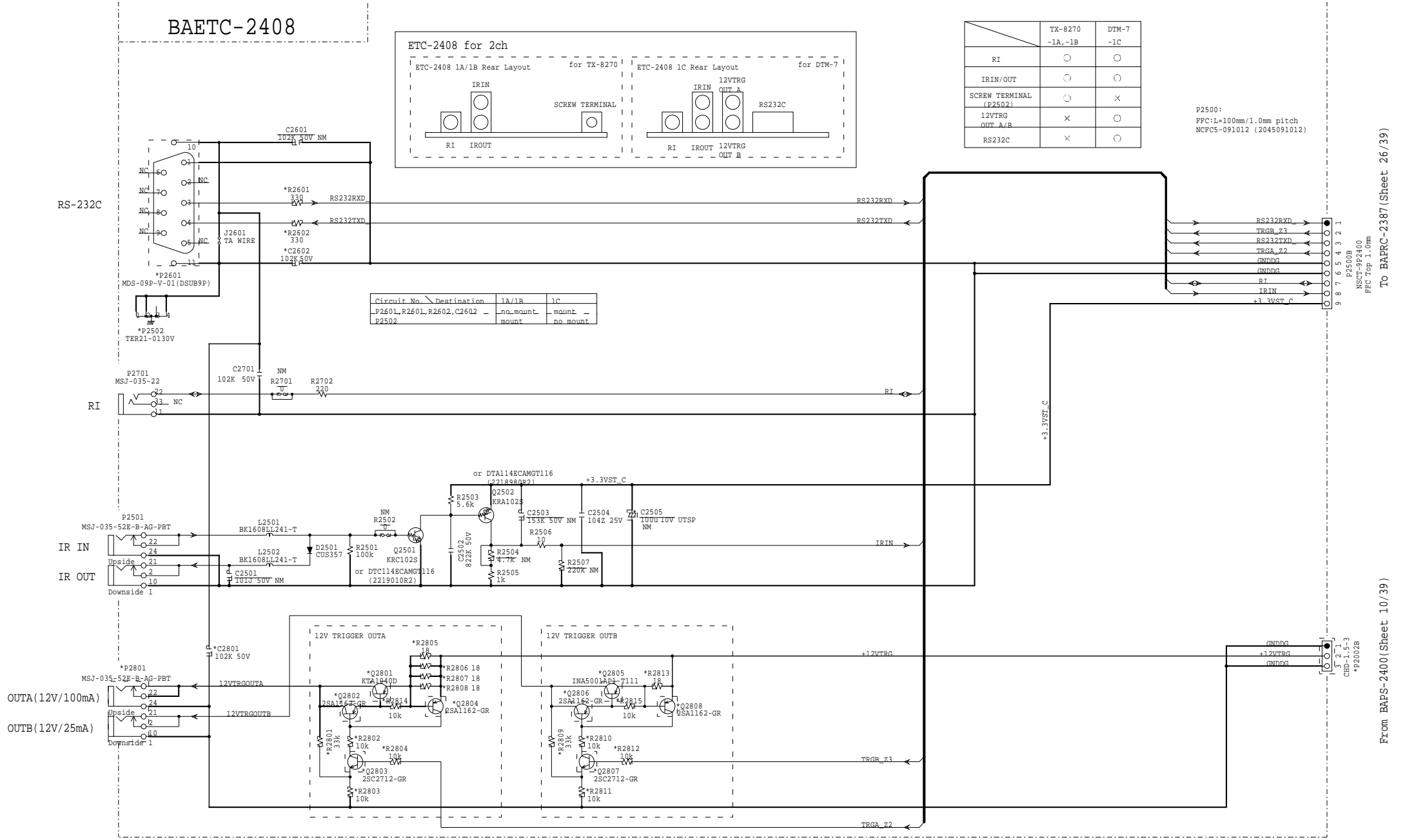

9 8 7 6 5 4 3 2 1  
P2500B  
NCF5-091012  
FFC Top 1.0mm

3 2 1  
GNDG  
+12VTRG  
GNDG

To BAPRC-2387 (Sheet 26/39)  
From BAPS-2400 (Sheet 10/39)





# PART-10 INPUT/BASS SWITCH

# Schematic Diagram

BADIS-2395

TO BADIS-2394 (PART10 Sheet-17/38)

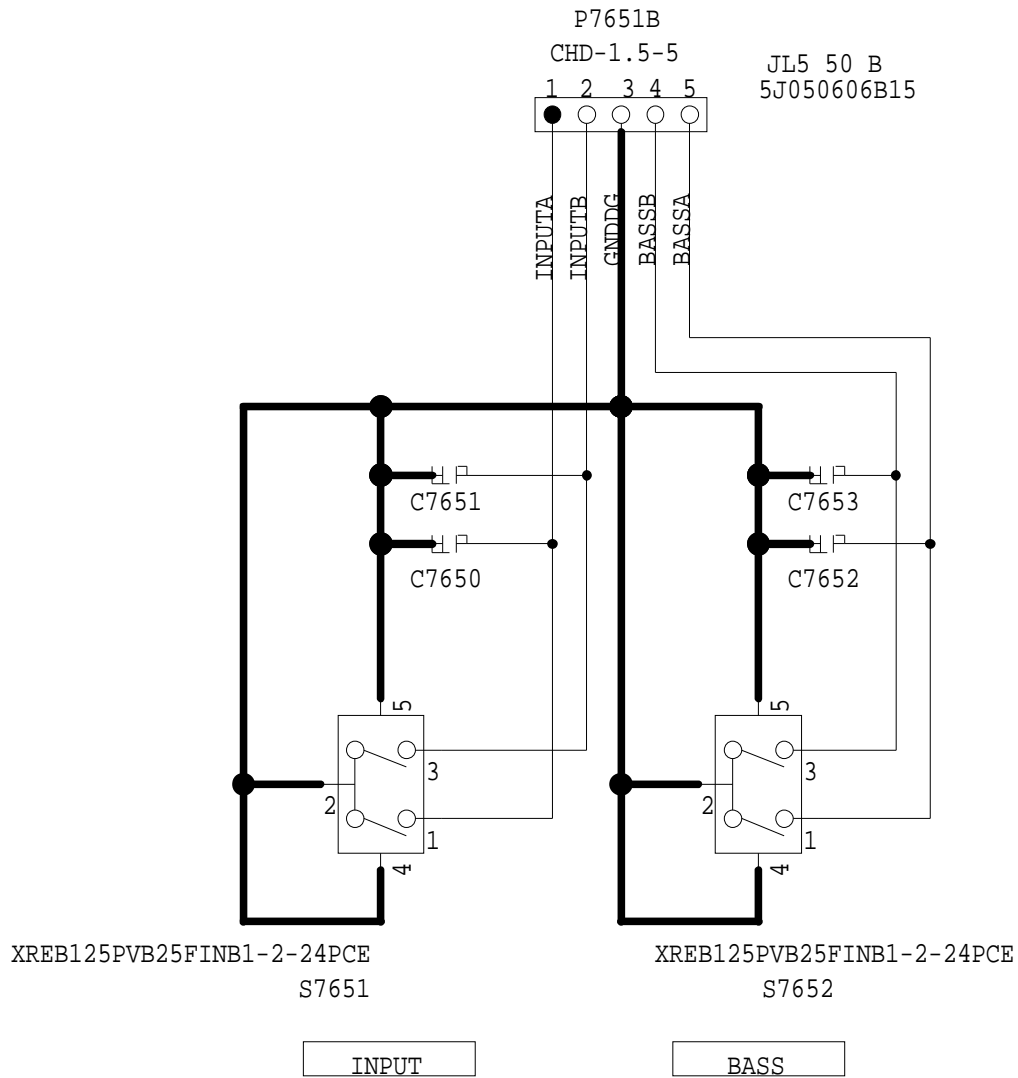

PART-10 TREBLE/BALANCE SWITCH

BASW-2396

TO BADIS-2394 (PART10 Sheet-17/38)

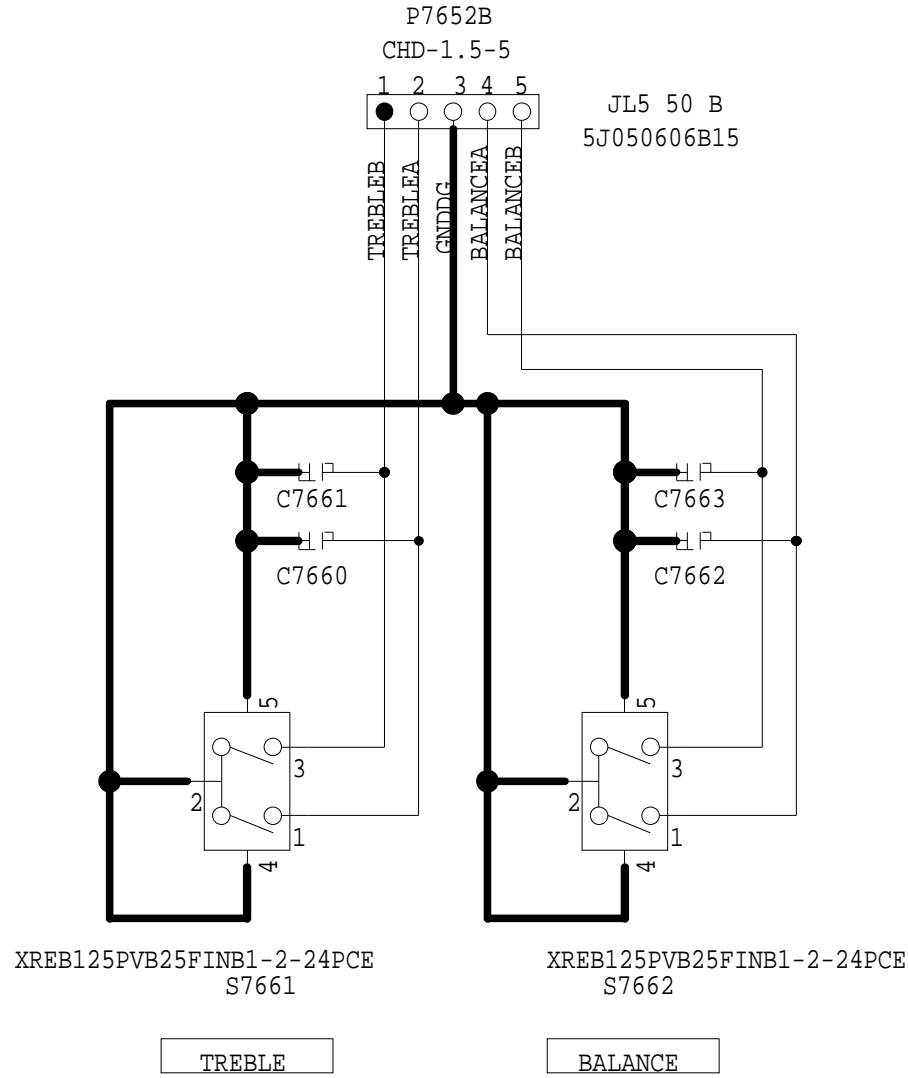

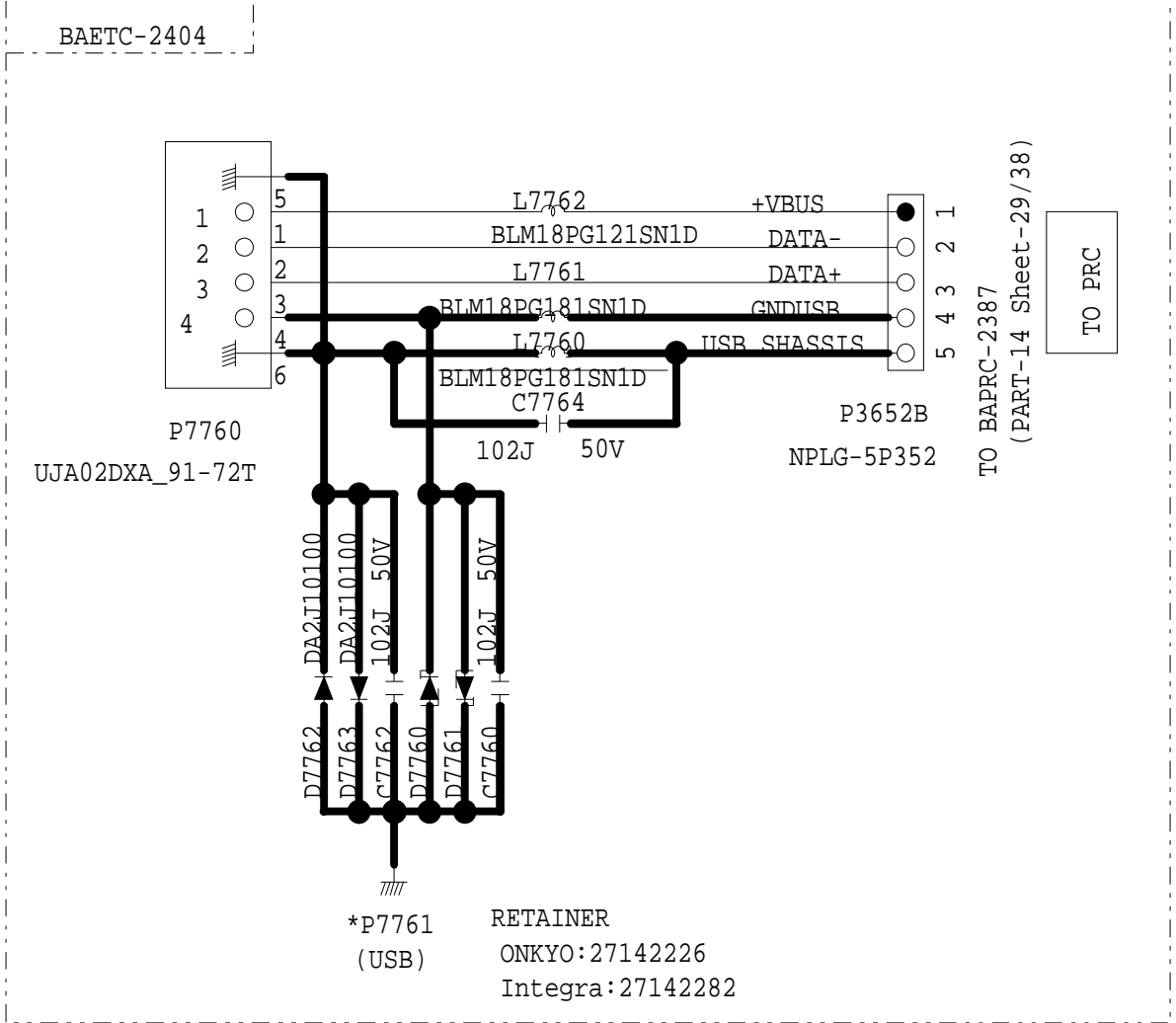

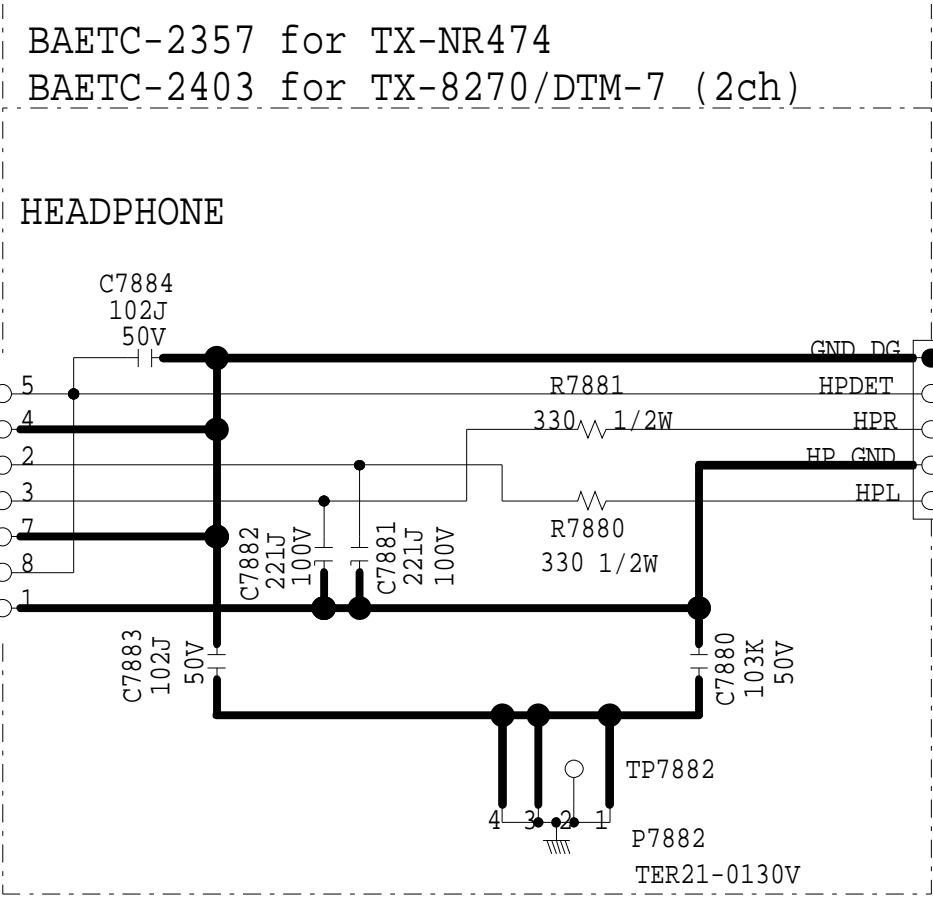

**TO AF**

P7881:

Model	Rating	Color
TX-NR474	MSJ-064-05A SR	Silver
TX-8270 DTM-7	MSJ-064-05A GR	Gold

# PART-13 DIGITAL AUDIO + VLSC2

# Schematic Diagram

BADG-2354/2363/2382/2401

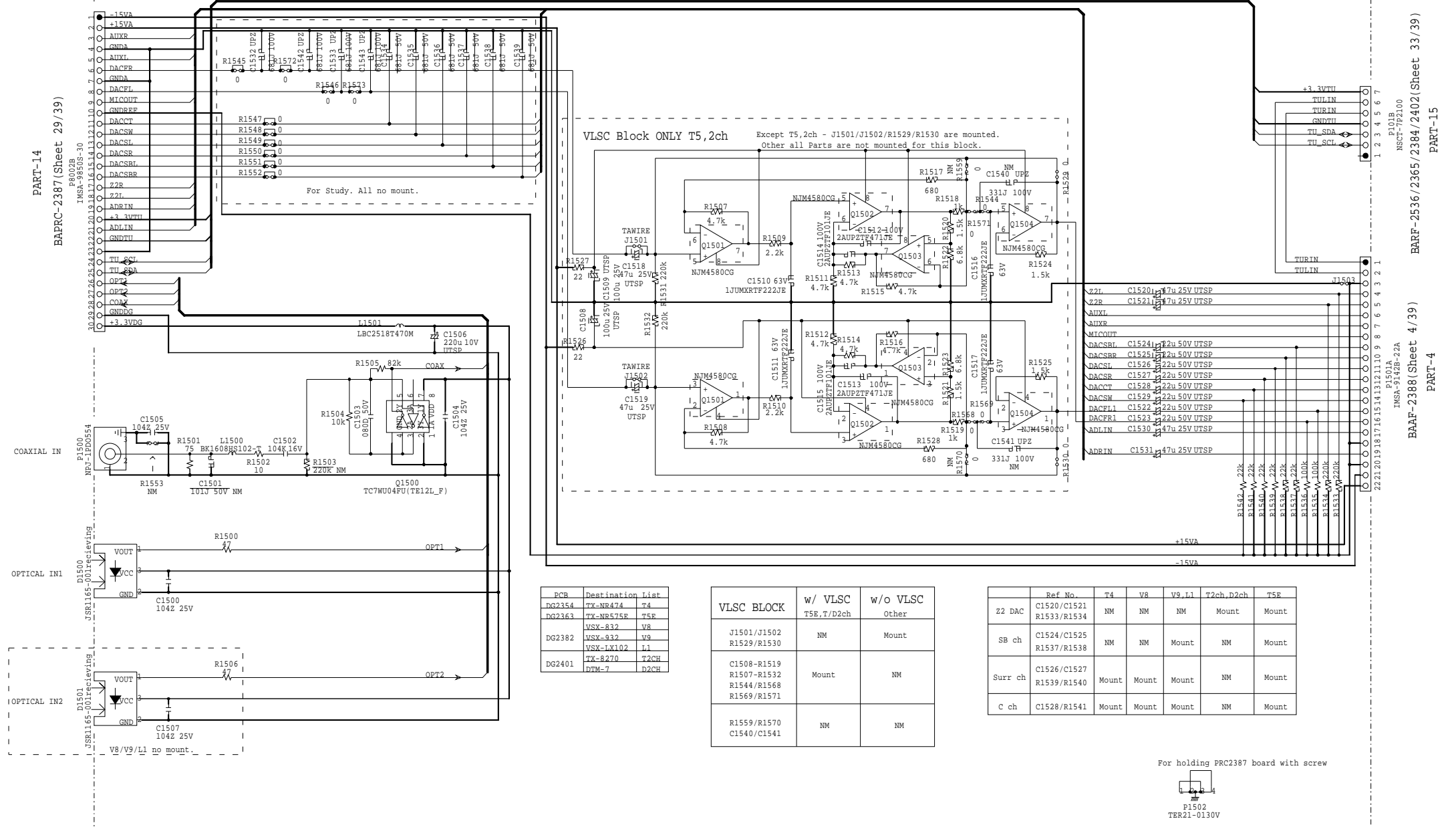

For Study. All no mount.

VLSC Block ONLY T5,2ch  
Except T5,2ch - J1501/J1502/R1529/R1530 are mounted.  
Other all Parts are not mounted for this block.

PCB	Destination List
DG2354	TX-NR474 T4
DG2363	TX-NR575P T5P
DG2382	VXS-832 V8
	VXS-932 V9
DG2401	VXS-LX102 L1
	TX-8270 T2CH
	DTM-7 D2CH

VLSC BLOCK	w/ VLSC T5E,T/D2ch	w/o VLSC Other
J1501/J1502 R1529/R1530	NM	Mount
C1508-R1519 R1507-R1532 R1544/R1568 R1569/R1571	Mount	NM
R1559/R1570 C1540/C1541	NM	NM

	Ref. No.	T4	V8	V9, I1	T2ch, D2ch	T5P
22 DAC	C1520/C1521 R1533/R1534	NM	NM	NM	Mount	Mount
SB ch	C1524/C1525 R1537/R1538	NM	NM	Mount	NM	Mount
Surr ch	C1526/C1527 R1539/R1540	Mount	Mount	Mount	NM	Mount
C ch	C1528/R1541	Mount	Mount	Mount	NM	Mount

For holding PRC2387 board with screw



BAPRC-2387 (Sheet 29/39) P8002B INSA-9850S-30  
 BAAF-2388 (Sheet 4/39) INSA-9142B-22A  
 BARF-2536/2365/2384/2402 (Sheet 33/39) NSCT-7P2100  
 PART-14 PART-15 PART-4

BAPRC-2387 (1/7)

△印は危険、感電の危険に則する取組の爲、必ず指定部品を使用の事。・記入無きコンデンサの値は下記である。  
 電圧印は絶縁抵抗に用いた漏れ電圧を示す。(PART-14内)  
 (4桁、入力抵抗値は4桁以上で電圧値)  
 ・記入無き抵抗値は「R」の付いた値である。  
 ・記入無きコンデンサの単位は「pF」である。  
 例) 0.1 → 0.1pF 100 → 100pF 331 → 330kΩ 333 → 33kΩ  
 ※電子レンジ等において、本図は形式名が不明である。  
 ① 印刷誤り  
 ・本図は形式名が不明につき仕様変更等により予告なく変更する事がある。

F/W MAIN\_UPC P7501  
 F/W MAIN\_J-TAG P7502

P7000 2MSB-MSB-15A  
 DIR/DAC SECT.  
 NET SECT.  
 VSP SECT.  
 DSP SECT.  
 VMPU SECT.

POWER SECT.  
 POK\_M001  
 POK\_M002  
 POK\_M003  
 POK\_M004  
 POK\_M005  
 POK\_M006  
 POK\_M007  
 POK\_M008  
 POK\_M009  
 POK\_M010  
 POK\_M011  
 POK\_M012  
 POK\_M013  
 POK\_M014  
 POK\_M015  
 POK\_M016  
 POK\_M017  
 POK\_M018  
 POK\_M019  
 POK\_M020  
 POK\_M021  
 POK\_M022  
 POK\_M023  
 POK\_M024  
 POK\_M025  
 POK\_M026  
 POK\_M027  
 POK\_M028  
 POK\_M029  
 POK\_M030  
 POK\_M031  
 POK\_M032  
 POK\_M033  
 POK\_M034  
 POK\_M035  
 POK\_M036  
 POK\_M037  
 POK\_M038  
 POK\_M039  
 POK\_M040  
 POK\_M041  
 POK\_M042  
 POK\_M043  
 POK\_M044  
 POK\_M045  
 POK\_M046  
 POK\_M047  
 POK\_M048  
 POK\_M049  
 POK\_M050  
 POK\_M051  
 POK\_M052  
 POK\_M053  
 POK\_M054  
 POK\_M055  
 POK\_M056  
 POK\_M057  
 POK\_M058  
 POK\_M059  
 POK\_M060  
 POK\_M061  
 POK\_M062  
 POK\_M063  
 POK\_M064  
 POK\_M065  
 POK\_M066  
 POK\_M067  
 POK\_M068  
 POK\_M069  
 POK\_M070  
 POK\_M071  
 POK\_M072  
 POK\_M073  
 POK\_M074  
 POK\_M075  
 POK\_M076  
 POK\_M077  
 POK\_M078  
 POK\_M079  
 POK\_M080  
 POK\_M081  
 POK\_M082  
 POK\_M083  
 POK\_M084  
 POK\_M085  
 POK\_M086  
 POK\_M087  
 POK\_M088  
 POK\_M089  
 POK\_M090  
 POK\_M091  
 POK\_M092  
 POK\_M093  
 POK\_M094  
 POK\_M095  
 POK\_M096  
 POK\_M097  
 POK\_M098  
 POK\_M099  
 POK\_M100  
 POK\_M101  
 POK\_M102  
 POK\_M103  
 POK\_M104  
 POK\_M105  
 POK\_M106  
 POK\_M107  
 POK\_M108  
 POK\_M109  
 POK\_M110  
 POK\_M111  
 POK\_M112  
 POK\_M113  
 POK\_M114  
 POK\_M115  
 POK\_M116  
 POK\_M117  
 POK\_M118  
 POK\_M119  
 POK\_M120  
 POK\_M121  
 POK\_M122  
 POK\_M123  
 POK\_M124  
 POK\_M125  
 POK\_M126  
 POK\_M127  
 POK\_M128  
 POK\_M129  
 POK\_M130  
 POK\_M131  
 POK\_M132  
 POK\_M133  
 POK\_M134  
 POK\_M135  
 POK\_M136  
 POK\_M137  
 POK\_M138  
 POK\_M139  
 POK\_M140  
 POK\_M141  
 POK\_M142  
 POK\_M143  
 POK\_M144  
 POK\_M145  
 POK\_M146  
 POK\_M147  
 POK\_M148  
 POK\_M149  
 POK\_M150  
 POK\_M151  
 POK\_M152  
 POK\_M153  
 POK\_M154  
 POK\_M155  
 POK\_M156  
 POK\_M157  
 POK\_M158  
 POK\_M159  
 POK\_M160  
 POK\_M161  
 POK\_M162  
 POK\_M163  
 POK\_M164  
 POK\_M165  
 POK\_M166  
 POK\_M167  
 POK\_M168  
 POK\_M169  
 POK\_M170  
 POK\_M171  
 POK\_M172  
 POK\_M173  
 POK\_M174  
 POK\_M175  
 POK\_M176  
 POK\_M177  
 POK\_M178  
 POK\_M179  
 POK\_M180  
 POK\_M181  
 POK\_M182  
 POK\_M183  
 POK\_M184  
 POK\_M185  
 POK\_M186  
 POK\_M187  
 POK\_M188  
 POK\_M189  
 POK\_M190  
 POK\_M191  
 POK\_M192  
 POK\_M193  
 POK\_M194  
 POK\_M195  
 POK\_M196  
 POK\_M197  
 POK\_M198  
 POK\_M199  
 POK\_M200  
 POK\_M201  
 POK\_M202  
 POK\_M203  
 POK\_M204  
 POK\_M205  
 POK\_M206  
 POK\_M207  
 POK\_M208  
 POK\_M209  
 POK\_M210  
 POK\_M211  
 POK\_M212  
 POK\_M213  
 POK\_M214  
 POK\_M215  
 POK\_M216  
 POK\_M217  
 POK\_M218  
 POK\_M219  
 POK\_M220  
 POK\_M221  
 POK\_M222  
 POK\_M223  
 POK\_M224  
 POK\_M225  
 POK\_M226  
 POK\_M227  
 POK\_M228  
 POK\_M229  
 POK\_M230  
 POK\_M231  
 POK\_M232  
 POK\_M233  
 POK\_M234  
 POK\_M235  
 POK\_M236  
 POK\_M237  
 POK\_M238  
 POK\_M239  
 POK\_M240  
 POK\_M241  
 POK\_M242  
 POK\_M243  
 POK\_M244  
 POK\_M245  
 POK\_M246  
 POK\_M247  
 POK\_M248  
 POK\_M249  
 POK\_M250  
 POK\_M251  
 POK\_M252  
 POK\_M253  
 POK\_M254  
 POK\_M255  
 POK\_M256  
 POK\_M257  
 POK\_M258  
 POK\_M259  
 POK\_M260  
 POK\_M261  
 POK\_M262  
 POK\_M263  
 POK\_M264  
 POK\_M265  
 POK\_M266  
 POK\_M267  
 POK\_M268  
 POK\_M269  
 POK\_M270  
 POK\_M271  
 POK\_M272  
 POK\_M273  
 POK\_M274  
 POK\_M275  
 POK\_M276  
 POK\_M277  
 POK\_M278  
 POK\_M279  
 POK\_M280  
 POK\_M281  
 POK\_M282  
 POK\_M283  
 POK\_M284  
 POK\_M285  
 POK\_M286  
 POK\_M287  
 POK\_M288  
 POK\_M289  
 POK\_M290  
 POK\_M291  
 POK\_M292  
 POK\_M293  
 POK\_M294  
 POK\_M295  
 POK\_M296  
 POK\_M297  
 POK\_M298  
 POK\_M299  
 POK\_M300  
 POK\_M301  
 POK\_M302  
 POK\_M303  
 POK\_M304  
 POK\_M305  
 POK\_M306  
 POK\_M307  
 POK\_M308  
 POK\_M309  
 POK\_M310  
 POK\_M311  
 POK\_M312  
 POK\_M313  
 POK\_M314  
 POK\_M315  
 POK\_M316  
 POK\_M317  
 POK\_M318  
 POK\_M319  
 POK\_M320  
 POK\_M321  
 POK\_M322  
 POK\_M323  
 POK\_M324  
 POK\_M325  
 POK\_M326  
 POK\_M327  
 POK\_M328  
 POK\_M329  
 POK\_M330  
 POK\_M331  
 POK\_M332  
 POK\_M333  
 POK\_M334  
 POK\_M335  
 POK\_M336  
 POK\_M337  
 POK\_M338  
 POK\_M339  
 POK\_M340  
 POK\_M341  
 POK\_M342  
 POK\_M343  
 POK\_M344  
 POK\_M345  
 POK\_M346  
 POK\_M347  
 POK\_M348  
 POK\_M349  
 POK\_M350  
 POK\_M351  
 POK\_M352  
 POK\_M353  
 POK\_M354  
 POK\_M355  
 POK\_M356  
 POK\_M357  
 POK\_M358  
 POK\_M359  
 POK\_M360  
 POK\_M361  
 POK\_M362  
 POK\_M363  
 POK\_M364  
 POK\_M365  
 POK\_M366  
 POK\_M367  
 POK\_M368  
 POK\_M369  
 POK\_M370  
 POK\_M371  
 POK\_M372  
 POK\_M373  
 POK\_M374  
 POK\_M375  
 POK\_M376  
 POK\_M377  
 POK\_M378  
 POK\_M379  
 POK\_M380  
 POK\_M381  
 POK\_M382  
 POK\_M383  
 POK\_M384  
 POK\_M385  
 POK\_M386  
 POK\_M387  
 POK\_M388  
 POK\_M389  
 POK\_M390  
 POK\_M391  
 POK\_M392  
 POK\_M393  
 POK\_M394  
 POK\_M395  
 POK\_M396  
 POK\_M397  
 POK\_M398  
 POK\_M399  
 POK\_M400  
 POK\_M401  
 POK\_M402  
 POK\_M403  
 POK\_M404  
 POK\_M405  
 POK\_M406  
 POK\_M407  
 POK\_M408  
 POK\_M409  
 POK\_M410  
 POK\_M411  
 POK\_M412  
 POK\_M413  
 POK\_M414  
 POK\_M415  
 POK\_M416  
 POK\_M417  
 POK\_M418  
 POK\_M419  
 POK\_M420  
 POK\_M421  
 POK\_M422  
 POK\_M423  
 POK\_M424  
 POK\_M425  
 POK\_M426  
 POK\_M427  
 POK\_M428  
 POK\_M429  
 POK\_M430  
 POK\_M431  
 POK\_M432  
 POK\_M433  
 POK\_M434  
 POK\_M435  
 POK\_M436  
 POK\_M437  
 POK\_M438  
 POK\_M439  
 POK\_M440  
 POK\_M441  
 POK\_M442  
 POK\_M443  
 POK\_M444  
 POK\_M445  
 POK\_M446  
 POK\_M447  
 POK\_M448  
 POK\_M449  
 POK\_M450  
 POK\_M451  
 POK\_M452  
 POK\_M453  
 POK\_M454  
 POK\_M455  
 POK\_M456  
 POK\_M457  
 POK\_M458  
 POK\_M459  
 POK\_M460  
 POK\_M461  
 POK\_M462  
 POK\_M463  
 POK\_M464  
 POK\_M465  
 POK\_M466  
 POK\_M467  
 POK\_M468  
 POK\_M469  
 POK\_M470  
 POK\_M471  
 POK\_M472  
 POK\_M473  
 POK\_M474  
 POK\_M475  
 POK\_M476  
 POK\_M477  
 POK\_M478  
 POK\_M479  
 POK\_M480  
 POK\_M481  
 POK\_M482  
 POK\_M483  
 POK\_M484  
 POK\_M485  
 POK\_M486  
 POK\_M487  
 POK\_M488  
 POK\_M489  
 POK\_M490  
 POK\_M491  
 POK\_M492  
 POK\_M493  
 POK\_M494  
 POK\_M495  
 POK\_M496  
 POK\_M497  
 POK\_M498  
 POK\_M499  
 POK\_M500  
 POK\_M501  
 POK\_M502  
 POK\_M503  
 POK\_M504  
 POK\_M505  
 POK\_M506  
 POK\_M507  
 POK\_M508  
 POK\_M509  
 POK\_M510  
 POK\_M511  
 POK\_M512  
 POK\_M513  
 POK\_M514  
 POK\_M515  
 POK\_M516  
 POK\_M517  
 POK\_M518  
 POK\_M519  
 POK\_M520  
 POK\_M521  
 POK\_M522  
 POK\_M523  
 POK\_M524  
 POK\_M525  
 POK\_M526  
 POK\_M527  
 POK\_M528  
 POK\_M529  
 POK\_M530  
 POK\_M531  
 POK\_M532  
 POK\_M533  
 POK\_M534  
 POK\_M535  
 POK\_M536  
 POK\_M537  
 POK\_M538  
 POK\_M539  
 POK\_M540  
 POK\_M541  
 POK\_M542  
 POK\_M543  
 POK\_M544  
 POK\_M545  
 POK\_M546  
 POK\_M547  
 POK\_M548  
 POK\_M549  
 POK\_M550  
 POK\_M551  
 POK\_M552  
 POK\_M553  
 POK\_M554  
 POK\_M555  
 POK\_M556  
 POK\_M557  
 POK\_M558  
 POK\_M559  
 POK\_M560  
 POK\_M561  
 POK\_M562  
 POK\_M563  
 POK\_M564  
 POK\_M565  
 POK\_M566  
 POK\_M567  
 POK\_M568  
 POK\_M569  
 POK\_M570  
 POK\_M571  
 POK\_M572  
 POK\_M573  
 POK\_M574  
 POK\_M575  
 POK\_M576  
 POK\_M577  
 POK\_M578  
 POK\_M579  
 POK\_M580  
 POK\_M581  
 POK\_M582  
 POK\_M583  
 POK\_M584  
 POK\_M585  
 POK\_M586  
 POK\_M587  
 POK\_M588  
 POK\_M589  
 POK\_M590  
 POK\_M591  
 POK\_M592  
 POK\_M593  
 POK\_M594  
 POK\_M595  
 POK\_M596  
 POK\_M597  
 POK\_M598  
 POK\_M599  
 POK\_M600  
 POK\_M601  
 POK\_M602  
 POK\_M603  
 POK\_M604  
 POK\_M605  
 POK\_M606  
 POK\_M607  
 POK\_M608  
 POK\_M609  
 POK\_M610  
 POK\_M611  
 POK\_M612  
 POK\_M613  
 POK\_M614  
 POK\_M615  
 POK\_M616  
 POK\_M617  
 POK\_M618  
 POK\_M619  
 POK\_M620  
 POK\_M621  
 POK\_M622  
 POK\_M623  
 POK\_M624  
 POK\_M625  
 POK\_M626  
 POK\_M627  
 POK\_M628  
 POK\_M629  
 POK\_M630  
 POK\_M631  
 POK\_M632  
 POK\_M633  
 POK\_M634  
 POK\_M635  
 POK\_M636  
 POK\_M637  
 POK\_M638  
 POK\_M639  
 POK\_M640  
 POK\_M641  
 POK\_M642  
 POK\_M643  
 POK\_M644  
 POK\_M645  
 POK\_M646  
 POK\_M647  
 POK\_M648  
 POK\_M649  
 POK\_M650  
 POK\_M651  
 POK\_M652  
 POK\_M653  
 POK\_M654  
 POK\_M655  
 POK\_M656  
 POK\_M657  
 POK\_M658  
 POK\_M659  
 POK\_M660  
 POK\_M661  
 POK\_M662  
 POK\_M663  
 POK\_M664  
 POK\_M665  
 POK\_M666  
 POK\_M667  
 POK\_M668  
 POK\_M669  
 POK\_M670  
 POK\_M671  
 POK\_M672  
 POK\_M673  
 POK\_M674  
 POK\_M675  
 POK\_M676  
 POK\_M677  
 POK\_M678  
 POK\_M679  
 POK\_M680  
 POK\_M681  
 POK\_M682  
 POK\_M683  
 POK\_M684  
 POK\_M685  
 POK\_M686  
 POK\_M687  
 POK\_M688  
 POK\_M689  
 POK\_M690  
 POK\_M691  
 POK\_M692  
 POK\_M693  
 POK\_M694  
 POK\_M695  
 POK\_M696  
 POK\_M697  
 POK\_M698  
 POK\_M699  
 POK\_M700  
 POK\_M701  
 POK\_M702  
 POK\_M703  
 POK\_M704  
 POK\_M705  
 POK\_M706  
 POK\_M707  
 POK\_M708  
 POK\_M709  
 POK\_M710  
 POK\_M711  
 POK\_M712  
 POK\_M713  
 POK\_M714  
 POK\_M715  
 POK\_M716  
 POK\_M717  
 POK\_M718  
 POK\_M719  
 POK\_M720  
 POK\_M721  
 POK\_M722  
 POK\_M723  
 POK\_M724  
 POK\_M725  
 POK\_M726  
 POK\_M727  
 POK\_M728  
 POK\_M729  
 POK\_M730  
 POK\_M731  
 POK\_M732  
 POK\_M733  
 POK\_M734  
 POK\_M735  
 POK\_M736  
 POK\_M737  
 POK\_M738  
 POK\_M739  
 POK\_M740  
 POK\_M741  
 POK\_M742  
 POK\_M743  
 POK\_M744  
 POK\_M745  
 POK\_M746  
 POK\_M747  
 POK\_M748  
 POK\_M749  
 POK\_M750  
 POK\_M751  
 POK\_M752  
 POK\_M753  
 POK\_M754  
 POK\_M755  
 POK\_M756  
 POK\_M757  
 POK\_M758  
 POK\_M759  
 POK\_M760  
 POK\_M761  
 POK\_M762  
 POK\_M763  
 POK\_M764  
 POK\_M765  
 POK\_M766  
 POK\_M767  
 POK\_M768  
 POK\_M769  
 POK\_M770  
 POK\_M771  
 POK\_M772  
 POK\_M773  
 POK\_M774  
 POK\_M775  
 POK\_M776  
 POK\_M777  
 POK\_M778  
 POK\_M779  
 POK\_M780  
 POK\_M781  
 POK\_M782  
 POK\_M783  
 POK\_M784  
 POK\_M785  
 POK\_M786  
 POK\_M787  
 POK\_M788  
 POK\_M789  
 POK\_M790  
 POK\_M791  
 POK\_M792  
 POK\_M793  
 POK\_M794  
 POK\_M795  
 POK\_M796  
 POK\_M797  
 POK\_M798  
 POK\_M799  
 POK\_M800  
 POK\_M801  
 POK\_M802  
 POK\_M803  
 POK\_M804  
 POK\_M805  
 POK\_M806  
 POK\_M807  
 POK\_M808  
 POK\_M809  
 POK\_M810  
 POK\_M811  
 POK\_M812  
 POK\_M813  
 POK\_M814  
 POK\_M815  
 POK\_M816  
 POK\_M817  
 POK\_M818  
 POK\_M819  
 POK\_M820  
 POK\_M821  
 POK\_M822  
 POK\_M823  
 POK\_M824  
 POK\_M825  
 POK\_M826  
 POK\_M827  
 POK\_M828  
 POK\_M829  
 POK\_M830  
 POK\_M831  
 POK\_M832  
 POK\_M833  
 POK\_M834  
 POK\_M835  
 POK\_M836  
 POK\_M837  
 POK\_M838  
 POK\_M839  
 POK\_M840  
 POK\_M841  
 POK\_M842  
 POK\_M843  
 POK\_M844  
 POK\_M845  
 POK\_M846  
 POK\_M847  
 POK\_M848  
 POK\_M849  
 POK\_M850  
 POK\_M851  
 POK\_M852  
 POK\_M853  
 POK\_M854  
 POK\_M855  
 POK\_M856  
 POK\_M857  
 POK\_M858  
 POK\_M859  
 POK\_M860  
 POK\_M861  
 POK\_M862  
 POK\_M863  
 POK\_M864  
 POK\_M865  
 POK\_M866  
 POK\_M867  
 POK\_M868  
 POK\_M869  
 POK\_M870  
 POK\_M871  
 POK\_M872  
 POK\_M873  
 POK\_M874  
 POK\_M875  
 POK\_M876  
 POK\_M877  
 POK\_M878  
 POK\_M879  
 POK\_M880  
 POK\_M881  
 POK\_M882  
 POK\_M883  
 POK\_M884  
 POK\_M885  
 POK\_M886  
 POK\_M887  
 POK\_M888  
 POK\_M889  
 POK\_M890  
 POK\_M891  
 POK\_M892  
 POK\_M893  
 POK\_M894  
 POK\_M895  
 POK\_M896  
 POK\_M897  
 POK\_M898  
 POK\_M899  
 POK\_M900  
 POK\_M901  
 POK\_M902  
 POK\_M903  
 POK\_M904  
 POK\_M905  
 POK\_M906  
 POK\_M907  
 POK\_M908  
 POK\_M909  
 POK\_M910  
 POK\_M911  
 POK\_M912  
 POK\_M913  
 POK\_M914  
 POK\_M915  
 POK\_M916  
 POK\_M917  
 POK\_M918  
 POK\_M919  
 POK\_M920  
 POK\_M921  
 POK\_M922  
 POK\_M923  
 POK\_M924  
 POK\_M925  
 POK\_M926  
 POK\_M927  
 POK\_M928  
 POK\_M929  
 POK\_M930  
 POK\_M931  
 POK\_M932  
 POK\_M933  
 POK\_M934  
 POK\_M935  
 POK\_M936  
 POK\_M937  
 POK\_M938  
 POK\_M939  
 POK\_M940  
 POK\_M941  
 POK\_M942  
 POK\_M943  
 POK\_M944  
 POK\_M945  
 POK\_M946  
 POK\_M947  
 POK\_M948  
 POK\_M949  
 POK\_M950  
 POK\_M951  
 POK\_M952  
 POK\_M953  
 POK\_M954  
 POK\_M955  
 POK\_M956  
 POK\_M957  
 POK\_M958  
 POK\_M959  
 POK\_M960  
 POK\_M961  
 POK\_M962  
 POK\_M963  
 POK\_M964  
 POK\_M965  
 POK\_M966  
 POK\_M967  
 POK\_M968  
 POK\_M969  
 POK\_M970  
 POK\_M971  
 POK\_M972  
 POK\_M973  
 POK\_M974  
 POK\_M975  
 POK\_M976  
 POK\_M977  
 POK\_M978  
 POK\_M979  
 POK\_M980  
 POK\_M981  
 POK\_M982  
 POK\_M983  
 POK\_M984  
 POK\_M985  
 POK\_M986  
 POK\_M987  
 POK\_M988  
 POK\_M989  
 POK\_M990  
 POK\_M991  
 POK\_M992  
 POK\_M993  
 POK\_M994  
 POK\_M995  
 POK\_M996  
 POK\_M997  
 POK\_M998  
 POK\_M999  
 POK\_M1000

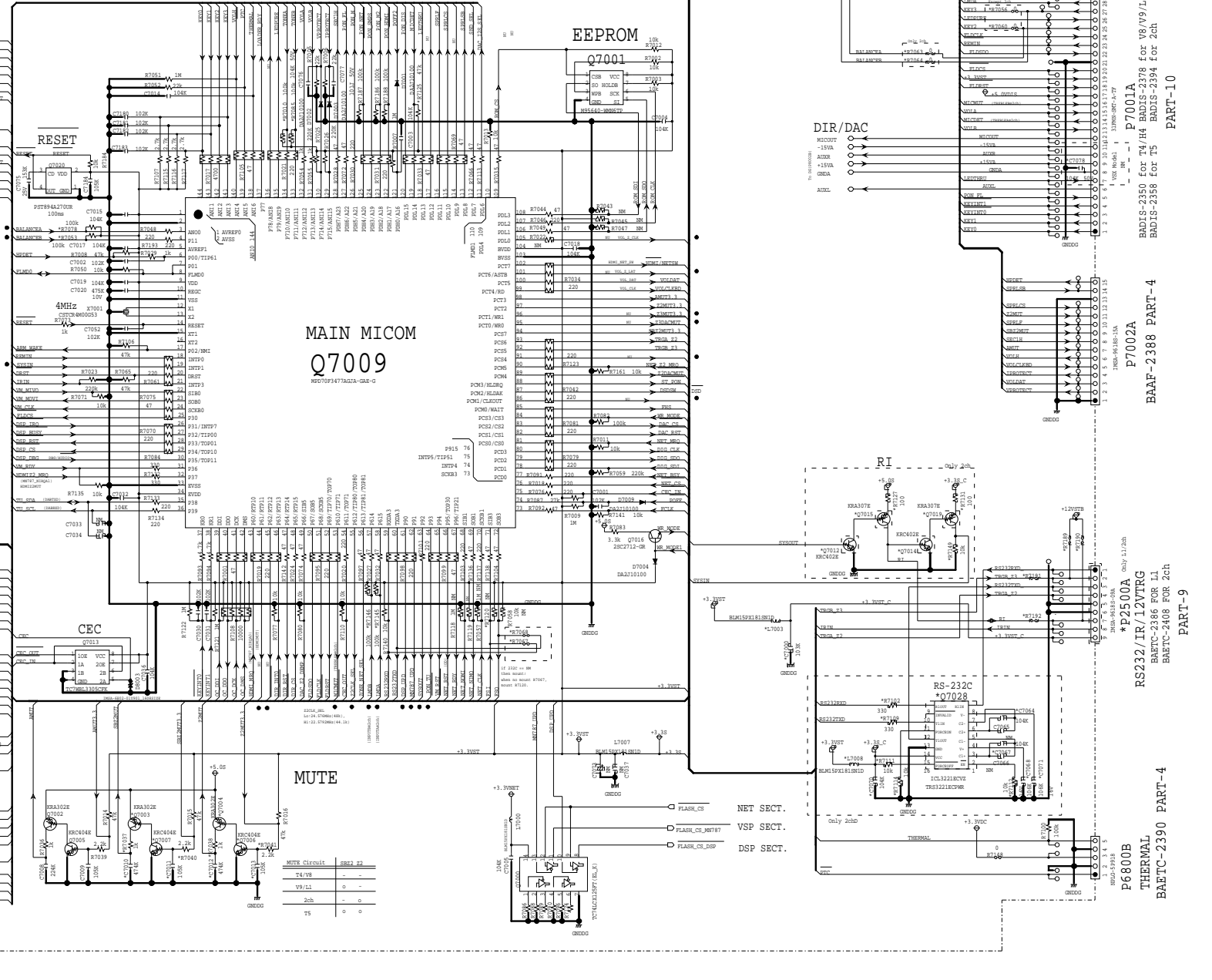

MAIN MICOM  
 Q7009  
 HQ7093473A7A-GR-G

EEPROM  
 Q7001

RS-232C  
 Q7028

MUTE  
 MUTE Circuit

RI

RS232C

RS-232C  
 Q7028

THERMAL

P7001A  
 RADIS-2350 for T4/H4  
 RADIS-2378 for V8/V9/L1  
 RADIS-2358 for T5  
 PART-10

P7002A  
 BAAF-2388  
 PART-4

\*P2500A  
 RS232C/IR/LZVTRG  
 BAPRC-2386 FOR L1  
 BAPRC-2408 FOR 2ch  
 PART-9

P6800B  
 THERMAL  
 BAETC-2390  
 PART-4

BAPRC-2387 (2/7)

VMPU write P8702  
P8703 For Debug

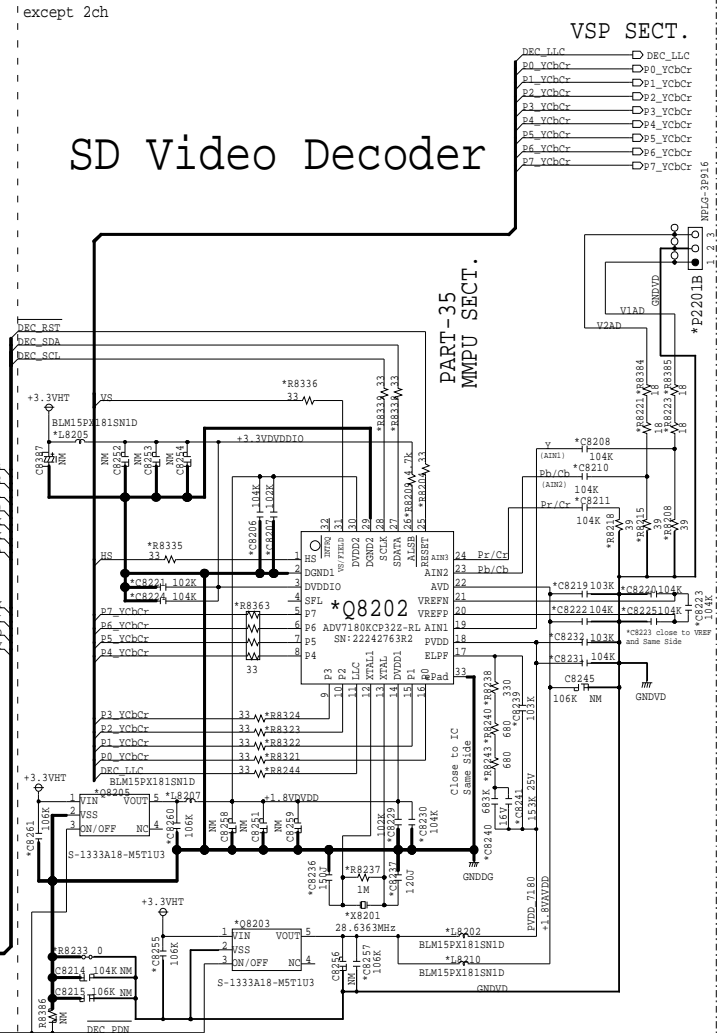
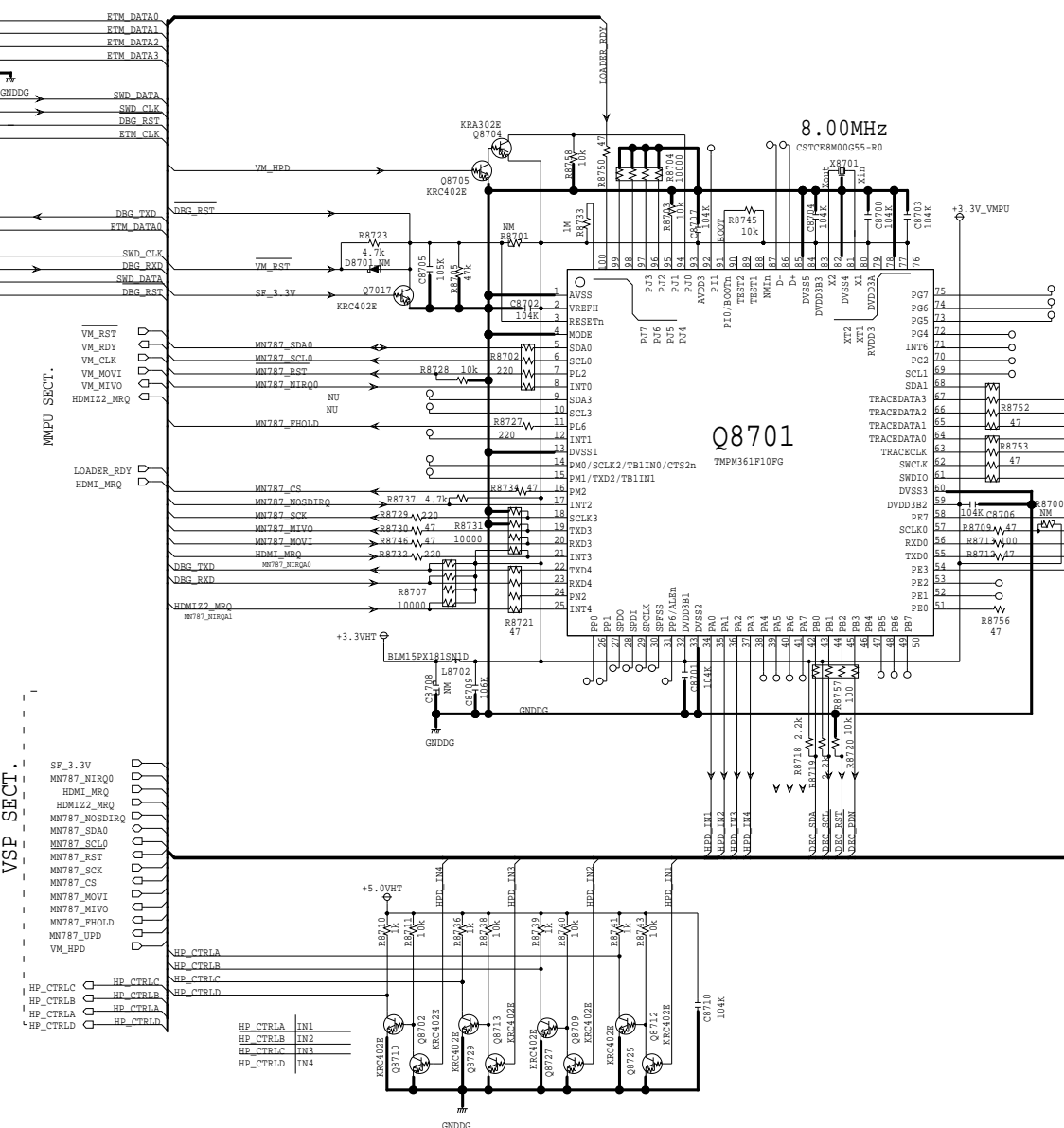

- VSP SECT.
- DEC\_ILIC
  - P0\_YbCr
  - P1\_YbCr
  - P2\_YbCr
  - P3\_YbCr
  - P4\_YbCr
  - P5\_YbCr
  - P6\_YbCr
  - P7\_YbCr

PART-35  
M1PU SECT.

- DEC\_RST
- DEC\_SDA
- DEC\_SCL
- VIAD
- W2AD

- \*C8208
- \*C8210
- \*C8211
- \*C8212
- \*C8213
- \*C8214
- \*C8215
- \*C8216
- \*C8217
- \*C8218
- \*C8219
- \*C8220
- \*C8221
- \*C8222
- \*C8223
- \*C8224
- \*C8225

- \*R8201
- \*R8202
- \*R8203
- \*R8204
- \*R8205
- \*R8206
- \*R8207
- \*R8208
- \*R8209
- \*R8210
- \*R8211
- \*R8212
- \*R8213
- \*R8214
- \*R8215
- \*R8216
- \*R8217
- \*R8218
- \*R8219
- \*R8220
- \*R8221
- \*R8222
- \*R8223
- \*R8224
- \*R8225

- \*C8701
- \*C8702
- \*C8703
- \*C8704
- \*C8705
- \*C8706
- \*C8707
- \*C8708
- \*C8709
- \*C8710

- \*R8701
- \*R8702
- \*R8703
- \*R8704
- \*R8705
- \*R8706
- \*R8707
- \*R8708
- \*R8709
- \*R8710
- \*R8711
- \*R8712
- \*R8713
- \*R8714
- \*R8715
- \*R8716
- \*R8717
- \*R8718
- \*R8719
- \*R8720
- \*R8721
- \*R8722
- \*R8723
- \*R8724
- \*R8725





# PART-14 DIR/DAC

BAPRC-2387 (4/7)

# Schematic Diagram

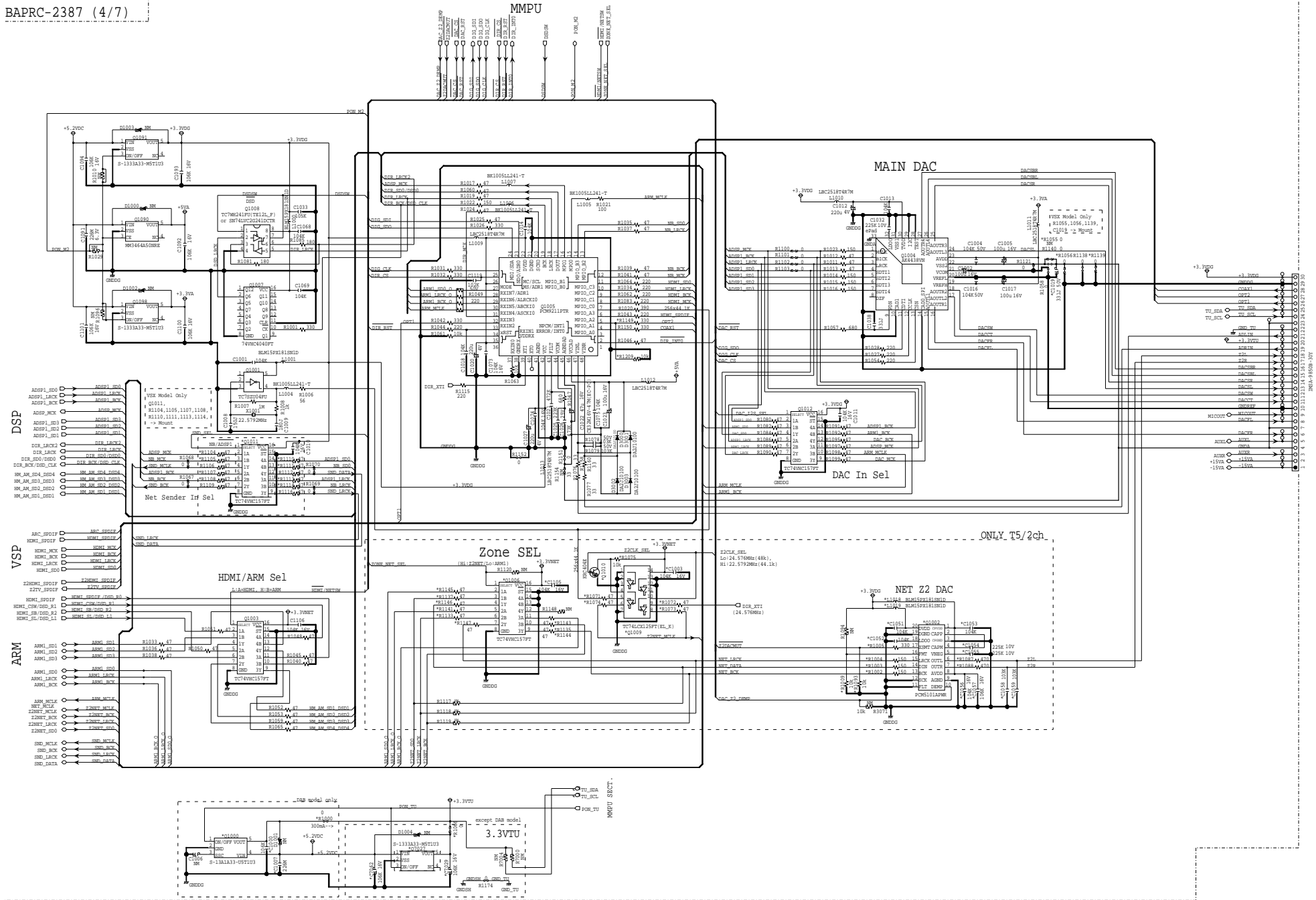

F8002A  
BADG-2354/2363/2382/2401 PART-13



To Network Module(BADG2252-2)

BAPRC-2387 (6/7)

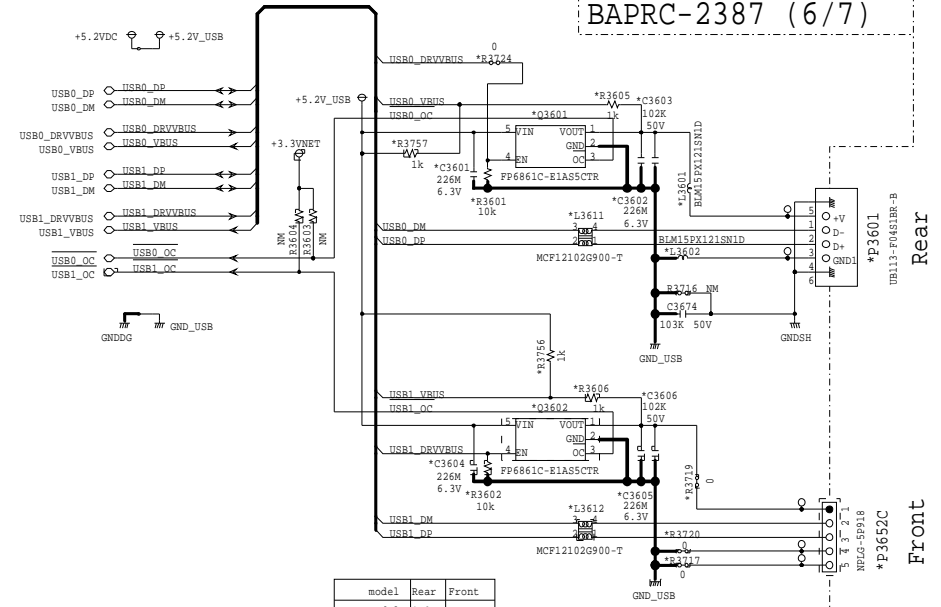
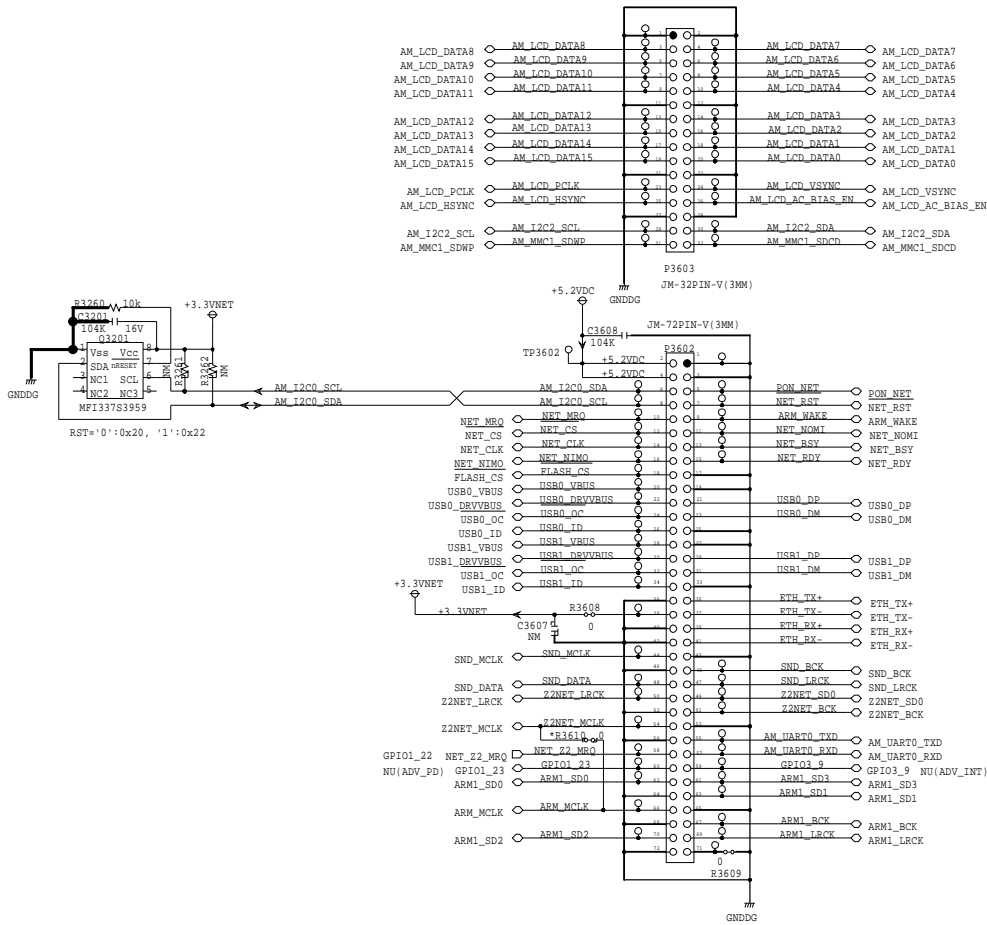

model	Rear	Front
0 model	1.0A	--
P model	0.5A	0.5A
2ch model	0.5A	1.0A

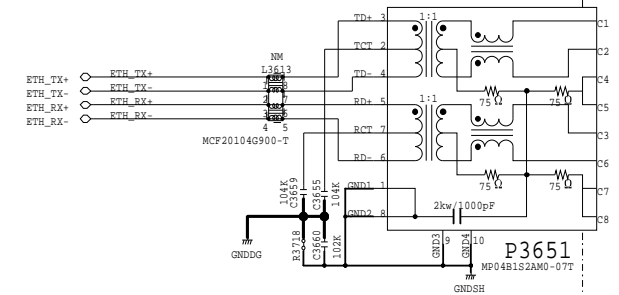



PART-15 TUNER

Schematic Diagram

BARF-2356/2365/2384/2402

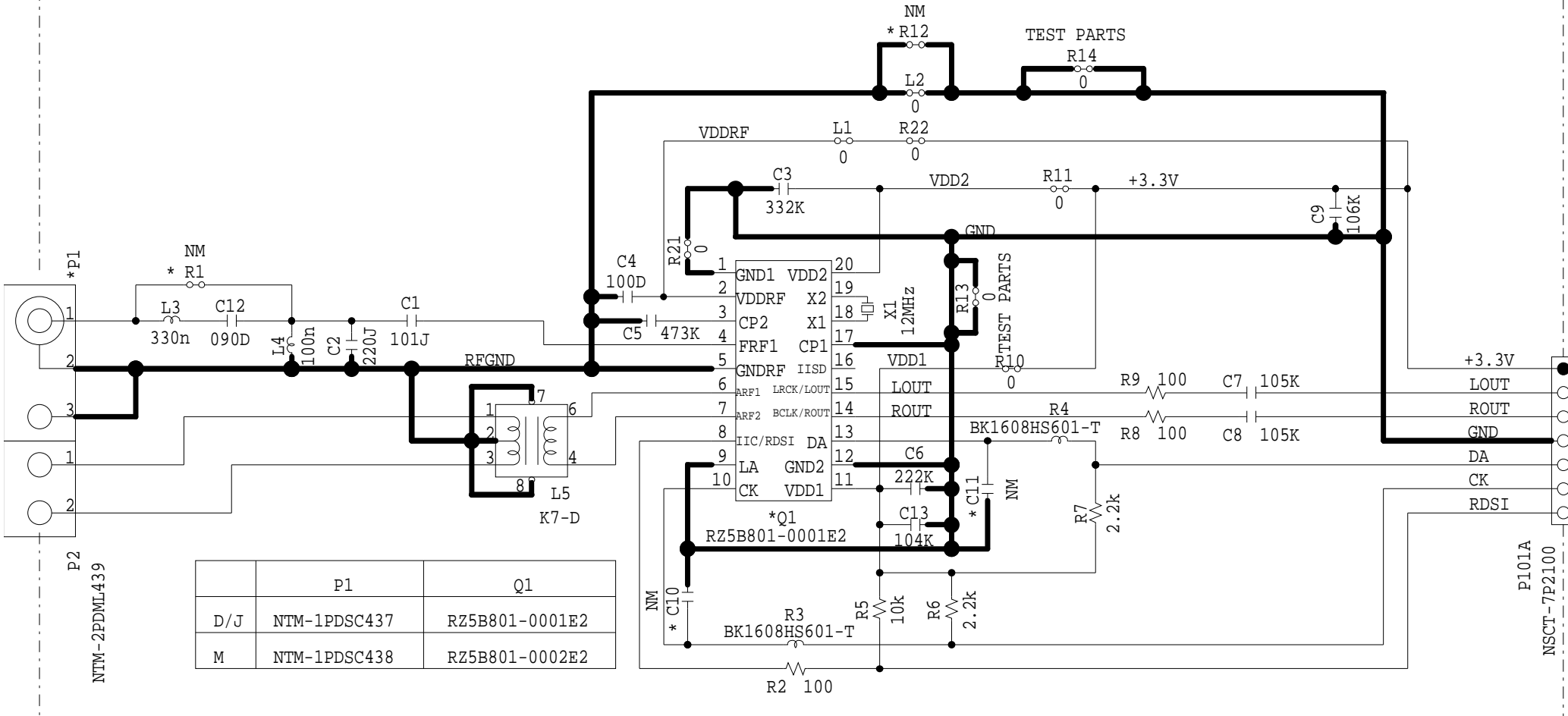

	P1	Q1
D/J	NTM-1PDSC437	RZ5B801-0001E2
M	NTM-1PDSC438	RZ5B801-0002E2

TO BADG-2354/2363/2382/2401 (PART-13)

# PART-16 DAB CONNECTOR(TX-8270)

# Schematic Diagram

BAETC-2405/2406/2407

P2900 or Parts:25053643 C22542-5085-26G

P101:  
FFC:L=150mm/1.25mm pitch  
NCFC7-071512 (2047071512)

Connect to "Verona 2"

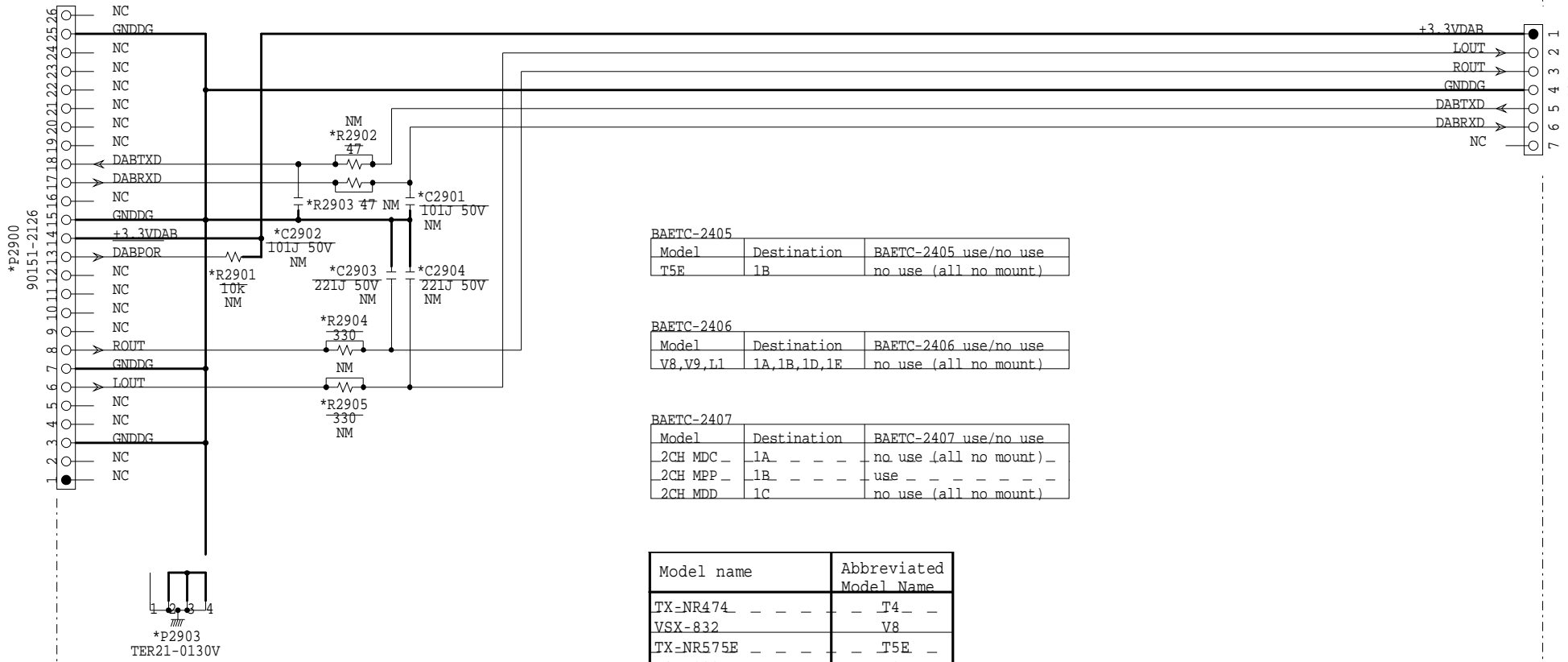

BAETC-2405

Model	Destination	BAETC-2405 use/no use
T5E	1B	no use (all no mount)

BAETC-2406

Model	Destination	BAETC-2406 use/no use
V8, V9, L1	1A, 1B, 1D, 1E	no use (all no mount)

BAETC-2407

Model	Destination	BAETC-2407 use/no use
2CH MDC	1A	no use (all no mount)
2CH MPP	1B	use
2CH MDD	1C	no use (all no mount)

Model name	Abbreviated Model Name
TX-NR474	T4
VSX-832	V8
TX-NR575E	T5E
VSX-932	V9
VSX-LX102	L1
TX-8270	T2CH
DTM-7	D2CH

\*P101C  
NSCT-7P2100  
FFC Top 1.25mm

To DG2354/2363/2382/2401 (Sheet 24/38)



PART-17 ARM PS

BADG-2252 (2/5)

# Schematic Diagram

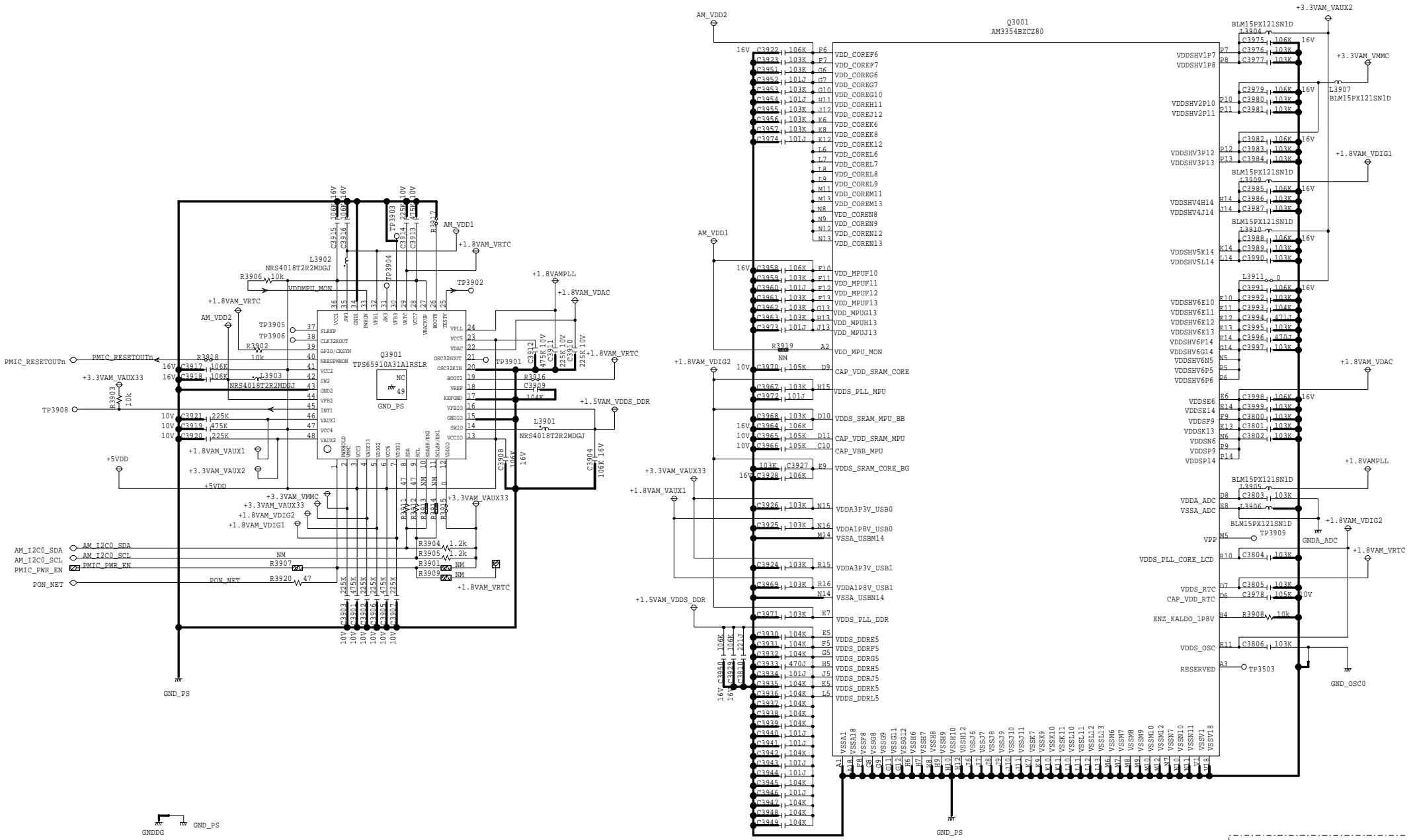



# PART-17 ARM MEMORY

BADG-2252 (3/5)

# Schematic Diagram

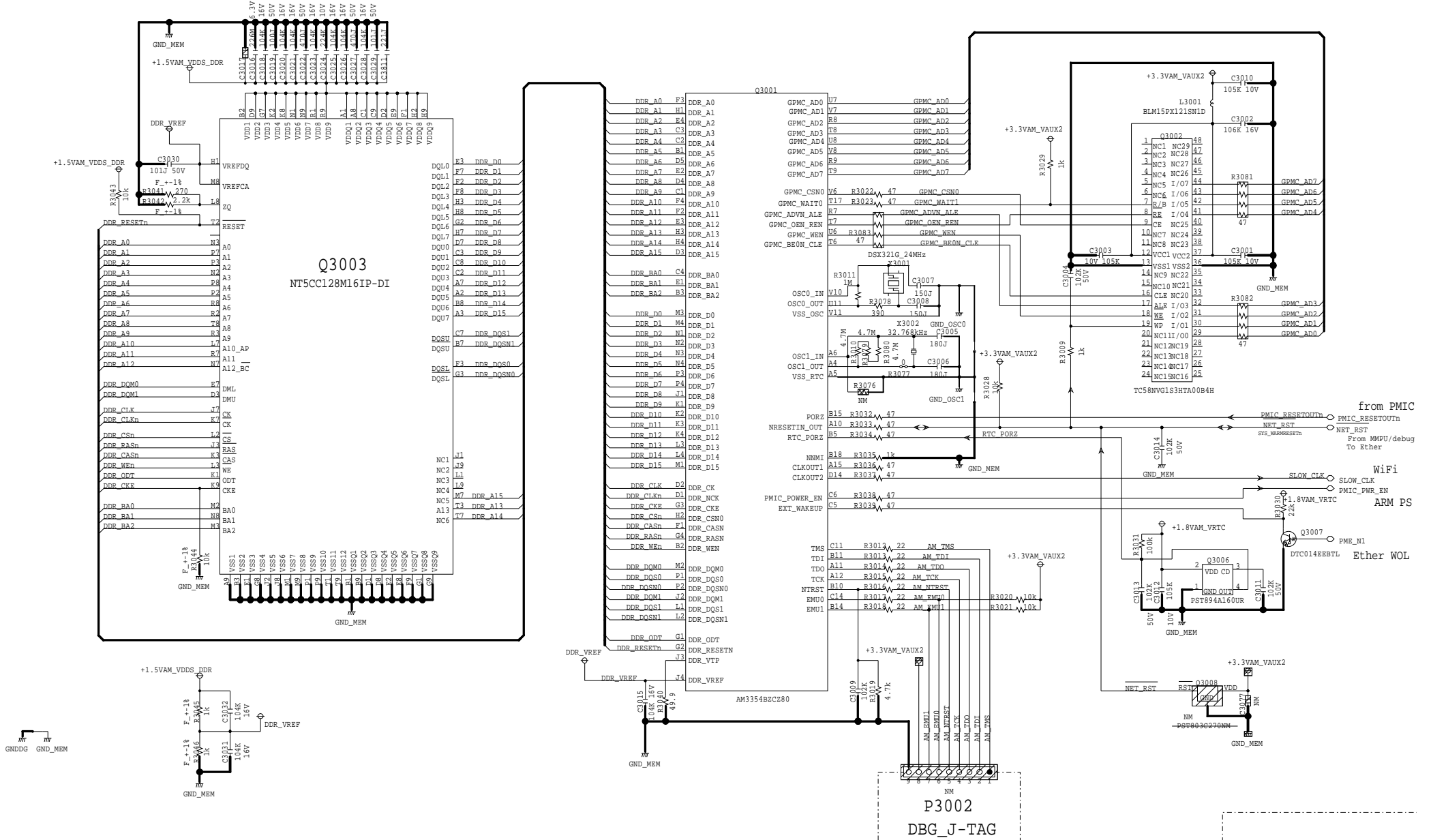

BADG-2252 (4/5)

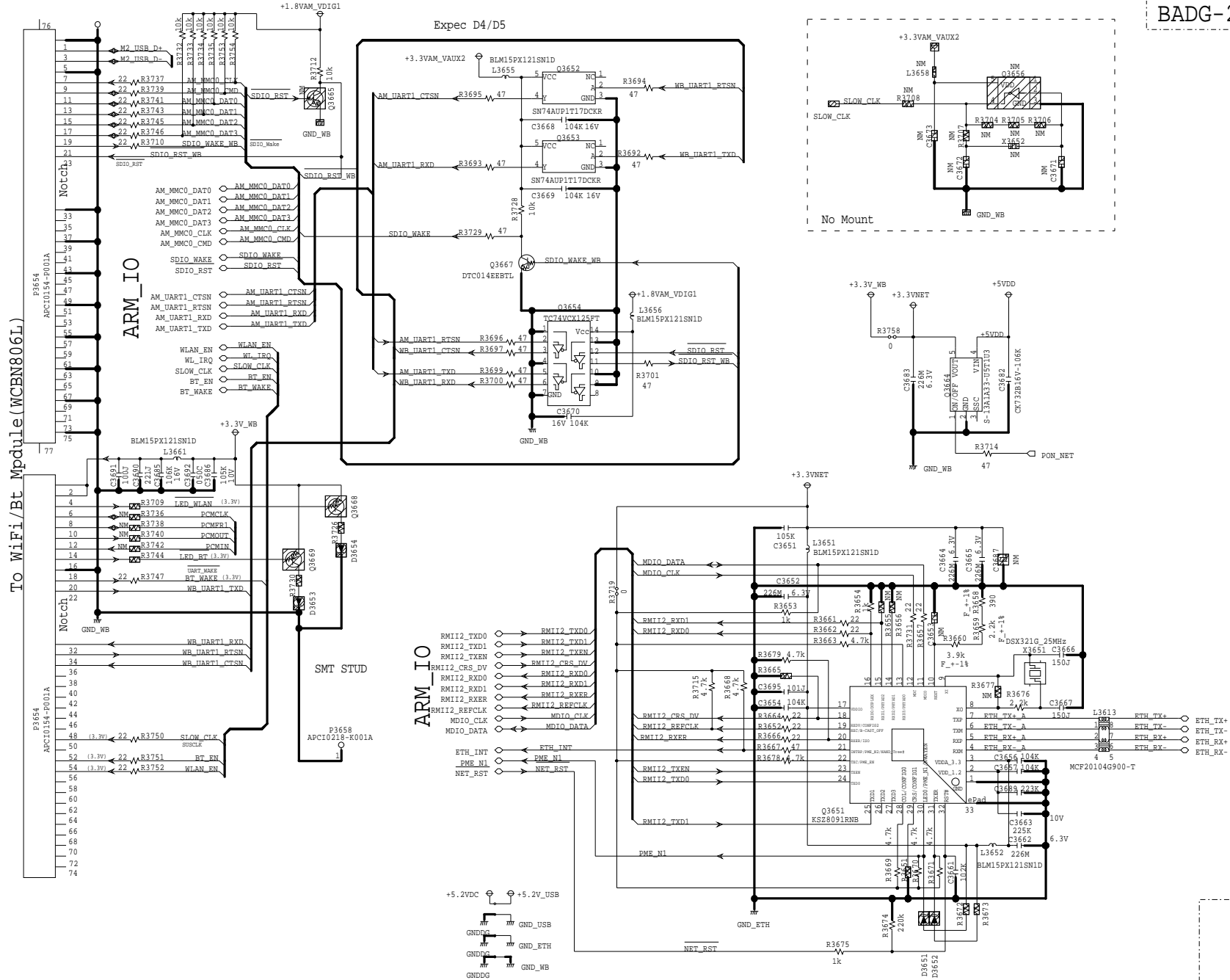

# PART-17 eMMC/HEADER CONNECTOR

# Schematic Diagram

BADG-2252 (5/5)

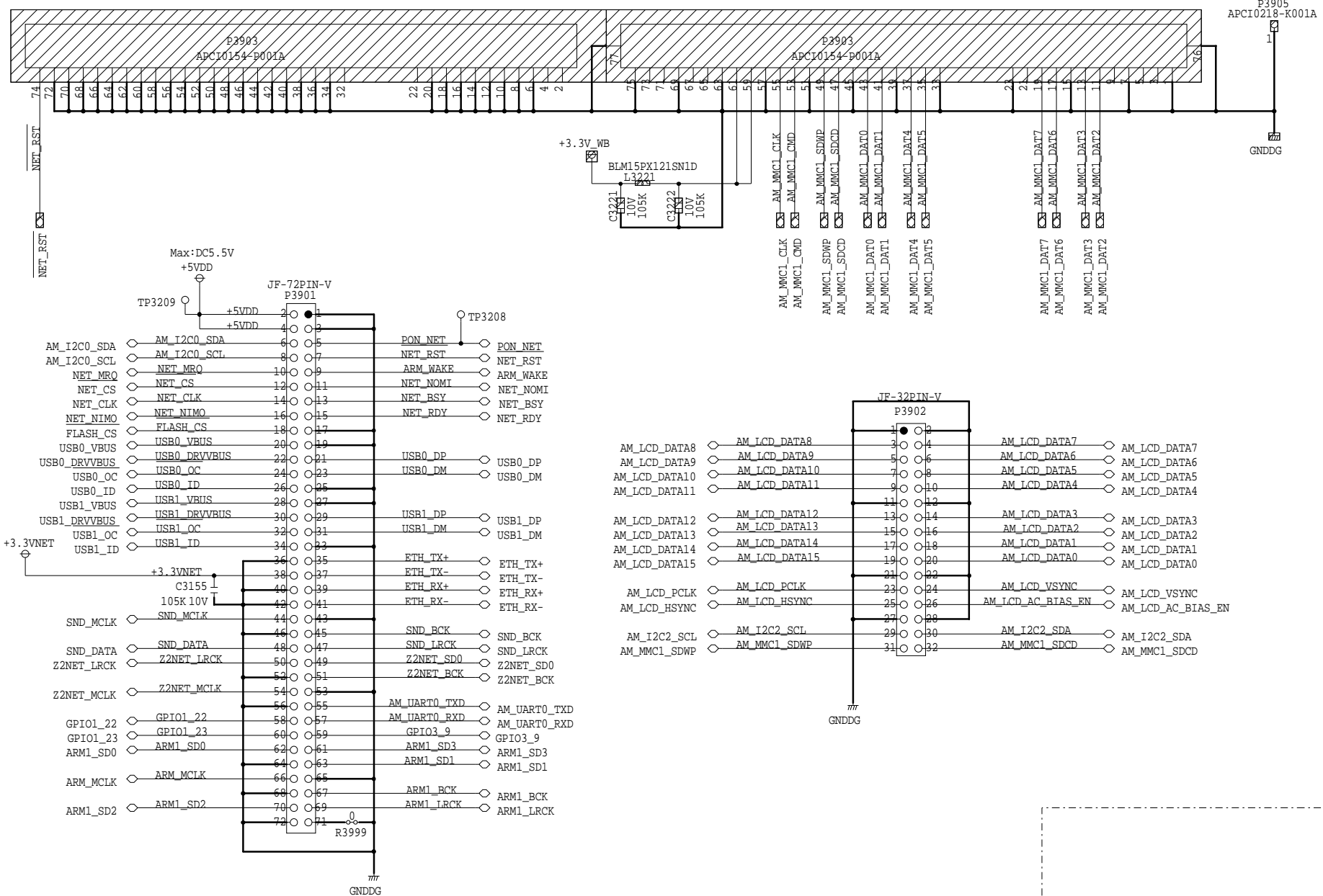

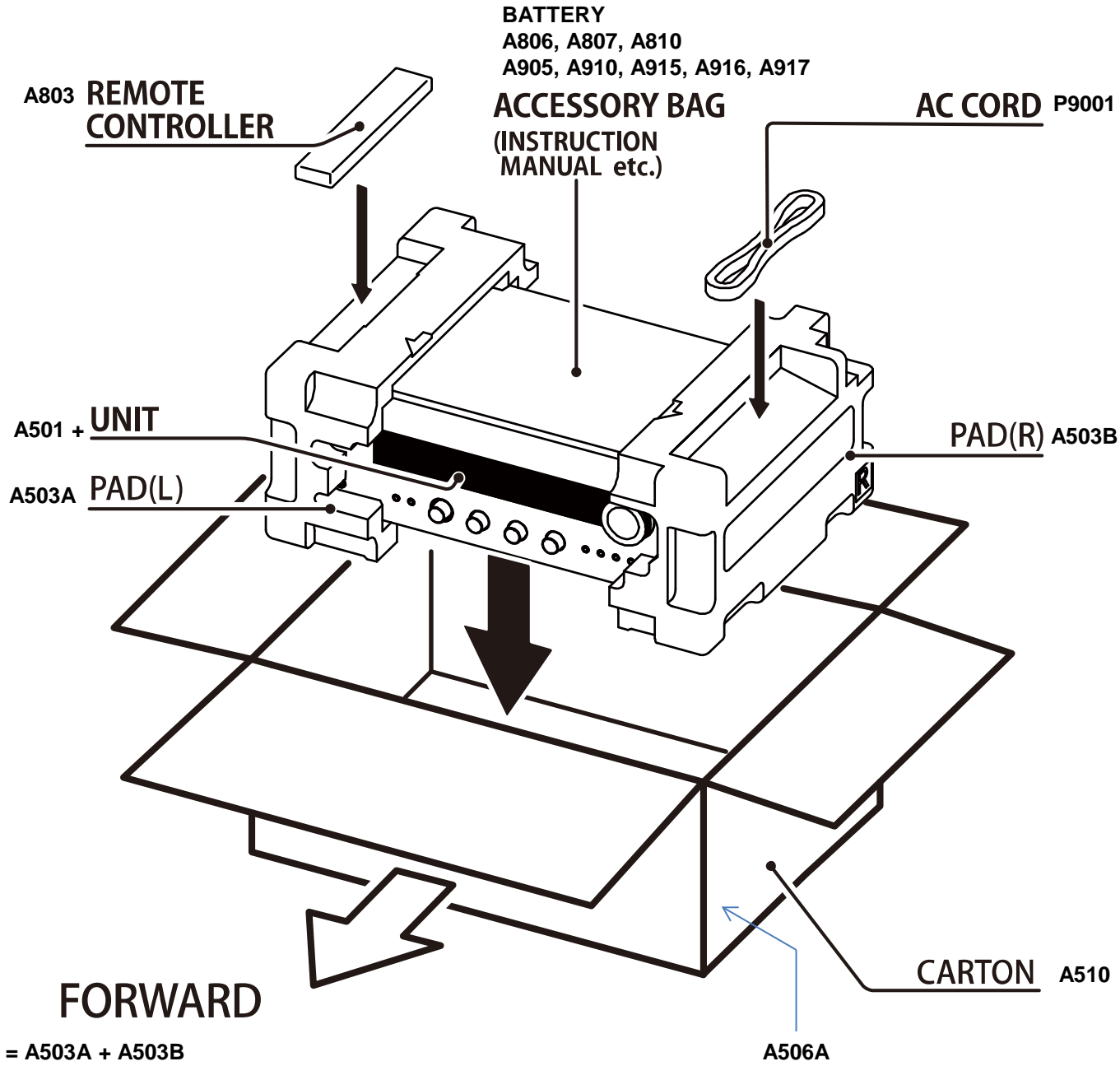

# Overview

# Exploded View

## P3654A: WiFi/Bluetooth Module

\* This module transmitter does not have RF shielding, therefore it will be equipped only the tested Audio system mentioning this document. Additional test will be required if it will be equipped to the other devices.

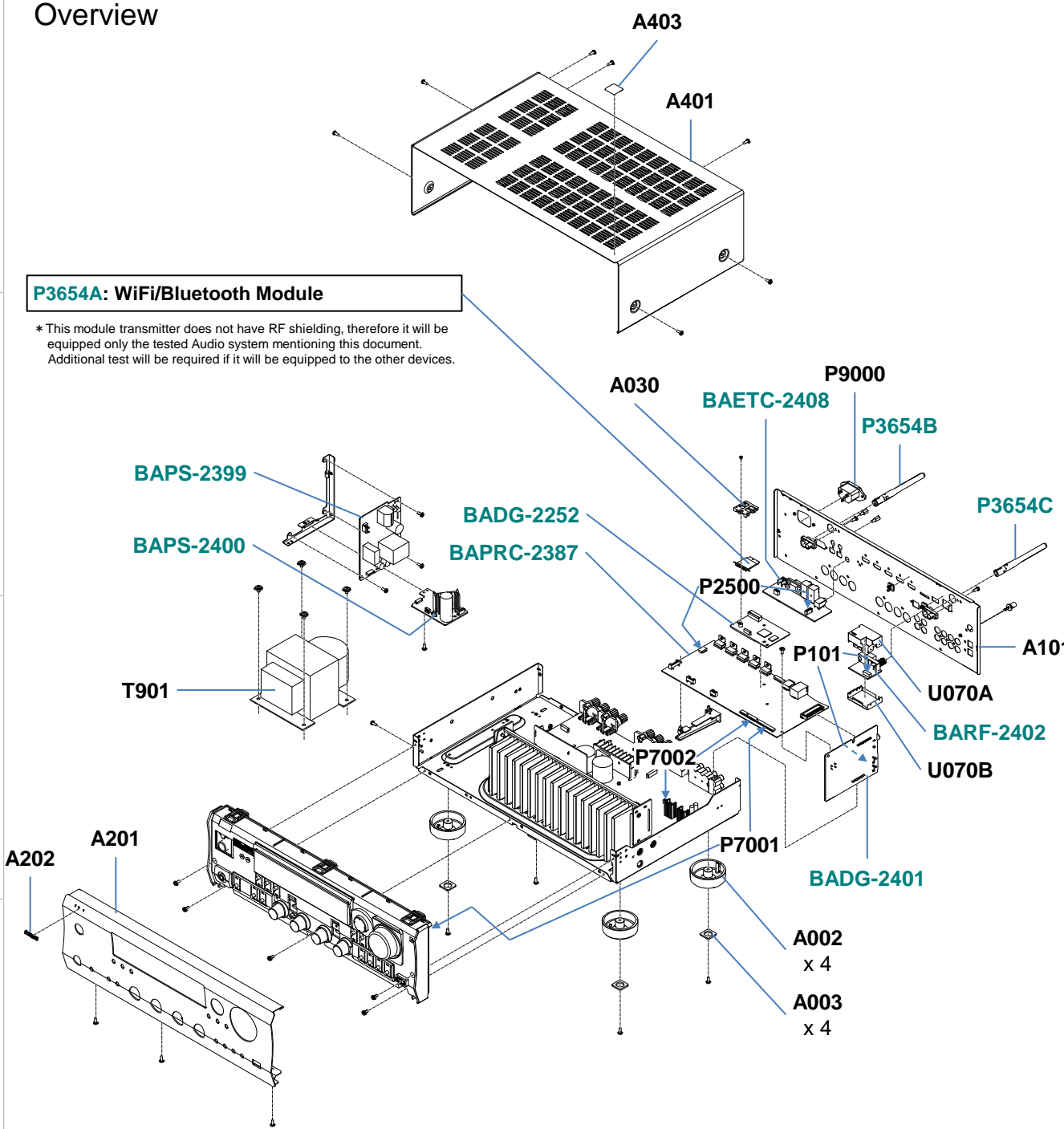

### \* WiFi & Bluetooth Module has already been certificated by FCC and IC.

Information to the user.  
Indicate "Contains FCC ID: TX2-RTL8821AE", "Contains IC: 6317A-RTL8821AE" and following information to the host device installed.

This device complies with part 15 of the FCC Rules. Operation is subject to the following two conditions: (1) This device may not cause harmful interference, and (2) this device must accept any interference received, including interference that may cause undesired operation.

Describe the following sentence to a user's manual of the host device.

[For FCC]  
FCC CAUTION

Changes or modifications not expressly approved by the party responsible for compliance could void the user's authority to operate the equipment.

Note: This equipment has been tested and found to comply with the limits for a Class B digital device, pursuant to part 15 of the FCC Rules. These limits are designed to provide reasonable protection against harmful interference in a residential installation. This equipment generates, uses and can radiate radio frequency energy and, if not installed and used in accordance with the instructions, may cause harmful interference to radio communications.

However, there is no guarantee that interference will not occur in a particular installation. If this equipment does cause harmful interference to radio or television reception, which can be determined by turning the equipment off and on, the user is encouraged to try to correct the interference by one or more of the following measures:

- Reorient or relocate the receiving antenna.
- Increase the separation between the equipment and receiver.
- Connect the equipment into an outlet on a circuit different from that to which the receiver is connected.
- Consult the dealer or an experienced radio/TV technician for help.

This transmitter must not be co-located or operated in conjunction with any other antenna or transmitter.

This equipment complies with FCC radiation exposure limits set forth for an uncontrolled environment and meets the FCC radio frequency (RF) Exposure Guidelines in Supplement C to OET65. This equipment has very low levels of RF energy that it deemed to comply without maximum permissive exposure evaluation (MPE). But it is desirable that it should be installed and operated keeping the radiator at least 20cm or more away from person's body (excluding extremities: hands, wrists, feet and ankles).

[For IC]  
CAN ICES-3 B/NMB-3 B

This device complies with Industry Canada licence-exempt RSS standard(s). Operation is subject to the following two conditions: (1) this device may not cause interference, and (2) this device must accept any interference, including interference that may cause undesired operation of the device.

Le présent appareil est conforme aux CNR d'Industrie Canada applicables aux appareils radio exempts d'licence. L'exploitation est autorisée aux deux conditions suivantes : (1) l'appareil ne doit pas produire de brouillage, et (2) l'utilisateur de l'appareil doit accepter tout brouillage radioélectrique subi, même si le brouillage est susceptible d'en compromettre le fonctionnement.

This equipment complies with IC radiation exposure limits set forth for an uncontrolled environment and meets RSS-102 of the IC radio frequency (RF) Exposure rules. This equipment has very low levels of RF energy that it deemed to comply without maximum permissive exposure evaluation (MPE). But it is desirable that it should be installed and operated keeping the radiator at least 20cm or more away from person's body (excluding extremities: hands, wrists, feet and ankles).

Cet équipement est conforme aux limites d'exposition aux rayonnements énoncées pour un environnement non contrôlé et respecte les règles d'exposition aux fréquences radioélectriques (RF) CNR-102 de l'IC. Cet équipement émet une énergie RF très faible qui est considérée conforme sans évaluation de l'exposition maximale autorisée. Cependant, cet équipement doit être installé et utilisé en gardant une distance de 20 cm ou plus entre le dispositif rayonnant et le corps (à l'exception des extrémités : mains, poignets, pieds et chevilles).

Front

# Exploded View

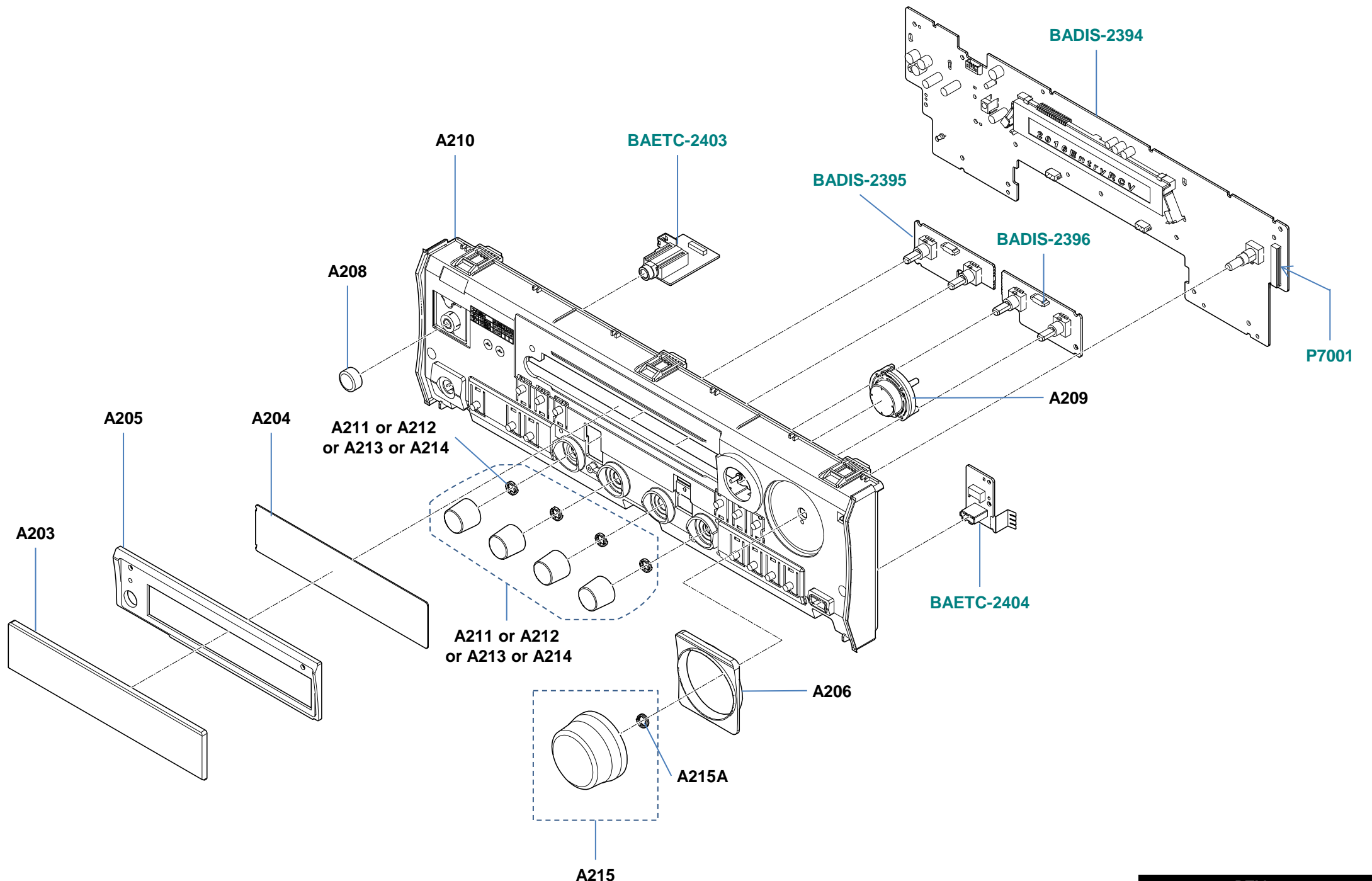

# Exploded View

Rear

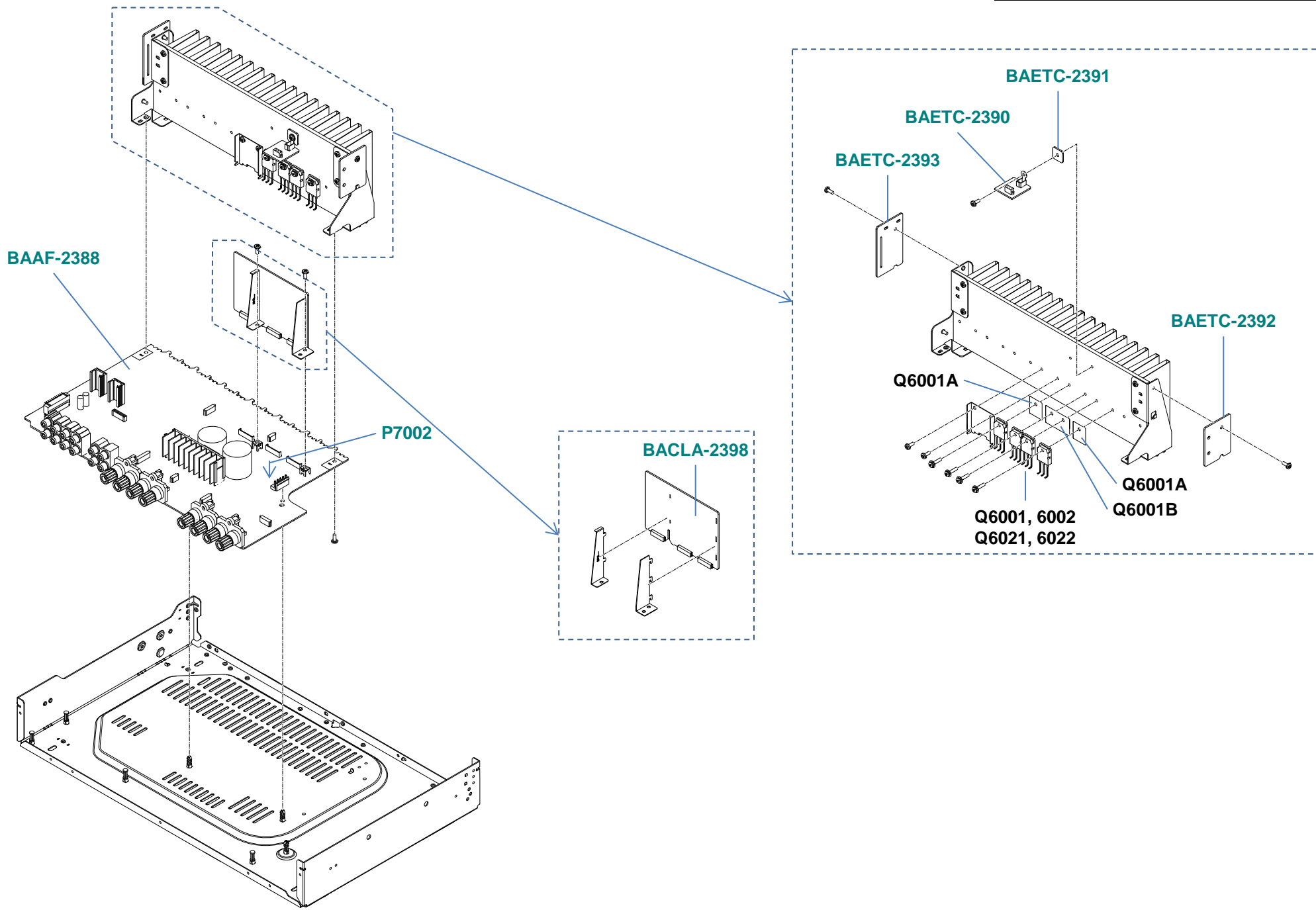

## Notation button operation

Use the following expressions to simplify the description of the button operation.

E.g.1)

[TV] + [ON/STANDBY] → [BD/DVD]

This means "While holding down TV button, press ON/STANDBY button then release both buttons and then press BD/DVD button".

E.g.2)

[DISPLAY] + [ON/STANDBY] x 2 → [DIMMER]

This means "While holding down DISPLAY button, press ON/STANDBY button twice then release both buttons and then press DIMMER button".



Do the following operation in the state of the volume initial value (40).

1. [ MEMORY ] + [ ON/STANDBY ] with Volume 40 → [ RETURN ] x 2

Unplug the power cord from AVR after the disappeared "All Clear" of FL tube and AVR goes standby.

MAIN checksum verification.

1. [ DIMMER ] + [ ON/STANDBY ] x 2 → [ ENTER ]

# Temperature sensor check

[ DIMMER ] + [ ON/STANDBY ] x 2 → [ TONE ]

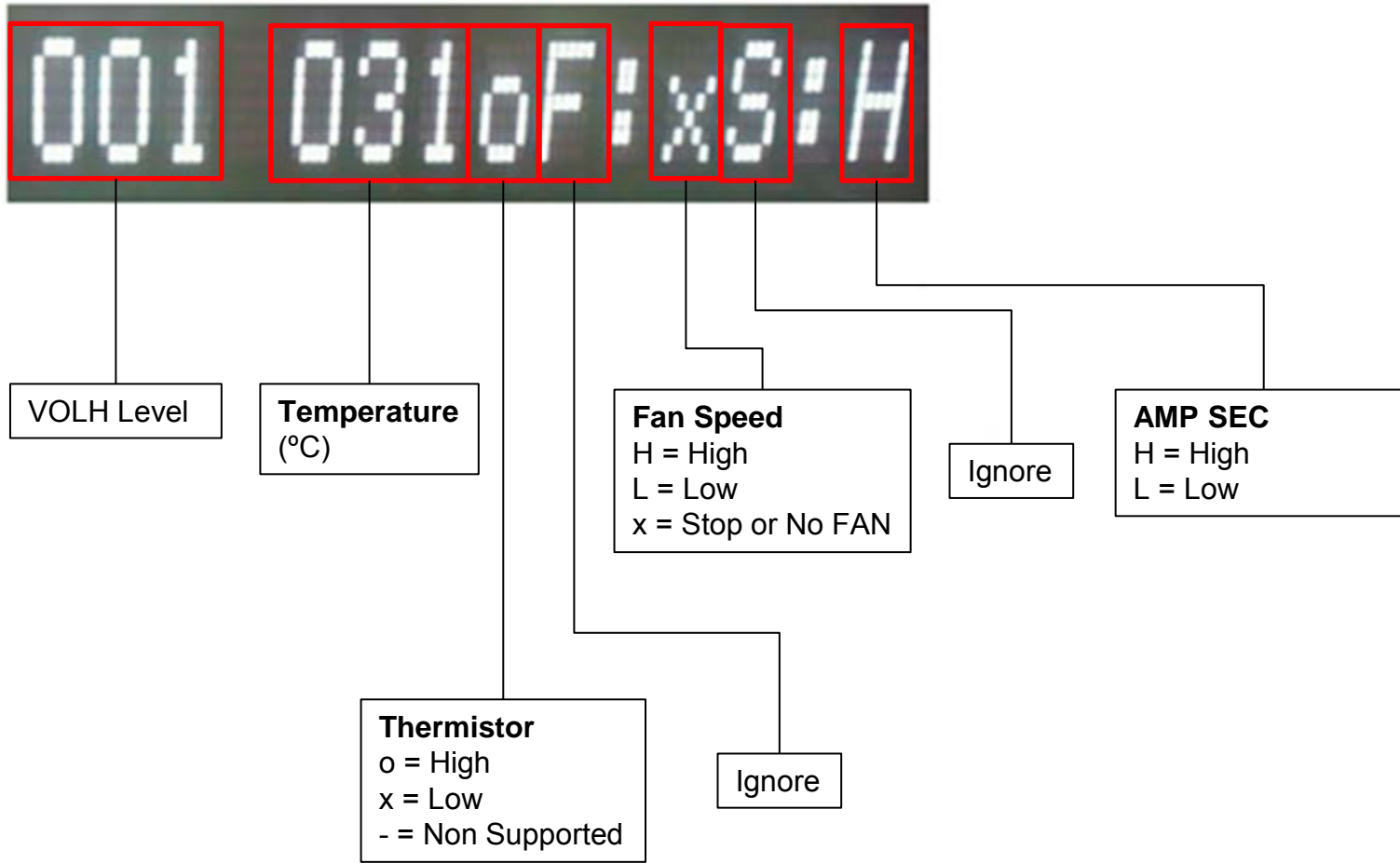

## Key operation check

1. Set Volume level 40.
2. [ TUNING UP ] + [ ON/STANDBY ]
3. [ INPUT ] → [ BASS ] turn right.
4. Shift to Key test mode.  
TEST Mode : TEST 1-06
5. Check each key and master volume operation.
6. If "ON/STANDBY" button is pressed, AVR escapes from this KEY test mode.  
Therefore, press the "ON/STANDBY" button, after checking other buttons finished.

Check the FL tube and LED.

1. [ Tune UP ] + [ ON/STANDBY ] → [ DIMMER ]

Check the FL tube.

1. Set Volume level 40.
2. [ TUNING UP ] + [ ON/STANDBY ] → [ DIMMER ]
3. Shift to FL tube test mode.

[ BASS ] turn right = Step up

[ BASS ] turn left = Step down

1. Lit all segment
2. Lit '23456789ABCDEF'
3. Lit a even number segment
4. Lit an odd number segment
5. The Destination setting is displayed.

**DTM-7(B)MDD****<Note>**

1. Parts marked by "NSP" are generally unavailable because they are not in our Master Spare Parts List.
  2. The ! mark found on some component parts indicates the importance of the safety factor of the part.
- Therefore, when replacing, be sure to use parts of identical designation.

**(B) : Black color model****<MDD> : 120V****USA model**

: NSP

REF. NO.	PART NAME	DESCRIPTION	Q'TY	PART NO. (SN)	REMARKS
<b>[ Cabinet, Chassis, Screws, Nuts ]</b>					
A001	CHASSIS	(2017entry)	1	27100627A	NSP
A002	LEG	(B)	4	27175464	
A003	CUSHION	(LEG)	4	28141735	N
A004	SCREW	3TTB+8B(3BC)	4	838430088GR	NSP
A005	HOLDER	(CPS-8)	2	27191383	NSP
A005or	HOLDER	KGLS-8RT	(2)	27190503A	NSP
A006	HOLDER	(NPS-14)	4	27191388	NSP
A006or	HOLDER	KGPS-14RF	(4)	27190802	NSP
A007	HOLDER	KGLS-10RT	1	27190428A	NSP
A007or	HOLDER	(CPS-10)	(1)	27191384	NSP
A008	HEAT SINK	(RAD-286)	1	27160718	NSP
A009	SCREW	3SMS8W.SW+14B(CU)	4	801634	NSP
A010	RETAINER	(HL-474)	1	27142370	NSP
A011	SCREW	3TTB+8B(3BC)	2	838430088GR	NSP
A012	RETAINER	(HR-474)	1	27142371	NSP
A013	SCREW	3TTB+8B(3BC)	2	838430088GR	NSP
A014	SCREW	3TTB+8B(3BC)	2	838430088GR	NSP
A015	RETAINER	(B)	1	27142141A	NSP
A016	SCREW	3TTB+8B(3BC)	2	838430088GR	NSP
A017	SCREW	3TTB+8B(3BC)	2	838430088GR	NSP
A018	SCREW	3TTB+8B(3CM)SR	2	801637	NSP
A019	RETAINER	(PS-474)	1	27142372A	NSP
A020	SCREW	3TTB+8B(3BC)	4	838430088GR	NSP
A021	SCREW	3TTB+8B(3CM)SR	1	801637	NSP
A022	SCREW	3TTB+8B(3BC)	1	838430088GR	NSP
A023	SCREW	3TTB+8B(3BC)	1	838430088GR	NSP
A024	SCREW	4TTC+8C(3BC)SR	4	801658	NSP
A025	HOLDER	(PRC)	1	27191419A	NSP
A026	HOLDER	(ANTENNA)(B)	2	27191426	NSP
A028A	LABEL	(E-CON)	1	29364978	
A030	HOLDER	(PLUG)	1	27191418A	
A031	SCREW	2B+4FN(3BC)	1	82542004	NSP
A032	RETAINER	(TR)	1	27142309	NSP
A033	SCREW	3TTB+8B(3BC)	2	838430088GR	NSP
A034	SCREW	3TTB+8B(3BC)	2	838430088GR	NSP
A035	SCREW	3TTB+8B(3BC)	1	838430088GR	NSP
A036	WIRE TIE	BSK-1	10	260208	NSP
A037	TAPE	TAPE(CLOTH-16U)	0.1	29110083	NSP
A038	TAPE	TAPE(CLOTH-8U)	0.025	29110082	NSP
A039	TAPE	TAPE(CLOTH-8U)	0.008	29110082	NSP
A101	REAR PANEL	DTM7MDD	1	27124888A	N
A102	SCREW	3TTB+8B(3BC)	25	838430088GR	NSP
A103	SCREW	3P+6FN(3BC)	5	82143006GR	NSP
A104	SCREW	3TTF+10B(3BC)	2	835430108GR	NSP

A106	CUSHION	.	2	28141799	NSP
A107	TAPE	TAPE(CLOTH-8U)	0.02	29110082	NSP
A109	TERMINAL	Eターミナル	1	25060151	NSP
A110	WASHER	W3*10F(3BC)	1	87643010GR	NSP
A114	HOLDER	(CLAMP)	2	27191396	NSP
A201	FRONT PANEL	(DTM-7MDD)	1	27213991A	N
A202	BADGE	.	1	28135278	
A203	CLEAR PLATE	DTM-7	1	28192511	
A204	BACK PLATE	.	1	28133430	
A205	GUIDE	(DIS)	1	27268313A	NSP
A206	GUIDE	(VOL)	1	27268314	NSP
A208	KNOB	(STANDBY)	1	28325756A	
A209	KNOB	(CUR)	1	28327077	
A210	FRONT BRACKET	DTM(B)	1	27111634B	
A211	KNOB	(INPUT)(B)(8030)	1	28326954C	N
A211A	SPRING	.	{1}	27180575	
A212	KNOB	(INPUT)(B)(8030)	1	28326954C	N
A212A	SPRING	.	{1}	27180575	
A213	KNOB	(INPUT)(B)(8030)	1	28326954C	N
A213A	SPRING	.	{1}	27180575	
A214	KNOB	(INPUT)(B)(8030)	1	28326954C	N
A214A	SPRING	.	{1}	27180575	
A215	KNOB	(VOL)AS	1	28326685C	
A215A	SPRING	.	{1}	27180575	
A215B	KNOB	(BASE)	{1}	28326684C	N NSP
A215C	KNOB	(CAP)	{1}	28326373A	NSP
A215D	CUSHION	15x20x20	{4}	28141807	NSP
A220	CUSHION	.	3	28141606	NSP
A230	SCREW	3TTB+8B(3BC)	16	838430088GR	NSP
A231	SCREW	3TTB+8B(3BC)	3	838430088GR	NSP
A232	SCREW	3TTB+8B(3BC)	5	838430088GR	NSP
A401	COVER	(B) (Bent)	1	28210031	
A401	COVER	(B) (Not Bent)	1	28210031Z	
A402	SCREW	3TTB+8B(3BC)	7	838430088GR	NSP
A403	LABEL	(CAUTION)	1	29392531	
A404	LABEL	(Hi-Res)11x11	1	29393649	N NSP
<b>[ Semi-conductors ]</b>					
Q6001	TRANSISTOR	2SD2560-O	1	2204363	
Q6001or	TRANSISTOR	2SD2560-P	(1)	2204361	
Q6001A	ISO SHEET	AC238	2	223024	
Q6001B	ISO SHEET	ISO SHEET	1	223050	
Q6002	TRANSISTOR	2SD2560-O	1	2204363	
Q6002or	TRANSISTOR	2SD2560-P	(1)	2204361	
Q6021	TRANSISTOR	2SB1647-O	1	2204353	
Q6021or	TRANSISTOR	2SB1647-P	(1)	2204351	
Q6022	TRANSISTOR	2SB1647-O	1	2204353	
Q6022or	TRANSISTOR	2SB1647-P	(1)	2204351	
<b>[ Transformers, Coils ]</b>					
T901	POWER TRANSFORMER	NPT-1687D	1	2302195	!
<b>[ Switches, Terminals, Wires ]</b>					
F6901	FUSE	6.3A-UL/T-233	1	252328GR	! BAAF-2388
F6901or	FUSE	6.3A-T/UL-ST2	(1)	252260GR	!
F6901E	FUSE LABEL	6.3A/125V	1	29362027	! BAAF-2388
F6902	FUSE	6.3A-UL/T-233	1	252328GR	! BAAF-2388
F6902or	FUSE	6.3A-T/UL-ST2	(1)	252260GR	!



F9002	FUSE	6.3A-UL/T-233	1	252328GR	!	BAPS-2399
F9002or	FUSE	6.3A-T/UL-ST2	(1)	252260GR	!	
F9002E	FUSE LABEL	6.3A/125V	1	29362027	!	BAPS-2399
P101	FLEXIBLE FLAT CABLE	NCFC7-071512	1	2047071512		
P2500	FLEXIBLE FLAT CABLE	NCFC5-090512	1	2045090512		
P3652	WIRE HARNESS ASSEMBLY	NSAS-10P1924	1	2009991224UL		NSP
P3654A	ASSEMBLED PWB	WCBN806L	1	24150135		
P3654B	WIFI BT ANTENNA	RFDP A870918EMLB302	1	2050102		
P3654C	WIFI BT ANTENNA	RFDP A870940EMLB303	1	2050103		
P7001	FLEXIBLE FLAT CABLE	NCFC5-312212	1	2045312212		
P7002	FLEXIBLE FLAT CABLE	NCFC5-151012	1	2045151012		
P9000	AC INLET	R301X2PSn	1	25053358	!	
P9000A	FASTON ASSEMBLY	FASTON SOCKET	1	1F999027		NSP
<b>[ Frontend, Units ]</b>						
<b>U040</b>	<b>PARENT PC BOARD AS</b>	<b>BADG-2252-2A-P</b>	<b>1</b>	<b>1B5142252-2A</b>		<b>Parent</b>
BADG-2252	Digital circuit pc board AS	BADG-2252-2A	1	1B5142252-2A-C		Child
<b>U030</b>	<b>PARENT PC BOARD AS</b>	<b>BAPRC-2387-1L-P</b>	<b>1</b>	<b>1B5142387-1L</b>		<b>Parent</b>
BAPRC-2387	Processing circuit pc board AS	BAPRC-2387-1L	1	1B5142387-1L-C		Child
<b>U020</b>	<b>PARENT PC BOARD AS</b>	<b>BAAF-2388-1N-P</b>	<b>1</b>	<b>1B5142388-1N</b>		<b>Parent</b>
BAAF-2388	Audio frequency circuit pc board AS	BAAF-2388-1N	1	1B5142388-1N-C		Child
BAETC-2390	Et cetra pc board AS	BAETC-2390-1N	1	1B5142390-1N-C		Child
BAETC-2391	Et cetra pc board AS	BAETC-2391-1N	1	1B5142391-1N-C		Child
BAETC-2392	Et cetra pc board AS	BAETC-2392-1N	1	1B5142392-1N-C		Child
BAETC-2393	Et cetra pc board AS	BAETC-2393-1N	1	1B5142393-1N-C		Child
<b>U070</b>	<b>PARENT PC BOARD AS</b>	<b>BADIS-2394-1C-P</b>	<b>1</b>	<b>1B5142394-1C</b>		<b>Parent</b>
BADIS-2394	Display circuit pc board AS	BADIS-2394-1C	1	1B5142394-1C-C		Child
BASW-2395	Switch circuit pc board AS	BASW-2395-1C	1	1B5142395-1C-C		Child
BASW-2396	Switch circuit pc board AS	BASW-2396-1C	1	1B5142396-1C-C		Child
BACLA-2398	ClassA amplifier circuit pc board AS	BACLA-2398-1C	1	1B5142398-1C-C		Child
BAPS-2399	Power supply circuit pc board AS	BAPS-2399-1C	1	1B5142399-1C-C		Child
BAPS-2400	Power supply circuit pc board AS	BAPS-2400-1C	1	1B5142400-1C-C		Child
BADG-2401	Digital circuit pc board AS	BADG-2401-1C	1	1B5142401-1C-C		Child
BARF-2402	Radio frequency circuit pc board AS	BARF-2402-1C	1	1B5142402-1C-C		Child
BAETC-2403	Et cetra pc board AS	BAETC-2403-1C	1	1B5142403-1C-C		Child
BAETC-2404	Et cetra pc board AS	BAETC-2404-1C	1	1B5142404-1C-C		Child
BAETC-2408	Et cetra pc board AS	BAETC-2408-1C	1	1B5142408-1C-C		Child
U070A	SHIELD CASE	(UPPER)	1	27225208		
U070B	SHIELD CASE	(TUNER-BTM)	1	27225207A		
<b>[ Packing ]</b>						
A501	SHEET	T0.515x1300x650	1	29096184		
A502	TAPE	(SEROHAN)NITTO NO.29	0.2	29110149		NSP
A503	PAD	(AS)8270	1	29092808A		
A503A	PAD	(L)8270	{1}	29092809		N
A503B	PAD	(R)8270	{1}	29092810A		N
A506A	UPC LABEL	(DTM-7(B)MDD)	1	29393540		N
A510	CARTON	DTM-7(B)MDD	1	29055776A		N
A511	POLYPROPYLENE TAPE	W50 SBT-70	2	29110200		NSP
<b>[ Accessories ]</b>						
P9001	POWER SUPPLY CORD	AS-UC-2	1	253352ATES	!	
A801	POLY BAG	(W250xD350)LDPE	1	29100272		NSP
A802	TAPE	(SEROHAN)NITTO NO.29	0.2	29110149		NSP
A803	REMOTE CONTROL TRANSMITTER	RC-906S	1	24140906		
A804	BATTERY	R03/AAA(UM-4)	2	3010124		NSP
A806	ANTENNA COIL	AM LOOP ANTENNA (S&O)	1	232216		
A806or	ANTENNA COIL	AM LOOP-ANTENNA	(1)	232207		

A807	FM ANT AS	Type W	1	292191	
A810	WARRANTY CARD	(INTEGRA)	1	29365157A	
A905	INSTRUCTION MANUAL	QSG_En(DTM-7)	1	29402836	N
A910	INSTRUCTION MANUAL	SAFETY_INT_En(2017)	1	29402755	N
A915	INSTRUCTION SHEET	(FWupdate-Fireconnect)	1	29355967	
A916	INSTRUCTION SHEET	(Chromecast built-in)	1	29355977	N
A917	INSTRUCTION SHEET	(DTS PlayFi)	1	29355978	N

**BAAF-2388-1N****<Note>**

1. Parts marked by "NSP" are generally unavailable because they are not in our Master Spare Parts List.
2. The ! mark found on some component parts indicates the importance of the safety factor of the part.  
Therefore, when replacing, be sure to use parts of identical designation.

: NSP

REF. NO.	PART NAME	DESCRIPTION	Q'TY	PART NO. (SN)	REMARKS
<b>[ Semi-conductors ]</b>					
D4251	DIODE	RL1N4003	1	22380260T	NSP
D4252	DIODE	RL1N4003	1	22380260T	NSP
D4253	DIODE	RL1N4003	1	22380260T	NSP
D4254	DIODE	RL1N4003	1	22380260T	NSP
D4259	ZENER DIODE	DZ2J068M0L	1	224760680R2	NSP
D4260	ZENER DIODE	DZ2J068M0L	1	224760680R2	NSP
D6501	CHIP TYPE DIODE	DA2J10100	1	223303R2	NSP
D6501or	CHIP TYPE DIODE	1SS352	(1)	223234R2	NSP
D6505	CHIP TYPE DIODE	DA2J10100	1	223303R2	NSP
D6505or	CHIP TYPE DIODE	1SS352	(1)	223234R2	NSP
D6601	CHIP TYPE DIODE	DA2J10100	1	223303R2	NSP
D6601or	CHIP TYPE DIODE	1SS352	(1)	223234R2	NSP
D6602	CHIP TYPE DIODE	DA2J10100	1	223303R2	NSP
D6602or	CHIP TYPE DIODE	1SS352	(1)	223234R2	NSP
D6621	CHIP TYPE DIODE	DA2J10100	1	223303R2	NSP
D6621or	CHIP TYPE DIODE	1SS352	(1)	223234R2	NSP
D6622	CHIP TYPE DIODE	DA2J10100	1	223303R2	NSP
D6622or	CHIP TYPE DIODE	1SS352	(1)	223234R2	NSP
D6703	ZENER DIODE	DZ2J036M0L	1	224760360R2	NSP
D6704	CHIP TYPE DIODE	DA2J10100	1	223303R2	NSP
D6705	CHIP TYPE DIODE	DA2J10100	1	223303R2	NSP
D6707	ZENER DIODE	DZ2J100M0L	1	224761000R2	NSP
D6740	CHIP TYPE DIODE	DA2J10100	1	223303R2	NSP
D6741	CHIP TYPE DIODE	DA2J10100	1	223303R2	NSP
D6761	CHIP TYPE DIODE	DA2J10100	1	223303R2	NSP
D6762	CHIP TYPE DIODE	DA2J10100	1	223303R2	NSP
D6780	ZENER DIODE	DZ2J033M0L	1	224760330R2	NSP
D6901	DIODE	TS10B06G-07	1	22380379	
D6901A	HEAT SINK	RAD-196	1	27160545	NSP
D6901B	SCREW	3P+10FN(3BC)	1	82143010GR	NSP
D6911	CHIP TYPE DIODE	DA2J10100	1	223303R2	NSP
Q4001	HYBRID IC	BD34704KS2	1	22242977R3	
Q4004	HYBRID IC	NJM4580CG	1	22242922R2	NSP

Q4008	HYBRID IC	NJM4580CG	1	22242922R2	NSP
Q4101	TRANSISTOR	RTAN430C-T112-1	1	2217780R2	NSP
Q4102	TRANSISTOR	RTAN430C-T112-1	1	2217780R2	NSP
Q4104	TRANSISTOR	RTAN430C-T112-1	1	2217780R2	NSP
Q4114	TRANSISTOR	RTAN430C-T112-1	1	2217780R2	NSP
Q4251	HYBRID IC	78M15HF(NJM78M15FA)	1	222780155JRC	
Q4251A	HEAT SINK	ME151025402170	1	27160692	NSP
Q4251B	SCREW	3P+10FN(3BC)	1	82143010GR	NSP
Q4252	HYBRID IC	79M15HF(NJM79M15FA)	1	222790155JRC	
Q4252A	HEAT SINK	ME151025402170	1	27160692	NSP
Q4252B	SCREW	3P+10FN(3BC)	1	82143010GR	NSP
Q4301	TRANSISTOR	RTAN430C-T112-1	1	2217780R2	NSP
Q4302	TRANSISTOR	RTAN430C-T112-1	1	2217780R2	NSP
Q4530	HYBRID IC	NJM4580CG	1	22242922R2	NSP
Q5621	TRANSISTOR	2SD2704K	1	2218130R2	
Q5622	TRANSISTOR	2SD2704K	1	2218130R2	
Q6501	TRANSISTOR	KRC105S	1	2217290R2	NSP
Q6501or	TRANSISTOR	DTC123JCAT116	(1)	2219040R2	NSP
Q6503	TRANSISTOR	KRC105S	1	2217290R2	NSP
Q6503or	TRANSISTOR	DTC123JCAT116	(1)	2219040R2	NSP
Q6601	TRANSISTOR	INC6002AC1	1	2218840R2	NSP
Q6602	TRANSISTOR	INC6002AC1	1	2218840R2	NSP
Q6700	TRANSISTOR	2SA1163-BL	1	2216756R2	NSP
Q6705	TRANSISTOR	2SC2713-BL	1	2213136R2	NSP
Q6706	TRANSISTOR	KRA102S	1	2216220R2	NSP
Q6706or	TRANSISTOR	DTA114ECAT116	(1)	2218980R2	NSP
Q6740	TRANSISTOR	2SC2713-BL	1	2213136R2	NSP
Q6741	TRANSISTOR	2SC2713-BL	1	2213136R2	NSP
Q6742	TRANSISTOR	2SA1163-BL	1	2216756R2	NSP
Q6800	HYBRID IC	LM61CIZ	1	22242212	
Q6800A	RETAINER	(PTH)	1	27141884-1	NSP
Q6801	TRANSISTOR	2SC2712-GR	1	2213145R2	NSP
Q6802	TRANSISTOR	2SA1162-GR	1	2214375R2	NSP
Q6911	TRANSISTOR	KRC105S	1	2217290R2	NSP
Q6911or	TRANSISTOR	DTC123JCAT116	(1)	2219040R2	NSP
<b>[ Capacitors ]</b>					
C4007	CHIP TYPE CERAMIC CAPACITOR	CC725CH1H-221J1	1	342102214R1	NSP
C4008	CHIP TYPE CERAMIC CAPACITOR	CC725CH1H-221J1	1	342102214R1	NSP
C4009	UPZ TYPE PLASTIC FILM CAPACITOR	2AUPZTF221JE	1	376332214T	NSP
C4010	UPZ TYPE PLASTIC FILM CAPACITOR	2AUPZTF221JE	1	376332214T	NSP
C4011	CHIP TYPE CERAMIC CAPACITOR	CC725CH1H-221J1	1	342102214R1	NSP
C4012	CHIP TYPE CERAMIC CAPACITOR	CC725CH1H-221J1	1	342102214R1	NSP
C4015	CHIP TYPE CERAMIC CAPACITOR	CC725CH1H-221J1	1	342102214R1	NSP
C4016	CHIP TYPE CERAMIC CAPACITOR	CC725CH1H-221J1	1	342102214R1	NSP
C4053	CHIP TYPE CERAMIC CAPACITOR	CK725B1H-102K1	1	332101025R1	NSP
C4054	CHIP TYPE CERAMIC CAPACITOR	CK725B1H-102K1	1	332101025R1	NSP
C4061	CHIP TYPE CERAMIC CAPACITOR	CC725CH1H-101J1	1	342101014R1	NSP
C4062	CHIP TYPE CERAMIC CAPACITOR	CC725CH1H-101J1	1	342101014R1	NSP
C4063	UTSP TYPE ELECTROLYTIC CAPACITOR	CE04W25V-47M(UTSP)	1	397554707AT	
C4064	UTSP TYPE ELECTROLYTIC CAPACITOR	CE04W25V-47M(UTSP)	1	397554707AT	
C4101	UTSP TYPE ELECTROLYTIC CAPACITOR	CE04W50V 47M(UTSP)	1	397584707AT	
C4102	UTSP TYPE ELECTROLYTIC CAPACITOR	CE04W50V 47M(UTSP)	1	397584707AT	
C4104	UTSP TYPE ELECTROLYTIC CAPACITOR	CE04W50V-22M(UTSP)	1	397582207AT	
C4114	CHIP TYPE CERAMIC CAPACITOR	CC725CH1H-221J1	1	342102214R1	NSP
C4175	JAMICON TYPE ELECTROLYTIC CAPACITC	CE04W16V-220M	1	398542217T	

C4176	JAMICON TYPE ELECTROLYTIC CAPACIT	CE04W16V-220M	1	398542217T	
C4181	FILM C	C281H104J20A21A	1	376821044T	NSP
C4190	UTSP TYPE ELECTROLYTIC CAPACITOR	CE04W50V 47M(UTSP)	1	397584707AT	
C4191	CHIP TYPE CERAMIC CAPACITOR	CC725CH1H-221J1	1	342102214R1	NSP
C4192	CHIP TYPE CERAMIC CAPACITOR	CK725B1H-103K1	1	332101035R1	NSP
C4206	CHIP TYPE CERAMIC CAPACITOR	CK725B1H-102K1	1	332101025R1	NSP
C4207	CHIP TYPE CERAMIC CAPACITOR	CK725B1H-102K1	1	332101025R1	NSP
C4250	FILM C	C282A334J20A21A	1	376833344T	NSP
C4251	JAMICON TYPE ELECTROLYTIC CAPACIT	CE04W35V-1000M	1	398561027T	
C4252	JAMICON TYPE ELECTROLYTIC CAPACIT	CE04W35V-1000M	1	398561027T	
C4253	FILM C	C281H104J20A21A	1	376821044T	NSP
C4254	FILM C	C281H104J20A21A	1	376821044T	NSP
C4255	JAMICON TYPE ELECTROLYTIC CAPACIT	CE04W50V-10M	1	398581007T	
C4255or	UTSP TYPE ELECTROLYTIC CAPACITOR	CE04W50V-10M(UTSP)	(1)	397581007AT	
C4256	JAMICON TYPE ELECTROLYTIC CAPACIT	CE04W50V-10M	1	398581007T	
C4256or	UTSP TYPE ELECTROLYTIC CAPACITOR	CE04W50V-10M(UTSP)	(1)	397581007AT	
C4261	JAMICON TYPE ELECTROLYTIC CAPACIT	CE04W16V-470M	1	398544717T	
C4261or	UTSP TYPE ELECTROLYTIC CAPACITOR	CE04W16V-470M(UTSP)	(1)	397544717T	
C4262	JAMICON TYPE ELECTROLYTIC CAPACIT	CE04W16V-470M	1	398544717T	
C4262or	UTSP TYPE ELECTROLYTIC CAPACITOR	CE04W16V-470M(UTSP)	(1)	397544717T	
C4311	UTSP TYPE ELECTROLYTIC CAPACITOR	CE04W25V-47M(UTSP)	1	397554707AT	
C4312	UTSP TYPE ELECTROLYTIC CAPACITOR	CE04W25V-47M(UTSP)	1	397554707AT	
C4313	CHIP TYPE CERAMIC CAPACITOR	CC725CH1H-221J1	1	342102214R1	NSP
C4314	CHIP TYPE CERAMIC CAPACITOR	CC725CH1H-221J1	1	342102214R1	NSP
C4531	UTSP TYPE ELECTROLYTIC CAPACITOR	CE04W25V-47M(UTSP)	1	397554707AT	
C4532	UTSP TYPE ELECTROLYTIC CAPACITOR	CE04W25V-47M(UTSP)	1	397554707AT	
C4533	CHIP TYPE CERAMIC CAPACITOR	CC725CH1H-102J1	1	342101024R1	NSP
C4534	CHIP TYPE CERAMIC CAPACITOR	CC725CH1H-102J1	1	342101024R1	NSP
C4535	UMXR TYPE PLASTIC FILM CAPACITOR	1JUMXRTF123JE	1	376591234T	NSP
C4536	UMXR TYPE PLASTIC FILM CAPACITOR	1JUMXRTF123JE	1	376591234T	NSP
C4537	UMXR TYPE PLASTIC FILM CAPACITOR	1JUMXRTF332JE	1	376593324T	NSP
C4538	UMXR TYPE PLASTIC FILM CAPACITOR	1JUMXRTF332JE	1	376593324T	NSP
C4543	CHIP TYPE CERAMIC CAPACITOR	CK725B1H-472K1	1	332104725R1	NSP
C4544	CHIP TYPE CERAMIC CAPACITOR	CK725B1H-472K1	1	332104725R1	NSP
C4545	UTSP TYPE ELECTROLYTIC CAPACITOR	CE04W50V-10M(UTSP)	1	397581007AT	
C4546	UTSP TYPE ELECTROLYTIC CAPACITOR	CE04W50V-10M(UTSP)	1	397581007AT	
C4547	JAMICON TYPE ELECTROLYTIC CAPACIT	CE04W16V-220M	1	398542217T	
C4548	JAMICON TYPE ELECTROLYTIC CAPACIT	CE04W16V-220M	1	398542217T	
C4549	CHIP TYPE CERAMIC CAPACITOR	CK725F1H-104Z1	1	332151040R1	NSP
C4550	CHIP TYPE CERAMIC CAPACITOR	CK725F1H-104Z1	1	332151040R1	NSP
C4551	UTSP TYPE ELECTROLYTIC CAPACITOR	CE04W10V-220M(UTSP)	1	397532217AT	
C4552	UTSP TYPE ELECTROLYTIC CAPACITOR	CE04W10V-220M(UTSP)	1	397532217AT	
C6461	UMXR TYPE PLASTIC FILM CAPACITOR	1JUMXRTF473JE	1	376594734T	NSP
C6462	UMXR TYPE PLASTIC FILM CAPACITOR	1JUMXRTF473JE	1	376594734T	NSP
C6501	CHIP TYPE CERAMIC CAPACITOR	CK725F1H-104Z1	1	332151040R1	NSP
C6505	CHIP TYPE CERAMIC CAPACITOR	CK725F1H-104Z1	1	332151040R1	NSP
C6521	UMXR TYPE PLASTIC FILM CAPACITOR	1JUMXRTF102JE	1	376591024T	NSP
C6522	UMXR TYPE PLASTIC FILM CAPACITOR	1JUMXRTF102JE	1	376591024T	NSP
C6525	UMXR TYPE PLASTIC FILM CAPACITOR	1JUMXRTF102JE	1	376591024T	NSP
C6526	UMXR TYPE PLASTIC FILM CAPACITOR	1JUMXRTF102JE	1	376591024T	NSP
C6601	FILM C	C281H474J20A21A	1	376824744T	NSP
C6602	FILM C	C281H474J20A21A	1	376824744T	NSP
C6700	UMXR TYPE PLASTIC FILM CAPACITOR	1JUMXRTF103JE	1	376591034T	NSP
C6703	CHIP TYPE CERAMIC CAPACITOR	CC725CH1H-101J1	1	342101014R1	NSP
C6704	CHIP TYPE CERAMIC CAPACITOR	CK725F1A-105Z1	1	332181050R1	NSP

C6705	CHIP TYPE CERAMIC CAPACITOR	CK725B1H-222K1	1	332102225R1	NSP
C6741	JAMICON TYPE ELECTROLYTIC CAPACIT	CE04W25V-220M	1	398552217T	
C6741or	UTSP TYPE ELECTROLYTIC CAPACITOR	CE04W25V-220M(UTSP)	(1)	397552217T	
C6742	CHIP TYPE CERAMIC CAPACITOR	CK725F1E-104Z1	1	332161040R1	NSP
C6744	JAMICON TYPE ELECTROLYTIC CAPACIT	CE04W50V-1M	1	398580107T	
C6744or	UTSP TYPE ELECTROLYTIC CAPACITOR	CE04W50V-1M(UTSP)	(1)	397580107AT	
C6780	JAMICON TYPE ELECTROLYTIC CAPACIT	CE04W50V-10M	1	398581007T	
C6780or	UTSP TYPE ELECTROLYTIC CAPACITOR	CE04W50V-10M(UTSP)	(1)	397581007AT	
C6800	CHIP TYPE CERAMIC CAPACITOR	CK725F1E-104Z1	1	332161040R1	NSP
C6801	CHIP TYPE CERAMIC CAPACITOR	CK725F1E-104Z1	1	332161040R1	NSP
C6901	ELECTROLYTIC CAPACITOR	CE69W69V-8200MMC	1	3504546	
C6901or	ELECTROLYTIC CAPACITOR	CE69W69V-8200MMN	(1)	3504525A	
C6902	ELECTROLYTIC CAPACITOR	CE69W69V-8200MMC	1	3504546	
C6902or	ELECTROLYTIC CAPACITOR	CE69W69V-8200MMN	(1)	3504525A	
C6903	FILM C	C282A334J20A21A	1	376833344T	NSP
C6904	FILM C	C282A334J20A21A	1	376833344T	NSP
C6911	CHIP TYPE CERAMIC CAPACITOR	CK725F1H-104Z1	1	332151040R1	NSP
<b>[ Resistors ]</b>					
R4001	CHIP TYPE CARBON RESISTOR	RN72K1J-000JE	1	435030004R1	NSP
R4002	CHIP TYPE CARBON RESISTOR	RN72K1J-000JE	1	435030004R1	NSP
R4003	CHIP TYPE CARBON RESISTOR	RN72K1J-000JE	1	435030004R1	NSP
R4005	CHIP TYPE CARBON RESISTOR	RN72K1J-000JE	1	435030004R1	NSP
R4006	CHIP TYPE CARBON RESISTOR	RN72K1J-000JE	1	435030004R1	NSP
R4007	CHIP TYPE CARBON RESISTOR	RN72K1J-000JE	1	435030004R1	NSP
R4009	CHIP TYPE CARBON RESISTOR	RN72K1J-000JE	1	435030004R1	NSP
R4012	CHIP TYPE CARBON RESISTOR	RN72K1J-000JE	1	435030004R1	NSP
R4013	CHIP TYPE CARBON RESISTOR	RN72K1J-331JE	1	435033314R1	NSP
R4014	CHIP TYPE CARBON RESISTOR	RN72K1J-331JE	1	435033314R1	NSP
R4015	CHIP TYPE CARBON RESISTOR	RN72K1J-104JE	1	435031044R1	NSP
R4016	CHIP TYPE CARBON RESISTOR	RN72K1J-104JE	1	435031044R1	NSP
R4017	CHIP TYPE CARBON RESISTOR	RN72K1J-331JE	1	435033314R1	NSP
R4018	CHIP TYPE CARBON RESISTOR	RN72K1J-331JE	1	435033314R1	NSP
R4019	CHIP TYPE CARBON RESISTOR	RN72K1J-104JE	1	435031044R1	NSP
R4020	CHIP TYPE CARBON RESISTOR	RN72K1J-104JE	1	435031044R1	NSP
R4021	CHIP TYPE CARBON RESISTOR	RN72K1J-331JE	1	435033314R1	NSP
R4022	CHIP TYPE CARBON RESISTOR	RN72K1J-331JE	1	435033314R1	NSP
R4023	CHIP TYPE CARBON RESISTOR	RN72K1J-104JE	1	435031044R1	NSP
R4024	CHIP TYPE CARBON RESISTOR	RN72K1J-104JE	1	435031044R1	NSP
R4029	CHIP TYPE CARBON RESISTOR	RN72K1J-331JE	1	435033314R1	NSP
R4030	CHIP TYPE CARBON RESISTOR	RN72K1J-331JE	1	435033314R1	NSP
R4031	CHIP TYPE CARBON RESISTOR	RN72K1J-563JE	1	435035634R1	NSP
R4032	CHIP TYPE CARBON RESISTOR	RN72K1J-563JE	1	435035634R1	NSP
R4033	CHIP TYPE CARBON RESISTOR	RN72K1J-104JE	1	435031044R1	NSP
R4034	CHIP TYPE CARBON RESISTOR	RN72K1J-104JE	1	435031044R1	NSP
R4051	CHIP TYPE CARBON RESISTOR	RN72K1J-000JE	1	435030004R1	NSP
R4052	CHIP TYPE CARBON RESISTOR	RN72K1J-000JE	1	435030004R1	NSP
R4053	CHIP TYPE CARBON RESISTOR	RN72K1J-102JE	1	435031024R1	NSP
R4054	CHIP TYPE CARBON RESISTOR	RN72K1J-102JE	1	435031024R1	NSP
R4055	CHIP TYPE CARBON RESISTOR	RN72K1J-224JE	1	435032244R1	NSP
R4056	CHIP TYPE CARBON RESISTOR	RN72K1J-224JE	1	435032244R1	NSP
R4057	CHIP TYPE CARBON RESISTOR	RN72K1J-104JE	1	435031044R1	NSP
R4061	CHIP TYPE CARBON RESISTOR	RN72K1J-223JE	1	435032234R1	NSP
R4062	CHIP TYPE CARBON RESISTOR	RN72K1J-223JE	1	435032234R1	NSP
R4063	CHIP TYPE CARBON RESISTOR	RN72K1J-331JE	1	435033314R1	NSP
R4064	CHIP TYPE CARBON RESISTOR	RN72K1J-331JE	1	435033314R1	NSP

R4065	CHIP TYPE CARBON RESISTOR	RN72K1J-332JE	1	435033324R1	NSP
R4066	CHIP TYPE CARBON RESISTOR	RN72K1J-332JE	1	435033324R1	NSP
R4067	CHIP TYPE CARBON RESISTOR	RN72K1J-123JE	1	435031234R1	NSP
R4068	CHIP TYPE CARBON RESISTOR	RN72K1J-123JE	1	435031234R1	NSP
R4069	CHIP TYPE CARBON RESISTOR	RN72K1J-103JE	1	435031034R1	NSP
R4070	CHIP TYPE CARBON RESISTOR	RN72K1J-103JE	1	435031034R1	NSP
R4071	CHIP TYPE CARBON RESISTOR	RN72K1J-224JE	1	435032244R1	NSP
R4072	CHIP TYPE CARBON RESISTOR	RN72K1J-224JE	1	435032244R1	NSP
R4073	CHIP TYPE CARBON RESISTOR	RN72K1J-000JE	1	435030004R1	NSP
R4074	CHIP TYPE CARBON RESISTOR	RN72K1J-000JE	1	435030004R1	NSP
R4075	CHIP TYPE CARBON RESISTOR	RN72K1J-000JE	1	435030004R1	NSP
R4094	CHIP TYPE CARBON RESISTOR	RN72K1J-102JE	1	435031024R1	NSP
R4095	CHIP TYPE CARBON RESISTOR	RN72K1J-102JE	1	435031024R1	NSP
R4097	CHIP TYPE CARBON RESISTOR	RN72K1J-102JE	1	435031024R1	NSP
R4098	CHIP TYPE CARBON RESISTOR	RN72K1J-102JE	1	435031024R1	NSP
R4101	CHIP TYPE CARBON RESISTOR	RN72K1J-224JE	1	435032244R1	NSP
R4102	CHIP TYPE CARBON RESISTOR	RN72K1J-224JE	1	435032244R1	NSP
R4104	CHIP TYPE CARBON RESISTOR	RN72K1J-223JE	1	435032234R1	NSP
R4111	CHIP TYPE CARBON RESISTOR	RN72K1J-222JE	1	435032224R1	NSP
R4112	CHIP TYPE CARBON RESISTOR	RN72K1J-222JE	1	435032224R1	NSP
R4114	CHIP TYPE CARBON RESISTOR	RN72K1J-271JE	1	435032714R1	NSP
R4124	CHIP TYPE CARBON RESISTOR	RN72K1J-101JE	1	435031014R1	NSP
R4141	CHIP TYPE CARBON RESISTOR	RN72K1J-000JE	1	435030004R1	NSP
R4142	CHIP TYPE CARBON RESISTOR	RN72K1J-000JE	1	435030004R1	NSP
R4154	CHIP TYPE CARBON RESISTOR	RN72K1J-224JE	1	435032244R1	NSP
R4164	CHIP TYPE CARBON RESISTOR	RN72K1J-101JE	1	435031014R1	NSP
R4174	CHIP TYPE CARBON RESISTOR	RN72K1J-101JE	1	435031014R1	NSP
R4175	CHIP TYPE CARBON RESISTOR	RN72K1J-180JE	1	435031804R1	NSP
R4176	CHIP TYPE CARBON RESISTOR	RN72K1J-180JE	1	435031804R1	NSP
R4181	CHIP TYPE CARBON RESISTOR	RN72K1J-102JE	1	435031024R1	NSP
R4182	CHIP TYPE CARBON RESISTOR	RN72K1J-224JE	1	435032244R1	NSP
R4185	CHIP TYPE CARBON RESISTOR	RN72K1J-224JE	1	435032244R1	NSP
R4190	CHIP TYPE CARBON RESISTOR	RN72K1J-221JE	1	435032214R1	NSP
R4191	CHIP TYPE CARBON RESISTOR	RN72K1J-473JE	1	435034734R1	NSP
R4192	CHIP TYPE CARBON RESISTOR	RN72K1J-153JE	1	435031534R1	NSP
R4193	CHIP TYPE CARBON RESISTOR	RN72K1J-122JE	1	435031224R1	NSP
R4194	CHIP TYPE CARBON RESISTOR	RN72K1J-103JE	1	435031034R1	NSP
R4251	METAL RESISTOR	RNU1WCJ-2.2	1	453630224T	NSP
R4252	METAL RESISTOR	RNU1WCJ-2.2	1	453630224T	NSP
R4253	METAL RESISTOR	RNU1WCJ-2.2	1	453630224T	NSP
R4254	METAL RESISTOR	RNU1WCJ-2.2	1	453630224T	NSP
R4255	METAL OXIDE FILM RESISTOR	RS1/2WBJ-15	1	443521504T	NSP
R4256	METAL OXIDE FILM RESISTOR	RS1WBJ-22	1	443622204T	NSP
R4259	METAL OXIDE FILM RESISTOR	RS1/2WBJ-100	1	443521014T	NSP
R4260	METAL OXIDE FILM RESISTOR	RS1/2WBJ-100	1	443521014T	NSP
R4261	METAL OXIDE FILM RESISTOR	RS1/2WBJ-100	1	443521014T	NSP
R4262	METAL OXIDE FILM RESISTOR	RS1/2WBJ-100	1	443521014T	NSP
R4305	CHIP TYPE CARBON RESISTOR	RN72K1J-224JE	1	435032244R1	NSP
R4306	CHIP TYPE CARBON RESISTOR	RN72K1J-224JE	1	435032244R1	NSP
R4307	CHIP TYPE CARBON RESISTOR	RN72K1J-222JE	1	435032224R1	NSP
R4308	CHIP TYPE CARBON RESISTOR	RN72K1J-222JE	1	435032224R1	NSP
R4309	CHIP TYPE CARBON RESISTOR	RN72K1J-224JE	1	435032244R1	NSP
R4310	CHIP TYPE CARBON RESISTOR	RN72K1J-224JE	1	435032244R1	NSP
R4311	CHIP TYPE CARBON RESISTOR	RN72K1J-101JE	1	435031014R1	NSP
R4312	CHIP TYPE CARBON RESISTOR	RN72K1J-101JE	1	435031014R1	NSP



R4531	CHIP TYPE CARBON RESISTOR	RN72K1J-224JE	1	435032244R1	NSP
R4532	CHIP TYPE CARBON RESISTOR	RN72K1J-224JE	1	435032244R1	NSP
R4533	CHIP TYPE CARBON RESISTOR	RN72K1J-561JE	1	435035614R1	NSP
R4534	CHIP TYPE CARBON RESISTOR	RN72K1J-561JE	1	435035614R1	NSP
R4535	CHIP TYPE CARBON RESISTOR	RN72K1J-274JE	1	435032744R1	NSP
R4536	CHIP TYPE CARBON RESISTOR	RN72K1J-274JE	1	435032744R1	NSP
R4537	CHIP TYPE CARBON RESISTOR	RN72K1J-223JE	1	435032234R1	NSP
R4538	CHIP TYPE CARBON RESISTOR	RN72K1J-223JE	1	435032234R1	NSP
R4539	CHIP TYPE CARBON RESISTOR	RN72K1J-000JE	1	435030004R1	NSP
R4540	CHIP TYPE CARBON RESISTOR	RN72K1J-000JE	1	435030004R1	NSP
R4541	CHIP TYPE CARBON RESISTOR	RN72K1J-331JE	1	435033314R1	NSP
R4542	CHIP TYPE CARBON RESISTOR	RN72K1J-331JE	1	435033314R1	NSP
R4543	CHIP TYPE CARBON RESISTOR	RN72K1J-224JE	1	435032244R1	NSP
R4544	CHIP TYPE CARBON RESISTOR	RN72K1J-224JE	1	435032244R1	NSP
R4546	CHIP TYPE CARBON RESISTOR	RN72K1J-220JE	1	435032204R1	NSP
R4547	CHIP TYPE CARBON RESISTOR	RN72K1J-220JE	1	435032204R1	NSP
R5601	CHIP TYPE CARBON RESISTOR	RN72K1J-472FE	1	435034722R1	NSP
R5602	CHIP TYPE CARBON RESISTOR	RN72K1J-472FE	1	435034722R1	NSP
R5721	CHIP TYPE CARBON RESISTOR	RN72K1J-123FE	1	435031232R1	NSP
R5722	CHIP TYPE CARBON RESISTOR	RN72K1J-123FE	1	435031232R1	NSP
R5741	CHIP TYPE CARBON RESISTOR	RN72K1J-472FE	1	435034722R1	NSP
R5742	CHIP TYPE CARBON RESISTOR	RN72K1J-472FE	1	435034722R1	NSP
R5861	CHIP TYPE CARBON RESISTOR	RN72K1J-000JE	1	435030004R1	NSP
R5862	CHIP TYPE CARBON RESISTOR	RN72K1J-000JE	1	435030004R1	NSP
R5881	CHIP TYPE CARBON RESISTOR	RN72K1J-000JE	1	435030004R1	NSP
R5882	CHIP TYPE CARBON RESISTOR	RN72K1J-000JE	1	435030004R1	NSP
R6081	METAL PLATE RESISTOR	MPR5W+5W 0R22	1	4000233	
R6082	METAL PLATE RESISTOR	MPR5W+5W 0R22	1	4000233	
R6141	NON-FLAMMABLE CARBON FILM RESISTO	R25J-0.22	1	415472294T	
R6142	NON-FLAMMABLE CARBON FILM RESISTO	R25J-0.22	1	415472294T	
R6161	NON-FLAMMABLE CARBON FILM RESISTO	R25J-0.22	1	415472294T	
R6162	NON-FLAMMABLE CARBON FILM RESISTO	R25J-0.22	1	415472294T	
R6461	METAL RESISTOR	RNU1WCJ-8.2	1	453630824T	NSP
R6462	METAL RESISTOR	RNU1WCJ-8.2	1	453630824T	NSP
R6601	CHIP TYPE CARBON RESISTOR	RN72K1J-223JE	1	435032234R1	NSP
R6602	CHIP TYPE CARBON RESISTOR	RN72K1J-223JE	1	435032234R1	NSP
R6621	CHIP TYPE CARBON RESISTOR	RN72K1J-223JE	1	435032234R1	NSP
R6622	CHIP TYPE CARBON RESISTOR	RN72K1J-223JE	1	435032234R1	NSP
R6641	CHIP TYPE CARBON RESISTOR	RN72K1J-512JE	1	435035124R1	NSP
R6642	CHIP TYPE CARBON RESISTOR	RN72K1J-512JE	1	435035124R1	NSP
R6661	CHIP TYPE CARBON RESISTOR	RN72K1J-394JE	1	435033944R1	NSP
R6662	CHIP TYPE CARBON RESISTOR	RN72K1J-394JE	1	435033944R1	NSP
R6681	CHIP TYPE CARBON RESISTOR	RN72K1J-333JE	1	435033334R1	NSP
R6682	CHIP TYPE CARBON RESISTOR	RN72K1J-333JE	1	435033334R1	NSP
R6700	CHIP TYPE CARBON RESISTOR	RN72K1J-223JE	1	435032234R1	NSP
R6701	CHIP TYPE CARBON RESISTOR	RN72K1J-223JE	1	435032234R1	NSP
R6702	CHIP TYPE CARBON RESISTOR	RN72K1J-333JE	1	435033334R1	NSP
R6703	CHIP TYPE CARBON RESISTOR	RN72K1J-223JE	1	435032234R1	NSP
R6704	CHIP TYPE CARBON RESISTOR	RN72K1J-224JE	1	435032244R1	NSP
R6705	CHIP TYPE CARBON RESISTOR	RN72K1J-222JE	1	435032224R1	NSP
R6706	CHIP TYPE CARBON RESISTOR	RN72K1J-473JE	1	435034734R1	NSP
R6707	CHIP TYPE CARBON RESISTOR	RN72K1J-223JE	1	435032234R1	NSP
R6708	CHIP TYPE CARBON RESISTOR	RN72K1J-333JE	1	435033334R1	NSP
R6721	CHIP TYPE CARBON RESISTOR	RN72K1J-473JE	1	435034734R1	NSP
R6722	CHIP TYPE CARBON RESISTOR	RN72K1J-473JE	1	435034734R1	NSP

R6731	CHIP TYPE CARBON RESISTOR	RN72K1J-000JE	1	435030004R1	NSP
R6741	CHIP TYPE CARBON RESISTOR	RN72K1J-333JE	1	435033334R1	NSP
R6742	CHIP TYPE CARBON RESISTOR	RN72K1J-103JE	1	435031034R1	NSP
R6743	CHIP TYPE CARBON RESISTOR	RN72K1J-473JE	1	435034734R1	NSP
R6744	CHIP TYPE CARBON RESISTOR	RN72K1J-223JE	1	435032234R1	NSP
R6761	CHIP TYPE CARBON RESISTOR	RN72K1J-473JE	1	435034734R1	NSP
R6762	CHIP TYPE CARBON RESISTOR	RN72K1J-473JE	1	435034734R1	NSP
R6780	CHIP TYPE CARBON RESISTOR	RN72K1J-562JE	1	435035624R1	NSP
R6781	CHIP TYPE CARBON RESISTOR	RN72K1J-562JE	1	435035624R1	NSP
R6792	CHIP TYPE CARBON RESISTOR	RN72K1J-000JE	1	435030004R1	NSP
R6802	CHIP TYPE CARBON RESISTOR	RN72K1J-153FE	1	435031532R1	NSP
R6803	CHIP TYPE CARBON RESISTOR	RN72K1J-473FE	1	435034732R1	NSP
R6804	CHIP TYPE CARBON RESISTOR	RN72K1J-184JE	1	435031844R1	NSP
R6805	CHIP TYPE CARBON RESISTOR	RN72K1J-223FE	1	435032232R1	NSP
R6806	THERMISTOR	PRF18BF471QB5RB	1	4000286R2	NSP
R6808	CHIP TYPE CARBON RESISTOR	RN72K1J-224JE	1	435032244R1	NSP
R6901	METAL RESISTOR	RNU1/2WCJ-0.1	1	453531094T	NSP
R6913	METAL OXIDE FILM RESISTOR	RS1/2WBJ-33	1	443523304T	NSP
<b>[ Switches, Terminals, Wires ]</b>					
F6901C	FUSE HOLDER	NSCT-1P2031	1	25052133T	! NSP
F6901D	FUSE HOLDER	NSCT-1P2031	1	25052133T	! NSP
F6902C	FUSE HOLDER	NSCT-1P2031	1	25052133T	! NSP
F6902D	FUSE HOLDER	NSCT-1P2031	1	25052133T	! NSP
P020	PRINTED WIRING BOARD	BCAF-2388	1	25142388A	NSP
P020A	PRINTED WIRING BOARD	BCAF-2388	{1}	25142388	NSP
P020C	PRINTED WIRING BOARD	BCETC-2390	{1}	25142390	N NSP
P020D	PRINTED WIRING BOARD	BCETC-2391	{1}	25142391	N NSP
P020E	PRINTED WIRING BOARD	BCETC-2392	{1}	25142392	N NSP
P020F	PRINTED WIRING BOARD	BCETC-2393	{1}	25142393	N NSP
P1501B	SOCKET	IMSA-9142S-22A	1	25053233	NSP
P4001	PIN JACK	NPJ-6PDRW665	1	25045894	
P4003	PIN JACK	NPJ-2PDWR583	1	25045803	
P4004	PIN JACK	NPJ-4PDRWB786	1	25046057	
P5506B	RETAINER	(TRM)	1	25060507	NSP
P5509A	RETAINER	(TRM)	1	25060507	NSP
P6001B	PLUG	NPLG-9P0964	1	25056014	NSP
P6002B	PLUG	NPLG-9P0964	1	25056014	NSP
P6021	PLUG	NPLG-2P29	1	25055038	NSP
P6022	PLUG	NPLG-2P29	1	25055038	NSP
P6400A	WIRE HOL	CHD-2.5-3	1	25053540	NSP
P6400Aor	WIRE HOL	NSCT-3P894	(1)	25051107	NSP
P6400B	WIRE HOL	CHD-2.5-3	1	25053540	NSP
P6400Bor	WIRE HOL	NSCT-3P894	(1)	25051107	NSP
P6402A	WIRE HOL	CHD-2.5-7	1	25053542	NSP
P6402Aor	WIRE HOL	NSCT-7P898	(1)	25051111	NSP
P6402B	WIRE HOL	CHD-2.5-7	1	25053542	NSP
P6402Bor	WIRE HOL	NSCT-7P898	(1)	25051111	NSP
P6501	TERMINAL	NTM-2PDMCR399	1	25060471	
P6502	TERMINAL	NTM-2PDMCR399	1	25060471	
P6505	TERMINAL	NTM-2PDMCR399	1	25060471	
P6506	TERMINAL	NTM-2PDMCR399	1	25060471	
P6800	WIRE HARNESS ASSEMBLY	NSAS-5P2109	1	2009991298UL	NSP
P6800A	WIRE HOL	CHD-1.5-5	1	25053536	NSP
P6800Aor	WIRE HOL	NSCT-5P876	(1)	25051089	NSP
P6901	PLUG	NPLG-5P152	1	25055168	NSP



P6902A	CRIMP CORD ASSEMBLY	CRIMP AS	1	2069925150UL	NSP
P6903A	CRIMP CORD ASSEMBLY	CRIMP AS	1	2069925202UL	NSP
P6904A	CRIMP CORD ASSEMBLY	CRIMP AS	1	2069925166UL	NSP
P7002B	SOCKET	NSCT-15P2406	1	25052509	NSP
P7880	WIRE HARNESS ASSEMBLY	NSAS-5P2482	1	2009991613UL	NSP
P7880B	WIRE HOL	CHD-2.5-5	1	25053541	NSP
RL6501	RELAY	NRL-2P5A-DC24-129	1	25065563A	
RL6501or	RELAY	NRL-2P5A-DC24-193	(1)	25065703	
RL6505	RELAY	NRL-2P5A-DC24-129	1	25065563A	
RL6505or	RELAY	NRL-2P5A-DC24-193	(1)	25065703	
RL6911	RELAY	NRL-1P10A-DC12-196	1	25065707	
RL6912	RELAY	NRL-1P10A-DC12-196	1	25065707	

**BADG-2252-2A****<Note>**

1. Parts marked by "NSP" are generally unavailable because they are not in our Master Spare Parts List.
2. The ! mark found on some component parts indicates the importance of the safety factor of the part.  
Therefore, when replacing, be sure to use parts of identical designation.

: NSP

REF. NO.	PART NAME	DESCRIPTION	Q'TY	PART NO. (SN)	REMARKS
<b>[ Semi-conductors ]</b>					
Q3001	HYBRID IC	AM3354BZCZ80	1	22243021R3	NSP
Q3002	HYBRID IC	TC58NVG1S3HTA00B4H	1	222W0155R3	NSP
Q3003	HYBRID IC	NT5CC128M16IP-DI	1	22243076R3	NSP
Q3006	HYBRID IC	PST894A160UR	1	22243226R2	NSP
Q3007	TRANSISTOR	DTC014EEBTL	1	2218690R2	NSP
Q3651	HYBRID IC	KSZ8091RNB	1	22243023R2	NSP
Q3652	HYBRID IC	SN74AUP1T17DCKR	1	222740170R2	NSP
Q3653	HYBRID IC	SN74AUP1T17DCKR	1	222740170R2	NSP
Q3654	HYBRID IC	TC74VCX125FT	1	22274125DR2TO	NSP
Q3664	HYBRID IC	S-13A1A33-U5T1U3	1	22242844R2	NSP
Q3667	TRANSISTOR	DTC014EEBTL	1	2218690R2	NSP
Q3901	HYBRID IC	TPS65910A31A1RSLR	1	22243022R2	NSP
X3001	CRYSTAL	DSX321G_24MHz	1	3010558R2	NSP
X3002	CRYSTAL	FC-135 -32.768K	1	3010532R2	NSP
X3651	CRYSTAL	DSX321G_25MHz	1	3010559R2	NSP
<b>[ Transformers, Coils ]</b>					
L3001	CORE	BLM15PX121SN1D	1	2350034R1	NSP
L3201	C-METAL R	RN72K1J-000JE0	1	435010004R1	NSP
L3202	C-METAL R	RN72K1J-000JE0	1	435010004R1	NSP
L3613	CORE	MCF20104G900-T	1	2350040R2	NSP
L3651	CORE	BLM15PX121SN1D	1	2350034R1	NSP
L3652	CORE	BLM15PX121SN1D	1	2350034R1	NSP
L3655	CORE	BLM15PX121SN1D	1	2350034R1	NSP
L3656	CORE	BLM15PX121SN1D	1	2350034R1	NSP
L3661	CORE	BLM15PX121SN1D	1	2350034R1	NSP
L3901	CHOKE COIL	NRS4018T2R2MDGJ	1	231494R2	NSP
L3902	CHOKE COIL	NRS4018T2R2MDGJ	1	231494R2	NSP
L3903	CHOKE COIL	NRS4018T2R2MDGJ	1	231494R2	NSP

L3904	CORE	BLM15PX121SN1D	1	2350034R1	NSP
L3905	CORE	BLM15PX121SN1D	1	2350034R1	NSP
L3906	CORE	BLM15PX121SN1D	1	2350034R1	NSP
L3907	CORE	BLM15PX121SN1D	1	2350034R1	NSP
L3909	CORE	BLM15PX121SN1D	1	2350034R1	NSP
L3910	CORE	BLM15PX121SN1D	1	2350034R1	NSP
L3911	C-METAL R	RN72K1J-000JE0	1	435010004R1	NSP
<b>[ Capacitors ]</b>					
C3001	CHIP TYPE CERAMIC CAPACITOR	CK725B1A-105K0	1	332001055R1	NSP
C3002	CHIP TYPE CERAMIC CAPACITOR	CK732B16V-106K	1	332071065R2	NSP
C3003	CHIP TYPE CERAMIC CAPACITOR	CK725B1A-105K0	1	332001055R1	NSP
C3004	CHIP TYPE CERAMIC CAPACITOR	CK725B1H-102K0	1	332031025R1	NSP
C3005	CHIP TYPE CERAMIC CAPACITOR	CC725CH1H-180J0	1	342031804R1	NSP
C3006	CHIP TYPE CERAMIC CAPACITOR	CC725CH1H-180J0	1	342031804R1	NSP
C3007	CHIP TYPE CERAMIC CAPACITOR	CC725CH1H-150J0	1	342031504R1	NSP
C3008	CHIP TYPE CERAMIC CAPACITOR	CC725CH1H-150J0	1	342031504R1	NSP
C3009	CHIP TYPE CERAMIC CAPACITOR	CK725B1H-102K0	1	332031025R1	NSP
C3010	CHIP TYPE CERAMIC CAPACITOR	CK725B1A-105K0	1	332001055R1	NSP
C3011	CHIP TYPE CERAMIC CAPACITOR	CK725B1H-102K0	1	332031025R1	NSP
C3012	CHIP TYPE CERAMIC CAPACITOR	CK725B1A-105K0	1	332001055R1	NSP
C3013	CHIP TYPE CERAMIC CAPACITOR	CK725B1H-102K0	1	332031025R1	NSP
C3014	CHIP TYPE CERAMIC CAPACITOR	CK725B1H-102K0	1	332031025R1	NSP
C3015	CHIP TYPE CERAMIC CAPACITOR	CK725B1C-104K0	1	332011045R1	NSP
C3016	CHIP TYPE CERAMIC CAPACITOR	CK725B0J-226M	1	332092267R2	NSP
C3018	CHIP TYPE CERAMIC CAPACITOR	CK725B1C-104K0	1	332011045R1	NSP
C3019	CHIP TYPE CERAMIC CAPACITOR	CC725CH1H-100J0	1	342031004R1	NSP
C3020	CHIP TYPE CERAMIC CAPACITOR	CK725B1C-104K0	1	332011045R1	NSP
C3021	CHIP TYPE CERAMIC CAPACITOR	CK725B1C-104K0	1	332011045R1	NSP
C3022	CHIP TYPE CERAMIC CAPACITOR	CC725CH1H-470J0	1	342034704R1	NSP
C3023	CHIP TYPE CERAMIC CAPACITOR	CK725B1C-104K0	1	332011045R1	NSP
C3024	CHIP TYPE CERAMIC CAPACITOR	CK725B1A-224K0	1	332002245R1	NSP
C3025	CHIP TYPE CERAMIC CAPACITOR	CK725B1C-104K0	1	332011045R1	NSP
C3026	CHIP TYPE CERAMIC CAPACITOR	CK725B1C-104K0	1	332011045R1	NSP
C3027	CHIP TYPE CERAMIC CAPACITOR	CC725CH1H-470J0	1	342034704R1	NSP
C3028	CHIP TYPE CERAMIC CAPACITOR	CK725B1C-104K0	1	332011045R1	NSP
C3029	CHIP TYPE CERAMIC CAPACITOR	CC725CH1H-101J0	1	342031014R1	NSP
C3030	CHIP TYPE CERAMIC CAPACITOR	CC725CH1H-101J0	1	342031014R1	NSP
C3031	CHIP TYPE CERAMIC CAPACITOR	CK725B1C-104K0	1	332011045R1	NSP
C3032	CHIP TYPE CERAMIC CAPACITOR	CK725B1C-104K0	1	332011045R1	NSP
C3155	CHIP TYPE CERAMIC CAPACITOR	CK725B1A-105K0	1	332001055R1	NSP
C3202	CHIP TYPE CERAMIC CAPACITOR	CK725B1C-104K0	1	332011045R1	NSP
C3651	CHIP TYPE CERAMIC CAPACITOR	CK725B1A-105K0	1	332001055R1	NSP
C3652	CHIP TYPE CERAMIC CAPACITOR	CK725B0J-226M	1	332092267R2	NSP
C3654	CHIP TYPE CERAMIC CAPACITOR	CK725B1C-104K0	1	332011045R1	NSP
C3656	CHIP TYPE CERAMIC CAPACITOR	CK725B1C-104K0	1	332011045R1	NSP
C3657	CHIP TYPE CERAMIC CAPACITOR	CK725B1C-104K0	1	332011045R1	NSP
C3661	CHIP TYPE CERAMIC CAPACITOR	CK725B1H-102K0	1	332031025R1	NSP
C3662	CHIP TYPE CERAMIC CAPACITOR	CK725B0J-226M	1	332092267R2	NSP
C3663	CHIP TYPE CERAMIC CAPACITOR	CK725B1A-225K1	1	332132255R1	NSP
C3664	CHIP TYPE CERAMIC CAPACITOR	CK725B0J-226M	1	332092267R2	NSP
C3665	CHIP TYPE CERAMIC CAPACITOR	CK725B0J-226M	1	332092267R2	NSP
C3666	CHIP TYPE CERAMIC CAPACITOR	CC725CH1H-150J0	1	342031504R1	NSP
C3667	CHIP TYPE CERAMIC CAPACITOR	CC725CH1H-150J0	1	342031504R1	NSP
C3668	CHIP TYPE CERAMIC CAPACITOR	CK725B1C-104K0	1	332011045R1	NSP
C3669	CHIP TYPE CERAMIC CAPACITOR	CK725B1C-104K0	1	332011045R1	NSP

C3670	CHIP TYPE CERAMIC CAPACITOR	CK725B1C-104K0	1	332011045R1	NSP
C3682	CHIP TYPE CERAMIC CAPACITOR	CK732B16V-106K	1	332071065R2	NSP
C3683	CHIP TYPE CERAMIC CAPACITOR	CK725B0J-226M	1	332092267R2	NSP
C3685	CHIP TYPE CERAMIC CAPACITOR	CK732B16V-106K	1	332071065R2	NSP
C3686	CHIP TYPE CERAMIC CAPACITOR	CK725B1A-105K0	1	332001055R1	NSP
C3689	CHIP TYPE CERAMIC CAPACITOR	CK725B1H-223K0	1	332032235R1	NSP
C3690	CHIP TYPE CERAMIC CAPACITOR	CC725CH1H-221J0	1	342032214R1	NSP
C3691	CHIP TYPE CERAMIC CAPACITOR	CC725CH1H-100J0	1	342031004R1	NSP
C3692	CHIP TYPE CERAMIC CAPACITOR	CC725CH1H-050C0	1	342030501R1	NSP
C3695	CHIP TYPE CERAMIC CAPACITOR	CC725CH1H-101J0	1	342031014R1	NSP
C3800	CHIP TYPE CERAMIC CAPACITOR	CK725B1H-103K0	1	332031035R1	NSP
C3801	CHIP TYPE CERAMIC CAPACITOR	CK725B1H-103K0	1	332031035R1	NSP
C3802	CHIP TYPE CERAMIC CAPACITOR	CK725B1H-103K0	1	332031035R1	NSP
C3803	CHIP TYPE CERAMIC CAPACITOR	CK725B1H-103K0	1	332031035R1	NSP
C3804	CHIP TYPE CERAMIC CAPACITOR	CK725B1H-103K0	1	332031035R1	NSP
C3805	CHIP TYPE CERAMIC CAPACITOR	CK725B1H-103K0	1	332031035R1	NSP
C3806	CHIP TYPE CERAMIC CAPACITOR	CK725B1H-103K0	1	332031035R1	NSP
C3810	CHIP TYPE CERAMIC CAPACITOR	CC725CH1H-221J0	1	342032214R1	NSP
C3811	CHIP TYPE CERAMIC CAPACITOR	CC725CH1H-221J0	1	342032214R1	NSP
C3901	CHIP TYPE CERAMIC CAPACITOR	CK725B1A-475K1	1	332134755R1	NSP
C3902	CHIP TYPE CERAMIC CAPACITOR	CK725B1A-225K1	1	332132255R1	NSP
C3903	CHIP TYPE CERAMIC CAPACITOR	CK725B1A-225K1	1	332132255R1	NSP
C3904	CHIP TYPE CERAMIC CAPACITOR	CK732B16V-106K	1	332071065R2	NSP
C3905	CHIP TYPE CERAMIC CAPACITOR	CK725B1A-475K1	1	332134755R1	NSP
C3906	CHIP TYPE CERAMIC CAPACITOR	CK725B1A-225K1	1	332132255R1	NSP
C3907	CHIP TYPE CERAMIC CAPACITOR	CK725B1A-225K1	1	332132255R1	NSP
C3908	CHIP TYPE CERAMIC CAPACITOR	CK732B16V-106K	1	332071065R2	NSP
C3909	CHIP TYPE CERAMIC CAPACITOR	CK725B1C-104K0	1	332011045R1	NSP
C3910	CHIP TYPE CERAMIC CAPACITOR	CK725B1A-225K1	1	332132255R1	NSP
C3911	CHIP TYPE CERAMIC CAPACITOR	CK725B1A-225K1	1	332132255R1	NSP
C3912	CHIP TYPE CERAMIC CAPACITOR	CK725B1A-475K1	1	332134755R1	NSP
C3913	CHIP TYPE CERAMIC CAPACITOR	CK725B1A-475K1	1	332134755R1	NSP
C3914	CHIP TYPE CERAMIC CAPACITOR	CK725B1A-225K1	1	332132255R1	NSP
C3915	CHIP TYPE CERAMIC CAPACITOR	CK732B16V-106K	1	332071065R2	NSP
C3916	CHIP TYPE CERAMIC CAPACITOR	CK732B16V-106K	1	332071065R2	NSP
C3917	CHIP TYPE CERAMIC CAPACITOR	CK732B16V-106K	1	332071065R2	NSP
C3918	CHIP TYPE CERAMIC CAPACITOR	CK732B16V-106K	1	332071065R2	NSP
C3919	CHIP TYPE CERAMIC CAPACITOR	CK725B1A-475K1	1	332134755R1	NSP
C3920	CHIP TYPE CERAMIC CAPACITOR	CK725B1A-225K1	1	332132255R1	NSP
C3921	CHIP TYPE CERAMIC CAPACITOR	CK725B1A-225K1	1	332132255R1	NSP
C3922	CHIP TYPE CERAMIC CAPACITOR	CK732B16V-106K	1	332071065R2	NSP
C3923	CHIP TYPE CERAMIC CAPACITOR	CK725B1H-103K0	1	332031035R1	NSP
C3924	CHIP TYPE CERAMIC CAPACITOR	CK725B1H-103K0	1	332031035R1	NSP
C3925	CHIP TYPE CERAMIC CAPACITOR	CK725B1H-103K0	1	332031035R1	NSP
C3926	CHIP TYPE CERAMIC CAPACITOR	CK725B1H-103K0	1	332031035R1	NSP
C3927	CHIP TYPE CERAMIC CAPACITOR	CK725B1H-103K0	1	332031035R1	NSP
C3928	CHIP TYPE CERAMIC CAPACITOR	CK732B16V-106K	1	332071065R2	NSP
C3929	CHIP TYPE CERAMIC CAPACITOR	CK732B16V-106K	1	332071065R2	NSP
C3930	CHIP TYPE CERAMIC CAPACITOR	CK725B1C-104K0	1	332011045R1	NSP
C3931	CHIP TYPE CERAMIC CAPACITOR	CK725B1C-104K0	1	332011045R1	NSP
C3932	CHIP TYPE CERAMIC CAPACITOR	CK725B1C-104K0	1	332011045R1	NSP
C3933	CHIP TYPE CERAMIC CAPACITOR	CC725CH1H-470J0	1	342034704R1	NSP
C3934	CHIP TYPE CERAMIC CAPACITOR	CC725CH1H-101J0	1	342031014R1	NSP
C3935	CHIP TYPE CERAMIC CAPACITOR	CK725B1C-104K0	1	332011045R1	NSP
C3936	CHIP TYPE CERAMIC CAPACITOR	CK725B1C-104K0	1	332011045R1	NSP



C3992	CHIP TYPE CERAMIC CAPACITOR	CK725B1H-103K0	1	332031035R1	NSP
C3993	CHIP TYPE CERAMIC CAPACITOR	CK725B1C-104K0	1	332011045R1	NSP
C3994	CHIP TYPE CERAMIC CAPACITOR	CC725CH1H-471J0	1	342034714R1	NSP
C3995	CHIP TYPE CERAMIC CAPACITOR	CK725B1H-103K0	1	332031035R1	NSP
C3996	CHIP TYPE CERAMIC CAPACITOR	CC725CH1H-470J0	1	342034704R1	NSP
C3997	CHIP TYPE CERAMIC CAPACITOR	CK725B1H-103K0	1	332031035R1	NSP
C3998	CHIP TYPE CERAMIC CAPACITOR	CK732B16V-106K	1	332071065R2	NSP
C3999	CHIP TYPE CERAMIC CAPACITOR	CK725B1H-103K0	1	332031035R1	NSP
<b>[ Resistors ]</b>					
R3009	C-METAL R	RN72K1J-102JE0	1	435011024R1	NSP
R3010	C-METAL R	RN72K1J-475JE0	1	435014754R1	NSP
R3011	C-METAL R	RN72K1J-105JE0	1	435011054R1	NSP
R3012	C-METAL R	RN72K1J-220JE0	1	435012204R1	NSP
R3013	C-METAL R	RN72K1J-220JE0	1	435012204R1	NSP
R3014	C-METAL R	RN72K1J-220JE0	1	435012204R1	NSP
R3015	C-METAL R	RN72K1J-220JE0	1	435012204R1	NSP
R3016	C-METAL R	RN72K1J-220JE0	1	435012204R1	NSP
R3017	C-METAL R	RN72K1J-220JE0	1	435012204R1	NSP
R3018	C-METAL R	RN72K1J-220JE0	1	435012204R1	NSP
R3019	C-METAL R	RN72K1J-472JE0	1	435014724R1	NSP
R3020	C-METAL R	RN72K1J-103JE0	1	435011034R1	NSP
R3021	C-METAL R	RN72K1J-103JE0	1	435011034R1	NSP
R3022	C-METAL R	RN72K1J-470JE0	1	435014704R1	NSP
R3023	C-METAL R	RN72K1J-470JE0	1	435014704R1	NSP
R3028	C-METAL R	RN72K1J-103JE0	1	435011034R1	NSP
R3029	C-METAL R	RN72K1J-102JE0	1	435011024R1	NSP
R3030	C-METAL R	RN72K1J-223JE0	1	435012234R1	NSP
R3031	C-METAL R	RN72K1J-104JE0	1	435011044R1	NSP
R3032	C-METAL R	RN72K1J-470JE0	1	435014704R1	NSP
R3033	C-METAL R	RN72K1J-470JE0	1	435014704R1	NSP
R3034	C-METAL R	RN72K1J-470JE0	1	435014704R1	NSP
R3035	C-METAL R	RN72K1J-102JE0	1	435011024R1	NSP
R3036	C-METAL R	RN72K1J-470JE0	1	435014704R1	NSP
R3037	C-METAL R	RN72K1J-470JE0	1	435014704R1	NSP
R3038	C-METAL R	RN72K1J-470JE0	1	435014704R1	NSP
R3039	C-METAL R	RN72K1J-470JE0	1	435014704R1	NSP
R3040	CHIP TYPE CARBON RESISTOR	MCR03EZPF49R9(49.9_1%)	1	4100037R2	NSP
R3041	C-METAL R	RN72K1J-271FE0	1	435012712R1	NSP
R3042	C-METAL R	RN72K1J-222FE0	1	435012222R1	NSP
R3043	C-METAL R	RN72K1J-103FE0	1	435011032R1	NSP
R3044	C-METAL R	RN72K1J-103FE0	1	435011032R1	NSP
R3045	C-METAL R	RN72K1J-102FE0	1	435011022R1	NSP
R3046	C-METAL R	RN72K1J-102FE0	1	435011022R1	NSP
R3077	C-METAL R	RN72K1J-000JE0	1	435010004R1	NSP
R3078	C-METAL R	RN72K1J-391JE0	1	435013914R1	NSP
R3079	C-METAL R	RN72K1J-475JE0	1	435014754R1	NSP
R3080	C-METAL R	RN72K1J-475JE0	1	435014754R1	NSP
R3081	CHIP RESISTOR NETWORK	MNR04MRAPJ470	1	43464747004R2	NSP
R3081or	CHIP RESISTOR NETWORK	YCN104-470-JK	(1)	43464C47004R1	NSP
R3082	CHIP RESISTOR NETWORK	MNR04MRAPJ470	1	43464747004R2	NSP
R3082or	CHIP RESISTOR NETWORK	YCN104-470-JK	(1)	43464C47004R1	NSP
R3083	CHIP RESISTOR NETWORK	MNR04MRAPJ470	1	43464747004R2	NSP
R3083or	CHIP RESISTOR NETWORK	YCN104-470-JK	(1)	43464C47004R1	NSP
R3201	C-METAL R	RN72K1J-470JE0	1	435014704R1	NSP
R3202	C-METAL R	RN72K1J-470JE0	1	435014704R1	NSP



R3324	C-METAL R	RN72K1J-220JE0	1	435012204R1	NSP
R3325	CHIP RESISTOR NETWORK	MNR04MRAPJ470	1	43464747004R2	NSP
R3325or	CHIP RESISTOR NETWORK	YCN104-470-JK	(1)	43464C47004R1	NSP
R3326	C-METAL R	RN72K1J-470JE0	1	435014704R1	NSP
R3327	C-METAL R	RN72K1J-470JE0	1	435014704R1	NSP
R3328	C-METAL R	RN72K1J-470JE0	1	435014704R1	NSP
R3329	C-METAL R	RN72K1J-470JE0	1	435014704R1	NSP
R3330	C-METAL R	RN72K1J-220JE0	1	435012204R1	NSP
R3331	C-METAL R	RN72K1J-220JE0	1	435012204R1	NSP
R3332	C-METAL R	RN72K1J-470JE0	1	435014704R1	NSP
R3333	C-METAL R	RN72K1J-470JE0	1	435014704R1	NSP
R3334	C-METAL R	RN72K1J-470JE0	1	435014704R1	NSP
R3335	C-METAL R	RN72K1J-470JE0	1	435014704R1	NSP
R3336	C-METAL R	RN72K1J-470JE0	1	435014704R1	NSP
R3337	C-METAL R	RN72K1J-470JE0	1	435014704R1	NSP
R3338	C-METAL R	RN72K1J-470JE0	1	435014704R1	NSP
R3339	C-METAL R	RN72K1J-470JE0	1	435014704R1	NSP
R3340	C-METAL R	RN72K1J-470JE0	1	435014704R1	NSP
R3341	C-METAL R	RN72K1J-470JE0	1	435014704R1	NSP
R3342	C-METAL R	RN72K1J-470JE0	1	435014704R1	NSP
R3343	C-METAL R	RN72K1J-470JE0	1	435014704R1	NSP
R3344	C-METAL R	RN72K1J-470JE0	1	435014704R1	NSP
R3345	C-METAL R	RN72K1J-220JE0	1	435012204R1	NSP
R3346	C-METAL R	RN72K1J-470JE0	1	435014704R1	NSP
R3347	C-METAL R	RN72K1J-103JE0	1	435011034R1	NSP
R3348	C-METAL R	RN72K1J-470JE0	1	435014704R1	NSP
R3349	C-METAL R	RN72K1J-472JE0	1	435014724R1	NSP
R3350	C-METAL R	RN72K1J-472JE0	1	435014724R1	NSP
R3351	CHIP RESISTOR NETWORK	MNR04MRAPJ103	1	43464710304R2	NSP
R3351or	CHIP RESISTOR NETWORK	YCN104-103-JK	(1)	43464C10304R1	NSP
R3352	CHIP RESISTOR NETWORK	MNR04MRAPJ103	1	43464710304R2	NSP
R3352or	CHIP RESISTOR NETWORK	YCN104-103-JK	(1)	43464C10304R1	NSP
R3353	CHIP RESISTOR NETWORK	MNR04MRAPJ220	1	43464722004R2	NSP
R3353or	CHIP RESISTOR NETWORK	YCN104-220-JK	(1)	43464C22004R1	NSP
R3354	CHIP RESISTOR NETWORK	MNR04MRAPJ220	1	43464722004R2	NSP
R3354or	CHIP RESISTOR NETWORK	YCN104-220-JK	(1)	43464C22004R1	NSP
R3355	CHIP RESISTOR NETWORK	MNR04MRAPJ220	1	43464722004R2	NSP
R3355or	CHIP RESISTOR NETWORK	YCN104-220-JK	(1)	43464C22004R1	NSP
R3356	CHIP RESISTOR NETWORK	MNR04MRAPJ220	1	43464722004R2	NSP
R3356or	CHIP RESISTOR NETWORK	YCN104-220-JK	(1)	43464C22004R1	NSP
R3357	C-METAL R	RN72K1J-103JE0	1	435011034R1	NSP
R3358	C-METAL R	RN72K1J-103JE0	1	435011034R1	NSP
R3360	C-METAL R	RN72K1J-472JE0	1	435014724R1	NSP
R3361	C-METAL R	RN72K1J-103JE0	1	435011034R1	NSP
R3366	C-METAL R	RN72K1J-000JE0	1	435010004R1	NSP
R3367	C-METAL R	RN72K1J-470JE0	1	435014704R1	NSP
R3369	C-METAL R	RN72K1J-472JE0	1	435014724R1	NSP
R3370	C-METAL R	RN72K1J-470JE0	1	435014704R1	NSP
R3371	C-METAL R	RN72K1J-470JE0	1	435014704R1	NSP
R3373	C-METAL R	RN72K1J-472JE0	1	435014724R1	NSP
R3375	C-METAL R	RN72K1J-470JE0	1	435014704R1	NSP
R3603	C-METAL R	RN72K1J-103JE0	1	435011034R1	NSP
R3604	C-METAL R	RN72K1J-103JE0	1	435011034R1	NSP
R3652	C-METAL R	RN72K1J-220JE0	1	435012204R1	NSP
R3653	C-METAL R	RN72K1J-102JE0	1	435011024R1	NSP

R3654	C-METAL R	RN72K1J-102JE0	1	435011024R1	NSP
R3657	C-METAL R	RN72K1J-220JE0	1	435012204R1	NSP
R3658	C-METAL R	RN72K1J-391FE0	1	435013912R1	NSP
R3659	C-METAL R	RN72K1J-222FE0	1	435012222R1	NSP
R3660	C-METAL R	RN72K1J-392FE0	1	435013922R1	NSP
R3661	C-METAL R	RN72K1J-220JE0	1	435012204R1	NSP
R3662	C-METAL R	RN72K1J-220JE0	1	435012204R1	NSP
R3663	C-METAL R	RN72K1J-472JE0	1	435014724R1	NSP
R3664	C-METAL R	RN72K1J-220JE0	1	435012204R1	NSP
R3666	C-METAL R	RN72K1J-220JE0	1	435012204R1	NSP
R3667	C-METAL R	RN72K1J-470JE0	1	435014704R1	NSP
R3668	C-METAL R	RN72K1J-472JE0	1	435014724R1	NSP
R3669	C-METAL R	RN72K1J-472JE0	1	435014724R1	NSP
R3670	C-METAL R	RN72K1J-472JE0	1	435014724R1	NSP
R3671	C-METAL R	RN72K1J-472JE0	1	435014724R1	NSP
R3674	C-METAL R	RN72K1J-224JE0	1	435012244R1	NSP
R3675	C-METAL R	RN72K1J-102JE0	1	435011024R1	NSP
R3676	C-METAL R	RN72K1J-222JE0	1	435012224R1	NSP
R3678	C-METAL R	RN72K1J-472JE0	1	435014724R1	NSP
R3679	C-METAL R	RN72K1J-472JE0	1	435014724R1	NSP
R3692	C-METAL R	RN72K1J-470JE0	1	435014704R1	NSP
R3693	C-METAL R	RN72K1J-470JE0	1	435014704R1	NSP
R3694	C-METAL R	RN72K1J-470JE0	1	435014704R1	NSP
R3695	C-METAL R	RN72K1J-470JE0	1	435014704R1	NSP
R3696	C-METAL R	RN72K1J-470JE0	1	435014704R1	NSP
R3697	C-METAL R	RN72K1J-470JE0	1	435014704R1	NSP
R3699	C-METAL R	RN72K1J-470JE0	1	435014704R1	NSP
R3700	C-METAL R	RN72K1J-470JE0	1	435014704R1	NSP
R3701	C-METAL R	RN72K1J-470JE0	1	435014704R1	NSP
R3710	C-METAL R	RN72K1J-220JE0	1	435012204R1	NSP
R3712	C-METAL R	RN72K1J-103JE0	1	435011034R1	NSP
R3714	C-METAL R	RN72K1J-470JE0	1	435014704R1	NSP
R3715	C-METAL R	RN72K1J-472JE0	1	435014724R1	NSP
R3719	C-METAL R	RN72K1J-000JE0	1	435010004R1	NSP
R3728	C-METAL R	RN72K1J-103JE0	1	435011034R1	NSP
R3729	C-METAL R	RN72K1J-470JE0	1	435014704R1	NSP
R3731	C-METAL R	RN72K1J-220JE0	1	435012204R1	NSP
R3732	C-METAL R	RN72K1J-103JE0	1	435011034R1	NSP
R3733	C-METAL R	RN72K1J-103JE0	1	435011034R1	NSP
R3734	C-METAL R	RN72K1J-103JE0	1	435011034R1	NSP
R3735	C-METAL R	RN72K1J-103JE0	1	435011034R1	NSP
R3737	C-METAL R	RN72K1J-220JE0	1	435012204R1	NSP
R3739	C-METAL R	RN72K1J-220JE0	1	435012204R1	NSP
R3741	C-METAL R	RN72K1J-220JE0	1	435012204R1	NSP
R3743	C-METAL R	RN72K1J-220JE0	1	435012204R1	NSP
R3745	C-METAL R	RN72K1J-220JE0	1	435012204R1	NSP
R3746	C-METAL R	RN72K1J-220JE0	1	435012204R1	NSP
R3747	C-METAL R	RN72K1J-220JE0	1	435012204R1	NSP
R3750	C-METAL R	RN72K1J-220JE0	1	435012204R1	NSP
R3751	C-METAL R	RN72K1J-220JE0	1	435012204R1	NSP
R3752	C-METAL R	RN72K1J-220JE0	1	435012204R1	NSP
R3753	C-METAL R	RN72K1J-103JE0	1	435011034R1	NSP
R3754	C-METAL R	RN72K1J-103JE0	1	435011034R1	NSP
R3758	C-METAL R	RN72K1J-000JE0	1	435010004R1	NSP
R3902	C-METAL R	RN72K1J-103JE0	1	435011034R1	NSP



R3903	C-METAL R	RN72K1J-103JE0	1	435011034R1	NSP
R3904	C-METAL R	RN72K1J-122JE0	1	435011224R1	NSP
R3905	C-METAL R	RN72K1J-122JE0	1	435011224R1	NSP
R3906	C-METAL R	RN72K1J-103JE0	1	435011034R1	NSP
R3908	C-METAL R	RN72K1J-103JE0	1	435011034R1	NSP
R3911	C-METAL R	RN72K1J-470JE0	1	435014704R1	NSP
R3912	C-METAL R	RN72K1J-470JE0	1	435014704R1	NSP
R3915	C-METAL R	RN72K1J-000JE0	1	435010004R1	NSP
R3916	C-METAL R	RN72K1J-000JE0	1	435010004R1	NSP
R3917	C-METAL R	RN72K1J-000JE0	1	435010004R1	NSP
R3918	C-METAL R	RN72K1J-000JE0	1	435010004R1	NSP
R3920	C-METAL R	RN72K1J-470JE0	1	435014704R1	NSP
R3999	C-METAL R	RN72K1J-000JE0	1	435010004R1	NSP
<b>[ Switches, Terminals, Wires ]</b>					
P040	PRINTED WIRING BOARD	BCDG-2252	1	25142252A	<b>N</b> NSP
P3654	SOCKET	APCI0154-P001A	1	25053642R2	NSP
P3658	TERMINAL	APCI0218-K001A	1	25060551R2	NSP
P3901	SOCKET	JF-72PIN-V	1	25053639R2	NSP
P3902	SOCKET	JF-32PIN-V	1	25053638R2	NSP

**BADIS-2394-1C****<Note>**

1. Parts marked by "**NSP**" are generally unavailable because they are not in our Master Spare Parts List.
2. The ! mark found on some component parts indicates the importance of the safety factor of the part.  
Therefore, when replacing, be sure to use parts of identical designation.

: NSP

REF. NO.	PART NAME	DESCRIPTION	Q'TY	PART NO. (SN)	REMARKS
<b>[ Semi-conductors ]</b>					
D1500	PHOTO COUPLER	JSR1165-001recieving	1	24120143	
D1501	PHOTO COUPLER	JSR1165-001recieving	1	24120143	
D2000	DIODE	G10XB80-02-54A-T	1	22380378	
D2000A	HEAT SINK	RAD-083	1	27160271	NSP
D2000B	SCREW	3P+10FN(3BC)	1	82143010GR	NSP
D2001	CHIP TYPE DIODE	DA2J10100	1	223303R2	NSP
D2002	CHIP TYPE DIODE	DA2J10100	1	223303R2	NSP
D2003	ZENER DIODE	DZ2J062M0L	1	224760620R2	NSP
D2005	DIODE	RBR3MM30ATR	1	22380401R2	NSP
D2501	DIODE	CUS357	1	223320R2	NSP
D5081	ZENER DIODE	DZ2J056M0L	1	224760560R2	NSP
D5082	ZENER DIODE	DZ2J056M0L	1	224760560R2	NSP
D7500	ZENER DIODE	DZ2J039M0L	1	224760390R2	NSP
D7750	LED	HLMP-Y701	1	225528	
D7762	CHIP TYPE DIODE	DA2J10100	1	223303R2	NSP
D7763	CHIP TYPE DIODE	DA2J10100	1	223303R2	NSP
D7900	DIODE	RL1N4003	1	22380260T	NSP
D7904	ZENER DIODE	DZ2J200M0L	1	224762000R2	NSP
D7905	ZENER DIODE	DZ2J180M0L	1	224761800R2	NSP
D7906	ZENER DIODE	DZ2J075M0L	1	224760750R2	NSP
D9001	DIODE	S1WB(A)60B-7062	1	22380377R2	NSP

D9002	SPECIFIED DIODE	SMBJP6KE200A-TP	1	225551R2	NSP
D9002or	SPECIFIED DIODE	P6SMB200A-M3/52T	(1)	225505R2	NSP
D9003	DIODE	GU1M-60A-2	1	22380405R2	NSP
D9003or	DIODE	US1K-E3/61T	(1)	22380376R2	NSP
D9004	DIODE	RF301BM2STL	1	22380388R2	NSP
D9006	DIODE	M1FL20U	1	223276R2	NSP
D9008	DIODE	RBR3MM30ATR	1	22380401R2	NSP
D9011	CHIP TYPE DIODE	DA2J10100	1	223303R2	NSP
D9012	ZENER DIODE	DZ2J360M0L	1	224763600R2	NSP
D9013	SPECIFIED DIODE	SMBJP6KE20A-TP	1	225552R2	NSP
D9013or	SPECIFIED DIODE	P6SMB20A-M3/52	(1)	225515R2	NSP
D9018	ZENER DIODE	DZ2J200M0L	1	224762000R2	NSP
Q1	HYBRID IC	RZ5B801-0001E2	1	22242835R2	NSP
Q1500	HYBRID IC	TC7WU04FU	1	22240935R2	NSP
Q1501	HYBRID IC	NJM4580CG	1	22242922R2	NSP
Q1502	HYBRID IC	NJM4580CG	1	22242922R2	NSP
Q1503	HYBRID IC	NJM4580CG	1	22242922R2	NSP
Q1504	HYBRID IC	NJM4580CG	1	22242922R2	NSP
Q2501	TRANSISTOR	KRC102S	1	2216190R2	NSP
Q2501or	TRANSISTOR	DTC114ECAT116	(1)	2219010R2	NSP
Q2502	TRANSISTOR	KRA102S	1	2216220R2	NSP
Q2502or	TRANSISTOR	DTA114ECAT116	(1)	2218980R2	NSP
Q2801	TRANSISTOR	KTA1040D	1	2218210R2	NSP
Q2802	TRANSISTOR	2SA1162-GR	1	2214375R2	NSP
Q2803	TRANSISTOR	2SC2712-GR	1	2213145R2	NSP
Q2804	TRANSISTOR	2SA1162-GR	1	2214375R2	NSP
Q2805	TRANSISTOR	INA5001AP1-T111	1	2218030R2	NSP
Q2806	TRANSISTOR	2SA1162-GR	1	2214375R2	NSP
Q2807	TRANSISTOR	2SC2712-GR	1	2213145R2	NSP
Q2808	TRANSISTOR	2SA1162-GR	1	2214375R2	NSP
Q5101	TRANSISTOR	2SC2713-BL	1	2213136R2	
Q5102	TRANSISTOR	2SC2713-BL	1	2213136R2	
Q5121	TRANSISTOR	2SC2713-BL	1	2213136R2	
Q5122	TRANSISTOR	2SC2713-BL	1	2213136R2	
Q5221	TRANSISTOR	INC5001AP1-T111	1	2218100R2	
Q5221or	TRANSISTOR	2SC2881-Y	(1)	2217564AR2	
Q5222	TRANSISTOR	INC5001AP1-T111	1	2218100R2	
Q5222or	TRANSISTOR	2SC2881-Y	(1)	2217564AR2	
Q5381	TRANSISTOR	INA6006AP1-T111	1	2217980R2	
Q5381or	TRANSISTOR	2SA1200-Y(2LONK_ZE)	(1)	2217584R2	
Q5382	TRANSISTOR	INA6006AP1-T111	1	2217980R2	
Q5382or	TRANSISTOR	2SA1200-Y(2LONK_ZE)	(1)	2217584R2	
Q5401	TRANSISTOR	INC6006AP1-T111	1	2217990R2	
Q5401or	TRANSISTOR	2SC2880-Y(2LONK_ZE)	(1)	2217594R2	
Q5402	TRANSISTOR	INC6006AP1-T111	1	2217990R2	
Q5402or	TRANSISTOR	2SC2880-Y(2LONK_ZE)	(1)	2217594R2	
Q5421	TRANSISTOR	INA6006AP1-T111	1	2217980R2	
Q5421or	TRANSISTOR	2SA1200-Y(2LONK_ZE)	(1)	2217584R2	
Q5422	TRANSISTOR	INA6006AP1-T111	1	2217980R2	
Q5422or	TRANSISTOR	2SA1200-Y(2LONK_ZE)	(1)	2217584R2	
Q5441	TRANSISTOR	INC6006AP1-T111	1	2217990R2	
Q5441or	TRANSISTOR	2SC2880-Y(2LONK_ZE)	(1)	2217594R2	
Q5442	TRANSISTOR	INC6006AP1-T111	1	2217990R2	
Q5442or	TRANSISTOR	2SC2880-Y(2LONK_ZE)	(1)	2217594R2	
Q5641	TRANSISTOR	2SA1163-BL	1	2216756R2	

Q5642	TRANSISTOR	2SA1163-BL	1	2216756R2	NSP
Q7500	TRANSISTOR	2SC2712-GR	1	2213145R2	NSP
Q7500or	TRANSISTOR	KTC3875-GR	(1)	2216175R2	NSP
Q7780	REMOTE SENSOR	IRM-3638M3S28	1	24130026	
Q7900	TRANSISTOR	INC5001AP1-T111	1	2218100R2	NSP
Q7901	TRANSISTOR	INA5001AP1-T111	1	2218030R2	NSP
Q7901or	TRANSISTOR	KTA1661-Y	(1)	2217864R2	NSP
Q7902	TRANSISTOR	KRC107S	1	2216340R2	NSP
Q7902or	TRANSISTOR	DTC114YCAT116	(1)	2219050R2	NSP
Q7903	TRANSISTOR	2SC2712-GR	1	2213145R2	NSP
Q7903or	TRANSISTOR	KTC3875-GR	(1)	2216175R2	NSP
Q7904	TRANSISTOR	2SC2712-GR	1	2213145R2	NSP
Q7904or	TRANSISTOR	KTC3875-GR	(1)	2216175R2	NSP
Q7905	FLUORESCENT TUBE	016MT096GINYK	1	212285A	
Q7905A	HOLDER	(FL)	1	27191414	NSP
Q9001	HYBRID IC	STR-A6051M	1	222154	
Q9003	HYBRID IC	EL816MX	1	22242845	
Q9004	HYBRID IC	KIA431A-AT/P	1	22242770T	NSP
Q9005	TRANSISTOR	KRC102S	1	2216190R2	NSP
Q9005or	TRANSISTOR	DTC114ECAT116	(1)	2219010R2	NSP
Q9010	TRANSISTOR	KRC105S	1	2217290R2	NSP
Q9010or	TRANSISTOR	DTC123JCAT116	(1)	2219040R2	NSP
Q9032	TRANSISTOR	KRC102S	1	2216190R2	NSP
Q9032or	TRANSISTOR	DTC114ECAT116	(1)	2219010R2	NSP
Q9033	TRANSISTOR	KRA102S	1	2216220R2	NSP
Q9033or	TRANSISTOR	DTA114ECAT116	(1)	2218980R2	NSP
X1	CRYSTAL	HC-49S 9B12.000MHz	1	3010533	
<b>[ Transformers, Coils ]</b>					
L1	CHIP TYPE CARBON RESISTOR	RN72K1J-000JE	1	435030004R1	NSP
L1500	EMI SUPPRESSION FILTER	BK1608HS102-T	1	230955R2	NSP
L1501	CHOKE COIL	LBC2518T470M	1	231364M470R2	NSP
L2	CHIP TYPE CARBON RESISTOR	RN72K1J-000JE	1	435030004R1	NSP
L2501	EMI SUPPRESSION FILTER	BK1608LL241-T	1	230959R1	NSP
L2502	EMI SUPPRESSION FILTER	BK1608LL241-T	1	230959R1	NSP
L3	RF COIL	SDCL1608CR33JTDF	1	233557R1	NSP
L4	RF COIL	SDCL1608CR10JTDF	1	233556R1	NSP
L5	ANTENNA COIL	K7-D	1	232212	
L7761	CORE	BLM18PG181SN1D	1	2350005R1	NSP
L7762	CORE	BLM18PG121SN1D	1	2350006R1	NSP
L7900	CHOKE COIL	LBC2518T2R2M	1	231364M022R2	NSP
L7901	CHOKE COIL	LBC2518T2R2M	1	231364M022R2	NSP
L9001	CHOKE COIL	EM-UT2014-0033	1	231474	
L9002	CHOKE COIL	RCR1010NP-100M	1	231449M100	
T9001	POWER TRANSFORMER	NPT-1632S	1	2302076	!
T9001or	POWER TRANSFORMER	NPT-1633S	(1)	2302077	!
<b>[ Capacitors ]</b>					
C1	CHIP TYPE CERAMIC CAPACITOR	CC725CH1H-101J1	1	342101014R1	NSP
C12	CHIP TYPE CERAMIC CAPACITOR	CC725CH1H-090D1	1	342100902R1	NSP
C13	CHIP TYPE CERAMIC CAPACITOR	CK725B1C-104K1	1	332121045R1	NSP
C1500	CHIP TYPE CERAMIC CAPACITOR	CK725F1E-104Z1	1	332161040R1	NSP
C1502	CHIP TYPE CERAMIC CAPACITOR	CK725B1C-104K1	1	332121045R1	NSP
C1503	CHIP TYPE CERAMIC CAPACITOR	CC725CH1H-080D1	1	342100802R1	NSP
C1504	CHIP TYPE CERAMIC CAPACITOR	CK725F1E-104Z1	1	332161040R1	NSP
C1505	CHIP TYPE CERAMIC CAPACITOR	CK725F1E-104Z1	1	332161040R1	NSP
C1506	UTSP TYPE ELECTROLYTIC CAPACITOR	CE04W10V-220M(UTSP)	1	397532217AT	

C1507	CHIP TYPE CERAMIC CAPACITOR	CK725F1E-104Z1	1	332161040R1	NSP
C1508	UTSP TYPE ELECTROLYTIC CAPACITOR	CE04W25V-100M(UTSP)	1	397551017AT	
C1509	UTSP TYPE ELECTROLYTIC CAPACITOR	CE04W25V-100M(UTSP)	1	397551017AT	
C1510	UMXR TYPE PLASTIC FILM CAPACITOR	1JUMXRTE222JE	1	376592224T	NSP
C1511	UMXR TYPE PLASTIC FILM CAPACITOR	1JUMXRTE222JE	1	376592224T	NSP
C1512	UPZ TYPE PLASTIC FILM CAPACITOR	2AUPZTF471JE	1	376334714T	NSP
C1513	UPZ TYPE PLASTIC FILM CAPACITOR	2AUPZTF471JE	1	376334714T	NSP
C1514	UPZ TYPE PLASTIC FILM CAPACITOR	2AUPZTF101JE	1	376331014T	NSP
C1515	UPZ TYPE PLASTIC FILM CAPACITOR	2AUPZTF101JE	1	376331014T	NSP
C1516	UMXR TYPE PLASTIC FILM CAPACITOR	1JUMXRTE222JE	1	376592224T	NSP
C1517	UMXR TYPE PLASTIC FILM CAPACITOR	1JUMXRTE222JE	1	376592224T	NSP
C1518	UTSP TYPE ELECTROLYTIC CAPACITOR	CE04W25V-47M(UTSP)	1	397554707AT	
C1519	UTSP TYPE ELECTROLYTIC CAPACITOR	CE04W25V-47M(UTSP)	1	397554707AT	
C1520	UTSP TYPE ELECTROLYTIC CAPACITOR	CE04W25V-47M(UTSP)	1	397554707AT	
C1521	UTSP TYPE ELECTROLYTIC CAPACITOR	CE04W25V-47M(UTSP)	1	397554707AT	
C1522	UTSP TYPE ELECTROLYTIC CAPACITOR	CE04W50V-22M(UTSP)	1	397582207AT	
C1523	UTSP TYPE ELECTROLYTIC CAPACITOR	CE04W50V-22M(UTSP)	1	397582207AT	
C1529	UTSP TYPE ELECTROLYTIC CAPACITOR	CE04W50V-22M(UTSP)	1	397582207AT	
C1530	UTSP TYPE ELECTROLYTIC CAPACITOR	CE04W25V-47M(UTSP)	1	397554707AT	
C1531	UTSP TYPE ELECTROLYTIC CAPACITOR	CE04W25V-47M(UTSP)	1	397554707AT	
C2	CHIP TYPE CERAMIC CAPACITOR	CC725CH1H-220J1	1	342102204R1	NSP
C2000	FILM C	C281H334J20A21A	1	376823344T	NSP
C2001	JAMICON TYPE ELECTROLYTIC CAPACIT	CE04W50V-4.7M	1	398580477T	
C2002	ELECTROLYTIC CAPACITOR	CE69W25V-10000M	1	3504512	
C2502	CHIP TYPE CERAMIC CAPACITOR	CK725B1H-822K	1	332248225R1	NSP
C2504	CHIP TYPE CERAMIC CAPACITOR	CK725F1E-104Z1	1	332161040R1	NSP
C2602	CHIP TYPE CERAMIC CAPACITOR	CK725B1H-102K1	1	332101025R1	NSP
C2701	CHIP TYPE CERAMIC CAPACITOR	CK725B1H-102K1	1	332101025R1	NSP
C2801	CHIP TYPE CERAMIC CAPACITOR	CK725B1H-102K1	1	332101025R1	NSP
C3	CHIP TYPE CERAMIC CAPACITOR	CK725B1H-332K1	1	332103325R1	NSP
C4	CHIP TYPE CERAMIC CAPACITOR	CC725CH1H-100D1	1	342101002R1	NSP
C5	CHIP TYPE CERAMIC CAPACITOR	CK725B1H-473K1	1	332104735R1	NSP
C5001	UPZ TYPE PLASTIC FILM CAPACITOR	2AUPZTF221JE	1	376332214T	NSP
C5002	UPZ TYPE PLASTIC FILM CAPACITOR	2AUPZTF221JE	1	376332214T	NSP
C5021	UTSP TYPE ELECTROLYTIC CAPACITOR	CE04W50V 47M(UTSP)	1	397584707AT	
C5022	UTSP TYPE ELECTROLYTIC CAPACITOR	CE04W50V 47M(UTSP)	1	397584707AT	
C5081	UTSP TYPE ELECTROLYTIC CAPACITOR	CE04W50V-10M(UTSP)	1	397581007AT	
C5082	UTSP TYPE ELECTROLYTIC CAPACITOR	CE04W50V-10M(UTSP)	1	397581007AT	
C5481	UPZ TYPE PLASTIC FILM CAPACITOR	2AUPZTF101JE	1	376331014T	NSP
C5482	UPZ TYPE PLASTIC FILM CAPACITOR	2AUPZTF101JE	1	376331014T	NSP
C5501	VR TYPE ELECTROLYTIC CAPACITOR	CE04W100V-22M(VR)	1	394692207T	
C5502	VR TYPE ELECTROLYTIC CAPACITOR	CE04W100V-22M(VR)	1	394692207T	
C5521	VR TYPE ELECTROLYTIC CAPACITOR	CE04W100V-22M(VR)	1	394692207T	
C5522	VR TYPE ELECTROLYTIC CAPACITOR	CE04W100V-22M(VR)	1	394692207T	
C5641	UTSP TYPE ELECTROLYTIC CAPACITOR	CE04W50V 47M(UTSP)	1	397584707AT	
C5642	UTSP TYPE ELECTROLYTIC CAPACITOR	CE04W50V 47M(UTSP)	1	397584707AT	
C6	CHIP TYPE CERAMIC CAPACITOR	CK725B1H-222K1	1	332102225R1	NSP
C6401	CERAMIC CAPACITOR	CC45SL50V-040C	1	345020401T	NSP
C6402	CERAMIC CAPACITOR	CC45SL50V-040C	1	345020401T	NSP
C6421	UTSP TYPE ELECTROLYTIC CAPACITOR	CE04W25V-220M(UTSP)	1	397552217T	
C6422	UTSP TYPE ELECTROLYTIC CAPACITOR	CE04W25V-220M(UTSP)	1	397552217T	
C7	CHIP TYPE CERAMIC CAPACITOR	CK725B1A-105K1	1	332131055R1	NSP
C7500	ELECTROLYTIC CAPACITOR	CE04W16V-10M(S)	1	353741009T	
C7501	CHIP TYPE CERAMIC CAPACITOR	CK725B1H-223K1	1	332102235R1	NSP
C7502	ELECTROLYTIC CAPACITOR	CE04W16V-47M(S)	1	353744709T	

C7503	ELECTROLYTIC CAPACITOR	CE04W16V-47M(S)	1	353744709T	
C7535	CHIP TYPE CERAMIC CAPACITOR	CK732B16V-106K	1	332071065R2	NSP
C7740	CHIP TYPE CERAMIC CAPACITOR	CK725B1H-103K1	1	332101035R1	NSP
C7741	CHIP TYPE CERAMIC CAPACITOR	CK725B1H-103K1	1	332101035R1	NSP
C7744	CHIP TYPE CERAMIC CAPACITOR	CK725B1H-103K1	1	332101035R1	NSP
C7745	CHIP TYPE CERAMIC CAPACITOR	CK725B1H-103K1	1	332101035R1	NSP
C7748	CHIP TYPE CERAMIC CAPACITOR	CK725B1H-103K1	1	332101035R1	NSP
C7749	CHIP TYPE CERAMIC CAPACITOR	CK725B1H-103K1	1	332101035R1	NSP
C7752	CHIP TYPE CERAMIC CAPACITOR	CK725B1H-103K1	1	332101035R1	NSP
C7753	CHIP TYPE CERAMIC CAPACITOR	CK725B1H-103K1	1	332101035R1	NSP
C7760	CHIP TYPE CERAMIC CAPACITOR	CC725CH1H-102J1	1	342101024R1	NSP
C7762	CHIP TYPE CERAMIC CAPACITOR	CC725CH1H-102J1	1	342101024R1	NSP
C7764	CHIP TYPE CERAMIC CAPACITOR	CC725CH1H-102J1	1	342101024R1	NSP
C7770	CHIP TYPE CERAMIC CAPACITOR	CK725B1H-103K1	1	332101035R1	NSP
C7771	CHIP TYPE CERAMIC CAPACITOR	CK725B1H-103K1	1	332101035R1	NSP
C7780	ELECTROLYTIC CAPACITOR	CE04W6.3V-100M(S)	1	353721019T	
C7781	CHIP TYPE CERAMIC CAPACITOR	CC725CH1H-102J1	1	342101024R1	NSP
C7880	CHIP TYPE CERAMIC CAPACITOR	CK725B1H-103K1	1	332101035R1	NSP
C7881	UPZ TYPE PLASTIC FILM CAPACITOR	2AUPZTF221JE	1	376332214T	NSP
C7882	UPZ TYPE PLASTIC FILM CAPACITOR	2AUPZTF221JE	1	376332214T	NSP
C7883	CHIP TYPE CERAMIC CAPACITOR	CC725CH1H-102J1	1	342101024R1	NSP
C7884	CHIP TYPE CERAMIC CAPACITOR	CC725CH1H-102J1	1	342101024R1	NSP
C7900	ELECTROLYTIC CAPACITOR	CE04W50V-33M	1	355783309T	
C7901	JAMICON TYPE ELECTROLYTIC CAPACITC	CE04W50V-47M	1	398584707T	
C7902	JAMICON TYPE ELECTROLYTIC CAPACITC	CE04W50V-47M	1	398584707T	
C7903	CHIP TYPE CERAMIC CAPACITOR	CK725B1H-223K1	1	332102235R1	NSP
C7904	CHIP TYPE CERAMIC CAPACITOR	CK725B1H-223K1	1	332102235R1	NSP
C7905	ELECTROLYTIC CAPACITOR	CE04W35V-47M	1	355764709T	
C7907	CHIP TYPE CERAMIC CAPACITOR	CK725B1H-223K1	1	332102235R1	NSP
C7908	CHIP TYPE CERAMIC CAPACITOR	CK725B1H-473K1	1	332104735R1	NSP
C7909	CHIP TYPE CERAMIC CAPACITOR	CK725F1H-104Z1	1	332151040R1	NSP
C7910	CHIP TYPE CERAMIC CAPACITOR	CC725CH1H-101J1	1	342101014R1	NSP
C7911	CHIP TYPE CERAMIC CAPACITOR	CC725CH1H-101J1	1	342101014R1	NSP
C7912	CHIP TYPE CERAMIC CAPACITOR	CC725CH1H-101J1	1	342101014R1	NSP
C7913	CHIP TYPE CERAMIC CAPACITOR	CC725CH1H-101J1	1	342101014R1	NSP
C7914	CHIP TYPE CERAMIC CAPACITOR	CK725F1E-104Z1	1	332161040R1	NSP
C7915	CHIP TYPE CERAMIC CAPACITOR	CK725B1H-223K1	1	332102235R1	NSP
C7916	CHIP TYPE CERAMIC CAPACITOR	CK725B1H-223K1	1	332102235R1	NSP
C7917	ELECTROLYTIC CAPACITOR	CE04W50V-33M	1	355783309T	
C8	CHIP TYPE CERAMIC CAPACITOR	CK725B1A-105K1	1	332131055R1	NSP
C9	CHIP TYPE CERAMIC CAPACITOR	CK732B16V-106K	1	332071065R2	NSP
C9001	IS TYPE CAPACITOR	LE104-MX-C3.5	1	3800049S	!
C9002	ELECTROLYTIC CAPACITOR	CE04W200V-100M(KXJ)	1	3500233S	
C9003	PW TYPE ELECTROLYTIC CAPACITOR	CE04W50V-10M(PW)	1	393781007T	
C9004	PW TYPE ELECTROLYTIC CAPACITOR	CE04W25V-1000M(PW)	1	393751027S	
C9006	PW TYPE ELECTROLYTIC CAPACITOR	CE04W25V-470M(PW)	1	393754717T	
C9009	CHIP TYPE CERAMIC CAPACITOR	GRM31A7U3D220JW31D	1	3300071R1	NSP
C9010	IS TYPE CAPACITOR	DE1E3KX102MJ4BN01F	1	3300100S	!
C9011	CHIP TYPE CERAMIC CAPACITOR	CK725B1C-104K1	1	332121045R1	NSP
C9012	IS TYPE CAPACITOR	LE103-C3.5	1	3800042S	!
C9013	UTSP TYPE ELECTROLYTIC CAPACITOR	CE04W25V-220M(UTSP)	1	397552217T	
C9014	CHIP TYPE CERAMIC CAPACITOR	CK725B1H-103K1	1	332101035R1	NSP
C9015	CHIP TYPE CERAMIC CAPACITOR	CK725F1E-104Z1	1	332161040R1	NSP
C9016	CHIP TYPE CERAMIC CAPACITOR	CK725B1H-332K1	1	332103325R1	NSP
C9018	IS TYPE CAPACITOR	LE104-MX-C3.5	1	3800049S	!



C9019	IS TYPE CAPACITOR	DE1E3KX102MJ4BN01F	1	3300100S	!
C9023	CHIP TYPE CERAMIC CAPACITOR	CK725F1E-104Z1	1	332161040R1	NSP
C9024	CHIP TYPE CERAMIC CAPACITOR	CK725F1E-104Z1	1	332161040R1	NSP
C9025	IS TYPE CAPACITOR	DE1E3KX102MJ4BN01F	1	3300100S	!
<b>[ Resistors ]</b>					
R10	CHIP TYPE CARBON RESISTOR	RN72K1J-000JE	1	435030004R1	NSP
R11	CHIP TYPE CARBON RESISTOR	RN72K1J-000JE	1	435030004R1	NSP
R13	CHIP TYPE CARBON RESISTOR	RN72K1J-000JE	1	435030004R1	NSP
R14	CHIP TYPE CARBON RESISTOR	RN72K1J-000JE	1	435030004R1	NSP
R1500	CHIP TYPE CARBON RESISTOR	RN72K1J-470JE	1	435034704R1	NSP
R1501	CHIP TYPE CARBON RESISTOR	RN72K1J-750JE	1	435037504R1	NSP
R1502	CHIP TYPE CARBON RESISTOR	RN72K1J-100JE	1	435031004R1	NSP
R1504	CHIP TYPE CARBON RESISTOR	RN72K1J-103JE	1	435031034R1	NSP
R1505	CHIP TYPE CARBON RESISTOR	RN72K1J-823JE	1	435038234R1	NSP
R1506	CHIP TYPE CARBON RESISTOR	RN72K1J-470JE	1	435034704R1	NSP
R1507	CHIP TYPE CARBON RESISTOR	RN72K1J-472JE	1	435034724R1	NSP
R1508	CHIP TYPE CARBON RESISTOR	RN72K1J-472JE	1	435034724R1	NSP
R1509	CHIP TYPE CARBON RESISTOR	RN72K1J-222JE	1	435032224R1	NSP
R1510	CHIP TYPE CARBON RESISTOR	RN72K1J-222JE	1	435032224R1	NSP
R1511	CHIP TYPE CARBON RESISTOR	RN72K1J-472JE	1	435034724R1	NSP
R1512	CHIP TYPE CARBON RESISTOR	RN72K1J-472JE	1	435034724R1	NSP
R1513	CHIP TYPE CARBON RESISTOR	RN72K1J-472JE	1	435034724R1	NSP
R1514	CHIP TYPE CARBON RESISTOR	RN72K1J-472JE	1	435034724R1	NSP
R1515	CHIP TYPE CARBON RESISTOR	RN72K1J-472JE	1	435034724R1	NSP
R1516	CHIP TYPE CARBON RESISTOR	RN72K1J-472JE	1	435034724R1	NSP
R1517	CHIP TYPE CARBON RESISTOR	RN72K1J-681JE	1	435036814R1	NSP
R1518	CHIP TYPE CARBON RESISTOR	RN72K1J-102JE	1	435031024R1	NSP
R1519	CHIP TYPE CARBON RESISTOR	RN72K1J-102JE	1	435031024R1	NSP
R1520	CHIP TYPE CARBON RESISTOR	RN72K1J-152JE	1	435031524R1	NSP
R1521	CHIP TYPE CARBON RESISTOR	RN72K1J-152JE	1	435031524R1	NSP
R1522	CHIP TYPE CARBON RESISTOR	RN72K1J-682JE	1	435036824R1	NSP
R1523	CHIP TYPE CARBON RESISTOR	RN72K1J-682JE	1	435036824R1	NSP
R1524	CHIP TYPE CARBON RESISTOR	RN72K1J-152JE	1	435031524R1	NSP
R1525	CHIP TYPE CARBON RESISTOR	RN72K1J-152JE	1	435031524R1	NSP
R1526	CHIP TYPE CARBON RESISTOR	RN72K1J-220JE	1	435032204R1	NSP
R1527	CHIP TYPE CARBON RESISTOR	RN72K1J-220JE	1	435032204R1	NSP
R1528	CHIP TYPE CARBON RESISTOR	RN72K1J-681JE	1	435036814R1	NSP
R1531	CHIP TYPE CARBON RESISTOR	RN72K1J-224JE	1	435032244R1	NSP
R1532	CHIP TYPE CARBON RESISTOR	RN72K1J-224JE	1	435032244R1	NSP
R1533	CHIP TYPE CARBON RESISTOR	RN72K1J-224JE	1	435032244R1	NSP
R1534	CHIP TYPE CARBON RESISTOR	RN72K1J-224JE	1	435032244R1	NSP
R1535	CHIP TYPE CARBON RESISTOR	RN72K1J-104JE	1	435031044R1	NSP
R1536	CHIP TYPE CARBON RESISTOR	RN72K1J-104JE	1	435031044R1	NSP
R1542	CHIP TYPE CARBON RESISTOR	RN72K1J-223JE	1	435032234R1	NSP
R1543	CHIP TYPE CARBON RESISTOR	RN72K1J-000JE	1	435030004R1	NSP
R1544	CHIP TYPE CARBON RESISTOR	RN72K1J-000JE	1	435030004R1	NSP
R1562	CHIP TYPE CARBON RESISTOR	RN72K1J-000JE	1	435030004R1	NSP
R1563	CHIP TYPE CARBON RESISTOR	RN72K2E-000JE	1	435220004R1	NSP
R1564	CHIP TYPE CARBON RESISTOR	RN72K1J-000JE	1	435030004R1	NSP
R1565	CHIP TYPE CARBON RESISTOR	RN72K2E-000JE	1	435220004R1	NSP
R1566	CHIP TYPE CARBON RESISTOR	RN72K1J-000JE	1	435030004R1	NSP
R1567	CHIP TYPE CARBON RESISTOR	RN72K1J-000JE	1	435030004R1	NSP
R1568	CHIP TYPE CARBON RESISTOR	RN72K1J-000JE	1	435030004R1	NSP
R1569	CHIP TYPE CARBON RESISTOR	RN72K1J-000JE	1	435030004R1	NSP
R1571	CHIP TYPE CARBON RESISTOR	RN72K1J-000JE	1	435030004R1	NSP

R2	CHIP TYPE CARBON RESISTOR	RN72K1J-101JE	1	435031014R1	NSP
R2000	CHIP TYPE CARBON RESISTOR	RN72K1J-103JE	1	435031034R1	NSP
R2001	CHIP TYPE CARBON RESISTOR	RN72K1J-103JE	1	435031034R1	NSP
R21	CHIP TYPE CARBON RESISTOR	RN72K2E-000JE	1	435220004R1	NSP
R22	CHIP TYPE CARBON RESISTOR	RN72K2E-000JE	1	435220004R1	NSP
R2501	CHIP TYPE CARBON RESISTOR	RN72K1J-104JE	1	435031044R1	NSP
R2503	CHIP TYPE CARBON RESISTOR	RN72K1J-562JE	1	435035624R1	NSP
R2505	CHIP TYPE CARBON RESISTOR	RN72K1J-102JE	1	435031024R1	NSP
R2506	CHIP TYPE CARBON RESISTOR	RN72K1J-000JE	1	435030004R1	NSP
R2601	CHIP TYPE CARBON RESISTOR	RN72K1J-331JE	1	435033314R1	NSP
R2602	CHIP TYPE CARBON RESISTOR	RN72K1J-331JE	1	435033314R1	NSP
R2702	CHIP TYPE CARBON RESISTOR	RN72K1J-221JE	1	435032214R1	NSP
R2801	CHIP TYPE CARBON RESISTOR	RN72K1J-333JE	1	435033334R1	NSP
R2802	CHIP TYPE CARBON RESISTOR	RN72K1J-103JE	1	435031034R1	NSP
R2803	CHIP TYPE CARBON RESISTOR	RN72K1J-103JE	1	435031034R1	NSP
R2804	CHIP TYPE CARBON RESISTOR	RN72K1J-103JE	1	435031034R1	NSP
R2805	CHIP TYPE CARBON RESISTOR	RN72K1J-180JE	1	435031804R1	NSP
R2806	CHIP TYPE CARBON RESISTOR	RN72K1J-180JE	1	435031804R1	NSP
R2807	CHIP TYPE CARBON RESISTOR	RN72K1J-180JE	1	435031804R1	NSP
R2808	CHIP TYPE CARBON RESISTOR	RN72K1J-180JE	1	435031804R1	NSP
R2809	CHIP TYPE CARBON RESISTOR	RN72K1J-333JE	1	435033334R1	NSP
R2810	CHIP TYPE CARBON RESISTOR	RN72K1J-103JE	1	435031034R1	NSP
R2811	CHIP TYPE CARBON RESISTOR	RN72K1J-103JE	1	435031034R1	NSP
R2812	CHIP TYPE CARBON RESISTOR	RN72K1J-103JE	1	435031034R1	NSP
R2813	CHIP TYPE CARBON RESISTOR	RN72K1J-180JE	1	435031804R1	NSP
R2814	CHIP TYPE CARBON RESISTOR	RN72K1J-103JE	1	435031034R1	NSP
R2815	CHIP TYPE CARBON RESISTOR	RN72K1J-103JE	1	435031034R1	NSP
R3	EMI SUPPRESSION FILTER	BK1608HS601-T	1	230984R1	NSP
R4	EMI SUPPRESSION FILTER	BK1608HS601-T	1	230984R1	NSP
R5	CHIP TYPE CARBON RESISTOR	RN72K1J-103JE	1	435031034R1	NSP
R5001	CHIP TYPE CARBON RESISTOR	RN72K1J-152JE	1	435031524R1	NSP
R5002	CHIP TYPE CARBON RESISTOR	RN72K1J-152JE	1	435031524R1	NSP
R5021	CHIP TYPE CARBON RESISTOR	RN72K1J-563JE	1	435035634R1	NSP
R5022	CHIP TYPE CARBON RESISTOR	RN72K1J-563JE	1	435035634R1	NSP
R5041	CHIP TYPE CARBON RESISTOR	RN72K1J-331JE	1	435033314R1	NSP
R5042	CHIP TYPE CARBON RESISTOR	RN72K1J-331JE	1	435033314R1	NSP
R5061	METAL OXIDE FILM RESISTOR	RS1/2WBJ-100K	1	443521044T	NSP
R5062	METAL OXIDE FILM RESISTOR	RS1/2WBJ-100K	1	443521044T	NSP
R5081	CHIP TYPE CARBON RESISTOR	RN72K1J-104JE	1	435031044R1	NSP
R5082	CHIP TYPE CARBON RESISTOR	RN72K1J-104JE	1	435031044R1	NSP
R5101	CHIP TYPE CARBON RESISTOR	RN72K1J-152JE	1	435031524R1	NSP
R5102	CHIP TYPE CARBON RESISTOR	RN72K1J-152JE	1	435031524R1	NSP
R5181	CHIP TYPE CARBON RESISTOR	RN72K1J-100JE	1	435031004R1	NSP
R5182	CHIP TYPE CARBON RESISTOR	RN72K1J-100JE	1	435031004R1	NSP
R5201	CHIP TYPE CARBON RESISTOR	RN72K1J-100JE	1	435031004R1	NSP
R5202	CHIP TYPE CARBON RESISTOR	RN72K1J-100JE	1	435031004R1	NSP
R5221	CHIP TYPE CARBON RESISTOR	RN72K1J-562JE	1	435035624R1	NSP
R5222	CHIP TYPE CARBON RESISTOR	RN72K1J-562JE	1	435035624R1	NSP
R5241	CHIP TYPE CARBON RESISTOR	RN72K1J-182JE	1	435031824R1	NSP
R5242	CHIP TYPE CARBON RESISTOR	RN72K1J-182JE	1	435031824R1	NSP
R5301	CHIP TYPE CARBON RESISTOR	RN72K1J-152JE	1	435031524R1	NSP
R5302	CHIP TYPE CARBON RESISTOR	RN72K1J-152JE	1	435031524R1	NSP
R5321	CHIP TYPE CARBON RESISTOR	RN72K1J-152JE	1	435031524R1	NSP
R5322	CHIP TYPE CARBON RESISTOR	RN72K1J-152JE	1	435031524R1	NSP
R5381	NON-FLAMMABLE CARBON FILM RESISTO	R25J-220	1	415472214T	

R5382	NON-FLAMMABLE CARBON FILM RESISTO R25J-220		1	415472214T	
R5401	NON-FLAMMABLE CARBON FILM RESISTO R25J-220		1	415472214T	
R5402	NON-FLAMMABLE CARBON FILM RESISTO R25J-220		1	415472214T	
R5421	NON-FLAMMABLE CARBON FILM RESISTO R25J-220		1	415472214T	
R5422	NON-FLAMMABLE CARBON FILM RESISTO R25J-220		1	415472214T	
R5441	NON-FLAMMABLE CARBON FILM RESISTO R25J-220		1	415472214T	
R5442	NON-FLAMMABLE CARBON FILM RESISTO R25J-220		1	415472214T	
R5461	NON-FLAMMABLE CARBON FILM RESISTO R25J-33K		1	415473334T	
R5462	NON-FLAMMABLE CARBON FILM RESISTO R25J-33K		1	415473334T	
R5481	NON-FLAMMABLE CARBON FILM RESISTO R25J-33K		1	415473334T	
R5482	NON-FLAMMABLE CARBON FILM RESISTO R25J-33K		1	415473334T	
R5501	NON-FLAMMABLE CARBON FILM RESISTO R25J-10		1	415471004T	
R5502	NON-FLAMMABLE CARBON FILM RESISTO R25J-10		1	415471004T	
R5521	NON-FLAMMABLE CARBON FILM RESISTO R25J-10		1	415471004T	
R5522	NON-FLAMMABLE CARBON FILM RESISTO R25J-10		1	415471004T	
R5781	CHIP TYPE CARBON RESISTOR	RN72K1J-223FE	1	435032232R1	NSP
R5782	CHIP TYPE CARBON RESISTOR	RN72K1J-223FE	1	435032232R1	NSP
R6	CHIP TYPE CARBON RESISTOR	RN72K1J-222JE	1	435032224R1	NSP
R6401	NON-FLAMMABLE CARBON FILM RESISTO R25J-56K		1	415475634T	
R6402	NON-FLAMMABLE CARBON FILM RESISTO R25J-56K		1	415475634T	
R6421	CHIP TYPE CARBON RESISTOR	RN72K1J-182JE	1	435031824R1	NSP
R6422	CHIP TYPE CARBON RESISTOR	RN72K1J-182JE	1	435031824R1	NSP
R7	CHIP TYPE CARBON RESISTOR	RN72K1J-222JE	1	435032224R1	NSP
R7502	CHIP TYPE CARBON RESISTOR	RN72K1J-221JE	1	435032214R1	NSP
R7515	CHIP TYPE CARBON RESISTOR	RN72K1J-393JE	1	435033934R1	NSP
R7601	CHIP TYPE CARBON RESISTOR	RN72K1J-271JE	1	435032714R1	NSP
R7602	CHIP TYPE CARBON RESISTOR	RN72K1J-331JE	1	435033314R1	NSP
R7603	CHIP TYPE CARBON RESISTOR	RN72K1J-471JE	1	435034714R1	NSP
R7604	CHIP TYPE CARBON RESISTOR	RN72K1J-561JE	1	435035614R1	NSP
R7605	CHIP TYPE CARBON RESISTOR	RN72K1J-821JE	1	435038214R1	NSP
R7606	CHIP TYPE CARBON RESISTOR	RN72K1J-122JE	1	435031224R1	NSP
R7607	CHIP TYPE CARBON RESISTOR	RN72K1J-222JE	1	435032224R1	NSP
R7608	CHIP TYPE CARBON RESISTOR	RN72K1J-392JE	1	435033924R1	NSP
R7611	CHIP TYPE CARBON RESISTOR	RN72K1J-271JE	1	435032714R1	NSP
R7612	CHIP TYPE CARBON RESISTOR	RN72K1J-331JE	1	435033314R1	NSP
R7613	CHIP TYPE CARBON RESISTOR	RN72K1J-471JE	1	435034714R1	NSP
R7614	CHIP TYPE CARBON RESISTOR	RN72K1J-561JE	1	435035614R1	NSP
R7615	CHIP TYPE CARBON RESISTOR	RN72K1J-821JE	1	435038214R1	NSP
R7616	CHIP TYPE CARBON RESISTOR	RN72K1J-122JE	1	435031224R1	NSP
R7617	CHIP TYPE CARBON RESISTOR	RN72K1J-222JE	1	435032224R1	NSP
R7618	CHIP TYPE CARBON RESISTOR	RN72K1J-392JE	1	435033924R1	NSP
R7619	CHIP TYPE CARBON RESISTOR	RN72K1J-123JE	1	435031234R1	NSP
R7740	CHIP TYPE CARBON RESISTOR	RN72K1J-103JE	1	435031034R1	NSP
R7741	CHIP TYPE CARBON RESISTOR	RN72K1J-103JE	1	435031034R1	NSP
R7742	CHIP TYPE CARBON RESISTOR	RN72K1J-103JE	1	435031034R1	NSP
R7743	CHIP TYPE CARBON RESISTOR	RN72K1J-103JE	1	435031034R1	NSP
R7744	CHIP TYPE CARBON RESISTOR	RN72K1J-103JE	1	435031034R1	NSP
R7745	CHIP TYPE CARBON RESISTOR	RN72K1J-103JE	1	435031034R1	NSP
R7746	CHIP TYPE CARBON RESISTOR	RN72K1J-103JE	1	435031034R1	NSP
R7747	CHIP TYPE CARBON RESISTOR	RN72K1J-103JE	1	435031034R1	NSP
R7748	CHIP TYPE CARBON RESISTOR	RN72K1J-103JE	1	435031034R1	NSP
R7749	CHIP TYPE CARBON RESISTOR	RN72K1J-103JE	1	435031034R1	NSP
R7750	CHIP TYPE CARBON RESISTOR	RN72K1J-102JE	1	435031024R1	NSP
R7752	CHIP TYPE CARBON RESISTOR	RN72K1J-103JE	1	435031034R1	NSP
R7753	CHIP TYPE CARBON RESISTOR	RN72K1J-103JE	1	435031034R1	NSP



R7760	CHIP TYPE CARBON RESISTOR	RN72K1J-103JE	1	435031034R1	NSP
R7761	CHIP TYPE CARBON RESISTOR	RN72K1J-103JE	1	435031034R1	NSP
R7764	CHIP TYPE CARBON RESISTOR	RN72K1J-103JE	1	435031034R1	NSP
R7765	CHIP TYPE CARBON RESISTOR	RN72K1J-103JE	1	435031034R1	NSP
R7770	CHIP TYPE CARBON RESISTOR	RN72K1J-103JE	1	435031034R1	NSP
R7771	CHIP TYPE CARBON RESISTOR	RN72K1J-103JE	1	435031034R1	NSP
R7772	CHIP TYPE CARBON RESISTOR	RN72K1J-103JE	1	435031034R1	NSP
R7773	CHIP TYPE CARBON RESISTOR	RN72K1J-103JE	1	435031034R1	NSP
R7780	CHIP TYPE CARBON RESISTOR	RN72K1J-101JE	1	435031014R1	NSP
R7781	CHIP TYPE CARBON RESISTOR	RN72K1J-222JE	1	435032224R1	NSP
R7880	METAL OXIDE FILM RESISTOR	RS1/2WBJ-330	1	443523314T	NSP
R7881	METAL OXIDE FILM RESISTOR	RS1/2WBJ-330	1	443523314T	NSP
R7900	METAL RESISTOR	RNU1/2WCJ-8.2	1	453530824T	NSP
R7901	CHIP TYPE CARBON RESISTOR	RN72K1J-272JE	1	435032724R1	NSP
R7902	CHIP TYPE CARBON RESISTOR	RN72K1J-272JE	1	435032724R1	NSP
R7903	CHIP TYPE CARBON RESISTOR	RN72K1J-010JE	1	435030104R1	NSP
R7904	CHIP TYPE CARBON RESISTOR	RN72K1J-333JE	1	435033334R1	NSP
R7905	CHIP TYPE CARBON RESISTOR	RN72K1J-221JE	1	435032214R1	NSP
R7906	CHIP TYPE CARBON RESISTOR	RN72K1J-473JE	1	435034734R1	NSP
R7907	CHIP TYPE CARBON RESISTOR	RN72K1J-103JE	1	435031034R1	NSP
R7908	CHIP TYPE CARBON RESISTOR	RN72K1J-103JE	1	435031034R1	NSP
R7909	CHIP TYPE CARBON RESISTOR	RN72K1J-224JE	1	435032244R1	NSP
R7910	NON-FLAMMABLE CARBON FILM RESISTOR	R25J-10	1	415471004T	
R7911	CHIP TYPE CARBON RESISTOR	RN72K1J-393JE	1	435033934R1	NSP
R7912	CHIP TYPE CARBON RESISTOR	RN72K1J-104JE	1	435031044R1	NSP
R7913	CHIP TYPE CARBON RESISTOR	RN72K1J-101JE	1	435031014R1	NSP
R7914	NON-FLAMMABLE CARBON FILM RESISTOR	R25J-10	1	415471004T	
R7916	CHIP TYPE CARBON RESISTOR	RN72K1J-104JE	1	435031044R1	NSP
R7917	CHIP TYPE CARBON RESISTOR	RN72K1J-101JE	1	435031014R1	NSP
R7918	CHIP TYPE CARBON RESISTOR	RN72K1J-393JE	1	435033934R1	NSP
R7919	CHIP TYPE CARBON RESISTOR	RN72K1J-221JE	1	435032214R1	NSP
R7920	CHIP TYPE CARBON RESISTOR	RN72K1J-221JE	1	435032214R1	NSP
R7921	CHIP TYPE CARBON RESISTOR	RN72K1J-221JE	1	435032214R1	NSP
R7922	CHIP TYPE CARBON RESISTOR	RN72K1J-332JE	1	435033324R1	NSP
R7923	CHIP TYPE CARBON RESISTOR	RN72K1J-332JE	1	435033324R1	NSP
R7924	CHIP TYPE CARBON RESISTOR	RN72K1J-000JE	1	435030004R1	NSP
R8	CHIP TYPE CARBON RESISTOR	RN72K1J-101JE	1	435031014R1	NSP
R9	CHIP TYPE CARBON RESISTOR	RN72K1J-101JE	1	435031014R1	NSP
R9006	CHIP TYPE CARBON RESISTOR	RN72K1J-392JE	1	435033924R1	NSP
R9007	CHIP TYPE CARBON RESISTOR	RN72K1J-273FE	1	435032732R1	NSP
R9008	CHIP TYPE CARBON RESISTOR	RN72K1J-822JE	1	435038224R1	NSP
R9009	CHIP TYPE CARBON RESISTOR	RN72K1J-103JE	1	435031034R1	NSP
R9010	METAL OXIDE FILM RESISTOR	RS1/2WBJ-68	1	443526804T	NSP
R9011	NON-FLAMMABLE CARBON FILM RESISTOR	R25J-22	1	415472204T	
R9014	METAL RESISTOR	RNU1WCJ-1	1	453630104T	NSP
R9015	METAL OXIDE FILM RESISTOR	RS1/2WBJ-220	1	443522214T	NSP
R9017	CHIP TYPE CARBON RESISTOR	RN72K1J-332JE	1	435033324R1	NSP
R9018	CHIP TYPE CARBON RESISTOR	RN72K1J-182JE	1	435031824R1	NSP
R9022	CHIP TYPE CARBON RESISTOR	RN72K1J-152JE	1	435031524R1	NSP
R9023	CHIP TYPE CARBON RESISTOR	KTR18EZPF6803	1	435236842R1	NSP
R9024	CHIP TYPE CARBON RESISTOR	KTR18EZPF6803	1	435236842R1	NSP
R9025	CHIP TYPE CARBON RESISTOR	KTR18EZPF6803	1	435236842R1	NSP
R9031	METAL OXIDE FILM RESISTOR	RS1/2WBJ-47	1	443524704T	NSP
R9057	CHIP TYPE CARBON RESISTOR	RN72K1J-332JE	1	435033324R1	NSP
R9058	CHIP TYPE CARBON RESISTOR	RN72K1J-332JE	1	435033324R1	NSP

## [ Switches, Terminals, Wires ]

F2000	FUSE	T4A-SEUL-T250V	1	252392T	!
F9001	FUSE	T1A-SEUL-T250V	1	252397T	!
F9002C	FUSE HOLDER	NSCT-1P2031	1	25052133T	! NSP
F9002D	FUSE HOLDER	NSCT-1P2031	1	25052133T	! NSP
P070	PRINTED WIRING BOARD	BCDIS-2394	1	25142394A	N NSP
P070A	PRINTED WIRING BOARD	BCDIS-2394	{1}	25142394	NSP
P070B	PRINTED WIRING BOARD	BCSW-2395	{1}	25142395	N NSP
P070C	PRINTED WIRING BOARD	BCSW-2396	{1}	25142396	N NSP
P070E	PRINTED WIRING BOARD	BCCLA-2398	{1}	25142398	N NSP
P070F	PRINTED WIRING BOARD	BCPS-2399	{1}	25142399	N NSP
P070G	PRINTED WIRING BOARD	BCPS-2400	{1}	25142400	N NSP
P070H	PRINTED WIRING BOARD	BCDG-2401	{1}	25142401	N NSP
P070I	PRINTED WIRING BOARD	BCRF-2402	{1}	25142402	N NSP
P070J	PRINTED WIRING BOARD	BCETC-2403	{1}	25142403	N NSP
P070K	PRINTED WIRING BOARD	BCETC-2404	{1}	25142404	N NSP
P070M	PRINTED WIRING BOARD	BCETC-2408	{1}	25142408	N NSP
P1	TERMINAL	NTM-1PDSC437	1	25060515	
P101A	SOCKET	NSCT-7P2100	1	25052203	NSP
P101B	SOCKET	NSCT-7P2100	1	25052203	NSP
P1500	PIN JACK	NPJ-1PDO585	1	25045805	
P1501A	PLUG	IMSA-9142B-22A	1	25056601	NSP
P1502	TRM(SCREW)	TER21-0130V	1	25060533	NSP
P2	TERMINAL	NTM-2PDML439	1	25060517	
P2000	PLUG	NPLG-3P117	1	25055133	NSP
P2001	WIRE HARNESS ASSEMBLY	NSAS-7P2126	1	2009991315UL	NSP
P2001A	WIRE HOL	CHD-1.5-7	1	25053537	NSP
P2002A	WIRE HOL	CHD-1.5-3	1	25053535	NSP
P2002B	WIRE HOL	CHD-1.5-3	1	25053535	NSP
P2500B	SOCKET	NSCT-9P2400	1	25052503	NSP
P2501	ST JACK	MSJ-035-52E-B-AG-PBT	1	25045947	
P2601	SOCKET	MDS-09P-V-01(DSUB9P)	1	25053363	NSP
P2701	ST JACK	MSJ-035-22	1	25045887	
P2801	ST JACK	MSJ-035-52E-B-AG-PBT	1	25045947	
P3652B	PLUG	NPLG-5P352	1	25055369	NSP
P5509B	RETAINER	(CLA-L)	1	27142312	NSP
P6001A	SOCKET	NSCT-9P2189	1	25052292	NSP
P6002A	SOCKET	NSCT-9P2189	1	25052292	NSP
P7001B	SOCKET	9615S-31C-PP	1	25053319	NSP
P7651A	WIRE HOL	CHD-1.5-5	1	25053536	NSP
P7651B	WIRE HOL	CHD-1.5-5	1	25053536	NSP
P7652A	WIRE HOL	CHD-1.5-5	1	25053536	NSP
P7652B	WIRE HOL	CHD-1.5-5	1	25053536	NSP
P7760	PLUG	UJA02DXA_91-72T	1	25056790	N NSP
P7760or	SOCKET	000010211-00027	(1)	25053411	NSP
P7761	RETAINER	(USB)(404)	1	27142282	NSP
P7880A	PLUG	NPLG-5P119	1	25055135	NSP
P7881	ST JACK	MSJ-064-05A GR	1	25045782	
P7882	TRM(SCREW)	TER21-0130V	1	25060533	NSP
P7900	PLUG	NPLG-5P220	1	25055236	NSP
P8002B	SOCKET	IMSA-9850S-30	1	25053215	NSP
P9001A	PLUG	NPLG-2P631	1	25055675	NSP
P9002	PLUG	NPLG-2P631	1	25055675	NSP
P9011A	PLUG	NPLG-5P0960	1	25056010	NSP
P9011B	SOCKET	NSCT-5P2185	1	25052288	NSP

RL9001	RELAY	NRL-1P10A-DC9-188	1	25065693	!
S7601B	PUSH SWITCH	NPS-111-S681	1	25035718T	NSP
S7601Bor	PUSH SWITCH	NPS-111-S677	(1)	25035714T	NSP
S7602	PUSH SWITCH	NPS-111-S681	1	25035718T	NSP
S7602or	PUSH SWITCH	NPS-111-S677	(1)	25035714T	NSP
S7603	PUSH SWITCH	NPS-111-S681	1	25035718T	NSP
S7603or	PUSH SWITCH	NPS-111-S677	(1)	25035714T	NSP
S7604	PUSH SWITCH	NPS-111-S681	1	25035718T	NSP
S7604or	PUSH SWITCH	NPS-111-S677	(1)	25035714T	NSP
S7605	PUSH SWITCH	NPS-111-S681	1	25035718T	NSP
S7605or	PUSH SWITCH	NPS-111-S677	(1)	25035714T	NSP
S7606	PUSH SWITCH	NPS-111-S681	1	25035718T	NSP
S7606or	PUSH SWITCH	NPS-111-S677	(1)	25035714T	NSP
S7607	PUSH SWITCH	NPS-111-S681	1	25035718T	NSP
S7607or	PUSH SWITCH	NPS-111-S677	(1)	25035714T	NSP
S7608	PUSH SWITCH	NPS-111-S681	1	25035718T	NSP
S7608or	PUSH SWITCH	NPS-111-S677	(1)	25035714T	NSP
S7609	PUSH SWITCH	NPS-111-S681	1	25035718T	NSP
S7609or	PUSH SWITCH	NPS-111-S677	(1)	25035714T	NSP
S7611	PUSH SWITCH	NPS-111-S681	1	25035718T	NSP
S7611or	PUSH SWITCH	NPS-111-S677	(1)	25035714T	NSP
S7612	PUSH SWITCH	NPS-111-S681	1	25035718T	NSP
S7612or	PUSH SWITCH	NPS-111-S677	(1)	25035714T	NSP
S7613	PUSH SWITCH	NPS-111-S681	1	25035718T	NSP
S7613or	PUSH SWITCH	NPS-111-S677	(1)	25035714T	NSP
S7614	PUSH SWITCH	NPS-111-S681	1	25035718T	NSP
S7614or	PUSH SWITCH	NPS-111-S677	(1)	25035714T	NSP
S7615	PUSH SWITCH	NPS-111-S681	1	25035718T	NSP
S7615or	PUSH SWITCH	NPS-111-S677	(1)	25035714T	NSP
S7616	PUSH SWITCH	NPS-111-S681	1	25035718T	NSP
S7616or	PUSH SWITCH	NPS-111-S677	(1)	25035714T	NSP
S7617	PUSH SWITCH	NPS-111-S681	1	25035718T	NSP
S7617or	PUSH SWITCH	NPS-111-S677	(1)	25035714T	NSP
S7618	PUSH SWITCH	NPS-111-S681	1	25035718T	NSP
S7618or	PUSH SWITCH	NPS-111-S677	(1)	25035714T	NSP
S7620B	PUSH SWITCH	NPS-111-S681	1	25035718T	NSP
S7620Bor	PUSH SWITCH	NPS-111-S677	(1)	25035714T	NSP
S7651	ROTARY ENCODER	XREB125PVB25FINB1-2-24PC	1	25065736	
S7651or	ROTARY ENCODER	EVEHC1F2524B	(1)	25065696W	
S7652	ROTARY ENCODER	XREB125PVB25FINB1-2-24PC	1	25065736	
S7652or	ROTARY ENCODER	EVEHC1F2524B	(1)	25065696W	
S7661	ROTARY ENCODER	XREB125PVB25FINB1-2-24PC	1	25065736	
S7661or	ROTARY ENCODER	EVEHC1F2524B	(1)	25065696W	
S7662	ROTARY ENCODER	XREB125PVB25FINB1-2-24PC	1	25065736	
S7662or	ROTARY ENCODER	EVEHC1F2524B	(1)	25065696W	
S7700	ROTARY ENCODER	XREB125(9X11.5)PVB30FINB1	1	25065737	
S7700or	ROTARY ENCODER	EVEHD1F3024B	(1)	25065695W	

**BAPRC-2387-1L****<Note>**

1. Parts marked by "NSP" are generally unavailable because they are not in our Master Spare Parts List.
2. The ! mark found on some component parts indicates the importance of the safety factor of the part.

Therefore, when replacing, be sure to use parts of identical designation.

: NSP

REF. NO.	PART NAME	DESCRIPTION	Q'TY	PART NO. (SN)	REMARKS
<b>[ Semi-conductors ]</b>					
D3000	CHIP TYPE DIODE	DA2J10100	1	223303R2	NSP
D3000or	CHIP TYPE DIODE	1SS352	(1)	223234R2	NSP
D3001	CHIP TYPE DIODE	DA2J10100	1	223303R2	NSP
D3001or	CHIP TYPE DIODE	1SS352	(1)	223234R2	NSP
D3002	CHIP TYPE DIODE	DA2J10100	1	223303R2	NSP
D3002or	CHIP TYPE DIODE	1SS352	(1)	223234R2	NSP
D3003	CHIP TYPE DIODE	DA2J10100	1	223303R2	NSP
D3003or	CHIP TYPE DIODE	1SS352	(1)	223234R2	NSP
D7001	CHIP TYPE DIODE	DA2J10100	1	223303R2	NSP
D7001or	CHIP TYPE DIODE	1SS352	(1)	223234R2	NSP
D7002	CHIP TYPE DIODE	DA2J10100	1	223303R2	NSP
D7002or	CHIP TYPE DIODE	1SS352	(1)	223234R2	NSP
D7003	CHIP TYPE DIODE	DA2J10100	1	223303R2	NSP
D7003or	CHIP TYPE DIODE	1SS352	(1)	223234R2	NSP
D7004	CHIP TYPE DIODE	DA2J10100	1	223303R2	NSP
D7004or	CHIP TYPE DIODE	1SS352	(1)	223234R2	NSP
D7006	DIODE	CUS357	1	223320R2	NSP
D7009	CHIP TYPE DIODE	DA2J10100	1	223303R2	NSP
D7009or	CHIP TYPE DIODE	1SS352	(1)	223234R2	NSP
D8003	ESD	IMSA-6802-01Y901_1608SIZE	1	4000255AR1	NSP
D8900	DIODE	CUS357	1	223320R2	NSP
D8901	DIODE	CUS357	1	223320R2	NSP
D8902	DIODE	CUS357	1	223320R2	NSP
D8909	DIODE	CUS357	1	223320R2	NSP
D8942	CHIP TYPE DIODE	DA2J10100	1	223303R2	NSP
D8942or	CHIP TYPE DIODE	1SS352	(1)	223234R2	NSP
D8943	CHIP TYPE DIODE	DA2J10100	1	223303R2	NSP
D8943or	CHIP TYPE DIODE	1SS352	(1)	223234R2	NSP
D8963	DIODE	RBR3MM30ATR	1	22380401R2	NSP
D8968	CHIP TYPE DIODE	DA2J10100	1	223303R2	NSP
D8968or	CHIP TYPE DIODE	1SS352	(1)	223234R2	NSP
D8969	ZENER DIODE	DZ2J062M0L	1	224760620R2	NSP
Q1001	HYBRID IC	TC7SZU04FU	1	22242512R2TO	NSP
Q1002	HYBRID IC	PCM5101APWR	1	22242855R2	NSP
Q1003	HYBRID IC	74VHC157FT	1	22274157ER2TO	NSP
Q1004	HYBRID IC	AK4438VN	1	22243246R2	NSP
Q1005	HYBRID IC	PCM9211PTR	1	22242703R2	NSP
Q1006	HYBRID IC	74VHC157FT	1	22274157ER2TO	NSP
Q1007	HYBRID IC	74VHC4040FT	1	22274040E1R2TO	NSP
Q1008	HYBRID IC	TC7WH241FU(TE12L_F)	1	22242076R2TO	NSP
Q1008or	HYBRID IC	SN74LVC2G241DCTR	(1)	22243275R2	NSP
Q1009	HYBRID IC	74LCX125FT	1	22274125BR2TO	NSP
Q1010	TRANSISTOR	KRC404E	1	2216450R2	NSP
Q1010or	TRANSISTOR	DTC044EEBTL	(1)	2218700R2	NSP
Q1012	HYBRID IC	74VHC157FT	1	22274157ER2TO	NSP
Q1090	HYBRID IC	MM3464A50NRE	1	22243073R2	NSP
Q1091	HYBRID IC	S-1333A33-M5T1U3	1	22242934R2	NSP
Q1098	HYBRID IC	S-1333A33-M5T1U3	1	22242934R2	NSP

Q3201	HYBRID IC	MFI337S3959	1	22242820R2	NSP
Q3400	HYBRID IC	74LCX125FT	1	22274125BR2TO	NSP
Q3401	HYBRID IC	W25Q64FVSSIG	1	22243270R2	NSP
Q3403	HYBRID IC	TC7SZU04FU	1	22242512R2TO	NSP
Q3404	HYBRID IC	CS49844A-CQZ	1	22242926R3	NSP
Q3406	HYBRID IC	W9864G6KH-7	1	22243269R2	NSP
Q3406or	HYBRID IC	M12L64164A-7TG2Y	(1)	22242951R3	NSP
Q3410	TRANSISTOR	KRC402E	1	2218330R2	NSP
Q3410or	TRANSISTOR	DTC014EEBTL	(1)	2218690R2	NSP
Q3601	HYBRID IC	FP6861C-I1AS5CTR	1	22243274R2	NSP
Q3602	HYBRID IC	FP6861C-E1AS5CTR	1	22243273R2	NSP
Q7000	HYBRID IC	74LCX125FT	1	22274125BR2TO	NSP
Q7001	HYBRID IC	M95640-WMN6TP	1	22242643R2	NSP
Q7002	TRANSISTOR	KRA302E	1	2218360R2	NSP
Q7002or	TRANSISTOR	DTA014EEBTL	(1)	2218680R2	NSP
Q7004	TRANSISTOR	KRA302E	1	2218360R2	NSP
Q7004or	TRANSISTOR	DTA014EEBTL	(1)	2218680R2	NSP
Q7005	TRANSISTOR	KRC404E	1	2216450R2	NSP
Q7005or	TRANSISTOR	DTC044EEBTL	(1)	2218700R2	NSP
Q7006	TRANSISTOR	KRC404E	1	2216450R2	NSP
Q7006or	TRANSISTOR	DTC044EEBTL	(1)	2218700R2	NSP
Q7009	HYBRID IC	MPD70F3477AGJA-GAE-G	1	222W0117R3	NSP
Q7012	TRANSISTOR	KRC402E	1	2218330R2	NSP
Q7012or	TRANSISTOR	DTC014EEBTL	(1)	2218690R2	NSP
Q7013	HYBRID IC	TC7WBL3305CFK	1	22242965R2	NSP
Q7014	TRANSISTOR	KRC402E	1	2218330R2	NSP
Q7014or	TRANSISTOR	DTC014EEBTL	(1)	2218690R2	NSP
Q7015	TRANSISTOR	KRA307E	1	2218380R2	NSP
Q7015or	TRANSISTOR	DTA014YEBTL	(1)	2218681R2	NSP
Q7016	TRANSISTOR	2SC2712-GR	1	2213145R2	NSP
Q7017	TRANSISTOR	KRC402E	1	2218330R2	NSP
Q7017or	TRANSISTOR	DTC014EEBTL	(1)	2218690R2	NSP
Q7018	HYBRID IC	S-1333A33-M5T1U3	1	22242934R2	NSP
Q7019	TRANSISTOR	KRA307E	1	2218380R2	NSP
Q7019or	TRANSISTOR	DTA014YEBTL	(1)	2218681R2	NSP
Q7020	HYBRID IC	PST894A270UR	1	22243198R2	NSP
Q7027	HYBRID IC	S-1333A33-M5T1U3	1	22242934R2	NSP
Q7028	HYBRID IC	ICL3221ECVZ	1	22242268R2	NSP
Q8003	HYBRID IC	74LCX125FT	1	22274125BR2TO	NSP
Q8004	TRANSISTOR	2SA1162-GR	1	2214375R2	NSP
Q8005	TRANSISTOR	KRC404E	1	2216450R2	NSP
Q8005or	TRANSISTOR	DTC044EEBTL	(1)	2218700R2	NSP
Q8401	HYBRID IC	MN864787	1	22242944R3	NSP
Q8402	HYBRID IC	W25Q64FVSSIG	1	22243270R2	NSP
Q8402or	HYBRID IC	IS25LP064A-JBLE	(1)	222W0160R2	NSP
Q8701	HYBRID IC	TMPM361F10FG	1	222W0115R3	NSP
Q8702	TRANSISTOR	KRC402E	1	2218330R2	NSP
Q8702or	TRANSISTOR	DTC014EEBTL	(1)	2218690R2	NSP
Q8704	TRANSISTOR	KRA302E	1	2218360R2	NSP
Q8704or	TRANSISTOR	DTA014EEBTL	(1)	2218680R2	NSP
Q8705	TRANSISTOR	KRC402E	1	2218330R2	NSP
Q8705or	TRANSISTOR	DTC014EEBTL	(1)	2218690R2	NSP
Q8709	TRANSISTOR	KRC402E	1	2218330R2	NSP
Q8709or	TRANSISTOR	DTC014EEBTL	(1)	2218690R2	NSP
Q8710	TRANSISTOR	KRC402E	1	2218330R2	NSP

Q8710or	TRANSISTOR	DTC014EEBTL	(1)	2218690R2	NSP
Q8712	TRANSISTOR	KRC402E	1	2218330R2	NSP
Q8712or	TRANSISTOR	DTC014EEBTL	(1)	2218690R2	NSP
Q8713	TRANSISTOR	KRC402E	1	2218330R2	NSP
Q8713or	TRANSISTOR	DTC014EEBTL	(1)	2218690R2	NSP
Q8725	TRANSISTOR	KRC402E	1	2218330R2	NSP
Q8725or	TRANSISTOR	DTC014EEBTL	(1)	2218690R2	NSP
Q8727	TRANSISTOR	KRC402E	1	2218330R2	NSP
Q8727or	TRANSISTOR	DTC014EEBTL	(1)	2218690R2	NSP
Q8729	TRANSISTOR	KRC402E	1	2218330R2	NSP
Q8729or	TRANSISTOR	DTC014EEBTL	(1)	2218690R2	NSP
Q8921	HYBRID IC	FR9888CSPCTR	1	22242839R2	NSP
Q8931	HYBRID IC	FR9888CSPCTR	1	22242839R2	NSP
Q8946	HYBRID IC	TPS22924CZPR	1	22242807R2	NSP
Q8951	HYBRID IC	FR9888CSPCTR	1	22242839R2	NSP
Q8952	TRANSISTOR	2SC2712-GR	1	2213145R2	NSP
Q8961	HYBRID IC	FR9889SPCTR	1	22243033R2	NSP
Q8965	HYBRID IC	MM3464A50NRE	1	22243073R2	NSP
Q8967	HYBRID IC	FP6861C-E1AS5CTR	1	22243273R2	NSP
X1001	CRYSTAL	HC-49S 9C22.5792M	1	3010535R2	NSP
X3401	CRYSTAL	HC-49S 9C24.5760M	1	3010516R2	NSP
X7001	CRYSTAL	CSTCR4M00G53-R0	1	3010536R2	NSP
X8400	CRYSTAL	HC-49S 9C27.0000M	1	3010518R2	NSP
X8701	CERAMIC RESONATOR	CSTCE8M00G55-R0	1	3010416R2	NSP
<b>[ Transformers, Coils ]</b>					
L1000	CORE	BLM15PX181SN1D	1	2350033R1	NSP
L1001	CORE	BLM15PX181SN1D	1	2350033R1	NSP
L1004	CORE	BK1005LL241-T	1	2350032R1	NSP
L1005	CORE	BK1005LL241-T	1	2350032R1	NSP
L1006	CORE	BK1005LL241-T	1	2350032R1	NSP
L1007	CORE	BK1005LL241-T	1	2350032R1	NSP
L1009	CHOKE COIL	LBC2518T4R7M	1	231364M047R2	NSP
L1010	CHOKE COIL	LBC2518T4R7M	1	231364M047R2	NSP
L1011	CHOKE COIL	LBC2518T4R7M	1	231364M047R2	NSP
L1012	CHOKE COIL	LBC2518T4R7M	1	231364M047R2	NSP
L1013	CHOKE COIL	LBC2518T4R7M	1	231364M047R2	NSP
L1018	CORE	BLM15PX181SN1D	1	2350033R1	NSP
L1019	CORE	BLM15PX181SN1D	1	2350033R1	NSP
L3401	CORE	BLM15PX181SN1D	1	2350033R1	NSP
L3402	CORE	BLM15PX181SN1D	1	2350033R1	NSP
L3403	CORE	BK1005LL241-T	1	2350032R1	NSP
L3405	CORE	BLM15PX121SN1D	1	2350034R1	NSP
L3406	CORE	BLM15PX330SN1D	1	2350043R1	NSP
L3407	CORE	BLM15PX121SN1D	1	2350034R1	NSP
L3408	CORE	BLM15PX121SN1D	1	2350034R1	NSP
L3409	CORE	BLM15PX181SN1D	1	2350033R1	NSP
L3411	CORE	BK1005LL241-T	1	2350032R1	NSP
L3601	CORE	BLM15PX121SN1D	1	2350034R1	NSP
L3602	CORE	BLM15PX121SN1D	1	2350034R1	NSP
L3611	CORE	MCF12102G900-T	1	2350041R2	NSP
L3612	CORE	MCF12102G900-T	1	2350041R2	NSP
L7000	CORE	BLM15PX181SN1D	1	2350033R1	NSP
L7003	CORE	BLM15PX181SN1D	1	2350033R1	NSP
L7007	CORE	BLM15PX181SN1D	1	2350033R1	NSP
L7008	CORE	BLM15PX181SN1D	1	2350033R1	NSP



L8001	CORE	EXC24CH900U	1	2350039R2	NSP
L8002	CORE	EXC24CH900U	1	2350039R2	NSP
L8003	CORE	EXC24CH900U	1	2350039R2	NSP
L8004	CORE	EXC24CH900U	1	2350039R2	NSP
L8400	CORE	BLM15PX121SN1D	1	2350034R1	NSP
L8401	CORE	BLM15PX121SN1D	1	2350034R1	NSP
L8402	CORE	BLM15PX121SN1D	1	2350034R1	NSP
L8403	CORE	BLM15PX121SN1D	1	2350034R1	NSP
L8404	CORE	BLM15PX121SN1D	1	2350034R1	NSP
L8405	CORE	BLM15PX121SN1D	1	2350034R1	NSP
L8406	CORE	BLM15PX121SN1D	1	2350034R1	NSP
L8407	CORE	BLM15PX121SN1D	1	2350034R1	NSP
L8408	CORE	BLM15PX121SN1D	1	2350034R1	NSP
L8409	CORE	BLM15PX121SN1D	1	2350034R1	NSP
L8410	CORE	BLM15PX121SN1D	1	2350034R1	NSP
L8411	CORE	BLM15PX121SN1D	1	2350034R1	NSP
L8412	CORE	BLM15PX121SN1D	1	2350034R1	NSP
L8413	CORE	BLM15PX121SN1D	1	2350034R1	NSP
L8414	CORE	BLM15PX181SN1D	1	2350033R1	NSP
L8415	CORE	BLM15PX121SN1D	1	2350034R1	NSP
L8416	CORE	BK1005LL241-T	1	2350032R1	NSP
L8702	CORE	BLM15PX181SN1D	1	2350033R1	NSP
L8921	CHOKE COIL	BLM21PG221SN1	1	230949R2	NSP
L8922	CHOKE COIL	1255AS-100M	1	231482M100R2	NSP
L8923	CHOKE COIL	BLM21PG221SN1	1	230949R2	NSP
L8924	CHOKE COIL	BLM21PG221SN1	1	230949R2	NSP
L8931	CHOKE COIL	BLM21PG221SN1	1	230949R2	NSP
L8932	CHOKE COIL	1255AS-100M	1	231482M100R2	NSP
L8951	CHOKE COIL	BLM21PG221SN1	1	230949R2	NSP
L8952	CHOKE COIL	1255AS-100M	1	231482M100R2	NSP
L8953	CHOKE COIL	BLM21PG221SN1	1	230949R2	NSP
L8954	CHOKE COIL	BLM21PG221SN1	1	230949R2	NSP
L8961	CHOKE COIL	BLM21PG221SN1	1	230949R2	NSP
L8962	CHOKE COIL	1255AS-100M	1	231482M100R2	NSP
<b>[ Capacitors ]</b>					
C1001	CHIP TYPE CERAMIC CAPACITOR	CK725B1C-104K0	1	332011045R1	NSP
C1002	CHIP ELECT C	CECS16V-100M	1	398641017R2	NSP
C1002or	CHIP ELECT C	CEWX16V-100M	(1)	398141017R2	NSP
C1003	CHIP TYPE CERAMIC CAPACITOR	CK725B1C-104K0	1	332011045R1	NSP
C1004	CHIP TYPE CERAMIC CAPACITOR	CK725B1H-104K1	1	332101045R1	NSP
C1005	CHIP ELECT C	CECS16V-100M	1	398641017R2	NSP
C1005or	CHIP ELECT C	CEWX16V-100M	(1)	398141017R2	NSP
C1008	CHIP TYPE CERAMIC CAPACITOR	CC725CH1H-150J0	1	342031504R1	NSP
C1009	CHIP TYPE CERAMIC CAPACITOR	CC725CH1H-180J0	1	342031804R1	NSP
C1010	CHIP TYPE CERAMIC CAPACITOR	CK725B1C-104K0	1	332011045R1	NSP
C1011	CHIP TYPE CERAMIC CAPACITOR	CK725B1C-104K0	1	332011045R1	NSP
C1012	CHIP ELECT C	CECS4V-220M	1	3986G2217R2	NSP
C1012or	CHIP ELECT C	CEWX4V-220M	(1)	3981G2217R2	NSP
C1013	CHIP TYPE CERAMIC CAPACITOR	CK725B1C-104K0	1	332011045R1	NSP
C1014	CHIP TYPE CERAMIC CAPACITOR	CK725B1C-104K0	1	332011045R1	NSP
C1016	CHIP TYPE CERAMIC CAPACITOR	CK725B1H-104K1	1	332101045R1	NSP
C1017	CHIP ELECT C	CECS16V-100M	1	398641017R2	NSP
C1017or	CHIP ELECT C	CEWX16V-100M	(1)	398141017R2	NSP
C1018	CHIP TYPE CERAMIC CAPACITOR	CK725B1C-104K0	1	332011045R1	NSP
C1020	CHIP ELECT C	CECS4V-220M	1	3986G2217R2	NSP

C1020or	CHIP ELECT C	CEWX4V-220M	(1)	3981G2217R2	NSP
C1021	CHIP TYPE CERAMIC CAPACITOR	CK725B1H-472K0	1	332034725R1	NSP
C1022	CHIP ELECT C	CE32W16V-47M(EC-PC)	1	3500238R2	NSP
C1023	CHIP ELECT C	CECS16V-100M	1	398641017R2	NSP
C1023or	CHIP ELECT C	CEWX16V-100M	(1)	398141017R2	NSP
C1025	CHIP TYPE CERAMIC CAPACITOR	CK725B1H-223K0	1	332032235R1	NSP
C1026	CHIP TYPE CERAMIC CAPACITOR	CK725B1E-473K0	1	332024735R1	NSP
C1027	CHIP ELECT C	CECS4V-220M	1	3986G2217R2	NSP
C1027or	CHIP ELECT C	CEWX4V-220M	(1)	3981G2217R2	NSP
C1032	CHIP TYPE CERAMIC CAPACITOR	CK725B1A-225K1	1	332132255R1	NSP
C1033	CHIP TYPE CERAMIC CAPACITOR	CK725B1A-105K0	1	332001055R1	NSP
C1038	CHIP TYPE CERAMIC CAPACITOR	CC725CH1H-331J0	1	342033314R1	NSP
C1051	CHIP TYPE CERAMIC CAPACITOR	CK725B1C-104K0	1	332011045R1	NSP
C1052	CHIP TYPE CERAMIC CAPACITOR	CK725B1C-104K0	1	332011045R1	NSP
C1053	CHIP TYPE CERAMIC CAPACITOR	CK725B1C-104K0	1	332011045R1	NSP
C1054	CHIP TYPE CERAMIC CAPACITOR	CK725B1A-225K1	1	332132255R1	NSP
C1055	CHIP TYPE CERAMIC CAPACITOR	CK725B1A-225K1	1	332132255R1	NSP
C1056	CHIP TYPE CERAMIC CAPACITOR	CK725B1C-104K0	1	332011045R1	NSP
C1057	CHIP TYPE CERAMIC CAPACITOR	CK732B16V-106K	1	332071065R2	NSP
C1058	CHIP TYPE CERAMIC CAPACITOR	CK725B1H-103K0	1	332031035R1	NSP
C1059	CHIP TYPE CERAMIC CAPACITOR	CK725B1H-103K0	1	332031035R1	NSP
C1068	CHIP TYPE CERAMIC CAPACITOR	CK725B1C-104K0	1	332011045R1	NSP
C1069	CHIP TYPE CERAMIC CAPACITOR	CK725B1C-104K0	1	332011045R1	NSP
C1073	CHIP TYPE CERAMIC CAPACITOR	CK725B1C-104K0	1	332011045R1	NSP
C1074	CHIP TYPE CERAMIC CAPACITOR	CK725B1C-104K0	1	332011045R1	NSP
C1075	CHIP TYPE CERAMIC CAPACITOR	CK725B1C-104K0	1	332011045R1	NSP
C1091	CHIP TYPE CERAMIC CAPACITOR	CK725B0J-226M	1	332092267R2	NSP
C1092	CHIP TYPE CERAMIC CAPACITOR	CK732B16V-106K	1	332071065R2	NSP
C1093	CHIP TYPE CERAMIC CAPACITOR	CK732B16V-106K	1	332071065R2	NSP
C1094	CHIP TYPE CERAMIC CAPACITOR	CK732B16V-106K	1	332071065R2	NSP
C1100	CHIP TYPE CERAMIC CAPACITOR	CK732B16V-106K	1	332071065R2	NSP
C1101	CHIP TYPE CERAMIC CAPACITOR	CK732B16V-106K	1	332071065R2	NSP
C1105	CHIP TYPE CERAMIC CAPACITOR	CK725B1C-104K0	1	332011045R1	NSP
C1106	CHIP TYPE CERAMIC CAPACITOR	CK725B1C-104K0	1	332011045R1	NSP
C1119	CHIP TYPE CERAMIC CAPACITOR	CK725B1H-102K0	1	332031025R1	NSP
C3201	CHIP TYPE CERAMIC CAPACITOR	CK725B1C-104K0	1	332011045R1	NSP
C3325	CHIP TYPE CERAMIC CAPACITOR	CK725B1A-105K0	1	332001055R1	NSP
C3400	CHIP TYPE CERAMIC CAPACITOR	CK725B1C-104K0	1	332011045R1	NSP
C3401	CHIP TYPE CERAMIC CAPACITOR	CC725CH1H-331J0	1	342033314R1	NSP
C3402	CHIP TYPE CERAMIC CAPACITOR	CK725B1C-104K0	1	332011045R1	NSP
C3403	CHIP TYPE CERAMIC CAPACITOR	CK725B1C-104K0	1	332011045R1	NSP
C3404	CHIP TYPE CERAMIC CAPACITOR	CK725B1C-104K0	1	332011045R1	NSP
C3405	CHIP TYPE CERAMIC CAPACITOR	CK725B1C-104K0	1	332011045R1	NSP
C3406	CHIP TYPE CERAMIC CAPACITOR	CK725B1A-105K0	1	332001055R1	NSP
C3407	CHIP TYPE CERAMIC CAPACITOR	CK725B1C-104K0	1	332011045R1	NSP
C3408	CHIP TYPE CERAMIC CAPACITOR	CK725B1H-102K0	1	332031025R1	NSP
C3410	CHIP TYPE CERAMIC CAPACITOR	CK725B1C-104K0	1	332011045R1	NSP
C3411	CHIP TYPE CERAMIC CAPACITOR	CK725B1C-104K0	1	332011045R1	NSP
C3412	CHIP TYPE CERAMIC CAPACITOR	CK725B1C-104K0	1	332011045R1	NSP
C3413	CHIP TYPE CERAMIC CAPACITOR	CC725CH1H-150J0	1	342031504R1	NSP
C3414	CHIP TYPE CERAMIC CAPACITOR	CC725CH1H-120J0	1	342031204R1	NSP
C3415	CHIP TYPE CERAMIC CAPACITOR	CK725B1C-104K0	1	332011045R1	NSP
C3416	CHIP TYPE CERAMIC CAPACITOR	CK725B1C-104K0	1	332011045R1	NSP
C3418	CHIP TYPE CERAMIC CAPACITOR	CK725B1C-104K0	1	332011045R1	NSP
C3419	CHIP TYPE CERAMIC CAPACITOR	CK725B1C-104K0	1	332011045R1	NSP





C7020	CHIP TYPE CERAMIC CAPACITOR	CK725B1A-475K1	1	332134755R1	NSP
C7029	CHIP TYPE CERAMIC CAPACITOR	CK732B16V-106K	1	332071065R2	NSP
C7030	CHIP TYPE CERAMIC CAPACITOR	CK725B1H-102K0	1	332031025R1	NSP
C7031	CHIP TYPE CERAMIC CAPACITOR	CK725B1H-102K0	1	332031025R1	NSP
C7032	CHIP TYPE CERAMIC CAPACITOR	CK725B1C-104K0	1	332011045R1	NSP
C7036	CHIP TYPE CERAMIC CAPACITOR	CK725B1C-104K0	1	332011045R1	NSP
C7038	CHIP TYPE CERAMIC CAPACITOR	CK732B16V-106K	1	332071065R2	NSP
C7039	CHIP TYPE CERAMIC CAPACITOR	CK732B16V-106K	1	332071065R2	NSP
C7052	CHIP TYPE CERAMIC CAPACITOR	CK725B1H-102K0	1	332031025R1	NSP
C7062	CHIP TYPE CERAMIC CAPACITOR	CK732B16V-106K	1	332071065R2	NSP
C7064	CHIP TYPE CERAMIC CAPACITOR	CK725B1C-104K0	1	332011045R1	NSP
C7067	CHIP TYPE CERAMIC CAPACITOR	CK725B1C-104K0	1	332011045R1	NSP
C7068	CHIP TYPE CERAMIC CAPACITOR	CK732B16V-106K	1	332071065R2	NSP
C7070	CHIP TYPE CERAMIC CAPACITOR	CK725B1C-104K0	1	332011045R1	NSP
C7071	CHIP TYPE CERAMIC CAPACITOR	CK732B16V-106K	1	332071065R2	NSP
C7075	CHIP TYPE CERAMIC CAPACITOR	CK725B1E-153K0	1	332021535R1	NSP
C7076	CHIP TYPE CERAMIC CAPACITOR	CK725B1H-104K1	1	332101045R1	NSP
C7077	CHIP TYPE CERAMIC CAPACITOR	CC725CH1H-101J0	1	342031014R1	NSP
C7078	CHIP TYPE CERAMIC CAPACITOR	CK725B1H-104K1	1	332101045R1	NSP
C7180	CHIP TYPE CERAMIC CAPACITOR	CK725B1H-102K0	1	332031025R1	NSP
C7181	CHIP TYPE CERAMIC CAPACITOR	CK725B1H-102K0	1	332031025R1	NSP
C7182	CHIP TYPE CERAMIC CAPACITOR	CK725B1H-102K0	1	332031025R1	NSP
C7183	CHIP TYPE CERAMIC CAPACITOR	CK725B1H-102K0	1	332031025R1	NSP
C7184	CHIP TYPE CERAMIC CAPACITOR	CK725B1A-105K0	1	332001055R1	NSP
C8038	CHIP TYPE CERAMIC CAPACITOR	CK725B1C-104K0	1	332011045R1	NSP
C8091	CHIP TYPE CERAMIC CAPACITOR	CK725B1C-104K0	1	332011045R1	NSP
C8092	CHIP TYPE CERAMIC CAPACITOR	CK725B1C-104K0	1	332011045R1	NSP
C8401	CHIP TYPE CERAMIC CAPACITOR	CK725B1C-104K0	1	332011045R1	NSP
C8402	CHIP TYPE CERAMIC CAPACITOR	CK725B1C-104K0	1	332011045R1	NSP
C8403	CHIP TYPE CERAMIC CAPACITOR	CK725B1C-104K0	1	332011045R1	NSP
C8404	CHIP TYPE CERAMIC CAPACITOR	CK725B1C-104K0	1	332011045R1	NSP
C8405	CHIP TYPE CERAMIC CAPACITOR	CK725B1C-104K0	1	332011045R1	NSP
C8406	CHIP TYPE CERAMIC CAPACITOR	CK725B1C-104K0	1	332011045R1	NSP
C8407	CHIP TYPE CERAMIC CAPACITOR	CK725B1C-104K0	1	332011045R1	NSP
C8408	CHIP TYPE CERAMIC CAPACITOR	CK725B1C-104K0	1	332011045R1	NSP
C8409	CHIP TYPE CERAMIC CAPACITOR	CK725B1C-104K0	1	332011045R1	NSP
C8410	CHIP TYPE CERAMIC CAPACITOR	CK725B1C-104K0	1	332011045R1	NSP
C8411	CHIP TYPE CERAMIC CAPACITOR	CK725B1C-104K0	1	332011045R1	NSP
C8412	CHIP TYPE CERAMIC CAPACITOR	CK725B1C-104K0	1	332011045R1	NSP
C8413	CHIP TYPE CERAMIC CAPACITOR	CK732B16V-106K	1	332071065R2	NSP
C8414	CHIP TYPE CERAMIC CAPACITOR	CK732B16V-106K	1	332071065R2	NSP
C8415	CHIP TYPE CERAMIC CAPACITOR	CK725B1C-104K0	1	332011045R1	NSP
C8416	CHIP TYPE CERAMIC CAPACITOR	CK725B1C-104K0	1	332011045R1	NSP
C8417	CHIP TYPE CERAMIC CAPACITOR	CK725B1C-104K0	1	332011045R1	NSP
C8418	CHIP TYPE CERAMIC CAPACITOR	CK725B1C-104K0	1	332011045R1	NSP
C8419	CHIP TYPE CERAMIC CAPACITOR	CK725B1C-104K0	1	332011045R1	NSP
C8420	CHIP TYPE CERAMIC CAPACITOR	CK725B1C-104K0	1	332011045R1	NSP
C8421	CHIP TYPE CERAMIC CAPACITOR	CK725B1C-104K0	1	332011045R1	NSP
C8422	CHIP TYPE CERAMIC CAPACITOR	CK725B1C-104K0	1	332011045R1	NSP
C8423	CHIP TYPE CERAMIC CAPACITOR	CK725B1C-104K0	1	332011045R1	NSP
C8424	CHIP TYPE CERAMIC CAPACITOR	CK725B1C-104K0	1	332011045R1	NSP
C8425	CHIP TYPE CERAMIC CAPACITOR	CK725B1C-104K0	1	332011045R1	NSP
C8426	CHIP TYPE CERAMIC CAPACITOR	CK725B1C-104K0	1	332011045R1	NSP
C8427	CHIP TYPE CERAMIC CAPACITOR	CK725B1C-104K0	1	332011045R1	NSP
C8428	CHIP TYPE CERAMIC CAPACITOR	CK732B16V-106K	1	332071065R2	NSP



C8918	CHIP TYPE CERAMIC CAPACITOR	CK725B0J-226M	1	332092267R2	NSP
C8921	CHIP TYPE CERAMIC CAPACITOR	CK725B1H-103K0	1	332031035R1	NSP
C8922	CHIP TYPE CERAMIC CAPACITOR	CK725B1C-104K0	1	332011045R1	NSP
C8923	CHIP TYPE CERAMIC CAPACITOR	CK725B1E-106K	1	332221065R2	NSP
C8924	CHIP TYPE CERAMIC CAPACITOR	CK725B1E-106K	1	332221065R2	NSP
C8925	CHIP TYPE CERAMIC CAPACITOR	CK725B1H-103K0	1	332031035R1	NSP
C8926	CHIP TYPE CERAMIC CAPACITOR	CK725B0J-226M	1	332092267R2	NSP
C8927	CHIP TYPE CERAMIC CAPACITOR	CK725B0J-226M	1	332092267R2	NSP
C8929	CHIP TYPE CERAMIC CAPACITOR	CK732B16V-106K	1	332071065R2	NSP
C8930	CHIP TYPE CERAMIC CAPACITOR	CK725B0J-226M	1	332092267R2	NSP
C8931	CHIP TYPE CERAMIC CAPACITOR	CK725B1H-103K0	1	332031035R1	NSP
C8932	CHIP TYPE CERAMIC CAPACITOR	CK725B1C-104K0	1	332011045R1	NSP
C8933	CHIP TYPE CERAMIC CAPACITOR	CK725B1E-106K	1	332221065R2	NSP
C8934	CHIP TYPE CERAMIC CAPACITOR	CK725B1E-106K	1	332221065R2	NSP
C8935	CHIP TYPE CERAMIC CAPACITOR	CK725B1H-103K0	1	332031035R1	NSP
C8936	CHIP TYPE CERAMIC CAPACITOR	CK725B0J-226M	1	332092267R2	NSP
C8937	CHIP TYPE CERAMIC CAPACITOR	CK725B0J-226M	1	332092267R2	NSP
C8951	CHIP TYPE CERAMIC CAPACITOR	CK725B1H-103K0	1	332031035R1	NSP
C8952	CHIP TYPE CERAMIC CAPACITOR	CK725B1C-104K0	1	332011045R1	NSP
C8953	CHIP TYPE CERAMIC CAPACITOR	CK725B1E-106K	1	332221065R2	NSP
C8954	CHIP TYPE CERAMIC CAPACITOR	CK725B1E-106K	1	332221065R2	NSP
C8955	CHIP TYPE CERAMIC CAPACITOR	CK725B1H-103K0	1	332031035R1	NSP
C8956	CHIP TYPE CERAMIC CAPACITOR	CK725B0J-226M	1	332092267R2	NSP
C8957	CHIP TYPE CERAMIC CAPACITOR	CK725B0J-226M	1	332092267R2	NSP
C8961	CHIP TYPE CERAMIC CAPACITOR	CK725B1H-103K0	1	332031035R1	NSP
C8962	CHIP TYPE CERAMIC CAPACITOR	CK725B1C-104K0	1	332011045R1	NSP
C8963	CHIP TYPE CERAMIC CAPACITOR	CK725B1E-106K	1	332221065R2	NSP
C8964	CHIP TYPE CERAMIC CAPACITOR	CK725B1E-106K	1	332221065R2	NSP
C8966	CHIP TYPE CERAMIC CAPACITOR	CK725B0J-226M	1	332092267R2	NSP
C8967	CHIP TYPE CERAMIC CAPACITOR	CK725B0J-226M	1	332092267R2	NSP
C8980	CHIP TYPE CERAMIC CAPACITOR	CK725B1A-105K0	1	332001055R1	NSP
C8981	CHIP TYPE CERAMIC CAPACITOR	CK732B16V-106K	1	332071065R2	NSP
C8984	CHIP TYPE CERAMIC CAPACITOR	CC725CH1H-102J1	1	342101024R1	NSP
C8985	CHIP TYPE CERAMIC CAPACITOR	CK725B0J-226M	1	332092267R2	NSP
C8986	CHIP TYPE CERAMIC CAPACITOR	CK725B0J-226M	1	332092267R2	NSP
C8987	CHIP TYPE CERAMIC CAPACITOR	CK725B0J-226M	1	332092267R2	NSP

**[ Resistors ]**

R1001	CHIP TYPE CARBON RESISTOR	RN72K1J-331JE	1	435033314R1	NSP
R1002	CHIP TYPE CARBON RESISTOR	RN72K1J-151JE	1	435031514R1	NSP
R1003	CHIP TYPE CARBON RESISTOR	RN72K1J-151JE	1	435031514R1	NSP
R1004	CHIP TYPE CARBON RESISTOR	RN72K1J-151JE	1	435031514R1	NSP
R1005	CHIP TYPE CARBON RESISTOR	RN72K1J-331JE	1	435033314R1	NSP
R1006	CHIP TYPE CARBON RESISTOR	RN72K1J-560JE	1	435035604R1	NSP
R1007	CHIP TYPE CARBON RESISTOR	RN72K1J-105JE	1	435031054R1	NSP
R1008	CHIP TYPE CARBON RESISTOR	RN72K1J-102JE	1	435031024R1	NSP
R1009	CHIP TYPE CARBON RESISTOR	RN72K1J-103JE	1	435031034R1	NSP
R1011	CHIP TYPE CARBON RESISTOR	RN72K1J-470JE	1	435034704R1	NSP
R1012	CHIP TYPE CARBON RESISTOR	RN72K1J-470JE	1	435034704R1	NSP
R1013	CHIP TYPE CARBON RESISTOR	RN72K1J-470JE	1	435034704R1	NSP
R1014	CHIP TYPE CARBON RESISTOR	RN72K1J-151JE	1	435031514R1	NSP
R1015	CHIP TYPE CARBON RESISTOR	RN72K1J-151JE	1	435031514R1	NSP
R1016	CHIP TYPE CARBON RESISTOR	RN72K1J-151JE	1	435031514R1	NSP
R1017	CHIP TYPE CARBON RESISTOR	RN72K1J-470JE	1	435034704R1	NSP
R1019	CHIP TYPE CARBON RESISTOR	RN72K1J-470JE	1	435034704R1	NSP
R1020	CHIP TYPE CARBON RESISTOR	RN72K1J-391JE	1	435033914R1	NSP

R1021	CHIP TYPE CARBON RESISTOR	RN72K1J-101JE	1	435031014R1	NSP
R1022	CHIP TYPE CARBON RESISTOR	RN72K1J-151JE	1	435031514R1	NSP
R1023	CHIP TYPE CARBON RESISTOR	RN72K1J-151JE	1	435031514R1	NSP
R1024	CHIP TYPE CARBON RESISTOR	RN72K1J-470JE	1	435034704R1	NSP
R1025	CHIP TYPE CARBON RESISTOR	RN72K1J-470JE	1	435034704R1	NSP
R1026	CHIP TYPE CARBON RESISTOR	RN72K1J-331JE	1	435033314R1	NSP
R1027	CHIP TYPE CARBON RESISTOR	RN72K1J-221JE	1	435032214R1	NSP
R1028	CHIP TYPE CARBON RESISTOR	RN72K1J-221JE	1	435032214R1	NSP
R1031	CHIP TYPE CARBON RESISTOR	RN72K1J-331JE	1	435033314R1	NSP
R1032	CHIP TYPE CARBON RESISTOR	RN72K1J-331JE	1	435033314R1	NSP
R1033	CHIP TYPE CARBON RESISTOR	RN72K1J-470JE	1	435034704R1	NSP
R1034	CHIP TYPE CARBON RESISTOR	RN72K1J-221JE	1	435032214R1	NSP
R1035	CHIP TYPE CARBON RESISTOR	RN72K1J-470JE	1	435034704R1	NSP
R1036	CHIP TYPE CARBON RESISTOR	RN72K1J-470JE	1	435034704R1	NSP
R1037	CHIP TYPE CARBON RESISTOR	RN72K1J-470JE	1	435034704R1	NSP
R1038	CHIP TYPE CARBON RESISTOR	RN72K1J-470JE	1	435034704R1	NSP
R1039	CHIP TYPE CARBON RESISTOR	RN72K1J-470JE	1	435034704R1	NSP
R1040	CHIP TYPE CARBON RESISTOR	RN72K1J-470JE	1	435034704R1	NSP
R1041	CHIP TYPE CARBON RESISTOR	RN72K1J-470JE	1	435034704R1	NSP
R1042	CHIP TYPE CARBON RESISTOR	RN72K1J-331JE	1	435033314R1	NSP
R1043	CHIP TYPE CARBON RESISTOR	RN72K1J-221JE	1	435032214R1	NSP
R1044	CHIP TYPE CARBON RESISTOR	RN72K1J-221JE	1	435032214R1	NSP
R1045	CHIP TYPE CARBON RESISTOR	RN72K1J-470JE	1	435034704R1	NSP
R1046	CHIP TYPE CARBON RESISTOR	RN72K1J-470JE	1	435034704R1	NSP
R1047	CHIP TYPE CARBON RESISTOR	RN72K1J-681JE	1	435036814R1	NSP
R1048	CHIP TYPE CARBON RESISTOR	RN72K1J-470JE	1	435034704R1	NSP
R1049	CHIP RESISTOR NETWORK	MNR04MRAPJ221	1	43464722104R2	NSP
R1049or	CHIP RESISTOR NETWORK	YCN104-221-JK	(1)	43464C22104R1	NSP
R1050	CHIP TYPE CARBON RESISTOR	RN72K1J-470JE	1	435034704R1	NSP
R1051	CHIP TYPE CARBON RESISTOR	RN72K1J-470JE	1	435034704R1	NSP
R1052	CHIP TYPE CARBON RESISTOR	RN72K1J-470JE	1	435034704R1	NSP
R1053	CHIP TYPE CARBON RESISTOR	RN72K1J-470JE	1	435034704R1	NSP
R1054	CHIP TYPE CARBON RESISTOR	RN72K1J-221JE	1	435032214R1	NSP
R1057	CHIP TYPE CARBON RESISTOR	RN72K1J-681JE	1	435036814R1	NSP
R1058	CHIP TYPE CARBON RESISTOR	RN72K1J-000JE	1	435030004R1	NSP
R1059	CHIP TYPE CARBON RESISTOR	RN72K1J-470JE	1	435034704R1	NSP
R1060	CHIP TYPE CARBON RESISTOR	RN72K1J-470JE	1	435034704R1	NSP
R1061	CHIP TYPE CARBON RESISTOR	RN72K1J-103JE	1	435031034R1	NSP
R1062	CHIP TYPE CARBON RESISTOR	RN72K1J-221JE	1	435032214R1	NSP
R1063	CHIP TYPE CARBON RESISTOR	RN72K1J-103JE	1	435031034R1	NSP
R1064	CHIP TYPE CARBON RESISTOR	RN72K1J-221JE	1	435032214R1	NSP
R1065	CHIP TYPE CARBON RESISTOR	RN72K1J-470JE	1	435034704R1	NSP
R1066	CHIP TYPE CARBON RESISTOR	RN72K1J-000JE	1	435030004R1	NSP
R1067	CHIP TYPE CARBON RESISTOR	RN72K1J-000JE	1	435030004R1	NSP
R1068	CHIP TYPE CARBON RESISTOR	RN72K1J-000JE	1	435030004R1	NSP
R1069	CHIP TYPE CARBON RESISTOR	RN72K1J-000JE	1	435030004R1	NSP
R1070	CHIP TYPE CARBON RESISTOR	RN72K1J-000JE	1	435030004R1	NSP
R1071	CHIP TYPE CARBON RESISTOR	RN72K1J-470JE	1	435034704R1	NSP
R1072	CHIP TYPE CARBON RESISTOR	RN72K1J-470JE	1	435034704R1	NSP
R1073	CHIP TYPE CARBON RESISTOR	RN72K1J-470JE	1	435034704R1	NSP
R1074	CHIP TYPE CARBON RESISTOR	RN72K1J-470JE	1	435034704R1	NSP
R1075	CHIP TYPE CARBON RESISTOR	RN72K1J-103JE	1	435031034R1	NSP
R1076	CHIP TYPE CARBON RESISTOR	RN72K1J-330JE	1	435033304R1	NSP
R1077	CHIP TYPE CARBON RESISTOR	RN72K1J-330JE	1	435033304R1	NSP
R1078	CHIP TYPE PLASTIC FILM CAPACITOR	50MU103KY11608	1	376921035R2	NSP

R1079	CHIP TYPE PLASTIC FILM CAPACITOR	50MU103KY11608	1	376921035R2	NSP
R1080	CHIP TYPE CARBON RESISTOR	RN72K1J-470JE	1	435034704R1	NSP
R1081	CHIP TYPE CARBON RESISTOR	RN72K1J-181JE	1	435031814R1	NSP
R1082	CHIP TYPE CARBON RESISTOR	RN72K1J-470JE	1	435034704R1	NSP
R1083	CHIP TYPE CARBON RESISTOR	RN72K1J-221JE	1	435032214R1	NSP
R1084	CHIP TYPE CARBON RESISTOR	RN72K1J-470JE	1	435034704R1	NSP
R1085	CHIP TYPE CARBON RESISTOR	RN72K1J-181JE	1	435031814R1	NSP
R1086	CHIP TYPE CARBON RESISTOR	RN72K1J-470JE	1	435034704R1	NSP
R1087	CHIP TYPE CARBON RESISTOR	RN72K1J-471JE	1	435034714R1	NSP
R1088	CHIP TYPE CARBON RESISTOR	RN72K1J-471JE	1	435034714R1	NSP
R1089	CHIP TYPE CARBON RESISTOR	RN72K1J-470JE	1	435034704R1	NSP
R1090	CHIP TYPE CARBON RESISTOR	RN72K1J-470JE	1	435034704R1	NSP
R1091	CHIP TYPE CARBON RESISTOR	RN72K1J-470JE	1	435034704R1	NSP
R1092	CHIP TYPE CARBON RESISTOR	RN72K1J-470JE	1	435034704R1	NSP
R1093	CHIP TYPE CARBON RESISTOR	RN72K1J-103JE	1	435031034R1	NSP
R1095	CHIP TYPE CARBON RESISTOR	RN72K1J-470JE	1	435034704R1	NSP
R1097	CHIP TYPE CARBON RESISTOR	RN72K1J-470JE	1	435034704R1	NSP
R1098	CHIP TYPE CARBON RESISTOR	RN72K1J-470JE	1	435034704R1	NSP
R1099	CHIP TYPE CARBON RESISTOR	RN72K1J-470JE	1	435034704R1	NSP
R1115	CHIP TYPE CARBON RESISTOR	RN72K1J-221JE	1	435032214R1	NSP
R1133	CHIP TYPE CARBON RESISTOR	RN72K1J-470JE	1	435034704R1	NSP
R1135	CHIP TYPE CARBON RESISTOR	RN72K1J-470JE	1	435034704R1	NSP
R1137	CHIP TYPE CARBON RESISTOR	RN72K1J-470JE	1	435034704R1	NSP
R1138	CHIP TYPE CARBON RESISTOR	RN72K1J-000JE	1	435030004R1	NSP
R1140	CHIP TYPE CARBON RESISTOR	RN72K1J-000JE	1	435030004R1	NSP
R1141	CHIP TYPE CARBON RESISTOR	RN72K1J-470JE	1	435034704R1	NSP
R1143	CHIP TYPE CARBON RESISTOR	RN72K1J-470JE	1	435034704R1	NSP
R1144	CHIP TYPE CARBON RESISTOR	RN72K1J-470JE	1	435034704R1	NSP
R1145	CHIP TYPE CARBON RESISTOR	RN72K1J-470JE	1	435034704R1	NSP
R1146	CHIP TYPE CARBON RESISTOR	RN72K1J-470JE	1	435034704R1	NSP
R1147	CHIP TYPE CARBON RESISTOR	RN72K1J-470JE	1	435034704R1	NSP
R1149	CHIP TYPE CARBON RESISTOR	RN72K1J-331JE	1	435033314R1	NSP
R1150	CHIP TYPE CARBON RESISTOR	RN72K1J-331JE	1	435033314R1	NSP
R1151	CHIP TYPE CARBON RESISTOR	RN72K1J-000JE	1	435030004R1	NSP
R1152	CHIP TYPE CARBON RESISTOR	RN72K1J-000JE	1	435030004R1	NSP
R1158	CHIP TYPE CARBON RESISTOR	RN72K1J-330JE	1	435033304R1	NSP
R1160	CHIP TYPE CARBON RESISTOR	RN72K1J-330JE	1	435033304R1	NSP
R1174	CHIP TYPE CARBON RESISTOR	RN72K1J-000JE	1	435030004R1	NSP
R3260	CHIP TYPE CARBON RESISTOR	RN72K1J-103JE	1	435031034R1	NSP
R3400	CHIP TYPE CARBON RESISTOR	RN72K1J-103JE	1	435031034R1	NSP
R3401	CHIP TYPE CARBON RESISTOR	RN72K1J-470JE	1	435034704R1	NSP
R3403	CHIP TYPE CARBON RESISTOR	RN72K1J-221JE	1	435032214R1	NSP
R3404	CHIP TYPE CARBON RESISTOR	RN72K1J-470JE	1	435034704R1	NSP
R3405	CHIP TYPE CARBON RESISTOR	RN72K1J-470JE	1	435034704R1	NSP
R3406	CHIP TYPE CARBON RESISTOR	RN72K1J-332JE	1	435033324R1	NSP
R3407	CHIP TYPE CARBON RESISTOR	RN72K1J-222JE	1	435032224R1	NSP
R3408	CHIP RESISTOR NETWORK	MNR04MRAPJ221	1	43464722104R2	NSP
R3408or	CHIP RESISTOR NETWORK	YCN104-221-JK	(1)	43464C22104R1	NSP
R3409	CHIP RESISTOR NETWORK	MNR04MRAPJ221	1	43464722104R2	NSP
R3409or	CHIP RESISTOR NETWORK	YCN104-221-JK	(1)	43464C22104R1	NSP
R3410	CHIP TYPE CARBON RESISTOR	RN72K1J-220JE	1	435032204R1	NSP
R3411	CHIP RESISTOR NETWORK	MNR04MRAPJ000	1	43464700004R2	NSP
R3411or	CHIP RESISTOR NETWORK	YCN104-000-ZK	(1)	43484C00004R1	NSP
R3412	CHIP TYPE CARBON RESISTOR	RN72K1J-472JE	1	435034724R1	NSP
R3413	CHIP TYPE CARBON RESISTOR	RN72K1J-470JE	1	435034704R1	NSP

R3414	CHIP TYPE CARBON RESISTOR	RN72K1J-103JE	1	435031034R1	NSP
R3415	CHIP RESISTOR NETWORK	MNR04MRAPJ000	1	43464700004R2	NSP
R3415or	CHIP RESISTOR NETWORK	YCN104-000-ZK	(1)	43484C00004R1	NSP
R3416	CHIP TYPE CARBON RESISTOR	RN72K1J-151JE	1	435031514R1	NSP
R3417	CHIP TYPE CARBON RESISTOR	RN72K1J-470JE	1	435034704R1	NSP
R3418	CHIP TYPE CARBON RESISTOR	RN72K1J-103JE	1	435031034R1	NSP
R3421	CHIP TYPE CARBON RESISTOR	RN72K1J-470JE	1	435034704R1	NSP
R3424	CHIP TYPE CARBON RESISTOR	RN72K1J-470JE	1	435034704R1	NSP
R3425	CHIP TYPE CARBON RESISTOR	RN72K1J-470JE	1	435034704R1	NSP
R3428	CHIP TYPE CARBON RESISTOR	RN72K1J-472JE	1	435034724R1	NSP
R3429	CHIP RESISTOR NETWORK	MNR04MRAPJ470	1	43464747004R2	NSP
R3429or	CHIP RESISTOR NETWORK	YCN104-470-JK	(1)	43464C47004R1	NSP
R3430	CHIP RESISTOR NETWORK	MNR04MRAPJ470	1	43464747004R2	NSP
R3430or	CHIP RESISTOR NETWORK	YCN104-470-JK	(1)	43464C47004R1	NSP
R3433	CHIP TYPE CARBON RESISTOR	RN72K1J-103JE	1	435031034R1	NSP
R3434	CHIP TYPE CARBON RESISTOR	RN72K1J-332JE	1	435033324R1	NSP
R3435	CHIP TYPE CARBON RESISTOR	RN72K1J-222JE	1	435032224R1	NSP
R3436	CHIP TYPE CARBON RESISTOR	RN72K1J-470JE	1	435034704R1	NSP
R3437	CHIP TYPE CARBON RESISTOR	RN72K1J-470JE	1	435034704R1	NSP
R3438	CHIP TYPE CARBON RESISTOR	RN72K1J-470JE	1	435034704R1	NSP
R3439	CHIP TYPE CARBON RESISTOR	RN72K1J-332JE	1	435033324R1	NSP
R3440	CHIP TYPE CARBON RESISTOR	RN72K1J-332JE	1	435033324R1	NSP
R3441	CHIP RESISTOR NETWORK	MNR04MRAPJ470	1	43464747004R2	NSP
R3441or	CHIP RESISTOR NETWORK	YCN104-470-JK	(1)	43464C47004R1	NSP
R3442	CHIP TYPE CARBON RESISTOR	RN72K1J-105JE	1	435031054R1	NSP
R3443	CHIP TYPE CARBON RESISTOR	RN72K1J-000JE	1	435030004R1	NSP
R3444	CHIP TYPE CARBON RESISTOR	RN72K1J-470JE	1	435034704R1	NSP
R3445	CHIP RESISTOR NETWORK	MNR04MRAPJ470	1	43464747004R2	NSP
R3445or	CHIP RESISTOR NETWORK	YCN104-470-JK	(1)	43464C47004R1	NSP
R3446	CHIP TYPE CARBON RESISTOR	RN72K1J-102JE	1	435031024R1	NSP
R3447	CHIP TYPE CARBON RESISTOR	RN72K1J-470JE	1	435034704R1	NSP
R3448	CHIP TYPE CARBON RESISTOR	RN72K1J-470JE	1	435034704R1	NSP
R3450	CHIP TYPE CARBON RESISTOR	RN72K1J-470JE	1	435034704R1	NSP
R3452	CHIP TYPE CARBON RESISTOR	RN72K1J-470JE	1	435034704R1	NSP
R3453	CHIP TYPE CARBON RESISTOR	RN72K1J-221JE	1	435032214R1	NSP
R3454	CHIP TYPE CARBON RESISTOR	RN72K1J-470JE	1	435034704R1	NSP
R3455	CHIP TYPE CARBON RESISTOR	RN72K1J-101JE	1	435031014R1	NSP
R3456	CHIP TYPE CARBON RESISTOR	RN72K1J-470JE	1	435034704R1	NSP
R3457	CHIP RESISTOR NETWORK	MNR04MRAPJ470	1	43464747004R2	NSP
R3457or	CHIP RESISTOR NETWORK	YCN104-470-JK	(1)	43464C47004R1	NSP
R3462	CHIP TYPE CARBON RESISTOR	RN72K1J-102JE	1	435031024R1	NSP
R3464	CHIP TYPE CARBON RESISTOR	RN72K1J-102JE	1	435031024R1	NSP
R3465	CHIP TYPE CARBON RESISTOR	RN72K1J-102JE	1	435031024R1	NSP
R3466	CHIP TYPE CARBON RESISTOR	RN72K1J-102JE	1	435031024R1	NSP
R3469	CHIP TYPE CARBON RESISTOR	RN72K1J-222JE	1	435032224R1	NSP
R3470	CHIP TYPE CARBON RESISTOR	RN72K1J-222JE	1	435032224R1	NSP
R3473	CHIP TYPE CARBON RESISTOR	RN72K1J-103JE	1	435031034R1	NSP
R3474	CHIP TYPE CARBON RESISTOR	RN72K1J-103JE	1	435031034R1	NSP
R3481	CHIP TYPE CARBON RESISTOR	RN72K1J-332JE	1	435033324R1	NSP
R3484	CHIP TYPE CARBON RESISTOR	RN72K1J-470JE	1	435034704R1	NSP
R3485	CHIP TYPE CARBON RESISTOR	RN72K1J-470JE	1	435034704R1	NSP
R3488	CHIP TYPE CARBON RESISTOR	RN72K1J-332JE	1	435033324R1	NSP
R3491	CHIP TYPE CARBON RESISTOR	RN72K1J-332JE	1	435033324R1	NSP
R3494	CHIP RESISTOR NETWORK	MNR04MRAPJ470	1	43464747004R2	NSP
R3494or	CHIP RESISTOR NETWORK	YCN104-470-JK	(1)	43464C47004R1	NSP

R3495	CHIP RESISTOR NETWORK	MNR04MRAPJ470	1	43464747004R2	NSP
R3495or	CHIP RESISTOR NETWORK	YCN104-470-JK	(1)	43464C47004R1	NSP
R3496	CHIP RESISTOR NETWORK	MNR04MRAPJ470	1	43464747004R2	NSP
R3496or	CHIP RESISTOR NETWORK	YCN104-470-JK	(1)	43464C47004R1	NSP
R3497	CHIP RESISTOR NETWORK	MNR04MRAPJ470	1	43464747004R2	NSP
R3497or	CHIP RESISTOR NETWORK	YCN104-470-JK	(1)	43464C47004R1	NSP
R3500	CHIP TYPE CARBON RESISTOR	RN72K1J-470JE	1	435034704R1	NSP
R3501	CHIP TYPE CARBON RESISTOR	RN72K1J-470JE	1	435034704R1	NSP
R3502	CHIP TYPE CARBON RESISTOR	RN72K1J-470JE	1	435034704R1	NSP
R3503	CHIP TYPE CARBON RESISTOR	RN72K1J-470JE	1	435034704R1	NSP
R3504	CHIP TYPE CARBON RESISTOR	RN72K1J-470JE	1	435034704R1	NSP
R3505	CHIP TYPE CARBON RESISTOR	RN72K1J-470JE	1	435034704R1	NSP
R3601	CHIP TYPE CARBON RESISTOR	RN72K1J-103JE	1	435031034R1	NSP
R3602	CHIP TYPE CARBON RESISTOR	RN72K1J-103JE	1	435031034R1	NSP
R3605	CHIP TYPE CARBON RESISTOR	RN72K1J-102JE	1	435031024R1	NSP
R3606	CHIP TYPE CARBON RESISTOR	RN72K1J-102JE	1	435031024R1	NSP
R3608	CHIP TYPE CARBON RESISTOR	RN72K1J-000JE	1	435030004R1	NSP
R3609	CHIP TYPE CARBON RESISTOR	RN72K1J-000JE	1	435030004R1	NSP
R3717	CHIP TYPE CARBON RESISTOR	RN72K1J-000JE	1	435030004R1	NSP
R3718	CHIP TYPE CARBON RESISTOR	RN72K1J-000JE	1	435030004R1	NSP
R3719	CHIP TYPE CARBON RESISTOR	RN72K1J-000JE	1	435030004R1	NSP
R3720	CHIP TYPE CARBON RESISTOR	RN72K1J-000JE	1	435030004R1	NSP
R3724	CHIP TYPE CARBON RESISTOR	RN72K1J-000JE	1	435030004R1	NSP
R7001	CHIP RESISTOR NETWORK	MNR04MRAPJ470	1	43464747004R2	NSP
R7001or	CHIP RESISTOR NETWORK	YCN104-470-JK	(1)	43464C47004R1	NSP
R7002	CHIP TYPE CARBON RESISTOR	RN72K1J-103JE	1	435031034R1	NSP
R7003	CHIP TYPE CARBON RESISTOR	RN72K1J-103JE	1	435031034R1	NSP
R7005	CHIP TYPE CARBON RESISTOR	RN72K1J-223JE	1	435032234R1	NSP
R7006	CHIP TYPE CARBON RESISTOR	RN72K1J-223JE	1	435032234R1	NSP
R7007	CHIP TYPE CARBON RESISTOR	RN72K1J-105JE	1	435031054R1	NSP
R7008	CHIP TYPE CARBON RESISTOR	RN72K1J-473JE	1	435034734R1	NSP
R7009	CHIP TYPE CARBON RESISTOR	RN72K1J-105JE	1	435031054R1	NSP
R7011	CHIP TYPE CARBON RESISTOR	RN72K1J-103JE	1	435031034R1	NSP
R7012	CHIP TYPE CARBON RESISTOR	RN72K1J-103JE	1	435031034R1	NSP
R7013	CHIP TYPE CARBON RESISTOR	RN72K1J-103JE	1	435031034R1	NSP
R7014	CHIP TYPE CARBON RESISTOR	RN72K1J-473JE	1	435034734R1	NSP
R7015	CHIP TYPE CARBON RESISTOR	RN72K1J-473JE	1	435034734R1	NSP
R7016	CHIP TYPE CARBON RESISTOR	RN72K1J-473JE	1	435034734R1	NSP
R7017	CHIP RESISTOR NETWORK	MNR04MRAPJ472	1	43464747204R2	NSP
R7017or	CHIP RESISTOR NETWORK	YCN104-472-JK	(1)	43464C47204R1	NSP
R7018	CHIP TYPE CARBON RESISTOR	RN72K1J-221JE	1	435032214R1	NSP
R7019	CHIP RESISTOR NETWORK	MNR04MRAPJ221	1	43464722104R2	NSP
R7019or	CHIP RESISTOR NETWORK	YCN104-221-JK	(1)	43464C22104R1	NSP
R7020	CHIP TYPE CARBON RESISTOR	RN72K1J-221JE	1	435032214R1	NSP
R7021	CHIP RESISTOR NETWORK	MNR04MRAPJ221	1	43464722104R2	NSP
R7021or	CHIP RESISTOR NETWORK	YCN104-221-JK	(1)	43464C22104R1	NSP
R7023	CHIP TYPE CARBON RESISTOR	RN72K1J-224JE	1	435032244R1	NSP
R7024	CHIP TYPE CARBON RESISTOR	RN72K1J-470JE	1	435034704R1	NSP
R7025	CHIP TYPE CARBON RESISTOR	RN72K1J-224JE	1	435032244R1	NSP
R7026	CHIP TYPE CARBON RESISTOR	RN72K1J-224JE	1	435032244R1	NSP
R7027	CHIP TYPE CARBON RESISTOR	RN72K1J-470JE	1	435034704R1	NSP
R7028	CHIP TYPE CARBON RESISTOR	RN72K1J-470JE	1	435034704R1	NSP
R7029	CHIP TYPE CARBON RESISTOR	RN72K1J-102JE	1	435031024R1	NSP
R7030	CHIP TYPE CARBON RESISTOR	RN72K1J-221JE	1	435032214R1	NSP
R7031	CHIP RESISTOR NETWORK	MNR04MRAPJ221	1	43464722104R2	NSP



R7031or	CHIP RESISTOR NETWORK	YCN104-221-JK	(1)	43464C22104R1	NSP
R7032	CHIP TYPE CARBON RESISTOR	RN72K1J-470JE	1	435034704R1	NSP
R7033	CHIP RESISTOR NETWORK	MNR04MRAPJ470	1	43464747004R2	NSP
R7033or	CHIP RESISTOR NETWORK	YCN104-470-JK	(1)	43464C47004R1	NSP
R7034	CHIP RESISTOR NETWORK	MNR04MRAPJ221	1	43464722104R2	NSP
R7034or	CHIP RESISTOR NETWORK	YCN104-221-JK	(1)	43464C22104R1	NSP
R7035	CHIP TYPE CARBON RESISTOR	RN72K1J-470JE	1	435034704R1	NSP
R7036	CHIP TYPE CARBON RESISTOR	RN72K1J-102JE	1	435031024R1	NSP
R7038	CHIP TYPE CARBON RESISTOR	RN72K1J-102JE	1	435031024R1	NSP
R7039	CHIP TYPE CARBON RESISTOR	RN72K1J-222JE	1	435032224R1	NSP
R7041	CHIP TYPE CARBON RESISTOR	RN72K1J-222JE	1	435032224R1	NSP
R7042	CHIP RESISTOR NETWORK	MNR04MRAPJ221	1	43464722104R2	NSP
R7042or	CHIP RESISTOR NETWORK	YCN104-221-JK	(1)	43464C22104R1	NSP
R7044	CHIP TYPE CARBON RESISTOR	RN72K1J-470JE	1	435034704R1	NSP
R7046	CHIP TYPE CARBON RESISTOR	RN72K1J-221JE	1	435032214R1	NSP
R7048	CHIP TYPE CARBON RESISTOR	RN72K1J-221JE	1	435032214R1	NSP
R7049	CHIP TYPE CARBON RESISTOR	RN72K1J-470JE	1	435034704R1	NSP
R7050	CHIP TYPE CARBON RESISTOR	RN72K1J-103JE	1	435031034R1	NSP
R7051	CHIP TYPE CARBON RESISTOR	RN72K1J-105JE	1	435031054R1	NSP
R7052	CHIP TYPE CARBON RESISTOR	RN72K1J-223JE	1	435032234R1	NSP
R7054	CHIP TYPE CARBON RESISTOR	RN72K1J-102JE	1	435031024R1	NSP
R7055	CHIP TYPE CARBON RESISTOR	RN72K1J-102JE	1	435031024R1	NSP
R7059	CHIP TYPE CARBON RESISTOR	RN72K1J-224JE	1	435032244R1	NSP
R7061	CHIP RESISTOR NETWORK	MNR04MRAPJ221	1	43464722104R2	NSP
R7061or	CHIP RESISTOR NETWORK	YCN104-221-JK	(1)	43464C22104R1	NSP
R7063	CHIP TYPE CARBON RESISTOR	RN72K1J-000JE	1	435030004R1	NSP
R7064	CHIP TYPE CARBON RESISTOR	RN72K1J-000JE	1	435030004R1	NSP
R7065	CHIP TYPE CARBON RESISTOR	RN72K1J-473JE	1	435034734R1	NSP
R7066	CHIP TYPE CARBON RESISTOR	RN72K1J-470JE	1	435034704R1	NSP
R7069	CHIP RESISTOR NETWORK	MNR04MRAPJ470	1	43464747004R2	NSP
R7069or	CHIP RESISTOR NETWORK	YCN104-470-JK	(1)	43464C47004R1	NSP
R7070	CHIP RESISTOR NETWORK	MNR04MRAPJ221	1	43464722104R2	NSP
R7070or	CHIP RESISTOR NETWORK	YCN104-221-JK	(1)	43464C22104R1	NSP
R7071	CHIP TYPE CARBON RESISTOR	RN72K1J-103JE	1	435031034R1	NSP
R7072	CHIP TYPE CARBON RESISTOR	RN72K1J-470JE	1	435034704R1	NSP
R7073	CHIP TYPE CARBON RESISTOR	RN72K1J-102JE	1	435031024R1	NSP
R7074	CHIP TYPE CARBON RESISTOR	RN72K1J-470JE	1	435034704R1	NSP
R7075	CHIP RESISTOR NETWORK	MNR04MRAPJ470	1	43464747004R2	NSP
R7075or	CHIP RESISTOR NETWORK	YCN104-470-JK	(1)	43464C47004R1	NSP
R7076	CHIP TYPE CARBON RESISTOR	RN72K1J-221JE	1	435032214R1	NSP
R7077	CHIP TYPE CARBON RESISTOR	RN72K1J-103JE	1	435031034R1	NSP
R7079	CHIP RESISTOR NETWORK	MNR04MRAPJ221	1	43464722104R2	NSP
R7079or	CHIP RESISTOR NETWORK	YCN104-221-JK	(1)	43464C22104R1	NSP
R7080	CHIP TYPE CARBON RESISTOR	RN72K1J-103JE	1	435031034R1	NSP
R7081	CHIP RESISTOR NETWORK	MNR04MRAPJ221	1	43464722104R2	NSP
R7081or	CHIP RESISTOR NETWORK	YCN104-221-JK	(1)	43464C22104R1	NSP
R7082	CHIP TYPE CARBON RESISTOR	RN72K1J-104JE	1	435031044R1	NSP
R7083	CHIP TYPE CARBON RESISTOR	RN72K1J-332JE	1	435033324R1	NSP
R7084	CHIP TYPE CARBON RESISTOR	RN72K1J-331JE	1	435033314R1	NSP
R7086	CHIP TYPE CARBON RESISTOR	RN72K1J-330JE	1	435033304R1	NSP
R7087	CHIP TYPE CARBON RESISTOR	RN72K1J-273JE	1	435032734R1	NSP
R7088	CHIP TYPE CARBON RESISTOR	RN72K1J-330JE	1	435033304R1	NSP
R7089	CHIP TYPE CARBON RESISTOR	RN72K1J-330JE	1	435033304R1	NSP
R7090	CHIP TYPE CARBON RESISTOR	RN72K1J-330JE	1	435033304R1	NSP
R7091	CHIP TYPE CARBON RESISTOR	RN72K1J-221JE	1	435032214R1	NSP

R7092	CHIP TYPE CARBON RESISTOR	RN72K1J-470JE	1	435034704R1	NSP
R7093	CHIP TYPE CARBON RESISTOR	RN72K1J-472JE	1	435034724R1	NSP
R7094	CHIP TYPE CARBON RESISTOR	RN72K1J-472JE	1	435034724R1	NSP
R7095	CHIP RESISTOR NETWORK	MNR04MRAPJ221	1	43464722104R2	NSP
R7095or	CHIP RESISTOR NETWORK	YCN104-221-JK	(1)	43464C22104R1	NSP
R7096	CHIP TYPE CARBON RESISTOR	RN72K1J-330JE	1	435033304R1	NSP
R7097	CHIP TYPE CARBON RESISTOR	RN72K1J-470JE	1	435034704R1	NSP
R7098	CHIP RESISTOR NETWORK	MNR04MRAPJ221	1	43464722104R2	NSP
R7098or	CHIP RESISTOR NETWORK	YCN104-221-JK	(1)	43464C22104R1	NSP
R7099	CHIP RESISTOR NETWORK	MNR04MRAPJ470	1	43464747004R2	NSP
R7099or	CHIP RESISTOR NETWORK	YCN104-470-JK	(1)	43464C47004R1	NSP
R7100	CHIP TYPE CARBON RESISTOR	RN72K1J-104JE	1	435031044R1	NSP
R7101	CHIP TYPE CARBON RESISTOR	RN72K1J-221JE	1	435032214R1	NSP
R7102	CHIP TYPE CARBON RESISTOR	RN72K1J-331JE	1	435033314R1	NSP
R7103	CHIP TYPE CARBON RESISTOR	RN72K1J-221JE	1	435032214R1	NSP
R7104	CHIP TYPE CARBON RESISTOR	RN72K1J-470JE	1	435034704R1	NSP
R7105	CHIP RESISTOR NETWORK	MNR04MRAPJ470	1	43464747004R2	NSP
R7105or	CHIP RESISTOR NETWORK	YCN104-470-JK	(1)	43464C47004R1	NSP
R7106	CHIP TYPE CARBON RESISTOR	RN72K1J-473JE	1	435034734R1	NSP
R7107	CHIP TYPE CARBON RESISTOR	RN72K1J-272JE	1	435032724R1	NSP
R7108	CHIP RESISTOR NETWORK	MNR04MRAPJ103	1	43464710304R2	NSP
R7108or	CHIP RESISTOR NETWORK	YCN104-103-JK	(1)	43464C10304R1	NSP
R7109	CHIP TYPE CARBON RESISTOR	RN72K1J-331JE	1	435033314R1	NSP
R7110	CHIP TYPE CARBON RESISTOR	RN72K1J-103JE	1	435031034R1	NSP
R7111	CHIP TYPE CARBON RESISTOR	RN72K1J-103JE	1	435031034R1	NSP
R7112	CHIP TYPE CARBON RESISTOR	RN72K1J-103JE	1	435031034R1	NSP
R7113	CHIP TYPE CARBON RESISTOR	RN72K1J-470JE	1	435034704R1	NSP
R7114	CHIP TYPE CARBON RESISTOR	RN72K1J-103JE	1	435031034R1	NSP
R7115	CHIP TYPE CARBON RESISTOR	RN72K1J-272JE	1	435032724R1	NSP
R7116	CHIP TYPE CARBON RESISTOR	RN72K1J-272JE	1	435032724R1	NSP
R7117	CHIP TYPE CARBON RESISTOR	RN72K1J-272JE	1	435032724R1	NSP
R7120	CHIP TYPE CARBON RESISTOR	RN72K1J-103JE	1	435031034R1	NSP
R7121	CHIP TYPE CARBON RESISTOR	RN72K1J-105JE	1	435031054R1	NSP
R7122	CHIP TYPE CARBON RESISTOR	RN72K1J-105JE	1	435031054R1	NSP
R7123	CHIP RESISTOR NETWORK	MNR04MRAPJ221	1	43464722104R2	NSP
R7123or	CHIP RESISTOR NETWORK	YCN104-221-JK	(1)	43464C22104R1	NSP
R7124	CHIP TYPE CARBON RESISTOR	RN72K1J-330JE	1	435033304R1	NSP
R7127	CHIP TYPE CARBON RESISTOR	RN72K1J-101JE	1	435031014R1	NSP
R7131	CHIP TYPE CARBON RESISTOR	RN72K1J-101JE	1	435031014R1	NSP
R7132	CHIP TYPE CARBON RESISTOR	RN72K1J-331JE	1	435033314R1	NSP
R7133	CHIP TYPE CARBON RESISTOR	RN72K1J-221JE	1	435032214R1	NSP
R7134	CHIP TYPE CARBON RESISTOR	RN72K1J-221JE	1	435032214R1	NSP
R7135	CHIP TYPE CARBON RESISTOR	RN72K1J-103JE	1	435031034R1	NSP
R7136	CHIP TYPE CARBON RESISTOR	RN72K1J-470JE	1	435034704R1	NSP
R7137	CHIP TYPE CARBON RESISTOR	RN72K1J-221JE	1	435032214R1	NSP
R7138	CHIP TYPE CARBON RESISTOR	RN72K1J-470JE	1	435034704R1	NSP
R7140	CHIP TYPE CARBON RESISTOR	RN72K1J-103JE	1	435031034R1	NSP
R7141	CHIP TYPE CARBON RESISTOR	RN72K1J-103JE	1	435031034R1	NSP
R7142	CHIP TYPE CARBON RESISTOR	RN72K1J-470JE	1	435034704R1	NSP
R7148	CHIP TYPE CARBON RESISTOR	RN72K1J-000JE	1	435030004R1	NSP
R7149	CHIP TYPE CARBON RESISTOR	RN72K1J-103JE	1	435031034R1	NSP
R7161	CHIP TYPE CARBON RESISTOR	RN72K1J-103JE	1	435031034R1	NSP
R7184	CHIP TYPE CARBON RESISTOR	RN72K1J-103JE	1	435031034R1	NSP
R7186	CHIP TYPE CARBON RESISTOR	RN72K1J-104JE	1	435031044R1	NSP
R7187	CHIP TYPE CARBON RESISTOR	RN72K1J-104JE	1	435031044R1	NSP

R7188	CHIP TYPE CARBON RESISTOR	RN72K1J-104JE	1	435031044R1	NSP
R7191	CHIP TYPE CARBON RESISTOR	RN72K1J-000JE	1	435030004R1	NSP
R7192	CHIP TYPE CARBON RESISTOR	RN72K1J-000JE	1	435030004R1	NSP
R7193	CHIP TYPE CARBON RESISTOR	RN72K1J-221JE	1	435032214R1	NSP
R8011	CHIP TYPE CARBON RESISTOR	RN72K1J-473JE	1	435034734R1	NSP
R8021	CHIP TYPE CARBON RESISTOR	RN72K1J-182JE	1	435031824R1	NSP
R8022	CHIP TYPE CARBON RESISTOR	RN72K1J-182JE	1	435031824R1	NSP
R8024	CHIP TYPE CARBON RESISTOR	RN72K1J-473JE	1	435034734R1	NSP
R8025	CHIP TYPE CARBON RESISTOR	RN72K1J-000JE	1	435030004R1	NSP
R8030	CHIP TYPE CARBON RESISTOR	RN72K1J-473JE	1	435034734R1	NSP
R8037	CHIP TYPE CARBON RESISTOR	RN72K1J-102JE	1	435031024R1	NSP
R8038	CHIP TYPE CARBON RESISTOR	RN72K1J-102JE	1	435031024R1	NSP
R8075	CHIP TYPE CARBON RESISTOR	RN72K1J-473JE	1	435034734R1	NSP
R8400	CHIP RESISTOR NETWORK	MNR04MRAPJ103	1	43464710304R2	NSP
R8400or	CHIP RESISTOR NETWORK	YCN104-103-JK	(1)	43464C10304R1	NSP
R8401	CHIP TYPE CARBON RESISTOR	RN72K1J-103JE	1	435031034R1	NSP
R8402	CHIP RESISTOR NETWORK	MNR04MRAPJ470	1	43464747004R2	NSP
R8402or	CHIP RESISTOR NETWORK	YCN104-470-JK	(1)	43464C47004R1	NSP
R8403	CHIP TYPE CARBON RESISTOR	RN72K1J-473JE	1	435034734R1	NSP
R8405	CHIP TYPE CARBON RESISTOR	RN72K1J-470JE	1	435034704R1	NSP
R8406	CHIP TYPE CARBON RESISTOR	RN72K1J-101JE	1	435031014R1	NSP
R8407	CHIP TYPE CARBON RESISTOR	RN72K1J-470JE	1	435034704R1	NSP
R8408	CHIP TYPE CARBON RESISTOR	RN72K1J-470JE	1	435034704R1	NSP
R8410	CHIP TYPE CARBON RESISTOR	RN72K1J-000JE	1	435030004R1	NSP
R8411	CHIP TYPE CARBON RESISTOR	RN72K1J-103JE	1	435031034R1	NSP
R8414	CHIP TYPE CARBON RESISTOR	RN72K1J-470JE	1	435034704R1	NSP
R8415	CHIP TYPE CARBON RESISTOR	RN72K1J-470JE	1	435034704R1	NSP
R8416	CHIP TYPE CARBON RESISTOR	RN72K1J-101JE	1	435031014R1	NSP
R8417	CHIP TYPE CARBON RESISTOR	RN72K1J-105JE	1	435031054R1	NSP
R8418	CHIP TYPE CARBON RESISTOR	RN72K1J-470JE	1	435034704R1	NSP
R8419	CHIP TYPE CARBON RESISTOR	RN72K1J-470JE	1	435034704R1	NSP
R8420	CHIP TYPE CARBON RESISTOR	RN72K1J-470JE	1	435034704R1	NSP
R8421	CHIP TYPE CARBON RESISTOR	RN72K1J-103JE	1	435031034R1	NSP
R8422	CHIP TYPE CARBON RESISTOR	RN72K1J-101JE	1	435031014R1	NSP
R8423	CHIP TYPE CARBON RESISTOR	RN72K1J-332JE	1	435033324R1	NSP
R8424	CHIP TYPE CARBON RESISTOR	RN72K1J-332JE	1	435033324R1	NSP
R8425	CHIP TYPE CARBON RESISTOR	RN72K1J-470JE	1	435034704R1	NSP
R8426	CHIP TYPE CARBON RESISTOR	RN72K1J-470JE	1	435034704R1	NSP
R8427	CHIP TYPE CARBON RESISTOR	RN72K1J-100JE	1	435031004R1	NSP
R8429	CHIP TYPE CARBON RESISTOR	RN72K1J-470JE	1	435034704R1	NSP
R8430	CHIP TYPE CARBON RESISTOR	RN72K1J-470JE	1	435034704R1	NSP
R8431	CHIP TYPE CARBON RESISTOR	RN72K1J-470JE	1	435034704R1	NSP
R8432	CHIP TYPE CARBON RESISTOR	RN72K1J-470JE	1	435034704R1	NSP
R8437	CHIP TYPE CARBON RESISTOR	RN72K1J-473JE	1	435034734R1	NSP
R8438	CHIP TYPE CARBON RESISTOR	RN72K1J-220JE	1	435032204R1	NSP
R8439	CHIP TYPE CARBON RESISTOR	RN72K1J-220JE	1	435032204R1	NSP
R8440	CHIP TYPE CARBON RESISTOR	RN72K1J-220JE	1	435032204R1	NSP
R8441	CHIP TYPE CARBON RESISTOR	RN72K1J-220JE	1	435032204R1	NSP
R8442	CHIP TYPE CARBON RESISTOR	RN72K1J-220JE	1	435032204R1	NSP
R8443	CHIP TYPE CARBON RESISTOR	RN72K1J-220JE	1	435032204R1	NSP
R8444	CHIP TYPE CARBON RESISTOR	RN72K1J-101JE	1	435031014R1	NSP
R8445	CHIP TYPE CARBON RESISTOR	RN72K1J-101JE	1	435031014R1	NSP
R8446	CHIP TYPE CARBON RESISTOR	RN72K1J-472JE	1	435034724R1	NSP
R8447	CHIP TYPE CARBON RESISTOR	RN72K1J-102JE	1	435031024R1	NSP
R8448	CHIP TYPE CARBON RESISTOR	RN72K1J-103JE	1	435031034R1	NSP

R8449	CHIP TYPE CARBON RESISTOR	RN72K1J-182JE	1	435031824R1	NSP
R8450	CHIP TYPE CARBON RESISTOR	RN72K1J-182JE	1	435031824R1	NSP
R8451	CHIP TYPE CARBON RESISTOR	RN72K1J-000JE	1	435030004R1	NSP
R8452	CHIP TYPE CARBON RESISTOR	RN72K1J-103FE	1	435031032R1	NSP
R8453	CHIP TYPE CARBON RESISTOR	RN72K1J-223FE	1	435032232R1	NSP
R8458	CHIP TYPE CARBON RESISTOR	RN72K1J-100JE	1	435031004R1	NSP
R8459	CHIP TYPE CARBON RESISTOR	RN72K1J-560JE	1	435035604R1	NSP
R8461	CHIP TYPE CARBON RESISTOR	RN72K1J-560JE	1	435035604R1	NSP
R8462	CHIP TYPE CARBON RESISTOR	RN72K1J-473JE	1	435034734R1	NSP
R8463	CHIP TYPE CARBON RESISTOR	RN72K1J-220JE	1	435032204R1	NSP
R8464	CHIP RESISTOR NETWORK	MNR04MRAPJ470	1	43464747004R2	NSP
R8464or	CHIP RESISTOR NETWORK	YCN104-470-JK	(1)	43464C47004R1	NSP
R8466	CHIP RESISTOR NETWORK	MNR04MRAPJ220	1	43464722004R2	NSP
R8466or	CHIP RESISTOR NETWORK	YCN104-220-JK	(1)	43464C22004R1	NSP
R8467	CHIP RESISTOR NETWORK	MNR04MRAPJ220	1	43464722004R2	NSP
R8467or	CHIP RESISTOR NETWORK	YCN104-220-JK	(1)	43464C22004R1	NSP
R8468	CHIP RESISTOR NETWORK	MNR04MRAPJ220	1	43464722004R2	NSP
R8468or	CHIP RESISTOR NETWORK	YCN104-220-JK	(1)	43464C22004R1	NSP
R8469	CHIP RESISTOR NETWORK	MNR04MRAPJ220	1	43464722004R2	NSP
R8469or	CHIP RESISTOR NETWORK	YCN104-220-JK	(1)	43464C22004R1	NSP
R8471	CHIP TYPE CARBON RESISTOR	RN72K1J-220JE	1	435032204R1	NSP
R8472	CHIP TYPE CARBON RESISTOR	RN72K1J-220JE	1	435032204R1	NSP
R8473	CHIP TYPE CARBON RESISTOR	RN72K1J-220JE	1	435032204R1	NSP
R8474	CHIP TYPE CARBON RESISTOR	RN72K1J-220JE	1	435032204R1	NSP
R8475	CHIP TYPE CARBON RESISTOR	RN72K1J-220JE	1	435032204R1	NSP
R8480	CHIP TYPE CERAMIC CAPACITOR	CK725B1H-102K0	1	332031025R1	NSP
R8481	CHIP RESISTOR NETWORK	MNR04MRAPJ220	1	43464722004R2	NSP
R8481or	CHIP RESISTOR NETWORK	YCN104-220-JK	(1)	43464C22004R1	NSP
R8482	CHIP RESISTOR NETWORK	MNR04MRAPJ220	1	43464722004R2	NSP
R8482or	CHIP RESISTOR NETWORK	YCN104-220-JK	(1)	43464C22004R1	NSP
R8483	CHIP TYPE CARBON RESISTOR	RN72K2E-000JE	1	435220004R1	NSP
R8613	CHIP TYPE CARBON RESISTOR	RN72K1J-473JE	1	435034734R1	NSP
R8614	CHIP TYPE CARBON RESISTOR	RN72K1J-473JE	1	435034734R1	NSP
R8615	CHIP TYPE CARBON RESISTOR	RN72K1J-100JE	1	435031004R1	NSP
R8623	CHIP TYPE CARBON RESISTOR	RN72K1J-473JE	1	435034734R1	NSP
R8624	CHIP TYPE CARBON RESISTOR	RN72K1J-473JE	1	435034734R1	NSP
R8625	CHIP TYPE CARBON RESISTOR	RN72K1J-100JE	1	435031004R1	NSP
R8633	CHIP TYPE CARBON RESISTOR	RN72K1J-473JE	1	435034734R1	NSP
R8634	CHIP TYPE CARBON RESISTOR	RN72K1J-473JE	1	435034734R1	NSP
R8635	CHIP TYPE CARBON RESISTOR	RN72K1J-100JE	1	435031004R1	NSP
R8702	CHIP RESISTOR NETWORK	MNR04MRAPJ221	1	43464722104R2	NSP
R8702or	CHIP RESISTOR NETWORK	YCN104-221-JK	(1)	43464C22104R1	NSP
R8703	CHIP TYPE CARBON RESISTOR	RN72K1J-103JE	1	435031034R1	NSP
R8704	CHIP RESISTOR NETWORK	MNR04MRAPJ103	1	43464710304R2	NSP
R8704or	CHIP RESISTOR NETWORK	YCN104-103-JK	(1)	43464C10304R1	NSP
R8705	CHIP TYPE CARBON RESISTOR	RN72K1J-473JE	1	435034734R1	NSP
R8707	CHIP RESISTOR NETWORK	MNR04MRAPJ103	1	43464710304R2	NSP
R8707or	CHIP RESISTOR NETWORK	YCN104-103-JK	(1)	43464C10304R1	NSP
R8709	CHIP TYPE CARBON RESISTOR	RN72K1J-470JE	1	435034704R1	NSP
R8710	CHIP TYPE CARBON RESISTOR	RN72K1J-102JE	1	435031024R1	NSP
R8711	CHIP TYPE CARBON RESISTOR	RN72K1J-103JE	1	435031034R1	NSP
R8712	CHIP TYPE CARBON RESISTOR	RN72K1J-470JE	1	435034704R1	NSP
R8713	CHIP TYPE CARBON RESISTOR	RN72K1J-101JE	1	435031014R1	NSP
R8718	CHIP TYPE CARBON RESISTOR	RN72K1J-222JE	1	435032224R1	NSP
R8719	CHIP TYPE CARBON RESISTOR	RN72K1J-222JE	1	435032224R1	NSP

R8720	CHIP TYPE CARBON RESISTOR	RN72K1J-103JE	1	435031034R1	NSP
R8721	CHIP RESISTOR NETWORK	MNR04MRAPJ470	1	43464747004R2	NSP
R8721or	CHIP RESISTOR NETWORK	YCN104-470-JK	(1)	43464C47004R1	NSP
R8723	CHIP TYPE CARBON RESISTOR	RN72K1J-472JE	1	435034724R1	NSP
R8727	CHIP TYPE CARBON RESISTOR	RN72K1J-221JE	1	435032214R1	NSP
R8728	CHIP TYPE CARBON RESISTOR	RN72K1J-103JE	1	435031034R1	NSP
R8729	CHIP TYPE CARBON RESISTOR	RN72K1J-221JE	1	435032214R1	NSP
R8730	CHIP TYPE CARBON RESISTOR	RN72K1J-470JE	1	435034704R1	NSP
R8731	CHIP RESISTOR NETWORK	MNR04MRAPJ103	1	43464710304R2	NSP
R8731or	CHIP RESISTOR NETWORK	YCN104-103-JK	(1)	43464C10304R1	NSP
R8732	CHIP TYPE CARBON RESISTOR	RN72K1J-221JE	1	435032214R1	NSP
R8733	CHIP TYPE CARBON RESISTOR	RN72K1J-105JE	1	435031054R1	NSP
R8734	CHIP TYPE CARBON RESISTOR	RN72K1J-470JE	1	435034704R1	NSP
R8736	CHIP TYPE CARBON RESISTOR	RN72K1J-102JE	1	435031024R1	NSP
R8737	CHIP TYPE CARBON RESISTOR	RN72K1J-472JE	1	435034724R1	NSP
R8738	CHIP TYPE CARBON RESISTOR	RN72K1J-103JE	1	435031034R1	NSP
R8739	CHIP TYPE CARBON RESISTOR	RN72K1J-102JE	1	435031024R1	NSP
R8740	CHIP TYPE CARBON RESISTOR	RN72K1J-103JE	1	435031034R1	NSP
R8741	CHIP TYPE CARBON RESISTOR	RN72K1J-102JE	1	435031024R1	NSP
R8743	CHIP TYPE CARBON RESISTOR	RN72K1J-103JE	1	435031034R1	NSP
R8745	CHIP TYPE CARBON RESISTOR	RN72K1J-103JE	1	435031034R1	NSP
R8746	CHIP TYPE CARBON RESISTOR	RN72K1J-470JE	1	435034704R1	NSP
R8750	CHIP TYPE CARBON RESISTOR	RN72K1J-470JE	1	435034704R1	NSP
R8752	CHIP RESISTOR NETWORK	MNR04MRAPJ470	1	43464747004R2	NSP
R8752or	CHIP RESISTOR NETWORK	YCN104-470-JK	(1)	43464C47004R1	NSP
R8753	CHIP RESISTOR NETWORK	MNR04MRAPJ470	1	43464747004R2	NSP
R8753or	CHIP RESISTOR NETWORK	YCN104-470-JK	(1)	43464C47004R1	NSP
R8756	CHIP TYPE CARBON RESISTOR	RN72K1J-470JE	1	435034704R1	NSP
R8757	CHIP RESISTOR NETWORK	MNR04MRAPJ101	1	43464710104R2	NSP
R8757or	CHIP RESISTOR NETWORK	YCN104-101-JK	(1)	43464C10104R1	NSP
R8758	CHIP TYPE CARBON RESISTOR	RN72K1J-103JE	1	435031034R1	NSP
R8900	CHIP TYPE CARBON RESISTOR	RN72K1J-472JE	1	435034724R1	NSP
R8904	CHIP TYPE CARBON RESISTOR	RN72K1J-102JE	1	435031024R1	NSP
R8922	CHIP TYPE CARBON RESISTOR	RN72K1J-473JE	1	435034734R1	NSP
R8923	CHIP TYPE CARBON RESISTOR	RN72K1J-332JE	1	435033324R1	NSP
R8924	CHIP TYPE CARBON RESISTOR	RN72K1J-682FE	1	435036822R1	NSP
R8925	CHIP TYPE CARBON RESISTOR	RN72K1J-332FE	1	435033322R1	NSP
R8926	CHIP TYPE CARBON RESISTOR	RN72K1J-103FE	1	435031032R1	NSP
R8932	CHIP TYPE CARBON RESISTOR	RN72K1J-473JE	1	435034734R1	NSP
R8933	CHIP TYPE CARBON RESISTOR	RN72K1J-332JE	1	435033324R1	NSP
R8934	CHIP TYPE CARBON RESISTOR	RN72K1J-272FE	1	435032722R1	NSP
R8935	CHIP TYPE CARBON RESISTOR	RN72K1J-222FE	1	435032222R1	NSP
R8936	CHIP TYPE CARBON RESISTOR	RN72K1J-103FE	1	435031032R1	NSP
R8939	CHIP TYPE CARBON RESISTOR	RN72K1J-102JE	1	435031024R1	NSP
R8952	CHIP TYPE CARBON RESISTOR	RN72K1J-473JE	1	435034734R1	NSP
R8953	CHIP TYPE CARBON RESISTOR	RN72K1J-682JE	1	435036824R1	NSP
R8954	CHIP TYPE CARBON RESISTOR	RN72K1J-333FE	1	435033332R1	NSP
R8955	CHIP TYPE CARBON RESISTOR	RN72K1J-124FE	1	435031242R1	NSP
R8956	CHIP TYPE CARBON RESISTOR	RN72K1J-103FE	1	435031032R1	NSP
R8958	CHIP TYPE CARBON RESISTOR	RN72K1J-473JE	1	435034734R1	NSP
R8962	CHIP TYPE CARBON RESISTOR	RN72K1J-473JE	1	435034734R1	NSP
R8964	CHIP TYPE CARBON RESISTOR	RN72K1J-563FE	1	435035632R1	NSP
R8965	CHIP TYPE CARBON RESISTOR	RN72K1J-274JE	1	435032744R1	NSP
R8966	CHIP TYPE CARBON RESISTOR	RN72K1J-103FE	1	435031032R1	NSP
R8982	CHIP TYPE CARBON RESISTOR	RN72K1J-104JE	1	435031044R1	NSP

R8983	CHIP TYPE CARBON RESISTOR	RN72K1J-473JE	1	435034734R1	NSP
R8984	CHIP TYPE CARBON RESISTOR	RN72K1J-103JE	1	435031034R1	NSP
R8985	CHIP TYPE CARBON RESISTOR	RN72K1J-473JE	1	435034734R1	NSP
R8987	CHIP TYPE CARBON RESISTOR	RN72K1J-000JE	1	435030004R1	NSP
R8989	CHIP TYPE CARBON RESISTOR	RN72K1J-103JE	1	435031034R1	NSP
<b>[ Switches, Terminals, Wires ]</b>					
P030	PRINTED WIRING BOARD	BCPRC-2387	1	25142387	<b>N</b> NSP
P2001B	PLUG	NPLG-7P920	1	25055967R2	NSP
P2500A	SOCKET	IMSA-9618S-09A	1	25053334R2	NSP
P3601	SOCKET	UB113-F04S1BR-B	1	25053652R2	NSP
P3602	PLUG	JM-72PIN-V(3MM)	1	25056785R2	NSP
P3603	PLUG	JM-32PIN-V(3MM)	1	25056784R2	NSP
P3651	SOCKET	MP04B1S2AM0-07T	1	25053617R3	NSP
P3652C	PLUG	NPLG-5P918	1	25055965R2	NSP
P6800B	PLUG	NPLG-5P918	1	25055965R2	NSP
P7000	SOCKET	IMSA-9618S-15A	1	25053340R2	NSP
P7001A	SOCKET	31FMN-SMT-A-TF	1	25052848R2	NSP
P7002A	SOCKET	IMSA-9618S-15A	1	25053340R2	NSP
P7501	SOCKET	NSCT-9P2472	1	25052575R2	NSP
P8001	SOCKET	51U019S-3HFDN-BD-SM	1	25053549R3	NSP
P8001or	SOCKET	TCX3423-311387	(1)	25060513R3	NSP
P8001or	SOCKET	HDMI(47266-4101)	(1)	25053389R3	NSP
P8002A	PLUG	IMSA-9850B-30Y	1	25056329R2	NSP
P8611	SOCKET	51U019S-3HFDN-BD-SM	1	25053549R3	NSP
P8611or	SOCKET	TCX3423-311387	(1)	25060513R3	NSP
P8611or	SOCKET	HDMI(47266-4101)	(1)	25053389R3	NSP
P8621	SOCKET	51U019S-3HFDN-BD-SM	1	25053549R3	NSP
P8621or	SOCKET	TCX3423-311387	(1)	25060513R3	NSP
P8621or	SOCKET	HDMI(47266-4101)	(1)	25053389R3	NSP
P8631	SOCKET	51U019S-3HFDN-BD-SM	1	25053549R3	NSP
P8631or	SOCKET	TCX3423-311387	(1)	25060513R3	NSP
P8631or	SOCKET	HDMI(47266-4101)	(1)	25053389R3	NSP
P8641	SOCKET	51U019S-3HFDN-BD-SM	1	25053549R3	NSP
P8641or	SOCKET	TCX3423-311387	(1)	25060513R3	NSP
P8641or	SOCKET	HDMI(47266-4101)	(1)	25053389R3	NSP